

the cell to green light blue-shifted the LH reflection back to where it overlapped the RH reflection.

The researchers said, “Inducing hyper-reflectivity was the first step; now we are working toward making the polymer

scaffold dynamic to enable fully tunable hyper-reflectivity.”

**Steven Trohalaki**

**Nano Focus**

**High-yield, low-cost approach developed to functionalize MWCNT surface**

**M**ultiwalled carbon nanotubes (MWCNTs) are finding increasing use in a variety of applications such as scanning probe microscope tips, hydrogen storage devices, catalyst support, and energy storage devices. Carbon nanotubes (CNTs) are often modified to prepare templates for advanced sensing technologies. A number of studies have reported attempts to functionalize the surface of CNTs for improved templating. A recent study by researchers from Virginia Tech has yielded CNTs functionalized with a uniform layer of metal oxide on the nanotube surface that afford high yield with low costs.

Previous studies have mostly resulted in CNTs functionalized with metal nanoparticles. There has been limited success

with coating CNTs with oxides. In the November 2010 issue of the *Journal of the American Ceramic Society* (DOI: 10.1111/j.1551-2916.2010.04154.x; p. 3618), V. Bedekar, S. Priya, and their colleagues from Virginia Tech introduce a technique to prepare MWCNTs uniformly coated with BaTiO<sub>3</sub>.

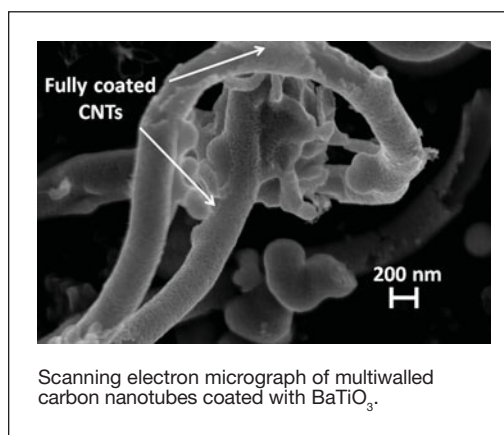

Scanning electron micrograph of multiwalled carbon nanotubes coated with BaTiO<sub>3</sub>.

In this two-step process, CNTs were first immersed in nitric acid to incorporate surface –OH functional groups that act as sites for BaTiO<sub>3</sub> attachment. The acid-functionalized CNTs were immersed in a solution of barium titanium ethylhexanoisopropoxide and isopropanol. Transmission electron micrographs revealed that the MWCNTs were uniformly coated by BaTiO<sub>3</sub> with thickness in the range of 5–20 nm. Changes in chemical composition resulting from surface functionalization were characterized using a combination of infrared and x-ray energy-dispersive spectroscopy.

The research team said that these surface-functionalized CNTs will find use in diodes, sensors, and smart textiles.

**Kaushik Chatterjee**

**Nano Focus**

**High-fidelity transfer of intricate photonic devices via nanomembranes demonstrated**

**S**ilicon nanomembranes (Si-NM) are typically fabricated by harvesting the top Si layer of the silicon-on-insulator (SOI) wafers. Selective etching of the middle buried oxide layer releases the top Si device layer from the bulk as a nanomembrane. The fragile nanomembrane is susceptible to cracks and wrinkles during transfer to other substrates often resulting in a partial transfer. Furthermore, the scalability of the transfer process is limited. Now M.J. Zablocki and D.W. Prather from the University of Delaware and A. Sharkawy and O. Ebil from EM Photonics, Newark have overcome these challenges by developing a high-fidelity direct transfer process that can be used

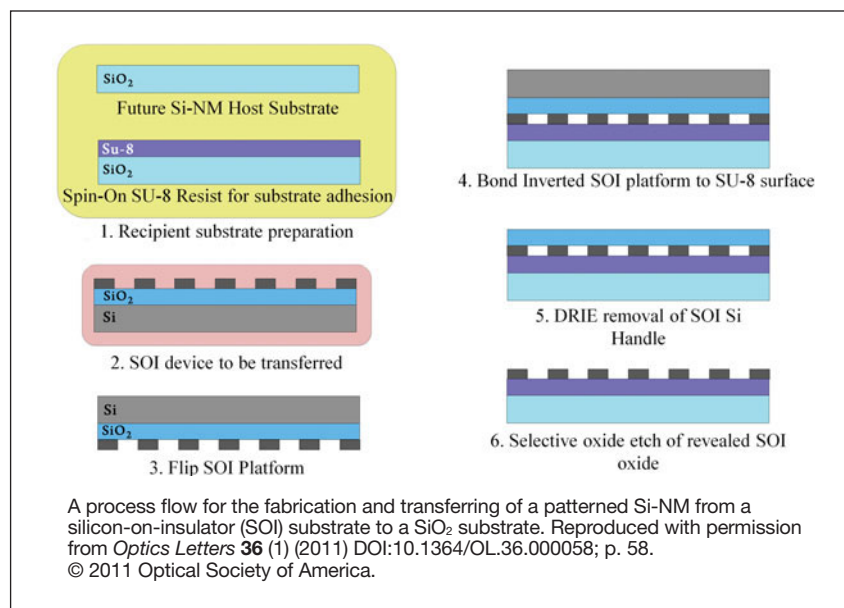

to transfer electronic and photonic devices without compromising structural integrity and functionality.

The researchers describe their fabrication protocols in the January 1st issue of *Optics Letters* (DOI:10.1364/



OL.36.000058; p. 58). The researchers started with a SOI substrate as a source of the Si-NMs. The recipient silicon dioxide substrate is spin-cast with SU-8 polymer (see Figure). The preprocessed SOI host substrate containing the transferable devices is inverted and contacted with the polymer-cast recipient substrate. Heating the substrates to over 60°C allows the polymer to reflow and any trapped air bubbles are allowed to escape resulting in a uniform transfer. Furthermore, the reflow step allows any fine-tuning of

the alignment of the host and recipient substrates. The host and the recipient substrate which are in contact at this point are subjected to a deep reactive ion etch to selectively remove the silicon handle from the host substrate. A buffered oxide wet etch selectively removes the oxide layer from the SOI host leaving the transferred Si-NM on the recipient substrate with the underlying polymer layer. The direct transfer process can be repeated to sequentially stack multiple Si-NMs.

In order to demonstrate the feasibility

of transferring a photonic device that retained its functionality, the researchers utilized a photonic crystal directional coupler. Following the transfer, spectral scans between 1550 nm and 1558 nm revealed directional coupling between waveguides at the two wavelengths in the transferred device. The researchers said that to the best of their knowledge “this is the only nanomembrane photonic device which uses the confinement properties of the transferred Si-NM.”

**Soma Chattopadhyay**

### Nano Focus

**Nanoscale study helps explain materials' ability to convert waste heat to electricity**

An international team of researchers has discovered that a class of materials known to convert heat to electricity and vice versa behaves unexpectedly at the nanoscale in response to changes in temperature. The discovery—described in the December 17, 2010, issue of *Science* (DOI: 10.1126/science.1192759; p. 1660)—is an “opposite-direction” phase transition that helps explain the strong thermoelectric response of these materials. It may also help scientists identify other useful thermoelectrics, and could further their application in capturing energy lost as heat, for example, in automotive and factory exhaust.

The scientists—from Brookhaven National Laboratory, Columbia University, Argonne National Laboratory, Los Alamos National Laboratory, Northwestern University, and the Swiss Federal Institute of Technology—were studying lead chalcogenides (lead paired with tellurium, selenium, or sulfur) using newly available experimental techniques and theoretical approaches that allow them to “see” and model behavior of individual atoms at the nanoscale. With those tools they were able to observe subtle changes in atomic arrangements invisible to conventional probes of structure.

Simon Billinge, a physicist at Brookhaven Lab and Columbia University’s School of Engineering and Applied Science and a lead author on the *Science* paper, said that the development of localized atomic distortions upon cooling is normal. He said, “What we discovered in lead chalcogenides is the opposite behavior: At the very lowest temperature, there were no atomic displacements, nothing—but on warming, displacements appear!”

The lead materials were made in a purified powder form. The researchers then bombarded the samples with neutrons using the Lujan Neutron Scattering Center at Los Alamos as a source. Detectors gather information about how these beams scatter off the sample to produce diffraction patterns that indicate positions and arrangements of the atoms. Further mathematical and computational analysis of the data allowed the scientists to model and interpret what was happening at the atomic level over a range of temperatures.

Brookhaven physicist Emil S. Božin, first author on the article, was the first to notice the odd behavior in the data. “If we had just looked at the average structure, we never would have observed this effect. Our analysis of atomic pair distribution functions gives us a much more local view—the distance from one particular atom to its nearest neighbors—rather than just the average,” Božin said. The detailed analysis revealed that, as the material got warmer, these distances

were changing on a tiny scale—about 0.025 nm—demonstrating that individual atoms were becoming displaced.

The displacements can be pictured as tiny arrows with the points indicating the orientations of the atoms. Upon heating, these dipoles appear and flip back and forth, or fluctuate.

According to the scientists, it is this random flipping behavior that is key to the materials’ ability to convert heat into electricity.

Billinge said, “This low thermal conductivity allows a large temperature gradient to be maintained across the sample, which is crucial to the thermoelectric properties.”

When one side of the material comes in contact with heat—for example, in the exhaust system of a car—the gradient will cause charge carriers in the thermoelectric material (e.g., electrons) to diffuse from the hot side to the cold side. Capturing this thermally induced electric current could put the “waste” heat to use.

According to the research team, this work may help scientists search for other thermoelectric materials with exceptional properties, since it links the good thermoelectric response to the existence of fluctuating dipoles.

Other members of the research team are C.D. Malliakas, P. Souvatzis, T. Proffen, N.A. Spaldin, and M.G. Kanatzidis. □