

## RESEARCH RESOURCES

A summary of new products and services for materials research...

**Magnetic Field-Independent Temperature Sensors:** New series of multilayer ceramic capacitance sensors offers stable, monotonic response with a range from 1.5 to 290 K when used as a control sensor in magnetic fields of 19 tesla or more. Magnetic field dependence:  $dT/T = 0.15\%$  at 4.2 K and 18.7 tesla,  $dT/T = 0.05\%$  at 77 K, 305 K, and 18.7 tesla. The CS-501 sensor provides stable temperature over long periods of application. As a magnetic field is applied, the temperature sensor can be used to maintain a fixed temperature or monitor any variations which occur. Lake Shore Cryotronics, 64 East Walnut Street, Westerville, OH 43081; (614) 891-2243.

**Eight-Inch Diameter Sputtering Target:** Unprecedented target size allows companies to use existing production equipment for commercial superconductivity applications with no additional capital investment. This target, the source material for superconductive thin films, weighs over 1,300 gm and is made from the purest commercially available superconductive powder. Price: \$2,880. Special consideration for educational institutions and dealers or manufacturers of sputtering equipment. Superconductive Components, Inc., 1145 Chesapeake Ave., Columbus, OH 43212; (614) 486-0261.

**Glow Discharge Quadrupole Mass Spectrometer:** Designed for quick, easy, cost-effective sample preparation, this mass spectrometer provides high sensitivity for low-level detection limits. A solid sample is inserted in the mass spectrometer source, which uses a glow discharge plasma to make ions. Differentially pumped system is equipped with a 19 mm quadrupole mass filter with mass range from 1-300 amu, and features an energy analyzer and PC data acquisition system. Extrel Corporation, 240 Alpha Dr., Box 11512, Pittsburgh, PA 15238; (412) 963-7530.

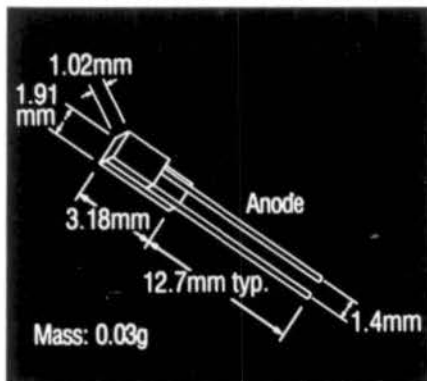

DT-471

Leads: Gold-plated Kovar, uninsulated.  
0.38mm × 0.10mm cross-section  
× approx. 12.7mm long.

### Magnetic Field-Independent Temperature Sensors

**Processing Techniques for High T<sub>c</sub> Superconductors:** Detailed compilation of all the approaches attempted to date for processing high temperature superconductors was recently published in a special issue of *Materials and Processing Report*. More than 100 listings are divided into five tables: physical vapor deposition, chemical vapor deposition, and solution techniques for processing thin films; thick film processes; and bulk processes. The tables contain the most complete and up-to-date information available on the processing of the 1-2-3 rare-earth, bismuth, and thallium compounds, including the key details of the processing conditions, T<sub>c</sub> and J<sub>c</sub>, and the information source. The tables will be updated regularly. This special issue is available free with a subscription to *Materials and Processing Report*. Beth Barovick, MIT Press Journals, 55 Hayward Street, Cambridge, MA 02142; (617) 253-2864.

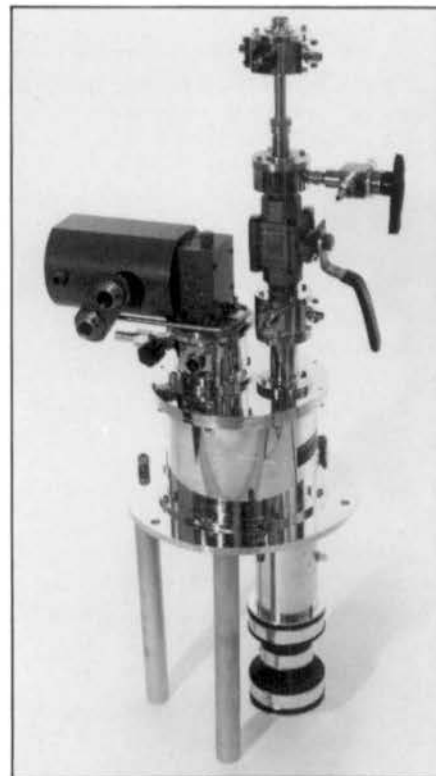

Materials Analysis Cryostat

**Materials Analysis Cryostat:** Specifically designed for high T<sub>c</sub> superconductive materials, the LTS-22-MAC closed-cycle materials analysis cryostat boasts a sample access, exchange gas environment, customized sample probes, and precision temperature controllers. A complete Meissner coil kit is available consisting of a room temperature primary and sample temperature, back to back, secondary coils and bench stands. A new sample probe can operate up to 600 K. RMC-Cryosystems, Inc., 1802 W. Grant Rd., Tucson, AZ 85745; (602) 882-4228.

**Spectroscopic Ellipsometer:** Optical and electronic components are combined with Type 436 or 437 folding optical benches to permit automatic measurement of  $\Delta$  and  $\Psi$  as a function of wavelength using Fourier analysis of the photodetected signal. A Hewlett Packard computer controls the ellipsometer and wavelength scanning double monochromator, sets measurement protocols, performs data reduction, and presents results to the operator. The software package contains modeling routines for determining the composition of nonhomogenous substrates and films using Bruggeman and Maxwell-Garnett effective medium approximations. Rudolph Research, P.O. Box 1000, Flanders, NJ 07836; (201) 691-1300.

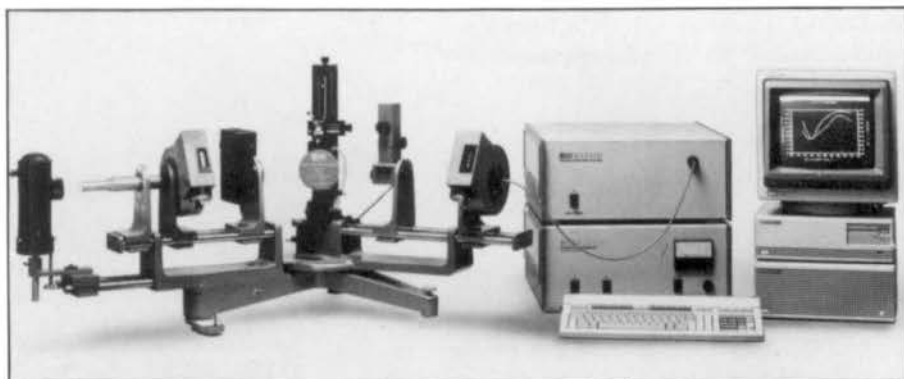

Spectroscopic Ellipsometer

## RESEARCH RESOURCES

**Applying Supercomputing to Materials Science:** Report by a committee of the U.S. National Materials Advisory Board assesses opportunities for computer simulation and analysis of materials structure, properties and processing using both atomistic and continuum methods. Publication NMAB-451, "The Impact of Supercomputing Capabilities on U.S. Materials Science and Technology," is available for \$15. National Materials Advisory Board, National Research Council, 2101 Constitution Avenue, Washington, DC 20418; (202) 334-3505.

**Directory of Testing Laboratories:** Directory lists 1,100 laboratories, contacts, and detailed indexes. Specifically written for the purchaser of laboratory services, the guide lists contact name, phone number, address, specialty, fields of testing covered, materials and products analyzed, equipment, staff, and branch locations. List price: \$50.00. ASTM, 1916 Race St., Philadelphia, PA 19103; (215) 299-5400.

**Research Centers Directory:** Two-volume reference to 10,302 nonprofit and university-related research units in the U.S. and Canada covers 17 subject fields grouped into five broad categories: Life Sciences, Physical Sciences and Engineering, Private and Public Policy and Affairs, Social and Cultural Studies, and Multidisciplinary and Coordinating Centers. The standard entry furnishes up to 22 pieces of information about the research unit—research center name, address and telephone number, year founded, organization head, sources of support, volume of research, staff, research contact, affiliated centers, fields of research, special resources, publications and services, and more. In addition to a master name, keyword and acronym index, the guide also contains a subject index, an institutional index, and a special capabilities index. Price: \$245. Gale Research Inc., Book Tower, Detroit, MI 48226-9948; (800) 223-4253 or (313) 961-2242.

**Optics Education Programs:** Yearly directory of optics education programs in North America is available free of charge. Published with the assistance of Lawrence Livermore National Laboratory, the 1989 directory is designed as a tool for students seeking education opportunities and as a resource for employers. Information about grants and scholarships available through SPIE is also included. SPIE, P.O. Box 10, Bellingham, WA 98227-0010; (206) 676-3290.

**DOE Report to Congress:** Department of Energy report covers fiscal year 1987 and provides information on the programs and activities of all elements of the department, except the independent Federal Energy Regulatory Commission. The 400-page report, GPO stock number 061-000-00715-6, is available for \$29. Superintendent of Documents, U.S. Government Printing Office, Washington, D.C. 20402. □

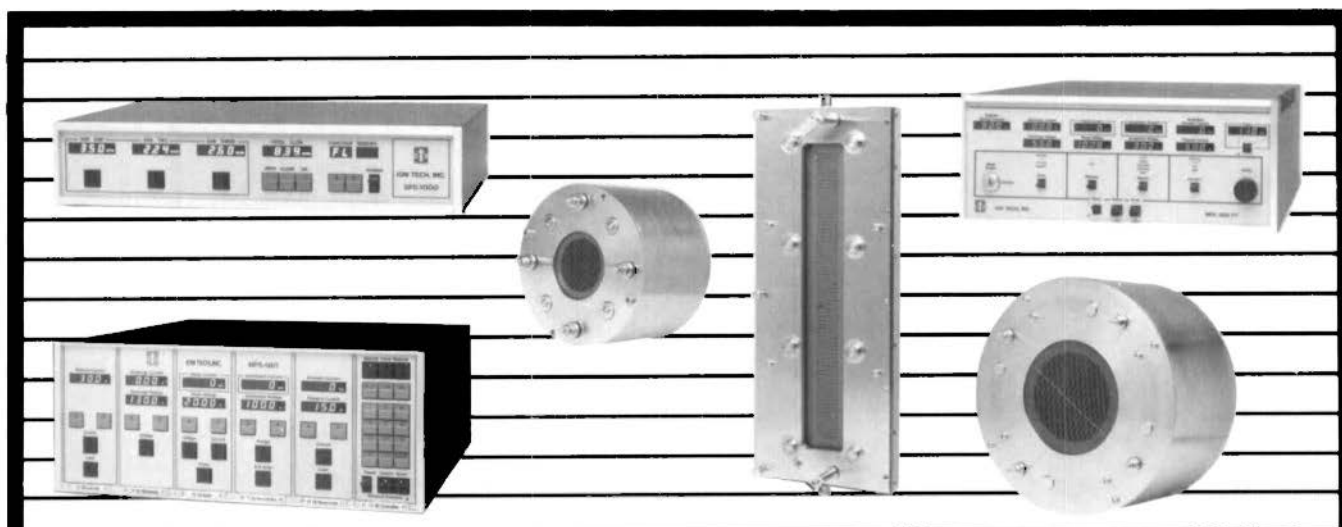

# Ion Tech: Your One Source

- Complete line of round and linear broad beam ion sources
- Microprocessor-based power supplies with RS-232 port for remote control, datalogging and errorlogging
- Sources operate with beam energies ranging from 50-2000eV
- Sources are UHV compatible, run on inert or reactive gas and retrofit easily by mounting internally or on a chamber flange
- GFC-1000 Gas Flow Control System provides integrated gas flow control with source control for optimum operation

Please visit Booth No. 102 at the MRS Show in San Diego, April 25-27



**ION TECH, INC.**

2330 East Prospect  
Fort Collins, CO 80525  
Telephone 303.221.1807  
Facsimile 303.493.1439