



# Fully heavy tetraquark $bb\bar{c}\bar{c}$ : lifetimes and weak decays

Gang Li<sup>1,a</sup>, Xiao-Feng Wang<sup>1</sup>, Ye Xing<sup>2,b</sup>

<sup>1</sup> School of Physics and Engineering, Qufu Normal University, Qufu 273165, China

<sup>2</sup> INPAC, SKLPPC, MOE Key Laboratory for Particle Physics, School of Physics and Astronomy, Shanghai Jiao Tong University, Shanghai 200240, China

Received: 30 April 2019 / Accepted: 18 July 2019 / Published online: 7 August 2019  
© The Author(s) 2019

**Abstract** We study the lifetime and weak decays of the full-heavy S-wave  $0^+$  tetraquark  $T_{\{\bar{c}\bar{c}\}}^{\{bb\}}$ . Using the operator product expansion rooted in heavy quark expansion, we find a rather short lifetime, at the order  $(0.1 - 0.3) \times 10^{-12}s$  depending on the inputs. With the flavor SU(3) symmetry, we then construct the effective Hamiltonian at the hadron level, and derive relations between decay widths of different channels. According to the electro-weak effective operators, we classify different decay modes, and make a collection of the golden channels, such as  $T_{\{\bar{c}\bar{c}\}}^{\{bb\}} \rightarrow B^- K^0 B_c^-$  for the charm quark decay and  $T_{\{\bar{c}\bar{c}\}}^{\{bb\}} \rightarrow B^- D^-$  for the bottom quark decay. Our results for the lifetime and golden channels are helpful to search for the fully-heavy tetraquark in future experiments.

## 1 Introduction

In the past decades, quark model has achieved great successes in the hadron spectroscopy study. In addition to the quark-anti-quark assignment for a meson and three-quark interpretation of a baryon, it allows the existence of non-standard exotic states [1–6]. Since the observation of  $X(3872)$  in 2003 [1], many exotic candidates have been announced on the experimental side in the heavy quarkonium sector in various processes [7]. Charged heavy quarkoniumlike states  $Z_c(3900)^\pm$ ,  $Z_c(4020)^\pm$ ,  $Z_b(10610)^\pm$ , and  $Z_b(10650)^\pm$  observed by BES-III and Belle collaborations [2–4] have already experimentally established as being exotic, since they contain at least two quarks and two anti-quarks with the hidden  $Q\bar{Q}$ . Until now, extensive theoretical studies have been carried out to explore their internal structures, production and decay behaviors [8–37]. Most of the established states tend to contain a pair of heavy quark, and thus the discovery of exotic states of new categories will be

valuable. Fully-heavy four-quark state with no light quark degrees of freedom is of this type and might be an ideal probe to study the interplay between perturbative QCD and non-perturbative QCD.

Generally speaking, more heavy quarks correspond to a larger mass. For instance, there have been some phenomenological studies to determine the mass and the spectrum properties of the fully-heavy tetraquark  $b\bar{c}b\bar{c}$ , including the constituent quark and diquark model [38,39], simple quark model [40], nonrelativistic effective field theory(NREFT) [41], QCD sum rules [42,43], and quark potential model [44]. In Ref. [41], the authors utilize the NREFT to determine the mass with the upper bound as 12.58 GeV, consistent with the mass calculated in the simple quark model [40]. Despite of these studies, it is still not conclusive that whether the  $b\bar{c}b\bar{c}$  (or its charge conjugate  $\bar{c}b\bar{c}b$ ) is above or below the  $B_c B_c$  threshold. It is likely that the  $b\bar{c}b\bar{c}$  lies below the threshold of the  $B_c B_c$  pair, which means that such a state is stable against the strong interaction. In this case, the dominant decay modes would be induced by weak interaction. In a diquark-diquark model [45], the S-wave fully-heavy tetraquark state  $b\bar{c}b\bar{c}$  can form  $0^+$  and  $2^+$ . In this paper we will mainly focus on the lowest lying state  $0^+$ , which might be assigned as a weakly-coupled state.

In this paper, we will first use the operator product expansion (OPE) technique and calculate the lifetime of the S-wave  $0^+$   $b\bar{c}b\bar{c}$ . The light flavor SU(3) symmetry is a useful tools to analyze weak decays of a heavy quark, and has been successfully applied to the meson or baryon system [46–61]. Though the SU(3) breaking effects in charm quark transition might be sizable, the results from the flavor symmetry can describe the experimental data in a global viewpoint. To be more explicit, one can write down the Hamiltonian at the hadron level with hadron fields and transition operators. Some limited amount of input parameters will be introduced to describe the non-perturbative transitions. With the SU(3) amplitudes, one can obtain relations between decay widths of different processes,

<sup>a</sup> e-mail: [gli@qfnu.edu.cn](mailto:gli@qfnu.edu.cn)

<sup>b</sup> e-mail: [xingye\\_guang@sjtu.edu.cn](mailto:xingye_guang@sjtu.edu.cn)

which can be examined in experiment. Such an analysis is also helpful to identify the decay modes that will be mostly useful to discover the fully-heavy tetraquark state. Since the SU(3) analysis is based on the light quark flavor symmetry, thus the analytical results can work well in all states with the same  $b\bar{c}b\bar{c}$  flavor constituents but with different quantum numbers, even for those molecular states  $B_c B_c$ s. Generally, the molecular states may decay against the strong interaction than the weak interaction.

The rest of this paper is organized as follows. In Sect. 2, we give the particle multiplets under the SU(3) symmetry. Section 3 is devoted to calculate the lifetime of the tetraquark state using the OPE. In Sect. 4, we discuss the weak decays of many-body final states, including mesonic two-body or three-body decays and baryonic two-body decays. In Sect. 5, we present a collection of the golden channels. Finally, we provide a short summary.

### 2 Particle multiplets in SU(3)

The tetraquark with the quark constituents  $b\bar{c}b\bar{c}$  does not contain any light quark and thus is an SU(3) singlet. Recalling that diquark  $[QQ]$  or  $[qq]$  live in  $\mathbf{A}_{\text{color}} \otimes \mathbf{S}_{\text{flavor}} \otimes \mathbf{S}_{\text{spin}}$  spaces, with  $A$  and  $S$  representing the symmetry and anti-symmetry representation respectively, we find the allowed spin quantum numbers are  $\mathbf{1} \otimes \mathbf{1} = \mathbf{0} \oplus \mathbf{2}$ . In this paper, we will mainly focus on the lowest lying state with  $J^P = 0^+$ , which is abbreviated as  $T_{\{\bar{c}\bar{c}\}}^{\{bb\}}$ .

In the baryon sector, we give the SU(3) representations for baryons with different charm quantum numbers ( $C$ ) or bottom quantum numbers ( $B$ ) as follows. The triply heavy baryon with  $C = -3$  denoted as  $\bar{F}_{ccc}$  can form an SU(3) singlet  $\bar{\Omega}_{ccc}^-$ . Baryons with doubly heavy quarks (i.e.  $C = -2, B, C = 1, B = 2$ ) are supposed to be an anti-triplet(triplet) given as

$$(\bar{F}_{cc}^T)_i = \begin{pmatrix} \bar{\Xi}_{cc}^- (\bar{c}\bar{c}\bar{u}) \\ \bar{\Xi}_{cc}^- (\bar{c}\bar{c}\bar{d}) \\ \bar{\Omega}_{cc}^- (\bar{c}\bar{c}\bar{s}) \end{pmatrix}, F_{bc}^i = \begin{pmatrix} \Xi_{bc}^+ (bcu) \\ \Xi_{bc}^0 (bcd) \\ \Omega_{bc}^0 (bcs) \end{pmatrix},$$

$$F_{bb}^i = \begin{pmatrix} \Xi_{bb}^0 (bbu) \\ \Xi_{bb}^- (bbd) \\ \Omega_{bb}^- (bbs) \end{pmatrix}. \tag{1}$$

Consistently, the singly heavy baryons with  $C = -1$  ( $B = 1$ ) are expected to form a triplet(anti-triplet) and a anti-sextet(sextet) as [62]

$$(\bar{F}_{c3})_{[ij]} = \begin{pmatrix} 0 & \bar{\Lambda}_c^- & \bar{\Xi}_c^- \\ -\bar{\Lambda}_c^- & 0 & \bar{\Xi}_c^0 \\ -\bar{\Xi}_c^- & -\bar{\Xi}_c^0 & 0 \end{pmatrix},$$

$$(\bar{F}_{c\bar{6}})_{\{ij\}} = \begin{pmatrix} \bar{\Sigma}_c^- & \frac{1}{\sqrt{2}}\bar{\Sigma}_c^- & \frac{1}{\sqrt{2}}\bar{\Xi}_c^- \\ \frac{1}{\sqrt{2}}\bar{\Sigma}_c^- & \bar{\Sigma}_c^0 & \frac{1}{\sqrt{2}}\bar{\Xi}_c^0 \\ \frac{1}{\sqrt{2}}\bar{\Xi}_c^- & \frac{1}{\sqrt{2}}\bar{\Xi}_c^0 & \bar{\Omega}_c^0 \end{pmatrix}$$

$$(F_{b\bar{3}})^{[ij]} = \begin{pmatrix} 0 & \Lambda_b^0 & \Xi_b^0 \\ -\Lambda_b^0 & 0 & \Xi_b^- \\ -\Xi_b^0 & -\Xi_b^- & 0 \end{pmatrix},$$

$$(F_{b6})^{(ij)} = \begin{pmatrix} \Sigma_b^+ & \frac{1}{\sqrt{2}}\Sigma_b^0 & \frac{1}{\sqrt{2}}\Xi_b^{\prime 0} \\ \frac{1}{\sqrt{2}}\Sigma_b^0 & \Sigma_b^- & \frac{1}{\sqrt{2}}\Xi_b^{\prime -} \\ \frac{1}{\sqrt{2}}\Xi_b^{\prime 0} & \frac{1}{\sqrt{2}}\Xi_b^{\prime -} & \Omega_b^- \end{pmatrix}. \tag{2}$$

In the meson sector, singly heavy mesons form an SU(3) triplet or anti-triplet, while the light mesons form an octet plus a flavor singlet. These multiplets can be written as

$$M_8 = \begin{pmatrix} \frac{\pi^0}{\sqrt{2}} + \frac{\eta}{\sqrt{6}} & \pi^+ & K^+ \\ \pi^- & -\frac{\pi^0}{\sqrt{2}} + \frac{\eta}{\sqrt{6}} & K^0 \\ K^- & \bar{K}^0 & -2\frac{\eta}{\sqrt{6}} \end{pmatrix}, B_i^T = \begin{pmatrix} B^- \\ \bar{B}^0 \\ \bar{B}_s^0 \end{pmatrix},$$

$$D_i^T = \begin{pmatrix} D^0 \\ D^+ \\ D_s^+ \end{pmatrix}, \bar{D}^i = \begin{pmatrix} \bar{D}^0 \\ D^- \\ D_s^- \end{pmatrix}. \tag{3}$$

The weight diagrams of the multiplets are given in Figs. 1 and 2.

### 3 Lifetime

In this section we will discuss the lifetime of  $T_{\{\bar{c}\bar{c}\}}^{\{bb\}}$  using the OPE [63,64]. The decay width of  $T_{\{\bar{c}\bar{c}\}}^{\{bb\}} \rightarrow X$  are as follows:

$$\Gamma(T_{\{\bar{c}\bar{c}\}}^{\{bb\}} \rightarrow X) = \frac{1}{2m_T} \sum_X \int \prod_i \left[ \frac{d^3 \vec{p}_i}{(2\pi)^3 2E_i} \right] (2\pi)^4 \delta^4$$

$$(p_T - \sum_i p_i) \sum_\lambda |\langle X | \mathcal{H} | T_{\{\bar{c}\bar{c}\}}^{\{bb\}} \rangle|^2, \tag{4}$$

where  $m_T$ ,  $p_T^\mu$ , and  $\lambda$  are the mass, four-momentum and spin of  $T_{\{\bar{c}\bar{c}\}}^{\{bb\}}$ , respectively. The electro-weak effective Hamiltonian  $\mathcal{H}_{eff}^{ew}$  is given as

$$\mathcal{H}_{eff}^{ew} = \frac{G_F}{\sqrt{2}} \left[ \sum_{q=u,c} V_c^q (C_1 O_1^q + C_2 O_2^q) - V_p \sum_{j=3} C_j O_j \right] \tag{5}$$

here,  $C_i$  and  $O_i$  are Wilson coefficients and operators.  $V$ s are the combinations of Cabibbo–Kobayashi–Maskawa(CKM) elements. Using the optical theorem, the total decay width of  $\Gamma(T_{\{\bar{c}\bar{c}\}}^{\{bb\}} \rightarrow X)$  can be rewritten as

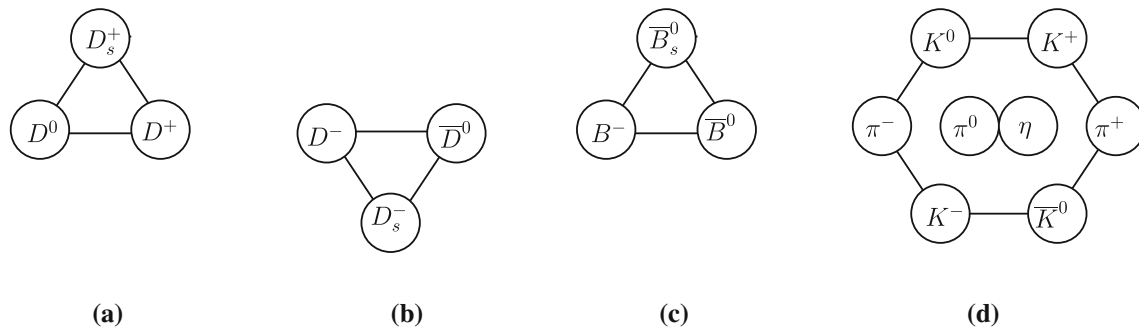

**Fig. 1** The weight diagrams for the anti-charmed meson triplet, charmed meson anti-triplet, bottom meson triplet and light meson octet

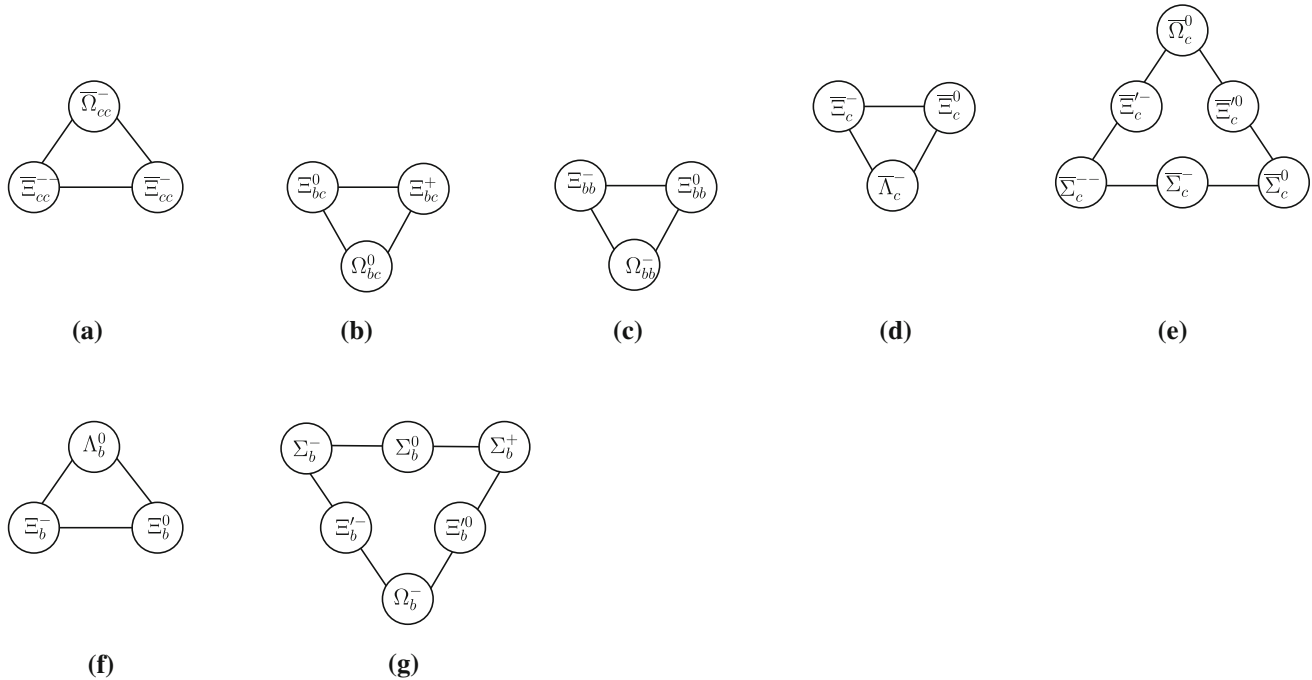

**Fig. 2** The weight diagrams for the doubly heavy baryon are given in **a–c**, which anti-triplet  $\bar{F}_{cc}$  to be **(a)**, triplet  $F_{bc}$  to be **(b)**, or triplet  $F_{bb}$  to be **(c)**. The singly anti-charm baryon multiplets are  $\bar{F}_{c3}$ ,  $\bar{F}_{c6}$  shown in **d**, **e**, and the singly bottom baryon multiplets are given in **f**, **g** signed as  $F_{b3}$ ,  $F_{b6}$

$$\Gamma(T_{\{\bar{c}\bar{c}\}}^{\{bb\}} \rightarrow X) = \frac{1}{2m_T} \sum_{\lambda} \langle T_{\{\bar{c}\bar{c}\}}^{\{bb\}} | T | T_{\{\bar{c}\bar{c}\}}^{\{bb\}} \rangle \quad (6)$$

$$T = Im \int d^4x T \{ \mathcal{H}_{eff}(x) \mathcal{H}_{eff}(0) \} \quad (7)$$

In the heavy quark expansion (HQE), the transition operators up to dimension 6 contribute:

$$T = \sum_{Q=b,c} \frac{G_F^2 m_Q^5}{192\pi^3} |V_{CKM}|^2 \times \left[ c_{3,Q} (\bar{Q}Q) + \frac{c_{5,Q}}{m_Q^2} (\bar{Q}g_s \sigma_{\mu\nu} G^{\mu\nu} Q) + 2 \frac{c_{6,Q}}{m_Q^3} (\bar{Q}q)_{\Gamma} (\bar{q}Q)_{\Gamma} \right], \quad (8)$$

with  $G_F$  being the Fermi constant and  $V_{CKM}$  being the CKM mixing matrix. The coefficients  $c_{i,Q}$  are the perturbative short-distance coefficients. The contribution to decay width from the lowest dimension operator is given as

$$\Gamma(T_{\{\bar{c}\bar{c}\}}^{\{bb\}} \rightarrow X) = \sum_{Q=b,c} \frac{G_F^2 m_Q^5}{192\pi^3} |V_{CKM}|^2 c_{3,Q} \frac{\langle T_{\{\bar{c}\bar{c}\}}^{\{bb\}} | \bar{Q}Q | T_{\{\bar{c}\bar{c}\}}^{\{bb\}} \rangle}{2m_T}, \quad (9)$$

where the matrix element

$$\frac{\langle T_{\{\bar{c}\bar{c}\}}^{\{bb\}} | \bar{Q}Q | T_{\{\bar{c}\bar{c}\}}^{\{bb\}} \rangle}{2m_T} \quad (10)$$

corresponds to the bottom and charmed number in the tetraquark state. The matrix elements of the  $\bar{b}b$  operator and

the  $\bar{c}c$  operator give the bottom-quark and charm-quark number in the  $T_{\{\bar{c}c\}}^{(bb)}$  tetraquark respectively given as

$$\frac{\langle T_{\{\bar{c}c\}}^{(bb)} | \bar{b}b | T_{\{\bar{c}c\}}^{(bb)} \rangle}{2m_T} = 2 + \mathcal{O}(1/m_b),$$

$$\frac{\langle T_{\{\bar{c}c\}}^{(bb)} | \bar{c}c | T_{\{\bar{c}c\}}^{(bb)} \rangle}{2m_T} = 2 + \mathcal{O}(1/m_c). \tag{11}$$

The short distance coefficients  $c_{3,Q}$ s have been calculated as  $c_{3,b} = 5.29 \pm 0.35$ ,  $c_{3,c} = 6.29 \pm 0.72$  at the leading order(LO) and  $c_{3,b} = 6.88 \pm 0.74$ ,  $c_{3,c} = 11.61 \pm 1.55$  at the next-to-leading order(NLO) [63]. Therefore we expect that the total decay width and lifetime of the  $T_{\{\bar{c}c\}}^{(bb)}$  tetraquark as

$$\Gamma(T_{\{\bar{c}c\}}^{(bb)}) = \begin{cases} (2.44 \pm 0.23) \times 10^{-12} \text{ GeV, LO} \\ (3.97 \pm 1.50) \times 10^{-12} \text{ GeV, NLO} \end{cases}, \tag{12}$$

$$\tau(T_{\{\bar{c}c\}}^{(bb)}) = \begin{cases} (0.27 \pm 0.02) \times 10^{-12} \text{ s, LO} \\ (0.17 \pm 0.02) \times 10^{-12} \text{ s, NLO} \end{cases}, \tag{13}$$

where we use the heavy quark masses  $m_c = 1.4 \text{ GeV}$  and  $m_b = 4.8 \text{ GeV}$ . The lifetime of  $T_{\{\bar{c}c\}}^{(bb)}$  is much smaller than that of  $B_c$  meson

$$\tau(B_c^+) = 0.507 \times 10^{-12} \text{ s}, \tag{14}$$

and in particular, their ratio is about one third.

#### 4 Weak decays

In this section, we will discuss the possible weak decay modes of the tetraquark. Usually, the  $b$  and  $c$  quark in tetraquark state can decay weakly. For simplicity, we will classify the decays modes by the quantities of CKM matrix elements.

- For the  $b/c$  quark decays into lepton pair, semi-leptonic decay process, we consider the following groups.

$$b \rightarrow c/u\ell^-\bar{\nu}_\ell, \quad \bar{c} \rightarrow \bar{d}/\bar{s}\ell^-\bar{\nu}_\ell. \tag{15}$$

The general electro-weak Hamiltonian for the above semi-leptonic transition can be expressed as

$$\mathcal{H}_{eff} = \frac{G_F}{\sqrt{2}} [V_{q'b}\bar{q}'\gamma^\mu(1-\gamma_5)b\bar{\ell}\gamma_\mu(1-\gamma_5)\nu_\ell + V_{cq}\bar{c}\gamma^\mu(1-\gamma_5)q\bar{\ell}\gamma_\mu(1-\gamma_5)\nu_\ell] + h.c., \tag{16}$$

with  $q' = (u, c)$ ,  $q = (d, s)$ , in which the operator of  $b \rightarrow u/c\ell^-\bar{\nu}_\ell$  transition forms an SU(3) flavor triplet  $H'_3$  or singlet, with  $(H'_3)^1 = 1$  and  $(H'_3)^{2,3} = 0$ . Furthermore, it is easy to see that the  $\bar{c} \rightarrow \bar{q}\ell^-\bar{\nu}$  transition

forms a triplet  $H_3$ , particularly  $(H_3)_1 = 0$ ,  $(H_3)_2 = V_{cd}$ ,  $(H_3)_3 = V_{cs}$ .

- The  $c$  quark non-leptonic decays are classified as

$$\bar{c} \rightarrow \bar{s}d\bar{u}, \quad \bar{c} \rightarrow \bar{u}d\bar{d}/s\bar{s}, \quad \bar{c} \rightarrow \bar{d}s\bar{u}, \tag{17}$$

The three kinds of decays are Cabibbo allowed, singly Cabibbo suppressed, and doubly Cabibbo suppressed respectively. Under the flavor SU(3) symmetry, the transition  $\bar{c} \rightarrow \bar{q}_1q_2\bar{q}_3$  can be decomposed as  $\bar{\mathbf{3}} \otimes \mathbf{3} \otimes \bar{\mathbf{3}} = \bar{\mathbf{3}} \oplus \bar{\mathbf{3}} \oplus \mathbf{6} \oplus \bar{\mathbf{15}}$ . For the Cabibbo allowed transition  $\bar{c} \rightarrow \bar{s}d\bar{u}$ , the nonzero tensor components are given as

$$(H_6)_{31}^2 = -(H_6)_{13}^2 = 1, \quad (H_{15})_{31}^2 = (H_{15})_{13}^2 = 1. \tag{18}$$

For the singly Cabibbo suppressed transition  $\bar{c} \rightarrow \bar{u}d\bar{d}$  and  $\bar{c} \rightarrow \bar{u}s\bar{s}$ , the combination of tensor components are given as

$$(H_6)_{21}^3 = -(H_6)_{12}^3 = (H_6)_{12}^2 = -(H_6)_{21}^2 = \sin(\theta_C),$$

$$(H_{15})_{21}^3 = (H_{15})_{12}^3 = -(H_{15})_{12}^2 = -(H_{15})_{21}^2 = \sin(\theta_C). \tag{19}$$

while for the doubly Cabibbo suppressed transition  $\bar{c} \rightarrow \bar{d}s\bar{u}$ , we have

$$(H_6)_{21}^3 = -(H_6)_{12}^3 = -\sin^2\theta_C,$$

$$(H_{15})_{21}^3 = (H_{15})_{12}^3 = -\sin^2\theta_C. \tag{20}$$

- The  $b$  quark non-leptonic decays are classified as:

$$b \rightarrow c\bar{c}d/s, \quad b \rightarrow c\bar{u}d/s, \quad b \rightarrow u\bar{c}d/s, \quad b \rightarrow q_1\bar{q}_2q_3, \tag{21}$$

here  $q_{1,2,3}$  represent the light quark( $d/s$ ).

The transition operator for the  $b \rightarrow c\bar{c}d/s$  forms an triplet, with  $(H_3)^2 = V_{cd}^*$ ,  $(H_3)^3 = V_{cs}^*$ . The operator of the transition  $b \rightarrow c\bar{u}d/s$  can form an octet  $\mathbf{8}$ , whose nonzero composition followed as  $(H_8)_1^2 = V_{ud}^*$ ,  $(H_8)_1^3 = V_{us}^*$ . For the transition  $b \rightarrow u\bar{c}s$ , the operator can form an anti-symmetric  $\bar{\mathbf{3}}$  with  $(H'_3)^{13} = -(H'_3)^{31} = V_{cs}^*$  plus a symmetric  $\mathbf{6}$  tensors with  $(H_6)^{13} = (H_6)^{31} = V_{cs}^*$ . It is straightforward to obtain the similar transition  $b \rightarrow u\bar{c}d$  by exchanging the index  $2 \rightarrow 3$  and the  $V_{cs} \rightarrow V_{cd}$  in previous transition.

The charmless transition  $b \rightarrow q_1\bar{q}_2q_3$  ( $q_i = d, s$ ) can be decomposed as  $\mathbf{3} \otimes \bar{\mathbf{3}} \otimes \mathbf{3} = \mathbf{3} \oplus \mathbf{3} \oplus \bar{\mathbf{6}} \oplus \mathbf{15}$ , where the triplet  $H_3$  behave as the penguin level operator. In

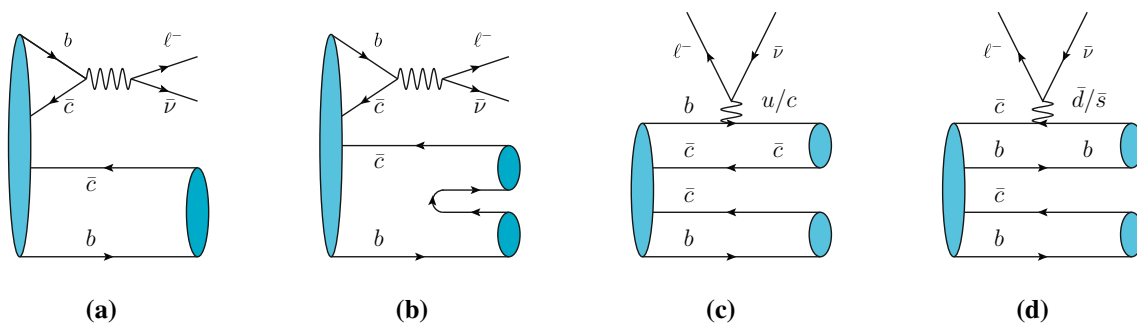

**Fig. 3** Feynman diagrams for  $T_{\{\bar{c}\bar{c}\}}^{\{bb\}}$  semi-leptonic decays within  $b/\bar{c}$  quark decay. Panel **a** represents a meson final state, while the panel **b–d** correspond with two mesons final states. In panel **a, b**, the quarks in initial state interact by the exchange of W boson

the  $\Delta S = 0(b \rightarrow d)$  decays, the nonzero components of these irreducible tensors are given as

$$\begin{aligned} (H_3)^2 &= 1, & (H_6)_1^{12} &= -(H_6)_1^{21} \\ &= (H_6)_3^{23} &= -(H_6)_3^{32} &= 1, \\ 2(H_{15})_1^{12} &= 2(H_{15})_1^{21} &= -3(H_{15})_2^{22} \\ &= -6(H_{15})_3^{23} &= -6(H_{15})_3^{32} &= 6. \end{aligned} \tag{22}$$

For the  $\Delta S = 1(b \rightarrow s)$  decays, the nonzero entries in the irreducible tensor  $H_3, H_6, H_{15}$  can be obtained from Eq. (22) with the exchange  $2 \leftrightarrow 3$ .

In the following, we will study the possible decay modes of  $T_{\{\bar{c}\bar{c}\}}^{\{bb\}}$  in order.

### 4.1 Semi-leptonic $T_{\{\bar{c}\bar{c}\}}^{\{bb\}}$ decays

#### 4.1.1 $b \rightarrow c/u\ell^-\bar{\nu}_\ell$ transition

At the hadron level, the  $b \rightarrow u$  transition can be realized by the process that  $T_{\{\bar{c}\bar{c}\}}^{\{bb\}}$  decays to a anti-charmed meson plus  $B_c$  meson and  $\ell\bar{\nu}_\ell$ . Following the SU(3) analysis, the Hamiltonian at the hadronic level is constructed as  $a_1 T_{\{\bar{c}\bar{c}\}}^{\{bb\}} (H_3^i)^j D_i \bar{B}_c \bar{\ell} \nu$ , with the coefficient  $a_1$  representing the non-perturbative parameter. For completeness, we give the corresponding Feynman diagram at quark level shown in Fig. 3c. It is convenient to obtain the decay amplitudes by expanding the Hamiltonian constructed above and the amplitude  $\mathcal{M}(T_{\{\bar{c}\bar{c}\}}^{\{bb\}} \rightarrow \bar{D}^0 B_c^- \ell^- \bar{\nu}) = a_1 V_{ub}$ .

For the SU(3) singlet  $b \rightarrow c$  transition, the final hadrons of the many-body semileptonic decays of  $T_{\{\bar{c}\bar{c}\}}^{\{bb\}}$  can be a  $B_c$  meson,  $B_c$  plus  $J/\psi$ , charmed meson plus bottom meson respectively. Consequently, the Hamiltonian at the hadron level is constructed as

$$\begin{aligned} \mathcal{H}_{eff} &= a_2 T_{\{\bar{c}\bar{c}\}}^{\{bb\}} \bar{B}_c \bar{\ell} \nu + a_3 T_{\{\bar{c}\bar{c}\}}^{\{bb\}} \bar{B}_c J/\psi \bar{\ell} \nu \\ &+ a_4 T_{\{\bar{c}\bar{c}\}}^{\{bb\}} D_i \bar{B}^i \bar{\ell} \nu. \end{aligned} \tag{23}$$

**Table 1** Amplitudes for tetraquark  $T_{\{\bar{c}\bar{c}\}}^{\{bb\}}$  decays into two mesons and three mesons for the transition  $b \rightarrow c\ell^-\bar{\nu}$

Channel	Amplitude	Channel	Amplitude
$T_{\{\bar{c}\bar{c}\}}^{\{bb\}} \rightarrow B_c \ell^- \bar{\nu}$	$a_2 V_{cb}$	$T_{\{\bar{c}\bar{c}\}}^{\{bb\}} \rightarrow B_c J/\psi \ell^- \bar{\nu}$	$a_3 V_{cb}$
$T_{\{\bar{c}\bar{c}\}}^{\{bb\}} \rightarrow \bar{D}^0 B^- \ell^- \bar{\nu}$	$a_4 V_{cb}$	$T_{\{\bar{c}\bar{c}\}}^{\{bb\}} \rightarrow D^- \bar{B}^0 \ell^- \bar{\nu}$	$a_4 V_{cb}$
$T_{\{\bar{c}\bar{c}\}}^{\{bb\}} \rightarrow D_s^- \bar{B}_s^0 \ell^- \bar{\nu}$	$a_4 V_{cb}$		

Feynman diagrams are shown in Fig. 3a, b. One then obtain the amplitudes of different decay channels listed in Table 1, from which we derive that the simple relations between different decay widths as:  $\Gamma(T_{\{\bar{c}\bar{c}\}}^{\{bb\}} \rightarrow \bar{D}^0 B^- \ell^- \bar{\nu}) = \Gamma(T_{\{\bar{c}\bar{c}\}}^{\{bb\}} \rightarrow D^- \bar{B}^0 \ell^- \bar{\nu}) = \Gamma(T_{\{\bar{c}\bar{c}\}}^{\{bb\}} \rightarrow D_s^- \bar{B}_s^0 \ell^- \bar{\nu})$ .

#### 4.1.2 $\bar{c} \rightarrow \bar{d}/\bar{s}\ell^-\bar{\nu}_\ell$ transition

Similarly, one can find the allowed process in hadronic level for the  $\bar{c} \rightarrow \bar{d}/\bar{s}\ell^-\bar{\nu}_\ell$  transition. For the channels with the  $B$  meson plus  $B_c$  meson in the final state, we construct the Hamiltonian as  $c_1 T_{\{\bar{c}\bar{c}\}}^{\{bb\}} (H_3)_i^j \bar{B}^i \bar{B}_c \bar{\ell} \nu$ . Then the decay amplitudes are deduced as  $\mathcal{M}(T_{\{\bar{c}\bar{c}\}}^{\{bb\}} \rightarrow \bar{B}^0 B_c^- \ell^- \bar{\nu}) = c_1 V_{cd}$ ,  $\mathcal{M}(T_{\{\bar{c}\bar{c}\}}^{\{bb\}} \rightarrow \bar{B}_s^0 B_c^- \ell^- \bar{\nu}) = c_1 V_{cs}$ . For completeness, we give the corresponding Feynman diagram given in Fig. 3d.

### 4.2 $T_{\{\bar{c}\bar{c}\}}^{\{bb\}}$ : non-leptonic multi-body decays

#### 4.2.1 $b \rightarrow c\bar{c}d/s$ transition

The operators in the transition can form an triplet under the SU(3) light quark symmetry, and accordingly, we can write down the effective Hamiltonian of  $T_{\{\bar{c}\bar{c}\}}^{\{bb\}}$  producing two or three final states as follows:

$$\begin{aligned} \mathcal{H}_{eff} &= a_1 T_{\{\bar{c}\bar{c}\}}^{\{bb\}} (H_3)^i D_i \bar{B}_c, \\ \mathcal{H}_{eff} &= a_2 T_{\{\bar{c}\bar{c}\}}^{\{bb\}} (H_3)^i D_i J/\psi \bar{B}_c + a_3 T_{\{\bar{c}\bar{c}\}}^{\{bb\}} (H_3)^i D_j M_i^j \bar{B}_c \end{aligned}$$

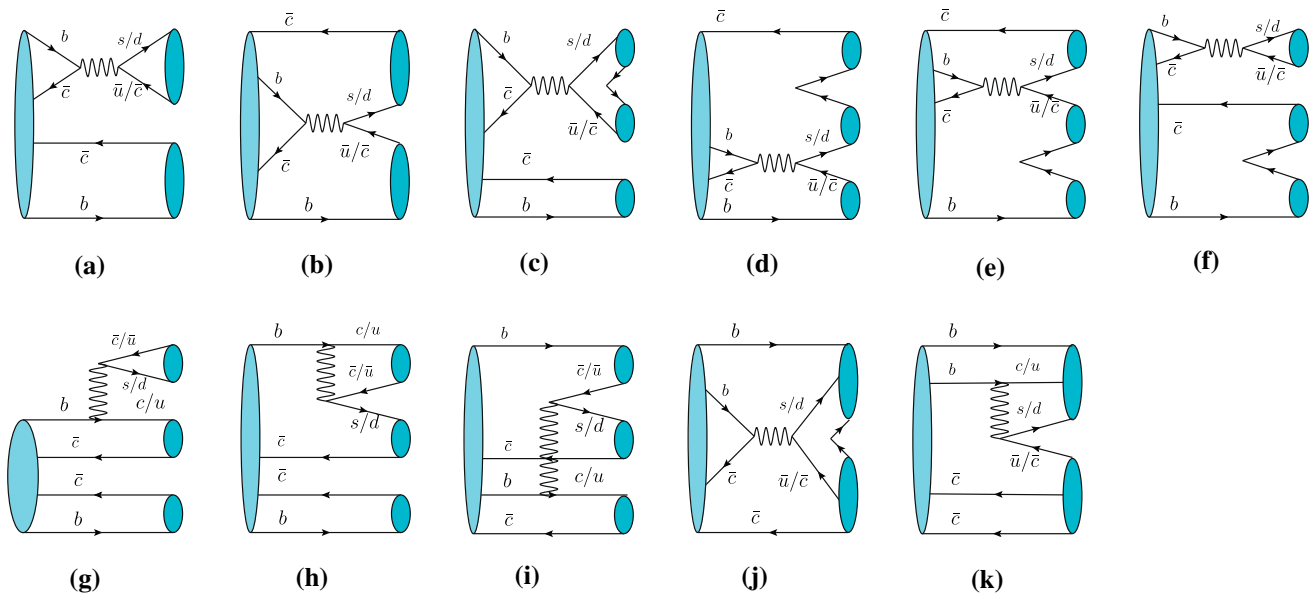

**Fig. 4** The Feynman diagrams for  $T_{\{\bar{c}\bar{c}\}}^{(bb)}$  non-leptonic decays within  $b$  quark decay. Panels **a, b** represent the two-body mesonic decays, two-body baryonic decays are shown in panels **j, k** and the panels **c–i** indicate the three-body mesonic decays

$$\begin{aligned}
 &+a_4 T_{\{\bar{c}\bar{c}\}}^{(bb)} (H_3)^i D_i D_j \bar{B}^j, \\
 \mathcal{H}_{eff} = &a_5 T_{\{\bar{c}\bar{c}\}}^{(bb)} (H_3)^i (F_{cc})^j (\bar{F}_{b3})_{[ij]} \\
 &+a_6 T_{\{\bar{c}\bar{c}\}}^{(bb)} (H_3)^i (F_{cc})^j (\bar{F}_{b\bar{6}})_{[ij]} \\
 &+a_7 T_{\{\bar{c}\bar{c}\}}^{(bb)} (H_3)^i (\bar{F}_{bc})_i F_{ccc}. \tag{24}
 \end{aligned}$$

The corresponding Feynman diagrams are given in Fig. 4. In particular, the diagrams in Fig. 4a, b represent  $T_{\{\bar{c}\bar{c}\}}^{(bb)}$  two-body mesonic decays into anti-charmed and  $B_c$  mesons, and the diagrams in Fig. 4c, d denote the three-body final states with anti-charmed meson plus  $B_c$  meson and a light meson. In addition, the  $a_3$  term in Hamiltonian with the final states of two anti-charmed mesons plus  $B$  meson and the  $a_4$  term with the final states of a anti-charmed meson plus  $B_c$  meson and  $J/\psi$  are represented in several Feynman diagrams which given in Fig. 4e, f; g–i respectively. The two-body baryonic processes induced from  $a_5, a_6, a_7$  terms are shown in Fig. 4j, k. Expanding the Hamiltonian above, one obtains the decay amplitudes which are listed in Table 2, Table 3. Besides, the relations between the different decay widths are given as follows.

$$\begin{aligned}
 \Gamma(T_{\{\bar{c}\bar{c}\}}^{(bb)} \rightarrow \bar{D}^0 B_c^- \pi^-) &= 6\Gamma(T_{\{\bar{c}\bar{c}\}}^{(bb)} \rightarrow D^- B_c^- \eta) \\
 &= \Gamma(T_{\{\bar{c}\bar{c}\}}^{(bb)} \rightarrow D_s^- B_c^- K^0) = 2\Gamma(T_{\{\bar{c}\bar{c}\}}^{(bb)} \rightarrow D^- B_c^- \pi^0), \\
 \Gamma(T_{\{\bar{c}\bar{c}\}}^{(bb)} \rightarrow \bar{D}^0 B_c^- K^-) &= \frac{3}{2}\Gamma(T_{\{\bar{c}\bar{c}\}}^{(bb)} \rightarrow D_s^- B_c^- \eta) \\
 &= \Gamma(T_{\{\bar{c}\bar{c}\}}^{(bb)} \rightarrow D^- B_c^- \bar{K}^0), \\
 \Gamma(T_{\{\bar{c}\bar{c}\}}^{(bb)} \rightarrow B^- \bar{D}^0 D^-) &= \Gamma(T_{\{\bar{c}\bar{c}\}}^{(bb)} \rightarrow \bar{B}_s^0 D^- D_s^-) \\
 &= \frac{1}{2}\Gamma(T_{\{\bar{c}\bar{c}\}}^{(bb)} \rightarrow \bar{B}^0 D^- D^-),
 \end{aligned}$$

$$\begin{aligned}
 \Gamma(T_{\{\bar{c}\bar{c}\}}^{(bb)} \rightarrow B^- \bar{D}^0 D_s^-) &= \Gamma(T_{\{\bar{c}\bar{c}\}}^{(bb)} \rightarrow \bar{B}^0 D^- D_s^-) \\
 &= \frac{1}{2}\Gamma(T_{\{\bar{c}\bar{c}\}}^{(bb)} \rightarrow \bar{B}_s^0 D_s^- D_s^-), \\
 \Gamma(T_{\{\bar{c}\bar{c}\}}^{(bb)} \rightarrow \bar{\Xi}_{cc}^- \Sigma_b^0) &= \frac{1}{2}\Gamma(T_{\{\bar{c}\bar{c}\}}^{(bb)} \rightarrow \bar{\Xi}_{cc}^- \Sigma_b^-) = \Gamma(T_{\{\bar{c}\bar{c}\}}^{(bb)} \rightarrow \bar{\Omega}_{cc}^- \Xi_b^{\prime-}), \\
 \Gamma(T_{\{\bar{c}\bar{c}\}}^{(bb)} \rightarrow \bar{\Xi}_{cc}^- \Xi_b^{\prime0}) &= \Gamma(T_{\{\bar{c}\bar{c}\}}^{(bb)} \rightarrow \bar{\Xi}_{cc}^- \Xi_b^{\prime-}) \\
 &= \frac{1}{2}\Gamma(T_{\{\bar{c}\bar{c}\}}^{(bb)} \rightarrow \bar{\Omega}_{cc}^- \Omega_b^-), \\
 \Gamma(T_{\{\bar{c}\bar{c}\}}^{(bb)} \rightarrow \bar{\Xi}_{cc}^- \Lambda_b^0) &= \Gamma(T_{\{\bar{c}\bar{c}\}}^{(bb)} \rightarrow \bar{\Omega}_{cc}^- \Xi_b^-), \Gamma(T_{\{\bar{c}\bar{c}\}}^{(bb)} \rightarrow \bar{\Xi}_{cc}^- \Xi_b^0) \\
 &= \Gamma(T_{\{\bar{c}\bar{c}\}}^{(bb)} \rightarrow \bar{\Xi}_{cc}^- \Xi_b^-).
 \end{aligned}$$

#### 4.2.2 $b \rightarrow c\bar{u}d/s$ transition

The hadron-level effective Hamiltonian of two-body and three-body decays can be constructed as

$$\begin{aligned}
 \mathcal{H}_{eff} &= b_1 T_{\{\bar{c}\bar{c}\}}^{(bb)} (H_8)_j^i M_i^j \bar{B}_c + b_2 T_{\{\bar{c}\bar{c}\}}^{(bb)} (H_8)_j^i \bar{B}^j D_i, \\
 \mathcal{H}_{eff} &= b_3 T_{\{\bar{c}\bar{c}\}}^{(bb)} (H_8)_j^i M_i^j J/\psi \bar{B}_c + b_4 T_{\{\bar{c}\bar{c}\}}^{(bb)} (H_8)_j^i \bar{D}^j D_i \bar{B}_c \\
 &+ b_5 T_{\{\bar{c}\bar{c}\}}^{(bb)} (H_8)_j^i \bar{B}^j D_i J/\psi \\
 &+ b_6 T_{\{\bar{c}\bar{c}\}}^{(bb)} (H_8)_j^i \bar{B}^j D_k M_i^k + b_7 T_{\{\bar{c}\bar{c}\}}^{(bb)} (H_8)_k^i \bar{B}^j D_j M_i^k \\
 &+ b_8 T_{\{\bar{c}\bar{c}\}}^{(bb)} (H_8)_k^i \bar{B}^j D_i M_j^k \\
 &+ b_9 T_{\{\bar{c}\bar{c}\}}^{(bb)} (H_8)_j^i \bar{B}_c M_i^k M_k^j, \\
 \mathcal{H}_{eff} &= b_{10} T_{\{\bar{c}\bar{c}\}}^{(bb)} (H_8)_j^i (F_{\bar{c}\bar{3}})^{[jk]} (\bar{F}_{b3})_{[ik]}
 \end{aligned}$$

**Table 2** Tetraquark  $T_{\{\bar{c}\bar{c}\}}^{(bb)}$  decays into two and three mesons for the transition  $b \rightarrow c\bar{c}d/s$

Channel	Amplitude	Channel	Amplitude
$T_{\{\bar{c}\bar{c}\}}^{(bb)} \rightarrow D^- B_c^-$	$a_1 V_{cd}^*$	$T_{\{\bar{c}\bar{c}\}}^{(bb)} \rightarrow D_s^- B_c^-$	$a_1 V_{cs}^*$
$T_{\{\bar{c}\bar{c}\}}^{(bb)} \rightarrow D^- B_c^- J/\psi$	$a_2 V_{cd}^*$	$T_{\{\bar{c}\bar{c}\}}^{(bb)} \rightarrow D_s^- B_c^- J/\psi$	$a_2 V_{cs}^*$
$T_{\{\bar{c}\bar{c}\}}^{(bb)} \rightarrow \bar{D}^0 D^- B^-$	$a_4 V_{cd}^*$	$T_{\{\bar{c}\bar{c}\}}^{(bb)} \rightarrow \bar{D}^0 D_s^- B^-$	$a_4 V_{cs}^*$
$T_{\{\bar{c}\bar{c}\}}^{(bb)} \rightarrow D^- D^- \bar{B}^0$	$2a_4 V_{cd}^*$	$T_{\{\bar{c}\bar{c}\}}^{(bb)} \rightarrow D^- D_s^- \bar{B}^0$	$a_4 V_{cs}^*$
$T_{\{\bar{c}\bar{c}\}}^{(bb)} \rightarrow D^- D_s^- \bar{B}_s^0$	$a_4 V_{cd}^*$	$T_{\{\bar{c}\bar{c}\}}^{(bb)} \rightarrow D_s^- D_s^- \bar{B}_s^0$	$2a_4 V_{cs}^*$
$T_{\{\bar{c}\bar{c}\}}^{(bb)} \rightarrow \bar{D}^0 B_c^- \pi^-$	$a_3 V_{cd}^*$	$T_{\{\bar{c}\bar{c}\}}^{(bb)} \rightarrow \bar{D}^0 B_c^- K^-$	$a_3 V_{cs}^*$
$T_{\{\bar{c}\bar{c}\}}^{(bb)} \rightarrow D^- B_c^- \pi^0$	$-\frac{a_3 V_{cd}^*}{\sqrt{2}}$	$T_{\{\bar{c}\bar{c}\}}^{(bb)} \rightarrow D^- B_c^- \bar{K}^0$	$a_3 V_{cs}^*$
$T_{\{\bar{c}\bar{c}\}}^{(bb)} \rightarrow D^- B_c^- \eta$	$\frac{a_3 V_{cd}^*}{\sqrt{6}}$	$T_{\{\bar{c}\bar{c}\}}^{(bb)} \rightarrow D_s^- B_c^- K^0$	$a_3 V_{cd}^*$
$T_{\{\bar{c}\bar{c}\}}^{(bb)} \rightarrow D_s^- B_c^- \eta$	$-\sqrt{\frac{2}{3}} a_3 V_{cs}^*$		

**Table 3** Tetraquark  $T_{\{\bar{c}\bar{c}\}}^{(bb)}$  decays into doubly charmed baryon plus singly bottom baryon for the transition of  $b \rightarrow c\bar{c}d/s$

Channel	Amplitude	Channel	Amplitude
$T_{\{\bar{c}\bar{c}\}}^{(bb)} \rightarrow \bar{\Xi}_{cc}^- \Lambda_b^0$	$-a_5 V_{cd}^*$	$T_{\{\bar{c}\bar{c}\}}^{(bb)} \rightarrow \bar{\Xi}_{cc}^- \Xi_b^0$	$-a_5 V_{cs}^*$
$T_{\{\bar{c}\bar{c}\}}^{(bb)} \rightarrow \bar{\Xi}_{cc}^- \Xi_b^-$	$-a_5 V_{cs}^*$	$T_{\{\bar{c}\bar{c}\}}^{(bb)} \rightarrow \bar{\Omega}_{cc}^- \Xi_b^-$	$a_5 V_{cd}^*$
$T_{\{\bar{c}\bar{c}\}}^{(bb)} \rightarrow \bar{\Xi}_{cc}^- \Sigma_b^0$	$\frac{a_6 V_{cd}^*}{\sqrt{2}}$	$T_{\{\bar{c}\bar{c}\}}^{(bb)} \rightarrow \bar{\Xi}_{cc}^- \Xi_b'^0$	$\frac{a_6 V_{cs}^*}{\sqrt{2}}$
$T_{\{\bar{c}\bar{c}\}}^{(bb)} \rightarrow \bar{\Xi}_{cc}^- \Sigma_b^-$	$a_6 V_{cd}^*$	$T_{\{\bar{c}\bar{c}\}}^{(bb)} \rightarrow \bar{\Xi}_{cc}^- \Xi_b'^-$	$\frac{a_6 V_{cs}^*}{\sqrt{2}}$
$T_{\{\bar{c}\bar{c}\}}^{(bb)} \rightarrow \bar{\Omega}_{cc}^- \Xi_b'^-$	$\frac{a_6 V_{cd}^*}{\sqrt{2}}$	$T_{\{\bar{c}\bar{c}\}}^{(bb)} \rightarrow \bar{\Omega}_{cc}^- \Omega_b^-$	$a_6 V_{cs}^*$
$T_{\{\bar{c}\bar{c}\}}^{(bb)} \rightarrow \Xi_b^0 \bar{\Omega}_{ccc}^-$	$a_7 V_{cd}^*$	$T_{\{\bar{c}\bar{c}\}}^{(bb)} \rightarrow \Omega_b^0 \bar{\Omega}_{ccc}^-$	$a_7 V_{cs}^*$

$$\begin{aligned}
 &+ b_{11} T_{\{\bar{c}\bar{c}\}}^{(bb)} (H_8)_j^i (F_{c\bar{3}})^{[jk]} (\bar{F}_{b\bar{6}})_{[ik]} \\
 &+ b_{12} T_{\{\bar{c}\bar{c}\}}^{(bb)} (H_8)_j^i (F_{c6})^{[jk]} (\bar{F}_{b3})_{[ik]} \\
 &+ b_{13} T_{\{\bar{c}\bar{c}\}}^{(bb)} (H_8)_j^i (F_{c6})^{[jk]} (\bar{F}_{b\bar{6}})_{[ik]} \\
 &+ b_{14} T_{\{\bar{c}\bar{c}\}}^{(bb)} (H_8)_j^i (F_{cc})^j (\bar{F}_{bc})_i.
 \end{aligned} \tag{25}$$

At the topological level, the relevant Feynman diagrams are shown in Fig. 4. One derives the decay amplitudes given in Tables 4 and 5, respectively. Accordingly, we obtain the relations between different decay widths as follows:

$$\begin{aligned}
 \Gamma(T_{\{\bar{c}\bar{c}\}}^{(bb)} \rightarrow B_c^- \pi^0 K^-) &= 3\Gamma(T_{\{\bar{c}\bar{c}\}}^{(bb)} \rightarrow B_c^- K^- \eta) \\
 &= \frac{1}{2} \Gamma(T_{\{\bar{c}\bar{c}\}}^{(bb)} \rightarrow B_c^- \pi^- \bar{K}^0), \\
 \Gamma(T_{\{\bar{c}\bar{c}\}}^{(bb)} \rightarrow B_c^- K^0 K^-) &= \frac{3}{2} \Gamma(T_{\{\bar{c}\bar{c}\}}^{(bb)} \\
 &\rightarrow B_c^- \pi^- \eta), \Gamma(T_{\{\bar{c}\bar{c}\}}^{(bb)} \rightarrow B^- D_s^- \pi^0) \\
 &= \frac{1}{2} \Gamma(T_{\{\bar{c}\bar{c}\}}^{(bb)} \rightarrow \bar{B}^0 D_s^- \pi^-), \\
 \Gamma(T_{\{\bar{c}\bar{c}\}}^{(bb)} \rightarrow \bar{\Sigma}_c^- \Sigma_b^0) &= \Gamma(T_{\{\bar{c}\bar{c}\}}^{(bb)} \rightarrow \bar{\Sigma}_c^- \Sigma_b^-)
 \end{aligned}$$

$$\begin{aligned}
 &= 2\Gamma(T_{\{\bar{c}\bar{c}\}}^{(bb)} \rightarrow \bar{\Xi}_c'^- \Xi_b'^-), \\
 \Gamma(T_{\{\bar{c}\bar{c}\}}^{(bb)} \rightarrow \bar{\Sigma}_c^- \Xi_b^0) &= 2\Gamma(T_{\{\bar{c}\bar{c}\}}^{(bb)} \rightarrow \bar{\Sigma}_c^- \Xi_b'^-), \\
 &= \Gamma(T_{\{\bar{c}\bar{c}\}}^{(bb)} \rightarrow \bar{\Xi}_c'^- \Omega_b^-), \\
 \Gamma(T_{\{\bar{c}\bar{c}\}}^{(bb)} \rightarrow \bar{\Lambda}_c^- \Sigma_b^-) &= 2\Gamma(T_{\{\bar{c}\bar{c}\}}^{(bb)} \rightarrow \bar{\Xi}_c^- \Xi_b'^-), \\
 \Gamma(T_{\{\bar{c}\bar{c}\}}^{(bb)} \rightarrow \bar{\Lambda}_c^- \Xi_b'^-) \\
 &= \frac{1}{2} \Gamma(T_{\{\bar{c}\bar{c}\}}^{(bb)} \rightarrow \bar{\Xi}_c^- \Omega_b^-), \\
 \Gamma(T_{\{\bar{c}\bar{c}\}}^{(bb)} \rightarrow \bar{\Sigma}_c^- \Lambda_b^0) &= 2\Gamma(T_{\{\bar{c}\bar{c}\}}^{(bb)} \rightarrow \bar{\Xi}_c'^- \Xi_b^-), \\
 \Gamma(T_{\{\bar{c}\bar{c}\}}^{(bb)} \rightarrow \bar{\Sigma}_c^- \Xi_b^0) \\
 &= 2\Gamma(T_{\{\bar{c}\bar{c}\}}^{(bb)} \rightarrow \bar{\Sigma}_c^- \Xi_b^-).
 \end{aligned}$$

### 4.2.3 $b \rightarrow u\bar{c}d/s$ transition

The effective Hamiltonian at the hadron level for  $T_{\{\bar{c}\bar{c}\}}^{(bb)}$  producing three mesons or two baryons are constructed as

$$\begin{aligned}
 \mathcal{H}_{eff} &= c_1 T_{\{\bar{c}\bar{c}\}}^{(bb)} (H_6)^{[ij]} D_i D_j \bar{B}_c, \\
 \mathcal{H}_{eff} &= c_2 T_{\{\bar{c}\bar{c}\}}^{(bb)} (H_3)^{[ij]} (\bar{F}_{b3})_{[ij]} F_{ccc} \\
 &\quad + c_3 T_{\{\bar{c}\bar{c}\}}^{(bb)} (H_6)^{[ij]} (\bar{F}_{b\bar{6}})_{[ij]} F_{ccc}.
 \end{aligned} \tag{26}$$

It should be noticed that the operator  $H_3$  in mesonic process vanishes as the two antisymmetry superscripts contract with the two symmetry anti-charmed fields. Though the Hamiltonian for the mesonic process follows only  $c_1$  term, the corresponding Feynman diagrams can be allowed with different topologies given in Fig. 4g–i. One then proceed to obtain the decay amplitudes  $\mathcal{M}(T_{\{\bar{c}\bar{c}\}}^{(bb)} \rightarrow \bar{D}^0 D^- B_c^-) = 2c_1 V_{cd}^*$ ,  $\mathcal{M}(T_{\{\bar{c}\bar{c}\}}^{(bb)} \rightarrow \bar{D}^0 D_s^- B_c^-) = 2c_1 V_{cs}^*$  for the mesonic processes and  $\mathcal{M}(T_{\{\bar{c}\bar{c}\}}^{(bb)} \rightarrow \Lambda_b^0 \bar{\Omega}_{ccc}^-) = 2c_2 V_{cd}^*$ ,  $\mathcal{M}(T_{\{\bar{c}\bar{c}\}}^{(bb)} \rightarrow \Xi_b^0 \bar{\Omega}_{ccc}^-) = 2c_2 V_{cs}^*$ ,  $\mathcal{M}(T_{\{\bar{c}\bar{c}\}}^{(bb)} \rightarrow \Sigma_b^0 \bar{\Omega}_{ccc}^-) = \sqrt{2} c_3 V_{cd}^*$ ,  $\mathcal{M}(T_{\{\bar{c}\bar{c}\}}^{(bb)} \rightarrow \Xi_b'^0 \bar{\Omega}_{ccc}^-) = \sqrt{2} c_3 V_{cs}^*$  for the baryonic processes, from which we derive the equation as

$$\begin{aligned}
 \frac{\Gamma(T_{\{\bar{c}\bar{c}\}}^{(bb)} \rightarrow \bar{D}^0 D^- B_c^-)}{\Gamma(T_{\{\bar{c}\bar{c}\}}^{(bb)} \rightarrow \bar{D}^0 D_s^- B_c^-)} &= \frac{\Gamma(T_{\{\bar{c}\bar{c}\}}^{(bb)} \rightarrow \Lambda_b^0 \bar{\Omega}_{ccc}^-)}{\Gamma(T_{\{\bar{c}\bar{c}\}}^{(bb)} \rightarrow \Xi_b^0 \bar{\Omega}_{ccc}^-)} \\
 &= \frac{\Gamma(T_{\{\bar{c}\bar{c}\}}^{(bb)} \rightarrow \Sigma_b^0 \bar{\Omega}_{ccc}^-)}{\Gamma(T_{\{\bar{c}\bar{c}\}}^{(bb)} \rightarrow \Xi_b'^0 \bar{\Omega}_{ccc}^-)} = \frac{|V_{cd}|^2}{|V_{cs}|^2}.
 \end{aligned}$$

### 4.2.4 $b \rightarrow q_1 \bar{q}_2 q_3$ charmless transition

At the hadron level, the effective Hamiltonian for  $T_{\{\bar{c}\bar{c}\}}^{(bb)}$  decaying into mesons or baryons is constructed as follows,

$$\begin{aligned}
 \mathcal{H}_{eff} &= d_1 T_{\{\bar{c}\bar{c}\}}^{(bb)} (H_3)^i \bar{B}^j D_i D_j + d_2 T_{\{\bar{c}\bar{c}\}}^{(bb)} (H_{15})_k^{[ij]} \bar{B}^k D_i D_j, \\
 \mathcal{H}_{eff} &= d_3 T_{\{\bar{c}\bar{c}\}}^{(bb)} (H_3)^i M_i^j D_j \bar{B}_c + d_4 T_{\{\bar{c}\bar{c}\}}^{(bb)} (H_6)_k^{[ij]} M_i^k D_j \bar{B}_c
 \end{aligned}$$

**Table 4** Tetraquark  $T_{\{\bar{c}\bar{c}\}}^{(bb)}$  decays into two mesons and three mesons for the transition  $b \rightarrow c\bar{u}d/s$

Channel	Amplitude	Channel	Amplitude
$T_{\{\bar{c}\bar{c}\}}^{(bb)} \rightarrow \pi^- B_c^-$	$b_1 V_{ud}^*$	$T_{\{\bar{c}\bar{c}\}}^{(bb)} \rightarrow K^- B_c^-$	$b_1 V_{us}^*$
$T_{\{\bar{c}\bar{c}\}}^{(bb)} \rightarrow B^- D^-$	$b_2 V_{ud}^*$	$T_{\{\bar{c}\bar{c}\}}^{(bb)} \rightarrow B^- D_s^-$	$b_2 V_{us}^*$
$T_{\{\bar{c}\bar{c}\}}^{(bb)} \rightarrow \pi^- J/\psi B_c^-$	$b_3 V_{ud}^*$	$T_{\{\bar{c}\bar{c}\}}^{(bb)} \rightarrow K^- J/\psi B_c^-$	$b_3 V_{us}^*$
$T_{\{\bar{c}\bar{c}\}}^{(bb)} \rightarrow D^0 D^- B_c^-$	$b_4 V_{ud}^*$	$T_{\{\bar{c}\bar{c}\}}^{(bb)} \rightarrow D^0 D_s^- B_c^-$	$b_4 V_{us}^*$
$T_{\{\bar{c}\bar{c}\}}^{(bb)} \rightarrow B^- D^- J/\psi$	$b_5 V_{ud}^*$	$T_{\{\bar{c}\bar{c}\}}^{(bb)} \rightarrow B^- D_s^- J/\psi$	$b_5 V_{us}^*$
$T_{\{\bar{c}\bar{c}\}}^{(bb)} \rightarrow B^- \bar{D}^0 \pi^-$	$(b_6 + b_7) V_{ud}^*$	$T_{\{\bar{c}\bar{c}\}}^{(bb)} \rightarrow B^- \bar{D}^0 K^-$	$(b_6 + b_7) V_{us}^*$
$T_{\{\bar{c}\bar{c}\}}^{(bb)} \rightarrow B^- D^- \pi^0$	$\frac{(b_8 - b_6) V_{ud}^*}{\sqrt{2}}$	$T_{\{\bar{c}\bar{c}\}}^{(bb)} \rightarrow B^- D^- \bar{K}^0$	$b_6 V_{us}^*$
$T_{\{\bar{c}\bar{c}\}}^{(bb)} \rightarrow B^- D^- \eta$	$\frac{(b_6 + b_8) V_{ud}^*}{\sqrt{6}}$	$T_{\{\bar{c}\bar{c}\}}^{(bb)} \rightarrow B^- D_s^- \pi^0$	$\frac{b_8 V_{us}^*}{\sqrt{2}}$
$T_{\{\bar{c}\bar{c}\}}^{(bb)} \rightarrow B^- D_s^- K^0$	$b_6 V_{ud}^*$	$T_{\{\bar{c}\bar{c}\}}^{(bb)} \rightarrow B^- D_s^- \eta$	$\frac{(b_8 - 2b_6) V_{us}^*}{\sqrt{6}}$
$T_{\{\bar{c}\bar{c}\}}^{(bb)} \rightarrow \bar{B}^0 D^- \pi^-$	$(b_7 + b_8) V_{ud}^*$	$T_{\{\bar{c}\bar{c}\}}^{(bb)} \rightarrow \bar{B}^0 D^- K^-$	$b_7 V_{us}^*$
$T_{\{\bar{c}\bar{c}\}}^{(bb)} \rightarrow \bar{B}^0 D_s^- \pi^-$	$b_8 V_{us}^*$	$T_{\{\bar{c}\bar{c}\}}^{(bb)} \rightarrow \bar{B}_s^0 D^- K^-$	$b_8 V_{ud}^*$
$T_{\{\bar{c}\bar{c}\}}^{(bb)} \rightarrow \bar{B}_s^0 D_s^- \pi^-$	$b_7 V_{ud}^*$	$T_{\{\bar{c}\bar{c}\}}^{(bb)} \rightarrow \bar{B}_s^0 D_s^- K^-$	$(b_7 + b_8) V_{us}^*$
$T_{\{\bar{c}\bar{c}\}}^{(bb)} \rightarrow \pi^0 K^- B_c^-$	$\frac{b_9 V_{us}^*}{\sqrt{2}}$	$T_{\{\bar{c}\bar{c}\}}^{(bb)} \rightarrow \pi^- \bar{K}^0 B_c^-$	$b_9 V_{us}^*$
$T_{\{\bar{c}\bar{c}\}}^{(bb)} \rightarrow \pi^- \eta B_c^-$	$\sqrt{\frac{2}{3}} b_9 V_{ud}^*$	$T_{\{\bar{c}\bar{c}\}}^{(bb)} \rightarrow K^0 K^- B_c^-$	$b_9 V_{ud}^*$
$T_{\{\bar{c}\bar{c}\}}^{(bb)} \rightarrow K^- \eta B_c^-$	$-\frac{b_9 V_{us}^*}{\sqrt{6}}$		

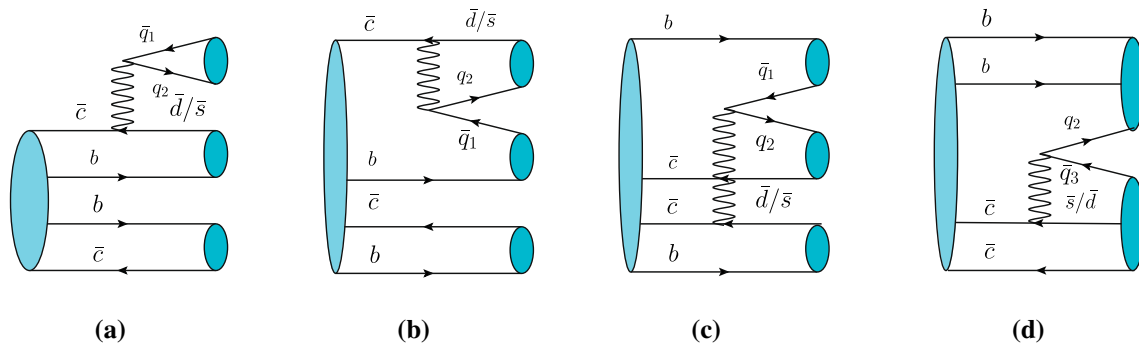

**Fig. 5** The Feynman diagrams for  $T_{\{\bar{c}\bar{c}\}}^{(bb)}$  non-leptonic decays within  $\bar{c}$  quark decay. The lowest allowed many-body charmed decays are three-body mesonic decays shown in panels **a–c** and two-body baryonic decays given in panel **d**

**Table 5** Tetraquark  $T_{\{\bar{c}\bar{c}\}}^{(bb)}$  decays into singly charmed baryon plus singly bottom baryon for the transition  $b \rightarrow c\bar{u}d/s$

Channel	Amplitude	Channel	Amplitude
$T_{\{\bar{c}\bar{c}\}}^{(bb)} \rightarrow \bar{\Lambda}_c^- \Xi_b^-$	$-b_{10} V_{us}^*$	$T_{\{\bar{c}\bar{c}\}}^{(bb)} \rightarrow \bar{\Xi}_c^- \Xi_b^-$	$b_{10} V_{ud}^*$
$T_{\{\bar{c}\bar{c}\}}^{(bb)} \rightarrow \bar{\Lambda}_c^- \Sigma_b^-$	$b_{11} V_{ud}^*$	$T_{\{\bar{c}\bar{c}\}}^{(bb)} \rightarrow \bar{\Lambda}_c^- \Xi_b^-$	$\frac{b_{11} V_{us}^*}{\sqrt{2}}$
$T_{\{\bar{c}\bar{c}\}}^{(bb)} \rightarrow \bar{\Xi}_c^- \Xi_b^-$	$\frac{b_{11} V_{ud}^*}{\sqrt{2}}$	$T_{\{\bar{c}\bar{c}\}}^{(bb)} \rightarrow \bar{\Xi}_c^- \Omega_b^-$	$b_{11} V_{us}^*$
$T_{\{\bar{c}\bar{c}\}}^{(bb)} \rightarrow \bar{\Sigma}_c^- \Lambda_b^0$	$-b_{12} V_{ud}^*$	$T_{\{\bar{c}\bar{c}\}}^{(bb)} \rightarrow \bar{\Sigma}_c^- \Xi_b^0$	$-b_{12} V_{us}^*$
$T_{\{\bar{c}\bar{c}\}}^{(bb)} \rightarrow \bar{\Sigma}_c^- \Xi_b^-$	$-\frac{b_{12} V_{us}^*}{\sqrt{2}}$	$T_{\{\bar{c}\bar{c}\}}^{(bb)} \rightarrow \bar{\Xi}_c^- \Xi_b^-$	$\frac{b_{12} V_{ud}^*}{\sqrt{2}}$
$T_{\{\bar{c}\bar{c}\}}^{(bb)} \rightarrow \bar{\Sigma}_c^- \Sigma_b^0$	$\frac{b_{13} V_{ud}^*}{\sqrt{2}}$	$T_{\{\bar{c}\bar{c}\}}^{(bb)} \rightarrow \bar{\Sigma}_c^- \Xi_b^0$	$\frac{b_{13} V_{us}^*}{\sqrt{2}}$
$T_{\{\bar{c}\bar{c}\}}^{(bb)} \rightarrow \bar{\Sigma}_c^- \Sigma_b^-$	$\frac{b_{13} V_{ud}^*}{\sqrt{2}}$	$T_{\{\bar{c}\bar{c}\}}^{(bb)} \rightarrow \bar{\Sigma}_c^- \Xi_b^-$	$\frac{1}{2} b_{13} V_{us}^*$
$T_{\{\bar{c}\bar{c}\}}^{(bb)} \rightarrow \bar{\Xi}_c^- \Xi_b^-$	$\frac{1}{2} b_{13} V_{ud}^*$	$T_{\{\bar{c}\bar{c}\}}^{(bb)} \rightarrow \bar{\Xi}_c^- \Omega_b^-$	$\frac{b_{13} V_{us}^*}{\sqrt{2}}$
$T_{\{\bar{c}\bar{c}\}}^{(bb)} \rightarrow \bar{\Xi}_{cc}^- \Xi_{bc}^0$	$b_{14} V_{ud}^*$	$T_{\{\bar{c}\bar{c}\}}^{(bb)} \rightarrow \bar{\Xi}_{cc}^- \Omega_{bc}^0$	$b_{14} V_{us}^*$



**Table 6** Tetraquark  $T_{\{\bar{c}\bar{c}\}}^{\{bb\}}$  decays into three mesons induced by the charmless  $b \rightarrow d$  transition

Channel	Amplitude	Channel	Amplitude
$T_{\{\bar{c}\bar{c}\}}^{\{bb\}} \rightarrow \bar{D}^0 \pi^- B_c^-$	$d_3 - d_4 + 3d_5$	$T_{\{\bar{c}\bar{c}\}}^{\{bb\}} \rightarrow D^- \pi^0 B_c^-$	$\frac{-d_3+d_4+5d_5}{\sqrt{2}}$
$T_{\{\bar{c}\bar{c}\}}^{\{bb\}} \rightarrow D^- \eta B_c^-$	$\frac{d_3+3(d_4+d_5)}{\sqrt{6}}$	$T_{\{\bar{c}\bar{c}\}}^{\{bb\}} \rightarrow D_s^- K^0 B_c^-$	$d_3 + d_4 - d_5$
$T_{\{\bar{c}\bar{c}\}}^{\{bb\}} \rightarrow \bar{D}^0 D^- B^-$	$(d_1 + 6d_2)$	$T_{\{\bar{c}\bar{c}\}}^{\{bb\}} \rightarrow D^- D^- \bar{B}^0$	$2(d_1 - 2d_2)$
$T_{\{\bar{c}\bar{c}\}}^{\{bb\}} \rightarrow D^- D_s^- \bar{B}_s^0$	$(d_1 - 2d_2)$		

**Table 7** Tetraquark  $T_{\{\bar{c}\bar{c}\}}^{\{bb\}}$  decays into three mesons induced by the charmless  $b \rightarrow s$  transition

Channel	Amplitude	Channel	Amplitude
$T_{\{\bar{c}\bar{c}\}}^{\{bb\}} \rightarrow \bar{D}^0 K^- B_c^-$	$d_3 - d_4 + 3d_5$	$T_{\{\bar{c}\bar{c}\}}^{\{bb\}} \rightarrow D^- \bar{K}^0 B_c^-$	$d_3 + d_4 - d_5$
$T_{\{\bar{c}\bar{c}\}}^{\{bb\}} \rightarrow D_s^- \pi^0 B_c^-$	$\sqrt{2}(d_4 + 2d_5)$	$T_{\{\bar{c}\bar{c}\}}^{\{bb\}} \rightarrow D_s^- \eta B_c^-$	$-\sqrt{\frac{2}{3}}(d_3 - 3d_5)$
$T_{\{\bar{c}\bar{c}\}}^{\{bb\}} \rightarrow \bar{D}^0 D_s^- B^-$	$(d_1 + 6d_2)$	$T_{\{\bar{c}\bar{c}\}}^{\{bb\}} \rightarrow D^- D_s^- \bar{B}^0$	$(d_1 - 2d_2)$
$T_{\{\bar{c}\bar{c}\}}^{\{bb\}} \rightarrow D_s^- D_s^- \bar{B}_s^0$	$2(d_1 - 2d_2)$		

**Table 8** Tetraquark  $T_{\{\bar{c}\bar{c}\}}^{\{bb\}}$  decays into doubly charmed baryon plus singly bottom baryon induced by the charmless  $b \rightarrow d$  transition

Channel	Amplitude	Channel	Amplitude
$T_{\{\bar{c}\bar{c}\}}^{\{bb\}} \rightarrow \bar{\Xi}_{cc}^- \Lambda_b^0$	$2d_7 - d_6$	$T_{\{\bar{c}\bar{c}\}}^{\{bb\}} \rightarrow \bar{\Xi}_{cc}^- \Xi_b^-$	$d_6 + 2d_7$
$T_{\{\bar{c}\bar{c}\}}^{\{bb\}} \rightarrow \bar{\Xi}_{cc}^- \Sigma_b^0$	$\frac{d_8+6d_9}{\sqrt{2}}$	$T_{\{\bar{c}\bar{c}\}}^{\{bb\}} \rightarrow \bar{\Xi}_{cc}^- \Sigma_b^-$	$d_8 - 2d_9$
$T_{\{\bar{c}\bar{c}\}}^{\{bb\}} \rightarrow \bar{\Omega}_{cc}^- \Xi_b^{\prime-}$	$\frac{d_8-2d_9}{\sqrt{2}}$		

$$\begin{aligned} &+ d_5 T_{\{\bar{c}\bar{c}\}}^{\{bb\}} (H_{15})_k^{ij} M_i^k D_j \bar{B}_c, \\ \mathcal{H}_{eff} = & d_6 T_{\{\bar{c}\bar{c}\}}^{\{bb\}} (H_3)^i (F_{cc})^j (\bar{F}_{b3})_{[ij]} \\ &+ d_7 T_{\{\bar{c}\bar{c}\}}^{\{bb\}} (H_6)_k^{[ij]} (F_{cc})^k (\bar{F}_{b3})_{[ij]} \\ &+ d_8 T_{\{\bar{c}\bar{c}\}}^{\{bb\}} (H_3)^i (F_{cc})^j (\bar{F}_{b6})_{ij} \\ &+ d_9 T_{\{\bar{c}\bar{c}\}}^{\{bb\}} (H_{15})_k^{ij} (F_{cc})^k (\bar{F}_{b6})_{ij}. \end{aligned} \tag{27}$$

$$\begin{aligned} &\Gamma(T_{\{\bar{c}\bar{c}\}}^{\{bb\}} \rightarrow \bar{\Xi}_{cc}^- \Sigma_b^-) \\ &= 2\Gamma(T_{\{\bar{c}\bar{c}\}}^{\{bb\}} \rightarrow \bar{\Omega}_{cc}^- \Xi_b^-), \Gamma(T_{\{\bar{c}\bar{c}\}}^{\{bb\}} \rightarrow \bar{\Xi}_{cc}^- \Xi_b^{\prime-}) \\ &= \frac{1}{2}\Gamma(T_{\{\bar{c}\bar{c}\}}^{\{bb\}} \rightarrow \bar{\Omega}_{cc}^- \Omega_b^-). \end{aligned}$$

4.2.5  $\bar{c} \rightarrow \bar{q}_1 q_2 \bar{q}_3$  transition

In the three-body mesonic decays, the decay amplitudes are given in Table 6 for the transition  $b \rightarrow d$  and Table 7 for the transition  $b \rightarrow s$ . In the two-body baryonic decays, the corresponding amplitudes are listed in Table 8 for the transition  $b \rightarrow d$  and Table 9 for the transition  $b \rightarrow s$ . We obtain the relations of these decay widths given as

$$\begin{aligned} \Gamma(T_{\{\bar{c}\bar{c}\}}^{\{bb\}} \rightarrow \bar{B}^0 D^- D^-) &= 2\Gamma(T_{\{\bar{c}\bar{c}\}}^{\{bb\}} \\ &\rightarrow \bar{B}_s^0 D^- D_s^-), \Gamma(T_{\{\bar{c}\bar{c}\}}^{\{bb\}} \rightarrow \bar{B}^0 D^- D_s^-) \\ &= \frac{1}{2}\Gamma(T_{\{\bar{c}\bar{c}\}}^{\{bb\}} \rightarrow \bar{B}_s^0 D_s^- D_s^-), \end{aligned}$$

The effective Hamiltonian at the hadron-level for  $T_{\{\bar{c}\bar{c}\}}^{\{bb\}}$  producing two or three body final states can be constructed as follows,

$$\begin{aligned} \mathcal{H}_{eff} = & f_1 T_{\{\bar{c}\bar{c}\}}^{\{bb\}} (H_{15})_{[ij]}^k \bar{B}^i \bar{B}^j D_k, \\ \mathcal{H}_{eff} = & f_2 T_{\{\bar{c}\bar{c}\}}^{\{bb\}} (H_6)_{[ij]}^k M_i^k \bar{B}^j \bar{B}_c \\ &+ f_3 T_{\{\bar{c}\bar{c}\}}^{\{bb\}} (H_{15})_{[ij]}^k M_i^k \bar{B}^j \bar{B}_c, \\ \mathcal{H}_{eff} = & f_4 T_{\{\bar{c}\bar{c}\}}^{\{bb\}} (H_6)_{[ij]}^k (F_{c3})^{[ij]} (\bar{F}_{bb})_k \\ &+ f_5 T_{\{\bar{c}\bar{c}\}}^{\{bb\}} (H_{15})_{[ij]}^k (F_{c6})^{[ij]} (\bar{F}_{bb})_k. \end{aligned} \tag{28}$$

**Table 9** Tetraquark  $T_{\{\bar{c}\bar{c}\}}^{\{bb\}}$  decays into doubly charmed baryon plus singly bottom baryon induced by the charmless  $b \rightarrow s$  transition

Channel	Amplitude	Channel	Amplitude
$T_{\{\bar{c}\bar{c}\}}^{\{bb\}} \rightarrow \bar{\Xi}_{cc}^- \Xi_b^0$	$2d_7 - d_6$	$T_{\{\bar{c}\bar{c}\}}^{\{bb\}} \rightarrow \bar{\Xi}_{cc}^- \Xi_b^-$	$-d_6 - 2d_7$
$T_{\{\bar{c}\bar{c}\}}^{\{bb\}} \rightarrow \bar{\Xi}_{cc}^- \Xi_b^{\prime0}$	$\frac{d_8+6d_9}{\sqrt{2}}$	$T_{\{\bar{c}\bar{c}\}}^{\{bb\}} \rightarrow \bar{\Xi}_{cc}^- \Xi_b^{\prime-}$	$\frac{d_8-2d_9}{\sqrt{2}}$
$T_{\{\bar{c}\bar{c}\}}^{\{bb\}} \rightarrow \bar{\Omega}_{cc}^- \Omega_b^-$	$d_8 - 2d_9$		

**Table 10** Tetraquark  $T_{\{\bar{c}\bar{c}\}}^{(bb)}$  decays into three mesons for the transition  $\bar{c} \rightarrow \bar{q}_1 q_2 \bar{q}_3$ . In particular, the amplitudes are shown as Cabibbo allowed, singly Cabibbo suppressed, doubly suppressed respectively

Channel	Amplitude	Channel	Amplitude
$T_{\{\bar{c}\bar{c}\}}^{(bb)} \rightarrow B^- \bar{B}_s^0 D^-$	$2f_1$	$T_{\{\bar{c}\bar{c}\}}^{(bb)} \rightarrow B^- K^0 B_c^-$	$f_2 + f_3$
$T_{\{\bar{c}\bar{c}\}}^{(bb)} \rightarrow \bar{B}_s^0 \pi^- B_c^-$	$f_3 - f_2$	$T_{\{\bar{c}\bar{c}\}}^{(bb)} \rightarrow B^- \bar{B}_s^0 D_s^-$	$2f_1 sC$
$T_{\{\bar{c}\bar{c}\}}^{(bb)} \rightarrow B^- \bar{B}^0 D^-$	$-2f_1 sC$	$T_{\{\bar{c}\bar{c}\}}^{(bb)} \rightarrow B^- \eta B_c^-$	$-\sqrt{\frac{3}{2}}(f_2 + f_3) sC$
$T_{\{\bar{c}\bar{c}\}}^{(bb)} \rightarrow B^- \pi^0 B_c^-$	$\frac{(f_2 + f_3)sC}{\sqrt{2}}$	$T_{\{\bar{c}\bar{c}\}}^{(bb)} \rightarrow \bar{B}_s^0 K^- B_c^-$	$(f_3 - f_2) sC$
$T_{\{\bar{c}\bar{c}\}}^{(bb)} \rightarrow \bar{B}^0 \pi^- B_c^-$	$(f_2 - f_3) sC$	$T_{\{\bar{c}\bar{c}\}}^{(bb)} \rightarrow B^- \bar{K}^0 B_c^-$	$(f_2 + f_3) sC^2$
$T_{\{\bar{c}\bar{c}\}}^{(bb)} \rightarrow B^- \bar{B}^0 D_s^-$	$2f_1 sC^2$		
$T_{\{\bar{c}\bar{c}\}}^{(bb)} \rightarrow \bar{B}^0 K^- B_c^-$	$(f_2 - f_3)(-sC^2)$		

**Table 11** Tetraquark  $T_{\{\bar{c}\bar{c}\}}^{(bb)}$  decays into singly charmed baryon and doubly bottom baryon for the transition  $\bar{c} \rightarrow \bar{q}_1 q_2 \bar{q}_3$ . In particular, the amplitudes are shown as Cabibbo allowed, singly Cabibbo suppressed, doubly suppressed respectively

Channel	Amplitude	Channel	Amplitude
$T_{\{\bar{c}\bar{c}\}}^{(bb)} \rightarrow \bar{\Xi}_c^- \bar{\Xi}_{bb}^-$	$-2f_4$	$T_{\{\bar{c}\bar{c}\}}^{(bb)} \rightarrow \bar{\Xi}_c'^- \bar{\Xi}_{bb}^-$	$\sqrt{2}f_5$
$T_{\{\bar{c}\bar{c}\}}^{(bb)} \rightarrow \bar{\Lambda}_c^- \bar{\Xi}_{bb}^-$	$2f_4 sC$	$T_{\{\bar{c}\bar{c}\}}^{(bb)} \rightarrow \bar{\Xi}_c^- \Omega_{bb}^-$	$-2f_4 sC$
$T_{\{\bar{c}\bar{c}\}}^{(bb)} \rightarrow \bar{\Sigma}_c^- \bar{\Xi}_{bb}^-$	$-\sqrt{2}f_5 sC$	$T_{\{\bar{c}\bar{c}\}}^{(bb)} \rightarrow \bar{\Xi}_c'^- \Omega_{bb}^-$	$\sqrt{2}f_5 sC$
$T_{\{\bar{c}\bar{c}\}}^{(bb)} \rightarrow \bar{\Lambda}_c^- \Omega_{bb}^-$	$-2f_4 sC^2$	$T_{\{\bar{c}\bar{c}\}}^{(bb)} \rightarrow \bar{\Sigma}_c^- \Omega_{bb}^-$	$\sqrt{2}f_5 sC^2$

Here, it should be noticed that the above effective Hamiltonian can not lead to the two-body mesonic decays of  $T_{\{\bar{c}\bar{c}\}}^{(bb)}$ . Further more, the corresponding Feynman diagrams are given in Fig. 5. Expanding the Hamiltonian above and we can obtain the decay amplitudes shown in Tables 10 and 11. The relations between different decay widths are given as

$$\begin{aligned} \Gamma(T_{\{\bar{c}\bar{c}\}}^{(bb)} \rightarrow D^- B^- \bar{B}^0) &= \Gamma(T_{\{\bar{c}\bar{c}\}}^{(bb)} \rightarrow D_s^- B^- \bar{B}_s^0), \Gamma(T_{\{\bar{c}\bar{c}\}}^{(bb)} \rightarrow B^- \pi^0 B_c^-) \\ &= \frac{1}{3} \Gamma(T_{\{\bar{c}\bar{c}\}}^{(bb)} \rightarrow B^- \eta B_c^-), \\ \Gamma(T_{\{\bar{c}\bar{c}\}}^{(bb)} \rightarrow \bar{B}^0 \pi^- B_c^-) &= \Gamma(T_{\{\bar{c}\bar{c}\}}^{(bb)} \rightarrow \bar{B}_s^0 K^- B_c^-), \\ \Gamma(T_{\{\bar{c}\bar{c}\}}^{(bb)} \rightarrow \bar{\Lambda}_c^- \bar{\Xi}_{bb}^-) &= \Gamma(T_{\{\bar{c}\bar{c}\}}^{(bb)} \rightarrow \bar{\Xi}_c^- \Omega_{bb}^-), \Gamma(T_{\{\bar{c}\bar{c}\}}^{(bb)} \rightarrow \bar{\Sigma}_c^- \bar{\Xi}_{bb}^-) \\ &= \Gamma(T_{\{\bar{c}\bar{c}\}}^{(bb)} \rightarrow \bar{\Xi}_c'^- \Omega_{bb}^-). \end{aligned}$$

### 5 Golden decay channels

In this section, we will discuss the golden channels to reconstruct the  $T_{\{\bar{c}\bar{c}\}}^{(bb)}$ . Our previous classifications are mainly based on the CKM elements. In principle, the amplitudes of b-quark decay transitions such as  $b \rightarrow c \ell^- \bar{\nu}_\ell, b \rightarrow c \bar{s}$  and  $b \rightarrow c \bar{u}$  will receive the largest contribution as  $V_{cb} \sim 10^{-2}$ . For the  $\bar{c}$ -quark decay, the  $\bar{c} \rightarrow \bar{s} d \bar{u}$  and  $\bar{c} \rightarrow \bar{s} \ell^- \bar{\nu}_\ell$  transition has the largest decay widths as  $V_{cs}^* \sim 1$ . In our analysis, the final meson can be replaced by its corresponding counterpart

with the same quark constituent but with the different  $J^{PC}$  quantum numbers. For instance, one can replace a  $\bar{K}^0$  by  $\bar{K}^{*0}$ .

Following the criteria [65], we can obtain the golden decay channels in Table 12.

- Branching fractions: For  $\bar{c}$ -quark decays, one should choose the corresponding channels with the transition of  $\bar{c} \rightarrow \bar{s} d \bar{u}$  or  $\bar{c} \rightarrow \bar{s} \ell^- \bar{\nu}_\ell$ , while for  $b$ -quark decays, the process with the quark level transition  $b \rightarrow c \ell^- \bar{\nu}_\ell$  or  $b \rightarrow c \bar{s}$  or  $b \rightarrow c \bar{u}$  should be chosen.
- Detection efficiency: At hadron colliders like LHC, charged particles have higher rates to be detected than neutral states. So we will remove the channels with the final states  $\pi^0, \eta, \phi, n, \rho^\pm (\rightarrow \pi^\pm \pi^0), K^{*\pm} (\rightarrow K^\pm \pi^0)$  and  $\omega$ , but keep the modes with  $\pi^\pm, K^0 (\rightarrow \pi^+ \pi^-), \rho^0 (\rightarrow \pi^+ \pi^-)$ .

### 6 Conclusions

Although many charmonium-like and bottomonium-like states have been found on experimental side, our current knowledge on hadron exotics is still far from mature. The understanding on the hadron spectroscopy can be deepen by the study of exotic states of new categories. In this direction, the fully-heavy tetraquark  $T_{\{\bar{c}\bar{c}\}}^{(bb)}$  are of great interest. In this paper, we have discussed the lifetime and the weak decays. From our calculation, the lifetime of  $T_{\{\bar{c}\bar{c}\}}^{(bb)}$  is found about 0.1–0.3 ps. We have systematically discussed the possible weak decay modes, such as two- or three-body mesonic decays and two-body baryonic decays. Finally, we have collected the golden channels of  $T_{\{\bar{c}\bar{c}\}}^{(bb)}$  with the largest branching fraction and experimental detector efficiency. Certainly, the framework and analysis can be applicable to the states with the same quark structure  $bb\bar{c}\bar{c}$ . Our results for the lifetime and golden channels are helpful to search for the fully-heavy tetraquark in future experiments.

**Table 12** Cabibbo allowed  $T_{\{\bar{c}\bar{c}\}}^{(bb)}$   $\bar{c}$ -quark and b-quark decays respectively

$T_{\{\bar{c}\bar{c}\}}^{(bb)} \rightarrow \bar{B}_s^0 B_c^- l^- \bar{\nu}$	$T_{\{\bar{c}\bar{c}\}}^{(bb)} \rightarrow B^- \bar{B}_s^0 D^-$	$T_{\{\bar{c}\bar{c}\}}^{(bb)} \rightarrow B^- K^0 B_c^-$	$T_{\{\bar{c}\bar{c}\}}^{(bb)} \rightarrow \bar{B}_s^0 \pi^- B_c^-$
$T_{\{\bar{c}\bar{c}\}}^{(bb)} \rightarrow \bar{\Xi}_c^- \Xi_{bb}^-$	$T_{\{\bar{c}\bar{c}\}}^{(bb)} \rightarrow \bar{\Xi}_c'^- \Xi_{bb}^-$		
$T_{\{\bar{c}\bar{c}\}}^{(bb)} \rightarrow B_c l^- \bar{\nu}$	$T_{\{\bar{c}\bar{c}\}}^{(bb)} \rightarrow \pi^- B_c^-$	$T_{\{\bar{c}\bar{c}\}}^{(bb)} \rightarrow B^- D^-$	$T_{\{\bar{c}\bar{c}\}}^{(bb)} \rightarrow D_s^- B_c^-$
$T_{\{\bar{c}\bar{c}\}}^{(bb)} \rightarrow B_c J/\psi l^- \bar{\nu}$	$T_{\{\bar{c}\bar{c}\}}^{(bb)} \rightarrow \bar{D}^0 B^- l^- \bar{\nu}$	$T_{\{\bar{c}\bar{c}\}}^{(bb)} \rightarrow D^- \bar{B}^0 l^- \bar{\nu}$	$T_{\{\bar{c}\bar{c}\}}^{(bb)} \rightarrow D_s^- \bar{B}_s^0 l^- \bar{\nu}$
$T_{\{\bar{c}\bar{c}\}}^{(bb)} \rightarrow D_s^- B_c^- J/\psi$	$T_{\{\bar{c}\bar{c}\}}^{(bb)} \rightarrow \bar{D}^0 D_s^- B^-$	$T_{\{\bar{c}\bar{c}\}}^{(bb)} \rightarrow D^- D_s^- \bar{B}^0$	$T_{\{\bar{c}\bar{c}\}}^{(bb)} \rightarrow D_s^- D_s^- \bar{B}_s^0$
$T_{\{\bar{c}\bar{c}\}}^{(bb)} \rightarrow \bar{D}^0 B_c^- K^-$	$T_{\{\bar{c}\bar{c}\}}^{(bb)} \rightarrow D^- B_c^- \bar{K}^0$	$T_{\{\bar{c}\bar{c}\}}^{(bb)} \rightarrow \pi^- J/\psi B_c^-$	$T_{\{\bar{c}\bar{c}\}}^{(bb)} \rightarrow D^0 D^- B_c^-$
$T_{\{\bar{c}\bar{c}\}}^{(bb)} \rightarrow B^- D^- J/\psi$	$T_{\{\bar{c}\bar{c}\}}^{(bb)} \rightarrow B^- \bar{D}^0 \pi^-$	$T_{\{\bar{c}\bar{c}\}}^{(bb)} \rightarrow B^- D_s^- K^0$	$T_{\{\bar{c}\bar{c}\}}^{(bb)} \rightarrow \bar{B}^0 D^- \pi^-$
$T_{\{\bar{c}\bar{c}\}}^{(bb)} \rightarrow \bar{B}_s^0 D^- K^-$	$T_{\{\bar{c}\bar{c}\}}^{(bb)} \rightarrow \bar{B}_s^0 D_s^- \pi^-$	$T_{\{\bar{c}\bar{c}\}}^{(bb)} \rightarrow K^0 K^- B_c^-$	$T_{\{\bar{c}\bar{c}\}}^{(bb)} \rightarrow \bar{D}^0 D_s^- B_c^-$
$T_{\{\bar{c}\bar{c}\}}^{(bb)} \rightarrow \bar{\Xi}_{cc}^- \Xi_b^0$	$T_{\{\bar{c}\bar{c}\}}^{(bb)} \rightarrow \bar{\Xi}_{cc}^- \Xi_b^-$	$T_{\{\bar{c}\bar{c}\}}^{(bb)} \rightarrow \bar{\Xi}_{cc}^- \Xi_b'^0$	$T_{\{\bar{c}\bar{c}\}}^{(bb)} \rightarrow \bar{\Xi}_{cc}^- \Xi_b'^-$
$T_{\{\bar{c}\bar{c}\}}^{(bb)} \rightarrow \bar{\Omega}_{cc}^- \Omega_b^-$	$T_{\{\bar{c}\bar{c}\}}^{(bb)} \rightarrow \Omega_{bc}^- \bar{\Omega}_{ccc}^-$	$T_{\{\bar{c}\bar{c}\}}^{(bb)} \rightarrow \bar{\Xi}_{cc}^- \Xi_b^-$	$T_{\{\bar{c}\bar{c}\}}^{(bb)} \rightarrow \bar{\Lambda}_c^- \Sigma_b^-$
$T_{\{\bar{c}\bar{c}\}}^{(bb)} \rightarrow \bar{\Sigma}_c^- \Lambda_b^0$	$T_{\{\bar{c}\bar{c}\}}^{(bb)} \rightarrow \bar{\Xi}_c^- \Xi_b'^-$	$T_{\{\bar{c}\bar{c}\}}^{(bb)} \rightarrow \bar{\Xi}_c^- \Xi_b^-$	$T_{\{\bar{c}\bar{c}\}}^{(bb)} \rightarrow \bar{\Sigma}_c^- \Sigma_b^0$
$T_{\{\bar{c}\bar{c}\}}^{(bb)} \rightarrow \bar{\Sigma}_c^- \Sigma_b^-$	$T_{\{\bar{c}\bar{c}\}}^{(bb)} \rightarrow \bar{\Xi}_c'^- \Xi_b'^-$	$T_{\{\bar{c}\bar{c}\}}^{(bb)} \rightarrow \bar{\Xi}_{cc}^- \Xi_b^0$	$T_{\{\bar{c}\bar{c}\}}^{(bb)} \rightarrow \Xi_b^- \bar{\Omega}_{ccc}^-$
$T_{\{\bar{c}\bar{c}\}}^{(bb)} \rightarrow \Xi_b'^0 \bar{\Omega}_{ccc}^-$			

**Acknowledgements** This work is supported in part by National Natural Science Foundation of China under Grant Nos. 11575110, 11655002, 11675091, 11735010, and 11835015, by Natural Science Foundation of Shanghai under Grant No. 15DZ2272100, by Key Laboratory for Particle Physics, Astrophysics and Cosmology, Ministry of Education.

**Data Availability Statement** This manuscript has no associated data or the data will not be deposited. [Authors' comment: This is a theoretical study and no experimental data has been listed.]

**Open Access** This article is distributed under the terms of the Creative Commons Attribution 4.0 International License (<http://creativecommons.org/licenses/by/4.0/>), which permits unrestricted use, distribution, and reproduction in any medium, provided you give appropriate credit to the original author(s) and the source, provide a link to the Creative Commons license, and indicate if changes were made. Funded by SCOAP<sup>3</sup>.

**References**

1. S.K. Choi et al. [Belle Collaboration], Phys. Rev. Lett. **91**, 262001 (2003). <https://doi.org/10.1103/PhysRevLett.91.262001>. arXiv:hep-ex/0309032
2. A. Bondar et al. [Belle Collaboration], Phys. Rev. Lett. **108**, 122001 (2012). <https://doi.org/10.1103/PhysRevLett.108.122001>. arXiv:1110.2251 [hep-ex]
3. M. Ablikim et al. [BESIII Collaboration], Phys. Rev. Lett. **110**, 252001 (2013). <https://doi.org/10.1103/PhysRevLett.110.252001>. arXiv:1303.5949 [hep-ex]
4. M. Ablikim et al. [BESIII Collaboration], Phys. Rev. Lett. **112**(13), 132001 (2014). <https://doi.org/10.1103/PhysRevLett.112.132001>. arXiv:1308.2760 [hep-ex]
5. S.K. Choi et al. [Belle Collaboration], Phys. Rev. Lett. **100**, 142001 (2008). <https://doi.org/10.1103/PhysRevLett.100.142001>. arXiv:0708.1790 [hep-ex]
6. R. Aaij et al. [LHCb Collaboration], Phys. Rev. Lett. **115**, 072001 (2015). <https://doi.org/10.1103/PhysRevLett.115.072001>. arXiv:1507.03414 [hep-ex]

7. M. Tanabashi et al., Particle data group. Phys. Rev. D **98**(3), 030001 (2018). <https://doi.org/10.1103/PhysRevD.98.030001>
8. F.K. Guo, C. Hidalgo-Duque, J. Nieves, M.P. Valderrama, Phys. Rev. D **88**, 054007 (2013). <https://doi.org/10.1103/PhysRevD.88.054007>. arXiv:1303.6608 [hep-ph]
9. M. Cleven, Q. Wang, F.K. Guo, C. Hanhart, U.G. Meissner, Q. Zhao, Phys. Rev. D **87**(7), 074006 (2013). <https://doi.org/10.1103/PhysRevD.87.074006>. arXiv:1301.6461 [hep-ph]
10. F.K. Guo, U.G. Meißner, W. Wang, Commun. Theor. Phys. **61**, 354 (2014). <https://doi.org/10.1088/0253-6102/61/3/14>. arXiv:1308.0193 [hep-ph]
11. X.H. Liu, G. Li, Eur. Phys. J. C **76**(8), 455 (2016). <https://doi.org/10.1140/epjc/s10052-016-4308-1>. arXiv:1603.00708 [hep-ph]
12. G. Li, X.H. Liu, Z. Zhou, Phys. Rev. D **90**(5), 054006 (2014). <https://doi.org/10.1103/PhysRevD.90.054006>. arXiv:1409.0754 [hep-ph]
13. G. Li, Eur. Phys. J. C **73**(11), 2621 (2013). <https://doi.org/10.1140/epjc/s10052-013-2621-5>. arXiv:1304.4458 [hep-ph]
14. F.K. Guo, U.G. Meißner, W. Wang, Z. Yang, Eur. Phys. J. C **74**(9), 3063 (2014). <https://doi.org/10.1140/epjc/s10052-014-3063-4>. arXiv:1402.6236 [hep-ph]
15. F.K. Guo, U.G. Meißner, W. Wang, Z. Yang, JHEP **1405**, 138 (2014). [https://doi.org/10.1007/JHEP05\(2014\)138](https://doi.org/10.1007/JHEP05(2014)138). arXiv:1403.4032 [hep-ph]
16. F.K. Guo, C. Hanhart, Q. Wang, Q. Zhao, Phys. Rev. D **91**(5), 051504 (2015). <https://doi.org/10.1103/PhysRevD.91.051504>. arXiv:1411.5584 [hep-ph]
17. Y.H. Chen, M. Cleven, J.T. Daub, F.K. Guo, C. Hanhart, B. Kubis, U.G. Meißner, B.S. Zou, Phys. Rev. D **95**(3), 034022 (2017). <https://doi.org/10.1103/PhysRevD.95.034022>. arXiv:1611.00913 [hep-ph]
18. Q. Wang, M. Cleven, F.K. Guo, C. Hanhart, U.G. Meißner, X.G. Wu, Q. Zhao, Phys. Rev. D **89**(3), 034001 (2014). <https://doi.org/10.1103/PhysRevD.89.034001>. arXiv:1309.4303 [hep-ph]
19. G. Li, F.I. Shao, C.W. Zhao, O. Zhao, Phys. Rev. D **87**(3), 034020 (2013). <https://doi.org/10.1103/PhysRevD.87.034020>. arXiv:1212.3784 [hep-ph]
20. G. Li, W. Wang, Phys. Lett. B **733**, 100 (2014). <https://doi.org/10.1016/j.physletb.2014.04.029>. arXiv:1402.6463 [hep-ph]
21. M. Albaladejo, F.K. Guo, C. Hanhart, U.G. Meißner, J. Nieves, A. Nogga, Z. Yang, Chin. Phys. C **41**(12), 121001 (2017). <https://doi.org/10.1088/1674-7480/41/12/121001>

- [org/10.1088/1674-1137/41/12/121001](https://doi.org/10.1088/1674-1137/41/12/121001). arXiv:1709.09101 [hep-ph]
22. X.H. Liu, G. Li, Phys. Rev. D **88**, 014013 (2013). <https://doi.org/10.1103/PhysRevD.88.014013>. arXiv:1306.1384 [hep-ph]
  23. F.K. Guo, C. Hanhart, U.G. Meißner, Q. Wang, Q. Zhao, Phys. Lett. B **725**, 127 (2013). <https://doi.org/10.1016/j.physletb.2013.06.053>. arXiv:1306.3096 [hep-ph]
  24. M.B. Voloshin, Phys. Rev. D **87**(7), 074011 (2013). <https://doi.org/10.1103/PhysRevD.87.074011>. arXiv:1301.5068 [hep-ph]
  25. M.B. Voloshin, Phys. Rev. D **84**, 031502 (2011). <https://doi.org/10.1103/PhysRevD.84.031502>. arXiv:1105.5829 [hep-ph]
  26. D.Y. Chen, X. Liu, Phys. Rev. D **84**, 094003 (2011). <https://doi.org/10.1103/PhysRevD.84.094003>. arXiv:1106.3798 [hep-ph]
  27. G. Li, X.H. Liu, Phys. Rev. D **88**(9), 094008 (2013). <https://doi.org/10.1103/PhysRevD.88.094008>. arXiv:1307.2622 [hep-ph]
  28. D.Y. Chen, X. Liu, T. Matsuki, Phys. Rev. D **84**, 074032 (2011). <https://doi.org/10.1103/PhysRevD.84.074032>. arXiv:1108.4458 [hep-ph]
  29. D.Y. Chen, X. Liu, T. Matsuki, Chin. Phys. C **38**, 053102 (2014). <https://doi.org/10.1088/1674-1137/38/5/053102>. arXiv:1208.2411 [hep-ph]
  30. A.E. Bondar, A. Garmash, A.I. Milstein, R. Mizuk, M.B. Voloshin, Phys. Rev. D **84**, 054010 (2011). <https://doi.org/10.1103/PhysRevD.84.054010>. arXiv:1105.4473 [hep-ph]
  31. G. Li, Z. Zhou, Phys. Rev. D **91**(3), 034020 (2015). <https://doi.org/10.1103/PhysRevD.91.034020>. arXiv:1502.02936 [hep-ph]
  32. D.Y. Chen, X. Liu, T. Matsuki, Phys. Rev. D **88**(1), 014034 (2013). <https://doi.org/10.1103/PhysRevD.88.014034>. arXiv:1306.2080 [hep-ph]
  33. Q. Wu, G. Li, F. Shao, R. Wang, Phys. Rev. D **94**(1), 014015 (2016). <https://doi.org/10.1103/PhysRevD.94.014015>
  34. A. Esposito, A. Pilloni, A.D. Polosa, Phys. Rep. **668**, 1 (2016). <https://doi.org/10.1016/j.physrep.2016.11.002>. arXiv:1611.07920 [hep-ph]
  35. Q. Wu, D.Y. Chen, X.J. Fan, G. Li, Eur. Phys. J. C **79**(3), 265 (2019). <https://doi.org/10.1140/epjc/s10052-019-6784-6>. arXiv:1902.05737 [hep-ph]
  36. Y. Zhang, G. Li, Phys. Rev. D **97**(1), 014018 (2018). <https://doi.org/10.1103/PhysRevD.97.014018>. arXiv:1801.03582 [hep-ph]
  37. Q. Wu, G. Li, F. Shao, Q. Wang, R. Wang, Y. Zhang, Y. Zheng, Adv. High Energy Phys. **2016**, 3729050 (2016). <https://doi.org/10.1155/2016/3729050>. arXiv:1606.05118 [hep-ph]
  38. Y. Bai, S. Lu, J. Osborne, arXiv:1612.00012 [hep-ph]
  39. M. Karliner, S. Nussinov, J.L. Rosner, Phys. Rev. D **95**(3), 034011 (2017). <https://doi.org/10.1103/PhysRevD.95.034011>. arXiv:1611.00348 [hep-ph]
  40. J. Wu, Y.R. Liu, K. Chen, X. Liu, S.L. Zhu, Phys. Rev. D **97**(9), 094015 (2018). <https://doi.org/10.1103/PhysRevD.97.094015>. arXiv:1605.01134 [hep-ph]
  41. M.N. Anwar, J. Ferretti, F.K. Guo, E. Santopinto, B.S. Zou, Eur. Phys. J. C **78**(8), 647 (2018). <https://doi.org/10.1140/epjc/s10052-018-6073-9>. arXiv:1710.02540 [hep-ph]
  42. W. Chen, H.X. Chen, X. Liu, T.G. Steele, S.L. Zhu, Phys. Lett. B **773**, 247 (2017). <https://doi.org/10.1016/j.physletb.2017.08.034>. arXiv:1605.01647 [hep-ph]
  43. Z.G. Wang, Eur. Phys. J. C **77**(7), 432 (2017). <https://doi.org/10.1140/epjc/s10052-017-4997-0>. arXiv:1701.04285 [hep-ph]
  44. M.S. Liu, Q.F. Lu, X.H. Zhong, Q. Zhao, arXiv:1901.02564 [hep-ph]
  45. R.L. Jaffe, F. Wilczek, Phys. Rev. Lett. **91**, 232003 (2003). <https://doi.org/10.1103/PhysRevLett.91.232003>. arXiv:hep-ph/0307341
  46. M.J. Savage, M.B. Wise, Phys. Rev. D **39**, 3346 (1989). <https://doi.org/10.1103/PhysRevD.40.3127>. Erratum: [Phys. Rev. D **40** (1989) 3127]. <https://doi.org/10.1103/PhysRevD.39.3346>
  47. M. Gronau, O.F. Hernandez, D. London, J.L. Rosner, Phys. Rev. D **52**, 6356 (1995). <https://doi.org/10.1103/PhysRevD.52.6356>. arXiv:hep-ph/9504326
  48. X.G. He, Eur. Phys. J. C **9**, 443 (1999). <https://doi.org/10.1007/s100529900064>. arXiv:hep-ph/9810397
  49. C.W. Chiang, M. Gronau, J.L. Rosner, D.A. Suprun, Phys. Rev. D **70**, 034020 (2004). <https://doi.org/10.1103/PhysRevD.70.034020>. arXiv:hep-ph/0404073
  50. Y. Li, C.D. Lu, W. Wang, Phys. Rev. D **77**, 054001 (2008). <https://doi.org/10.1103/PhysRevD.77.054001>. arXiv:0711.0497 [hep-ph]
  51. W. Wang, C.D. Lu, Phys. Rev. D **82**, 034016 (2010). <https://doi.org/10.1103/PhysRevD.82.034016>. arXiv:0910.0613 [hep-ph]
  52. H.Y. Cheng, S. Oh, JHEP **1109**, 024 (2011). [https://doi.org/10.1007/JHEP09\(2011\)024](https://doi.org/10.1007/JHEP09(2011)024). arXiv:1104.4144 [hep-ph]
  53. Y.K. Hsiao, C.F. Chang, X.G. He, Phys. Rev. D **93**(11), 114002 (2016). <https://doi.org/10.1103/PhysRevD.93.114002>. arXiv:1512.09223 [hep-ph]
  54. C.D.L.W. Wang, F.S. Yu, Phys. Rev. D **93**(5), 056008 (2016). <https://doi.org/10.1103/PhysRevD.93.056008>. arXiv:1601.04241 [hep-ph]
  55. X.G. He, W. Wang, R.L. Zhu, J. Phys. G **44**(1), 014003 (2017). <https://doi.org/10.1088/0954-3899/44/1/014003>. arXiv:1606.00097 [hep-ph]
  56. W. Wang, R.L. Zhu, Phys. Rev. D **96**(1), 014024 (2017). <https://doi.org/10.1103/PhysRevD.96.014024>. arXiv:1704.00179 [hep-ph]
  57. W. Wang, F.S. Yu, Z.X. Zhao, Eur. Phys. J. C **77**(11), 781 (2017). <https://doi.org/10.1140/epjc/s10052-017-5360-1>. arXiv:1707.02834 [hep-ph]
  58. W. Wang, Z.P. Xing, J. Xu, Eur. Phys. J. C **77**(11), 800 (2017). <https://doi.org/10.1140/epjc/s10052-017-5363-y>. arXiv:1707.06570 [hep-ph]
  59. Y.J. Shi, W. Wang, Y. Xing, J. Xu, Eur. Phys. J. C **78**(1), 56 (2018). <https://doi.org/10.1140/epjc/s10052-018-5532-7>. arXiv:1712.03830 [hep-ph]
  60. W. Wang, J. Xu, Phys. Rev. D **97**(9), 093007 (2018). <https://doi.org/10.1103/PhysRevD.97.093007>. arXiv:1803.01476 [hep-ph]
  61. X.G. He, W. Wang, Chin. Phys. C **42**(10), 103108 (2018). <https://doi.org/10.1088/1674-1137/42/10/103108>. arXiv:1803.04227 [hep-ph]
  62. Y. Xing, R. Zhu, Phys. Rev. D **98**(5), 053005 (2018). <https://doi.org/10.1103/PhysRevD.98.053005>. arXiv:1806.01659 [hep-ph]
  63. A. Lenz, Int. J. Mod. Phys. A **30**(10), 1543005 (2015). <https://doi.org/10.1142/S0217751X15430058>. arXiv:1405.3601 [hep-ph]
  64. A. Ali, Q. Qin, W. Wang, Phys. Lett. B **785**, 605 (2018). <https://doi.org/10.1016/j.physletb.2018.09.018>. arXiv:1806.09288 [hep-ph]
  65. G. Li, X.F. Wang, Y. Xing, Eur. Phys. J. C **79**(3), 210 (2019). <https://doi.org/10.1140/epjc/s10052-019-6729-0>. arXiv:1811.03849 [hep-ph]