CONDENSED
MATTER

New Type of “Dark” States in the Spectrum of Radiative Magnon Polarons

S. V. Tarasenko^{a,*} and V. G. Shavrov^b

^a Donetsk Institute for Physics and Engineering, Donetsk, 83114 Ukraine

^b Kotelnikov Institute of Radio Engineering and Electronics, Russian Academy of Sciences, Moscow, 125009 Russia

*e-mail: s.v.tarasenko@mail.ru

Received November 21, 2021; revised November 21, 2021; accepted December 3, 2021

The appearance of new types of bound (“dark”) states in the continuous spectrum of shear phonons of the radiation field of leaky magnon polarons in an acoustically open “easy-axis antiferromagnet–superconductor” sandwich structure can be determined by the relative orientation of the plane of incidence of a transverse elastic wave and the equilibrium antiferromagnetism vector in the interface plane between the media. The effect is based on the elastic dipole mechanism of the formation of magneto-acoustic birefringence with a change of the refraction cavity induced by the symmetric or antisymmetric Dzyaloshinskii interaction.

DOI: 10.1134/S0021364022020102

Recent intensive studies in spintronics were significantly stimulated by prospects of using spin rather than charge currents as a possible new physical foundation for a wide set of high-speed and energy-efficient devices for storage and processing of information flows [1, 2]. In particular, it was shown that the magnetoelastic coupling based on the spin–orbit, dipole–dipole, and exchange mechanisms [3] can be of crucial importance in the spin dynamics of magnetic heterostructures [4, 5]. As a result, treating magnons as specific electronic excitations, it is important to study magnon polarons, which are hybrid magnon–phonon states appearing because of the coherent interaction between vibrations of the spin and elastic subsystems of a real magnetic medium [6, 7]. Researchers actively analyze their role in the continuously expanding circle of physical phenomena, including effects of the Bragg reflection of waves (an elastic wave from a spin one and vice versa), transfer of the angular momentum of a propagating elastic wave, direct and inverse spin Seebeck effects, processes of thermalization of nonequilibrium magnon gas, and Bose–Einstein condensation of magnons [8]. Although radiative (“leaky”) magnon polarons, which are formed in acoustically open multilayer heterostructures, are of particular interest for applications of magnonics, the features of the spectrum of their phonon radiation field (in contrast to nonmagnetic heterostructures [9, 10]) are still almost unstudied. At the same time, similar anomalies for the case of a radiative phonon field in micro- and optophotonics are currently under active investigation [11–13]. One of the most demonstrative examples in this field is the study of conditions for the appearance

of bound states in the continuum for the resonance field of open resonance structures and accompanying dynamic effects [14]. In particular, a new approach to obtain high- Q -factor resonances in individual sub-wavelength cavities in the “supercavity” mode was proposed in [13] with the use of features of the formation of bound states in the continuum that were first mentioned in [15]. According to [15], bound states in the continuum can be due to the destructive interference of the radiation field responsible for both radiative damping and the interaction between frequency-degenerate cavities if their number is larger than the number of open radiation channels. In particular, as shown in [16], such “interference” bound states in the continuum can exist in optically transparent and anisotropic layered heterostructures if birefringence occurs in a layer supporting the formation of a bulk emitted electromagnetic wave in the studied optical configuration. This can ensure the degeneracy of frequencies of radiative modes of open cavities necessary for the formation of dark states in the continuum through the mechanism proposed in [15]. However, this means that a similar type of bound states in the continuum is possible for an acoustically open isotropic elastic layer if the emitted bulk elastic wave is polarized in the plane of incidence because acoustic birefringence is also possible in this case [14, 17]. According to [18–23], the formation of additional types of interference bound states in the continuous spectrum of the phonon radiation field of the magnetic layer can also be expected in the acoustically open magnetic medium layer with the magnetoelastic coupling. First, one should note the region of the

spectrum of magneto-acoustic (MA) waves that corresponds to radiative magnon polarons with the elastic displacement vector \mathbf{u} orthogonal to the plane of incidence of the wave (SH polarization). A necessary condition of their appearance is the possibility of occurrence of the MA birefringence (birefraction) for the elastic bulk shear wave at the interface between the magnetic and nonmagnetic media because of various variants of hybridization of the magnetoelastic, magnetic dipole, and inhomogeneous exchange interactions in the magnetic medium. Conditions for the formation of interference bound states in the continuous spectrum of radiative bulk magnon polarons with the elastic displacement vector $\mathbf{u} \parallel \mathbf{a}$ (where \mathbf{a} is the normal to the place of incidence of the wave) that propagate in an acoustically open layer of a uniformly magnetized compensated antiferromagnetic (AFM) material owing to the pairwise combination of some aforementioned indirect spin–spin interaction mechanisms were studied in [24, 25]. A two-sublattice model of the uniaxial AFM material in the collinear phase with an easy magnetic axis directed along the normal \mathbf{q} to the interface between the media was considered in [24, 25] as a magnetic medium. It was assumed that the magnetoelastic and elastic properties of the media are isotropic. The geometry of the problem is shown in Fig. 1a, where \mathbf{a} is the unit normal vector to the plane of incidence and $\mathbf{b} = [\mathbf{q}\mathbf{a}]$. The structure of the section of the wave vector surface by the plane of incidence in the case of the elastic dipole mechanism of the formation of the MA birefringence effect is shown in Fig. 1b. In [25], $\mathbf{k} \in (Y, Z)$, the equilibrium antiferromagnetism vector \mathbf{l}_0 is $\mathbf{l}_0 \parallel \mathbf{q} \parallel OZ$, and $\mathbf{u} \parallel \mathbf{a} \parallel OX$. However, the results were obtained in [24, 25] under assumptions significant for the aims of our work. First, both radiative modes involved in the formation of the “dark” state in the spectrum of magnon polarons with $\mathbf{u} \parallel \mathbf{a}$ are forward waves in dispersion properties irrespective of the mechanism of formation of bound states in the continuum in all cases considered in [24, 25]. Second, conditions for the formation of bound states in the continuum caused by the hybridization of the magnetoelastic and magnetic dipole interactions were determined only for the case where MA birefringence without change of the refraction cavity is possible at the interface between the magnetic and nonmagnetic media (see Fig. 1b). Third, the MA configuration (see Fig. 1a) chosen in [24, 25] is cylindrically symmetric with respect to the principal axis of the AFM material $\mathbf{l}_0 \parallel \mathbf{q} \parallel OZ$; consequently, the results were qualitatively independent of the presence of the symmetric or antisymmetric Dzyaloshinskii interaction in the considered uniaxial AFM material (and, therefore, of the corresponding structure of the piezomagnetic interaction [26]). At the same time, the authors of [16] showed for the first time that new types of bound states in the continuous radiation spectrum of an electromagnetically open layer of the optically uniaxial medium can be formed owing to the hybridization of

TM and TE wave if the optical axis of the medium is at the interface between the media rather than in the plane of incidence of the wave. Thus, according to the above review of the literature, it has not yet been studied whether new types of bound states in the continuous spectrum of radiative magnon polarons, which are induced by the elastic dipole interaction, can be formed by means of the choice of a MA configuration for an acoustically open layer of the uniaxial AFM material in the collinear phase with $\mathbf{l}_0 \perp \mathbf{q}$.

The aim of this work is to determine conditions under which the hybridization of the magnetic dipole and magnetoelastic interactions can lead to the appearance of new types of bound states in the spectrum of leaky magnon polarons with $\mathbf{u} \parallel \mathbf{a}$ propagating along an acoustically open layer of a uniaxial AFM material with the easy magnetic axis parallel to the interface between the media for particular cases.

We consider a spatially uniform magnetic layer with the thickness $2d$ located in an infinite elastically isotropic magnetic medium with the free energy density [27]

$$\tilde{F} = \frac{\tilde{\lambda}}{2} \tilde{u}_{ii}^2 + \tilde{\mu} \tilde{u}_{ik}^2, \quad (1)$$

where the tilde means the characteristics of the nonmagnetic medium such as the Lamé parameters λ and μ and the elastic strain tensor u_{ik} . As an example of the magnetic medium, we consider the two-sublattice model ($|\mathbf{M}_1| = |\mathbf{M}_2| = M_0$, M_0 is the saturation magnetization of the sublattices \mathbf{M}_1 and \mathbf{M}_2) of an exchange-collinear uniaxial (OZ axis) AFM material. To simplify the calculations, we assume, as in [24, 25], that its elastic and magnetoelastic (constant γ) properties are isotropic. Taking into account second-order invariants, the free energy density of such AFM material can be expressed in terms of ferromagnetism, $\mathbf{m} = (\mathbf{M}_1 + \mathbf{M}_2)/2M_0$, and antiferromagnetism, $\mathbf{l} = (\mathbf{M}_1 - \mathbf{M}_2)/2M_0$, vectors as [23, 26]

$$F = M_0^2 \times \left(\frac{\delta}{2} \mathbf{m}^2 - \frac{b}{2} l_z^2 + \gamma l_i l_k u_{ik} + d(m_x l_y + \tau m_y l_x) - 2\mathbf{m}\mathbf{h} \right) + \frac{\lambda}{2} u_{ii}^2 + \mu u_{ik}^2. \quad (2)$$

Here, δ is the intersublattice exchange constant, $b > 0$ is the easy-axis magnetic anisotropy constant, \mathbf{h} is the reduced magnetic field, and d is the Dzyaloshinskii coupling constant with the antisymmetric ($\tau = -1$ in Eq. (2)) or symmetric ($\tau = 1$ in Eq. (2)) structure. As known, the magnetoelastic dynamics of the considered model of the AFM material specified by Eq. (2) is described by a closed system of equations consisting of Landau–Lifshitz equations for vectors \mathbf{m} and \mathbf{l} , the basic equation of solid mechanics, and magnetostatic equations [18–20]. If

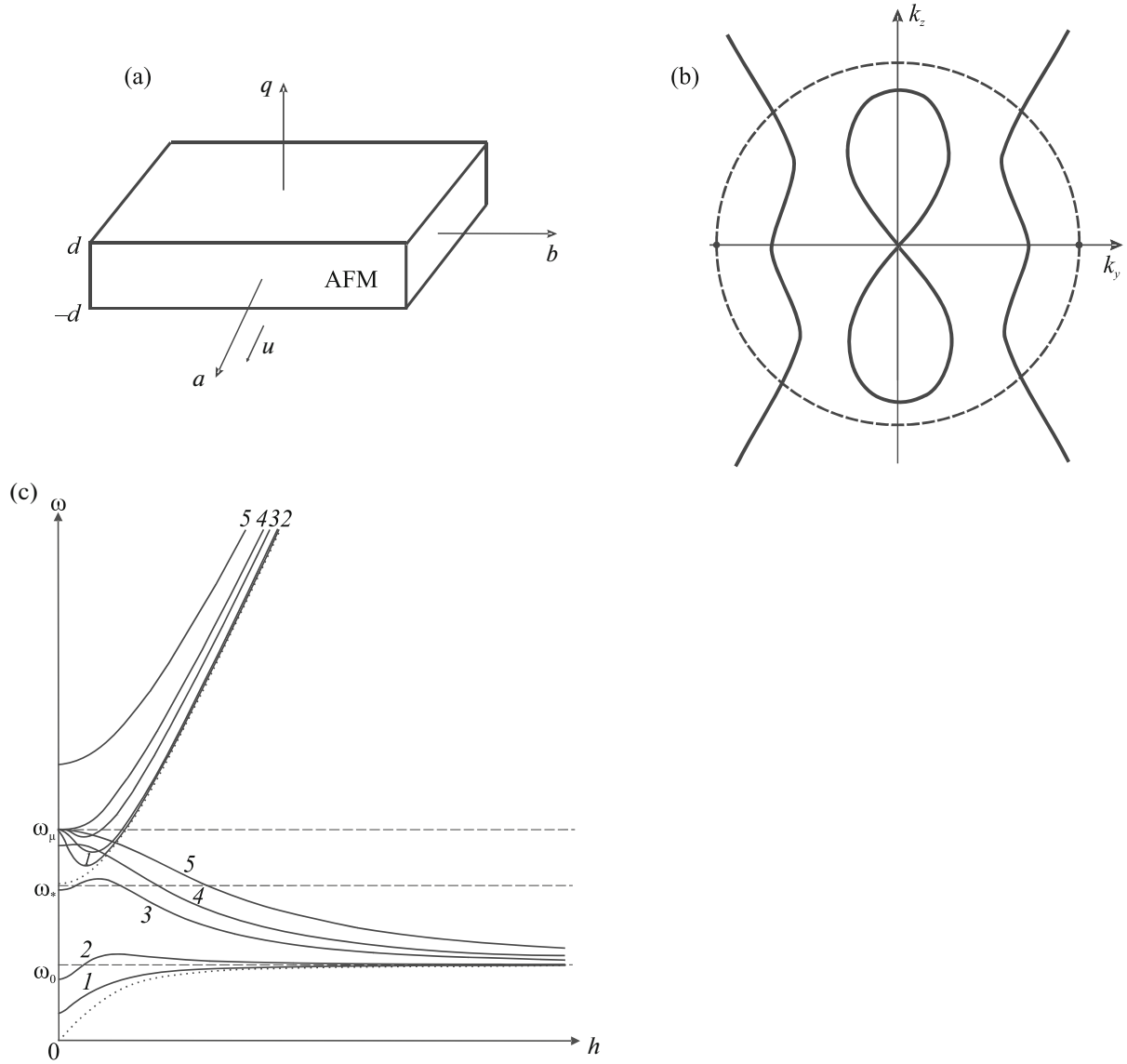

Fig. 1. (a) Geometry of the problem. (b) Qualitative form of the section of the wave vector surface of the shear elastic wave by the plane of incidence in the (dashed lines) nonmagnetic medium and (solid lines) infinite easy-axis antiferromagnet specified by Eq. (2) with $\tau = 1$ and -1 in Eq. (5) in the elastic dipole mechanism of the magneto-acoustic birefringence ($\tau = 0$ in [25]). The dashed circle is the section of the wave vector surface for the nonmagnetic medium described by Eq. (1). (c) Degeneracy points (bound states in the continuum) in the spectrum of radiative bulk magnon polarons specified by Eqs. (15) and (16). Lines 1–5 correspond to $\kappa_v^2 = 0.001, 0.01, 0.03, 0.05,$ and 0.1 in Eq. (15), respectively; $\omega_0^2 = 0.3\omega_{me}^2, \varepsilon = 0.8$.

the normal to the interface between the AFM and nonmagnetic media is $\mathbf{q} \parallel OY$, the corresponding coupling equations at $\mathbf{l}_0 \parallel OZ$ ($|\mathbf{l}_0| = 1$) and $\tau = -1$ and 1 for the plane elastic wave with the elastic displacement vector $\mathbf{u} \parallel OX$, frequency ω , and wave vector $\mathbf{k} \in (Y, Z)$ propagating in the AFM material specified by Eq. (2) can be represented in the form

$$\begin{aligned} \sigma_{zx} &= \mu c_{\perp} \frac{\partial u_x}{\partial z} + (\tau\beta - i\beta_*)h_y, & \sigma_{xy} &= \mu \frac{\partial u_x}{\partial y}, \\ B_y &= \mu_{\perp} h_y - 4\pi(\tau\beta + i\beta_*) \frac{\partial u_x}{\partial z}, & B_z &= h_z, \end{aligned} \quad (3)$$

$$\begin{cases} c_{\perp} \equiv \frac{\omega_*^2 - \omega_{me}^2 - \omega^2}{\omega_*^2 - \omega^2}, & \omega_{me}^2 \equiv \frac{g^2 M_0^2 \delta \gamma^2}{\mu}, \\ \omega_*^2 \equiv \omega_0^2 + \omega_{me}^2, \\ \beta \equiv \frac{g^2 M_0^2 \gamma d}{\omega_*^2 - \omega^2}, & \beta_* \equiv \frac{g M_0 \gamma \omega}{\omega_*^2 - \omega^2}; \\ \mu_{\perp} \equiv 1 + \frac{\varepsilon \omega_*^2}{\omega_*^2 - \omega^2}. \end{cases} \quad (4)$$

Here, $\bar{\sigma}$ is the elastic stress tensor, \mathbf{B} is the magnetic flux density, μc_{\perp} is the effective elastic modulus, β and β_* are the effective piezomagnetic moduli, μ_{\perp} is the permeability tensor component, ω_0 is the activation energy of the spin wave induced by uniaxial anisotropy, ω_{me} is the magnetoelastic gap, $\varepsilon \equiv 16\pi/\delta$, and ω_* is the frequency of the antiferromagnetic resonance [28]. The calculation with Eqs. (3) and (4) for the considered model of the AFM material shows that the relation of the character of the localization of the shear wave with the frequency ω and longitudinal wavenumber h , $\mathbf{u} \parallel OX$, $\mathbf{l}_0 \parallel OZ$, $\mathbf{k} \in (Y, Z)$, and $\mathbf{q} \parallel OY$ that propagates along the OX axis in the AFM material $\eta^2 \equiv k_y^2 > 0$ is determined by the equation ($\omega_d \equiv gM_0d$, $s_t^2 \equiv \mu/\rho$, $k = \{0, \eta, h\}$, $k_0^2 \equiv \omega^2/s_t^2$, ρ is the density)

$$[c_{\perp}h^2 + \eta^2 - k_0^2][\mu_{\perp}\eta^2 + h^2] + \frac{4\pi}{\mu}(\beta^2 + \beta_*^2)\eta^2h^2 = 0, \quad (5)$$

$$\tau = -1 \text{ and } 1.$$

As mentioned above, one of the possible mechanisms of formation of bound states in the continuous spectrum of photon radiation in optically anisotropic layered structures can be the optical birefringence effect at least in the layer-forming medium [16]. According to Eq. (5) for the case under consideration (see also Fig. 1b), the MA birefringence effect with change of the branch (refraction cavity of the ordinary MA wave in the AFM material with $\tau = -1$ and 1) caused by the elastic dipole interaction in the case of the incidence of the bulk shear plane wave from the outside on the surface of the AFM material specified by Eq. (2) in the chosen MA configuration with $\mathbf{q} \parallel OY$, $\mathbf{k} \in (Y, Z)$, and $\mathbf{u} \parallel OX$ is possible at the frequency and angle of incidence that ensure the conditions

$$c_{\perp}h^2 - k_0^2 < 0, \quad \mu_{\perp} < 0 \quad (6)$$

in Eqs. (3) and (4). Thus, according to Eqs. (5) and (6), this mechanism of MA birefringence for the elastic shear plane wave incident from outside on the AFM material described by Eqs. (3) and (4) cannot occur under the formal passage to the elastostatic limit $k_0 \rightarrow 0$. This means that the formation of dark modes in the spectrum of radiative bulk magnon polarons through the discussed elastic dipole mechanism is impossible (at any sign of τ in Eqs. (2) and (3) for this MA configuration below a certain critical frequency $\omega = \omega_*$).

Let two half-spaces filled with an isotropic elastic dielectric having the free energy density given by Eq. (1) be separated by a layer of a spatially uniform uniaxial AFM material described by Eqs. (2)–(4) with the thickness $2d$ and the normal vector to the surface $\mathbf{q} \parallel OY$. We suggest that the following system of boundary conditions at the interface between the magnetic

medium specified by Eq. (2) (at $|y| \leq d$) and the nonmagnetic medium described by Eq. (1) (at $|y| > d$) are valid for the considered elastic SH wave with $\mathbf{k} \perp \mathbf{u} \parallel \mathbf{a} \parallel OX$:

$$\mathbf{q}\bar{\sigma}\mathbf{a} = \mathbf{q}\bar{\bar{\sigma}}\mathbf{a}, \quad \mathbf{u}\mathbf{a} = \bar{\mathbf{u}}\mathbf{a}, \quad \mathbf{B}\mathbf{q} = 0. \quad (7)$$

This corresponds to the layer with the thickness $2d$ both surfaces of which have continuous acoustic contact with an infinite medium, and the acoustically ultrathin perfect diamagnetic layer is located at the interface between the magnetic and nonmagnetic media [29]. We begin with the case where the easy magnetic axis of the AFM material specified by Eq. (2) is orthogonal to the normal \mathbf{a} to the plane of incidence ($\mathbf{l}_0 \parallel \mathbf{b} \parallel OZ$). For such a MA configuration ($\mathbf{q} \parallel OY$, $\mathbf{k} \in (Y, Z)$, and $\mathbf{a} \parallel \mathbf{u} \parallel OX$ in Fig. 1a), the spatial distribution of the elastic shear displacement field in the considered antiferromagnetic plate with $\mathbf{q} \parallel OY$, $\tau = -1$ and 1, and $\mathbf{k} = (0, \eta_{\alpha}, h)$, $\alpha = 1$ and 2, taking into account Eqs. (5) and (7) has the form

$$u_x = \sum_{j=1}^2 (A_j c_{jy} + B_j s_{jy}) \exp[i\psi],$$

$$\varphi = \sum_{j=1}^2 \Phi^{(j)} (A_j s_{jy} + B_j c_{jy}) \exp[i\psi], \quad \psi \equiv hz - \omega t, \quad (8)$$

$$B_y = \sum_{j=1}^2 B_y^{(j)} (A_j c_{iy} + B_j s_{jy}) \exp[i\psi],$$

$$\sigma_{yx} = \sum_{j=1}^2 \sigma_{yx}^{(j)} (A_j s_{jy} + B_j c_{jy}) \exp[i\psi],$$

where $c_{iy} \equiv \cosh(|\eta_j|y)$ and $s_{jy} \equiv \sinh(|\eta_j|y)$, $j = 1$ and 2, at $\eta_{1,2}^2 < 0$, and $B_y^{(j)}$, $\Phi_y^{(j)}$, and $\sigma_{yx}^{(j)}$ are the amplitudes of B_y , φ , and σ_{yx} , respectively, calculated from the equations of motion of the infinite AFM material specified by Eq. (2) as a linear response to the partial amplitude for $\mathbf{u} \parallel OX$ with the transverse wavenumber η_j (determined from Eq. (5)) and the spatial structure corresponding to Eq. (8). As a result, using the approach developed in [29, 30] and taking into account magnetostatic boundary conditions in Eq. (7), the spatial structure of the corresponding transition matrix for the considered elastic SH wave and the antiferromagnetic layer with the thickness $2d$ described by Eqs. (2), (5), and (8) can be represented in the form

$$\begin{pmatrix} \mathbf{u}\mathbf{a} \\ \mathbf{q}\bar{\sigma}\mathbf{a} \end{pmatrix}_{y=d} = \begin{pmatrix} T_{11} & T_{12} \\ T_{21} & T_{22} \end{pmatrix} \begin{pmatrix} \mathbf{u}\mathbf{a} \\ \mathbf{q}\bar{\sigma}\mathbf{a} \end{pmatrix}_{y=-d}, \quad (9)$$

$$\bar{T} = \bar{S}(y=d)\bar{S}^{-1}(y=-d) \quad (\tau = \mp 1), \quad (10)$$

$$S_{11} = c_{1y} + F_{AA}c_{2y}, \quad S_{12} = s_{1y} + F_{BB}s_{2y},$$

$$F_{AA} \equiv -\frac{B_y^{(1)}c_{1d}}{B_y^{(2)}c_{2d}}; \quad F_{BB} \equiv -\frac{B_y^{(1)}s_{1d}}{B_y^{(2)}s_{2d}}; \quad (11)$$

$$S_{21} = \sigma_{yz}^{(1)}s_{1y} + \sigma_{yz}^{(2)}F_{AA}s_{2y}, \quad S_{22} = \sigma_{yz}^{(1)}c_{1y} + \sigma_{yz}^{(2)}F_{BB}c_{2y}.$$

Thus, according to the general concepts of the theory of wave processes in layered media [30], at given external parameters $\omega - h$ and $\tilde{Z}_{SH} \equiv \mathbf{q}\tilde{\sigma}\mathbf{a}/\mathbf{ua}$ depending on the sign of \tilde{Z}_{SH}^2 , the proper or improper [31] (leaky) shear MA wave (radiative magnon polaron) can propagate along the considered antiferromagnetic layer described by Eqs. (4), (7), and (9)–(11). The spectrum of this wave is determined from the condition

$$(S_{21} - i\tilde{Z}_{SH}S_{11})(S_{22} - i\tilde{Z}_{SH}S_{12}) = 0, \quad (12)$$

$$\tilde{Z}_{SH} \equiv \tilde{\mu}\sqrt{\omega^2/\tilde{s}_i^2 - h^2},$$

where $\tilde{s}_i^2 \equiv \tilde{\mu}/\tilde{\rho}$, and the resonance transparency condition for this layer has the form

$$T_{21} = -\tilde{Z}_{SH}^2 T_{12}. \quad (13)$$

The spectrum is factorized because the independent propagation of MA SH waves where the elastic stress field can be symmetric or antisymmetric with respect to the middle plane of the magnetic layer is possible in this case. If $\omega < \tilde{s}_i h$ in Eqs. (10)–(12), these equations determine the spectrum of the proper bulk shear MA wave [31] with $\mathbf{u} \parallel OX$ and $\mathbf{l}_0 \parallel OZ$ propagating along the AFM layer described by Eqs. (2)–(5) that is embedded in the infinite nonmagnetic medium specified by Eq. (1) [30]. In particular, Eqs. (10)–(12) in the case $\tilde{Z}_{SH} = \infty$ correspond to the spectrum of the MA SH wave in the AFM layer whose both surfaces are rigidly fixed [30, 32] and $B_y(y = \pm d) = 0$. If $\omega > \tilde{s}_i h$ in Eqs. (10)–(12), the improper (leaky) MA shear wave generally propagates along the considered magnetic layer; the finite width of lines is due to the emission of the elastic bulk shear wave with $\tilde{\mathbf{u}} \parallel OX$ and $\mathbf{k} \in (Y, Z)$ to the infinite medium specified by Eq. (1) (open radiative channel [14, 15]). The analysis of Eqs. (9)–(12) shows that, under the condition

$$(|S_{21}| + |S_{11}|)(|S_{22}| + |S_{12}|) = 0, \quad (14)$$

points in the continuous spectrum of elastic bulk SH waves in the nonmagnetic medium specified by Eq. (1) (i.e., at $\omega > \tilde{s}_i h$) can appear on the (ω, h) plane at which the bulk shear MA wave with $\mathbf{u} \parallel OX$ described by Eqs. (9)–(12) propagating along the AFM layer becomes proper (its radiation field in the medium specified by Eq. (1) is identically zero). The calculation shows that, within the considered model of the magnetoelastic dynamics of the AFM layer described by Eqs. (2)–(5) and (7)–(11), such dark states (bound states in the continuum) of magnon polarons are due

to the elastic dipole mechanism of destructive interference in the open phonon emission channel, which corresponds to the reduced variant of the model [15]. At $\omega > \tilde{s}_i h$, near the degeneracy points of the spectrum of magnon polarons described by Eqs. (9)–(12) and (14), the root (12) for a given frequency of the wave ω can be represented as $h = h'(\omega) + ih''(\omega)$, where $h'' = -\tilde{Z}_{SH}S_{11}/(\partial S_{21}/h)$ if $S_{21}(\omega, h') = 0$ and $h'' = -\tilde{Z}_{SH}S_{12}/(\partial S_{22}/h)$ if $S_{22}(\omega, h') = 0$. It is assumed that ω coincides with one of the degeneracy frequencies of the spectrum of magnon polarons given by Eq. (12), which are determined by Eq. (14). In particular, if this is the degeneracy frequency of the dispersion curves of the v th and ρ th modes ($v, \rho = 1, 2, \dots$), according to Eqs. (12) and (14), the spectrum of symmetric or antisymmetric modes of the same symmetry near the point $h'_v = h'_\rho$ for radiative magnon polarons can be represented as $h = h'_v$ and $h = h'_v + i(h''_v + h''_\rho)$ in terms of the introduced notation (see also [14]). Thus, according to Eqs. (12) and (14), if h tends to a value determined from Eq. (14) as $h'_v = h'_\rho$, then the width of the line caused by the radiative damping of the magnon polaron decreases to zero when approaching this dark state. Following [11], this indicates that the phonon high- Q -factor (supercavity) states in the spectrum of radiative magnon polarons with $\mathbf{u} \parallel \mathbf{a}$ can be implemented within the considered model of the AFM medium. The calculation shows that this circumstance can significantly affect the resonance characteristics of the considered acoustically open magnetic layer. In particular, if the elastic bulk SH plane wave ($\mathbf{k} \in (Y, Z)$, $\mathbf{q} \parallel OY$, $\mathbf{b} \parallel \mathbf{l}_0 \parallel OZ$, and $\mathbf{u} \parallel OX$) is incident from the nonmagnetic medium specified by Eq. (1) on the AFM layer under consideration, the frequency dependence of its amplitude transmission coefficient $W_{SH}(\omega, h)$ has an asymmetric form characteristic of the Fano resonance because of Eqs. (12)–(14). The calculation shows that, depending on the relation between external parameters, the numerator and denominator in $W_{SH}(\omega, h)$ can vanish not only separately but also, under the condition (14), simultaneously (which corresponds to the MA collapse of the Fano resonance according to [33]). According to the analysis of Eqs. (9)–(12), the spectrum of bulk nonexchange elastic dipole magnon polarons propagating along the AFM layer described by Eqs. (2)–(5) and (7) with $\tau = -1$ and 1 and $u_x(y = \pm d) = 0$ at $\mathbf{k} \in (Y, Z)$, $\mathbf{q} \parallel OY$, $\mathbf{b} \parallel \mathbf{l}_0 \parallel OZ$, and $\mathbf{u} \parallel OX$ can be represented in the form ($\kappa_v \equiv \pi v/(2d)$, $v = 1, 2, \dots$)

$$D_v(\omega, h) = 0, \quad D_v(\omega, h)$$

$$\equiv [c_\perp h^2 + \kappa_v^2 - k_0^2][\mu_\perp \kappa_v^2 + h^2] \quad (15)$$

$$+ \frac{4\pi(\beta^2 + \beta_*^2)}{\mu} \kappa_v^2 h^2 = 0.$$

We note that, according to Eq. (15), if the thickness of the magnetic layer is larger than $\pi\sqrt{1 + 4\pi(\beta^2 + \beta_*^2)}/\mu/k_0$ at the frequency $\omega = \omega_\mu$ (i.e., if $\mu_\perp = 0$), branches of the spectrum given by Eq. (15) that constitute an infinite countable set beginning with the mode specified by the number equal to the integer part of $k_0d/(\pi\sqrt{1 + 4\pi(\beta^2 + \beta_*^2)}/\mu) \equiv v_*$ at $\omega = \omega_\mu$ will have a long-wavelength end of the spectrum at $h = 0$. At the same time, first, the modes in the spectrum given by Eq. (15) with the numbers $v < v_*$ in the frequency range $0 < \omega \leq \omega_\mu$ have long-wavelength ends of the spectrum that are not degenerate with each other and with $\omega = \omega_\mu$ at $h = 0$ and, second, the modes of the spectrum given by Eq. (15) with the numbers $v > v_*$ in the frequency range $\omega > \omega_\mu$ have long-wavelength ends of the spectrum that are not degenerate with each other and with $\omega = \omega_\mu$ at $h = 0$. As a result, the elastic dipole interaction induces dark states in the continuous spectrum of radiative magnon polarons with $\mathbf{u} \parallel \mathbf{a}$ for the AFM layer with $\tau = 1$ and -1 in this MA configuration at the ω and h values determined by the relation

$$\omega > \tilde{s}_i h, \quad D_v(\omega, h) = D_\rho(\omega, h), \quad (16)$$

$$v \neq \rho, \quad v, \rho = 1, 2, \dots$$

following from Eqs. (14) and (15).

It is noteworthy that relation (16) ensures also the condition $|W_{SH}(\omega, h)| = 1$, i.e., the complete acoustic transparency of the AFM layer specified by Eq. (7) for the bulk SH plane wave incident from the medium described by Eq. (1). Thus, elastic dipole bound states in the continuum specified by Eq. (14) appear in this magnetic structure at ω and h values satisfying the condition $\omega > \tilde{s}_i h$ and the conditions

$$k_0^2 - c_\perp h^2 = \kappa_v^2 + \kappa_\rho^2 + \frac{h^2}{\mu_\perp} \left[\frac{4\pi(\beta^2 + \beta_*^2)}{\mu} + 1 \right], \quad (17)$$

$$v \neq \rho, \quad v, \rho = 1, 2, \dots$$

following from Eqs. (9)–(12), (15), and (16).

Figure 1c qualitatively shows the character of the formation of these bound states in the continuous spectrum of leaky bulk magnon polarons with $\mathbf{u} \parallel \mathbf{a}$ propagating along the AFM layer with the boundary conditions given by Eq. (7) at $\mathbf{k} \in (Y, Z)$, $\mathbf{q} \parallel OY$, $\mathbf{l}_0 \parallel OZ$, and $\mathbf{u} \parallel OX$ on the (ω, h) plane of the external parameters.

We discuss above only the case where the elastic dipole mechanism of the formation of the MA birefringence effect with a change of the refraction cavity at the interface between the magnetic and nonmagnetic media leads to the appearance of a new type of bound states in the spectrum of phonon radiation of leaky magnon polarons with $\mathbf{u} \parallel \mathbf{a}$ in the AFM layer

with the easy magnetic axis lying simultaneously in the plane of the layer and in the plane of incidence ($\mathbf{l}_0 \parallel \mathbf{b} \parallel OZ$). However, the analysis shows that the discussed elastic dipole mechanism of the formation of bound states in the continuous spectrum of radiative magnon polarons with $\mathbf{u} \parallel \mathbf{a}$ for the AFM layer specified by Eq. (2) can significantly depend on the relative orientation of $\mathbf{l}_0 \parallel OZ$ and $\mathbf{a} \parallel \mathbf{u}$ taking into account the sign of τ in Eq. (2). As an example, we consider the possibility of the MA birefringence effect with change of the refraction cavity for the AFM layer with $\mathbf{l}_0 \parallel \mathbf{a} \parallel OZ$ under boundary conditions specified by Eqs. (7) and $\tau = 1$ and -1 in Eq. (2) and, as a result, the appearance of a new type of bound states in the phonon emission spectrum of leaky magnon polarons with $\mathbf{u} \parallel \mathbf{a}$. The standard calculation shows that coupling equations at $\tau = 1$ and -1 in Eq. (2) for this MA configuration (in Fig. 1a, $\mathbf{q} \parallel OY$, $\mathbf{k} \in (Y, Z)$, and $\mathbf{u} \parallel \mathbf{l}_0 \parallel OZ$) in terms of the notation introduced in Eqs. (2)–(4) have the form

$$\begin{cases} \sigma_{zx} = \mu c_\perp \frac{\partial u_z}{\partial x} + (\tau\beta - i\beta_*)h_y, \\ \sigma_{zy} = \mu c_\perp \frac{\partial u_z}{\partial y} + (\beta + i\beta_*)h_x, \\ B_x = \mu_\perp h_x - 4\pi(\beta - i\beta_*) \frac{\partial u_z}{\partial y}, \\ B_y = \mu_\perp h_y - 4\pi(\tau\beta + i\beta_*) \frac{\partial u_z}{\partial x}. \end{cases} \quad (18)$$

Taking into account that now $\mathbf{k} = (h, \eta, 0)$, we obtain the following dispersion equation for the ordinary MA wave with $\mathbf{u} \parallel \mathbf{l}_0 \parallel OZ$, $\mathbf{k} \in (X, Y)$ propagating in the infinite AFM medium specified by Eq. (18):

$$(\eta^2 + h^2) \left[c_\perp + \frac{4\pi\beta^2}{\mu\mu_\perp} \frac{4\eta^2 h^2}{(\eta^2 + h^2)^2} \right] = k_0^2 \quad (\tau = 1), \quad (19)$$

$$c_\perp(\eta^2 + h^2) = k_0^2, \quad k_0^2 \equiv \omega^2/s_i^2 \quad (\tau = -1).$$

As a result, unlike the AFM medium with $\tau = -1$, for the AFM medium with $\tau = 1$, the elastic dipole interaction can also induce the MA birefringence effect with change of the branch of the ordinary MA wave with $\mathbf{u} \parallel OZ$ and $\mathbf{k} \in (X, Y)$ under the conditions

$$2h^2(1 + 2\chi^2) < k_0^2/c_\perp, \quad h^2 > k_0^2/c_\perp, \quad (20)$$

$$\chi^2 \equiv 4\pi\beta^2/(\mu\mu_\perp c_\perp).$$

We emphasize that the considered mechanism of MA birefringence for the elastic shear plane wave incident from outside on the AFM medium with $\tau = 1$ at $c_\perp\mu_\perp < 0$ ($\chi^2 < 0$) is now possible not only at $2k_0d > \pi$ but also at the formal passage to the elastostatic limit $k_0 \rightarrow 0$ in Eqs. (19) and (20). This means that dark states in the spectrum of radiative magnon polarons $\mathbf{k} \in (X, Y)$ can also be formed in this case, but at frequencies below the frequency of the homogeneous

AFM resonance ($\omega = \omega_*$). At $\eta^2 > 0$, Eqs. (19) determine, depending on the frequency, the form of the section of the wave vector surface of the ordinary shear MA wave by the plane of incidence ($\mathbf{k} \in (X, Y)$) for the infinite AFM medium specified by Eq. (2) with $\tau = 1$ and -1 and coupling Eqs. (3), (4) and (18), (4), respectively (both with (at $k_0 \neq 0$) and without (at $k_0 \rightarrow 0$) the inclusion of the acoustic delay effect). As in Fig. 1b, the frequency-dependent appearance of segments with a negative Gaussian curvature, which is characteristic of the acoustic bireflection effect, is of particular interest (see also [21–24]). The sections of the wave vector surface by the plane of incidence for the shear elastic wave in the easy-axis AFM medium specified by Eq. (2) with $\tau = 1$ for elastic dipole MA birefringence with change of the refraction cavity described by Eqs. (4) and (19) are qualitatively shown in Fig. 2a at $\mathbf{k} \in (Y, Z)$, $\mathbf{q} \parallel OY$, and $\mathbf{l}_0 \parallel \mathbf{a} \parallel OZ$. In this case, the calculation similar to Eqs. (8)–(12) indicates that, since now $k = \{h, \eta_\alpha, 0\}$, the spectrum of the bulk MA wave propagating along such limited AFM medium specified by Eqs. (2)–(5) with $\tau = 1$ and -1 and boundary conditions $B_y(y = \pm d) = 0$ and $u_z(y = \pm d) = 0$ is determined from the relation ($\kappa_v \equiv \pi v / (2d)$, $v = 1, 2, \dots$)

$$D_v(\omega, h) = 0, \quad \text{where}$$

$$D_v(\omega, h) \equiv (\kappa_v^2 + h^2) \quad (21)$$

$$\times \left[c_\perp + \frac{4\pi\beta^2}{\mu\mu_\perp} \frac{4\kappa_v^2 h^2}{(\kappa_v^2 + h^2)^2} \right] - k_0^2, \quad \text{if } \tau = 1;$$

$$D_v(\omega, h) \equiv c_\perp(\kappa_v^2 + h^2) - k_0^2, \quad \text{if } \tau = -1.$$

Figure 2b shows the qualitative character of formation of this type of bound states in the continuous spectrum of leaky bulk magnon polarons with $\mathbf{u} \parallel \mathbf{a}$ propagating along the considered AFM layer with $\tau = 1$ and boundary conditions given by Eqs. (7) at $\mathbf{k} \in (Y, Z)$, $\mathbf{q} \parallel OY$, and $\mathbf{l}_0 \parallel \mathbf{u} \parallel OZ$ on the (ω, h) plane of the external parameters for $\omega > \tilde{s}h$ corresponding to Eqs. (16) and (21). In the limit $k_0 \rightarrow 0$, $D_v(\omega, h) = 0$ in Eqs. (21) determines the spectrum of bulk nonexchange elastic dipole magnons propagating along the AFM layer with $\tau = 1$ and the outer surfaces coated with a perfect diamagnetic material. We emphasize that dark modes in the spectrum of radiative SH magnon polarons can be formed in this case if $1 + 4\chi^2 < 0$ and, thereby, in two frequency ranges according to Eq. (4) because the condition $c_\perp \mu_\perp < 0$ ($\chi^2 < 0$) is a necessary condition for Eq. (20). In this case, this type of bound states in the continuum can be formed even in the elastostatic limit $k_0 \rightarrow 0$. The long-wavelength ends of the spectrum of modes of bulk MA waves in the considered layer in the range $\omega_* < \omega \leq \omega_\mu$ with the

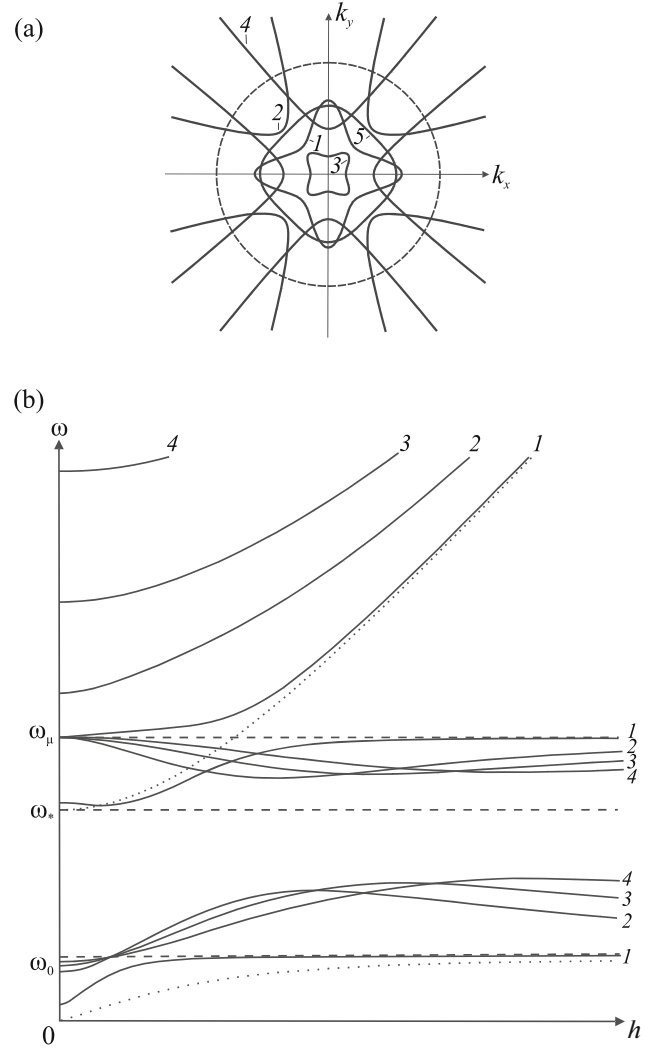

Fig. 2. (a) Qualitative form of the section of the wave vector surface of the shear elastic wave with $\mathbf{u} \parallel \mathbf{l}_0 \parallel \mathbf{a} \parallel OZ$ in the easy-axis antiferromagnet specified by Eq. (2) with $\tau = 1$ in Eq. (19) by the plane of incidence $k \in XY$ in the elastic dipole mechanism of the magneto-acoustic birefringence (19) at (1) $c_\perp > 0$, $\mu_\perp > 0$ ($\chi^2 > 1/3$); (2) $c_\perp < 0$, $\mu_\perp > 0$; (3) $\mu_\perp < 0$, $c_\perp > 4\pi\beta^2 / (\mu|\mu_\perp|)$, $|\chi^2| > 1/3$; (4) $0 < c_\perp < 4\pi\beta^2 / (\mu|\mu_\perp|)$, $\mu_\perp < 0$; (5) $c_\perp > 0$, $\mu_\perp > 0$, $\chi^2 < 1/3$. (b) Bound states in the continuum, i.e., degeneracy points in the spectrum of radiative bulk magnon polarons with $\mathbf{a} \parallel \mathbf{l}_0 \parallel OZ$ and $\mathbf{q} \parallel OY$ for Eqs. (16) and (21) with $\tau = 1$. Lines 1–4 correspond to $\kappa_v^2 = 0.002, 0.04, 0.08,$ and 0.16 in Eq. (21), respectively; $\omega_0^2 = 0.3\omega_{me}^2$, $\varepsilon = 0.8$.

numbers $v < v_*$, where v_* is the integer part of $d\omega_\mu / \pi s_t$, differ from $\omega = \omega_\mu$. The long-wavelength ends of the spectrum of the other modes with the numbers $v \geq v_*$ in the range $\omega_* < \omega \leq \omega_\mu$ coincide with $\omega = \omega_\mu$. At the same time, the long-wavelength

ends of the spectrum of the other modes with the numbers $\nu < \nu_*$ in the range $\omega \geq \omega_\mu$ coincide with $\omega = \omega_\mu$. Finally, modes of the bulk MA waves in the considered layer with the numbers $\nu \geq \nu_*$ in the range $\omega \geq \omega_\mu$ do not have the long-wavelength end of the spectrum at $\omega = \omega_\mu$.

Let an acoustically continuous system of N identical AFM layers specified by Eq. (2) with $\tau = 1$ and -1 with ultrathin perfect diamagnetic layers between them be embedded in a nonmagnetic medium specified by Eq. (1) and boundary conditions specified by Eqs. (7) be imposed on the outer surface of this structure with $\mathbf{q} \parallel OY$ (see also [29]). A calculation similar to the above calculation shows that, for both MA configurations considered above and for each of the pairs of ω and h values determined above for the single AFM layer that correspond to elastic dipole bound states in the continuum described by Eqs. (15), (16), and (21), a system of $N - 1$ dark states with the same ω and h values but a different character of the spatial distribution of the elastic displacement field $\mathbf{u} \parallel \mathbf{a}$ over the thickness of the layered magnetic heterostructure appears in the spectrum ($\omega > \tilde{s}, h$) of radiative magnon polarons with $\mathbf{u} \parallel \mathbf{a}$ if $\mathbf{l}_0 \parallel OZ$. These degenerate dark states for the corresponding MA configuration will also determine the conditions for the collapse of the MA Fano resonance if the bulk plane wave with $\mathbf{u} \parallel \mathbf{a}$ is incident from the medium specified by Eq. (1) on the surface of the considered multilayer structure.

To summarize, we have determined for the first time conditions for a new mechanism of formation of interference bound states in the continuum [12, 15] of radiative magnon polarons in an acoustically open layered “antiferromagnet–perfect diamagnet” magnetic heterostructure. This is due to the destructive interference of phonon radiation fields of propagating leaky bulk shear MA waves because the elastic dipole mechanism of acoustic birefringence with change of the refraction cavity occurs at the interface between the magnetic and nonmagnetic media. In this case, near such bound states in the continuum, one of the propagating leaky bulk shear MA waves can be a forward wave and the second wave can be a backward wave. Simultaneously with the implementation of the found type of interference bound states in the continuum, the collapse of the magnetoacoustic Fano resonance becomes possible (the numerator and denominator of the amplitude transmission coefficient vanish simultaneously). Near the indicated dark states, the line associated with radiative damping of the corresponding leaky bulk MA wave can be arbitrarily narrow within the considered nondissipative model (see also [15]). By analogy with photonics [11–13], this can be considered as the appearance of super-resonance states in the phonon spectrum of leaky magnon polarons near bound states in the continuum. The type of dark states found in this work can lie in the frequency

range below the minimum critical frequency for the elastic bulk shear wave propagating along the magnetic layer. Finally, this type of bound states in the continuum exists already in the elastostatic limit (neglecting the finiteness of the velocity of the shear elastic wave in the infinite magnetic material) because of the hybridization of the phonon and dipole mechanisms of the spin–spin interaction in the magnetic layer. All listed effects depend on the orientation of the plane of incidence of the elastic SH wave relative to the easy magnetic axis of the antiferromagnetic material. As a magnetic medium, we have considered a uniaxial antiferromagnet in the collinear phase with the spin structure that can be even or odd with respect to the easy magnetic axis. We emphasize that mechanisms of formation of bound states in the continuum previously studied in [24, 25] are impossible altogether for the MA configurations and antiferromagnet model considered in this work.

FUNDING

This work was supported by the Ministry of Science and Higher Education of the Russian Federation (state contract with the Kotelnikov Institute of Radio Engineering and Electronics, Russian Academy of Sciences).

CONFLICT OF INTEREST

The authors declare that they have no conflicts of interest.

OPEN ACCESS

This article is licensed under a Creative Commons Attribution 4.0 International License, which permits use, sharing, adaptation, distribution and reproduction in any medium or format, as long as you give appropriate credit to the original author(s) and the source, provide a link to the Creative Commons license, and indicate if changes were made. The images or other third party material in this article are included in the article’s Creative Commons license, unless indicated otherwise in a credit line to the material. If material is not included in the article’s Creative Commons license and your intended use is not permitted by statutory regulation or exceeds the permitted use, you will need to obtain permission directly from the copyright holder. To view a copy of this license, visit <http://creativecommons.org/licenses/by/4.0/>.

REFERENCES

1. A. Hirohata, K. Yamada, Y. Nakatani, I.-L. Prejbeanu, B. Diény, P. Pirro, and B. Hillebrands, *J. Magn. Mater.* **509**, 166711 (2020).
2. Y. Li, W. Zhang, V. Tyberkevych, W.-K. Kwok, A. Hoffmann, and V. Novosad, *J. Appl. Phys.* **128**, 130902 (2020).
3. A. G. Gurevich and G. A. Melkov, *Magnetization Oscillations and Waves* (Nauka, Moscow, 1994; CRC, Boca Raton, FL, 1996).

4. W.-G. Yang and H. Schmidt, *Appl. Phys. Rev.* **8**, 021304 (2021).
5. K. Yu, N. X. Fang, G. Huang, and Q. Wang, *Adv. Mater.* **30**, 1706348 (2018).
6. A. Kamra, H. Keshtgar, P. Yan, and G. E. W. Bauer, *Phys. Rev. B* **91**, 104409 (2015).
7. Y. Li, C. Zhao, W. Zhang, A. Hoffmann, and V. Novosad, *APL Mater.* **9**, 060902 (2021).
8. D. A. Bozhko, V. I. Vasyuchka, A. V. Chumak, and A. A. Serga, *J. Low Temp. Phys.* **46**, 383 (2020).
9. A. A. Lyapina, D. N. Maksimov, A. S. Pilipchuk, and A. F. Sadreev, *J. Fluid Mech.* **780**, 370 (2015).
10. I. Deriy, I. Toftul, M. Petrov, and A. Bogdanov, arXiv: 2104.05539 (2021).
11. M. Rybin and Y. Kivshar, *Nature (London, U.K.)* **541**, 164 (2017).
12. S. I. Azzam and A. V. Kildishev, *Adv. Opt. Mater.* **9**, 2001469 (2021).
13. K. Koshelev, S. Kruk, E. Melik-Gaykazyan, J.-H. Choi, A. Bogdanov, H.-G. Park, and Y. Kivshar, *Science (Washington, DC, U. S.)* **367**, 288 (2020).
14. C. W. Hsu, B. Zhen, A. D. Stone, J. D. Joannopoulos, and M. Soljačić, *Nat. Rev. Mater.* **1**, 16048 (2016).
15. H. Friedrich and D. Wintgen, *Phys. Rev. A* **32**, 3231 (1985).
16. J. Gomis-Bresco, D. Artigas, and L. Torner, *Nat. Photon.* **11**, 232 (2017).
17. S. V. Tarasenko and V. G. Shavrov, *JETP Lett.* **113**, 477 (2021).
18. H. van de Vaart and H. Matthews, *Appl. Phys. Lett.* **16**, 153 (1970).
19. Yu. V. Gulyaev and P. E. Zil'berman, *Izv. Vyssh. Uchebn. Zaved., Fiz.* **31**, 6 (1988).
20. B. N. Filippov, Preprint IMPh No. 80/1 (Inst. Met. Phys. Ural Sci. Center of Acad. Sci. USSR, Sverdlovsk, 1980).
21. M. K. Balakirev and I. A. Gilinskii, *Waves in Piezoelectric Crystals* (Nauka, Novosibirsk, 1982) [in Russian].
22. J. P. Parekh and H. L. Bertoni, *J. Appl. Phys.* **44**, 2866 (1973).
23. Yu. V. Gulyaev, S. V. Tarasenko, and V. G. Shavrov, *Phys. Usp.* **54**, 573 (2011).
24. S. V. Tarasenko and V. G. Shavrov, *J. Low Temp. Phys.* **46**, 824 (2020).
25. O. S. Sukhorukova, A. S. Tarasenko, S. V. Tarasenko, and V. G. Shavrov, *JETP Lett.* **112**, 420 (2020).
26. E. A. Turov, A. V. Kolchanov, V. V. Men'shenin, I. F. Mirsaev, and V. V. Nikolaev, *Symmetry and Physical Properties of Antiferromagnetics* (Nauka, Moscow, 2001; Cambridge International Science Publishing, Cambridge).
27. Yu. I. Sirotin and M. P. Shaskol'skaya, *Fundamentals of Crystal Physics* (Nauka, Moscow, 1979; Mir, Moscow, 1982).
28. E. A. Turov and V. G. Shavrov, *Sov. Phys. Usp.* **26**, 593 (1983).
29. V. I. Alshits and A. L. Shuvalov, *Phys. Lett. A* **177**, 253 (1993).
30. L. M. Brekhovskikh, *Waves in Layered Media* (Akad. Nauk SSSR, Moscow, 1957; Academic, New York, 1980).
31. T. Tamir and A. A. Oliner, *Proc. Inst. Electr. Eng.* **110**, 310 (1963).
32. M. A. Isaakovich, *General Acoustics* (Nauka, Moscow, 1973) [in Russian].
33. Ch. S. Kim, A. M. Satanin, Yu. S. Dzhoe, and R. M. Kosbi, *J. Exp. Theor. Phys.* **89**, 144 (1999).

Translated by R. Tyapaev