



Enhanced Design of PPE Based on Electrostatic Principle to Eliminate Viruses (SARS-CoV-2)

Uddip Kashyap¹ · Sandip K. Saha¹

Received: 10 April 2020 / Revised: 6 May 2020 / Accepted: 12 May 2020 / Published online: 23 May 2020
© Indian National Academy of Engineering 2020

Abstract

The ongoing global pandemic due to the severe acute respiratory syndrome coronavirus 2 (SARS-CoV-2) is in the crucial stage. The vaccine is still at the developing stage. Currently, the only way to check the spreading of this virus is self-isolation. It is reported that a good number of health workers are infected while treating patients suffering from COVID 19. Therefore, an effort is made to develop a system that can enhance safety and check unwanted viruses. Although the complete specification of the SARS-CoV-2 is yet to be evaluated, the present work considers the characteristic of SARS-CoV-1, which closely relates to that of SARS-CoV-2. The proteins are one of the most important structural and functional molecules of the virus; therefore, few properties of a protein are considered. In this work, we propose a sanitization procedure of the personal protective equipment (PPE), such as gloves and masks, before and after the use, by employing high voltage charge generator (30 kV) from a very low DC source of 5 V to eliminate the virus from the surface of PPE. The positive output is connected to a metallic surface coated with carbon nanotubes (CNT) or a metallic surface ablated using lithography to achieve desired nano-grooves of 200 nm. At the tip of these nano-grooves, a very high electric field is generated which readily ionises the air in the vicinity of the tip. The high electric field alters the induced dipole of the protein of the virus, causing permanent damage in terms of electroporation. Further positive salt ions diffuse into the protein of the viruses, causing it inactive and disintegrate.

Keywords Coronavirus · COVID 19 · Electroporation · Induced dipole · Electrostatics · Polarisation

Introduction: The Technology

The SARS-CoV-2 can spread due to human to human interaction (Ghinai et al. 2020). From the literature, it is learnt that this virus can spread to human very rapidly even during the incubation period. The surface stability of SARS-CoV-2 is very much similar to that of SARS-CoV-1 (Van Doremalen et al. 2020). The ribonucleoprotein complex, which occupies the lumen of the coronavirus, is the significant portion in terms of volume in SARS-CoV-2 or SARS-CoV-1 (Saikatendu et al. 2007). Moreover, the crystal structure of SARS-CoV N-NTD (lumen) witnesses localised segregation of positive and negative charges (Saikatendu et al. 2007).

Further, the homology models of SARS-CoV N-NTD suggest that the electrostatic charge distribution on the surfaces is $-5KT$ to $5KT$, where K and T are Boltzmann constant and temperature, respectively (Saikatendu et al. 2007). Therefore, it is expected that the family of coronavirus will have similar charge clouds in the core (Saikatendu et al. 2007). Many studies also suggested that a residual of net negative charge exists in the core of the coronavirus (Yao et al. 2013).

Few recent works used the principle of electrostatic charges and electric field over the metallic foam to disinfect water (Liu et al. 2013, 2014). The process uses a coating of carbon nano-tubes CNT over the metallic filter where electroporation is carried out to disable the viruses. To create such high step-up DC voltage from a very low DC supply, many efficient circuits are reported in the literature (Fardoun and Ismail 2008; Nouri et al. 2013). Such circuit can be readily optimised to reduce the complexity, similar to the use in mosquito swatter. The negative terminal of the high voltage output can be grounded, and the positive terminal is connected to a metallic layer with a coating of CNT or ablate

✉ Uddip Kashyap
uddipkashyap@gmail.com

Sandip K. Saha
sandip.saha@iitb.ac.in

¹ Department of Mechanical Engineering, Indian Institute of Technology Bombay, Mumbai 400076, India

nano-grooves with Lithography. These metallic layers may present at the most exposed parts of the personal protective equipment (PPE), and the negative terminal is grounded through the shoes. The entire arrangement can be set up as a charging unit in an open space, and the health workers need not carry the electrical circuit on the PPE.

Novelty in the Technology

Currently, it is reported that there is an acute shortage of protection kit for health workers to fight against SARS-CoV-2. Moreover, as reported from various parts of the globe, a good number of health workers is infected by SARS-CoV-2, while serving the patient infected with SARS-CoV-2. With a squeeze in the number of health workers in the country, their safety finds a major concern. As a result, an effort is made to develop a technology that can help health workers to eliminate or disintegrate viruses such as SARS-CoV-2 from their PPE. In this work, we have designed a high voltage charge generator (30 kV) from a very low DC source of 5 V. Similar circuits are already proposed in many studies and many commercial products are also available, such as air purifier (air ioniser) and mosquito swatter. The air ioniser deposits negative static charge over a surface, whereas mosquito swatter uses both positive and negative electrostatic charges to kill the mosquito. However, in the current work, the step-up negative high voltage charge is grounded, and the positive charges are allowed to accumulate over the metallic surface. The accumulated charges over the surface will produce a strong electric field. Further, few research works have reported the effect of a strong electric field on viruses. The high electric field alters the induced dipole of the protein of the virus (Sharp and Honig 1990), causing permanent damage in terms of electroporation (Liu et al. 2013, 2014). Further, positive salt ions diffuse into the protein of the viruses, causing it inactive and disintegrate (Liu et al. 2013). As a result, the developed technology can be tweaked by grounding the negative charge and accumulating the positive charges over the metallic surface. This will produce a high strength electric field which in turn contributes to inactive and disintegrate the viruses.

Developed Technology and the Theory Behind

It is reported that the proteins are one of the most important structural and functional molecules of the virus (Li 2016). Therefore, the initial effort was given to develop an understanding between the electrostatics and the considered protein. Electrostatic deals with static charges.

Few assumptions considered for the study of electrostatic and proteins are as follows (Neves-Petersen and Petersen 2003).

1. All the considered charges are fixed in space and moves at a steady-state condition. Therefore, all the time-dependent terms in the set of Maxwell's equation are zero; thus, resulting in the below mentioned governing equations. Here, ρ is the electric charge density, ϵ_0 is the absolute permeability of the free space, and \vec{E} is the desired electric field.

$$\nabla \cdot \vec{E} = \frac{\rho}{\epsilon_0} \quad (1)$$

$$\nabla \times \vec{E} = 0, \quad (2)$$

where

$$\nabla = \left(\frac{\partial}{\partial x}, \frac{\partial}{\partial y}, \frac{\partial}{\partial z} \right). \quad (3)$$

2. The coupling between the electrostatics and magnetism is neglected due to the fact that both electrostatics and magnetism are dissimilar phenomena when static charges are considered.

Equations 1 and 2 serve as the laws of electrostatics. These two equations can be deduced to a single equation with the knowledge of electrostatics potential and work done. When a point charge is moved from points **a** to **b** in an electric field, work is done against the electric field, and potential is developed, as shown in Fig. 1.

If the point charge q is considered as a unity, then one can write,

$$W = - \int_a^b \vec{F} \cdot d\vec{l} = - \int_a^b (F_x dx + F_y dy + F_z dz) \quad (4)$$

$$F = \frac{1}{4\pi\epsilon_0} \frac{Q \cdot q}{r^2}, \quad (5)$$

where, $d\vec{l}$, Q , r and \vec{F} are the displacement vector, the total charge on the conductor, the displacement between **a**, **b** and the electrical force vector, respectively. If a unit charge is

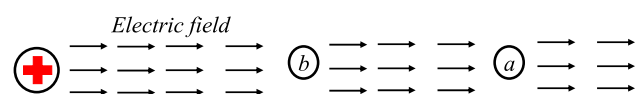

Fig. 1 Electric potential developed when a charge moves from points **a** to **b** in an electric field

considered, then the force in the charge is numerically the same as that of the electric field.

$$W = - \int_a^b \vec{E} \cdot d\vec{l} = - \int_a^b (E_x dx + E_y dy + E_z dz) \quad (6)$$

$$\phi(P) = - \int_{P_0}^P \vec{E} \cdot d\vec{l} \quad (7)$$

$$\phi(P) = \frac{Q}{4\pi\epsilon_0 r} \quad (8)$$

Therefore, Eq. 1 can be deduced after rearranging as follows,

$$\nabla \cdot \nabla\phi = \nabla^2\phi = -\frac{\rho}{\epsilon_0} \quad (9)$$

Equation (9) is known as the Poisson equation. It serves as the base to develop the protein-electrostatics relation. The outer structure of the protein behaves as dielectrics (Kirkwood 1934). The electrostatic interactions in protein are due to the availability of charges, redistribution of charges due to the electric field (electronic polarisation) and reorientation of polar groups in response to an electric field (orientation polarisation) (Moult 1992). Due to the presence of residual charge on the body of this protein, a permanent dipole exists (Petersen et al. 1997). Further, the local electric field produces an induced dipole (Petersen et al. 1997).

The Poisson–Boltzmann equation is deduced, which relates protein and electrostatics (Allison et al. 1986) and is shown below.

$$\nabla \cdot (d_i \nabla\phi) - \kappa^2 d_i \phi + 4\pi\rho_p = 0, \quad (10)$$

where d_i , κ and ρ_p are the overall dielectric constant, Debye length and protein charges, respectively (Allison et al. 1986). The Poisson–Boltzmann introduces electronic induced dipole polarisation through d_i . The polarisation of the protein greatly depends on the electric field. The value of polarization depends on the induced dipole. These induced dipole changes with distortion of the charge cloud (Sharp and Honig 1990; Li 2016). Mathematically, an induced dipole moment (μ) is described by the intensity of the electric field and polarisability factor (α) (Sharp and Honig 1990). A unique feature of this induced dipole is that when a set of these dipoles is developed, it can mutually increase each other polarisation without limit (Sharp and Honig 1990). As it is depended on the electric field, an alteration of the electric field may cause catastrophe leading to sudden damage (Allison et al. 1986) using the following expression.

$$\mu = \alpha \times \vec{E}. \quad (11)$$

From the literature, it is learnt that a net residual of negative charge is present in the coronavirus (Yao et al. 2013). Further, few articles use electroporation to disinfect virus in the flow (Liu et al. 2013, 2014). A very high voltage of 1–100 kV is required for electroporation of viruses and bacteria (Liu et al. 2013). The high voltage induces a very strong electric field, which will, in turn, introduce strong induced dipole contributing to permanent deformation or damage (Allison et al. 1986). Therefore, a DC step-up circuit is designed that converts very small charge (5 V and 2 A) to AC initially and then finally converts to very high DC. Few existing studies reported similar kind of circuits with limited step up (Fardoun and Ismail 2008; Nouri et al. 2013). Based on similar physics, the current circuit is designed using cheap and commonly available components. Figure 2a shows the sketches of the layout and components of the proposed circuit. The expected costing of the circuit is \$3–4, and the approximate weight of the circuit is 100 g.

The detailed breakout and physics of the developed circuit can be found in the existing literature (Nouri et al. 2013). However, the currently developed circuit uses three layers of 1 m length and 0.0002 m diameter copper wire in the primary coil. While fabricating the driver and the feedback coil, flexible 220 V wire of length 0.12 and 0.10 m, respectively, has been used. An additional heat sink is installed along with the transistor Tip 41, as shown in Fig. 2b, to initiate natural convection cooling.

Technology Tweaked in Relevance to COVID-19

The most exposed part of the glove is coated with a metallic layer with either embedded carbon nano-tubes or ablated nano-grooves of 200 nm. A similar arrangement can also be made by placing a metallic porous filter across the mask. However, for ease of understanding only the case with the metallic layer over the exposed part of the gloves is discussed further. The recent experimental work uses such layers to achieve a very high distribution of static charge at the tips of these nanostructures (Liu et al. 2013, 2014). The addition of carbon nano-tubes or ablation of nano-grooves of 200 nm increases the conductivity at the microscopic level. It showed that with such configuration, it builds up even further a strong electric field (2–3 times) at the tips of the nano-structure compared to the overall surface with a supply of average 30 kV (Liu et al. 2014). However, electrostatics being a path function, the surface witnesses a variation in charge distribution.

In the current system, the positive output is connected to the coated/ablated surface, whereas the negative output

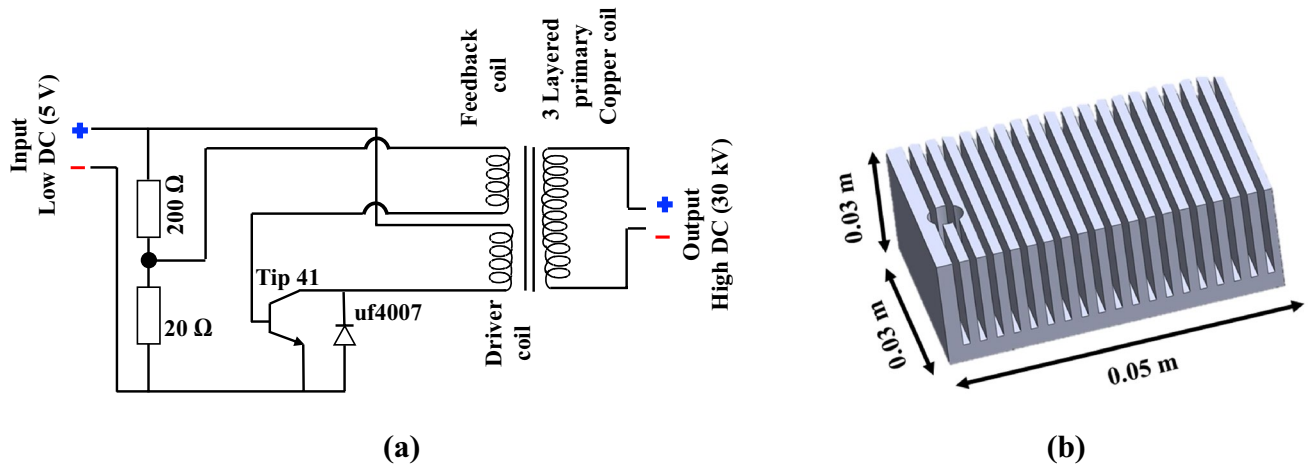

Fig. 2 **a** Circuit diagram for low DC input to high DC step-up voltage and **b** schematic of fin attached to transistor Tip 41

is grounded, as shown in Fig. 3. Aluminium or copper may be used as the metallic surface. The proposed circuit is connected to a 5 V battery. Since the coated/ablated layer is not grounded, the static charge will appear on the surface. The charge density continuously increases over the coated/ablated surface until it ionises the layers of air between the nano-structural grooves of the coated/ablated surface. As the coated/ablated area is positively charged, it will have a net outflow of electric field lines. The electric field is a function of voltage. The effect on a neutral droplet in a strong electric field was studied by Gott (1933) in 1933. The author described two possibilities of charge distribution when the droplet moves in the strong electric field towards the charged surface.

According to the author Gott (1933), neutral droplet develops both positive and negative charges over the surface. The droplet area facing the charged surface induces similar charge as that of the surface and droplet area away from the surface develops dissimilar charges as that of the surface. Further, the author revealed that the quantity of

charge accumulated on the surface of the droplet depends on the propagating speed of the droplet towards the charged surface and the speed of moving of similarly charged ions towards the area of the droplet facing the charged surface (Gott 1933).

Moreover, in the presence of such an electric field when the speed of droplet is higher than that of the similarly charged ions, no charge transfer takes place during the droplet movement towards the charged surface. Whereas when the vice versa occurs, which resembles the suspended aerosol or microdroplet containing viruses, a considerable amount of charge is transferred to the droplet surface (Gott 1933). Thus from the presented theory, it is well understood that when the aerosol approaches the present system, the aerosol or the droplet will accumulate a considerable amount of positive charge.

Further, a group of authors reveals that when this phenomenon happens, higher charge accumulation occurs in the central region (Hagberg et al. 2005). Moreover, the central region experiences a higher degree of polarisation

Fig. 3 Schematic of the current setup

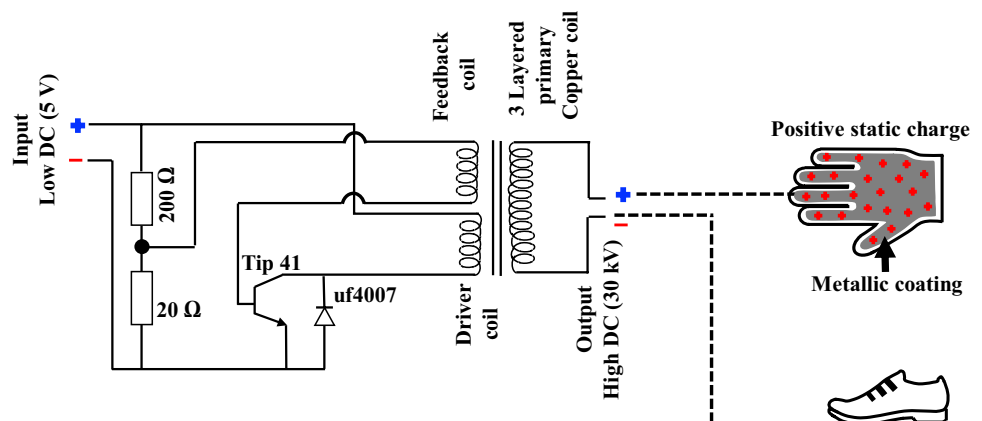

(Hagberg et al. 2005). Similarly, the residual negative electrostatic charge of the lumen of the virus is readily altered by the introduction of a high positive charge. Additionally, the redistribution of the strong electric field along with the positive charge will modify the induced dipole to a great extent (Eq. 10) and thereby induces electroporation (Liu et al. 2013). This phenomenon is followed by electrochemical reactions as well, where the positive salt ion diffuses into the protein. The time required for the electroporation is on the scale of nano-second. However, electrochemical interaction consumes slightly higher time than the electroporation. Therefore, as suggested in the literature (Liu et al. 2013), the average time required to disintegrate the virus is 2–3 s. It can be noted that it is difficult to install such a high voltage charging unit on individual PPE. Moreover, there could be a severe issue of high voltage hazard and electrical corona, if high voltage positive charge is used continuously near the patient. Therefore, it is prudent to install the modified metallic foils over the most exposed part of the PPE to the affected patients. The metallic foil can be either coated with carbon nano-tubes or fabricated with non-grooves using surface lithography. The lithography can be a cheaper option, as it will ablate the surface to produce nano grooves. To sanitize the PPE before and after the use, high voltage positive charges will be created over the modified metallic surface using a charging unit, which is installed remotely in an open space. The negative terminal of the developed circuit is grounded through the shoe of the PPE user, as shown in Fig. 3. A single charging unit may be used by a large number of PPE users. As reported, viruses in water during the purification are eliminated by electroporation within 2 s (Liu et al. 2013). Therefore, as similar physics has opted in the current study, it can be assumed that the effective use of this charging unit for 2–5 min can eliminate viruses and bacteria if these are present on the PPE surface. However, to confirm the exact time required to eliminate the viruses, as well as to drain the charge from the metallic foil, specific experiments are needed to be carried out.

Conclusions

In this proposal, we have presented a possible solution of preventing the virus from infecting the humans by using positive static charges over the metallic surface coated with carbon nanotubes (CNT) or ablated nano-grooves of 200 nm using lithography. These coated/ablated surface can be fixed to the most exposed part on the personal protective equipment (PPE). This setup can be built in a week using readily available, commercially components. Therefore, using such technology can remove or destroy SARS-CoV-2 when it comes in contact with or in the vicinity of the charged surface of the health worker. As a result, the protection of the health worker can be

enhanced. Moreover, the PPE can be reused for several times, which will save the cost.

References

- Allison SA, Northrup SH, McCammon JA (1986) Simulation of biomolecular diffusion and complex formation. *Biophys J* 49(1):167–175
- Fardoun AA, Ismail EH (2008) Ultra sSep-Up DC-DC converter with reduced switch. In: 2008 IEEE International Conference on sustainable energy technologies, pp 425–430
- Ghinai I, McPherson TD, Hunter JC, Kirking HL, Christiansen D, Joshi K, Rubin R, Morales-Estrada S, Black SR, Pacilli M, Fricchione MJ (2020) First known person-to-person transmission of severe acute respiratory syndrome coronavirus 2 (SARS-CoV-2) in the USA. *The Lancet*. 395(10230):1137–1144
- Gott JP (1933) On the electric charge collected by water drops falling through ionized air in a vertical electric field. *Proc R Soc Lond Ser Contain Papers Math Phys Character* 142(846):248–268
- Hagberg D, Brdarski S, Karlström G (2005) On the solvation of ions in small water droplets. *J Phys Chem B* 109(9):4111–4117
- Kirkwood JG (1934) Theory of solutions of molecules containing widely separated charges with special application to zwitterions. *J Chem Phys* 2(7):351–361
- Li F (2016) Structure, function, and evolution of coronavirus spike proteins. *Annu Rev Virol* 3:237–261
- Liu C, Xie X, Zhao W, Liu N, Maraccini PA, Sassoubre LM, Boehm AB, Cui Y (2013) Conducting nanosponge electroporation for affordable and high-efficiency disinfection of bacteria and viruses in water. *Nano Lett* 13(9):4288–4293
- Liu C, Xie X, Zhao W, Yao J, Kong D, Boehm AB, Cui Y (2014) Static electricity powered copper oxide nanowire microbicidal electroporation for water disinfection. *Nano Lett* 14(10):5603–5608
- Moult J (1992) Electrostatics. Current opinion in structural biology. *Curr Opin Struct Biol* 2(2):223–229
- Neves-Petersen MT, Petersen SB (2003) Protein electrostatics: a review of the equations and methods used to model electrostatic equations in biomolecules—applications in biotechnology. *Biotechnol Annu Rev* 9(315):315–395
- Nouri T, Babaei E, Hosseini SH (2013) A generalized ultra step-up DC–DC converter for high voltage application with design considerations. *Electr Power Syst Res* 105:71–84
- Petersen MTN, Martel P, Petersen EI, Drabløs F, Petersen SB (1997) Surface and electrostatics of cutinases. *Methods Enzymol* 284:130–154
- Saikatendu KS, Joseph JS, Subramanian V, Neuman BW, Buchmeier MJ, Stevens RC, Kuhn P (2007) Ribonucleocapsid formation of severe acute respiratory syndrome coronavirus through molecular action of the N-terminal domain of N protein. *J Virol* 81(8):3913–3921
- Sharp KA, Honig B (1990) Electrostatic interactions in macromolecules: theory and applications. *Annu Rev Biophys Biophys Chem* 19(1):301–332
- Van Doremalen N, Bushmaker T, Morris DH, Holbrook MG, Gamble A, Williamson BN, Tamin A, Harcourt JL, Thornburg NJ, Gerber SI, Lloyd-Smith JO (2020) Aerosol and surface stability of SARS-CoV-2 as compared with SARS-CoV-1. *N Engl J Med* 382(16):1564–1567
- Yao Q, Masters PS, Ye R (2013) Negatively charged residues in the endodomain are critical for specific assembly of spike protein into murine coronavirus. *Virology* 442(1):74–81

Publisher's Note Springer Nature remains neutral with regard to jurisdictional claims in published maps and institutional affiliations.