

Temperature analysis of a pin-on-disc tribology test using experimental and numerical approaches

Oday I. ABDULLAH^{1,2,*}, Josef SCHLATTMANN¹

¹ System Technologies and Mechanical Design Methodology, Hamburg University of Technology, Hamburg 21073, Germany

² Department of Energy Engineering, College of Engineering, University of Baghdad, Baghdad-Aljadria 47024, Iraq

Received: 14 January 2016 / Revised: 28 March 2016 / Accepted: 23 April 2016

© The author(s) 2016. This article is published with open access at Springerlink.com

Abstract: The high thermal stresses generated at the interface between the contacting surfaces due to the sliding between parts of sliding system such as friction clutches and brakes. In this work, pin-on-disc test rig was built to find the temperature field during the sliding operation using experimental and numerical approaches. In the experimental approach, infrared camera was used to find the temperature distribution, while in the numerical approach a finite element technique has been used. Analysis has been completed using three-dimensional model to simulate a pin-on-disc system. The numerical results have shown a good agreement compared with the experimental results.

Keywords: transient thermal analysis; pin-on-disc test rig; temperature field; frictional heat; dry contact

1 Introduction

At beginning of the engagement of friction clutch the slipping will occur between the contacting surfaces and high energy will dissipate during this period. The frictional heat generated at the sliding interface causing an increase in the surface temperature of the contacting surfaces of the clutch elements (flywheel, clutch disc and pressure plate in a single-disc clutch system). The surface temperature and the forces involved are sufficiently to produce non-uniform deformation which affects the temperature field and the pressure distribution. As a result of this situation, the high temperature and contact pressure will focus on a small zone of the contact area and this will lead in some cases to premature failure in the friction clutch surfaces. In order to avoid this kind of failure, it should be investigate deeply the thermoelastic behavior of the sliding system to know the safe working condition of any application of sliding systems.

Abdullah and Schlattmann [1–7] investigated the

temperature field and the energy dissipated of the dry friction clutches during a single and repeated engagement assuming a uniform pressure and a uniform wear conditions. They also studied the effect of pressure between contacting surface on the temperature field and the internal energy of clutch disc when it varied with time using two approaches: heat partition ratio approach to compute the heat generated for each part individually whereas the second applies the total heat generated for the whole model using contact model. Furthermore, they studied the effect of engagement time and sliding speed function, thermal load, and dimensionless disc radius (inner disc radius/outer disc radius) on the thermal behavior of the friction clutch at the beginning of engagement.

Al-Shabibi and Barber [8] investigated an alternative method to solve the thermoelastic contact problem with frictional heat generation. Axisymmetric finite element model was built to study the temperature field and the pressure distribution of two sliding disks. Constant and varying speeds were considered in this analysis. The results show that the initial temperature is shown to be crucial since it represents the particular

* Corresponding author: Oday I. ABDULLAH.
E-mail: odayia2006@yahoo.com

solution, which can have quite irregular form, and this situation is especially true when the system operates above the critical speed.

Lee et al. [9] analyzed the effects of three load conditions of thermal loading, centrifugal force and contact pressure of diaphragm spring on pressure plate of a clutch system. The results show a significant effect of thermal loading and contact pressure that suggested an increase in the thickness of pressure plate to enhance the thermal capacity of pressure plate so that the thermal stresses may be reduced.

Gao and Barber [10] simulated the engagement of wet clutches using Berger's model and torque equations. They studied the fluid viscosity, friction characteristics, material permeability, moment of inertia, groove area ratio, and Young's modulus. One big concern of the wet clutch engagement is the engagement time which affects the frictional heat generated and thus the temperature. They found out that the viscosity and friction curves affect the engagement time and torque response. The moment of inertia has a big influence on the engagement time rather than the torque. Permeability, groove area and Young's modulus have less effect on the torque than the other parameters.

Zagrodzki [11] studied the frictional heating in sliding systems and the effect of sliding speed on the stability of the system when the sliding speed exceeds the critical value. Finite element model was used to investigate the transient thermoelastic process, and spatial discretization and modal superposition is presented. Constant sliding speed was performed in this analysis. The transient solution includes both of homogenous part (corresponding to the initial condition) and non-homogenous part (represents the background process). The results show that the important parameters which contribute in the background process are the nominal process equivalent to uniform pressure distribution in isothermal case and the other is the pressure variation caused by geometric imperfection or by design features.

Shahzamanian et al. [12] studied the transient and contact analysis of functionally graded (FG) brake disk. The Coulomb contact friction is considered between the pad and the brake disc. It was found that the contact pressure and contact total stress increase with an increase in the contact stiffness factor.

Gao and Lin [13] used a transient finite element technique to analyze the temperature field in a solid rotor of a brake system with appropriate thermal boundary conditions. Effects of moving heat source (pad) with a relative sliding speed variation were considered. The results show that the operating characteristics of the brake have potential effects on the surface temperature distribution and the maximum contact temperature.

The sliding speed has a significant effect on the wear rate and the heat generated due to friction between parts of the sliding system. The surface temperature of the clutches depends on the sliding speed and the contact pressure. When the sliding speed increases the contact surfaces will be soft and the friction will decrease. The relation between the friction and the sliding speed plays an important role to determine the shudder possibility of any clutch system [14, 15].

In this work thermoelastic model is developed to investigate the heat generated (heat flux) and the temperature field of a pin-on-disc system during sliding operation. Fully coupled thermal-mechanical approach has been developed to find the solution of thermoelastic problem of the sliding systems in dry condition. Furthermore, a pin-on-disc system has been built to measure the temperature field (using infrared camera) and compare the results with the results obtained using numerical approach.

2 Failures in sliding systems

The designers of the sliding systems such as automotive clutches and brakes need the sufficient knowledge about the friction and wear performance of the friction pair during the engagement. This knowledge can be used as a base to predict the performance and lifetime of the sliding systems. For example when the clutch starts to engage high energy will dissipate during this period by the frictional heat generation due to the interaction between the sliding surfaces which cause an increase of the surfaces temperature of the rubbing bodies. The local temperatures at the interface will occur and their values will oscillate depending on the actual contact area and the surface roughness of the contacting bodies. The accurate calculation of the heat

generation and the surface temperature is considered as the key to predict the clutch performance, wear characteristics, the suitable mating surfaces and the lifetime of the contacting surfaces. Figure 1 shows the effective variables on the thermo-mechanical behavior of dry sliding systems.

3 Finite element formulation

The fully thermal-mechanical approach used only one model to represent the sliding system. The main advantage of this approach is that it can be applied to unsymmetrical load to investigate more details about the stability situation in the sliding system (symmetric and unsymmetric geometries). Figure 2 shows the flowchart of finite element simulation of a coupled field problem of any sliding system using this approach.

In order to verify this approach, the temperatures are calculated and compared for a block sliding over another fixed block taken into account the effect of friction between the blocks as shown in Fig. 3 [16].

Table 1 lists the material and geometric properties of the case study in Ref. [16]. The comparison of the results is presented in the Table 2. A good agreement is obtained which proves this approach.

This section also presents the steps to simulate the frictional sliding between a steel pin and friction disc using ANSYS software. There are three basic types of contact used in ANSYS software: single contact, node-to-surface contact, and surface-to-surface contact. Surface-to-surface contact is the most common type of contact used for bodies that have arbitrary shapes with relative large contact areas. This type of contact is most efficient for bodies that experience large values of relative sliding such as block sliding on a plane or sphere sliding within a groove [17]. Surface-to-surface contact is the type of contact assumed in this analysis. The elements are used for contact elastic model in this analysis are:

- SOLID226 (structural-thermal): used for all elements of pin and disc.
- "CONTA174": used for contact surface of the steel pin.

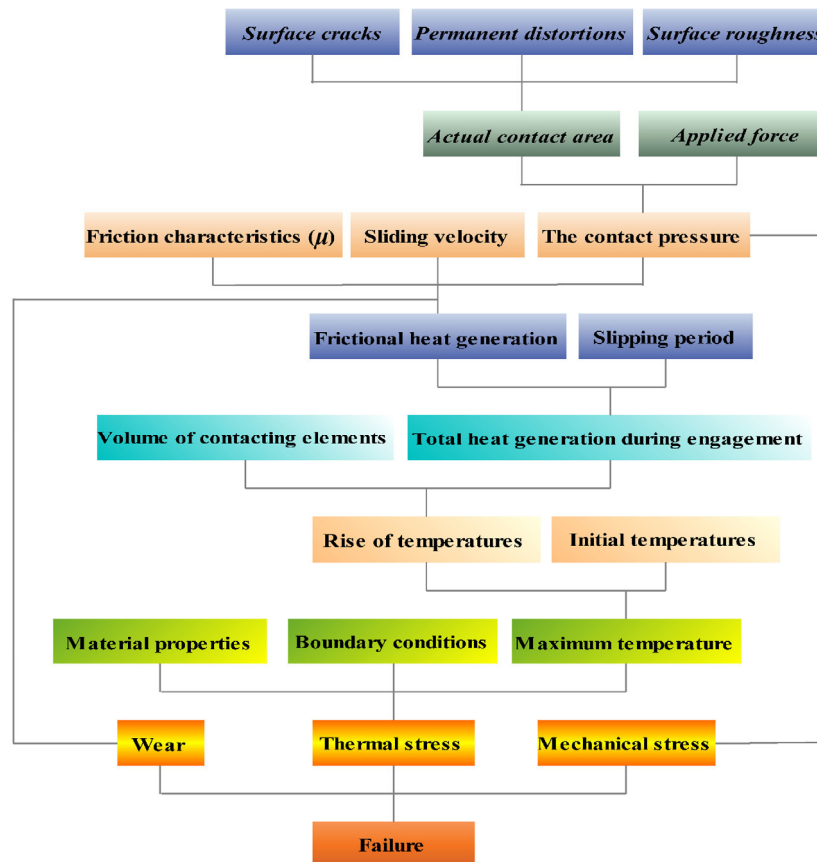

Fig. 1 Diagram of the effective variables on the thermo-mechanical behavior of dry sliding systems.

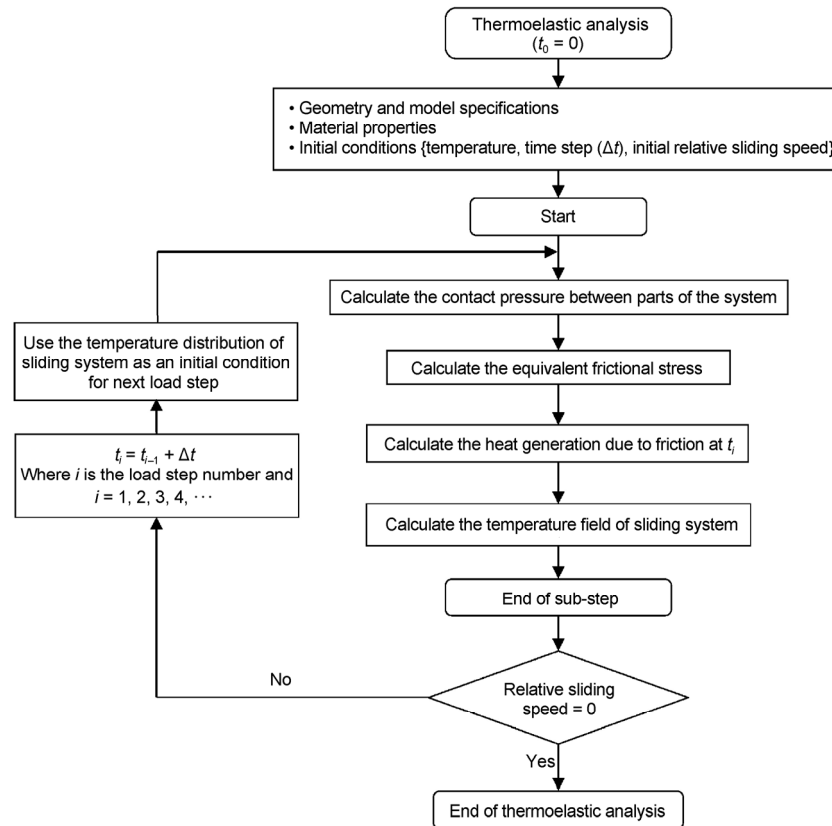

Fig. 2 Flowchart of finite element simulation of fully thermal-mechanical approach.

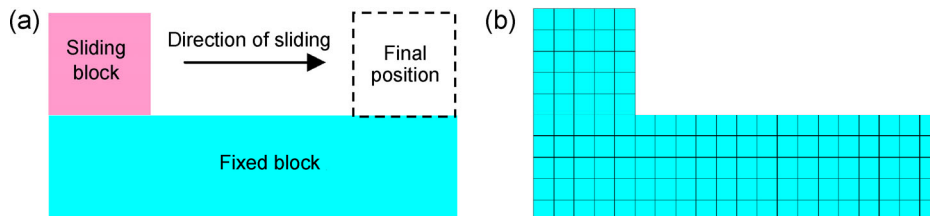

Fig. 3 FE model of block sliding over another fixed block [16]: (a) sliding model, (b) FE model (No. of total elements = 125).

- “TARGE170”: used for the target surface of the frictional disc.

Figure 4 shows the schematic details of all elements that have been used in contact analysis.

The stiffness relationship between contact and target surfaces will decide the amount of the penetration. Higher values of contact stiffness will decrease the amount of penetration, but can lead to ill-conditioning of the global stiffness matrix and convergence difficulties. Lower values of contact stiffness can lead to certain amount of penetration and the values of contact stiffness can be low enough to facilitate convergence of the solution. The contact stiffness for an element of

area A is calculated using the following formula [18]:

$$F_{kn} = \int \{f_i\}(e) \{f_i\}^T dA \quad (1)$$

where f is the shape function and e is the elastic restraining stiffness which is dependent on the material properties. The default value of the contact stiffness factor (F_{kn}) is 1, and it is appropriate for bulk deformation. If bending deformation dominates the solution a smaller value of $F_{kn} = 0.1$ is recommended [17]. There are five algorithms used for surface-to-surface contact type:

1. Penalty method: this algorithm used constant “spring” to establish the relationship between the two

Table 1 Material and geometric properties [16].

| Parameters | Values |
|--|------------------------|
| Height (sliding block) (mm) | 1.25 |
| Width (sliding block) (mm) | 1.25 |
| Height (fixed block) (mm) | 1.25 |
| Width (fixed block) (mm) | 5 |
| Coefficient of friction, μ [1] | 0.2 |
| Young’s modulus of friction material of both blocks (N/mm ²) | 7,000 |
| Poisson’s ratio for both blocks | 0.3 |
| Density of both blocks (Ns ² /mm ⁴) | 2.7×10^{-9} |
| Specific heat of both blocks (mm ² /(s ² K)) | 9×10^8 |
| Conductivity of both blocks (N/(sK)) | 150 |
| Thermal expansion of both blocks (K ⁻¹) | 23.86×10^{-6} |
| Initial speed (mm/s) | 0 |
| Initial temperature (K) | 0 |

Table 2 Values of the temperatures of a block sliding over another fixed block.

| | T (K) (sliding block) | T (K) (fixed block) |
|-----------|-----------------------|---------------------|
| Ref. [16] | 1.235 | 0.309 |
| Present | 1.234 | 0.3086 |
| Error (%) | 0.08 | 0.12 |

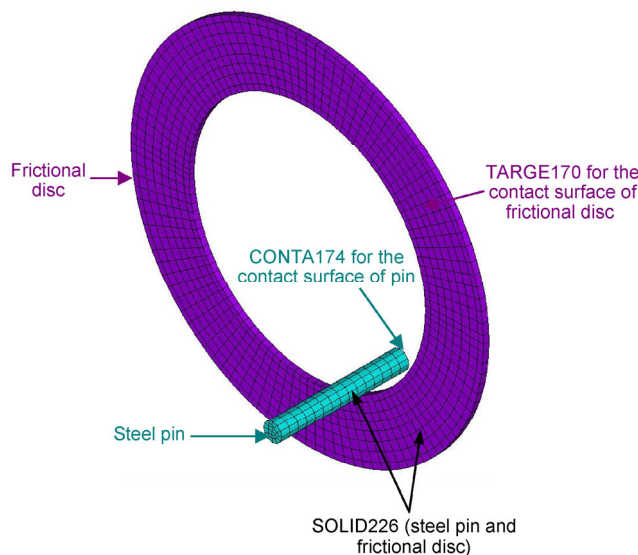

Fig. 4 Elements which used in the sliding simulation of a pin-on-disc test.

contact surfaces (Fig. 5). The contact force (pressure) between two contact bodies can be calculated as follows:

$$F_n = k_n x_p \tag{2}$$

where F_n is the contact force, k_n is the contact stiffness and x_p is the distance between two existing nodes or separate contact bodies (penetration or gap).

2. Augmented Lagrange (default): this algorithm is an iterative penalty method. The constant traction (pressure and frictional stresses) is augmented during equilibrium iterations so that the final penetration is smaller than the allowable tolerance. This method usually leads to better conditioning and is less sensitive to the magnitude of the constant stiffness. The contact force (pressure) between two contact bodies is

$$F_n = k_n x_p + \lambda \tag{3}$$

where λ is the Lagrange multiplier component.

3. Lagrange multiplier on contact normal and penalty on tangent: this method applied on the constant normal and penalty method (tangential contact stiffness) on the frictional plane. This method enforces zero penetration and allows small amount of slip for the sticking contact condition. It requires chattering control parameters, as well as the maximum allowable elastic slip parameter.

4. Pure Lagrange multiplier on contact normal and tangent: this method enforces zero penetration when contact is closed and “zero slip” when sticking contact occurs. This algorithm does not require contact stiffness. Instead it requires chattering control parameters. This method adds contact traction to the model as additional degrees of freedom and requires additional iterations to stabilize contact conditions. It often increases the computational cost compared to the augmented Lagrangian method.

5. Internal multipoint constraint: this method is used in conjunction with bonded contact and no separation contact to model several types of contact assemblies and kinematic constraints.

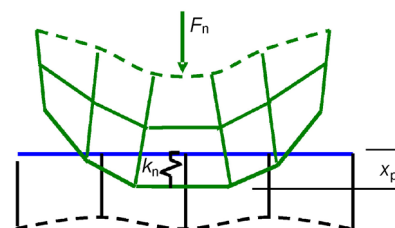

Fig. 5 Contact stiffness between two contact bodies.

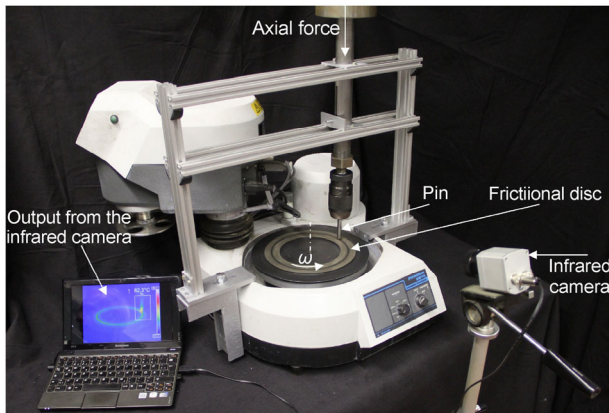
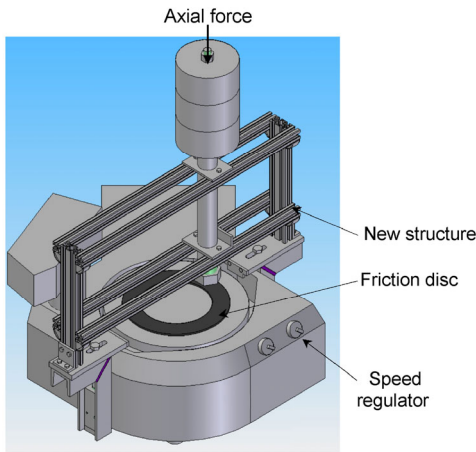

Fig. 7 Test rig and temperature measurement of a pin-on-disc test.

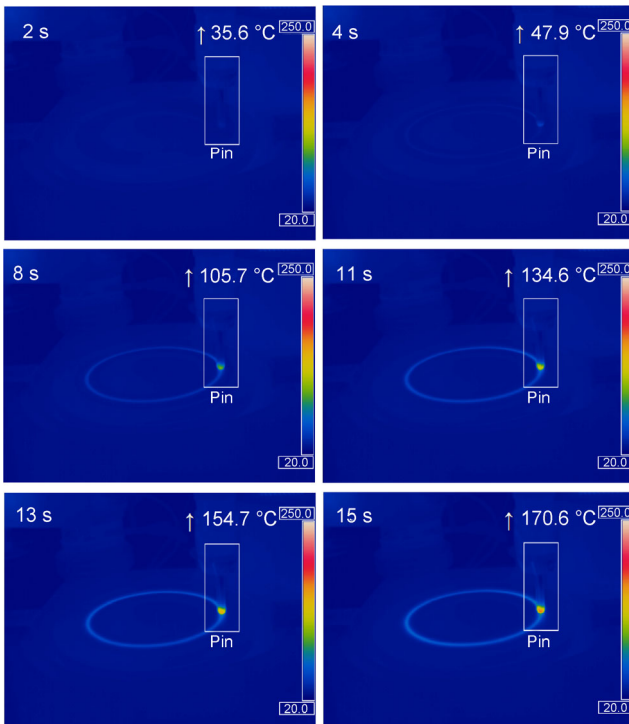

Fig. 8 Values of temperature which are calculated using infrared camera during the sliding operation.

The numerical model of the sliding between a steel pin and frictional disc is simulated using finite element method to investigate the temperature field during the sliding and compared with the experimental results. The simulation couple between thermal and structural effects is used to calculate the pressure distribution between contact surfaces and the temperature field of the discs with time but in this work the surface temperature is considered as the criteria to compare the results obtained from the numerical and experimental approaches. Figure 9 shows the history of the maximum temperatures during the sliding process, and the comparison has been made between the numerical and experimental approaches. A good agreement is obtained which proves the numerical model to deal with the sliding system in dry condition.

5 Conclusions

In this paper, the solution of sliding problem including the frictional heating between a steel pin and friction disc during the sliding operation has been performed. Three-dimensional finite element model was built to obtain the temperature field and the heat generation due to friction.

It can be seen that the average values of temperature of steel pin are higher than the average temperature of frictional disc. This situation occurs due to the fact of using low values of thermal conductivity for friction materials. The thermal significant variation will be

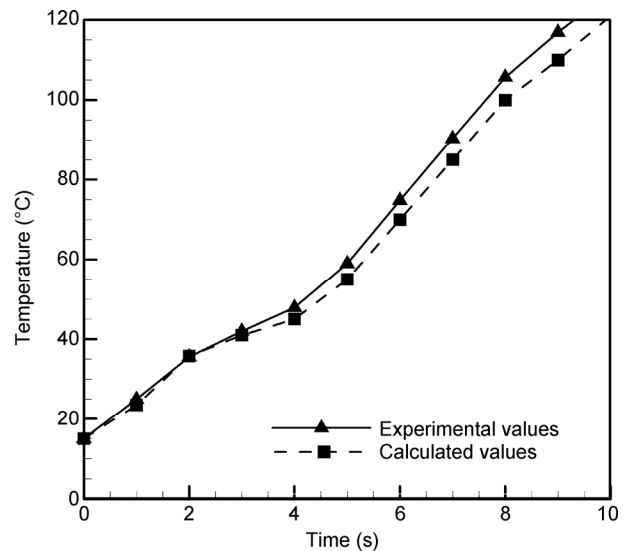

Fig. 9 History of the temperature during the sliding operation.

just near the contact area, and the thermal effect decreases when moving away from the contact area. Therefore, it is very important to use the frictional materials which have good thermal properties in the sliding systems, e.g., automotive brakes and clutches, to improve the thermal behavior and to increase the lifetime of the contact elements.

This study presents a promising design tool to investigate the effect of materials type, surface roughness, boundary conditions, and the material properties dependent temperatures on the thermoelastic phenomena of sliding systems.

Open Access: The articles published in this journal are distributed under the terms of the Creative Commons Attribution 4.0 International License (<http://creativecommons.org/licenses/by/4.0/>), which permits unrestricted use, distribution, and reproduction in any medium, provided you give appropriate credit to the original author(s) and the source, provide a link to the Creative Commons license, and indicate if changes were made.

References

- [1] Abdullah O I, Schlattmann J. The effect of disc radius on heat flux and temperature distribution in friction clutches. *J Adv Mater Res* **505**: 154–164 (2012)
- [2] Abdullah O I, Akhtar M J, Schlattmann J. Investigation of thermo-elastic behavior of multidisk clutches. *J Tribol* **137**(1): 1–9 (2015)
- [3] Abdullah O I, Schlattmann J. Effect of band contact on the temperature distribution for dry friction clutch. *J Tribol Ind* **35**(4): 317–329 (2013)
- [4] Abdullah O I, Schlattmann J. The correction factor for rate of energy generated in the friction clutches under uniform pressure condition. *J Adv Theor Appl Mech* **5**(6): 277–290 (2012)
- [5] Abdullah O I, Schlattmann J. Finite element analysis of temperature field in automotive dry friction clutch. *J Tribol Ind* **34**(4): 206–216 (2012)
- [6] Abdullah O I, Schlattmann J. An investigation into the thermal behavior of the grooved dry friction clutch. *J Tribol* **136**(3): 1–6 (2014)
- [7] Abdullah O I, Schlattmann J. Stresses and deformations analysis of a dry friction clutch system. *J Tribol Ind* **35**(2): 155–162 (2013)
- [8] Al-Shabibi A M, Barber J R. Transient solution of the unperturbed thermoelastic contact problem. *J Therm Stresses* **32**(3): 226–243 (2009)
- [9] Lee C Y, Sup C I, Chai Y S. Finite element analysis of an automobile clutch system. *J Key Eng Mater* **353–358**: 2707–2711 (2007)
- [10] Gao H, Barber G C. Engagement of a rough, lubricated and grooved disk clutch with a porous deformable paper-based friction material. *Tribol Trans* **45**(4): 464–470 (2002)
- [11] Zagrodzki P. Thermoelastic instability in friction clutches and brakes-transient modal analysis revealing mechanisms of excitation of unstable modes. *Int J Solids Struct* **46**(11–12): 2463–2476 (2009)
- [12] Shahzamanian M M, Sahari B B, Bayat M, Ismarrubie Z N, Mustapha F. Transient and thermal contact analysis for the elastic behavior of functionally graded brake disks due to mechanical and thermal loads. *J Mater Design* **31**(10): 4655–4665 (2010)
- [13] Gao C H, Lin X Z. Transient temperature field analysis of a brake in a non-axisymmetric three dimensional model. *J Mater Process Tech* **129**(1–3): 513–517 (2002)
- [14] Ingram M, Noles J, Watts R, Harris S, Spikes H A. Frictional properties of automatic transmission fluids: Part II-origins of friction-sliding speed behavior. *Tribol Trans* **54**(1): 154–167 (2010)
- [15] Al-Shabibi A M. Transient behavior of initial perturbation in multidisk clutch system. *Tribol Trans* **57**(6): 1164–1171 (2014)
- [16] Wriggers P, Miehe C. Contact constraints within coupled thermomechanical analysis-a finite element model. *J Comput Meth Appl Mech Eng* **113**(3): 301–319 (1994)
- [17] ANSYS Inc. ANSYS Contact Technology Guide, ANSYS Release 14.0 Documentation.
- [18] Mohr G A. A contact stiffness matrix for finite element problems involving external elastic restraint. *J Comput Struct* **12**(2): 189–191 (1980)



Josef SCHLATTMANN. He is a univ.-professor at the Hamburg University of Technology in the field of systems technology and product development methodology. The fields of his research are systematically

product development of machine elements and/or machine systems; tribology investigations; development of an autonomous biped robot, e.g., path planning, optimization of the control and the mechanical units; cooperation research work with the German industry.



Oday Ibraheem ABDULLAH. He received his Ph.D. degree in mechanical engineering from Hamburg University of Technology in 2015. He is one of the faculty members in the Department of Energy Engineering/College of Engineering/

University of Baghdad since 2002. Now he is a research associate in System Technology and Mechanical Design Methodology Group/Hamburg University of Technology. His research areas cover the tribology, stress analysis, vibration analysis, and thermal analysis.

