

Review of Design Flexural Strengths of Steel–Concrete Composite Beams for Building Structures

Lan Chung¹⁾, Jong-Jin Lim¹⁾, Hyeon-Jong Hwang²⁾, and Tae-Sung Eom^{1),*}

(Received March 21, 2016, Accepted May 1, 2016, Published online May 19, 2016)

Abstract: Recently, as the use of high-performance materials and complex composite methods has increased, the need for advanced design specifications for steel–concrete composite structures has grown. In this study, various design provisions for ultimate flexural strengths of composite beams were reviewed. Design provisions reviewed included the load and resistance factor design method of AISC 360-10 and the partial factor methods of KSSC–KCI, Eurocode 4 and JSCE 2009. The design moment strengths of composite beams were calculated according to each design specification and the variation of the calculated strengths with design variables was investigated. Furthermore, the relationships between the deformation capacity and resistance factor for flexure were examined quantitatively. Results showed that the design strength and resistance factor for flexure of composite beams were substantially affected by the design formats and variables.

Keywords: composite beam, flexural strength, partial factor method, load and resistance factor method, composite structure.

1. Introduction

In Korea, the design of steel–concrete composite members for building structures has been conventionally addressed in a section of the design code for steel structures, KBC 2014 Sec. 0709 (Architectural Institute of Korea 2014). However, as the use of high performance materials and complex composite methods has increased, the need for a more advanced design code for composite members and structures is growing. For this, joint research to develop an independent design code for composite structures was performed by the Korean Society of Steel Construction (KSSC)–Korean Concrete Institute (KCI) joint composite structure committee (KSSC–KCI Joint Composite Structure Committee 2014). By reviewing existing design standards and recent studies, the KSSC–KCI joint research was aimed at developing a performance-based design code to accommodate high-strength materials and new composite systems.

According to the review of existing design standards, such as AISC 360-10 (American Institute of Steel Construction 2010), KBC 2014 (Architectural Institute of Korea 2014), Eurocode 4 (European Committee for Standardization 2004a), and JSCE 2009 (Japan Society of Civil Engineers 2009), the calculation methods for design strengths of steel–

concrete composite members can be divided into the load and resistance factor design method (LRFD) and the partial factor method (PFM). For AISC 360-10 and KBC 2014, using LRFD, the design strength of a composite member is determined by multiplying the nominal member strength and the resistance factor ϕ , which is not greater than 1.0. For Eurocode 4 and JSCE 2009, adopting PFM, in contrast, the partial safety factor γ of not less than 1.0 is applied directly to material characteristic strengths rather than to the member strength. This difference in the calculation format between the LRFD and PFM can result in significant differences in the design strength of composite members, even though the material and section properties are the same. Furthermore, by using a safety factor at the material level, rather than at the member level, PFM may be more flexible in accommodating high-strength materials and new composite methods.

In this study, the provisions for flexural design of composite beams specified in AISC 360-10, KBC 2014, Eurocode 4, and JSCE 2009 were reviewed in terms of design format, resistance and safety factors, and the method of section analysis. For a quantitative comparison, the design moment strength of fully composite beams was calculated according to the provisions specified in each design code. Then, the variation of the calculated strengths with design variables (steel yield strength, concrete strength, and effective width of concrete slab) was investigated. Furthermore, the relationships between the deformation capacity and resistance factor for flexure were analyzed quantitatively. Particular attention was given to the applicability of 800 MPa grade high-strength steel to composite beams, which was included in KBC 2014 (Architectural Institute of Korea 2014).

¹⁾Department of Architectural Engineering, Dankook University, Yongin-si 448-701, Gyeonggi-do, Korea.

*Corresponding Author; E-mail: tseom@dankook.ac.kr

²⁾College of Civil Engineering, Hunan University, Yuelu Mountain, Changsha 410082, Hunan, China.

2. Provisions for Flexural Design

2.1 Design Format and Material Strength

Table 1 compares the design formats and material strengths specified in AISC 360-10, KBC 2014, Eurocode 4, and JSCE 2009. In the table, the characteristic strength, design strength, and safety factor for materials are denoted as $f_k, f_d (=f_k/\gamma)$, and γ , respectively. For example, f_{ck}, f_{cd} , and γ_c are the characteristic compressive strength, design compressive strength, and safety factor for concrete, F_{yk}, F_{yd} , and γ_s are the characteristic yield strength, design yield strength, and safety factor for structural steel, and f_{yrk}, f_{yrd} , and γ_r are the values for reinforcing steel bars. Additionally, $M(f_k)$ and $M(f_d)$ denote the ultimate moment strengths of composite beams calculated by using the characteristic and design material strengths, f_k and f_d , respectively. In table 1 M_d is the design moment strength including a safety margin against the nominal strength, and ϕ is the resistance factor used for LRFD.

For AISC 360-10 and KBC 2014, which use LRFD as the design format, the design moment strength of composite beams is calculated by multiplying the nominal strength $M(f_k)$ and resistance factor $\phi (=0.9)$: $M_d = \phi M(f_k)$. Thus, the LRFD can ensure a constant safety margin for bending, regardless of the behavior of composite beams. For Eurocode 4, which uses PFM as its design format, in contrast, the design moment strength is directly calculated from the reduced material strengths f_d divided by the partial safety factors for concrete, steel, and reinforcing bar (i.e., $\gamma_c = 1.5$, $\gamma_s = 1.0$, and $\gamma_r = 1.15$): $M_d = M(f_d)$. Thus, the safety margin for bending of composite beams designed by PFM is affected substantially by their behavior (this will be discussed in detail later, in the Sect. 5). In JSCE 2009, on the other hand, a safety factor for member $\gamma_b (=1.1)$ addressing the effects of accuracy in section analysis/design, variations in member size, and the importance of the role of the member, is used along with the safety factors for materials (i.e. $\gamma_c = 1.3$, $\gamma_s = 1.0$, and $\gamma_r = 1.0$; see Table 1). The design moment strength is determined as $M_d = M(f_d)/\gamma_b$. Because $1/\gamma_b$ can be considered as a resistance factor for

bending, the design format of JSCE 2009 can be seen as a mixed form of PFM and LRFD.

Table 1 also shows the upper and lower limits on characteristic strengths of materials specified in each design code. The upper limit of the compressive strength of concrete is generally similar to $f_{ck} = 60\text{--}80$ MPa in all design codes. On the other hand, AISC 360-10 and KBC 2014 allow the use of relatively high-strength steels ($F_{yk} = 525$ and 650 MPa). In particular, KBC 2014 has increased the upper limit of steel yield strength as $F_{yk} = 650$ MPa, based on recent studies (Kim et al. 2012a, b, 2014; Lee et al. 2012, 2013a, b, c, 2014; Youn 2013a).

2.2 Design Moment Strength

The ultimate moment strength of composite beam sections can be calculated using the plastic stress distribution method (PSDM) and strain-compatibility method (SCM). Table 2 compares stress distributions of concrete, steel, and reinforcing bars over a composite section required for the PSDM prescribed in each design code. The stress distributions illustrated in Table 2 are for positive bending, where the concrete flange is subjected to compression. For AISC 360-10 and KBC 2014 that use LRFD as their design format, the plastic stresses of concrete, steel, and reinforcing bars are defined as $0.85f_{ck}$, F_{yk} , and f_{yrk} , respectively. The plastic moment M_{pl} and the depth D_p of plastic neutral axis are then calculated from the force equilibrium between internal resultant forces produced by the plastic stresses $0.85f_{ck}$, F_{yk} , and f_{yrk} . On the other hand, Eurocode 4 and JSCE 2009 adopting PFM as the design format define the design plastic stresses of concrete, steel, and reinforcing bars as $0.85f_{cd}$, F_{yd} , and f_{yrd} , respectively. Because the design plastic stresses are decreased by dividing by the safety factors γ_c , γ_s , and γ_r (≥ 1.0), the values of M_{pl} and D_p determined from PSDM specified in Eurocode 4 and JSCE 2009 are not equivalent to those of AISC 360-10 and KBC 2014.

In fact, the plastic stress distributions shown in Table 2 are different from the actual stress distributions at the ultimate limit state. Furthermore, a composite beam may suffer a premature failure due to crushing failure in the concrete slab

Table 1 Design format and material strength of existing specifications.

	AISC 360-10	KBC 2014	Eurocode 4	JSCE 2009
Design format	Load and resistance factor design	Load and resistance factor design	Partial factor method	Partial factor method
Design moment strength M_d	$M_d = \phi M(f_k)$	$M_d = \phi M(f_k)$	$f_d = f_k/\gamma$ and $M_d = M(f_d)$	$f_d = f_k/\gamma$ and $M_d = M(f_d)/\gamma_b^{(1)}$
Resistance factor ϕ or Safety factor γ for materials	$\phi = 0.9$	$\phi = 0.9$	Concrete $\gamma_c = 1.5$ Steel $\gamma_s = 1.0^{(2)}$ Reinforcing bar $\gamma_r = 1.15$	Concrete $\gamma_c = 1.3$ Steel $\gamma_s = 1.0$ Reinforcing bar $\gamma_r = 1.0$
Characteristic material strength f_k (MPa)	Concrete $21 \leq f_{ck} \leq 70$ Steel $F_{yk} \leq 525$	Concrete $21 \leq f_{ck} \leq 70$ Steel $F_{yk} \leq 650$	Concrete $20 \leq f_{ck} \leq 60$ Steel $F_{yk} \leq 460$	Concrete $18 \leq f_{ck} \leq 80$ Steel $-^{(3)}$

⁽¹⁾ Partial safety factor for members $\gamma_b = 1.1$.

⁽²⁾ $\gamma_s = 1.0$ is used for yielding.

⁽³⁾ Although steel strength limitation is not specified, $F_{yk} \leq 450$ MPa is generally accepted.

Table 2 Design moment strengths by plastic stress distribution method and strain compatibility method.

	AISC 360-10 and KBC 2014	Eurocode 4	JSCE 2009
PSDM ⁽¹⁾			
Plastic stress	Conc. $0.85f_{ck}$, steel F_{yk} , and reinforcing bar f_{yrk}	Conc. $0.85f_{cd}$, steel F_{yd} , and reinforcing bar f_{yrd}	Conc. $0.85f_{cd}$, steel F_{yd} , and reinforcing bar f_{yrd}
Stress distribution	<p style="text-align: center;">Positive bending</p>		
Design strength M_d	$M_d = \phi M_{pl}$ and $\phi = 0.9$	$M_d = M_{pl}$ or $\beta M_{pl}^{(2)}$	$M_d = M_{pl}/\gamma_b$ and $\gamma_b = 1.1$
SCM ⁽¹⁾			
Conc. σ - ϵ curve	Not specified ⁽³⁾ Maximum compressive strain = 0.003	Parabola-rectangle ⁽⁴⁾	Parabola-rectangle ⁽⁵⁾
Steel σ - ϵ curve	Not specified ⁽³⁾	Elastic-perfectly plastic	Bilinear with $0.01E_s$ hardening
Stress and strain distributions (positive bending)	<p style="text-align: center;">Positive bending</p> <p style="text-align: center;">AISC 360-10</p>	<p style="text-align: center;">EC4</p>	<p style="text-align: center;">JSCE 2009</p>
Design strength M_d	$M_d = \phi M_{nl}$ and $\phi = 0.9$	$M_d = M_{nl}$	$M_d = M_{nl}/\gamma_b$ and $\gamma_b = 1.1$

⁽¹⁾ PSDM plastic stress distribution method, SCM strain compatibility method.

⁽²⁾ β is the reduction factor for high strength steels of 420 and 460 MPa. β is used for positive moment only.

⁽³⁾ The σ - ϵ relationships of concrete and steel shall be obtained from tests or from published results for similar materials.

⁽⁴⁾ The σ - ϵ relationship is given in Eurocode 2 (European Committee for Standardization 2004b). The bilinear relationship is also available.

⁽⁵⁾ The σ - ϵ relationship is given in JSCE 2007 (Japan Society of Civil Engineers 2007) ($k_1 = 1 - 0.003f_{ck}$).

even before the plastic stress is fully developed in the steel section. This is more likely to occur when high-strength steel is used. Thus, to secure a relatively greater margin of safety, Eurocode 4 requires the design moment strength M_d of the composite beam under positive bending be modified as $M_d = \beta M_{pl}$ by multiplying by a reduction factor β (≤ 1.0) (see Table 2). The reduction factor β is applied only when high-strength steels of $F_{yk} = 420$ and 460 MPa are used. Figure 1 shows the reduction factor β specified in Eurocode 4. If $D_p/D_t \leq 0.15$, $\beta = 1.0$ is applied and thus the moment strength calculated by the PSDM is not reduced ($D_t =$ overall depth of composite section); if $0.15 < D_p/D_t$

$D_t \leq 0.4$, then β decreases linearly, from 1.0 to 0.85. The PSDM should not be used for $D_p/D_t > 0.4$ because a brittle failure of the composite beam can occur as a result of early crushing in the concrete slab.

The reduction factor β is also used in the AASHTO LRFD bridge design specification (American Association of State Highway and Transportation Officials 2012; Wittry 1993). As shown in Fig. 1, β specified in AASHTO LRFD 2012 decreases from 1.0 to 0.78 as the ratio of D_p/D_t increases from 0.1 to 0.42. The reduction factor β specified in AASHTO LRFD 2012 is applied to steels of all strength grades of $F_{yk} = 485$ MPa or less, while the β specified in

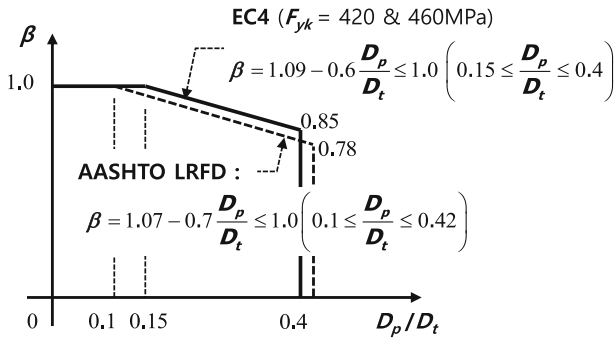

Fig. 1 Reduction factor β for plastic moment strength under positive bending: Eurocode 4 and AASHTO LRFD 2005.

Eurocode 4 is applied only to high-strength steels of $F_{yk} = 420$ and 460 MPa. AISC 360-10, KBC 2014, and JSCE 2009 do not define a reduction factor β for the plastic moment determined from the PSDM.

The stress and strain distributions at the ultimate limit state for the design of a cross section by the SCM are also shown in Table 2 (European Committee for Standardization 2004b; Japan Society of Civil Engineers 2007). Linear strain distribution along the height of the composite section is assumed in all design codes. However, the maximum compressive strain ϵ_{cu} of concrete varies: AISC 360-10 and KBC 2014 use a constant value of $\epsilon_{cu} = 0.003$, while Eurocode 4 and JSCE 2009 define a varying $\epsilon_{cu} = 0.0025$ – 0.0035 , according to the characteristic compressive strength f_{ck} of concrete [refer to notes (4) and (5) of Table 2]. In the SCM, the stresses of concrete, steel, and reinforcing bars corresponding to the linear strain distribution are basically determined by the stress–strain relationship of each material. Eurocode 4 prescribes the bilinear, parabolic-rectangle, and rectangular stress distributions for concrete specified in Eurocode 2 (European Committee for Standardization 2004b). JSCE 2009 is similar to Eurocode 4. In contrast, AISC 360-10 and KBC 2014 allow the use of the relationship obtained from tests or from published results for similar materials, without providing a specific stress–strain relationship for concrete. For steel, bilinear relationships without hardening and with hardening are allowed for Eurocode 4 and JSCE 2009, respectively. For AISC 360-10 and KBC 2014, however, any stress–strain relationship obtained from tests or from published results for similar materials can be used.

In the SCM, the nonlinear moment strength M_{nl} is obtained by integrating the stresses and forces of concrete, steel, and reinforcing bars over the cross-section. For AISC 360-10 and KBC 2014 that use LRFD as their design format, the design moment strength of the cross-section is determined as $M_d = \phi M_{nl}$, by multiplying by the resistance factor ϕ ($=0.9$). For Eurocode 4 that uses PFM as its design format, in contrast, the design moment strength is determined as $M_d = M_{nl}$ because a safety margin is already addressed in the design strength of materials. JSCE 2009 defines the design moment strength as $M_d = M_{nl}/\gamma_b$ by dividing M_{nl} by the safety factor for the member.

3. KSSC–KCI Provisions for Flexural Design

The KSSC–KCI joint composite structure committee developed a draft version of a performance-based design specification for composite structures, KSSC–KCI (KSSC–KCI Joint Composite Structure Committee 2014). KSSC–KCI adopted PFM as a design format. Thus, the design strengths of concrete, steel, and reinforcing bars (f_{cd} , F_{yd} , and f_{yrd} , respectively) are defined using the resistance factors for materials, as follows.

$$f_{cd} = \phi_c f_{ck} \quad (1a)$$

$$F_{yd} = \phi_s F_{yk} \quad (1b)$$

$$f_{yrd} = \phi_r f_{yrk} \quad (1c)$$

where, ϕ_c , ϕ_s , and ϕ_r , respectively, are the resistance factors for concrete, steel, and reinforcing bars. In KSSC–KCI, the resistance factors were defined as $\phi_c = 0.65$, $\phi_s = 1.0$, and $\phi_r = 0.9$.

Basically, the moment strength for the design of cross sections can be calculated from PSDM and SCM. In the case of the PSDM, first, the plastic moment M_{pl} and the depth D_p of plastic neutral axis are calculated using the plastic stresses at the ultimate limit state, such as $0.85f_{cd}$ ($=0.85\phi_c f_{ck}$) for concrete, F_{yd} ($=\phi_s F_{yk}$) for steel, and f_{yrd} ($=\phi_r f_{yrk}$) for reinforcing bars. The design moment strength of the cross section is determined as $M_d = M_{pl}$ and βM_{pl} for positive and negative bending, respectively. In KSSC–KCI, the reduction factor β (≤ 1.0) is defined as follows on the basis of Youn’s study (Youn 2013b) (see Fig. 2).

$$\beta = 1.045 - 0.375 \left(\frac{D_p}{D_t} \right) \quad \text{for } F_{yk} = 450 \text{ MPa or less} \quad (2a)$$

$$\beta = 1.066 - 0.550 \left(\frac{D_p}{D_t} \right) \quad \text{for } F_{yk} = 650 \text{ MPa} \quad (2b)$$

In Eqs. (2a) and (2b), D_p/D_t should not be greater than 0.42. If $D_p/D_t > 0.42$, the PSDM cannot be used for the design of cross sections. Similar to AASHTO LRFD 2012,

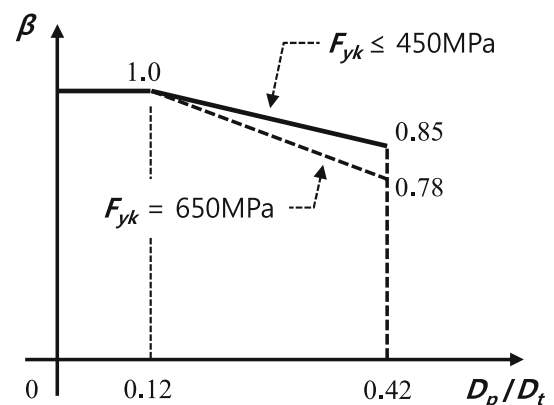

Fig. 2 Reduction factor β for plastic moment strength under positive bending: KSSC–KCI 2014.

KSSC–KCI requires the reduction factor β be applied to steels of all strength grades of $F_{yk} = 650$ MPa or less. However, to secure a greater margin of safety for high-strength steels of $F_{yk} = 650$ MPa, a relatively smaller value of β is defined, as shown in Eq. (2b) and Fig. 2. The values of β corresponding to each strength grade of steel are given in detail in Youn’s study (2013).

KSSC–KCI also allows the use of SCM for the design of composite cross sections. For the strain-compatible section analysis, a linear strain distribution over the cross section is assumed, as illustrated in Table 2. The stress–strain relationship of concrete including the ultimate compressive strain ε_{cu} is defined as follows (see Fig. 3).

$$\sigma_c = f_{cd} \left[1 - \left(1 - \frac{\varepsilon_c}{\varepsilon_{co}} \right)^n \right] \quad \text{for } 0 \leq \varepsilon_c \leq \varepsilon_{co} \quad (3a)$$

$$\sigma_c = f_{cd} \quad \text{for } \varepsilon_{co} \leq \varepsilon_c \leq \varepsilon_{cu} \quad (3b)$$

where, σ_c and ε_c = compressive stress and strain of concrete, respectively, n = an exponent determining the shape of ascending parabola, ε_{co} = strain at the peak stress ($=f_{cd}$), and ε_{cu} = ultimate compressive strain at failure.

$$n = 2.0 - \left(\frac{f_{ck} - 40}{100} \right) \leq 2.0 \quad (4)$$

$$\varepsilon_{co} = 0.002 + \left(\frac{f_{ck} - 40}{100000} \right) \geq 0.002 \quad (5)$$

$$\varepsilon_{cu} = 0.0033 - \left(\frac{f_{ck} - 40}{100000} \right) \leq 0.0033 \quad (6)$$

The stress distribution and ultimate strain (ε_{cu}) of concrete can have substantial effects on design results, particularly when high-strength steel is used and the cross section is under positive bending. Thus, the σ_c – ε_c relationship of concrete is specified in KSSC–KCI so that engineers can use the SCM with convenience for the design of cross sections.

For steel sections, KSSC–KCI allows the use of a bilinear stress–strain relationship, representing the elastic-perfectly plastic or strain-hardening behavior. For reinforcing bars, in contrast, only an elastic-perfectly plastic model is allowed. Such bilinear models of steel and reinforcing bars are used for the strain-compatible section analysis of composite sections in conjunction with the linear strain distribution.

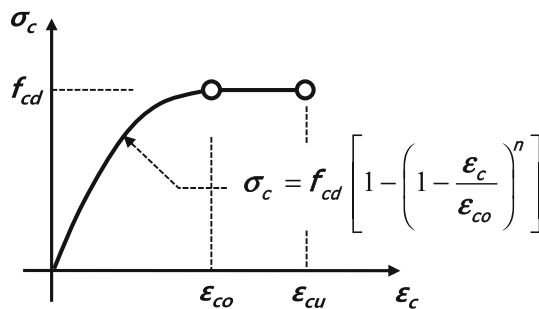

Fig. 3 Stress–strain relationship of concrete for section design.

4. Design Resistance by Plastic Stress Distribution Method

In this section, the design moment strength of cross sections calculated by the PSDM specified in KSSC–KCI, AISC 360-10 (or KBC 2014), Eurocode 4, and JSCE 2009 were compared. For KBC 2014, the design format, resistance factor, and plastic stresses of the materials are the same as those of AISC 360-10 (refer to Tables 1 and 2). Figure 4 shows the cross sections of interior and exterior composite beams used for the study. The sectional properties of interior and exterior composite beams were equivalent except for the effective widths b_{eff} of the concrete slabs. The overall height and flange width of the steel section were 600 and 200 mm, respectively, and the thicknesses of the web and flange were 11 and 17 mm, respectively. The overall and net thicknesses of the concrete slabs were 150 and 95 mm, respectively. The effective widths of the concrete slabs were $b_{eff} = 2400$ and 1000 mm for the interior and exterior beams, respectively. In the calculation of design moment strengths, the reinforcement of concrete slabs ($A_s = 1980$ and 824 mm²) was ignored.

In this study, $f_{ck} = 21$ and 30 MPa were considered as the characteristic compressive strength of concrete. For the steel section, $F_{yk} = 235, 315, 355, 450,$ and 650 MPa were considered as the characteristic yield strengths. Such yield strengths are the same as those of weldable structural steel specified in KSSC–KCI and KBC 2014.

4.1 Positive Bending

Tables 3 and 4, respectively, show the design moment strengths M_d of the interior and exterior composite beams under positive bending, calculated by the PSDM specified in each design code. M_d includes the effects of the resistance factor (ϕ) or the safety factor for materials ($\gamma_c, \gamma_s,$ and γ_r or $\phi_c, \phi_s,$ and ϕ_r) [refer to Table 2 and note (1) of Tables 3 and 4]. Because Eurocode 4 and JSCE 2009 do not allow the use of a high-strength steel of $F_{yk} = 650$ MPa, M_d corresponding to $F_{yk} = 650$ MPa was not calculated in the tables [refer to note (3) of Tables 3 and 4]. Although AISC 360-10 is also not applicable to $F_{yk} = 650$ MPa, M_d calculated according to AISC 360-10 is given for a comparison to KSSC–KCI. Additionally, the PSDM specified in KSSC–KCI and Eurocode 4 was applied only for $D_p/D_t \leq 0.4$ and $D_p/D_t \leq 0.42$, respectively [refer to note (4) of Table 4].

Figures 5 and 6 show the variation of the design strengths M_d by KSSC–KCI, Eurocode 4, and JSCE 2009 according to steel yield strengths F_{yk} ($=235, 315, 355, 450,$ and 650 MPa). The vertical and horizontal axes indicate the ratio of design strengths (i.e., $M_d/M_{pl,AISC}$) and the characteristic yield strength F_{yk} of steel, respectively. The variation of $M_d/M_{pl,AISC}$ for the interior and exterior beams are presented in Figs. 5 and 6, respectively. It is noted that, for comparisons between comparable design codes, the design strengths M_d of KSSC–KCI, Eurocode 4, and JSCE 2009 were divided by the nominal strength $M_{pl,AISC}$ of AISC 360-10 (see M_{pl} of Table 3). If all safety and resistance factors for materials are

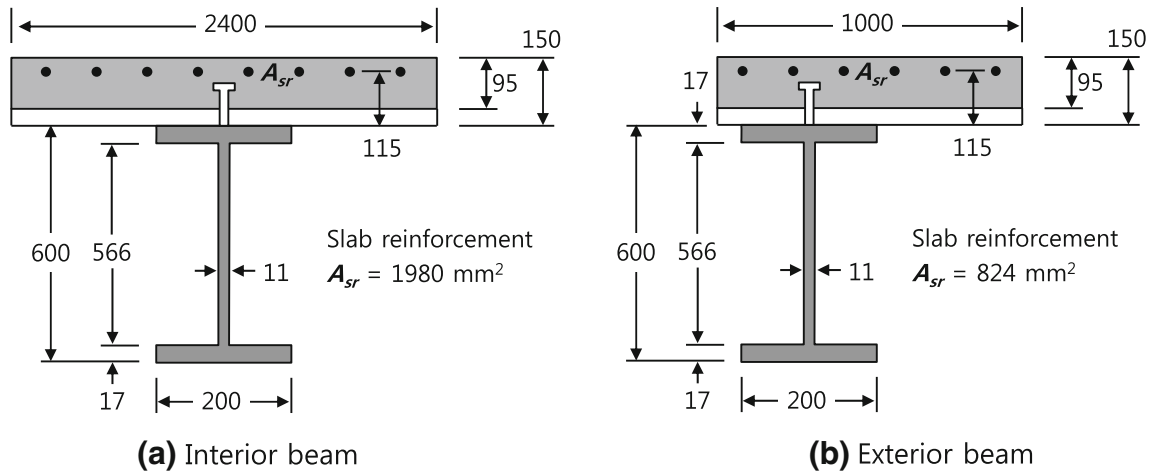

Fig. 4 Cross sections of composite beams (mm).

Table 3 Design results calculated by PSDM: interior beams under positive bending (kN m).

f_{ck} (MPa)	F_{yk} (MPa)	AISC 360-10		KSSC-KCI		Eurocode 4		JSCE 2009
		M_{pl}	$M_d^{(1)}$	β	$M_d^{(1)}$	β	$M_d^{(1)}$	$M_d^{(1)}$
21	235	1268	1141	0.957	1138	— ⁽²⁾	1196	1123
	315	1648	1483	0.952	1422	— ⁽²⁾	1501	1407
	355	1803	1623	0.951	1564	— ⁽²⁾	1653	1545
	450	2167	1950	0.934	1868	0.949	1907	1871
	650	2920	2628	0.782	2097	— ⁽³⁾	— ⁽³⁾	— ⁽³⁾
30	235	1301	1171	1.000	1287	— ⁽²⁾	1293	1203
	315	1709	1538	0.958	1550	— ⁽²⁾	1628	1516
	355	1907	1716	0.956	1694	— ⁽²⁾	1783	1677
	450	2354	2119	0.949	2025	0.961	2062	2010
	650	3122	2810	0.881	2539	— ⁽³⁾	— ⁽³⁾	— ⁽³⁾

⁽¹⁾ $M_d = \phi M_{pl}$ for AISC 360-10 (or KBC 2014), M_{pl} or βM_{pl} for Eurocode 4, βM_{pl} for KSSC-KCI 2014, and M_{pl}/γ_b for JSCE 2009.

⁽²⁾ For Eurocode 4, β shall be applied for high strength steel of $F_{yk} = 420$ and 460 MPa.

⁽³⁾ For Eurocode 4 and JSCE 2009, the plastic stress distribution method shall not be applied for $F_{yk} = 650$ MPa.

ignored (i.e., assumed to be 1.0), the nominal plastic moment strengths calculated from KSSC-KCI, Eurocode 4, and JSCE 2009 are the same as that of AISC 360-10, $M_{pl,AISC}$. In this regard, $M_d/M_{pl,AISC}$, shown in Figs. 5 and 6, reflects not only the difference in design moment strengths between design codes but also the variation of the resistance factor for bending ($=\phi$) of each design code, depending on the design variables, such as F_{yk} , f_{ck} , and b_{eff} .

As shown in Figs. 5 and 6, $M_d/M_{pl,AISC}$ of KSSC-KCI and Eurocode 4 showed decreasing trends as F_{yk} was increased from 235 to 650 MPa. Additionally, $M_d/M_{pl,AISC}$ for a lower concrete strength of $f_{ck} = 21$ MPa was mostly less than that for a higher concrete strength of $f_{ck} = 30$ MPa. $M_d/M_{pl,AISC}$ of the exterior beam with a narrower concrete flange ($b_{eff} = 1000$ mm) was mostly less than those of the interior beam with a wider concrete flange ($b_{eff} = 2400$ mm). Such trends of $M_d/M_{pl,AISC}$ with respect to F_{yk} , f_{ck} , and b_{eff} show that the design strength of the cross sections and the resistance factor for bending under positive bending are affected

substantially by the compression resistance of the concrete flange. That is, the greater F_{yk} of the steel section and the smaller f_{ck} and b_{eff} of the concrete flange made the depth D_p of the plastic neutral axis greater, which, in turn, resulted in increasing the contribution of the concrete flange to M_d . Because KSSC-KCI and Eurocode 4 define relatively higher resistance and safety factors for concrete (i.e. $\phi_c = 0.65$ and $\gamma_c = 1.5$, respectively), the safety margin for bending of the design strength increased along with the increased contribution of the concrete flange. In contrast, AISC 360-10 defines a constant resistance factor $\phi (=0.9)$ for bending regardless of material and section properties. As a result, $M_d/M_{pl,AISC}$ (or the resistance factor ϕ for bending) of KSSC-KCI and Eurocode 4 showed decreasing trends with respect to F_{yk} , f_{ck} , and b_{eff} in Figs. 5 and 6.

For KSSC-KCI and Eurocode 4, the reduction factor β , defined as a function of D_p/D_t , also affected the decreasing trends of $M_d/M_{pl,AISC}$ (or the resistance factor ϕ for bending). In particular, KSSC-KCI requires β be applied to steels of

Table 4 Design results calculated from PSDM: exterior beams under positive bending (kN m).

f_{ck} (MPa)	F_{yk} (MPa)	AISC 360-10		KSSC-KCI		Eurocode 4		JSCE 2009
		M_{pl}	$M_d^{(1)}$	β	$M_d^{(1)}$	β	$M_d^{(1)}$	$M_d^{(1)}$
21	235	1082	974	0.901	907	— ⁽²⁾	1004	939
	315	1377	1239	0.866	1089	— ⁽²⁾	1265	1185
	355	1514	1363	0.854	1181	— ⁽⁴⁾	— ⁽⁴⁾	1302
	450	1826	1643	— ⁽⁴⁾	— ⁽⁴⁾	— ⁽⁴⁾	— ⁽⁴⁾	1570
	650	2443	2199	— ⁽⁴⁾	— ⁽⁴⁾	— ⁽³⁾	— ⁽³⁾	— ⁽³⁾
30	235	1164	1048	0.949	1014	— ⁽²⁾	1073	1001
	315	1468	1321	0.911	1237	— ⁽²⁾	1364	1274
	355	1619	1457	0.894	1334	— ⁽²⁾	1499	1403
	450	1967	1770	0.866	1556	0.861	1555	1693
	650	2631	2368	— ⁽⁴⁾	— ⁽⁴⁾	— ⁽³⁾	— ⁽³⁾	— ⁽³⁾

- (1) $M_d = \phi M_{pl}$ for AISC 360-10 (or KBC 2014), M_{pl} or βM_{pl} for Eurocode 4, βM_{pl} for KSSC-KCI 2014, and M_{pl}/γ_b for JSCE 2009.
 (2) For Eurocode 4, β shall be applied for high strength steel of $F_{yk} = 420$ and 460 MPa.
 (3) For Eurocode 4 and JSCE 2009, the plastic stress distribution method shall not be applied for $F_{yk} = 650$ MPa.
 (4) The use of the plastic stress distribution method is restrained for $D_p/D_t \leq 0.4$ for Eurocode 4 and $D_p/D_t \leq 0.42$ for KSSC-KCI.

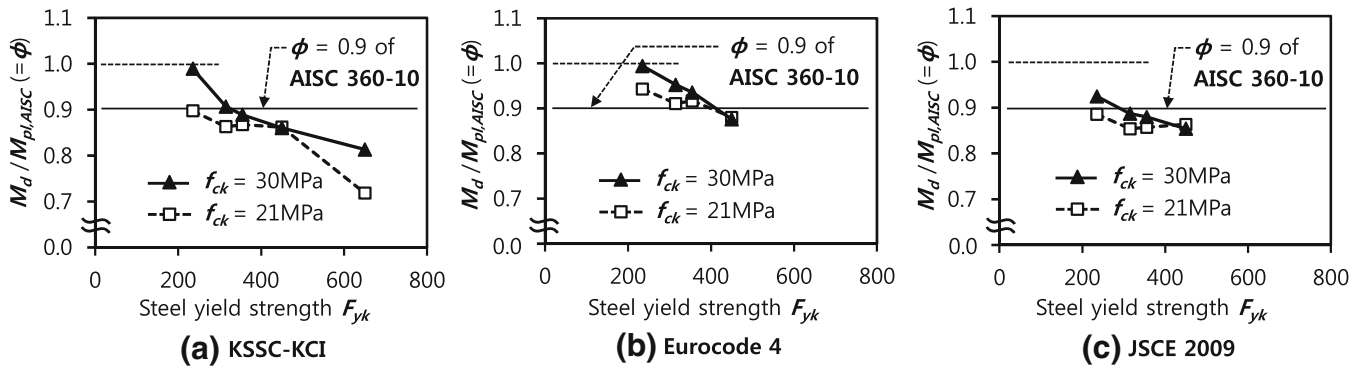

Fig. 5 Comparison of design strengths calculated from PSDM: interior beam under positive moment.

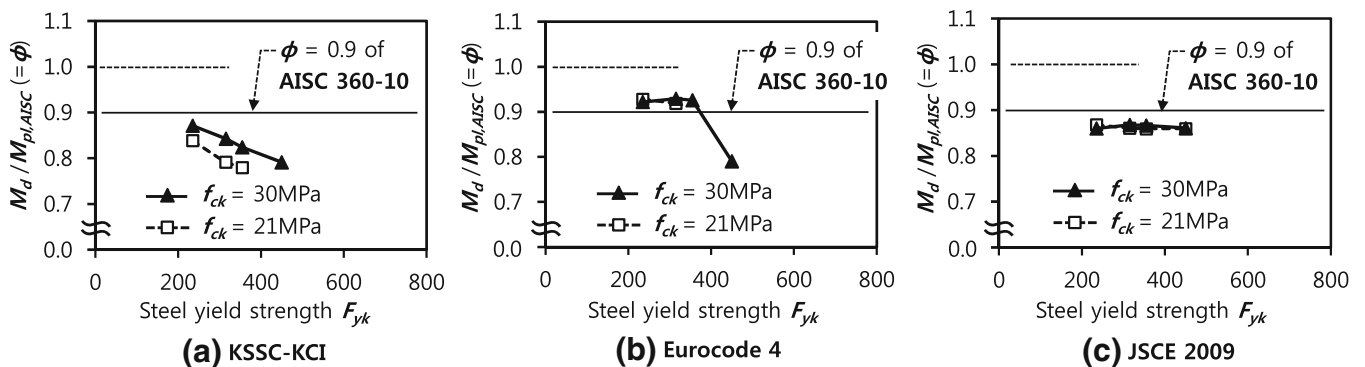

Fig. 6 Comparison of design strengths calculated from PSDM: exterior beam under positive moment.

all strength grades between $F_{yk} = 235$ and 650 MPa, while Eurocode 4 does not apply β to normal strength steels of $F_{yk} = 235$ – 355 MPa (see Fig. 2; Table 2). Thus, the decreasing trend of $M_d/M_{pl,AISC}$ was steeper in KSSC-KCI than in Eurocode 4.

For JSCE 2009 where the design format is a mixed form of PFM and LRFD, as shown in Figs. 5c and 6c, the

variation of $M_d/M_{pl,AISC}$ (or the resistance factor ϕ for bending) according to the design variables, such as F_{yk} , f_{ck} , and b_{eff} , was not as significant as those of KSSC-KCI and Eurocode 4. Because the safety factor for member ($\gamma_b = 1.1$) acting as a resistance factor for bending had a significant impact on the design strengths, $M_d/M_{pl,AISC}$ (or ϕ) was almost constant regardless of F_{yk} , f_{ck} , and b_{eff} .

Figures 5 and 6 also compare the design strengths M_d of KSSC–KCI, Eurocode 4, and JSCE 2009 (PFM) with those of AISC 360-10 (LRFD). For AISC 360-10, the ratio of $M_d/M_{pl,AISC}$ is constant at 0.9, regardless of design variables. Therefore, if $M_d/M_{pl,AISC}$ of a design code is greater than 0.9, M_d of the design code is greater than that of AISC 360-10. The values of M_d calculated from Eurocode 4 were mostly greater than those of AISC 360-10, except for the cases of $F_{yk} = 420$ and 460 MPa. For KSSC–KCI, on the other hand, the values of M_d were mostly less than those of AISC 360-10, except for the interior beam with $F_{yk} = 235$ and 315 MPa. The averages of $M_d/M_{pl,AISC}$ were only 0.87 and 0.82 for the interior and exterior beams, respectively. Although the safety margins for materials specified in KSSC–KCI and Eurocode 4 were almost equivalent in magnitude, M_d of KSSC–KCI was reduced further even in $F_{yk} = 235, 315,$ and 355 MPa as a result of applying the reduction factor β to all strength grades of steel. JSCE 2009 also showed the values of M_d less than those of AISC 360-10.

4.2 Negative Bending

Table 5 compares the design moment strengths M_d of the interior and exterior composite beams under negative bending, calculated by the PSDM specified in each design code. Properties of the cross sections are shown in Fig. 4. In the calculation of M_d , the tensile stress of concrete was ignored but the effect of slab reinforcement ($f_{yrk} = 400$ MPa and $A_{sr} = 1980$ and 824 mm²) was included. Because of the effects of slab reinforcements, the values of M_d for the interior and exterior beams were slightly different (see Table 5). Figure 7 shows the variation of the design strengths M_d of KSSC–KCI, Eurocode 4, and JSCE 2009 according to steel yield strengths, F_{yk} . For comparisons between comparable design codes, the design strengths M_d of KSSC–KCI, Eurocode 4, and JSCE 2009 were divided by the nominal strength $M_{pl,AISC}$ of AISC 360-10 (see M_{pl} of Table 5). As discussed in the previous section, the ratio of

$M_d/M_{pl,AISC}$ is equivalent to the resistance factor for bending ($=\phi$) of each design code.

For KSSC–KCI and Eurocode 4, $M_d/M_{pl,AISC}$ was 1.0 regardless of material and section properties, such as $F_{yk}, f_{ck},$ and b_{eff} . Thus, KSSC–KCI and Eurocode 4 had a constant resistance factor for bending of $\phi = 1.0$. This is because M_d under negative bending was governed by the steel section, rather than the concrete flange. KSSC–KCI and Eurocode 4 that use PFM as their design format do not define any safety margin for steel (i.e., $\phi_s = 1.0$ and $\gamma_s = 1.0$, respectively). In contrast, AISC 360-10 uses the resistance factor $\phi (=0.9)$ for bending. For JSCE 2009, $M_d/M_{pl,AISC} (= \phi)$ was slightly less than 0.9 as the result of dividing by the member safety factor $\gamma_b (=1.1)$, though the safety factor for steel was $\gamma_s = 1.0$.

As shown in Fig. 7, the design strengths M_d of KSSC–KCI and Eurocode 4 were about 10 % greater than those of AISC 360-10. For moment-resisting frame structures, the negative moment of composite beams at both ends are generally greater than the positive moment at the mid-span because lateral and gravity load effects are combined. Thus, from a practical view point, the greater M_d under negative bending of KSSC–KCI and Eurocode 4 can lead to a more economical design.

5. Design Resistance by Strain-Compatibility Method

5.1 Rotational Capacity and Resistance Factor for Bending

As discussed in the previous sections, AISC 360-10 that uses LRFD as its design format can secure a constant resistance factor for bending (i.e., $\phi = 0.9$), regardless of the rotational capacity of cross sections. For KSSC–KCI, Eurocode 4, and JSCE 2009 that use PFM as the design format, however, the resistance factor for bending may vary significantly according to design variables, such as the

Table 5 Design results calculated from PSDM: interior and exterior beams under negative bending (kN m).

Type	F_{yk} (MPa)	AISC 360-10		KSSC–KCI	Eurocode 4	JSCE 2009
		M_{pl}	$M_d^{(1)}$	$M_d^{(1)}$	$M_d^{(1)}$	$M_d^{(1)}$
Exterior beam	235	799	719	787	784	726
	315	1031	928	1019	1015	937
	355	1147	1032	1134	1130	1041
	450	1420	1278	1407	1403	1290
	650	1994	1795	1981	1977	1812
Interior beam	235	940	846	919	912	855
	315	1184	1066	1161	1153	1077
	355	1304	1174	1279	1272	1185
	450	1586	1427	1558	1550	1440
	650	2168	1951	2139	2130	1970

⁽¹⁾ $M_d = \phi M_{pl}$ for AISC 360-10 (or KBC 2014), M_{pl} for Eurocode 4 and KSSC–KCI, and M_{pl}/γ_b for JSCE 2009.

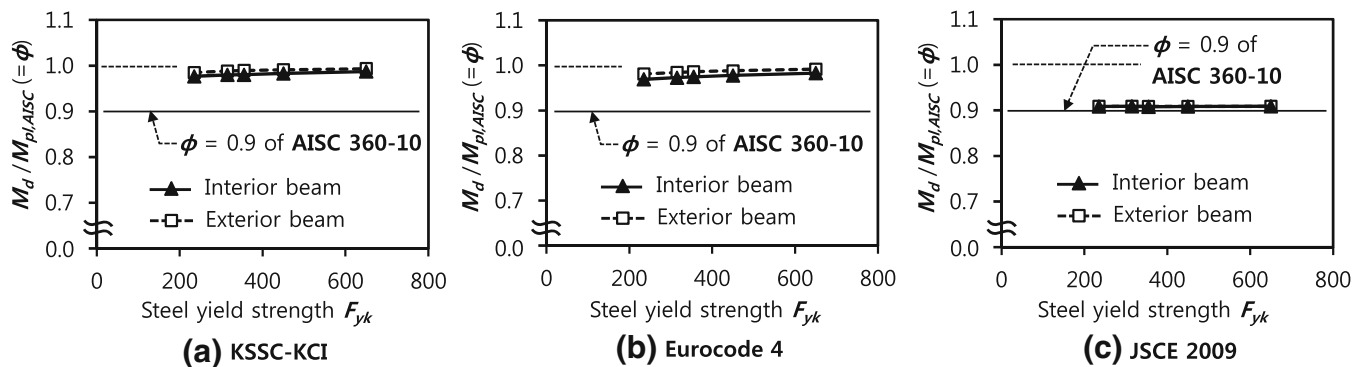

Fig. 7 Comparison of design strengths calculated from PSDM: interior and exterior beams under negative bending.

strength of materials and the geometry and rotational capacity of cross sections, because the margin of safety for bending is indirectly determined from the resistance or safety factor for each material. In this section, the quantitative relationship between the resistance factor for bending and the rotational capacity was investigated.

The investigation requires a strain-compatible section analysis addressing the stress–strain relationships of materials. For this, a fiber section analysis program to calculate the moment–curvature relationship of the cross section of composite members was developed. In the fiber section analysis, the cross section of a composite member is divided into a number of fiber elements with infinitesimal area and then internal forces of the steel section, concrete slab, and reinforcements are determined by integrating the infinitesimal stress and moment of each fiber element corresponding to strain. Figure 8 shows a typical moment–curvature relationship of the cross section of composite beams. For composite beams under positive bending, the ultimate limit state is defined as when the compressive strain of the extreme fiber of concrete slab reaches the ultimate strain ϵ_{cu} . The moment strength and curvature at the ultimate limit state are denoted as M_{nl} and κ_u , respectively (see Fig. 8). For KSSC–KCI, Eurocode 3, and JSCE 2009 that use PFM as their design format, the design moment strength M_d is determined as M_{nl} (KSSC–KCI and Eurocode 4) and M_{nl}/γ_b ($\gamma_b = 1.1$, JSCE 2009) (refer to Table 2).

For the cross section of a composite beam, the resistance factor for bending can be defined as M_d/M_k , where M_k is the nonlinear moment strength M_{nl} calculated from the fiber

section analysis using the characteristic strengths for materials f_k . Additionally, the rotational capacity can be quantified as the curvature ductility μ_d , determined by dividing the ultimate curvature κ_u by the yield curvature κ_y : $\mu_d = \kappa_u/\kappa_y$ (see Fig. 8). The yield curvature κ_y is defined from an idealized bilinear moment–curvature relationship constructed to pass through the point where the tensile flange of steel section reaches its yield stress first. In Fig. 8, the strain energy using the idealized bilinear curve until κ_u is the same as that using the actual moment–curvature curve.

The rotational capacity (i.e., μ_d) and the resistance factor for bending (i.e., ϕ) for the cross sections of interior and exterior beams, shown in Fig. 4, were evaluated. The characteristic yield strength of steel and the characteristic compressive strength of concrete varied between $F_{yk} = 235$ – 650 MPa and between $f_{ck} = 21$ and 30 MPa, respectively. Although not allowed in Eurocode 4 and JSCE 2009, high-strength steel of $F_{yk} = 650$ MPa was included in this investigation for a comparison between comparable design codes. For Eurocode 4 and JSCE 2009, the stress–strain relationships of concrete and steel presented in Table 2 were used for the fiber section analysis. For KSSC–KCI, the stress–strain relationships of concrete and steel proposed in the Sect. 3 were used. Reinforcements under compression in the concrete slab were ignored in the fiber section analysis.

Tables 6 and 7 show the values of M_k , M_d , ϕ_f , and μ_d for each design code, calculated from the fiber section analysis. Tables 6 and 7 are the results for the interior and exterior beams, respectively. For all design codes, as F_{yk} was increased from 235 to 650 MPa, M_k and M_d were increased, but μ_d was decreased. In particular, the value of μ_d of the exterior beam for $F_{yk} = 650$ MPa was 1.0, indicating brittle failure due to concrete crushing of the slab before the tensile yielding of the steel flange could occur. Thus, the rotational capacities of the composite beams were inversely proportional to F_{yk} . Additionally, when f_{ck} was increased from 21 to 30 MPa or b_{eff} was increased from 1000 to 2400 mm, M_k and M_d did not vary significantly but μ_d was increased. This indicates that to enhance the rotational capacity of composite beams under positive bending, the compression resistance of the concrete slab (e.g., concrete strength and effective flange width) need to be secured.

Figures 9 and 10 show the resistance factor for bending (ϕ)–curvature ductility (μ_d) relationships of interior and

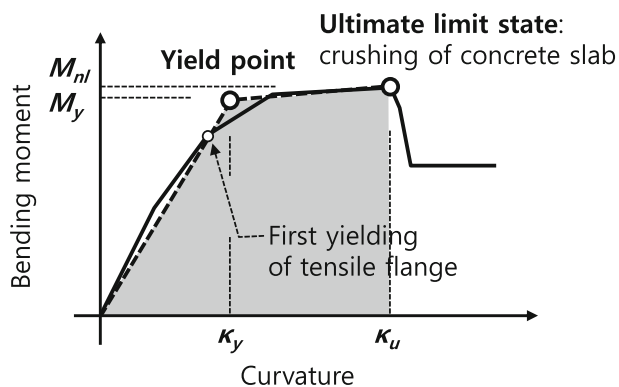

Fig. 8 Definition of ultimate limit state and yield point.

Table 6 Design results calculated from SCM: interior beams under positive bending.

f_{ck} (MPa)	F_{yk} (MPa)	KSSC-KCI				Eurocode 4				JSCE 2009			
		$M_k^{(1)}$	$M_d^{(1)}$	ϕ	μ_d	$M_k^{(1)}$	$M_d^{(1)}$	ϕ	μ_d	$M_k^{(1)}$	$M_d^{(1)}$	ϕ	μ_d
21	235	1282	1221	0.952	9.36	1282	1232	0.961	10.7	1461	1245	0.852	11.0
	315	1674	1534	0.916	5.73	1675	1544	0.921	6.17	1778	1504	0.845	6.70
	355	1841	1684	0.914	4.51	1847	1695	0.917	4.93	1916	1629	0.850	5.44
	450	2223	2008	0.903	2.99	2226	2023	0.908	3.30	2265	1920	0.847	3.58
	650	2914	2497	0.856	1.68	2915	2537	0.870	1.78	2874	2398	0.834	1.88
30	235	1310	1274	0.972	14.9	1311	1277	0.974	15.4	1575	1352	0.858	15.1
	315	1726	1655	0.958	8.30	1726	1667	0.965	8.76	1915	1652	0.862	8.80
	355	1928	1814	0.940	6.54	1928	1827	0.947	7.37	2085	1792	0.859	7.38
	450	2377	2189	0.920	4.51	2378	2204	0.926	4.81	2460	2107	0.856	4.82
	650	3194	2844	0.890	2.19	3200	2873	0.897	2.43	3195	2692	0.842	2.77

⁽¹⁾ M_k and M_d are the moment strengths for characteristic and design strengths of materials, respectively (Unit: kN m).

Table 7 Design results calculated from SCM: exterior beams under positive bending.

f_{ck} (MPa)	F_{yk} (MPa)	KSSC-KCI				Eurocode 4				JSCE 2009			
		$M_k^{(1)}$	$M_d^{(1)}$	ϕ	μ_d	$M_k^{(1)}$	$M_d^{(1)}$	ϕ	μ_d	$M_k^{(1)}$	$M_d^{(1)}$	ϕ	μ_d
21	235	1109	1020	0.919	4.37	1110	1024	0.922	4.38	1145	986	0.861	4.73
	315	1392	1271	0.913	2.79	1394	1281	0.918	2.96	1405	1208	0.859	3.08
	355	1519	1377	0.906	2.31	1524	1393	0.914	2.52	1524	1309	0.858	2.59
	450	1782	1581	0.887	1.67	1782	1604	0.900	1.76	1769	1506	0.851	1.86
	650	2078	1789	0.860	1.00 ⁽²⁾	2134	1821	0.853	1.00 ⁽²⁾	2099	1703	0.811	1.00 ⁽²⁾
30	235	1198	1092	0.911	5.51	1201	1098	0.914	5.86	1252	1065	0.850	6.18
	315	1506	1369	0.909	3.54	1506	1379	0.915	3.55	1525	1305	0.855	3.86
	355	1650	1493	0.904	2.93	1651	1507	0.912	2.93	1657	1419	0.856	3.15
	450	1960	1743	0.889	2.04	1964	1763	0.897	2.04	1938	1640	0.846	2.20
	650	2402	2032	0.846	1.00 ⁽²⁾	2434	2107	0.865	1.00 ⁽²⁾	2341	1953	0.834	1.00 ⁽²⁾

⁽¹⁾ M_k and M_d are the moment strengths for characteristic and design strengths of materials, respectively (Unit: kN m).

⁽²⁾ Crushing failure of the extreme fiber of concrete slab occurs before the tensile yielding of bottom flanges.

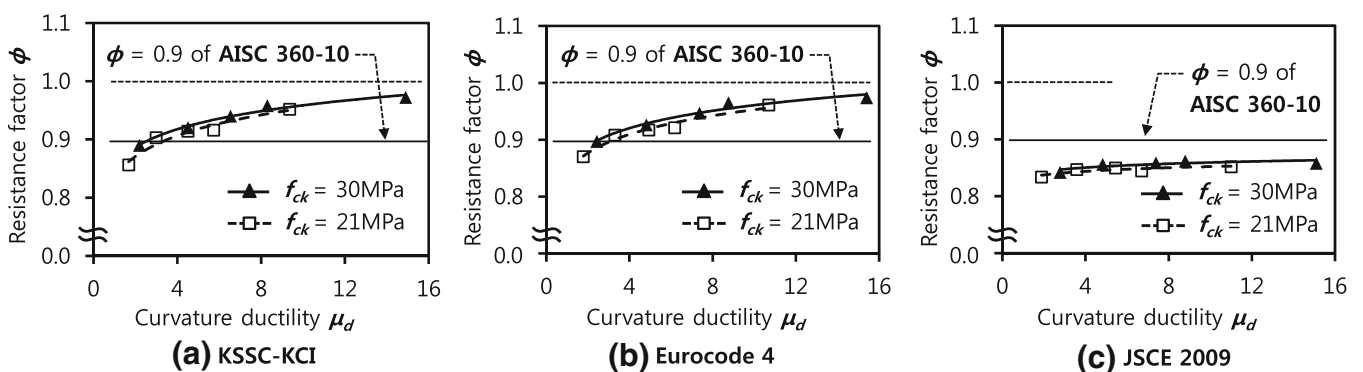

Fig. 9 Resistance factor for bending versus rotational capacity: interior beam.

exterior beams, respectively. In the figures, the values corresponding to $f_{ck} = 21$ and 30 MPa are marked as rectangles and triangles, respectively. For KSSC-KCI and Eurocode 4 that use PFM as their design format, $\phi (=M_d/M_k)$ was

increased, close to 1.0, as μ_d was increased. The trend in the ϕ - μ_d relationships of the interior and exterior beams was very similar (compare Figs. 9 and 10). The reason for this trend in the ϕ - μ_d relationships can be explained as follows.

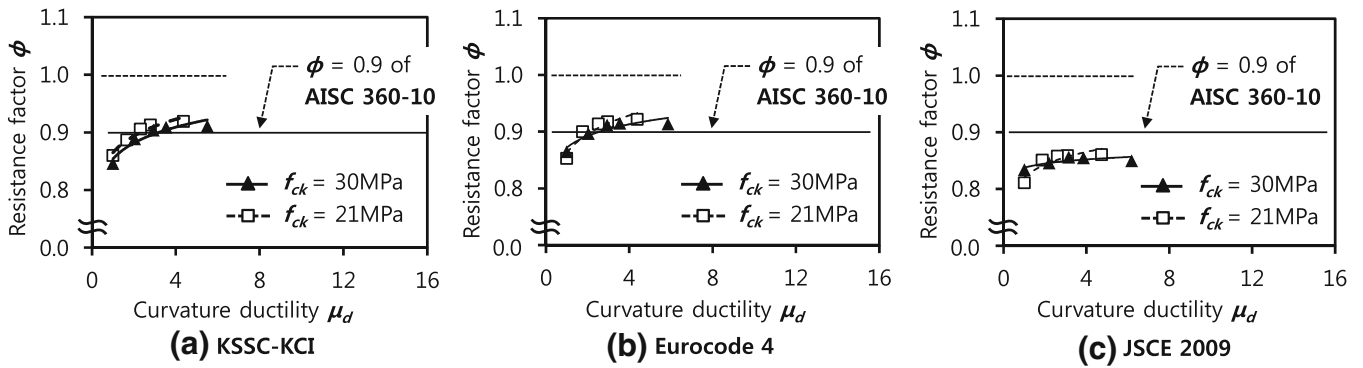

Fig. 10 Resistance factor for bending versus rotational capacity: exterior beam.

When the rotational capacity is small (e.g., $\mu_d \leq 3.0$), ϕ is primarily determined by the resistance and safety factors for concrete (i.e., $\phi_c = 0.65$ and $\gamma_c = 1.5$, respectively) because the moment strength of the cross section is dominated by the concrete flange, rather than by the steel section. On the other hand, when the rotational capacity is large (e.g., $\mu_d \geq 4.0$), ϕ is determined primarily by the resistance and safety factors for the steel (i.e., $\phi_s = 1.0$ and $\gamma_s = 1.0$, respectively) because the moment strength of the cross section is dominated by the steel section.

In contrast, for AISC 360-10 that uses LRFD as the design format, the resistance factor for bending ϕ is constant at 0.9, regardless of the rotational capacity (see the dashed lines in Figs. 9 and 10). Furthermore, ϕ of JSCE 2009 did not vary much according to μ_d because the member safety factor γ_b (=1.1) acted as a constant safety factor for bending (see Figs. 9c and 10c).

5.2 Comparison Between Design Strengths of PSDM and SCM

Figure 11 compares the design strengths of the interior beam under positive bending, calculated by the PSDM and SCM, $M_{d,PSDM}$ and $M_{d,SCM}$, respectively. The values of $M_{d,PSDM}$ and $M_{d,SCM}$ for each design codes are shown in Tables 3 and 6, respectively. The results for the exterior beam under positive bending are presented in Tables 4 and 7 and Fig. 12. For KSSC-KCI and Eurocode 4, the ratios of $M_{d,SCM}/M_{d,PSDM}$ were mostly greater than 1.0, and increased as the yield strength of steel was increased from $F_{yk} = 235$ to 650 MPa. This indicates that by using the SCM, an

economical structural design for composite beams may be possible, especially if high-strength steel is used.

$M_{d,SCM}$ greater than $M_{d,PSDM}$ shown in Figs. 11 and 12 were attributed to two reasons. First, the reduction factor β specified in KSSC-KCI and Eurocode 4 did decrease the design strengths of cross sections calculated from the PSDM. Additionally, because β decreases as D_p/D_t increases, $M_{d,PSDM}$ decreased further especially when high-strength steels of $F_{yk} = 450$ and 650 MPa were used. Second, the compressive stress distribution of concrete flange did increase the design strengths calculated by the SCM. Figure 13 illustrates the stress and strain distributions of the interior beam for KSSC-KCI ($f_{ck} = 21$ MPa and $F_{yk} = 235$ MPa), calculated from the fiber section analysis. The neutral axis at the ultimate limit state was located in between the concrete slab and the compression flange of steel section (i.e., 124 mm deep from the top surface of the concrete slab). The calculated maximum and minimum compressive stresses in the concrete flange were $1.0f_{cd}$ and $0.608f_{cd}$, respectively, and the mean value was $0.93f_{cd}$. Clearly, the mean stress $0.93f_{cd}$ was 13 % greater than the plastic stress of concrete assumed for the PSDM, $0.85f_{cd}$. This, along with the reduction factor β (=0.957; see Table 3), resulted in the 7.0 % greater $M_{d,SCM}$ (=1221 kN m) than $M_{d,PSDM}$ (=1141 kN-m).

Figures 11c and 12c show the ratios of $M_{d,SCM}/M_{d,PSDM}$ of the interior and exterior beams, respectively, calculated from JSCE 2009. The ratios of $M_{d,SCM}/M_{d,PSDM}$ were mostly greater than 1.0 but, in contrast to KSSC-KCI and Eurocode 4, decreased as the yield strength of steel was increased from $F_{yk} = 235$ to 650 MPa. This difference between $M_{d,SCM}$ and

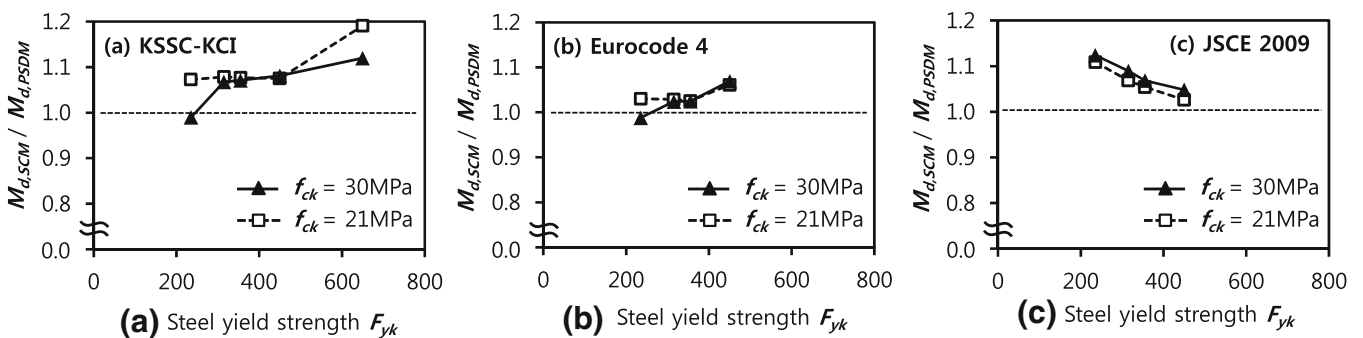

Fig. 11 Comparison of design strengths calculated from PSDM and SCM: interior beam.

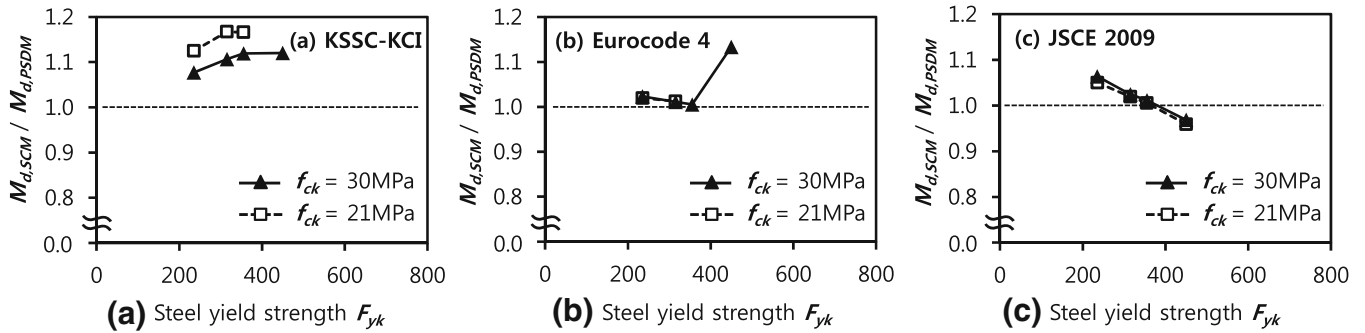

Fig. 12 Comparison of design strengths calculated from PSDM and SCM: exterior beam.

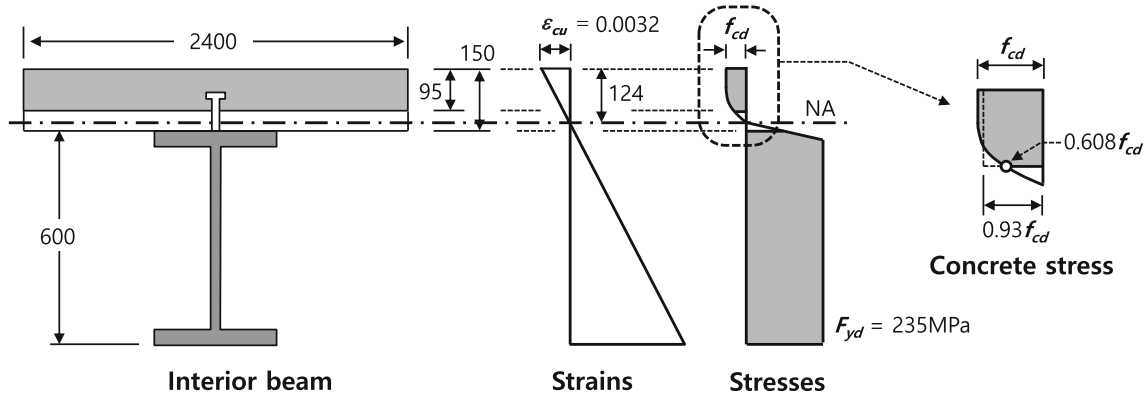

Fig. 13 Strain and stress distributions at ultimate limit state: interior beam for KSSC–KCI 2014 ($f_{ck} = 21$ MPa and $F_{yk} = 235$ MPa).

$M_{d,PSDM}$ was attributed to the strain-hardening behavior of steel addressed in the SCM (see Table 2), as follows. Because JSCE 2009 allows a tensile stress of steel greater than the yield strength due to the strain-hardening behavior, basically, $M_{d,SCM}$ can be greater than $M_{d,PSDM}$. However, when high-strength steel is used, the stress increase of steel is less significant because the rotational capacity of cross sections is poor. Thus, the difference between $M_{d,SCM}$ and $M_{d,PSDM}$ is greatly reduced, especially if high-strength steels of $F_{yk} = 450$ and 650 MPa are used.

6. Summary and Conclusion

In this study, provisions for the flexural design of composite beams specified in KSSC–KCI (i.e., a draft version prepared by the KSSC–KCI joint composite structure committee), Eurocode 4, and JSCE 2009, which use PFM as their design format, were compared with those of AISC 360-10 and KBC 2014 based on LRFD, in terms of design format, material strength, and resistance or safety factor. Additionally, the design moment strengths M_d of the cross sections, calculated by the plastic stress design method (PSDM) and strain-compatibility method (SCM) specified in each design code, were investigated quantitatively. The major findings of this study can be summarized as follows.

1. The design strength M_d and resistance factor for bending ϕ , calculated from the PSDM specified in KSSC–KCI, Eurocode 4, and JSCE 2009, varied significantly with

material and section properties. For positive bending, M_d and ϕ of KSSC–KCI and Eurocode 4 showed decreasing trends as the depth of the plastic neutral axis increased. In particular, the reduction factor β reduced the design values further for high-strength steel. M_d and ϕ of Eurocode 4 were mostly greater than the design values of AISC 360-10. However, the design values of KSSC–KCI and JSCE 2009 were less than those of AISC 360-10. For negative bending, the design strengths of KSSC–KCI and Eurocode 4 that define the safety or resistance factor for steel as 1.0 were about 10 % greater than those of AISC 360-10 that use the resistance factor for bending as $\phi = 0.9$.

2. The resistance factor for bending ϕ calculated from the SCM specified in KSSC–KCI and Eurocode 4 was increased, close to 1.0 from 0.85, as the rotational capacity of the cross section was increased. This is because, in the case of the PFM that uses different resistance factors for concrete and steel, the overall resistance factor for bending of the cross sections was determined primarily by concrete or steel, whichever was dominant. For JSCE 2009, on the other hand, ϕ did not vary much according to the rotational capacity because the member safety factor $\gamma_b (=1.1)$ acted as a constant safety factor for bending.
3. For KSSC–KCI and Eurocode 4, the design strengths M_d of the cross section under positive bending calculated from the SCM were greater than those by PSDM. The SCM was beneficial to prevent brittle failure of

composite beams due to early concrete crushing and to achieve economical designs, especially when high-strength steel of $F_{yk} = 420\text{--}650$ MPa is used. For JSCE 2009, the SCM was most economical for composite beams using normal-strength steel.

Acknowledgments

The present research was conducted by the research fund of Dankook university in 2014.

Open Access

This article is distributed under the terms of the Creative Commons Attribution 4.0 International License (<http://creativecommons.org/licenses/by/4.0/>), which permits unrestricted use, distribution, and reproduction in any medium, provided you give appropriate credit to the original author(s) and the source, provide a link to the Creative Commons license, and indicate if changes were made.

References

- American Association of State Highway and Transportation Officials. (2012). *AASHTO LRFD specifications* (6th ed.). Washington DC.
- American Institute of Steel Construction. (2010). Specifications for structural steel buildings, AISC 360-10, Chicago, IL.
- Architectural Institute of Korea. (2014). Korea Building Codes (Draft), KBC 2014, Seoul (in Korean).
- European Committee for Standardization. (2004a). Eurocode 4: Design of composite steel and concrete structures, Part 1-1: General rules and rules for buildings, EN 1994-1-1:2004.
- European Committee for Standardization. (2004b). Eurocode 2: Design of concrete structures—Part 1-1: General rules and rules for buildings, EN 1992-1-1:2004.
- Japan Society of Civil Engineers. (2007). Standard specifications for concrete structures—2007—“Design”, JSCE Guidelines for Concrete No. 15
- Japan Society of Civil Engineers. (2009). Standard specifications for steel and composite structures.
- Kim, D. H., Kim, J. H., & Chang, S. K. (2014). Material performance evaluation and super-tall building applicability of the 800 MPa high-strength steel plates for building structures. *International Journal of Steel Structures*, 14(4), 889–900.
- Kim, T. S., Lee, M. J., Suk, O. Y., Lee, K. M., & Kim, D. H. (2012a). A study on compressive strength of built-up H-shaped columns fabricated with HSA800 high performance steels. *Journal of the Korean Society of Steel Construction, KSSC*, 24(6), 627–636. (in Korean).
- Kim, C. S., Park, H. G., Chung, K. S., & Choi, I. R. (2012b). Eccentric axial load testing for concrete-encased steel columns using 800 MPa steel and 100 MPa concrete. *Journal of Structural Engineering*, 138(8), 1019–1031.
- KSSC–KCI Joint Composite Structure Committee. (2014). *Design codes of composite structures (Draft)*. Seoul, Korea: Korean Society of Steel Construction. (in Korean).
- Lee, C. H., Han, K. H., Kim, D. K., Park, C. H., Kim, J. H., Lee, S. E., & Ha, T. H. (2012). Local buckling and inelastic behavior of 800 MPa high-strength steel beams. *Journal of Korean Society of Steel Construction, KSSC*, 24(4), 479–490. (in Korean).
- Lee, C. H., Han, K. H., Uang, C. H., Kim, D. K., Park, C. H., & Kim, J. H. (2013a). Flexural strength and rotation capacity of I-shaped beams fabricated from 800-MPa. *Journal of Structural Engineering, ASCE*, 139(6), 1043–1058.
- Lee, C. H., Kang, K. Y., Kim, S. Y., & Koo, C. H. (2013b). Review of structural design provisions of rectangular concrete filled tubular columns. *Journal of the Korean Society of Steel Construction, KSSC*, 25(4), 389–398. (in Korean).
- Lee, C. H., Kim, D. K., Han, K. H., Park, C. H., Kim, J. H., Lee, S. E., & Kim, D. H. (2013c). Tensile testing of groove welded joints joining thick-HSA800 plates. *Journal of the Korean Society of Steel Construction, KSSC*, 25(4), 431–440. (in Korean).
- Lee, M. J., Kim, C. W., & Kim, H. D. (2014). The evaluation of the axial strength of composite column with HSA800 grade steel. *Journal of the Korean Society of Steel Construction, KSSC*, 24(6), 627–636. (in Korean).
- Wittry, D.M. (1993). An analysis study of the ductility of steel-concrete composite sections, MS Thesis, University of Texas, Austin, TX.
- Youn, S. G. (2013a). Nominal moment capacity of hybrid composite sections using HSB600 high-performance steel. *International Journal of Steel Structures, KSSC*, 13(2), 243–252.
- Youn, S. K. (2013b). Reevaluation of nominal flexural strength of composite girders in positive bending region. *Journal of the Korean Society of Steel Construction*, 25(2), 165–178. (in Korean).