

ASM

PSM

PMaSynRM

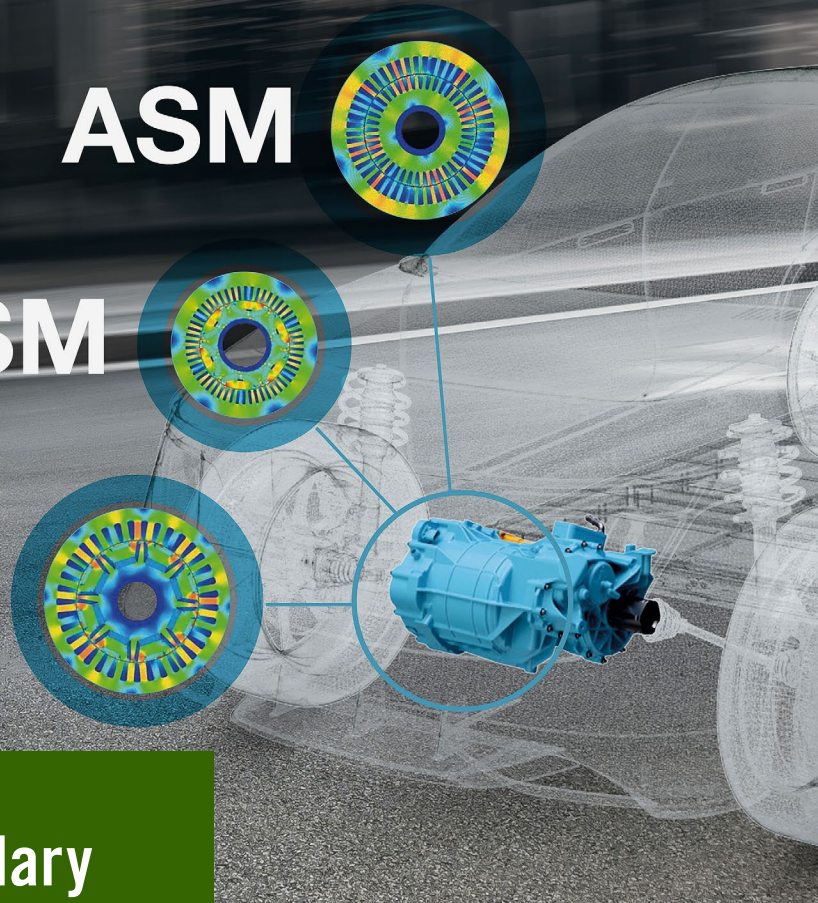

E-motor Types for Secondary Electric Drives in Comparison

Following the success of electric cars, choosing the best suitable e-machines is increasingly coming into focus. This article from Magna Powertrain compares the characteristics of induction machine, permanent magnet synchronous machine, and permanent magnet hybrid synchronous machine with reluctance torque for their use as secondary drives. A detailed comparison of key performance indicators and vehicle application is crucial for making the right choice.

AUTHORS



Dipl.-Ing. (FH) Werner Ness is Senior Manager, Global Product Management, eMachine and Inverters at the Magna Powertrain GmbH & Co KG in Traiskirchen (Austria).



Dr. Klaus Raggl is Senior Manager, Advanced Engineering eMachine and Inverters at the Magna Powertrain GmbH & Co KG in Traiskirchen (Austria).

In current and future generations of electrically powered vehicles, electric secondary drives are also gaining in importance. This is not only due to the all-wheel drive capability and driving dynamics advantages gained, but also to the need to scale the power output. In their simplest form e-drive systems include a unit comprising the e-machine, inverter with software, and the transmission. As secondary drives, they are used in addition to the main e-drive, but only temporarily. Therefore, the characteristics of various e-machine designs must be rated differently than for primary drives.

In this paper, three e-machine designs are examined: the Induction Machine (IM, also known as Asynchronous Machine, ASM), the Permanent magnet hybrid Synchronous Machine with reluctance torque (PSM), and the Permanent Magnet assisted Synchronous Reluctance Machine (PMaSynRM), **FIGURE 1**. After all, a PSM in conjunction with a Decoupling Unit (DCU) is considered, as the DCU allows for eliminating the drag losses. Another interesting machine

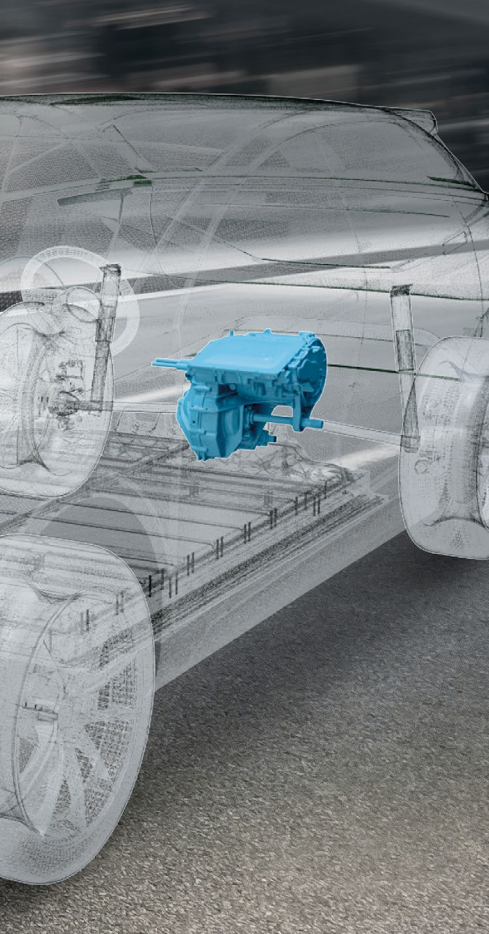

© Magna

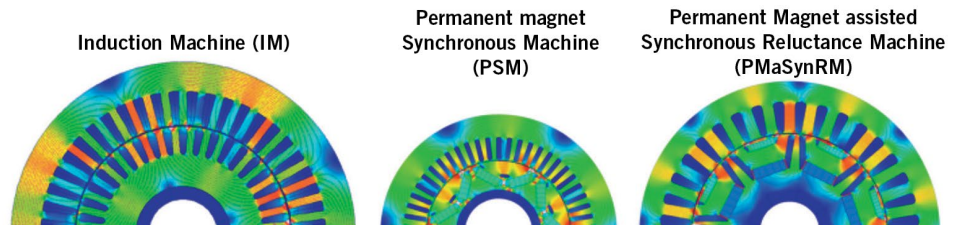

FIGURE 1 Electromagnetic design of IM, PSM and PMSynRM (© Magna)

type would be the Separately excited Synchronous Machine (SSM) with an radio frequency transformer. However, this was not included in this comparison due to the costs and complexity within the overall system.

METHODICAL BACKGROUND

Secondary drives are only used in certain driving situations. These typically include snow or dynamic driving with increased longitudinal and lateral dynamic requirements. Thus, while traction and driving dynamics are important criteria, efficiency plays practically no role in the Worldwide harmonized Light Duty Test Cycle (WLTC), because the secondary drive is not needed in this cycle. The comparison assumes C- to E-segment vehicle applications, including SUVs, which require a secondary drive of about 90 to 150 kW_p (peak power). The standard Key Performance Indicators (KPI) included are cost, peak power, continuous power, efficiency, raw materials, drag losses, response times,

package, and mass. Following cost, peak power is the most important criterion. The peak power is not only important for vehicle dynamic requirements, but also for the regeneration capability. The focus is less on continuous power on the other hand, as this is provided by the primary drive. The peak power is required to be available stably for up to 30 s.

The efficiency of the e-machines will only be briefly considered, as the secondary drive is generally used for less than 10 % of the driving time. For overall efficiency, it is more important to consider which design causes the lowest drag losses when being passive. In line with common requirements of the automobile manufacturers, a typical average axle speed of around 600 rpm is assumed. Another criterion, the torque response time, was described in [1]. Even more important than low mass is the package. There is an interest in keeping the package as small as possible to gain interior space and storage capacity. Finally, other important criteria are cost and availability of raw materials. For example, from experience the cost fluctuations for neodymium, dysprosium or terbium can be over 300 %. As an alternative, although less efficient, ferrite magnets can be considered. There are also price fluctuations for copper, which must be included in the risk assessment. After all, fulfilling environmental and social requirements when extracting raw materials, are an essential factor to ensure the sustainability of the e-drives.

ESSENTIAL E-MACHINE CHARACTERISTICS

Regarding characteristics such as efficiency, power, and drag losses, the three machine types differ significantly [2, 3]. The IM is long-time-proven as a robust machine variant that does not require

permanent magnets. However, it is larger, heavier, and needs significantly more copper. In terms of continuous power, the IM performs unfavorably in this comparison, because its output is less than 25 % of its peak power. However, as mentioned, this criterion is negligible for a secondary drive. The IM performs well at peak power up to a duration of 30 s, **FIGURE 2**. Yet, due to the rotor losses, the IM is less efficient compared with the PSM. However, it has the advantage that only very low drag losses occur in the inactive state. In terms of package and mass, the IM is disadvantageous due to its comparatively low power density.

Today, the PSM has become the preferred choice for most applications that require high power density, and thus low mass and small package size. It also requires less expensive cooling, because the rotor induces less heat. Among the three e-machine types, the PSM has the highest efficiency but high drag losses occur in the passive state. While copper is a comparatively small cost factor for the PSM, the volatile prices for rare-earth metals entail a higher cost risk.

The PSM with the optional mechanical DCU was described in more detail in [1]. The e-machine itself is identical, but thanks to the DCU, no drag losses occur. However, this system requires a fast-reacting control system to make the power available in less than 200 to 250 ms when needed. To achieve quick reaction times, the machine is kept on standby at a synchronous speed at approximately 130 km/h. The losses associated with this are included in the cycle efficiency analysis. The system is package-neutral, as the DCU within the Magna solution hides side-by-side of the e-machine.

Another third e-machine variant is the PMSynRM. This is essentially a PSM being characterized by a large

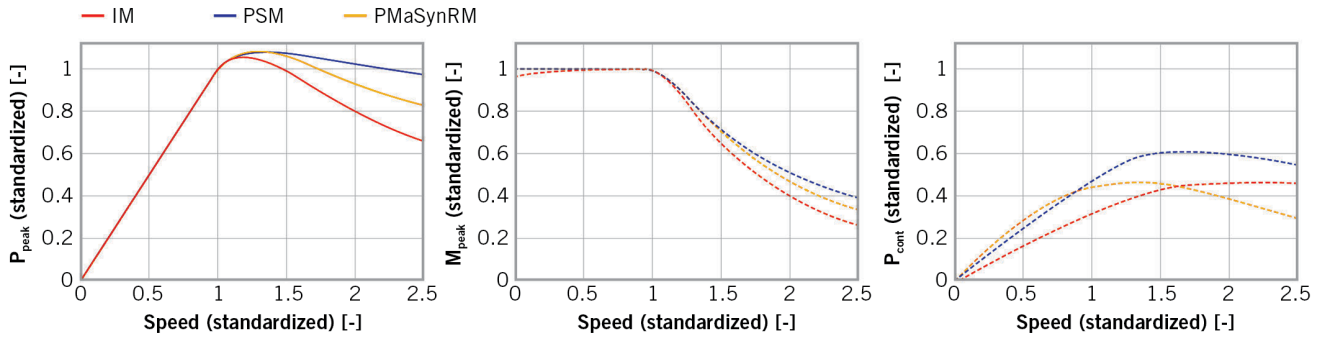

FIGURE 2 Performance comparison of IM, PSM and PMaSynRM, standardized to the reference point (© Magna)

difference between transverse and longitudinal reluctance in the rotor. At first, a low-cost variant with ferrite magnets was examined. It turned out that the required performance, especially at high speeds, could not be achieved. A mixed design including only a proportion of rare-earth magnets proved to be a good compromise. This mixed concept is characterized mainly by two factors: On the one hand, the costs for copper are lower than for the IM and on the other hand, the costs for the magnets are lower than for the PSM. The drag losses of the PMaSynRM of this type are on the same level as those of the IM.

The machine was designed in such a way that the back electromotive force is always lower than the minimum direct current link voltage. This results in another advantage in terms of functional safety and costs for the inverter:

While the PSM must be designed to be short-circuit-proof (Active Short Circuit, ASC), both IM and PMaSynRM in the present design can manage with a so-called open circuit layout (all switches open).

COMPARISON AND EVALUATION

The results of the following comparison apply to a vehicle application including a secondary axle with 100 kW peak power. As mentioned, continuous power (P_{cont}) plays a minor role in the secondary drive. One exception is the power needed at very high speeds when full power is required on both axles. The ratio of the continuous power at maximum speed (n_{max}) to the possible peak power (P_{cont}/P_{peak}) with common water jacket or oil cooling is $\leq 25\%$ for the IM and $\geq 50\%$ for the PSM. The PMaSynRM is in between with $\leq 35\%$.

Regarding the peak power (P_{peak}), it is noticeable that the PSM has the smallest power drop at high speed. The present PMaSynRM design behaves similarly. It has its efficiency maximum in the medium speed range at higher torques. The P_{peak} of the IM, on the other hand, drops more sharply over speed. The comparison of the three e-machine types is illustrated in FIGURE 2 and FIGURE 3. The result is different when the power density is considered, which affects package, mass and material costs. For the IM, the value is $< 30 \text{ kW}_p/\text{dm}^3$, while for the PSM it is over $45 \text{ kW}_p/\text{dm}^3$. The PMaSynRM follows closely with about $40 \text{ kW}_p/\text{dm}^3$ regarding the volume of the active parts.

The major influence on the overall efficiency results from the drag losses. A PSM as a secondary drive without the possibility to decouple the e-machine is not a feasible option. The

FIGURE 3 Efficiency maps of IM (left), PSM (center) und PMaSynRM (right) (© Magna)

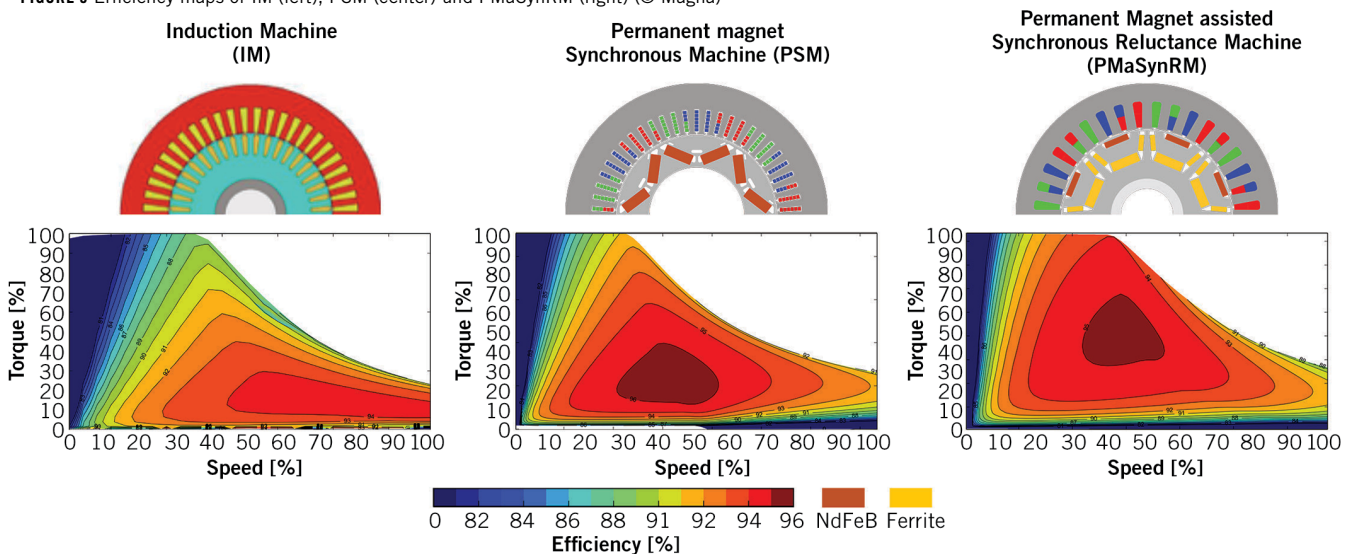

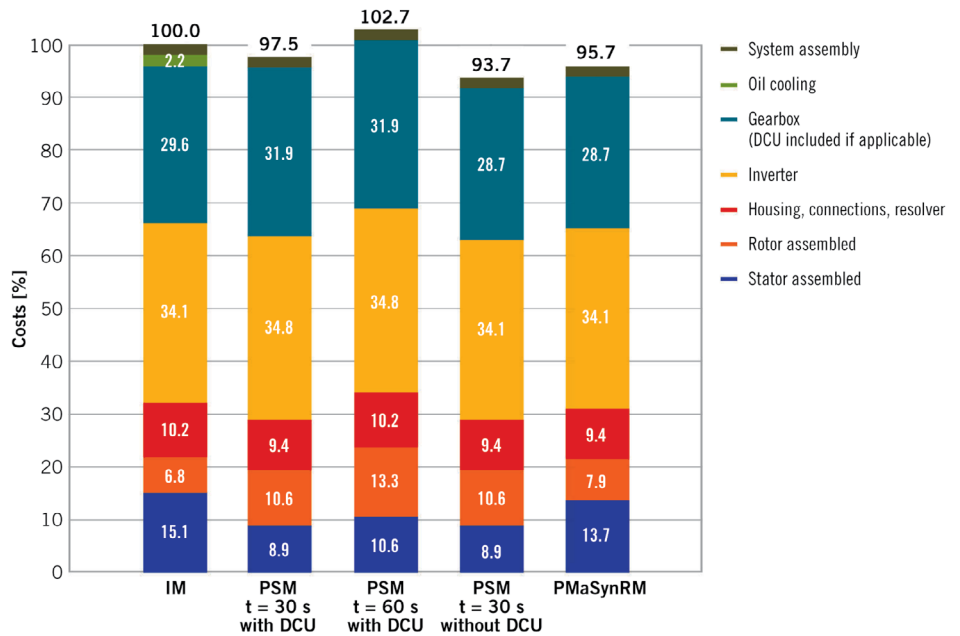

FIGURE 4 Cost comparison of e-machine types including the PSM design with a DCU (t = duration for which P_{peak} is available) (© Magna)

losses would be unacceptable at around 600 W at 600 rpm. By decoupling, on the other hand, the drag losses of the e-machine and the gearbox can be reduced to zero. In the case of the IM, the power loss is about 150 W [1], mainly caused by bearing losses, air gap losses and, if applicable, churning losses through the oil cooling. With the PMaSynRM hybrid design considered, the losses without decoupling are < 270 W. The response time for the torque buildup of a PSM and PMaSynRM is less than 10 ms, and

50 to 70 ms for the IM, depending on the pilot control.

COST CONSIDERATION

The cost comparison for the three machine types is shown normalized and simplified in **FIGURE 4**. The major relative differences can be seen for the rotor, caused by the rare-earth magnets. For the stator of the IM on the other hand, copper is the major cost factor. In the case of the PMaSynRM, the proportion of ferrite magnets reduces the

costs; specifically, it is about two-thirds of the total mass. Least expensive would be the PSM without DCU theoretically, but with the disadvantages described. In all other areas, absolute differences are smaller.

The data basis for the comparison is based on average market prices for copper, electrical steel, neodymium, and dysprosium in 2020. The highest cost risk is associated with the market prices for rare-earth materials and, to a lesser extent, copper. Of course, it is difficult to predict, how material costs will develop

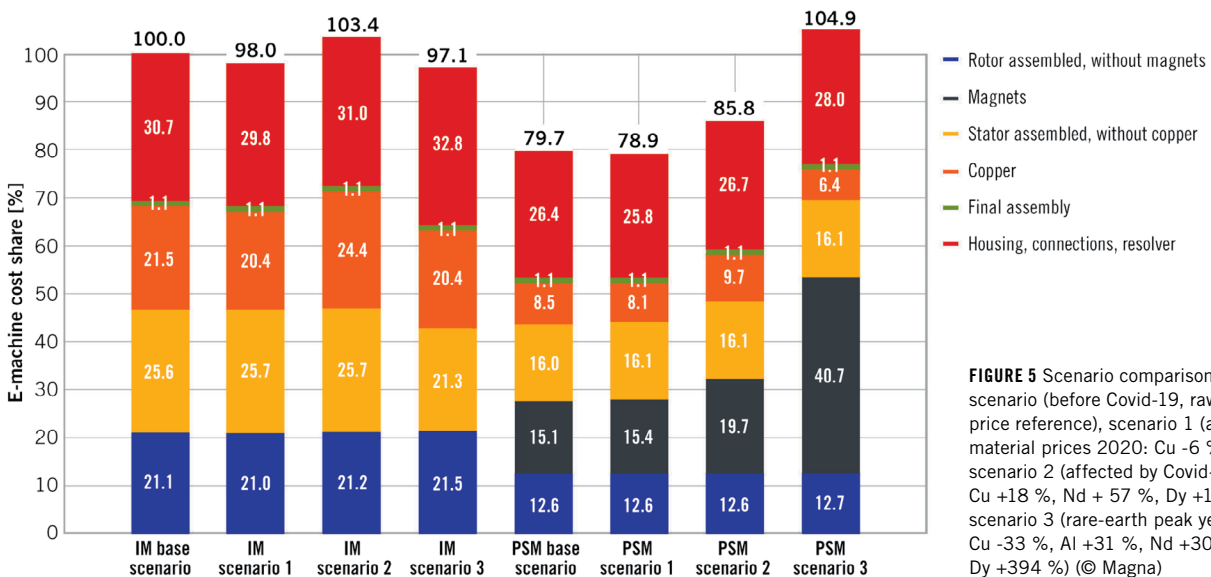

FIGURE 5 Scenario comparison: base scenario (before Covid-19, raw material price reference), scenario 1 (average raw material prices 2020: Cu -6 %, Dy +10 %), scenario 2 (affected by Covid-19: Cu +18 %, Nd + 57 %, Dy +10 %), scenario 3 (rare-earth peak year 2011: Cu -33 %, Al +31 %, Nd +300 %, Dy +394 %) (© Magna)

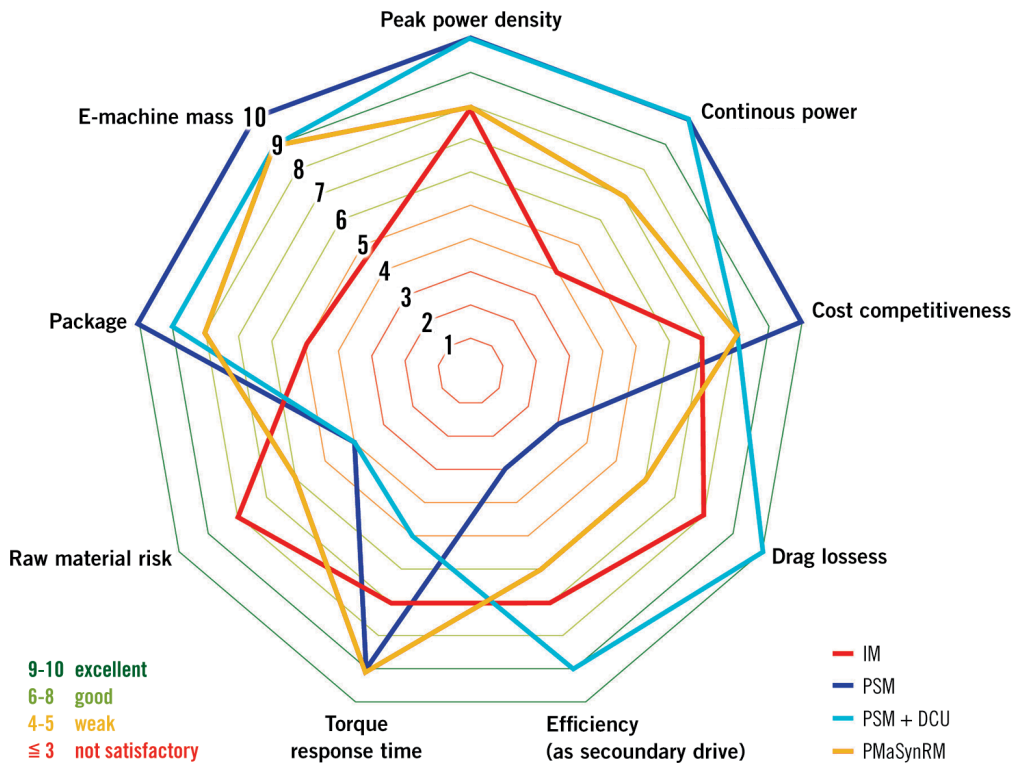

FIGURE 6 Qualitative comparison of IM, PSM und PMaSynRM characteristics, including the PSM design with a DCU (© Magna)

in the future. In the peak year 2011, for example, prices for neodymium and dysprosium briefly increased by a factor of twenty to thirty. Political developments or decisions on environmental and social compliance may also have an impact here. Magna simulated four scenarios to approximate the impact: market prices in February 2020 (before Covid-19), average prices in 2020, prices in December 2020 (influenced by Covid-19), and those in the peak year 2011 [4]. Only in the last scenario the IM was more cost-effective in the overall system comparison, FIGURE 5.

SUMMARY AND OUTLOOK

FIGURE 6 summarizes the strengths and weaknesses of the three e-machine types considered in qualitative terms. One of the most interesting findings of the study is that it is not the need for expensive rare-earth magnets that argues against

a PSM or a PMaSynRM, as is often assumed. Due to the different machine characteristics of the compared drives, for example, the required continuous power, reaction times, or installation space requirements may have a stronger impact on the overall costs, performance, and other benefits.

Individually, an evaluation is always required for the specific application, taking into account the desired operating strategy and installation space targets. Magna Powertrain has the experience and simulation toolchains to holistically optimize e-machine type and characteristics, vehicle framework conditions as well as application-specific requirements as an overall system. In an individual case, each of the e-machine types compared may prove to be appropriate.

Evaluating the KPIs is an ongoing process. For example, the raw materials market must continue to be moni-

tored, as must new technical approaches that can be used to reduce the proportion of rare-earths. New findings are regularly incorporated into Magna Powertrain’s development tools, to be able to offer the optimum synthesis of costs and product properties for specific applications.

REFERENCES

[1] Lindvai-Soos, D.; Kaimer, S.: Electric Drives for All-wheel Functions – A System Comparison of ASM and PSM. In: ATZworldwide 1/2022, pp. 48-51
 [2] Neudorfer, H.: Weiterentwicklung von elektrischen Antriebssystemen für Elektro- und Hybridstraßenfahrzeuge. Wien: Österreichischer Verband für Elektrotechnik, 2010
 [3] Bolte, E.: Elektrische Maschinen. Hamburg/Berlin: SpringerVieweg, 2018
 [4] Elsner, H.: Kritische Versorgungslage mit schweren Seltenen Erden – Entwicklung „Grüner Technologien“ gefährdet? Online: https://www.bgr.bund.de/DE/Gemeinsames/Produkte/Downloads/Commodity_Top_News/Rohstoffwirtschaft/36_kritische-versorgungslage.pdf?__blob=publicationFile&v=4, access: November 16, 2021



chassis.tech plus 2022

4 congresses in one Event

5 – 6 July 2022
Munich, Germany
or virtually via live stream

- / **chassis.tech**
Innovative chassis systems
- / **steering.tech**
Smart steering
- / **brake.tech**
Modern braking systems
- / **tire.wheel.tech**
Reliable tire-wheel components

**HYBRID
CONGRESS**

—
Additionally with
live streams
and video chats

chassis.tech
plus

chassis.tech
steering.tech
brake.tech
tire.wheel.tech

