



# Testing the validity of the brief beneficence satisfaction scale in Turkish context

Samet Şahin<sup>1</sup> · Aslı Uz Baş<sup>1</sup>

Accepted: 6 October 2021 / Published online: 12 October 2021

© The Author(s), under exclusive licence to Springer Science+Business Media, LLC, part of Springer Nature 2021

## Abstract

The aim of the present study was to adapt the Brief Beneficence Satisfaction Scale (BBSS) (Martela & Ryan, 2015) into Turkish context and to test its psychometric properties. The study included a community sample of 322 (61% women, 30% men and 9% unspecified). Confirmatory factor analysis verified a four-item single factor model. The BBSS-TR showed positive correlations with altruism and subjective happiness, indicating similar correlation coefficients as in the original study. The Cronbach's alpha reliability coefficient for the BBSS-TR was .85. Results concluded that the BBSS-TR is a valid and reliable measure to be used in future research. The importance of beneficence satisfaction as a new psychological concept has been discussed.

**Keywords** Beneficence · Scale · Adaptation · Turkish · Positive psychology

## Introduction

To do good is a virtue that has been emphasized throughout human history and it can even be described as a supra-cultural phenomenon, that is, to varying degrees, doing good for one's environment is something that is at least universally approved, if not practiced. One's striving for the good of others has so far been investigated frequently under the concept of 'altruism.' Altruism, as a pro-social practice that can be best described as 'to love one's neighbor as oneself', shows itself in many ways, such as general concern for the welfare of others (Dovidio et al., 2006), informal helping ranging from advice and social support to daily chores (Riche & Mackay, 2010), volunteering (Bekkers, 2006; Piliavin & Siegl, 2007) and spending money on others (Camerer, 2003) without expecting any reward or repayment.

Although altruistic acts are not done for external rewards or repayment, it has been argued that their frequency in human behavior may result from their contribution to one's wellness (Martela, & Ryan, 2015). Remarkably, psychological research showed that those who do good, in fact do well. Cross-cultural research have so far been able to show

the link between altruism and well-being in many different countries such as the USA (Schwartz et al., 2009; Thoits & Hewitt, 2001), Turkey (Gülaçtı, 2014; İsgör, 2017), Mexico (Corral-Verdugo et al., 2013), China (Feng & Guo, 2016), India (Sharma & Singh, 2019) and Uganda (Aknin et al., 2013a). Moreover, these studies also differ in terms of their samples' developmental characteristics, which even more clearly points out the importance of altruism with regards to well-being. In fact, researchers have used the term 'psychological universal' as they explain the beneficial nature of pro-social activity (Aknin et al., 2013a).

The observations mentioned above led researchers across the world to investigate *why* and *how* altruism leads to well-being, and, as a result, various scales have been adapted or developed with the aim of studying altruism and its correlates. However, a quick literature review either in English or in one's language will easily show that the present assessment tools seem to be unable to go further than answering who is more altruistic or whether those who engage in pro-social behavior are happier. As it has been argued before (see Martela & Ryan, 2015), many of the existing scales try to quantify altruistic behavior without assessing one's satisfaction of them.

To elaborate on the quantification problem, it seems helpful to take as an example the Self-Report Altruism Scale (Rushton et al., 1981), one of the frequently used altruism scales, which to this day keeps being adapted to different

✉ Samet Şahin  
sametsahin\_@hotmail.com

<sup>1</sup> Counseling and Guidance, Dokuz Eylül University, İzmir, Turkey

languages (for its Turkish adaptation, see Tekeş & Hasta, 2015). Rating items such as ‘I have made change for a stranger’ or ‘I have donated blood’ based on frequency may be problematic, in that, 1) people might differ in their personal types of altruistic behaviors and 2) people might differ in how much they psychologically benefit from a certain altruistic behavior. Moreover, items such as ‘I have given a stranger a lift in my car’ might be rated less frequent in cultures where there is perceived risk in close contact with strangers. Therefore, forced behavioral choices and frequency ratings can provide misleading results both within and across cultures. It can be argued that psychologically sound altruism scales that focus on one’s overall subjective satisfaction would yield more accurate results, if one’s main goal is to investigate how it relates to other variables.

On the other hand, researchers like Martela and Ryan (2015) seem to share similar concerns in having developed the Brief Beneficence Satisfaction Scale. The Brief Beneficence Satisfaction Scale is a 4-item and one-factor altruism scale that focuses on one’s overall satisfaction with their pro-social activity (namely, beneficence satisfaction). Building upon some prior research to measure perceived pro-social impact (e.g., Aknin et al., 2013b; Grant, 2008), Martela and Ryan (2015) have attempted to develop a brief and psychometrically sound scale of beneficence satisfaction. Rather than listing or quantifying behaviors, the Brief Beneficence Satisfaction Scale asks participants about their subjective feeling of pro-social impact. By doing so, the scale is believed to have provided applicability across different behaviors and contexts.

The aim of the present study is to adapt the Brief Beneficence Satisfaction Scale into Turkish and examine the psychometrical properties of the Turkish form. To this end, the relationships between beneficence satisfaction (Martela & Ryan, 2015), altruism (Rushton et al., 1981) and subjective happiness (Lyubomirsky & Lepper, 1999) are examined along with other psychometrical examinations. It is hoped that the adapted scale will be used in positive psychology studies in Turkey, a country in which positive psychology has recently become an emerging field of study.

## Method

### Participants

Online data collection method was used to obtain research data during the COVID-19 pandemic. Online versions of the research scales were prepared and sent to postgraduate students via WhatsApp groups. Snowball sampling technique was chosen to reach participants.

A total of 372 participants answered the survey but participants were given an instruction in between the items of

SRA-TR, the present research’s longest scale (Please, choose ‘3’ before you go on to the next item) to detect random responding. From 1 to 5, those who chose a different number than ‘3’ were deleted. As a result, five participants were omitted. Moreover, since online responding may result in duplicate cases, the data were accordingly analyzed in SPSS and 39 duplicate cases were found. After their omission, 328 participants remained. Finally, in assessing multivariate normality, six outliers were found to cause violation. After their elimination, the final sample was 322 (86.6%). Participants’ mean age was 27 (range = 18–65) and 61% were women (30% men and 9% unspecified). Table 1 shows the participants’ demographics in detail.

### Instruments

**The Brief Beneficence Satisfaction Scale (BBSS)** BBSS was a one-factor scale that included four items in total. It has been developed by Martela and Ryan (2015) over a sample of 335 participants aged between 18–74 (64% women and mean age = 37). The scale is a 7-point Likert type scale ranging from 1 (*not at all true*) to 7 (*very true*). The reliability of this scale was 0.81 in the original study.

**Table 1** Participant demographics

	<i>N</i>	%
Gender		
Female	196	61%
Male	98	30%
Unspecified	28	9%
Marital status		
Single	246	76%
Married	71	22%
Divorced	5	2%
Employment status		
Student	95	30%
Employee	93	29%
Unemployed	67	21%
Employed student	35	11%
Unspecified	32	10%
Socioeconomic status		
Medium	229	71%
Low	55	17%
Unspecified	28	9%
High	10	3%
Educational status		
Higher education	264	82%
Secondary school	47	15%
Primary school	11	3%
Total	322	

**The Turkish Self-Report Altruism Scale (SRA-TR)** Originally developed by Rushton et al. (1981), the Turkish version of the scale has been adapted by Tekeş and Hasta (2015). The scale was adapted into Turkish over an online sample of 282 participants aged between 18–54 (67% men and mean age = 27). SRA-TR included a total of 20 items in two sub-scales (*helping* and *philanthropy*). The reliability coefficients for the two Turkish sub-scales were 0.81 and 0.70 respectively. The reliability of the entire scale was 0.84. SRA-TR requires participants to rate the frequency of certain pro-social behaviors that they had shown on a scale ranging from 1 (*never*) to 5 (*always*).

**The Turkish Subjective Happiness Scale (SHS-TR)** Originally developed by Lyubomirsky and Lepper (1999), The Turkish version of the scale has been adapted into Turkish by Doğan and Totan (2013) over two different samples. The first sample consisted of 348 university students (66% women and mean age = 22) and the second of a community sample of 222 participants aged between 18–61 (63% women and mean age = 39). SHS-TR is a 7-point Likert type scale that has a total of 4 items in a single factor. The reliability coefficients for the two sample groups were 0.65 and 0.70 respectively in the adaptation study.

## Procedure

The first step of the present study was obtaining permission from Frank Martela, the first author of the targeted scale (see Martela & Ryan, 2015). After obtaining the permission, the required ethics approval application was made to and obtained from the Research Ethics Committee of Dokuz Eylül University. The next step was translating the original form into Turkish by using Brislin's (1970) back translation method. Following this method, two Turkish researchers who each have a PhD in counselling and are both fluent in English translated the original form into Turkish separately. Afterwards, the two forms were examined, revised and combined into a single Turkish form. This form then was translated back into English by two other Turkish researchers who similarly each have a PhD in counselling and are both fluent in English. The same examination, revision and combination process was repeated for the back-translation form. This form was then sent to Frank Martela in order for him to confirm the back-translation. After Martela's confirmatory feedback, it has been concluded that the Turkish Brief Beneficence Satisfaction Scale (BBSS-TR) was accurately translated.

After the back-translation, all the scales were converted and combined into an online form through Google Forms. Three different forms were created with the three scales lined up differently to avoid any order effects. The scale orders (based on a 3 × 3 Latin square order) were as

follows: 1) BBSS-TR, SRA-TR & SHS-TR, 2) SHS-TR, BBSS-TR & SRA-TR and 3) SRA-TR, SHS-TR & BBSS-TR. Each form included a short debriefing about the overall aim of the study and confidentiality, an informed consent box and a demographics form at the very beginning. Then, the three links were shared via WhatsApp groups of postgraduate students.

After data collection, reliability and normality tests were executed. When the scales showed good reliability and the normality assumptions were satisfied, validity testing followed. The construct validity of the four-item and one-factor model was tested with confirmatory factor analysis on AMOS.  $\chi^2/df$  ( $p < 0.05$ ) between 0–2 indicated a good fit, whereas  $\chi^2/df$  ( $p < 0.05$ ) between 2–5 indicated an acceptable fit (Hooper et al., 2008). The cut-off values for RMSEA, GFI, CFI and SRMR were  $< 0.08$ ,  $> 0.90$ ,  $> 0.95$  and  $< 0.08$  respectively (Hu & Bentler, 1999). Convergent validity, then, was tested using correlation and simple linear regression analyses.

## Results

### Assumptions Testing

For univariate normality, skewness and kurtosis tests provided values between -1.96 and +1.96 (Field, 2005, p. 72). For the multivariate normality, the critical ratio value on AMOS was above 5.00 which indicated a non-normal distribution (Byrne, 2010, p. 104). After omitting six outliers, the critical value for multivariate normality was below 5.00 and both univariate and multivariate normality assumptions for confirmatory factor analysis were satisfied.

### Construct Validity

The preliminary DFA results were as follows:  $\chi^2 = 10.80$ ,  $df = 2$ ,  $\chi^2/df = 5.40$ , GFI = 0.98, CFI = 0.98, RMSEA = 0.12 and SRMR = 0.03. As can be seen, these results did not indicate an acceptable fit. Modification indices suggested correlating the errors of the item 1 and the item 2 (the item pair that was found to have the highest inter-item correlation, 0.64). After following this suggestion, the model showed quite a good fit, the summary of which was as follows:  $\chi^2 = 0.02$ ,  $df = 1$ ,  $\chi^2/df = 0.02$ , GFI = 1.00, CFI = 1.00, RMSEA = 0.00 and SRMR = 0.001. In addition, validity and reliability tests on AMOS (a plugin by Gaskin & Lim, 2016) further validated the good fit of the model, providing a CR (composite reliability) value of 0.84 and an AVE (average variance extracted) value of 0.57 (see Hair et al., 2014). The model can be seen below in Fig. 1.

Fig. 1 The BBSS-TR model

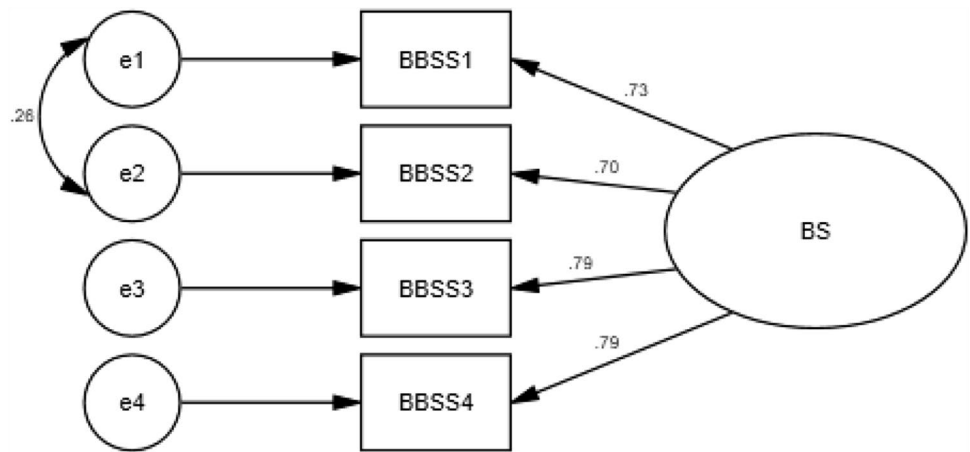

Chi-square = 0.20, df = 1, p-value = .89, RMSEA = .00

### Convergent Validity

To assess the convergent validity of BBSS-TR, altruism and subjective happiness were investigated along with beneficence satisfaction in the present study. Within this scope, the correlations among BBSS-TR, SRA-TR and SHS-TR were investigated. In addition, two simple linear regressions were executed in order to see how BBSS-TR predicted SRA-TR and SHS-TR separately. Findings showed that BBSS-TR demonstrates good convergent validity. In fact, the correlations between study variables were similar to those of the original study. Below are the correlations from both the present scale adaptation (Table 2) and the original scale development study (Table 3).

As can be seen in the tables, the Turkish adaptation of the Brief Beneficence Satisfaction Scale showed equivalent convergent validity in comparison to the original form. It is also important to note the well-being scales used in the two studies were not the same. Although subjective happiness and subjective well-being are similar constructs, they are also different, which could explain the slightly different correlation coefficients observed. Simple linear regression results further validated the convergent validity of BBSS-TR. The first simple linear regression that was calculated to predict SRA-TR based on BBSS-TR showed the following results:  $F(1,320) = 52.432, p < 0.000$  and  $R^2 = 0.141$ . Based on the  $\beta$  values, the regression equation for predicting SRA-TR from BBSS-TR was  $y$  (SRA-TR) =  $12.640 + 0.132x$  (BBSS-TR). On the other hand, the second simple linear regression that was calculated to predict SHS-TR based on BBSS-TR showed the following results:  $F(1,320) = 101.235, p < 0.000$  and  $R^2 = 0.240$ . Based on the  $\beta$  values, the regression equation for predicting SHS-TR from BBSS-TR was  $y$  (SHS-TR) =  $14.251 + 0.413x$  (BBSS-TR).

Table 2 Correlations between beneficence and other study variables

	M	SD	1	2	3
1. Beneficence	5.38	0.98	-		
2. Altruism	3.37	0.56	.38**	-	
3. Subjective happiness	4.41	1.16	.49**	.21**	-

\*\*  $p < .01$

Table 3 Correlations between beneficence and other variables in the original study

	M	SD	1	2	3
1. Beneficence	4.65	1.16	-		
2. Altruism	2.39	1.04	.34**	-	
3. Subjective well-being	4.12	2.56	.57**	.22**	-

\*\*  $p < .01$

### Reliability

The four items of BBSS-TR showed good reliability (Cronbach's  $\alpha = 0.85$ ). The data were also examined for potential gender and age differences. As assumed, no significant difference was found with gender. However, a significant positive correlation was found between age and beneficence satisfaction. Older participants showed more beneficence satisfaction than younger ones ( $r = 0.20, p = 0.00$ ). This finding was not seen as a threat to the reliability but a result of developmental change in adulthood (see Freund & Blanchard-Fields, 2014). Moreover, a significant positive correlation was found in the original study as well. The reliability test on AMOS further validated the internal consistency of the scale, showing a CR (composite reliability) value of 0.84.

In addition to Cronbach's alpha, item-total statistics were also performed to investigate reliability. The item-total correlations for the four items ranged between 0.68 and 0.71 showing good discrimination. Results indicated that exclusion of any item would lead to a decrease in Cronbach's alpha. Thus, BBSS-TR was shown to have good reliability. Further analyses showing item descriptives can be seen in Table 4.

The other two scales that were used for assessing convergent validity also showed adequate reliability. The Cronbach's alpha for SRA-TR was 0.85 and the Cronbach's alpha for SHS-TR was 0.74.

## Discussion

In the present study, psychometrical properties of the Turkish Brief Beneficence Satisfaction Scale were investigated. According to CFA results, the four-item and one-factor model showed quite a good model fit after the first modification on AMOS. The modification of correlating the errors of the item 1 and the item 2 was thought to be justifiable, in that this item pair had the highest inter-item correlation (0.64). Also, considering the similarity of the first two items in terms of their meaning (Item 1 = I feel that my actions have a positive impact on the people around me and Item 2 = The things I do contribute to the betterment of society), this modification was not seen as problematic.

Results also affirmed BBSS-TR's convergent validity. When correlations between study variables (namely, beneficence satisfaction, altruism and subjective happiness) were examined, similar correlations were found as to those in the original study. Moreover, the correlation between beneficence satisfaction and subjective happiness ( $r=0.49$ ,  $p<0.01$ ) were stronger than the correlation between altruism and subjective happiness ( $r=0.21$ ,  $p<0.01$ ), indicating that beneficence satisfaction is theoretically a separate construct that could be further investigated in well-being research. Measuring one's pro-social activity satisfaction, seemed to provide better results than measuring one's frequency of certain pro-social behaviors in explaining well-being.

Moreover, scores were tested for potential gender and age differences. As anticipated, no significant difference was found with gender. Nevertheless, a significant positive

correlation was found between beneficence satisfaction and age, as older participants showed more beneficence satisfaction than younger ones ( $r=0.20$ ,  $p=0.00$ ). This finding was seen as a result of common developmental change in altruism through adulthood that has been subject to developmental psychology research (see Freund & Blanchard-Fields, 2014). It also seems important to note that a significant positive correlation between beneficence satisfaction and age was found in the original study as well. Future research could further investigate this link using beneficence satisfaction as a construct. Lastly, the reliability tests showed good reliability for BBSS-TR with a Cronbach's alpha value of 0.85 on SPSS and a CR (composite reliability) value of 0.84 on AMOS.

In conclusion, it can be said that the Turkish adaptation of BBSS is a valid and reliable tool that is thought to contribute to well-being research both in theoretical and practical terms. In theory, it can help facilitate future positive psychology research in Turkey. Pro-social activity and one's satisfaction thereof can be an area of interest for positive psychology researchers in academics. So, the construct and its relationship to other constructs are yet to be studied. BBSS can be a helpful tool, in that, it can allow measuring one's overall satisfaction from pro-social activity quickly and subjectively. In practice, counselors and other mental health practitioners who work to facilitate individuals' well-being can make use of the scale in their well-being interventions. The scale can be used pre- and post-intervention to assess clinical outcome. It is also suggested that future research investigate the psychometric properties of the scale on different samples.

## Appendix

### BBSS-TR Sample Items

1. Eylemlerimin etrafımdaki insanlar üzerinde olumlu bir etkisi olduğunu hissedirim.
2. Yaptığım şeyler toplumun iyileşmesine katkı sağlar.
3. Item 3.
4. Genel olarak diğer insanların yaşamlarına olan etkim olumludur.

**Table 4** Item descriptives

	M	SD	Skewness		Kurtosis	
			Statistic	Std. Err	Statistic	Std. Err
BBSS1	5.50	1.12	-.73	.14	.64	.27
BBSS2	5.21	1.27	-.60	.14	.03	.27
BBSS3	5.16	1.23	-.42	.14	-.16	.27
BBSS4	5.65	1.09	-.81	.14	.67	.27



**Data Availability** The data are available in SPSS format.

**Code Availability** Not applicable.

## Declarations

**Conflicts of Interest/Competing interests** The authors have no conflicts of interest to declare.

**Ethics Approval** Ethics approval was obtained from the Research Ethics Committee of the authors' university.

**Consent to Participate** Informed consent was obtained from each participant.

**Consent for Publication** The authors give consent for the publication of the study.

## References

- Aknin, L., Barrington-Leigh, C. P., Dunn, E. W., ... Norton, M. I. (2013). Prosocial spending and well-being: Cross-cultural evidence for a psychological universal. *Journal of Personality and Social Psychology, 104*, 635–652. <https://doi.org/10.1037/a0031578>
- Aknin, L., Dunn, E. W., Whillans, A. V., Grant, A. M., & Norton, M. I. (2013b). Making a difference matters: Impact unlocks the emotional benefits of prosocial spending. *Journal of Economic Behavior & Organization, 88*, 90–95. <https://doi.org/10.1016/j.jebo.2013.01.008>
- Bekkers, R. (2006). Traditional and health-related philanthropy: The role of resources and personality. *Social Psychology Quarterly, 69*, 349–366. Retrieved from <http://www.jstor.org/stable/20141755>
- Brislin, R. W. (1970). Back-translation for cross-cultural research. *Journal of Cross-Cultural Psychology, 1*(3), 185–216. <https://doi.org/10.1177/135910457000100301>
- Byrne, B. M. (2010). *Structural equation modeling with AMOS: Basic concepts, applications, and programming* (2nd ed.). Erlbaum.
- Camerer, C. F. (2003). *Behavioral game theory: Experiments in strategic interaction*. Princeton University Press.
- Corral-Verdugo, V., Montiel-Carbajal, M. M., Sotomayor-Peterson, M., Frías-Armenta, M., Tapia-Fonllem, C., & Fraijo-Sing, B. (2013). *Psychological wellbeing as correlate of sustainable behaviors*. In C. García, V. Corral-Verdugo, & D. Moreno (Eds.), *Psychology research progress. Recent Hispanic research on sustainable behavior and interbehavioral psychology* (p. 27–40). Nova Science Publishers.
- Doğan, T., & Totan, T. (2013). Psychometric properties of Turkish version of the Subjective Happiness Scale. *The Journal of Happiness & Well-Being, 1*(1), 23–31.
- Dovidio, J. F., Piliavin, J. A., Schroeder, D. A., & Penner, L. A. (2006). *The social psychology of prosocial behavior*. Lawrence Erlbaum Associates.
- Feng, L., & Guo, Q. (2016). Beneficial effect of altruism on well-being among Chinese college students: The role of self-esteem and family socioeconomic status. *Journal of Social Service Research, 43*(3), 416–431. <https://doi.org/10.1080/01488376.2016.1242449>
- Field, A. (2005). *Discovering statistics using SPSS* (2nd ed.). Sage Publications, Inc.
- Freund, A. M., & Blanchard-Fields, F. (2014). Age-related differences in altruism across adulthood: Making personal financial gain versus contributing to the public good. *Developmental Psychology, 50*(4), 1125–1136. <https://doi.org/10.1037/a0034491>
- Gaskin, J., & Lim, J. (2016). "Model Fit Measures". AMOS Plugin.
- Grant, A. M. (2008). The significance of task significance: Job performance effects, relational mechanisms, and boundary conditions. *Journal of Applied Psychology, 93*, 108–124. <https://doi.org/10.1037/0021-9010.93.1.108>
- Gülaçtı, F. (2014). Investigating university students' predictors of psychological well-being. *International Journal of Academic Research, 6*(1), 318–324. <https://doi.org/10.7813/2075-4124.2014/6-1/B.43>
- Hair, J., Hult, T., Ringle, C., & Sarstedt, M. (2014). *A primer on partial least squares structural equation modeling (PLS-SEM)*. Sage Publications, Inc.
- Hooper, D., Coughlan, J., & Mullen, M. R. (2008). Structural equation modelling: Guidelines for determining model fit. *The Electronic Journal of Business Research Methods, 6*, 53–60.
- Hu, L.-T., & Bentler, P. M. (1999). Cutoff criteria for fit indexes in covariance structure analysis: Conventional criteria versus new alternatives. *Structural Equation Modeling, 6*(1), 1–55. <https://doi.org/10.1080/10705519909540118>
- İşgör, İY. (2017). Eğitim ve sağlık çalışanlarında psikolojik iyi oluş ve özgeciliğin incelenmesi. *Journal of Turkish Studies, 12*(6), 423–438. <https://doi.org/10.7827/TurkishStudies.11439>
- Lyubomirsky, S., & Lepper, H. S. (1999). A measure of subjective happiness: Preliminary reliability and construct validation. *Social Indicators Research, 46*, 137–155. <https://doi.org/10.1023/A:1006824100041>
- Martela, F., & Ryan, R. M. (2015). The benefits of benevolence: Basic psychological needs, beneficence, and the enhancement of well-being. *Journal of Personality, 84*, 750–764. <https://doi.org/10.1111/jopy.12215>
- Piliavin, J. A., & Siegl, E. (2007). Health benefits of volunteering in the Wisconsin Longitudinal Study. *Journal of Health and Social Behavior, 48*, 450–464. <https://doi.org/10.1177/002214650704800408>
- Riche, Y., & Mackay, W. (2010). PeerCare: Supporting awareness of rhythms and routines for better aging in place. *Computer Supported Cooperative Work (CSCW), 19*(1), 73–104. <https://doi.org/10.1007/s10606-009-9105-z>
- Rushton, J. P., Chrisjohn, R. D., & Fekken, G. C. (1981). The altruistic personality and the self-report altruism scale. *Personality and Individual Differences, 2*(4), 293–302. [https://doi.org/10.1016/0191-8869\(81\)90084-2](https://doi.org/10.1016/0191-8869(81)90084-2)
- Schwartz, C. E., Keyl, P. M., Marcum, J. P., & Bode, R. (2009). Helping others shows differential benefits on health and well-being for male and female teens. *Journal of Happiness Studies, 10*(4), 431–448. <https://doi.org/10.1007/s10902-008-9098-1>
- Sharma, S., & Singh, K. (2019). Religion and well-being: The mediating role of positive virtues. *Journal of Religion and Health, 58*(1), 119–131. <https://doi.org/10.1007/s10943-018-0559-5>
- Tekeş, B., & Hasta, D. (2015). Özgeciliik ölçeği: Geçerlik ve güvenilirlik çalışması. *Nesne Psikoloji Dergisi (NPD), 3*(6). <https://doi.org/10.7816/nesne-03-06-03>
- Thoits, P. A., & Hewitt, L. N. (2001). Volunteer work and wellbeing. *Journal of Health and Social Behavior, 42*(2), 115–131. <https://doi.org/10.2307/3090173>

**Publisher's Note** Springer Nature remains neutral with regard to jurisdictional claims in published maps and institutional affiliations.