

# A taxonomy for product shape analysis to integrate in early environmental impact estimations

Lina-María Agudelo<sup>1,2</sup> · Jean-Pierre Nadeau<sup>1</sup> · Jérôme Pailhes<sup>1</sup> · Ricardo Mejía-Gutiérrez<sup>2</sup>

Received: 8 June 2016 / Accepted: 24 June 2016 / Published online: 16 July 2016  
© The Author(s) 2016. This article is published with open access at Springerlink.com

**Abstract** Eco design and sustainable design are words with increasing relevance in the development of new products. One of the main reasons is the growing worry about the environmental issues that the planet is having nowadays, hence the demand for products with this aspect included. Now designers have the opportunity to adapt useful tools to estimate the environmental impact of a design concept in order to develop environmentally friendly products. However, it is only in the last stages of design process where design teams have enough information to calculate the impact of a proposal. This calculation is a tedious, expensive and demanding activity and involving a high level of knowledge about materials, manufacturing processes and eco-design strategies. For this reason, environmental impact estimations gain relevance in the early stages of the design process, where more risks can be taken with a lower cost. This article suggests a taxonomy to analyze product's shape; in order to offer a structured and systematic way of performing a morphology classification, being able to integrate this subjective aspect to other necessary variables needed to estimate the environmental impact. It offers a way to understand how shape, material and Manufacturing process are key aspects to make environmental

impact estimations of preliminary concepts during the Conceptual Design.

**Keywords** Eco-design · Sustainable design · Conceptual design · Shape · Material · Manufacturing process · Environmental impact · Impact estimation · Early design stages

## 1 Introduction

Every existing product has an environmental impact, even from early stages of its life cycle by consuming natural resources, energy and generating waste. This can be seen, for example, as raw materials are extracted from earth, product development also uses resources, distribution includes packaging elements that also have an impact, product operation consumes energy and finally product has to be discarded or disposed [30].

The environmental impact of a product can be classified in two main variables: energy and material. For some products such as automobiles and electronic products, the most significant effects are located in the “use stage”, because there is when energy consumption is higher. For other products such as clothing, furniture and static parts, the greatest effects can be found in the initial stages, where materials and production processes are defined [51].

Then, for designing products being composed of static parts, or a product that is made of one part, these two variables (materials and manufacturing process) are critical and need the designer's attention during the new product development process. This need to be tackled since the beginning, as early design phases enables more flexibility and downstream decisions are more constrained.

✉ Lina-María Agudelo  
lagudel8@eafit.edu.co

Jean-Pierre Nadeau  
jean-pierre.nadeau@ensam.eu

Jérôme Pailhes  
jerome.pailhes@ensam.eu

Ricardo Mejía-Gutiérrez  
rmejia@eafit.edu.co

<sup>1</sup> Arts et Métiers ParisTech, I2M, UMR 5295, 33400 Talence, France

<sup>2</sup> Design Engineering Research Group (GRID), Universidad EAFIT, 050022 Medellín, Colombia

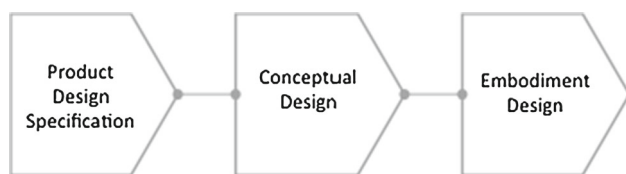

**Fig. 1** Preliminary design phase

This early design phase, so-called “Preliminary design” can be divided into three stages (See Fig. 1). The product specifications are collected and defined during the first stage. Physical solutions are generated to meet the design specification at the second stage. The final decisions on the dimensions, layout and shape of individual components and material to be adopted are made at the last stage [55].

“Conceptual Design” is therefore a complex process. To start, a product should be described by its function, behavior and structure [42] and on the other hand, it is difficult to obtain the complete and exact information/knowledge such as design requirements and constraints in the preliminary phase of product design process [53]. Product design is, in fact, a process of reducing the incompleteness in the description of conceptual design [34].

But it is in the preliminary design when the designer must face the uncertainty about the most critical variables; in this case as materials and manufacturing processes, which affect the weight, functionality and aesthetics of a product.

Furthermore, is in the preliminary design where the designer must transform these uncertain variables in design requirements [16]. But in these stages the designer doesn’t count with enough data or virtual tools for Life Cycle Impact Analysis to determine or choose a material or a manufacturing process while considering environmental impacts.

Moreover, environmental impact assessment tools are not suitable to be used in the conceptual design stage [29]. These tools give support only when detailed product information is available, but not when the designer is making decisions to build product concepts.

The fact of considering the environmental impact as part of the conceptual design process is a relatively new concept for many designers and companies; so, it is a new and unknown field to deal within design teams.

For instance, environmental impacts are getting more interest in nowadays markets, giving a new importance to preliminary variables related to environmental impact estimation (e.g., material, manufacturing processes and shape). These variables choices play a very significant role in determining the product’s environmental impact, because [31]:

- Extraction and processing of raw materials carries significant environmental impact.

- Materials choice determines feasible manufacturing processes and associated energy and material efficiency.
- Material mass can greatly influence energy consumption and CO<sub>2</sub> emissions in transport and use phases.
- The substances used in materials and their recyclability / reusability characteristics determine toxicity, restricted substance impacts, and the impact of a product at the end of its life.
- The CO<sub>2</sub> emissions associated with the material production and manufacturing phases: the lower mass is likely to lead to a large reduction in use phase CO<sub>2</sub> emissions and hence an overall improvement.

This variables need to be considered in a coherent and effective way, which does not substantially lengthen the design process, in order to help engineers and designers in decision-making in preliminary stages, trying to reduce the number of iterations in the design process.

## 2 Conceptual design stage

The Conceptual Design stage is the process to transform some intangible functional requirements in the functional domain to more tangible design parameters in the physical domain. The result of this stage is a design concept [27], which is a rough description of product shape, with possible materials and manufacturing processes.

The Conceptual Design stage begins with the “Product Design Specifications (PDS)” (See Fig. 2) which specifies what the product should include to satisfy the user requirements. Several design concepts are explored in terms of those design specifications and it can be considered as an interactive stage where, at each step, the number of concepts may be reduced by decision making process based on the PDS.

A design concept is usually expressed as a draft, sketch or as an approximate three-dimensional representation. It is, sometimes, accompanied by a brief conceptual description, in most cases, it supported on a functional analysis previously made.

Until now, designers cannot calculate the environmental impact of a product in the Conceptual Design stage, as it is based on factors that are not clear in this stage. Some can be estimated such as shape, material and possible manufacturing processes. However, these factors have an important environmental consequence. That is why, estimating the environmental impact at this conceptual stage may be an interesting indicator for concept selection, for improving decision-making in product design.

A complete exploration of design concepts on the first stages of the design process may reduce the development time if the designer start to include the evaluation of the environmental impact that the product can produce.

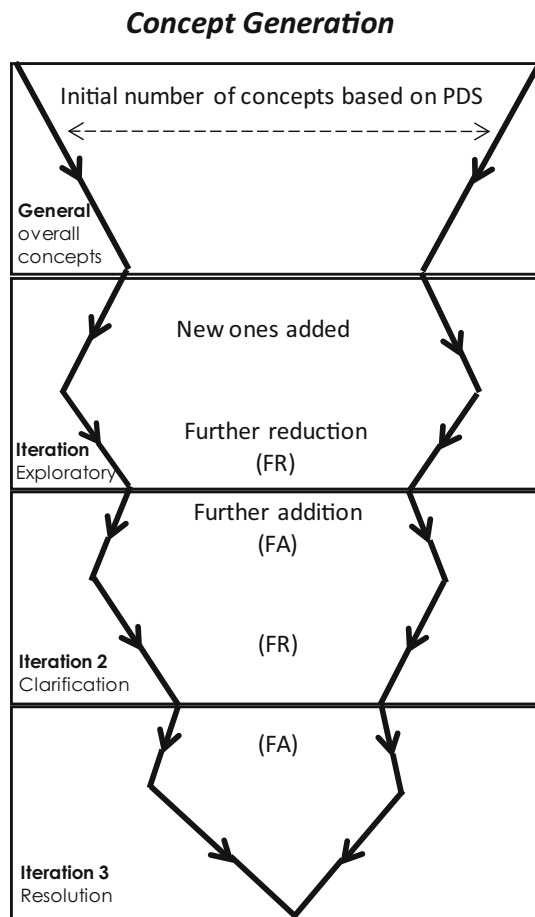

**Fig. 2** Concept generation process [9]

It is widely demanded that 80 % of the environmental impact of a product, has been ‘built in’ by the end of the conceptual design phase [15], because at this point, the designer has typically selected materials and possible manufacturing processes. These constrains not just could define the final economic cost, but also fix many of the environmental costs.

However, the possibility to estimate these impacts on conceptual design stages remains limited when designers find different methodologies of sustainable design, eco-design or the available software to calculate the impact. This limitations appears as, to use and evaluate the environmental impact, designers must know all the life cycle and some key variables should be defined. For instance, many of those variables are only defined until the Detail Design Stage where the product is complete.

Conceptual Design stage is interested in the search for innovative concepts as well as in the optimization of systems, parts or materials [41], however this stage in one of the design steps that is least supported in terms of environmental impact analysis. It is the transition from preliminary design phases to the final design stages, which is considered a major activity within the design process [1].

It leads from vague and imprecise parameters to precise and exact values. In contrast, many design methods only attempt to provide design support in the domain of well defined variables and parameters in which all values used during design must be known with certainty [2] shows which methodologies of eco design could be used, or not, during the different stages of the design process (Table 1), to see that the least supported stage talking in to the environmental issue is the conceptual design [2].

To identify in which stages of the design process can be apply the different eco design methods, it was created a nomenclature:

- (–) The tool provides no solution or decision-making aid at this stage.
- (+) The tool provides a solution or decision-making aid at this stage.
- (Δ) The tool provides partial solutions or help decision-making at this stage.

Consequently, the analysis shown [2] in reflects a lack of supporting tools for environmental impact analysis.

This leads to the idea of using upwards the variables that can be estimated in Conceptual Design. If those variables may be estimated, it can be inferred that an estimation of the environmental impact may be achieved enabling the analysis of different concepts by having an additional evaluation criteria.

### 3 The main variables of environmental impact estimation

The life cycle analysis emerges from the term “sustainable development”, that was first introduced in the report of the World Commission on Environment and Development that appeared as “Our Common Future” in 1987 [19].

Since then, sustainable development is steadily defined as “development that meets the needs of the present generation without compromising the ability of future generations to meet their own needs” [8].

The United Nations (UN), the European Union (EU) and many countries have adopted sustainable development as a policy principle, but it has become a central notion for many designers, engineers, companies, business councils and political parties [8].

Hence, the way to include the environmental impact analysis in product design is called in literature: environmental design, environmentally sustainable design, environmentally conscious design, etc., as a philosophy of designing physical objects and services to comply with the principles of social, economic, and ecological balance [38]. It can be also defined as the “systematic incorporation of considerations

**Table 1** Design methods and tools analysis [2]

		Eco design methods and tools					
		Qualitative			Quantitative		
		Okala Wheel	LiDs Wheel	MET matrix	Eco indicators 99	Simapro	Analysis
Design process stages	Clarifying of task	–	–	–	–	–	A1
	Conceptual design	+	–	–	–	–	A2
	Embodiment design	+	–	–	–	–	A2
	Detail design	+	Δ	Δ	Δ	Δ	A3

about a product, process and services life cycle” [48] supported by different methodologies and tools to calculate the environmental impact of a product.

Some characteristics of these methods are that some are based on another one, others don't have any documentation and some are completely subjective.

Most of these tools are useful to redesign products or as a comparison method. “The only method that could be applied to the conceptual design phase is the LIDS wheel, because is the designer from the beginning, who defined environmental and technical parameters that the new product will comply, though he begins with a comparison to an existing product or substitute” [31].

Within these methodologies and tools such as Matrix MET [23], Eco indicator 99 [23], Okala Wheel [52], SIMAPRO® [13], ECOAUDIT [17], a set of common variables may be determined to make a calculation of the environmental impact. These main variables are: materials, manufacturing processes, energy consumption (during product's use) and disposal of the product (or its parts).

Within the conceptual design phase, the methodology Design for Environment (*DfE*) begins by identifying the potential environmental effects of the product life cycle [15]. This allows design teams to consider environmental consequences in the Conceptual design phase. However, in the case of a redesign of product, relevant data can come from analysis of the effects of existing products or the product that wants to be redesigned.

According to the methodology *DfE*, the objects or products are divided into two groups, (the type of variables to consider depending on the nature of product).

For the first group of products as automobiles and electronic products, the most significant effects are located in the use stage, due to the energy consumption in this phase.

For the second group of products such as clothing, furniture and static products, the greatest effects can be found in the initial stages, where materials, production processes are determined [51].

For this proposal, the products of the second group were addressed, where the designer can analyze by parts or components without any type of energy for operation in the use

stage. This leads to analyze the relevant variables for this type of static products.

#### 4 Material, process and shape

The environmental effects that a product generates can be classified into two broad categories, energy and materials [50]. Therefore materials and processes are critical when designers need to calculate the environmental impact of a product. Thus, it cannot be generalized, as, for example, the environmental impact of a vehicle is not the same impact of an office furniture. A vehicle causes a greater effect over the environment, while the greater impact that furniture can cause, are present on the material extraction, production of the part and recuperation at the end of the product life cycle.

It is also necessary to know the amount of material that a product consumes, because the energy consumption during the manufacturing phase, the energy in the transport and the amount of material to be disposed at the end of the useful life of the product will depend on its mass.

The problem is that the variable “mass” is not determined in the early stages of the design process, but it does in later stages; however, this variable is closely linked to the volume of the product, but the volume is another uncertain variable in the design stage, which seeks to estimate the impact.

Nevertheless; quantity and volume, are directly related to the material selection and the shape, which it is a variable that the designer can contemplate and estimate in the early stages. Then, the shape becomes a third fundamental variable that can be manipulated to estimate the environmental impact of a product.

However, researching how the three variables are relate (materials, processes and Shape), it was found that the concepts and relations of “materials and processes” have been evaluated by some authors like (Ashby and Johnson, Material selection in mechanical design 2005) (Ashby, Materials and the environment: eco-informed material choice 2012) (Ashby, Materials selection in mechanical design 2004) [26, 28, 46] among others, who have developed a material and

process classification in order to express their understanding and management.

But the concept of “shape” does not count with an intuitive classification that allows easy understanding, much less with a common taxonomy among authors, even some times are difficult to interpret, and does not count with the notion of manufacturing processes inside taxonomies and they are not suitable to play an important role to estimate the environmental impact.

To understand better how to manage each variable to estimate the environmental impact, it is proposed to evaluate each variable and see the link between them.

#### 4.1 Variable: material

The materials selection plays a key role in the design process [12]. Materials allow products to function, to be durable, to have certain costs, to provide feedback and to give experiences among other things.

The material selection begins intrinsically in the early stages of the design process. That is why the need of supporting tools to guide the materials selection linked to the shape and manufacturing processes seems to be necessary.

The material selection is traditionally made by technical requirements like price, strength of material, temperature, stability, density, hardness, etc. [7]. However, for a successful product development the technical or physical demands are not enough factors like reputation, fashion, product, cultural aspects, etc. must also be taken into account when developing sustainable products [32]. As a result of metaphysical reasons like feelings for a certain material, the materials selection is often not easy [28].

The selection is typically an iterative process with subsequent optimization. A slight change in design with some cooling might change the situation so that material can be acceptable, which can result in a lower product price.

A material change in a certain product generally changes the design [28] and, in some cases, changes the shape, in order to optimize the characteristics or the manufacturing methods for a product (Fig. 3).

Engineering design draws on tens of thousands of materials and on many hundreds of processes to shape, join and finish them.

One of the aspects to optimize product design is to select the best couple of materials, maximizing its performance and minimizing its cost. The problem, still incompletely solved, is that of matching material and process attributes to design requirements (Ashby, *Materials selection in mechanical design*, 2004).

It is necessary to anticipate about how a material will behave once processed into a product when selecting materials [39]. Before ending up in a product, materials are undergoing many processes, that all influence the behavior,

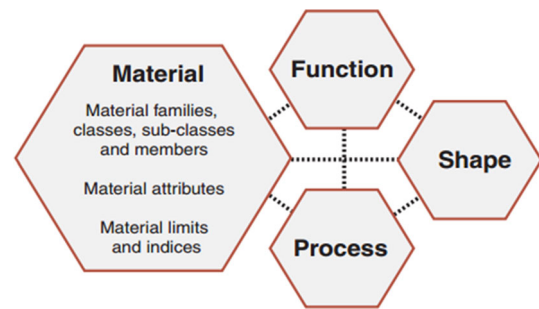

Fig. 3 Procedure for material selection [6]

such as shaping, joining, reinforcing or surfacing. Selecting materials is thus more than just picking a material from a catalogue and requires a thoughtful approach.

This is why; to find a consistent way to relate the materials, processes and shape, it becomes a complex process that requires high level of knowledge about the mechanical, physical and optical characteristics of materials. Additionally, it seems to be also necessary to know about all possible manufacturing process, their constraints and requirements.

Among the different classifications and taxonomies found in the literature about materials selection (Ashby and Johnson 2005) (Ashby, *Materials and the environment: eco-informed material choice*, 2012) (Ashby, *Materials selection in mechanical design*, 2004) [26, 28, 46], they were found few differences. This is why this article will focus on defining a shape taxonomy that can be related to any of the existing classifications of materials and manufacturing processes that showed to be well established.

As a starting point was taken as a reference, the classification proposed by Mike Ashby, who also is similar with the classification on CES<sup>®</sup> EDU PACK software for selection of materials. However, for the classification proposal (Fig. 4) it will have materials with environmental restriction information or eco indicator.

The main idea of have a material classification with an eco indicator is to relate this variable with the processes and possible shape, to create an interconnected classification.

These indicators were taken from the reference database *Ecoinvent*, punctually, *eco indicators 99*, *ReCiPe* and *CO2 footprint indicator* [45].

The recent rise of environmentally conscious design, which includes materials selection as a key element, mandates the development of new engineering tools for decision-making [20].

#### 4.2 Variable: manufacturing process

Manufacturing processes intends to give shape, surface finishing and jointing the product designed. They can be selected from a wide range of possibilities.

Family	Class	Type	Material		
Metals	Ferrous		Chromium steel 18/8		
			Cast iron		
	Non ferrous		Steel		
			Aluminium alloy		
Polymers	Thermoplastics	Semicrystalline	PET - Polyethylene terephthalate		
			PE - Polyethylene		
			PEHD - Polyethylene high density		
			PELD - Polyethylene low density		
			PP - polypropylene		
			PVC - Polyvinyl chloride rigid		
			PA 6,6 - Polyamide - Nylon		
			Thermosets	Amorphous	PS - polystyrene
					EPS - Expandable polystyrene
	HIPS - High impact polystyrene				
	PMMA - Polymethylmethacrylate pellets				
	PC - polycarbonate				
	PU - Flexible polyurethane				
	PUR - Rigid polyurethane				
	ABS - Acrylonitrile Butadiene Styrene				
	BR - Polybutadiene rubber				
	Ceramics			EPDM - Synthetic rubber	
				Glass	
Glass Fibre					
			Ceramic tile		
			Barbotine		

Fig. 4 Materials classification defined based on Ashby Classification

Every manufacturing process has several features and technical considerations when transforming a material into a solid part with the functional and formal characteristics.

Product characteristics that are of particular importance to the selection of the manufacturing processes are [40]:

- Size, shape, complexity
- Minimum and maximum dimensions
- Tolerances
- Surface finish
- Quantity of components to be produced

Within the state of the art of the different classifications and taxonomies of manufacturing processes, we found that most of the proposals as (Ashby & Johnson, Material selection in mechanical design, 2005), [26,46] had similarities when it comes to group processes.

For the manufacturing processes classification proposal (Fig. 5), were taken as a starting point the group of common words between the classifications studied like; process of shaping, joining, deformation and reduction.

For this variable, the classification proposal has also the restriction of eco indicator; for instance the classification has 18 different processes available.

However, the idea to include or see how to work with the processes without any eco indicator remains open for future discussion.

### 4.3 Variable: shape

Inside the study of the state of art of different classifications for materials, manufacturing processes and shape, we found a gap in the third variable more than the other two, which

Function	Type	Process		
Shaping	Reduction	Turning		
		Drilling		
		Milling		
	Deformation	Diecasting		
		Casting		
		Casting lost-wax		
		Impact extrusion, 1 stroke		
		Deep drawing		
		Sheet rolling		
		Injection moulding		
		Blow moulding		
		Extrusion		
		Thermoforming, with calendering		
		Glass Blowing		
		Bending		
		Punching with deformation		
		No Shaping	Join	Welding arc
				Welding gas

Fig. 5 Process classification defined based on CES® EDU PACK classification

Abbreviation	Increasing spatial complexity →							
	0 Uniform cross section	1 Change at end	2 Change at center	3 Spatial curvature	4 Closed one end	5 Closed both ends	6 Transverse element	7 Irregular (complex)
Round								
Blind								
Section, open SS (semi-closed)								
Tube								
Flat								
Spherical								

Fig. 6 Classification of component shapes according to their geometries [40]

leads to explore new classifications consistent with the others variables.

Several authors as Schey [40], Ashby [3], Thompson [46], Johnson [24] among others taxonomies proposals, do not get to a common, comprehensive and easy relationship between variables to understand how the designer can relate the three variables required for environmental analysis in a coherent way.

Schey for example, classified product shapes according to their geometric features (Fig. 6) and then used this to identify the particular machines or processes capable of producing these items [40]; introducing a relation between manufacturing processes and feasible shapes.

Johnson [24] on the other hand, divided the shapes into three main classes; Prism, Sheet and 3D shapes (Fig. 7); very

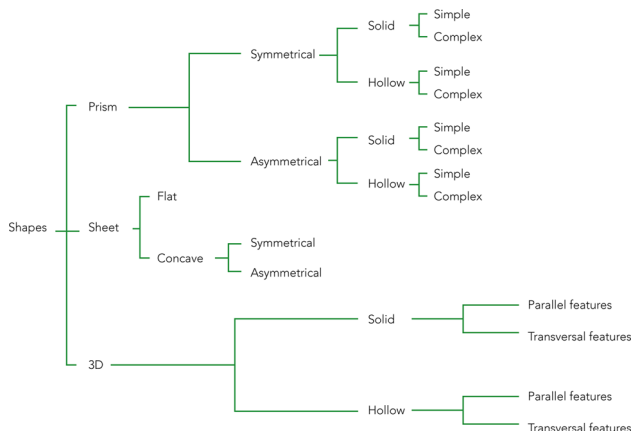

Fig. 7 Johnson’s classification of shape

different way of classify a shape against the Schey’s proposal for example.

There is a clear need here of a closer interaction between design engineers and manufacturing engineers, since gains in processing efficiency may be obtained or limitations on the use of particular machines or processes may be avoided by minor changes to original component design [40].

Often, the complexity of this shapes determines which processes can be considered to manufacture and in the wider sense, rising the shape complexity will reduce the range of applicable processes, and more critical, in some cases, increases the cost of designing and manufacturing.

Then, after having studied the different taxonomies of shape, it was found that there is not a system of classification of the shape accepted universally.

### 5 The relation of the main variables in different software and cad systems

Within eco-design tools, it is a set of software to make a Life Cycle Analysis (LCA), a number of variables and information about the product are required to be filled, so that the program can calculate the environmental impact. Consequently, designers can identify which is the stage that contributes the most to global impact.

Apart from this software, some Computer Aided Design (CAD) systems have also modules for sustainability analysis in their multiple tools for the design of a product, allowing to interact with some of the main variables for an environmental impact analysis.

In the following subsections, there is a small description and analysis of various CAD systems, Life Cycle Analysis software and Material Selection Software. The purpose is to identify in which stages of the design process they can be used, what information is required and how the software

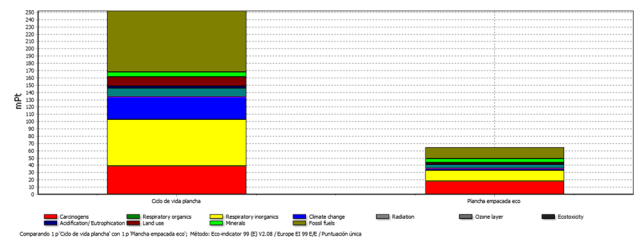

Fig. 8 SIMAPRO® software environment—impact comparison

makes the relationship between the principal variables (Material, Manufacturing process and Shape).

### 5.1 SIMAPRO®

The *SimaPro*® brings together the leading databases and methods of Life Cycle Impact Assessment (LCIA) available in the market and therefore is one of the software most widely used in the world to make a LCA [35].

The software allows access to approach LCA consequential of database ECOINVENT [13]. Moreover, it is easy to create or edit new processes and enter them in the product system.

It allows in-depth analysis on each of the flows of matter and energy and the precise identification of the source of environmental impacts [14].

The software is also little visual (Fig. 8), as in further analysis of the impacts, so to use it, the designer needs a flow chart of the production process for not to get lost in the information. The designer must know the different materials and processes involve in his product, the type of transport in the distribution stage and the energy consumption in the use stage. However, the software does not limit the way that the designer conceives their shapes.

### 5.2 ECO IT®

Eco IT® is a simple and fast tool for LCA; the evaluation is made based on the Eco-indicators 95 and 99 methods [30] providing a guide and not absolute values, to search an improvement [23].

The bigger score, the greater impact. For this analysis, the software uses two types of ecological indicators:

- Based on the RECIPE [23] methodology, provide a vision of life-cycle assessment simplified, taking into account most of the categories of environmental impacts.
- The Intergovernmental Panel on Climate Change (IPCC) [21] provides a vision of product carbon footprint, giving the results in kilograms of CO2 equivalents.

The program has a main window with 4 tabs as follows:

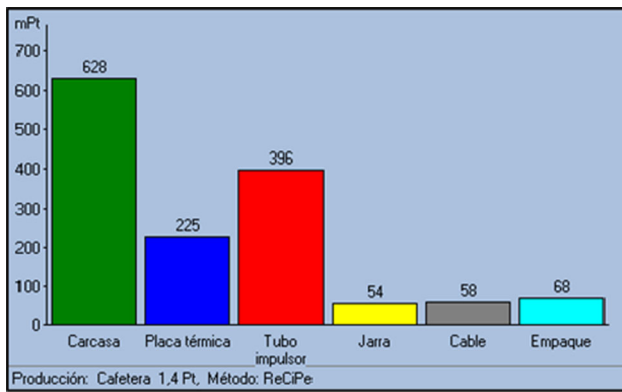

Fig. 9 ECO IT® Impact graphic

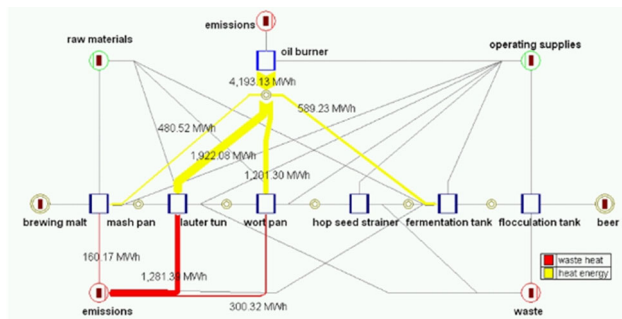

Fig. 10 UMBERTO® software environment

- Lifecycle: In which the product life cycle is described.
- Production: Here the materials and processes required are specified, the different parts of the product, energy and transportation.
- Use: all types of energy and transport involving the products are shown.
- Elimination: is where the stage of disposal of the product or its different parts is established.

The results show the environmental impact of the life cycle stages and graphic scores by default (Fig. 9), this impact in every line shown with a red bar (positive value) or yellow (negative value).

### 5.3 UMBERTO®

UMBERTO® is a software for modeling, calculating, displaying and evaluating material flows and energy flows and thus allows to understand complex processes in a simple way through graphs (Fig. 10).

It is ideal for Life Cycle Analysis and for the cost analysis and also has additional functions to lower costs and achieve efficiency in industrial processes.

UMBERTO® for Carbon Footprint (Fig. 11) is another presentation of the program which can calculate the carbon footprint of a company, a process or a product and then ana-

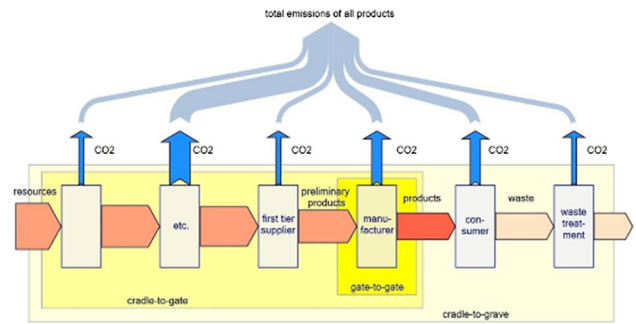

Fig. 11 UMBERTO® Carbon Footprint software environment

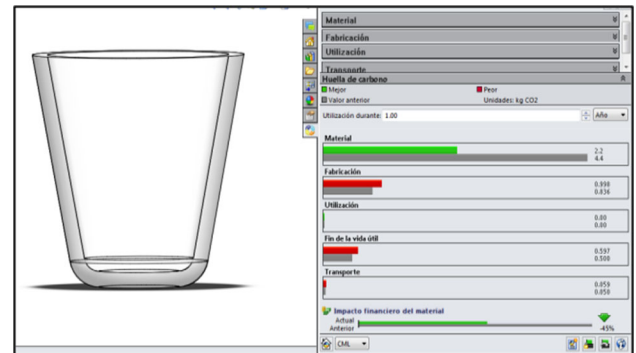

Fig. 12 Carbon footprint analysis

lyze it in detail and thus find efficient corrective measures to achieve a significant reduction in carbon footprint.

It is also one of the most that cares about the look of the interface and bases its analysis on the construction of a flowchart of processes, materials and energy [14] and allows defining system steps individually and analyzing them, however the designer does not count with an interface to manage the shape of its product.

### 5.4 Solidworks®

Is a software CAD that offers a specialized module to test the environmental impact of a product design. “SolidWorks® sustainability” analyzes four traditional indicators for the LCA: carbon print, energy consumption and the impact that it causes in water and air [10].

The key variables for this analysis are the material, the process, the region where it is manufactured, the region where it is used, the transport and the end of the product life cycle. With these variables, SolidWorks® calculates the environmental impact indicators.

However, SolidWorks® Sustainability allows selecting any kind of material for any kind of product, as well as any kind of process for any kind of material and product.

Figure 12 shows how SolidWorks® deliver the results to analyze the carbon foot print without any kind of restrictions.



SolidWorks® Sustainability is a useful tool for the detail design stages or for when designers are going to redesign a product because it is necessary to have a lot of details of the product life cycle. Additionally, in product development stages it helps to prove the environmental impact that a product is going to generate, but if designers want to use it in conceptual design stages it requires a lot of time to make the 3D model and the variables to get the environmental impact are not defined yet.

The CAD software's can be used in different design stages, however, they are more suitable in detail design stages; because early stages require high abstraction level that does not fit to the parametric needs of a CAD model [44]. In the conceptual design stages, sketches allow designers to be inaccurate and abstract, it opens the path to speed, flexibility and fluency. While CAD systems forces designers to provide details [54].

### 5.5 CES® EDU pack

CES® EDU PACK provides a comprehensive database of materials and process information, powerful materials software tools, and a range of supporting textbooks, lectures, projects, and exercises to know how to select the material in a product.

The software has a unique, comprehensive, browsable information resource in Materials and Processes Database.

This covers engineering materials (ceramics, metals and alloys, composites, polymers and elastomers) and processes (shaping, joining, surface treatment). Missing values are estimated allowing the comparison, analysis, and selection of materials and processes.

For each material or process, the database contains descriptive text, explanatory images, and technical, economic, and eco properties, which can be applied in highly visual ways, giving to the user a deep understanding of the relevance of these properties to their applications [18].

#### 5.5.1 ECOAUDIT

EcoAudit technology is a module that is within CES® EDU PACK, and applies eco materials, and process data to provide a rapid estimate of the energy and CO<sub>2</sub> impact of a product over its lifecycle. The user can quickly compare the environmental performance of alternative product designs [17].

The designer must choose the materials and processes involved in their design and also see the possibilities of shapes.

Many processes involve rotation or translation of a tool or of the material, directing our thinking towards axial symmetry, translational symmetry, uniformity of section, and such like.

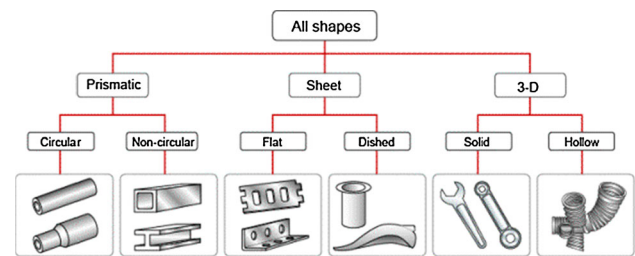

Fig. 13 The classifications of shape [17]

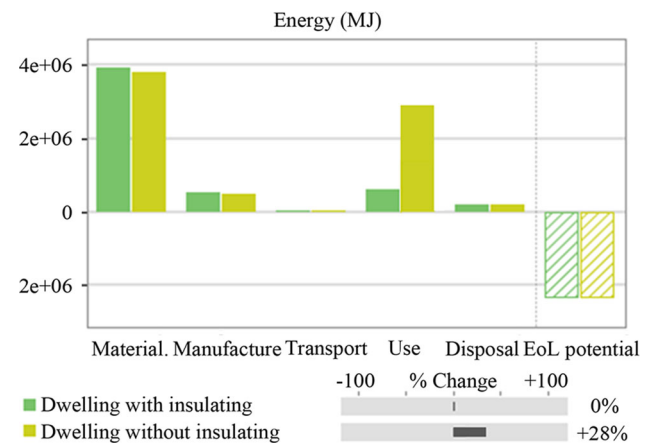

Fig. 14 ECO AUDIT software environment [18]

For example *turning* creates axisymmetric (or circular) shapes; *extrusion*, *drawing*, and *rolling* make prismatic shapes, both circular and non-circular. *Sheet-forming* processes make flat shapes (*stamping*) or dished shapes (*drawing*).

Certain processes are adapted to make 3-dimensional shapes – *casting and molding*, for example – and among these some can make hollow shapes whereas others cannot [17].

The shaping records of the CES database Fig. 13. The classifications of shape [17] (Fig. 13) identify the families of shape that each process can give, but also without any restrictions.

The CES ECO AUDIT system is intended to provide understandable information (see Fig. 14) in whatever format the designer chooses to use it. For this reason values are included for two indicators where they are available: the Dutch eco-indicator (95–99) and the Swedish EPS indicator [3].

At the end of the exploration of the main variables in different CAD systems, LCA Software and Material Selection Software, we found that some software relate directly the variable process with the materials, but generally they fall short in linking the variable of shape; however, the software that attempts to relate the three variables is ECO AUDIT module in CES® EDU PACK system, showing a short, sim-

ple taxonomy, that displays some general characteristics to which the designer could get; nevertheless, this does not guide the decision-making or shows any restrictions with which the designer must work.

That is why we seek to create a taxonomy of shape that allows us to relate the three main variables in a consistent way, to delimit the possibilities for the designer to play, while an additional parameter for future evaluation of their concepts is acquired.

## 6 Shape taxonomy proposal and external validation

For this first approach, our taxonomy proposal shape is used to parts without surface finishing processes or interaction or assembly processes, this level of detail, can be evaluated in future stages in the design process, such as design detail, where the designer has tools to evaluate it.

So we worked on classifying forms of static objects (products that do not need external energy to function), single process to get to its shape and with one material involved.

If the designer has a product composed of several parts, he could use the taxonomy to classify its shape dividing the product by parts and if the part is analyzed as a whole part, the part is mono material.

To define in a clear way our taxonomy, it can be divided into two main blocks. The first block is for *hollow* parts (Table 2) and the second one for *solid* parts (Table 3).

Each block has a group of 6 general shape characteristics that define a shape by grouping them.

Is important to highlight in order to obtain our taxonomy, it was considered the notion of manufacturing processes, this means, geometric features that manage the different processes available.

To understand better how each of the six characteristics is explained, a definition of each word or characteristic was carried out as follows:

1. First characteristic (Fig. 15): the part is solid or hollow
  - Hollow: convex or concave part with some variable thickness
  - Solid: firm part, full, which is slightly concave or convex
2. Second characteristic (Fig. 16): the axis of the part (preferential axis) is straight or curve.
3. Third characteristic (Fig. 17): the transversal section (perpendicular section to the preferential axis) is constant or variable
  - Variable: with changes in shape or size along the preferential axis.

**Table 2** Hollow parts block

Hollow	Straight	Constant	Simple	Plane	With surface details
					Without surface details
				Curve	With surface details
					Without surface details
				Circular	With surface details
					Without surface details
			Complex	Plane	With surface details
					Without surface details
				Curve	With surface details
					Without surface details
		Variable	Simple	Plane	With surface details
				Curve	With surface details
					Without surface details
			Complex	Plane	With surface details
					Without surface details
				Curve	With surface details
					Without surface details
	Curve	Constant	Complex	Plane	With surface details
				Curve	With surface details
					Without surface details
		Variable	Simple	Curve	With surface details
				Circular	With surface details
					Without surface details
			Complex	Plane	With surface details
					Without surface details
				Curve	With surface details
					Without surface details

4. Fourth characteristic (Fig. 18): the thickness of the transversal section can be simple or complex

- Simple: when there is a single thickness in cross section
- Complex: when there are different thicknesses in the cross section

5. Fifth characteristic (Fig. 19): the boundaries of the transversal section of the part are plane, curve or circular.

- If the part has all the contour planes, the part is called one part with plane contours.
- If the part has at least a curved contour, the part is called one part with curved contours.
- If the part has a symmetrical circular contour, the part is called one part with circular contours.

**Table 3** Solid parts block

Solid	Straight	Constant	Simple	Plane	With surface details
					Without surface details
				Curve	With surface details
					Without surface details
			Complex	Circular	With surface details
					Without surface details
			Variable	Plane	With surface details
					Without surface details
			Simple	Circular	With surface details
					Without surface details
			Complex	Plane	With surface details
					Without surface details
Curve	Variable	Complex		Plane	With surface details
					Without surface details
				Curve	With surface details
					Without surface details
			Constant	Simple	Curve
					With surface details
					Without surface details
					Circular
					With surface details
					Without surface details
			Complex	Plane	With surface details
					Without surface details
				Curve	With surface details
					Without surface details

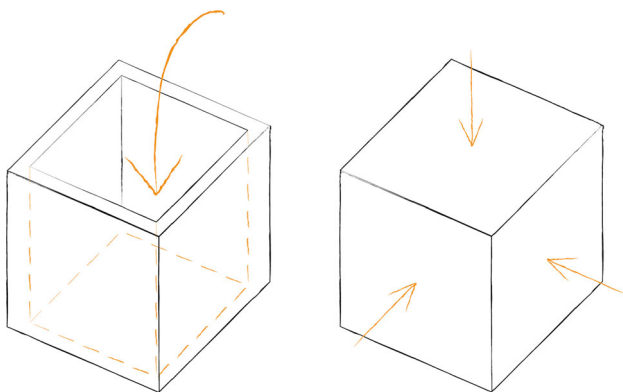

**Fig. 15** Hollow and Solid parts example definition

6. Sixth characteristic (Fig. 20): the part has surface details

- Surface details are small changes in the surface given by the same process that gives shape.

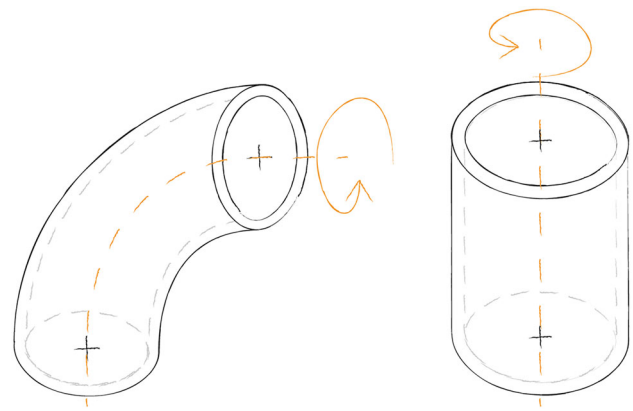

**Fig. 16** Preferential axis example definition

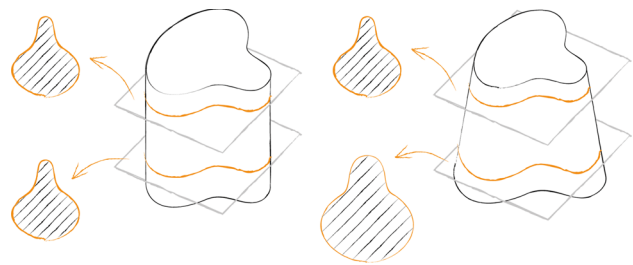

**Fig. 17** Transversal section example definition

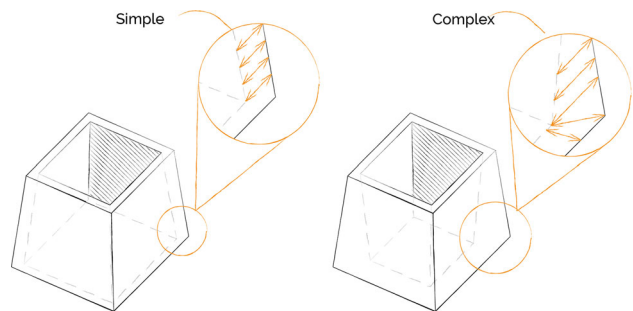

**Fig. 18** Thickness example definition

At the end it is possible to conclude with a general table (Table 4) with the possible characteristics that the designer would find.

**6.1 External validation**

For this first external validation, was attended by 15 members of Eco SD, Network with different research disciplines between eco design, mechanics and innovation, which is a French association which the main objective is to encourage collaboration between academic and industrial researchers in order to create and spread advanced knowledge in the eco-design fields.

For the validation were taken into account the match in each characteristic and the match in the whole classification by each part respect to classification defined in the internal

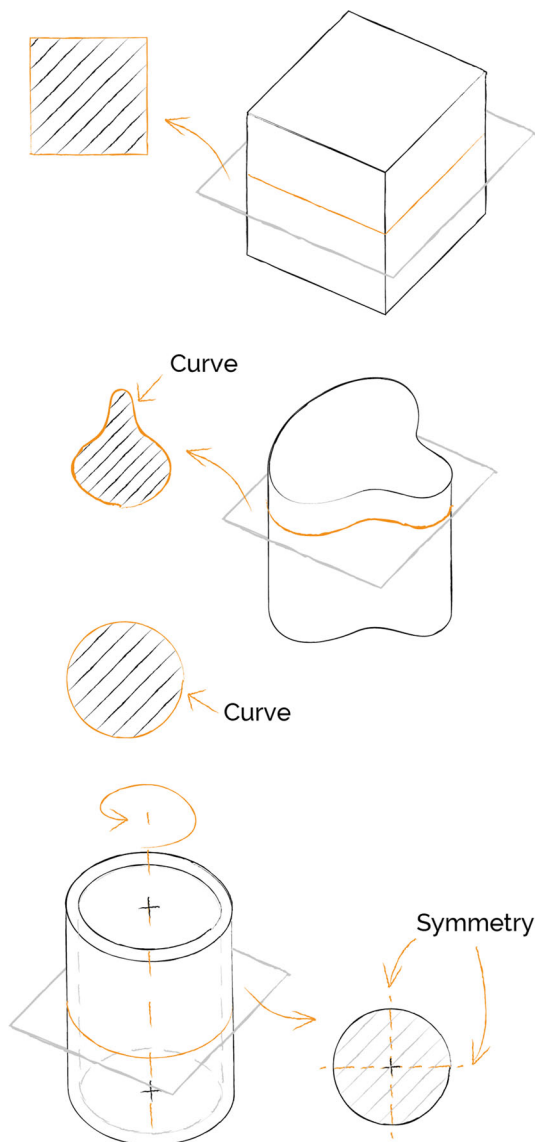

Fig. 19 Boundaries example definition

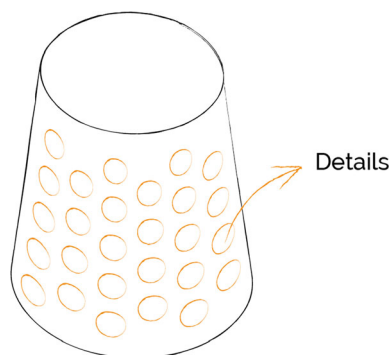

Fig. 20 Surface details example definition

validation, to observe on which characteristic becomes more difficult to coincidence and to verify if the group of words was the right to describe a shape.

Table 4 General Shape taxonomy

Piece	Preferential axis	Transversal section	Thickness	Boundary	Details
Hollow	Straight	Constant	Simple	Plane	With surface details
Solid	Curve	Variable	Complexe	Curve	Without surface details
				Circular	

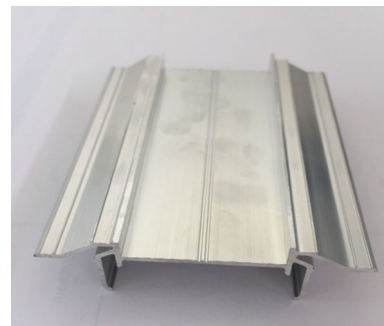

Fig. 21 Part 1 example analyzed

- For the first part (Fig. 21), a high degree of coincidence was had with regard to the classification defined (Table 5); the characteristic that had fewer coincidence, was the sixth one, where there is defined if the part has or do not have detail in the surface. The shaded areas represent those characteristics where there was no coincidence.

For 8 of the assistants, the part was possessing details for having a few small grooves in one of his sides (Figs. 22, 23); whereas inside the internal classification (Fig. 24), the part was not possessing details in the surface. To finally have a match for characteristics above 80 % (Fig. 25).

- For the second part (Fig. 22), the coincidence was major that in the first one (Table 6 Characteristics coincidence - Part 2) nevertheless the characteristic that present ambiguities was the third one, where the transversal section is defined.

8 of the members assistants defined the section as constant, without noticing that the part had changes in the section in the later face of the part. That is why in the classification defined for the comparison (Fig. 26), the part has a variable section.

**Table 5** Characteristics coincidence—part 1

Piece	Preferential axis	Transversal section	Thickness	Boundary	Details
Solid	Straight	Variable	Simple	Plane	Without
Hollow	Straight	Variable	Complex	Plane	With
Hollow	Straight	Variable	Complex	Plane	With
Solid	Straight	Variable	Simple	Plane	With
Solid	Straight	Variable	Simple	Plane	Without
Solid	Straight	Variable	Simple	Plane	Without
Solid	Straight	Variable	Simple	Curve	Without
Solid	Straight	Variable	Simple	Plane	Without
Solid	Straight	Variable	Simple	Curve	Without
Solid	Straight	Variable	Simple	Plane	With
Solid	Straight	Variable	Simple	Plane	Without
Solid	Straight	Variable	Simple	Plane	With
Solid	Straight	Variable	Simple	Plane	With
Solid	Straight	Variable	Simple	Plane	Without
Solid	Straight	Variable	Complex	Plane	With
Hollow	Straight	Variable	Complex	Plane	With



**Fig. 22** Part 2 example analyzed



**Fig. 23** Part 3 example analyzed

In total for the analysis of this part, the match by characteristics was 86 % (Fig. 27) exceeding the coincidence of the first part analyzed.

- For the last part (Fig. 23) that was evaluated, the coincidence was minor that the first two analyzed parts. The

Piece	Preferential axis	Transversal Section	Thickness	Boundary	Details
Hollow	Straight	Constant	Simple	Plane	with surface details
	Curve	Variable	Complex	Curve	
Solid	Curve	Variable	Complex	Circular	without surface details

**Fig. 24** Internal classification example—part 1

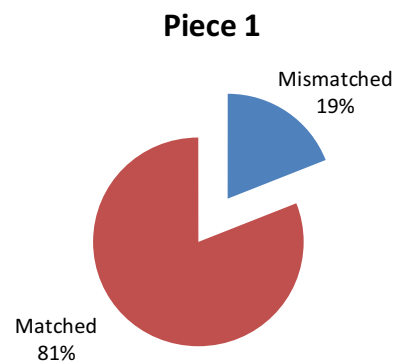

**Fig. 25** Evaluation by characteristics—part 1

characteristic that had major discrepancies was the second one, where the preferential axis of the part is defined.

In the internal validation (Fig. 28) there was defined that the part has a preferential straight axis, but for the majority of the assistants; the part has a preferential curved axis (Table 7 Characteristics coincidence—part 3); what shows an ambiguity in the definition of the preferential axis and the surface in this specific case, because the part has a curved surface,

**Table 6** Characteristics coincidence—part 2

Piece	Preferential axis	Transversal section	Thickness	Boundary	Details
Hollow	Straight	Variable	Complex	Curve	With
Hollow	Straight	Variable	Complex	Curve	With
Hollow	Straight	Variable	Complex	Curve	With
Hollow	Straight	Variable	Complex	Curve	With
Hollow	Straight	Variable	Simple	Curve	Without
Hollow	Straight	Variable	Complex	Curve	With
Hollow	Straight	Constant	Complex	Curve	With
Hollow	Straight	Variable	Complex	Curve	With
Hollow	Straight	Constant	Simple	Curve	With
Hollow	Straight	Constant	Simple	Curve	With
Hollow	Straight	Variable	Complex	Curve	With
Hollow	Straight	Constant	Simple	Curve	With
Hollow	Straight	Constant	Complex	Curve	With
Hollow	Straight	Constant	Complex	Curve	With
Hollow	Straight	Constant	Complex	Curve	With
Hollow	Straight	Constant	Complex	Curve	With
Hollow	Straight	Constant	Complex	Curve	With
Hollow	Straight	Constant	Complex	Curve	With

Piece	Preferential axis	Transversal Section	Thickness	Boundary	Details
Hollow	Straight	Constant	Simple	Plane	with surface details
				Curve	
Solid	Curve	Variable	Complex	Circular	without surface details

**Fig. 26** Internal classification example—part 2

Piece	Preferential axis	Transversal Section	Thickness	Boundary	Details
Hollow	Straight	Constant	Simple	Plane	with surface details
				Curve	
Solid	Curve	Variable	Complex	Circular	without surface details

**Fig. 28** Internal classification example—part 3

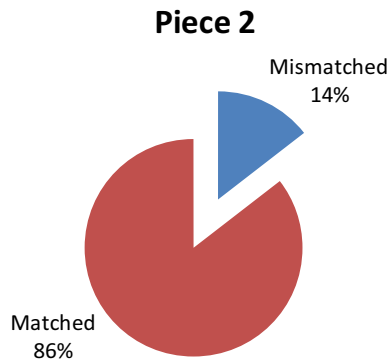

**Fig. 27** Evaluation by characteristics—part 2

which can lend itself to doubt as to the type of the axis that has the part.

At the end; this part, had the lowest match between the 3 parts analyzed (Fig. 29); because of possible ambiguity presented in the characteristic that defines the preferential axis.

At the end of the validation exercise, we can see that good matches in the different parts are found, and also that the group of words defined for the taxonomy it is understandable for different disciplines.

However, we should continue validating with people who have a designer profile, who can associate the shape of a part with the notion of manufacturing processes in a more conscious way, to try to achieve higher matches by characteristics, hoping to reach a complete coincidence on the definition of the form.

The taxonomy proposal can be related to the materials and manufacturing processes, in order to complete the main variables needed for estimating the impact on the conceptual stages of design process, to provide design guidelines and a criterion for materials and processes selection to achieve environmentally conscious design.

The main idea to define a shape taxonomy is be able to create an interactive design tool that relate the main variables to estimate the environmental impacts, to give a support in the decision-making in early design stages, to reduce the iterations and redefinitions about the product.

### 7 Further work

It is proposed to build a database that relates in a interactive way, the main variables for the estimation of environmental impacts in the early stages of the design process, bringing

**Table 7** Characteristics coincidence—part 3

Piece	Preferential axis	Transversal section	Thickness	Boundary	Details
Solid	Straight	Variable	Complex	Curve	Without
Solid	Curve	Constant	Simple	Curve	Without
Solid	Curve	Constant	Simple	Curve	Without
Solid	Curve	Variable	Complex	Curve	With
Solid	Curve	Variable	Complex	Curve	Without
Solid	Curve	Constant	Simple	Curve	Without
Solid	Curve	Variable	Complex	Curve	With
Solid	Curve	Variable	Simple	Plane	Without
Solid	Straight	Variable	Simple	Curve	Without
Solid	Curve	Variable	Complex	Curve	Without
Solid	Curve	Variable	Complex	Curve	Without
Solid	Curve	Variable	Simple	Curve	Without
Solid	Curve	Variable	Simple	Curve	Without
Solid	Curve	Variable	Complex	Curve	Without
Solid	Curve	Variable	Complex	Plane	Without
Solid	Straight	Variable	Complex	Curve	Without

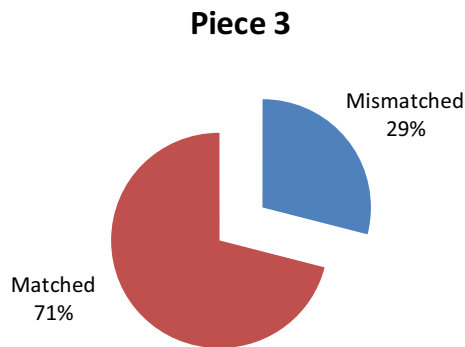
**Fig. 29** Evaluation by characteristics—part 3

together the classifications of processes, materials and Shape taxonomy proposed, allowing to guide the decision-making on materials, processes and shape of a product concept to expert designers, and designers with no experience.

Define the volume estimation method, in order to relate the main variables to estimate the environmental impacts of static objects in early stages in the design process.

Describe how the database can evolve the design process, that takes place in the preliminary stages, and see how it connects to the following steps and develop an interactive design tool that relate the main variables to estimate the environmental impacts.

## 8 Conclusions

Eco design requires time and it has to be thought as an additional design activity. This requires a deep knowledge of materials, types of energies, processes, packaging, and life-

time by the designer, leading at the end it is translate it into time and rework in the design process to arrive at a product with environmental characteristics properly evaluated.

In the design process to develop a product, the conceptual design stage plays an important role as been one of the critical ones, mainly because it is at this point where are define the alternatives that will be elaborated further. That's why is at this stage it is important to start making decisions related to the environment, and in a certain way it can be controlled safely in the further stages. These advanced decisions can improve the final result in terms of environmental performance, reducing iterations that may appear in subsequent stages.

Before the product is designed, the designer should list the required properties, perhaps in collaboration with the user. During this design period when the product is created, the designer must play with the different properties to create a pull of concepts that must be evaluated later from different parameters, it is then important that the designer has the environmental parameter in the design stage as an additional parameter to evaluate their concepts, and thus advance to the next stage with concepts that allow you to reduce future iterations in the final stages of the design process.

Despite the fact that we found different taxonomies of shape, none of these was relating in a coherent way with the other two principal variables, they do not also have a group of understandable words to identify the group of characteristics and do not mark the direct relation with the possibility or restrictions of the processes. That's why it is important to guide the decision-making process of the designer about materials, processes and shape in a coherent way to get the detailed design of their product.

Among the different LCA software studied, just ECO AUDIT module show a short simple taxonomy of shape, that displays some general characteristics to which the designer could get; nevertheless, this does not guide the decision-making or shows any restrictions with which the designer must work.

The idea of the taxonomy proposal is to help the designer to consider the different *triad* options (material, process, shape) and be aware of possible restrictions on the shape that must be handled in its design.

Although our proposed taxonomy shape, manages to define the different characteristics that describe the shape of a product with different materials and processes; It is obvious that having the restrictions of environmental indicators for processes and materials; we are leaving for the moment a highly relevant processes in the present industry, as additive manufacturing, who covers a large number of different characteristics of shape.

And in other CAD systems that were evaluated as SolidWorks® and Inventor, where the user can assess the environmental impacts of the product, the designer must generate detailed 3D modeling, and does not restrict in a coherent way according to their shape, processes and materials possible for the product. Which does not limit their field and does not guide decision-making regarding the main variables.

**Acknowledgements** Thanks to ARTS ET MÉTIERS PARISTECH University and EAFIT University for funding and give academics support to this study in their research groups.

**Open Access** This article is distributed under the terms of the Creative Commons Attribution 4.0 International License (<http://creativecommons.org/licenses/by/4.0/>), which permits unrestricted use, distribution, and reproduction in any medium, provided you give appropriate credit to the original author(s) and the source, provide a link to the Creative Commons license, and indicate if changes were made.

## References

- Abeln, O.: CAD-Systeme der 90er Jahre—vision und realität. (VDI-Verlag, Éd.) Datenverarbeitung in der Konstruktion **861**, 85–100 (1990)
- Agudelo, L.-M., Mejía-Gutiérrez, R., Nadeau, J.-P., Pailhes, J.: Life cycle analysis in preliminary design stages. (Springer, Éd.) Res. Interactive Des. Mech. Des. Eng. Adv. Manuf. **4**, 53 (2016)
- Ashby, M.: Materials and the environment: eco-informed material choice. (Elsevier, Éd.) Oxford: Butterworth-Heinemann (2012)
- Ashby, M.: Materials selection in mechanical design (éd. 2nd). (Elsevier, Éd.) Oxford: Butterworth-Heinemann (1999)
- Ashby, M.: Materials selection in mechanical design (éd. 3). (Elsevier, Éd.) Oxford: Butterworth-Heinemann (2004)
- Ashby, M., Johnson, K.: Material selection in mechanical design (éd. 3, Vol. 30). (Elsevier, Éd.) Oxford: Cambridge University Press (2005)
- Brechet, Y., Bassettib, D., Landrua, D., Salvo, L.: Challenges in materials and process selection. (Elsevier, Éd.) Prog. Mater. Sci. **46** (3–4), 407–428 (2001)
- British Standards Institutions.: Environmental management—life cycle assessment. Principles and framework. (BSI, Éd.) London (2006)
- Buxton, B.: Research and advanced development feeding product design, sketching user experiences (interactive technologies). (Elsevier, Éd.) San Francisco (2007)
- Corp, Solid Works.: Guía del diseño sostenible. (Dassault Systèmes) Solid Works Sustainability (2015). <http://www.solidworks.es/sustainability/>. Accessed 30 Apr 2015
- Corp, Solid Works.: Solid Works. (Dassault Systèmes) Solid Works (2015). <http://www.solidworks.es>. Accessed 30 June 2015
- Doordan, D.: On Materials. (M. I. Technology, Éd.) Design issues, **19** (4), 3–8 (2003)
- Ecoinvent.: Ecoinvent centre. Swiss Centre for Life Cycle Inventories (2013). <http://www.ecoinvent.org/>. Accessed 30 Aug 2013
- EnCiclo Sustainable Solutions.:5 SOFTWARES PARA REALIZAR ANÁLISE DE CICLO DE VIDA (ACV) DOS SEUS PRODUTOS. (DISQUS) EnCiclo Sustainable Solutions (2015). <http://blog.enciclo.com.br/5-software-para-realizar-analise-de-ciclo-de-vida-acv-dos-seus-produtos/>. Accessed 28 Oct 2015
- EPA, US Environmental Protection Agency.:Design for the Environment (DfE) Workplace Best Practices. EPA (2008). <https://www.epa.gov/saferchoice/design-environment-dfe-workplace-best-practices>. Accessed 22 Nov 2015
- Giachetti, R. E., Young, R. E., Roggatz, A.: A Methodology for the reduction of Imprecision in the engineering process. (Elsevier, Éd.) Eur. J. Oper. Res. **100** (2), 277–292 (1997)
- GRANTA Design.: CES EDU PACK. Retrieved 11 15, 2015, from Granta Material Intelligence: <http://www.grantadesign.com/education/edupack/> (2011)
- GRANTA design.: Material inspiration. (Granta) Granta (2015). <http://www.grantadesign.com>. Accessed 02 Oct 2015
- Horne, R., Grant, T., Verghese, K.: Life cycle assessment . Principles, practice and prospects. (CSIRO, Éd.) Collingwood (2009)
- Huang, H., Liu, Z., Zhang, L., Sutherland, J. W.: Materials selection for environmentally conscious design via a proposed life cycle environmental performance index. (Springer-Verlag, Éd.) Int. J. Adv. Manuf. Technol. **44**(11–12), 1073–1082 (2010)
- IHOBE.:European Environmental Services Platform. Retrieved 10 28, 2015, from Análisis del ciclo de vida y huella de carbono: <http://www.euresp-plus.net> (2013)
- IHOBE. IHOBE. Retrieved 11 13, 2013, from <http://www.ihobe.net> (2013, 10)
- IHOBE.: Manual práctico de ecodiseño. Operativa de implantación en 7 pasos. (IHOBE, Éd.) País Vasco, España (2000)
- Johnson, K., Langdon, P. Designing a More Inclusive World. (Springer, Éd.) Cambridge, United Kingdom: Cambridge University (2001)
- Law, W. S., Antonsson, E. K. Optimization Methods for calculating design. (Citeseer, Éd.) Adv. Design Auto. **1**, 471–476 (1995)
- Lefteri, C.: Asi se hace, Técnicas de fabricación para diseño de producto. (Blume, Ed.) (2008)
- Liu, A., LU, S. C.-Y.: A new coevolution process for conceptual design. (CIRP, Éd.) CIRP Ann. Manuf. Technol. **64**(1), 153–156 (2015)
- Ljungberg, L., Edwards, K.: Design, materials selection and marketing of successful products. (Elsevier, Ed.) Mater Des. **24**(7), 519–529 (2003)
- Midžić, I., Marjanović, D.: Estimation of environmental effects in early product development. In: 5th International Congress of International Association of Societies of Design Research: Consilience and Innovation in Design. (2013)
- Ministry of housing.: Eco-indicators 99 Manual for designers. (M. o. Housing, Éd.) (2000)



31. O'Hare, J., Cope, E., Warde, S.: Five steps to eco design: improving the environmental performance of products through design. (GRANTA, Ed.) Retrieved 12 15, 2015, from Granta Design: <http://www.grantadesign.com/download/pdf/FiveStepsToEcoDesign.pdf> (2015)
32. P., M.: The principles of materials selection for engineering design. (P. Hall, Éd.) Upper Saddle River (1999)
33. Pahl, G., Weitz, W., Feldhusen, J., Grote, K.: Engineering design—a systematic approach. (Springer, Éd.) London (2007)
34. Pohl, C., Ros, M., Waldeck, B., Dinkel, F.: Imprecision and uncertainty in LCA. Dans C. Pohl, M. Ros, B. Waldeck, F. Dinkel, Springer (Éd.), Life cycle assessment (LCA)—Quo vadis? (pp. 51–68). Basel: Birkhäuser Basel (1996)
35. Pré.: SimaPro Database manual, Methods Library (éd. 2.8). (P. Consultants, Éd.) Netherlands: Consultants, Pré (2015)
36. Pugh, A.: Polyhedra: A visual approach California. (U. o. Press, Éd.) Berkeley: University of California Press (1976)
37. Qisda Corporation.: Qisda Corporation. Retrieved 10 08, 2015, from <http://www.qisda.com> (2011)
38. SAMET, W. Développement d'une méthode d'éco-innovation : Eco-MAL'IN. Doctoral Thesis, Arts et Métiers Paristech, Bordeaux (2010)
39. Sapuan, S. M. A knowledge-based system for materials selection in mechanical engineering design. (Elsevier, Éd.) Materials & Design, **22**(8), 687–695 (2001)
40. Schey, J.: Introduction to manufacturing processes. (McGraw-Hill, Éd.) New York: McGraw-Hill (2000)
41. Sébastien, P., Ledoux, Y.: Decision support systems in preliminary design. (Springer-Verlag, Éd.) Int. J. Interactive Des. Manuf. (IJ-DeM) **3**, 223–226 (2009)
42. Sousa, I., Wallace, D.: Product classification to support approximate life-cycle assessment of design concepts. (Elsevier, Éd.) Technol. Forecasting Soc. Change, **77**(3), 228–249 (2006)
43. Steadman, P.: The evolution of designs: biological analogy in architecture and the applied arts. (Routledge, Éd.) (2008)
44. Sudhir, R., Monto, M.: Design for sustainability: the role of CAD. (Elsevier, Ed.) Renew. Sustain Energy Rev. 4247–4256 (2012)
45. Swiss Centre for Life Cycle Inventories.: Swiss centre for life cycle inventories. Retrieved 11 05, 2015, from Ecoinvent: <http://www.ecoinvent.org> (2013)
46. Thompson, R.: Manufacturing processes for design professionals. Thames and Hudson (2007)
47. Tjalve, E.: A Short Course in Industrial Design. Newnes (1979)
48. Tukker, A., Haag, E., Eder, P.: Eco-design: the state of implementation in Europe—conclusions of a state of the art study for IPTS. (Elsevier, Éd.) J. Sustain. Prod. Des. **1**(3), 147–161 (2001)
49. Tukker, A., Haag, E., Eder, P., Vercalsteren, A., Van der Vlugt, M., Timmers, G.: Eco-design: European state of the art. ESTO project. Institute for Prospective Technological Studies (Joint Research Centre, European Commission), Brussels-Luxembourg (2000)
50. Ulrich, K., Eppinger, S.: Diseño y desarrollo de productos. Mc Graw Hill, New York (2013)
51. Ulrich, K., Eppinger, S.: Product design and development. Mc Graw Hill, New York (2012)
52. White, P.: Okala practitioner: integrating ecological design. (O. Team, Éd.) Phoenix (2013)
53. White, P., Belletire, S., Pierre, L. S.: Okala practitioner: Integrating Ecological Design. (Dans IDSA, Éd.) Okala (2013)
54. Zafer, B., Gero, J.: ¿Do We Need CAD during Conceptual Design?, pp. 155–164. Springer, Computer Aided Architectural Design Futures (2005)
55. Zongmin, M. Studies in fuzziness and soft computing: Fuzzy database modeling of imprecise and uncertain engineering information. (Springer, Éd.) (2006)