



Chromatic dispersion compensation by cascaded FBG with duobinary modulation scheme

Fathy M. Mustafa¹ · Sayed A. Zaky² · Ashraf A. M. Khalaf² · Moustafa H. Aly^{2,3}

Received: 24 June 2022 / Accepted: 10 September 2022 / Published online: 5 October 2022
© The Author(s) 2022

Abstract

In this paper, we propose a dispersion compensation model to minimize the chromatic dispersion to enhance system performance. The proposed model is based on applying the duobinary modulation scheme on 4-stages of cascaded identical apodized uniform fiber Bragg grating. Different apodization functions are tested to determine the one that provides the best performance. The proposed model is connected in three different connection schemes: pre, post and symmetrical, to get the best connection. To evaluate the performance of the proposed system, a comparative study is conducted using non-return to zero (NRZ) and modified duobinary (MDB) modulation schemes. For evaluation, a 10 Gbps WDM link is simulated at a distance of 100 km under a set of predefined operating parameters. Optisystem 17.0 is used for simulation and evaluation. Both quality factor (Q-factor) and bit error rate (BER) are used as performance indices. All cases of NRZ modulation scheme do not meet the minimum operational requirements in terms of Q-factor and BER. Only in the case of MDB modulation scheme, the symmetrical compensation with tanh apodization meets the minimum operational requirements with a Q-factor of 6.39 and BER of 8.44×10^{-11} . The proposed model achieves better results as compared to the other modulation schemes: a maximum Q-factor values of 8.964 and a BER of 1.3×10^{-19} with tanh apodization in the pre-compensation scheme. As compared to related work, the system performance achieves ~99% improvement.

Keywords Cascaded apodized uniform FBG · Chromatic dispersion compensation · Duobinary modulation · Modified duobinary modulation

1 Introduction

Chromatic dispersion is one of the main propagation problems, in addition to attenuation, in optical fiber communication systems. The attenuation problem has been solved by the development of optical amplifiers and especially, the erbium doped fiber amplifier (EDFA). Now, dispersion is the main issue to enhance the performance of optical fiber communication systems (Ibarra-Villalon et al. 2021). Chromatic dispersion is the pulse broadening due

✉ Moustafa H. Aly
mosaly@aast.edu

Extended author information available on the last page of the article

to the dependency of core refractive index on the propagating signal wavelength (Sonne 2021). This causes different wavelengths propagate with different velocities, which leads to group velocity delay (GVD). The broadened pulses overlap together and cause intersymbol interference (ISI) at the receiver. This leads to decrease the bit rate and the overall system performance (Dahir et al. 2020).

To overcome this, various chromatic dispersion compensation techniques have been developed. One of the most efficient techniques is the use of (FBG) (Mustafa et al. 2021).

In optical fiber communication systems, FBG is used to compensate chromatic dispersion at the transmitter side. FBG contains a number of small planes, gratings, with different refractive indices inside its core (Sahota et al. 2020). Based on planes distribution, FBG has two types: uniform FBG (UFBG) and chirped FBG (CFBG) (Sayed et al. 2020a, b). Many apodization functions are developed to enhance FBG performance. The main idea behind using FBG as a dispersion compensator is narrowing the full width at half maximum (FWHM) with an acceptable level of reflectivity (Dar and Jha 2017). To minimize FWHM, a chain of n -stages cascaded FBG is used. FBG has also many other applications in different fields, like irradiated polymers (Hamdalla and Nafee 2015) and in wavelength shift compensation under sea water (Mahran et al. 2009).

In this work, we use apodized uniform FBG (AUFBG) (Toba et al. 2019). In addition, the using of suitable and efficient modulation scheme leads to increasing the tolerance of chromatic dispersion, the spectral efficiency and the transmission distance. Therefore, advanced modulation schemes such as DB modulation and MDB modulation have been used. These advanced modulation schemes have many advantages. They have a narrow spectral width, high anti-nonlinear ability, better dispersion tolerance, good transmission performance and a simple and cost-effective configuration (Mishra et al. 2020).

The aim of this work is to enhance the performance of chromatic dispersion compensation in a standard single mode optical fiber. To achieve this, we propose a model of four-stages cascaded identical apodized UFBGs with DB modulation format. The model is evaluated in terms of Q-factor and BER. In the beginning, the most common apodization functions are investigated to determine the best function. Then, we examine different FBG connection schemes (i.e., pre, post and symmetrical schemes). Finally, DB modulation format is compared with MDB and NRZ modulation formats. Optisystem 17.0 is used to simulate and evaluate 10 Gbps single channel optical fiber communication system.

The remainder of this paper is organized as follows. Section 2 illustrates the basic model and analysis. The proposed model is explained in Sect. 3. Section 4 displays and discusses the simulation results. Section 5 is devoted to the main conclusions.

2 Basic model and analysis

In this section, the basic model and analysis are discussed. We start with discussing the modulation schemes. Then, the use of AUFBG in dispersion compensation is described.

2.1 Modulation schemes

2.1.1 NRZ modulation scheme

The NRZ modulation scheme is the simplest and most common modulation scheme (Gutiérrez-Castrejón et al. 2021). This is illustrated in Fig. 1.

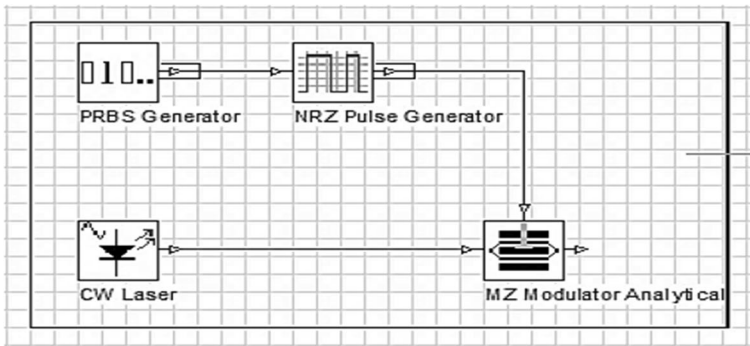

Fig. 1 NRZ transmitter

In NRZ, the pulse is ON for the entire bit period. The NRZ is used because it is perceptible to laser phase noise, and it needs a moderately low electrical bandwidth for transmitter and receivers. The NRZ pulses have a narrow optical spectrum which improves the dispersion tolerance but it has the effect of ISI. However, it is not suitable in high bit rate long haul systems (Seraji and Kiaee 2017).

2.1.2 DB and MDB modulation schemes

The DB modulation scheme is an effective scheme which can increase the spectral efficiency (Kaur and Dewra 2014). In view of spectral efficiency and chromatic dispersion tolerance, DB modulation scheme outperforms the NRZ scheme. Due to the increased bandwidth requirement for high bit rates long haul optical fiber communication systems, DB scheme became a significant modulation scheme (Krishna and Tiwari 2015). The fundamental idea of DB modulation is adding a data sequence to a 1-bit delayed version of itself. The transmitted signal of DB modulation is given by Šalík et al. (2015).

$$x(t) = \sum_{k=-\infty}^{\infty} d_k q(t - kT), d_k = 0, 1 \quad (1)$$

where d_k is the data bits, $q(t)$ is the transmitted pulse and T is the bit period.

Figure 2 shows the DB transmitter (Kaur and Dewra 2014).

For duobinary pulses, direct detection PIN photodetector is used. It is simple and hence the Mach–Zehnder modulator (MZM) for direct detection should be biased at nullpoint. The MDB modulation provides a compressed bandwidth (Kaur and Dewra 2014). Generation of MDB pulses is carried out by adding an extra delay as shown in Fig. 3.

2.2 Apodized uniform FBG (AUFBG)

FBGs have emerged as an important element, mostly in optical fiber communications, especially in long haul networks.

The reflectivity of FBG has sidelobes, which can be minimized by applying different index profiles, called as apodization. The refractive index modulation along the fiber axis can be represented by Šalík et al. (2015)

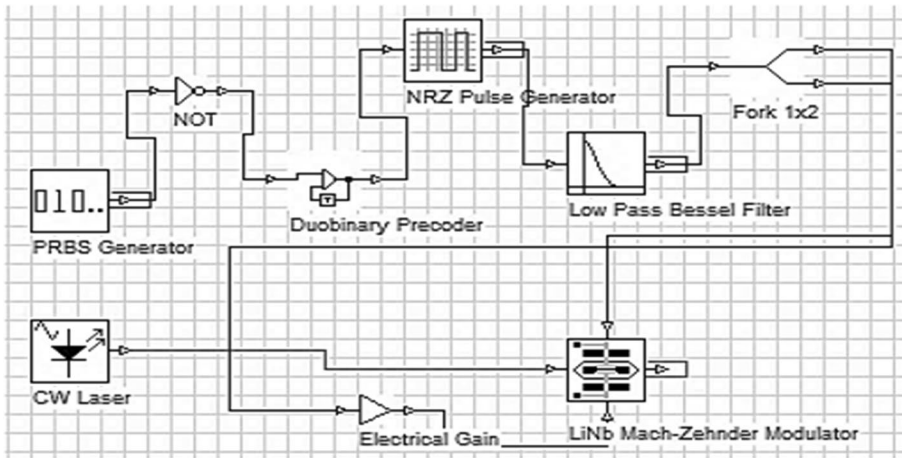

Fig. 2 Duobinary transmitter (Kaur and Dewra 2014)

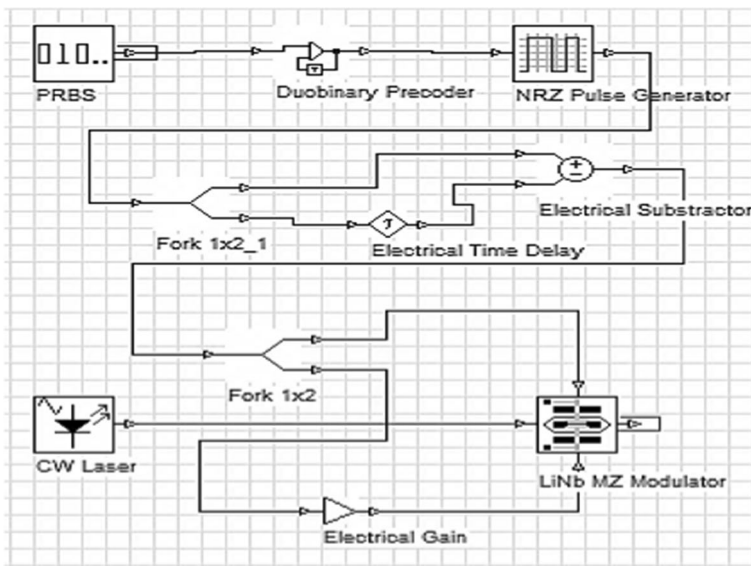

Fig. 3 MDB transmitter (Kaur and Dewra 2014)

$$n(z) = n_{co} + \Delta n_o \cdot A(z) \cdot n_d(z) \tag{2}$$

where n_{co} is the core refractive index, Δn_o is the maximum index variation, $A(z)$ is the apodization function, $n_d(z)$ is the index variation function.

There are many apodization functions which depend on the grating length, L . In this work, we focus on the most useful functions illustrated in Table 1 (Šalík et al. 2015).

Table 1 Apodization functions in the proposed model (Šalík et al. 2015)

Type	Apodization function
Gaussian	$A(z) = \exp(-ln2 \left(\frac{2(z-\frac{L}{2})}{0.5L} \right)^2)$
Hamming	$A(z) = 0.54 - 0.4\cos(2\pi z/L)$
Tanh	$A(z) = \tanh(4z/L)\tanh(4(z-1)/L)$
Raised Sine	$A(z) = (\sin(z/L))^2$
Sinc	$A(z) = \text{sinc}(2\pi(z-L/2)/L)$
Raised cosine	$A(z) = (\cos(2z/L-1))^8$

where $0 \ll z \ll L$

2.3 AUFBG dispersion compensation

The main idea of chromatic dispersion compensation by FBG in optical fiber communication system is inserting a wavelength-dependent time delay (Sayed et al. 2021). The time delay, $\tau(\lambda)$ for each wavelength along the AUFBG can be obtained by Mustafa et al. (2021)

$$\tau(\lambda) = (\lambda_B - \lambda) \frac{2n_{eff}}{\Delta\lambda c} L \tag{3}$$

where c is the speed of light in free space and $\Delta\lambda$ is difference in wavelength between wavelengths corresponding to maximum and minimum value of induced refractive index along the fiber grating, and could be obtained by Mustafa et al. (2021)

$$\Delta\lambda = 2\Lambda(n_{max} - n_{min}) \tag{4}$$

3 Proposed model

We propose a model to achieve the aim of this study which is the chromatic dispersion compensation in single mode optical fiber. The proposed model is based on applying DB modulation scheme on 4-stages of cascaded identical AUFBGs. Each stage of the proposed model is connected to a standard optical circulator. Figure 4 illustrates the connections and operation of the cascaded AUFBGs.

The input signal enters the first stage and the reflected signal is connected to the input of the second stage, and so on. The reflected signal of the last stage is considered as the output of the cascaded AUFBGs. The cascaded module is connected in a 10 Gbps WDM link. Through a comparative study, we evaluate the performance of the proposed model in terms of Q-factor and BER. Figure 5 shows the procedure of this comparison. It includes three cases based on which modulation scheme we use, NRZ, DB or MDB. In each case, different connection schemes (i.e. pre, post or symmetrical) are applied. Under each connection scheme, we apply, in one-by-one manner, all the apodization functions shown in Table 1.

The best configuration is the one having the highest Q-factor and the lowest BER. The proposed model is simulated and evaluated by Optisystem 17.0.

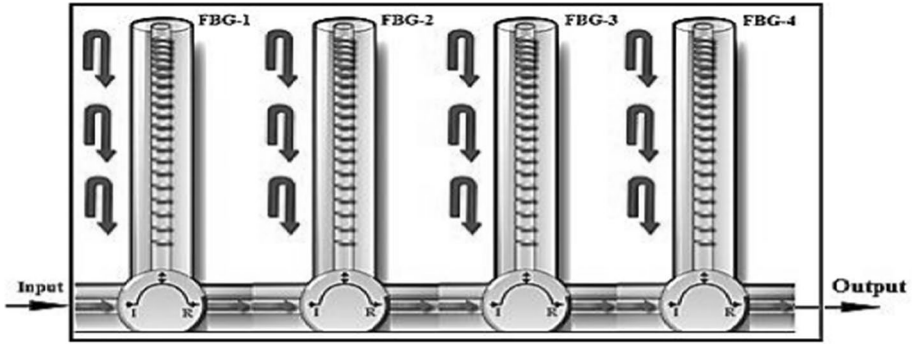

Fig. 4 Connections and operation of the cascaded AUFBG

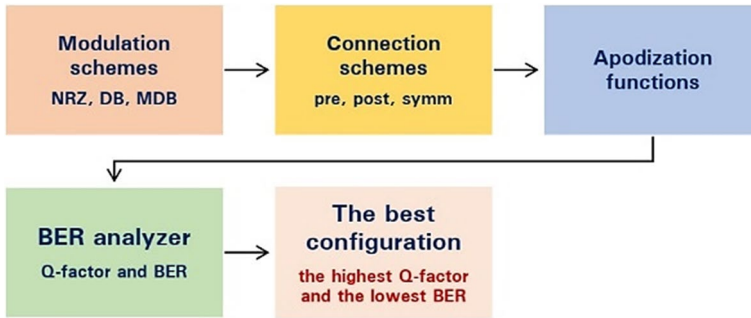

Fig. 5 Procedure of the comparison study

4 Results and discussion

This section addresses and discusses the results of the comparative study. Table 2 includes the simulation parameters of this study for the FBG, standard single mode fiber (SSMF) and the link. The proposed configuration to be acceptable must meet the minimum operational requirements in terms of Q-factor (> 6) and BER ($< 10^{-9}$) (Palacharla et al. 1995). The configuration with unreasonable results is rejected.

4.1 Case one: NRZ modulation scheme

Figure 6 illustrates the structure of the proposed model in different compensation schemes with NRZ modulation scheme.

The obtained results of NRZ in different compensation schemes do not meet the operational requirements. In most sub-cases, the output signal is totally lost where Q-factor=0 and BER=1. Only the sub-cases illustrated in Table 3 provide an output signal but it can't be distinguished.

Table 2 Simulation parameters (Sayed et al. 2020a, b)

AUFBG	
Grating length (mm)	5
Wavelength (nm)	1553.6
Effective refractive index	1.45
Induced refractive index	10^{-4}
SSMF	
Reference wavelength (nm)	1553.6
Length (km)	100
Attenuation (dB/km)	0.2
Dispersion (ps/nm km)	17
WDM link	
Input power (dBm)	0
Bit rate (Gbps)	10
EDFA gain (dB)	40
EDFA noise figure(dB)	4
PIN photodetector responsivity (A/W)	1
PIN photodetector dark current (nA)	30
Bessel filter cutoff frequency	$0.75 \times \text{bit rate}$

4.2 Case two: DB modulation scheme

4.2.1 Pre-compensation

The basic structure of the pre-compensation scheme in case two is displayed in Fig. 7.

Table 4 shows the obtained results of the pre-compensation scheme in case two, all apodization functions, except Gaussian function, exceed the minimum operational requirements.

The tanh apodization function achieves the maximum acceptable results, $Q=8.964$ and $BER=1.316 \times 10^{-19}$. The other apodization functions results are rejected, where the obtained values of BER are unreasonable.

4.2.2 Post-compensation scheme

Figure 8 illustrates the basic structure of the post-compensation scheme in case two.

The obtained results shown in Table 5 reveal that all apodization functions are unreasonable.

4.2.3 Symmetrical compensation scheme

The symmetrical compensation scheme of case two is illustrated in Fig. 9.

In case of Gaussian apodization function, the output signal is totally lost. The other apodization functions lead to unreasonable values of BER. Table 6 summarizes the simulation results of symmetrical compensation scheme of case two.

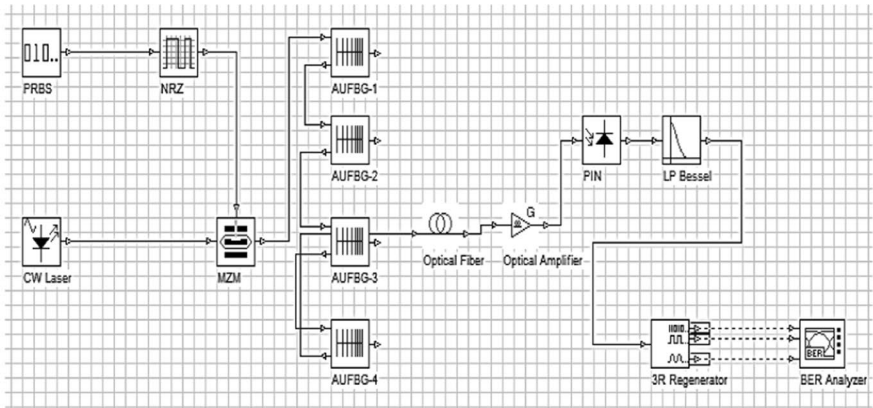

(a)

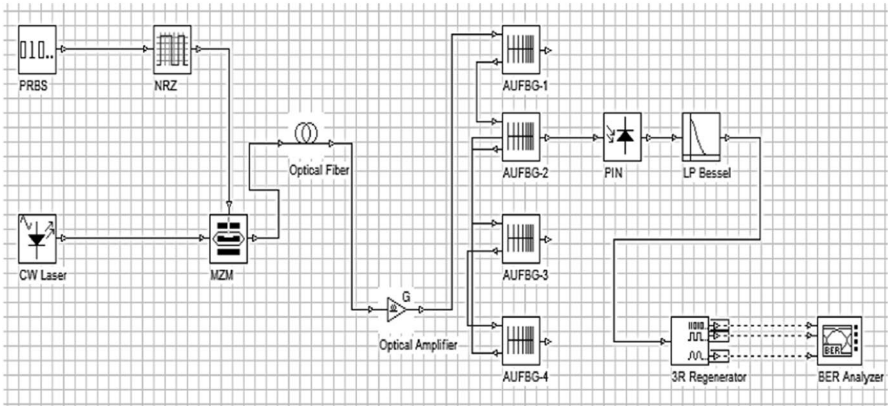

(b)

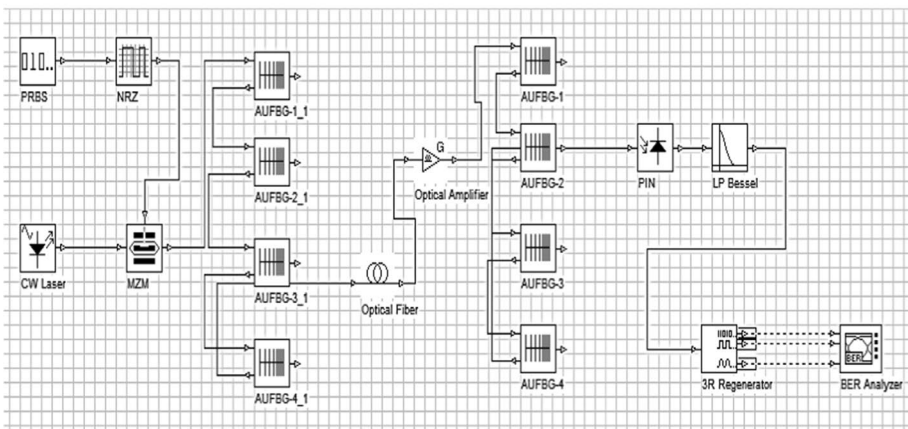

(c)

Fig. 6 **a** Pre-compensation scheme of case one. **b** Post-compensation scheme of case one. **c** Symmetrical compensation scheme of case one

Table 3 Results for case one

Connection scheme	Apodization function	Q-factor	BER
Pre	Tanh	3.232	5.403×10^{-4}
Symmetrical	Tanh	3.751	8.315×10^{-5}

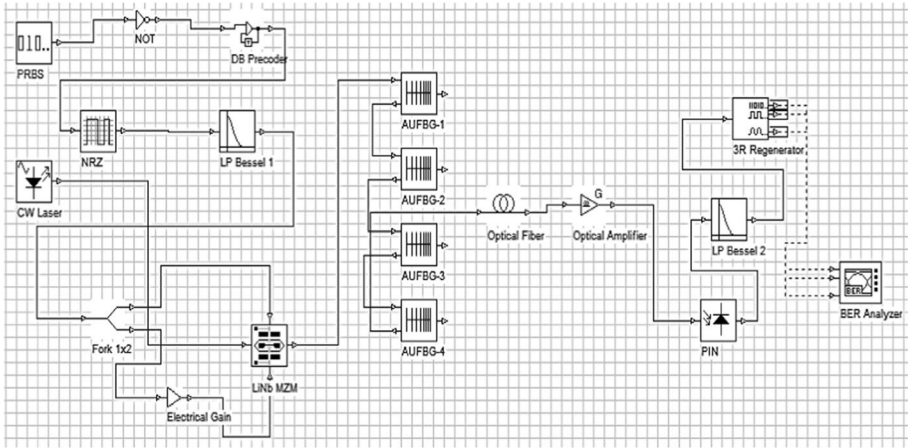

Fig. 7 Pre-compensation scheme of case two

Table 4 Results of pre-compensation scheme in case two

Connection scheme	Apodization function	Q-factor	BER
	Tanh	8.964	1.316×10^{-19}
	Hamming	10.054	3.594×10^{-24}
	Raised Cosine	10.242	2.61×10^{-25}
	Raised Sine	10.275	3.830×10^{-24}
	Sinc	10.152	1.333×10^{-24}

4.3 Case three: MDB modulation scheme

4.3.1 Pre-compensation scheme

Figure 10 illustrates the pre-compensation scheme of case three.

In this case, none of the apodization functions meet the minimum operational requirements. Table 7 shows that the output signal is indistinguishable in all apodization functions except in Gaussian, where it is totally lost.

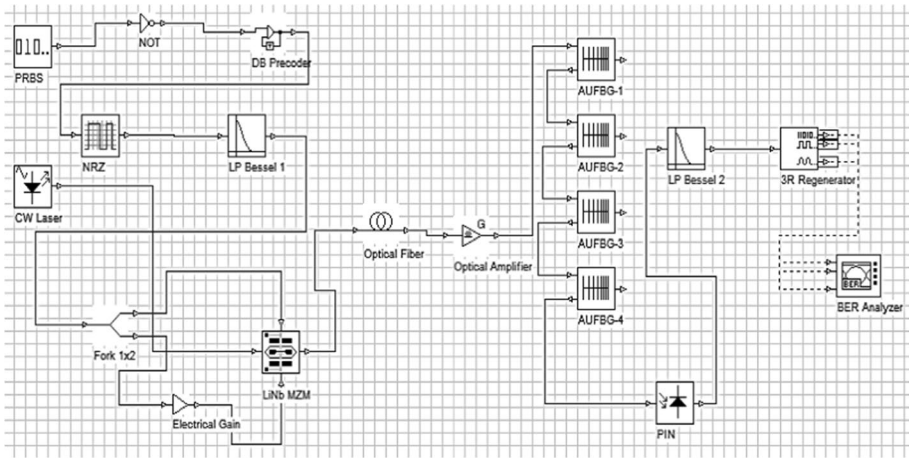

Fig. 8 Post-compensation scheme of case two

Table 5 Results of post-compensation scheme in case two

Connection scheme	Apodization function	Q-factor	BER
Post	Gaussian	13.963	1.018×10^{-44}
	Tanh	14.412	1.605×10^{-47}
	Hamming	10.292	3.139×10^{-25}
	Raised Cosine	10.242	5.429×10^{-25}
	Raised Sine	10.227	6.298×10^{-25}
	Sinc	10.17	1.124×10^{-24}

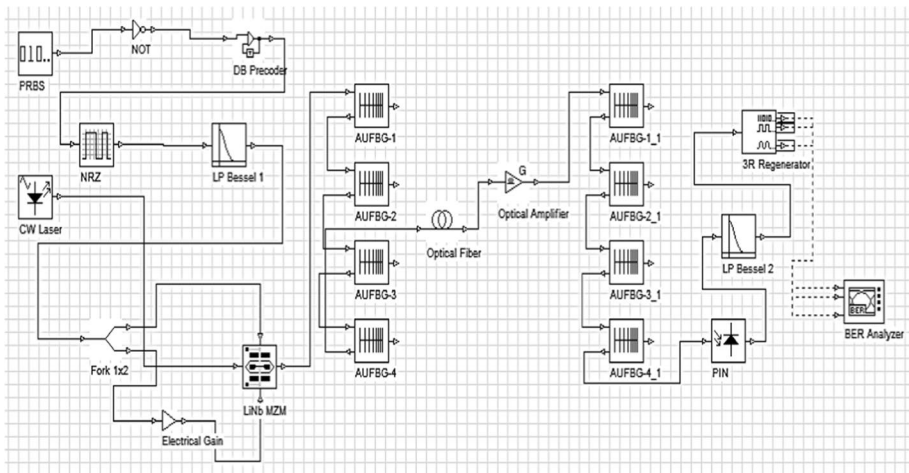

Fig. 9 Symmetrical compensation scheme of case two

Table 6 Results of symmetrical compensation scheme of case two

Connection scheme	Apodization function	Q-factor	BER
	Tanh	12.069	6.238×10^{-34}
	Hamming	10.247	4.961×10^{-25}
	Raised Cosine	10.228	6.211×10^{-25}
	Raised Sine	10.117	1.894×10^{-24}
	Sinc	10.288	3.274×10^{-25}

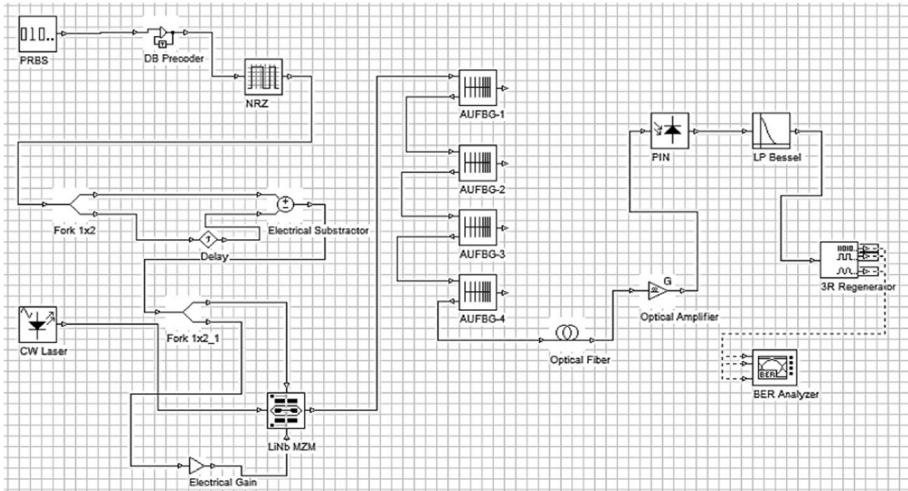

Fig. 10 Pre-compensation scheme of case three

Table 7 Results of pre-compensation scheme in case three

Connection scheme	Apodization function	Q-factor	BER
	Tanh	4.159	1.497×10^{-5}
	Hamming	2.675	0.00351786
	Raised Cosine	2.696	0.00329704
	Raised Sine	2.688	0.00335409
	Sinc	2.664	0.00357479

4.3.2 Post-compensation scheme

The basic structure of the post-compensation scheme of case three is displayed in Fig. 11.

Table 8 summarizes the results of post-compensation scheme of case three. None of the apodization functions meet the minimum operational requirements.

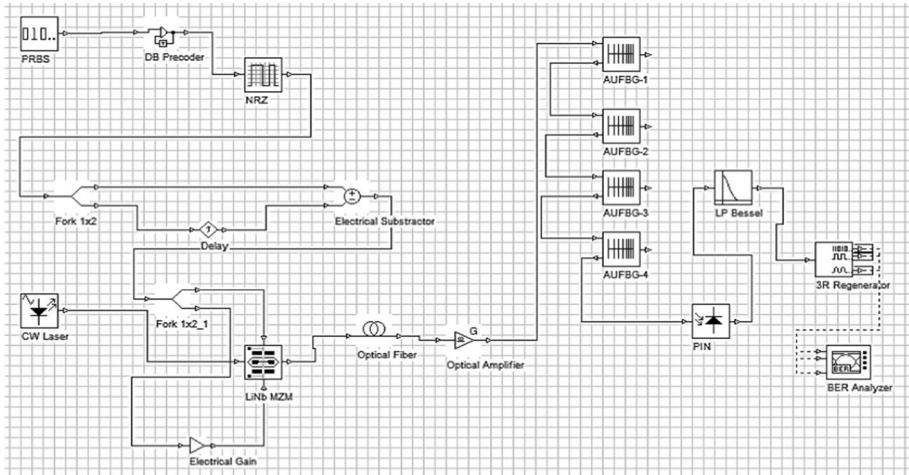

Fig. 11 Post-compensation scheme of case three

Table 8 Results of post-compensation scheme of case three

Connection scheme	Apodization function	Q-factor	BER
Post	Gaussian	4.553	2.377×10^{-6}
	Tanh	4.015	2.699×10^{-5}
	Hamming	2.706	0.003192
	Raised Cosine	2.72	0.003063
	Raised Sine	2.701	0.003259
	Sinc	2.694	0.003312

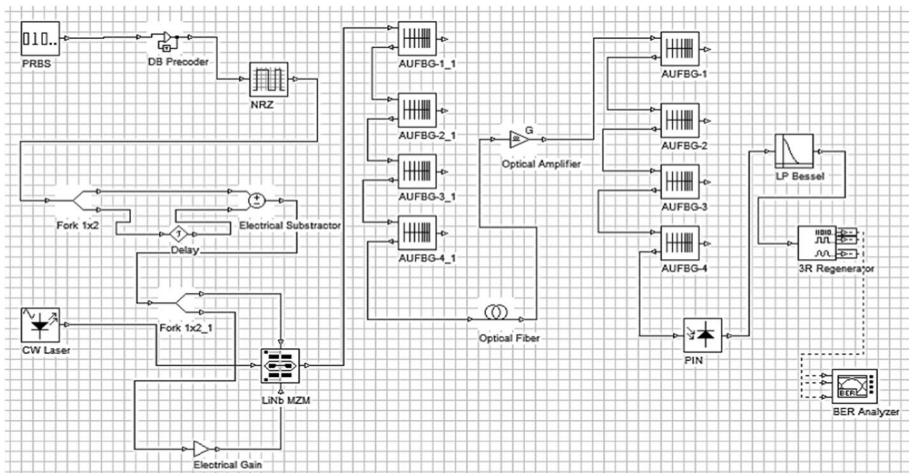

Fig. 12 Symmetrical compensation scheme of case three

Table 9 Results of symmetrical compensation scheme of case three

Connection scheme	Apodization function	Q-factor	BER
	Tanh	6.386	8.44×10^{-11}
	Hamming	2.681	0.00339
	Raised Cosine	2.675	0.00351
	Raised Sine	2.73	0.00303
	Sinc	2.679	0.00343

4.3.3 Symmetrical compensation scheme

The symmetrical compensation scheme of case three is displayed in Fig. 12.

As shown in Table 9, only the tanh apodization function exceeds the minimum operational requirements. The output signal is totally lost in case of Gaussian apodization and is indistinguishable in the other functions. The tanh apodization function has the best results with a Q-factor of 6.39 and BER of 8.44×10^{-11} .

4.4 Summarized results

As mentioned above, all cases in NRZ modulation do not meet the operational requirements and the output signal is totally lost. Also, in MDB modulation the results do not meet the operational requirements but the output signal is not totally lost. We note that

Fig. 13 Q-factor for all sub-cases which meet the minimal operational requirements

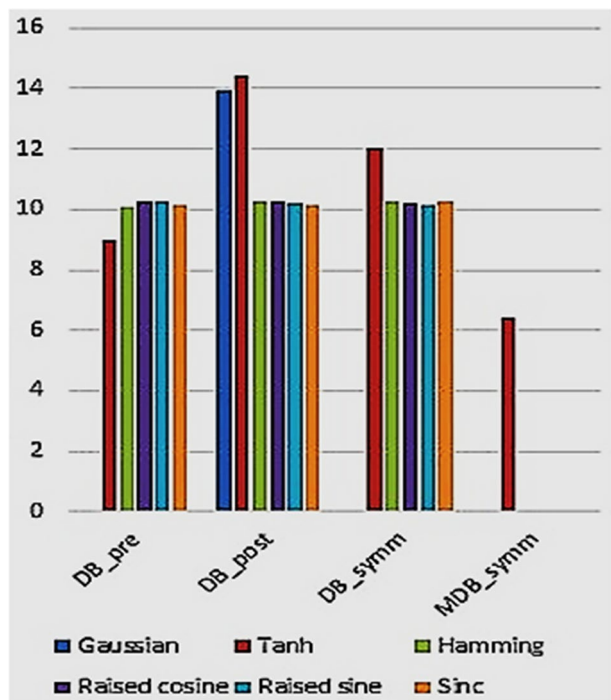

Table 10 BER of sub-cases that meet the minimal operational requirements

Apodization function	DB			MDB
	Pre	Post	Symm.	Symm.
Gaussian	–	1.0×10^{-44}	–	–
Tanh	1.3×10^{-19}	1.6×10^{-47}	6.2×10^{-34}	8.4×10^{-11}
Hamming	3.5×10^{-24}	3.1×10^{-25}	4.9×10^{-25}	–
Raised Cosine	2.6×10^{-25}	5.4×10^{-25}	6.2×10^{-25}	–
Raised Sine	3.8×10^{-24}	6.2×10^{-25}	1.8×10^{-24}	–
Sinc	1.3×10^{-24}	1.1×10^{-24}	3.2×10^{-25}	–

all connection schemes in DB modulation meet the operational requirements. It provides the maximum reasonable results in pre connection scheme with tanh apodization function, where Q-factor = 8.964 and BER = 1.3×10^{-19} . Figure 13 summarizes the obtained results, Q-factor, for all sub-cases which meet the minimal operational requirements.

The BER, of the sub-cases that meet the minimal operational requirements is illustrated in Table 10.

From Table 10, it is clear that the tanh apodization function achieves the best reasonable results in terms of Q-factor and BER in the pre-compensation scheme under DB. Also, it is the only apodization function that meets the minimum operational criteria in symmetrical-compensation under MDB.

4.5 Related studies results

To declare the performance optimization of the proposed model, this section illustrates the previous studies results, see Table 11.

5 Conclusion

In this paper, we proposed a 4-stages cascaded identical AUFBG model to minimize the chromatic dispersion and to enhance system performance. The proposed model is evaluated by Optisystem 17.0 in terms of Q-factor and BER. A 10 Gbps WDM link is simulated at distance of 100 km. A comparative study is performed based on connection schemes, apodization functions and modulation schemes. Three different modulation schemes, NRZ, DB and MDB are used. It is found that DB modulation scheme with tanh apodization in pre-compensation scheme provides the best acceptable results: a Q-factor of 8.964 and a BER of 1.3×10^{-19} . We do not recommend using the proposed model in the sub-cases with unreasonable results; shaded cells in Table 10. The percentage of improvement in the system performance over the related works is about 99%.

Table 11 Previous studies results

Ref. year	Model of comparison	Modulation format	Bit rate (Gbps)	Q-factor	BER	% superiority of present model over the mentioned reference
Šalík et al. (2015)	An FBG system consists of four stages cascaded uniform FBGs at a distance of 30 km	NRZ	10	6.135	4.24×10^{-10}	99
Gutiérrez-Castrejón et al. (2021)	Performance of a long-haul optical fiber transmission at 800 km. It based on DCF and SSMF	DB, PSBT and NRZ	40	NA	1×10^{-10}	99
Kaur and Dewra (2014)	Four identical stages cascaded uniform FBGs	NRZ	10	7.94	1.96×10^{-14}	99
Hussein et al. (2019)	A hybrid system of dispersion compensating fiber (DCF) and a tanh apodized chirped FBG	NRZ	10	7.106	5.47×10^{-13}	99
Proposed model (present work) Case 2	Tanh apodization in pre-compensation scheme	DB	10	8.964	1.3×10^{-19}	

Authors' contributions F.M.M., S.A.Z., A.A.K., A.H.B. and M.H.A. have directly participated in the planning, execution, and analysis of this study. AHB drafted the manuscript. All authors have read and approved the final version of the manuscript.

Funding Open access funding provided by The Science, Technology & Innovation Funding Authority (STDF) in cooperation with The Egyptian Knowledge Bank (EKB). The authors did not receive any funds to support this research.

Data availability The data used and/or analyzed during the current study are available from the corresponding author on reasonable request.

Declarations

Competing interests The authors declare that they have no competing interests.

Ethical approval Not Applicable.

Open Access This article is licensed under a Creative Commons Attribution 4.0 International License, which permits use, sharing, adaptation, distribution and reproduction in any medium or format, as long as you give appropriate credit to the original author(s) and the source, provide a link to the Creative Commons licence, and indicate if changes were made. The images or other third party material in this article are included in the article's Creative Commons licence, unless indicated otherwise in a credit line to the material. If material is not included in the article's Creative Commons licence and your intended use is not permitted by statutory regulation or exceeds the permitted use, you will need to obtain permission directly from the copyright holder. To view a copy of this licence, visit <http://creativecommons.org/licenses/by/4.0/>.

References

- Dahir, A.A., Yu, Z.: Dispersion compensation by using FBG and low pass Gaussian filter. In: 2020 IEEE 5th International Conference on Computer and Communication Systems (ICCCS), Shanghai, China, pp. 803–806, 15–18 May (2020)
- Dar, A.B., Jha, R.K.: Chromatic dispersion compensation techniques and characterization of fiber Bragg grating for dispersion compensation. *Opt. Quant. Electron.* **49**(108), 1–35 (2017)
- Gutiérrez-Castrejón, R., Fernández-Segura, O., Torres-Ferrera, P., Ceballos-Herrera, D.E.: Performance analysis of a directly modulated semiconductor optical amplifiers using non-return-to-zero, duobinary and quaternary pulse amplitude modulation signaling. *IET Optoelectron.* **15**(1), 8–19 (2021)
- Hamdalla, T.A., Nafee, S.S.: Bragg wavelength shift for irradiated polymer fiber Bragg grating. *Opt. Laser Technol.* **74**, 167–172 (2015)
- Hussein, T.F., Rizk, M.R., Aly, M.H.: A Hybrid DCF/FBG Scheme for Dispersion Compensation over a 300 km SMF. *Opt. Quant. Electron.* **51**(4), 103 (2019)
- Ibarra-Villalon, H.E., Pottiez, O., Gómez-Vieyra, A., Lauterio-Cruz, J.P., Bracamontes-Rodríguez, Y.E.: Numerical study of the fiber dispersion contribution in the pulse propagation problem. *Eur. J. Phys.* **42**(2), Article 025303 (2021)
- Kaur, R., Dewra, S.: Duobinary modulation format for optical system—a review. *Int. J. Adv. Res. Electr. Electron. Instrum. Eng.* **3**(8), 11039–11046 (2014)
- Krishna, V.R., Tiwari, V.: Comparison of duobinary and modified duobinary modulation schemes for optimized transmission at 40 Gbps. In: 2015 IEEE 12th International Conference on Wireless and Optical Communications Networks (WOCN), Bangalore, India, pp. 1–4, 11 September (2015)
- Mahran, O., Hamdallah, T.A., Aly, M.H., El-Samahy: Apodized chirped fiber Bragg gratings for wavelength shift compensation under sea level. *J. Appl. Sci. Res.* **5**(10), 1592–1603 (2009)
- Mishra, P., Panda, T., Rout, S.S., Palai, G.: Investigation of a 16 channel 40 Gbps varied GVD DWDM system using dispersion compensating fiber. In: 2020 IEEE 5th International Conference on Computer Science, Engineering and Applications (ICCSEA), Shanghai, China, pp. 1–5, 15–18 May (2020)
- Mustafa, F.M., Zaky, S.A., Khalaf, A.A., Aly, M.H.: Dispersion compensation in silica doped fiber using soliton transmission technique over cascaded FBG. *Opt. Quant. Electron.* **53**(5), 1–17 (2021)

- Palacharla, P., Barnard, C.W., Myslinski, P., Chrostowski, J., Neumann, R., Khalil, R.: Bit error rate analysis of optical data links for computer communications. In: Palacharla, P., Barnard, C.W., Myslinski, P., Chrostowski, J., Neumann, R., Khalil, R. (eds) *Applications of Photonic Technology*, pp. 109–113. Springer, Boston, MA (1995)
- Sahota, J.K., Gupta, N., Dhawan, D.: Fiber Bragg grating sensors for monitoring of physical parameters: a comprehensive review. *Opt. Eng.* **59**(6), Article 060901 (2020)
- Šalík, P., Čertík, F., Roka, R.: Duobinary modulation format in optical communication systems. *Adv. Signal Process.* **3**(1), 1–7 (2015)
- Sayed, A.F., Mustafa, F.M., Khalaf, A.A., Aly, M.H.: Apodized chirped fiber Bragg grating for post dispersion compensation in wavelength division multiplexing optical networks. *Int. J. Commun. Syst.* **33**(14), 1–12 (2020a)
- Sayed, A.F., Mustafa, F.M., Khalaf, A.A., Aly, M.H.: An enhanced WDM optical communication system using a cascaded fiber Bragg grating. *Opt. Quant. Electron.* **52**(3), 1–21 (2020b)
- Sayed, A.F., Mustafa, F.M., Khalaf, A.A., Aly, M.H.: Spectral width reduction using apodized cascaded fiber Bragg grating for post-dispersion compensation in WDM optical networks. *Photon Netw. Commun.* **41**(3), 231–241 (2021)
- Seraji, F.E., Kiaee, M.S.: Eye-diagram-based evaluation of RZ and NRZ modulation methods in a 10-Gb/s single-channel and a 160-Gb/s WDM optical networks. *Int. J. Opt. Appl.* **7**(2), 31–36 (2017)
- Sonne, A.: Designing and controlling a single-mode dual concentric core fiber with nearly zero ultra-flattened chromatic dispersion for linear or nonlinear application. *Optik* **231**, Article 166375 (2021)
- Toba, M., Mustafa, F.M.: *IntechOpen*, pp. 328–355 (2019). <https://doi.org/10.5772/intechopen.78479>

Publisher's Note Springer Nature remains neutral with regard to jurisdictional claims in published maps and institutional affiliations.

Authors and Affiliations

Fathy M. Mustafa¹ · Sayed A. Zaky² · Ashraf A. M. Khalaf² · Moustafa H. Aly^{2,3} 

Fathy M. Mustafa
fmmg80@eng.bsu.edu.eg

Sayed A. Zaky
sa134@fayoum.edu.eg

Ashraf A. M. Khalaf
ashkhalaf@yahoo.com

¹ Electrical Engineering Department, Faculty of Engineering, Beni-Suef University, Beni-Suef, Egypt

² Electronics and Communications Engineering Department, Faculty of Engineering, Minia University, Minia, Egypt

³ Electronics and Communication Engineering Department, College of Engineering and Technology, Arab Academy for Science, Technology and Maritime Transport, P.O.B. 1029, Abou Kir, Alexandria, Egypt