



Anaphora and agreement in the Turkish DP

Delimiting binding-through-Agree

Lefteris Paparounas¹ · Faruk Akkuş²

Received: 31 December 2021 / Accepted: 12 April 2023
© The Author(s) 2023

Abstract

Whether the operation Agree should be taken to underlie anaphoric binding has been the topic of much recent debate. In this paper, we provide a novel empirical argument in favor of the role of ϕ -features and Agree in binding. The argument revolves around the intimate relationship between agreement and anaphora in the Turkish nominal domain, where certain complex pronominals can agree only if they locally bind an anaphor or bound pronoun. We argue that these facts can be readily understood if ϕ -features are crucially implicated in the syntactic derivation of binding. At the same time, we argue that not all binding can be reduced to Agree, based on data from Turkish PPs.

Keywords Binding · Agreement · Agree · Anaphora · Minimal pronouns · Turkish

1 Introduction

An ongoing debate within generative grammar concerns the status of Condition A of the Binding Theory (Chomsky 1981).

One prominent view holds that the effects of Condition A can be reduced to the operation Agree (Hornstein 2001, 2007; Reuland 2001, 2006, 2011; Kayne 2002; Zwart 2002; Quicoli 2008; Heinat 2009; Hicks 2009; Kratzer 2009; Antonenko 2011, 2018; Bader 2011; Drummond et al. 2011; Rooryck and vanden Wyngaerd 2011; Wurmbrand 2017; Messick and Raghotham 2022; Murphy and Meyase 2022). The proposals in this body of work share the intuition that Agree is involved in the derivation of

✉ L. Paparounas
lefteris@sas.upenn.edu

✉ F. Akkuş
fakkus@umass.edu

¹ Department of Linguistics, University of Pennsylvania, 3401-C Walnut Street, Suite 300, Philadelphia, PA 19104-6228, USA

² Department of Linguistics, University of Massachusetts Amherst, Integrative Learning Center, 650 North Pleasant Street, Amherst, MA 01003, USA

anaphoric relations, and sometimes diverge in terms of the nature of the features involved: some accounts treat binding as transmission of ϕ -features (e.g. Kayne 2002; Reuland 2006; Kratzer 2009), while others posit Agree for dedicated features related to anaphors (Hicks 2009).

A different line of work opposes the reduction of anaphoric binding to Agree (Safir 2014; Charnavel and Sportiche 2016; Charnavel 2019; Preminger 2019; Rudnev 2020; Bruening 2021). Once again, these proposals do not necessarily form a homogeneous whole, sometimes maintaining different views of what Condition A effects should be attributed to.

Defenses of binding-as-Agree often begin from a largely conceptual standpoint. This conceptual orientation arises largely from two important considerations. Firstly, Minimalist thinking admits no syntactic operation beyond Merge and Agree (Chomsky 2000, 2001). In work where strict adherence to Minimalist tenets is judged necessary, reducing Condition A to one of the two fundamental syntactic operations thus becomes a theory-internal imperative, at least for some authors (see e.g. Hicks 2009: 6–8; Rooryck and vanden Wyngaerd 2011: 1). Secondly, as has been repeatedly pointed out (most recently in Preminger 2019), the mechanics of (standard) Agree do not straightforwardly align with the particulars of anaphoric binding. For example, one popular formulation of Agree involves transmission of features upwards from a valued XP goal to an unvalued head probe (Chomsky 2000). Against this background, anaphoric binding seems recalcitrant in a few ways. In binding, ϕ -features seem to be passed downwards, from the antecedent to the anaphor; moreover, binding ostensibly involves a dependency between two DPs, as opposed to a head and a DP.

Agree-based accounts of binding thus face a serious technical challenge. Much work acknowledges a theoretical pressure to reduce binding to the primitive operation Agree; but the apparent mismatch between Agree configurations and binding configurations makes this reduction less than straightforward. It is thus not uncommon for theories of Agree-mediated binding to assert that, for theory-internal reasons, Agree *must* be involved, before proceeding to detail *how* anaphoric binding can be made to fit the profile of agreement dependencies. A wide variety of different implementations has been proposed, perhaps reflecting the difficulty of fully identifying binding with Agree.

Importantly, the prevalence of these conceptual concerns has led to interesting empirical questions being left relatively unaddressed. One of these questions, stated immediately below, forms the point of departure for this paper.

(1) Does binding ever show the *morphological* reflexes of ϕ -agreement?

With respect to (1), two empirical observations are often adduced in support of binding through Agree for ϕ -features (e.g. Kratzer 2009: 195–197). Firstly, anaphors tend to match the ϕ -features of their antecedents; secondly, anaphors often fail to control co-varying agreement (the *Anaphor Agreement Effect*; Rizzi 1990); see Sect. 4.1 for more discussion.

But Agree-based accounts may make even more specific predictions regarding the interplay between anaphora and agreement. In particular, if binding establishes Agree dependencies beyond those needed for the purposes of agreement, we might wonder if binding ever repairs agreement configurations that would otherwise fail. This way of thinking leads to a more specific instantiation of (1), namely (2):

- (2) Does binding ever license agreement possibilities that would otherwise be illicit?

Against the background of (2), this paper has two goals.

The paper's first goal, and its main focus, is to present a case study on (2). We will argue that an intricate agreement pattern in the Turkish nominal domain instantiates one case where the answer to (2) is affirmative, thus providing striking support for Agree-based accounts of binding that involve transmission of ϕ -features.

The basic pattern is as follows. In one variety of Turkish (see Sect. 2.2.1 and footnote 5), certain complex pronominals, including adnominal pronouns such as *biz Türkler* 'we Turks,' behave like simplex pronouns in the verbal domain, triggering co-varying agreement (3). However, in the nominal domain, the relevant complex pronominals behave unlike simplex pronouns: they are opaque for nominal agreement when marked with genitive Case (4). We will refer to said complex pronominals as *Default Triggering Nominals* (DTNs), owing to their capacity to trigger default agreement in sentences like (4); and, for reasons that will become clear below, we will refer to the effect at play in (4) as *Relativized Case Opacity*.¹

- (3) Biz Türk-ler oraya git-ti- { **k** / * \emptyset }
 we Turk-PL there go-PST- 1PL 3SG
 'We Turks went there.'
- (4) Kemal [biz Türk-ler-in oraya git-tiğ- { ***imiz** / **in** }
 Kemal we Turk-PL-GEN there go-NMLZ- 1PL.POSS 3SG.POSS
]-i san-dı- \emptyset .
 -ACC think-PST-3SG
 'Kemal thought that we Turks went there.'

The main empirical focus of our paper comes from the observation that Relativized Case Opacity is overridden under local binding: if a normally non-agreeing genitive-marked complex pronominal locally binds an anaphor or a bound pronoun, it can agree, as in (5). Descriptively speaking, then, local binding licenses an otherwise impossible agreement possibility.

- (5) Kemal [biz Türk-ler-in **birbir-imiz-i** sev-diğ- {
 Kemal we Turk-PL-GEN each.other-1PL.POSS-ACC like-NMLZ-
imiz / **in** }]-i söyle-di- \emptyset .
 1PL.POSS 3SG.POSS -ACC say-PST-3SG
 'Kemal said that we Turks like each other.'

Our first goal is to argue that this striking case of agreement enabled by binding can be readily understood if binding involves the transmission of ϕ -features from the antecedent to the bound element via an intermediate functional head, Voice_{minimal} (cf. Kratzer 2009; Ahn 2015). Our discussion of the exceptional agreement behavior of

¹Glossing abbreviations: 1 = first person, 2 = second person, 3 = third person, ABIL = abilitative, ABL = ablative, ACC = accusative, CAUS = causative, COMP = complementizer, DAT = dative, GEN = genitive, LOC = locative, NEG = negative, NMLZ = nominalizer, NOM = nominative, PASS = passive, PL = plural, POSS = possessive, PROG = progressive, PST = past, SG = singular.

DTNs is a further empirical contribution of the paper, and our analysis of Relativized Case Opacity is an additional point of theoretical interest.

The paper's second goal is to further problematize the details of Agree-based theories of binding. One important question concerns the scope of Agree-based explanation: is Agree implicated in all instances of what has been termed anaphoric binding? We will argue that Turkish allows an empirical window into this question as well, this time motivating a negative answer. Crucial evidence to this end comes from the agreement-related behavior of anaphors embedded in Prepositional Phrases.

The paper is structured as follows.

Section 2 provides some preliminaries on the structure of Turkish nominalized clauses, before establishing the first empirical generalization of interest, Relativized Case Opacity: DTNs fail to control agreement when they are assigned genitive case. We provide an analysis of the structure of DTNs, and demonstrate how it conspires with the conditions under which genitive Case is assigned to lead to a situation of failed agreement. Taking pronouns and larger nominals to differ with respect to how ϕ -features are distributed in their structure, the analysis is based on the standard view that probes, too, can differ in their structure: person and number features on a single head may probe separately (yielding a *split* probe), or simultaneously (yielding a *composite* probe). We show how the two points of variation—bundling versus distribution of ϕ -features in pronominal structures, and split versus conjunctive probing in probes—conspire to derive the fact that genitive Case makes only DTNs, but not simplex pronouns, opaque to agreement.

Section 3 begins by introducing the second generalization of interest: case opacity is overridden when DTNs bind, such that a genitive-marked DTN in fact *can* control agreement, albeit only when it binds. We provide an analysis of this pattern, making crucial reference to the role of ϕ -features in binding. We argue that binding takes place early, before genitive assignment makes the DTN binder opaque. Because binding amounts to ϕ -feature transmission, it leaves its imprint on the structure, in the form of ϕ -features on the maximal projection of the head that mediates the antecedent/bindee relationship. It is these ϕ -features that may be targeted by a higher agreement probe, guaranteeing that co-varying agreement can emerge under binding. We go on to discuss implications of this analysis for the Anaphor Agreement Effect, and for the role of mediating heads in Agree-based theories of binding.

Section 4 considers the Turkish phenomenon in a wider context. We begin by briefly discussing and evaluating other pieces of evidence in favor of the role of Agree in binding, before addressing the question of whether Agree should be implicated in *all* instances of local binding. Data from binding into Turkish PPs reveals a limited role for Agree, whereby the operation is involved in the binding of arguments, but not adjuncts.

Section 5 summarizes our main points and concludes the paper.

2 Generalization 1: Relativized case opacity

2.1 Preliminaries

Since much of the discussion to follow revolves around nominalized clauses in Turkish, we provide some background on these here. For more extensive descriptions, the reader is referred to Borsley and Kornfilt (1999) and Kornfilt and Whitman (2011).

Nominalization is the most common complementation strategy in Turkish (and Turkic more generally; see e.g., Keleşir 2021). The bracketed portion of the example in (6) exemplifies a nominalized embedded clause:

- (6) (Ben) [sen-in sınav-ı geç-tiğ-in]-i san-ıyor-um.
 I you-GEN exam-ACC pass-NMLZ-2SG.POSS -ACC believe-PROG-1SG
 ‘I believe that you passed the exam.’ (Kornfilt 2007: 316)

Nominalized embedded clauses in Turkish are characterized by four properties. Firstly, when appearing in argument positions, they are overtly marked for Case by the matrix verb; for instance, in (6), the nominalized clause is marked accusative. Secondly, the embedded subject is marked with genitive Case. Moreover, nominalizing morphemes (*tiğ-* in (6)) are realized overtly, to the right of the Root. Finally, the nominalized verb agrees with its subject for person and number using the nominal exponents known as the possessive suffixes (e.g. *-in* above).

Nominalized clauses involve a large verbal/clausal base embedded under a nominal layer. The nominal layer ensures that the clause distributes as a nominal, thus freely appearing in argument positions, and that it receives overt Case-marking; additionally, the nominal layer must be responsible for the presence of the possessive suffixes and of genitive case on the subject, since both properties also appear in possessive NPs which, unlike nominalized clauses, are not verbal in any sense (see (19)–(20) below).

With respect to the size of the verbal base, nominalized clauses clearly embed a full verbal shell. Note firstly that the themes of nominalized clauses freely receive accusative (6). Moreover, these clauses allow the full range of argument structure alternations available in the language, including passives (7) and causatives (8):

- (7) Hasan [oda-nın (hizmetçi tarafından) temizle-n-diğ-in]-i söyle-di-∅.
 Hasan room-GEN servant by clean-PASS-NMLZ-3SG.POSS -ACC
 say-PST-3SG
 ‘Hasan said that the room was cleaned (by the servant).’
- (8) (Ben) [Hasan-in hizmetçi-ye oda-yı temizle-t-tiğ-in]-i söyle-di-m.
 I Hasan-GEN servant-DAT room-ACC clean-CAUS-NMLZ-3SG.POSS
 -ACC say-PST-1SG
 ‘I said that Hasan made the servant clean the room.’

Nominalized clauses can also embed negation:

- (9) (Ben) [sen-in sınav-ı geç-**me**-diğ-in]-i
 I you-GEN exam-ACC pass-NEG-NMLZ-2SG.POSS -ACC
 san-ıyor-um.
 believe-PROG-1SG
 ‘I believe that you didn’t pass the exam.’

Additionally, the nominalizing morpheme indexes a distinction sometimes referred to as factivity in the literature on Turkish (see Kornfilt and Whitman 2011: 1300; Predolac 2017). Clauses with the nominalizer *-DIK* as in the examples above are labeled as factive, while those with the nominalizer *-mE* (10) are labeled as non-factive.²

- (10) Hasan [uşağ-in oda-yı temizle-**me**-sin]-i söyle-di-∅.
 Hasan servant-GEN room-ACC clean-NMLZ-3SG.POSS -ACC say-PST-3SG
 ‘Hasan said that the servant should clean the room.’ (Kornfilt and Whitman 2011: 1300)

There is a third nominalizer, the so-called future *-(y)EcEK*.

- (11) Ben [siz-in tatil-e çık-**acağ**-ımız]-i duy-du-m.
 I you-GEN holiday-DAT go.out-NMLZ-2PL.POSS -ACC hear-PST-1SG
 ‘I heard that you will leave for vacation.’ (Borsley and Kornfilt 1999: 118)

These different nominalizing exponents can be treated as contextual realizations of the nominalizing morpheme determined by a high verbal head carrying modal features of some sort. What exactly the semantics of these features are, and whether “factivity” and “future” are the correct labels, is orthogonal to our discussion. Note that, since nothing of interest to this paper hinges on the factivity distinction, we do not gloss it in our examples.

We will thus take nominalized clauses to involve a verbal base consisting at the very least of VoiceP, embedded under a layer of nominal projections. The presence of VoiceP is crucial to the analysis to be developed in Sect. 3.2, but nothing hinges on the precise nature of any verbal projections intervening between VoiceP and the nominal layer, which we accordingly omit from our trees for convenience.³

2.2 Relativized case opacity

In the Turkish nominal domain, the agreement behavior of simplex pronouns differs from that of a class of complex pronominals which we will call *Default-Triggering*

²Capital letters indicate phonologically variable segments. Capital *I* represents a high vowel realized as *i*, *ı*, *ü* or *u*, and capital *A* or *E* represents a non-high vowel realized as *a* or *e*, according to the rules of vowel harmony. Capital *D* represents a dental-alveolar plosive that varies in voicing according to adjacent segments, whereas capital *K* represents a voiceless velar that might undergo phonological deletion in certain conditions even though it is orthographically represented as *ğ*.

³In fact, no conclusive evidence is available as to whether higher verbal layers, such as Aspect and Tense, are present. Predolac (2017) argues that nominalized clauses also involve a C projection, and that this C nominalizes the clause. Nothing hinges on the presence or absence of these projections for the account presented here, and we thus leave them aside.

Nominals (DTNs). Whereas pronominal subjects and possessors trigger co-varying nominal agreement on nominalized verbs and possessed nouns, respectively, DTNs yield default nominal agreement. This section is devoted to describing this agreement asymmetry, and showing that it is governed by the assignment of genitive Case.

The class of DTNs comprises structurally complex nominal elements that embed a pronoun in their structure.⁴

(12) *Default-Triggering Nominals (DTNs)*

- a. Multi-plural pronouns: *biz-ler* ‘we-PL,’ *siz-ler* ‘y’all-PL’
- b. Adnominal pronouns: e.g., *biz Türkler* ‘we Turks’
- c. Coordinations of local + nonlocal persons: e.g., *biz ile Leyla* ‘we and Leyla’

The agreement-related behavior of DTNs is in fact subject to systematic variation within our pool of consultants; we therefore begin by outlining this instance of variation, before proceeding to outline the pattern that is of interest here.

2.2.1 Preliminaries

Our pool of native Turkish-speaking consultants splits into three groups with respect to the properties of DTNs. For a first small group of speakers (*Grammar 1*; n=2, approx. 8% of our sample), DTNs are completely on a par with simplex pronouns, triggering full agreement in all environments and thus not being subject to case opacity. A second group of speakers, making up just under half of our consultant pool (n=12, 44%), shows the pattern of relativized Case Opacity, albeit without this configuration being repaired by binding (even though some speakers reported a contrast when the DTN acted as a binder). We refer to these consultants as speakers of *Grammar 2*. A third variety, the numerically predominant one in our sample (n=13, 48%), is made up of speakers for whom a) DTNs normally trigger default nominal agreement unless b) they bind. It is this variety, *Grammar 3*, that is the focus of this paper as represented by (3)–(5) above. Unless otherwise noted, judgments henceforth represent those of our Grammar 3-speaking consultants. See footnote 5 for additional notes on the data presented here.

Though our focus is Grammar 3, we touch upon other grammars, especially Grammar 2, when they provide insights. In particular, the analysis in this paper offers a way of understanding the source of the variation in agreement with DTNs. It is likely that speakers of Turkish divide into two groups with respect to the structure they assign to DTNs. As just mentioned above, Grammar 1 speakers seem to be analyzing

⁴That complex pronominals trigger default nominal agreement has been noted in previous work on Turkish, but only for a proper subset of DTNs at any one time: Ince (2008) and Aydın (2008) discuss partitives, and Satk (2020) discusses partitives and adnominal pronouns. Paparounas and Akkuş (2020) are the first to note the complete class of DTNs (minus coordinate pronouns, noted for the first time here). We leave out the discussion of partitives since their resemblance to other DTNs turns out to be only apparent, and they are subject to different conditions (see the end of this section for some discussion). A similar agreement asymmetry between pronouns and anaphors is observed in George and Kornfilt (1981) and Kornfilt (2007), leading Paparounas and Akkuş (2020) to classify anaphors with DTNs. However, although DTNs and anaphors both fail to agree in the nominal domain, they do so for different reasons; see Sect. 3.3.

them on a par with simple pronouns, and thus allowing them to agree; other speakers (Grammars 2 and 3) in turn may posit a more articulated analysis that interferes with agreement, as discussed in this section. We elaborate on the difference between Grammars 2 and 3 in Sect. 3.2.

2.2.2 Data

To illustrate the divergent behavior of pronouns and DTNs in the configurations of interest in Grammar 3, we contrast the simplex pronoun *biz* ‘we’ with its DTN counterpart *biz-ler* ‘we-PL’; the other DTNs (namely, adnominal and coordinate pronouns) behave identically, as we show in Sects. 2.3.4 and 2.3.5.

Simplex and multi-plural pronouns pattern together in requiring co-varying agreement in root clauses. In (13)–(14), both pronominal and DTN subjects trigger co-varying first-plural agreement on the verb.

(13) Biz oraya git-ti- { **k** / * \emptyset }.
 we there go-PST- 1PL 3SG
 ‘We went there.’

(14) Biz-ler oraya git-ti- { **k** / * \emptyset }.
 we-PL there go-PST- 1PL 3SG
 ‘We went there.’

Pronouns and DTNs also pattern together in embedded finite (verbal) clauses. Both exhibit co-varying agreement, as in (15)–(16), similarly to root clauses.

(15) Kemal [biz oraya git-ti- { **k** / * \emptyset }] san-dı- \emptyset .
 Kemal we there go-PST- 1PL 3SG think-PST-3SG
 ‘Kemal thought that we went there.’

(16) Kemal [biz-ler oraya git-ti- { **k** / * \emptyset }] san-dı- \emptyset .
 Kemal we-PL there go-PST- 1PL 3SG think-PST-3SG
 ‘Kemal thought that we went there.’

The two, however, diverge in embedded nominalized clauses. (17)–(18) illustrate the basic agreement asymmetry that characterizes Grammars 2 and 3: when in the subject position of an embedded nominalized clause, the pronoun triggers co-varying nominal agreement, whereas the DTN is only grammatical with default third-singular agreement.⁵

⁵As is standard, we use *ok/** to indicate contrasts in acceptability rather than absolute grammaticality judgements. We had twelve primary consultants who belong to Grammar 3 (in addition to one of the authors, Faruk Akkuş, who is a native speaker of Turkish). Data elicitation was carried out by means of various methods, initially with 27 speakers (both linguists and non-linguists; see Acknowledgements). Many consultants were presented with an informal questionnaire (in person, over emails or social media platforms) containing 42 sentences; others were asked a representative subset of those sentences (around 8–10) from which we were able to extrapolate the features of interest.

In the main text above we note that Turkish speakers split into three groups with respect to the behavior of DTNs. An anonymous referee notes that the speaker(s) they have consulted also belong(s) to Grammar 3, and another referee also notes their familiarity with all three grammars we mention here. We were not able to find any demographic factor (e.g., age, location, race) that correlates with the different grammars.

- (17) Kemal [biz-im oraya git-tiğ- { **imiz** / ***in** }]-i
 Kemal we-GEN there go-NMLZ- 1PL.POSS 3SG.POSS -ACC
 san-dı-∅.
 think-PST-3SG
 ‘Kemal thought that we went there.’
- (18) Kemal [biz-ler-in oraya git-tiğ- { ***imiz** / **in** }]-i
 Kemal we-PL-GEN there go-NMLZ- 1PL.POSS 3SG.POSS -ACC
 san-dı-∅.
 think-PST-3SG
 ‘Kemal thought that we went there.’

The same asymmetry is found in possessive constructions:

- (19) biz-im sınav- { **imiz** / ***ı** }
 we-GEN exam- 1PL.POSS 3SG.POSS
 ‘our exam’
- (20) biz-ler-in sınav- { ***imiz** / **ı** }
 we-PL-GEN exam- 1PL.POSS 3SG.POSS
 ‘our exam’

In (19)–(20), the possessors are in the genitive, much like the embedded subjects of (17)–(18). In (19), the possessum agrees with the pronominal possessor for person and number; but in (20), with a DTN possessor, the possessum can only show default third-singular agreement. Note that, although nominal agreement is hosted on nominalized verbs in (17)–(18) but on simple root nominals in (19)–(20), the agreement exponents are the same in both cases.

Table 1, to be revised, summarizes the observations made thus far. For the purposes of verbal agreement, pronouns and DTNs pattern together, obligatorily triggering full agreement. But under nominal agreement, pronouns and DTNs dissociate: the former continue to trigger full agreement, while the latter are only grammatical with default third-singular agreement.

This difference between nominal and verbal clauses correlates with the Case assigned to the subject of each. Notice that the subjects of verbal clauses (13)–(16) receive unmarked/nominative Case, whereas the subjects of nominalized clauses (17)–(18), like possessors (19)–(20), receive genitive. It is the genitive that blocks nominal agreement with DTNs, but not with pronouns.

More judgments were collected and confirmed during presentations at several Turkish-oriented or general conferences (see Acknowledgements), in which the audience members shared their judgments; for example, an on-site judgment collection was carried out during our presentation at Tu+ 5 (the Workshop on Turkic and languages in contact with Turkic). We found a similar distribution of Grammar 2 and Grammar 3 in these venues. Moreover, some of the examples were provided to us by native speaker linguists; we have noted this in the relevant examples. The paper also reports some attested examples found online, which were also confirmed by our consultants.

Finally, we found small-scale variation among the speakers of the variety reported here, Grammar 3, as to which of the forms are preferred. Many of our consultants reported that, even though 1PL and 3SG agreement are possible when a DTN binds, 1PL is preferable (see also fn. 42), though other consultants reported the opposite preference. We leave the preference issue and the variation aside for the most part, noting that variation within Turkish requires further study.

Table 1 Summary of agreement possibilities for pronouns and DTNs (to be revised)

	Verbal Agr		Nominal Agr	
	Co-varying	Default 3SG	Co-varying	Default 3SG
Pronoun	✓	*	✓	*
DTN	✓	*	*	✓

Evidence for this crucial involvement of Case comes from an asymmetry between adjunct and argument nominalized clauses. As Kornfilt (2003) observes, the subjects of argument nominalized clauses are in the genitive, but those of adjoined nominalized clauses are in the nominative:

- (21) Ben [**Ali-*(nin)** cam-1 kır-dığ-1 zaman]-1
 I Ali-GEN glass-ACC break-NMLZ-3SG.POSS time -ACC
 bil-iyor-du-m.
 know-PROG-PST-1SG
 ‘I knew when Ali broke the glass.’ (Aygen 2007: 2) (*argument*)
- (22) Ben [**Ali-*(nin)** cam-1 kır-dığ-1 zaman] gerçeğ-i
 I Ali-GEN glass-ACC break-NMLZ-3SG.POSS time truth-ACC
 bil-iyor-du-m.
 know-PROG-PST-1SG
 ‘I knew the truth when Ali broke the glass.’ (Aygen 2007: 2) (*adjunct*)

In (21), the nominalized clause functions as an embedded question in the object position of the matrix verb, and its subject is in the genitive, paralleling all examples seen so far. But in (22), where the nominalized clause is a temporal adjunct to the main verb, its subject must be nominative.⁶

This contrast between argument and adjunct nominalized clauses provides an ideal testing ground for the role that subject Case plays in determining agreement. Let us contrast the behavior of pronouns and DTNs in the subject position of adjunct nominalized clauses:

- (23) [[Biz yemek pişir-diğ-**imiz**]-den dolayı] konser-e
 we food cook-NMLZ-1PL.POSS -ABL because concert-DAT
 gid-e-me-di-m.
 go-ABIL-NEG-PST-1SG
 ‘Because we cooked, I was unable to go to the concert.’ (Kornfilt 2003: 151)
- (24) [[Biz-ler yemek pişir-diğ-**imiz**]-den dolayı] konser-e
 we-PL food cook-NMLZ-1PL.POSS -ABL because concert-DAT
 gid-e-me-di-m.
 go-ABIL-NEG-PST-1SG
 ‘Because we cooked, I was unable to go to the concert.’

⁶For discussion of *why* this contrast might obtain, the reader is referred to Kornfilt (2003) and Aygen (2007).

In (23), the nominative pronominal subject of the nominalized clause triggers co-varying agreement on the nominalized verb. This is expected, given that pronouns always trigger co-varying nominal agreement, even when marked with the genitive (17). Crucially, the nominative DTN subject in (24) *also* triggers co-varying nominal agreement. In fact, nominative DTN subjects of nominalized clauses *must* trigger co-varying agreement, as the contrast between (24) and (25) shows:

- (25) *[[Biz-ler yemek pişir-diğ-in]-den dolayı] konser-e
 we-PL food cook-NMLZ-3SG.POSS -ABL because concert-DAT
 gid-e-me-di-m.
 go-ABIL-NEG-PST-1SG
 ‘Because we cooked, I was unable to go to the concert.’

We thus observe that the agreement-related behavior of DTNs is determined by the Case assigned to them. When a DTN bears nominative, its ϕ -features are accessible for agreement: this is the case in verbal clauses (14)/(16) and adjunct nominalized clauses (24). But genitive Case blocks agreement with DTNs: this is why DTNs cannot trigger co-varying agreement in argument nominalized clauses (18) and possessive constructions (20). Pronouns differ from DTNs in that they can be agreed with both when marked nominative and when marked genitive. Table 2 summarizes this state of affairs, revising the preliminary description of Table 1 into the correct generalization that makes explicit reference to Case.

We follow Rezac (2008) in using the term *Case Opacity* to refer to situations where Case assignment to a nominal prevents that nominal from triggering co-varying agreement. The facts discussed so far are noteworthy insofar as they constitute an instance of Case Opacity that is *relativized*: genitive Case blocks agreement when assigned to DTNs, but not to simplex pronouns.⁷

- (26) *Generalization 1: Relativized Case Opacity*
 Genitive Case makes DTNs, but not pronouns, opaque for agreement.

Finally, note that the agreement behavior of pronouns contrasts with that of DTNs specifically, and not of larger DPs more generally. This is clearly seen with third-plural DPs, which pattern with pronouns, not DTNs. It is a general fact about the language that overt third-plural DPs optionally trigger plural agreement on the verb:

⁷One may wonder whether this effect is specific to genitive Case, or whether other (non-nominative) Cases also yield Case Opacity. The only other case subjects can carry in Turkish is accusative, in ECM constructions. Regardless of their category (i.e., common nouns, pronouns, DTNs), ECM subjects in Turkish bear accusative, and may show full or default agreement, as in (i).

- (i) Biz [sen-i oraya git-ti-(n)] san-dı-k.
 we you-ACC there go-PST-2SG think-PST-1PL
 ‘We thought you to have gone there.’

Moreover, this optionality does not interact with the presence/absence of a bindee, which is the focus of this study for DTNs (see Sect. 3). ECM presumably involves a different derivation in which the embedded subject raises either to the matrix object position (e.g., Zidani-Eroğlu 1997) or to the embedded CP (e.g., Şener 2008; Predolac 2017), and as such carries accusative case due to topicalized interpretations. For these reasons, we leave ECM aside.

Table 2 Summary of agreement possibilities for pronouns and DTNs (revised)

		Co-varying Agr	Default 3SG Agr
Pronoun	NOM	✓	*
	GEN	✓	*
DTN	NOM	✓	*
	GEN	*	✓

- (27) Onlar gel-di-(**ler**).
 they come-PST-PL
 ‘They came.’
- (28) Çocuk-lar gel-di-(**ler**).
 child-PL come-PST-PL
 ‘The children came.’

Plural agreement continues to be possible in the examples (29)–(30), which are the nominalized counterparts of (27)–(28), respectively:⁸

- (29) Biz [onlar-ın { gel-diğ-**in** / gel-dik-**lerin** }]-i
 we they-GEN come-NMLZ-3SG.POSS come-NMLZ-3PL.POSS -ACC
 söyle-di-k.
 say-PST-1PL
 ‘We said that they came.’
- (30) Biz [çocuk-lar-ın { gel-diğ-**in** / gel-dik-**lerin** }]-i
 we child-PL-GEN come-NMLZ-3SG.POSS come-NMLZ-3PL.POSS
 söyle-di-k.
 -ACC say-PST-1PL
 ‘We said that the children came.’

If third-plural pronouns and common nouns patterned with DTNs, (third-)plural agreement should be ungrammatical in (29)–(30), contrary to fact. As such, the correct generalization is that pronouns and common nouns pattern together to the exclusion of DTNs: the only nominals that fail to control agreement when marked with genitive are DTNs. More specifically, default agreement arises when the agreement controller is *a*) a local person pronoun embedded in a larger nominal structure (i.e., a multi-plural, adnominal, or coordinated local person pronoun) that is *b*) marked with genitive.

The focus of the paper is the binding/agreement interaction, which we describe and analyze in Sect. 3. However, before proceeding with that investigation, we discuss the internal structure of DTNs, and provide an analysis that correctly distinguishes DTNs from pronouns with respect to their agreement behavior. We take care to do justice to the properties of individual DTN constructions while trying to give an overarching

⁸In both root and nominalized clauses, such as (27) through (30), plural agreement is required with *pro* subjects. The presence or absence of agreement does not correspond to any obvious interpretive effect, including associative plural versus regular plural interpretations.

analysis that can apply to all three types of DTN. This analysis will provide enough of a scaffolding to support our ensuing analysis of the binding/agreement interaction, though the latter is not necessarily dependent on the details of the former.

2.3 Understanding relativized case opacity

Understanding relativized case opacity in Turkish amounts to understanding the interplay of two seemingly unrelated factors. The first is genitive assignment: on the one hand, agreement is blocked in environments where the genitive is assigned. On the other hand, this cannot be the only factor at play: if it were, both pronouns and DTNs would be opaque when marked with genitive, contrary to fact. We thus also need an account of the internal structure of simplex pronouns and DTNs, one that explains why the former agree both when nominative and when genitive, while the latter only agree when nominative.

In this section, we examine each of these two factors in turn.

2.3.1 Ingredient 1: The structure of (some) DTNs

We begin by developing the intuition that pronouns and larger nominals differ crucially with respect to how ϕ -features are distributed in their structure (cf. Ghomeshi and Massam 2020). For (local) pronouns, we posit that these involve bundling of interpretable person and number features on a single head, which we will label D (cf. footnote 24) along the lines of (31). This bundle is realized as in (32a): effectively, *biz* is the contextual realization of first person when the first person feature is local to number. In (31), first person and plural number are as local to each other as they can be; namely, they are on the same head. The plural feature itself is unrealized when on D, (32).⁹

- (31)
$$\begin{array}{c} \text{DP} \\ | \\ \text{D} \\ \left[\begin{array}{l} i\pi: 1 \\ i\#: \text{PL} \end{array} \right] \end{array}$$
- (32) a. $[1]_D \leftrightarrow /biz/ / [PL]$
 b. $[PL]_D \leftrightarrow \emptyset$

For common nouns, we adopt the structure in (33), which consists of a root, the categorizer *n*, and a number head, Num (Ritter 1991; Moskal 2015). Following one standard analysis of third person nominals (Kayne 2000; Harley and Ritter 2002; Béjar 2003; Anagnostopoulou 2005; Adger and Harbour 2007; Béjar and Rezac 2009; among many others), we assume that they lack person altogether; as such D (and its person feature *iπ*) is absent, and only *i#* is available on the Number head, which if plural is spelled out as *-lar*, shown in (34).

⁹For concreteness, and in keeping with work in Distributed Morphology (Halle and Marantz 1993 et seq.), we assume that the syntax only manipulates syntactico-semantic features of this kind, and that features are translated into phonological content post-syntactically by (possibly competing) Vocabulary Items.

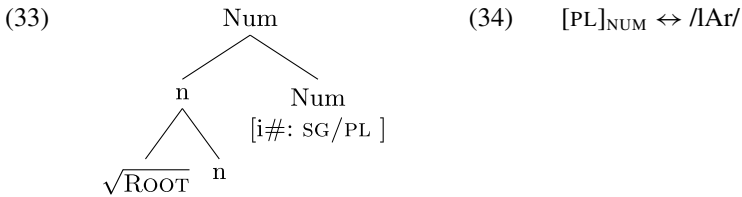

On the other hand, the structure of multi-plural pronouns and adnominal pronouns involves a pronominal determiner introducing a more articulated nominal structure, with ϕ -features distributed throughout this larger structure (see e.g. Moskal 2015 for one concrete proposal regarding the distribution of features across nodes in the nominal domain). On this view, simplex pronouns and DTNs crucially differ along one dimension: whereas in pronouns ϕ features are bundled on the same head, in DTNs the features are distributed over more than one head.¹⁰ We begin by developing this intuition for multi-plural pronouns and adnominal pronouns, reserving discussion of coordinate pronouns for Sect. 2.3.5.

Beginning with multi-plural pronouns, any account of their structure must begin from whether their semantics differs from that of simple pronouns. To our knowledge, no such difference exists.

Pairs like *biz* and *bizler* do not differ in terms of clusivity; they also do not differ in terms of collectivity/distributivity, unlike the associative plurals of Turkish (Ketrez 2010: 179).¹¹ The difficulty in discerning a clear semantic contribution for *-lAr* in *bizler* is reflected in claims that the plural exponent on pronouns is optional, found in the typological literature on Turkic (see Nevskaya 2010: 123–124 for a brief survey). Some speakers report that multi-plural pronouns have a more “emphatic” role, whose exact status, however, is hard to discern.¹²

As also pointed out by an anonymous referee, forms like *bizler* are marked for most speakers and in fact are considered substandard by some. However, apart from their pragmatic markedness, we do not believe that multi-plural pronouns have a different interpretation than simple pronouns. Prescriptive statements concerning the use of *bizler* in fact often use the lack of an interpretive difference between the two to justify the labeling of *bizler* as “redundant.”¹³ Such statements, we believe, are

¹⁰It is worth repeating that the distribution of ϕ -features in DTNs is a broad generalization we aim to capture, but DTNs do not necessarily form a natural class in terms of the fine details of *how* the features are distributed. As such, the distributed intuition may be manifested differently depending on the construction, especially in the case of coordinated pronouns discussed in Sect. 2.3.5.

¹¹DTNs are compatible both with exclusively distributive predicates, such as *be asleep* and *be tall*, and with collective predicates, which require pluralities, such as *agree*, *meet*, *scatter*, *separate*, or *surround*.

¹²A similar intuition is reported for the quantifier *herkes* ‘everyone,’ which can be attached the plural morpheme *-ler*.

(i) Herkes-ler nasıl-(lar) bakayım!
 everyone-PL how-PL let’s.see
 ‘Tell me, how is everyone!’

¹³For instance, the host of a popular Turkish comedy show *Çok Güzel Hareketler* reprimands his apprentices for using such forms, saying: “You should have criticized [the use of] ‘bizler,’ ‘sizler,’ [by the audi-

strong indications that the markedness of *bizler* is due to its being perceived as an alternant of *biz*, one that is redundant precisely because it is referentially equivalent to the simple pronoun.¹⁴

It is likely, then, that forms like *bizler* are “doubly plural” only in form, but not in meaning. We implement this intuition by assuming that, alongside being bundled together on the same head (31), there is an additional possibility regarding the structuring of person and number features: they can be contributed by separate nominal heads. As such, the D head in (35) differs from the one in (31) with respect to its feature make-up: while the pronoun in (31) carries both person and number features, the pronominal determiner in (35) is specified for person only. The number feature is then contributed by a separate head Num. For the purposes of interpretation, this structure guarantees that the resulting nominal is a plural pronoun like any other: the structure in (35) has one interpretable person feature and one interpretable number feature, just as (31) does. But the fact that the features are distributed in (35) guarantees a different realization compared to (31). (32a) will still apply to insert *biz* on D, since the person feature is local to number (this time, number is on a separate head, albeit one that will always be adjacent to D, both linearly and structurally). But since the number feature is now located on Num, (34) can apply, inserting *-lar*.¹⁵

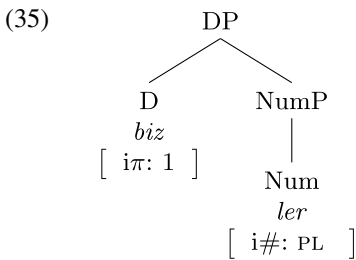

In other words, because there is only one interpretable number feature in the structure, (35) is not interpreted differently to (31); but because the independent number feature of (35) acts both as the context for insertion of *biz* and as the target for insertion of *-lar*, we get the superficial appearance of two instances of plurality at the point of exponence.

ence]... There is no such thing as ‘bizler,’ ‘sizler.’ ‘Biz’ and ‘siz’ are plural enough” (emphasis ours). This quote is from <https://www.youtube.com/watch?v=WaTyMWZrKlw>, 4’05”. The host brings up the same issue in the very next episode of the show: <https://www.youtube.com/watch?v=fkNfmzJIOQM>, 4’00”.

¹⁴An anonymous referee asks whether *bizler* and *sizler* could be associative plurals, meaning ‘we and our associates’ and ‘you and your associates,’ respectively. Though an interesting suggestion, this cannot be the case. It is possible to use such forms to refer to just two individuals, just like the regular pronoun *we*. It is of course sometimes suggested that plural pronouns can be interpreted in a way close to an associative, with *we* being decomposed into ‘I and others.’ In this case as well, whatever statement is made for *biz* would extend to *bizler*.

The genuine associative plurals of Turkish behave like other third-plural DPs mentioned towards the end of Sect. 2.2, in that they trigger 3PL agreement on the verb, which can be optionally dropped.

¹⁵We follow much current practice in accepting the arguments of Preminger (2011, 2014) (see also Bhatt 2005 on Hindi-Urdu) suggesting that unvalued uninterpretable features do not cause a crash, while also using interpretability as a diacritic clarifying where features get interpreted. We note, with Deal (2022), that this stance seems conceptually suspect, but cannot hope to resolve this wide-ranging tension here.

We consider this analysis to be simple and parsimonious. In particular, given the existence of two independent features, it might be the null hypothesis that they will be able to occur either bundled or separately on independent heads; from this perspective, Turkish does no more than attest both options in its pronominal system. The same may be true in other languages with double-marking of number of the relevant sort (Ghomeshi and Massam 2020: 601ff.).

In fact, in positing two ways of relating person and number—bundling vs. independent projection—we build directly on and extend the insights of Ghomeshi and Massam (2020), who argue on a cross-linguistic basis that number is projected independently in full nominals, leading to the semantics of individuation, but not in pronominals, where number is structurally subordinated to person. We take the wide-ranging differences between regular nominal and pronominal number discussed by Ghomeshi and Massam to be supportive of this conjecture, and add Turkish to their typology: as we will see, in Turkish, bundling (31) versus independent projection (35) lead not just to different distributions, but to the distinct agreement behaviors of pronouns versus DTNs.¹⁶

Consider now adnominal pronouns like ‘we Turks.’ These elements show the same behavior as other DTNs, as illustrated in (36) and (37): in the verbal clause in (36), the adnominal pronoun triggers co-varying agreement, whereas it fails to do so in the nominalized clause in (37).

- (36) Biz Türk-ler oraya git-ti- { **k** / * \emptyset }.
 we Turk-PL there go-PST- 1PL 3SG
 ‘We Turks went there.’
- (37) Kemal [biz Türk-ler-in oraya git-tiğ- { ***imiz** / **in** }
 Kemal we Turk-PL-GEN there go-NMLZ- 1PL.POSS 3SG.POSS
]-i san-dı- \emptyset .
 -ACC think-PST-3SG
 ‘Kemal thought that we Turks went there.’

Adnominal pronouns can be straightforwardly incorporated into the structure in (35): these involve an additional lexical layer below the functional projections for person and number, as in (38) (e.g. Höhn 2016, 2020; Satık 2020).¹⁷

¹⁶Under a minimally different conception of the structure of DTNs, D would bear an interpretable person feature and uninterpretable number feature valued by Agree with Num; the VI responsible for the insertion of *biz* would then target the person-number bundle on D. We do not believe that this alternative makes different predictions from the approach in the main text, which we prefer due to its potential to link the Turkish facts more directly to broader issues in nominal number of the kind discussed by Ghomeshi and Massam.

¹⁷The analysis in (38) finds support in the observation that multi-plural pronouns cannot be adnominal: **biz-ler Türk-ler* is ungrammatical (without an intonational break or pause; such a pause suggests an appositive parse, which is of course also available in the case of *biz Türkler* and thus orthogonal). This observation follows straightforwardly from the analysis of adnominal and multi-plural pronouns proposed here, where *-Ar* heads Num, and there is only one Num head available.

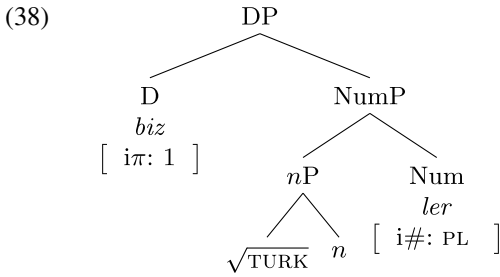

2.3.2 Ingredient 2: The structure of probes

With the structure of DTNs in place, the second ingredient of our analysis of Relativized Case Opacity concerns the nature of Case assignment in the nominal versus the verbal domain. A first crucial assumption involves the nature of the structures where nominative and genitive Case are assigned. Following Kornfilt and Preminger (2015), we take nominative to correspond to syntactic Caselessness: nominative is unmarked in the deep sense, in that it corresponds to the lack of Case on a nominal. This type of solution is fully consistent with the fact that the exponence of nominative in Turkish and related languages is systematically null.

The prototypical nominative-bearing context is thus schematized in (39): the verbal agreement probe T bears no Case feature whatsoever, and the Agree operation between T and the closest DP results in valuation of the former’s unvalued uninterpretable ϕ -features without Case assignment to the nominal.

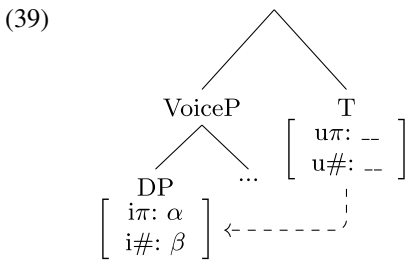

Recall from (22)–(24) that nominative can also be present in embedded nominalized clauses, where the agreement suffixes are not those that would realize T in (39), but are rather drawn from the Turkish nominal agreement paradigm. We take the relevant exponents to realize a distinct probe Poss (e.g., Kornfilt 1984, 1997; Arslan-Kechriotis 2006, 2009; Kunduraci 2013), which is effectively the nominal counterpart of T. In adjunct nominalized clauses, then, where the subject is realized as nominative/unmarked, the structure is of the following type, abstracting away from any additional verbal layers between Voice and the nominalizer *n*.

(40)

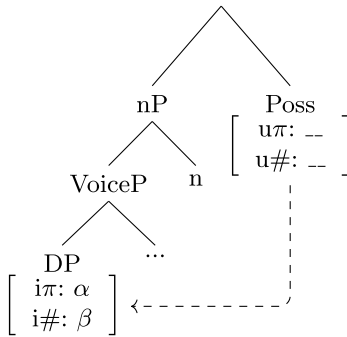

What about the arguably more frequent case, where the subject of the nominalized clause is genitive? Recall that we need these clauses, too, to be realized with the nominal agreement suffixes; in other words, Poss must be present here, too. What about the Case-marking of the subject? Clearly, genitive cannot be assigned by Poss, since Poss is present in (40) as well; in other words, genitive Case assignment does not go hand in hand with nominal agreement, therefore genitive Case assignment cannot be tied to the presence of the head responsible for nominal agreement. Recall that in adjunct nominalized clauses, as shown in (22), the two functions are dissociated in that nominal agreement obtains in the absence of genitive. As such, when genitive *is* assigned, namely, in argument nominalized clauses, a different head (call it Gen) must be responsible for this function. This assumption vis-à-vis the state of affairs in (39)-(40) is, we believe, straightforwardly tied to the fact that nominative in Turkish is always morphologically null, but genitive never is. See Satık 2020 for the same dissociation in Turkish (as well as Kornfilt 1984; Arslan-Kechriotis 2006; cf. Lim 2022 for further evidence from Khalkha Mongolian).

We further assume that, although agreement can take place without Case assignment, as in (39), Case assignment must be accompanied by an instance of Agree; in other words, Case-assigning functional heads are probes. More precisely, we assume that once a Case is assigned, an Agree operation is triggered; though this cycle of Agree is obligatory, it need not be successful (Preminger 2014), and because the assignment of the Case feature precedes the initiation of the Agree operation, whether Agree fails or not has no bearing on the success of Case assignment.

Applied to the structure we have been sketching, the assumption that Case assignment is accompanied by a later operation of Agree entails that Gen, the genitive-assigning head, bears unvalued ϕ features, as in (41). These features will initiate a cycle of Agree; if this operation is successful, Gen will copy the DP's ϕ features, and Poss will subsequently inherit those same ϕ features from Gen, which is the closest goal to Poss. If Gen fails to acquire the DP's ϕ features for whatever reason, then Gen will also be unable to transmit these ϕ features to Poss. We further assume that Gen and Poss are phase heads: when Poss is merged, the complement of Gen is spelled out. As such, Poss cannot probe the DTN directly, and Gen is effectively the only possible goal for Poss (see Bhatt 2005; Bhatt and Walkow 2013 for a very similar

type of dependency between multiple functional heads, e.g., T and Asp, in terms of uninterpretable ϕ -features in Hindi-Urdu).¹⁸

(41)

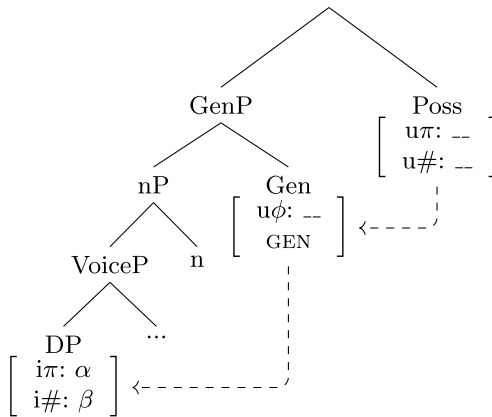

From this perspective, the differences between agreement in the verbal versus the nominal domain are as follows: although nominative corresponds to Caselessness, genitive is assigned by a functional head distinct from the agreement probe (recall that this is empirically motivated by adjunct nominalized clauses, which have nominal agreement but lack genitive Case). As a result, in argument nominalized clauses, agreement is *mediated*: when Gen is present, Poss can never agree with the subject DP directly, and can instead only agree with Gen.¹⁹

We can now begin to glimpse the gist of our solution to the puzzle of relativized Case Opacity: it hinges on the role of Gen. We will argue that, in a structure like (41), the ϕ probe on Gen can be valued by the features of DP when DP is a simplex pronoun, but not when it is a DTN. When the DP is a pronoun, Gen will receive its ϕ features, and Poss will subsequently receive the same ϕ features when it probes GEN; but when the DP is a DTN, it must be the case that Gen, and thus Poss, cannot receive any ϕ features, leading to the emergence of default agreement. We thus continue by elaborating on why Gen cannot be valued by DTNs.

Recall from the immediately preceding section that pronouns and DTNs differ with respect to how ϕ features are organized in the nominal structure. When person and number are bundled on the same head, the result is a simplex pronoun; when the same features are distributed over the nominal structure, with number being contributed independently from person, the result is a DTN, as illustrated above with multi-plural and adnominal pronouns. In the rest of this section, we take this difference in the organization of ϕ features to be responsible for the differential behavior of pronouns and DTNs when they interact with the Gen probe. The aim is to lend substance to the intuition that this section began from, namely, that relativized Case

¹⁸Bhatt and Walkow (2013) do not invoke phasehood in their discussion, and simply state it as a requirement that a higher functional head accesses the features of the goal only via dependency with intermediate functional head. This is the point that we adopt regarding the dependency of Poss and Gen.

¹⁹In adjunct nominalized clauses, where Gen is absent, Poss is able to probe the DTN directly, as no phase boundary intervenes between the two.

Opacity follows not from either the assignment of genitive or the structure of DTNs alone, but from the interaction between these two factors.

To implement this intuition, we draw a crucial distinction regarding the nature of features on probes. Note that, in (41), we represent the probe on Poss as two distinct person and number features, but we represent Gen with a single composite ϕ probe. This notational difference is intentional: heads may bear distinct (*split*) probes for person and number, or a single *conjunctive* (or *composite*) probe, such that person and number probe together. Both options have been independently proposed in the literature (e.g., Béjar 2003; Béjar and Rezac 2009; Coon and Bale 2014; Preminger 2014; Van Urk 2015), with many studies gaining syntactic mileage out of the difference between split and conjunctive probing. For instance, Coon and Bale (2014) argue that Agree may sometimes involve multiple features, which happen to be person and number in Mi'gmaq (an Algonquian language), acting as a composite probe.²⁰

Given that both types of probes have been argued to be available, we expect that languages may choose to treat distinct probing features on one head as composite or separate (see also e.g. Martinović 2022 for this idea implemented to Wolof). We propose that both options are available in Turkish, and that the choice between them is furthermore relativized to the nature of the head on which these features are located. Specifically, on dedicated agreement probes such as T and Poss, which are the verbal and nominal counterpart of each other, π and # function as separate probes (following Ince and Aydın 2015); but on the case-assigning head Gen, they form a conjunctive, bundled probe. We will use the notational convention in (42) to reflect this difference, representing split probes using separate branches for person and number solely for expository purposes; when space prohibits this type of representation, we will notate split probes as separate [u π : __] and [u#: __] features under the same node, again to be distinguished from the composite [u ϕ : __].

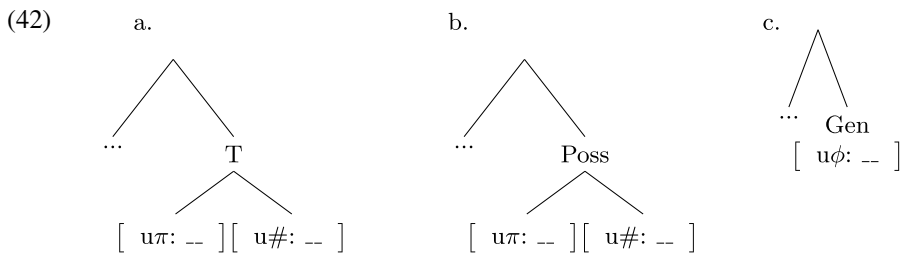

Person and number will thus probe separately when found on T or Poss, but will act as one probe when on Gen. Adopting Cyclic Agree, and following Béjar (2003, 2008) and Béjar and Rezac (2009), we take it that Agree is subject to the condition that in each cycle of search, a probe must find a goal that exhaustively matches its specifications in order to be valued. Agree will thus fail when the feature structure of the goal is less specified than that of the probe. More specifically, in the case of partial matching, where only a proper subset of the features that the probe needs are

²⁰Béjar (2008) implements a version of this intuition where conjunctive vs split probes may be present a single head, on the basis of an entailment relationship between the probe features.

available on the goal, the probe does not copy any features (see also Adger 2010). However, this failure to be valued does not lead to a crash, with unvalued features surviving to PF, where they receive a default value (Preminger 2014).

Coupled with the postulation of split versus composite/conjunctive probes, the no-partial-copying condition on Agree plays a crucial role in explaining why DTNs trigger default agreement in the domain of the Gen head, but full agreement elsewhere. Let us begin illustrating the analysis with simple pronouns and common nouns, before turning to DTNs.

Simple pronouns will be able to satisfy both split and conjunctive ϕ probes. In pronouns, interpretable π and # features are bundled on the same D head. The split probes will probe successively, and each will find its matching feature on D. Importantly, the more stringent conjunctive probe, which requires that its goal bear both interpretable person and interpretable number, will also be satisfied, since person and number are bundled in pronouns. This situation is schematized below. In (43), each of the split probes of T have found their matching feature on the pronoun; in (44), Gen has successfully acquired the pronoun’s features, and Poss, by probing Gen, will successfully acquire them as well.²¹

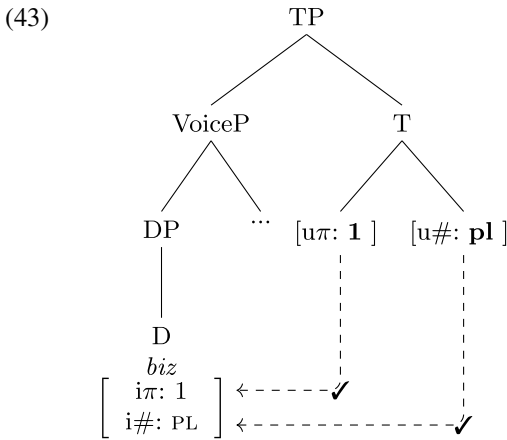

²¹The capacity of Poss to be valued by Gen in this way means that uninterpretable features more generally should be able to value probes. This is not an additional assumption; rather, it is fully in line with the idea of Failed Agree and the role that uninterpretability plays in our system, namely, as a convenient diacritic and little more; see footnote 15.

(44)

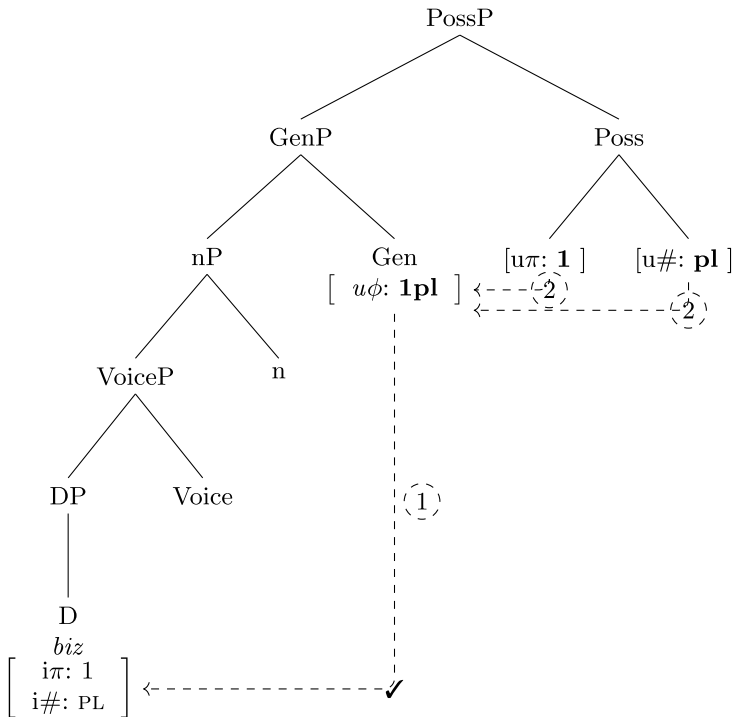

Adjunct nominalized clauses would have the structure in (44), but without Gen; as such the $u\pi$ and $u\#$ features on Poss would directly probe their matching interpretable counterparts on D.

Note a crucial assumption necessary to derive the correct realization of nominal agreement: in nominal structures like (44), there can be two valued probes (namely, Gen and Poss), but we only ever find one set of ϕ features realized on the nominalized verb. It must be the case, then, that ϕ features on Gen are never realized. We leave open the exact mechanism that guarantees this, noting that a post-syntactic rule such as Impoverishment would have to be responsible.

Before turning to DTNs, and to contextualize that discussion, we first detail the behavior of common nouns. Recall that common nouns (as well as third person pronouns) also trigger full agreement in nominalizations. To capture the contrast between local persons, as found in DTNs, and non-local persons, we enrich the featural content of Gen, noting that in addition to the composite $[u\phi]$ probe, it can also bear only the $[u\#]$ feature. The choice between the different featural contents of Gen depends on the nominal it combines with, and we implement this relationship as a selectional restriction.²²

²²The aim here is to ensure that the probe is sensitive to the goal's feature, in a way that does not strictly depend on sisterhood since there might be intervening projections that are not relevant to this dependency. For example, Voice could be present structurally between Gen and NumP, but it does not act as an intervener for the relevant dependency. Various ways of capturing this are conceivable which are all compatible with our system. We simply follow Adger (2010), Cowper (2010), Pietraszko (2016) in assuming that

Relevant to our purposes is that the Gen head bearing the conjunctive $[u\phi]$ selects for a DP, a goal that contains the interpretable person feature. Therefore, in the context of a DP, the Gen head with the conjunctive probe is inserted. The Gen head with the sole $[u\#]$ feature combines with NumP, which we use as a shorthand for phrases that lack the person feature (which, in the privative person system we assume, correspond to third person).²³ As such, in the context of common third-person nouns, the Gen head will simply have the $[u\#]$ feature, (45). Note that this is in line with a commonly assumed entailment relationship between ϕ -features: the presence of person entails number, but not the other way around (Harley and Ritter 2002; Béjar 2003; Béjar and Rezac 2009; Coon and Bale 2014; Deal 2022, i.a.). This guarantees it is impossible to have a probe (Gen or another) with a person feature but not a number feature, which crosslinguistically seems to be a correct prediction, as the aforementioned studies also demonstrate.

(45)

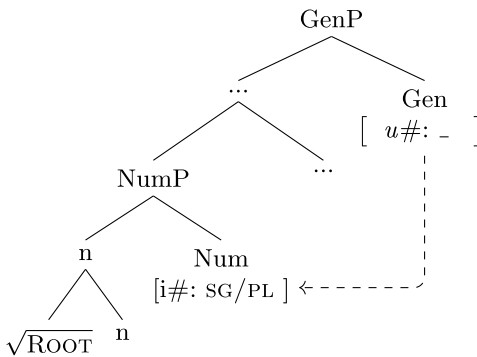

To summarize, the Gen head can host either a conjunctive probe or only a number probe, and these probes are inserted in different contexts. The conjunctive probe selects for a DP, whereas the Gen head with only the $[u\#]$ feature selects for NumP, as shown in (46).²⁴ As we will demonstrate shortly, this assumption proves instrumental

c(ategorial)-selection is not solely based on sisterhood, but can also be “long-distance” (see these works for more details). Adger (2010) casts this relationship in terms of featural interaction over the course of structure building, in that an uninterpretable feature demands the presence of its counterpart elsewhere in the structure. This ensures that even when the probing head does not immediately c-command the goal, the relevant selectional properties apply.

Specifying a probe in relation to the goal it establishes a dependency with is not novel. The implementation of Agree-based binding in Kratzer (2009) assumes that the same functional head can have two versions, one that bears a λ -binder and one that does not, the choice of which depends on whether a minimal pronoun is merged lower in the structure. See Kratzer (2009) and Sect. 3.4 below for more discussion.

²³This approach is due to Rajesh Bhatt (p.c.). Note that such a relativization could be extended to the T probe as well; this would not lead to a difference given our Turkish data, so we proceed assuming a single T head, with no featural variation.

²⁴This proposal tracks a similar intuition to that captured in the PCC literature by means of the Person Licensing Condition (PLC, Béjar 2003; Rezac 2008; Preminger 2014, a.o.), which states that the interpretable person feature on local pronouns must be licensed.

As Rajesh Bhatt (p.c.) notes, it is possible to relabel DP as PersonP, since the person feature effectively is what distinguishes local person DPs from common nouns and third person pronouns. We maintain the label DP, but accord with that intuition.

in understanding the intricate behavior of coordinate pronouns, bringing them in line with the other DTNs.

- (46) a. Gen [$u\phi$]
selects for DP
- b. Gen [$u\#$]
selects for NumP

Given this background, we now turn to DTNs. We will examine the DPs making up this class in turn; these are listed in (12), repeated here as (47).

- (47) *DTNs*
- Multi-plural pronouns: *biz-ler* ‘we-PL,’ *siz-ler* ‘y’all.PL-PL’
 - Adnominal pronouns: e.g., *biz Türkler* ‘we Turks’
 - Coordinations of local + nonlocal persons: e.g., *biz ile Leyla* ‘we and Leyla’

2.3.3 Multi-plural pronouns

Coupled with the structure of probes developed in the previous section, the structure of multi-plural pronouns, where person and number are contributed by different heads, guarantees that these trigger full agreement in the verbal domain, but default agreement in the nominal domain. Let us illustrate first with the derivation of full agreement in finite clauses. On the T head, $u\pi$ and $u\#$ probe separately, and both independently find their full match. The person probe finds the interpretable person feature on D, and the number probe the number feature on Num. These derivational steps are sketched in (48). The combination of first person and plural features on T will be spelled out as the 1PL affix *-k* at PF.

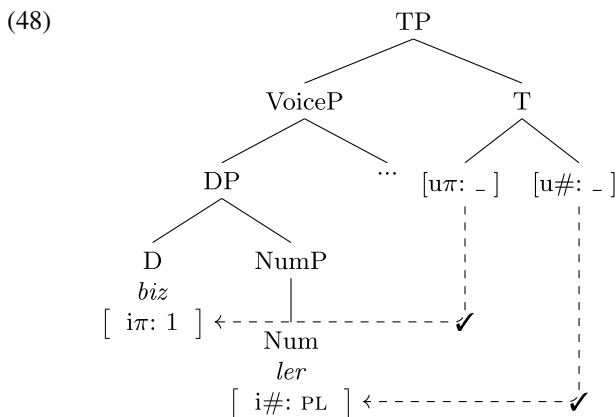

Consider now the behavior of multi-plural pronouns under the nominal probes Gen and Poss. Since it is merged with a DP, Gen will have the conjunctive probe, with

person and number probing together. As such, when Gen probes, only a goal that has both π and # bundled on the same head can value it. This condition imposes a strong restriction: there is no way to value the conjunctive probe in this structure. Assume that the conjunctive probe finds the closest goal, which will be the $i\pi$ feature on D. Since D contains only a proper subset of the features needed to value the Gen head, Gen cannot be valued. A second cycle of Agree is initiated, but also fails to value the Gen head. The reason is that Num, the next available goal, only contains $i\#$, and not both of the features needed to value the probe. Since both cycles of the search fail, Gen will remain unvalued. This derivation is sketched in (49).²⁵

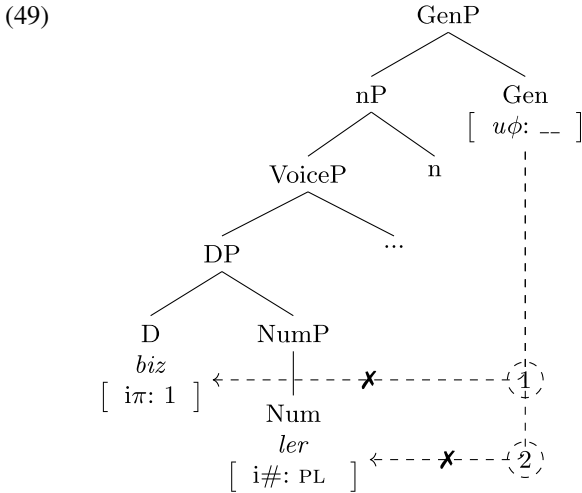

By the time Poss enters the structure, as shown in (50), the complement of Gen will have been spelled out. Since the only available goal, Gen, is empty, Poss will itself not be valued, and will receive default third singular values at PF (Preminger 2014).

²⁵It must be the case that DP does not collect the person feature from D, and the number feature from Num; this seems sensible, insofar as, if any percolation takes place, it will plausibly be from the head (e.g. D) to the phrase (e.g. DP), but not from a different head (e.g. Num) to DP. Note that there is independent evidence from agreement with coordinations against this type of across-the-board feature percolation from distinct projections in Turkish; see (66) below.

(50)

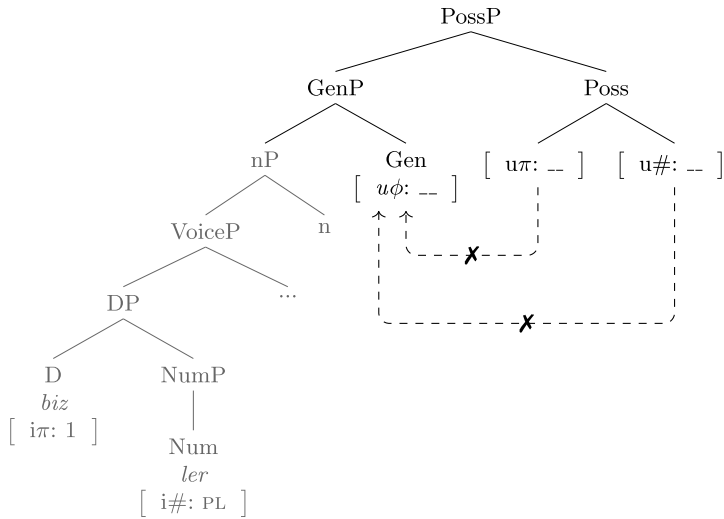

2.3.4 Adnominal pronouns

The derivation of adnominal pronouns will proceed in the same way as with the multi-plural pronouns just discussed. When T probes, each part of the split probe will find its interpretable feature counterpart on a different head, as shown in (51) (cf. (48)).

(51)

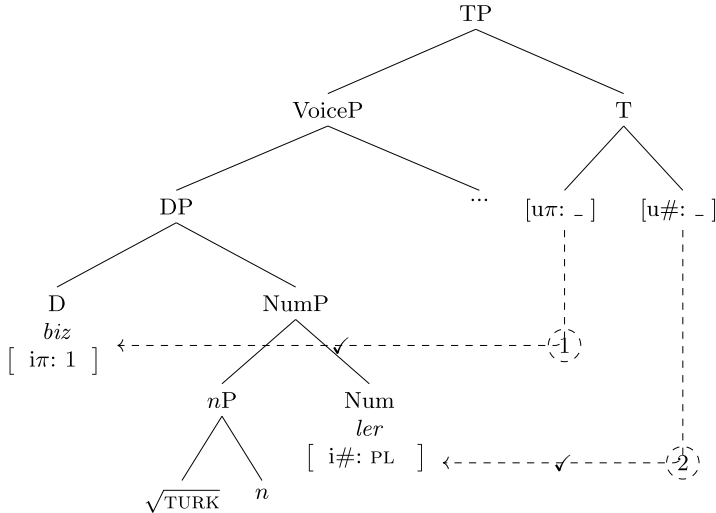

Consider now the derivation when the probe is Gen, (52), before Poss is merged. In the first cycle, the conjunctive probe will fail to find both person and number as the D head only contains the interpretable person feature; the second cycle of probing will have the same fate, since Num only carries a number feature. Thus, in neither cycle of the search does the goal exhaustively match the specification of the conjunctive probe, causing Gen to remain unvalued. Similar to the situation with the multi-plural

pronouns, by the time Poss enters the structure in a later stage of derivation, the complement of Gen will have been spelled out; therefore, Poss will itself not be valued, and will receive default third singular values at PF.

(52)

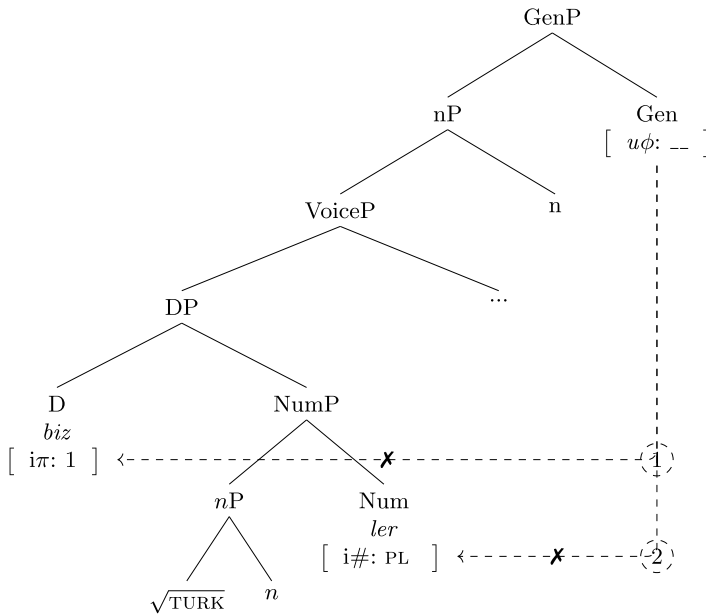

Overall, multi-plural pronouns and adnominal pronouns involve very similar derivational steps and trigger default agreement for the same reason.

2.3.5 Coordinate pronouns

The final DTN comes in the form of certain coordination patterns, e.g. *biz ile Leyla* ‘we and Leyla.’ Like the other DTNs, coordinate pronouns trigger full (resolved) agreement in finite clauses, and default agreement in the nominal domain. But their behavior shows certain further intricacies: default agreement occurs only in certain combinations of conjuncts, namely, only in conjunctions of local and non-local persons. We will show how these more complex patterns emerge as natural consequences of our system as developed thus far.

We first introduce the patterns we find in finite clauses (matrix and embedded) with various person combinations which are representative of the overall paradigm in coordination (leaving out some number combinations and conjunct orders since number resolution consistently leads to plural, and the order of conjuncts has no effect). The examples in (53) through (55) replicate the person hierarchy noted for copular structures in Turkish (Ince and Aydın 2015), as follows.

Combinations of local persons (1+2, or 2+1) trigger resolved first-plural agreement (53).²⁶

²⁶We use the coordinator *ile* ‘and,’ which forms pluralities out of entities by summing them (cf. sum formation operator, Link 1983) although the other coordinator *ve* ‘and’ behaves identically in these con-

(53) *local+local*

- a. Ben ile sen piyano-yu beraber taşı-dı-k.
I and you.SG piano-ACC together carry-PST-1PL
'I and you carried the piano together.'
- b. Sen ile ben piyano-yu beraber taşı-dı-k.
you.SG and I piano-ACC together carry-PST-1PL
'You and I carried the piano together.'
- c. Biz ile sen piyano-yu beraber taşı-dı-k.
we and you.SG piano-ACC together carry-PST-1PL
'We and you carried the piano together.'
- d. Sen ile biz piyano-yu beraber taşı-dı-k.
you.SG and we piano-ACC together carry-PST-1PL
'You and we carried the piano together.'
- e. Biz-ler ile sen piyano-yu beraber taşı-dı-k.
we-PL and you.SG piano-ACC together carry-PST-1PL
'We and you carried the piano together.'

When local persons combine with nonlocal persons (1/2+3, or 3+1/2), the local person feature is realized (54).

(54) *local+nonlocal*

- a. Ben ile Leyla/o piyano-yu beraber taşı-dı-k.
I and Leyla/(s)he piano-ACC together carry-PST-1PL
'I and Leyla/(s)he carried the piano together.'
- b. Sen ile Leyla/o piyano-yu beraber taşı-dı-nız.
you.SG and Leyla/(s)he piano-ACC together carry-PST-2PL
'You and Leyla/(s)he carried the piano together.'
- c. Leyla/o ile sen piyano-yu beraber taşı-dı-nız.
Leyla/(s)he and you.SG piano-ACC together carry-PST-2PL
'Leyla/(s)he and you carried the piano together.'
- d. Biz-ler ile Leyla/o piyano-yu beraber taşı-dı-k.
we-PL and Leyla/(s)he piano-ACC together carry-PST-1PL
'We and Leyla/(s)he carried the piano together.'

Finally, when nonlocal persons are coordinated (3+3), they trigger optional third plural agreement, (55) (see fn. 8 for this optionality in Turkish).

(55) *nonlocal+nonlocal*

- a. Hasan ile Leyla piyano-yu beraber taşı-dı-(lar).
Hasan and Leyla piano-ACC together carry-PST-3PL
'Hasan and Leyla carried the piano together.'
- b. O ile Leyla piyano-yu beraber taşı-dı-(lar).
(s)he and Leyla piano-ACC together carry-PST-3PL
'(S)he and Leyla carried the piano together.'

figurations. Note that we do not mean that *ile* and *ve* behave identically in all contexts in Turkish, since *ve* has the distribution of a general-purpose coordinator like English *and*, while *ile* can only conjoin NPs to form pluralities.

- c. Leyla ile o piyano-yu beraber taşı-dı-(**lar**).
Leyla and (s)he piano-ACC together carry-PST-3PL
'Leyla and (s)he carried the piano together.'
- d. O_i ile o_k piyano-yu beraber taşı-dı-(**lar**).
(s)he and (s)he piano-ACC together carry-PST-3PL
'(S)he_i and (s)he_k carried the piano together.'

These patterns demonstrate that in the verbal domain, agreement resolution rules in Turkish are unremarkable in that they replicate the patterns commonly observed crosslinguistically: $1&2 > 1$, $1&3 > 1$, $2&3 > 2$, $3&3 > 3$, irrespective of the order of conjuncts. The interesting pattern arises when we examine coordination in the nominal domain.

Let us thus turn to nominalized clauses; these for the most part parallel the behavior observed in root clauses, and we thus provide the nominal counterparts of a representative subset of (53)–(55). Combinations of local persons trigger first plural agreement (56), and conjunction of nonlocal persons triggers optional third plural agreement, as in (57).

- (56) Herkes [ben ile sen-in piyano-yu beraber taşı-dığ-**ımız**
everyone I and you.sg-GEN piano-ACC together carry-NMLZ-1PL.POSS
]-1 gör-dü.
-ACC see-PST
'Everyone saw that I and you carried the piano together.'
- (57) Herkes [Hasan/o ile Leyla-nın piyano-yu beraber
everyone Hasan/(s)he and Leyla-GEN piano-ACC together
taşı-dık-(**lar**)-ın]-1 gör-dü.
carry-NMLZ-(PL)-POSS -ACC see-PST
'Everyone saw that Hasan/(s)he and Leyla carried the piano together.'

The striking contrast between verbal and nominal clauses is seen when we consider combinations of local and non-local persons, e.g., a coordinate phrase like 'I and Leyla/she.' While this coordination triggers first plural agreement for all speakers in verbal clauses (cf. (54)), for speakers of Grammar 3, the same phrase fails to trigger resolved agreement when it is the subject of an argument nominalized clause, as shown in (58) and (59).^{27,28}

²⁷The use of */?? is aimed to reflect Grammar 3 similar to the other DTNs discussed above. Such combinations are acceptable for speakers of Grammar 2.

²⁸Expectedly, a similar contrast is observed in possessive constructions as well (the coordinator *ile* can lean to the leftward host as a morphophonological clitic):

- (i) ben-le sen-in ara- { **mız** / ***sin** } -da-ki fark
I-and you-GEN between- 1PL.POSS / 3SG.POSS LOC-MOD difference
'I and your's difference (i.e., the difference between I and you).'
(The attested form is retrieved from doktor (@Furkan_kzu) / Twitter)
- (ii) ben-le o-nun ara- { ***mız** / **sin** } -da-ki fark
I-and (s)he-GEN between- 1PL.POSS / 3SG.POSS LOC-MOD difference
'I and (s)he's difference (i.e., the difference between I and (s)he).'

- (58) Herkes [ben ile Leyla-nın piyano-yu beraber taşı-dığ-**ın**
 everyone I and Leyla-GEN piano-ACC together carry-NMLZ-3SG.POSS
 / ??taşı-dığ-**ımız**]-ı gör-dü.
 carry-NMLZ-1PL.POSS -ACC see-PST
 ‘Everyone saw that I and Leyla carried the piano together.’
- (59) Herkes [biz-ler ile Leyla-nın piyano-yu beraber
 everyone we-PL and Leyla-GEN piano-ACC together
 taşı-dığ-**ın** / ??taşı-dığ-**ımız**]-ı gör-dü.
 carry-NMLZ-3SG.POSS carry-NMLZ-1PL.POSS -ACC see-PST
 ‘Everyone saw that we and Leyla carried the piano together.’

As with the other DTNs, when coordinate pronouns are nominative subjects of adjunct nominalized clauses, they do agree:

- (60) *pro* [ben ile Leyla-(*nın) yemek *pişir-diğ-**ın** /
 I and Leyla-(*GEN) food cook-NMLZ-3SG.POSS
 pişir-diğ-**ımız**]-den dolayı konser-e gid-e-me-di-k.
 cook-NMLZ-1PL.POSS -ABL because concert-DAT go-ABIL-NEG-PST-1PL
 ‘Because I and Leyla cooked, we couldn’t go to the concert.’

The patterns thus far are significant for several reasons. They make it clear that the factor responsible for default agreement with coordinate pronouns is not coordination itself, since resolved agreement is possible in many combinations of conjuncts even with the Gen head. Rather, resolved agreement is disallowed in a particular set of circumstances, namely, when a local and a nonlocal person are conjoined.

A satisfactory analysis should do justice to the subtleties inherent in the facts discussed here. The approach we sketched above, involving insertion of a Gen probe with a certain featural content, depending on the nominal it combines with, plays a crucial role in explaining the interesting behavior of local+nonlocal coordination. (61) repeats (46), stating that when Gen selects a DP, which has both person and number features, it hosts the conjunctive probe [$u\phi$]. On the other hand, when Gen combines with a phrase that lacks the interpretable person feature, but has only number, its probe is specified as [$u\#$].

- (61) a. Gen [$u\phi$]
 combines with DP
- b. Gen [$u\#$]
 combines with NumP

To preview our analysis, we suggest that selection of the featural content of Gen in coordination proceeds as follows. If either of the conjuncts is a DP (i.e. is a local person nominal), the Gen head with the conjunctive probe [$u\phi$], (61a) will be inserted. Otherwise, the Gen head bearing just the $u\#$ will be inserted, (61b). The

As an aside, in (i), the default third singular possessive becomes possible if the local pronouns are interpreted in a meta-linguistic sense, to mean “the difference between the pronouns/forms ‘I’ and ‘you’...” rather than indexical pronouns referring to the speaker and the hearer.

presence of a DP in one of the conjuncts will trigger the insertion of the conjunctive probe. This probe will be valued by the DP conjunct, but will not be able to be valued by the NumP conjunct, leading to non-resolution and, ultimately, insertion of default third-singular values. This way, the system incorporates the ingredients and mechanism employed for other DTNs, and attributes the emergence of default agreement with local+nonlocal coordination to a problem of non-resolution that arises when we attempt to coordinate ‘unlikes.’ This state of affairs helps explain why default agreement is triggered only in combinations of local and non-local conjuncts: the intuition of the analysis below is that local+nonlocal coordination leads to default agreement because the probe cannot satisfy the conflicting requirements of the two conjuncts.

With this in mind, let us turn to the analysis itself.

Following a standard analysis of coordinate structures, we take it that coordination is the projection of a & head whose specifier and complement are filled by the first and second conjunct, respectively (e.g., Munn 1993, 1999; Benmamoun et al. 2009; Marušič et al. 2015), as shown in (62). We also assume, with Citko (2018) and Al Khalaf (2021), that neither & nor &P bear ϕ -features, and that no feature percolation is operative in coordination. As such, external probes target the conjuncts themselves via Agree, similar to summative agreement in right node raising (e.g., Grosz 2015), rather than targeting the maximal projection &P that collects the features of the conjuncts.²⁹

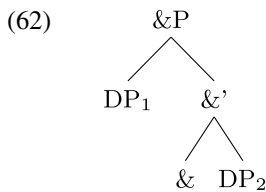

When a coordination is probed directly by the split probes, T or Poss, the derivation will proceed unproblematically: the person probe will access the person features of each conjunct in turn (when the coordination does not involve a third person nominal), or of just the local person (when we are coordinating a local and a non-local person). The number probe will access the number feature of each conjunct in turn, since both conjuncts will always bear number. Once T/Poss has collected the relevant set of features, the feature resolution algorithm will apply. The important point is that, since the T and Poss probes are split, they will always find a way to be valued successfully when probing a coordination.

Of interest, then, is what happens when the conjunctive Gen probe attempts to Agree with a coordination. Let us start with the first configuration, in which local conjuncts are coordinated, e.g., (1+2), and examine agreement with the Gen probe. The crucial aspect of the derivation is that, since both conjuncts contain the interpretable person feature, the Gen head that bears the conjunctive [$u\phi$] probes will be

²⁹Note that a percolation analysis could also work with our system, under the proviso that the probe be capable of keeping track of which feature set belongs to which conjunct. An indexation notation is usually employed to this end in many studies, even those not involving percolation (e.g., Citko 2018; Akkuş 2020; Al Khalaf 2021).

- (64) Coordination of nonlocal + nonlocal conjuncts (e.g., *adam ile Leyla* ‘the man and Leyla’)

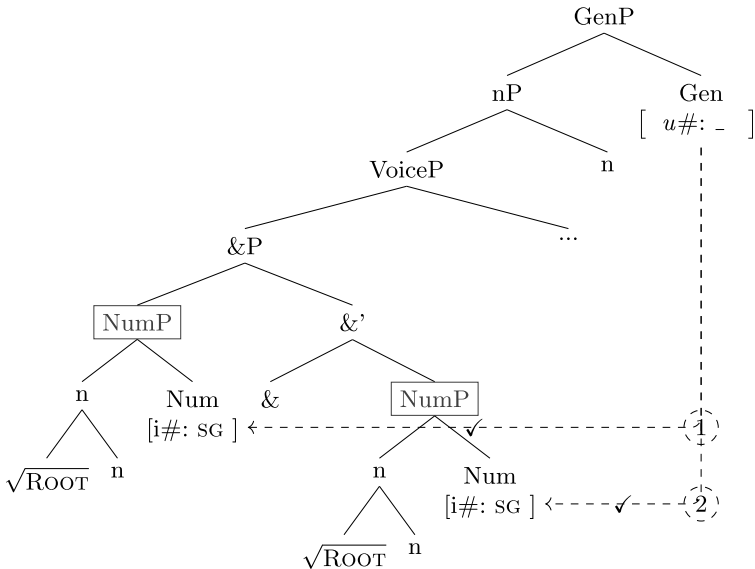

The crucial configurations are those in which a local and a non-local person are conjoined. Recall that in such cases, resolved agreement is disallowed, and default agreement is triggered. Since one of the conjuncts is a DP, the conjunctive $[u\phi]$ probe is inserted (see fn. 24 for the need to license the person feature).³⁰ Even though this probe can be valued by the DP conjunct since it exhaustively finds its match, it fails to be valued by the non-local NumP conjunct since that conjunct possesses a subset of the features that are available on the probe. For this reason, feature resolution fails, and default agreement is inserted.³¹

³⁰This is also in line with and provides further evidence for a type of long-distance selection, which in coordination ignores &P itself and evaluates the conjuncts.

³¹Note that, as also shown in (66) and example (ii) of footnote 32, it is not sufficient for a single conjunct to value the probe. As noted by an anonymous referee, the probe in such instances, as well as any other instances that involve a single probe targeting multiple goals, must be made to interact with all of the available goals, and not just the closest goal, for example. As this issue is part of a larger literature, we do not take a stance as to how this should be modeled exactly. One option is to assume, following Hiraiwa (2001, 2005) (see also Nevins 2011), that the probe has the diacritic $[+multiple]$ in circumstances it needs to search for multiple goals, including coordination. Agreement with multiple conjuncts thus involves a probe specified differently to that involved in the derivation of first- or highest- conjunct agreement, which is orthogonal here; cf. footnote 32.

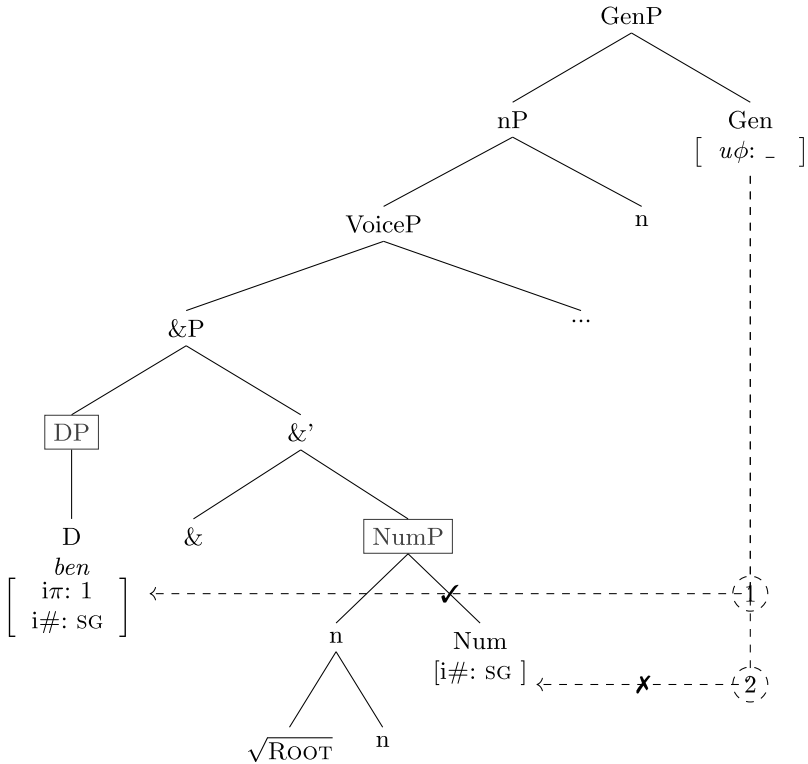
(65) Coordination of local + nonlocal conjuncts (e.g., *ben ile Leyla* ‘I and Leyla’)

Note that the failure of the feature resolution mechanism just mentioned means that the probe should not be able to just realize the features of one conjunct; in other words, in (65), first singular from the first conjunct plus no value from the second conjunct does not resolve to first singular, but rather results in default agreement. Further patterns of *local+nonlocal* coordination demonstrate that this is indeed the case, shedding further light on the inner workings of agreement with coordinations and confirming our assumptions thus far.

For instance, when the local conjunct of a *local+nonlocal* coordination is singular, (66), it still cannot trigger plural agreement on the probe, which would be expected if the whole operation was simply summation of the appropriate features from different conjuncts. This observation further supports the idea that the requirements of the probe need to be independently satisfied for each conjunct; only then can feature resolution take place.

- (66) Herkes [ben ile çocuk-lar-ın piyano-yu beraber
 everyone I and child-PL-GEN piano-ACC together
 { taşı-dığ-ın / ??taşı-dığ-ımız /
 carry-NMLZ-3SG.POSS / carry-NMLZ-1PL.POSS /
 *??taşı-dık-lar-ın }]-1 gör-dü.
 carry-NMLZ-3PL.POSS -ACC see-PST
 ‘Everyone saw that I and the children carried the piano together.’

Another example is provided in (67), in which a first plural pronoun is conjoined with a singular common noun. In this example as well, default agreement is triggered. Realizing the features of only one of the conjuncts, which would yield the first plural form *taşı-dığ-ımız*³² or the third plural *taşı-dık-lar-ın*, is not possible.

- (67) Herkes [biz ile çocuğ-un piyano-yu beraber { taşı-dığ-ın /
 everyone we and child-GEN piano-ACC together carry-NMLZ-3SG.POSS /
 ??taşı-dığ-ımız / *??taşı-dık-lar-ın }]-1 gör-dü.
 carry-NMLZ-1PL.POSS / carry-NMLZ-3PL.POSS -ACC see-PST
 ‘Everyone saw that we and the child carried the piano together.’

2.4 Interim conclusion

In this section, we have introduced the Turkish DTNs and examined their internal structure. We have noted that the emergence of default agreement when these complex pronominals are marked genitive is the result of the interaction of two factors, namely, the way in which person and number features are contributed structurally, and the feature specifications of T and Poss on one hand, and of Gen on the other.

The ingredients we adopt ensure that the system can correctly capture the intricate behavior of the so-called DTNs as opposed to pronouns, as well as leave enough room to understand the inner workings of individual DTNs. The first main component of the analysis just developed concerns how interpretable ϕ features are distributed in pronouns vs larger nominals: whereas interpretable ϕ features are bundled on a single head in simplex pronouns, they are distributed throughout the larger structure in DTNs. Given the presence of Poss as well as Gen in the nominal domain as probes, with the former being the nominal counterpart of T, the second main component

³²Note that in Turkish first conjunct agreement (more precisely, *highest* conjunct agreement, given the word order in Turkish, cf. Al Khalaf 2021, and differing from the first conjunct patterns in head-initial languages, see e.g., Aoun 1999; Munn 1999; van Koppen 2005; Akkuş 2022) is disallowed both in root and nominalized clauses. This shows that there is no agreement with the hierarchically closest conjunct in narrow syntax, and the probe accesses all the goals in its c-command domain.

- (i) *Ben ile Leyla piyano-yu taşı-dı-m.
 I and Leyla piano-ACC carry-PST-1SG
 ‘I and Leyla carried the piano.’
- (ii) *Herkes [ben ile Leyla-nın piyano-yu taşı-dığ-ın]-1 gör-dü.
 everyone I and Leyla-GEN piano-ACC carry-NMLZ-1SG.POSS -ACC see-PST
 ‘Everyone saw that I and Leyla carried the piano.’

relates to the structure of probes: on the T and Poss heads, person and number features probe separately, whereas on the Gen head, the two features form a conjunctive probe. The resulting system guarantees that all probes will be successfully valued by simplex pronouns, yielding co-varying agreement in this case; but the different featural make-up of DTNs leads to a different situation when these interact with the different probes. T and Poss trigger co-varying agreement when they probe DTNs directly; but Poss ends up realizing default agreement when it embeds a Gen head that probes a DTN.

A further subdivision is drawn within Gen itself, which can either host a conjunctive probe (with person and number probing together) or a probe with just the uninterpretable number feature. This divide allows us to capture the complex behavior of coordinate phrases, while maintaining the essence of the overall analysis.

Though the eventual system has a few moving parts, we believe it ultimately offers a parsimonious and, importantly, unified account of an extremely complex set of facts, thereby paving the way for our analysis of the interaction of binding with agreement in Sect. 3.³³

2.5 Brief excursus: Partitives

In the next section, we discuss the connection between binding and agreement. However, before proceeding with that discussion, we briefly note the distinct behavior of “partitives,” which are usually treated on par with other DTNs (see e.g., Ince 2008; Paparounas and Akkuş 2020; Satik 2020). However, a closer investigation reveals that “partitives” exhibit properties that warrant identifying them as a distinct type from the genuine DTNs (multi-plural pronouns, adnominal pronouns and coordinations of local+nonlocal persons).

The crucial observation is that, unlike genuine DTNs, partitives do not exhibit a contrast between verbal and nominalized clauses. In (root or embedded) verbal clauses, partitives trigger co-varying agreement, like DTNs; but, unlike in the case of DTNs, this is not the only option. Default agreement is also allowed (although not as readily). This possibility is shown in (68).

³³Various alternative approaches have been brought to our attention, and as far as we can tell, they do not capture the facts. For example, Rajesh Bhatt (p.c.) suggests that Gen does one cycle of Agree with the topmost node, whereas T can do multiple cycles of Agree. As far as we can tell, this would predict the possibility of person features valued on Gen in the context of multi-plural pronouns and adnominal pronouns. However, this is not allowed in these constructions. Moreover, another statement would need to be made for coordination, since this account as it stands would mispredict the possibility of First Conjoint Agreement (without feature percolation), or full agreement (with feature percolation).

Another option is to make the probe sensitive to whether it is valued on a single cycle of Agree, or multiple cycles, assuming all of the Gen, Poss and T can perform cyclic agree. To be precise, T and Poss would spell out the collected features regardless of whether those features were copied on a single search or multiple searches, whereas Gen would show full agreement only if the features are accessed on a single cycle, but would realize default agreement if the features are transferred on different cycles of Agree. This strikes us as rather stipulative and counterintuitive: encoding sensitivity to a single search vs multiple searches seems non-trivial, and not realizing features that are already on the probe due to their derivational history is a very powerful constraint. Given that alternative hypotheses do not fare well for our data while the approach in the main text gives a coherent analysis of the patterns, we follow the line of inquiry given in the main text.

- (68) İki-miz parti-ye git-ti- { **k** / \emptyset }.
 two-1PL.POSS party-DAT go-PST- 1PL 3SG
 ‘(The?) two of us went to the party.’

In this connection, we have made what we believe is a novel observation for Turkish, namely, that the presence or absence of the co-varying agreement corresponds to a clusivity effect (more precisely, it tracks the inclusion of the *speaker*). In the normal case, an agreeing partitive is interpreted as definite. To see this, consider the following disambiguating context:

- (69) There are four individuals A, B, C and D. A, B and C went to a party, whereas D stayed at home. The following day, we ask what happened. D replies:]
 Üç-ümüz parti-ye git-ti-k, # ama ben ev-de kal-dı-m.
 three-1PL.POSS party-DAT go-PST-1PL but I home-LOC stay-PST-1SG
 ‘The three of us went to the party, but I stayed at home.’

(69) is infelicitous in the context given, just like the English translation. This suggests that the agreeing partitive *üçümüz* is interpreted as speaker-inclusive: it must mean ‘a set of three that includes the speaker,’ as opposed to the weaker interpretation corresponding to English *three of us*.

Intriguingly, however, this is not the only interpretive possibility. Partitives have the additional option of not agreeing with the finite verb, unlike DTNs. Non-agreement has an effect on interpretation; contrast (69) with the following example:

- (70) [There are four individuals A, B, C and D. A, B and C went to a party, whereas D stayed at home. The following day, we ask what happened. D replies:]
 Üç-ümüz parti-ye git-ti- \emptyset , ama ben ev-de kal-dı-m.
 three-1PL.POSS party-DAT go-PST-3SG but I home-LOC stay-PST-1SG
 ‘Three of us went to the party, but I stayed at home.’

In (70), the partitive does not agree with the verb; strikingly, the continuation *but I stayed at home* is now felicitous. In other words, agreeing partitives are interpreted as definite and inclusive, whereas non-agreeing partitives correspond to English *three of us*, which may or may not include the speaker.³⁴

Crucially, clusivity also plays a role in agreement in nominalized clauses. Even though default agreement is the most readily available option, it turns out that once clusivity is taken into consideration, co-varying agreement is also acceptable, and thus parallels the facts in root clauses.³⁵ Consider (71) and (72).

³⁴This discussion also indicates that the claim of Aydın (2008) and Satk (2020) that default agreement is disallowed in root clauses unless the focus particle *sadece* ‘only’ is involved cannot be the correct generalization. It is worth noting that the contexts they provide are also encompassed under clusivity.

³⁵It is intriguing that in root clauses, co-varying agreement is the preferred option, whereas in nominalized clauses, it is default agreement that is preferred.

- (71) Üç-ümüz-ün parti-ye git-tiğ-**in-i** düşün-dü, ama
 three-1PL.POSS-GEN party-DAT go-NMLZ-3SG.POSS-ACC think-PST but
 ben ev-de kal-dı-m.
 I home-LOC stay-PST-1SG
 ‘S/he thought that three of us went to the party, but I stayed at home.’
- (72) Üç-ümüz-ün parti-ye git-tiğ-**imiz-i** düşün-dü, # ama
 three-1PL.POSS-GEN party-DAT go-NMLZ-1PL.POSS-ACC think-PST but
 ben ev-de kal-dı-m.
 I home-LOC stay-PST-1SG
 ‘S/he thought that three of us went to the party, but I stayed at home.’

As such, partitives behave differently from the DTNs, which is observable once the clusivity factor is taken into consideration. Noting this interesting property of partitives whose investigation is being undertaken separately, we move on to the discussion of the second generalization, which examines the connection between binding and agreement.

3 Generalization 2: Binding enables agreement

3.1 Data

As illustrated in the previous section, DTNs in nominalized clauses cannot participate in co-varying agreement. Example (18), repeated here as (73), established this fact for the DTN subject of an intransitive verb like *git-* ‘go’; but nothing changes if the DTN is the subject of a transitive predicate whose internal argument is a common noun (74):³⁶

- (73) Kemal [biz-ler-in oraya git-tiğ- { *imiz / in }]-i
 Kemal we-PL-GEN there go-NMLZ- 1PL.POSS 3SG.POSS -ACC
 san-dı-∅.
 think-PST-3SG
 ‘Kemal thought that we went there.’
- (74) Ali [biz-ler-in **kitab-ı** sev-diğ- { *imiz / in }]-i
 Ali we-PL-GEN book-ACC like-NMLZ- 1PL.POSS 3SG.POSS -ACC
 söyle-di-∅.
 say-PST-3SG
 ‘Ali said that we like the book.’

In (74), the genitive-marked DTN fails to agree with the nominalized verb *sev-* ‘like,’ whose object is the common noun *kitap* ‘book.’ Given the data seen so far, this is expected.

³⁶We illustrate with “factive” nominalized *-DIK* clauses throughout, but the same facts hold for “non-factive” *-mA* clauses, as seen in (76) and (79).

Strikingly, a genitive-marked DTN *can* participate in nominal agreement when it binds an object reciprocal.³⁷

- (75) Ali [biz-ler-in gerçekten **birbir-imiz-i** sev-diğ- {
 Ali we-PL-GEN really each.other-1PL.POSS-ACC like-NMLZ-
imiz / in }]-i söyle-di-∅.
 1PL.POSS 3SG.POSS -ACC say-PST-3SG
 ‘Ali said that we really like each other.’
- (76) Bu iki inanç grub-u-nun [biz-ler-in **birbir-imiz-i**
 this two faith group-CM-GEN we-PL-GEN each.other-1PL.POSS-ACC
 nasıl yanlış anla-ma-**mız**]-a neden ol-duğ-u-nu
 how wrong understand-NMLZ-1PL.POSS -DAT cause be-NMLZ-POSS-ACC
 göster-iyor-∅.
 show-PROG-3SG
 ‘It shows how these two faith groups are causing us to misunderstand each other.’³⁷

The same pattern obtains when the multi-plural pronoun binds an object reflexive³⁸ (77) or a bound pronoun³⁹ (78): whenever a genitive-marked DTN subject binds one of these elements, it can agree.⁴⁰

- (77) Ali [biz-ler-in **kendi-miz-i** sev-diğ- { **imiz / in**
 Ali we-PL-GEN self-1PL.POSS-ACC like-NMLZ- 1PL.POSS 3SG.POSS
 }]-i söyle-di-∅.
 -ACC say-PST-3SG
 ‘Ali said that we like ourselves.’
- (78) Ali [biz-ler-in **tez-ler-imiz-i** bitir-diğ- { **imiz /**
 Ali we-PL-GEN thesis-PL-1PL.POSS-ACC finish-NMLZ- 1PL.POSS
in }]-i söyle-di-∅.
 3SG.POSS -ACC say-PST-3SG
 ‘Ali said that we finished our theses.’

³⁷To reiterate, the discussion in this section is about the variety we labeled Grammar 3 in footnote 5.

³⁷<https://tr-ex.me/translation/turkish-english/yanl%C4%B1%C5%9F+bir+inan%C3%A7#ref>.

³⁸The reflexive can be logophoric, while the reciprocal cannot; see Legate et al. (2020: 779) for data illustrating this contrast and Kornfilt (2001) for more details on the reflexive.

³⁹Thanks to Jaklin Kornfilt for pointing out the bound pronoun facts and providing us with some of the examples in this section.

⁴⁰An anonymous referee brings up the following example to our attention, where an anaphoric possessor in the object DP enables full agreement, paralleling (78). This follows straightforwardly from our analysis as well, as detailed below. Thanks to the referee for the example.

- (i) (?) Ali [biz-ler-in birbir-imiz-in sınav-lar-ı-nı çöz-düğ- { **ümüz /**
 Ali we-PL-GEN each.other-1PL.POSS-GEN exam-PL-POSS-ACC solve-NMLZ- 1PL.POSS
ün }]-ü söyle-di-∅.
 3SG.POSS -ACC say-PST-3SG
 ‘Ali said that we solved each other’s exams.’

(79) is another attested example (also confirmed by our consultants) that illustrates both agreement possibilities under binding. It is a student-club announcement, which has two versions, one with full agreement, and the other with default agreement.⁴¹

- (79) Geleceğ-in bilim insan-lar-ı ol-acak [biz-ler-in
 future-GEN science human-PL-CM be-FNMLZ we-PL-GEN
birbir-imiz-i daha yakından tanı-ma- { **mız** /
 each.other-1PL.POSS-ACC more closely know-NMLZ- 1PL.POSS
sin }]-ı ... sağlı-yor.
 3SG.POSS -ACC ... make.possible-PROG
 ‘It makes it possible for us, the future scientists, to get to know each other
 more closely.’

In summary, in (75)–(79), which only differ from (74) in that the embedded object is anaphoric (and from (73), which lacks an object), co-varying nominal agreement seems to be made possible through binding.

The examples so far show that a genitive-marked multi-plural pronoun triggers co-varying agreement when it binds. The other DTNs obey the same pattern. (80)–(82) illustrate the same generalization for adnominal pronouns.

- (80) Kemal [biz Türk-ler-in oraya git-tiğ- { ***imiz** / **in** }
 Kemal we Turk-PL-GEN there go-NMLZ- 1PL.POSS 3SG.POSS
]-i san-dı-∅.
 -ACC think-PST-3SG
 ‘Kemal thought that we Turks went there.’
- (81) Kemal [biz Türk-ler-in { **birbir-imiz-i** /
 Kemal we Turk-PL-GEN each.other-1PL.POSS-ACC
kendi-miz-i } sev-diğ- { **imiz** / **in** }]-i
 self-1PL.POSS-ACC like-NMLZ- 1PL.POSS 3SG.POSS -ACC
 söyle-di-∅.
 say-PST-3SG
 ‘Kemal said that we Turks like each other/ourselves.’
- (82) Kemal [biz Türk-ler-in piyano-lar-ımız-ı sev-diğ- {
 Kemal we Turk-PL-GEN piano-PL-1PL.POSS-ACC like-NMLZ-
imiz / **in** }]-i söyle-di-∅.
 1PL.POSS 3SG.POSS -ACC say-PST-3SG
 ‘Kemal said that we Turks like our pianos.’

Coordinate pronouns also behave the same. Recall that coordinations of local and non-local persons are part of the DTN category in that while otherwise they trigger co-varying agreement, they result in default agreement in nominal contexts (cf.

⁴¹The links are as follows:

<https://istanbultto.com/wp-content/plugins/flipbook-wordpress-plugin-6/flipbook-plugin/data/files/basic-html/page42.html>.

<http://www.cleanroomnews.org/istanbul-universitesi-genetik-kulubu-kis-okulu>.

Sect. 2.3.5). For Grammar 3 speakers, these coordinate phrases also participate in the binding/agreement interaction: when genitive, they can only control agreement if they bind. This fact is illustrated in (83) for reciprocals, in (84) for reflexives, and in (85) for bound pronouns.

- (83) Kemal [ben ile Leyla-nın birbir-imiz-i
 Kemal I and Leyla-GEN each.other-1PL.POSS-ACC
 taşı-dığ-**ım** / taşı-dığ-**ımız**]-1 gör-dü.
 carry-NMLZ-3SG.POSS carry-NMLZ-1PL.POSS -ACC see-PST
 ‘Kemal saw that I and Leyla carried each other.’
- (84) Kemal [ben ile Leyla-nın kendi-miz-i taşı-dığ-**ım** /
 Kemal I and Leyla-GEN self-1PL.POSS-ACC carry-NMLZ-3SG.POSS
 taşı-dığ-**ımız**]-1 gör-dü.
 carry-NMLZ-1PL.POSS -ACC see-PST
 ‘Kemal saw that I and Leyla carried ourselves.’
- (85) Kemal [ben ile Leyla-nın piyano-lar-ımız-ı
 Kemal I and Leyla-GEN piano-PL-1PL.POSS-ACC
 taşı-dığ-**ım** / taşı-dığ-**ımız**]-1 gör-dü.
 carry-NMLZ-3SG.POSS carry-NMLZ-1PL.POSS -ACC see-PST
 ‘Kemal saw that I and Leyla carried our pianos.’

Importantly, regardless of the agreement indexed on the nominalized verb, the anaphor itself must inflect for the ϕ -features of its antecedent.⁴²

- (86) *Kemal [biz-ler-in gerçekten **birbir-in-i** sev-diğ- {
 Kemal we-PL-GEN really each.other-3SG.POSS-ACC like-NMLZ-
 imiz / in }]-i söyle-di- \emptyset .
 1PL.POSS 3SG.POSS -ACC say-PST-3SG
 ‘Kemal said that we really like each other.’

Crucially, the striking interaction between binding and agreement just discussed is local. This fact is best illustrated with bound pronouns, which, unlike local anaphors, need not have a local antecedent. In (86), the bound pronoun is in the lowest embedded clause, introduced by *read*, while its DTN antecedent is the subject of the higher verb *be happy*. In this situation, where a clause boundary intervenes between the DTN binder and its bindee, the DTN does not trigger co-varying agreement on the first embedded verb.

⁴²Some of our consultants find the version of (86) with third-singular agreement on the verb to be marginally more acceptable than the version with first-plural agreement. We have no explanation for this effect. Importantly, regardless of this effect, our primary consultants judge both versions of (86) as substantially worse than either version of (75).

- (87) Leyla [[bölüm başkanı-nın **tez-ler-imiz-i**
 Leyla department chair-GEN thesis-PL-1PL.POSS-ACC
 oku-duğ-u]-na biz-ler-in mutlu ol-duğ-un /
 read-NMLZ-3SG.POSS -DAT we-PL-GEN happy be-NMLZ-3SG.POSS
 *ol-duğ-umuz]-u söyle-di-∅.
 be-NMLZ-1PL.POSS]-ACC say-PST-3SG
 ‘Leyla said that we_i were happy that the department chair read our_i theses.’

A possibility to examine is whether the contrast can be explained in surface-oriented (perhaps processing-related) terms, for example, by assuming that the presence of full agreement on the verb is facilitated by the presence of the phonology of full agreement on the bound reflexive.⁴³ Having a common noun whose phonology resembles that of full agreement as in (88), allows us to show that it cannot solely be a processing issue (thanks to Yılmaz Köylü for providing the example).

- (88) Ali [biz-ler-in **kımız-ı** ısıt-tığ- { *ımız / in }
 Ali we-PL-GEN horse.milk-ACC heat-NMLZ- 1PL.POSS 3SG.POSS
]-ı söyle-di-∅.
 -ACC say-PST-3SG
 ‘Ali said that we heated up the horse milk.’

Note also that the emergence of co-varying agreement cannot be attributed to linear order either: the phenomenon persists if the bound element is scrambled out of the nominalized clause.

- (89) **Kendi-miz-i** Ali [biz-ler-in *t_i* sev-diğ- { imiz /
 self-1PL.POSS-ACC Ali we-PL-GEN like-NMLZ- 1PL.POSS
 in }]-i söyle-di-∅.
 3SG.POSS -ACC say-PST-3SG
 ‘Ali said that we like ourselves.’

There is thus exactly one situation where a genitive-marked DTN can participate in nominal agreement, namely, when it acts as a local binder. The generalization is then as follows:

- (90) *Generalization 2: Binding enables agreement*
 A GEN-marked DTN can only agree if it locally binds an anaphor or bound pronoun.

(90) suggests an intimate connection between local binding and ϕ -agreement. The observed pattern—that local binding licenses an otherwise impossible agreement possibility—furnishes an intuition that Agree-based accounts of binding should be perfectly poised to capture. If binding involves transmission of ϕ -features, then binding configurations provide an extra set of features that can be targeted for agree-

⁴³Thanks to Deniz Özyıldız, Neşe Demir, and Yılmaz Köylü for separately raising this possibility.

ment.⁴⁴ Sect. 3.2 develops an analysis aiming to capture just this intuition. Section 4 then offers refinements to the empirical picture presented here, and sketches their consequences for the generality of an Agree-based approach to binding.

3.2 Analysis

Our account of the binding/agreement interaction will make use of the following pieces of theoretical technology, the last two of which we have already introduced.

- (91) *Ingredients of an Agree-based theory of binding*
- a. **Minimal pronouns:** Local anaphors and (at least some) bound pronouns are underspecified for ϕ -features (Shiraki 2004; Kratzer 2009).
 - b. **Mediated binding:** Minimal pronouns receive ϕ -features through Agree with a c-commanding functional head (Kratzer 2009).
 - c. **Cyclic Agree:** If a probe cannot be valued by the goal it probes first, it can initiate a second cycle of Agree (Rezac 2003; Béjar and Rezac 2009).
 - d. **Failed Agree:** Unvalued uninterpretable features do not cause a derivation to crash; at PF, the morphology supplies them with a default value (Preminger 2014).

The view of the mechanics of Agree-based binding defined by (91a)–(91d) is one of many possible ones. In fact, the only ingredient typically shared across Agree-based theories of binding is (91a); different theories flank this basic ingredient with different assumptions. For example, Reuland (2011) proposes that a single functional head Agrees both with the minimal pronoun and its antecedent, in contrast to (91c). As for (91b), one theory departing from this assumption is found in Wurmbrand (2017), where binding is implemented as an unmediated DP-DP dependency via Reverse Agree. At the end of this section, we will clarify which of the ingredients in (91) are crucial in accounting for (90), and which are assumed for the sake of concreteness. The Turkish facts speak clearly in favor of the role played by ϕ -Agree in local binding, albeit without necessarily distinguishing between different ϕ -Agree-based theories.

(91a) amounts to the claim that a nominal bearing interpretable ϕ -features need not have these features inherently valued. Kratzer (2009) argues that the syntactic representation of some referentially deficient elements—namely anaphors and (some) bound pronouns—should be understood along these lines. For Kratzer, the structural deficiency of minimal pronouns translates into a semantic deficiency: ϕ -deficient elements are variables bound by the closest binder. Under the theory in Kratzer (2009), this is where (91b) becomes crucial: binders are hosted on functional heads. Kratzer goes on to develop a theory that effectively assimilates the relationship between a variable and a binder to that between a goal and a c-commanding probe, whereby the goal is an argument (cf. Pollard and Sag 1992; Reinhart and Reuland 1993) and

⁴⁴Isabelle Charneval (p.c.) asks whether this pattern is also visible in indexical shift. This possibility cannot be tested, as indexical shift in Turkish only takes place in finite embedded clauses with nominative subjects.

the probe is a functional head that licenses and Agrees with that argument. Broadly speaking, the mechanism that serves to transmit ϕ -features from the probe to the goal in the syntax supplies the conditions for variable binding in the semantics.

As Kratzer points out, two preliminary morphological facts about anaphors suggest that ϕ -features must be somehow implicated in binding. Firstly, anaphors often match the ϕ -features of their antecedents:⁴⁵

(92) Mary likes {her / *my / *your}-self.

Secondly, anaphors often fail to control co-varying agreement, as suggested by the observations subsumed under the *Anaphor Agreement Effect* (Rizzi 1990; Woolford 1999; Tucker 2011; Murugesan 2019). The AAE is naturally predicted given underspecification. If anaphors inherently lack ϕ -features, they should be unable to value agreement probes, yielding either ungrammaticality or a default/“special” form of agreement—both outcomes are indeed attested cross-linguistically (Tucker 2011; Sundaresan 2015). In fact, the view of anaphors as minimal pronouns makes a more specific prediction with respect to the AAE. The AAE should arise whenever a probe attempts to Agree with an anaphor that has not yet received ϕ -features from its antecedent. But if Agree targets an anaphor that has already been bound through ϕ -feature transmission, agreement with the anaphor should be successful, leading to an apparent violation of the AAE. Murugesan (2019, 2022) argues that the latter scenario is indeed the case in AAE-violating configurations.

There is thus some morphological evidence in favor of the underspecification of anaphors, and thus of the relevance of ϕ -features to binding. The Turkish binding/agreement interaction offers one more piece of evidence of this kind, one that is novel and striking; as we will now show, this interaction finds a natural analysis in terms of (91a), in conjunction with the other ingredients in (91). Recall that (91c) and (91d) were already introduced in the analysis of Relativized Case Opacity above.

To see how (91) can derive the fact that the opacity is overridden when a DTN binds, consider the bottom-up derivation of a nominalized embedded clause with an object anaphor. Recall from Sect. 2.1 that these clauses involve a full verbal shell. We take this to consist of a *vP* introducing the root (not shown here) and the internal argument, and a separate projection *VoiceP* hosting the external argument (Kratzer 1996, Pyllkkänen 2008, Legate 2014 *i.a.*). In this case, the internal argument is a ϕ -underspecified anaphor, and the external argument a first-plural DTN. For reasons to be clarified later (see Sect. 3.4), we take a special flavor of Voice to be present in the structure, namely $\text{Voice}_{\text{min(imal)}}$, inspired by the $\text{Voice}_{\text{reflexive}}$ of Ahn (2015) (cf. Labelle 2008; Kratzer 2009). This head is tasked with licensing minimal pronouns via Agree (and possibly concomitant case assignment, which is irrelevant here)—in (93), Voice attempts to do just this, reflecting (91b).

⁴⁵The generality of this fact is in fact an open question; Ahn (2019) shows that, in English, ϕ -mismatches are in fact widely available (see also Preminger 2019 on ϕ -matching without binding). We thus take the Anaphor Agreement Effect, and phenomena like the one that forms the focus of this paper, to constitute stronger evidence in favor of the role of Agree in binding than ϕ -matching. We thank an anonymous reviewer for highlighting this point.

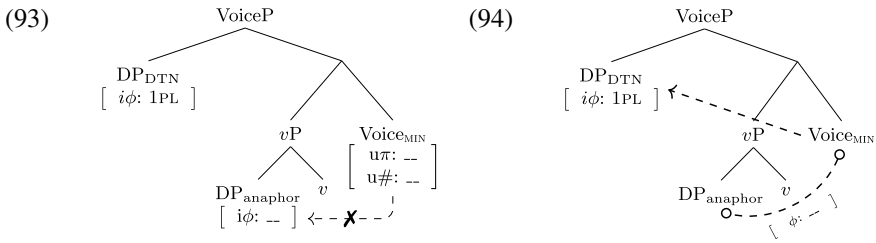

Because the anaphor has no ϕ -features to transmit to the probe, this Agree operation cannot result in valuation. In (94), following Murphy and Meyase (2022), we take this state of affairs to lead to feature-sharing between Voice and the anaphor (Frampton and Gutmann 2000; Pesetsky and Torrego 2007). This feature cannot be valued by downwards Agree, since the probe’s c-command domain contains no further goals. We follow B ejar and Rezac (2009) in assuming that, in just this situation, the probe can search for a goal in its specifier. The specifier of VoiceP is filled by the DTN subject; crucially, the ϕ -features on this nominal are accessible at this point.⁴⁶

In (95) below, the features of the DTN have valued the feature shared between Voice and the minimal pronoun, and percolated to the maximal projection VoiceP. At this point, the higher verbal projections making up the nominalized clause will be merged; since these play no role in the analysis, we have omitted them in the trees. The nominal superstructure of the nominalized clause will be merged next; we take this to consist first of a categorizing head n , where the nominalizing suffixes of Turkish are realized, and Gen, the assigner of genitive Case.⁴⁷

Recall now that, once it has assigned genitive Case, Gen will initiate a first cycle of Agree through its conjunctive probe. We take it that this first cycle of Agree by Gen targets the nominal that Gen has just assigned Case to (similar to instances of possessor agreement, see e.g. Deal 2010 and cf. footnote 58). In the structure we have been building, this nominal is a DTN; thus, by the mechanism described in detail in Sect. 2.3, Agree will fail (95), since the DTN’s distributed ϕ features cannot value Gen’s conjunctive probe. From this point onward, the derivation can proceed in two different ways.

⁴⁶It must be the case that Voice_{MIN} has a split ϕ -probe, and is thereby able to be valued by the DTN. From this perspective, Voice, T and Poss represent the normal case (split probing); the Case-assigning head Gen, having a conjunctive probe, is the “odd one out.”

⁴⁷We take the nominalizing suffixes of Turkish nominalized clauses to be exponents of n , and the nominal agreement suffixes to be realizations of the probe Poss. Recall that, in linear order, the nominalizer is always directly adjacent to and to the left of the agreement suffixes.

(95)

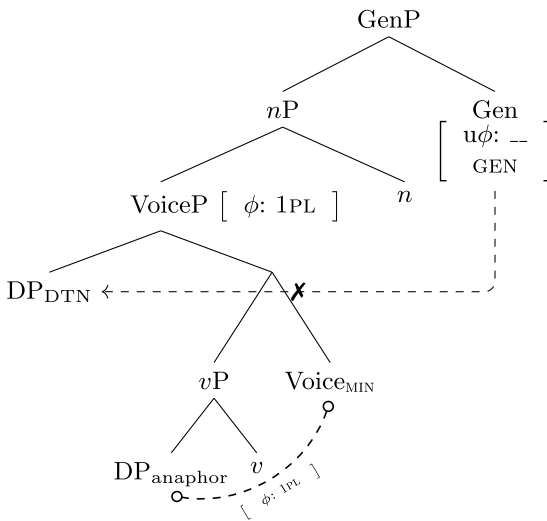

If nothing else happens, once the nominal probe Poss is merged, it will fail to find features on Gen; with the structure below Gen having been spelled out, Poss will not find another suitable goal and will itself remain unvalued, yielding default third-singular values at PF. This situation is schematized in (96) (where we do not illustrate the split probe on Poss as two separate branches, compare (50), simply for space reasons).

(96) Outcome 1: Gen remains unvalued, and Poss too

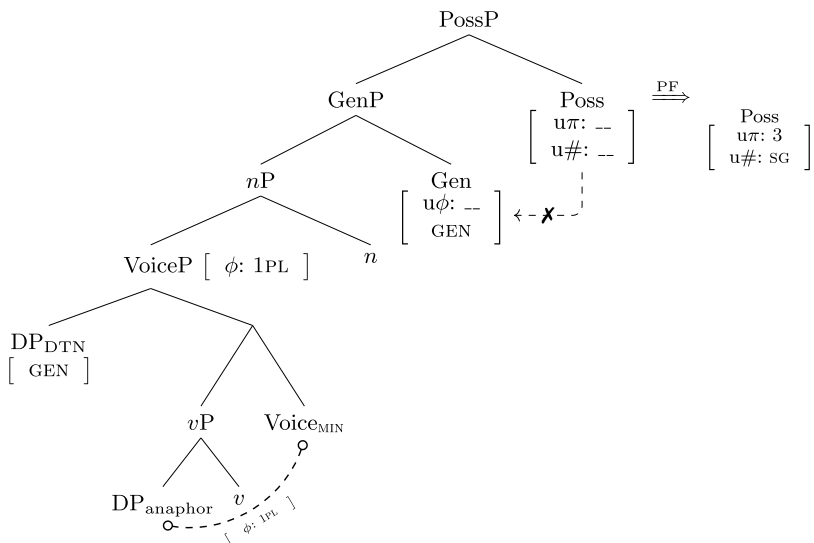

But there is a second possibility: once Gen fails to be valued by the nominal it has assigned Case to, it may initiate a second cycle of Agree, probing the structure again. Crucially, the rest of the structure does provide a second suitable goal, namely,

VoiceP, where the features left after by binding reside. Crucially, the ϕ features on Voice are bundled together (unlike on the DTN), and are thus capable of valuing the conjunctive probe on Gen. With Gen valued, Poss can inherit said values from Gen, yielding co-varying nominal agreement.

(97) Outcome 2: Gen is valued by VoiceP’s features

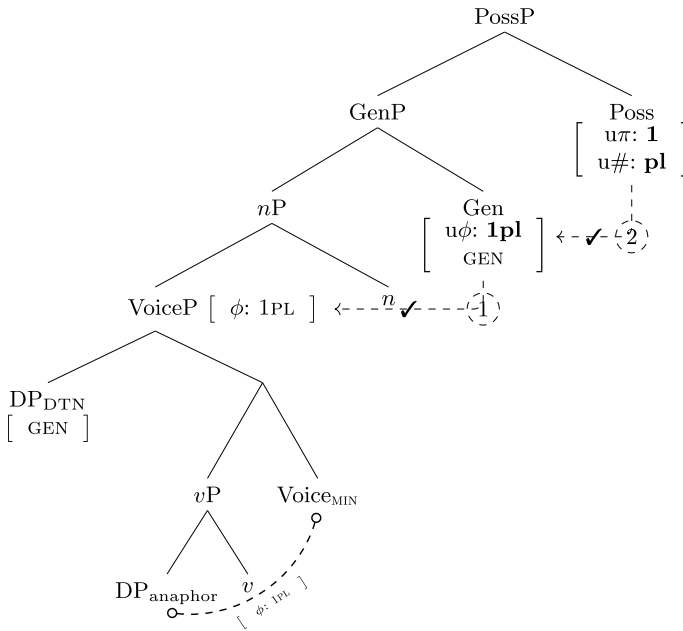

On the whole, then, the effect of binding on the agreement possibilities of nominalized clauses with a DTN subject can be understood as follows. (96) represents the normal case, where a DTN fails to value Gen, resulting in the insertion of default features at PF. But because binding involves transmission of ϕ -features, the relevant structures, where the DTN is a binder, also furnish an additional set of ϕ features on the maximal projection of the mediating head Voice; the second round of Agree initiated by Gen finds these features, resulting in covarying agreement. Because this second cycle of Agree is optional, some derivations will involve just the first cycle of Agree; we thus correctly predict to find optionality between 3SG and 1PL nominal agreement under binding, explaining the full pattern.⁴⁸

⁴⁸ From the perspective of Cyclic Agree, speakers who allow only default agreement even under binding (that is, speakers of *Grammar 2*) have a grammar that has only one cycle of agreement, unlike our primary consultants whose variety we have called *Grammar 3*. This state of affairs is also reminiscent of “Peeking grammar” in Marušić et al. (2015), in which a probe can further target inside a goal after a higher structure. The speakers who only allow default agreement would belong to ‘no peeking grammar,’ though the exact configurations are somewhat different.

Note that the conditions regulating cyclic probing can in principle be cast in the terms of Deal’s (2022) Interaction-Satisfaction model of Agree. In that system, it would need to be the case that for Grammar 2 speakers, the probe is satisfied by the DTN probed first, such that probing halts at this point; while for Grammar 3 speakers, the probe would need to initiate another cycle of Agree to be satisfied.

This analysis has a number of merits. It successfully captures the crucial aspects of the Turkish data outlined in Sect. 3.1. Since the second cycle of Agree, whereby Gen finds the “binding features” on Voice, is optional, co-varying agreement may, but need not, surface when a DTN binds an anaphor locally. Crucially, however, the binding features are present on the feature shared by VoiceP and the anaphor regardless of whether Poss accesses them or not. As such, irrespective of whether the nominal part of the structure manages to reflect full agreement or not, the anaphor will always be bound, and will invariably match the ϕ -features of its antecedent. Under this analysis, the same features will be present on Voice when the subject is a simple pronoun, as opposed to a DTN. But in this case, Gen will never have reason to find them: it will be able to Agree with the pronoun directly, genitive-marked pronouns not being opaque for agreement. As such, the first cycle of probing will always be successful when the subject is a simple pronoun, and the second cycle (the one capable of targeting Voice) will not be initiated.

A further correct prediction of this analysis concerns the order of agreement operations involved here. As discussed above, there is exactly one obligatory cycle of probing, whereby Gen attempts (and fails) to agree with a genitive-marked DTN. The second cycle, where Gen finds the “binding features” on the verbal shell, is optional. This correctly predicts the distribution of grammars we have identified among speakers of Turkish: all speakers allow default agreement with DTNs as binders, and some allow an additional possibility of full agreement (see footnotes 5 and 48). This state of affairs follows from the analysis: if all grammars must involve at least one cycle of probing by Gen, Gen will always first find the element that it has already interacted with for the purposes of Case assignment, namely, the DTN. For speakers who only allow this first cycle of probing, the default agreement with DTNs is not repaired by binding. Speakers who also have the second cycle of probing, whereby Gen finds the ‘binding features,’ show the binding/agreement interaction whereby a genitive DTN agrees only if it binds. But, importantly, no Turkish speaker in our sample allows full agreement in this configuration without also allowing default agreement: the second cycle cannot precede the first.

With these correct predictions in mind, it is important to distinguish between those aspects of the proposed analysis that are indispensable in accounting for the facts, and those which are adopted for concreteness but would leave the spirit of the analysis unaffected were they to be modified.

What is clearly crucial in the analysis advanced above is the transmission of ϕ -features from the external argument to the verbal shell when the verbal shell includes an anaphor. If binding did not involve ϕ -feature transmission in the syntax, there would be nothing to supply the DTN’s features to the nominal agreement probe just when the DTN is a binder. In other words, the central aspect of the above analysis is that binding leaves its signature on the structure, in the form of ϕ -features; these features may subsequently be the target of agreement, explaining why binding gives rise to an otherwise exceptional agreement possibility. The Turkish facts, then, speak in favor of Agree-based accounts that crucially involve ϕ -features (e.g. Kratzer 2009), as opposed to Agree for anaphoric features (e.g. Hicks 2009).

At the same time, certain implementational details are included for concreteness, but could be modified without altering the spirit of the analysis.⁴⁹ In particular, it is not necessary that the step of agreement between the mediating head and the subject be understood specifically in terms of Cyclic Agree. All theories that take the mediating head to c-command the anaphor but not the antecedent require some form of spec-head agreement to transfer the features from the antecedent to the binding head; see e.g. Kratzer's (2009) Predication or Murphy and Meyase's (2022) Valuation under Selection.⁵⁰

The analysis proposed above also raises a number of questions. One of these concerns the nature of the mediating head, taken to be Voice_{MIN} in the illustration above: why is this special flavor of Voice necessary? A further important question concerns binding into positions other than the direct object. We discuss the first of these questions in Sect. 3.4, and the latter in Sect. 4.2. First, however, we turn to one final correct prediction made by the analysis advocated here.

⁴⁹Gary Thoms (p.c.) asks whether an analysis wholly different to that proposed here is admissible, whereby DTNs and simple pronouns occupy different structural positions. This general idea could take a few different forms; in one version of such an analysis, a phase boundary would separate pronouns and DTNs, with pronouns being higher. As such, in the basic cases, pronouns, but not DTNs, would be accessible to a high nominal agreement probe, and DTNs would need to raise out of the lower phase in order to bind an anaphor, thereby also becoming visible to the agreement just when they bind.

Though such an analysis is possible in principle, we see no reason to postulate distinct positions for DTNs and pronouns. In Turkish (and many Turkic languages), distinct structural positions for nominals are normally associated with distinct cases and interpretations. For example, in ECM, the embedded subjects that stay low are nominative/unmarked, while raised subjects receive accusative (e.g. Zidani-Eroğlu 1997; Kornfilt 2007; Şener 2008; Predolac 2017) (see also footnote 7). Similarly, in nominalized clauses, the subject can be nominative if it is low and genitive if it is higher (e.g., Kennelly 1997). In both instances the low position corresponds to *non-presuppositional* readings, whereas the high position leads to *presuppositional*, *topicalized* (or *specific*) interpretations. In fact, the same asymmetry is observed with object positions; caseless, pseudo-incorporated objects remain in the VP domain, whereas specific objects raise to vP and bear accusative case. We observe no Case or interpretation difference of this kind here. It is of course possible in principle to assume that there exist two genitives, one which is assigned only to pronouns in one position, and one which is assigned only to DTNs in a different position. However, there is no evidence for this type of differentiation in the language; we thus believe that the burden of proof rests on the approach postulating two distinct genitives, and not on the simpler option we assume here.

⁵⁰Note, however, that mediating heads do seem necessary in our analysis. An anonymous referee asks whether we could do away with this aspect of the analysis, instead employing a reverse Agree approach of the kind in Wurmbrand (2017): here, minimal pronouns themselves would probe (upwards), while non-minimal pronouns, not having unvalued features, would never probe. The rest of our derivation could remain more or less intact, with the important caveat that, in the second cycle of probing, Poss would find the features on the anaphor itself, not Voice.

We have chosen to forgo an approach of this kind for two reasons. Firstly, the relevant derivation faces issues with cyclicity. Assuming that some low verbal projection (vP or VoiceP) is a phase, Gen should not be able to reach into VoiceP and access the features of the object therein; note that our analysis does not face this issue, since the target of the second cycle of probing is the maximal projection VoiceP, which is by definition on the edge of the relevant phase. Secondly, and more importantly, the reverse Agree account under consideration would in fact not help us make sense of the difference between minimal and non-minimal pronouns discussed in Sect. 3.4: if Gen can probe the object after failing to probe the subject, why do common noun objects not transmit their features to Poss when the subject is a DTN, in the way that anaphors do? In other words, why is (105) below ungrammatical with third plural agreement? In our account, it is Voice_{MIN} that allows us to make the required distinction between structures with and without minimal pronouns: Voice_{MIN} can value the probe on Poss when this head probes for the second time, because Voice_{MIN} (and not other Voice heads) is merged when a minimal pronoun is present in the structure.

3.3 Two ways to dis-Agree in Turkish

All the crucial examples presented so far involve a bound element as the direct object of a nominalized clause, and the examples that follow in Sect. 4.2 show the same elements appearing as indirect objects, applied arguments, and subjects of prepositions. But we may wonder whether bound elements can appear as *subjects* of nominalized clauses, and what agreement possibilities obtain in that case.

To that end, consider the following examples.⁵¹

- (98) Biz [**birbir-imiz-in** sınav-1 geç-tiğ- { ***imiz** /
 we each.other-1PL.POSS-GEN exam-ACC pass-NMLZ- 1PL.POSS
in }]-i san-ıyor-du-k.
 3SG.POSS -ACC believe-PROG-PST-1PL
 ‘We think that each other passed the exam.’
- (99) Biz [**kendi-imiz-in** sınav-1 geç-tiğ- { ***imiz** / **in**
 we self-1PL.POSS-GEN exam-ACC pass-NMLZ- 1PL.POSS 3SG.POSS
 }]-i san-ıyor-du-k.
 -ACC believe-PROG-PST-1PL
 ‘We think that ourselves passed the exam.’

(98)–(99) present two remarkable facts. Firstly, anaphors can occur in the subject position of nominalized clauses without incurring a Condition A violation; and secondly, subject anaphors obligatorily trigger default nominal agreement, thus ostensibly paralleling the distribution of DTNs outlined in Sect. 2.2.⁵²

Let us focus here on the second fact. That subject anaphors are only grammatical with default nominal agreement may, at first glance, suggest that they should be assimilated to the class of DTNs. After all, anaphors are indeed complex pronominal elements in one sense, consisting of a reflexive or reciprocal base (*kendi* and *birbir*, respectively) plus a nominal agreement exponent that co-varies with the features of the antecedent. That anaphors are DTNs is assumed by Paparounas and Akkuş (2020).⁵³

⁵¹(98) and (99) are taken from Kornfilt (2007: 321–322). Kornfilt mentions that the versions of these examples with 3SG agreement are consistently judged as significantly better than the versions with 1PL; however, she also mentions that not all speakers find the 3SG examples perfect in themselves, and marks the 3SG version of (98) with ? and that of (99) with (?). Our consultants unanimously found the versions with 3SG significantly better than those with 1PL; most, but not all, judged the versions with 3SG as perfect.

⁵²Existing work has attempted to draw a direct connection between these two remarkable facts: Kornfilt (2007), building on George and Kornfilt (1981), claims that the anaphors in (98)–(99) pass Condition A because binding domains are defined on the basis of full agreement in Turkish, such that default agreement effectively makes nominalized clauses transparent for binding. See Paparounas and Akkuş (2020) for issues with such an analysis.

⁵³Satık (2020) goes even further, postulating that, exactly like DTNs, anaphors embed a pronoun, albeit one that is null. Satık takes constructions such as *biz kendimiz* ‘we ourselves’ to support such a conclusion. But the picture seems to be more complicated, at least for the reciprocal, which cannot be used with an overt pronoun, unlike the reflexive. Moreover, it is not clear why anaphors would ever display Condition A effects, if they were always locally bound by a (possibly null) pronoun. The relevance of *biz kendimiz* also seems unclear: the anaphor here is an anti-assistive modifier or an identity modifier (Spathas et al. 2015) parallel to English *We built the house ourselves* or *The president himself was at the reception*. In both

But closer inspection suggests that this conclusion cannot be correct. Unlike DTNs, anaphors fail to trigger co-varying agreement in the verbal domain.

- (100) Biz [birbir-imiz çok hasta-(*yız) diye] düşün-dü-k.
 we each.other-1PL.POSS very sick-1PL COMP think-PST-1PL
 ‘We thought that each other was very sick.’

(100) suggests that the lack of co-varying agreement in (98)–(99) cannot be attributed to relativized Case Opacity, since anaphors fail to Agree also when nominative. In other words, anaphors fail to trigger co-varying agreement across the board. We must therefore be dealing with a case of the Anaphor Agreement Effect.⁵⁴

A further difference between anaphors and DTNs is that, while the latter participate in the binding/agreement interaction, the former do not:

- (101) Biz [kendi-miz-in kendi-miz-i (bile) aş-tığ- {
 we self-1PL.POSS-GEN self-1PL.POSS-ACC even outdo-NMLZ
 ??ımız / in }]-i san-dı-k.
 1PL.POSS 3SG.POSS -ACC think-PST-1PL
 ‘We consider ourselves to have outdone (even) ourselves.’ (lit. ‘We think that ourselves outdid (even) ourselves’)

In (101), the object anaphor in the embedded nominalized clause is bound by another anaphor in subject position. Recall that this is the exact configuration where a genitive-marked DTN was grammatical with co-varying agreement on the nominalized verb. Crucially, this is not the case in (101): the subject anaphor continues to only trigger default agreement when it binds.

(101) is of great significance to this discussion, because this example corroborates the timing-based analysis of the binding/agreement interaction offered immediately above. To see why, consider the stage in the derivation of (101) where the feature shared by Voice and the object anaphor probes the specifier of Voice, shown in (102):

cases, the anaphor’s semantic contribution is distinct from its usual reflexivizing function. More widely, there is no reason to conclude from the fact that a pronoun can *sometimes* introduce anaphors that the pronoun *always* does so. A similar effect is observed in relation to adnominal pronouns: when a nominal like *Turks* is introduced by a pronoun like *we*, this yields an adnominal pronoun which triggers covarying agreement; but *Turks* on its own cannot trigger 1PL agreement. Differences like this may indicate that we are dealing with a different structure when the pronoun is overt compared to when it is null, a conclusion already substantiated for the ‘partitives’ discussed in Sect. 2.4. We leave it for future work to identify with more precision the role of the overtiness of the pronoun, noting that the possibility of patterns of differential intervention depending on whether the pronoun is overt or not seem relevant for such a study (cf. Charnavel and Bryant 2023).

⁵⁴Of course, unlike DTNs, anaphors cannot occur as subjects of matrix clauses, regardless of the agreement on the predicate.

- (i) *Birbir-imiz çok hasta-(yız).
 each.other-1PL.POSS very sick-1PL
 ‘Each other are very sick.’

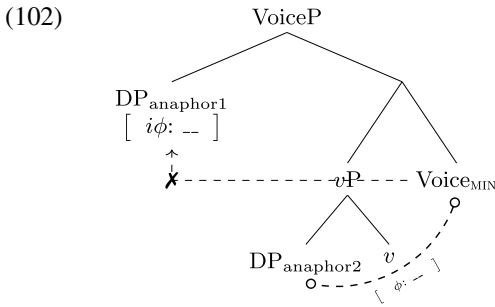

In (94) above, where the external argument was a DTN, spec-head agreement resulted in successful valuation, and it was the features thus acquired by Voice that could subsequently be targeted by Gen. But in (102), the subject, being an anaphor, is ϕ -defective, and is thus unable to value the shared feature. That spec-head agreement fails in this case has important downstream consequences: by the time the nominal probe Gen is merged, there will be no features at all for it to Agree with.

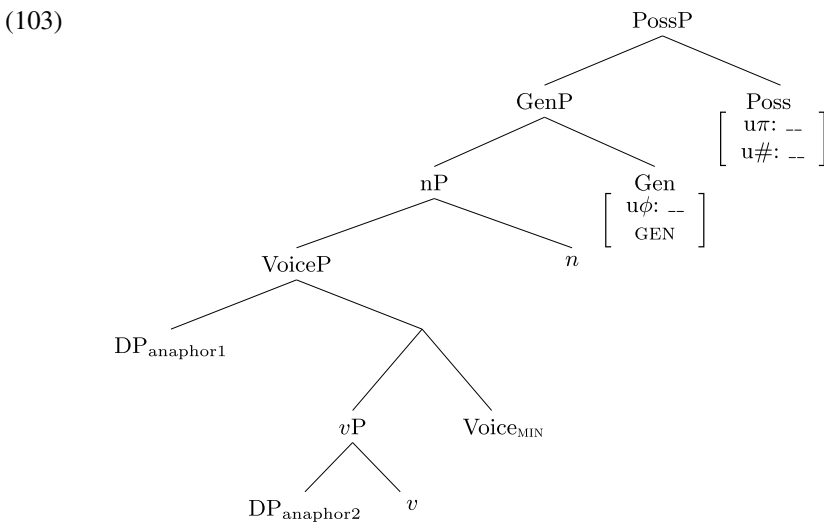

In (103), Gen cannot be valued by the subject directly, because the subject is an anaphor that has not been bound yet; and it cannot be valued by anything below the subject, because no ϕ -features have been exchanged lower in the structure either, as shown in (102). Given the assumption that failed valuation results in feature sharing, a single unvalued ϕ -feature will be shared between the object anaphor, Voice, and the subject anaphor; this feature will eventually be valued by the higher anaphor's antecedent once the lower portion of the matrix clause is merged. Crucially, this step of binding by a matrix argument will take place well after the step of probing by the embedded Gen/Poss. In other words, ϕ -features will make their way to the structure in (103) too late for the embedded probe to be able to probe them, and the embedded

Gen (and Poss) thus remain unvalued.⁵⁵ As such, (101) is only grammatical with default agreement, even though both anaphors eventually bear the ϕ features of the matrix antecedent *we*.

(101) is important, then, in that it corroborates the assumptions made thus far on the relative timing of binding and nominal probing. In the analysis above, we argued that the binding/agreement interaction arises because binding precedes nominal agreement, such that the latter can access the ϕ -features left in the structure by the former. (101) confirms a crucial prediction made by this account: if binding *follows* nominal agreement, the binding/agreement interaction does not occur.⁵⁶

But (101) is important for a further reason. Under the analysis of this example illustrated in (102)–(103), this sentence involves two instances of failed Agree with anaphors; but, as shown by (100), Agree fails for subtly different reasons in each case. In both cases of non-agreement in (101), the probe ends up unvalued; but in one case, this occurs because the anaphoric goal lacks ϕ -features to begin with, while in the other case, the DTN goal does possess ϕ features, albeit in the wrong configuration for the conjunctive probe, as detailed in Sect. 2.3.

It thus seems that anaphors and DTNs fail to control agreement for different reasons: the former because they lack ϕ -features altogether (deriving the AAE), the latter because of the inability of the conjunctive probe on the nominal head Gen to be valued by the distributed- ϕ features of DTNs. In other words, there are two distinct paths to non-agreement in Turkish: the Anaphor Agreement Effect is to be distinguished from (Relativized) Case Opacity (cf. in this respect Preminger 2019; Rudnev 2020; Yuan 2023).

3.4 On binding by Voice

The analysis of the binding/agreement interaction developed above was illustrated with the case of an object reflexive, whose binding by a c-commanding antecedent was mediated by a dedicated Voice head which we labeled Voice_{MIN(IMAL)}, inspired by Labelle (2008), Ahn (2015) (cf. Kratzer 2009). The name we give to this head is purposefully general, given that the role it plays syntactically is not confined to reflexives: what we call Voice_{MIN} is the Voice head that mediates binding relations effected through Agree, and these binding relations involve not only reflexives but also reciprocals and bound pronouns. We assume that Voice_{MIN} enters structures that involve minimal pronouns in order to license them.

There are empirical reasons to employ a dedicated binding head of this kind here: put simply, the binding-agreement interaction, where the nominal probe Poss finds ϕ features that have ended up on Voice, obtains only when the object is anaphoric.

To appreciate the importance of this fact, consider the outcome predicted by a system not employing a dedicated binding head, that is, a system where Voice always

⁵⁵This analysis presupposes a ban on countercyclic probing.

⁵⁶Byron Ahn (p.c.) asks whether the analysis presented in the last section must make use of minimal pronouns, or whether we could take anaphors to be fully specified for ϕ -features. The facts discussed in this section speak against the second option: if anaphors were fully specified, (101) should be grammatical with full agreement, contrary to fact.

initiates ϕ -Agree with the object. To that end, consider the derivation in such a system of a verbal shell with a DTN external argument and a common (non-anaphoric) object:

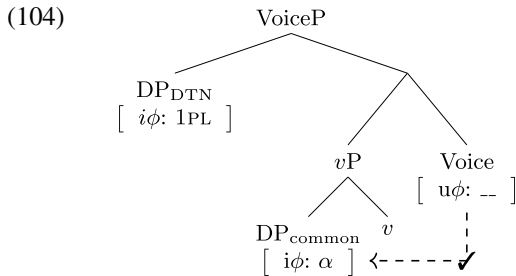

Here, the object's ϕ -features will value Voice; if the rest of the derivation proceeds as discussed above, Poss will have the option of accessing these features on Voice once agreement with the genitive-marked DTN fails. This analysis would therefore predict agreement with the object's features to be possible whenever the subject is a DTN. But this prediction is incorrect:

- (105) Ali [biz-ler-in **kitap-lar-ı** sev-diğ- { in / *lerin }
 Ali we-PL-GEN book-PL-ACC like-NMLZ- 3SG.POSS 3PL.POSS
]-i söyle-di-∅.
 -ACC say-PST-3SG
 'Ali said that we like the books.'

As such, for the system outlined above to not overgenerate, it must be the case that the Agree dependency between Voice and the object is established just when the object is a minimal pronoun. In our view, this is precisely what the Voice_{MIN} head ensures.

This aspect of our analysis—that a special “binding head” in the functional region is needed—is shared by other Agree-based theories of binding. For example, in Kratzer (2009), the rules that ensure that ϕ features are passed on from a functional head's specifier to the head itself, and then further to a minimal pronoun entering a dependency with that functional head, are explicitly relativized to apply to functional heads that bear lambda binders: “the mechanics of feature transmission distinguish heads that bind from those that do not” (Kratzer 2009: 197). Although Kratzer (2009) does not elaborate further on this restriction, it effectively amounts to positing binding heads that enter the structure just when a minimal pronoun must be licensed.⁵⁷ This type of restriction is implicitly assumed in much later work, and is sometimes made explicit (e.g. in the form of the ρ diacritic in Antonenko 2011, or in the feature-sharing condition of Murphy and Meyase 2022: 15).

Recall now that the binding/agreement interaction obtains not just with object anaphors, but also with bound pronouns embedded within the object DP (e.g. *our theses* in (78)), as well as possessor anaphors (see footnote 40). This suggests that

⁵⁷From this perspective, the Reflexive Voice head in Ahn (2015) can be treated as an implementation of the availability of binding heads and is compatible with the system in Kratzer (2009); note that this is not the direction taken in Ahn (2015), however.

the binding head, i.e. our Voice_{MIN}, searches for and licenses minimal pronouns in its c-command domain; the minimal pronoun may thus be the object DP (as in the anaphoric cases discussed above) or a DP embedded within it, as in the case of bound pronouns.^{58,59} Importantly, however, phase locality constrains the depth of this search: as shown by (87), Voice_{MIN} cannot license a minimal pronoun located across a clause boundary.⁶⁰

4 General discussion: The role of Agree in binding

As noted throughout this paper, the Turkish binding/agreement interaction is illuminating with respect to the role of Agree in binding. That co-varying agreement with

⁵⁸See Deal (2010: 99) for a case of external possession similar, at least on the surface, to the situation of binding into a DP embedded in the object position: when certain possessors are externalized in Nez Perce, the movement probe must be able to target a possessor inside the DP, rather than the DP itself. From a technical perspective, the case described in the main text seems easier to implement than the case of external possession, in that the “exceptionally targeted” possessors form a natural class with other elements targeted by the same agreement probe (Voice_{MINIMAL}); this class is made up entirely of minimal pronouns.

⁵⁹Anaphors in Turkish are not subject-oriented (Legate et al. 2020). Given this background, an anonymous referee raises an important question, and provides the following two examples: what happens when an object anaphor is bound by an IO with respect to agreement?

- (i) Herkes [siz-ler-in biz Türkler-e kitab-ı dün göster-diğ-in /
everyone we-PL-GEN we Turks-DAT book-ACC yesterday show-NMLZ-POSS /
*göster-diğ-iniz]-i söyle-di.
show-NMLZ-2PL.POSS -ACC say-PST-3SG
'Everyone said that y'all showed us Turks the book yesterday.'
- (ii) Herkes [siz-ler-in biz Türkler-e birbirimiz-i dün göster-diğ-in /
everyone we-PL-GEN we Turks-DAT each.other-ACC yesterday show-NMLZ-POSS /
*göster-diğ-iniz]-i söyle-di.
show-NMLZ-2PL.POSS -ACC say-PST-3SG
'Everyone said that y'all showed us Turks each other yesterday.'

These examples show that having a local bindee bound by the IO does not result in full agreement with the DTN's features. Assuming IOs to be low applicatives and binding to be facilitated by the Appl head this time, this shows that not any bindee can license subject agreement; only those that are in a local relation with the Voice_{minimal} head can. This follows readily from the analysis in this section.

⁶⁰In Ahn (2015), Reflexive Voice in English triggers movement of anaphors to its specifier, which accounts for the special prosodic behavior of English anaphors (*Bill hates MARY* versus *Bill HATES himself*). It is worth noting that there is no reason to think that this type of anaphor-specific movement is at play in Turkish (thanks to Byron Ahn, p.c., for discussion on this point). One piece of evidence for object movement in Turkish (e.g., Öztürk 2005), or Turkic in general (see e.g., Baker and Vinokurova 2010 for Sakha), comes from the positioning of the object relative to VP-edge manner adverbs. Definite (case-marked) objects precede manner adverbs, whereas non-specific (pseudo-incorporated) objects follow them. This is usually taken to mean that definite objects move outside the VP domain. Crucially, this movement (sometimes also referred to as DOM) applies to both anaphoric and non-anaphoric objects. If one were to extend the entirety of Ahn's proposal to Turkish, we would need to assume a further step of covert movement for anaphoric objects. This, however, is a bit hard to come by, since to our knowledge, anaphoric and non-anaphoric objects have similar prosodic behavior in Turkish (thanks to Aslı Göksel and Beste Kamali, p.c., for discussion of prosody in Turkish).

DTN subjects is only possible when these subjects are binders is natural if ϕ -features are crucially implicated in binding, and mysterious otherwise.

This result then suggests that Agree *can* be implicated in binding; but it would be wrong to conclude on the basis of the discussion so far that all binding *must* involve Agree. In other words, an important question now arises: what is the scope of Agree-based explanations of binding? This section is dedicated to exploring this question against the background of the Turkish binding/agreement interaction.

We begin by providing a brief overview of the available evidence in favor of the role of Agree in binding, placing the binding/agreement interaction investigated here within a broader context. Then, as a final case study, we will argue that data from binding into PPs enables a preliminary view of the limits of Agree-based binding, one whereby only arguments may be bound via Agree.

4.1 ϕ -Features and binding

Four types of evidence suggest that ϕ -features can be implicated in binding:

- (106) *Empirical arguments on binding as Agree*
- a. ϕ -matching between anaphors and antecedents
 - b. The Anaphor Agreement Effect
 - c. Phenomena where bound variable interpretations arise only under co-varying agreement (German, Kratzer 2009)
 - d. Phenomena where agreement emerges only under binding (Turkish, this paper; Tenyidie, Murphy and Meyase 2022)

(106a) and (106b) have already been discussed in Sect. 3.2 (n.b. footnote 45 and Sect. 3.3).

The German case in (106c) is used to argue in favor of the need for functional heads to mediate binding in Kratzer (2009). Kratzer notes that the availability of bound variable readings for first- and second-person embedded possessive pronouns in German is contingent on whether the pronoun and the embedded verb are compatible for ϕ -features. On the account in Kratzer (2009), fake indexicals are minimal pronouns participating in Agree with the functional head that ends up binding them, while referential pronouns are merged with their own ϕ -features, such that they are not bound by a functional head.

While certainly suggestive, the alleged link between syncretism and the availability of bound variable readings has been disputed. Wurmbrand (2017) examines a parallel case where syncretism does not license fake indexicals, and argues that word order, rather than ϕ -feature compatibility, is the factor determining the availability of bound pronoun readings in German. Since we cannot delve further into the issue here, we consider the status of evidence of the type in (106c) open.

Perhaps the strongest evidence in favor of binding-as-Agree comes from phenomena like (106c). If binding and transmission of ϕ -features can be one and the same, we expect to find cases where binding yields new agreement possibilities. Besides the Turkish phenomenon at the heart of this paper, there is one more case of this kind discussed in the recent literature that we are aware of.

Murphy and Meyase (2022) present an intriguing set of binding data from Tenyidie (Sino-Tibetan). Verbal morphology in this language does not normally cross-reference arguments, either subjects or objects as in (107a)—*unless* the verb introduces an object anaphor, in which case what looks like object agreement appears (107b).

- (107) a. á Kēví (*ā-)tshē bā
 1SG Kevi 1SG-praise PROG
 ‘I am praising Kevi’
- b. á ā-thuó *(ā-)tshē bā
 1SG 1SG-self 1SG-praise PROG
 ‘I am praising myself’ (Murphy and Meyase 2022: 4)

Murphy and Meyase argue that this striking pattern can be understood if binding of Tenyidie object anaphors requires an Agree relation between the anaphor and the head that licenses objects. Under their analysis, the “object marker” is actually the morphological realization of binding, explaining why it only surfaces with anaphoric objects.

The facts discussed in Murphy and Meyase (2022) thus complement the phenomenon addressed in this paper nicely. The results converge empirically: in Tenyidie, objects are only agreed with if they are bound, while in Turkish, certain subjects only agree if they bind. And the analyses of these facts also converge: under both analyses, what looks like agreement with an anaphor actually reflects the structural imprint on binding on a functional projection.

If binding can readily involve Agree, we may wonder why patterns like those in Turkish and Tenyidie are not more pervasive. One answer may be that diagnosing the link between binding and agreement requires a very precise set of circumstances. In both Turkish and Tenyidie, some agreement configuration is normally impossible (either due to Case Opacity, or because the language does not index agreement generally); additionally, this configuration is one where bound elements can appear. It could be that such circumstances are rare; but it is equally likely that they have not been actively sought for. Whether binding repairs configurations of non-agreement more widely is an important question for future research to elucidate.⁶¹

It is thus possible to adduce empirical evidence in favor of Agree-based binding; this makes the need to consider arguments against it all the more pressing. It is to such arguments that we now turn. Since it is impossible to offer a comprehensive discussion of possible issues faced by Agree-based accounts here, we focus on one specific issue, namely the problem of binding into PPs.

⁶¹Investigating this question will clearly involve grappling with the specifics of binding and agreement in each language. For example, an anonymous referee points out that, in Japanese, which lacks (overt) ϕ -agreement across the board, save for the honorific system, agreement also does not emerge under binding. One may then wonder what the difference is between non-agreeing languages that show agreement only under binding—like Tenyidie—and non-agreeing languages that continue not to show agreement, *even* under binding—like Japanese. What this parameterization may follow from is a question best left to detailed studies of the languages in question.

4.2 Arguments and PPs

We now consider a well-known empirical concern surrounding binding-as-Agree, raised most recently in Safir (2014) and Bruening (2021): binding of anaphors embedded within PPs is generally unproblematic, but PPs often behave as opaque domains for the purposes of agreement (Rezac 2008). We will present preliminary evidence suggesting that this asymmetry between binding and agreement is approximately correct for Turkish, with one important modification: argument PPs behave differently from adjunct PPs with respect to the binding/agreement interaction. This asymmetry will lead us to speculate that the involvement of Agree in binding is limited along the lines of the argument/adjunct distinction: only arguments may be bound via Agree.

In Sect. 3, it was shown that the binding/agreement interaction in Turkish occurs when a DTN subject is the antecedent of a bound element in direct object position. The same phenomenon obtains with bound elements in other object positions. Anaphors also license co-varying nominal agreement when they are the indirect object of a nominalized clause.⁶²

- (108) Öğretmen [biz-ler-in birbir-imiz-e hediye al-dığ- {
 teacher we-PL-GEN each.other-1PL.POSS-DAT gift buy-NMLZ-
imiz / **in** }]-a inan-ma-dı-Ø.
 1PL.POSS 3SG.POSS -DAT believe-NEG-PST-3SG
 ‘The teacher didn’t believe that we bought presents for each other.’

Against this background, we can turn to anaphors in prepositional phrases. Consider firstly prepositional benefactives.

- (109) Öğretmen [biz-ler-in birbir-imiz için dans et-tiğ- {
 teacher we-PL-GEN each.other-1PL.POSS for dance do-NMLZ-
imiz / **in** }]-e inan-ma-dı-Ø.
 1PL.POSS 3SG.POSS -DAT believe-NEG-PST-3SG
 ‘The teacher didn’t believe that we danced for each other.’

⁶²The effect persists with anaphors as applied arguments more generally; the following example illustrates with the applied argument of a dynamic unaccusative:

- (i) Öğretmen [kura-da biz-ler-in birbir-imiz-e çık-tığ- { **imiz** /
 teacher draw-LOC we-PL-GEN each.other-1PL.POSS-DAT emerge-NMLZ- 1PL.POSS
in }]-i söyle-di-Ø.
 3SG.POSS -ACC say-PST-3SG
 ‘The teacher said that the two of us matched with each other (lit. emerged say to each other) in the draw.’

These examples can be accommodated under the analysis of the binding/agreement interaction offered in Sect. 3.2. As long as the applied argument anaphor occupies a position below the external argument, it should be visible for probing by the binding-mediating head. Note that the necessity of accommodating these examples furnishes a further argument against tying binding to object licensing: under the analysis advanced here, (expletive) Voice in Turkish (Key 2021) will bind the applied arguments in (108) and (i), even though an Agree relation between Voice and these arguments presumably does not hold when these are not anaphoric.

In (109), the anaphor is the complement of the benefactive PP. Not only does the anaphor pass Condition A, but its presence also yields the binding/agreement interaction: co-varying agreement is grammatical here. In this respect, prepositional benefactives pattern with dative benefactives, which also license co-varying nominal agreement when anaphoric:⁶³

- (110) Öğretmen [biz-ler-in birbir-imiz-e dans et-tiğ- {
 teacher we-PL-GEN each.other-1PL.POSS-DAT dance do-NMLZ-
imiz / in }]-e inan-ma-dı-Ø.
 1PL.POSS 3SG.POSS -DAT believe-NEG-PST-3SG
 ‘The teacher didn’t believe that we danced for each other.’

When we turn from benefactives to less argumental PPs, an intriguing pattern emerges: for our primary consultants, anaphors in adjunct PPs continue to be bound, but without licensing co-varying agreement on the nominalized verb. Consider first temporal locatives:

- (111) Herkes [biz-ler-in birbir-imiz-in doğum günün-de
 everyone we-PL-GEN each.other-1PL.POSS-GEN birth day-LOC
 sürekli parti ver-diğ- { ??imiz / in }]-i
 always party throw-NMLZ- 1PL.POSS 3SG.POSS -ACC
 düşün-üyor-Ø.
 think-PROG-3SG
 ‘Everyone thinks that we always throw parties on each other’s birthdays.’

The temporal locative PP in (111) contains a reciprocal; since the sentence can be grammatical, the reciprocal must be locally bound. Crucially, however, the sentence is only grammatical with default third-singular agreement. In this case, local binding of the anaphor has not made co-varying agreement possible.

The same effect obtains with spatial locatives and *because*-PPs, respectively, as shown in the following examples:

⁶³An interesting question concerns whether we can identify structural differences between adpositional and dative benefactives. We cannot devote much space to this question, but it is worth noting that some standard diagnostics do not carry over to Turkish. For example, one may wonder whether Turkish may show contrasts corresponding to the English PP/applied argument asymmetry diagnosed via clefting:

- (i) a. It was for John that I baked a cake. (cf. *I baked a cake for John*)
 b. *It was John that I baked a cake. (cf. *I baked John a cake*)

Akkuş (2021) demonstrates that cleft constructions in Turkish allow argument pivots, but not adjunct pivots. However, as a category, PPs in general cannot be clefted in Turkish, cutting across the argument/adjunct distinction. Therefore, this cannot be employed in this case.

- (112) Herkes [biz-ler-in birbir-imiz-in ev-in-de
 everyone we-PL-GEN each.other-1PL.POSS-GEN house-3SG.POSS-LOC
 sürekli parti ver-diğ- { **??imiz / in** }]-i
 always party throw-NMLZ- 1PL.POSS 3SG.POSS -ACC
 düşün-üyor-Ø.
 think-PROG-3SG
 ‘Everyone thinks that we always throw parties at each other’s houses.’
- (113) Herkes birbir-imiz yüzünden [biz-ler-in sınıf-ta
 everyone each.other-1PL.POSS because we-PL-GEN class-LOC
 kal-diğ- { ***/??imiz / in** }]-i düşün-üyor-Ø.
 flunk-NMLZ- 1PL.POSS 3SG.POSS -ACC think-PROG-3SG
 ‘Everyone thinks that we flunked the class because of each other.’

If we take the binding/agreement interaction as a diagnostic for the involvement of Agree in binding, we can conclude from the above examples that not all local binding involves ϕ -feature transmission. Instead, to a first approximation, an argument/adjunct asymmetry seems to be at play: anaphors enable co-varying nominal agreement when in a low argument position (internal argument, recipient/applied argument, benefactive), but not when merged in more peripheral positions.

If only arguments can be bound via Agree, then there must exist a separate means of binding that takes place in examples such as (113). This possibility would bring anaphors in line with bound pronouns, which seem to be able to be bound in two ways, either by syntactic binding proper or by simple c-command at LF. That a mechanism of the latter kind is independently needed is shown by (87), repeated here, where a bound pronoun is bound across a clause boundary without triggering co-varying agreement. The anaphor in (113) may thus be bound in the same way as the pronoun in (87), repeated here as (114).

- (114) Leyla [[bölüm başkanı-nın **tez-ler-imiz-i**
 Leyla department chair-GEN thesis-PL-1PL.POSS-ACC
 oku-duğ-u]-na biz-ler-in mutlu ol-duğ-u /
 read-NMLZ-3SG.POSS -DAT we-PL-GEN happy be-NMLZ-3SG.POSS
 *ol-duğ-**umuz**]-u söyle-di-Ø.
 be-NMLZ-1PL.POSS]-ACC say-PST-3SG
 ‘Leyla said that we were happy that the department chair read our theses.’

The idea that arguments and non-arguments are bound by different means establishes a link between the Agree-oriented discussion pursued here and coargumenthood-based theories of binding (Pollard and Sag 1992; Reinhart and Reuland 1993; see also Reuland 2011: Ch. 6). These theories attempt to connect the binding-related behavior of anaphors to the relationship they hold with the predicate that introduces them and other arguments of that predicate. These theories embody the intuition that, if a predicate has an anaphoric argument, the antecedent of this anaphor must also be an argument of this predicate; furthermore, if the predicate lacks another argument to bind the anaphor, then the anaphor is exempt from Condition A (see Charnavel and Sportiche 2016: 48ff. for overview and criticisms). This requirement is meant to explain contrasts like (115); we see the same effect with *by*-phrases (116):

- (115) a. Max boasted that the queen invited Lucie and himself for a drink.
 b. *Max boasted that the queen invited himself for a drink. (Reinhart and Reuland 1993: 670)
- (116) a. Tom believed that the paper had been written by Ann and himself.
 b. *Tom believed that the paper had been written by himself.
 (Ross 1970: 227, cited in Charnavel 2019: 9)

In the (a) examples, the anaphor forms part of a coordinate phrase argument, rather than itself being the argument; it thus need not be bound by a coargument, and can be bound long-distance. In the (b) examples, long-distance binding is meant to be ruled out precisely because the anaphor is an argument not bound by its coargument.

Coargumenthood theories converge with the discussion in this section insofar as they posit that argument and non-argument anaphors differ with respect to their binding properties. But the assumptions underlying this paper and those of coargumenthood theories differ in key respects. The main divergence concerns the fact that it is unclear what constitutes a “coargument” if, as assumed here, argument relations are delexicalized. If different arguments are introduced by distinct functional heads, there is no structural counterpart to the more traditional conception of a single predicate introducing multiple arguments.

We may then ask how Agree-based theories of binding may offer a (partial) structural recasting of the intuition underlying coargumenthood-based theories of binding without assuming a monolithic conception of the notion “argument.” Two possibilities come to mind.

Under one possibility, the crucial factor governing the distribution concerns the fact that nominals typically classed as arguments are generally merged low, below the head mediating binding. In this view, what ensures that benefactive PPs participate in the binding/agreement interaction (109), while locative PPs do not (112), is that the latter are too high to be seen by the mediating head Voice. Even if locatives are adjoined to VoiceP, thereby modifying the event, they will still not be c-commanded by Voice (*modulo* reflexive c-command).

A second line of explanation would capitalize on possible phrase-structural differences between adjunct and non-adjunct nominals. In much work following Lebeau (1991), adjuncts are taken to be merged late. This approach makes clear predictions with respect to the behavior of adjuncts relative to other operations: if adjuncts enter the derivation too late to participate in Agree, we may fully expect them not to show the morphological signature of Agree that we observe for Turkish arguments, namely, the emergence of co-varying agreement under binding by a DTN.

Both lines of explanation seem in principle admissible to us, and we leave the choice between the two open here since we lack the space to do justice to the details that each must confront. For example, the first explanation, capitalizing on the notion of structural height, will require careful demonstration of the fact that, for different PPs, what matters is their position relative to Voice.

In summary, the binding/agreement interaction in Turkish provides not only an argument in favor of the involvement of Agree in binding, but also a window into its limits. We have seen that it is possible for local binding to take place without leaving the morphological signature of agreement. Whether binding results in co-

varying agreement or not seems to track an argument/adjunct distinction, the source of which we have speculated on but leave open for future work.

If the preliminary conclusion sketched here is on the right track, theories of binding that initially seem in conflict may simply be making reference to different aspects of the phenomenon. Agree-based theories correctly maintain that ϕ -features may be crucially implicated in binding; theories explicitly eschewing Agree (e.g. Charnavel and Sportiche 2016) correctly state that not all instances of local binding can be reduced to the operation; and coargumenthood-based theories correctly privilege the binding of arguments by other arguments. Whether a broad reconciliation of these different approaches is possible more generally is a question that merits further discussion, and the possibility that local anaphoric binding can be carried out in more than one way deserves to be explored further.

Finally, note that the problem that this section started with is not entirely resolved. The starting point for the discussion of binding into PPs was that PPs may often be opaque for agreement, but not for binding. But the discussion so far predicts that PPs should be able to be bound into via Agree, all things being equal, as long as they are c-commanded by the head that mediates binding. This prediction raises an interesting question: why should low, “argumental” PPs like the benefactive in (109) be more likely to be transparent for Agree? Could it be that the adpositions introducing arguments in the specifiers of functional heads differ from adjoined adpositions, either because they are added post-syntactically; because they spell out a category distinct from P (e.g. Case); or because they trigger movement of anaphors to their edge (Messick and Raghotham 2022)? These questions are left open.

5 Conclusion

This paper began from the observation that the empirical space defined by Agree-based theories of binding has been relatively unexplored: in particular, there has been little empirically-oriented discussion of whether binding and agreement can be shown to be mutually dependent. We have offered a case study from (a variety of) Turkish illustrating mutual dependence of just this kind, in which certain nominals (the so-called *Default Triggering Nominals*) may show co-varying nominal agreement only in the presence of a bindee. We have argued that the details follow if binding can involve transmission of ϕ -features from the antecedent to the anaphor or bound pronoun, mediated by a functional head we have called $\text{Voice}_{\text{MINIMAL}}$.

The paper has also provided an account of the internal structure of DTNs, which show default agreement to be the result of the interplay of two factors: the distribution of ϕ -features across these complex pronominals, and the feature specifications of different probes. In so doing, we have touched upon important issues in the domain of agreement more generally, including conditions on (cyclic) probing, the importance of how ϕ -features are structured on the goal, and agreement with coordinations.

Once empirical considerations lead us to conclude that binding can involve Agree, it is necessary to ask whether it always does. We have argued that Turkish also sheds light on this question, and that preliminary evidence from binding into PPs suggests that the role of Agree in binding is limited. If there is more than one way to bind

anaphors and bound pronouns, it becomes possible to envisage an integration of insights from seemingly incompatible theories of binding.

The contribution of this paper lies not in technical elaborations of how binding is achieved via Agree; proposals addressing this important issue abound as it is. Rather, we have tried to highlight the importance of considering morphological evidence for or against different theories of binding; and to offer a novel argument in favor of a view whereby Agree constitutes one way to bind, albeit not the only one.

Acknowledgements This work has benefited greatly from very many discussions with Julie Anne Legate, David Embick, and Martin Salzmann. We are also grateful to Byron Ahn, Elena Anagnostopoulou, Ümit Atlamaz, Asli Kuzgun, Johanna Benz, Rajesh Bhatt, Benjamin Bruening, Isabelle Charavel, Ksenia Ershova, Sabine Iatridou, Alex Kalomirois, Jaklin Kornfilt, Alec Marantz, Deniz Özyıldız, Deniz Satık, Satoshi Tomioka, Seth Cable, Vincent Homer and audiences at Aydın University, CreteLing 2019, FMART, the Syntax Reading Group at Penn, the LSA 2020 Annual Meeting, 5th Workshop on Turkic and languages in contact with Turkic (Tu+ 5), and NELS 51 for helpful feedback. We are also indebted to three anonymous *NLLT* reviewers, and to the handling editor Vera Gribanova, for comments and questions that led to substantial improvements of the claims and presentation. Finally, we are grateful to Uğurcan Vurgun, Leyla Zidani-Eroğlu, Jaklin Kornfilt, Yılmaz Köylü, Deniz Özyıldız, Ümit Atlamaz, Hande Sevgi, Özlem Ergelen, Neşe Demir, Öner Özçelik, Bülent Akkuş, Turan Akkuş, İbrahim Yıldırım, Leyla Gülten, Mustafa Akbağ, Hasibe Gülen and a few other consultants who wished to remain anonymous for their judgments. All errors remain our own.

Declarations

Competing Interests The authors declare that they have no conflict of interest.

Open Access This article is licensed under a Creative Commons Attribution 4.0 International License, which permits use, sharing, adaptation, distribution and reproduction in any medium or format, as long as you give appropriate credit to the original author(s) and the source, provide a link to the Creative Commons licence, and indicate if changes were made. The images or other third party material in this article are included in the article's Creative Commons licence, unless indicated otherwise in a credit line to the material. If material is not included in the article's Creative Commons licence and your intended use is not permitted by statutory regulation or exceeds the permitted use, you will need to obtain permission directly from the copyright holder. To view a copy of this licence, visit <http://creativecommons.org/licenses/by/4.0/>.

References

- Adger, David. 2010. A minimalist theory of feature structure. In *Features: Perspectives on a key notion in linguistics*, eds. Anna Kibort and Greville G. Corbett, 185–220. London: Oxford University Press. <https://doi.org/10.1093/acprof:oso/9780199577743.003.0008>
- Adger, David, and Daniel Harbour. 2007. Syntax and syncretisms of the Person Case Constraint. *Syntax* 10(1): 2–37. <https://doi.org/10.1111/j.1467-9612.2007.00095.x>
- Ahn, Byron Thomas. 2015. Giving reflexivity a Voice: Twin reflexives in English. PhD diss., University of California, Los Angeles.
- Ahn, Byron Thomas. 2019. Reflexive binding without phi-feature matching. Conference presentation, 2019 annual meeting of the LSA, New York, NY.
- Akkuş, Faruk. 2020. On Iranian case and agreement. *Natural Language & Linguistic Theory* 38(3): 671–727. <https://doi.org/10.1007/s11049-019-09457-8>
- Akkuş, Faruk. 2021. (Implicit) argument introduction, Voice and causatives. PhD diss., University of Pennsylvania.
- Akkuş, Faruk. 2022. C and T are distinct probes. In *Proceedings of the fifty-second annual meeting of the North East Linguistic Society (NELS 52)*, eds. Özge Bakay, Breanna Pratley, Eva Neu, and Peyton Deal, 1–14. GLSA.

- Al Khalaf, Eman. 2021. Furthest conjunct agreement in Jordanian Arabic: Evidence for multiple (non)-simultaneous Agree. *Natural Language & Linguistic Theory* 40(2): 345–391. <https://doi.org/10.1007/s11049-021-09515-0>
- Anagnostopoulou, Elena. 2005. Strong and weak person restrictions: A feature checking analysis. In *Clitic and affix combinations: Theoretical perspectives*, eds. Lorie Heggie and Francisco Ordóñez, 199–235. Amsterdam: Benjamins. <https://doi.org/10.1075/la.74.08Ana>
- Antonenko, Andrei. 2011. Feature-based binding and phase theory. PhD diss., Stony Brook University.
- Antonenko, Andrei. 2018. Principle A and feature valuation. *Proceedings of the Linguistic Society of America* 3(1): 37. <https://doi.org/10.3765/plsa.v3i1.4325>.
- Aoun, Joseph. 1999. Clitic-doubled arguments. In *Beyond principles and parameters: Essays in memory of Osvaldo Jaeggli*, eds. Kyle Johnson and Ian Roberts, 13–42. Dordrecht: Kluwer Academic. https://doi.org/10.1007/978-94-011-4822-1_2
- Arslan-Kechriotis, Ceyda. 2006. Case as an uninterpretable feature. PhD diss., Bogaziçi University.
- Arslan-Kechriotis, Ceyda. 2009. *Determiner phrase and case in Turkish: A minimalist account*. Saarbrücken: VDM Publishing House.
- Aydın, Özgür. 2008. Agreement with partitive quantifiers in Turkish. In *Essays on Turkish linguistics: Proceedings of the 14th international conference on Turkish linguistics*, 197–226. Wiesbaden: Harrassowitz.
- Aygen, Gülşat N. 2007. Syntax and semantics of genitive subject-case in Turkic. *California Linguistic Notes* 32(2): 1–39.
- Bader, Monika. 2011. Constraining operations: A phase-based account of improper movement and anaphoric binding. PhD diss., University of Tromsø.
- Baker, Mark C., and Nadya Vinokurova. 2010. Two modalities of case assignment: Case in Sakha. *Natural Language & Linguistic Theory* 28: 593–642. <https://doi.org/10.1007/s11049-010-9105-1>
- Béjar, Susana. 2003. Phi-syntax: A theory of agreement. Phd diss., University of Toronto.
- Béjar, Susana. 2008. Conditions on phi-agree. In *Phi theory: Phi-features across modules and interfaces*, eds. Daniel Harbour, David Adger, and Susana Béjar, 130–154. Oxford: Oxford University Press.
- Béjar, Susana, and Milan Rezac. 2009. Cyclic Agree. *Linguistic Inquiry* 40(1): 35–73. <http://dx.doi.org/10.1162/ling.2009.40.1.35>
- Benmamoun, Elabbas, Archana Bhatia, and Maria Polinsky. 2009. Closest conjunct agreement in head final languages. *Linguistic Variation Yearbook* 9(1): 67–88. <https://doi.org/10.1075/ivy.9.02ben>
- Bhatt, Rajesh. 2005. Long distance agreement in Hindi-Urdu. *Natural Language & Linguistic Theory* 23(4): 757–807. <https://doi.org/10.1007/s11049-004-4136-0>
- Bhatt, Rajesh, and Martin Walkow. 2013. Locating agreement in grammar: An argument from agreement in conjunctions. *Natural Language & Linguistic Theory* 31(4): 951–1013. <https://doi.org/10.1007/s11049-013-9203-y>
- Borsley, Robert D., and Jaklin Kornfilt. 1999. Mixed extended projections. In *The nature and function of syntactic categories*, ed. Robert D. Borsley, *Syntax and semantics*, 101–131. Bingley: Emerald. https://doi.org/10.1163/9781849500098_006
- Bruening, Benjamin. 2021. Generalizing the presuppositional approach to the binding conditions. *Syntax* 24(4): 417–461. <https://doi.org/10.1111/synt.12221>.
- Charnavel, Isabelle. 2019. *Locality and logophoricity: A theory of exempt anaphora*. New York; Oxford: Oxford University Press. <https://doi.org/10.1093/oso/9780190902100.001.0001>
- Charnavel, Isabelle, and Shannon Bryant. 2023. The whole picture: Disentangling locality, logophoricity and subjecthood in picture noun anaphora. *Natural Language & Linguistic Theory* 41: 547–610. <https://doi.org/10.1007/s11049-022-09548-z>
- Charnavel, Isabelle, and Dominique Sportiche. 2016. Anaphor binding: What French inanimate anaphors show. *Linguistic Inquiry* 47(1): 35–87. https://doi.org/10.1162/LING_a_00204
- Chomsky, Noam. 1981. *Lectures on government and binding*. Dordrecht: Foris.
- Chomsky, Noam. 2000. Minimalist inquiries. In *Step by step: Essays on minimalism in honor of Howard Lasnik*, eds. Roger Martin, David Michaels, and Juan Uriagereka, 89–155. Cambridge: MIT Press.
- Chomsky, Noam. 2001. Derivation by phase. In *Ken Hale: A life in language*, ed. Michael Kenstowicz, 1–52. Cambridge: MIT Press. <https://doi.org/10.7551/mitpress/4056.003.0004>
- Citko, Barbara. 2018. Complementizer agreement with coordinated subjects in Polish. *Glossa: A Journal of General Linguistics* 3(1): 1–25. <https://doi.org/10.5334/gjgl.588>
- Coon, Jessica, and Alan Bale. 2014. The interaction of person and number in Mi'gmaq. *Nordlyd* 40(1): 85–101. <https://doi.org/10.7557/12.3235>
- Cowper, Elizabeth. 2010. Where auxiliary verbs come from. In *Proceedings of the 2010 annual conference of the Canadian Linguistic Association*, 1–16. Montreal: Concordia University.

- Deal, Amy Rose. 2010. Ergative case and the transitive subject: A view from Nez Perce. *Natural Language & Linguistic Theory* 28(1): 73–120. <https://doi.org/10.1007/s11049-009-9081-5>.
- Deal, Amy Rose. 2022. Interaction, satisfaction, and the PCC. *Linguistic Inquiry*. https://doi.org/10.1162/ling_a_00455.
- Drummond, Alex, Dave Kush, and Norbert Hornstein. 2011. Minimalist construal: Two approaches to A and B. In *The Oxford handbook of linguistic minimalism*, ed. Cedric Boeckx, 396–426. Oxford: Oxford University Press. <http://dx.doi.org/10.1093/oxfordhb/9780199549368.013.0018>
- Frampton, John, and Sam Gutmann. 2000. Agreement is feature sharing. Ms., Northeastern University, Boston, MA.
- George, Leland, and Jaklin Kornfilt. 1981. Finiteness and boundedness in Turkish. In *Binding and filtering*, ed. Frank Heny, 104–127. Cambridge: MIT Press.
- Ghomeshi, Jila, and Diane Massam. 2020. Number is different in nominal and pronominal phrases. *Linguistic Inquiry* 51(3): 597–610. https://doi.org/10.1162/ling_a_00350
- Grosz, Patrick Georg. 2015. Movement and agreement in right-node-raising constructions. *Syntax* 18(1): 1–38. <https://doi.org/10.1111/synt.12024>
- Halle, Morris, and Alec Marantz. 1993. Distributed morphology and the pieces of inflection. In *The view from Building 20: Essays in linguistics in honour of Sylvain Bromberger*, eds. Ken Hale and Samuel J. Keyser, 111–176. Cambridge: MIT Press.
- Harley, Heidi, and Elizabeth Ritter. 2002. Person and number in pronouns: A feature-geometric analysis. *Language* 78(3): 482–526. <https://doi.org/10.1353/lan.2002.0158>
- Heinat, Fredrik. 2009. Probing phrases, pronouns, and binding. In *Merging features*, eds. José M. Brucart, Anna Gavarró, and Jaume Solà. London: Oxford University Press. <https://doi.org/10.1093/acprof:oso/9780199553266.003.0002>
- Hicks, Glyn. 2009. *The derivation of anaphoric relations*. Amsterdam: John Benjamins. <https://doi.org/10.1075/la.139>
- Hiraiwa, Ken. 2001. Multiple Agree and the defective intervention constraint in Japanese. In *MIT working papers in linguistics*, Vol. 40, 67–80.
- Hiraiwa, Ken. 2005. Dimensions of symmetry in syntax: Agreement and clausal architecture. PhD diss., MIT.
- Höhn, Georg F. K. 2016. Unagreement is an illusion: Apparent person mismatches and nominal structure. *Natural Language & Linguistic Theory* 34(2): 543–592. <https://doi.org/10.1007/s11049-015-9311-y>.
- Höhn, Georg F. K. 2020. The third person gap in adnominal pronoun constructions. *Glossa: A Journal of General Linguistics* 5(1): 1–43. <https://doi.org/10.5334/gjgl.1121>
- Hornstein, Norbert. 2001. *Move!: A minimalist theory of construal*. Malden: Blackwell.
- Hornstein, Norbert. 2007. Pronouns in a minimalist setting. In *The copy theory of movement*, eds. Norbert Corver and Jairo Nunes. *Linguistik aktuell/Linguistics today*, 351–385. Amsterdam: Benjamins. <https://doi.org/10.1075/la.107.15hor>.
- Ince, Atakan. 2008. On default agreement in Turkish. Ms., University of Maryland, College Park.
- Ince, Atakan, and Özgür Aydın. 2015. Copular structures as (non)phases in Turkish: Synchronic and diachronic perspective. In *Ankara papers in Turkish and Turkic linguistics*, eds. Deniz Zeyrek, Çiğdem Sağın Şimşek, Jochen Rehbein, and Ufuk Atas. Vol. 113 of *Turcologica*, 87–98. Wiesbaden: Harrasowitz.
- Kayne, Richard. 2000. *Parameters and universals*. New York: Oxford University Press.
- Kayne, Richard. 2002. Pronouns and their antecedents. In *Derivation and explanation in the minimalist program*, eds. Samuel David Epstein and T. Daniel Seely, 133–166. Oxford: Blackwell. <https://doi.org/10.1002/9780470755662.ch7>
- Kelepir, Meltem. 2021. Matters of size and deficient functional categories in three Turkic languages: Turkish, Turkmen, and Noghay. In *The size of things I: Structure building*, eds. Sabine Laszakovits and Zheng Shen, 25–44. Berlin: Language Science Press. <https://doi.org/10.5281/zenodo.5524276>
- Kennelly, Sarah. 1997. Nonspecific external arguments in Turkish. *Dilbilim Araştırmaları Dergisi* 8: 58–75.
- Ketrez, Nilhan. 2010. IAR-marked nominals and three types of plurality in Turkish. In *Proceedings of CLS*, Vol. 39, eds. Jon Cihlar, Amy Franklin, David Kaiser, and Irene Kimbara, 176–192. Chicago: University of Chicago.
- Key, Gregory. 2021. Passive in Turkish: Re-thinking *u*-syncretism. Ms., SUNY Binghamton.
- Kornfilt, Jaklin. 1984. Case marking, agreement, and empty categories in Turkish. PhD diss., Harvard University.
- Kornfilt, Jaklin. 1997. *Turkish*. London: Routledge. <https://doi.org/10.4324/9781315823652>

- Kornfilt, Jaklin. 2001. Local and long-distance reflexives in Turkish. In *Long-distance reflexives*, eds. Peter Cole, Gabriella Hermon, and C. T. James Huang. *Syntax and semantics*, 197–226. Leiden: Brill. https://doi.org/10.1163/9781849508742_007
- Kornfilt, Jaklin. 2003. Subject case in Turkish nominalized clauses. In *Syntactic structures and morphological information*, eds. Uwe Junghanns and Luka Szucsich. *Interface explorations*, 129–215. Berlin: Mouton de Gruyter. <https://doi.org/10.1515/9783110904758.129>
- Kornfilt, Jaklin. 2007. Verbal and nominalized finite clauses in Turkish. In *Finiteness: Theoretical and empirical foundations*, ed. Irina Nikolaeva, 305–332. Oxford: Oxford University Press.
- Kornfilt, Jaklin, and Omer Preminger. 2015. Nominative as no case at all: An argument from raising-to-acc in Sakha. In *Proceedings of the 9th Workshop on Altaic Formal Linguistics (WAFL 9)*, eds. Andrew Joseph and Esra Predolac. *MIT working papers in linguistics*, 109–120. Cambridge: MITWPL.
- Kornfilt, Jaklin, and John Whitman. 2011. Afterword: Nominalizations in syntactic theory. *Lingua* 121(7): 1297–1313. <https://doi.org/10.1016/j.lingua.2011.01.008>.
- Kratzer, Angelika. 1996. Severing the external argument from its verb. In *Phrase structure and the lexicon*, eds. Johan Rooryck and Laurie Zaring, 109–137. Dordrecht: Springer. https://doi.org/10.1007/978-94-015-8617-7_5
- Kratzer, Angelika. 2009. Making a pronoun: Fake indexicals as windows into the properties of pronouns. *Linguistic Inquiry* 40(2): 187–237. <https://doi.org/10.1162/ling.2009.40.2.187>
- Kunduraci, Aysun. 2013. Turkish NN compounds: A process-based paradigmatic account. PhD diss., University of Calgary.
- Labelle, Marie. 2008. The French reflexive and reciprocal se. *Natural Language & Linguistic Theory* 26(4): 833–876. <https://doi.org/10.1007/s11049-008-9053-1>.
- Lebeaux, David. 1991. *Relative clauses, licensing, and the nature of the derivation*, 209–239. Leiden: Brill. https://doi.org/10.1163/9789004373198_011.
- Legate, Julie Anne. 2014. *Voice and v: Lessons from Acehnese*. Cambridge: MIT Press. <https://doi.org/10.7551/mitpress/9780262028141.001.0001>
- Legate, Julie Anne, Faruk Akkuş, Milena Šereikaitė, and Don Ringe. 2020. On passives of passives. *Language* 96(4): 771–818. <https://doi.org/10.1353/lan.2020.0062>.
- Lim, Jun Jie. 2022. Dissociating genitive case assignment and possessor agreement – Evidence from Khalkha Mongolian nominalised clauses. Proceedings of WAFL16. MIT Working Papers in Linguistics.
- Link, Godehard. 1983. The logical analysis of plurals and mass terms: A lattice-theoretical approach. In *Meaning, use and interpretation of language*, eds. Rainer Bäuerle, Christoph Schwarze, and Arnim von Stechow, 303–329. Berlin: de Gruyter. <https://doi.org/10.1515/9783110852820.302>
- Martinović, Martina. 2022. Feature geometry and head-splitting in the Wolof clausal periphery. *Linguistic Inquiry* 54(1): 79–116. https://doi.org/10.1162/ling_a_00447
- Marušič, Franc, Andrew Ira Nevins, and William Badecker. 2015. The grammars of conjunction agreement in Slovenian. *Syntax* 18(1): 39–77. <https://doi.org/10.1111/synt.12025>
- Messick, Troy, and Sreekar Raghotheram. 2022. On case-copying reflexives: Implications for antecedent-anaphor feature matching. Ms., Rutgers University.
- Moskal, Beata. 2015. Limits on allomorphy: A case study in nominal suppletion. *Linguistic Inquiry* 46(2): 363–376. https://doi.org/10.1162/LING_a_00185.
- Munn, Alan. 1993. Topics in the syntax and semantics of coordinate structures. PhD diss., University of Maryland, College Park.
- Munn, Alan. 1999. First conjunct agreement: Against a clausal analysis. *Linguistic Inquiry* 30(4): 643–668. <https://doi.org/10.1162/002438999554246>
- Murphy, Andrew, and Savio Meyase. 2022. Licensing and anaphora in Tenyidie. *Glossa: A Journal of General Linguistics* 7(1): 1–59. <https://doi.org/10.16995/glossa.5740>
- Murugesan, Gurujegan. 2019. Predicting the Anaphor Agreement Effect and its violations. PhD diss., Universität Leipzig.
- Murugesan, Gurujegan. 2022. Deriving the anaphor-agreement effect and the violations of it. *Syntax* 25(1): 39–83. <https://doi.org/10.1111/synt.12227>
- Nevins, Andrew. 2011. Multiple Agree with clitics: Person complementarity vs. omnivorous number. *Natural Language & Linguistic Theory* 29(4): 939–971. <https://doi.org/10.1007/s11049-011-9150-4>
- Nevskaya, Irina. 2010. Inclusive and exclusive in Altaic languages. In *Transeurasian verbal morphology in a comparative perspective: Genealogy, contact, chance*, eds. Lars Johanson and Martine Robbeets, 115–129. Wiesbaden: Harrassowitz. <https://doi.org/10.1075/tsl.63.16nev>
- Öztürk, Balkız. 2005. *Case, referentiality and phrase structure*. Amsterdam: John Benjamins. <https://doi.org/10.1075/la.77>

- Paparonas, Lefteris, and Faruk Akkuş. 2020. The anaphor agreement effect in the nominal domain: Evidence from Turkish. *Proceedings of the Linguistic Society of America* 5(1): 484–498. <https://doi.org/10.3765/plsa.v5i1.4725>
- Pesetsky, David, and Esther Torrego. 2007. The syntax of valuation and the interpretability of features. In *Phrasal and clausal architecture: Syntactic derivation and interpretation*, eds. Simin Karimi, Vida Samiiian, and Wendy K. Wilkins. 262–294. Amsterdam: John Benjamins. <https://doi.org/10.1075/la.101.14pes>.
- Pietraszko, Joanna Aleksandra. 2016. The syntax of simple and compound tenses in Ndebele. In *Proceedings of the Linguistic Society of America*, 1–15. <https://doi.org/10.3765/plsa.v1i0.3716>
- Pollard, Carl, and Ivan A. Sag. 1992. Anaphors in English and the scope of binding theory. *Linguistic Inquiry* 23(2): 261–303. <http://www.jstor.org/stable/4178768>.
- Predolac, Esra. 2017. The syntax of sentential complementation in Turkish. PhD diss., Cornell University.
- Preminger, Omer. 2011. Agreement as a fallible operation. PhD diss., MIT.
- Preminger, Omer. 2014. *Agreement and its failures*. Cambridge: MIT Press. <https://doi.org/10.7551/mitpress/9780262027403.001.0001>
- Preminger, Omer. 2019. The Anaphor Agreement Effect: Further evidence against binding-as-agreement. Ms., University of Maryland, College Park.
- Pylkkänen, Liina. 2008. *Introducing arguments*. Cambridge: MIT Press. <https://doi.org/10.7551/mitpress/9780262162548.001.0001>
- Quicoli, A. Carlos. 2008. Anaphora by phase. *Syntax* 11(3): 299–329. <https://doi.org/10.1111/j.1467-9612.2008.00116.x>.
- Reinhart, Tanya, and Eric Reuland. 1993. Reflexivity. *Linguistic Inquiry* 24(4): 657–720.
- Reuland, Eric J. 2001. Primitives of binding. *Linguistic Inquiry* 32(3): 439–492. <https://doi.org/10.1162/002438901750372522>
- Reuland, Eric J. 2006. Agreeing to bind. In *Organizing grammar: Studies in honor of Henk van Riemsdijk*, eds. Hans Broekhuis, Norbert Corver, Riny Huybregts, Ursula Kleinhenz, and Jan Koster, 505–513. Berlin: Mouton de Gruyter. <https://doi.org/10.1515/9783110892994.505>
- Reuland, Eric J. 2011. *Anaphora and language design*. Cambridge: MIT Press.
- Rezac, Milan. 2003. The fine structure of cyclic agree. *Syntax* 6(2): 156–182. <https://doi.org/10.1111/1467-9612.00059>.
- Rezac, Milan. 2008. Phi-Agree and theta-related case. In *Phi theory: Phi-features across modules and interfaces*, eds. Daniel Harbour, David Adger, and Susana Béjar, 83–129. Oxford: Oxford University Press.
- Ritter, Elizabeth. 1991. Two functional categories in noun phrases: Evidence from Modern Hebrew. In *Perspectives on phrase structure: Heads and licensing*, 37–62. Leiden: Brill. https://doi.org/10.1163/9789004373198_004
- Rizzi, Luigi. 1990. On the anaphor-agreement effect. *Rivista di Linguistica* 2: 27–42.
- Rooryck, Johan, and Guido J. vanden Wyngaerd. 2011. *Dissolving binding theory*. New York; Oxford: Oxford University Press. <https://doi.org/10.1093/acprof:oso/9780199691326.001.0001>
- Rudnev, Pavel. 2020. The Anaphor Agreement Effect is not about featural deficiency: Evidence from Avar. *Glossa: A Journal of General Linguistics* 5(1): 1–19. <https://doi.org/10.5334/gjgl.907>
- Safir, Ken. 2014. One true anaphor. *Linguistic Inquiry* 45(1): 91–124. https://doi.org/10.1162/ling_a_00149
- Satuk, Deniz. 2020. Turkic genitive case and agreement asymmetries. Ms., Harvard University.
- Şener, Serkan. 2008. Non-canonical case licensing is canonical-accusative subjects of CPs in Turkish. Ms., UConn.
- Shiraki, Hitoshi. 2004. Anaphors, agreement and case. *UCL Working Papers in Linguistics* 16: 39.
- Spathas, Giorgos, Artemis Alexiadou, and Florian Schäfer. 2015. Middle Voice and reflexive interpretations: afto-prefixation in Greek. *Natural Language & Linguistic Theory* 33(4): 1293–1350. <https://doi.org/10.1007/s11049-014-9279-z>.
- Sundaesan, Sandhya. 2015. Anaphora vs agreement: A new kind of Anaphor Agreement Effect in Tamil. In *The Impact of Pronominal Form on Interpretation*, eds. Patrick Georg Grosz and Pritty Patel-Grosz, 77–105. Berlin: Mouton de Gruyter. <https://doi.org/10.1515/9781614517016-004>
- Tucker, Matthew A. 2011. On the derivation of the Anaphor Agreement Effect. Ms., University of California, Santa Cruz.
- van Koppen, Marjo. 2005. *One probe – two goals: Aspects of agreement in Dutch dialects*. Utrecht: LOT.
- Van Urk, Coppe. 2015. A uniform syntax for phrasal movement: A case study of Dinka Bor. PhD diss., MIT.

- Woolford, Ellen. 1999. More on the Anaphor Agreement Effect. *Linguistic Inquiry* 30(2): 257–287. <https://doi.org/10.1162/002438999554057>
- Wurmbrand, Susi. 2017. Feature sharing or how I value my son. In *A Pesky set: Papers for David Pesetsky*, eds. Claire Halpert, Hadas Kotek, and Coppe van Urk. *MIT working papers in linguistics*, 173–182. Cambridge: MIT Press.
- Yuan, Michelle. 2023. Case as an anaphor agreement effect: Evidence from Inuktitut. *Linguistic Inquiry* 54(2): 413–428. https://doi.org/10.1162/ling_a_00443
- Zidani-Eroğlu, Leyla. 1997. Exceptionally case-marked NPs as matrix objects. *Linguistic Inquiry* 28(2): 219–230.
- Zwart, Jan-Wouter. 2002. Issues relating to a derivational theory of binding. In *Derivation and explanation in the minimalist program*, eds. Samuel David Epstein and T. Daniel Seely, 269–304. Malden: Blackwell Publishing. <https://doi.org/10.1002/9780470755662.ch12>.

Publisher's Note Springer Nature remains neutral with regard to jurisdictional claims in published maps and institutional affiliations.