



Maternal Mental Health and Children's Problem Behaviours: A Bi-directional Relationship?

Emily Lowthian^{1,4} · Stuart Bedston¹ · Sara Madeleine Kristensen³ · Ashley Akbari¹ · Richard Fry¹ · Katy Huxley² · Rhodri Johnson¹ · Hyun Sue Kim⁵ · Rhiannon K. Owen¹ · Chris Taylor² · Lucy Griffiths¹

Accepted: 24 May 2023 / Published online: 4 July 2023
© The Author(s) 2023

Abstract

Transactional theory and the coercive family process model have illustrated how the parent-child relationship is reciprocal. Emerging research using advanced statistical methods has examined these theories, but further investigations are necessary. In this study, we utilised linked health data on maternal mental health disorders and explored their relationship with child problem behaviours via the Strengths and Difficulties Questionnaire for over 13 years. We accessed data from the Millennium Cohort Study, linked to anonymised individual-level population-scale health and administrative data within the Secure Anonymised Information Linkage (SAIL) Databank. We used Bayesian Structural Equation Modelling, specifically Random-Intercept Cross-Lagged Panel Models, to analyse the relationships between mothers and their children. We then explored these models with the addition of time-invariant covariates. We found that a mother's mental health was strongly associated over time, as were children's problem behaviours. We found mixed evidence for bi-directional relationships, with only emotional problems showing bi-directional associations in mid to late childhood. Only child-to-mother pathways were identified for the overall problem behaviour score and peer problems; no associations were found for conduct problems or hyperactivity. All models had strong between-effects and clear socioeconomic and sex differences. We encourage the use of whole family-based support for mental health and problem behaviours, and recommend that socioeconomic, sex and wider differences should be considered as factors in tailoring family-based interventions and support.

Keywords Maternal mental health · Child development · Structural equation modelling · Millennium Cohort Study · Bayesian analysis

Introduction

Maternal mental health represents one of the earliest influences on a child's development, and research shows that maternal mental illness may negatively affect child development, behaviour, cognitive, and socio-emotional development (Kingston & Tough, 2014) even after adjustment for key covariates such as socioeconomic status (Mensah & Kiernan, 2010). While a considerable body of research has examined how parental mental illness can affect children's mental health (Goodman et al., 2011; Kingston & Tough, 2014; Reupert & Maybery, 2016; Yamamoto & Keogh, 2018) and access to services (Acri et al., 2017; Fledderjohann et al., 2021; Haime-Schlagel et al., 2018; Pfefferle & Spitznagel, 2009), fewer studies assess how child problem behaviours impact parental mental health (Goodman et al., 2011; Xerxa et al., 2021). There is a need to consider the complex interplay of interactions between parent and child,

Stuart Bedston and Sara Madeleine Kristensen equally contributed.

✉ Emily Lowthian
e.m.lowthian@swansea.ac.uk

- ¹ Population Data Science, Swansea University Medical School, Swansea University, Singleton Park, Swansea SA2 8PP, Wales
- ² School of Social Sciences, WISERD, Cardiff University, Wales, UK
- ³ Department of Health Promotion and Development, University of Bergen, Bergen 5020, Norway
- ⁴ Department of Education and Childhood Studies, School of Social Sciences, Swansea University, Swansea SA2 8PP, Wales
- ⁵ Virginia Tech Carilion School of Medicine, 2 Riverside Circle, Roanoke, VA 24016, United States

labelled ‘bi-directional associations’ by Bell (1968, 1971) and Sameroff (1975). In this paper, we draw on transactional theory and findings from recent, methodologically advanced studies to inform our investigation.

Transactional Theory

Interactions between the parent and child have been largely influenced by Bell (1968), who provided a catalyst for research exploring the two-way exchange of behaviours from parent to child, and vice-versa (Pettit & Arsiwalla, 2008). Bell (1971) explained that seeing children as passive recipients of their interactions with others is a limited perspective as it fits a one-sided model of parental determination of behaviour (Sameroff, 1975). Rather than viewing children as a static environment, there is a recognition that children are in a “perpetual state of active reorganization” (Sameroff, 1975, p. 8), and their development is shaped by the environment *and* their interaction with an experience. In a *transactional* conceptualisation of risk, it is recognised that proximal and distal factors occur in a dynamic interplay, whereby the child is influenced by the environment *yet* simultaneously responds to the environment and so forth (Cicchetti & Toth, 1997). As life progresses, they are driven by new complexities at both the individual and experience levels, and these require new adaptations (Sameroff, 2009).

Within parent-child relationships, the labelling of a child by a parent as ‘difficult’ may result in persistent labelling regardless of actual behaviour. In turn, a child may accept this labelling and increase difficult behaviour (Sameroff, 1975). This is often referred to as the Coercive Process Model (Patterson, 1982, 2002a). Belsky (1984) further developed the Process Model giving greater recognition to how child characteristics influenced parenting. For example, in Field et al. (1988) infants (aged 3–6 months) of mothers with depressive symptoms showed greater ‘depressed’ behaviour even when interacting with mothers without depressive symptoms, and the ‘non-depressed’ group of mothers began to exhibit depressive manners in interactions with infants.

The understanding of bi-directional relationships has advanced into other fields, such as parental mental health or psychopathology and child problems (e.g., Gross et al., 2008; Xerxa et al., 2021), recognising the mutual influence between a child and their environment as a continuous dynamic interacting with the social context (similar to e.g., Pettit & Arsiwalla 2008). Building on Gross et al. (2008) maternal depression compromises parenting (Galbally & Lewis, 2017; Vreeland et al., 2019) which is associated with increased child problems (Middleton et al., 2009; Riany et al., 2022; Sweeney & MacBeth, 2016). Subsequently, parents experience a decrease in their parenting competency,

which may prolong or intensify the feelings of depression (Cutrona & Troutman, 1986; Nelson et al., 2003). Alongside the complex relationship between parent and child exists the wider environment, including structural determinants such as socioeconomic status. For example, Sameroff (2000) explains how maternal mental health problems can often sit within the contexts of poverty, lack of social support, stressful life events and low cultural capital; the theory that advantaged families (economically and socially) have greater access to knowledge and systems which promote positive child outcomes (Bourdieu, 1985). Consequently, the individual, family, and wider environmental factors combine to influence child development (Bronfenbrenner, 1979).

Recent Findings and Advanced Methodologies

In recent years, more advanced methodological techniques have been used to further quantify and test bi-directional associations between parental and child problems (Cortés-García et al., 2019; Hickey et al., 2020; Speyer et al., 2022; Xerxa et al., 2021). In terms of parental mental health and child development specifically, Xerxa et al. (2021) found bi-directional associations between maternal and paternal psychopathology and child behaviour problems using parent-reported data from the Netherlands (internalising and externalising symptoms). Associations were observed where the parent reported on both their own psychopathology symptoms and the child’s behaviour (termed as within-rater). But, there were either weak or no associations when examining maternal psychopathology and the paternal reports of child behaviour problems, nor between paternal psychopathology and maternal reports of child behaviour problems (termed as shared-rater). This illuminates the bias with parental reports of child behaviour. Speyer et al. (2022), using the Millennium Cohort Study (MCS) in the UK, examined parental distress and child behaviour problems (internalising and externalising symptoms) and found that maternal distress was associated with child internalising symptoms, while paternal distress was associated with increased problems for boys and decreased problems for girls. Bi-directional associations showed that internalising symptoms in boys and externalising symptoms in girls increased maternal distress; conversely, internalising symptoms in girls and externalising symptoms in boys increased paternal distress. There is, then, mixed evidence for understanding bi-directional associations.

Emerging evidence also suggests that providing care for a child who has hyperactivity problems provides additional demands and challenges (Johnston & Mash, 2001). While evidence suggests that parental factors are associated with the development of ADHD (Attention Deficit Hyperactivity

Disorder) or other areas of hyperactivity (Wüstner et al., 2019), less is known about the reverse. A longitudinal study by Breaux and Harvey (2019) found that child ADHD symptoms significantly predicted maternal depression symptoms and vice-versa; for fathers, only child effects were found with ADHD symptoms predicting paternal depression across the pre-school years. However, this study used cross-lagged panel models without a random intercept to estimate between-effects which has been criticised (Hamaker et al., 2015).

Other areas of child problem behaviours include interaction with their peers. Evidence suggests that maternal depression is associated with greater child peer problems (Waerden et al., 2015). A key mechanism in this relationship is parenting, wherein Wang et al. (2021) found no authoritative parenting practices (balance of warmth and control) in a group of Chinese parents with major depressive disorder, but identified authoritarian and permissive styles, which are considered less desirable; note however, that parenting is sensitive to cultural contexts (Stewart & Bond, 2002). Moreover, Yamagata et al. (2013) found bi-directional associations between parenting and peer problems independent of genetic and family covariates in a path analysis of 259 pairs of twins in early childhood. As parenting strain can be related to parental mental health (Borre & Kliever, 2014), our study will additionally explore if children's peer problems are related to maternal depression and then vice-versa.

In addition to the limited and mixed picture on bi-directional associations, further areas require investigation. First, despite some studies using clinical measures, the research base often uses self-reports of parental mental health to capture constructs of well-being (Mensah & Kiernan, 2010; Speyer et al., 2022; Xerxa et al., 2021). The use of these risk social desirability bias (Hunt et al., 2003; Sigmon et al., 2005) or responses depicting short-term mood, and in some data, self-reports had a lower prevalence of mental health problems than administrative records (O'Donnell et al., 2016). This is particularly significant when cohort studies capture the parent and child report on the same day – leading to problems with measurement bias (Najman et al., 2000; Ringoot et al., 2015). In addition, child sex has traditionally been a strong focus in bi-directional research, although factors such as socioeconomic status are also strongly associated with mental health in both adults (Finegan et al., 2018; Marmot & Bell, 2012) and children (Reiss, 2013) but often does not feature in much research. Therefore, studies should consider alternative measures of parental mental health and include key structural covariates in modelling to address these existing gaps.

The Present Study

This study examined the bi-directional associations between primary care maternal mental health records and parent-reported child problem behaviours. We adjusted for child sex and socioeconomic status to explore if bi-directional associations are sensitive to key individual and structural determinants. We also investigated the full range of child problems to explore associations in emotional and conduct problems, but also hyperactivity and peer problems, which are less developed in the field. We combined data from the Millennium Cohort Study (MCS) with anonymised individual-level population-scale health administrative data from the Secure Anonymised Information Linkage (SAIL) Data-bank in Wales.

Based on the theoretical assumptions in transactional theory (Bell, 1968, 1971; Belsky, 1984; Sameroff, 1975, 2000) and the coercive family process model (Patterson, 1982) and previous research in the field (e.g., Cortés-García et al., 2019; Hickey et al., 2020; Speyer et al., 2022; Xerxa et al., 2021), we hypothesised the following:

1. Maternal mental health problems and children's emotional, behavioural, hyperactivity, and peer problems are positively and concurrently related at a between- and within-person level.
2. There is a positive carry-over stability effect in children's emotional, behavioural, hyperactivity, and peer problems (i.e., deviation from one's own norm is associated with a similar deviation at subsequent time points).
3. Maternal mental health problems are positively associated with children's subsequent emotional, behavioural, hyperactivity, and peer problems.
4. Children's emotional, behavioural, hyperactivity, and peer problems are positively related to later maternal mental health problems.

Data and Methods

We linked data on Welsh-domiciled families from the MCS (Connelly & Platt, 2014) with administrative data from maternal mental health General Practice (GP) records. MCS sampled a cohort of all children born between 1st September 2000 and 31st August 2001 in Wales, with surveys (to date) at seven different time points (a child aged 0, 3, 4, 7, 11, 14 and 17 years old). To be included in the initial cohort, children had to be eligible to receive Child Benefit, a form of state benefit in the UK (Claim Child Benefit, 2021). The Welsh subgroup of the MCS was stratified by socioeconomic status, which over-sampled children residing in the economically poorest areas (ward-based Child Poverty Index) (Plewis, 2007). The families' consent was

obtained when the children were aged seven years old to link survey data to electronic health record (EHR) data sources, permitted up to the child's 14th birthday (Tingay et al., 2019). The data were accessed via the SAIL Databank, a Trusted Research Environment (TRE) in Wales for the 90.7% of families who consented to data linkage and approved through rigorous governance procedures (for further description of the de-identified data linkage procedures of MCS to health records, see Tingay et al. (2019)). We used probabilistic matching for more successful matches and higher quality. Figure 1 shows the sample selection process. We removed all households who never lived in Wales at any sweep and multiple births (i.e., twins), giving a linkage to 1,911 households, with linkage to GP data causing variation in the sample size across the MCS survey sweeps. We accessed the data following Information Governance Review Panel (IGRP) approval, which permits access to anonymised data via SAIL Databank.

Measures

Maternal Mental Health

Validated code lists for common mental health disorders (John et al., 2016) were used to select individuals who present with symptoms of, or are diagnosed or treated for, depression and anxiety. In Fig. 2, the time periods of each measure are shown; for example, maternal mental health at time-point 1 was any event between the child being aged 9 months old and 3 years old.

Child Problem Behaviours

Measures of child problem behaviours were taken from the MCS parent-reported data. We used the Strengths and Difficulties Questionnaire (SDQ), a brief emotional and behavioural screening questionnaire, capturing children's emotional, behavioural, hyperactivity or peer problems, with satisfactory reliability across internal consistency (α :

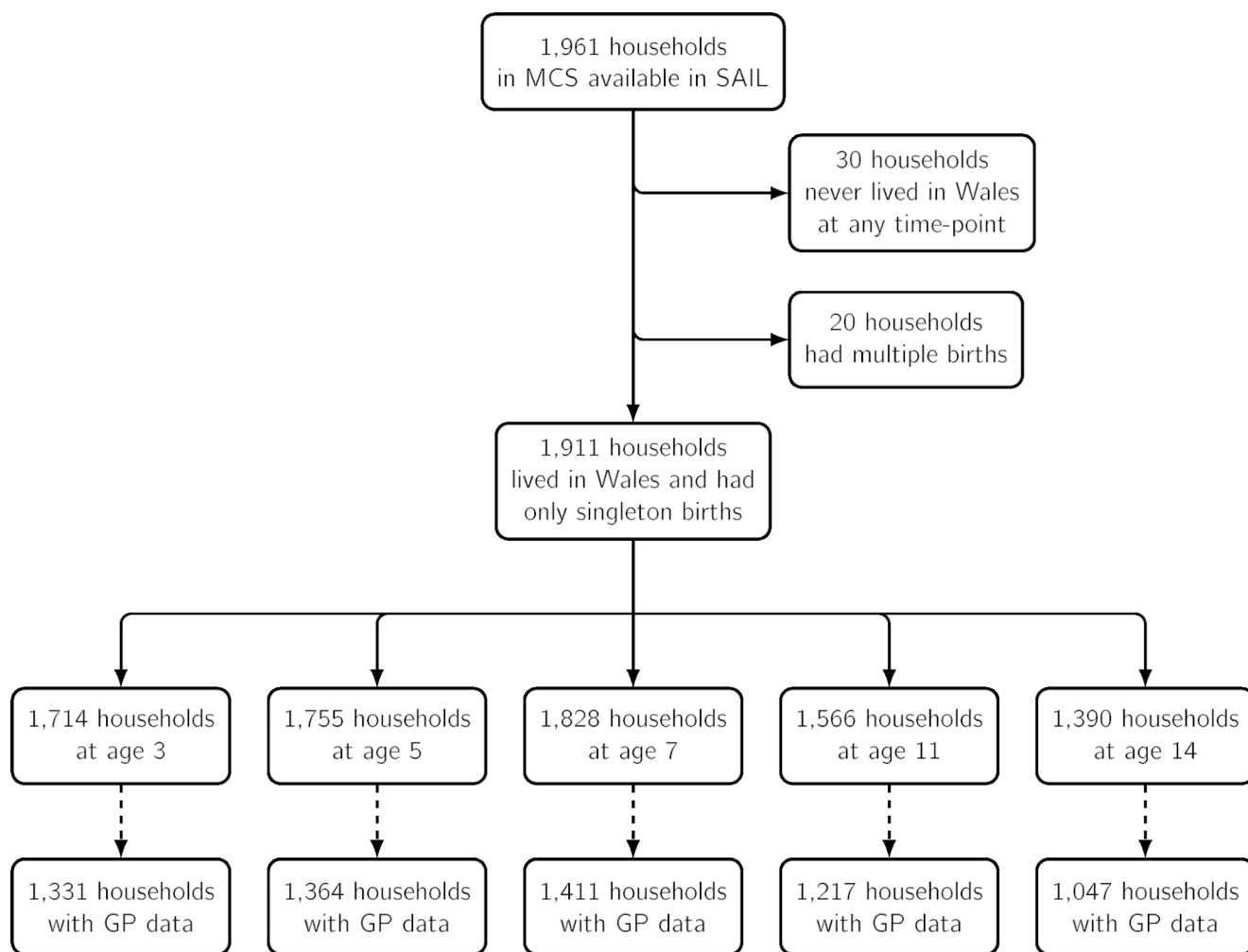
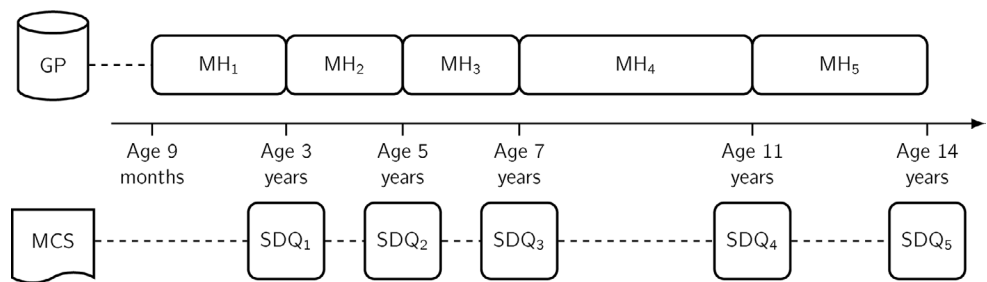

Fig. 1 Sample selection households available given time-point and data linkage availability

Fig. 2 Time periods of data collection for maternal mental health (MH_{1–5}) and child strengths and difficulties (SDQ_{1–5})



0.73) and cross-informant correlation (mean 0.34) (Goodman, 2001). A total SDQ score (derived from summing responses from the four subscales of emotional, conduct and peer problems along with hyperactivity) can be categorised into close to average, slightly raised, high and severe as per guidance (EHCAP, 2014). We analysed five SDQ outcomes of total strength and difficulties score, emotional problems, conduct problems, hyperactivity, and peer problems.

Demographics

We explored our sample distributions in terms of child sex (female/male), birth weight, gestational age, breastfeeding, family income and mothers' highest academic and/or vocational qualification whereby a higher qualification indicates more educational qualifications ('None', 'NVQ1 or GCSE D-G', 'NVQ2 or Apprenticeship or GCSE A* - C', 'NVQ3 or A-level', 'Professional qualification or Degree or Diploma or Health professional', 'Higher degree'); these measures were taken when the child was 9 months of age.

Data Analysis

We managed, cleaned, and conducted descriptive analysis in Stata 17 (StataCorp, 2021) and performed structural equation modelling in Mplus version 8.7 (Muthén & Muthén 2017). We specified five random intercept cross-lagged panel models (RI-CLPM) to analyse the longitudinal panel data for each child problem behaviour. The RI-CLPMs' temporal and concurrent associations between maternal mental health and children's problem behaviours were explored within individuals across the five time points shown in Fig. 2, an approach used by Kristensen et al. (2021). As Mund and Nestler (2019) discussed, the RI-CLPM permits each individual to fluctuate around their own stable, trait-like level over time with respect to the other variables in the model. This method was selected over the cross-lagged panel model (CLPM), which Hamaker et al. (2015) critiqued as an erroneous method to represent lagged estimates of within-person relationships over time.

We estimated these models using a Bayesian approach, and followed the new methodological guidance provided by Mplus, where categorical RI-CLPM are estimated by

residuals (Asparouhov & Muthén, 2021). In conducting the models, we used non-informative prior distributions and ensured the Posterior Predictive Check had intersected the null, and the p-value was > 0.05 (Asparouhov & Muthén, 2021). Likewise, we ensured the Proportional Scale Reduction (PSR) value evidenced a downward trend per iteration and that values were largely < 1.01 for good convergence. We visually inspected trace plots for all parameters to assess non-convergence (Muthén, 2010). If there appeared to be evidence of non-convergence, we increased the number of iterations and then thinned our models (selection of separated points at each k-th step) by 10 or 20. The Bayesian estimator in Mplus uses Full Information Maximum Likelihood to account for missing data; however, our scores of SDQ use listwise deletion in that all items must have a response to be included and non-response is greater in total SDQ compared to subscales (see Supplementary Material Table 1). To date, frequentist approaches do not yet offer the same techniques for missing data; the Bayesian approach was selected given the flexible framework and ability to account for uncertainty in estimates.

Results

There were more boys in the sample (52%), most children had a normal birth weight (90%), and most had a gestational age above 36 weeks (~95%). The most common qualification among mothers was GCSE A* - C (or equivalent), and the most common family net income band was £10,400 - £20,800 (32%). The baseline demographics of the children in the MCS cohort at time-point 3 (N = 1,828) compared to the sample of mothers who had GP data available at the same time-point (N = 1,411) were very similar, see Supplementary Material Table 2.

Random Intercept Cross-lagged Panel Models

Five RI-CLPMs estimated the relationship between maternal mental health (MH) and total SDQ (Fig. 3), emotional problems (EP) (Fig. 4), conduct problems (CP) (Fig. 5), hyperactivity (HYP) and peer problems (PPR), adjusted for maternal qualifications and child sex. A positive coefficient

represents an increase in the predicted probability as the predictor increases, and a negative coefficient represents a decrease in the predicted probability as the predictor increases; 95% Credible Intervals (CI) are given in brackets. Throughout the models, maternal mental health (MH) had positive carry-over stability effects across time, which suggests that help-seeking behaviours, compared to their own norm, were likely to follow during the next period. Likewise, all types of child problems had positive carry-over stability effects, except for time-point 1.

Total Strengths and Difficulties Score

For cross-lagged effects, $SDQ_{Age\ 7}$ was associated with increased maternal mental health problems at $MH_{Age\ 11}$ (0.28, 95%CI 0.08, 0.45), see Fig. 3. The between-person level correlation showed a strong, positive association suggesting both had similar trait-like difficulties simultaneously (0.45, 95%CI 0.29, 0.64). The correlation between mother’s mental health problem and child SDQ cross-sectionally had

no associations. Child sex was not associated with maternal mental health (-0.03, 95%CI -0.16, 0.11), but girls were at a lower risk of problem behaviours (-0.27, 95%CI -0.41, -0.14). Higher maternal qualifications were associated with reduced risk for both maternal mental health (-0.19, 95%CI -0.26, -0.12) and child problem behaviours (-0.36, 95%CI -0.43, -0.29).

Emotional Problems

For cross-lagged effects, there was a positive association from $EP_{Age\ 7}$ to $MH_{Age\ 11}$ (0.22, 95%CI 0.05, 0.38), and then $MH_{Age\ 11}$ was positively associated with $EP_{Age\ 14}$ (0.18, 95%CI 0.01, 0.34); see Fig. 4. The between-person level correlation showed a strong, positive association suggesting both had similar trait-like difficulties simultaneously (0.32, 95%CI 0.15, 0.52). The correlation between maternal mental health problems and child emotional problems cross-sectionally showed narrowing positive credible intervals over time and associations were clearer at Age 11 (0.25,

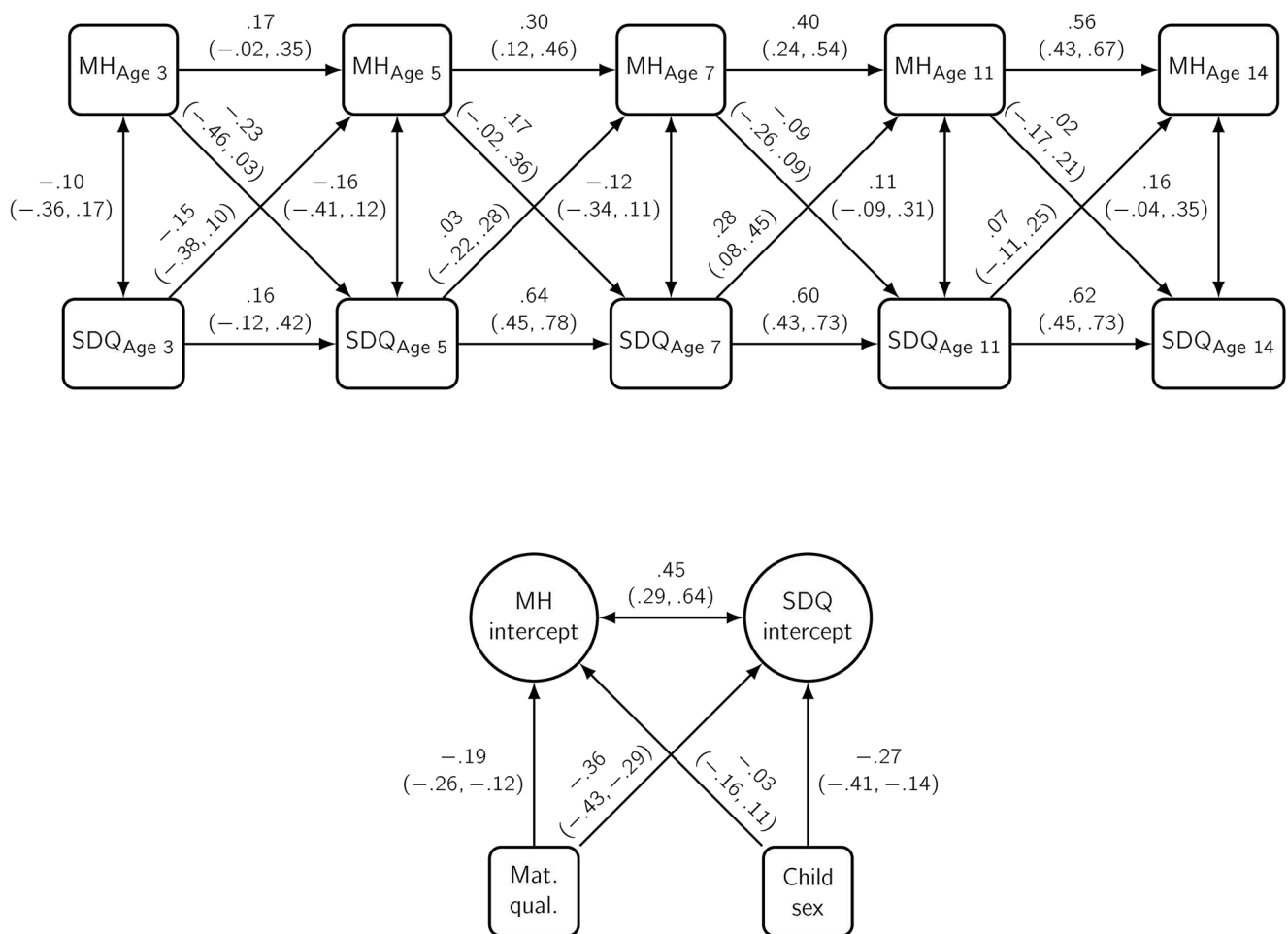

Fig. 3 Probit estimates with 95% credible intervals from a random intercept cross-lagged panel model of total Strengths and Difficulties Questionnaire (SDQ) score and maternal mental health (MH). *Adjusted for maternal qualifications and child sex (N = 1835)

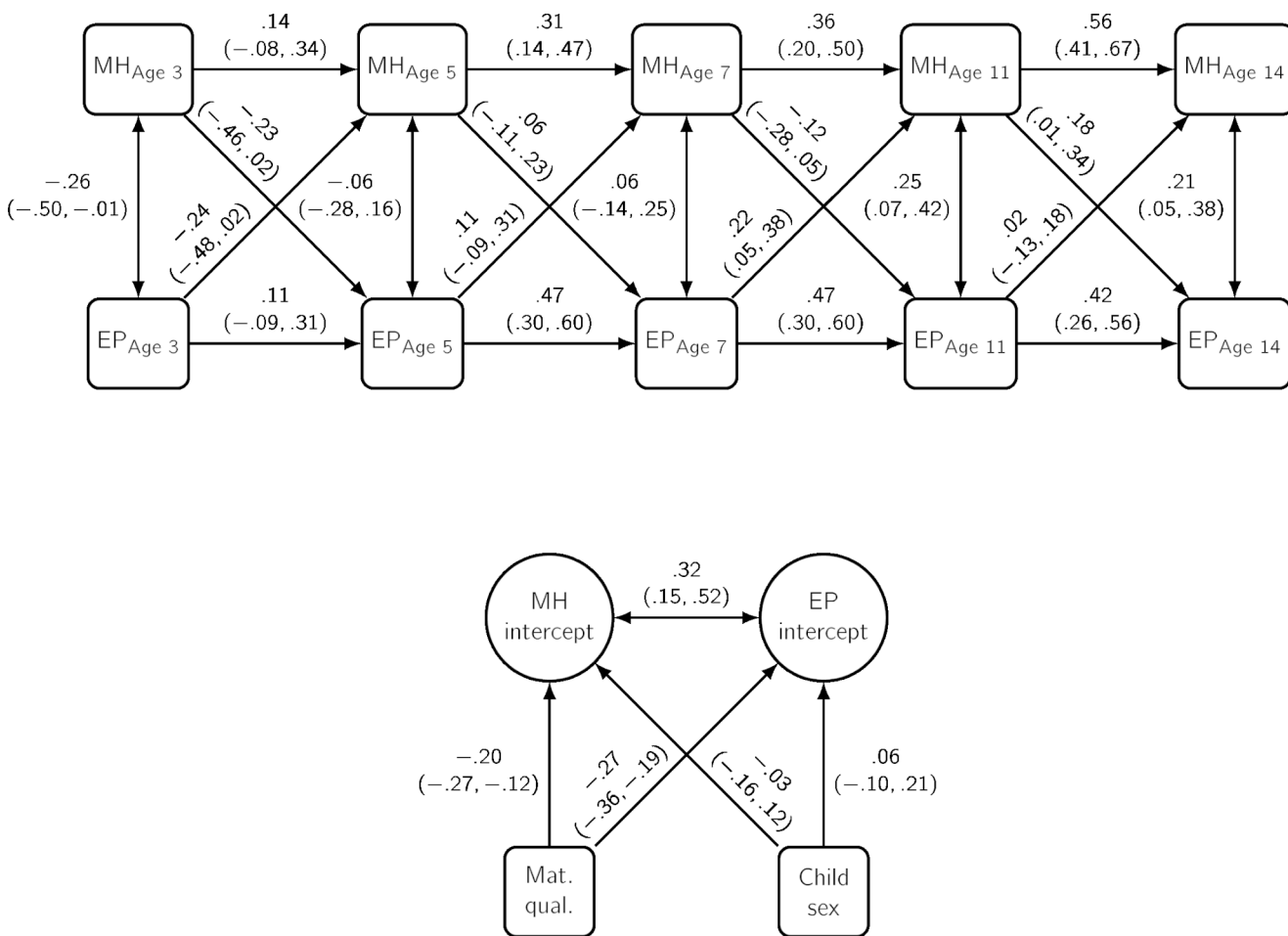

Fig. 4 Probit estimates with 95% credible intervals from a random intercept cross-lagged panel model of Emotional Problems (EP) and maternal mental health (MH). *Adjusted for maternal qualifications and child sex. (N = 1842)

95%CI 0.07, 0.42) and Age 14 (0.21, 95%CI 0.05, 0.38). Child sex was not associated with maternal mental health (-0.03, 95%CI -0.16, 0.12), or emotional problems (0.06, 95%CI -0.10, 0.21). Higher maternal qualifications were associated with reduced risk for both maternal mental health (-0.20, 95%CI -0.27, -0.12) and child emotional problems (-0.27, 95%CI -0.36, -0.19).

Conduct Problems

For cross-lagged effects, maternal mental health (MH) had wide credible intervals with no clear relationship with conduct problems (CP) (see Fig. 5). The between-person level correlation showed a strong, positive association suggesting both had similar trait-like difficulties simultaneously (0.31, 95%CI 0.17, 0.45). The correlation between maternal mental health and conduct problems cross-sectionally had no apparent relationship. Child sex was not associated with maternal mental health (-0.03, 95%CI -0.17, 0.12) but was strongly associated with conduct problems (-0.27, 95%CI

-0.39, -0.14). Higher maternal qualifications were associated with reduced risk for both maternal mental health (-0.19, 95%CI -0.26, -0.12) and child problems (-0.36, 95%CI -0.42, -0.30).

Hyperactivity

For cross-lagged effects, maternal mental health (MH) had wide credible intervals with no clear relationship with child hyperactivity (HYP). Likewise, hyperactivity had no clear relationship with maternal mental health. The between-person level correlation showed a strong, positive association suggesting both had similar trait-like difficulties simultaneously (0.33, 95%CI 0.20, 0.46). The correlation between maternal mental health problem and hyperactivity cross-sectionally had no association, aside from at Age 14, which was positive (0.26, 95%CI 0.08, 0.44). Child sex was not associated with maternal mental health (-0.02, 95%CI -0.16, 0.12), but girls were at a lower risk of hyperactivity (-0.45, 95%CI -0.57, -0.33). Higher maternal qualifications were

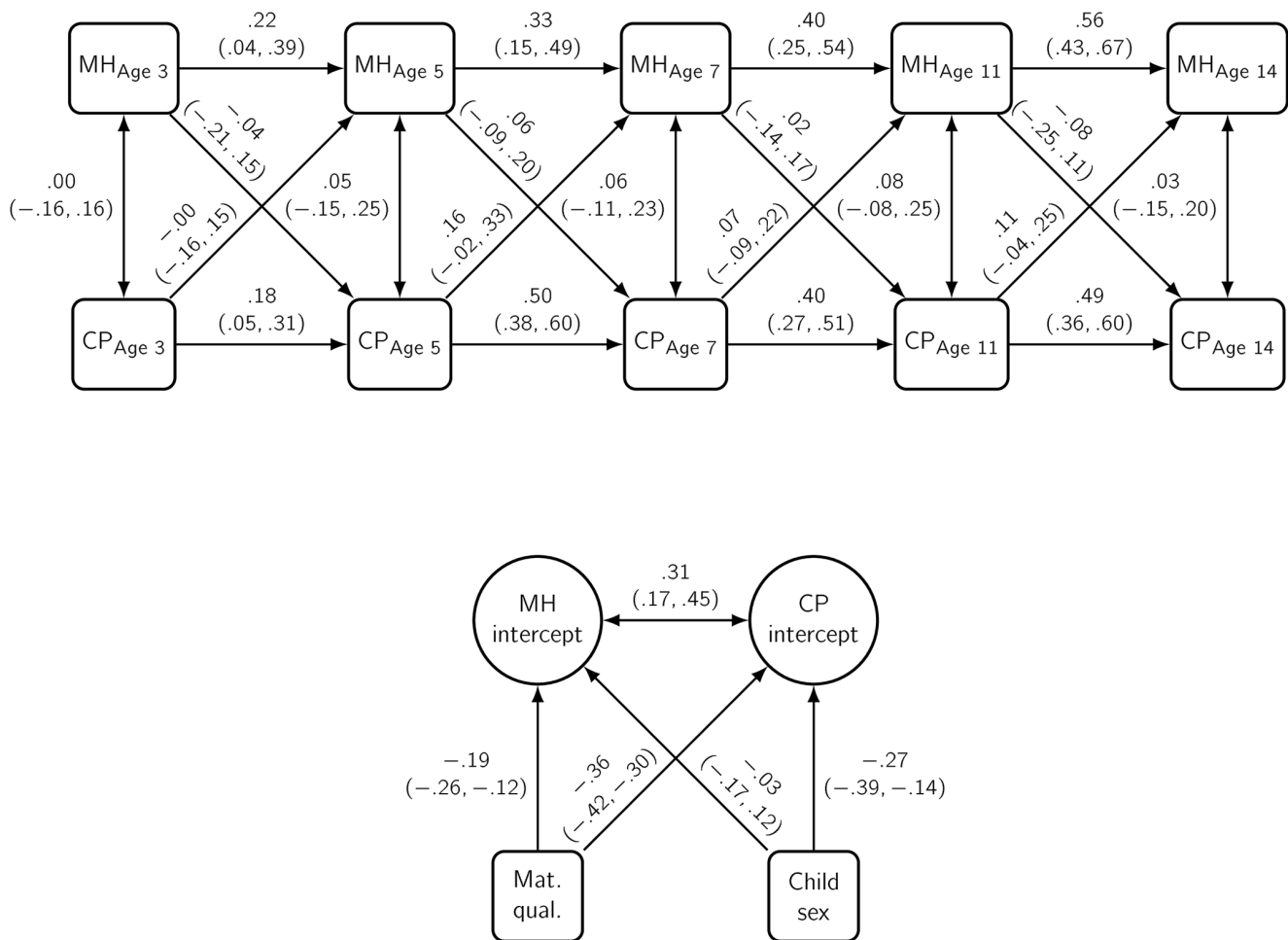

Fig. 5 Probit estimates with 95% credible intervals from a random intercept cross-lagged panel model of Conduct Problems (CP) and maternal mental health (MH). *Adjusted for maternal qualifications and child sex. (N=1842)

associated with reduced risk for both maternal mental health (-0.19, 95%CI -0.26, -0.12) and hyperactivity (-0.28, 95%CI -0.34, -0.22). See Supplementary Material Fig. 1.

Peer Problems

For cross-lagged effects, maternal mental health (MH) had wide credible intervals with no clear relationship with peer problems (PPR). However, PPR_{Age 7} had a positive association with MH_{Age 11} (0.25, 95%CI 0.09, 0.39); all other time points from PPR to MH showed no associations and wide credible intervals. The between-person level correlation showed a strong, positive association suggesting both had similar trait-like difficulties simultaneously (0.32, 95%CI 0.13, 0.50). The correlation between maternal mental health problem and peer problems cross-sectionally had a negative relationship in the first time-point (-0.26, 95%CI -0.47, -0.04), however, age 11 had a positive relationship (0.28, 95%CI 0.12, 0.44). Child sex was not associated with maternal mental health (-0.02, 95%CI -0.16, 0.12), but girls

were at a lower risk of peer problems (-0.23, 95%CI -0.39, -0.08). Higher maternal qualifications were associated with reduced risk for both maternal mental health (-0.19, 95%CI -0.26, -0.12) and peer problems (-0.33, 95%CI -0.42, -0.25). See Supplementary Material Fig. 2.

Discussion

In this study, we investigated the longitudinal association between maternal mental health problems and children's emotional, behavioural, hyperactivity, and peer problems. We found mixed evidence for bi-directional relationships between maternal mental health and child problem behaviours. Our findings may have implications for theory advancement and intervention strategies aimed at improving maternal mental health and children's problem behaviours.

Trait-like Associations (Between-person)

In support of hypothesis one, our research consistently showed strong between-person (trait-like) associations between maternal mental health and child problems, whereby mothers with mental health problems likely reported that their children had problem behaviours throughout childhood and into adolescence. We consistently found evidence for socioeconomic status (via early maternal education qualifications) being strongly associated with both maternal and child problems, in line with the general literature (Finegan et al., 2018; Letourneau et al., 2013; Marmot & Bell, 2012; Reiss, 2013). Given mothers with fewer resources are at a greater risk of mental health problems (depression and anxiety), which subsequently is associated with less desirable parenting practices and styles (Vreeland et al., 2019), it is plausible to advocate that mothers who are ‘doubly-disadvantaged’ should be a priority for support. Other studies have also referred to between-effects being in relation to lower sensitivity from the mother to the child (Murray et al., 1996), communication styles (Murray & Cooper, 1997), family conflict or monitoring (Van Loon et al., 2014) and genetic transmission.

We also found that boys were at a heightened risk of overall problems, including conduct, hyperactivity, and peer problems, mirroring findings by Maurice-Stam et al. (2018) and also Van Roy et al. (2006). Contrastingly, we did not find that emotional problems were higher for girls unlike other studies (Bøe et al., 2016; Van Roy et al., 2006). However, wider studies suggest that emotional problems in girls tend to have adolescent on-set which may explain our study’s lack of alignment (Martel, 2013; Murray et al., 2022; Rutter et al., 2003). In terms of hyperactivity, our findings generally align with boys having a greater prevalence than girls (Williamson & Johnston, 2015). However, ongoing research suggests that measures of ADHD could be biased towards symptoms which align more with boys’ experiences (Williamson & Johnston, 2015), with ongoing research on how to better identify girls’ symptoms and experiences (Young et al., 2020). In terms of the measurement performance longitudinally, Murray et al. (2022) found that the parent-reported SDQ items did not perform well as a latent variable at age three for males and females, which may explain why fewer associations were observed at this age; this study uses the same data, but we use the Welsh sub-group to derive estimates.

As a result, given both the mother and child experienced problems, we echo Ranøyen et al. (2015) that interventions should be family-based to both evaluate and support all members of the household, as demonstrated in an intervention by Poole et al. (2018). However, support strategies should be aware of both the socioeconomic vulnerability

of families who may require economic support, and sex differences, with boys being at a higher risk for problem behaviour(s).

Carry-over Stability Effects (Within-person)

In support of hypothesis two, all models showed consistent within-person carry-over stability effects, suggesting earlier child problems increased the likelihood of later problems, congruent with the literature on child development (Flouri et al., 2015; Sifaki et al., 2021) and other bi-directional studies (Belsky, 1984; Speyer et al., 2022; Xerxa et al., 2021). Carry-over stability effects became stronger over time for maternal mental health, with associations increasing in size at each time-point, whereas associations for child problems were more stable, but earlier time points were weaker, suggesting age five years may be a critical point for the development of problems. Our within-person results are in line with previous research on maternal mental health in earlier post-partum stages (Horowitz & Goodman, 2004) and child behaviour problems (Gross et al., 2008). Furthermore, our results for child within-associations closely resemble results found in Speyer et al. (2022), which is expected given they used the same dataset but this was UK-wide, not the Wales sub-sample like our study.

Bi-directional Associations Over Time

We found mixed results for bi-directional associations, with the differences in findings depending on the problem behaviour outcome of the child. To summarise, child emotional problems appeared to be the only outcome which had some evidence of bi-directional associations occurring in mid-childhood to mid-adolescence (child aged 7–14 years). Our findings regarding children’s emotional problems are supported by the transactional theory literature (Bell, 1968, 1971; Belsky, 1984; Sameroff, 1975), the premise that children are influenced by their environment while simultaneously responding to the environment they are in (Cicchetti & Toth, 1997). As discussed by Speyer et al. (2022), maternal mental health problems can lead to the use of parenting behaviours and styles that can subsequently lead to child problems, which then cycle back to the mother through the child’s behaviour. Research has previously evidenced the reciprocal relationships in the domain of child behaviour, in terms of parental depression (Gross et al., 2008) or mental health (Speyer et al., 2022; Xerxa et al., 2021), but also parenting stress which has been discussed as an antecedent and a consequence of child behaviour problems (Neece et al., 2012; Vallotton et al., 2016).

Given that child emotional problems show bi-directional associations in both directions, i.e., child problems

associating with maternal problems and then vice-versa, our findings support the theory that children and their mother mutually affect one another, eliciting specific responses from each other (Sameroff, 1975; Xerxa et al., 2021). We see that child emotional problems at age 7 years were initially associated with maternal mental health, and reciprocally, maternal mental health then was associated with child emotional problems at age 14 years. Speyer et al. (2022) also found a reciprocal relationship for emotional problems, however, this occurred earlier, started with the mothers' association first, and only occurred for boys. Consequently, we observe that reciprocal relationships are likely to exist but the directions in which they occur require further investigation with a range of samples and measurements to derive comparisons.

We also find that the timing of these associations is of interest. Mid to late stages of childhood and early adolescence held reciprocal associations rather than in the early years. Our study does not have a further time-point to investigate later adolescence at the time of writing, but in Speyer et al. (2022) which used similar methods and data, associations were continued to age 17 years. While it is often the case that the life phase of adolescence is depicted by the ability to simultaneously become influenced and influence peers more so than parents (Brechwald & Prinstein, 2011; Collins & Laursen, 2004), our findings and other studies still find an association in adolescence. This is perhaps due to the parent-child relationship not ceasing but changing whereby parental closeness often becomes second to friends (Collins & Laursen, 2004; Laursen & Williams, 1997). Other studies have also identified reciprocal relationships in the area of emotional problems at ages 7 to 14 years (Serbin et al., 2015; Speyer et al., 2022; Xerxa et al., 2021). Hence, our study confirms that bi-directional research should consider the childhood and adolescent life phase as timings appear to be important and may change.

In terms of the other problem behaviour areas, we did not find bi-directional associations for child conduct problems, and we found little to no evidence for bi-directional associations in the areas of child hyperactivity and peer problems. We discuss each child's problem behaviour outcome in relation to wider theory, literature, and practice below.

Children's Overall Problems and Maternal Mental Health

For overall problems (total SDQ score), we found some support for hypothesis four, that child overall problems were positively associated with maternal mental health problems when the child was 7 – 11 years old. All other associations intersected the null, suggesting uncertainty in estimates. Child overall problem behaviour in this study represents a constellation of behaviours (emotional, conduct,

hyperactivity, and peer problems) where levels are not 'typical' across these items. It is well-known that parenthood is a substantial life change which can be stressful, particularly if children are diagnosed with physical or mental disabilities (Hayes & Watson, 2013). Developmental transition periods such as middle childhood can be of particular importance for child driven-effects (Blume et al., 2022; Yan & Ansari, 2016). Jiang et al. (2022) found that parenting stress was largely predicted by child problem behaviours, however, there was a reciprocal association in early childhood, with internalising behaviour being specifically larger in effect size and more prevalent over time compared to externalising in disadvantaged families (a similar cohort to our study in some aspects). Dubois-Comtois et al. (2013) explain that aspects such as the mother-child relationship can be key for promoting child adaptation, along with secure attachment styles; children who had a controlling-punitive attachment to their caregivers were more likely to show socio-emotional difficulties. Hence, to understand the pathways of child problem behaviours and maternal mental health further, research must explore the multiplicity of the parent-child relationship including factors such as attachment, parenting, the family environment, and social support.

Children's Emotional Problems and Maternal Mental Health

We found that children's emotional problems at age 7 years were positively associated with maternal mental health problems when the child was aged 11 years. Reciprocally, maternal mental health problems when the child was 11 years were positively associated with child emotional problems at age 14. While it is not clear why emotional problems were elevated at age 7 for children, it appears that they may disrupt maternal mental health, which then later reinforces emotional problems, which builds on the current evidence base (Ranøyen et al., 2015; Speyer et al., 2022; Turney, 2012; Xerxa et al., 2021) and transactional theory (Bell, 1968, 1971; Belsky, 1984; Sameroff, 2009).

In terms of explanations, an insecure attachment was identified as a mechanism between maternal mental health and child internalising symptoms in a meta-analysis (Spruit et al., 2020); a moderate effect size was found $r=.31$ from 123 samples. Secure attachment is considered met when a child views their parent as a 'secure base' alleviating fear, stress and worry (Bowlby, 2012); mothers with symptoms of depression are at a higher risk for insecure attachment, which is related to the child having an increased risk of dysfunctional cognitions about the self and chronic stress (due to a lack of a secure base for alleviation) (Spruit et al., 2020). In a transactional sense, it could be argued that depressive symptoms not only may change behaviour, (i.e., compromised parenting behaviours (Vreeland et al., 2019)) but also

how emotions are viewed and felt by the parent (positive affect) (Field et al., 1988). This may lead to the child developing similar behaviours that could be both environmental and genotype-specific (Hyde et al., 2016), which then may reinforce the mother's emotional climate and behaviours, essentially curating a cycle.

Children's Conduct Problems and Maternal Mental Health

We found no evidence that maternal mental health problems were associated with child conduct problems. Our study's lack of alignment with other research was not expected. Particularly given other studies have suggested a bi-directional link between parental depressive symptoms and child externalising behaviour (Gross et al., 2008), and the coercive family process model describes how detrimental family interactions can initiate and maintain behavioural problems in children (Patterson, 2002b). Gross et al. (2008) found strong evidence for bi-directional relationships whereby both the mother and child increased the risk of problem behaviours or depressive symptoms across two reports or raters. The difference may be related to administrative data being used which can sometimes signify a more serious illness, or be biased toward those who can identify a problem or seek help (Davis et al., 2016), whereas Gross et al. (2008) used continuous self-reported measures which have more variability and do not depend on participants attending healthcare providers.

Children's Hyperactivity and Maternal Mental Health

We found no evidence that hyperactivity and maternal mental health problems were associated. Still, we found a cross-sectional correlation at age 14 years, which may be due to the increased demand on the parent as the child becomes more autonomous. As discussed, providing care for a child who has hyperactivity can place additional demands and mental challenges on the parent (Johnston & Mash, 2001), which could become a mental health problem. Unlike our study, Breaux and Harvey (2019) found bi-directional associations between child ADHD symptoms and maternal depression. They theorise that this association is explained by mechanisms of parenting and family functioning, whereby increased ADHD symptoms placed additional demands on the parent, and a potential response was negative parenting practices (Barkley et al., 1991). However, in this study we did not find evidence of this, which may be attributable to (1) the use of administrative data, or (2) the focus on hyperactivity than specific ADHD diagnoses, which may capture more demanding behaviour.

Children's Peer Problems and Maternal Mental Health

We found no association between maternal mental health and peer problems over time, but an association between peer problems at age 7 years and maternal mental health problems when the child was 11 years old. These findings may allude to increased pressure on the parent when the child's social skills are more evident, and while studies have suggested it occurring in the opposite direction (Waerden et al., 2015), other researchers have found evidence of reciprocal relationships. For instance, Sifaki et al. (2021) used a cross-lagged panel model and found bi-directional relationships between paternal distress and peer problems. They theorise that peer victimisation or bullying could lead to feelings of shortcoming as a parent, or a source for further concern (Sifaki et al., 2021). Moreover, our theoretical thinking resides in that caregivers with greater depressive or anxiety symptoms are more likely to use parenting styles or behaviours which are considered less effective for child development in some cultural contexts. Yamagata et al. (2013) found bi-directional effects between parenting and peer problems in childhood; mechanisms in parental strain or behaviours may explain the association found in this study, however, bi-directional associations were not identified over time. As such, there may be critical points in childhood or specific areas of emotional mood rather than mental illness which require further investigation.

Strengths and Limitations

Our study benefits from several strengths, specifically the linkage of rich, detailed cohort data with routinely collected data over 13 years. Moreover, our method allowed for the separating of within and between-person effects to isolate bi-directional associations and benefits from a powerful new Bayesian approach. However, we could not access data on prenatal maternal mental health, despite research suggesting that it is associated with long-term development outcomes in children via elevated hormones and stress (Lupien et al., 2009; Welberg & Seckl, 2001). Second, we recognise that our study may be liable to 'shared variance' as discussed by Xerxa et al. (2021). Shared variance is a form of information bias where one or more participants reports on multiple aspects of the study, for example, a mother reporting on their own mental health and then their child's (Xerxa et al., 2021). Collishaw et al. (2009) found that all correlates of child mental health were related differently to parent, teacher and child ratings, with parent-ratings of both their functioning and child functioning being the most strongly correlated. Indeed, it is known that mothers experiencing mental health illness may report higher child behavioural problems, whereas mothers not experiencing mental illness

tend not to report child behavioural problems as much (Najman et al., 2000; Ringoot et al., 2015). In addition, if an external factor influences both the rating of the mother and child this can also affect the results (Xerxa et al., 2021). While we use administrative measures of mothers' mental health symptoms, treatment and diagnoses, the child behaviours are largely reported by the mother whose rating may be affected by their own symptoms. Hence, further studies should consider a multitude of reporting (administrative and self) by various participants (partners, teachers, practitioners, and children themselves) to fully understand the consequences of shared method variance.

Third, by not including fathers or partners in this study, it is not possible to adjust for potential areas of strain or support. In addition, we also did not test for possible mediators or mechanisms in this research, so cannot empirically determine this in our study. Fifth, we are reliant on individuals accessing healthcare systems, reporting problems and outcomes being correctly coded by GPs, so our figures may be underestimated. Moreover, our sample over-represents economically disadvantaged groups, who are more likely to experience mental health problems (Reiss, 2013). Our study is likely to be more representative of these groups, rather than the total population, or families with more resources (i.e., higher socioeconomic status). Lastly, healthcare utilisation is more likely to depict feelings of 'readiness' towards receiving treatment which differs from self-reported mood.

Conclusion

Overall, our study using linked survey and administrative data found mixed evidence to support bi-directional theories of development (Bell, 1968, 1971). Child emotional problems had bi-directional associations in mid to late childhood, whereas overall behavioural problems and peer problems were associated only in the direction from child problems to maternal mental health. On the other hand, no cross-lagged associations were found for conduct problems or hyperactivity. However, all models had strong between-person effects suggesting other aspects, such as socioeconomic status, were largely explanatory for the relationship between maternal mental health and child problems. We found that lower socioeconomic groups were at a greater risk for both maternal mental health problems and child problems, and boys were particularly at risk for all domains except emotional problems. Therefore, we strongly encourage policymakers to provide family-based support for caregivers and children experiencing difficulties in terms of mental health, child behaviours or parenting, which considers the economic vulnerability that some families may experience.

Supplementary Information The online version contains supplementary material available at <https://doi.org/10.1007/s10802-023-01086-5>.

Acknowledgements This study makes use of anonymised data held in the Secure Anonymised Information Linkage (SAIL) Databank. This work uses data provided by patients and collected by the NHS as part of their care and support. We would also like to acknowledge all data providers who make anonymised data available for research. We are grateful to all the participants, fieldworkers, and Millennium Cohort Study team for providing data. We are equally grateful to Mplus for providing insight on our analytical procedure.

Author Contributions Conceptualisation of the study was conducted by EL, SB, AA, RF, LG, CT, and KH. The methodology was determined and reviewed by EL, SB, SMK, AA, RF, LG, CT, KH, RKO, RJ, and JH. EL, SB, SMK and RKO conducted and reviewed the analysis. EL was responsible for writing the first draft, with large contributions from SMK. All authors commented and reviewed the paper at multiple stages with suggestions for improvements or changes.

Funding This work was supported by Health Data Research UK, which receives its funding from HDR UK Ltd (HDR-9006) funded by the UK Medical Research Council, Engineering and Physical Sciences Research Council, Economic and Social Research Council, Department of Health and Social Care (England), Chief Scientist Office of the Scottish Government Health and Social Care Directorates, Health and Social Care Research and Development Division (Welsh Government), Public Health Agency (Northern Ireland), British Heart Foundation (BHF) and the Wellcome Trust. This work was supported by the ADR Wales programme of work. The ADR Wales programme of work is aligned to the priority themes as identified in the Welsh Government's national strategy: Prosperity for All. ADR Wales brings together data science experts at Swansea University Medical School, staff from the Wales Institute of Social and Economic Research and Data (WISERD) at Cardiff University and specialist teams within the Welsh Government to develop new evidence which supports Prosperity for All by using the SAIL Databank at Swansea University, to link and analyse anonymised data. ADR Wales is part of the Economic and Social Research Council (part of UK Research and Innovation) funded ADR UK (grant ES/S007393/1).

Data Availability The data used in this study are available in the SAIL Databank at Swansea University, Swansea, UK, but as restrictions apply, they are not publicly available. All proposals to use SAIL data are subject to review by an independent Information Governance Review Panel (IGRP). Before any data can be accessed, approval must be given by the IGRP. The IGRP gives careful consideration to each project to ensure proper and appropriate use of SAIL data. When access has been granted, it is gained through a privacy protecting safe haven and remote access system referred to as the SAIL Gateway. SAIL has established an application process to be followed by anyone who would like to access data via SAIL at <https://www.saildatabank.com/application-process>. All research conducted has been completed under the permission and approval of the SAIL independent IGRP project number 1015.

Declarations

Conflicts of Interest RKO is a member of the National Institute for Health and Care Excellence (NICE) Technology Appraisal Committee, member of the NICE Decision Support Unit (DSU), and associate member of the NICE Technical Support Unit (TSU). She has served as a paid consultant to the pharmaceutical industry, providing unrelated

methodological advice. She reports teaching fees from the Association of British Pharmaceutical Industry (ABPI) and the University of Bristol.

Open Access This article is licensed under a Creative Commons Attribution 4.0 International License, which permits use, sharing, adaptation, distribution and reproduction in any medium or format, as long as you give appropriate credit to the original author(s) and the source, provide a link to the Creative Commons licence, and indicate if changes were made. The images or other third party material in this article are included in the article's Creative Commons licence, unless indicated otherwise in a credit line to the material. If material is not included in the article's Creative Commons licence and your intended use is not permitted by statutory regulation or exceeds the permitted use, you will need to obtain permission directly from the copyright holder. To view a copy of this licence, visit <http://creativecommons.org/licenses/by/4.0/>.

References

- Acri, M. C., Bornheimer, L. A., Jessell, L., Chomanczuk, A. H., Adler, J. G., Gopalan, G., & McKay, M. M. (2017). The intersection of extreme poverty and familial mental health in the United States. *Social Work in Mental Health, 15*(6), 677–689. <https://doi.org/10.1080/15332985.2017.1319893>.
- Asparouhov, T., & Muthén, B. (2021). *Residual Structural Equation Models*. 84.
- Asparouhov, T., & Muthén, B. (2021). Advances in bayesian model fit evaluation for structural equation models. *Structural Equation Modeling: A Multidisciplinary Journal, 28*(1), 1–14. <https://doi.org/10.1080/10705511.2020.1764360>.
- Barkley, R. A., Fischer, M., Edelbrock, C., & Smallish, L. (1991). The adolescent outcome of hyperactive children diagnosed by Research Criteria—III. Mother–child interactions, family conflicts and maternal psychopathology. *Journal of Child Psychology and Psychiatry, 32*(2), 233–255. <https://doi.org/10.1111/j.1469-7610.1991.tb00304.x>.
- Bell, R. Q. (1968). A reinterpretation of the direction of effects in studies of socialization. *Psychological Review, 75*(2), 81. <https://doi.org/10.1037/h0025583>.
- Bell, R. Q. (1971). Stimulus control of parent or caretaker behavior by offspring. *Developmental Psychology, 4*(1), 63–72. <https://doi.org/10.1037/h0030374>.
- Belsky, J. (1984). The determinants of parenting: A process model. *Child Development, 55*(1), 83–96. <https://doi.org/10.2307/1129836>.
- Blume, J., Park, S., Cox, M., & Mastergeorge, A. M. (2022). Explicating child-driven patterns of parent-child responsivity in Fragile families: A Longitudinal Approach. *Frontiers in Pediatrics, 10*, 813486. <https://doi.org/10.3389/fped.2022.813486>.
- Bøe, T., Hysing, M., Skogen, J. C., & Breivik, K. (2016). The Strengths and Difficulties Questionnaire (SDQ): Factor structure and gender equivalence in norwegian adolescents. *PLOS ONE, 11*(5), e0152202. <https://doi.org/10.1371/journal.pone.0152202>.
- Borre, A., & Kliewer, W. (2014). Parental strain, mental health problems, and parenting practices: A longitudinal study. *Personality and Individual Differences, 68*, 93–97. <https://doi.org/10.1016/j.paid.2014.04.014>.
- Bourdieu, P. (1985). The forms of capital. In J. G. Richardson (Ed.), *Handbook of theory and research for the sociology of education*. Incorporated: Greenwood Publishing Group.
- Bowlby, J. (2012). *A secure base*. Routledge.
- Breaux, R. P., & Harvey, E. A. (2019). A longitudinal study of the relation between Family Functioning and Preschool ADHD symptoms. *Journal of Clinical Child & Adolescent Psychology, 48*(5), 749–764. <https://doi.org/10.1080/15374416.2018.1437737>.
- Brechwald, W. A., & Prinstein, M. J. (2011). Beyond Homophily: A decade of advances in understanding peer influence processes. *Journal of Research on Adolescence, 21*(1), 166–179. <https://doi.org/10.1111/j.1532-7795.2010.00721.x>.
- Bronfenbrenner, U. (1979). *The ecology of human development*. Harvard University Press.
- Cicchetti, D., Toth, S. L. Transactional ecological systems in developmental psychopathology. In S. S. Luthar, J. A. Burack, J. R. Weisz, D. Cicchetti, P. of S. D. P. and D. of the M. Y. S. T. J. A., & Burack (1997). (Eds.), *Developmental Psychopathology: Perspectives on Adjustment, Risk, and Disorder*. Cambridge University Press.
- Collins, A. W., & Laursen, B. (2004). Parent-adolescent Relationships and Influences. In R. M. Lerner, & L. Steinberg (Eds.), *Handbook of adolescent psychology* (2nd ed.). John Wiley & Sons.
- Collishaw, S., Goodman, R., Ford, T., Rabe-Hesketh, S., & Pickles, A. (2009). How far are associations between child, family and community factors and child psychopathology informant-specific and informant-general? *Journal of Child Psychology and Psychiatry and Allied Disciplines, 50*(5), 571–580. <https://doi.org/10.1111/j.1469-7610.2008.02026.x>.
- Connelly, R., & Platt, L. (2014). Cohort profile: Uk millennium cohort study (mcs). *International Journal of Epidemiology, 43*(6), 1719–1725. <https://doi.org/10.1093/ije/dyu001>.
- Cortés-García, L., Wichstrøm, L., Viddal, K. R., & Senra, C. (2019). Prospective bidirectional Associations between attachment and depressive symptoms from Middle Childhood to Adolescence. *Journal of Youth and Adolescence, 48*(11), 2099–2113. <https://doi.org/10.1007/s10964-019-01081-4>.
- Cutrona, C. E., & Troutman, B. R. (1986). Social support, infant temperament, and parenting Self-Efficacy: A Mediatonal Model of Postpartum Depression. *Child Development, 57*(6), 1507–1518. <https://doi.org/10.2307/1130428>.
- Davis, K. A. S., Sudlow, C. L. M., & Hotopf, M. (2016). Can mental health diagnoses in administrative data be used for research? A systematic review of the accuracy of routinely collected diagnoses. *Bmc Psychiatry, 16*(1), 263. <https://doi.org/10.1186/s12888-016-0963-x>.
- Dubois-Comtois, K., Moss, E., Cyr, C., & Pascuzzo, K. (2013). Behavior problems in Middle Childhood: The predictive role of maternal distress, child attachment, and mother-child interactions. *Journal of Abnormal Child Psychology, 41*(8), 1311–1324. <https://doi.org/10.1007/s10802-013-9764-6>.
- Field, T., Healy, B., Goldstein, S., Perry, S., Bendell, D., Schanberg, S., Zimmerman, E. A., & Kuhn, C. (1988). Infants of depressed mothers show ‘Depressed’ behavior even with nondepressed adults. *Child Development, 59*(6), 1569–1579. <https://doi.org/10.2307/1130671>.
- Finegan, M., Firth, N., Wojnarowski, C., & Delgadillo, J. (2018). Associations between socioeconomic status and psychological therapy outcomes: A systematic review and meta-analysis. *Depression and Anxiety, 35*(6), 560–573. <https://doi.org/10.1002/da.22765>.
- Fledderjohann, J., Erlam, J., Knowles, B., & Broadhurst, K. (2021). Mental health and care needs of british children and young people aged 6–17. *Children and Youth Services Review, 126*, 106033. <https://doi.org/10.1016/j.chilyouth.2021.106033>.
- Flouri, E., Narayanan, M. K., & Midouhas, E. (2015). The cross-lagged relationship between father absence and child problem behaviour in the early years. *Child: Care Health and Development, 41*(6), 1090–1097. <https://doi.org/10.1111/cch.12236>.
- Galbally, M., & Lewis, A. J. (2017). Depression and parenting: The need for improved intervention models. *Current Opinion in Psychology, 15*, 61–65. <https://doi.org/10.1016/j.copsyc.2017.02.008>.

- Goodman, R. (2001). Psychometric Properties of the Strengths and Difficulties Questionnaire. *Journal of the American Academy of Child & Adolescent Psychiatry*, 40(11), 1337–1345. <https://doi.org/10.1097/00004583-200111000-00015>.
- Goodman, S. H., Rouse, M. H., Connell, A. M., Broth, M. R., Hall, C. M., & Heyward, D. (2011). Maternal depression and child psychopathology: A Meta-Analytic Review. *Clinical Child and Family Psychology Review*, 14(1), 1–27. <https://doi.org/10.1007/s10567-010-0080-1>.
- Gross, H. E., Shaw, D. S., & Moilanen, K. L. (2008). Reciprocal associations between boys' externalizing problems and mothers' depressive symptoms. *Journal of Abnormal Child Psychology*, 36(5), 693–709. <https://doi.org/10.1007/s10802-008-9224-x>.
- Haine-Schlagel, R., Martinez, J. I., Roesch, S. C., Bustos, C. E., & Janicki, C. (2018). Randomized Trial of the parent and caregiver active participation toolkit for child Mental Health treatment. *Journal of Clinical Child and Adolescent Psychology: The Official Journal for the Society of Clinical Child and Adolescent Psychology American Psychological Association Division*, 53(sup1), S150–S160. <https://doi.org/10.1080/15374416.2016.1183497.47>.
- Hamaker, E. L., Kuiper, R. M., & Grasman, R. P. P. P. (2015). A critique of the cross-lagged panel model. *Psychological Methods*, 20(1), 102–116. <https://doi.org/10.1037/a0038889>.
- Hayes, S. A., & Watson, S. L. (2013). The impact of parenting stress: A Meta-analysis of studies comparing the experience of parenting stress in parents of children with and without Autism Spectrum Disorder. *Journal of Autism and Developmental Disorders*, 43(3), 629–642. <https://doi.org/10.1007/s10803-012-1604-y>.
- Hickey, E. J., Bolt, D., Rodriguez, G., & Hartley, S. L. (2020). Bidirectional relations between parent warmth and criticism and the symptoms and behavior problems of children with autism. *Journal of Abnormal Child Psychology*, 48(6), 865–879. <https://doi.org/10.1007/s10802-020-00628-5>.
- Horowitz, J. A., & Goodman, J. (2004). A longitudinal study of maternal Postpartum Depression symptoms. *Research and Theory for Nursing Practice*, 18(2/3), 149–163.
- Hunt, M., Auriemma, J., & Cashaw, A. C. A. (2003). Self-Report Bias and Underreporting of Depression on the BDI-II. *Journal of Personality Assessment*, 80(1), 26–30. https://doi.org/10.1207/S15327752JPA8001_10.
- Hyde, C. L., Nagle, M. W., Tian, C., Chen, X., Paciga, S. A., Wendland, J. R., Tung, J. Y., Hinds, D. A., Perlis, R. H., & Winslow, A. R. (2016). Identification of 15 genetic loci associated with risk of major depression in individuals of European descent. *Nature Genetics*, 48(9), <https://doi.org/10.1038/ng.3623>. Article 9.
- Jiang, Q., Wang, D., Yang, Z., & Choi, J. K. (2022). Bidirectional relationships between parenting stress and child behavior problems in multi-stressed, single-mother families: A cross-lagged panel model. *Family Process*, (n/a), e12796. <https://doi.org/10.1111/famp.12796>
- John, A., McGregor, J., Fone, D., Dunstan, F., Cornish, R., Lyons, R. A., & Lloyd, K. R. (2016). Case-finding for common mental disorders of anxiety and depression in primary care: An external validation of routinely collected data. *BMC Medical Informatics and Decision Making*, 16(1), 35. <https://doi.org/10.1186/s12911-016-0274-7>.
- Johnston, C., & Mash, E. J. (2001). Families of children with Attention-Deficit/Hyperactivity disorder: Review and recommendations for Future Research. *Clinical Child and Family Psychology Review*, 4(3), 183–207. <https://doi.org/10.1023/A:1017592030434>.
- Kingston, D., & Tough, S. (2014). Prenatal and postnatal maternal Mental Health and School-Age Child Development: A systematic review. *Maternal and Child Health Journal*, 18(7), 1728–1741. <https://doi.org/10.1007/s10995-013-1418-3>.
- Kristensen, S. M., Danielsen, A. G., Jenø, L. M., Larsen, T. M. B., & Urke, H. B. (2021). The Within-Person Effect of Psychological Distress on Social Self-Efficacy: A Random Intercept Cross-Lagged Panel Model. *Journal of Research on Adolescence*, jora.12701. <https://doi.org/10.1111/jora.12701>
- Laursen, B., & Williams, V. A. (1997). Perceptions of interdependence and closeness in family and peer relationships among adolescents with and without romantic partners. *New Directions for Child Development*, 78, 3–20. <https://doi.org/10.1002/cd.23219977803>.
- Letourneau, N. L., Duffett-Leger, L., Levac, L., Watson, B., & Young-Morris, C. (2013). Socioeconomic status and child development: A Meta-analysis. *Journal of Emotional and Behavioral Disorders*, 21(3), 211–224. <https://doi.org/10.1177/1063426611421007>.
- Lupien, S. J., McEwen, B. S., Gunnar, M. R., & Heim, C. (2009). Effects of stress throughout the lifespan on the brain, behaviour and cognition. *Nature Reviews Neuroscience*, 10(6), 434–445. <https://doi.org/10.1038/nrn2639>.
- Marmot, M., & Bell, R. (2012). Fair society, healthy lives. *Public Health*, 126, S4–S10. <https://doi.org/10.1016/j.puhe.2012.05.014>.
- Martel, M. M. (2013). Sexual selection and sex differences in the prevalence of childhood externalizing and adolescent internalizing disorders. *Psychological Bulletin*, 139, 1221–1259. <https://doi.org/10.1037/a0032247>.
- Maurice-Stam, H., Haverman, L., Splinter, A., van Oers, H. A., Schepers, S. A., & Grootenhuis, M. A. (2018). Dutch norms for the Strengths and Difficulties Questionnaire (SDQ) – parent form for children aged 2–18 years. *Health and Quality of Life Outcomes*, 16(1), 123. <https://doi.org/10.1186/s12955-018-0948-1>.
- Mensah, F. K., & Kiernan, K. E. (2010). Parents' mental health and children's cognitive and social development. *Social Psychiatry and Psychiatric Epidemiology*, 45(11), 1023–1035. <https://doi.org/10.1007/s00127-009-0137-y>.
- Middleton, M., Scott, S. L., & Renk, K. (2009). Parental depression, parenting behaviours, and behaviour problems in young children. *Infant and Child Development*, 18(4), 323–336. <https://doi.org/10.1002/icd.598>.
- Mund, M., & Nestler, S. (2019). Beyond the Cross-Lagged Panel Model: Next-generation statistical tools for analyzing interdependencies across the life course. *Advances in Life Course Research*, 41, 100249. <https://doi.org/10.1016/j.alcr.2018.10.002>.
- Murray, L., & Cooper, P. (1997). Effects of postnatal depression on infant development. *Archives of Disease in Childhood*, 77(2), 99–101.
- Murray, L., Fiori-Cowley, A., Hooper, R., & Cooper, P. (1996). The impact of postnatal depression and associated adversity on early mother-infant interactions and later infant outcome. *Child Development*, 67(5), 2512–2526.
- Murray, A. L., Speyer, L. G., Hall, H. A., Valdebenito, S., & Hughes, C. (2022). *A Longitudinal and Gender Invariance Analysis of the Strengths and Difficulties Questionnaire Across Ages 3, 5, 7, 11, 14, and 17 in a Large U.K.-Representative Sample*. 29(6), 1248–1261.
- Muthén, B. (2010). Bayesian analysis in Mplus: A brief introduction. *Mplus*, 92.
- Muthén, L. (2017). In B. Muthén (Ed.), *Mplus: User's guide* (Eighth Edition vol.). Muthén & Muthén. https://www.statmodel.com/download/usersguide/MplusUserGuideVer_8.pdf.
- Najman, J. M., Williams, G. M., Nikles, J., Spence, S., Bor, W., O'Callaghan, M., Le, B. R. O. C. Q. U. E., R., & Andersen, M. J. (2000). Mothers' Mental illness and child behavior problems: Cause-Effect Association or Observation Bias? *Journal of the American Academy of Child & Adolescent Psychiatry*, 39(5), 592–602. <https://doi.org/10.1097/00004583-200005000-00013>.
- Neece, C. L., Green, S. A., & Baker, B. L. (2012). Parenting stress and child behavior problems: A transactional relationship across Time.

- American Journal on Intellectual and Developmental Disabilities*, 117(1), 48–66. <https://doi.org/10.1352/1944-7558-117.1.48>.
- Nelson, D. R., Hammen, C., Brennan, P. A., & Ullman, J. B. (2003). The impact of maternal depression on adolescent adjustment: The role of expressed emotion. *Journal of Consulting and Clinical Psychology*, 71(5), 935–944. <https://doi.org/10.1037/0022-006X.71.5.935>.
- O'Donnell, S., Vanderloo, S., McRae, L., Onysko, J., Patten, S. B., & Pelletier, L. (2016). Comparison of the estimated prevalence of mood and/or anxiety disorders in Canada between self-report and administrative data. *Epidemiology and Psychiatric Sciences*, 25(4), 360–369. <https://doi.org/10.1017/S2045796015000463>.
- Patterson, G. R. (1982). *Coercive family process* (3 vol.). Castalia publishing company.
- Patterson, G. R. (2002a). The early development of coercive family process. In J. B. Reid, G. R. Patterson, & J. Snyder, *Antisocial behavior in children and adolescents: A developmental analysis and model for intervention* (pp. 25–44). American Psychological Association. <https://doi.org/10.1037/10468-002>
- Patterson, G. R. (2002b). *The early development of coercive family process* 25. <https://doi.org/10.1037/10468-002>
- Pettit, G. S., & Arsiwalla, D. D. (2008). Commentary on Special Section on “Bidirectional parent–child Relationships”: The Continuing evolution of dynamic, transactional models of parenting and youth behavior problems. *Journal of Abnormal Child Psychology*, 36(5), 711–718. <https://doi.org/10.1007/s10802-008-9242-8>.
- Pfefferle, S. G., & Spitznagel, E. L. (2009). Children’s mental health service use and maternal mental health: A path analytic model. *Children and Youth Services Review*, 31(3), 378–382.
- Plewis, I. (2007). *The Millennium Cohort Study: Technical report on sampling* (4th Edition). Centre for Longitudinal Studies. http://doc.ukdataservice.ac.uk/doc/4683/mrdoc/pdf/mcs_technical_report_on_sampling_4th_edition.pdf
- Poole, L. A., Knight, T., Toumbourou, J. W., Lubman, D. I., Bertino, M. D., & Lewis, A. J. (2018). A randomized controlled trial of the impact of a family-based adolescent Depression intervention on both youth and parent Mental Health Outcomes. *Journal of Abnormal Child Psychology*, 46(1), 169–181. <https://doi.org/10.1007/s10802-017-0292-7>.
- Ranøyen, I., Klöckner, C. A., Wallander, J., & Jozefiak, T. (2015). Associations between internalizing problems in adolescent daughters Versus Sons and Mental Health problems in mothers Versus fathers (the HUNT study). *Journal of Child and Family Studies*, 24(7), 2008–2020. <https://doi.org/10.1007/s10826-014-0001-x>.
- Reiss, F. (2013). Socioeconomic inequalities and mental health problems in children and adolescents: A systematic review. *Social Science & Medicine*, 90, 24–31. <https://doi.org/10.1016/j.socscimed.2013.04.026>.
- Reupert, A., & Maybery, D. (2016). What do we know about families where parents have a mental illness? A systematic review. *Child & Youth Services*, 37(2), 98–111. <https://doi.org/10.1080/0145935X.2016.1104037>.
- Riany, Y. E., Haslam, D. M., & Sanders, M. (2022). Parental Mood, parenting style and child emotional and behavioural Adjustment: Australia-Indonesia Cross-Cultural Study. *Journal of Child and Family Studies*, 31(9), 2331–2343. <https://doi.org/10.1007/s10826-021-02137-5>.
- Ringoot, A. P., Tiemeier, H., Jaddoe, V. W. V., So, P., Hofman, A., Verhulst, F. C., & Jansen, P. W. (2015). Parental depression and child well-being: Young children’s self-reports helped addressing biases in parent reports. *Journal of Clinical Epidemiology*, 68(8), 928–938. <https://doi.org/10.1016/j.jclinepi.2015.03.009>.
- Rutter, M., Caspi, A., & Moffitt, T. E. (2003). Using sex differences in psychopathology to study causal mechanisms: Unifying issues and research strategies. *Journal of Child Psychology and Psychiatry*, 44(8), 1092–1115. <https://doi.org/10.1111/1469-7610.00194>.
- Sameroff, A. (1975). Transactional models in early Social Relations. *Human Development*, 18(1/2), 65–79.
- Sameroff, A. J. (2000). Developmental systems and psychopathology. *Development and Psychopathology*, 12(3), 297–312. <https://doi.org/10.1017/S0954579400003035>.
- Sameroff, A. (2009). *The transactional model of development: How children and contexts shape each other* (pp. xiv, 290). American Psychological Association. <https://doi.org/10.1037/11877-000>
- Serbin, L. A., Kingdon, D., Ruttle, P. L., & Stack, D. M. (2015). The impact of children’s internalizing and externalizing problems on parenting: Transactional processes and reciprocal change over time. *Development and Psychopathology*, 27(4pt1), 969–986. <https://doi.org/10.1017/S0954579415000632>.
- Sifaki, M., Midouhas, E., Papachristou, E., & Flouri, E. (2021). Reciprocal relationships between paternal psychological distress and child internalising and externalising difficulties from 3 to 14 years: A cross-lagged analysis. *European Child & Adolescent Psychiatry*, 30(11), 1695–1708. <https://doi.org/10.1007/s00787-020-01642-0>.
- Sigmon, S. T., Pells, J. J., Boulard, N. E., Whitcomb-Smith, S., Edensfield, T. M., Hermann, B. A., LaMattina, S. M., Schartel, J. G., & Kubik, E. (2005). Gender differences in Self-Reports of Depression: The response Bias Hypothesis Revisited. *Sex Roles*, 53(5), 401–411. <https://doi.org/10.1007/s11199-005-6762-3>.
- Speyer, L. G., Hall, H. A., Hang, Y., Hughes, C., & Murray, A. L. (2022). Within-family relations of mental health problems across childhood and adolescence. *Journal of Child Psychology and Psychiatry*, (n/a). <https://doi.org/10.1111/jcpp.13572>
- Spruit, A., Goos, L., Weenink, N., Rodenburg, R., Niemeyer, H., Stams, G. J., & Colonesi, C. (2020). The relation between attachment and depression in children and adolescents: A Multilevel Meta-Analysis. *Clinical Child and Family Psychology Review*, 23(1), 54–69. <https://doi.org/10.1007/s10567-019-00299-9>.
- StataCorp. (2021). *Stata Statistical Software: Release 17*. StataCorp LLC.
- Stewart, S. M., & Bond, M. H. (2002). A critical look at parenting research from the mainstream: Problems uncovered while adapting western research to non-western cultures. *British Journal of Developmental Psychology*, 20(3), 379–392. <https://doi.org/10.1348/026151002320620389>.
- Sweeney, S., & MacBeth, A. (2016). The effects of paternal depression on child and adolescent outcomes: A systematic review. *Journal of Affective Disorders*, 205, 44–59. <https://doi.org/10.1016/j.jad.2016.05.073>.
- Tingay, K. S., Bandyopadhyay, A., Griffiths, L., Akbari, A., Brophy, S., Bedford, H., Cortina-Borja, M., Setakis, E., Walton, S., Fitzsimons, E., Dezateux, C., & Lyons, R. (2019). Record linkage to enhance consented cohort and routinely collected health data from a UK birth cohort. *International Journal of Population Data Science*, 4(1), <https://doi.org/10.23889/ijpds.v4i1.579>.
- Turney, K. (2012). Pathways of disadvantage: Explaining the relationship between maternal depression and children’s problem behaviors. *Social Science Research*, 41(6), 1546–1564. <https://doi.org/10.1016/j.ssresearch.2012.06.003>.
- Vallotton, C., Harewood, T., Froyen, L., Brophy-Herb, H., & Ayoub, C. (2016). Child behavior problems: Mothers’ and fathers’ mental health matters today and tomorrow. *Early Childhood Research Quarterly*, 37, 81–93. <https://doi.org/10.1016/j.ecresq.2016.02.006>.
- van der Waerden, J., Galéra, C., Larroque, B., Saurel-Cubizolles, M. J., Sutter-Dallay, A. L., & Melchior, M. (2015). Maternal Depression Trajectories and Children’s Behavior at Age 5 years. *The Journal of Pediatrics*, 166(6), 1440–1448e1. <https://doi.org/10.1016/j.jpeds.2015.03.002>.
- Van Loon, L. M. A., Van de Ven, M. O. M., Van Doesum, K. T. M., Witteman, C. L. M., & Hosman, C. M. H. (2014). The relation

- between parental Mental illness and adolescent Mental Health: The role of family factors. *Journal of Child and Family Studies*, 23(7), 1201–1214. <https://doi.org/10.1007/s10826-013-9781-7>.
- Van Roy, B., Grøholt, B., Heyerdahl, S., & Clench-Aas, J. (2006). Self-reported strengths and difficulties in a large norwegian population 10–19 years. *European Child & Adolescent Psychiatry*, 15(4), 189–198. <https://doi.org/10.1007/s00787-005-0521-4>.
- Vreeland, A., Gruhn, M. A., Watson, K. H., Bettis, A. H., Compas, B. E., Forehand, R., & Sullivan, A. D. (2019). Parenting in Context: Associations of parental depression and socioeconomic factors with parenting behaviors. *Journal of Child and Family Studies*, 28(4), 1124–1133. <https://doi.org/10.1007/s10826-019-01338-3>.
- Wang, Y., Shi, H., Wang, Y., Zhang, X., Wang, J., Sun, Y., Wang, J., Sun, J., & Cao, F. (2021). The association of different parenting styles among depressed parents and their offspring's depression and anxiety: A cross-sectional study. *Bmc Psychiatry*, 21(1), 495. <https://doi.org/10.1186/s12888-021-03512-8>.
- Welberg, L. M., & Seckl, J. R. (2001). Prenatal stress, Glucocorticoids and the programming of the brain. *Journal of Neuroendocrinology*, 13(2), 113–128. <https://doi.org/10.1111/j.1365-2826.2001.00601.x>.
- Williamson, D., & Johnston, C. (2015). Gender differences in adults with attention-deficit/hyperactivity disorder: A narrative review. *Clinical Psychology Review*, 40, 15–27. <https://doi.org/10.1016/j.cpr.2015.05.005>.
- Wüstner, A., Otto, C., Schlack, R., Hölling, H., Klasen, F., & Ravens-Sieberer, U. (2019). Risk and protective factors for the development of ADHD symptoms in children and adolescents: Results of the longitudinal BELLA study. *PLOS ONE*, 14(3), e0214412. <https://doi.org/10.1371/journal.pone.0214412>.
- Xerxa, Y., Rescorla, L. A., van der Ende, J., Hillegers, M. H. J., Verhulst, F. C., & Tiemeier, H. (2021). From parent to child to parent: Associations between parent and offspring psychopathology. *Child Development*, 92(1), 291–307. <https://doi.org/10.1111/cdev.13402>.
- Yamagata, S., Takahashi, Y., Ozaki, K., Fujisawa, K. K., Nonaka, K., & Ando, J. (2013). Bidirectional influences between maternal parenting and children's peer problems: A longitudinal monozygotic twin difference study. *Developmental Science*, 16(2), 249–259. <https://doi.org/10.1111/desc.12021>.
- Yamamoto, R., & Keogh, B. (2018). Children's experiences of living with a parent with mental illness: A systematic review of qualitative studies using thematic analysis. *Journal of Psychiatric and Mental Health Nursing*, 25(2), 131–141. <https://doi.org/10.1111/jpm.12415>.
- Yan, N., & Ansari, A. (2016). Child Adjustment and parent functioning: Considering the role of child Driven Effects. *Journal of Family Psychology: JFP : Journal of the Division of Family Psychology of the American Psychological Association (Division 43)*, 30(3), 297–308. <https://doi.org/10.1037/fam0000180>.
- Young, S., Adamo, N., Ásgeirsdóttir, B. B., Branney, P., Beckett, M., Colley, W., Cubbin, S., Deeley, Q., Farrag, E., Gudjonsson, G., Hill, P., Hollingdale, J., Kilic, O., Lloyd, T., Mason, P., Paliokosta, E., Perecherla, S., Sedgwick, J., Skirrow, C., & Woodhouse, E. (2020). Females with ADHD: An expert consensus statement taking a lifespan approach providing guidance for the identification and treatment of attention-deficit/ hyperactivity disorder in girls and women. *Bmc Psychiatry*, 20(1), 404. <https://doi.org/10.1186/s12888-020-02707-9>.
- Claim Child Benefit* (2021). GOV.UK. <https://www.gov.uk/child-benefit>
- EHCAP (2014). *Scoring the Strengths & Difficulties Questionnaire for age 4–17*. <https://www.ehcap.co.uk/content/sites/ehcap/uploads/NewsDocuments/236/SDQEnglishUK4-17scoring-1.PDF>

Publisher's Note Springer Nature remains neutral with regard to jurisdictional claims in published maps and institutional affiliations.

Springer Nature or its licensor (e.g. a society or other partner) holds exclusive rights to this article under a publishing agreement with the author(s) or other rightsholder(s); author self-archiving of the accepted manuscript version of this article is solely governed by the terms of such publishing agreement and applicable law.