

Model of the Photoacoustic Helmholtz Resonator with Conical-Ended Duct

Mariusz Suchenek

Received: 18 October 2013 / Accepted: 16 January 2014 / Published online: 7 February 2014
© The Author(s) 2014. This article is published with open access at Springerlink.com

Abstract The article presents models of a photoacoustic Helmholtz resonator in which the duct is ended with conical profiles. The analytical descriptions led to poor results, and a partly numerical model was presented, in which cone sections of the duct were stepped-approximated by dividing them into a number of short segments with different diameters. The accuracy of the model was compared to the best models of a photoacoustic Helmholtz cell with a constant diameter duct. The proposed stepped-approximation can be used as well for modeling photoacoustic Helmholtz resonators with other profiles of the duct.

Keywords Conical duct model · Helmholtz resonator · Influence of the duct shape · Stepped model

1 Introduction

Helmholtz resonators are used in many applications, e.g., for noise reduction [1,2], acoustic attenuation [3], etc. A very important advantage of the Helmholtz resonator is its relatively small size. Such a resonator with a size of just a few centimeters can have a relatively low resonance frequency of about 100 Hz to 200 Hz [4,5]. Obtaining similar effects with a resonator with longitudinal resonance would require a length in the range of tens of centimeters. Helmholtz resonators are commonly used in photoacoustics [6–8]. The photoacoustic signal is inversely proportional to the excitation frequency and volume of the resonator [9], and keeping both—the cell volume and resonance

M. Suchenek (✉)
Institute of Electronic Systems, Warsaw University of Technology,
Nowowiejska 15/19, 00-665 Warsaw, Poland
e-mail: msuchene@mion.elka.pw.edu.pl; M.Suchenek@ise.pw.edu.pl

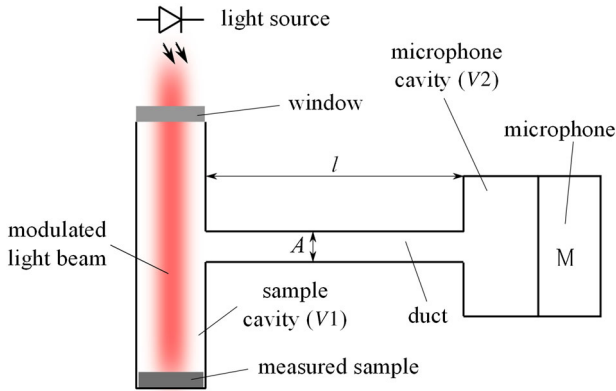

Fig. 1 Example of a Helmholtz resonator used in photoacoustic experiments

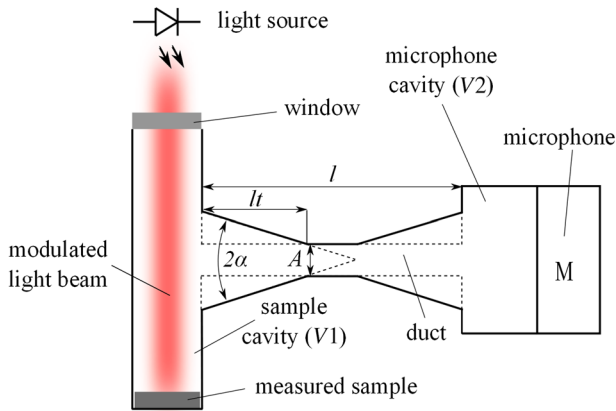

Fig. 2 Modified structure of the photoacoustic Helmholtz cell, with cone profiles at the ends of the duct

frequency low, may be quite difficult with longitudinal resonance cells, while with the Helmholtz structure, it is relatively easy.

2 Modified Helmholtz Resonator

A photoacoustic Helmholtz cell consists usually of two cavities connected with a duct. Typically in one of the cavities a measured sample is placed, while in the second, a microphone is located (Fig. 1). A major drawback of Helmholtz resonators used in photoacoustic applications is concerned with their relatively low quality factors. Practically, achievable Q-factor values range from a few to about 25 [10, 11]. Taking into consideration that noticeable losses (resulting in a lower Q-factor) can occur at the duct-cavity boundaries, one of the attempts to develop a Helmholtz resonator with a higher quality factor led to a cell design with cone profiles at the ends of the duct (Fig. 2) [12].

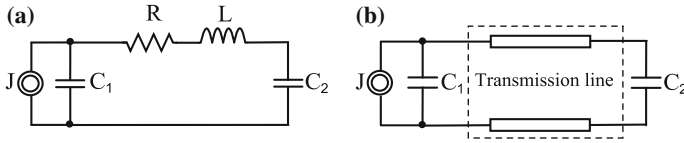

Fig. 3 Simple photoacoustic Helmholtz cell models with (a) lumped elements and (b) transmission line

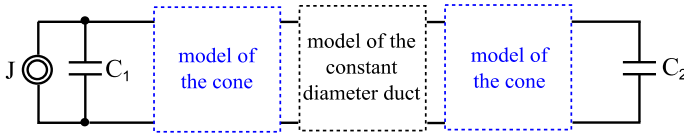

Fig. 4 Simple model of the photoacoustic Helmholtz cell with conical-ended duct

3 Model of the Helmholtz Resonator with Conical-Ended Duct

Previously existing models of photoacoustic Helmholtz resonators allowed for modeling cells with ducts of constant diameters only [11, 13–15]. Such models were usually based on acousto-electrical analogies with either lumped elements (Fig. 3a) or a transmission line (Fig. 3b).

In both cases, the behavior of the cavity volumes V_1 and V_2 is modeled by capacitances (C_1 and C_2 , respectively), while the behavior of the duct is described in two different ways. In the model with lumped elements, the duct is represented by a series connection of resistance R and inductance L , while in the transmission line model, the duct is considered as a transmission line. Furthermore, the mentioned components (capacitors, inductors, resistors, transmission line) may be defined in many different ways [11, 13–23]. In order to limit the number of model variants, some preliminary experimental verification of the models was performed [24], leading to the conclusion that the best results are obtained with the transmission line model and the model with lumped elements presented by Kastle and Sigrist [15]. Hence, in further analysis, only these two model variants were used. In order to include the influence of the conical duct ends in the model of the modified Helmholtz cell, the duct was considered as consisting of three sections: constant diameter duct section in the middle and two cone sections at both sides. Use of the other components (i.e., capacitances C_1 , C_2 , and the current source J), as in the previous models, resulted in a structure shown in Fig. 4.

In the presented structure, the section of the duct with a uniform diameter can be modeled as previously shown, as a connection of the resistance and inductance or as a transmission line. The new elements which have to be defined are the two conical sections. In the acoustical literature models of such conical ducts have been widely used. The descriptions which can be relatively easily converted into four-terminal networks were given by Fletcher and Thwaites [25] and by Mapes-Riordan [23]. Unfortunately, use of these definitions combined with the mentioned lumped or transmission line duct model of the middle section gives unsatisfactory results [24]. For example, measurements of two cells, one of which had a slightly modified duct (short cone section with low values of the alpha angle) and the other with a constant

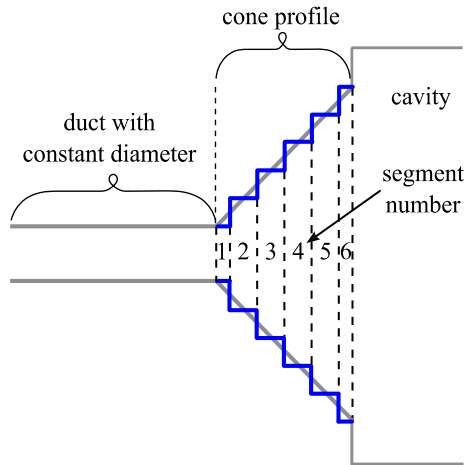

Fig. 5 Approximation of the cone section with number of short constant diameter segments

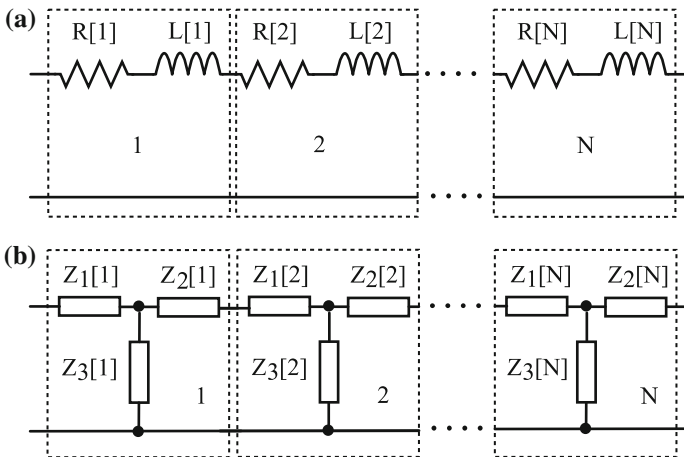

Fig. 6 Stepped model of a cone section with (a) lumped elements and (b) transmission lines converted into T-sections

duct diameter (no cone sections), gave nearly identical quality factors and resonance frequencies. Modeling of these cells predicted large differences of these values.

Due to poor results of the analytical model described above, a partly numeric approach was applied. In this approach, the cone sections of the duct were stepped-approximated by dividing the cone profiles into a number of short segments with different diameters (Fig. 5). Similar approximations are used quite often in numerical methods (e.g., for numerical calculations of integrals by the trapezoidal method). With a sufficiently large number of sections, the resulting shape is very close to the cone profile. In the same manner, nearly any other profile of the duct (e.g., exponential horn) can be approximated [26–28].

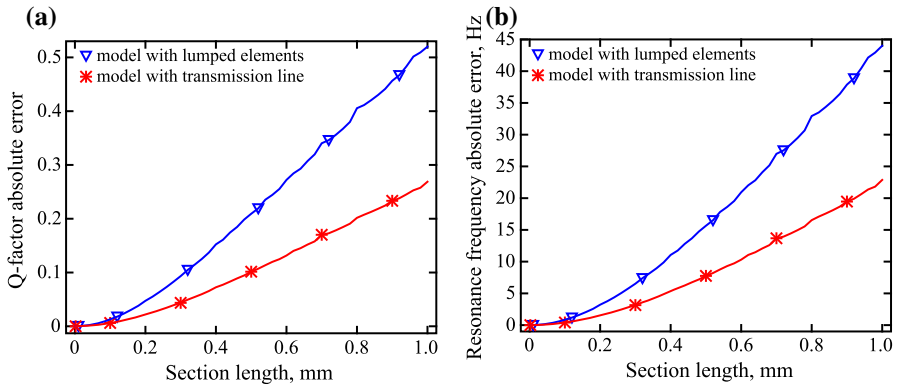

Fig. 7 Influence of the section length on (a) Q-factor and (b) resonance frequency, for the model with lumped elements and model with transmission line

As a result of the above approach, the cone sections of the duct can be modeled by a serial connection of sections containing lumped elements (Fig. 6a) or transmission lines (Fig. 6b), depending on the model used for the constant diameter duct segments.

For the purpose of further analysis, the length of a single segment was set to 0.11 mm for the model with lumped element segments and to 0.16 mm for the model with transmission line segments. The above values were obtained from preliminary numerical tests, in which the impact of various lengths of the segments on the resonance frequency and Q-factor was checked [10]. Model calculations were performed for the cells in which the sample and the microphone cavities had volumes of 2 cm³, the total duct length was 10 mm, and the duct diameter was 1 mm. The cone sections angle ranged from 1° to 75°, and the cone length from 0.2 mm to 4.8 mm. The results were compared with a reference model in which the segments were 2 μm long. Deviations from such a reference model are shown in Fig. 7. With the segments for which the length was set to 0.11 mm and 0.16 mm as already mentioned, the resonance frequency deviations from the reference model were less than 1 Hz.

4 Experimental Verification

In order to verify the accuracy of the models, a number of photoacoustic Helmholtz cells were assembled. To provide a high level of the photoacoustic signal, the bottom of the sample cavity was filled with a thin layer of the graphite powder. For the same reason, a 1 W LED diode was used as the light source. The frequency response of the cell was obtained by measuring the output amplitudes point-by-point at different modulation frequencies [29]. From each measurement, two parameters were extracted, i.e., the resonance frequency and quality factor. Variation in parameters between measurements was less than 8%. Those values were compared with the data obtained from the developed models. The investigations covered the behavior of the models when changing the length of the cone sections with the cone angle fixed at 33° (Fig. 9) and when changing the cone angle with the length of the cone sections fixed at 3 mm (Fig. 8). In

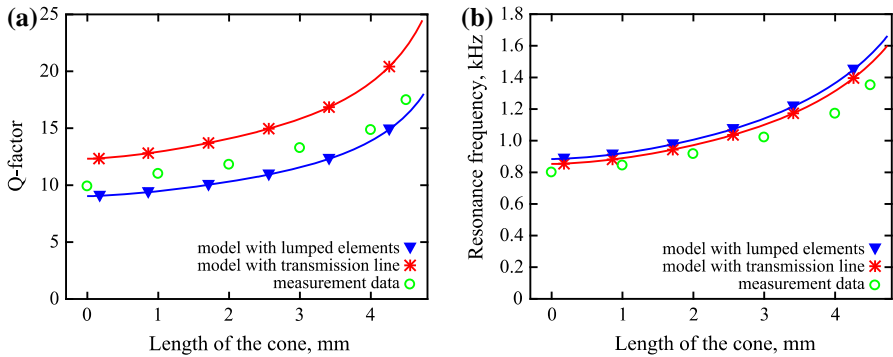

Fig. 8 Influence of the cone section length on the Q-factor and resonance frequency of the photoacoustic Helmholtz cell (cone angle fixed at 33° , sample cavity volume of 3 cm^3 , microphone cavity volume of 2 cm^3 , total duct length of 10 mm, and duct diameter of 1 mm)

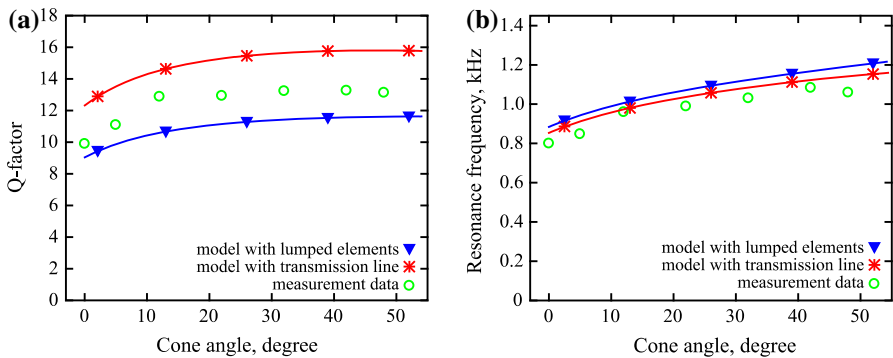

Fig. 9 Influence of the angle of the cone section on the Q-factor and resonance frequency of the photoacoustic Helmholtz cell (both cone sections 3 mm long, sample cavity volume of 3 cm^3 , microphone cavity volume of 2 cm^3 , total duct length of 10 mm, and duct diameter of 1 mm)

all cases, the total length of the duct was 10 mm, the microphone cavity volume was 2 cm^3 , the sample cavity volume was 3 cm^3 , and the duct diameter was 1 mm.

In the case of photoacoustic Helmholtz cells, research usually reports significant errors of modeling [24,30]. Hence, it can be easily noticed from Figs. 8 and 9 that errors in determination of the quality factor of both models are at the level of tens of percent and still the models can be considered as quite accurate. Errors of modeling of standard photoacoustic Helmholtz cells (with a duct of constant diameter) are at a similar level, and must have been transferred to the newly developed model. Minor irregularities of the measured data, e.g., values for the angle of 12° in Fig. 9 result from a non-ideal cone profile of the measured cell. A similar problem was observed at the angle of 52° . Appropriate assembling of the cone profile is very important, slight deviations from the designed dimensions result in significant changes in the resonance frequency and Q-factor values. It is also clearly visible that the presented models correctly follow the trends of experimental data.

As a result, although both models may require some improvements in order to increase their accuracy, they should be considered as useful for the preliminary estimation of the behavior of the photoacoustic Helmholtz cells with duct profiles with conical ends. The same approach can be probably successfully used also for other duct profiles with a variable diameter.

5 Conclusions

The presented partially numerical model, in which cone sections were approximated with a number of short constant diameter duct segments, allows one to obtain satisfactory results. The level of the errors introduced by such a model is comparable to the error levels of the best models of a photoacoustic Helmholtz cell with a constant diameter of the duct. The use of lumped components and transmission lines for modeling the cone segments resulted in a similar overall accuracy. Although this paper discussed a model which was used for a photoacoustic Helmholtz resonator with a conical-ended duct, a similar approach can be used for modeling Helmholtz resonators with other duct profiles.

Open Access This article is distributed under the terms of the Creative Commons Attribution License which permits any use, distribution, and reproduction in any medium, provided the original author(s) and the source are credited.

References

1. S. Unnikrishnan Naira, C.D. Shetea, A. Subramoniam, K.L. Handooa, C. Padmanabhanb, Appl. Acoust. **71**, 61 (2010)
2. S. Sang-Hyun, K. Yang-Hann, J. Acoust. Soc. Am. **118**, 2332 (2005)
3. S. Griffin, S.A. Lane, S. Huybrechts, J. Vib. Acoust. **123**, 11 (2001)
4. S.V. Gorin, M.V. Kuklin, Russian Eng. Res. **32**, 115 (2012)
5. S.K. Tang, C.H. Ng, E.Y.L. Lam, Appl. Acoust. **73**, 969 (2012)
6. V. Zeninari, V.A. Kapitanov, D. Courtois, Yu.N. Ponomarev, Infrared Phys. Technol. **40**, 1 (1999)
7. Z. Wang, Y. Hu, Z. Meng, M. Ni, Opt. Lett. **33**, 37 (2008)
8. A. Grossela, V. Zéninaria, L. Jolya, B. Parvittea, G. Durrya, D. Courtoisa, Infrared Phys. Technol. **51**, 95 (2007)
9. A. Rosencwaig, A. Gersho, J. Appl. Phys. **47**, 64 (1976)
10. M. Suchenek, *Analiza wpływu stożkowych połączeń kanal-wneka na parametry fotoakustycznych komór Helmholtza (Analysis of the Influence of Conical Connections Between Duct and Cavity on Parameters of the Photoacoustic Helmholtz Cells)*, Chap. 9.C, Ph.D. Dissertation, Warsaw University of Technology, Warsaw, 2011, pp. 89–102
11. M. Mattiello, M. Nikles, S. Schilt, L. Thevenaz, A. Salhi, D. Bart, Y. Rouillard, R. Werner, J. Koeth, Spectrochim. Acta A **63**, 952 (2006)
12. M. Suchenek, Int. J. Thermophys. **32**, 886 (2011)
13. O. Nordhaus, J. Pelzl, Appl. Phys. **25**, 221 (1981)
14. J. Pelzl, K. Klein, O. Nordhaus, App. Opt. **21**, 94 (1982)
15. R. Kastle, M.W. Sigrist, Appl. Phys. B **63**, 389 (1996)
16. J. Blit, *Elements of Acoustic*, Chap. 5 (Butterworths, London, 1964), pp. 68–70
17. A.H. Benade, J. Acoust. Soc. Am. **44**, 616 (1968)
18. F.B. Daniels, J. Acoust. Soc. Am. **22**, 563 (1950)
19. F.B. Daniels, J. Acoust. Soc. Am. **19**, 569 (1947)
20. A.W. Nolle, J. Acoust. Soc. Am. **25**, 32 (1953)
21. P.M. Morse, *Vibration and Sound*, Chap. VI.23 (McGraw-Hill, New York, 1948), pp. 233–265

22. G.R. Plitnik, W.J. Strong, *J. Acoust. Soc. Am.* **65**, 816 (1979)
23. D. Mapes-Riordan, *J. Audio Eng. Soc.* **41**, 471 (1993)
24. M. Suchenek, *Proc. SPIE* **6937**, 1 (2008)
25. N.H. Fletcher, S. Thwaites, *Acustica* **65**, 194 (1988)
26. F.J. Young, *J. Acoust. Soc. Am.* **39**, 841 (1966)
27. F.J. Young, B.H. Young, *J. Acoust. Soc. Am.* **33**, 1206 (1961)
28. F.J. Young, B.H. Young, *J. Acoust. Soc. Am.* **33**, 813 (1961)
29. M. Suchenek, *Int. J. Thermophys.* **32**, 893 (2011)
30. T. Starecki, *J. Acoust. Soc. Am.* **122**, 2118 (2007)