

Correction to: Ultra-low-power bulk-driven fully differential subthreshold OTAs with partial positive feedback for G_m -C filters

Tripurari Sharan¹  · Priyanka Chetri¹ · Vijaya Bhadauria²

Published online: 9 February 2018
© Springer Science+Business Media, LLC, part of Springer Nature 2018

Correction to: Analog Integr Circ Sig Process

<https://doi.org/10.1007/s10470-017-1065-5>

The original version of this article unfortunately contained a mistake. The presentation of Fig. 3 was incorrect. The correct version of Fig. 3 is given below.

Fig. 3 The subthreshold FD-OTA, having bulk-driven FVF input core with partial positive feedback and current mirror self-cascode load

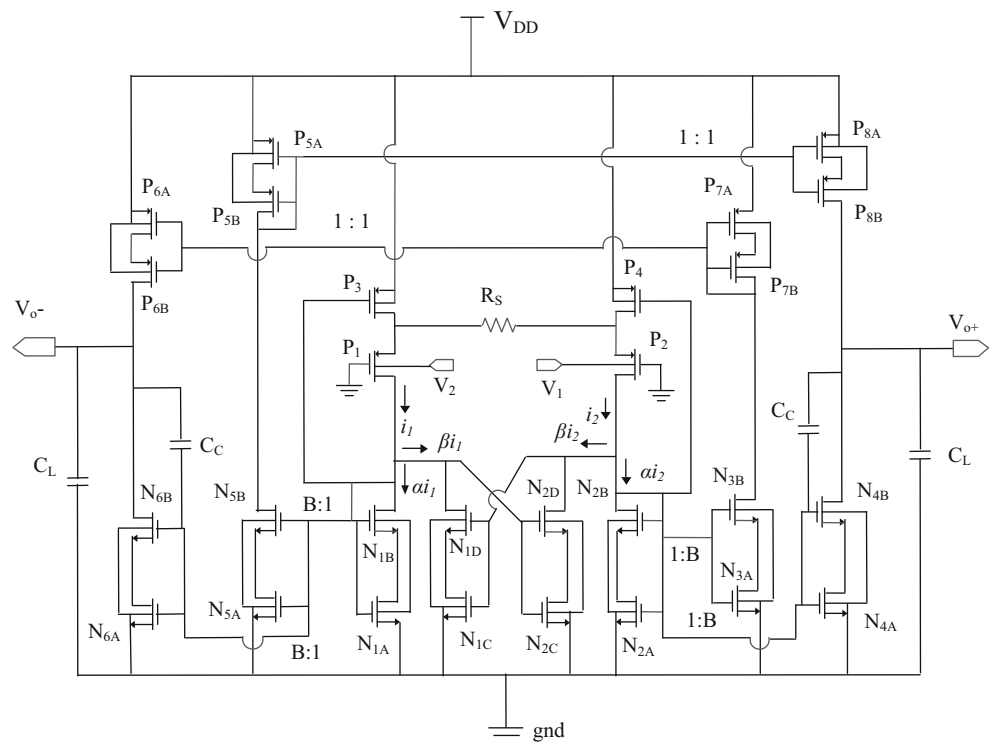

The original article can be found online at <https://doi.org/10.1007/s10470-017-1065-5>.

✉ Tripurari Sharan
tsh1962mzp@gmail.com

Priyanka Chetri
priyankachetri17@gmail.com

Vijaya Bhadauria
vijaya@mnnit.ac.in

¹ ECE Department of North Eastern Regional Institute of Science and Technology, Nirjuli, Arunachal Pradesh 791109, India

² ECE Department of Motilal Nehru National Institute of Technology, Teliyar Ganj, Uttar Pradesh 211004, India