



# Image Exchange in the Middle East: a Survey

Monief Eid<sup>1</sup> · Mosa Al Mutairi<sup>2</sup> · Hakki M. Karakas<sup>3,4,5</sup> · Usama Mohammad Hassan Al Bastaki<sup>6</sup> · Abdulaziz Abdulrahman Nasser Almosabihi<sup>7</sup> · Adel Abdulkader Tash<sup>8</sup> · Nasser Mohammed Al Huqbani<sup>9</sup> · Abdulelah Abdulrahman AlMayman<sup>10</sup> · Alabbas Nasser Albarakati<sup>10</sup> · Reem AlRakaf<sup>11</sup> · Mohammed Othman Alomair<sup>12</sup> · Bader Awladthani<sup>13</sup>

Received: 25 November 2021 / Revised: 15 July 2022 / Accepted: 19 July 2022 / Published online: 7 September 2022  
© The Author(s) under exclusive licence to Society for Imaging Informatics in Medicine 2022

## Abstract

Developing an enterprise approach to imaging technology rather than a radiology focus has recently increased. The communicator needs to be aware of this shift.

The Middle East countries participated in the survey have confirmed the following major benefits of Medical Image Exchange:

- ✓ Fast access to both image and report
- ✓ Enable tele-services for second opinion, consulting and reporting
- ✓ Improve patient journey, workflow and diagnosis
- ✓ Allowed more patient engagement to be in place

The Middle East countries that participated in this survey have agreed on the following shared challenges regarding Medical Imaging Exchange:

- ✓ Lack of enterprise imaging governance at the early stage of implementation. It will organize the who, when, and how. In addition, any fees and or payment involved for physicians
- ✓ Infrastructure availability to handle such large volume of data. Growing from mega-byte to petabyte per year is challenge for infrastructure. Cloud against On Premises-Installation implementation model
- ✓ Interoperability and integration to connect multi specialties from different systems. In addition, how far existing systems are ready for that. A standard-based framework is mature for image exchange, but what follows for other domains? There is a need to move beyond radiology images so as to include images from pathology, ophthalmology, and dermatology

There are other countries in the region requiring guidance, support, and funding to move forward from the compact disc into internet-based interoperable image exchange. This should be considered part of the World Health Organization and the United Nation development to the region in the healthcare sector.

## Introduction

### Background and History

Healthcare is undergoing its current transition from a volume- to a value-based payment models. These embrace Medical Imaging Exchange technology, work, and reimbursement. Developing an enterprise approach to imaging technology

rather than a radiology focus increased lately and made other specialists in imaging informatics to reinforce their value to healthcare services.

The adoption of informatics in healthcare is an opportunity not only to improve the current effectiveness, efficiency, and quality of health services but also to provide predictive analytics. Importantly, healthcare information technology (HIT) can enable the availability of information in real time at the point of care.

A current challenge in healthcare data exchange is specific to medical imaging. Examples include DICOM images from traditional imaging modalities such as CT, MRI, US,

✉ Monief Eid  
mmonief@moh.gov.sa

Extended author information available on the last page of the article

and ECHO, as well as non-DICOM images such as dermatologic photos and pathology slides in which the data is displayed as an image and not as text, graph, or diagram. All these images as well as their associated report and chart notes need to be regarded as part of the patients' health record, integrated into the EHR. There is a need for the medical image to be viewed remotely in order to enable consultation and second opinions. CD for many years has been the primary tool used to provide that service.

A requirement to enable value-based services is the enablement of immediate access to imaging exams across multiple geographic locations with coverage of multiple image specialties via internet-based exchange. Allowing the physician to access all prior necessary images with their reports and or progress notes enhances the quality of care that can be provided to the patient.

The Middle East region is a growing and demanding market in the domain of diagnostic imaging. Internet-based exchange is new. However, current installations shows that

it is promising and growing to include many types of health data including imaging.

### HIMSS and Imaging Maturity

The DIAM (Digital Imaging Adoption Model) by HIMSS is a key factor to enhance image exchange (1–3). The model exists to support implementing departments in the planning and implementation of imaging IT strategy and to address the challenges related to digitization and improving patient outcomes.

There are seven stages (Fig. 1) of DIAM that create the framework as follows:

- The early stages (0–4) are concerned with the planning and implementation of imaging IT. This included implementing key software applications relevant for managing the workflows as well as the images and reports acquired and produced in the imaging department, such as a RIS,

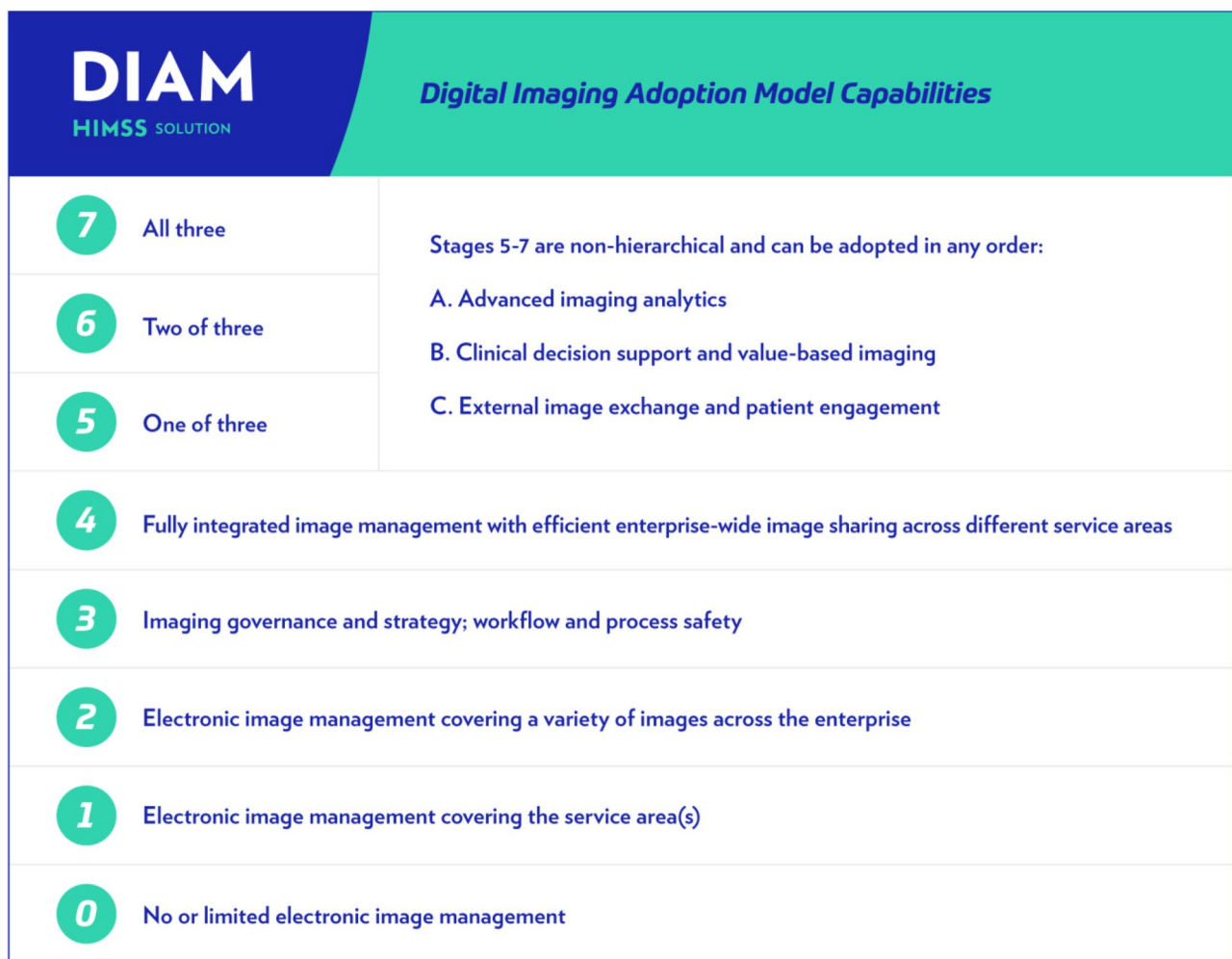

Fig. 1 HIMSS DIAM staging levels (from 0 to 7) (source HIMSS)

a PACS, or a vendor neutral archive (VNA). In addition, IMS (image management system) and RIS (radiology information system) should be fully integrated with the HIS/EMR. Furthermore, electronically supported processes for matching patient and examination identifiers ought to be in place.

- Stages 5–7 are non-hierarchical and allow for different approaches when making the best use of the most advanced software-related features such as advanced external image exchange and patient engagement.

### Middle East Survey Participation

The organizations choose up to 5 different imaging services to be assessed on the following 10 focus areas:

1. Image capture
2. Image exchange, data ingestion and interoperability
3. Image interpretation and notes
4. Clinical decision support
5. Image viewing
6. Quality management, workflow management and patient safety
7. Multidisciplinary collaboration
8. Imaging analytics

9. Patient engagement
10. Personalized medicine

Adoption of DIAM will help organizations to access medical images, reports, and notes throughout the whole enterprise and especially through pandemic time such as COVID-19 through the following directions (Fig. 2):

Last but not least, one of main barriers to interoperability is that institutions do not permit the installation of these image exchange systems on their computers because of security concerns. The image exchange's security and privacy is considered a main concern that requires high attention. The Audit Trail/Node Authentication repository offers standardized logging of all relevant activity throughout the network. It provides detailed information on who accessed, what records, and at what time. Usually, it is presented using a GUI with several filtering and search options.

In XDS environment, security is based on role-based access control which will restrict user permissions in the XDS transactions it is allowed to execute based on the role of the user. Organizations have to develop a privacy and security conceptual architecture that allow authorized users at different levels to access the image exchange throughout a set of common services based on international standard with consideration being given to IHE integration profiles such as ATNA and XUA as the standard approach deployment.

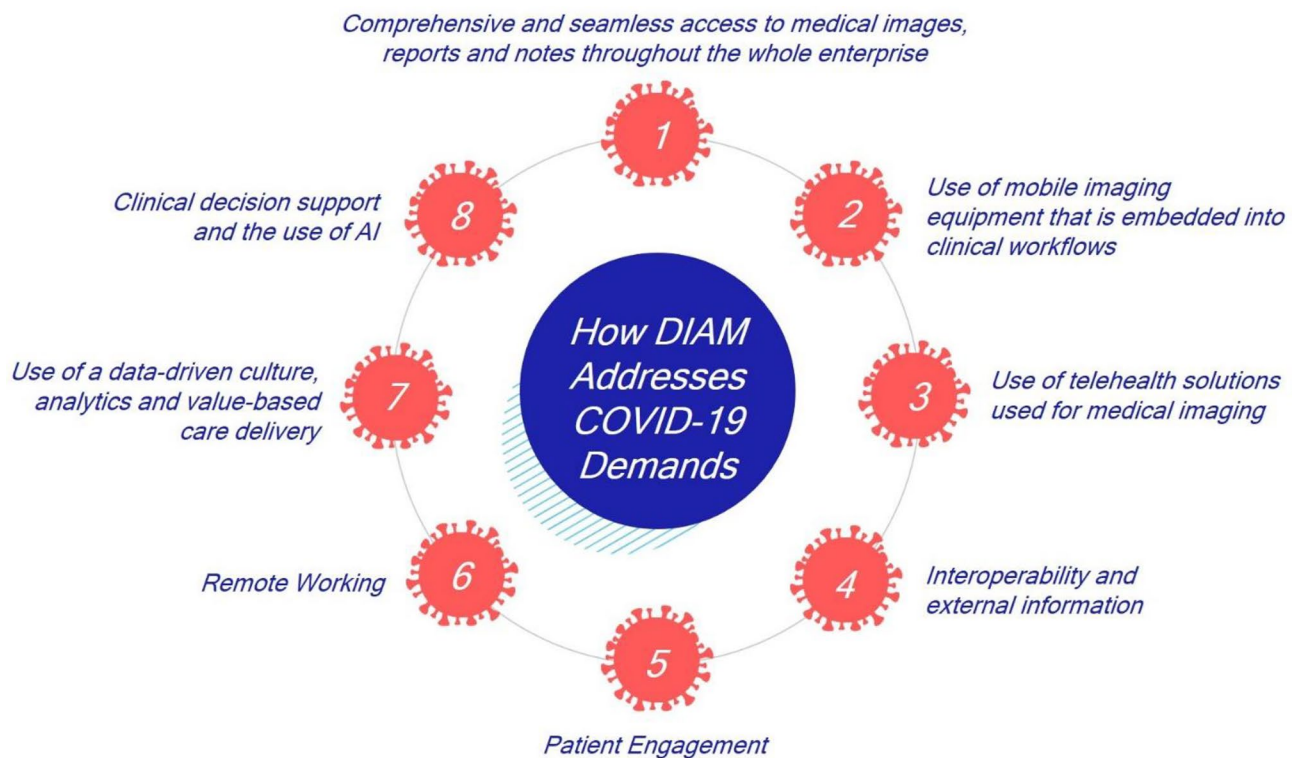

**Fig. 2** HIMSS DIAM addresses COVID-19 demands (source HIMSS)

## Methodology

### Data Collection

In this article, we are reviewing the current Middle East experience with examples of large-scale projects as well as the different imaging specialties involved. This survey has been conducted in portions of the Middle East region and demonstrates the variation by geographic area, imaging specialties group, infrastructure status, and the presence of governance to manage the process and policy throughout the exchange platform.

It is of paramount importance to evaluate the impact of participation in Medical Imaging Exchange service to provide value-based healthcare. The countries involved in the data collection are as follows: UAE, Saudi Arabia, Oman, and Turkey.

The data was collected in the above countries by obtaining answers to the following questions as well as personal interviews.

**Q1.** Is there Medical Image Exchange platform or solution that covers a chain of hospitals or regional or national level?

**Q2.** If so, how many studies and or images will be exchanged per year? And what size of? And are all modalities covered? And which modality is covered?

**Q3.** What type of standard is used for exchange? (DICOM, IHE-Profiles, or other).

**Q4.** Is the exchange for image or for both image and report?

**Q5.** What type of image specialties are exchanged (Radiology, Cardiology, Dental, ophthalmology, Dermatology, pathology, etc.)?

**Q6.** What are the five top challenges that you are facing while such image exchange is in place?

**Q7.** Is there any Governance committee and policy in place to run such image exchange?

**Q8.** Is there any plan to have Medical Image Exchange in case such an exchange platform does not exist?

**Q9.** Is there any integration between EMR/HIS and PACS and/or Medical Image Exchange solution?

**Q10.** If Medical Image Exchange in place, what type of viewer is used? Is it EMR/HIS viewer or Medical Image Exchange viewer?

**Q11.** How does organization management perceive the importance of Medical Image Exchange? Is it more or less importance than exchanging EMR/HIS data?

**Q12.** What do you exchange currently across your organization chain?

The survey has aggregated data for Medical Image Exchange to cover different and important parameters regarded as critical to exchange workflow such as:

- Data exchange governance
- Specialties involved in the exchange
- Barriers and challenges
- Integration and interoperability

The data were collected and aggregated from the following Middle East Countries through interviews, email, phone calls, and websites.

#### 1. Turkey

Ministry of Health - Turkey (Istanbul Health Authority)  
([www.saglik.gov.tr](http://www.saglik.gov.tr))  
([www.istanbulism.saglik.gov.tr](http://www.istanbulism.saglik.gov.tr))

#### 2. United Arab Emirates

Ministry of Health (Government Services) – UAE Dubai:  
Medical Image Exchange-Platform One & Medical Image Exchange-Platform Two  
(<https://www.mohap.gov.ae/en/Pages/default.aspx>)  
(GE Healthcare - UAE MOH.pdf)  
Ministry of Health (Government Services) -Abu Dhabi  
(<https://malaffi.ae/what-is-malaffi/about-malaffi/>)

#### 3. Saudi Arabia

Al Habib Medical Group (HMG, Private Group) - Saudi Arabia  
(<https://hmg.com/en/Pages/home.aspx>)  
Security Forces Hospital (Government Service) - Saudi Arabia:  
([www.sfh.med.sa](http://www.sfh.med.sa))  
National Guard Health Services (Government Service)- Saudi Arabia  
(<https://www.ngha.med.sa/English/Pages/default.aspx>)  
Ministry of Health (Government Service) - Saudi Arabia  
([www.moh.gov.sa](http://www.moh.gov.sa))

#### 4. Oman

Ministry of Health (Government Service) - Oman:  
(<https://www.moh.gov.om/en/home>)

All detailed answers are enclosed in the “References” part.

## Results

The Appendix provides the detailed answers provided to the Medical Images Exchange in the Middle East questionnaire. Here, we provide a brief summary of the results as follows:

- ✓ It demonstrates that Saudi Arabia is advanced at image exchange from a technology prospective compared to the rest of region while Turkey has the largest size and volume of image exchange compared to the rest of region. Saudi Arabia does have an image exchange at both government and private sectors as well as Turkey.

This platform could be pure DICOM or VNA. Standard for exchange both image and report is implemented and fully integrated with EMR/EHR is in place which will give the physicians flexible capacity of viewing through-out zero footprint (ZFP) viewer with diagnostic capacity.

For example King Abdulaziz Medical Centre (KAMC) at National Guard Health Services is one of the early organization to have been awarded DIAM stage 6 (Radiology Track) in the Middle East Region.

In practical terms, the DIAM assessment gave additional impetus to projects such as the implementation of a VNA, an enterprise-wide master patient index (MPI), cross reporting and analytics, which, in turn, had a positive impact on patient care. As an example, over 50,000 duplicate records were discovered among the Ministry of National Guard Health Affairs facilities. Care providers are now seeing single, unified patient imaging history records, which enable them to increase efficiency.

Before the KAMC completed its DIAM assessment, many requests for new features and services were made without valid justification. However, after the DIAM assessment, it was noticed that requests for enhancement are now significantly more likely to be justified and, thus, enable IT value. With this in mind, investment in open application provider interfaces (APIs) and implementation of HL7 standards and patient-centric IT enhancement requests were ranked as a first priority.

The variation among counties appeared to be due mainly to differences in infrastructure, budget capacity, and e-health strategy. The strong 2030 transformation process that Saudi

Arabia is going through helped in achieving many of these results.

In addition, it shows the maturity of image exchange is not limited to radiology specialty, but it is including other domains such as cardiology, endoscopy, and oncology.

It shows the traditional well-known challenges and barriers across the globe and the region that faced any image exchange.

The private sector in Saudi Arabia is participating and implementing strongly in imaging exchange and in some cases is quite advanced. A good example is that of the Al Habib Medical group (Fig. 3) across its hospitals chain with inclusion of EMR data.

In addition, here is another example from Saudi Arabia of MOH Cardiology Image Exchange Platform Use Cases (Fig. 4):

1. Use case 1: centralized data management and governance:
  - ✓ Study created and reported locally and all studies and reports sent to the Central VNA communicated back to other hospitals
  - ✓ All images produced at local sites are copied to the central VNA and stored according certain rules
  - ✓ Reports are copied to the central XDS repository and stored in standard CDA format, which will be recorded referenced in the Central IHE-Index to the patient identifier of the patient domain based on the Patient ID Assigning Authority send in the HL7 ORU message PID segment
2. Use case 2: cross hospital reporting utilizing Central VNA:

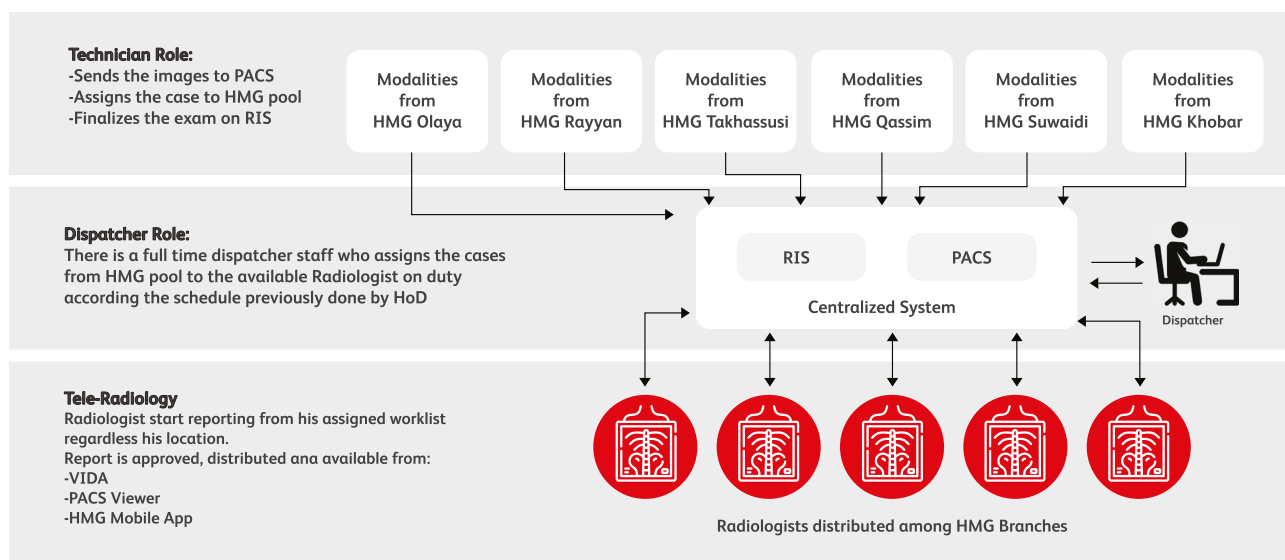
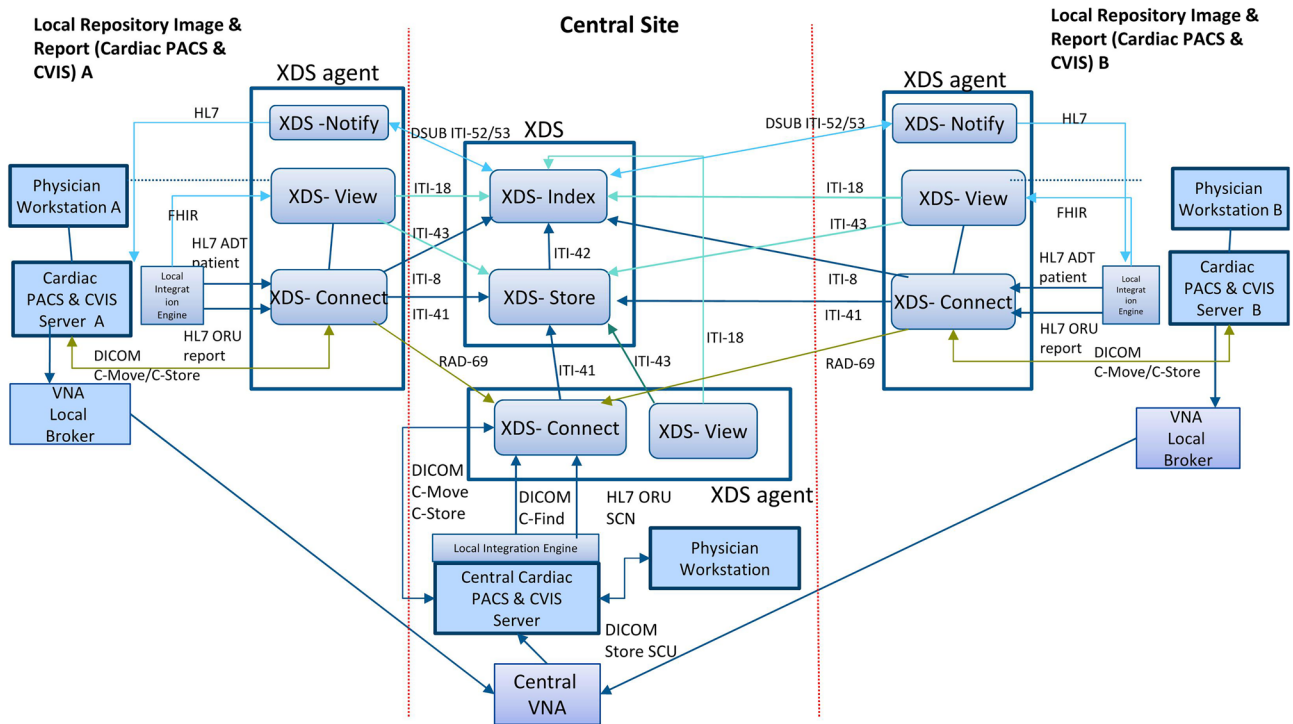

Fig. 3 Al Habib Medical Group Hospital Medical Image Architecture Design cross 5 hospitals in the Kingdom of Saudi Arabia (source: Al Habib Medical Group)



**Fig. 4** High interoperable cardiology image exchange level cross 8 cardiac centers at MOH in the Kingdom of Saudi Arabia showing the international standard utilized such as DICOM, JHL7, IHE Profiles, etc. (source: MOH cardiology)

- ✓ Study created at Hospital A, reported by physician at Hospital B using the Central VNA
  - ✓ Image is sent to Central VNA through DICOM send
  - ✓ Report at Riyadh Central VNA is created and finalized
  - ✓ Study and report are published to XDS and replaces original study
3. Use case 3: cross hospital reporting between two hospitals using XDS
- ✓ Study created at Hospital A, reported by physician at Hospital B using XDS functionality
  - ✓ Study transferred to Central VNA by Hospital A
  - ✓ Physician from hospital B select study to be reported and fetch from Central VNA takes place via XDS
  - ✓ Study is reported and finalized at Hospital B and replaces the original study from hospital A
4. Use case 4: reporting from physician’s Home:
- ✓ Study created at Hospital A, reported by physician from Hospital A from home
  - ✓ Study images acquired at Hospital A
  - ✓ Physician at home searches for patient and select study worklist for reporting
  - ✓ After finalizing the report, Images are auto-forwarded to Central VNA
  - ✓ Study and report are published to XDS and replaces original study
5. Use case 5: external DICOM study import in Hospital A:
- ✓ Study created from external source, imported by physician at Hospital A
  - ✓ Various profiles for study import
- Reporting of a study provided on CD/DVD
  - Second opinion on a study provided on CD/DVD
  - Study provided on (CD/DVD) for a referred patient
  - Old Study provided by (CD/DVD) which was requested for comparison
- ✓ UAE showed another different example in Medical Image Exchange. They have today partially implemented that cross group of hospitals at Ministry of Health based on PPP model. In addition, they have exchange platform at Dubai and Abu Dhabi for EMR including the radiology report; however, it is planned to expand this to include the images. The PPP medical image exchange platform one at Dubai has delivered a positive transformation in radiology. It aims to deliver the highest possible imaging services to patients at the highest diagnostic quality, to enable the best patient outcomes across UAE from independent geographical locations
- The main challenges faced the project as follows:
- Out-dated, localized film-based (analogue) imaging in hospitals

- Wide geographic region means physical transportation of images is expensive, insecure, and slow
- Radiologist skill shortages across the region
- Long patient waiting times for scans and reports
- Expected increase in patients putting pressure on waiting lists
- Finding or filing of hardcopy patient image records is slow with an image quality impact
- Archives take up hospital space and require specialist temperature control monitoring

However, Malaffi (4) (Arabic for “my file”) is operated by Abu Dhabi Health Data Services — Sole Proprietorship LLC (ADHDS), established as Public Private Partnership (PPP) between the Department of Health — Abu Dhabi (DOH) and Injazat, a regional leader in digital transformation, cloud, and cyber security. As part of the DOH’s strategic priorities, Malaffi is a key component of the digital transformation of the healthcare system in Abu Dhabi.

With universal, Emirate-wide participation of facilities and patients, every medical interaction a patient has, from a routine checkup, consultation or emergency treatment, to laboratory tests or radiology reports, is now collated in their personal file, with their medical history safely and securely stored and instantly accessible when needed.

This includes radiology report and will be expansion on the future to include image exchange.

By providing instant access to the patient’s longitudinal medical file, Malaffi facilitates the making of better-informed and more efficient clinical decisions, enhances coordination and transition of care, reduces unnecessary duplication of tests and procedures, reduces the risk of medical error, and improves patient safety and experience.

- ✓ Turkey also showed a very strong example of exchange throughout their Telemedicine platform while both private and public hospitals are interconnected. They have the largest Repository in the entire Middle East region with approximately 32.4 million exams and 3.24 billion images being exchanged per year. This approximates 1.6 petabyte per year. Modalities that are being covered are MRI (CT, X-ray, mammography, ultrasound, etc.), cardiology (ultrasound, ECG, angiography, etc.), and dental (panaromic, periapical, CT, etc.). There is no restriction regarding the specialty; all digital images, videos, and documents can be exchanged. In addition, the Turkish exchange platform is using the entire international standards as follows:

Uses HL7, DICOM, and XDS standards and implements following Integrating Healthcare Enterprise (IHE) profiles: Cross-enterprise Document Sharing for Imaging (XDS-I.b), Cross-Enterprise Clinical Documents Share (XDS.b), Cross-Community Access for Imaging, Consistent Presentation of

Images, Access to Radiology Information, Consistent Time, Audit Trail and Node Authentication, Mammography Image, Radiation Exposure Monitoring, Scheduled Workflow, Teaching file and Clinical Trial Export.

## Conclusions

All Middle East countries participated have confirmed the following major benefits of Medical Image Exchange:

- ✓ Fast access to both image and report
- ✓ Enable tele-services for second opinion, consulting and reporting
- ✓ Improve patient journey, workflow and diagnosis
- ✓ Allowed more patient engagement to be in place

In addition, all Middle East countries that participated in this survey have agreed on the following shared challenges regarding Medical Imaging Exchange:

- ✓ Lack of enterprise imaging governance at early stage of Implementation. It will organize who is who, when, and how. In addition, any fees and or payment involved for physicians
- ✓ Infrastructure availability to handle such large volume of data. Growing from mega-byte to petabyte per year is challenge for infrastructure. Cloud vs. on premises-installation implementation model
- ✓ Interoperability and integration to connect multi specialties from different systems. In addition, how far existing systems are ready for that. IHE framework is mature for image exchange, but what follows for other domains? There is a need to move beyond radiology images so as to include images from pathology, ophthalmology, and dermatology
- ✓ Financial constraints having enough budget to manage such large projects

Moreover, some of countries and/or organizations looked into a wider range of data exchange to cover different imaging specialties beyond radiology such as cardiology, endoscopy, dental, oncology, and surgery as part of their overall electronic medical record (EMR) strategy. The electronic medical chart (EHR) was the driver. Leadership involvement and sponsorship (for long-term success story) were key in such success.

Medical Image Exchange should be considered on one of the critical steps to improve Middle East HIT maturity and can be facilitated by the use of HIMSS-DIAM. This model will enhance the workflow and patient engagement. There are other countries in the region requiring guidance, support, and funding to move forward from the CD into internet-based interoperable image exchange. This should be considered part of WHO and UN development to the region in the healthcare sector.

## Appendix

| # | Questions (Q)  | Answer by:<br>Turkish Healthcare Service (Government Service)—Turkey<br>((Universal and private healthcare services))  | Answer by:<br>Ministry of Health (Government Services) – UAE (Dubai)- Platform One<br>((Universal and private healthcare services)) | Answer by:<br>Ministry of Health (Government Services) – UAE (Dubai)- Platform Two<br>((Universal and private healthcare services))   | Answer by:<br>Ministry of Health (Government Service)—Oman<br>((Universal and private healthcare services))  |
|---|--|--|---|---|--|
| 1 | Is there Medical Image Exchange platform or solution that covers a chain of hospitals or regional or national level?                               | There are medical exchange platforms that cover chain of hospitals both in national and regional level. The national platform is the National Telemedicine System (NTS). Some of the MoH Turkey's regional health jurisdictions —also — have their regional telemedicine systems such as Anatolia North Regional Telemedicine System   | Single platform (centralized solution) connecting 16 UAE MOH hospitals and 60 PHC's provided by GE                                  | This response relates to the solution installed at Dubai Health Authority (DHA), the Public Healthcare provider for the Emirate of Dubai, that consists of 4 hospitals and multiple primary healthcare centers and medical fitness centers (visa screening) | We have a national data exchange platform called NEHR AlShifa built using FHIR HL7 which is being currently utilized to share all medical data nationally. It currently covers government medical institutions deploying AlShifa only but a project is underway to cover the other institutes also including private sector. As part of this exchange, we are also sharing ECG's (in SVG format) and proposed to also share DICOM images using FHIR HL7  |
| 2 | If so, how many studies and or images will be exchanged per year? And what size of? And are all modalities covered? And which modality is covered? | Under the National Telemedicine System, 2014 private and public hospitals are interconnected. There are 342 million exams in the repository. Approximately 32.4 million exams and 3.24 billion images are being exchanged per year. This approximates 1.6 petabyte per year. Modalities that are being covered are MRI, CT, X-Ray, mammography, ultrasound etc.), cardiology (ultrasound, ECG, angiography, etc.), and dental (panaromic, peritepal, CT, etc.). There is no restriction regarding the speciality, all digital images, videos, and documents can be exchanged | Current solution is sized @ 750 K exams/Year, connecting around 234 Modalities (CT/MR/XR/US/MG/ NM/PET-CT/CATH-LAB and US Cardio)   | DHA generates approximately 1.5 million studies per year, from multiple modalities, including DR, ultrasound, CT, MRI, PET-CT, Cathlab, Echo, Fundus Cameras, and ECGs  | We are currently only sharing ECG's (in SVG format) and proposed to also share DICOM images using FHIR HL7. Once a national DICOM is in place, all the modalities able to give DICOM output will be covered. For Non-DICOM output like some cameras can be converted to DICOM and uploaded. We have certain programs already developed for the same. We have already put up a small solution to share mammography images between 5 and 6 hospitals for a national program to utilize artificial intelligence to detect breast cancer. We have also put up a small solution to share CT and MRI images between 2 and 3 hospitals for an expert opinion. We envisage more than 75 TB of data to be generated per year from both government and private sectors |



| # | Questions (Q)  | Answer by:<br>Turkish Healthcare Service (Government Service)—Turkey<br>((Universal and private healthcare services)   | Answer by:<br>Ministry of Health (Government Services) – UAE (Dubai)- Platform One<br>((Universal and private healthcare services) | Answer by:<br>Ministry of Health (Government Services) – UAE (Dubai)- Platform Two<br>((Universal and private healthcare services)                                       | Answer by:<br>Ministry of Health (Government Service)—Oman<br>((Universal and private healthcare services)   |
|---|--|--|--|--|--|
| 3 | What type of standard is used for exchange? (DICOM, IHE-Profiles, or other)  | NTS uses HL7, DICOM, and XDS standards and implements following integrating healthcare enterprise (IHE) profiles: cross-enterprise document sharing for imaging (XDS-I.b), cross-enterprise clinical documents share (XDS.b), cross-community access for imaging, consistent presentation of images access to radiology information, consistent time, audit trail and node authentication, mammography image, radiation exposure monitoring, scheduled workflow. b, teaching file, and clinical trial export | DICOM for images and HL7 for reports   | DHA is a JCI standards driven organization that manages workflows and image exchange through IHE profiles and DICOM (Store/Worklist/MPPS)                                | DICOM and HL7 FHIR will be used  |
| 4 | Does the exchange is for image or for both image and report?   | The exchange is for both images and their reports  | Images and reports   | Both images and reports  | We do not share reports in PACS as they are part of medical record of the patient in the local HIS, AISHifa, and as part of the national e-health repository NEHR AISHifa<br>But any DICOM report rendered by the modality can be part of it |
| 5 | What type of image specialties are exchanged (radiology, cardiology, dental, ophthalmology, dermatology, pathology, etc.)? | Most common specialties are Radiology (MR, CT, X-Ray, mammography, ultrasound etc.), cardiology (ultrasound, ECG, angiography, etc.), Dental (panaromic, peritpepal, CT, etc.). There is no restriction regarding the specialty; all digital images, videos and documents can be exchanged   | Currently radiology and cardiology and dental is planned for the near future   | Radiology, cardiology, nuclear medicine, dental, and ophthalmology with plans to extend the enterprise imaging platform to manage imaging data generated by all 'ologies | Currently, except pathology, all radiology, cardiology, dental, ophthalmology, etc. can be considered to be done   |

| # | Questions (Q)  | Answer by:<br>Turkish Healthcare Service (Government Service)—Turkey<br>((Universal and private healthcare services)) | Answer by:<br>Ministry of Health (Government Services) – UAE (Dubai)- Platform One<br>((Universal and private healthcare services))  | Answer by:<br>Ministry of Health (Government Services) – UAE (Dubai)- Platform Two<br>((Universal and private healthcare services))   | Answer by:<br>Ministry of Health (Government Service)—Oman<br>((Universal and private healthcare services)) |
|---|--|---|--|---|---|
| 6 | <p>What are the five top challenges that you are facing while such image exchange is in place?</p> <p>(1) Due to XDS-I architecture, overall availability of the system depends on the availability of image retrieval services at 2014 hospitals. Possible interruptions of these independent services reduce uptime</p> <p>(2) Although there are services for patient information reconciliation, data update and data removal, which can be used by image and document sources (i.e., PACS and HIS systems), there is no implementation for continuously verifying patient data existing in the source, which leaves the integrity of the provided data to the discretion of the sources</p> <p>(3) Retrieval of images depends on the bandwidths of both source and consumer hospitals. Since the connection speeds and line occupancies vary, a quality of service regarding the speed cannot be guaranteed</p> <p>(4) Keeping the micro-services which get millions of requests everyday fast, secure and up requires highly skilled, dedicated and motivated experts. Management of such a team is a challenge itself</p> <p>(5) Since the web-based application is used by millions of citizens and thousands of physicians on different types of devices such as PCs, tablets, and cell phones, the development team must keep the application compatible with different hardware, operating system and browser combinations</p> | <p>Typically other systems readiness to comply with IHE standards like XDS compliance</p>                             | <ul style="list-style-type: none"> <li>• Movement from imaging silos to an imaging IT platform</li> <li>• Defining roles and responsibilities between clinical departments and IT department</li> <li>• Demonstrating ROI to executive management</li> <li>• Incorporating additional medical providers into the exchange platform</li> <li>• Providing remote access to stakeholders while adhering to security requirements</li> </ul> | <p>Even though we do not share currently have a national exchange of images, we have faced the following challenges with the limited work we have done</p> <ol style="list-style-type: none"> <li>1. National network infrastructure is improving but for images, it requires all institutions to be on higher and faster network infrastructure</li> </ol> <p>Currently, we have a government wide shared MPLS line with all the government ministries and their services utilizing the same bandwidth</p> <ol style="list-style-type: none"> <li>2. Lack of National DICOM archive</li> <li>3. Lack of National Retention &amp; Management</li> <li>Policy means images are never deleted</li> <li>4. Lack of local PACS in many institutes though it is improving</li> <li>5. Lack of staffing at current levels to manage the national project</li> </ol> |   |

| #  | Questions (Q)   | Answer by:<br>Turkish Healthcare Service (Government Service)—Turkey<br>((Universal and private healthcare services))  | Answer by:<br>Ministry of Health (Government Services) – UAE (Dubai)- Platform One<br>((Universal and private healthcare services))   | Answer by:<br>Ministry of Health (Government Services) – UAE (Dubai)- Platform Two<br>((Universal and private healthcare services)) | Answer by:<br>Ministry of Health (Government Service)—Oman<br>((Universal and private healthcare services))   |
|----|---|--|---|---|---|
| 7  | Is there any governance committee and policy in place to run such image exchange?   | The National Telemedicine System is governed by MoH General Directorate for Information Systems. The regional systems are governed by regional directorships. Policies are as follows:<br>(1) All exchange must comply with the “Law on the Protection of Personal Data”<br>(2) Radiology examinations that will be invoiced to social security agency (In Turkey, teher is a universal coverage for medical services) must first be transmitted to telemedicine. Invoices cannot be issued for examinations that are not transmitted to the telemedicine system (That is, all radiological examinations MUST be sent to national telemedicine system unless paid as out of pocket)<br>(3) Other policies are as follows: telemedicine integration guidelines, telemedicine workflow chart, telemedicine XDS integration guidelines, registered ICD10/Clinical/Angro/LOINC/SUT codes | Yes but unfortunately not on the federal level e.g., SEHA with Malaffi and DHA with Nabel and MOH standalone and No integration between the three organizations                 | Typically, the image exchange is managed on a departmental basis with general oversight from the Diagnostic Imaging department      | Directorate General of information technology under the Ministry of Health is currently the one implementing the policy and running the medical data exchange   |
| 8  | Is there any plan to have Medical Image Exchange in case such an exchange platform does not exist?                                  | N/A  | UAE has mainly two platforms which are partially ready like Malaffi and Nabel but none of them is ready with the image exchange and currently integration is limited to reports |   | Yes, it is under planning in the ministry   |
| 9  | Is there any integration between EMR/HIS and image PACS and or Medical Image Exchange solution?                                     | EMR/HIS, PACS, and Medical Exchange solution are fully integrated  | Yes, HIS/EMR across MOH   | DHA has a single point of integration between the installed EMR and the Enterprise Imaging Platform                                 | Yes currently many institutes have a type of PACS installation, be it Mini-PACS or Full PACS but they are all integrated to the local HIS/EMR AISHifa as our HIS/EMR are deployed locally<br>The national e-health repository is envisaged to also have this integration using FHIR HL7 |
| 10 | In case of Medical Image Exchange in place, what type of viewer is used? And is it EMR/HIS viewer or Medical Image Exchange viewer? | It is the medical image exchange's viewer that may also be reached under EMR/HIS   | ZFP which is the universal viewer across MOH and embedded within HIS application  | The viewer is embedded within the EMR   | Since we do not have a Medical Image Exchange at present we cannot answer this but we envisage a Zero footprint HTML5 viewer for the purpose  |

| #  | Questions (Q)   | Answer by:<br>Turkish Healthcare Service (Government Service)—Turkey<br>((Universal and private healthcare services)) | Answer by:<br>Ministry of Health (Government Services) – UAE (Dubai)- Platform One<br>((Universal and private healthcare services))  | Answer by:<br>Ministry of Health (Government Services) – UAE (Dubai)- Platform Two<br>((Universal and private healthcare services))   | Answer by:<br>Ministry of Health (Government Service)—Oman<br>((Universal and private healthcare services))  |
|----|---|---|--|---|--|
| 11 | How does organization management perceive Medical Image Exchange importance? Is it more or less than exchanging EMR/HIS data? | It gives an equal importance to EMR/HIS data  | They see the importance but politically cannot admit that connecting the 3 systems is required   | Importance is perceived as significantly less than exchanging EMR/HIS data  | The MOH perceives it highly  |
| 12 | What do you exchange currently across your organization chain?  | Demographic data, medical images, reports, laboratory parameters, etc   | Using secure image sharing provided within our current PACS, we exchange imaging DICOM data with our patients or their referring physicians following a strict SOP to securely authorize any such activity | Balancing the Workload across MOH hospitals and clinics, leveraging specialized resources (Pediatric And Neuro Rad)<br>This PPP medical image exchange platform delivered a positive transformation in radiology. It aims to deliver the highest possible imaging services to patients at the highest diagnostic quality, to enable the best patient outcomes across UAE from independent geographical locations<br>The main challenges faced the project as follows:<br><ul style="list-style-type: none"> <li>• Out-dated, localized film-based (analogue) imaging in hospitals</li> <li>• Wide geographic region means physical transportation of images is expensive, insecure and slow</li> <li>• Radiologist skill shortages across the region</li> <li>• Long patient waiting times for scans and reports</li> <li>• Expected increase in patients putting pressure on waiting lists</li> <li>• Finding or filing of hardcopy patient image records is slow with an image quality impact</li> <li>• Archives take up hospital space and require specialist temperature control monitoring</li> </ul> | All patient data is securely exchanged throughout the Enterprise<br>Currently, we have NEHR AShifa for exchanging the complete medical data and e-Referral for referring a patient across institutions<br>We have put up a small solution to share mammography images between 5 and 6 hospitals for a national program to utilize Artificial Intelligence to detect breast cancer<br>We have also put up a small solution to share CT & MRI images between 2 and 3 hospitals for an expert opinion |

## Saudi Arabia

## (Universal and private healthcare services)

| # | Questions (Q)  | Answer by:<br><b>Al Habib Medical Group (HMG, Private Group)</b>   | Answer by:<br><b>Security Forces Hospital (Government Service)</b>             | Answer by:<br><b>National Guard Health Services (Government Service)</b>                                  | Answer by:<br><b>Ministry of Health (Government Service) Saudi Arabia</b>   |
|---|--|--|--|---|---|
| 1 | Is there Medical Image Exchange platform or solution that covers a chain of hospitals or regional or national level?                               | National level as we are supporting centralize system for all HMG branches in Saudi Arabia   | Yes, hospital to primary clinics   | There is Medical Image Exchange platform covering multi hospitals in different region                     | Yes there are multi platforms for image exchange such as Cardiology (covering 8 centers), Radiology (covering 30 hospitals for Tele-Radiology), 200 k mammo screening studies per year in place and under implantation for dental to cover 3000 dental clinics. More projects are coming soon in that direction |
| 2 | If so, how many studies and or images will be exchanged per year? And what size of? And are all modalities covered? And which modality is covered? | Around 900 K images are exchanged per year for all radiology modalities (X-RAY, CT, MRI, US, MAMO, BMD, PET and SPECT) across the MIE platform. <<<This is better thanks for providing details per modality per hospital across the group! | > 10 K exams, X-ray modality   | More than 1,000,000 studies/year. The size of all hospitals around 3500 bed, All modality connected       | Over all MOH does 10 million studies per year of radiology. The scale is large also for rest  |
| 3 | What type of standard is used for exchange? (DICOM, IHE-Profiles, or other)  | DICOM standard for store images<br>HL7 standard for reporting  | DICOM for Images, XDS for Reports and IHE-Profiles                             | DICOM & IHE Profiles (such as XDS)  | DICOM & IHE Profiles (such as XDS)  |
| 4 | Does the exchange is for image or for both image and report?   | Yes, both images and reports   | Yes  | Both  | Yes covering both Image and report  |
| 5 | What type of image specialties are exchanged (Radiology, Cardiology, Dental, ophthalmology, Dermatology, pathology, etc.)?                         | Radiology<br>Cardiology<br>Genecology<br>Urology<br>Orthopedic<br>Neurology<br>Endoscopy (ongoing project)<br>Dental<br>Ophthalmology (ongoing project)<br>Surgery (ongoing)<br>Oncology   | Radiology  | The following specialties:<br>Radiology,<br>ophthalmology,<br>Dermatology,<br>endoscopy                   | Today covers radiology, cardiology, mammo screening and dental. In the near future will expand into pathology, ophthalmology, and others  |
| 6 | What are the five top challenges that you are facing while such image exchange is in place?  | Image storage capacity<br>Network performance when Transmitting Images<br>Register patient manually in modality and send to PACS<br>DAS/DMWL Services availability<br>Changing IP address, AET and DICOM Attributes                        | - Governance<br>- Resource<br>- Subspecialty<br>- Strategy<br>- Old modalities | 1- Standardization<br>2-Venders corporation<br>3-Expertise resources<br>4-Network bandwidth<br>5-Slowness | 1-Enterprise Imaging Governance to be in place<br>2-Infrastructure that could accommodate such large volume<br>3-Adaption to use one ZFP viewer<br>4-Integration with EMRs especially the legacy ones   |

## Saudi Arabia

## (Universal and private healthcare services)

| #  | Questions (Q)   | Answer by:<br><b>Al Habib Medical Group (HMG, Private Group)</b>   | Answer by:<br><b>Security Forces Hospital (Government Service)</b>   | Answer by:<br><b>National Guard Health Services (Government Service)</b> | Answer by:<br><b>Ministry of Health (Government Service) Saudi Arabia</b>        |
|----|---|--|--|--|--|
| 7  | Is there any governance committee and policy in place to run such image exchange?   | Yes, there is policy applied for Medical Imaging Exchange  | No   | Yes  | Yes, on level of one ology but not on enterprise level                           |
| 8  | Is there any plan to have Medical Image Exchange in case such an exchange platform does not exist?                                  | As mentioned in Q1, We already have existing Medical imaging exchange platform   | Yes  | Already existed  | The plan is continue enhancing the existing ones and expand                      |
| 9  | Is there any integration between EMR/HIS and image PACS and or Medical Image Exchange solution?                                     | Yes, Medical Imaging system (RIS) integrated with HIS  | YES by HIE system  | Yes, we have fully integration system including all systems              | Yes  |
| 10 | In Case of Medical Image Exchange in place, what type of viewer is used? And is it EMR/HIS viewer or Medical Image Exchange viewer? | Medical Image viewer and OpenAPI configured to view images from HIS calling Patient ID or Accession number   | Medical Image Exchange viewer (ZFP) <a href="https://zfp.sfh.med.sa/ZFP/patientTimeline">https://zfp.sfh.med.sa/ZFP/patientTimeline</a>  | Throughout ZFP viewer on EMR   | WADO, ZFP, EMR-Viewer  |
| 11 | How does organization management perceive Medical Image Exchange importance? Is it more or less than exchanging EMR/HIS data?       | It is supporting the huge operation of the group while satisfying the highest healthcare quality dimensions; safety, effectiveness, time, efficiency and equitability<br>Medical Image exchange is important as EMR/HIS data, complement each other in the healthcare eco-system | Centralized all Patients files and accessible from anywhere (patient portal and tele system) <a href="https://digitalhealth.sfh.med.sa/PO/pages/login.aspx">https://digitalhealth.sfh.med.sa/PO/pages/login.aspx</a> | They are support both at the same level                                  | Medical imaging exchange is as important as EMR data. They complement each other |

## Saudi Arabia

## (Universal and private healthcare services)

| #  | Questions (Q)  | Answer by:<br>Al Habib Medical<br>Group (HMG,<br>Private Group)  | Answer by:<br>Security Forces<br>Hospital<br>(Government<br>Service) | Answer by:<br>National Guard<br>Health Services<br>(Government<br>Service)                                 | Answer by:<br>Ministry of Health<br>(Government Service)<br>Saudi Arabia   |
|----|--|--|--|--|--|
| 12 | What do you exchange currently across your organization chain? | In terms of medical information; all type of data (processed and raw) are exchanged across the group medical network; HIS/RIS/LIS/PACS | Radiology Image and Report   | It is managed at one centralize patient record include all patient data and access across all organization | <p>Both image and report<br/>And here is example of MOH Cardiology Image Exchange Platform Use Cases:</p> <p><b>Use case 1:</b><br/><b>Centralized data management and governance:</b><br/>Study created &amp; reported locally, all studies and reports sent to the Central VNA communicated back to other hospitals<br/> <ul style="list-style-type: none"> <li>✓ All images produced at local sites are copied to the central VNA and stored according certain rules</li> <li>✓ Reports are copied to the central XDS repository and stored in standard CDA format, which will be recorded referenced in the Central IHE-Index to the patient identifier of the patient domain based on the Patient ID Assigning Authority send in the HL7 ORU message PID segment</li> </ul> </p> <p><b>Use case 2:</b><br/><b>Cross Hospital reporting utilizing Central VNA:</b><br/>Study created at Hospital A, reported by physician at Hospital B using the Central VNA<br/> <ul style="list-style-type: none"> <li>✓ Image is sent to Central VNA through DICOM send</li> <li>✓ Report at Riyadh Central VNA is created and finalized</li> <li>✓ Study and report are published to XDS and replaces original study</li> </ul> </p> <p><b>Use case 3:</b><br/><b>Cross Hospital reporting between two hospitals using XDS:</b><br/>Study created at Hospital A, reported by physician at Hospital B using XDS functionality<br/> <ul style="list-style-type: none"> <li>✓ Study transferred to Central VNA by Hospital A</li> <li>✓ Physician from hospital B select study to be reported and fetch from Central VNA takes place via XDS</li> <li>✓ Study is reported and finalized at Hospital B and replaces the original study from hospital A</li> </ul> </p> <p><b>Use case 4:</b><br/><b>Reporting from physician's Home:</b><br/>Study created at Hospital A, reported by physician from Hospital A from home<br/> <ul style="list-style-type: none"> <li>✓ Study images acquired at Hospital A</li> <li>✓ Physician at home searches for patient and select study worklist for reporting</li> <li>✓ After finalizing the report, Images are auto-forwarded to Central VNA</li> <li>✓ Study and report are published to XDS and replaces original study</li> </ul> </p> <p><b>Use case 5:</b><br/><b>External DICOM study import in Hospital A:</b><br/> <ul style="list-style-type: none"> <li>✓ Study created from external source, imported by physician at Hospital A</li> <li>✓ Various profiles for study import <ul style="list-style-type: none"> <li>o Reporting of a study provided on CD/DVD</li> <li>o Second opinion on a study provided on CD/DVD</li> <li>o Study provided on (CD/DVD) for a referred patient</li> <li>o Old Study provided by (CD/DVD) which was requested for comparison</li> </ul> </li> </ul> </p> |

## References

1. <https://hmg.com/en/Pages/home.aspx>
2. [www.sfh.med.sa](http://www.sfh.med.sa)
3. <https://www.ngha.med.sa/English/Pages/default.aspx>
4. [www.moh.gov.sa](http://www.moh.gov.sa)
5. <https://www.moh.gov.om/en/home>
6. <https://www.mohap.gov.ae/en/Pages/default.aspx>
7. GE Healthcare - UAE MOH.pdf
8. [DIAM\\_Insights into Imaging.pdf](#)
9. <https://www.himss.org/what-we-do-solutions/digital-health-transformation/maturity-models/digital-imaging-adoption-model-diam>
10. <https://link.springer.com/article/10.1007/s10278-019-00294-0>
11. <https://www.myesr.org/quality-safety/digital-imaging-adoption-model-diam>
12. <https://malaffi.ae/what-is-malaffi/about-malaffi/>

**Publisher's Note** Springer Nature remains neutral with regard to jurisdictional claims in published maps and institutional affiliations.

Springer Nature or its licensor holds exclusive rights to this article under a publishing agreement with the author(s) or other rightsholder(s); author self-archiving of the accepted manuscript version of this article is solely governed by the terms of such publishing agreement and applicable law.

## Authors and Affiliations

Monief Eid<sup>1</sup>  · Mosa Al Mutairi<sup>2</sup> · Hakki M. Karakas<sup>3,4,5</sup> · Usama Mohammad Hassan Al Bastaki<sup>6</sup> · Abdulaziz Abdulrahman Nasser Almosabihi<sup>7</sup> · Adel Abdulkader Tash<sup>8</sup> · Nasser Mohammed Al Huqbani<sup>9</sup> · Abdulelah Abdulrahman AlMayman<sup>10</sup> · Alabbas Nasser Albarakati<sup>10</sup> · Reem AlRakaf<sup>11</sup> · Mohammed Othman Alomair<sup>12</sup> · Bader Awladthani<sup>13</sup>

Mosa Al Mutairi  
MutairiM@ngha.med.sa

Hakki M. Karakas  
hakki.karakas@cureatech.com

Usama Mohammad Hassan Al Bastaki  
UMALBastaki@dha.gov.ae

Abdulaziz Abdulrahman Nasser Almosabihi  
AAL-MOSABAHI@moh.gov.sa

Adel Abdulkader Tash  
Atash@moh.gov.sa

Nasser Mohammed Al Huqbani  
Abbas.barakati@cloudsolutions.com.sa

Abdulelah Abdulrahman AlMayman  
huqbanin@drsulaimanalhabib.com

Alabbas Nasser Albarakati  
abdulelah.almayman@cloudsolutions.com.sa

Reem AlRakaf  
ralrakaf@moh.gov.sa

Mohammed Othman Alomair  
malomair@sfh.med.sa

Bader Awladthani  
bader.awladthani@moh.gov.om

<sup>1</sup> Enterprise Imaging & eHealth Senior Consultant, Victoria, BC, Canada

<sup>2</sup> King Abdulaziz Medical City – Riyadh (KAMC-R), Riyadh, Saudi Arabia

<sup>3</sup> Imaging Services, Istanbul Health Authority, Istanbul, Turkey

<sup>4</sup> Curea, Istanbul, Turkey

<sup>5</sup> Neurometrika-Tech, Istanbul, Turkey

<sup>6</sup> Diagnostic Imaging Department, DHA, Dubai, United Arab Emirates

<sup>7</sup> Radiology and Allied Services, Ministry of Health, Riyadh, Saudi Arabia

<sup>8</sup> National Heart Center, Riyadh, Saudi Arabia

<sup>9</sup> Dr. Sulaiman Al Habib Medical Group, Riyadh, Saudi Arabia

<sup>10</sup> Cloud Solutions for Communication and IT, Riyadh, Saudi Arabia

<sup>11</sup> Women Health Program, Ministry of Health, Riyadh, Saudi Arabia

<sup>12</sup> Security Forces Hospital, Riyadh, Saudi Arabia

<sup>13</sup> Information Technology, Ministry of Health, Muscat, Oman