

## Obstructions to Shiftedness\*

Caroline Klivans

Computing and Information Science, Cornell University,  
Ithaca, NY 14853, USA  
cjk11@cornell.edu

**Abstract.** In this paper we show results on the combinatorial properties of shifted simplicial complexes. We prove two intrinsic characterization theorems for this class. The first theorem is in terms of a generalized vicinal preorder. It is shown that a complex is shifted if and only if the preorder is total. Building on this we characterize obstructions to shiftedness and prove there are finitely many in each dimension. In addition, we give results on the enumeration of shifted complexes and a connection to totally symmetric plane partitions.

### 1. Introduction

A simplicial complex on  $n$  nodes is shifted if there exists a labeling of the nodes by 1 through  $n$  such that for any face  $\{v_1, v_2, \dots, v_k\}$ , replacing any  $v_i$  by a node with a smaller label results in a collection which is also a face. Shifted complexes have been considered in various contexts. For example, they are the class of complete simple games in game-theory [17].

A primary motivation for the study of shifted complexes is the fact that any simplicial complex can be transformed into a shifted complex in a way which preserves meaningful information. Shifting operations were first introduced by Erdős et al. [3] and Kleitman [9]. See [4] for a survey on this operation in hypergraph and extremal set theory. Later, Kalai introduced the notion of algebraic shifting [6], [7]. Algebraic shifting preserves certain properties of a complex while simplifying others. For example, shifting preserves the  $f$ -vector of a complex, but the topology is always reduced to a wedge of spheres. Shifting has proved to be a successful tool for answering questions regarding  $f$ -vectors, see for example [1] and [12]. For a survey on algebraic shifting, see [8].

---

\* The work here was done while the author was a graduate student at MIT and partially supported by an NSF graduate research fellowship.

Another motivation for the study of shifted complexes is their connection to threshold graphs. One-dimensional shifted complexes are exactly the threshold graphs. These graphs have been extensively studied [11] and this connection provides many insights into the structure of shifted complexes. We first extend a characterization of threshold graphs in terms of the vicinal preorder by defining a generalized vicinal preorder for simplicial complexes of any dimension. Our result shows that a complex is shifted if and only if the generalized preorder is total. Building on this, we arrive at a second characterization for shifted complexes in terms of obstructions. We give the range of the number of nodes on which there exist obstructions to shiftedness. In particular, we show that there exists a finite number of obstructions to shiftedness in each dimension. Next, we consider the enumeration of shifted complexes. We provide the number of two-dimensional shifted complexes by giving a very simple bijection between these complexes and totally symmetric plane partitions. Finally, we give the first few entries of the number of pure shifted complexes.

## 2. Definitions and Examples

**Definition 1.** A simplicial complex on  $n$  nodes is shifted if there exists a labeling of the nodes by 1 through  $n$  such that for any face  $\{v_1, v_2, \dots, v_k\}$ , replacing any  $v_i$  by a node with a smaller label results in a collection which is also a face.

An equivalent definition of shifted complexes is in terms of order ideals. An *order ideal*  $I$  of a poset  $P$  is a subset of  $P$  such that if  $x$  is in  $I$  and  $y$  is less than  $x$  in the partial order, then  $y$  is in  $I$ . Consider the partial ordering on strings of increasing integers where  $(x_1 < x_2 < \dots < x_k)$  is taken to be less than  $(y_1 < y_2 < \dots < y_k)$  if  $x_i \leq y_i$  for all  $i$ . Shifted complexes are exactly order ideals in this poset, see Fig. 1.

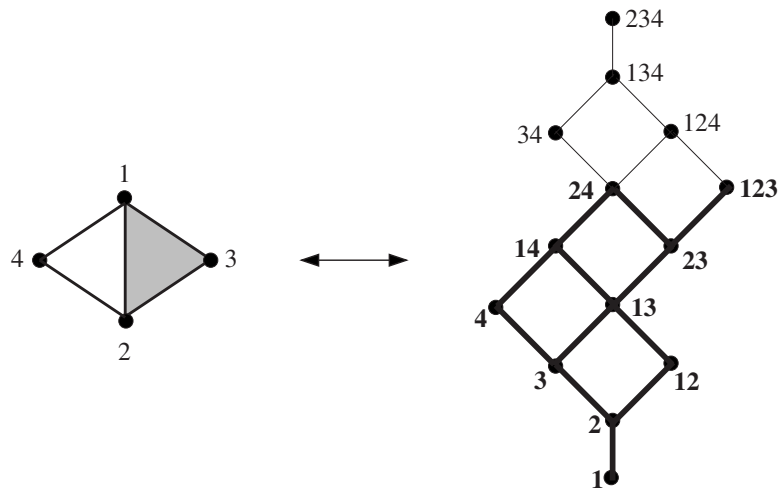

Fig. 1. An example of a shifted complex.

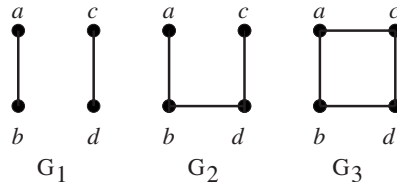

Fig. 2. Non-shifted complexes.

Let us consider some complexes that are not shifted. We can easily see that the graphs of Fig. 2 are not shifted. For example, in  $G_1$  let node  $a$  have label 1. Then the label of  $c$  must be larger than the label of  $a$ . So we should be able to replace  $c$  with  $a$  in the collection  $\{c, d\}$  and have a face of the complex. However,  $\{a, d\}$  is not a face. Therefore  $G_1$  is not shifted, and we could similarly prove  $G_2$  and  $G_3$  are not shifted. These three graphs are actually all of the obstructions to shiftedness in dimension one. This result is a consequence of the connection between shifted complexes and threshold graphs.

### 3. Threshold Graphs

An *independent set* of a graph is a collection of nodes no two of which are connected by an edge.

**Definition 2.** A graph is threshold if for all  $v \in V$  there exists weights  $w(v)$ , and  $t \in \mathbb{R}$  such that the following condition holds:  $w(U) \leq t$  if and only if  $U$  is an independent set, where  $w(U) = \sum_{v \in U} w(v)$  (see Fig. 3).

Threshold graphs are an extensively studied class of graphs, see for example [5] or [11]. There are many equivalent characterizations of these graphs. Here we look at some of these characterizations and their generalizations due to the fact that *one-dimensional shifted complexes are exactly the threshold graphs*. Hence shifted complexes are a generalization of this class of graphs. In [5] many generalizations of threshold graphs to hypergraphs are considered, only some of these concepts correspond to shifted complexes.

Above we claimed that  $G_1$ ,  $G_2$ , and  $G_3$  are all the obstructions to shiftedness in dimension one. This statement is simply a translate of the following result.

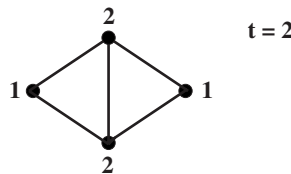

Fig. 3. A threshold graph with threshold 2.

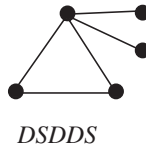

Fig. 4. A threshold graph with its construction.

**Theorem [11].** *A graph is threshold if and only if it does not contain  $G_1$ ,  $G_2$ , or  $G_3$  as an induced subgraph.*

Threshold graphs can also be described constructively in terms of two basic operations. Let  $D$  stand for adding a disjoint node. Let  $S$  stand for starring a node, namely placing a new node adjacent to all previous nodes of the graph (see Fig. 4).

**Theorem [11].** *Threshold graphs are exactly those graphs formed from the empty graph by successive applications of the operations  $D$  and  $S$ .*

The last characterization we look at here is in terms of the vicinal preorder. First, we recall the definition of the vicinal preorder for graphs, which we call the 1-vicinal preorder for convenience later on. For any simple graph  $G$  and any node  $v \in G$ , let  $N_1(v) = \{w \in G \mid vw \in G\}$  and  $N_1[v] = N_1(v) \cup \{v\}$ . Note that  $N_1(v)$  is just the usual neighborhood of a vertex of a graph.

**Definition 3** (1-Vicinal Preorder  $\succsim_1$ ). Let  $x \succsim_1 y$  if and only if  $N_1[x]$  contains  $N_1(y)$ .

**Theorem [11].**  *$G$  is a threshold graph if and only if the vicinal preorder of  $G$  is total.*

In the example of Fig. 5, the graph has been labeled with a shifted labeling. Notice that the shifted labeling is exactly opposite the vicinal order. This is true in general, so once we determine the vicinal ordering of a graph, we may obtain a shifted labeling.

#### 4. Characterizations

First we extend the characterization of threshold graphs in terms of the vicinal preorder. We have for any one-dimensional simplicial complex  $K$ ,  $K$  is shifted if and only if the

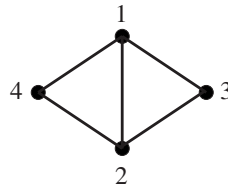

Fig. 5. A threshold graph with vicinal preorder:  $4 \sim_1 3 <_1 2 \sim_1 1$ .

1-vicinal preorder of  $K$  is total. In order to generalize this result, we need the concept of a vicinal preorder for general simplicial complexes, not just graphs. The *star* of a vertex  $v$  of a simplicial complex is the set of faces of the complex which contain  $v$ . The *link* of a vertex  $v$  of a simplicial complex  $K$  is the set of faces of the star( $v$ ) which do not contain  $v$ . Namely, the link of a vertex  $v$  is equal to the set of faces  $\{f \in K \mid f \cup v \in K \text{ and } v \notin f\}$ . For a  $d$ -dimensional simplicial complex  $K$ , and  $v$  a node in  $K$ , let  $N_d(v) = \{(d-1)\text{-dimensional faces of the link}(v)\}$  and  $N_d[v] = \{(d-1)\text{-dimensional faces of the star}(v)\}$ . Note that for  $d = 1$   $N_d(v)$  and  $N_d[v]$  are the same as in the graphical case.

**Definition 4** ( $d$ -vicinal preorder  $\succsim_d$ ). Let  $x \succsim_d y$  if and only if  $N_d[x]$  contains  $N_d(y)$ .

We need to check that this is a preorder, namely that it is reflexive and transitive. Reflexivity requires that  $N_d[x] \supseteq N_d(x)$ , which is true by definition. Transitivity requires that  $N_d[x] \supseteq N_d(y)$  and  $N_d[y] \supseteq N_d(z)$  imply  $N_d[x] \supseteq N_d(z)$ . Suppose  $yz \notin K$ . Then  $N_d(z) \subseteq N_d(y) \subseteq N_d[x]$ . If  $yz \in K$ , then for some face  $f$ ,  $yf \in N_d(z)$ . We must show  $yf \in N_d[x]$ . We have

$$\begin{aligned} yf \in N_d(z) &\Rightarrow zf \in N_d(y) \\ &\Rightarrow zf \in N_d(x) \\ &\Rightarrow xf \in N_d(z) \\ &\Rightarrow xf \in N_d(y) \\ &\Rightarrow yf \in N_d(x). \end{aligned}$$

**Theorem 1.** For a pure  $d$ -dimensional simplicial complex  $K$ ,  $K$  is shifted if and only if the  $d$ -vicinal preorder is total.

*Proof.* ( $\Rightarrow$ ) Suppose  $K$  is shifted and the  $d$ -vicinal preorder is not total.

This implies there exist nodes  $x, y \in K$  such that  $x$  and  $y$  are incomparable. Then we have  $N_d[x] \not\supseteq N_d(y)$  and  $N_d[y] \not\supseteq N_d(x)$ . Hence there exist faces  $f_1$  and  $f_2$  such that  $xf_1 \in K$ ,  $yf_1 \notin K$  and  $yf_2 \in K$ ,  $xf_2 \notin K$ . Let  $l$  be a shifted labeling for  $K$ . Without loss of generality, we may assume  $l(x) < l(y)$ . Then  $yf_2 \in K$  implies  $xf_2 \in K$ , a contradiction.

( $\Leftarrow$ ) Suppose the  $d$ -vicinal preorder is total. Label the nodes of  $K$  in non-increasing order with respect to the vicinal preorder. We claim this is a shifted labeling. Consider any face  $(x_1, x_2, \dots, x_{d+1}) \in K$  and any node  $w$  such that  $l(w) < l(x_i)$  for some  $i$ . Since the labeling is non-increasing,  $N_d[w] \supseteq N_d(x_i)$  implies  $(x_1, x_2, \dots, \hat{x}_i, \dots, x_{d+1}) \in N_d[w]$  which implies  $(w, x_1, x_2, \dots, \hat{x}_i, \dots, x_{d+1}) \in K$ .  $\square$

This is our first intrinsic look at shifted complexes of dimension greater than one. However, it is restricted to pure complexes. It is tempting to think that a complex is shifted if each skeleton is shifted, where the  $i$ th skeleton is the collection of all  $i$ -dimensional faces. It is important to point out that having all the vicinal preorders total does **not** imply shiftedness. For example, consider the simplicial complex with maximal faces =  $\{abc, ad, ae, cd, ce, de\}$  (see Fig. 6). Both the 1- and 2-vicinal preorders

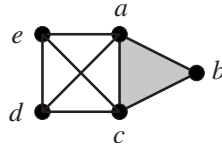

Fig. 6. A non-shifted complex with both preorders total.

are total,

$$\begin{aligned}
 a \sim_1 c \succ_1 e \sim_1 d \succ_1 b, \\
 a \sim_2 b \sim_2 c \succ_2 e \sim_2 d
 \end{aligned}$$

but the complex is not shifted. On the other hand, for a complex to be shifted, we do need that the preorders are total. What still may be missing is a single labeling which is a shifted labeling in all dimensions. Any shifted labeling must label the nodes in non-increasing order with respect to all preorders. Otherwise, we would have two nodes,  $x$  and  $y$ , such that  $l(x) < l(y)$  but  $y \succ_i x$  for some  $i$ . This means  $N_i[y] \supset N_i(x)$  with strict containment. Therefore we would have  $yf \in K$  but  $xf \notin K$  for some face  $f$ , showing  $K$  is not shifted. Thus we see that for a complex to be shifted it must have all preorders total *and* a labeling which is non-increasing with respect to them all. This means that two nodes  $x$  and  $y$  may be equivalent in one preorder and have one larger than the other in another preorder. However,  $x$  cannot be greater than  $y$  in one preorder and then smaller than  $y$  in another. In Fig. 7 we have  $a \sim_1 b \succ_1 c \sim_1 d$  and  $a \sim_2 b \sim_2 c \succ_2 d$ .

Next we use the vicinal preorder characterization to describe obstructions to shiftedness. We consider an obstruction to shiftedness to be a non-shifted simplicial complex, all of whose induced subcomplexes are shifted. Recall that threshold graphs can be characterized in terms of forbidden induced subgraphs (see Fig. 2). Our goal is to characterize shifted complexes in terms of forbidden induced subcomplexes. For a complex to be shifted it must be shifted in all dimensions and we may easily check if the 1-skeleton of a complex is shifted. Therefore in general, when we consider the  $d$ -dimensional case, we allow ourselves to assume the  $(d - 1)$ -skeleton is shifted.

**Theorem 2.** *In  $d$  dimensions all obstructions to shiftedness with shifted  $(d - 1)$ -skeleton are on  $(d + 3) \leq n \leq (2d + 2)$  nodes, and there exist obstructions on each of these values.*

*Proof.* Let  $K$  be a  $d$ -dimensional obstruction with shifted  $(d - 1)$ -skeleton on  $n > (2d + 2)$  nodes.

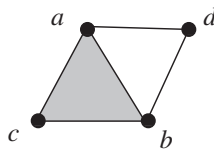

Fig. 7. A shifted complex with different but compatible preorders.

*Case 1: The  $d$  skeleton of  $K$  is not shifted.* Then the  $d$ -vicinal preorder is not total. This is the case if and only if there exist  $x, y \in K$  such that  $x$  and  $y$  are incomparable. Again this is equivalent to  $N_d[x] \not\supseteq N_d(y)$  and  $N_d[y] \not\supseteq N_d(x)$ . Hence we have  $(d - 1)$  faces  $e_1$  and  $e_2$  such that  $xe_1 \in K, ye_1 \notin K$  and  $ye_2 \in K, xe_2 \notin K$ . The number of nodes in  $\{x, y, e_1, e_2\}$  is at least  $(d + 3)$  and at most  $(2d + 2)$ . Since  $n > (2d + 2)$ , there must exist a node  $a$ , not equal to  $x$  or  $y$  and not in  $e_1$  or  $e_2$ . Removing  $a$  from  $K$  clearly cannot affect  $xe_1, ye_1, ye_2,$  or  $xe_2$ . This implies the  $d$ -vicinal preorder is not total on  $K \setminus a$ . Therefore  $K \setminus a$  cannot be shifted, which contradicts that  $K$  is an obstruction.

*Case 2: The  $d$  skeleton of  $K$  is shifted.* Then we know all preorders are total. Since  $K$  is not shifted, there is no labeling of the nodes which is non-increasing with respect to all of them. We have assumed the  $(d - 1)$  skeleton is shifted, therefore it is the  $d$ -vicinal order which does not agree with the first  $(d - 1)$  orders. This happens if and only if there exist  $x$  and  $y$  such that  $x \succ_i y$  and  $y \succ_d x$  for some  $i \leq d - 1$ . Hence we have a  $(d - 2)$ -face  $w$  and a  $(d - 1)$ -face  $f$  such that  $xw, yf \in K$  and  $yw, xf \notin K$ . The total number of nodes in  $\{x, y, w, f\}$  is at least  $(d + 3)$  and at most  $(2d + 1)$ . Since  $n > (2d + 2)$ , there must exist a node  $a$ , not equal to  $x$  or  $y$  and not in  $f$  or  $w$ . Removing  $a$  from  $K$  cannot affect  $xw, yw, xf,$  or  $yf$ . This implies there cannot exist a shifted labeling on  $K \setminus a$ , which contradicts that  $K$  is an obstruction.

To finish the proof, we first note that if  $n < (d + 3)$ , then we cannot have any of the obstructing structures above. Next, we show a family of obstructions on  $(d + 3) \leq n \leq (2d + 2)$  nodes. For each of the following complexes, let the  $(d - 1)$ -skeleton be complete. Take two  $d$ -faces,  $(x, w_1, w_2, \dots, w_d)$  and  $(y, v_1, v_2, \dots, v_d)$ . Consider the amount of overlap between the  $v_i$ 's and the  $w_i$ 's. They may overlap on 0 to at most  $(d - 1)$  nodes. In each case, removing any node leaves at most one  $d$ -face on a complete  $(d - 1)$ -skeleton, which is shifted (see Fig. 8). □

One of the most important consequences of this theorem is that there are finitely many obstructions to shiftedness in each dimension. This means that we can check for shiftedness in a fixed dimension.

Obstructions to shifted families (shifted hypergraphs) were considered in [13] and extended by Duval and Shareshian [2]. They defined obstructions not with respect to an induced subgraph but to deletion and contraction. In this case it was shown that all obstructions are on  $n = 2d$  vertices.

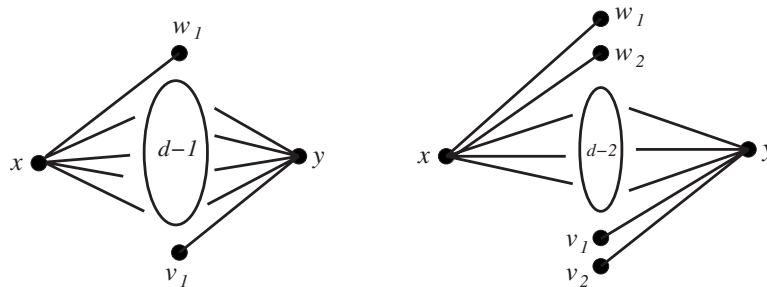

Fig. 8. A family of obstructions.

## 5. Enumeration

In one dimension the number of shifted complexes is the number of threshold graphs.

**Theorem.** *There are  $2^{n-1}$  non-isomorphic unlabeled threshold graphs on  $n$  nodes.*

*Proof.* Consider the constructive characterization of threshold graphs. Recall that all threshold graphs can be formed by successively performing two operations. This would give us  $2^n$  strings, except that, at the first step, starring a node and adding a disjoint node are equivalent. No two of these graphs are isomorphic to each other. One way to see this is to note that each string gives a unique degree sequence.  $\square$

Next we consider two-dimensional shifted complexes where the question of enumeration becomes much more difficult.

**Theorem 3.** *The number of two-dimensional shifted complexes on  $(n + 1)$  nodes is given by*

$$\prod_{1 \leq i \leq j \leq k \leq n} \frac{i + j + k - 1}{i + j + k - 2}.$$

The first few numbers of this series are

$$1, 2, 5, 16, 66, 352, 2431, \dots$$

This is a result of the connection between shifted complexes and totally symmetric plane partitions. We show that two-dimensional shifted complexes are in bijection with totally symmetric plane partitions.

**Definition 5.** A plane partition  $\pi = (\pi_{ij})_{i,j \geq 1}$  is an array of non-negative integers with non-increasing rows and columns. A plane partition is totally symmetric if  $\pi_{ij} = \pi_{ji}$  and each row, when considered as an ordinary partition, is self-conjugate (see Fig. 9).

Plane partitions can also be thought of as collections of blocks in  $\mathbb{R}^3$  where entry  $ij$  gives us the height of the blocks at that location. Then we can look at different symmetry classes of this structure. Totally symmetric plane partitions (TSPPs) correspond to plane partitions which are invariant under the action of  $S_3$ . In this setting, it is not hard to see that TSPPs are order ideals in the poset of Fig. 10, where a string  $(abc)$  represents all

3	3	2
3	2	1
2	1	0

**Fig. 9.** A totally symmetric plane partition.



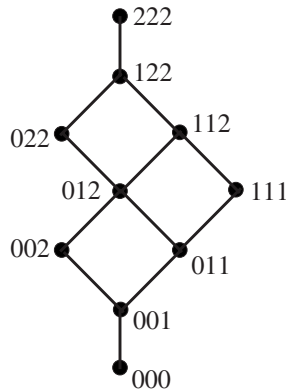

Fig. 10. TSPPs as order ideals.

permutations of the elements  $\{a, b, c\}$ . Given an order ideal  $\pi$  in  $\mathbb{N}^3$ , we recover the plane partition as follows:  $\pi_{ij} = |\{k : (i, j, k) \in \pi\}|$ . We can move between this poset and the shifted poset simply by adding (012) to each entry (see Fig. 11). Now it is clear that *two-dimensional shifted complexes are the same as TSPPs* as they are order ideals in the same poset. Theorem 3 is simply a restatement of the following:

**Theorem** [16]. *The number of TSPPs which fit in an  $(n \times n \times n)$  box is*

$$\prod_{1 \leq i \leq j \leq k \leq n} \frac{i + j + k - 1}{i + j + k - 2}.$$

These questions can be generalized by looking at stacks of cubes in higher dimensions which are invariant under certain symmetries. The  $d$ -dimensional shifted complexes exactly correspond to the  $d$ -dimensional analogue of a TSPP. Essentially nothing is known in this direction. There is not even a conjecture of the number of such structures for dimension four and higher. We refer the interested reader to [14]–[16] for much more on plane partitions and their enumeration.

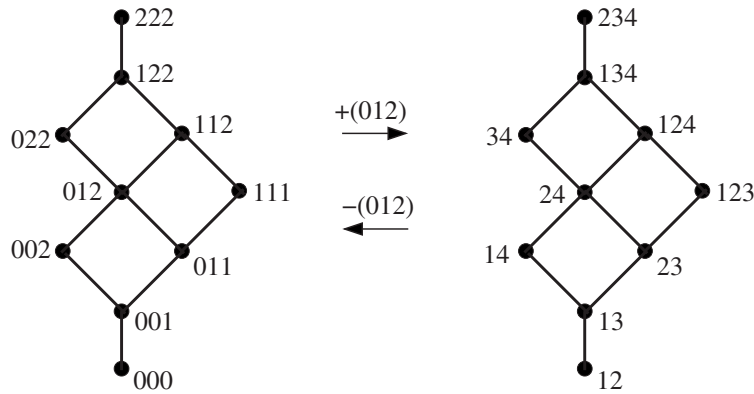

Fig. 11. Bijection between TSPPs and two-dimensional shifted complexes.

$n \backslash d$	Total	0	1	2	3	4	5
1	1	1					
2	2	1	1				
3	4	1	2	1			
4	9	1	4	3	1		
5	25	1	8	11	4	1	
6	99	1	16	50	26	5	1

Fig. 12. The number of pure shifted complexes in  $d$  dimensions on  $n$  nodes.

Next we give the first few entries in the number of pure shifted complexes (see Fig. 12). These numbers have many interesting properties. For example, let  $T_n$  be the total number of two-dimensional shifted complexes on  $n$  nodes. Then the number of pure two-dimensional shifted complexes on  $n$  nodes is  $T_{n-1} - T_{n-2}$ . Also, the second off diagonal consists of the Eulerian numbers  $2^k - k - 1$ , with  $k = n - 1$ . See [10] for a thorough discussion on the enumeration of pure shifted complexes.

Finally, we mention that although it is shown in the last section that there exists a finite number of obstructions in each dimension, the exact number is not known (even for  $d = 2$ ).

## References

1. A. Björner and G. Kalai, On  $f$ -vectors and homology, *Proc. NY Acad. Sci.*, **555** (1989), 63–80.
2. A. Duval and J. Shareshian, Personal communication.
3. P. Erdős, C. Ko, and R. Rado, Intersection theorems for systems of finite sets, *Quart. J. Math. Oxford Ser. 2*, **12** (1961), 313–320.
4. P. Frankl, The shifting technique in extremal set theory, in C. Whitehead (ed.), *Surveys in Combinatorics*, London Mathematical Society Lecture Notes Series, Vol. 123, Cambridge University Press, Cambridge, 1987, pp. 81–110.
5. M. C. Golumbic, *Algorithmic Graph Theory and Perfect Graphs*, Academic Press, New York, 1980.
6. G. Kalai, A characterization of  $f$ -vectors of families of convex sets in  $R^d$ , Part I: Necessity of Eckhoff's conditions, *Israel J. Math.*, **48** (1984), 175–195.
7. G. Kalai, A characterization of  $f$ -vectors of families of convex sets in  $R^d$ , Part II: Sufficiency of Eckhoff's conditions, *J. Combin. Theory Ser. A*, **41** (1986), 167–188.
8. G. Kalai, Algebraic shifting, in Takayuki Hibi (ed.), *Computational Commutative Algebra and Combinatorics*, Advanced Studies in Pure Mathematics, Vol. 33, Mathematical Society of Japan, Tokyo, 2002, pp. 121–163.
9. D. Kleitman, On a conjecture of Milner on  $k$ -graphs with non-disjoint edges, *J. Combin. Theory*, **5** (1968), 153–156.

10. C. Klivans, Combinatorial Properties of Shifted Complexes, Ph.D. Thesis, MIT, Cambridge, MA, 2003.
11. N.V.R. Mahadev and U.N. Peled, *Threshold Graphs and Related Topics*, Annals of Discrete Mathematics, Vol. 56, North-Holland, Amsterdam, 1995.
12. V. Reiner, Recent Progress in the Topology of Simplicial Complexes, AMS Regional Meeting, Williamstown, MA, 2001. <http://www.math.ethz.ch/feichtne/AMSmeeting/abstracts/reiner.html>.
13. J. Reiterman, V. Rödl, E. Sinajova, and M. Tuma, Threshold hypergraphs, *Discrete Math.*, **54** (1985), 193–200.
14. R. Stanley, A baker's dozen of conjectures concerning plane partitions, in G. Labelle and P. Leroux (eds.), *Combinatoire Enumerative*, Lecture Notes in Mathematics, No. 1234, Springer-Verlag, Berlin, 1986, pp. 285–293.
15. R. Stanley, *Enumerative Combinatorics 2*, Cambridge Studies in Advanced Mathematics, Vol. 62, Cambridge University Press, Cambridge, 1999.
16. J. Stembridge, The enumeration of totally symmetric plane partitions, *Adv. Math.*, **111** (1995), 227–243.
17. A. Taylor and W. Zwicker, *Simple Games*, Princeton University Press, Princeton, NJ, 1999.

*Received July 5, 2003, and in revised form February 13, 2004. Online publication June 4, 2004.*