

The initial drift of a 2D droplet at zero temperature

Raphaël Cerf · Sana Louhichi

Received: 24 November 2004 / Revised: 16 March 2006 /
Published online: 21 June 2006
© Springer-Verlag 2006

Abstract We consider the 2D stochastic Ising model evolving according to the Glauber dynamics at zero temperature. We compute the initial drift for droplets which are suitable approximations of smooth domains. A specific spatial average of the derivative at time 0 of the volume variation of a droplet close to a boundary point is equal to its curvature multiplied by a direction dependent coefficient. We compute the explicit value of this coefficient.

Keywords 2D Ising model · Glauber dynamics · Zero temperature · Markov process · Mean curvature · Velocity

Mathematics Subject Classification (2000) 60K35 · 82C22

1 Introduction

The phenomenological theory asserts that the evolution of the shape of a droplet of one phase immersed in another phase is governed by the motion by mean curvature. We are still far from being able to verify this assertion starting from a genuine microscopic dynamics. Very interesting results have been obtained in a series of works in the context of the Ising model with Kac potentials [4–7]. However, motion by mean curvature is recovered in some scaling limit where the range of the interactions diverges to infinity: the model becomes somehow close to a mean-field model and the ensuing motion is isotropic. For the true Ising model with only nearest-neighbour interactions, it is expected that an interface between the minus and the plus phase evolves according to an anisotropic

R. Cerf · S. Louhichi (✉)
Université de Paris-Sud, Probabilités, statistique et modélisation,
Bât. 425, 91405 Orsay Cedex, France
e-mail: sana.louhichi@math.u-psud.fr

R. Cerf
e-mail: rcerf@math.u-psud.fr

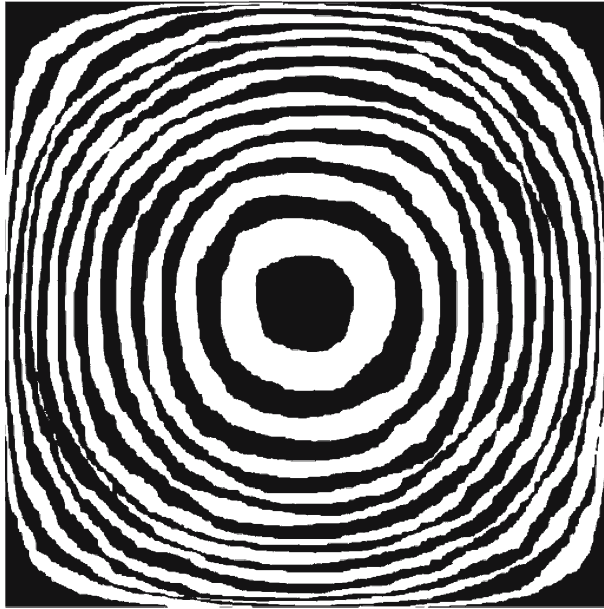

Evolution of a square droplet

motion by mean curvature, that is, each point x of the interface has velocity

$$v(x) = -c(v(x))\xi v(x),$$

where $v(x)$ is the vector normal to the interface at x , ξ is the curvature of the interface at x and $c(v)$ is a coefficient depending on the direction of v . This anisotropy stems from the anisotropy of the cubic lattice.

In this paper, we consider the zero temperature Glauber dynamics for the 2D Ising model. Although we do not succeed in deriving the full motion by mean curvature, we manage to compute the initial drift for droplets which approximate suitably smooth domains and we believe this is a crucial step. Four works are directly relevant. Spohn [10] establishes the mean curvature motion in the context of the 2D Ising model at zero temperature for interfaces which can be represented as the graph of a function (but the fine details of his argument are not written out). Although his results do not apply directly to the case of a full droplet, he succeeds in particular in deriving an explicit formula for the coefficient $c(v)$. We recover the same formula here with a different approach. The computation we present here can be considered to be a refinement of the observation of [3]. Chayes et al. [3] proved a Lifshitz law for the volume of a two-dimensional droplet at zero temperature (for a technical reason, they work with a slightly modified dynamics). Instead of looking at the total volume of the droplet, we shall concentrate here on the volume variation of the droplet in a small ball attached to its boundary. Chayes and Swindle [2] study the hydrodynamical limit of the zero range process (we do not understand fully their proof); by interpreting the interface as a one dimensional exclusion process, they conclude that the evolution of the shape of one corner of a square droplet should

be described in the hydrodynamical limit by an appropriate Stefan problem. Finally, Sowers [9] develops in a framework of geometric measure theory to obtain the hydrodynamical limit. His convergence theorem is conditional on the verification of several assumptions, some of them concerning the structure of the interface. It might be that these estimates are the missing pieces to complete the picture.

Let us turn now to the description of our result. We work with the stochastic Ising model evolving according to the Glauber dynamics at zero temperature. We consider the diffusive limit where space is rescaled by a factor N and time is speeded up by a factor N^2 . We start with a plus droplet immersed in the minus phase, whose boundary is a C_1 simple Jordan curve γ : the initial configuration at step N is a suitable approximation of the smooth droplet, drawn on the square lattice \mathbb{Z}^2/N . We consider two cases:

Deterministic initial condition The approximating set at step N consists of the squares of the lattice \mathbb{Z}^2/N which intersect the interior of γ .

Initial local equilibrium The approximating set at step N is random. Its boundary converges in probability towards γ as N goes to ∞ and its law μ_N is given by the invariant measure of the associated zero range process.

The droplet is immersed in the minus phase, hence all the sites of the approximating set are initially set to plus, while the other sites of the lattice are set to minus. We then look at the process $(\sigma_{N^2t}, t \geq 0)$ and we denote by $\mathcal{A}_\sigma^N(t)$ the plus droplet at time N^2t starting from σ . Let x be a point of γ . We study the variation of the magnetization inside the ball $B(x, r)$ centered at x with radius r , for r small. Equivalently, we look at the volume $\text{vol}(B(x, r) \cap \mathcal{A}_\sigma^N(t))$ of the plus droplet in this ball and we aim at computing its derivative

$$\lim_{t \rightarrow 0} \frac{1}{t} \left(\text{vol}(B(x, r) \cap \mathcal{A}_\sigma^N(t)) - \text{vol}(B(x, r) \cap \mathcal{A}_\sigma^N(0)) \right).$$

Several problems arise. Since the dynamics proceeds by jumps, we have to take the expectation to get a differentiable quantity. Next we wish to link the infinitesimal volume variation with the curvature of the droplet's boundary at x . To achieve this, we need to recover the slope of the continuous curve from its approximation. We perform a spatial averaging. Letting x_0, x_1 be the two points of γ which belong to the sphere $\partial B(x, r)$, we consider the domain

$$S(x, r, \alpha_1, \alpha_2) = B(x, r) \cup B(x_0, \alpha_1) \cup B(x_1, \alpha_2),$$

and we denote by \mathcal{S}_N its discretization at step N . The quantity of primary interest to link the volume variation and the curvature is

$$\begin{aligned} \mathbf{A}_N^{\sigma, \gamma}(x, r, \delta) = \\ \frac{1}{\delta^2} \int_0^\delta \int_0^\delta \lim_{t \rightarrow 0} \frac{1}{t} \mathbb{E} \left((\text{vol}(\mathcal{A}_\sigma^N(t) \cap \mathcal{S}_N) - \text{vol}(\mathcal{A}_\sigma^N(0) \cap \mathcal{S}_N)) \right) d\alpha_1 d\alpha_2. \end{aligned}$$

Let θ be the angle of the tangent to γ at x and let $\xi_\gamma(x)$ be the curvature of γ at x . Our main result states that, for the deterministic initial condition,

$$\begin{aligned} \lim_{r \rightarrow 0} \lim_{\delta \rightarrow 0} \liminf_{N \rightarrow \infty} \frac{1}{2r} \mathbf{A}_N^{\sigma, \gamma}(x, r, \delta) &= \lim_{r \rightarrow 0} \lim_{\delta \rightarrow 0} \limsup_{N \rightarrow \infty} \frac{1}{2r} \mathbf{A}_N^{\sigma, \gamma}(x, r, \delta) \\ &= -\frac{1}{2} |\cos(2\theta)| \xi_\gamma(x) \end{aligned}$$

while with the initial local equilibrium,

$$\begin{aligned} \lim_{r \rightarrow 0} \lim_{\delta \rightarrow 0} \liminf_{N \rightarrow \infty} \frac{1}{2r} \mu_N(\mathbf{A}_N^{\sigma, \gamma}(x, r, \delta)) &= \lim_{r \rightarrow 0} \lim_{\delta \rightarrow 0} \limsup_{N \rightarrow \infty} \frac{1}{2r} \mu_N(\mathbf{A}_N^{\sigma, \gamma}(x, r, \delta)) \\ &= -\frac{\xi_\gamma(x)}{2(|\cos \theta| + |\sin \theta|)^2}. \end{aligned}$$

In fact, we compute the above limits for a more general class of initial conditions, which includes the two cases above. The natural case should be the one studied by Spohn, where the configuration is locally in equilibrium. We expect that, starting from any initial configuration, the law of a straight interface will converge quickly to the equilibrium law of the associated zero range process. This indicates that the limit $(\mathcal{A}(t), t \geq 0)$ of any decently converging subsequence of the stochastic motion $(\mathcal{A}^N(t), t \geq 0)$ should satisfy the equation, for any $s > 0$ and for any $x \in \partial\mathcal{A}(s)$,

$$\begin{aligned} \lim_{r \rightarrow 0} \lim_{\delta \rightarrow 0} \frac{1}{2r\delta^2} \int_0^\delta \int_0^\delta \lim_{\substack{t \rightarrow s \\ t > s}} \frac{1}{t-s} \mathbb{E}(\text{vol}(\mathcal{A}(t) \cap \mathcal{S}) - \text{vol}(\mathcal{A}(s) \cap \mathcal{S})) \, d\alpha_1 \, d\alpha_2 \\ = -\frac{\xi_{\partial\mathcal{A}(s)}(x)}{2(|\cos \theta| + |\sin \theta|)^2} \end{aligned}$$

or at least a weaker variant of it. Here $(\mathcal{A}(t), t \geq 0)$ is a random process describing the evolution of the shape of the droplet. A standard computation shows that the deterministic motion by mean curvature satisfies this equation. However we do not know whether it is the only solution to this equation; we have not investigated the corresponding theory so far. For instance, can one get rid of the expectation? Anyway, we are still far from establishing that the hydrodynamical limit of the droplet process satisfies the above equation. An important issue is to control dynamically the proportion of the corners in a microscopic random interface when its average slope is known. This would probably require some additional probabilistic input.

2 The model

We consider a zero-temperature 2D-stochastic Ising model. More precisely it is a continuous time Markov process $(\sigma_t)_{t \geq 0}$ taking values in $\{-1, +1\}^{\mathbb{Z}^2}$ with generator L which acts on each local function $f : \{-1, +1\}^{\mathbb{Z}^2} \rightarrow \mathbb{R}$ as

$$(Lf)(\sigma) = \sum_{x \in \mathbb{Z}^2} c(x, \sigma)(f(\sigma^x) - f(\sigma)).$$

Here, for $\sigma \in \{-1, +1\}^{\mathbb{Z}^2}$ and $x \in \mathbb{Z}^2$, we define

$$\forall y \in \mathbb{Z}^2 \quad \sigma^x(y) = \begin{cases} \sigma(y) & \text{if } y \neq x, \\ -\sigma(y) & \text{if } y = x, \end{cases}$$

and $c(x, \sigma)$ is the rate with which the spin at site x flips when the configuration is σ . The rates $c(x, \sigma)$ define the dynamics. For the zero-temperature 2D-Ising model, the rates $c(x, \sigma)$ are given by

$$c(x, \sigma) = \begin{cases} 1 & \text{if more than two neighbors of } x \text{ have a spin opposite to } x, \\ \alpha & \text{if exactly two neighbors of } x \text{ have a spin opposite to } x, \\ 0 & \text{otherwise,} \end{cases}$$

where $0 < \alpha \leq 1$ is a fixed parameter. For technical reasons, we will take $\alpha = 1/2$ in the sequel.

3 Notation

Let N be a fixed positive integer. We denote by \mathbb{Z}_N^2 the grid \mathbb{Z}^2/N . For $x = (x_1, x_2) \in \mathbb{Z}^2$, $\Lambda_{x/N}$ is the box defined as

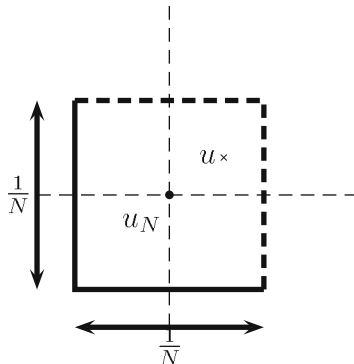

A point u and the box Λ_{u_N} ($Nu_N \in \mathbb{Z}^2$)

$$\Lambda_{x/N} = \left\{ (u_1, u_2) \in \mathbb{R}^2, \quad -\frac{1}{2N} \leq u_1 - \frac{x_1}{N} < \frac{1}{2N}; \right. \\ \left. -\frac{1}{2N} \leq u_2 - \frac{x_2}{N} < \frac{1}{2N} \right\}. \tag{1}$$

The family of boxes $(\Lambda_x, x \in \mathbb{Z}_N^2)$, as defined by (1), forms a partition of \mathbb{R}^2 :

$$\mathbb{R}^2 = \bigcup_{x \in \mathbb{Z}_N^2} \Lambda_x, \quad \forall x, y \in \mathbb{Z}_N^2 \quad x \neq y \Rightarrow \Lambda_x \cap \Lambda_y = \emptyset.$$

Hence, for each $u = (u_1, u_2) \in \mathbb{R}^2$ there exists a unique $u_N \in \mathbb{Z}_N^2$ such that $u \in \Lambda_{u_N}$. Moreover $\|u - u_N\|_\infty \leq \frac{1}{2N}$, where $\|u\|_\infty = \max(|u_1|, |u_2|)$.

To each bounded set S of \mathbb{R}^2 , we associate the set S_N defined by

$$S_N = \bigcup_{x \in \mathbb{Z}_N^2: \Lambda_x \cap S \neq \emptyset} \Lambda_x.$$

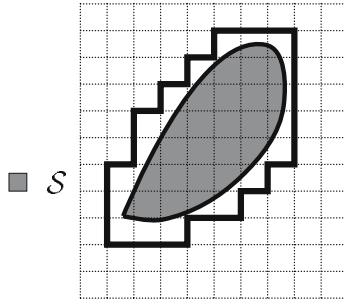

The set S is included in the set S_N with polygonal boundary

For $\sigma \in \{-1, +1\}$, we denote by $s(\sigma, x)$, the number of the neighbors of x having a spin opposite to x in the configuration σ :

$$s(\sigma, x) = \frac{1}{2} \sum_{y \in \mathbb{Z}^2, |x-y|=1} |\sigma(x) - \sigma(y)|,$$

where $|x| = \sqrt{x_1^2 + x_2^2}$ for $x = (x_1, x_2)$.

Let N be a fixed positive integer, we define the set

$$\mathcal{A}_N^\sigma = \bigcup_{x \in \mathbb{Z}^2, \sigma(x)=+1} \Lambda_{x/N}.$$

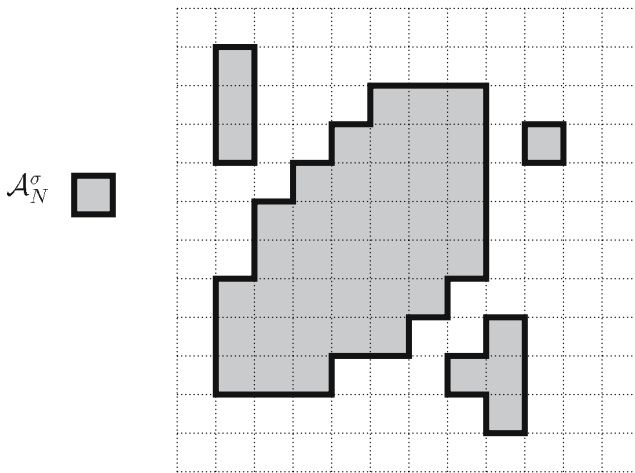

For $x \in \mathbb{Z}^2$, $\sigma(x) = +1$ if and only if $x \in N\mathcal{A}_N^\sigma$

Let γ be a curve of \mathbb{R}^2 . We define for $s \in \gamma$ and for r, α_1, α_2 positive real numbers, the set

$$S(s, r, \alpha_1, \alpha_2) = B(s, r) \cup B(x_0, \alpha_1) \cup B(x_1, \alpha_2),$$

where $B(s, r)$ is the closed ball centered at s with radius r chosen sufficiently small, so that $\partial B(s, r) \cap \gamma$ contains exactly two points x_0 and x_1 . We suppose that x_0, s and x_1 are arranged counterclockwise.

Let

$$L_N^{\sigma, \gamma}(s, r, \alpha_1, \alpha_2) = \lim_{t \rightarrow 0} \frac{1}{t} \left(\mathbb{E}_\sigma(\text{vol}(\mathcal{A}_N^{\sigma t N^2} \cap \mathcal{S}_N)) - \text{vol}(\mathcal{A}_N^\sigma \cap \mathcal{S}_N) \right),$$

where $\mathcal{S}_N = (S(s, r, \alpha_1, \alpha_2))_N = (B(s, r) \cup B(x_0, \alpha_1) \cup B(x_1, \alpha_2))_N$ and vol denotes the planar Lebesgue measure.

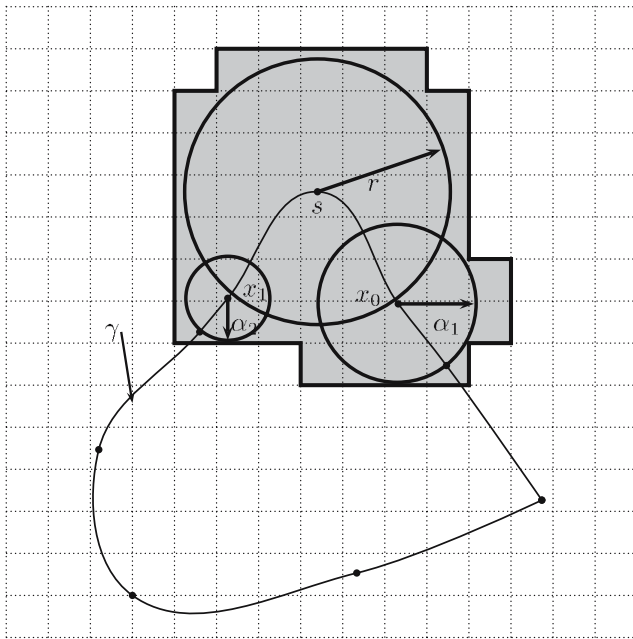

The set $(B(s, r) \cup B(x_0, \alpha_1) \cup B(x_1, \alpha_2))_N$

Finally, we define the average

$$\mathbf{A}_N^{\sigma, \gamma}(s, r, \delta) = \frac{1}{\delta^2} \int_0^\delta \int_0^\delta L_N^{\sigma, \gamma}(s, r, \alpha_1, \alpha_2) \, d\alpha_1 \, d\alpha_2.$$

4 Results

We first control the quantity $\mathbf{A}_N^{\sigma,\gamma}(s, r, \delta)$ for deterministic sets \mathcal{A}_N^σ defined as follows.

Deterministic initial condition Let γ be a Jordan curve of \mathbb{R}^2 . Suppose that γ encloses a connected, compact and bounded set Ω of \mathbb{R}^2 , so that $\gamma = \partial\Omega$. Let N be a fixed positive integer. We define the spin configuration σ at time 0 as:

$$\forall x \in \mathbb{Z}^2 \quad \sigma(x) = \begin{cases} +1 & \text{if } \Lambda_{x/N} \cap \Omega \neq \emptyset, \\ -1 & \text{otherwise,} \end{cases}$$

where, for $x \in \mathbb{Z}^2$ and $N \in \mathbb{N}^*$, $\Lambda_{x/N}$ is the box as defined by (1). We will say that σ is the spin configuration associated to the curve γ at step N .

Having both the initial condition and the generator, the Markov process $(\sigma_t)_{t \geq 0}$ at step N is well defined.

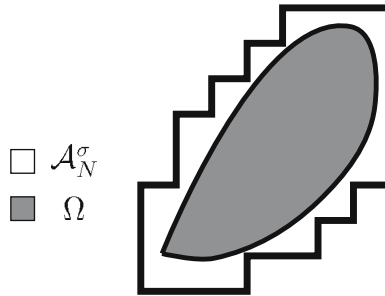

The curve $\gamma = \partial\Omega$ and the set \mathcal{A}_N^σ

Proposition 1 Let γ be a Jordan curve of \mathbb{R}^2 of class C_2 . Suppose that γ encloses a connected, compact and bounded set Ω of \mathbb{R}^2 . Let s be a point of γ . Let σ be the spin configuration associated to the curve γ at step N . Then,

$$\begin{aligned} \lim_{r \rightarrow 0} \lim_{\delta \rightarrow 0} \liminf_{N \rightarrow +\infty} \frac{1}{2r} \mathbf{A}_N^{\sigma,\gamma}(s, r, \delta) &= \lim_{r \rightarrow 0} \lim_{\delta \rightarrow 0} \limsup_{N \rightarrow +\infty} \frac{1}{2r} \mathbf{A}_N^{\sigma,\gamma}(s, r, \delta) \\ &= -\frac{1}{2} |\cos 2\theta| \xi_\gamma(s), \end{aligned}$$

where $\xi_\gamma(s)$ is the curvature of γ at s and θ is the angle between the horizontal axis and the tangent to the curve γ at s .

We suppose next that the sets \mathcal{A}_N^σ are random and that locally the height function associated to $\partial\mathcal{A}_N^\sigma$ obeys to Spohn's initial condition described as follows.

Initial local equilibrium Let γ be a Jordan curve of \mathbb{R}^2 . Suppose that γ encloses a connected, compact and bounded set Ω of \mathbb{R}^2 , so that $\gamma = \partial\Omega$. Let s be

a point of γ . Suppose that, on a neighborhood V_s of s , the contour γ is the graph of a monotone differentiable function f defined on a segment $[a, b]$. For each positive integer N , and for each random boundary $\partial\mathcal{A}_N^\sigma \cap V_s$, let Φ_N be the random height function associated to $\partial\mathcal{A}_N^\sigma \cap V_s$ above $\frac{\mathbb{Z}}{N} \cap [a, b]$, defined by

$$\forall u \in \frac{\mathbb{Z}}{N} \cap [a, b] \quad \Phi_N(u) = \sup\{v : (u, v) \in \partial\mathcal{A}_N^\sigma\}.$$

Let μ_N be the initial distribution of Φ_N . We suppose that, under μ_N , the increments

$$\Phi_N\left(\frac{k+1}{N}\right) - \Phi_N\left(\frac{k}{N}\right), \quad \frac{k}{N} \in [a, b] \cap \frac{\mathbb{Z}}{N},$$

are independent and their laws are such that

- If f is nondecreasing, then for $l \in \mathbb{Z}$

$$\begin{aligned} \mu_N \left(\Phi_N\left(\frac{k+1}{N}\right) - \Phi_N\left(\frac{k}{N}\right) = \frac{l}{N} \right) \\ = \begin{cases} (f'(\frac{k}{N}))^l (1 + f'(\frac{k}{N}))^{-l-1} & \text{if } l \geq 0 \\ 0 & \text{if } l < 0 \end{cases} \end{aligned}$$

- If f is nonincreasing, then for $l \in \mathbb{Z}$

$$\begin{aligned} \mu_N \left(\Phi_N\left(\frac{k+1}{N}\right) - \Phi_N\left(\frac{k}{N}\right) = \frac{l}{N} \right) \\ = \begin{cases} (|f'|(\frac{k}{N}))^{|l|} (1 + |f'|(\frac{k}{N}))^{-|l|-1} & \text{if } l \leq 0 \\ 0 & \text{if } l > 0 \end{cases} \end{aligned}$$

Proposition 2 *Let γ be a Jordan curve of \mathbb{R}^2 of class C_2 . Let s be a point of γ . Suppose that, for any positive real numbers r and δ sufficiently small, the curve $\gamma \cap S(s, r, \delta, \delta)$ is the graph of a monotone function f defined on a segment $[a, b]$ of \mathbb{R} . Let μ_N be the measure as defined above. Suppose that,*

$$\forall \varepsilon > 0 \quad \lim_{N \rightarrow +\infty} \mu_N (|\Phi_N(a_N) - f(a)| \geq \varepsilon) = 0, \tag{2}$$

where a_N is a point of $[a, b] \cap \frac{\mathbb{Z}}{N}$ such that $|a - a_N| \leq \frac{1}{N}$. Then

$$\begin{aligned} \lim_{r \rightarrow 0} \lim_{\delta \rightarrow 0} \liminf_{N \rightarrow +\infty} \frac{1}{2r} \mu_N(\mathbf{A}_N^{\sigma, \gamma}(s, r, \delta)) &= \lim_{r \rightarrow 0} \lim_{\delta \rightarrow 0} \limsup_{N \rightarrow +\infty} \frac{1}{2r} \mu_N(\mathbf{A}_N^{\sigma, \gamma}(s, r, \delta)) \\ &= -\frac{1}{2(|\cos \theta| + |\sin \theta|)^2} \xi_\gamma(s), \end{aligned}$$

where $\xi_\gamma(s)$ is the curvature of γ at s and θ is the angle between the horizontal axis and the tangent to the curve γ at s .

The limits obtained in Propositions 1 and 2 are very different because the initial conditions differ. Spohn’s velocity is recovered in Proposition 2 [cf. (4.26) of Spohn [10]]. The choice of the measure μ_N is the good one, since as noticed by Spohn [10], the height differences are governed by the zero-range process with rate function $c(n) = \mathbb{I}_{n \geq 1}$. The product measure μ_N with geometric distribution is invariant for the zero range process (cf. [1]). Motion by mean curvature for the sets $(\mathcal{A}_N^{\sigma, 2r})$ corresponds then to the hydrodynamic limit for the zero range process.

Propositions 1 and 2 are consequences of the following Theorem 2, which handles the initial conditions described thereafter. The distance between a point $a \in \mathbb{R}^2$ and a subset B of \mathbb{R}^2 is $d(a, B) = \inf_{b \in B} |a - b|$; the Hausdorff distance d_H between two subsets A and B of \mathbb{R}^2 is

$$d_H(A, B) = \max \left(\sup_{a \in A} d(a, B), \sup_{b \in B} d(b, A) \right).$$

Initial condition Let γ be a Jordan curve of \mathbb{R}^2 of class \mathcal{C}_1 . Suppose that γ encloses a connected, compact and bounded set Ω of \mathbb{R}^2 . Let s be a point of γ . Let r be a positive real number sufficiently small such that $\partial B(s, r) \cap \gamma$ contains exactly two points x_0 and x_1 . Suppose that x_0, s and x_1 are arranged counterclockwise. Let $\theta_1 \in [0, 2\pi]$ (respectively $\theta_0 \in [0, 2\pi]$) be the oriented angle between the half horizontal axis $[0, +\infty[$ and $T_{x_1}\gamma$ (respectively $T_{x_0}\gamma$). We suppose that there exists a neighborhood V_s of s and a probability measure ν_N such that

$$\forall \varepsilon > 0 \quad \lim_{N \rightarrow +\infty} \nu_N \left(d_H(\mathcal{A}_N^\sigma \cap V_s, \Omega \cap V_s) \geq \varepsilon \right) = 0, \tag{3}$$

and that, with probability one, the boundaries γ and $\partial \mathcal{A}_N^\sigma$ are, in V_s , either both non-increasing or either both non-decreasing.

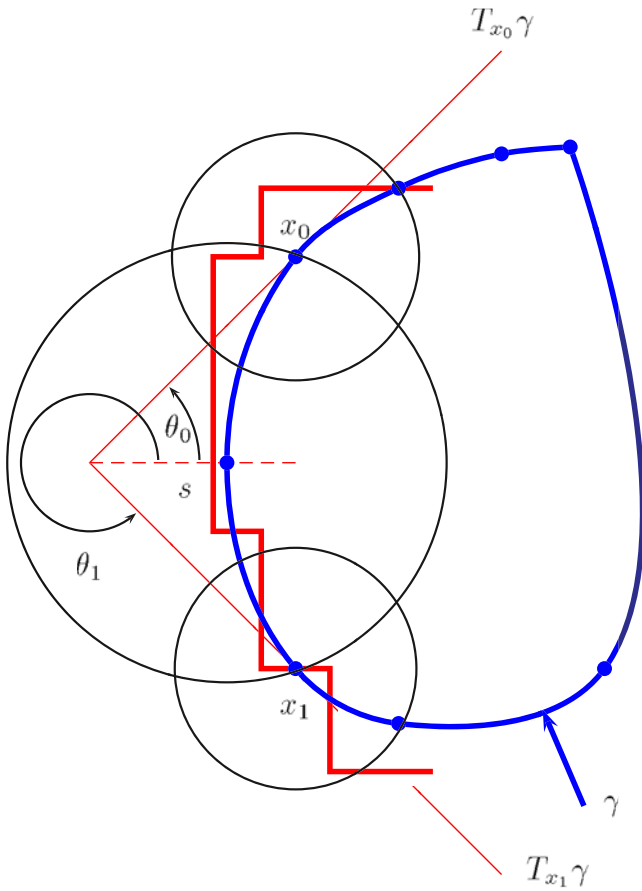

The polygonal curve ∂A_N^σ behaves in V_s as γ

Let, for $x \in \gamma \cap V_s$ and $\delta > 0$,

$$C_N(x, \delta) = \sum \mathbb{I}_{\sigma(y)=+1, s(\sigma,y)=2},$$

where the sum is taken over all $y \in \mathbb{Z}^2$ for which $\frac{y}{N}$ is a point of $(B(x, \delta))_N \setminus B(s, |x - s|)$. The quantity $C_N(x, \delta)$ is equal to half of the number of the corners of the polygonal line ∂A_N^σ belonging to $(B(x, \delta))_N \setminus B(s, |x - s|)$.

We first suppose that γ is a polygon and that s is a corner point of γ . In this case, the following theorem proves that, for r and δ sufficiently small, the limit as N goes to infinity of $\nu_N(\mathbf{A}_N^{\sigma,\gamma}(s, r, \delta))$ exists under a suitable behavior of the expected proportions of corners $\frac{1}{N} \nu_N(C_N(x_k, \delta))$, for $k \in \{0, 1\}$.

Theorem 1 *Let γ, s, r, δ and ν_N be as described in the previous initial condition. Suppose that γ is a polygon and that for $k = 0, 1$ and for r, δ sufficiently small,*

the following limit holds:

$$\lim_{N \rightarrow \infty} \frac{1}{N} \nu_N(C_N(x_k, \delta)) = \delta C(\theta_k). \tag{4}$$

Then, for r and δ sufficiently small, one has

$$\begin{aligned} \lim_{N \rightarrow \infty} \nu_N(\mathbf{A}_N^{\sigma, \gamma}(s, r, \delta)) &= -\frac{1}{2} \operatorname{sgn}(\tan \theta_0) \left(\cos^2 \theta_0 + C(\theta_0) (|\sin \theta_0| - |\cos \theta_0|) \right) \\ &+ \frac{1}{2} \operatorname{sgn}(\tan \theta_1) \left(\cos^2 \theta_1 + C(\theta_1) (|\sin \theta_1| - |\cos \theta_1|) \right) \\ &+ \mathbb{I}_{\sin \theta_0 \sin \theta_1 > 0} \left(\operatorname{sgn}(\theta_1 - \theta_0) \mathbb{I}_{\cos \theta_0 \cos \theta_1 > 0} + \operatorname{sgn}(\tan \theta_0) \mathbb{I}_{\cos \theta_0 \cos \theta_1 < 0} \right). \end{aligned} \tag{5}$$

Suppose that $C(\theta) = f(|\sin \theta|, |\cos \theta|)$, where f is a positive function defined on $[0, 1] \times [0, 1]$ and that s is not a corner point of the polygon γ . Theorem 1 then implies that, for r and δ sufficiently small, the limit as N goes to infinity of $\nu_N(\mathbf{A}_N^{\sigma, \gamma}(s, r, \delta))$ vanishes (since in this case $\theta_1 = \theta_0 \pm \pi$). This constatation is not surprising since the inverse of the curvature of a straight line vanishes.

The following theorem extends Theorem 1 to Jordan curves.

Theorem 2 *Let γ, s, r and ν_N be as described in the previous initial condition. Suppose that for r sufficiently small and for $k = 0, 1$, the following limits exist:*

$$\lim_{\delta \rightarrow 0} \liminf_{N \rightarrow +\infty} \frac{1}{\delta N} \nu_N(C_N(x_k, \delta)) = \lim_{\delta \rightarrow 0} \limsup_{N \rightarrow +\infty} \frac{1}{\delta N} \nu_N(C_N(x_k, \delta)) = C(\theta_k). \tag{6}$$

Then

$$\lim_{\delta \rightarrow 0} \liminf_{N \rightarrow +\infty} \nu_N(\mathbf{A}_N^{\sigma, \gamma}(s, r, \delta)) = \lim_{\delta \rightarrow 0} \limsup_{N \rightarrow +\infty} \nu_N(\mathbf{A}_N^{\sigma, \gamma}(s, r, \delta)),$$

the common value is as in (5) with the function $C(\cdot)$ given by (6).

5 Proofs

We first prove Theorems 1 and 2. Next, we prove the two propositions. For the proof of the theorems, we need the following preliminary lemma.

Lemma 1 *Let S be a compact set of \mathbb{R}^2 . Let $\sigma \in \{-1, +1\}^{\mathbb{Z}^2}$ be fixed. Then*

$$\begin{aligned} & \lim_{t \rightarrow 0} \frac{1}{t} \left(\mathbb{E}_\sigma (\text{vol}(\mathcal{A}_N^{\sigma, tN^2} \cap \mathcal{S}_N)) - \text{vol}(\mathcal{A}_N^\sigma \cap \mathcal{S}_N) \right) \\ &= \sum_{x \in \mathbb{Z}^2: \Lambda_{\frac{x}{N}} \subset \mathcal{S}_N} \left(\mathbb{I}_{\sigma(x)=-1, s(\sigma, x) \geq 3} - \mathbb{I}_{\sigma(x)=+1, s(\sigma, x) \geq 3} \right) \\ & \quad + \alpha \sum_{x \in \mathbb{Z}^2: \Lambda_{\frac{x}{N}} \subset \mathcal{S}_N} \left(\mathbb{I}_{\sigma(x)=-1, s(\sigma, x)=2} - \mathbb{I}_{\sigma(x)=+1, s(\sigma, x)=2} \right). \end{aligned}$$

Proof of Lemma 1 Let $f_N(\sigma) = \text{vol}(\mathcal{A}_N^\sigma \cap \mathcal{S}_N)$ and $S(t)f_N(\sigma) = \mathbb{E}_\sigma (\text{vol}(\mathcal{A}_N^{\sigma_t} \cap \mathcal{S}_N))$. We deduce from

$$\lim_{t \rightarrow 0} \frac{1}{t} (S(t)f_N - f_N) = Lf_N,$$

that

$$\lim_{t \rightarrow 0} \frac{1}{t} (S(t)f_N(\sigma) - f_N(\sigma)) = \sum_{x \in \mathbb{Z}^2} c(x, \sigma) (f_N(\sigma^x) - f_N(\sigma)). \tag{7}$$

Now,

$$f_N(\sigma^x) - f_N(\sigma) = \frac{1}{N^2} \mathbb{I}_{\Lambda_{\frac{x}{N}} \subset \mathcal{S}_N} (\mathbb{I}_{\sigma(x)=-1} - \mathbb{I}_{\sigma(x)=1}),$$

this fact together with (7) gives

$$\lim_{t \rightarrow 0} \frac{1}{t} (S(tN^2)f_N(\sigma) - f_N(\sigma)) = \sum_{x \in \mathbb{Z}^2: \Lambda_{\frac{x}{N}} \subset \mathcal{S}_N} c(x, \sigma) (\mathbb{I}_{\sigma(x)=-1} - \mathbb{I}_{\sigma(x)=1}),$$

which proves Lemma 1 since $c(x, \sigma) = \mathbb{I}_{s(\sigma, x) \geq 3} + \alpha \mathbb{I}_{s(\sigma, x)=2}$. □

5.1 Evaluation of $v_N (L_N^{\sigma, \gamma} (s, r, \alpha_1, \alpha_2))$

Throughout this step, we consider the set

$$\mathcal{S}_N = (\mathcal{S}(s, r, \alpha_1, \alpha_2))_N = (B(s, r) \cup B(x_0, \alpha_1) \cup B(x_1, \alpha_2))_N, \tag{8}$$

where α_1, α_2 are positive real numbers less than δ , the positive real numbers r and δ are small enough so that $\partial B(s, r) \cap \gamma$ contains exactly two points x_0 and x_1 .

The boundary of \mathcal{A}_N^σ which is included in \mathcal{S}_N can be described as a sequence v_1, \dots, v_r of horizontal or vertical vectors of norm $\frac{1}{N}$, enumerated counterclockwise. We denote by $e_N^1(\alpha_1), e_N^2(\alpha_2)$ the two unit vectors defined by

$$e_N^1(\alpha_1) = Nv_1, \quad e_N^2(\alpha_2) = Nv_r, \tag{9}$$

and by \mathcal{L}_N^σ the maximal subgraph of $\partial \mathcal{A}_N^\sigma$ included in \mathcal{S}_N :

$$\mathcal{L}_N^\sigma = (v_1, \dots, v_r). \tag{10}$$

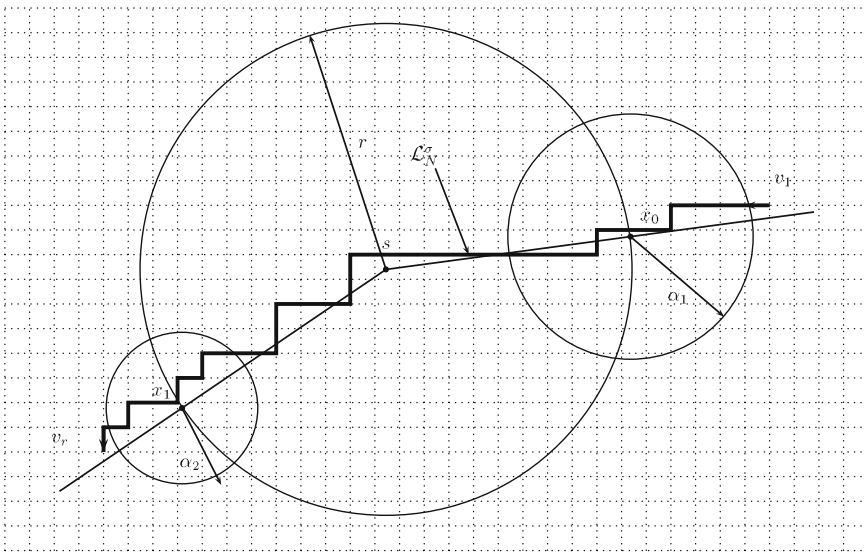

The polygonal line $\mathcal{L}_N^\sigma = (v_1, \dots, v_r)$. Here $\mathcal{S}_N = (B(s, r) \cup B(x_0, \alpha_1) \cup B(x_1, \alpha_2))_N$

We now need the following definition and notation.

Definition 1 We say that \mathcal{L}_N is a path on \mathbb{Z}_N^2 if \mathcal{L}_N is a finite sequence of consecutive vectors $(v_i)_{1 \leq i \leq r}$ (this means that the endpoint of v_i is the starting point of v_{i+1} for $1 \leq i < r$) of norm $1/N$, drawn on the grid \mathbb{Z}_N^2 , and such that the endpoints of these vectors (resp. the starting points) are distinct.

The following family of vectors (v_1, \dots, v_r) is a path on the grid \mathbb{Z}_N^2

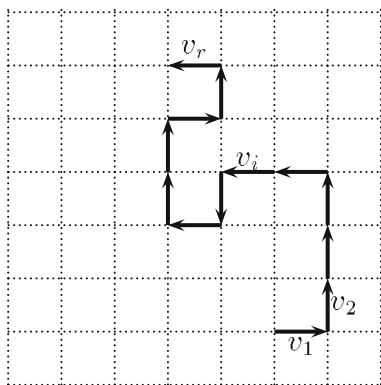

Notation Let $\mathcal{L}_N = (v_1, v_2, \dots, v_r)$ be a path on \mathbb{Z}^2_N . We define

$$\begin{aligned}
 N_+(\mathcal{L}_N) &= \text{card} \left\{ i : \widehat{(v_i, v_{i+1})} = -\frac{\pi}{2} \right\}, \\
 N_-(\mathcal{L}_N) &= \text{card} \left\{ i : \widehat{(v_i, v_{i+1})} = +\frac{\pi}{2} \right\},
 \end{aligned}
 \tag{11}$$

where $\widehat{(v_i, v_{i+1})}$ denotes the oriented angle between v_i and v_{i+1} .

The purpose of the following proposition is to establish the relation between $N_-(\mathcal{L}_N^\sigma) - N_+(\mathcal{L}_N^\sigma)$ and $L_N^{\sigma, \gamma}(s, r, \alpha_1, \alpha_2)$, for the path \mathcal{L}_N^σ as defined by (10).

Proposition 3 *Let N be a fixed positive integer. Let \mathcal{L}_N^σ be the random path as defined by (10). Then*

$$\nu_N(L_N^{\sigma, \gamma}(s, r, \alpha_1, \alpha_2)) = \frac{1}{2} \nu_N(N_-(\mathcal{L}_N^\sigma) - N_+(\mathcal{L}_N^\sigma)).
 \tag{12}$$

Proof of Proposition 3 Let $N \in \mathbb{N}^*$ be fixed and $\mathcal{S}_N = (B(s, r) \cup B(x_0, \alpha_1) \cup B(x_1, \alpha_2))_N$. Let f be the function defined from $\{0, 1, \dots, 4\}$ to $\{0, 1, 2\}$ by

$$f(s(\sigma, x)) = \begin{cases} 1 & \text{if } s(\sigma, x) = 2 \\ 2 & \text{if } s(\sigma, x) = 3 \\ 0 & \text{otherwise.} \end{cases}$$

On the one hand, by definition of $N_-(\mathcal{L}_N^\sigma)$ and $N_+(\mathcal{L}_N^\sigma)$, we have

$$\sum_{x \in \mathbb{Z}^2 \cap N\mathcal{S}_N} \sigma(x) f(s(\sigma, x)) = N_+(\mathcal{L}_N^\sigma) - N_-(\mathcal{L}_N^\sigma),
 \tag{13}$$

on the other hand, we deduce from the definition of the function f ,

$$\sum_{x \in \mathbb{Z}^2 \cap N\mathcal{S}_N} \sigma(x)f(s(\sigma, x)) = - \sum_{x \in \mathbb{Z}^2, \Lambda_{x/N} \subset \mathcal{S}_N} (\mathbb{I}_{\sigma(x)=-1, s(\sigma, x)=2} - \mathbb{I}_{\sigma(x)=+1, s(\sigma, x)=2}) - 2 \sum_{x \in \mathbb{Z}^2, \Lambda_{x/N} \subset \mathcal{S}_N} (\mathbb{I}_{\sigma(x)=-1, s(\sigma, x)=3} - \mathbb{I}_{\sigma(x)=+1, s(\sigma, x)=3})$$

We combine the last formula, Lemma 1 (with $\alpha = 1/2$) together with the fact that $\mathbb{I}_{s(\sigma, x)=4} = 0$, and we obtain

$$v_N(L_N^{\sigma, \gamma}(s, r, \alpha_1, \alpha_2)) = -\frac{1}{2} v_N \left(\sum_{x \in \mathbb{Z}^2 \cap \mathcal{S}_N} \sigma(x)f(s(\sigma, x)) \right). \tag{14}$$

The statement of Proposition 3 follows from (13) and (14) by taking the expectation with respect to v_N . □

In view of Proposition 3, in order to control $v_N(L_N^{\sigma, \gamma}(s, r, \alpha_1, \alpha_2))$, it remains to evaluate $v_N(N_+(L_N^\sigma) - N_-(L_N^\sigma))$. For this, we begin by controlling the quantity $N_+(\mathcal{L}_N) - N_-(\mathcal{L}_N)$ for monotone deterministic paths \mathcal{L}_N defined as follows.

Definition 2 *A path on \mathbb{Z}_N^2 is said to be monotone if all its horizontal as well as all its vertical vectors are oriented in the same sense.*

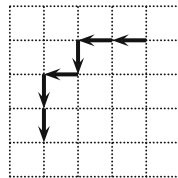

A monotone path on the grid \mathbb{Z}_N^2

The following lemma evaluates $N_+(\mathcal{L}_N) - N_-(\mathcal{L}_N)$, whenever \mathcal{L}_N is a monotone path on \mathbb{Z}_N^2 .

Lemma 2 *Let $(v_i)_{1 \leq i \leq r}$ be a sequence of r consecutive vectors drawn on the grid \mathbb{Z}_N^2 . These vectors are enumerated beginning from $N^{-1}u_e := v_1$ until $N^{-1}u_s := v_r$. We suppose that they form a monotone path on \mathbb{Z}_N^2 , say \mathcal{L}_N . Let $[u_e \wedge u_s] = (u_e \cdot i)(u_s \cdot j) - (u_e \cdot j)(u_s \cdot i)$. Then*

$$N_+(\mathcal{L}_N) - N_-(\mathcal{L}_N) = [u_e \wedge u_s].$$

Remark Let us note that for any path $\mathcal{L}_N = (v_1, \dots, v_r)$, we have

$$\widehat{(u_e, u_s)} = \frac{\pi}{2} (N_-(\mathcal{L}_N) - N_+(\mathcal{L}_N)),$$

where $u_e = Nv_1$ and $u_s = Nv_r$.

Proof of Lemma 2 We denote by $\mathcal{L}_N(r) = (v_1, \dots, v_r)$ a monotone path on \mathbb{Z}_N^2 . The proof of Lemma 2 is done by induction on r .

For $r = 1$, we have $N_-(\mathcal{L}_N(1)) - N_+(\mathcal{L}_N(1)) = 0$ which corresponds to $[u_e \wedge u_s]$, since in this case $N^{-1}u_e = N^{-1}u_s = v_1$.

We suppose now that the property is true at step $r \geq 1$ and we prove it at step $r + 1$. We consider the path $\mathcal{L}_N(r + 1)$. Since $\mathcal{L}_N(r + 1)$ is monotone, we can suppose without loss of generality that

$$(\mathcal{H}) \quad \forall l \in \{1, \dots, r + 1\} \quad (Nv_l) \cdot i \in \{0, -1\}, \quad (Nv_l) \cdot j \in \{0, -1\}.$$

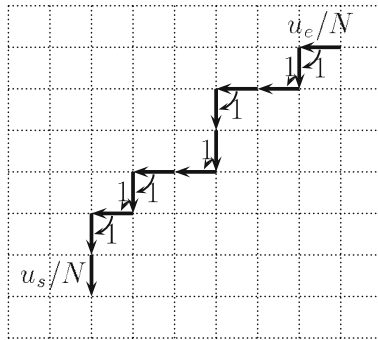

For this monotone path \mathcal{L}_N , we have $u_e = (-1, 0)$ and $u_s = (0, -1)$,

hence $[u_e \wedge u_s] = 1$. On the other hand $N_+(\mathcal{L}_N) - N_-(\mathcal{L}_N) = 1 - 1 + 1 - 1 + 1 - 1 + 1 - 1 = 1$

Once the hypothesis (\mathcal{H}) is assumed, we have only three cases to discuss on the expression of (v_r, v_{r+1}) ,

- If $v_r = v_{r+1}$, then $N_+(\mathcal{L}_N(r + 1)) - N_-(\mathcal{L}_N(r + 1)) = N_+(\mathcal{L}_N(r)) - N_-(\mathcal{L}_N(r))$, and the inductive assumption gives

$$N_+(\mathcal{L}_N(r + 1)) - N_-(\mathcal{L}_N(r + 1)) = [Nv_1 \wedge Nv_{r+1}].$$

- If $(Nv_r) \cdot j = -1 = (Nv_{r+1}) \cdot i$, then $\widehat{(v_r, v_{r+1})} = \frac{\pi}{2}$ and $N_+(\mathcal{L}_N(r + 1)) - N_-(\mathcal{L}_N(r + 1)) = N_+(\mathcal{L}_N(r)) - N_-(\mathcal{L}_N(r)) - 1$. Together with the inductive assumption, this gives

$$\begin{aligned} N_+(\mathcal{L}_N(r + 1)) - N_-(\mathcal{L}_N(r + 1)) &= -(Nv_1) \cdot i - 1 \\ &= (Nv_1) \cdot j = [Nv_1 \wedge Nv_{r+1}]. \end{aligned}$$

- If $(Nv_r) \cdot i = -1 = (Nv_{r+1}) \cdot j$, then $\widehat{(v_r, v_{r+1})} = -\frac{\pi}{2}$, $N_+(\mathcal{L}_N(r + 1)) - N_-(\mathcal{L}_N(r + 1)) = N_+(\mathcal{L}_N(r)) - N_-(\mathcal{L}_N(r)) + 1$ and

$$\begin{aligned} N_+(\mathcal{L}_N(r + 1)) - N_-(\mathcal{L}_N(r + 1)) &= (Nv_1) \cdot j + 1 \\ &= -(Nv_1) \cdot i = [Nv_1 \wedge Nv_{r+1}]. \end{aligned}$$

The equality $N_+(\mathcal{L}_N(r+1)) - N_-(\mathcal{L}_N(r+1)) = [Nv_1 \wedge Nv_{r+1}]$ is then always valid and Lemma 2 is proved. \square

The following lemma generalizes Lemma 2. Its purpose is to evaluate $N_+(\mathcal{L}_N) - N_-(\mathcal{L}_N)$ for a path \mathcal{L}_N constructed by concatenating two monotone paths.

Lemma 3 *Let $\mathcal{L}_N = (v_1, \dots, v_r, w_1, \dots, w_s)$ be a path on \mathbb{Z}_N^2 . Suppose that (v_1, \dots, v_r) (respectively (w_1, \dots, w_s)) forms a monotone path on \mathbb{Z}_N^2 and that $v_r \cdot w_1 = 0$. Let $a_1, a_2, b_1, b_2 \in \{-1, +1\}$. Suppose that for each $1 \leq i \leq r$ (resp. $1 \leq j \leq s$), the vector Nv_i (resp. Nw_j) is either $(a_1, 0)$ (resp. $(b_1, 0)$) or $(0, a_2)$ (resp. $(0, b_2)$). Then,*

$$N_-(\mathcal{L}_N) - N_+(\mathcal{L}_N) = -a_2(Nv_1) \cdot i + b_2(Nw_s) \cdot i + f(a_1, a_2, b_1, b_2), \tag{15}$$

where i is the unit vector $(1, 0)$, \cdot is the usual scalar product in \mathbb{R}^2 and

$$f(a_1, a_2, b_1, b_2) = \begin{cases} 2a_1a_2 & \text{if } a_2b_2 = -1, \quad ((Nv_r) \cdot i = a_1 \text{ or } a_1b_1 = 1) \\ 2b_1a_2 & \text{if } a_2b_2 = -1, \quad (Nv_r) \cdot i = 0 \\ 0 & \text{if } a_2b_2 = 1. \end{cases}$$

Proof of Lemma 3 We deduce, applying Lemma 2 to the monotone paths (v_1, \dots, v_r) , (w_1, \dots, w_s) and (v_r, w_1) that, for $\mathcal{L}_N = (v_1, \dots, v_r, w_1, \dots, w_s)$,

$$N_+(\mathcal{L}_N) - N_-(\mathcal{L}_N) = [Nv_1 \wedge Nv_r] + [Nv_r \wedge Nw_1] + [Nw_1 \wedge Nw_s]. \tag{16}$$

In the following picture, we have $Nv_1 = (1, 0)$, $Nv_r = (0, -1)$, $Nw_1 = (-1, 0)$, $Nw_s = (-1, 0)$. Hence $[Nv_1 \wedge Nv_r] + [Nw_1 \wedge Nw_s] + [Nv_r \wedge Nw_1] = -2$. On the other hand, we have $N_+(\mathcal{L}_N) - N_-(\mathcal{L}_N) = -2$.

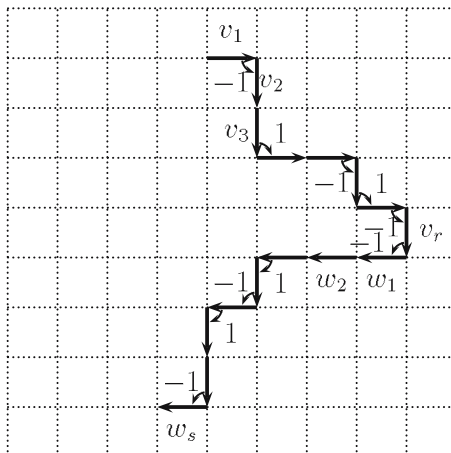

We deduce from

$$(Nv_l) \cdot i \in \{0, a_1\}, \quad \text{and} \quad (Nv_l) \cdot j \in \{0, a_2\},$$

for $1 \leq l \leq r$, that

$$a_1(Nv_l) \cdot i + a_2(Nv_l) \cdot j = 1.$$

This fact gives

$$[Nv_1 \wedge Nv_r] = a_2(Nv_1) \cdot i - a_2(Nv_r) \cdot i. \tag{17}$$

In the same way, we deduce that for any $1 \leq l \leq s$,

$$b_1(Nw_l) \cdot i + b_2(Nw_l) \cdot j = 1, \quad [Nw_1 \wedge Nw_s] = b_2(Nw_1) \cdot i - b_2(Nw_s) \cdot i. \tag{18}$$

We also have, since $v_r \cdot w_1 = 0$,

$$[Nv_r \wedge Nw_1] = b_2(Nv_r) \cdot i - a_2(Nw_1) \cdot i. \tag{19}$$

We obtain, collecting (17), (18), (19) and (16),

$$N_+(\mathcal{L}_N) - N_-(\mathcal{L}_N) = a_2(Nv_1) \cdot i - b_2(Nw_s) \cdot i + (b_2 - a_2)((Nv_r) \cdot i + (Nw_1) \cdot i).$$

From, the last equality we deduce the following,

- If $a_2 = b_2$ i.e. $a_2b_2 = 1$, then $N_-(\mathcal{L}_N) - N_+(\mathcal{L}_N) = -a_2(Nv_1) \cdot i + b_2(Nw_s) \cdot i$.
- If $a_2b_2 = -1$ then since $v_r \cdot w_1 = 0$, $(Nv_r) \cdot i + (Nw_1) \cdot i \in \{a_1, b_1\}$ and

$$N_-(\mathcal{L}_N) - N_+(\mathcal{L}_N) + a_2(Nv_1) \cdot i - b_2(Nw_s) \cdot i$$

is either $2a_1a_2$ or $2b_1a_2$. □

The following corollary evaluates $N_-(\mathcal{L}_N) - N_+(\mathcal{L}_N)$ for a path \mathcal{L}_N behaving like a polygonal line. It will be very useful for the control of $L_N^{\sigma, \gamma}(s, r, \alpha_1, \alpha_2)$.

Corollary 1 *Let s_0, s_1 and s_2 be three points in \mathbb{R}^2 . Let θ_0 (resp. θ_1) be the oriented angle between the half horizontal axis $[0, +\infty[$ and the segment $[s_1, s_0[$ (respectively $[s_1, s_2[$). Let $\mathcal{L}_N = (v_1, \dots, v_r, w_1, \dots, w_s)$ be a path on \mathbb{Z}_N^2 . Suppose that the family (v_1, \dots, v_r) (respectively (w_1, \dots, w_s)) forms a monotone path on \mathbb{Z}_N^2 and that $v_r \cdot w_1 = 0$. Suppose moreover that (v_1, \dots, v_r) and $[s_0, s_1[$ (respectively (w_1, \dots, w_s) and $[s_1, s_2[$) are either both non-increasing or either both non-decreasing. Then*

$$N_-(\mathcal{L}_N) - N_+(\mathcal{L}_N) = \text{sgn}(\sin \theta_0)(Nv_1) \cdot i + \text{sgn}(\sin \theta_1)(Nw_s) \cdot i + f(\theta_1, \theta_0), \tag{20}$$

where

$$f(\theta_1, \theta_0) = \begin{cases} 2\text{sgn}(\theta_1 - \theta_0) & \text{if } \sin \theta_0 \sin \theta_1 > 0, \quad \cos \theta_0 \cos \theta_1 > 0, \\ 2\text{sgn}(\tan \theta_0) & \text{if } \sin \theta_0 \sin \theta_1 > 0, \quad \cos \theta_0 \cos \theta_1 < 0, \\ 0 & \text{otherwise.} \end{cases}$$

We illustrate the conclusion of the previous corollary with the help of the following pictures.

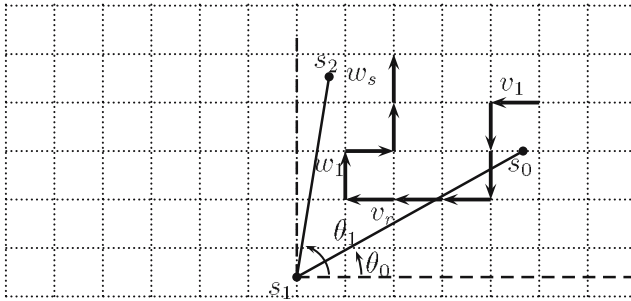

\mathcal{L}_N is the circuit $(v_1, \dots, v_r, w_1, \dots, w_s)$.
Here, $f(\theta_1, \theta_0) = 2\text{sgn}(\theta_1 - \theta_0) = 2$

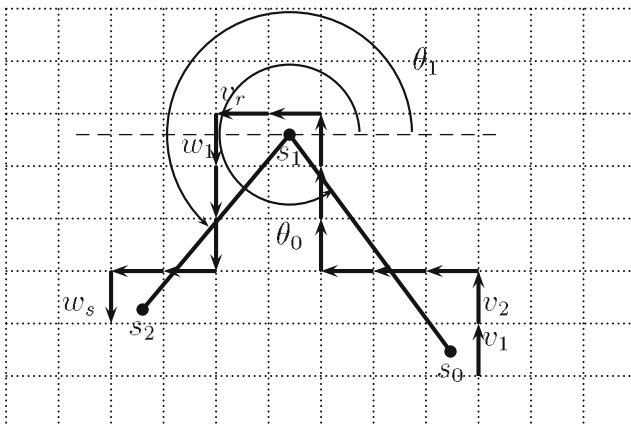

\mathcal{L}_N is the circuit $(v_1, \dots, v_r, w_1, \dots, w_s)$.
Here, $f(\theta_1, \theta_0) = 2\text{sgn}(\tan \theta_0) = -2$

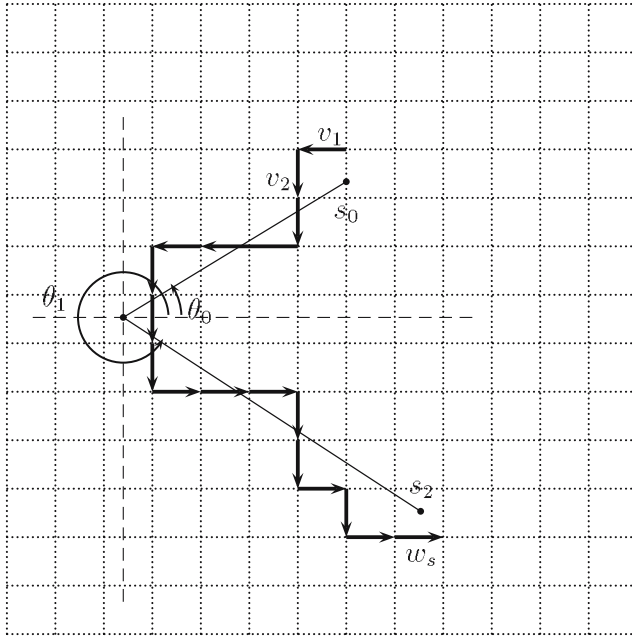

In this picture, $f(\theta_1, \theta_0) = 0$

Proof of Corollary 1 We first check that for any $1 \leq l \leq r$, $(Nv_l) \cdot i \in \{0, -\text{sgn}(\cos \theta_0)\}$, and $(Nv_l) \cdot j \in \{0, -\text{sgn}(\sin \theta_0)\}$. In the same way, we have for $1 \leq l \leq s$,

$$(Nw_l) \cdot i \in \{0, \text{sgn}(\cos \theta_1)\}, \quad \text{and} \quad (Nw_l) \cdot j \in \{0, \text{sgn}(\sin \theta_1)\}.$$

Lemma 3 gives then

$$N_-(\mathcal{L}_N) - N_+(\mathcal{L}_N) = \text{sgn}(\sin \theta_0)(Nv_1) \cdot i + \text{sgn}(\sin \theta_1)(Nw_s) \cdot i + f(\theta_1, \theta_0),$$

where

- If $a_2b_2 = -\text{sgn}(\sin \theta_0)\text{sgn}(\sin \theta_1) > 0$, then $f(\theta_1, \theta_0) = 0$.
- If $\text{sgn}(\sin \theta_0)\text{sgn}(\sin \theta_1) > 0$ and $\text{sgn}(\cos \theta_0)\text{sgn}(\cos \theta_1) < 0$, then $f(\theta_1, \theta_0) = 2\text{sgn}(\tan \theta_0)$.
In fact this case corresponds to $a_2b_2 = -1, a_1 = -\text{sgn}(\cos \theta_0) = \text{sgn}(\cos \theta_1) = b_1$.

Now we have to discuss the case $\text{sgn}(\sin \theta_0)\text{sgn}(\sin \theta_1) > 0$ and $\text{sgn}(\cos \theta_0)\text{sgn}(\cos \theta_1) > 0$ i.e. when $a_2b_2 = -1$ and $a_1b_1 = -1$. We distinguish all the cases on the possible values of (a_1, a_2) and we deduce the following: $(Nv_r) \cdot i = 0$ if and only if $(a_1a_2 < 0$ and $\theta_0 < \theta_1)$ or $(a_1a_2 > 0$ and $\theta_0 > \theta_1)$. So $(Nv_r) \cdot i = 0$ if

and only if $a_1 a_2 \operatorname{sgn}(\theta_0 - \theta_1) > 0$. We apply again Lemma 3 and we deduce that in this last case $f(\theta_1, \theta_0) = 2 \operatorname{sgn}(\theta_1 - \theta_0)$. \square

We have now all the ingredients in order to evaluate $v_N (N_- (\mathcal{L}_N^\sigma) - N_+ (\mathcal{L}_N^\sigma))$ for the random path \mathcal{L}_N^σ as defined by (10). The curve γ is of class \mathcal{C}_1 , hence for r small enough, the part of γ situated between x_0 and s (resp. between s and x_1) is either nondecreasing or nonincreasing. We conclude from the assumptions of Theorem 1 that, for N large enough and with probability one, the random path \mathcal{L}_N^σ respects the behavior of the curve γ , thus \mathcal{L}_N^σ is either monotone or it is constructed by concatenating two monotone paths, say $\mathcal{L}_N^\sigma = (\mathcal{L}_{1,N}^\sigma, \mathcal{L}_{2,N}^\sigma)$. These monotone paths are such that, noting by s' the point of $T_{x_0}\gamma \cap T_{x_1}\gamma$, $\mathcal{L}_{1,N}^\sigma$ and $[x_0, s']$ (resp. $\mathcal{L}_{2,N}^\sigma$ and $[s', x_1]$) are either both nondecreasing or both nonincreasing. Corollary 1 applies and gives, for N large enough,

$$v_N (N_- (\mathcal{L}_N^\sigma) - N_+ (\mathcal{L}_N^\sigma)) = \operatorname{sgn}(\sin \theta_0) v_N (e_N^1(\alpha_1) \cdot i) + \operatorname{sgn}(\sin \theta_1) v_N (e_N^2(\alpha_2) \cdot i) + f(\theta_1, \theta_0),$$

the function $f(\theta_1, \theta_0)$ is defined in Corollary 1, the angles θ_1, θ_0 are those defined by Theorem 1, the random vectors $e_N^1(\alpha_1), e_N^2(\alpha_2)$ are the two unit vectors as defined by (9). We then deduce from Proposition 3 that there exists N_0 depending only on γ such that, for any $N \geq N_0$, we have,

$$v_N (L_N^{\sigma,\gamma}(s, r, \alpha_1, \alpha_2)) = \frac{1}{2} \operatorname{sgn}(\sin \theta_0) v_N (e_N^1(\alpha_1) \cdot i) + \frac{1}{2} \operatorname{sgn}(\sin \theta_1) v_N (e_N^2(\alpha_2) \cdot i) + \frac{1}{2} f(\theta_1, \theta_0).$$

5.2 Evaluation of $\int_0^\delta \int_0^\delta v_N (L_N^{\sigma,\gamma}(s, r, \alpha_1, \alpha_2)) d\alpha_1 d\alpha_2$

By the previous formula, in order to evaluate the quantity

$$\int_0^\delta \int_0^\delta v_N (L_N^{\sigma,\gamma}(s, r, \alpha_1, \alpha_2)) d\alpha_1 d\alpha_2,$$

for δ and r small enough, it suffices to evaluate the terms

$$v_N \left(\int_0^\delta e_N^1(\alpha) \cdot i d\alpha \right), \quad v_N \left(\int_0^\delta e_N^2(\alpha) \cdot i d\alpha \right).$$

We begin by the first quantity, for this we need some further notations.

Notation For a vector v drawn on the grid \mathbb{Z}_N^2 , we denote by $R(v)$ the union of the two boxes of the family $(\Lambda_{x/N})_{x \in \mathbb{Z}^2}$ having v as an edge vector.

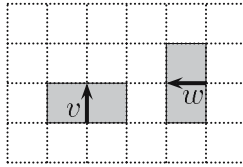

The two blocks $R(v)$ and $R(w)$

Let $\mathcal{L}_N^\sigma = (v_1, \dots, v_r)$ be the oriented path as defined by (10). Let $\mathcal{L}_{1,N}^\sigma = (v_1, \dots, v_s)$ be the subgraph of \mathcal{L}_N^σ included in $\partial \mathcal{A}_\sigma^N \cap (B(x_0, \delta))_N$ such that the vector v_s is the entering vector in $(B(s, r))_N$.

To each vector v_l ($1 \leq l \leq s$), we associate the block $R_{s-l+1} := R(v_l)$. These blocks $(R_l)_{1 \leq l \leq s}$ are enumerated according to their distances to x_0 , R_1 being the block containing v_s . Let $(a_l)_{1 \leq l \leq s}$ be the sequence of vertices such that

$$d_l := d(x_0, R_l) = |a_l - x_0|,$$

then this sequence of vertices $(a_l)_{1 \leq l \leq s}$ is L^1 connected and the vector $a_l a_{l+1}$ is either vertical or horizontal. Finally, let \mathcal{H}_N be the set of indices $l \in \{1, \dots, s\}$ for which v_l is horizontal.

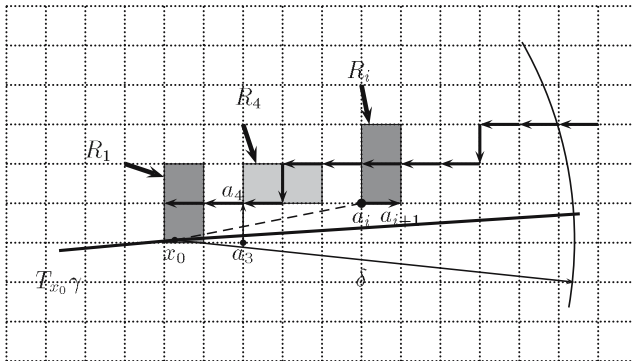

$$d_l = d(x_0, R_l) = |x_0 - a_l|.$$

For N large enough, the vector $a_l a_{l+1}$ is either horizontal or vertical, and $|a_l - a_{l+1}| = 1/N$

With probability one, the path $\mathcal{L}_{1,N}^\sigma$ is monotone and behaves, on a neighborhood of x_0 , as $T_{x_0} \gamma$. This fact ensures that, with probability one, $e_N^1(\alpha) \cdot i \in \{0, -\text{sgn}(\cos \theta_0)\}$. Now, by construction $e_N^1(\alpha) \cdot i = -\text{sgn}(\cos \theta_0)$ if and only if there exists $l \in \mathcal{H}_N$ such that $\alpha \in]d_l, d_{l+1}[$ (such an index is necessarily unique).

With probability one,

$$\left| \int_0^\delta e_N^1(\alpha) \cdot i \, d\alpha + \operatorname{sgn}(\cos \theta_0) \sum_{l \in \mathcal{H}_N(x_0, \delta)} (d_{l+1} - d_l) \right| \leq \frac{2}{N}, \tag{21}$$

where $\mathcal{H}_N(x_0, \delta)$ is the set of all the horizontal edges of ∂A_N^σ included in $(B(x_0, \delta))_N \setminus B(s, r)$. In order to evaluate $d_{l+1} - d_l$, we need the following lemma.

Lemma 4 *Let u and v be two vectors such that $\|u\| \leq \|v\|$. Then*

$$\|u + v\| - \|v\| = \frac{(u + v) \cdot u}{\|u + v\|} - \frac{\|u\|^2}{\|v\|} \frac{\sin^2 \theta}{1 + \sqrt{1 - \frac{\|u\|^2}{\|v\|^2} \sin^2 \theta}},$$

where θ is the angle between u and $u + v$.

Proof of Lemma 4 Let u, v and θ be as defined in Lemma 4.

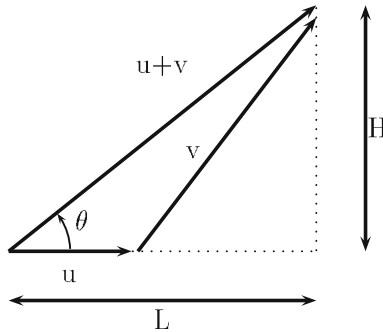

We have

$$\begin{aligned} \|u + v\|^2 &= L^2 + H^2 \\ &= \cos^2 \theta \|u + v\|^2 + \|v\|^2 - (\cos \theta \|u + v\| - \|u\|)^2 \\ &= \|v\|^2 + 2 \cos \theta \|u\| \times \|u + v\| - \|u\|^2. \end{aligned}$$

The quantity $\|u + v\|$ is then a positive solution of an algebraic equation of degree two. We deduce from $\|u\| \leq \|v\|$, that

$$\|u + v\| = \|u\| \cos \theta + \sqrt{\|v\|^2 - \sin^2 \theta \|u\|^2}.$$

Hence

$$\begin{aligned} \|u + v\| - \|v\| &= \|u\| \cos \theta + \|v\| \left(\sqrt{1 - \sin^2 \theta \frac{\|u\|^2}{\|v\|^2}} - 1 \right) \\ &= \|u\| \cos \theta - \frac{\|u\|^2}{\|v\|} \frac{\sin^2 \theta}{1 + \sqrt{1 - \frac{\|u\|^2}{\|v\|^2} \sin^2 \theta}}. \end{aligned}$$

The last equality together with the fact that $\|u\| \cos \theta = \frac{(u + v) \cdot u}{\|u + v\|}$ proves Lemma 4. □

We continue the proofs of Theorems 1 and 2. We apply Lemma 4 with $u = a_l a_{l+1}$, $v = x_0 a_l$ and we get

$$\frac{(u + v) \cdot u}{\|u + v\|} = \frac{(x_0 a_{l+1}) \cdot (a_l a_{l+1})}{|x_0 - a_{l+1}|}.$$

Moreover, we deduce from Lemma 4,

$$\left| d_{l+1} - d_l - \frac{(x_0 a_{l+1}) \cdot (a_l a_{l+1})}{|x_0 - a_{l+1}|} \right| \leq \min \left(\frac{1}{N^2 |x_0 - a_l|}, \frac{2}{N} \right). \tag{22}$$

We first evaluate the sum over $l \in \mathcal{H}_N(x_0, \delta)$ of the right hand side of the last inequality. Let $\phi(l)$ be the cardinality of the set $\mathcal{H}_N(x_0, \delta) \cap \{1, \dots, l\}$. For $l \in \mathcal{H}_N(x_0, \delta)$, we have $|x_0 a_l| \cdot i \geq N^{-1}(\phi(l) - 1)$, whence

$$\sum_{l \in \mathcal{H}_N(x_0, \delta)} \min \left(\frac{1}{N^2 |x_0 - a_l|}, \frac{2}{N} \right) \leq \frac{1}{N} \sum_{l \in \mathcal{H}_N} \min \left(\frac{1}{\phi(l) - 1}, 2 \right) \leq \frac{2 + \ln |\mathcal{H}_N|}{N}. \tag{23}$$

With probability one, we have

$$\text{sgn}(\cos \theta_0)(a_l a_{l+1}) \cdot i + \text{sgn}(\sin \theta_0)(a_l a_{l+1}) \cdot j = \frac{1}{N},$$

whence

$$\begin{aligned} &\sum_{l \in \mathcal{H}_N(x_0, \delta)} \frac{(x_0 a_{l+1}) \cdot (a_l a_{l+1})}{|x_0 - a_{l+1}|} \\ &= \frac{\text{sgn}(\cos \theta_0)}{N} \sum_{l \in \mathcal{H}_{1,N}(x_0, \delta)} \frac{(x_0 a_{l+1}) \cdot i}{|x_0 - a_{l+1}|} + \frac{\text{sgn}(\sin \theta_0)}{N} \sum_{l \in \mathcal{H}_{2,N}(x_0, \delta)} \frac{(x_0 a_{l+1}) \cdot j}{|x_0 - a_{l+1}|}, \end{aligned} \tag{24}$$

where

$$\begin{aligned} \mathcal{H}_{1,N}(x_0, \delta) &= \{l \in \mathcal{H}_N(x_0, \delta) : (a_l a_{l+1}) \cdot j = 0\}, \\ \mathcal{H}_{2,N}(x_0, \delta) &= \{l \in \mathcal{H}_N(x_0, \delta) : (a_l a_{l+1}) \cdot i = 0\}. \end{aligned} \tag{25}$$

We now distinguish the case of the polygons and the case of the Jordan curves.

5.3 End of the proof for polygons (Theorem 1)

Lemma 5 *For δ small enough, we have*

$$\begin{aligned} \lim_{N \rightarrow \infty} \left| v_N \left(\frac{1}{N} \sum_{l \in \mathcal{H}_{1,N}(x_0, \delta)} \frac{(x_0 a_{l+1}) \cdot i}{|x_0 - a_{l+1}|} \right) - v_N \left(\frac{|\mathcal{H}_{1,N}(x_0, \delta)|}{N} \right) \cos \theta_0 \right| &= 0, \\ \lim_{N \rightarrow \infty} \left| v_N \left(\frac{1}{N} \sum_{l \in \mathcal{H}_{2,N}(x_0, \delta)} \frac{(x_0 a_{l+1}) \cdot j}{|x_0 - a_{l+1}|} \right) - v_N \left(\frac{|\mathcal{H}_{2,N}(x_0, \delta)|}{N} \right) \sin \theta_0 \right| &= 0. \end{aligned}$$

Proof of Lemma 5 We only prove the first limit since the argument for the second limit is similar. Let u be a unit vector tangent to γ at x_0 and let v be such that (u, v) is a direct basis. For $\varepsilon > 0$, let $\mathcal{R}(\varepsilon)$ be the strip of width 2ε centered on the tangent line $T_{x_0}\gamma$, i.e.,

$$\mathcal{R}(\varepsilon) = \{x \in \mathbb{R}^2 : |x_0 x \cdot v| \leq \varepsilon\}.$$

The condition (3) implies that for δ small enough,

$$\forall \varepsilon > 0 \quad \lim_{N \rightarrow +\infty} v_N (\partial \mathcal{A}_N^\sigma \cap B(x_0, \delta) \subset \mathcal{R}(\varepsilon)) = 1.$$

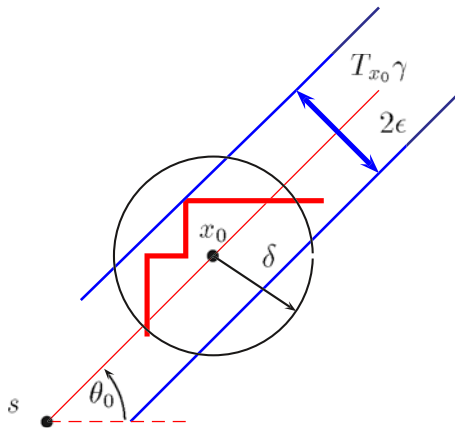

For δ small enough, $\lim_{N \rightarrow +\infty} v_N (\partial \mathcal{A}_N^\sigma \cap B(x_0, \delta) \subset \mathcal{R}(\varepsilon)) = 1$

Let $\delta > 0$ be small enough so that the above limit holds. Let δ_0, ε such that $0 < \varepsilon < \delta_0 < \delta$ and let $x \in \mathcal{R}(\varepsilon) \setminus B(x_0, \delta_0)$. We have

$$\begin{aligned} x_0x \cdot i &= (x_0x \cdot u) \cos \theta_0 - (x_0x \cdot v) \sin \theta_0, \\ |x_0 - x|^2 &= (x_0x \cdot u)^2 + (x_0x \cdot v)^2, \end{aligned}$$

whence

$$\frac{x_0x \cdot i}{|x_0 - x|} = \left(1 - \frac{(x_0x \cdot v)^2}{|x_0 - x|^2}\right)^{1/2} \cos \theta_0 - \frac{(x_0x \cdot v)}{|x_0 - x|} \sin \theta_0$$

and

$$\left| \frac{x_0x \cdot i}{|x_0 - x|} - \cos \theta_0 \right| \leq 1 - \sqrt{1 - \varepsilon^2/\delta_0^2} + \frac{\varepsilon}{\delta_0} \leq 2\frac{\varepsilon}{\delta_0}.$$

If the event $\{\partial \mathcal{A}_N^\sigma \cap B(x_0, \delta) \subset \mathcal{R}(\varepsilon)\}$ occurs, then for $l \in \mathcal{H}_N(x_0, \delta) \setminus \mathcal{H}_N(x_0, \delta_0)$, we have $a_{l+1} \in \mathcal{R}(\varepsilon) \setminus B(x_0, \delta_0)$, and thus

$$\limsup_{N \rightarrow \infty} v_N \left(\sup_{l \in \mathcal{H}_N(x_0, \delta) \setminus \mathcal{H}_N(x_0, \delta_0)} \left| \frac{(x_0a_{l+1}) \cdot i}{|x_0 - a_{l+1}|} - \cos \theta_0 \right| \right) \leq 2\frac{\varepsilon}{\delta_0}.$$

Moreover, we have $|\mathcal{H}_N(x_0, \delta_0)| \leq 2N\delta_0$, whence, by splitting the sum over $\mathcal{H}_N(x_0, \delta_0)$ and $\mathcal{H}_N(x_0, \delta) \setminus \mathcal{H}_N(x_0, \delta_0)$, we obtain

$$\limsup_{N \rightarrow \infty} \left| v_N \left(\frac{1}{N} \sum_{l \in \mathcal{H}_{1,N}(x_0, \delta)} \frac{(x_0a_{l+1}) \cdot i}{|x_0 - a_{l+1}|} \right) - v_N \left(\frac{|\mathcal{H}_{1,N}(x_0, \delta)|}{N} \right) \cos \theta_0 \right| \leq 4\frac{\delta\varepsilon}{\delta_0} + 4\delta_0.$$

We conclude by sending successively ε to 0 and δ_0 to 0. □

We obtain, combining (24) and lemma 5, that for δ small enough,

$$\begin{aligned} \lim_{N \rightarrow \infty} \left| v_N \left(\sum_{l \in \mathcal{H}_N(x_0, \delta)} \frac{(x_0a_{l+1}) \cdot (a_l a_{l+1})}{|x_0 - a_{l+1}|} \right) \right. \\ \left. - \left(v_N \left(\frac{|\mathcal{H}_{1,N}(x_0, \delta)|}{N} \right) |\cos \theta_0| + v_N \left(\frac{|\mathcal{H}_{2,N}(x_0, \delta)|}{N} \right) |\sin \theta_0| \right) \right| = 0. \end{aligned} \tag{26}$$

Our purpose now is to evaluate, for N large enough, the expectations over v_N of $|\mathcal{H}_N(x_0, \delta)|/N$, $|\mathcal{H}_{1,N}(x_0, \delta)|/N$ and $|\mathcal{H}_{2,N}(x_0, \delta)|/N$. For this, we prove the following lemma.

Lemma 6 For δ small enough, one has

$$\lim_{N \rightarrow +\infty} \nu_N \left(\frac{|\mathcal{H}_N(x_0, \delta)|}{N} \right) = \delta |\cos \theta_0|. \tag{27}$$

Proof of Lemma 6 We denote by a and x' the points of $\partial B(x_0, \delta) \setminus B(s, r)$ belonging respectively to $\partial \mathcal{A}_N^\sigma$ and to $T_{x_0} \gamma$. Let b be the point of $\partial \mathcal{A}_N^\sigma \cap \partial B(s, r) \setminus B(x_1, \delta)$. We suppose without loss of generality that $(ba) \cdot i \geq 0$.

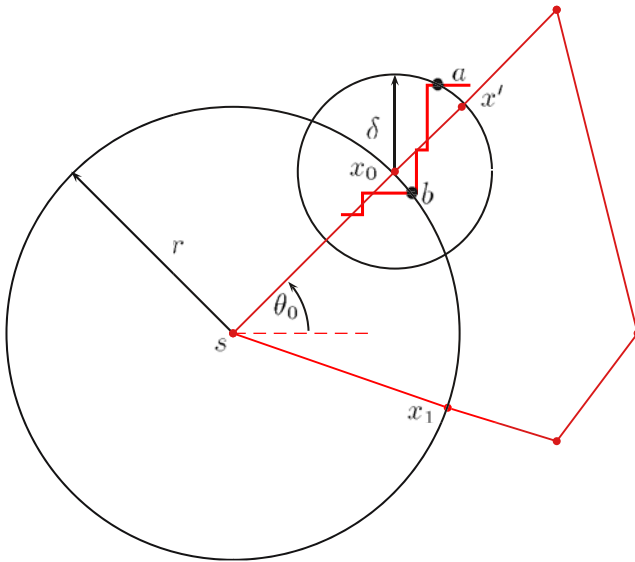

In this case, γ is a polygon. The proportion of the horizontal edges of $\partial \mathcal{A}_N^\sigma$ which are in $B(x_0, \delta) \setminus B(s, r)$ is controlled by $\delta |\cos \theta_0|$

We have, by definition of $\mathcal{H}_N(x_0, \delta)$,

$$\left| \frac{|\mathcal{H}_N(x_0, \delta)|}{N} - |ba \cdot i| \right| \leq \frac{2}{N}.$$

We use the same notation as in the proof of Lemma 5. We have

$$\bigcap_{\varepsilon > 0} \mathcal{R}(\varepsilon) \cap \partial B(x_0, \delta) \setminus B(s, r) = T_{x_0} \gamma \cap \partial B(x_0, \delta) \setminus B(s, r) = \{x'\},$$

$$\bigcap_{\varepsilon > 0} \mathcal{R}(\varepsilon) \cap \partial B(s, r) \setminus B(x_1, \delta) = T_{x_0} \gamma \cap \partial B(s, r) \setminus B(x_1, \delta) = \{x_0\}.$$

Let $\alpha > 0$. By the above identities, there exists $\varepsilon > 0$ such that, if $\partial\mathcal{A}_N^\sigma \cap B(x_0, \delta) \subset \mathcal{R}(\varepsilon)$, then $|b - x_0| < \alpha$ and $|a - x'| < \alpha$. Now, the condition (3) implies that for δ small enough,

$$\lim_{N \rightarrow +\infty} \nu_N (\partial\mathcal{A}_N^\sigma \cap B(x_0, \delta) \subset \mathcal{R}(\varepsilon)) = 1.$$

Putting together the previous facts, we obtain that

$$\limsup_{N \rightarrow +\infty} \left| \nu_N \left(\frac{|\mathcal{H}_N(x_0, \delta)|}{N} \right) - |x_0 x' \cdot i| \right| \leq 2\alpha.$$

Remarking that $|x_0 x' \cdot i| = \delta |\cos \theta_0|$, we conclude the proof by sending α to 0. □

Now, let $\mathcal{L}_{1,N}^\sigma$ be the monotone path (v_1, \dots, v_s) as defined in the Sub-Sect. 5.2. We obtain using the definition of $\mathcal{H}_{2,N}(x_0, \delta)$, that $|\mathcal{H}_{2,N}(x_0, \delta)|$ is either $N_+(\mathcal{L}_{1,N}^\sigma)$ or $N_-(\mathcal{L}_{1,N}^\sigma)$. This fact together with the constation that $|N_+(\mathcal{L}_{1,N}) - N_-(\mathcal{L}_{1,N})| \leq 1$, gives

$$\left| \frac{|\mathcal{H}_{2,N}(x_0, \delta)|}{N} - \frac{N_+(\mathcal{L}_{1,N}^\sigma)}{N} \right| \leq \frac{1}{N}.$$

Condition (4) together with the last inequality ensures, since $|\mathcal{H}_{2,N}(x_0, \delta) - C_N(x_0, \delta)| \leq 1$,

$$\lim_{N \rightarrow +\infty} \nu_N \left(\frac{|\mathcal{H}_{2,N}(x_0, \delta)|}{N} \right) = \delta C(\theta_0). \tag{28}$$

The two sets of indices $\mathcal{H}_{1,N}(x_0, \delta)$ and $\mathcal{H}_{2,N}(x_0, \delta)$ form a partition of $\mathcal{H}_N(x_0, \delta)$, hence

$$\lim_{N \rightarrow +\infty} \left| \nu_N \left(\frac{|\mathcal{H}_{1,N}(x_0, \delta)|}{N\delta} \right) - (|\cos \theta_0| - C(\theta_0)) \right| = 0. \tag{29}$$

We obtain, collecting (21), (22), (23), (26), (28), (29) that

$$\begin{aligned} & \lim_{N \rightarrow \infty} \left| \frac{1}{\delta} \nu_N \left(\int_0^\delta e_N^1(\alpha) \cdot i \, d\alpha \right) \right. \\ & \left. + \operatorname{sgn}(\cos \theta_0) (\cos^2 \theta_0 + C(\theta_0) (|\sin \theta_0| - |\cos \theta_0|)) \right| = 0. \end{aligned}$$

Using the same method, we prove that

$$\lim_{N \rightarrow \infty} \left| \frac{1}{\delta} \nu_N \left(\int_0^\delta e_N^2(\alpha) \cdot i \, d\alpha \right) - \operatorname{sgn}(\cos \theta_1) (\cos^2 \theta_1 + C(\theta_1)(|\sin \theta_1| - |\cos \theta_1|)) \right| = 0.$$

We finish the proof of Theorem 1 by combining Proposition 3 together with the two last limits. □

5.4 End of the proof for Jordan curves (Theorem 2)

To extend the proofs to Jordan curves, we have to generalize Lemmas 5 and 6 as follows.

Lemma 7 *We have*

$$\lim_{\delta \rightarrow 0} \limsup_{N \rightarrow \infty} \left| \nu_N \left(\frac{1}{\delta N} \sum_{l \in \mathcal{H}_{1,N}(x_0, \delta)} \frac{(x_0 a_{l+1}) \cdot i}{|x_0 - a_{l+1}|} \right) - \nu_N \left(\frac{|\mathcal{H}_{1,N}(x_0, \delta)|}{N} \right) \cos \theta_0 \right| = 0,$$

$$\lim_{\delta \rightarrow 0} \limsup_{N \rightarrow \infty} \left| \nu_N \left(\frac{1}{\delta N} \sum_{l \in \mathcal{H}_{2,N}(x_0, \delta)} \frac{(x_0 a_{l+1}) \cdot j}{|x_0 - a_{l+1}|} \right) - \nu_N \left(\frac{|\mathcal{H}_{2,N}(x_0, \delta)|}{N} \right) \sin \theta_0 \right| = 0.$$

Proof of Lemma 7 We only prove the first limit since the argument for the second limit is similar. Let u be a unit vector tangent to γ at x_0 and let v be such that (u, v) is a direct basis. For $\varepsilon > 0$, let $\mathcal{R}(\varepsilon)$ be the strip of width 2ε centered on the tangent line $T_{x_0}\gamma$, i.e.,

$$\mathcal{R}(\varepsilon) = \{ x \in \mathbb{R}^2 : |x_0 x \cdot v| \leq \varepsilon \}.$$

Since $T_{x_0}\gamma$ is the tangent to γ at x_0 , we have

$$\lim_{\delta \rightarrow 0} \frac{1}{\delta} d_H(\gamma \cap B(x_0, \delta), T_{x_0}\gamma \cap B(x_0, \delta)) = 0. \tag{30}$$

Let $0 < \varepsilon < 1$, there exists $\delta_0 > 0$ such that, for $\delta < \delta_0$,

$$d_H(\gamma \cap B(x_0, \delta), T_{x_0}\gamma \cap B(x_0, \delta)) \leq \varepsilon \delta / 4.$$

This fact together with condition (3) implies that there exists $\delta_1 > 0$ such that

$$\forall \delta < \delta_1 \quad \lim_{N \rightarrow +\infty} \nu_N (\partial \mathcal{A}_N^\sigma \cap B(x_0, \delta) \subset \mathcal{R}(\varepsilon\delta/2)) = 1.$$

Let $\delta > 0$ be such that $\delta < \min(\delta_0, \delta_1)$. Let $x \in \mathcal{R}(\varepsilon\delta) \setminus B(x_0, \sqrt{\varepsilon}\delta)$. We have

$$\begin{aligned} x_0x \cdot i &= (x_0x \cdot u) \cos \theta_0 - (x_0x \cdot v) \sin \theta_0, \\ |x_0 - x|^2 &= (x_0x \cdot u)^2 + (x_0x \cdot v)^2, \end{aligned}$$

whence

$$\frac{x_0x \cdot i}{|x_0 - x|} = \left(1 - \frac{(x_0x \cdot v)^2}{|x_0 - x|^2}\right)^{1/2} \cos \theta_0 - \frac{(x_0x \cdot v)}{|x_0 - x|} \sin \theta_0$$

and

$$\left| \frac{x_0x \cdot i}{|x_0 - x|} - \cos \theta_0 \right| \leq 1 - \sqrt{1 - \varepsilon} + \sqrt{\varepsilon} \leq 2\sqrt{\varepsilon}.$$

If the event $\{\partial \mathcal{A}_N^\sigma \cap B(x_0, \delta) \subset \mathcal{R}(\varepsilon\delta/2)\}$ occurs, then $a_{l+1} \in \mathcal{R}(\varepsilon\delta) \setminus B(x_0, \sqrt{\varepsilon}\delta)$ for $l \in \mathcal{H}_N(x_0, \delta) \setminus \mathcal{H}_N(x_0, \sqrt{\varepsilon}\delta)$, and thus

$$\limsup_{N \rightarrow \infty} \nu_N \left(\sup_{l \in \mathcal{H}_N(x_0, \delta) \setminus \mathcal{H}_N(x_0, \sqrt{\varepsilon}\delta)} \left| \frac{(x_0a_{l+1}) \cdot i}{|x_0 - a_{l+1}|} - \cos \theta_0 \right| \right) \leq 2\sqrt{\varepsilon}.$$

Moreover, we have $|\mathcal{H}_N(x_0, \sqrt{\varepsilon}\delta)| \leq 2N\delta\sqrt{\varepsilon}$, whence, by splitting the sum over $\mathcal{H}_N(x_0, \sqrt{\varepsilon}\delta)$ and $\mathcal{H}_N(x_0, \delta) \setminus \mathcal{H}_N(x_0, \sqrt{\varepsilon}\delta)$, we obtain

$$\limsup_{N \rightarrow \infty} \left| \nu_N \left(\frac{1}{\delta N} \sum_{l \in \mathcal{H}_{1,N}(x_0, \delta)} \frac{(x_0a_{l+1}) \cdot i}{|x_0 - a_{l+1}|} \right) - \nu_N \left(\frac{|\mathcal{H}_{1,N}(x_0, \delta)|}{N\delta} \right) \cos \theta_0 \right| \leq 8\sqrt{\varepsilon}.$$

This inequality being valid for all δ small enough, the proof is completed. □

Lemma 8 *We have*

$$\lim_{\delta \rightarrow 0} \limsup_{N \rightarrow +\infty} \left| \nu_N \left(\frac{|\mathcal{H}_N(x_0, \delta)|}{\delta N} \right) - |\cos \theta_0| \right| = 0. \tag{31}$$

Proof of Lemma 8 We denote, as in the proof of Lemma 6, by a and x' the points of $\partial B(x_0, \delta) \setminus B(s, r)$ belonging respectively to $\partial \mathcal{A}_N^\sigma$ and to γ . Let b be the point of $\partial \mathcal{A}_N^\sigma \cap \partial B(s, r) \setminus B(x_1, \delta)$.

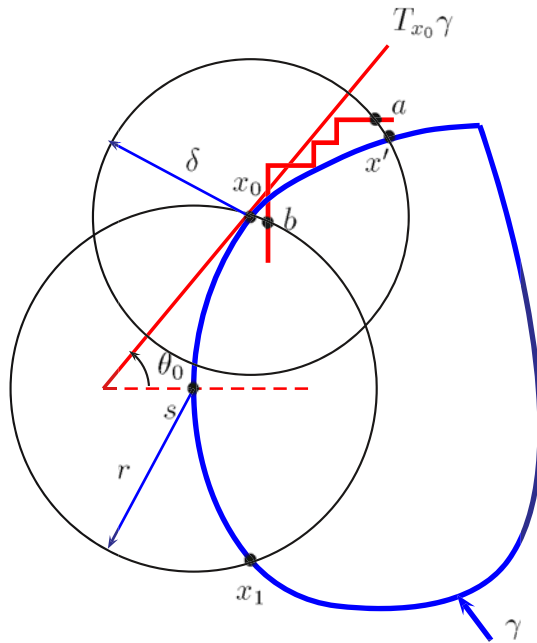

The random points a and b are approximated, for N large enough, respectively by x' and x_0

We have, by definition of $\mathcal{H}_N(x_0, \delta)$,

$$\left| \frac{|\mathcal{H}_N(x_0, \delta)|}{N} - |ba \cdot i| \right| \leq \frac{2}{N}.$$

We suppose that r is small enough so that $T_{x_0}\gamma$ is not tangent to the circle $\partial B(s, r)$. Let $\alpha > 0$. There exists $\varepsilon > 0$ depending on α and the angle of the tangent $T_{x_0}\gamma$ with $\partial B(s, r)$ such that

$$\forall \delta > 0 \quad \{ \partial \mathcal{A}_N^\sigma \cap B(x_0, \delta) \subset \mathcal{R}(\varepsilon\delta) \} \Rightarrow |b - x_0| < \alpha\delta, \quad |a - x'| < \alpha\delta.$$

Now as in the proof of Lemma 7, the condition (3) together with (30) implies that for δ small enough,

$$\lim_{N \rightarrow +\infty} \nu_N \left(\partial \mathcal{A}_N^\sigma \cap B(x_0, \delta) \subset \mathcal{R}(\varepsilon\delta) \right) = 1.$$

Putting together the previous facts, we obtain that

$$\limsup_{N \rightarrow +\infty} \left| \nu_N \left(\frac{|\mathcal{H}_N(x_0, \delta)|}{N} \right) - |x_0 x' \cdot i| \right| \leq 2\alpha\delta.$$

Remarking that $|x_0 - x'| = \delta$, and that

$$\lim_{\delta \rightarrow 0} \frac{|x_0 x' \cdot i|}{|x_0 - x'|} = |\cos \theta_0|,$$

we conclude the proof by sending α to 0. □

Corollary 2 *We have*

$$\lim_{\delta \rightarrow 0} \limsup_{N \rightarrow +\infty} \left| \nu_N \left(\frac{|\mathcal{H}_{1,N}(x_0, \delta)|}{\delta N} \right) - (|\cos \theta_0| - C(\theta_0)) \right| = 0. \tag{32}$$

$$\lim_{\delta \rightarrow 0} \limsup_{N \rightarrow +\infty} \left| \nu_N \left(\frac{|\mathcal{H}_{2,N}(x_0, \delta)|}{\delta N} \right) - C(\theta_0) \right| = 0. \tag{33}$$

Proof of Corollary 2 The limit in (33) is deduced from the condition (6) since by definition

$$|\mathcal{H}_{2,N}(x_0, \delta) - C_N(x_0, \delta)| \leq \frac{1}{N}.$$

The first limit is deduced by combining (33) and the result of Lemma 8, since $\mathcal{H}_{2,N}(x_0, \delta)$ and $\mathcal{H}_{1,N}(x_0, \delta)$ form a partition of $\mathcal{H}_N(x_0, \delta)$. □

We obtain, collecting (21), (22), (23), (24), Lemma 7, (32) and (33) that

$$\begin{aligned} & \lim_{\delta \rightarrow 0} \limsup_{N \rightarrow \infty} \left| \frac{1}{\delta} \nu_N \left(\int_0^\delta e_N^1(\alpha) \cdot i \, d\alpha \right) \right. \\ & \left. + \operatorname{sgn}(\cos \theta_0) (\cos^2 \theta_0 + C(\theta_0) (|\sin \theta_0| - |\cos \theta_0|)) \right| = 0. \end{aligned}$$

Using the same method, we prove that

$$\begin{aligned} & \lim_{\delta \rightarrow 0} \limsup_{N \rightarrow \infty} \left| \frac{1}{\delta} \nu_N \left(\int_0^\delta e_N^2(\alpha) \cdot i \, d\alpha \right) \right. \\ & \left. - \operatorname{sgn}(\cos \theta_1) (\cos^2 \theta_1 + C(\theta_1) (|\sin \theta_1| - |\cos \theta_1|)) \right| = 0. \end{aligned}$$

We get the expression of $\lim_{\delta \rightarrow 0} \limsup_{N \rightarrow \infty} \nu_N(\mathbf{A}_N^{\sigma, \gamma}(s, r, \delta))$ of Theorem 2 by combining Proposition 3 together with the two last limits. The lim inf can be handled similarly. □

5.5 Proof of Proposition 1

In this case the condition 3 of Theorem 1 is satisfied and we have only to check the limit in (6) and to precise the value of the function C defined there. For this, we need the following lemma.

Lemma 9 *Let A and B be two points of \mathbb{R}^2 . For each fixed integer N , let \mathcal{L}_N denote one of the two maximal subpaths of $\partial([AB]_N)$ not crossing the line (AB) . Let $N_+(\mathcal{L}_N)$ be as defined in (11). Then*

$$\lim_{N \rightarrow +\infty} \frac{N_+(\mathcal{L}_N)}{N} = |(AB) \cdot i| \wedge |(AB) \cdot j|,$$

where $a \wedge b = \min(a, b)$.

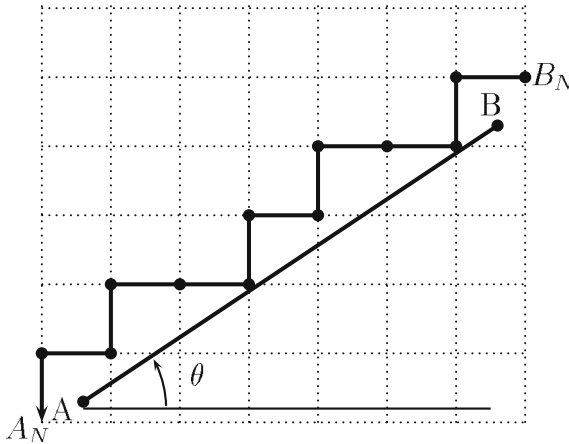

Proof of Lemma 9 We suppose without loss of generality that $AB \cdot i$ and $AB \cdot j$ are positive. Let θ denote the angle between AB and i . We consider only the case $0 \leq \tan \theta < 1$, since the proofs for the cases $\tan \theta > 1$ and $\tan \theta = 1$ are similar. We denote by A_N and B_N the extreme points of \mathcal{L}_N . Our task is to prove that

$$(A_N B_N) \cdot j = \frac{N_+(\mathcal{L}_N)}{N}. \tag{34}$$

The identity (34) will prove Lemma 9 since $\lim_{N \rightarrow +\infty} (A_N B_N) \cdot j = (AB) \cdot j$ and $0 \leq \tan \theta < 1$.

We first prove the equality (34) for $N_+(\mathcal{L}_N) = 1$. When $N_+(\mathcal{L}_N) = 1$, the path \mathcal{L}_N contains a unique monotone path $\mathcal{L}'_N = (v_1, w_1, \dots, w_r)$ such that $v_1 \cdot j = 0$, $v_1 \cdot w_1 = 0$ and $w_1 \cdot i = \dots = w_r \cdot i = 0$. These vectors are drawn on the lattice \mathbb{Z}_N^2 and arranged according to the direct sense.

Let C_1, C_2 be the two points of (AB) such that $(C_1C_2) \cdot i = 1/N$ and that the path \mathcal{L}'_N cover the segment $[C_1, C_2]$. By construction

$$(C_1C_2) \cdot j > \frac{r-1}{N},$$

hence

$$\tan \theta = \frac{(C_1C_2) \cdot j}{(C_1C_2) \cdot i} > r - 1.$$

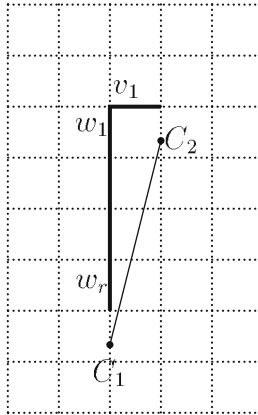

Since $0 \leq \tan \theta < 1$, we deduce that $r = 1$. Now let B_1, B_2 be the two points of (AB) belonging to the boundary of the box of $[AB]_N$ that contains the point B . Since $0 \leq \tan \theta < 1$, we have

$$|(B_1B_2) \cdot j| < \frac{1}{N}.$$

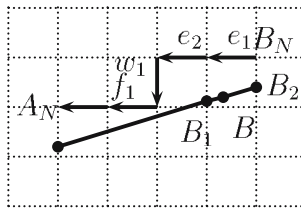

This fact together with $r = 1$ proves that the path \mathcal{L}_N is equal to $(e_1, \dots, e_m, w_1, f_1, \dots, f_n)$, where the vectors (e_i) and (f_i) are copies of the vector v_1 , so that they are all horizontal. Hence $(A_NB_N) \cdot j = 1/N$. The general case when $N_+(\mathcal{L}_N) > 1$ is proved by induction on $N_+(\mathcal{L}_N)$. \square

Proof of polygons Lemma 9 together with Theorem 1 yield the control of $\mathbf{A}_N^{\sigma, \Gamma}$ (s, r, δ) for a class of regular polygons Γ defined as follows.

m-smooth polygons Let s_1, \dots, s_m be m points of \mathbb{R}^2 . We denote by $\Gamma(s_1, \dots, s_m)$ or by Γ , if there is no ambiguities, the polygon in \mathbb{R}^2 linking the points $[s_1, s_2, \dots, s_m, s_1]$; the points s_1, s_2, \dots, s_m are then the corner points of Γ . We suppose that the points s_1, s_2, \dots, s_m are arranged counterclockwise. By convention, we set $s_0 = s_m$. To each site s_i , we associate two oriented angles $\theta_i(s_i)$ and $\theta_{i-1}(s_i)$ such that $\theta_{i-1}(s_i)$ (respectively $\theta_i(s_i)$) is the oriented angle between the half horizontal axis $[0, +\infty[$ and the segment $[s_i, s_{i-1}[$ (respectively $[s_i, s_{i+1}[$).

Finally, we suppose that Γ encloses a connected, compact, bounded set U of \mathbb{R}^2 i.e. $\Gamma = \partial U$ and that $\Gamma \cap \mathbb{Z}^2/N = \emptyset$ for all $N \geq 1$.

Initial condition We will consider σ the spin configuration associated to the polygon Γ at step N .

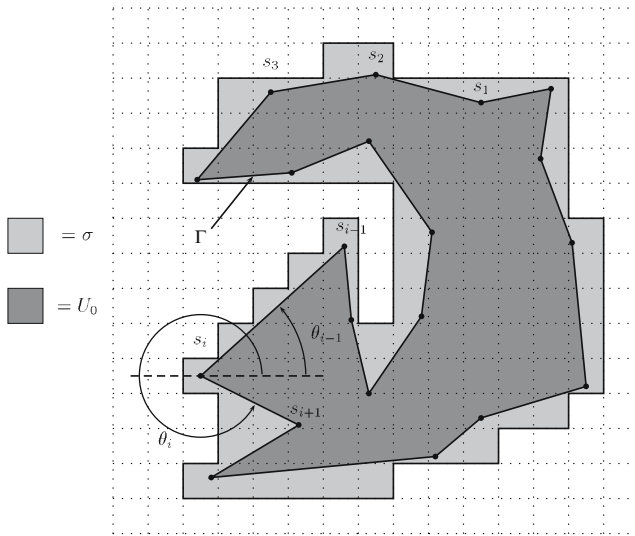

A polygon Γ and the configuration σ

Lemma 9 allows to apply Theorem 1 with $C(\theta_k) = |\sin \theta_k| \wedge |\cos \theta_k|$. Doing so, we get the following proposition.

Proposition 4 Let Γ be an m -smooth polygon in \mathbb{R}^2 associated to the m points s_1, \dots, s_m and let $\sigma_0 := \sigma_{0,N}$ be the associated initial configuration at step N . Let $\theta_i \in [0, 2\pi]$ (respectively $\theta_{i-1} \in [0, 2\pi]$) be the oriented angle between the half horizontal axis $[0, +\infty[$ and the segment $[s_i, s_{i+1}[$ (respectively $[s_i, s_{i-1}[$) with the convention that $s_0 = s_m$. Then, for each $i = 1, \dots, m$, and for any positive real numbers r, δ small enough, one has

$$\lim_{N \rightarrow +\infty} \mathbf{A}_N^{\sigma, \Gamma}(s_i, r, \delta) = \frac{1}{4} \sin 2\theta_{i-1} (2\mathbb{I}_{|\sin \theta_{i-1}| < |\cos \theta_{i-1}|} - 1) - \frac{1}{4} \sin 2\theta_i (2\mathbb{I}_{|\sin \theta_i| < |\cos \theta_i|} - 1) + \frac{1}{2} (\text{sgn}(\tan \theta_i) \mathbb{I}_{|\sin \theta_i| < |\cos \theta_i|})$$

$$-\operatorname{sgn}(\tan \theta_{i-1})\mathbb{I}_{|\sin \theta_{i-1}| < |\cos \theta_{i-1}|} + \mathbb{I}_{\sin \theta_{i-1} \sin \theta_i > 0} (\operatorname{sgn}(\theta_i - \theta_{i-1}) \times \mathbb{I}_{\cos \theta_{i-1} \cos \theta_i > 0} + \operatorname{sgn}(\tan \theta_{i-1})\mathbb{I}_{\cos \theta_{i-1} \cos \theta_i < 0}).$$

Hence,

- if $(\theta_{i-1}, \theta_i) \in [(2k+1)\frac{\pi}{4}, (2k+3)\frac{\pi}{4}] \times [(2k+5)\frac{\pi}{4}, (2k+7)\frac{\pi}{4}]$, with $k \in \{0, 2\}$, then

$$\lim_{N \rightarrow +\infty} \mathbf{A}_N^{\sigma, \Gamma}(s_i, r, \delta) = \frac{1}{4} (\sin 2\theta_i - \sin 2\theta_{i-1}).$$

- if $(\theta_{i-1}, \theta_i) \in [(2k+1)\frac{\pi}{4}, (2k+3)\frac{\pi}{4}] \times [(2k+5)\frac{\pi}{4}, (2k+7)\frac{\pi}{4}]$, with $k \in \{1, 3\}$, then

$$\lim_{N \rightarrow +\infty} \mathbf{A}_N^{\sigma, \Gamma}(s_i, r, \delta) = \frac{1}{4} (\sin 2\theta_{i-1} - \sin 2\theta_i).$$

- if $(\theta_{i-1}, \theta_i) \in [(2k+1)\frac{\pi}{4}, (2k+3)\frac{\pi}{4}]^2$, with $k \in \{0, 2\}$, then

$$\lim_{N \rightarrow +\infty} \mathbf{A}_N^{\sigma, \Gamma}(s_i, r, \delta) = \frac{1}{4} (4 \operatorname{sgn}(\theta_i - \theta_{i-1}) + \sin 2\theta_i - \sin 2\theta_{i-1}).$$

- if $(\theta_{i-1}, \theta_i) \in [(2k+1)\frac{\pi}{4}, (2k+3)\frac{\pi}{4}]^2$, with $k \in \{1, 3\}$, then

$$\lim_{N \rightarrow +\infty} \mathbf{A}_N^{\sigma, \Gamma}(s_i, r, \delta) = \frac{1}{4} (4 \operatorname{sgn}(\sin(\theta_i - \theta_{i-1})) + \sin 2\theta_{i-1} - \sin 2\theta_i).$$

- if $(\theta_{i-1}, \theta_i) \in [(2k+1)\frac{\pi}{4}, (2k+3)\frac{\pi}{4}] \times [(2k+3)\frac{\pi}{4}, (2k+5)\frac{\pi}{4}] \cup [(2k+3)\frac{\pi}{4}, (2k+5)\frac{\pi}{4}] \times [(2k+1)\frac{\pi}{4}, (2k+3)\frac{\pi}{4}]$, with $k \in \{0, 2\}$, then

$$\lim_{N \rightarrow +\infty} \mathbf{A}_N^{\sigma, \Gamma}(s_i, r, \delta) = \begin{cases} \frac{1}{4} (2 - \sin 2\theta_i - \sin 2\theta_{i-1}) & \text{if } |\tan \theta_i| \leq 1, |\tan \theta_{i-1}| \geq 1 \\ \frac{1}{4} (-2 + \sin 2\theta_{i-1} + \sin 2\theta_i) & \text{if } |\tan \theta_i| \geq 1, |\tan \theta_{i-1}| \leq 1. \end{cases}$$

- if $(\theta_{i-1}, \theta_i) \in [(2k+1)\frac{\pi}{4}, (2k+3)\frac{\pi}{4}] \times [(2k+3)\frac{\pi}{4}, (2k+5)\frac{\pi}{4}] \cup [(2k+3)\frac{\pi}{4}, (2k+5)\frac{\pi}{4}] \times [(2k+1)\frac{\pi}{4}, (2k+3)\frac{\pi}{4}]$, with $k \in \{1, 3\}$, then

$$\lim_{N \rightarrow +\infty} \mathbf{A}_N^{\sigma, \Gamma}(s_i, r, \delta) = \begin{cases} \frac{1}{4} (-2 - \sin 2\theta_i - \sin 2\theta_{i-1}) & \text{if } |\tan \theta_i| \leq 1, |\tan \theta_{i-1}| \geq 1 \\ \frac{1}{4} (2 + \sin 2\theta_{i-1} + \sin 2\theta_i) & \text{if } |\tan \theta_i| \geq 1, |\tan \theta_{i-1}| \leq 1. \end{cases}$$

Remark We denote by $L_\Gamma(s_i) = \lim_{N \rightarrow +\infty} \mathbf{A}_N^{\sigma, \Gamma}(s_i, r, \delta)$, where Γ is a polygon as described by Proposition 4. Then we can check the following comparison criterion.

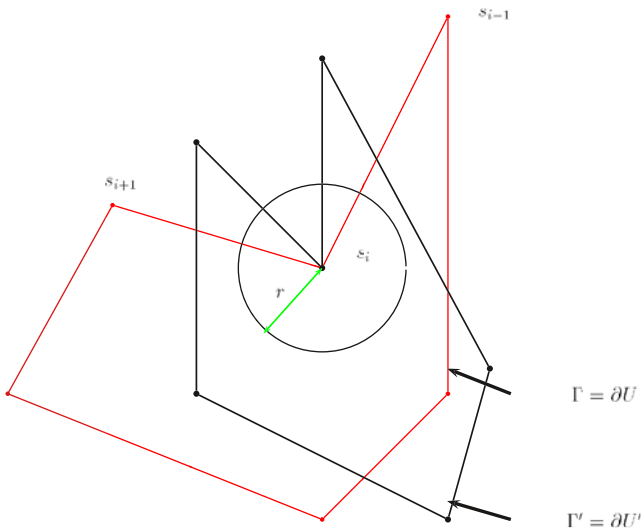

If $U \cap B(s_i, r) \subset U' \cap B(s_i, r)$ for some $r > 0$ and $s_i \in \Gamma \cap \Gamma'$,
 then $L_\Gamma(s_i) \leq L_{\Gamma'}(s_i)$

We illustrate the results of Proposition 4 with the help of the following pictures.

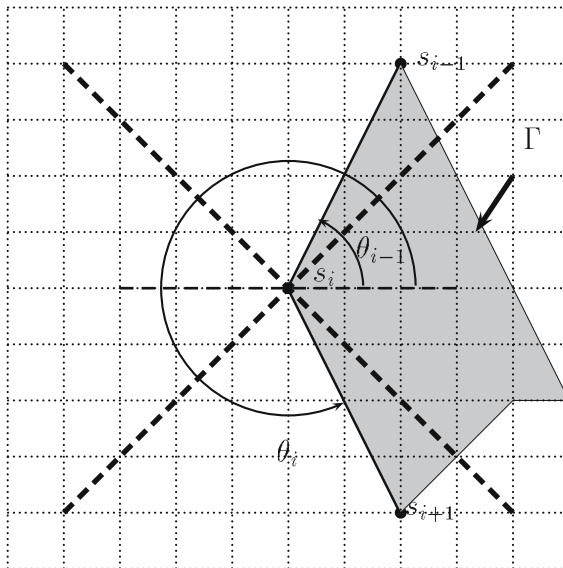

Here $\lim_{N \rightarrow +\infty} \mathbf{A}_N^{\sigma, \Gamma}(s_i, r, \delta) = \frac{1}{4} (\sin 2\theta_i - \sin 2\theta_{i-1})$.

In the first picture this limit is negative, while for the second one it is positive

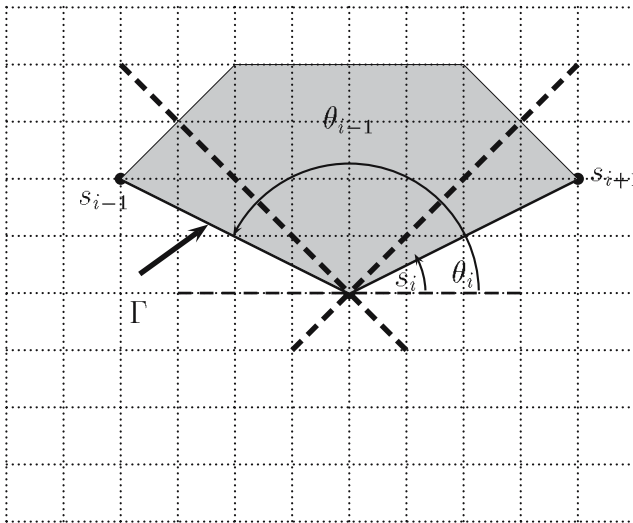
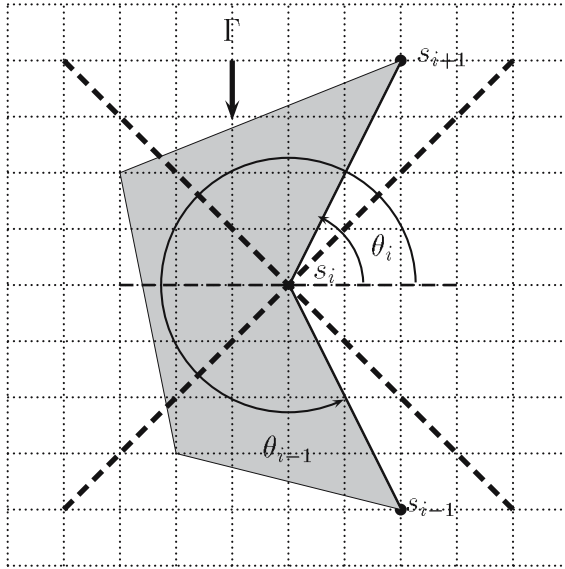

In the following picture, we have $\lim_{N \rightarrow +\infty} \mathbf{A}_N^{\sigma, \Gamma}(s_i, r, \delta) = \frac{1}{4} (\sin 2\theta_{i-1} - \sin 2\theta_i)$.

This limit is negative

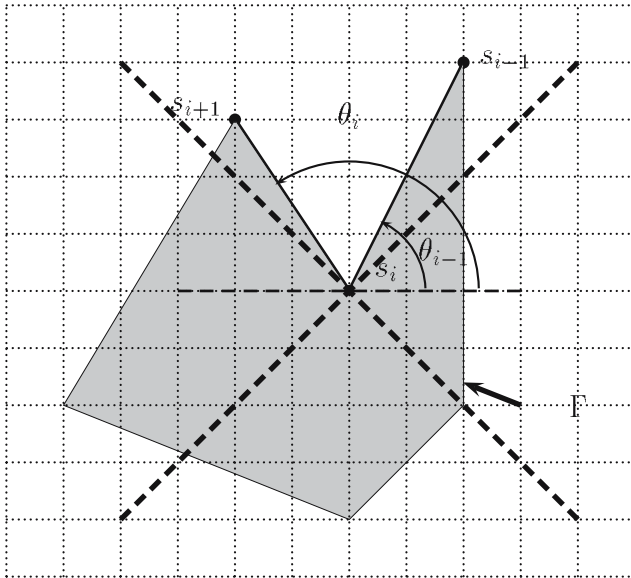

Here $\lim_{N \rightarrow +\infty} \mathbf{A}_N^{\sigma, \Gamma}(s_i, r, \delta) = \frac{1}{4} (4 + \sin 2\theta_i - \sin 2\theta_{i-1})$.
 This limit is positive

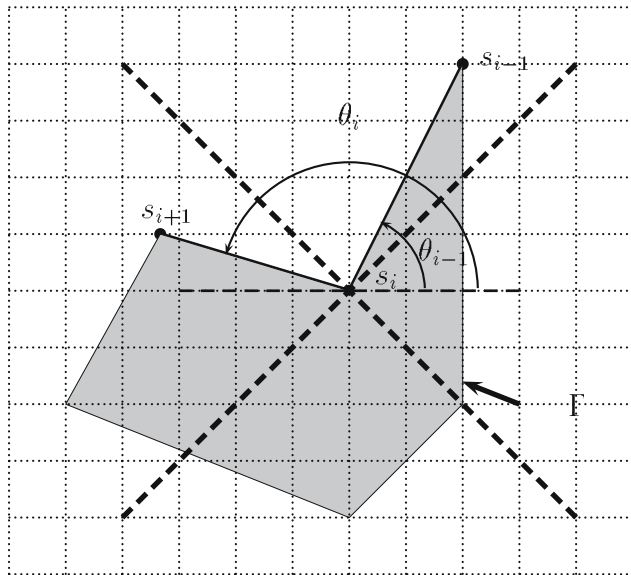

In the following picture, we have $\lim_{N \rightarrow +\infty} \mathbf{A}_N^{\sigma, \Gamma}(s_i, r, \delta) = \frac{1}{4} (2 - \sin 2\theta_{i-1} - \sin 2\theta_i)$.
 This limit is positive

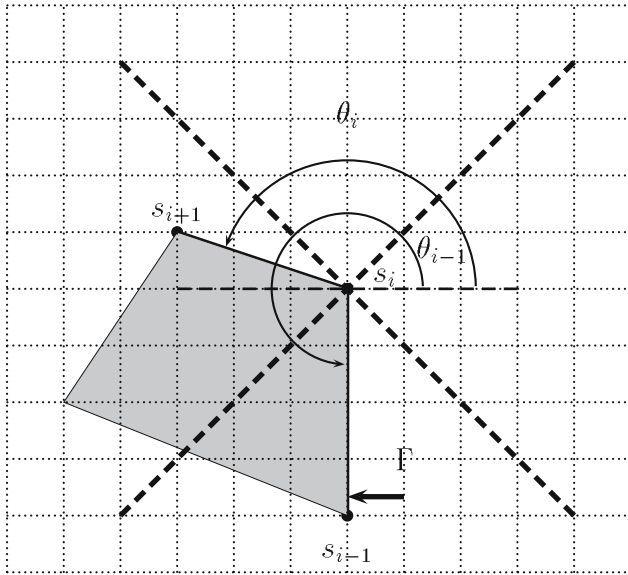

Here $\lim_{N \rightarrow +\infty} \mathbf{A}_N^{\sigma, \Gamma}(s_i, r, \delta) = \frac{1}{4} (-2 - \sin 2\theta_i - \sin 2\theta_{i-1})$.
 This limit is negative

Proof for Jordan curves We consider now the case of Jordan curves. In order to apply Theorem 2, we have to check the condition (6). For this, we generalize Lemma 9 as follows.

Lemma 10 *Let f be a monotone function of class C_1 defined on $[a, b]$. Let \mathcal{L}_N denote one of the two maximal subpaths of \mathbb{Z}_N^2 covering f . Let $N_+(\mathcal{L}_N)$ be as defined in (11). Then*

$$\lim_{N \rightarrow +\infty} \frac{N_+(\mathcal{L}_N)}{N} = \int_a^b (|f'(x)| \wedge 1) dx.$$

Proof of Lemma 10 We suppose without loss of generality that the function f is nondecreasing on $[a, b]$. Let $(I_i)_{i \in I}$ be the collection of the open intervals where $f' - 1$ is nonzero. Setting $I_i =]x_{i-1}, x_i[$ for $i \in I$, we have

$$\left(\frac{f(x_i) - f(x_{i-1})}{x_i - x_{i-1}} \right) \wedge 1 = \frac{1}{x_i - x_{i-1}} \int_{x_{i-1}}^{x_i} (f'(x) \wedge 1) dx. \tag{35}$$

We denote by f_i the restriction of f to $[x_{i-1}, x_i]$ and by $\mathcal{L}_N^{(i)}$ the associated polygonal line. We deduce from the suitable construction of the intervals $(I_i)_{i \in I}$ and

arguing as in the proof of Lemma 9, that

$$\lim_{N \rightarrow +\infty} \frac{N_+(\mathcal{L}_N^{(i)})}{N} = (x_i - x_{i-1}) \wedge (f(x_i) - f(x_{i-1})).$$

Hence

$$\lim_{N \rightarrow +\infty} \frac{N_+(\mathcal{L}_N)}{N} = \sum_{i \in I} (x_i - x_{i-1}) \wedge (f(x_i) - f(x_{i-1})).$$

Lemma 10 is proved by collecting the last bound together with (35). □

We define a monotone function f , such that the part of γ limited by x_0 and $x_0(\delta)$ (where $x_0(\delta)$ is the point of $\gamma \cap \partial B(x_0, \delta) \setminus B(s, r)$) is equal to the graph $\{(x, y) : y = f(x)\}$ and we apply Lemma 10 to the monotone path \mathcal{L}_N covering the part of γ limited by x_0 and $x_0(\delta)$. We deduce, since $|N_+(\mathcal{L}_N) - C_N(x_0, \delta)| \leq 1$, that

$$\begin{aligned} \lim_{N \rightarrow +\infty} \frac{C_N(x_0, \delta)}{N\delta} &= \frac{1}{\delta} \int_{I_\delta} (|f'(x)| \wedge 1) \, dx \\ &= |\cos \theta(\delta)| \frac{1}{I_\delta} \int_{I_\delta} (|f'(x)| \wedge 1) \, dx, \end{aligned}$$

where I_δ is the segment $[x_0 \cdot i, x_0(\delta) \cdot i]$. We obtain, taking the limit over $\delta \rightarrow 0$ in the last equality,

$$\lim_{\delta \rightarrow 0} \lim_{N \rightarrow +\infty} \frac{C_N(x_0, \delta)}{N\delta} = |\cos \theta_0| (|f'(x_0 \cdot i)| \wedge 1) = |\cos \theta_0| \wedge |\sin \theta_0|.$$

We then obtain from the conclusion of Theorem 2, that for r small enough,

$$\lim_{\delta \rightarrow 0} \liminf_{N \rightarrow +\infty} \mathbf{A}_N^{\sigma, \gamma}(s, r, \delta) = \lim_{\delta \rightarrow 0} \limsup_{N \rightarrow +\infty} \mathbf{A}_N^{\sigma, \gamma}(s, r, \delta) \tag{36}$$

$$\begin{aligned} &= \frac{1}{4} \sin 2\theta_0 \left(2\mathbb{I}_{|\sin \theta_0| < |\cos \theta_0| - 1} \right) \\ &\quad - \frac{1}{4} \sin 2\theta_1 \left(2\mathbb{I}_{|\sin \theta_1| < |\cos \theta_1| - 1} \right) \\ &\quad + \frac{1}{2} \left(\text{sgn}(\tan \theta_1) \mathbb{I}_{|\sin \theta_1| < |\cos \theta_1|} \right. \\ &\quad \left. - \text{sgn}(\tan \theta_0) \mathbb{I}_{|\sin \theta_0| < |\cos \theta_0|} \right) \\ &\quad + \mathbb{I}_{\sin \theta_0 \sin \theta_1 > 0} \left(\text{sgn}(\theta_1 - \theta_0) \mathbb{I}_{\cos \theta_0 \cos \theta_1 > 0} \right. \\ &\quad \left. + \text{sgn}(\tan \theta_0) \mathbb{I}_{\cos \theta_0 \cos \theta_1 < 0} \right). \tag{37} \end{aligned}$$

End of the proof of Proposition 1 In order to prove Proposition 1, we suppose first that θ takes a value different from $(2k + 1)\frac{\pi}{4}$, for $k \in \mathbb{N}$. Since the curve γ admits a tangent at the point s , then for r small enough, (θ_0, θ_1) belongs to $[(2k + 1)\frac{\pi}{4}, (2k + 3)\frac{\pi}{4}] \times [(2k + 5)\frac{\pi}{4}, (2k + 7)\frac{\pi}{4}]$, for some $k \in \mathbb{N}$. We then deduce from (36) that,

- if $(\theta_0, \theta_1) \in [(2k + 1)\frac{\pi}{4}, (2k + 3)\frac{\pi}{4}] \times [(2k + 5)\frac{\pi}{4}, (2k + 7)\frac{\pi}{4}]$, with $k \in \{0, 2\}$, then

$$\lim_{\delta \rightarrow 0} \lim_{\varepsilon \rightarrow 0} \limsup_{N \rightarrow +\infty} \mathbf{A}_N^{\sigma, \gamma}(s, r, \delta) = \frac{1}{4} (\sin 2\theta_1 - \sin 2\theta_0).$$

- if $(\theta_0, \theta_1) \in [(2k + 1)\frac{\pi}{4}, (2k + 3)\frac{\pi}{4}] \times [(2k + 5)\frac{\pi}{4}, (2k + 7)\frac{\pi}{4}]$, with $k \in \{1, 3\}$, then

$$\lim_{\delta \rightarrow 0} \limsup_{N \rightarrow +\infty} \mathbf{A}_N^{\sigma, \gamma}(s, r, \delta) = \frac{1}{4} (\sin 2\theta_0 - \sin 2\theta_1).$$

We now need the following lemma.

Lemma 11 *Let γ be a Jordan curve of \mathbb{R}^2 of class \mathcal{C}_2 . Let s be a fixed point of γ . Let r be a positive real number sufficiently small such that $\partial B(s, r) \cap \gamma$ contains exactly two points x_0 and x_1 . Suppose that x_0, s and x_1 are arranged counterclockwise. Let s' be the common point to $T_{x_0}\gamma$ and $T_{x_1}\gamma$. Let $\theta_1 \in [0, 2\pi]$ (respectively $\theta_0 \in [0, 2\pi]$) be the oriented angle between the half horizontal axis $[0, +\infty[$ and the segment $[s', x_1[$ (respectively $[s', x_0[$). Then*

$$\lim_{r \rightarrow 0} \frac{\sin(\theta_0 - \theta_1)}{2r} = \xi_\gamma(s),$$

and

$$\lim_{r \rightarrow 0} \cos(\theta_0 + \theta_1) = -\cos 2\theta,$$

where θ is the angle between the half horizontal axis $[0, +\infty[$ and $T_s\gamma$.

Lemma 11, together with the two equalities just above Lemma 11 and the fact $\sin 2a - \sin 2b = 2 \sin(a - b) \cos(a + b)$, gives

$$\lim_{r \rightarrow 0} \lim_{\delta \rightarrow 0} \limsup_{N \rightarrow +\infty} \frac{1}{2r} \mathbf{A}_N^{\sigma, \gamma}(s, r, \delta) = \begin{cases} \frac{1}{2}(\cos 2\theta) \xi_\gamma(s) & \text{if } \theta \in](1 + 4k)\frac{\pi}{4}, (3 + 4k)\frac{\pi}{4}[\\ -\frac{1}{2}(\cos 2\theta) \xi_\gamma(s) & \text{if } \theta \in](3 + 4k)\frac{\pi}{4}, (5 + 4k)\frac{\pi}{4}[\end{cases}$$

which proves Theorem 1 when θ is different from $(2k + 1)\frac{\pi}{4}$, for $k \in \mathbb{N}$. Now, suppose that $\theta = \frac{\pi}{4}$ and that for any r small enough $(\theta_0, \theta_1) \in [\frac{\pi}{4}, 3\frac{\pi}{4}] \times [3\frac{\pi}{4}, 5\frac{\pi}{4}]$ (the arguments for the proof for the other values of θ and the corresponding values of θ_1, θ_0 will be similar). We have in that case,

$$\begin{aligned} \lim_{\delta \rightarrow 0} \limsup_{N \rightarrow +\infty} \mathbf{A}_N^{\sigma, \gamma}(s, r, \delta) &= \frac{1}{4} (2 - \sin 2\theta_1 - \sin 2\theta_0) \\ &= \frac{1}{2} \left(\sin \left(\frac{\pi}{4} - \theta_1 \right) \cos \left(\frac{\pi}{4} + \theta_1 \right) + \sin \left(\frac{\pi}{4} - \theta_0 \right) \right. \\ &\quad \left. \times \cos \left(\frac{\pi}{4} + \theta_0 \right) \right). \end{aligned} \tag{38}$$

Now the method of the proof of Lemma 11 gives

$$\lim_{r \rightarrow 0} \frac{\sin(\theta - \theta_1)}{r} = \lim_{r \rightarrow 0} \frac{\sin(\theta - \theta_0)}{r} = -\xi_\gamma(s).$$

This fact, together with (38), leads to

$$\lim_{r \rightarrow 0} \lim_{\delta \rightarrow 0} \limsup_{N \rightarrow +\infty} \frac{1}{r} \mathbf{A}_N^{\sigma, \gamma}(s, r, \delta) = 0,$$

which is the conclusion of Theorem 1 for $\theta = \frac{\pi}{4}$.

Proof of Lemma 11 We begin by giving the definition of the curvature of γ at any $s \in \gamma$.

Definition Let γ be a smooth Jordan curve of \mathbb{R}^2 . Suppose that $(\phi(t))_{t \in [-1, 1]}$ is a parametrization of the curve γ . Let $s = \phi(t) = (x(t), y(t))$ be a fixed point of γ . The curvature of γ at the point s is defined by

$$\xi_\gamma(s) = \frac{x'(t)y''(t) - x''(t)y'(t)}{(x'^2(t) + y'^2(t))^{3/2}}.$$

Let s, x_0 and x_1 be as defined in Lemma 11. Let t, t_0 and t_1 be three real numbers of $[-1, 1]$ such that $s = \phi(t) = (x(t), y(t))$, and for $i \in \{0, 1\}, x_i = \phi(t_i) = (x(t_i), y(t_i))$. We have $r^2 = (x(t_i) - x(t))^2 + (y(t_i) - y(t))^2$, for $i \in \{0, 1\}$. Hence

$$\lim_{t_0 \rightarrow t, t_0 < t} \frac{r}{t - t_0} = \sqrt{x'^2(t) + y'^2(t)}, \quad \lim_{t_1 \rightarrow t, t < t_1} \frac{r}{t_1 - t} = \sqrt{x'^2(t) + y'^2(t)}.$$

For any $\tau \in [-1, 1]$, define $f(\tau) = \frac{x'(\tau)}{\sqrt{x'^2(\tau) + y'^2(\tau)}}$. We have

$$f'(\tau) = \frac{x''(\tau)}{\sqrt{x'^2(\tau) + y'^2(\tau)}} - x'(\tau) \frac{x'(\tau)x''(\tau) + y'(\tau)y''(\tau)}{(x'^2(\tau) + y'^2(\tau))^{3/2}}.$$

Hence

$$\begin{aligned} \cos \theta_0 &= -\frac{x'(t_0)}{\sqrt{x'^2(t_0) + y'^2(t_0)}} \\ &= -\frac{x'(t)}{\sqrt{x'^2(t) + y'^2(t)}} + (t - t_0)f'(t) + o(|t - t_0|). \end{aligned} \tag{39}$$

$$\cos \theta_1 = \frac{x'(t)}{\sqrt{x'^2(t) + y'^2(t)}} + (t_1 - t)f'(t) + o(|t_1 - t|). \tag{40}$$

We obtain, combining the last two equalities

$$\lim_{t_1 \rightarrow t, t_0 \rightarrow t, t_0 < t < t_1} \frac{\cos \theta_0 + \cos \theta_1}{r} = \frac{2x''(t)}{x'^2(t) + y'^2(t)} - 2x'(t) \frac{x'(t)x''(t) + y'(t)y''(t)}{(x'^2(t) + y'^2(t))^2}.$$

The last limit together with

$$\lim_{t_1 \rightarrow t, t < t_1} \sin \theta_1 = \frac{y'(t)}{\sqrt{x'^2(t) + y'^2(t)}},$$

ensures

$$\begin{aligned} & \lim_{t_1 \rightarrow t, t_0 \rightarrow t, t_0 < t < t_1} \frac{1}{r} \sin \theta_1 (\cos \theta_0 + \cos \theta_1) \\ &= \frac{2x''(t)y'(t)}{(x'^2(t) + y'^2(t))^{3/2}} - 2x'(t)y'(t) \frac{x'(t)x''(t) + y'(t)y''(t)}{(x'^2(t) + y'^2(t))^{5/2}}. \end{aligned}$$

In the same way, we prove that

$$\begin{aligned} & \lim_{t_1 \rightarrow t, t_0 \rightarrow t, t_0 < t < t_1} \frac{1}{r} \cos \theta_1 (\sin \theta_0 + \sin \theta_1) \\ &= \frac{2x'(t)y''(t)}{(x'^2(t) + y'^2(t))^{3/2}} - 2x'(t)y'(t) \frac{x'(t)x''(t) + y'(t)y''(t)}{(x'^2(t) + y'^2(t))^{5/2}}. \end{aligned}$$

The last two limits together with

$$\sin(\theta_0 - \theta_1) = \cos \theta_1 (\sin \theta_1 + \sin \theta_0) - \sin \theta_1 (\cos \theta_0 + \cos \theta_1),$$

prove that

$$\lim_{t_1 \rightarrow t, t_0 \rightarrow t, t_0 < t < t_1} \frac{1}{2r} \sin(\theta_0 - \theta_1) = \frac{x'(t)y''(t) - x''(t)y'(t)}{(x'^2(t) + y'^2(t))^{3/2}}.$$

Now the equality

$$\cos(\theta_0 + \theta_1) = \cos \theta_0 \cos \theta_1 - \sin \theta_0 \sin \theta_1,$$

together with the limits (39), (40), yields

$$\lim_{t_1 \rightarrow t, t_0 \rightarrow t, t_0 < t < t_1} \cos(\theta_0 + \theta_1) = \frac{y'^2(t) - x'^2(t)}{x'^2(t) + y'^2(t)}.$$

The last limit is equal to $-\cos 2\theta$, where θ is the angle between the horizontal axis and $T_S \gamma$. □

5.6 Proof of Proposition 2

Our purpose is to apply Theorem 2. So we have to check, the requirements of Theorem 2. We first prove the condition (3). We claim that, for all $\varepsilon > 0$,

$$\lim_{N \rightarrow \infty} \mu_N (\sup |\Phi_N(x_N) - f(x_N)| \geq \varepsilon) = 0, \tag{41}$$

where the supremum is taken over $x_N \in [a, b] \cap \frac{\mathbb{Z}}{N}$.

Proof of (41) For $l \in \mathbb{Z}$, we denote by $\eta(\frac{l}{N})$ the height difference $\eta(\frac{l}{N}) = \Phi_N(\frac{l+1}{N}) - \Phi_N(\frac{l}{N})$. Without loss of generality, we will take $a = 0$. We write, for $\frac{k}{N} \in [0, b] \cap \frac{\mathbb{Z}}{N}$,

$$\Phi_N\left(\frac{k}{N}\right) - f\left(\frac{k}{N}\right) = \sum_{l=0}^{k-1} \left(\eta\left(\frac{l}{N}\right) - \left(f\left(\frac{l+1}{N}\right) - f\left(\frac{l}{N}\right) \right) \right) + (\Phi_N(0) - f(0)).$$

The last equality gives, since $\mu_N\left(\eta\left(\frac{k}{N}\right)\right) = \frac{1}{N}|f'| \left(\frac{k}{N}\right)$,

$$\begin{aligned} & \Phi_N\left(\frac{k}{N}\right) - f\left(\frac{k}{N}\right) \\ &= \sum_{l=0}^{k-1} \left(\eta\left(\frac{l}{N}\right) - \mu_N\left(\eta\left(\frac{l}{N}\right)\right) \right) \\ & \quad - \sum_{l=0}^{k-1} \left(\left(f\left(\frac{l+1}{N}\right) - f\left(\frac{l}{N}\right) \right) - \frac{1}{N}|f'| \left(\frac{l}{N}\right) \right) + (\Phi_N(0) - f(0)). \end{aligned}$$

We deduce from the last equality, assumption (2) of Proposition 2 and the fact

$$\sum_{l=0}^{k-1} \left| f\left(\frac{l+1}{N}\right) - f\left(\frac{l}{N}\right) - \frac{1}{N}|f'| \left(\frac{l}{N}\right) \right| \leq \frac{b}{N} \|f''\|_\infty,$$

that (41) is proved as soon as,

$$\lim_{N \rightarrow \infty} \mu_N \left(\sup_{0 \leq k \leq Nb} \left| \sum_{l=0}^{k-1} \left(\eta\left(\frac{l}{N}\right) - \mu_N\left(\eta\left(\frac{l}{N}\right)\right) \right) \right| \geq \varepsilon \right) = 0. \tag{42}$$

For this, we use a Markov inequality, the independence of the random variables $(\eta(\frac{l}{N}))_{l \in \mathbb{Z}}$ and a Rosenthal inequality (cf. Sect. 2.6.19 and Theorem 2.9 of

Petrov (1995)). We get, for an universal constant C ,

$$\begin{aligned} &\mu_N \left(\sup_{0 \leq k \leq Nb} \left| \sum_{l=0}^{k-1} \left(\eta \left(\frac{l}{N} \right) - \mu_N \left(\eta \left(\frac{l}{N} \right) \right) \right) \right| \geq \varepsilon \right) \\ &\leq \frac{1}{\varepsilon^3} \mu_N \left(\sup_{0 \leq k \leq Nb} \left| \sum_{l=0}^{k-1} \left(\eta \left(\frac{l}{N} \right) - \mu_N \left(\eta \left(\frac{l}{N} \right) \right) \right) \right|^3 \right) \\ &\leq \frac{C}{\varepsilon^3} \left\{ \left(\sum_{l=0}^{Nb} \text{Var}_{\mu_N} \left(\eta \left(\frac{l}{N} \right) \right) \right)^{3/2} + \sum_{l=0}^{Nb} \mu_N \left(\left| \eta \left(\frac{l}{N} \right) - \mu_N \left(\eta \left(\frac{l}{N} \right) \right) \right|^3 \right) \right\}. \end{aligned}$$

The last estimations and the fact that, for some constant C depending on $\|f'\|_\infty$,

$$\text{Var}_{\mu_N} \eta \left(\frac{l}{N} \right) = \frac{1}{N^2} |f'| \left(\frac{l}{N} \right) \left(1 + |f'| \left(\frac{l}{N} \right) \right)^2, \quad \mu_N \left(\left| \eta \left(\frac{l}{N} \right) \right|^3 \right) \leq C \frac{1}{N^3}$$

give

$$\mu_N \left(\sup_{0 \leq k \leq Nb} \left| \sum_{l=0}^{k-1} \left(\eta \left(\frac{l}{N} \right) - \mu_N \left(\eta \left(\frac{l}{N} \right) \right) \right) \right| \geq \varepsilon \right) = \mathcal{O} \left(\left(\frac{1}{N} \right)^{3/2} \right),$$

which proves (42) and then (41). Now (41) allows to deduce the condition (3).

We deduce from the definition of μ_N , that for any $N \in \mathbb{N}^*$

$$\forall k \in [Na, Nb] \cap \mathbb{Z} \quad \mu_N \left(\text{sgn} \left(\eta \left(\frac{k}{N} \right) f' \left(\frac{k}{N} \right) \right) < 0 \right) = 0.$$

Since the graph of the monotone function f coincides with the restriction of γ over $[a, b]$, we conclude from the above formula that $\partial A_\sigma^N \cap \mathcal{S}(s, r, \delta, \delta)$ and $\gamma \cap \mathcal{S}(s, r, \delta, \delta)$ are both nondecreasing or both nonincreasing.

Our task now is to check the condition (6) and to precise the value of the corresponding function C . Recall that f and Φ_N are both increasing or decreasing. Therefore

$$C_N(x_0, \delta) = \sum_{x_0 \cdot i \leq k/N \leq \delta | \cos \theta_0 | + x_0 \cdot i} \mathbb{I}_{\eta \left(\frac{k}{N} \right) \neq 0},$$

where the quantity $C_N(x_0, \delta)$ is defined just before Theorem 1. We have

$$\begin{aligned} \frac{1}{N\delta} \mu_N (C_N(x_0, \delta)) &= \frac{1}{N\delta} \sum_{x_0 \cdot i \leq k/N \leq \delta | \cos \theta_0 | + x_0 \cdot i} \mu_N \left(\eta \left(\frac{k}{N} \right) \neq 0 \right) \\ &= \frac{1}{N\delta} \sum_{x_0 \cdot i \leq k/N \leq \delta | \cos \theta_0 | + x_0 \cdot i} \frac{|f'| \left(\frac{k}{N} \right)}{1 + |f'| \left(\frac{k}{N} \right)}. \end{aligned}$$

The last equality gives

$$\lim_{N \rightarrow \infty} \frac{1}{N\delta} \mu_N (C_N(x_0, \delta)) = \frac{1}{\delta} \int_{x_0 \cdot i}^{\delta | \cos \theta_0 | + x_0 \cdot i} \frac{|f'(x)|}{1 + |f'(x)|} dx.$$

Hence

$$\begin{aligned} \lim_{\delta \rightarrow 0} \lim_{N \rightarrow \infty} \frac{1}{N\delta} \mu_N (C_N(x_0, \delta)) &= | \cos \theta_0 | \frac{|f'(x_0 \cdot i)|}{1 + |f'(x_0 \cdot i)|} = | \cos \theta_0 | \frac{| \tan \theta_0 |}{1 + | \tan \theta_0 |} \\ &= \frac{| \sin (2\theta_0) |}{2(| \sin \theta_0 | + | \cos \theta_0 |)} = C(\theta_0). \end{aligned}$$

We have assumed in Proposition 2 that the curve γ is monotone in $B(s, r) \cup B(x_0, \delta) \cup B(x_1, \delta)$. This fact allows to deduce that,

$$\sin \theta_0 \sin \theta_1 \leq 0, \quad \cos \theta_0 \cos \theta_1 \leq 0.$$

We use the last constatation together with the conclusion of Theorem 2 to obtain,

$$\begin{aligned} \lim_{\delta \rightarrow 0} \limsup_{N \rightarrow \infty} \mu_N (\mathbf{A}_N^{\sigma, \gamma}(s, r, \delta)) &= \lim_{\delta \rightarrow 0} \liminf_{N \rightarrow \infty} \mu_N (\mathbf{A}_N^{\sigma, \gamma}(s, r, \delta)) \tag{43} \\ &= \frac{1}{2} \operatorname{sgn}(\tan \theta_0) \left(\cos^2 \theta_1 - \cos^2 \theta_0 \right) \\ &\quad + \frac{1}{2} \operatorname{sgn}(\tan \theta_0) \left(\frac{| \sin (2\theta_1) |}{2(| \sin \theta_1 | + | \cos \theta_1 |)} (| \sin \theta_1 | - | \cos \theta_1 |) \right. \\ &\quad \left. - \frac{| \sin (2\theta_0) |}{2(| \sin \theta_0 | + | \cos \theta_0 |)} (| \sin \theta_0 | - | \cos \theta_0 |) \right). \end{aligned}$$

We have

$$\begin{aligned} & \operatorname{sgn}(\tan \theta_0) \left(\frac{|\sin (2\theta_1)|}{2(|\sin \theta_1|+|\cos \theta_1|)} (|\sin \theta_1|-|\cos \theta_1|) \right. \\ & \quad \left. - \frac{|\sin (2\theta_0)|}{2(|\sin \theta_0|+|\cos \theta_0|)} (|\sin \theta_0|-|\cos \theta_0|) \right) \\ &= \frac{\sin \theta_1 \cos \theta_1}{(|\sin \theta_1|+|\cos \theta_1|)} (|\sin \theta_1|-|\cos \theta_1|) - \frac{\sin \theta_0 \cos \theta_0}{(|\sin \theta_0|+|\cos \theta_0|)} \\ & \quad \times (|\sin \theta_0|-|\cos \theta_0|) = \frac{-\sin (\theta_0-\theta_1)}{(|\sin \theta_1|+|\cos \theta_1|)(|\sin \theta_0|+|\cos \theta_0|)} \\ & \quad + \frac{(\cos ^2 \theta_1-\cos ^2 \theta_0)(\sin \theta_0 \cos \theta_1+\sin \theta_1 \cos \theta_0+\cos \theta_0 \cos \theta_1 \operatorname{sgn}(\tan \theta_0)+\sin \theta_0 \sin \theta_1 \operatorname{sgn}(\tan \theta_0))}{(|\sin \theta_1|+|\cos \theta_1|)(|\sin \theta_0|+|\cos \theta_0|)} \\ &= \frac{-\sin (\theta_0-\theta_1)}{(|\sin \theta_1|+|\cos \theta_1|)(|\sin \theta_0|+|\cos \theta_0|)} - \operatorname{sgn}(\tan \theta_0)(\cos ^2 \theta_1-\cos ^2 \theta_0). \end{aligned}$$

We conclude from (43) together with the last equalities,

$$\begin{aligned} \lim _{\delta \rightarrow 0} \limsup _{N \rightarrow \infty} \mu_N\left(\mathbf{A}_N^{\sigma, \gamma}(s, r, \delta)\right) &= \lim _{\delta \rightarrow 0} \liminf _{N \rightarrow \infty} \mu_N\left(\mathbf{A}_N^{\sigma, \gamma}(s, r, \delta)\right) \\ &= \frac{-\sin (\theta_0-\theta_1)}{2(|\sin \theta_1|+|\cos \theta_1|)(|\sin \theta_0|+|\cos \theta_0|)}. \end{aligned}$$

The last limit together with Lemma 11 completes the proof of Proposition 2. \square

Acknowledgements The authors wish to thank Patrice Assouad and Sophie Lemaire for useful discussions. The first version of this work dealt only with the deterministic initial condition; we are very grateful to Herbert Spohn for explaining to us the relevance of the randomness in the initial condition.

References

1. Andjel, E.D.: Invariant measures for the zero range process. *Ann. Probab.* **10**(3), 525–547 (1982)
2. Chayes, L., Swindle, G.: Hydrodynamic limits for one-dimensional particle systems with moving boundaries. *Ann. Probab.* **24**(2), 559–598 (1996)
3. Chayes, L., Schonmann, R.H., Swindle, G.: Lifshitz’ law for the volume of a two-dimensional droplet at zero temperature. *J. Stat. Phys.* **79**(5–6), 821–831 (1995)
4. De Masi, A., Orlandi, E., Presutti, E., Triolo, L.: Motion by curvature by scaling nonlocal evolution equations. *J. Stat. Phys.* **73**(3–4), 543–570 (1993)
5. De Masi, A., Orlandi, E., Presutti, E., Triolo, L.: Glauber evolution with the Kac potentials. I. Mesoscopic and macroscopic limits, interface dynamics. *Nonlinearity* **7**(3), 633–696 (1994)
6. Katsoulakis, M.A., Souganidis, P.E.: Generalized motion by mean curvature as a macroscopic limit of stochastic Ising models with long range interactions and Glauber dynamics. *Commun. Math. Phys.* **169**(1), 61–97 (1995)

7. Katsoulakis, M.A., Souganidis, P.E.: Stochastic Ising models and anisotropic front propagation. *J. Stat. Phys.* **87**(1–2), 63–89 (1997)
8. Petrov, V.V.: Limit theorems of probability theory: sequences of independent random variables. Clarendon Press, Oxford (1995)
9. Sowers, R.B.: Hydrodynamical limits and geometric measure theory: mean curvature limits from a threshold voter model. *J. Funct. Anal.* **169**(2), 421–455 (1999)
10. Spohn, H.: Interface motion in models with stochastic dynamics. *J. Stat. Phys.* **71**(5–6), 1081–1132 (1993)