

Strain-related physiological and behavioral effects of *Skeletonema marinoi* on three common planktonic copepods

Roswati Md Amin · Marja Koski · Ulf Båmstedt · Charles Vidoudez

Received: 9 February 2011 / Accepted: 16 April 2011 / Published online: 6 May 2011
© The Author(s) 2011. This article is published with open access at Springerlink.com

Abstract Three strains of the chain-forming diatom *Skeletonema marinoi*, differing in their production of polyunsaturated aldehydes (PUA) and nutritional food components, were used in experiments on feeding, egg production, hatching success, pellet production, and behavior of three common planktonic copepods: *Acartia tonsa*, *Pseudocalanus elongatus*, and *Temora longicornis*. The three different diatom strains (9B, 1G, and 7J) induced widely different effects on *Acartia tonsa* physiology, and the 9B strain induced different effects for the three copepods. In contrast, different strains induced no or small alterations in the distribution, swimming behavior, and turning frequency of the copepods. 22:6(n-3) fatty acid (DHA) and sterol content of the diet typically showed a

positive effect on either egg production (*A. tonsa*) or hatching success (*P. elongatus*), while other measured compounds (PUA, other long-chain polyunsaturated fatty acids) of the algae had no obvious effects. Our results demonstrate that differences between strains of a given diatom species can generate effects on copepod physiology, which are as large as those induced by different algae species or groups. This emphasizes the need to identify the specific characteristics of local diatoms together with the interacting effects of different mineral, biochemical, and toxic compounds and their potential implications on different copepod species.

Communicated by X. Irigoien.

R. Md Amin (✉) · U. Båmstedt
Umeå Marine Sciences Centre, Umeå University,
Norrbyn, 91020 Hörnefors, Sweden
e-mail: roswati.mdamin@emg.umu.se;
roswati_ma@umt.edu.my

R. Md Amin · U. Båmstedt
Department of Ecology and Environmental Sciences,
Umeå University, 90187 Umeå, Sweden

R. Md Amin
Department of Marine Science, Faculty of Maritime Studies
and Marine Science, Universiti Malaysia Terengganu,
21030 Kuala, Terengganu, Malaysia

M. Koski
National Institute of Aquatic Resources, Technical University
of Denmark, Kavalergården 6, 2920 Charlottenlund, Denmark

C. Vidoudez
Department of organismic and evolutionary biology, Harvard
University, 16 Divinity Ave, Cambridge, MA 02138, USA

Introduction

Negative effects of harmful phytoplankton on grazers, ranging from feeding inhibition and physiological incapacitation to reduction in egg production and egg hatching rates, are common (see Turner et al. 2001 and references therein). Traditionally, diatoms have been considered as a basis for a short and effective food chain leading to a high fish production (Steele 1974); a view which is confirmed in a number of more recent field studies (Irigoien et al. 2002 and references therein). During the last 15 years, however, this view has been challenged by studies showing reduced copepod hatching success and/or egg production on diatom-dominated diets (e.g., Miralto et al. 1999; Dutz et al. 2008). Several mechanisms have been suggested to cause these negative effects. Firstly, inhibitory chemical compounds, identified as polyunsaturated aldehydes (PUA), have been shown to block embryogenesis in copepods and sea urchins and have antiproliferative and apoptotic effects on human carcinoma cells (Miralto et al. 1999). These compounds have been detected in many diatoms (Miralto

et al. 1999; Wichard et al. 2007), including several strains of the *Skeletonema marinoi* (recently separated from *Skeletonema costatum*, Sarno et al. 2005), which is a common spring bloom diatom in the Baltic Sea, particularly in eutrophic areas (Ask et al. 2006). Secondly, nutritional inadequacy of diatoms, such as fatty acid or sterol, have also been observed to induce low production rate and hatching success of copepod eggs (Jónasdóttir 1994; Jónasdóttir et al. 2009). Recent findings have added possible explanations for the negative effects of diatoms, such as a rapid depletion of polyunsaturated fatty acids (especially eicosapentaenoic acid EPA) caused by the PUA production upon mechanical wounding (Wichard et al. 2007), a compound inducing oxidative stress (Fontana et al. 2007a, b), and a low assimilation efficiency of essential compound with a shorter residence time in copepod guts (Dutz et al. 2008). Still, the exact mechanisms remain unknown with numerous inconsistencies in the results from different investigations.

Typically, the effect of diatoms on the feeding or reproduction of copepods can vary greatly among species and is situation specific, due to differences in the species and genetic composition of the bloom (see Turner and Tester 1989; Rynearson et al. 2006) or differences in nutritional requirements of the copepod (Hasset 2004). Variation in inhibitory effects of diatoms does also occur at the intraspecific strain level (Ask et al. 2006; Koski et al. 2008; Dutz et al. 2008). For instance, different strains of *Thalassiosira rotula* have been observed to have both positive and negative effects on copepods development (Koski et al. 2008) and different strains of *Skeletonema costatum* induced variable hatching success of *Eurytemora affinis* (Ask et al. 2006). Further, *S. marinoi* in culture has also been observed to release pronounced bursts of PUAs (heptadienal and octadienal) that are strongly dependent on the growth phase (Vidoudez and Pohnert 2008). Recently, Taylor et al. (2009) isolated nine different strains of *S. marinoi* in the Gullmar Fjord, Skagerrak and reported large differences in the PUA production between seasons. The clones isolated showed different physiological responses and degree of genetic heterogeneity indicating that different populations succeed each other in the fjord (Saravanan and Godhe 2010). These observations indicate that there can be differences in the toxic and biochemical properties of diatoms depending on strains, genetic variability, growth stage of the algae, and season.

In nature, phytoplankton cells are patchily distributed (Daro 1988) over a distance of a few centimeters to meters (Leising and Franks 2000). To maximize exposure to limiting resources, copepods need to be able to find and remain within the patches of high food concentration (Dagg 1977; Tiselius 1992). There is increasing evidence that copepods have some ability to respond quickly and

locate the high resource patch (Buskey 1984; Tiselius and Jonsson 1990; Tiselius 1992). Some copepod species are believed to decrease their swimming speed or jump frequency when encountering a patch of high food concentration (*Acartia tonsa*, Tiselius 1992; *Temora longicornis*, and *Pseudocalanus elongatus*, Tiselius and Jonsson 1990) suggesting that they may be using some type of “area-restricted search” behavior (Leising 2002). Studies on behavioral adaptation of zooplankton aggregation and swimming when the food patches consist of a potentially toxic or harmful algae are rare. However, by analyzing the behavioral response of copepods to a high concentration of toxic *Karenia brevis*, Cohen et al. (2007) showed that *Temora turbinata* actively avoided dense patches of this species. Pierson et al. (2005) found a similar pattern with *Calanus pacificus* females, which strongly avoided the layer with a high diatom concentration, which was suggested to result in a high reproductive success.

Motivation of this study was to investigate the strain- and species-specific effect of *S. marinoi* on copepod physiology and behavior, in relation to both nutritional quality and toxicity of the algae. Specifically, we investigated the strain-specific effect of *S. marinoi* on feeding, egg production, and hatching of three common planktonic calanoid copepods, *A. tonsa*, *P. elongatus*, and *T. longicornis*. We analyzed copepod behavior in order to see whether copepods alter their distribution and swimming behavior as a response to different biochemical properties and PUA content of the alga. Our results bring new detailed information on copepod–diatom interactions in the level of species and strains, as well as provide one of the few existing data sets where both algae nutritional and toxic compounds, as well as copepods ingestion of these, are measured.

Materials and methods

Algae and copepods

We used three copepod species and three *Skeletonema marinoi* strains, as well as *Rhodomonas* sp., which served as a good quality control food. All algae were offered to the copepods as a single food source, at a concentration of ca. $200 \mu\text{g C l}^{-1}$. All three copepod species, *Acartia tonsa*, *Temora longicornis*, and *Pseudocalanus elongatus*, were tested with a chain forming *S. marinoi* strain GF04-9B (9B; $264 \mu\text{m}^3$ cell volume) and *Rhodomonas* sp. (RHO) in all experiments. *A. tonsa* was additionally tested with two other *S. marinoi* strains, GF04-1G (1G; $622 \mu\text{m}^3$) and GF04-7J (7J; $141 \mu\text{m}^3$; Table 1).

All strains originated from the culture collection of the University of Gothenburg, Sweden and were isolated at

Table 1 Strain number, volume (μm^3), carbon and nitrogen content (pg cell^{-1}), C/N ratio (weight), and content of 20:5(n-3) fatty acid (EPA), 22:6 (n-3) fatty acid (DHA), total (tFA) and polyunsaturated fatty acid (16–22 PUFA) ($\text{fg } \mu\text{m}^{-3}$), sterol $\Delta 5$ ($\text{fg } \mu\text{m}^{-3}$), cholesterol ($\text{fg } \mu\text{m}^{-3}$) and total PUA (fmol cell^{-1}) in *Rhodomonas* sp., and the three *Skeletonema marinoi* strains

Algae	Strain	Vol	Cells per chain	C	N	C/N	EPA	DHA	EPA/DHA	Sterols	Cholest.	tFA	PUFA	Total PUA
<i>Rhodomonas</i> sp.		152		58	11.9	4.87	1.97	1.97	1.00	2.168	0	8.895	6.8	0
<i>S. marinoi</i>	GF04-9B	264	1–4	18.3	3.32	5.51	1.01	0.1	10.60	0.034	0.0083	2.745	1.97	0.32
<i>S. marinoi</i>	GF04-7J	141	3–5	10	1.93	5.18	6.34	9.98	0.64	0.124	0.1241	43.25	19	0.0022
<i>S. marinoi</i>	GF04-1G	622	1–2	48	7.58	6.33	1.06	0.17	6.42	0.009	0	3.543	2.08	0

Lipid content of *Rhodomonas* sp. diet was estimated based on volume-specific content in Dutz et al. (2008)

Blank no data

different times of the year 2004 (1G; February, 7J; June and 9B, September; Saravanan and Godhe 2010). All strains have been verified to belong to the same species although the genetic heterogeneity was high and physiological responses different (e.g., growth rate, biovolumes) depending on season, temperature, and salinity. All strains were also observed to produce different ranges of PUA after several months of cultivation under identical conditions, with the highest PUA production in 1G (ca. 0.7 fmol cell^{-1}), second highest in 9B (ca. 0.3 fmol cell^{-1}), and lowest in 7J (ca. 0.2 fmol cell^{-1} , Taylor et al. 2009) suggesting that the differences are not due to the experimental set of conditions. At the time of the present study, the PUA production was, however, changed (Table 1). It is thus unknown to which degree the strains reflected their original properties or genetic composition after several years of cultivation, but the differences observed in PUA production, biochemical composition, and morphology still suggested a high variability in a number of important properties.

Copepods were cultured in the laboratory at 15°C, in a salinity of ~35‰ in the dark, with a mixture of food consisting of *Rhodomonas* sp., *Thalassiosira weissflogii*, and *Heterocapsa* sp., offered at a saturating concentration of $>400 \mu\text{g C l}^{-1}$ (Koski et al. 2006). When adults occurred, both females and males were sorted out, and ca. 60 actively swimming individuals (depending on species) were isolated under dissecting microscope. The individual carbon content of copepods was estimated from the measured length and the length–dry weight relationship by Klein Breteler et al. (1982) for *T. longicornis* and *P. elongatus* and Kiørboe et al. (1985) for *A. tonsa*. The estimated individual carbon content was 3.30 $\mu\text{g C}$ for *A. tonsa*, 5.67 $\mu\text{g C}$ for *T. longicornis*, and 8.15 $\mu\text{g C}$ for *P. elongatus*.

All algae were grown under identical conditions in batches of 1–2 l with F/2 + Si medium at 18°C with a light/dark cycle of 14:10 h. Algae were kept in exponential growth phase by diluting the culture every ca. 3 days. The algae volume was determined either by using a Coulter counter (RHO and 1G) or an inverted microscope (9B and

7J), by measuring ca. 30 cells (Zeiss Axiovert S100, 400× magnification) and using an appropriate geometric formula for the volume determination. As 1G strain always consisted of single cells (Table 1), it was appropriate to use an electronic particle counter to determine its abundance. During the experiments, mean carbon content per cell was estimated from the volume, assuming an average carbon content of 0.077 $\text{pg } \mu\text{m}^{-3}$ as measured earlier for *Skeletonema costatum* (Dutz et al. 2008; Koski et al. 2008). Later, ca. 20 ml of the algae cultures were filtered on duplicate precombusted (6-h at 450°C) Whatman GF/F filters for the analysis of particulate organic carbon and nitrogen with a Carlo Erba elemental analyzer, using standard procedures and a combustion temperature of 1,030°C (Ask et al. 2006).

Similarly, a defined volume (80–100 mL) of each algae culture was filtered for the quantification of PUA and lipid. PUA were analyzed according to Vidoudez et al. (2011). In short, cells were transferred in a buffer containing 25 mM O-(2,3,4,5,6-pentafluorobenzyl) hydroxylamine hydrochloride (PFBHA, derivatization grade >99%, Sigma–Aldrich) prior disruption by sonication to trigger the production of the PUA. The derivatized PUA were then extracted with hexane and analyzed by using a gas chromatography–mass spectrometer (GC–MS). Fatty acids and sterols were analyzed according to Jónasdóttir et al. 2011). In short, cell fatty acids were transesterified in methanol/acetyl chloride 9:1 (>99.0%, Sigma–Aldrich) before extraction with hexane. The same samples were then extracted twice with chloroform to recover the sterols. Chloroform and hexane phases were combined and, after silylation with N-nethyl-N-(trimethylsilyl) trifluoroacetamide (Macherey–Nagel, Düren, Germany), were analyzed by GC–MS. Sterols are presented as the total concentration of three identified $\Delta 5$ sterols, cholesterol, brassicasterol, and campesterol. Total concentration of polyunsaturated fatty acids (PUFA) represents the sum of the identified 16–22 fatty acids. The mineral and biochemical properties of algae were measured once in the course of the 8-day experiments.

Grazing and egg production

The experiments were carried out for 8 or 10 days, with daily measurements of egg production and hatching, and two separate 24-h experiments to determine pellet production and ingestion rates (days 3–4 and 7–9). For *A. tonsa* feeding on 7J, the incubation was ended at day 5 due to high mortality rate (see result). Experiments were conducted with 4–5 experimental replicates, and 2–3 controls without copepods were added for grazing experiments. Food suspension was renewed daily. Depending on the species, 8–15 copepods, including 1–2 males, were incubated in 625 ml bottles containing the appropriate food suspension. The bottles were carefully closed to prevent any air bubbles and kept in suspension by rotating at 1 rpm at 15°C.

Every 24-h (*A. tonsa* and *T. longicornis*) or 48-h (*P. elongatus*) interval, contents of the bottles were gently poured onto a 180 µm (copepods) and 50 µm (eggs) mesh sieve, the number of copepods and eggs were counted, the condition of copepods checked, and dead copepods were removed. The difference in incubation time resulted from the absence of egg sacs for all *P. elongatus* female at the beginning of the experiment and production of a new egg sac was assumed to take >24 h (Koski et al. 2006). However, to be sure of not including any bias due to incubation time, we also calculated the egg production of *P. elongatus* based on the egg ratio method (Runge and Roff 2000), which gave similar rates. Empty egg shells were counted and included in the calculations of egg production to account for cannibalized eggs. However, they rarely contributed for more than 2% of the total egg number. The produced eggs were flushed into 330 ml bottles in filtered sea water, and the hatching success was determined after another 3 days of incubation, by counting the remaining eggs and nauplii. At the end of the experiment, copepods were preserved for length measurements, which were later conducted using a stereo microscope (Leica MZ6, 20× magnifications).

For grazing experiments, cell concentrations at the start and end of the incubations were counted from subsamples preserved with Lugol's iodine solution, using an inverted microscope (>400 cell sample⁻¹; 7J and 9B) or a Coulter counter (MultisizerTM 3; RHO and *Skeletonema marinoi* 1G). From our observation, 1G strain always consisted of single cells with a few 2 cell chains. To ensure that the chain length did not change due to the presence of copepods, additional control experiment were performed to compare the microscopic cell counts with the Coulter counter counts, in the absence and presence of copepods. The cell numbers counted with both methods were comparable, and the differences were not influenced by the number of copepods present in the incubations (data not

shown). Ingestion and clearance rates were estimated using the method of Frost (1972). For pellet volume, ca. 30 pellets per treatment were measured using a stereo microscope (Leica MZ6, 40× magnifications), assuming a cylinder shape.

Carbon-specific egg production was calculated by multiplying egg production by the egg carbon mass (µg C) and dividing by the female body mass (µg C). Carbon content of *T. longicornis* and *P. elongatus* eggs were estimated to be ca. 0.09 and 0.19 µg C egg⁻¹, respectively (Koski et al. 2006), while *A. tonsa* eggs were estimated to be 0.046 µg C egg⁻¹ (Kiørboe et al. 1985). The efficiency of egg production was calculated from the ratio of egg produced to the ingested food carbon.

When *Temora longicornis* was feeding on RHO, we observed a clear discrepancy with previous results (Dutz et al. 2008), with negligible egg and pellet production and hatching success (see results). As the simultaneously measured maximum egg production with the 9B strain of *Skeletonema* (days 7–8) was relatively high, we interpreted this low reproduction to be due to some unexplained problem with the RHO culture at the time of this incubation, and not related to the condition of *T. longicornis* (such as age, past-feeding history, or fertilization limitation). When a comparison with RHO was necessary (e.g., egg production, hatching, and egg production efficiency), we used previous measurements done in the same culture of *T. longicornis* and RHO, under similar conditions (Dutz et al. 2008). The egg production and hatching rates of *T. longicornis* on 9B should, however, be considered as conservative minimum rates.

Behavioral changes

Copepods behavioral response to different *Skeletonema marinoi* strains was studied as described in Tiselius (1992), by creating a patchy food distribution. In these experiments, we compared behavioral responses (percentage distribution, swimming speed, and turning angle in the food patch) of all three copepod species with food (9B) and without food (filtered seawater; FSW), with *A. tonsa* additionally tested with 1G and 7J. We used both fed and 24-h starved individuals to account for the possible effects of a hunger response. The patchy food distribution was created by using a salinity gradient, where the upper (32‰) and bottom (36‰) part of the aquarium contained filtered seawater, and food at a concentration of ca. 200 µg C l⁻¹ was added in the middle (34‰) part of the 0.5 l aquarium (20 × 5 × 5 cm). The patch in the middle of the aquarium was made by gently siphoning through a modified tube positioned at the bottom of the aquarium by starting with the lightest water (Fig. 1). To the food patch was added a few drops of food color, to recognize the food layer.

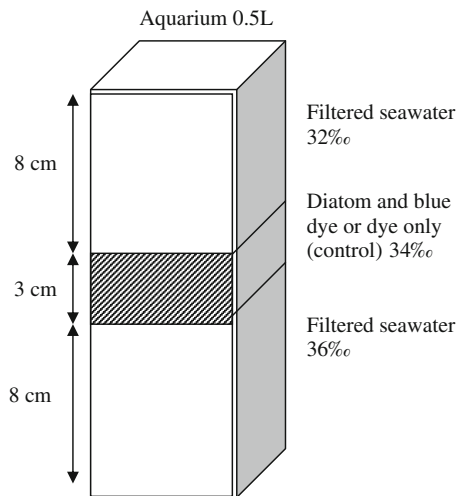

Fig. 1 Schematic figure of aquarium used in the behavior experiment

To check for the effect of salinity gradient and food dye, control aquariums were created similarly, but excluding the algae from the middle layer. As all copepods were coastal species and have a wide salinity tolerance (see e.g., Holste et al. 2009; Renz and Hirche 2006), the steep gradient used in this study was considered acceptable.

Prior to the experiment, adult female copepods were kept in 2 l containers with RHO at a concentration of ca. $300 \mu\text{g C l}^{-1}$ (fed experiments) or without food (starved experiments) at 15°C for 24 h. At the start of the experiments, 20 copepods of each species were carefully introduced to the top of the aquarium with a pipette and filmed as they sank to the food layer. Observations were made over a 2-h period approximately the same time of the day, between 14:00 and 18:00. Both the experiment (middle layer with food) and control (middle layer without food) were run during the same day.

For filming, we used a 2D setup with Panasonic CCD-F10 camera equipped with a 35 mm lens, connected to a synchronizer, a mixer, a time–date generator (Panasonic WJ180), and a video cassette recorder, VCR (Panasonic NV-FS200 HQ). The aquarium was illuminated from the back by collimated light, the only light source for filming. Two-dimensional projection of swimming tracks were digitized using LABTRACK (Bioras, Kvistgard, Denmark) (Kiørboe 2007). The program allows setting of thresholds for size, minimum track length, minimum velocity, and contrast, ensuring that only the target particles are tracked (Titelman and Kiørboe 2003). Between 7 and 25 swim tracks, which varied between 1 s to 6 min in duration, were observed for each individual. The time step was always 0.04 s. Swimming speed was measured by counting from position differences between consecutive frames as described in Titelman and Kiørboe (2003) and turning angle as the differences over time steps of three frames.

Percentage of copepods distribution in the food region was determined every 30 min by tracing the movements on the monitor screen. Further details on filming technique and analysis are given in Titelman and Kiørboe (2003).

Statistics

To test for differences between food sources for each copepod species, a one-way analysis of variance (ANOVA) followed by Tukey honestly significant different (HSD) was used. If the assumption for the ANOVA were not met (normality and equality of variances), we used a nonparametric Kruskal–Wallis (KW) test. For *P. elongatus* and *T. longicornis*, where only two food types were tested, we used a simple *t* test. We used the mean values of 2 days (day 3–4 and 7–9) for clearance, ingestion, daily ration and pellet production, and the average over 8 or 10 days for egg production. In the behavioral studies (vertical distribution, swimming speed, and turning angle), we used a 2-way ANOVA to test for differences between fed and starved copepods and diet. Spearman rank correlation analysis was used to evaluate any correlations between copepod responses and food nutritional composition or diatom aldehydes. Only the days, when grazing experiments were conducted, were included in the analysis.

Results

Ingestion and clearance rate

The average clearance rate ranged from about 11 (1G) to 17 (RHO) $\text{ml ind}^{-1} \text{d}^{-1}$ in *Acartia tonsa*, 16 (9B) to 19 (RHO) $\text{ml ind}^{-1} \text{d}^{-1}$ in *Pseudocalanus elongatus*, and 13 (RHO) to 32 (9B) $\text{ml ind}^{-1} \text{d}^{-1}$ in *Temora longicornis* (Fig. 2). *A. tonsa* ingested RHO, 9B, and 1G at a rate ranging from 1.7 (1G) to 3.1 (9B) $\mu\text{g C ind}^{-1} \text{d}^{-1}$ with significantly higher ingestion of 9B than other food items (1-way ANOVA, $F_3 = 9$, $p < 0.001$, Tukey, $p < 0.05$), while neither clearance nor ingestion of 7J were significantly different from zero (*t* test, $p > 0.05$). For *P. elongatus* and *T. longicornis*, average ingestion rate was about 3 $\mu\text{g C ind}^{-1} \text{d}^{-1}$ (for both algae), and 2 (RHO) or 6 (9B) $\mu\text{g C ind}^{-1} \text{d}^{-1}$, respectively. No significant differences were observed in clearance and ingestion rate of *P. elongatus* between diets, but 9B was cleared and ingested more by *T. longicornis* than RHO diet (*t* test, $p < 0.05$).

Ingestion of *A. tonsa* in terms of 20:5(n-3) fatty acid (EPA), PUFA and tFA was also significantly higher for 9B than for other algae (KW, $H = 9.57$, $H_2 = 11.58$, $H_2 = 6.62$, respectively, $p < 0.01$; Fig. 3b, d, e). In contrast, *A. tonsa* feeding on RHO showed a high daily ration of both $\Delta 5$ sterol and 22:6(n-3) fatty acid (DHA) of

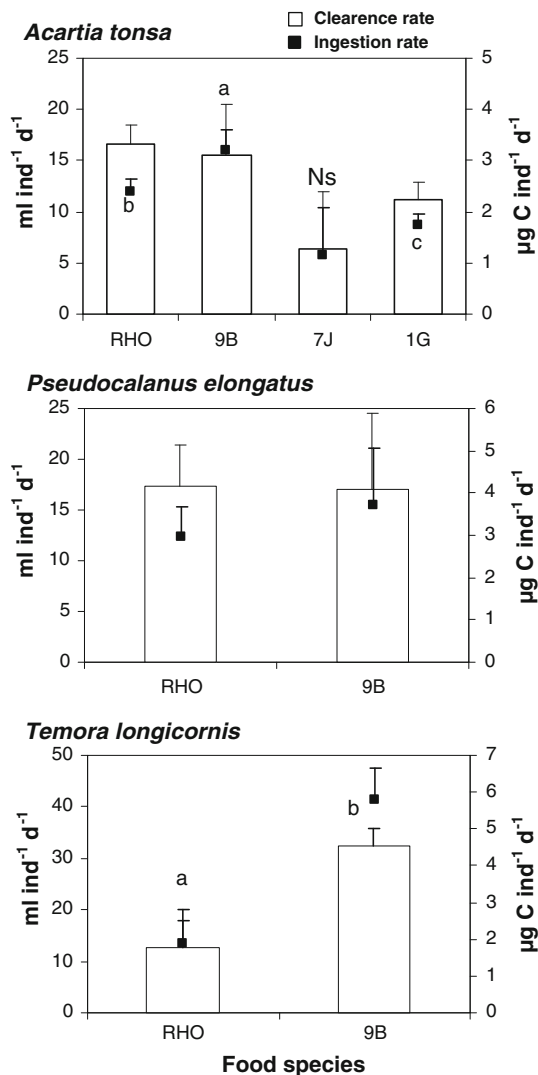

Fig. 2 Copepod clearance (ml ind⁻¹ d⁻¹; columns) and ingestion (µg C ind⁻¹ d⁻¹; symbols) rates on different diets (mean ± SD). (RHO) *Rhodomonas* sp., (9B), *Skeletonema marinoi* GF04-9B (7J), *Skeletonema marinoi* GF04-7J, and (1G) *Skeletonema marinoi* GF04-1G. Different letters denote ingestion rates that are significantly different from each other (Tukey HSD, $p < 0.05$). Ns not significantly different from zero (t test, $p > 0.05$)

>12 ng ind⁻¹ d⁻¹, while significantly lower ingestion of sterols and DHA (<2 and 5 ng ind⁻¹ d⁻¹, respectively) were obtained when feeding on 9B and 1G (1-way ANOVA, $F_2 = 140$, KW, $H = 12.5$, respectively, $p < 0.01$; Fig. 3c, f). For *P. elongatus*, no significant differences were observed in ingestion rates in terms of nitrogen, PUFA, total fatty acids (tFA), and EPA between the diets (t test, $p > 0.05$), but the ingestion of $\Delta 5$ sterol and DHA was significantly higher, >16 ng ind⁻¹ d⁻¹, when feeding on RHO than when feeding on 9B (t test, $p < 0.05$). Similarly, ingestion rates of *T. longicornis* in terms of nitrogen, EPA, PUFA, and tFA on 9B were

significantly higher than RHO, but significantly lower in terms of $\Delta 5$ sterol and DHA.

Pellet production rate

Pellet production reflected ingestion, with copepods on 9B diet generally producing most pellets (Fig. 4). The pellet production ranged from 2.8 (7J) to 18 (9B) pellets ind⁻¹ d⁻¹ in *A. tonsa*, 5 (RHO) to 9 (9B) pellets ind⁻¹ d⁻¹ in *P. elongatus*, and 2 (RHO) to 54 (9B) pellets ind⁻¹ d⁻¹ in *T. longicornis*. Differences in average pellet production by *A. tonsa* between diets were significant (1-way ANOVA, $F_3 = 17$, $p < 0.001$) with the highest rate observed in copepods feeding on 9B (Tukey, $p < 0.001$). Further, pellets produced by *A. tonsa* feeding on 9B had generally larger volume than pellets produced from other food items (Table 2), with the smallest pellets observed from 7J diet. Thus, the total feces volume of *A. tonsa* was significantly higher on 9B than on other diets (1-way ANOVA, $F_3 = 21$, $p < 0.001$, Tukey, $p < 0.001$; Fig. 4). No significant differences were observed in pellet production of *P. elongatus* between different diets, but production in *T. longicornis* was significantly higher feeding on 9B than RHO (t test, $p < 0.05$).

Egg production and hatching success

The daily egg production rate and hatching success of *A. tonsa*, *P. elongatus*, and *T. longicornis* are shown in Fig. 5a. Egg production rates ranged from about 0.8 to 23 eggs female⁻¹ d⁻¹ in *A. tonsa*, 0.5 to 2.4 eggs female⁻¹ d⁻¹ in *P. elongatus*, and 0.6 to 7.9 eggs female⁻¹ d⁻¹ in *T. longicornis*, which corresponded to a weight-specific egg production of 0.01–0.32, 0.01–0.06, and 0.02–0.12 µg C (µg C)⁻¹ d⁻¹, respectively. There were strain-specific differences in the mean *A. tonsa* egg production, with significantly highest production on 1G, second highest on RHO and 9B, and the lowest on 7J (1-way ANOVA, $F_3 = 16$, $p < 0.001$, Tukey, $p < 0.001$). No differences were found for *P. elongatus* between diets (t test, $p > 0.05$). The egg production of *T. longicornis* fed on 9B was initially low, but increased in the course of the experiment, reaching a similar level in days 7–8 as measured previously on RHO (Dutz et al. 2008). The egg production on RHO at the present experiments was unexpectedly low and did not increase similarly to the egg production on 9B. As *T. longicornis* in both treatments (RHO and 9B) originated from the same batch and thus had a similar history, we concluded that the unexplained result on RHO was due to the quality of RHO rather than *T. longicornis* (see “Materials and methods”).

Hatching success at the start of the experiment ranged from 56 to 66% in *A. tonsa*, 64 to 72% in *P. elongatus* and

Fig. 3 **a** Ingestion of nitrogen ($\mu\text{g ind}^{-1} \text{d}^{-1}$), **b** EPA ($\text{ng ind}^{-1} \text{d}^{-1}$), **c** DHA ($\text{ng ind}^{-1} \text{d}^{-1}$), **d** PUFA ($\text{ng ind}^{-1} \text{d}^{-1}$), **e** tFA ($\text{ng ind}^{-1} \text{d}^{-1}$), **f** sterol ($\text{ng ind}^{-1} \text{d}^{-1}$), and **g** PUA ($\text{nmol ind}^{-1} \text{d}^{-1}$), of copepods (Aca: *Acartia tonsa*, Pseu: *Pseudocalanus elongatus*, Tem: *Temora longicornis*) feeding on diatoms and RHO (means \pm SD). *Striped columns: RHO, black columns: 9B, open columns: 1G*. Only species/strains which induced significant ingestion rates were included. *Different letters denote treatments that are significantly different from each other (Tukey HSD, $p < 0.05$)*

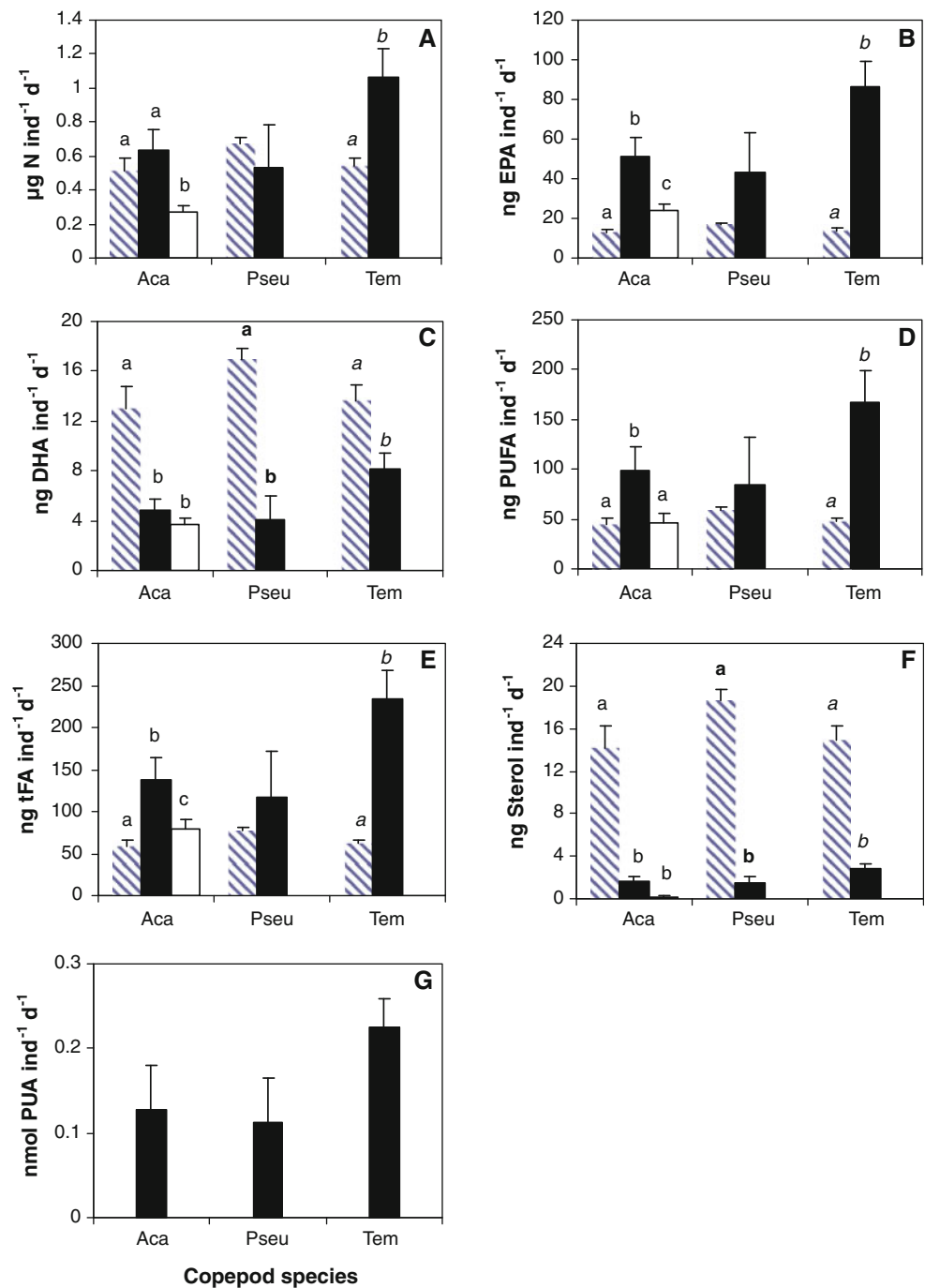

was 33 to 70% in *T. longicornis* (9B) (Fig. 5b). For *T. longicornis* with RHO, hatching success was terminated at day 3 as too few eggs were produced for accurate incubations. Hatching success of *A. tonsa* was similar with all diets until day 6, when the hatching success on 9B decreased to less than 30% in last day of the incubation. The hatching of *P. elongatus* and *T. longicornis* continuously diminished after onset of feeding on 9B diet, although the hatching success with RHO was variable: with *P. elongatus*, the hatching success with 9B corresponded

on average to 63% of the hatching success with RHO. If *T. longicornis* hatching success on RHO was assumed as in Dutz et al. (2008); the hatching success with 9B corresponded to ca. 35% of the hatching with RHO (Fig. 5b). For 7J strain, hatching success could not be measured, since too few eggs were produced.

Egg production of *A. tonsa* was positively correlated with the ingestion of DHA and sterol (Spearman rank correlation: $p < 0.05$; Table 3) and negatively correlated with the C/N and EPA/DHA ratios of the diet. However,

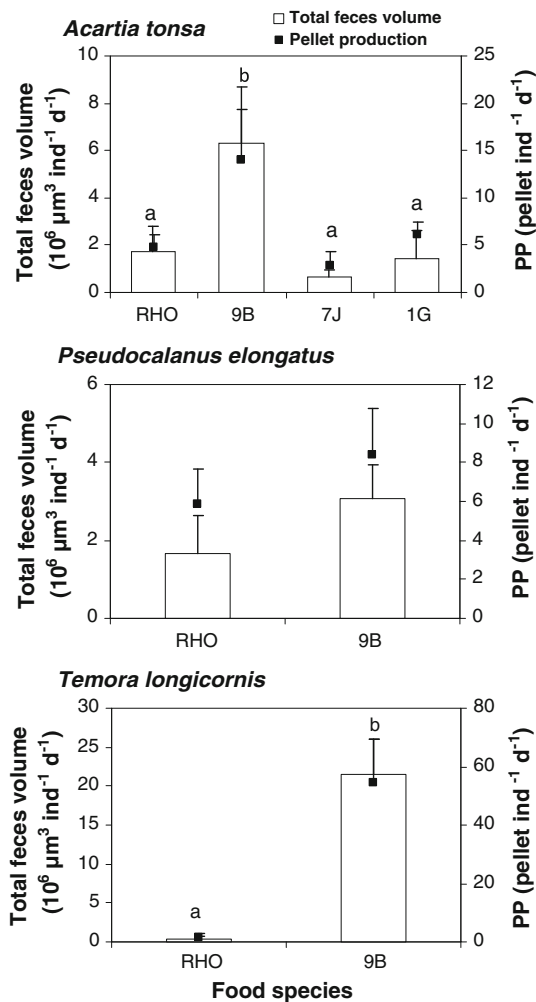

Fig. 4 Total feces volume, ($\times 10^6 \mu\text{m}^3 \text{d}^{-1}$; columns), and pellet production (pellet $\text{ind}^{-1} \text{d}^{-1}$; symbols) of copepods feeding on diatoms and RHO (mean \pm SD). Abbreviations as in Fig. 2; different letters denote treatments that are significantly different from each other (Tukey HSD, $p < 0.05$.)

Table 2 Pellets volume ($\times 10^5 \mu\text{m}^3 \text{d}^{-1}$; average of 30 pellet per treatment) and the efficiency of egg production (E-EP) in terms of carbon (C) feeding on *Rhodomonas* sp. (RHO) and three *Skeletonema marinoi* strains

	Species/strains	<i>Acartia tonsa</i>		<i>Pseudocalanus elongatus</i>		<i>Temora longicornis</i>	
		Mean	SD	Mean	SD	Mean	SD
Feces volume	RHO	3.70	1.50	2.90	1.10	2.40	1.40
	9B	4.50	1.50	3.60	1.70	3.90	1.40
	7J	2.20	1.10				
	1G	2.40	0.80				
E-EP C	RHO	0.21	0.06	0.08	0.02	<i>0.19</i>	<i>0.00</i>
	9B	0.10	0.05	0.09	0.03	0.06	0.01
	7J	–					
	1G	0.20	0.07				

The missing data for 7J are due to the low egg production on this species. For *Temora longicornis*, previous measurement on RHO (E-EP) is given for comparison (Dutz et al. 2008; printed in *italics*)

there was no significant correlation between hatching and ingestion of any of the nutritional components or PUAs. No significant correlation was observed between the egg production of *P. elongatus* and the diverse food components, but hatching was found to significantly correlate with the DHA and sterol content of the diet (Spearman rank correlation: $p < 0.05$). Hatching success of *T. longicornis* with 9B was not correlated with any of the nutritional components or PUAs (Spearman rank correlation: $p > 0.05$), whereas egg production correlated negatively with ingestion in terms of carbon, nitrogen, lipid (EPA, PUFA, and tFA), and PUA (Spearman rank correlation: $p < 0.05$).

Calculation of the efficiency of egg production in *A. tonsa* showed that with RHO and 1G, the ingested carbon was utilized with a higher efficiency (0.21 and 0.20) than with 9B (0.10; Table 2). For *T. longicornis*, the carbon egg efficiency with 9B was ca. 0.06, ca. 3 times lower than observed previously on RHO (Dutz et al. 2008). In *P. elongatus*, the efficiency did not exceed 0.09 with either RHO or 9B.

Behavioral effects

A general assessment of copepod distribution was made, based on the percentage of copepods in the thin layer with food. Both starved and fed *A. tonsa* typically resided in the middle layer, *T. longicornis* in the upper layer, and *P. elongatus* in the bottom layer (Fig. 6). For fed and starved *A. tonsa*, approximately half of the copepods were present in the thin middle layer, with significantly higher abundance in the food layer with *Skeletonema* (strains 9B and 1G) than in FSW control (2-way ANOVA, $F_3 = 7$, $p < 0.001$). For both *T. longicornis* and *P. elongatus*, $< 20\%$ of the copepods remained in the food layer. No significant differences between the experiment (food) and

Fig. 5 a Egg production rate (egg female⁻¹ d⁻¹ ± SD) and **b** egg hatching success (%) of copepods feeding on diatom and RHO during the 8 days incubation (*Acartia tonsa*, *Temora longicornis*) and 10 days incubation (*Pseudocalanus elongatus*). Abbreviations as in Fig. 2. For *Temora longicornis* egg production, previous measurements on RHO (EPR) are given for comparison (Dutz et al. 2008; symbol on dotted line). Open symbols without line show the hatching on diatoms as a percentage of hatching in RHO. Hatching of *T. longicornis* in RHO was estimated based on previous result in Dutz et al. (2008). Note different scales of the x-axis

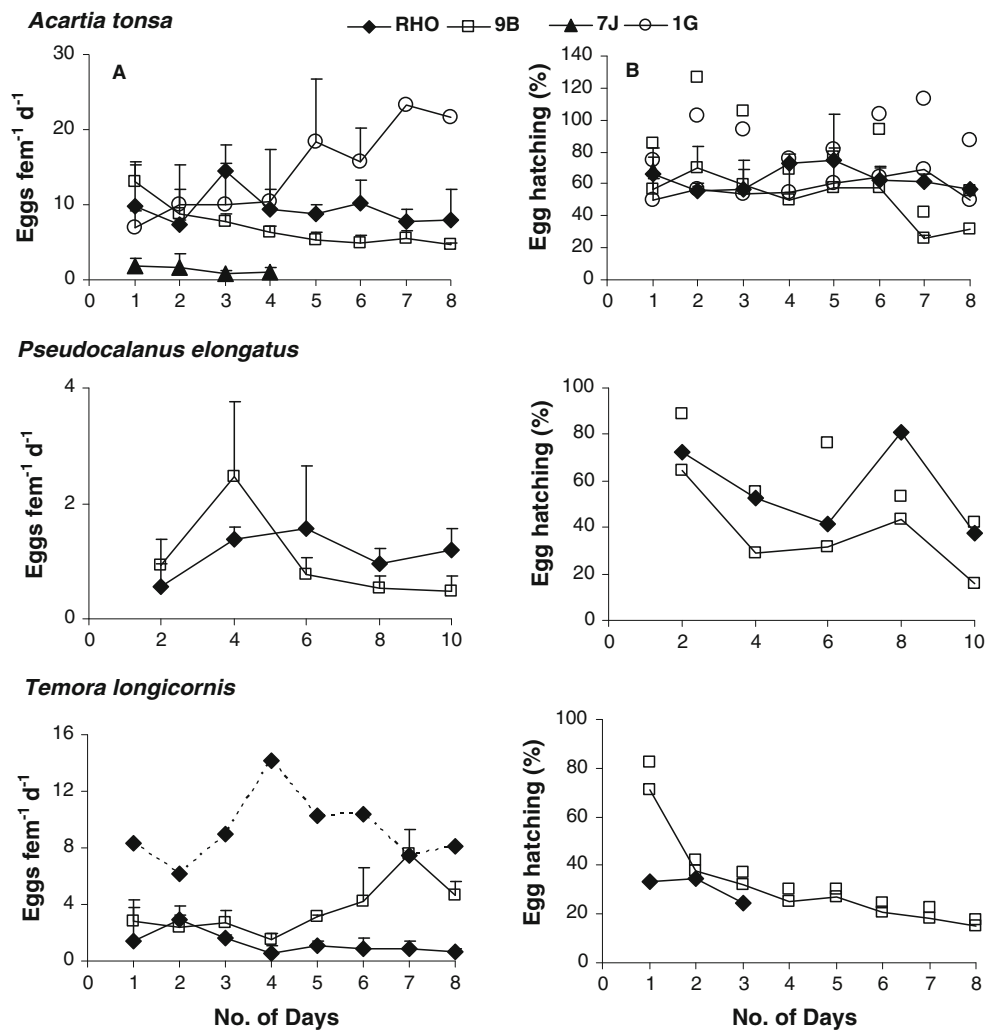

Table 3 Spearman correlation coefficients between reproductive response parameters (EPR; eggs fem⁻¹ d⁻¹ and HS; %) and ingestion of mineral and biochemical components and polyunsaturated

aldehydes (PUAs) in *Acartia tonsa* (n = 25), *Pseudocalanus elongatus* (n = 19), and *Temora longicornis* (n = 11) (using *Rhodomonas* sp. (T-RHO, Dutz et al. 2008) as comparison) females

Copepods	Response	C	N	C/N	EPA	DHA	EPA/DHA	PUFA	tFA	Sterol	Total PUA
<i>Acartia tonsa</i>	EPR	0.15	0.166	-0.507*	-0.499	0.564*	-0.559*	-0.067	-0.243	0.567*	-0.403
	HS	-0.481	0.37	0.013	-0.103	-0.2	0.054	-0.333	-0.309	-0.164	-0.075
<i>Pseudocalanus elongatus</i>	EPR	0.318	0.258	0.248	0.379	-0.121	0.248	0.406	0.418	-0.129	0.401
	HS	0.5	0.563	-0.846	-0.476	0.762*	-0.846	0.149	-0.102	0.615*	-0.564
<i>Temora longicornis</i>	EPR	-0.833**	-0.867*	-0.365	-0.833**	-0.183	-0.548	-0.833**	-0.817*	-0.217	-0.762*
	HS	-0.6	-0.6	-0.707	-0.8	0.4	-0.706	-0.6	-0.632	0.517	-0.8

Only species which induced significant ingestion rates were included. Significance of correlation is given by asterisk: * p < 0.05, ** p < 0.01

FSW control were observed in both fed and starved *P. elongatus* and starved *T. longicornis*. In contrast, copepod concentration in the food layer was elevated in fed *T. longicornis* (2-way ANOVA, F₁ = 8, p < 0.001, Tukey, p < 0.001). We thus did not observe any avoidance of the food patch containing *Skeletonema*, irrespective of the PUA production of the strain.

Comparison of swimming speed showed that copepods moved an average of ~5 mm s⁻¹ in all treatment conditions, with the highest swimming in fed *A. tonsa* with 9B strain (6.2 mm s⁻¹). The turning angle ranged from 0.001 to 0.04 with the largest angle observed in starved *T. longicornis* with 9B strain. Only starved *A. tonsa* (2-way ANOVA, F₃ = 6, p < 0.05; Fig. 7) and fed *P. elongatus*

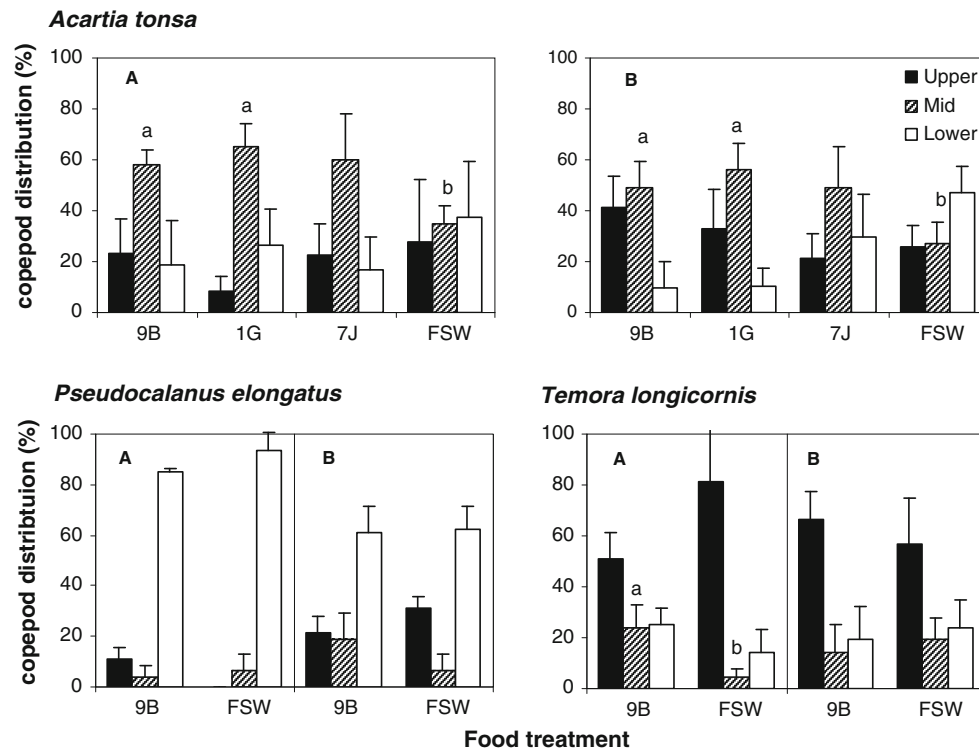

Fig. 6 Distribution (%) of **a** fed and **b** starved copepods in different treatment. *Upper* water column without algae; *Mid* water column with algae; and *Lower* water column without algae. Different letters denote

treatment significantly different from each other (Tukey HSD, $p < 0.05$). Abbreviations as in Fig. 2

(2-way ANOVA, $F_1 = 8$, $p < 0.05$) significantly altered their swimming speed in response to food treatments, while both fed and starved *A. tonsa*, fed *P. elongatus*, and starved *T. longicornis* altered their turning angle (*A. tonsa*, 2-way ANOVA, $F_3 = 23$, for *A. tonsa*, *P. elongatus*, $F_1 = 11$ *T. longicornis*, $F_1 = 5$). Typically, these copepods moved significantly more in food treatment and turned significantly less when placed in FSW but no reduction in swimming activity was observed in the presence of *S. marinoi*.

Discussion

Strain-specific effects of *Skeletonema marinoi*

Our study revealed strong strain-specific effects of *Skeletonema marinoi* on ingestion, egg production, and hatching success of *Acartia tonsa*, summarized in Table 4. All three *Skeletonema* strains differed in size, chain length, and carbon content (Table 1) and induced very different feeding. Typically, 7J was not eaten, while 1G was ingested at a similar rate to the control RHO, and 9B was ingested at even higher quantities. 7J had a low PUA content, suggesting that the low feeding was not influenced by a potential effect of PUA as a feeding deterrent. Instead, low

ingestion could have been due to the small cell size, combined with a relatively long chain length (Table 1), which could have made this chain difficult to ingest. Of the remaining strains, egg production was high on 1G and moderate to low on RHO and 9B, while the hatching success was only reduced on 9B (last day of the incubation). Later, we consider diatom aldehydes, nutritional compounds, and alternative explanations as potential reasons explaining the observed patterns.

Diatom aldehydes

Acartia tonsa has been reported to have a higher reproductive success when feeding on *Skeletonema* than when feeding on *Phaeocystis pouchetii* (Verity and Smayda 1989) and ciliates (Ederington et al. 1995). However, low fecundity and hatching of *Acartia* spp. have also been demonstrated with the same diatom species in several laboratory studies (Ban et al. 1997; Ianora et al. 2003) and in the field, with only 12% of the eggs hatching during a *Skeletonema* bloom (Miralto et al. 1999). These observations of a low reproductive success have been attributed to the production of PUA (Ianora et al. 2009).

In the present study, egg production and hatching of *A. tonsa* had no direct connection to the ingestion of PUA (Table 3). This finding is in agreement with recent

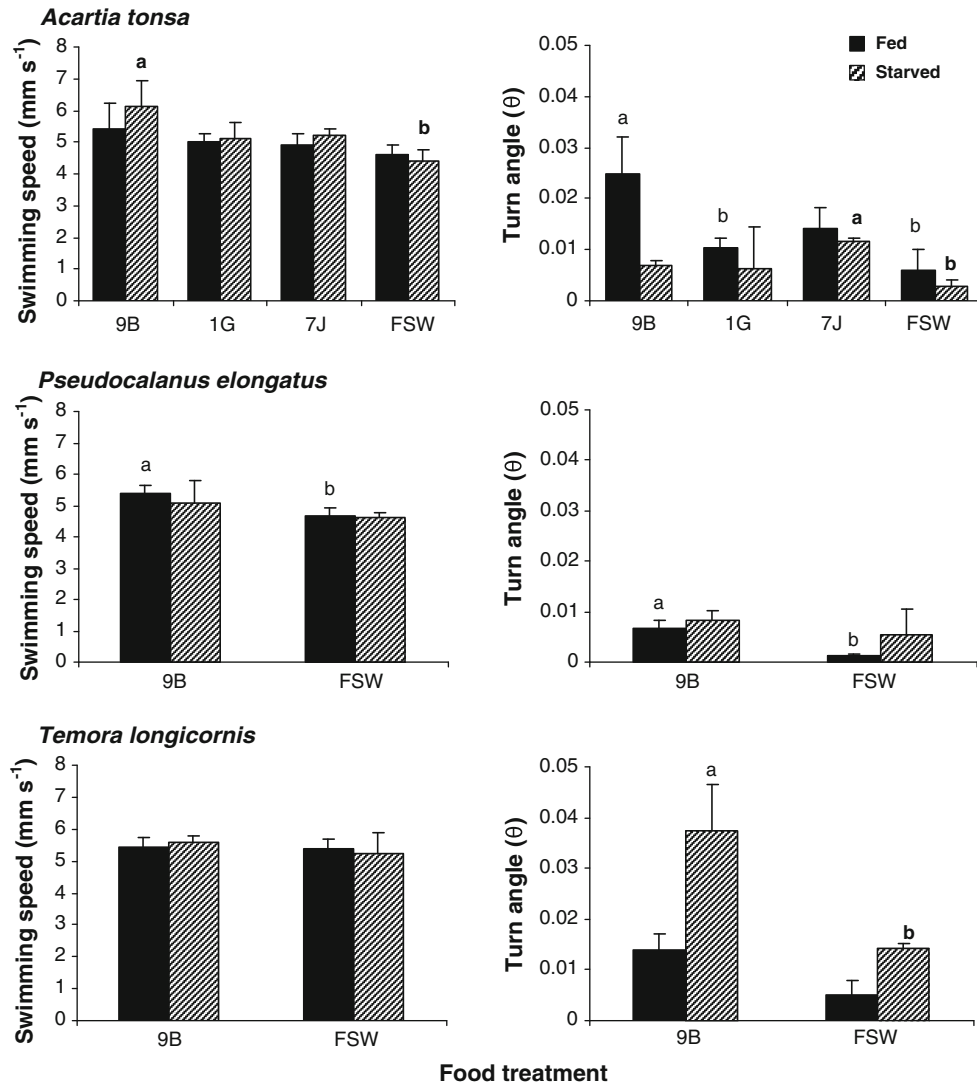

Fig. 7 Swimming speed (mm s⁻¹) and turn angle (θ) of fed and starved *Acartia tonsa*, *Pseudocalanus elongatus*, *Temora longicornis* in different food treatment (mean ± SD) observed in a mid column

with algae. Different letters denote significantly different treatment from each other according to Tukey HSD, *p* < 0.05. Abbreviations as in Fig. 2

Table 4 Overview of effects on the physiology and behavior of three copepod species when fed three different strains of *Skeletonema marinoi*

Variable	<i>S. marinoi</i> strain/copepod species				
	9B			7J	1G
	<i>Acartia tonsa</i>	<i>Pseudocalanus elongatus</i>	<i>Temora longicornis</i>	<i>Acartia tonsa</i>	
Egg production	–	–	+	*	+
Hatching success	=/–	–	–	*	=
Clearance rate	=	=	+	ns	=
Ingestion rate	+	=	+	ns	–
Pellets production	+	=	+	–	=
Swimming speed (fed copepods)	=	+	=	=	=
Turning angle (fed copepods)	+	+	=	=	=

Effects are based on the differences with *Rhodomonas* sp. (RHO) (physiology) and filtered seawater (behavior) as control. + high production/ingestion/behavior, – low production/ingestion/behavior, * too low eggs/no hatching (7J), = similar/unaffected, ns not significant from zero

laboratory (*Temora longicornis*, Dutz et al. 2008) and field (from the English Channel off Roscoff, *Calanus helgolandicus*, Poulet et al. 2006; Wichard et al. 2008) studies showing no evidence that PUAs were involved in the overall observed reproduction failure. Further, the daily ingested amount of PUA by *A. tonsa* in this study was estimated to be 0.004–0.02 $\mu\text{g ind}^{-1} \text{d}^{-1}$ (29–86 pmol $\text{ind}^{-1} \text{d}^{-1}$), which is higher than the 100 pg (=0.0001 μg) daily ingestion of decadienal, which was reported by Ianora et al. (2004) to have strong adverse effects on copepod reproduction. Our estimated ingestion rate was also close to the highest ingestion reported by Dutz et al. (2008) of 100 pmol $\text{ind}^{-1} \text{d}^{-1}$ (0.1 $\mu\text{g ind}^{-1} \text{d}^{-1}$), (note that there is a calculation error in Fig. 2f of Dutz et al. 2008; with a one magnitude difference), which did not generate apparent effects on reproduction. The results indicate that either there is no constant critical level of PUA ingestion for harmful effects to occur or other factors than PUAs explain the observed strain-specific effects for reproduction.

Nutritional deficiency

The diatom strains also differed in their composition of lipids, especially with respect to the contents of specific PUFAs and sterols, as well as in their C/N ratio. Of the two ingested strains, 9B and 1G had a relatively similar fatty acid contents (per volume unit, Table 1). However, there was a fourfold difference in the volume-specific sterol content of these strains, with 9B containing ca. 3 times as much sterols as 1G. In addition, the C/N ratio was lower in 9B and this strain thus appeared more beneficial than 1G (for sterol and nitrogen content). Nevertheless, 1G induced higher egg production, hatching success and gave higher egg production efficiency.

If the egg production of *A. tonsa* was plotted against ingestion of different compounds, the egg production appeared positively correlated with the ingestion of DHA and sterols and negatively correlated with the EPA/DHA and C/N ratios. Various studies have reported the effect of these compounds on copepods growth and recruitment. For instance, a low C/N ratio (Jones and Flynn 2005) or a high concentration of unsaturated fatty acid (Kleppel et al. 1998; Broglio et al. 2003), especially EPA and DHA (Jónasdóttir 1994; Jónasdóttir and Kiørboe 1996; Shin et al. 2003) and sterols (Klein Breteler et al. 1999; Hassett 2004) in the diets have been shown to have beneficial effects. The C/N ratio of the algae varied from 4.8 to 6.3, indicating that the differences in C/N ratios were small (Table 1). Although the ratios in our study were lower than the C/N previously reported to have significant effect on fecundity (Kiørboe 1989), it appears that particulate nitrogen content of food did have an effect on *A. tonsa*

egg production, as also shown in previous studies (Koski et al. 2006; Peters et al. 2007). However, even though stoichiometric analysis can be indicative for food quality limitation, there is evidence that C/N ratios are not adequate predictors to assure reproductive success in crustaceans (reviewed by Broglio et al. 2003) and the effect of mineral nutrients can be connected to changes in biochemical compounds of the algae (Klein Breteler et al. 2005).

The importance of the balance in EPA/DHA ratios has been observed in several previous studies (Støttrup and Jensen 1990; Jónasdóttir 1994; Jónasdóttir and Kiørboe 1996), with a smaller ratio tending to promote a high reproductive success in copepods. Although it is not really clear why low EPA/DHA ratio profits copepod reproduction, it has been demonstrated regularly that inappropriate composition of essential fatty acids lead to a lower reproductive success (e.g., Evjemo et al. 2008).

The significant relationship of egg production with sterol supports other studies indicating that the sterol composition obtained by females is of some importance in controlling reproduction rates (Klein Breteler et al. 1999; Hassett 2004). Recent studies reported that cholesterol is the dominant sterol in crustaceans and is required for growth, egg production, and hatching (Hassett 2004; Crockett and Hassett 2005). However, in our study, no cholesterol was detected in the 1G diet (Table 1), suggesting that high egg production rate could be maintained without significant cholesterol content in the diet.

Alternative explanations

Hatching success of *A. tonsa* was not correlated with the ingestion of carbon, nitrogen, PUFAs, sterols, or PUAs. It is possible that *A. tonsa* hatching success suffered from a deficiency of other biochemical compounds, not included in our measurements, or was influenced by specific metabolites. These could include, e.g., amino acids, proteins, various vitamins (e.g., Kleppel and Burkart 1995), dimethyl sulfide, and other unidentified metabolites (see Barofsky et al. 2009). Besides that, the production of fatty acid hydroperoxides (FAHs) and oxylipin such as hydroxyacids and epoxyalcohols have been observed to depress the viability of copepods (Fontana et al. 2007b). Recently, Ianora et al. (2010) observed negative effect on *Temora stylifera* feeding on *Pseudo-nitzschia delicatissima*, which does not produce PUA but oxylipins, suggesting that these metabolites may be another important factor behind the negative effects of some diatoms diet in copepods. However, it is uncertain at present how widespread this oxylipin production is compared to PUAs.

Behavioral effects

In the present study, higher aggregation of *A. tonsa* in diatom food patch clearly showed that this copepod is able to locate high food concentration. This result is consistent with previous study using a similar setup (Tiselius 1992) where a high aggregation of *A. tonsa* remained in the thin layer of the diatom *Thalassiosira weissflogii*. As *A. tonsa* does not store energy reserves, it should have developed strong behavior to remain in the food patches. Distinct effects on *A. tonsa* behavior were also observed between FSW control and food treatment in our study. The pattern of increased retention in a food layer can result from area-restricted search strategy in which swimming and turning angles increase when entering a food patch (Tiselius 1992).

In contrast, Bochdasky and Bollen (2004) reported no aggregation of *Acartia hudsonica* in the food layer of *Skeletonema costatum* suggesting that this diatom is not a preferred food source. However, although no aggregation was evident in their 12-h observation, copepods were found crowding in the food patch in the first 2 to 4 h of the experiment. We assumed that the behavioral changes in relation to different food properties and PUA production would be fast, and 2-h observations would thus be adequate to assess the potential changes in copepods swimming activity. Because the average time that it takes for the copepods to fill their guts in high food concentrations is relatively short (e.g., 2-h; Leising and Franks 2000), we argue that the behavioral changes during the first hours following changed food conditions would be the most relevant. Although we did not observe any differences in copepod behavior related to the different strains, we cannot, however, exclude that copepod swimming and aggregation behavior could have changed during a longer experimental duration.

Thus, our result indicates that PUA-producing algae do not exert any deterrent response on copepods. This result supports previous study showing that *A. tonsa* exhibit minimal behavioral effects when exposed to *Karenia brevis* or brevetoxins with higher toxic accumulation in their body (Cohen et al. 2007). In contrast, *Temora turbinata* in the Gulf of Mexico actively avoided dense concentration of *Karenia brevis*, suggesting that the behavior of this species provide some refuge from *Karenia brevis* toxicity (Lester et al. 2008). There might thus be species-specific differences in copepod behavior as a response to toxic algae, although this was not visible with *S. marinoi*.

Copepod-specific effects of the 9B strain

The 9B strain of *Skeletonema* induced a reduction in egg production in *A. tonsa* and *P. elongatus* and a reduction in hatching success in *A. tonsa* and *T. longicornis*, while

maximum egg production of *T. longicornis* (day 7–8) and *P. elongatus* hatching success remained relatively high. It has been long known that similar diatom species produce inconsistent effects for different copepod species (Ianora et al. 2009). For instance, Ban et al. (1997) showed a strong reduction in fecundity and egg viability in *Acartia clausi* but not in hatching of *Calanus helgolandicus* and neither of the two in *Calanus finmarchicus*, when feeding on *S. costatum*. We can exclude the effects of growth-stage specific PUA production in the food algae, since the 9B strain was used at the same time and with the same concentration for all three copepod species. However, Ianora et al. (2009) also suggest that diatom effects on copepod recruitment can vary greatly between copepod species, probably due to differing copepod sensitivity or detoxification capacity. Although *A. tonsa* did not show any significant correlation between egg production/egg hatching and PUA ingestion with the three *S. marinoi* strains (see earlier), the other two copepods species were only tested with 9B strain. Thus, our results cannot exclude differences between the copepod species in sensitivity or detoxification capacity.

It also appears that copepods have species-specific differences in fatty acid requirements (Jónasdóttir et al. 2009 and references therein). In the present study, we only observed a positive correlation between egg production of *A. tonsa* and hatching of *P. elongatus* and DHA, and sterol ingestion. The reason behind these species-specific responses remains unclear, but could, for instance, originate from different internal sources of lipid in females (Lee et al. 2006), which may result in different dependency on fatty acid ingestion in our study.

It appeared that only *A. tonsa* was remaining in the food patch, while *T. longicornis* and *P. elongatus* were mostly located either above or below it. Similar to *A. tonsa*, *T. longicornis* has also been observed to increase their time spent in a region of high food concentration (Woodson et al. 2005). As *T. longicornis* is a species with high metabolic requirements and low energy reserves, it can also be expected to respond quickly to changes in food quantity and quality (Mayzaud et al. 1992). However, although 9B was ingested at higher rate than the other food items in the grazing experiments, *T. longicornis* aggregated mostly in the upper part of the aquarium with FSW. The cause of this response is not clear, but one possible explanation is that density gradients may act as barriers to vertical migration for this copepod, thus resulting in aggregations at these boundaries due to a physical or a behavioral barrier (Woodson et al. 2005).

Pseudocalanus elongatus was observed to be distributed mostly in the bottom of the aquarium. *P. elongatus* has been found to store energy in the form of lipid droplets, available as long-term energy reserve and can thus survive

starvation longer than *T. longicornis* (Koski and Breteler 2003). It has also been observed that *Pseudocalanus minutus* and *Calanus finmarchicus* are capable of withstanding long period of starvation, suggesting that they can metabolically remove themselves from changes in food environment (Dagg 1977). Fast behavioral response to food patches may, therefore, not be that essential for *P. elongatus* survival. A starving response by *T. longicornis* was demonstrated by a higher turning frequency in 9B than in the FSW control. In contrast, starved *P. elongatus* showed no significant response in their behavior, suggesting that species-specific life strategies give species-specific behavioral characteristic in feeding and swimming.

In conclusion, the observed negative effects of *S. marinoi* on feeding, egg production, and hatching success indicate that one diatom species can range from being a high quality food to directly inducing inhibitory effects. Different strains of *S. marinoi* thus induce widely different responses on copepod physiology, ranging from strongly reduced feeding (7J) and moderately reduced egg production (9B) to high ingestion, egg production and hatching (1G). Although inconclusive, our results show clearly that (1) PUA production of diatoms cannot explain the reduction in copepod reproduction, (2) all *S. marinoi* strains are not harmful, and (3) specific lipids typically appear profitable for reproduction, although the different nutritional demands of different species and life stages, as well as the potential co-limitation of different compounds, make it unlikely that one element could explain the reproduction.

Although the species diversity in phytoplankton blooms is typically lower than at the times of intermediate phytoplankton biomass (Irigoien et al. 2004), diatoms, and especially *S. marinoi*, have a high strain-specific genetic variability (Saravanan and Godhe 2010). Our results show that this strain-specific variability is an important factor controlling the interactions between diatoms and their copepod grazers. It is therefore important to identify the specific characteristics of local diatoms in order to evaluate their potential impact on copepods (Pohnert et al. 2002). Future studies should consider these strain-specific interactions, together with the interacting effects of different mineral, biochemical, and toxic compounds, and their relevance for copepod secondary production. In our opinion, looking into details of copepod-diatom interactions might prove useful when predicting the copepod population dynamics during diatom blooms.

Acknowledgments The authors wish to thank the Nordic Marine Academy, the Ministry of Higher Education, Malaysia and University Malaysia Terengganu for funding. We also thank Johanna Bergkvist for providing the *Skeletonema marinoi* strains; Thomas Kiørboe and Hans Henrik Jacobsen for methodological guidance; Erik Lundberg and Tommy Olofsson for chemical analysis. The use of laboratory facilities at Denmark Technical University is gratefully acknowledged.

Open Access This article is distributed under the terms of the Creative Commons Attribution Noncommercial License which permits any noncommercial use, distribution, and reproduction in any medium, provided the original author(s) and source are credited.

References

- Ask J, Reinkainen M, Båmstedt U (2006) Variation in hatching success and egg production of *Eurytemora affinis* (Calanoida, Copepoda) from the Gulf of Bothnia, Baltic Sea, in relation to abundance and clonal differences of diatoms. *J Plankton Res* 28:683–694
- Ban S, Burns C, Castel J, Chaudron Y, Christou E, Escribano R, Umani S, Gasparini S, Guerro-Ruiz F, Hoffmeyer M, Ianora A, Kang H-K, Laabir M, Lacoste A, Miralto A, Ning X, Poulet S, Rodriguez V, Runge J, Shi J, Starr M, Uye S, Wang Y (1997) The paradox of diatom-copepod interactions. *Mar Ecol Prog Ser* 157:287–293
- Barofsky A, Vidoudez C, Pohnert G (2009) Metabolic profiling reveals growth stage variability in diatom exudates. *Limnol Oceanogr Methods* 7:382–390
- Bochdasky AB, Bollen SM (2004) Relevant scales in zooplankton ecology: distribution, feeding, and reproduction of the copepod *Acartia hudsonica* in response to thin layers of the diatom *Skeletonema costatum*. *Limnol Oceanogr* 49:625–635
- Broglio E, Jónasdóttir SH, Calbet A, Jakobsen HH, Saiz E (2003) Effect of heterotrophic versus autotrophic food on feeding and reproduction of the calanoid copepod *Acartia tonsa*: relationship with prey fatty acid composition. *Mar Ecol Prog Ser* 31:267–278
- Buskey EJ (1984) Swimming pattern as an indicator of the roles of copepod sensory systems in the recognition of food. *Mar Biol* 79:165–175
- Cohen JH, Tester PA, Richard B, Forward RB Jr (2007) Sublethal effects of the toxic dinoflagellate *Karenia brevis* on marine copepod behavior. *J Plankton Res* 29:301–315
- Crockett EL, Hassett RP (2005) A cholesterol-enriched diet enhances egg production and egg viability without altering cholesterol content of biological membranes in the copepod *Acartia hudsonica*. *Physiol Biochem Zool* 78:424–433
- Dagg M (1977) Some effects of patchy food environments on copepods. *Limnol Oceanogr* 22:99–107
- Daro MH (1988) Migratory and grazing behavior of copepods and vertical distribution of phytoplankton. *Bull Mar Sci* 43:710–729
- Dutz J, Koski M, Jónasdóttir SH (2008) Copepod reproduction is unaffected by diatom aldehydes or lipid composition. *Limnol Oceanogr* 53:225–235
- Ederington MC, Mcmanus GB, Harvey HR (1995) Trophic transfer of fatty acids, sterols, and a triterpenoid alcohol between bacteria, a ciliate, and the copepod *Acartia tonsa*. *Limnol Oceanogr* 40:860–867
- Evjemo JO, Tokle N, Vadstein O, Olsen Y (2008) Effect of essential dietary fatty acids on egg production and hatching success of the marine copepod *Temora longicornis*. *J Exp Mar Biol Ecol* 365:31–37
- Fontana A, d'Ippolito G, Cutignano A, Romano G, Ianora A, Miralto A, Cimino G (2007a) Oxylipin pathways in marine diatoms: a look at the chemical aspects. *Pure Appl Chem* 79:481–490
- Fontana A, d'Ippolito G, Cutignano A, Romano G, Lamari N, Massa Gallucci A, Cimino G, Miralto A, Ianora A (2007b) LOX-induced lipid peroxidation as mechanism responsible for the detrimental effect of marine diatoms on zooplankton grazers. *Chem BioChem* 8:1810–1818

- Frost BW (1972) Effects of size and concentration of food particles on the feeding behavior of the marine planktonic copepod *Calanus pacificus*. *Limnol Oceanogr* 17:805–815
- Hasset RP (2004) Supplementation of a diatom diet with cholesterol can enhance copepod egg production rates. *Limnol Oceanogr* 49:488–494
- Holste L, St. John MA, Peck MA (2009) The effects of temperature and salinity on reproductive success of *Temora longicornis* in the Baltic Sea: a copepod coping with a tough situation. *Mar Biol* 156:527–540
- Ianora A, Poulet SA, Miralto A (2003) The effects of diatoms on copepod reproduction: a review. *Phycologia* 42:351–363
- Ianora A, Miralto A, Poulet SA, Carotenuto Y, Buttino I, Romano G, Casotti R, Pohnert G, Wichard T, Colucci-D'Amato L, Terrazzano G, Smetacek V (2004) Aldehyde suppression of copepod recruitment in blooms of a ubiquitous planktonic diatom. *Nature* 429:403–407
- Ianora A, Caotti R, Bastianini M, Brunet C, d'Ippolito G, Aciri F, Fontana A, Cutignano A, Turner J, Miralto A (2009) Low reproductive success for copepods during a bloom of the non-aldehyde-producing diatom *Cerataulina pelagica* in the North Adriatic Sea. *Mar Ecol* 29:399–411
- Ianora A, Romano G, Carotenuto Y, Esposito F, Roncalli V, Buttino I, Miralto A (2010) Impact of the diatom oxylipin 15S-HEPE on the reproductive success of the copepod *Temora stylifera*. *Hydrobiologia*. doi: 10.1007/s10750-010-0420-7
- Irigoien X, Harris RP, Verheye HM, Joly P, Runge J, Starr M, Pond D, Campbell R, Shreeve R, Ward P, Smith AN, Dam HG, Peterson W, Tirelli V, Koski M, Smith T, Harbour D, Davidson R (2002) Copepod hatching success in marine ecosystems with high diatom concentrations. *Nature* 419:387–389
- Irigoien X, Huisman J, Harris RP (2004) Global biodiversity patterns of marine phytoplankton and zooplankton. *Nature* 429:864–867
- Jónasdóttir SH (1994) Effects of food quality on the reproductive success of *Acartia tonsa* and *Acartia hudsonica*: laboratory observations. *Mar Biol* 121:67–81
- Jónasdóttir SH, Kiørboe T (1996) Copepod recruitment and food composition: do diatoms affect hatching success? *Mar Biol* 125:743–750
- Jónasdóttir S, Visser AW, Jespersen C (2009) Assessing the role of food quality in the production and hatching of *Temora longicornis* eggs. *Mar Ecol Prog Ser* 382:139–150
- Jónasdóttir S, Dutz J, Koski M, Yebra L, Jakobsen HH, Vidoudez C, Pohnert G, Nejstgaard JC (2011) Extensive cross disciplinary analysis of biological and chemical control of *Calanus finmarchicus* reproduction during an aldehyde forming diatom bloom in mesocosms. *Mar Biol*. doi:10.1007/s00227-011-1705-8
- Jones RH, Flynn KJ (2005) Nutritional status and diet composition affects the nutritional value of diatoms as copepod prey. *Science* 307:1457–1458
- Kiørboe T (1989) Phytoplankton growth rate and nitrogen content: implications for feeding and fecundity in a herbivorous copepod. *Mar Ecol Prog Ser* 55:229–234
- Kiørboe T (2007) Mate finding, mating, and population dynamics in a planktonic copepod *Oithona davisae*: there are too few males. *Limnol Oceanogr* 52:1511–1522
- Kiørboe T, Møhlenberg F, Riisgård HU (1985) In situ feeding rates of planktonic copepods: a comparison of four methods. *J Exp Mar Biol Ecol* 88:67–81
- Klein Breteler WCM, Fransz HG, Gonzalez SR (1982) Growth and development of four calanoid copepod species under experimental and natural conditions. *Neth J Sea Res* 16:195–207
- Klein Breteler WCM, Schogt N, Baas M, Schouten S, Kraay GW (1999) Trophic upgrading of food quality by protozoans enhancing copepod growth: role of essential lipids. *Mar Biol* 135:191–198
- Klein Breteler WCM, Schogt N, Rampen S (2005) Effect of diatom nutrient limitation on copepod development: role of essential lipids. *Mar Ecol Prog Ser* 291:25–133
- Kleppel GS, Burkart CA (1995) Egg production and nutritional environment of *Acartia tonsa*: the role of food quality in copepod nutrition. *ICES J Mar Sci* 52:297–304
- Kleppel GS, Burkart CA, Houchin L (1998) Nutrition and the regulation of egg production in the calanoid copepod *Acartia tonsa*. *Limnol Oceanogr* 43:1000–1007
- Koski M, Breteler WK (2003) Influence of diet on copepod survival in the laboratory. *Mar Ecol Prog Ser* 264:73–82
- Koski M, Breteler WK, Schogt N, Gonzalez S, Jakobsen HH (2006) Life-stage-specific differences in exploitation of food mixtures: diet mixing enhances copepod egg production but not juvenile development. *J Plankton Res* 28:919–936
- Koski M, Richard T, Jónasdóttir S (2008) “Good” and “bad” diatoms: development, growth and juvenile mortality of the copepod *Temora longicornis* on diatom diets. *Mar Biol* 154:719–734
- Lee RF, Hagen W, Kattner G (2006) Lipid storage in marine zooplankton. *Mar Ecol Prog Ser* 307:273–306
- Leising AW (2002) Copepod foraging in thin layers using SEARCH (Simulator for Exploring Area-Restricted search in Complex Habitats). *Mar Model* 2:1–18
- Leising AW, Franks PJS (2000) Copepod vertical distribution within a spatially variable food source: a simple foraging strategy model. *J Plankton Res* 22:999–1024
- Lester K, Heil C, Neely M, Spence D, Murasko S, Hopkins T, Sutton T, Burghart S, Bohrer R, Remsen A (2008) Zooplankton and *Karenia brevis* in the Gulf of Mexico. *Cont Shelf Res* 28:99–111
- Mayzaud P, Roche-Mayzaud O, Razouls S (1992) Medium term time acclimation of feeding and digestive enzyme activity in marine copepods: influence of food concentration and copepod species. *Mar Ecol Prog Ser* 89:197–212
- Miralto A, Barone G, Romano G, Poulet SA, Ianora A, Russo L, Buttino I, Mazzarella G, Laabir M, Cabrini M, Giacobbe MG (1999) The insidious effect of diatoms on copepod reproduction. *Nature* 402:173–176
- Peters J, Dutz J, Hagen W (2007) Role of essential fatty acids on the reproductive success of the copepod *Temora longicornis* in the North Sea. *Mar Ecol Prog Ser* 341:153–163
- Pierson JJ, Halsband-Lenk C, Leising AW (2005) Reproductive success of *Calanus pacificus* during diatom blooms in Dabob Bay, Washington. *Prog Oceanogr* 67:314–331
- Pohnert G, Lumineau O, Cueff A, Adolph S, Cordevant C, Lange M (2002) Are volatile unsaturated aldehydes from diatoms the main line of chemical defence against copepods. *Mar Ecol Prog Ser* 245:33–45
- Poulet SA, Wichard T, Ledoux JB, Lebreton B, Marchetti J, Dancie C, Bonnet D, Cueff A, Morin P, Pohnert G (2006) Influence of diatoms on copepod reproduction. I. Field and laboratory observations related to *Calanus helgolandicus* egg production. *Mar Ecol Prog Ser* 308:129–142
- Renz J, Hirche HJ (2006) Life cycle of *Pseudocalanus acuspes* Giesbrecht (Copepoda, Calanoida) in the Central Baltic Sea: I. seasonal and spatial distribution. *Mar Bio* 148:567–580
- Runge JA, Roff JC (2000) The measurement of growth and reproductive rates. In: Harris R (ed) ICES zooplankton methodology manual. Academic, New York, pp 401–454
- Rynearson TA, Newton JA, Armbrust EV (2006) Spring bloom development, genetic variation, and population succession in the planktonic diatom *Ditylum brightwellii*. *Limnol Oceanogr* 51:1249–1261
- Saravanan V, Godhe A (2010) Genetic heterogeneity and physiological variation among seasonally separated clones of *Skeletonema*

- marinoi* (Bacillariophyceae) in the Gullmar Fjord, Sweden. Eur J Phycol 45:177–190
- Sarno D, Kooistra HCF, Medlin LK, Percopo I, Zingone A (2005) Diversity of the genus *Skeletonema* (Bacillariophyceae). II. An assessment of the taxonomy of *S. costatum*-like species with the description of four new species. J Phycol 41:151–176
- Shin K, Jang MC, Jang PK, Ju SJ, Lee TK, Chang M (2003) Influence of food quality on egg production and viability of the marine planktonic copepod *Acartia omorii*. Prog Oceanogr 57:265–277
- Steele JH (1974) The structure of marine ecosystems. Harvard University Press, Cambridge
- Støttrup JG, Jensen J (1990) Influence of algal diet on feeding and egg-production of the calanoid copepod *Acartia tonsa* Dana. J Exp Mar Biol Ecol 141:87–105
- Taylor RL, Abrahamsson K, Godhe A, Wängberg S-Å (2009) Seasonal variability in polyunsaturated aldehyde production potential between strains of *Skeletonema marinoi* (Bacillariophyceae). J Phycol 45:46–53
- Tiselius P (1992) Behavior of *Acartia tonsa* in patchy food environments. Limnol Oceanogr 37:1640–1651
- Tiselius P, Jonsson PR (1990) Foraging behavior of six calanoid copepods: observations and hydrodynamic analysis. Mar Ecol Prog Ser 66:23–33
- Titelman J, Kiørboe T (2003) Motility of copepod nauplii and implications for food encounter. Mar Ecol Prog Ser 247:123–135
- Turner JT, Tester PA (1989) Zooplankton feeding ecology: nonselective grazing by the copepods *Acartia tonsa* Dana, *Centropages velificatus* de Oliveira, and *Eucalanus pileatus* Giesbrecht in the plume of the Mississippi River. J Exp Mar Bio Ecol 126:21–43
- Turner JT, Ianora A, Miralto A, Laabir M, Esposito F (2001) Decoupling of copepod grazing rates, fecundity and egg hatching success on mixed and alternating diatom and dinoflagellate diets. Mar Ecol Prog Ser 220:187–199
- Verity P, Smayda TJ (1989) Nutritional value of *Phaeocystis pouchetii* (Prymnesiophyceae) and other phytoplankton for *Acartia* spp. (Copepoda): ingestion, egg production, and growth of nauplii. Mar Biol 100:161–171
- Vidoudez C, Pohnert G (2008) Growth phase-specific release of polyunsaturated aldehydes by the diatom *Skeletonema marinoi*. J Plankton Res 30:1305–1313
- Vidoudez C, Nejstgaard JC, Jakobsen HH, Pohnert G (2011) Dynamics of dissolved and particulate polyunsaturated aldehydes in mesocosms inoculated with different densities of the diatom *Skeletonema marinoi*. Mar Drugs 9:500–513
- Wichard T, Gerecht A, Boersma M, Poulet SA, Wiltshire K, Pohnert G (2007) Lipid and fatty acid composition of diatoms revisited: rapid wound-activated change of food quality parameters influences herbivorous copepod reproductive success. Chem BioChem 8:1146–1153
- Wichard T, Poulet SA, Boulezeix A-L, Ledoux JB, Lebreton B, Marchetti J, Pohnert G (2008) Influence of diatoms on copepod reproduction. II. Uncorrelated effects of diatom-derived α , β , γ , δ -unsaturated aldehydes and polyunsaturated fatty acids on *Calanus helgolandicus* in the field. Prog Oceanogr 77:30–44
- Woodson CB, Webster DR, Weissburg MJ, Yen J (2005) Response of copepods to physical gradients associated with structure in the ocean. Limnol Oceanogr 50:1552–1564