

# On the Recursive Fractional Variable-Order Derivative: Equivalent Switching Strategy, Duality, and Analog Modeling

Dominik Sierociuk · Wiktor Malesza ·  
Michał Macias

Received: 13 November 2013 / Revised: 10 September 2014 / Accepted: 11 September 2014 /  
Published online: 5 October 2014  
© The Author(s) 2014. This article is published with open access at Springerlink.com

**Abstract** In this paper, a switching strategy for recursive fractional variable-order derivative is proposed. This strategy can be interpreted as an explanation of order switching mechanism for this particular type of derivative. Additionally, important properties of variable fractional order derivatives, required for prove the main result, are introduced both in a difference equation and a matrix form. Duality between the recursive and standard variable-order derivative is detailed derived. Based on the switching scheme, an analog realization of the recursive variable-order derivative definition is presented. Experimental results obtained for the analog realization are compared to the numerical results.

**Keywords** Fractional calculus · Variable-order differentiation · Analog modeling

## 1 Introduction to Fractional Calculus

Fractional calculus is a generalization of traditional integer order integration and differentiation actions onto non-integer order. The idea of such a generalization has been mentioned in 1695 by Leibniz and L'Hospital. In the end of 19th century, Liouville and Riemann introduced first definition of fractional derivative. However, only just in late 60' of the 20th century, this idea drew attention of engineers. Fractional cal-

---

D. Sierociuk (✉) · W. Malesza · M. Macias  
Institute of Control and Industrial Electronics, Warsaw University of Technology,  
Koszykowa 75, 00-662 Warsaw, Poland  
e-mail: dsieroci@ee.pw.edu.pl

W. Malesza  
e-mail: wmalesza@ee.pw.edu.pl

M. Macias  
e-mail: michal.macias@ee.pw.edu.pl

culus was found a very useful tool for modeling the behavior of many materials and systems, especially those based on the diffusion processes. Ones of such devices that can be modeled more efficiently by fractional calculus are ultracapacitors. Models of these electronic storage devices, which capacity can reach even thousands of Farads, based on fractional order models, were presented in [4,5]. Another system that can be successfully modelled using fractional calculus methods is the heat transfer process in both homogeneous and non-homogeneous media [6,25]. Numerical realization of fractional dynamic systems is more complicated than for integer order case, that is why analog modeling methods for fractional order systems are widely used, e.g., in fractional order chaotic systems [1–3].

Theoretical background on fractional calculus can be found in [9–11,15,19,22].

Recently, the case, when the order is changing in time, started to be intensively developed. The variable fractional order behavior can be met, for example, in chemistry (when the properties of the system are changing due to chemical reactions), electrochemistry, and other areas. In [20], experimental studies on an electrochemical example of physical fractional variable-order system are presented. In [18], the variable-order equations were used to describe a history of drug expression. Papers [20,31,32,34] present methods of numerical realization of fractional variable-order integrators or differentiators. The fractional variable-order calculus can be also used to obtain variable-order fractional noise [21], and to obtain new control algorithms [12]. Some properties of such systems are presented in [13]. In [29], the variable-order interpretation of the analog realization of fractional orders integrators, realized as domino ladders, was presented. The applications of variable-order derivatives and integrals can be found also in signal processing [22].

The description of the variable-order systems is more complicated than constant-order systems. In the literature [8,33], three general types of variable-order derivative definitions can be found, however, these definitions were given without interpretation and derivation. In [26], the switching scheme, numerically identical to the 2nd type of fractional derivative definition was introduced. This scheme can be used as an interpretation of this type of definition. In [27,28], the recursive definition of variable-order derivative was introduced, and numerical results of comparison to other known definitions were presented.

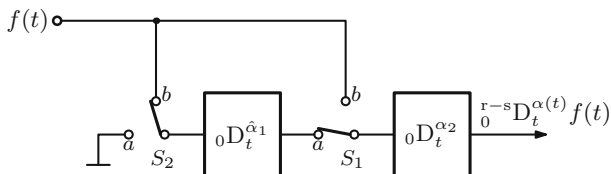
In this work, the switching scheme corresponding to the recursive definition is given and proven. This switching scheme represents an interpretation of the recursive fractional variable-order derivative and exhibits the physical mechanism of order changing characteristic for this type of definition. The matrix approach to the recursive definition is also introduced, and the duality between this new definition and the already well-known 1st type definition of variable-order derivative is established. This property of duality is used in order to prove the main result of this paper, moreover, it constitutes an important result itself. By the duality, we mean the composition property of two types of derivatives, which for the variable-order of the opposite sign yields identity. Equivalence between the reductive-switching strategy and recursive variable-order derivative is tested based on both analog and numerical implementations.

The rest of the paper is organized as follows. Section 2 defines the problem to solve in this work. In Sect. 3, the fractional variable-order Grunwald–Letnikov type derivative definitions are recalled. Section 4 presents some properties of the 1st type of fractional

variable-order derivative definition, which will be useful to develop the main result of the paper. In Sect. 5, a recursive (4th type) definition for variable-order differ-integral is given. Section 6 introduces a matrix form of the recursive type definition of variable-order derivative. The duality between the 1st and 4th type of fractional variable-order derivative definitions is established in Sect. 7. In Sect. 8, the main contribution of this paper, i.e., the identity of the recursive definition to the reductive-switching scheme is presented. Numerical verification of the equivalence between switching-order scheme and 4th type derivative is presented in Sect. 9. Finally, in Sect. 10, an analog realization of the fractional variable-order integral, according to the proposed type of derivative, is presented.

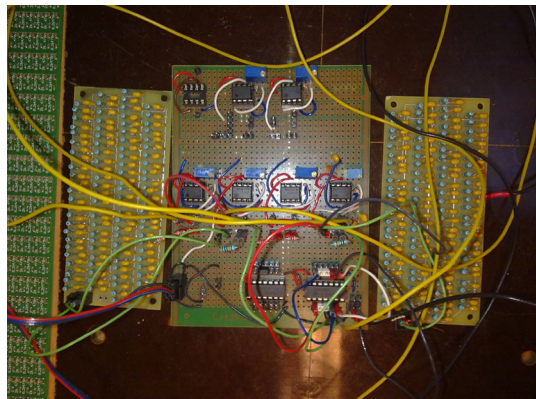
## 2 Problem Statement

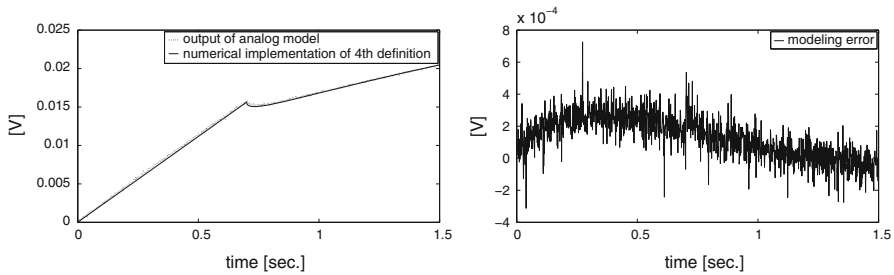
We have build the electrical circuit (see Fig. 2) that realizes the reductive-switching scheme (more details in Sect. 10). The reductive-switching order occurs when the initial chain of derivatives is reduced according to changing the variable-order (more details are presented in Sect. 8). This switching scheme assumes that changing order is obtained by reducing chain of integrators from the input side. The simple reductive-switching case (with only one switch, i.e., one change of order) is presented in Fig. 1.



**Fig. 1** Structure of simple reductive-switching order derivative  ${}_0^r\text{-s}D_t^{\alpha(t)} f(t)$  (switching from  $\alpha_1$  to  $\alpha_2$ ; configuration before switch)

**Fig. 2** Analog implementation of the reductive-switching scheme given by Fig. 1





**Fig. 3** Results (left) of analog (Fig. 2) and numerical formula (1) implementation, and their modeling error (right) of the switching between orders  $\alpha = -1$  and  $\alpha = -0.5$  (see Example 7)

## 2.1 Observation

Let us assume the following, given by formula (1), description of the fractional variable-order derivative (more details about the origin and properties of this formula are given in Sect. 5)

$${}^{\mathcal{D}}D_t^{\alpha(t)} f(t) = \lim_{h \rightarrow 0} \left( \frac{f(t)}{h^{\alpha(t)}} - \sum_{j=1}^n (-1)^j \binom{-\alpha(t)}{j} {}^{\mathcal{D}}D_{t-jh}^{\alpha(t)} f(t) \right). \quad (1)$$

The experimental results compared to numerical implementation of formula (1) are presented in Fig. 3.

**Observation** The formula given by (1) is able to describe with very high accuracy the reductive-switching behavior of the electrical circuit.

**Problem formulation** The problem that will be solved in this work, is to prove that the formula given by (1) is equivalent to the reductive-switching scheme, and to validate these phenomena using experimental electrical circuits.

In order to prove the above stated problem, we present below the required background from fractional calculus and introduce necessary properties of recursive fractional variable-order derivative.

## 3 Fractional Variable-Order Grunwald–Letnikov Type Derivatives

As a base of generalization of the constant fractional order  $\alpha \in \mathbb{R}$  derivative onto variable-order case, the following definition is taken into consideration:

$${}_0D_t^\alpha f(t) = \lim_{h \rightarrow 0} \frac{1}{h^\alpha} \sum_{r=0}^n (-1)^r \binom{\alpha}{r} f(t - rh), \quad (2)$$

where  $h > 0$  is a step time, and  $n = \lfloor t/h \rfloor$ .

The matrix form of the fractional order derivative is given as follows [16, 17]:

$$\begin{pmatrix} {}_0D_0^\alpha f(t) \\ {}_0D_h^\alpha f(t) \\ {}_0D_{2h}^\alpha f(t) \\ \vdots \\ {}_0D_{kh}^\alpha f(t) \end{pmatrix} = \lim_{h \rightarrow 0} W(\alpha, k) \begin{pmatrix} f(0) \\ f(h) \\ f(2h) \\ \vdots \\ f(kh) \end{pmatrix}, \tag{3}$$

where

$$W(\alpha, k) = \begin{pmatrix} h^{-\alpha} & 0 & 0 & \dots & 0 \\ w_{\alpha,1} & h^{-\alpha} & 0 & \dots & 0 \\ w_{\alpha,2} & w_{\alpha,1} & h^{-\alpha} & \dots & 0 \\ w_{\alpha,3} & w_{\alpha,2} & w_{\alpha,1} & \dots & 0 \\ \vdots & \vdots & \vdots & \dots & \vdots \\ w_{\alpha,k} & w_{\alpha,k-1} & w_{\alpha,k-2} & \dots & h^{-\alpha} \end{pmatrix}, \tag{4}$$

$W(\alpha, k) \in \mathbb{R}^{(k+1) \times (k+1)}$ ,  $w_{\alpha,i} = \frac{(-1)^i \binom{\alpha}{i}}{h^\alpha}$ , and  $h = t/k$ ,  $k$  is the number of samples.

For the case of order changing with time (variable-order case), three types of definitions can be found in the literature [8, 33]. The first one is obtained by replacing in (2) a constant-order  $\alpha$  by variable-order  $\alpha(t)$ . In that approach, all coefficients for past samples are obtained for present value of the order, and is given as follows:

**Definition 1** The 1st type of fractional variable-order derivative is defined as follows:

$${}^A_0D_t^{\alpha(t)} f(t) = \lim_{h \rightarrow 0} \frac{1}{h^{\alpha(t)}} \sum_{r=0}^n (-1)^r \binom{\alpha(t)}{r} f(t - rh).$$

The second type of definition assumes that coefficients for past samples are obtained for order that was present for these samples. Identity of this definition to the particular (additive) switching scheme was presented in [26]. In this case, the definition has the following form:

**Definition 2** The 2nd type of fractional variable-order derivative is defined as follows:

$${}^B_0D_t^{\alpha(t)} f(t) = \lim_{h \rightarrow 0} \sum_{r=0}^n \frac{(-1)^r}{h^{\alpha(t-rh)}} \binom{\alpha(t-rh)}{r} f(t - rh).$$

The third definition is less intuitive and assumes that coefficients for the newest samples are obtained, respectively, for the oldest orders. For such a case, the following definition applies:

**Definition 3** The 3rd type of fractional variable-order derivative is defined as:

$${}^C_0D_t^{\alpha(t)} f(t) = \lim_{h \rightarrow 0} \sum_{r=0}^n \frac{(-1)^r}{h^{\alpha(rh)}} \binom{\alpha(rh)}{r} f(t - rh).$$

#### 4 Some Properties of the 1st Type of Fractional Variable-Order Derivative

In order to prove the main result of this paper, i.e., the equivalence of the matrix form of the 4th type of variable-order fractional derivative and the reductive-switching scheme, we give the following additional results, which themselves state new contributions in this research area.

##### 4.1 Matrix Approach of the 1st Type of Derivative

The matrix form of the 1st type of fractional-variable order derivative is given by [30]

$$\begin{pmatrix} {}^A_0D_0^{\alpha(t)} f(t) \\ {}^A_0D_h^{\alpha(t)} f(t) \\ {}^A_0D_{2h}^{\alpha(t)} f(t) \\ \vdots \\ {}^A_0D_{kh}^{\alpha(t)} f(t) \end{pmatrix} = \lim_{h \rightarrow 0} {}^AW(\alpha, k) \begin{pmatrix} f(0) \\ f(h) \\ f(2h) \\ \vdots \\ f(kh) \end{pmatrix}, \quad (5)$$

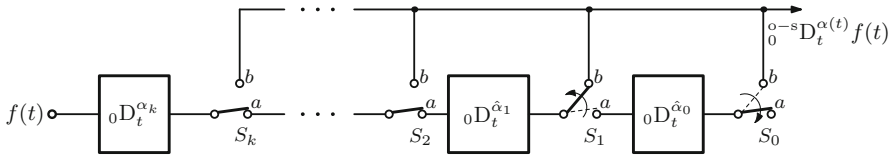
where

$${}^AW(\alpha, k) = \begin{pmatrix} h^{-\alpha(0)} & 0 & 0 & \dots & 0 \\ w_{\alpha(h),1} & h^{-\alpha(h)} & 0 & \dots & 0 \\ w_{\alpha(2h),2} & w_{\alpha(2h),1} & h^{-\alpha(2h)} & \dots & 0 \\ w_{\alpha(3h),3} & w_{\alpha(3h),2} & w_{\alpha(3h),1} & \dots & 0 \\ \vdots & \vdots & \vdots & \dots & \vdots \\ w_{\alpha(kh),k} & w_{\alpha(kh),k-1} & w_{\alpha(kh),k-2} & \dots & h^{-\alpha(kh)} \end{pmatrix}. \quad (6)$$

##### 4.2 Proposed Output-Switching Scheme of the 1st Type of Derivative

Let us introduce the following output-switching (o-s) scheme presented in Fig. 4 based on the chain of derivatives blocks related by the following switching rule. The switches  $S_i$ ,  $i = 0, \dots, k$ , take the following positions

$$S_i = \begin{cases} a & \text{for } t \geq (i+1)h, \\ b & \text{for } t \in [0, (i+1)h), \end{cases} \quad i = 0, \dots, k,$$



**Fig. 4** Structure of the multiple output-switching order derivative  ${}^{o-s}D_t^{\alpha(t)} f(t)$  (configuration after switch between orders  $\alpha_0$  and  $\alpha_1$ , i.e., in time  $t \in (0, h)$ )

and the output of such a structure we denote  ${}^{o-s}D_t^{\alpha(t)} f(t)$ .

Based on Fig. 4 we have the following result.

**Lemma 1** *The numerical description of the multiple output-switching scheme, when we switch between orders  $\alpha_0, \dots, \alpha_k$  every  $ih$  time instant, is the following:*

$$\begin{pmatrix} {}^{o-s}D_0^{\alpha(t)} f(t) \\ {}^{o-s}D_h^{\alpha(t)} f(t) \\ \vdots \\ {}^{o-s}D_{kh}^{\alpha(t)} f(t) \end{pmatrix} = \lim_{h \rightarrow 0} \left( \prod_{i=0}^{k-1} M(\hat{\alpha}_i, k, i) \right) W(\alpha_k, k) \begin{pmatrix} f(0) \\ f(h) \\ \vdots \\ f(kh) \end{pmatrix}, \quad (7)$$

where

$$M(\hat{\alpha}_i, k, i) = \begin{pmatrix} W(\hat{\alpha}_i, i) & 0_{i+1, k-i} \\ 0_{k-i, i+1} & I_{k-i, k-i} \end{pmatrix}, \quad \hat{\alpha}_i = \alpha_i - \alpha_{i+1}, \quad i = 0, \dots, k - 1,$$

and

$$\alpha(t) = \begin{cases} \alpha_{i+1} + \hat{\alpha}_i & \text{for } 0 \leq t < (i + 1)h, \\ \alpha_{i+1} & \text{for } t \geq (i + 1)h, \end{cases} \quad i = 0, \dots, k - 1.$$

*Proof* The proof we will start at analysis signals from the input side. The output signal after the  $\alpha_k$  block has the following form:

$$\begin{pmatrix} {}^{o-s}D_0^{\alpha_k} f(t) \\ {}^{o-s}D_h^{\alpha_k} f(t) \\ {}^{o-s}D_{2h}^{\alpha_k} f(t) \\ \vdots \\ {}^{o-s}D_{(k-1)h}^{\alpha_k} f(t) \\ {}^{o-s}D_{kh}^{\alpha_k} f(t) \end{pmatrix} = \lim_{h \rightarrow 0} W(\alpha_k, k) \begin{pmatrix} f(0) \\ f(h) \\ f(2h) \\ \vdots \\ f((k-1)h) \\ f(kh) \end{pmatrix}.$$

The additional block  $\hat{\alpha}_{k-1}$  is connected in whole time despite of time  $k$ , that is why this signal is represented by the matrix  $M(\hat{\alpha}_{k-1}, k, k - 1)$ . At the output of this block,

we obtain derivative of order  $\alpha_{k-1}$  until time  $k$  when the order is equal to  $\alpha_k$ .

$$\begin{pmatrix} {}_0^{\text{o-s}}\mathbf{D}_0^{\alpha_{k-1}} f(t) \\ {}_0^{\text{o-s}}\mathbf{D}_h^{\alpha_{k-1}} f(t) \\ {}_0^{\text{o-s}}\mathbf{D}_{2h}^{\alpha_{k-1}} f(t) \\ \vdots \\ {}_0^{\text{o-s}}\mathbf{D}_{(k-1)h}^{\alpha_{k-1}} f(t) \\ {}_0^{\text{o-s}}\mathbf{D}_{kh}^{\alpha_k} f(t) \end{pmatrix} = \lim_{h \rightarrow 0} M(\hat{\alpha}_{k-1}, k, k-1) \begin{pmatrix} {}_0^{\text{o-s}}\mathbf{D}_0^{\alpha_k} f(t) \\ {}_0^{\text{o-s}}\mathbf{D}_h^{\alpha_k} f(t) \\ {}_0^{\text{o-s}}\mathbf{D}_{2h}^{\alpha_k} f(t) \\ \vdots \\ {}_0^{\text{o-s}}\mathbf{D}_{(k-1)h}^{\alpha_k} f(t) \\ {}_0^{\text{o-s}}\mathbf{D}_{kh}^{\alpha_k} f(t) \end{pmatrix}.$$

Repeating analogously, we get the output signal from the block of derivative  $\hat{\alpha}_1$  in the following form

$$\begin{pmatrix} {}_0^{\text{o-s}}\mathbf{D}_0^{\alpha_1} f(t) \\ {}_0^{\text{o-s}}\mathbf{D}_h^{\alpha_1} f(t) \\ {}_0^{\text{o-s}}\mathbf{D}_{2h}^{\alpha_2} f(t) \\ \vdots \\ {}_0^{\text{o-s}}\mathbf{D}_{(k-1)h}^{\alpha_{k-1}} f(t) \\ {}_0^{\text{o-s}}\mathbf{D}_{kh}^{\alpha_k} f(t) \end{pmatrix} = \lim_{h \rightarrow 0} M(\hat{\alpha}_1, k, 1) \begin{pmatrix} {}_0^{\text{o-s}}\mathbf{D}_0^{\alpha_2} f(t) \\ {}_0^{\text{o-s}}\mathbf{D}_h^{\alpha_2} f(t) \\ {}_0^{\text{o-s}}\mathbf{D}_{2h}^{\alpha_2} f(t) \\ \vdots \\ {}_0^{\text{o-s}}\mathbf{D}_{(k-1)h}^{\alpha_{k-1}} f(t) \\ {}_0^{\text{o-s}}\mathbf{D}_{kh}^{\alpha_k} f(t) \end{pmatrix}.$$

Finally, we obtain the output signal from the block of derivative  $\hat{\alpha}_0$  in the following form:

$$\begin{pmatrix} {}_0^{\text{o-s}}\mathbf{D}_0^{\alpha_0} f(t) \\ {}_0^{\text{o-s}}\mathbf{D}_h^{\alpha_1} f(t) \\ \vdots \\ {}_0^{\text{o-s}}\mathbf{D}_{(k-1)h}^{\alpha_{k-1}} f(t) \\ {}_0^{\text{o-s}}\mathbf{D}_{kh}^{\alpha_k} f(t) \end{pmatrix} = \lim_{h \rightarrow 0} M(\hat{\alpha}_0, k, 0) \begin{pmatrix} {}_0^{\text{o-s}}\mathbf{D}_0^{\alpha_1} f(t) \\ {}_0^{\text{o-s}}\mathbf{D}_h^{\alpha_1} f(t) \\ \vdots \\ {}_0^{\text{o-s}}\mathbf{D}_{(k-1)h}^{\alpha_{k-1}} f(t) \\ {}_0^{\text{o-s}}\mathbf{D}_{kh}^{\alpha_k} f(t) \end{pmatrix}.$$

Combining all this together, we get (7), completing the proof.  $\square$

**Theorem 1** Matrix approach of the 1st type derivative given by (5) is equivalent to the output-switching scheme given by (7), i.e.,

$${}_0^A\mathbf{D}_t^{\alpha(t)} f(t) \equiv {}_0^{\text{o-s}}\mathbf{D}_t^{\alpha(t)} f(t).$$

*Proof* For simplicity, let us assume the case of one switch between orders, say  $\alpha_1$  and  $\alpha_2$  occurring at time  $T = \tau h$ ,  $\tau \in \mathbb{N}_+$ , we have the following matrix form based on



Lemma 1:

$$\begin{pmatrix} {}_0^{\text{o-s}}D_0^{\alpha(t)} f(t) \\ \vdots \\ {}_0^{\text{o-s}}D_T^{\alpha(t)} f(t) \\ \vdots \\ {}_0^{\text{o-s}}D_{kh}^{\alpha(t)} f(t) \end{pmatrix} = \lim_{h \rightarrow 0} M(\hat{\alpha}_1, k, \tau - 1)W(\alpha_2, k) \begin{pmatrix} f(0) \\ \vdots \\ f(T) \\ \vdots \\ f(kh) \end{pmatrix}, \tag{8}$$

where

$$M(\hat{\alpha}_1, k, \tau - 1) = \begin{pmatrix} W(\hat{\alpha}_1, \tau - 1) & 0_{\tau, k-\tau+1} \\ 0_{k-\tau+1, \tau} & I_{k-\tau+1, k-\tau+1} \end{pmatrix}, \quad \hat{\alpha}_1 = \alpha_1 - \alpha_2,$$

and

$$\alpha(t) = \begin{cases} \alpha_2 + \hat{\alpha}_1 & \text{for } t < T, \\ \alpha_2 & \text{for } t \geq T. \end{cases}$$

The matrix product

$$\begin{aligned} M(\hat{\alpha}_1, k, \tau - 1)W(\alpha_2, k) &= \begin{pmatrix} W(\hat{\alpha}_1, \tau - 1) & 0_{\tau, k-\tau+1} \\ 0_{k-\tau+1, \tau} & I_{k-\tau+1, k-\tau+1} \end{pmatrix} \begin{pmatrix} W(\alpha_2, \tau - 1) & 0_{\tau, k-\tau+1} \\ A(\alpha_2) & B(\alpha_2) \end{pmatrix} \\ &= \begin{pmatrix} W(\hat{\alpha}_1 + \alpha_2, \tau - 1) & 0_{\tau, k-\tau+1} \\ A(\alpha_2) & B(\alpha_2) \end{pmatrix} \\ &= \begin{pmatrix} W(\alpha_1, \tau - 1) & 0_{\tau, k-\tau+1} \\ A(\alpha_2) & B(\alpha_2) \end{pmatrix}, \end{aligned}$$

where  $A(\alpha_2) \in \mathbb{R}^{(k-\tau+1) \times \tau}$  and  $B(\alpha_2) \in \mathbb{R}^{(k-\tau+1) \times (k-\tau+1)}$  are suitable sub-matrices of  $W(\alpha_2, k)$ , obviously corresponds to  ${}^A W(\alpha, k)$  given by (6) for

$$\alpha = \alpha(t) = \begin{cases} \alpha_1 & \text{for } t < T, \\ \alpha_2 & \text{for } t \geq T, \end{cases}$$

i.e., in (6) we have  $\alpha(ih) = \alpha_1$  for  $i = 0, \dots, \tau - 1$ , and  $\alpha(jh) = \alpha_2$  for  $j = \tau, \dots, k$ . The prove of multiple-switching case can be obtained by simple analogy to the proof of one switching case. □

### 5 Recursive Definition for Variable-Order Differ-Integral

The fractional constant-order difference definition (that can be obtained from Definition 1 for  $\alpha(t) = \text{const}$ ) can be rewritten as follows [27]:

$$\Delta_x^n(z) = \left( \frac{1 - z^{-1}}{h} \right)^\alpha X(z),$$

where  $\Delta_x^n(z)$  being Z-transform of the signal difference of order  $\alpha$  of variable  $x(t)$ . It can be also rewritten as

$$\Delta_x^n(z) = \frac{h^{-\alpha}}{(1 - z^{-1})^\alpha} X(z),$$

which gives the following relation

$$\Delta_x^n(z)(1 - z^{-1})^{-\alpha} = h^{-\alpha} X(z),$$

and can be represented in the time domain as

$$\sum_{j=0}^k (-1)^j \binom{-\alpha}{j} \Delta^\alpha x_{k-j} = h^{-\alpha} x_k.$$

Finally, it can be rewritten in the following form

$$\Delta^\alpha x_k = h^{-\alpha} x_k - \sum_{j=1}^k (-1)^j \binom{-\alpha}{j} \Delta^\alpha x_{k-j}.$$

This type of difference is obtained from all values of previous differences. For variable-order case, we can obtain the following definition:

**Definition 4** The 4th type of fractional variable-order difference is defined as follows:

$$\mathcal{D} \Delta^{\alpha_k} x_k = \frac{x_k}{h^{\alpha_k}} - \sum_{j=1}^k (-1)^j \binom{-\alpha_k}{j} \mathcal{D} \Delta^{\alpha_{k-j}} x_{k-j}.$$

For a continuous time domain case, the 4th difference definition can be rewritten in the following form [27].

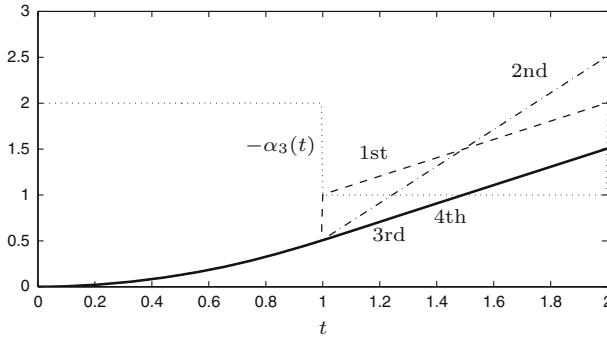
**Definition 5** The 4th type of fractional variable-order derivative is defined as follows:

$${}_0^{\mathcal{D}} \mathcal{D}_t^{\alpha(t)} f(t) = \lim_{h \rightarrow 0} \left( \frac{f(t)}{h^{\alpha(t)}} - \sum_{j=1}^n (-1)^j \binom{-\alpha(t)}{j} {}_0^{\mathcal{D}} \mathcal{D}_{t-jh}^{\alpha(t)} f(t) \right).$$

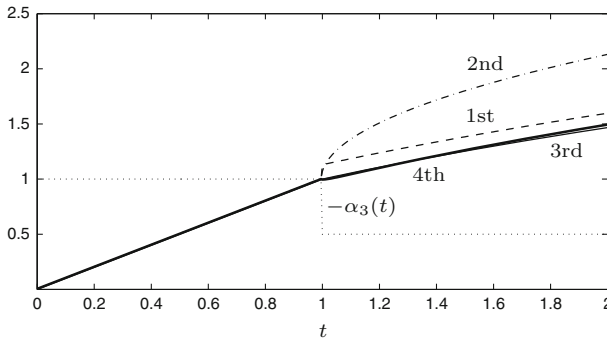
*Remark 1* For a fractional constant-order  $\alpha = \text{const}$ , the fractional derivative given by Definition 5 is numerically identical with constant-order fractional derivative given by (2).

Numerical results of the 4th type derivatives, of variable-order  $\alpha_3(t)$  given by

$$\alpha_3(t) = \begin{cases} \alpha_1 & \text{for } 0 \leq t < 1, \\ \alpha_2 & \text{for } 1 \leq t \leq 2, \end{cases} \quad (9)$$



**Fig. 5** Plots of step function derivatives, for  $\alpha_3(t)$  given by (9), where  $\alpha_1 = -2, \alpha_2 = -1$ , with respect to the definitions: 1st–4th



**Fig. 6** Plots of step function derivatives, for  $\alpha_3(t)$  given by (9), where  $\alpha_1 = -1, \alpha_2 = -0.5$ , with respect to the definitions: 1st–4th

compared to the other types of derivative definitions are presented in Figs. 5, 6, 7 and 8.

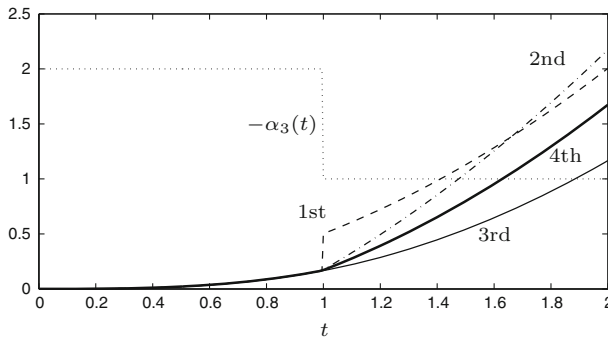
It can be seen from Figs. 5 and 6 that the derivative results in the case of 3rd and 4th type definition, for input signal being Heaviside step function, i.e.,  $f(t) = 1(t)$ , are very near to each-other. It follows from the fact that for the constant signal the sequence of samples is insignificant. However, for the linear input signal  $f(t) = t \cdot 1(t)$ , the difference between these both definitions becomes clearly visible, what is seen in Figs. 7 and 8.

As it can be noticed in Figs. 7 and 8 for the linear input signal the differences between the 4th and others types of derivatives (i.e. 1st, 2nd, and 3rd), are indeed well visible and significant. More plots comparing all the definitions are presented in [27].

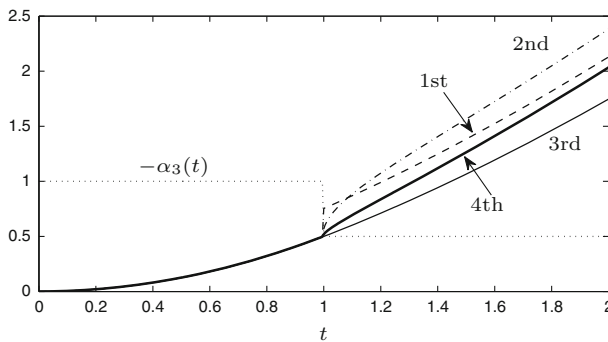
### 6 Matrix Approach for the 4th Type of Fractional Difference Definition

Let us recall the 4th type of variable-order difference definition in the following form:

$$D_{\Delta}^{\alpha_l} x_l = \frac{x_l}{h^{\alpha_l}} - \sum_{j=1}^l (-1)^j \binom{-\alpha_l}{j} D_{\Delta}^{\alpha_l-j} x_{l-j} \tag{10}$$



**Fig. 7** Plots of linear-time function derivatives, for  $\alpha_3(t)$  given by (9), where  $\alpha_1 = -2, \alpha_2 = -1$ , with respect to the derivative definitions: 1st–4th



**Fig. 8** Plots of linear-time function derivatives, for  $\alpha_3(t)$  given by (9), where  $\alpha_1 = -1, \alpha_2 = -0.5$ , with respect to the derivative definitions: 1st–4th

for  $l = 0, 1, 2, \dots, k$ . This definition can be rewritten in the matrix form, what is given by the following lemma:

**Lemma 2** *Fractional difference of 4th type given by Definition 4 can be expressed in the following matrix form:*

$$\begin{pmatrix} \mathcal{D} \Delta^{\alpha_0} x_0 \\ \mathcal{D} \Delta^{\alpha_1} x_1 \\ \mathcal{D} \Delta^{\alpha_2} x_2 \\ \vdots \\ \mathcal{D} \Delta^{\alpha_k} x_k \end{pmatrix} = \mathfrak{Q}_0^k \begin{pmatrix} x_0 \\ x_1 \\ x_2 \\ \vdots \\ x_k \end{pmatrix}, \tag{11}$$

where

$$\mathfrak{Q}_0^k = \mathfrak{Q}(\alpha_k, k) \cdots \mathfrak{Q}(\alpha_1, 1) \mathfrak{Q}(\alpha_0, 0), \tag{12}$$

and

$$\mathfrak{Q}(\alpha_0, 0) = \left( \begin{array}{c|c} h^{-\alpha_0} & 0_{1,k} \\ \hline 0_{k,1} & I_{k,k} \end{array} \right) \in \mathbb{R}^{(k+1) \times (k+1)},$$

and for  $r = 1, \dots, k$

$$\mathfrak{Q}(\alpha_r, r) = \left( \begin{array}{c|c|c} I_{r,r} & 0_{r,1} & 0_{r,k-r} \\ \hline q_r & h^{-\alpha_r} & 0_{1,k-r} \\ \hline 0_{k-r,r} & 0_{k-r,1} & I_{k-r,k-r} \end{array} \right) \in \mathbb{R}^{(k+1) \times (k+1)}, \tag{13}$$

where

$$q_r = (-v_{-\alpha_r,r}, -v_{-\alpha_r,r-1}, \dots, -v_{-\alpha_r,1}) \in \mathbb{R}^{1 \times r},$$

and  $v_{-\alpha_r,i} = (-1)^i \binom{-\alpha_r}{i}$ , for  $i = 1, \dots, r$ , i.e., the  $j$ th element of  $q_r$  is

$$(q_r)_j = -v_{-\alpha_r,r-j+1} = (-1)^{r-j+1} \binom{-\alpha_r}{r-j+1}, \text{ for } j = 1, \dots, r.$$

*Proof* It is obtained after consecutive evaluating (10) for each time step  $l = 0, 1, \dots, k$ . First, for  $l = 0$ , we can write

$$\begin{pmatrix} {}^{\mathcal{D}}\Delta^{\alpha_0} x_0 \\ x_1 \\ x_2 \\ \vdots \\ x_k \end{pmatrix} = \begin{pmatrix} h^{-\alpha_0} x_0 \\ x_1 \\ x_2 \\ \vdots \\ x_k \end{pmatrix} = \underbrace{\begin{pmatrix} h^{-\alpha_0} & 0 & 0 & \dots & 0 \\ 0 & 1 & 0 & \dots & 0 \\ 0 & 0 & 1 & \dots & 0 \\ \vdots & \vdots & \vdots & \dots & \vdots \\ 0 & 0 & 0 & \dots & 0 \\ 0 & 0 & 0 & \dots & 1 \end{pmatrix}}_{\mathfrak{Q}(\alpha_0, 0)} \begin{pmatrix} x_0 \\ x_1 \\ x_2 \\ \vdots \\ x_k \end{pmatrix}.$$

Next, for  $l = 1$ :

$$\begin{pmatrix} \mathcal{D}\Delta^{\alpha_0}x_0 \\ \mathcal{D}\Delta^{\alpha_1}x_1 \\ x_2 \\ \vdots \\ x_k \end{pmatrix} = \underbrace{\begin{pmatrix} 1 & 0 & 0 & \dots & 0 \\ -v_{-\alpha_1,1} & h^{-\alpha_1} & 0 & \dots & 0 \\ 0 & 0 & 1 & \dots & 0 \\ \vdots & \vdots & \vdots & \dots & \vdots \\ 0 & 0 & 0 & \dots & 0 \\ 0 & 0 & 0 & \dots & 1 \end{pmatrix}}_{\Omega(\alpha_1,1)} \begin{pmatrix} \mathcal{D}\Delta^{\alpha_0}x_0 \\ x_1 \\ x_2 \\ \vdots \\ x_k \end{pmatrix};$$

for  $l = 2$ :

$$\begin{pmatrix} \mathcal{D}\Delta^{\alpha_0}x_0 \\ \mathcal{D}\Delta^{\alpha_1}x_1 \\ \mathcal{D}\Delta^{\alpha_2}x_2 \\ x_3 \\ \vdots \\ x_k \end{pmatrix} = \underbrace{\begin{pmatrix} 1 & 0 & 0 & \dots & 0 \\ 0 & 1 & 0 & \dots & 0 \\ -v_{-\alpha_2,2} & -v_{-\alpha_2,1} & h^{-\alpha_2} & \dots & 0 \\ \vdots & \vdots & \vdots & \ddots & \vdots \\ 0 & 0 & 0 & \dots & 1 \end{pmatrix}}_{\Omega(\alpha_2,2)} \begin{pmatrix} \mathcal{D}\Delta^{\alpha_0}x_0 \\ \mathcal{D}\Delta^{\alpha_1}x_1 \\ x_2 \\ \vdots \\ x_k \end{pmatrix};$$

and, generally, for  $l = r$ , we have

$$\begin{pmatrix} \mathcal{D}\Delta^{\alpha_0}x_0 \\ \mathcal{D}\Delta^{\alpha_1}x_1 \\ \vdots \\ \mathcal{D}\Delta^{\alpha_{r-1}}x_{r-1} \\ \mathcal{D}\Delta^{\alpha_r}x_r \\ x_{r+1} \\ \vdots \\ x_k \end{pmatrix} = \underbrace{\begin{pmatrix} I_{r,r} & 0_{r,1} & 0_{r,k-r} \\ q_r & h^{-\alpha_r} & 0_{1,k-r} \\ 0_{k-r,r} & 0_{k-r,1} & I_{k-r,k-r} \end{pmatrix}}_{\Omega(\alpha_r,r)} \begin{pmatrix} \mathcal{D}\Delta^{\alpha_0}x_0 \\ \mathcal{D}\Delta^{\alpha_1}x_1 \\ \vdots \\ \mathcal{D}\Delta^{\alpha_{r-1}}x_{r-1} \\ x_r \\ \vdots \\ x_k \end{pmatrix}.$$

Finally, for  $l = k$ :

$$\begin{pmatrix} \mathcal{D}\Delta^{\alpha_0}x_0 \\ \mathcal{D}\Delta^{\alpha_1}x_1 \\ \vdots \\ \mathcal{D}\Delta^{\alpha_{k-1}}x_{k-1} \\ \mathcal{D}\Delta^{\alpha_k}x_k \end{pmatrix} = \underbrace{\begin{pmatrix} I_{k,k} & 0_{k,1} \\ q_k & h^{-\alpha_k} \end{pmatrix}}_{\Omega(\alpha_k, k)} \begin{pmatrix} \mathcal{D}\Delta^{\alpha_0}x_0 \\ \mathcal{D}\Delta^{\alpha_1}x_1 \\ \vdots \\ \mathcal{D}\Delta^{\alpha_{k-1}}x_{k-1} \\ x_k \end{pmatrix},$$

where  $q_k = (-v_{-\alpha_k, k}, \dots, -v_{-\alpha_k, 1})$ . Combining all this together, completes the proof.  $\square$

*Remark 2* For step time  $h = 1$ , we have  $\Omega(\alpha_0, 0) = I_{k+1, k+1}$ , which implies  $\Omega_0^k = \Omega(\alpha_k, k) \cdots \Omega(\alpha_1, 1)$ .

*Remark 3* From direct multiplication of (13), the following matrix product

$$\Omega_m^n = \Omega(\alpha_n, n) \cdots \Omega(\alpha_m, m), \quad 0 \leq m \leq n \leq k, \tag{14}$$

is given by

$$\Omega_m^n = \left( \begin{array}{c|cc} I_{m,m} & 0_{m, n-m+1} & 0_{m, k-n} \\ \hline q_{m+1,1} \ q_{m+1,2} \ \cdots \ q_{m+1,m} & h^{-\alpha_m} \quad 0 \quad \cdots \quad 0 & \\ q_{m+2,1} \ q_{m+2,2} \ \cdots \ q_{m+2,m} & q_{m+2,m+1} \ h^{-\alpha_{m+1}} \ \cdots \quad 0 & 0_{n-m+1, k-n} \\ \vdots \quad \vdots \quad \vdots \quad \vdots & \vdots \quad \vdots \quad \ddots \quad \vdots & \\ q_{n+1,1} \ q_{n+1,2} \ \cdots \ q_{n+1,m} & q_{n+1,m+1} \ q_{n+1,m+2} \ \cdots \ h^{-\alpha_n} & \\ \hline 0_{k-n, m} & 0_{k-n, n-m+1} & I_{k-n, k-n} \end{array} \right),$$

where

$$q_{i,j} = q_{i-1}(q_{1,j}, \dots, q_{i-1,j})^T, \quad m+1 \leq i \leq n+1, \quad 1 \leq j \leq n, \quad \text{s.t. } i > j. \tag{15}$$

*Example 1* For  $m = 0$  and  $n = k$ , from (3), we get the following matrix

$$\mathfrak{Q}_0^k = \begin{pmatrix} h^{-\alpha_0} & 0 & 0 & \cdots & 0 & 0 \\ \mathfrak{q}_{2,1} & h^{-\alpha_1} & 0 & \cdots & 0 & 0 \\ \mathfrak{q}_{3,1} & \mathfrak{q}_{3,2} & h^{-\alpha_2} & \cdots & 0 & 0 \\ \vdots & \vdots & \vdots & \ddots & \ddots & \vdots \\ \mathfrak{q}_{k,1} & \mathfrak{q}_{k,2} & \mathfrak{q}_{k+1,3} & \cdots & h^{-\alpha_{k-1}} & 0 \\ \mathfrak{q}_{k+1,1} & \mathfrak{q}_{k+1,2} & \mathfrak{q}_{k+1,3} & \cdots & \mathfrak{q}_{k+1,k} & h^{-\alpha_k} \end{pmatrix}, \tag{16}$$

where  $\mathfrak{q}_{i,j}$  for  $1 \leq j < i \leq k + 1$  are given by (15).

*Remark 4* Matrix (3) can be written as

$$\mathfrak{Q}_m^n = \mathfrak{Q}_m^n \cdot \text{diag}\{\underbrace{1, \dots, 1}_{m\text{-times}}, \underbrace{h^{-\alpha_m}, \dots, h^{-\alpha_n}}_{n-m+1\text{-times}}, \underbrace{1, \dots, 1}_{k-n\text{-times}}\}, \tag{17}$$

where

$$\mathfrak{Q}_m^n = \begin{pmatrix} I_{m,m} & 0_{m,n-m+1} & 0_{m,k-n} \\ \mathfrak{q}_{m+1,1} \ \mathfrak{q}_{m+1,2} \ \cdots \ \mathfrak{q}_{m+1,m} & 1 \ 0 \ \cdots \ 0 & \\ \mathfrak{q}_{m+2,1} \ \mathfrak{q}_{m+2,2} \ \cdots \ \mathfrak{q}_{m+2,m} & \mathfrak{q}_{m+2,m+1} \ 1 \ \cdots \ 0 & \\ \vdots \ \vdots \ \vdots \ \vdots & \vdots \ \vdots \ \ddots \ \vdots & \\ \mathfrak{q}_{n+1,1} \ \mathfrak{q}_{n+1,2} \ \cdots \ \mathfrak{q}_{n+1,m} & \mathfrak{q}_{n+1,m+1} \ \mathfrak{q}_{n+1,m+2} \ \cdots \ 1 & \\ 0_{k-n,m} & 0_{k-n,n-m+1} & I_{k-n,k-n} \end{pmatrix}, \tag{18}$$

where

$$\mathfrak{q}_{i,j} = \mathfrak{q}_{i-1}(q_{1,j}, \dots, q_{i-1,j})^T, \quad m + 1 \leq i \leq n + 1, \quad 1 \leq j \leq n, \quad \text{s.t. } i > j.$$

*Example 2* For  $n = m$ , from (3), we get



$$\mathfrak{Q}_m^m = \left( \begin{array}{c|cc} I_{m,m} & 0_{m,1} & 0_{m,k-m} \\ \hline \mathfrak{q}_{m+1,1} \dots \mathfrak{q}_{m+1,m} & h^{-\alpha_m} & 0_{1,k-m} \\ \hline 0_{k-m,m} & 0_{k-m,1} & I_{k-m,k-m} \end{array} \right),$$

where  $\mathfrak{q}_{m+1,i} = (q_m)_i$  for  $i = 1, \dots, m$ . Then, we obtain

$$\begin{aligned} \mathfrak{Q}_m^m &= \left( \begin{array}{c|cc} I_{m,m} & 0_{m,1} & 0_{m,k-m} \\ \hline q_m & h^{-\alpha_m} & 0_{1,k-m} \\ \hline 0_{k-m,m} & 0_{k-m,1} & I_{k-m,k-m} \end{array} \right) \\ &= \underbrace{\left( \begin{array}{c|cc} I_{m,m} & 0_{m,1} & 0_{m,k-m} \\ \hline q_m & 1 & 0_{1,k-m} \\ \hline 0_{k-m,m} & 0_{k-m,1} & I_{k-m,k-m} \end{array} \right)}_{Q_m^m} \text{diag}\{\underbrace{1, \dots, 1}_{m\text{-times}}, h^{-\alpha_m}, 1, \dots, 1\}, \end{aligned} \tag{19}$$

which matches to  $\mathfrak{Q}(\alpha_r, r)$  given by (13) for  $m = r$ .

*Remark 5* The entries  $q_{i,j}$  and  $q_{i,j}$  of (3) and (18), respectively, are equal to each other, for  $i = m + 1, \dots, n + 1$  and  $j = 1, \dots, m$ , i.e.,  $q_{i,j} = q_{i,j}$ . Moreover, matrix  $Q_m^n$  does not depend on  $h$ .

*Example 3* For  $k = 4, m = 1$ , and  $n = 2$ , using (14) or (3), we get

$$\mathfrak{Q}_1^2 = \left( \begin{array}{ccccc} 1 & 0 & 0 & 0 & 0 \\ (q_1)_1 & h^{-\alpha_1} & 0 & 0 & 0 \\ (q_1)_1(q_2)_2 + (q_2)_1 & (q_2)_2 h^{-\alpha_1} & h^{-\alpha_2} & 0 & 0 \\ 0 & 0 & 0 & 1 & 0 \\ 0 & 0 & 0 & 0 & 1 \end{array} \right),$$

where  $(q_i)_j$  stands for  $j$ th entries of vector  $q_i$ . More precisely, it is given by

$$\mathfrak{Q}_1^2 = \left( \begin{array}{ccccc} 1 & 0 & 0 & 0 & 0 \\ -v_{-\alpha_1,1} & h^{-\alpha_1} & 0 & 0 & 0 \\ v_{-\alpha_1,1}v_{-\alpha_2,1} - v_{-\alpha_2,2} & -v_{-\alpha_2,1}h^{-\alpha_1} & h^{-\alpha_2} & 0 & 0 \\ 0 & 0 & 0 & 1 & 0 \\ 0 & 0 & 0 & 0 & 1 \end{array} \right).$$

**Remark 6** A natural extension of the above considerations (by taking the limit  $h \rightarrow 0$ ), is the following form of the 4th type of variable-order derivative definition:

$$\begin{pmatrix} {}^{\mathcal{D}}_0 D_0^{\alpha(t)} f(t) \\ {}^{\mathcal{D}}_0 D_h^{\alpha(t)} f(t) \\ {}^{\mathcal{D}}_0 D_{2h}^{\alpha(t)} f(t) \\ \vdots \\ {}^{\mathcal{D}}_0 D_{kh}^{\alpha(t)} f(t) \end{pmatrix} = \lim_{h \rightarrow 0} \mathfrak{Q}_0^k \begin{pmatrix} f(0) \\ f(h) \\ f(2h) \\ \vdots \\ f(kh) \end{pmatrix}, \quad (20)$$

where  $\mathfrak{Q}_0^k$  is given by (12).

## 7 Duality Between the 1st and 4th Type of Fractional Variable-Order Derivatives

In this section, we present the duality between the 1st and 4th type of fractional variable-order derivatives, which will be used to derive the main result of this paper, i.e., the equivalence of the 4th definition and the multiple reductive-switching case. By the duality, we mean the composition property of two types of derivatives, which for the variable-order of the opposite signs yields identity. The duality property, constitutes also an important value itself in the fractional calculus domain.

**Lemma 3** *The inverse of  $\mathfrak{Q}_m^n$  is*

$$(\mathfrak{Q}_m^n)^{-1} = \left( \begin{array}{c|c|c} I_{m,m} & 0_{m,n-m+1} & 0_{m,k-n} \\ \hline \hat{\mathfrak{Q}}_{21} & \hat{\mathfrak{Q}}_{22} & 0_{n-m+1,k-n} \\ \hline 0_{k-n,m} & 0_{k-n,n-m+1} & I_{k-n,k-n} \end{array} \right), \quad (21)$$

where

$$\hat{\mathfrak{Q}}_{21} = \begin{pmatrix} -(q_m)_1 h^{\alpha_m} & \dots & -(q_m)_m h^{\alpha_m} \\ -(q_{m+1})_1 h^{\alpha_{m+1}} & \dots & -(q_{m+1})_m h^{\alpha_{m+1}} \\ \vdots & \vdots & \vdots \\ -(q_n)_1 h^{\alpha_n} & \dots & -(q_n)_m h^{\alpha_n} \end{pmatrix},$$

$$\hat{\Omega}_{22} = \begin{pmatrix} h^{\alpha_m} & 0 & \dots & 0 \\ -(q_{m+1})_{m+1}h^{\alpha_{m+1}} & h^{\alpha_{m+1}} & \dots & 0 \\ \vdots & \ddots & \vdots & \vdots \\ -(q_n)_{m+1}h^{\alpha_n} & -(q_n)_{m+2}h^{\alpha_n} & \dots & h^{\alpha_n} \end{pmatrix},$$

or

$$(\Omega_m^n)^{-1} = \text{diag}\{\underbrace{1, \dots, 1}_{m\text{-times}}, \underbrace{h^{\alpha_m}, \dots, h^{\alpha_n}}_{n-m+1\text{-times}}, \underbrace{1, \dots, 1}_{k-n\text{-times}}\} \underbrace{\begin{pmatrix} I_{m,m} & 0_{m,n-m+1} & 0_{m,k-n} \\ \hline \bar{q}_m & & \\ \vdots & & 0_{n-m+1,k-n} \\ \bar{q}_n & & \\ \hline 0_{k-n,n+1} & I_{k-n,k-n} \end{pmatrix}}_{\bar{Q}_m^n}, \tag{22}$$

where

$$\bar{q}_i = (-q_i, \underbrace{1, 0, \dots, 0}_{n-i\text{-times}}) \in \mathbb{R}^{1 \times (n+1)}, \quad i = 1, \dots, k; \quad \bar{q}_0 = (1, \underbrace{0, \dots, 0}_{n\text{-times}}) \in \mathbb{R}^{1 \times (n+1)}. \tag{23}$$

*Proof* We will show that the product of matrices  $(\Omega_m^n)^{-1}$  and  $\Omega_m^n$  given by (22) and (17), respectively, is an identity, i.e.,  $(\Omega_m^n)^{-1} \Omega_m^n = I_{k+1,k+1}$ . Let us calculate

$$(\Omega_m^n)^{-1} \Omega_m^n = \bar{D} \bar{Q}_m^n Q_m^n D,$$

where  $\bar{D}$  and  $D$  are the diagonal matrices given in (22) and (17), respectively. Then, we have to show that  $\bar{Q}_m^n Q_m^n = I_{k+1,k+1}$ , because, obviously  $\bar{D}D = I_{k+1,k+1}$ . Denote by  $(\bar{Q}_m^n)^i$  the  $i$ th row of  $\bar{Q}_m^n$ , and by  $(Q_m^n)_j$  the  $j$ th column of  $Q_m^n$ . Then, one has to calculate

$$(\bar{Q}_m^n)^i (Q_m^n)_j = (-q_{i-1})_j + \sum_{p=m+1}^{i-1} (-q_{i-1})_p q_{p,j} + q_{i,j} \tag{24}$$

for  $i = m + 1, \dots, n$  and  $j = 1, \dots, m$ . From (18) and (15), the straightforward calculation gives

$$q_{i,j} = (q_{i-1})_j + \sum_{p=m+1}^{i-1} (q_{i-1})_p q_{p,j} \quad \text{for } i = m + 1, \dots, n; \quad j = 1, \dots, m. \tag{25}$$

Substituting (25) to (24), we get  $(\bar{Q}_m^n)^i(Q_m^n)_j = 0$  for  $i = m + 1, \dots, n$  and  $j = 1, \dots, m$ .

Similarly, for  $i = m + 1, \dots, n$  and  $j = m + 1, \dots, n + 1$ , and  $i \geq j$ , we have

$$(\bar{Q}_m^n)^i(Q_m^n)_j = (-q_{i-1})_j + \sum_{p=j+1}^{i-1} (-q_{i-1})_p q_{p,j} + q_{i,j}. \tag{26}$$

Because from (26), for  $i = j$ , we obtain  $(\bar{Q}_m^n)^i(Q_m^n)_i = q_{i,i}$ , and  $q_{i,i} = 1$ , then  $(\bar{Q}_m^n)^i(Q_m^n)_i = 1$ . Since for  $i > j$  from (18) and (15) we have

$$q_{i,j} = (q_{i-1})_j + \sum_{p=j+1}^{i-1} (q_{i-1})_p q_{p,j}, \tag{27}$$

after substituting (27) into (26), we get  $(\bar{Q}_m^n)^i(Q_m^n)_j = 0$ . The case, for  $i = m + 1, \dots, n$  and  $j = m + 1, \dots, n + 1$ , where  $i < j$ , is obvious, i.e.,  $(\bar{Q}_m^n)^i(Q_m^n)_j = 0$ . The other subblock multiplications are evident, so the proof is finished.  $\square$

*Example 4* Using (21) and (22), the inverse of  $\Omega_0^k$  is

$$(\Omega_0^k)^{-1} = \begin{pmatrix} h^{\alpha_0} & 0 & 0 & \dots & 0 & 0 \\ -(q_1)_1 h^{\alpha_1} & h^{\alpha_1} & 0 & \dots & 0 & 0 \\ -(q_2)_1 h^{\alpha_2} & -(q_2)_2 h^{\alpha_2} & h^{\alpha_2} & \dots & 0 & 0 \\ \vdots & \vdots & \vdots & \vdots & \ddots & \vdots \\ -(q_k)_1 h^{\alpha_k} & -(q_k)_2 h^{\alpha_k} & -(q_k)_3 h^{\alpha_k} & \dots & -(q_k)_k h^{\alpha_k} & h^{\alpha_k} \end{pmatrix}, \tag{28}$$

or

$$(\Omega_0^k)^{-1} = \text{diag}\{h^{\alpha_0}, \dots, h^{\alpha_k}\} \underbrace{\begin{pmatrix} \bar{q}_0 \\ \bar{q}_1 \\ \vdots \\ \bar{q}_k \end{pmatrix}}_{\bar{Q}_0^k},$$

where  $\bar{q}_i, 0 \leq i \leq k$ , are given by (23).

*Example 5* For  $n = m$ , from (22) we get

$$\begin{aligned}
 (\Omega_m^m)^{-1} &= \left( \begin{array}{c|c|c} I_{m,m} & 0_{m,1} & 0_{m,k-m} \\ \hline -h^{\alpha_m} q_m & h^{\alpha_m} & 0_{1,k-m} \\ \hline 0_{k-m,m} & 0_{k-m,1} & I_{k-m,k-m} \end{array} \right) \\
 &= \text{diag} \left\{ \underbrace{1, \dots, 1}_{m\text{-times}}, h^{\alpha_m}, \underbrace{1, \dots, 1}_{k-m\text{-times}} \right\} \underbrace{\left( \begin{array}{c|c|c} I_{m,m} & 0_{m,1} & 0_{m,k-m} \\ \hline -q_m & 1 & 0_{1,k-m} \\ \hline 0_{k-m,m} & 0_{k-m,1} & I_{k-m,k-m} \end{array} \right)}_{(Q_m^m)^{-1}},
 \end{aligned}$$

which is indeed the inverse of (19).

*Remark 7* Because the structures of the matrices  $\Omega_0^k$  and  $(\Omega_0^k)^{-1}$  are different, in the sense that in the first case each entry of the same column, say  $i$ th, is multiplied by the same term  $h^{-\alpha_{i-1}}$ ,  $i = 1, \dots, k + 1$ , and in the second case each entries of the same row, say  $j$ th, is multiplied by the same term  $h^{\alpha_{j-1}}$ ,  $j = 1, \dots, k + 1$ , the following, in general, occurs

$$(\Omega_0^k)^{-1}(\tilde{\alpha}) \neq \Omega_0^k(-\tilde{\alpha}),$$

which implies

$$\mathcal{D}_{\Delta}^{-\tilde{\alpha}} \left( \mathcal{D}_{\Delta}^{\tilde{\alpha}} x_k \right) \neq x_k \quad \text{and} \quad \mathcal{D}_0^{-\alpha(t)} \left( \mathcal{D}_0^{\alpha(t)} f(t) \right) \neq f(t),$$

where  $\tilde{\alpha} = \{\alpha_0, \dots, \alpha_k\}$ . It means that for a variable-order difference (derivative) the semigroup property does not hold. However, for a constant-order, i.e.,  $\alpha_0 = \dots = \alpha_k$ , and, respectively,  $\alpha(t) = \text{const}$ , this property holds.

Let us recall the definition of the fractional variable-order difference of the 1st type:

$${}^A\Delta^{-\alpha_l} y_l = \frac{1}{h^{-\alpha_l}} \sum_{r=0}^l (-1)^r \binom{-\alpha_l}{r} y(l - rh). \tag{29}$$

**Lemma 4** The inverse matrix  $(\mathfrak{Q}_0^k)^{-1}$  with orders  $\{\alpha_0, \dots, \alpha_k\}$  defines the 1st type of variable-order difference definition for orders  $\{-\alpha_0, \dots, -\alpha_k\}$ , i.e.,

$$\begin{pmatrix} {}^A\Delta^{-\alpha_0} y_0 \\ {}^A\Delta^{-\alpha_1} y_1 \\ {}^A\Delta^{-\alpha_2} y_2 \\ \vdots \\ {}^A\Delta^{-\alpha_k} y_k \end{pmatrix} = (\mathfrak{Q}_0^k)^{-1} \begin{pmatrix} y_0 \\ y_1 \\ y_2 \\ \vdots \\ y_k \end{pmatrix}, \tag{30}$$

where  $y_i = {}^D \Delta^{\alpha_i} x_i$ , for  $i = 0, \dots, k$ .

*Proof* It is sufficient to show that  $(\mathfrak{Q}_0^k)^{-1} y$  defines the 1st type of definition given by (29), i.e., it corresponds to the right-hand side of (29). Let us denote by  $(\mathfrak{Q}_0^k)_i^{-1}$  the  $i$ th row of matrix  $(\mathfrak{Q}_0^k)^{-1}$ . Then, from (28), we get

$$\begin{aligned} (\mathfrak{Q}_0^k)_1^{-1} y &= \frac{y_0}{h^{-\alpha_0}} \\ (\mathfrak{Q}_0^k)_2^{-1} y &= -(q_1)_1 h^{\alpha_1} y_0 + h^{\alpha_0} y_1 \\ &= -\frac{y_0}{h^{-\alpha_1}} \begin{pmatrix} -\alpha_1 \\ 1 \end{pmatrix} + \frac{y_1}{h^{-\alpha_1}} \\ &\vdots \\ (\mathfrak{Q}_0^k)_k^{-1} y &= -(q_k)_1 h^{\alpha_k} y_0 - (q_k)_2 h^{\alpha_k} y_1 - \dots - (q_k)_k h^{\alpha_k} y_{k-1} + h^{\alpha_k} y_k \\ &= \frac{(-1)^k y_0}{h^{-\alpha_k}} \begin{pmatrix} -\alpha_k \\ k \end{pmatrix} + \frac{(-1)^{k-1} y_1}{h^{-\alpha_k}} \begin{pmatrix} -\alpha_k \\ k-1 \end{pmatrix} - \frac{y_{k-1}}{h^{-\alpha_k}} \begin{pmatrix} -\alpha_k \\ 1 \end{pmatrix} + \frac{y_k}{h^{-\alpha_k}}. \end{aligned}$$

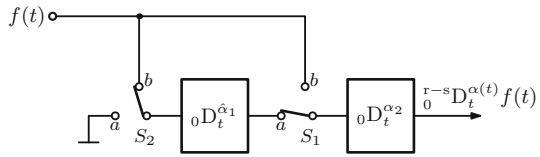
In general, for any  $0 \leq i \leq k$ , we get

$$\begin{aligned} (\mathfrak{Q}_0^k)_i^{-1} y &= -(q_i)_1 h^{\alpha_i} y_0 - (q_i)_2 h^{\alpha_i} y_1 - \dots - (q_i)_i h^{\alpha_i} y_{i-1} + h^{\alpha_i} y_i \\ &= \frac{(-1)^i}{h^{-\alpha_i}} \begin{pmatrix} -\alpha_i \\ i \end{pmatrix} y_0 + \frac{(-1)^{i-1}}{h^{-\alpha_i}} \begin{pmatrix} -\alpha_i \\ i-1 \end{pmatrix} y_1 - \frac{y_{i-1}}{h^{-\alpha_i}} \begin{pmatrix} -\alpha_i \\ 1 \end{pmatrix} + \frac{y_i}{h^{-\alpha_i}} \\ &= \frac{1}{h^{-\alpha_i}} \sum_{r=0}^i (-1)^r \binom{-\alpha_i}{r} y(i-rh), \end{aligned}$$

which shows the desired equivalence, i.e.,  $(\mathfrak{Q}_0^k)_i^{-1} y = {}^A \Delta^{-\alpha_i} y_i$ , for  $0 \leq i \leq k$ .

The same can also be proved by comparing matrix  $(\mathfrak{Q}_0^k)^{-1}$  with the matrix  ${}^A W(\alpha, k)$  defining the 1st derivative definition (see [30]). □

**Fig. 9** Structure of simple reductive-switching order derivative  ${}^{r-s}D_t^{\alpha(t)} f(t)$  (switching from  $\alpha_1$  to  $\alpha_2$ ; configuration before time  $T$ )



*Remark 8* Obviously, since (30) holds, the following is also true

$$\begin{pmatrix} {}^A_0D_0^{-\alpha(t)} y(t) \\ {}^A_0D_h^{-\alpha(t)} y(t) \\ \vdots \\ {}^A_0D_{kh}^{-\alpha(t)} y(t) \end{pmatrix} = \lim_{h \rightarrow 0} (\mathfrak{Q}_0^k)^{-1} \begin{pmatrix} y(0) \\ y(h) \\ \vdots \\ y(kh) \end{pmatrix},$$

where  $y(ih) = {}^A_0D_{ih}^{\alpha(t)} f(t)$ , for  $i = 0, \dots, k$ .

**Theorem 2** *The following dualities hold*

$${}^A\Delta^{-\tilde{\alpha}} \left( {}^D\Delta^{\tilde{\alpha}} x_k \right) = x_k \quad \text{and} \quad {}^A_0D_t^{-\alpha(t)} \left( {}^D_0D_t^{\alpha(t)} f(t) \right) = f(t),$$

where  $\tilde{\alpha} = \{\alpha_0, \dots, \alpha_k\}$ .

*Proof* In both cases, i.e., in the difference and derivative case, it simply follows from the composition of matrices  $(\mathfrak{Q}_0^k)^{-1}$  and  $\mathfrak{Q}_0^k$ , which obviously yields identity.  $\square$

### 8 Main Result—Equivalence of Reductive-Switching Order Case

In this section, the equivalence between the reductive-switching scheme and the 4th type of fractional variable-order derivative definition will be presented, for clarity and simplicity, in two parts, namely, in the case of simple (one) switching, and later in the general case—multiple switching.

#### 8.1 Simple Reductive-Switching Order Case

The reductive-switching (r-s) order case occurs when the initial chain of derivatives is reduced according to changing the variable-order.

The idea, introduced in [30], is depicted in Fig. 9, where the switches  $S_i, i = 1, 2$ , change their positions depending on an actual value of  $\alpha(t)$ . If we want to switch from  $\alpha_1$  to  $\alpha_2$ , then, before switching time  $T$ , we have:  $S_1 = a, S_2 = b$ , and after this time:  $S_1 = b$  and  $S_2 = a$ . At the instant time  $T$ , the derivative block of complementary order  $\hat{\alpha}_1$  is disconnected from the front of the derivative block of order  $\alpha_2$ , where

$$\hat{\alpha}_1 = \alpha_1 - \alpha_2. \tag{31}$$

The numerical scheme for reductive-switching case can be obtained similarly to additive-switching scheme (see details in [30]).

**Lemma 5** [30] *For a reductive-switching order case, when the switch from order  $\alpha_1$  to order  $\alpha_2$  occurs at time  $T = \tau h$ ,  $\tau \in \mathbb{N}_+$ , the numerical scheme has the following form:*

$$\begin{pmatrix} {}_0^{r-s}D_0^{\alpha(t)} f(t) \\ {}_0^{r-s}D_h^{\alpha(t)} f(t) \\ \vdots \\ {}_0^{r-s}D_{T-h}^{\alpha(t)} f(t) \\ {}_0^{r-s}D_T^{\alpha(t)} f(t) \\ \vdots \\ {}_0^{r-s}D_{kh}^{\alpha(t)} f(t) \end{pmatrix} = \lim_{h \rightarrow 0} W(\alpha_2, k)M(\hat{\alpha}_1, k, \tau - 1) \begin{pmatrix} f(0) \\ f(h) \\ \vdots \\ f(T - h) \\ f(T) \\ \vdots \\ f(kh) \end{pmatrix},$$

where

$$M(\hat{\alpha}_1, k, \tau - 1) = \begin{pmatrix} W(\hat{\alpha}_1, \tau - 1) & 0_{\tau, k-\tau+1} \\ 0_{k-\tau+1, \tau} & I_{k-\tau+1, k-\tau+1} \end{pmatrix},$$

and

$$\alpha(t) = \begin{cases} \alpha_2 + \hat{\alpha}_1 & \text{for } t < T, \\ \alpha_2 & \text{for } t \geq T. \end{cases} \tag{32}$$

The order  $\hat{\alpha}_1$ , appearing above, is given by relation (31).

**Theorem 3** *In the case of simple switching (between two orders), matrix description (20) corresponding to the 4th type of fractional variable-order derivative is equivalent to the matrix form of simple reductive-switching order derivative scheme given in Lemma 5.*

*Proof* Let us consider the switching order given by (32). In the case of simple reductive-switching scheme based on Lemma 5, we have the following switching description



$$\begin{aligned} r\text{-}P &= \left( \begin{array}{c|c} W(\alpha_2, \tau - 1) & 0_{\tau, k+1-\tau} \\ \hline A(\alpha_2) & W(\alpha_2, k - \tau) \end{array} \right) \left( \begin{array}{c|c} W(\hat{\alpha}_1, \tau - 1) & 0_{\tau, k+1-\tau} \\ \hline 0_{k+1-\tau, \tau} & I_{k+1-\tau, k+1-\tau} \end{array} \right) \\ &= \left( \begin{array}{c|c} W(\alpha_1, \tau - 1) & 0_{\tau, k+1-\tau} \\ \hline A(\alpha_2)W(\hat{\alpha}_1, \tau - 1) & W(\alpha_2, k - \tau) \end{array} \right), \end{aligned}$$

where  $A(\alpha_2) \in \mathbb{R}^{(k+1-\tau) \times \tau}$ , and where we have used the already known property, resulting  $W(\alpha_2, \tau - 1)W(\hat{\alpha}_1, \tau - 1) = W(\alpha_2 + \hat{\alpha}_1, \tau - 1) = W(\alpha_1, \tau - 1)$  (see, e.g., [16]).

From the other hand, for the 4th type of derivative and the same switching between orders given by (32), we have the following switching matrix form based on (3):

$$\begin{aligned} \mathcal{D}P &= Q_\tau^k Q_0^{\tau-1} = \left( \begin{array}{c|c} I_{\tau, \tau} & 0_{\tau, k+1-\tau} \\ \hline B(\alpha_2) & C(\alpha_2) \end{array} \right) \left( \begin{array}{c|c} D(\alpha_1) & 0_{\tau, k+1-\tau} \\ \hline 0_{k+1-\tau, \tau} & I_{k+1-\tau, k+1-\tau} \end{array} \right) \\ &= \left( \begin{array}{c|c} D(\alpha_1) & 0_{\tau, k+1-\tau} \\ \hline B(\alpha_2)D(\alpha_1) & C(\alpha_2) \end{array} \right), \end{aligned}$$

where  $B(\alpha_2) \in \mathbb{R}^{(k+1-\tau) \times \tau}$ ,  $C(\alpha_2) \in \mathbb{R}^{(k+1-\tau) \times (k+1-\tau)}$ , and  $D(\alpha_1) \in \mathbb{R}^{\tau \times \tau}$  are the suitable block matrices. Assuming for a moment that if we would not change the order, i.e.,  $\alpha_1 = \alpha_2 = \alpha$ , we would obtain  $\mathcal{D}P = W(\alpha, k)$  according to Remark 1. From this, we conclude that  $D(\alpha) = W(\alpha, \tau - 1)$  and  $C(\alpha) = W(\alpha, k - \tau)$ , and then it gives rise to

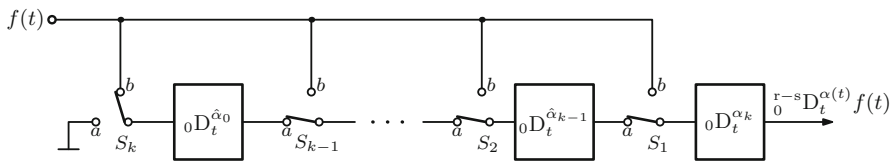
$$\mathcal{D}P = \left( \begin{array}{c|c} W(\alpha_1, \tau - 1) & 0_{\tau, k+1-\tau} \\ \hline B(\alpha_2)W(\alpha_1, \tau - 1) & W(\alpha_2, k - \tau) \end{array} \right).$$

Now, we have to show that  $B(\alpha_2)W(\alpha_1, \tau - 1) = A(\alpha_2)W(\hat{\alpha}_1, \tau - 1)$ . Assume again for a moment that we do not switch the order, i.e., we have  $\alpha_1 = \alpha_2 = \alpha$ , both in the case of 4th definition and simple-reductive case. Thus, using again Remark 1, we get

$$B(\alpha)W(\alpha, \tau - 1) = A(\alpha),$$

because  $\hat{\alpha}_1 = 0$ , and then  $W(\hat{\alpha}_1, \tau - 1) = I_{\tau, \tau}$ , from which we conclude that

$$A(\alpha_2) = B(\alpha_2)W(\alpha_2, \tau - 1), \tag{33}$$



**Fig. 10** Structure of multiple reductive-switching order derivative  ${}^{r-s}D_t^{\alpha(t)} f(t)$  (configuration before switch between orders  $\alpha_0$  and  $\alpha_1$ )

and then, using (33)

$$\begin{aligned} A(\alpha_2)W(\hat{\alpha}_1, \tau - 1) &= B(\alpha_2)W(\alpha_2, \tau - 1)W(\hat{\alpha}_1, \tau - 1) \\ &= B(\alpha_2)W(\alpha_2 + \hat{\alpha}_1, \tau - 1) \\ &= B(\alpha_2)W(\alpha_1, \tau - 1). \end{aligned}$$

Finally, we get  ${}^{\mathcal{D}}P = {}^{r-s}P$ , which ends the proof. □

### 8.2 Multiple Reductive-Switching Order Case

The reductive-switching order case occurs when the initial chain of derivatives is reduced according to changing the variable-order (Fig. 10).

The switching rule in the multiple-switching case is an analogous extension of the simple-switching case described in Sect. 8.1.

**Lemma 6** *For a multiple reductive-switching order case, when the switch between orders  $\alpha_0, \dots, \alpha_k$  occurs every  $ih$  time instant, the numerical scheme has the following form:*

$$\begin{pmatrix} {}^{r-s}D_0^{\alpha(t)} f(t) \\ {}^{r-s}D_h^{\alpha(t)} f(t) \\ \vdots \\ {}^{r-s}D_{kh}^{\alpha(t)} f(t) \end{pmatrix} = \lim_{h \rightarrow 0} W(\alpha_k, k) \prod_{i=0}^{k-1} M(\hat{\alpha}_{k-1-i}, k, k-1-i) \begin{pmatrix} f(0) \\ f(h) \\ \vdots \\ f(kh) \end{pmatrix},$$

where

$$M(\hat{\alpha}_{k-1-i}, k, k-1-i) = \begin{pmatrix} W(\hat{\alpha}_{k-1-i}, k-1-i) & 0_{k-i, i+1} \\ 0_{i+1, k-i} & I_{i+1, i+1} \end{pmatrix},$$

and

$$\alpha(t) = \begin{cases} \alpha_{i+1} + \hat{\alpha}_i & \text{for } 0 \leq t < (i+1)h, \\ \alpha_{i+1} & \text{for } t \geq (i+1)h, \end{cases} \quad i = 0, \dots, k-1.$$

The proof of Lemma 6 is a straightforward extension of the proof of Lemma 5 given in [30].

**Theorem 4** *Matrix description (20) corresponding to the 4th type of fractional-order derivative definition is equivalent to the matrix form of multiple reductive-switching order scheme given by Lemma 6, i.e.,*

$${}_0^{\mathcal{D}}D_t^{\alpha(t)} f(t) \equiv {}_0^{r-s}D_t^{\alpha(t)} f(t).$$

*Proof* In order to proof this theorem, we will use the introduced in Sect. 7 fact about the duality between 1st and 4th type of fractional variable-order derivatives; it means that we have

$$(\Omega_0^k(\alpha))^{-1} = {}^A W(-\alpha, k),$$

where  ${}^A W(-\alpha, k)$  is equal to the matrix product given by (7) expressed for  $-\alpha$ . Thus, instead of calculating

$$(\Omega_0^k(\alpha))^{-1} W(\alpha_k, k) \prod_{i=0}^{k-1} M(\hat{\alpha}_{k-1-i}, k, k-1-i),$$

we perform the following composition

$$\left( \prod_{i=0}^{k-1} M(-\hat{\alpha}_i, k, i) \right) W(-\alpha_k, k) W(\alpha_k, k) \prod_{i=0}^{k-1} M(\hat{\alpha}_{k-1-i}, k, k-1-i) = I_{k+1, k+1},$$

which yields the identity, and thereby ends the proof. □

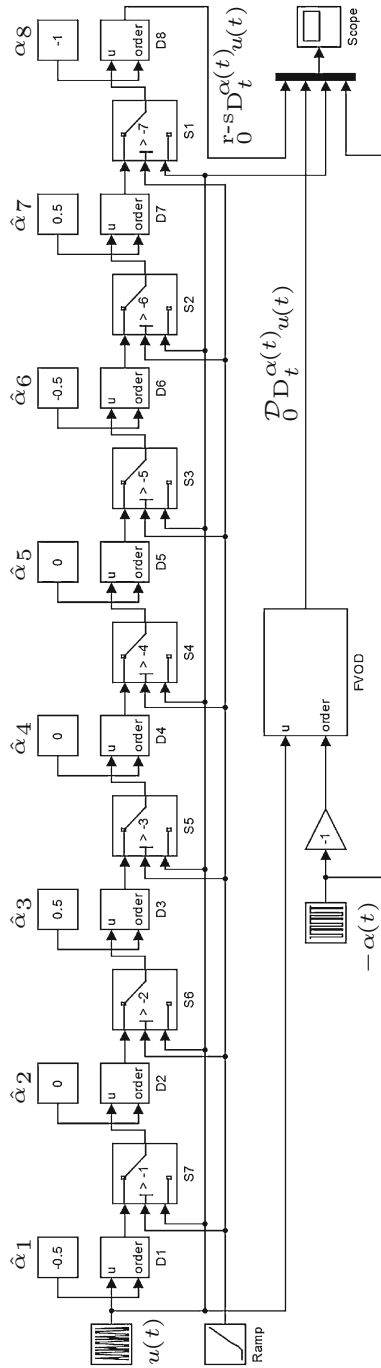
### 9 Numerical Verification of Equivalence Between Switching-Order scheme and 4th Type Derivative

Numerical verification of reductive-switching scheme is done in Simulink by comparing it to the numerical implementation of the recursive fractional variable-order derivative. It is depicted in Fig. 11, where:  $Di, i = 1, \dots, 8$ , are fractional constant-order derivative blocks,  $Si, i = 1, \dots, 7$ , are switching blocks, and FVOD is the numerical implementation of the recursive fractional variable-order derivative (for more details see [23]).

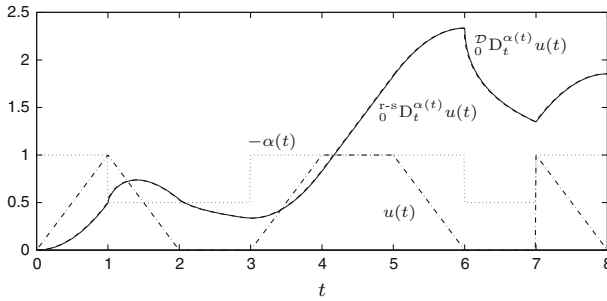
The effects of simulation according to Fig. 11 are depicted in Fig. 12, where the equivalence between recursive definition and reductive-switching scheme is also verified.

### 10 Analog Realization of Switching-Order Scheme

In this section, an analog circuit that corresponds to the proposed numerical definition of 4th type is presented.

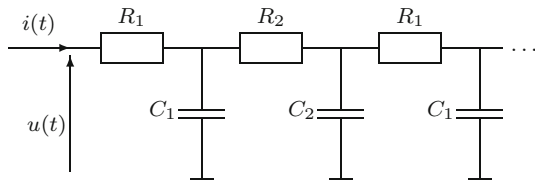


**Fig. 11** Simulink realization of reductive-switching derivative  ${}_{F^S}D_t^{\alpha(t)} u(t)$  and 4th definition derivative  $D_0^4 u(t)$

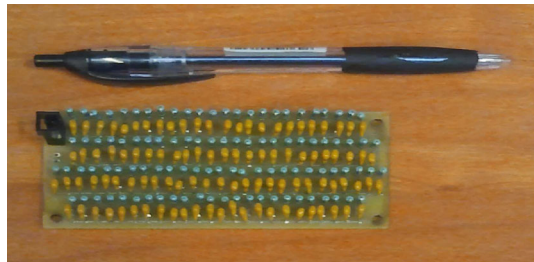


**Fig. 12** Comparison of derivative definitions  ${}^{r-s}D_t^{\alpha(t)} u(t)$  and  ${}^{\mathcal{D}}D_t^{\alpha(t)} u(t)$  of variable-order  $\alpha(t)$  and function  $u(t)$

**Fig. 13** An analog model of half-order integrator



**Fig. 14** A circuit board of half-order integrator



### 10.1 Analog Realization of the Half-Order Integral

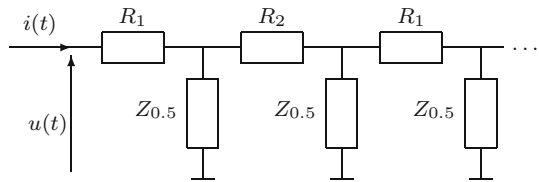
In this paper, the following method of half-order integrator implementation, introduced in [24], and meticulously investigated in [14,29], will be used. The scheme of this method is presented in Fig. 13.

Based on the algorithm described in details in [24], the experimental circuit boards of half-order impedances were constructed. The circuit board that has been used in experimental setup is presented in Fig. 14. The circuit consists of 200 discrete elements with the following values:  $R_1 = 2.4 \text{ k}\Omega$ ,  $R_2 = 8.2 \text{ k}\Omega$ ,  $C_1 = 330 \text{ nF}$ , and  $C_2 = 220 \text{ nF}$ .

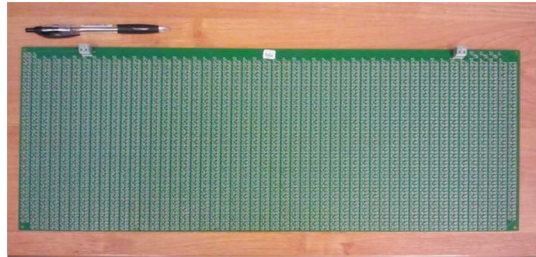
### 10.2 Analog Realization of the 0.25 Order Impedance

Method mentioned in Sect. 10.1 can be extended to build a fractional order integrator of order 0.25. This can be done by replacing the capacitors in the scheme in Fig. 13 by half-order integrators, which can be 0.5 order domino ladders. This gives an impedance of order  $\alpha = 0.25$ , which corresponds to a quarter-order integrator.

**Fig. 15** An analog model  $\alpha = 0.25$  order integrator



**Fig. 16** A circuit board of the 0.25 order integrator

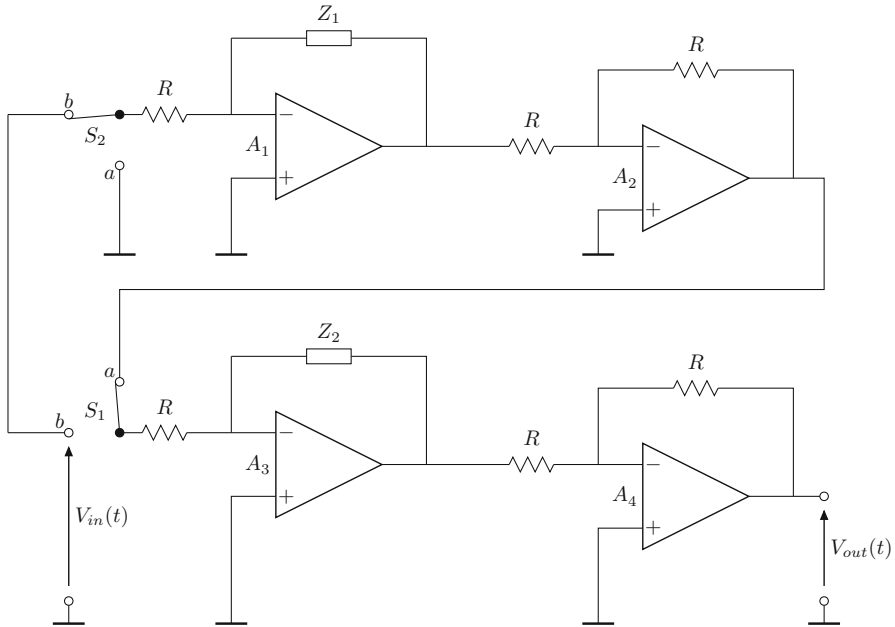


In Fig. 15, the scheme of the approximation of a quarter-order integrator is shown;  $Z_{0.5}$  is the impedance of half-order domino ladder. As a quarter-order impedance, the circuit board presented in Fig. 16 has been used. The board contains about 5,000 discrete elements and was designed according to the scheme shown in Fig. 15. The main ladder includes 50 branches with the following resistors' values:  $R_1 = 2.4 \text{ k}\Omega$ ,  $R_2 = 8.2 \text{ k}\Omega$ . The half-order integrators have been used in the quarter ladders denoted as  $Z_{0.5}$  on the scheme.

### 10.3 Experimental Setup

Analog model of switching system, used in experimental setup, corresponds to the switching scheme given in Fig. 9. It contains four TL071 operational amplifiers: two ( $A_1$  and  $A_3$ ) in fractional integrator configuration, and two ( $A_2$  and  $A_4$ ) in inverting amplifier configuration. All of operational amplifiers were supplied with external symmetrical voltage source  $\pm 12 \text{ V}$ . The fractional integrators were realized similarly to configuration of analog realization of integer order integrator, but in place of capacitor the fractional impedances  $Z_1$ ,  $Z_2$  were used. The fractional order impedances were the domino ladder approximations presented in Sects. 10.1 and 10.2. In such a configuration, obtained output signal is inverted, that is why another operational amplifier in configuration of inverted amplifier is used. The operational amplifier TL071 was specially used, because it has ability to connect special circuit for voltage offset reduction; the scheme of this circuit is described in amplifier data-sheet [7, Fig. 3]. Reduction of this offset voltage is very important, because of integration character of the circuits, and integrated offset could have significant influence in simulation error. We have equipped all used operational amplifiers in Input Offset-Voltage Null Circuit and we tuned it before obtaining experimental results.

As a realization of switches  $S_1$  and  $S_2$ , integrated analog switches DG303 were used. Fractional order impedances with order equal to  $-0.5$  or  $-0.25$ , used in exper-



**Fig. 17** Analog realization of the 4th type of fractional variable-order integral

iments, are shown in Figs. 14 and 16, respectively. The experimental circuit (for data acquisition and DG303 switches control) was connected to the dSPACE DS1104 PPC card with a PC. Resistors  $R$  allow to adjust a gain of integrators, and impedances  $Z_1$  and  $Z_2$  are used to obtain desired switching-order configuration (according to the reductive-switching scheme presented in Fig. 9). At the beginning, both integrators are connected in the series (switch  $S_1$  is in position  $a$ , and switch  $S_2$  is in position  $b$ ), and after order switch in time  $T$  the integrator at front of the chain (based on impedance  $Z_1$ ) is disconnected (switch  $S_1$  is in position  $b$ , and switch  $S_2$  is in position  $a$ ).

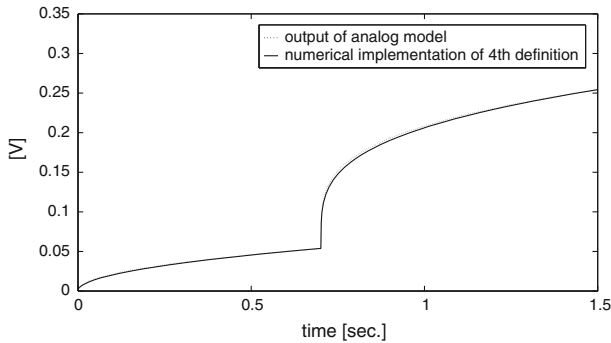
#### 10.4 Experimental Results

**Example 6** Integrator with switched orders from  $\alpha = -0.5$  to  $\alpha = -0.25$ .

In this case, according to the scheme in Fig. 17, the structure has the following parameters:  $Z_1$  and  $Z_2$  are the quarter-order integrators,  $R = 100 \text{ k}\Omega$ . The identification results were obtained by numerical minimization of time responses square error for constant orders, time interval  $t \in [0, 1.5]$ , with sampling time  $T_s = 0.001 \text{ s}$ , and input signal  $u(t) = 1(t)$  being the Heaviside step function. After identification process, the following models for orders  $-0.5$  and  $-0.25$ , respectively, in time domain, were obtained:

$$y(t) = {}_0D_t^{-0.5} a_1 u(t) = 0.0567 {}_0D_t^{-0.5} u(t),$$

$$y(t) = {}_0D_t^{-0.25} a_2 u(t) = 0.2359 {}_0D_t^{-0.25} u(t).$$



**Fig. 18** Results of analog and numerical implementation of the 4th type derivative for switching order from  $\alpha = -0.5$  to  $\alpha = -0.25$  (Example 6)

which gives rise to the following variable-order integrator:

$$y(t) = {}_0^{\mathcal{D}}D_t^{\alpha(t)}(a(t)u(t)),$$

or using the duality property:

$${}_0^{\mathcal{A}}D_t^{-\alpha(t)}y(t) = a(t)u(t),$$

where (for the switching time  $T = 0.7$  s.)

$$a(t) = \begin{cases} 0.0567 & \text{for } t \leq 0.7, \\ 0.2359 & \text{for } t > 0.7, \end{cases}$$

and

$$\alpha(t) = \begin{cases} -0.5 & \text{for } t \leq 0.7, \\ -0.25 & \text{for } t > 0.7. \end{cases}$$

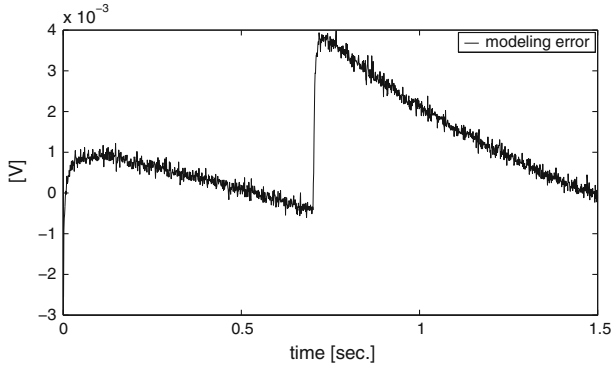
The experimental results compared to numerical implementation of the 4th type of variable-order derivative definition are presented in Figs. 18 and 19.

*Example 7* Integrator with switched orders from  $\alpha = -1$  to  $\alpha = -0.5$ .

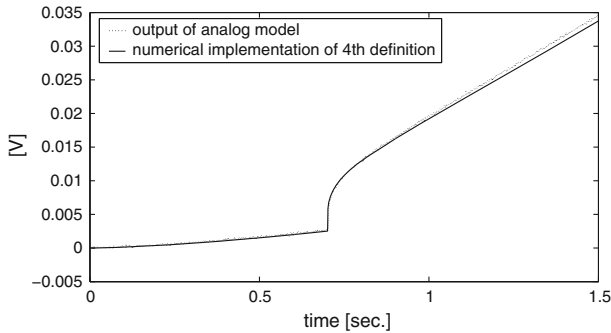
In this configuration, according to the scheme in Fig. 17:  $Z_1$  and  $Z_2$  are the half-order integrators,  $R = 100$  k $\Omega$ . The identification results were obtained by numerical minimization of time responses square error with sampling time  $T_s = 0.001$  s, and input signal  $u(t) = 0.01 \cdot 1(t)$ . After identification process, the following models for orders  $-1$  and  $-0.5$ , respectively, in time domain, were obtained:

$$\begin{aligned} y(t) &= {}_0D_t^{-1}a_1u(t) = 2.23{}_0D_t^{-1}u(t), \\ y(t) &= {}_0D_t^{-0.5}a_2u(t) = 1.4940{}_0D_t^{-0.5}u(t). \end{aligned}$$





**Fig. 19** Difference between analog and numerical implementation of the 4th type derivative for switching order from  $\alpha = -0.5$  to  $\alpha = -0.25$  (Example 6)



**Fig. 20** Results of analog and numerical implementation of the 4th type derivative for switching order from  $\alpha = -0.5$  to  $\alpha = -0.25$  (Example 8)

The switching time was equal to 0.7 s. The experimental results are presented in Fig. 3.

*Example 8* Integrator with switched orders from  $\alpha = -0.5$  to  $\alpha = -0.25$  of ramp function input signal.

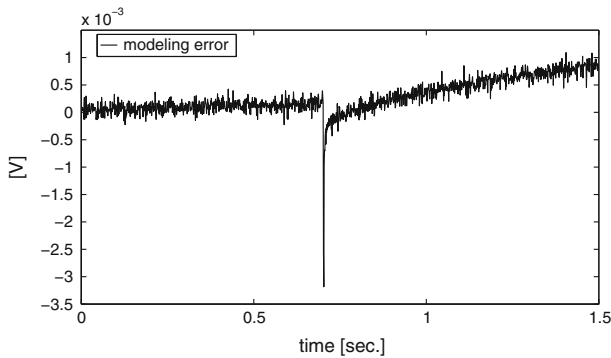
In this example, configuration of the experimental setup is similar to the one already used in Example 6.

The identification results were obtained by numerical minimization of time responses square error with sampling time  $T_s = 0.001$  s, and input signal  $u(t) = 0.1 \cdot t1(t)$ . After identification process, the following models for orders  $-0.5$  and  $-0.25$ , respectively, in time domain, were obtained:

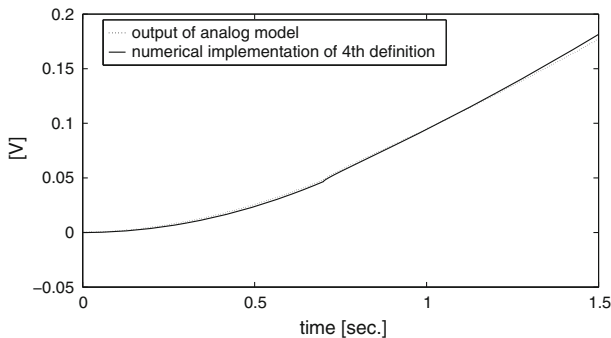
$$y(t) = {}_0D_t^{-0.5} a_1 u(t) = 0.0570 {}_0D_t^{-0.5} u(t),$$

$$y(t) = {}_0D_t^{-0.25} a_2 u(t) = 0.23580 {}_0D_t^{-0.25} u(t).$$

The switching time was equal to 0.7 s. The experimental results are presented in Figs. 20 and 21.



**Fig. 21** Difference between analog and numerical implementation of the 4th type derivative for switching order from  $\alpha = -0.5$  to  $\alpha = -0.25$  (Example 8)



**Fig. 22** Results of analog and numerical implementation of the 4th type derivative for switching order from  $\alpha = -1$  to  $\alpha = -0.5$  (Example 9)

*Example 9* Integrator with switched orders from  $\alpha = -1$  to  $\alpha = -0.5$  of ramp function input signal.

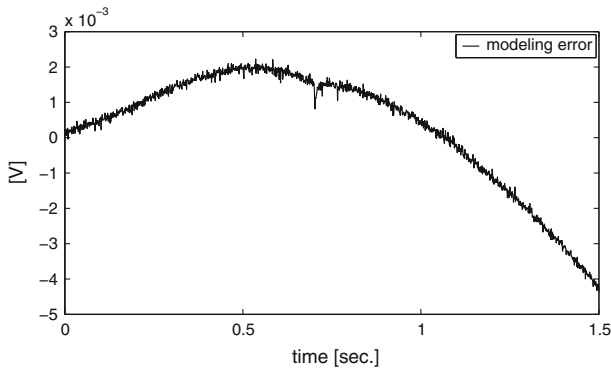
In this example, configuration of the experimental setup is similar to the one already used in Example 7.

The identification results were obtained by numerical minimization of time responses square error with sampling time  $T_s = 0.001$  s, and input signal  $u(t) = 0.1 \cdot t1(t)$ . After identification process, the following models for orders  $-1$  and  $-0.5$ , respectively, in time domain, were obtained:

$$y(t) = {}_0D_t^{-1}a_1u(t) = 1.78240{}_0D_t^{-1}u(t),$$

$$y(t) = {}_0D_t^{-0.5}a_2u(t) = 1.35140{}_0D_t^{-0.5}u(t).$$

The switching time was equal to 0.7 s. The experimental results are presented in Figs. 22 and 23.



**Fig. 23** Difference between analog and numerical implementation of the 4th type derivative for switching order from  $\alpha = -1$  to  $\alpha = -0.5$  (Example 9)

## 11 Conclusions

The paper presented a recursive definition of variable-order differ-integral stated in the form of difference equation, and also in the derived equivalent matrix form. This new definition is also expressed in the form of fractional variable-order derivative. The main result of the paper is a derivation of the identity between the presented recursive definition and the reductive-switching scheme of variable-order derivative. Moreover, in the paper, the equivalence between the 1st type of variable-order derivative definition and the output-switching scheme is also derived and presented. The obtained results allow us to better understand the behavior and peculiarity of this type of definitions of variable-order derivative. Based on this knowledge, it can give rise to more appropriate choice of definitions type, depending on particular application. The paper presents also an analog circuit that corresponds to the proposed numerical definition. Our obtained experimental results show high accuracy of the proposed method of analog modeling. The obtained results can be used, in the future, to improve existing algorithms in control and signal processing areas.

**Acknowledgments** This work was supported by the Polish National Science Center with the decision number DEC-2011/03/D/ST7/00260.

**Open Access** This article is distributed under the terms of the Creative Commons Attribution License which permits any use, distribution, and reproduction in any medium, provided the original author(s) and the source are credited.

## References

1. D. Chen, Z. Sun, X. Ma, L. Chen, Circuit implementation and model of a new multi-scroll chaotic system. *Int. J. Circuit Theory Appl.* 407–424 (2012). doi:[10.1002/cta.1860](https://doi.org/10.1002/cta.1860)
2. D. Chen, C. Liu, C. Wu, Y. Liu, X. Ma, Y. You, A new fractional-order chaotic system and its synchronization with circuit simulation. *Circuits, Syst. Signal Process.* **31**(5), 1599–1613 (2012). doi:[10.1007/s00034-012-9408-z](https://doi.org/10.1007/s00034-012-9408-z)
3. D. Chen, C. Wu, H. Iu, X. Ma, Circuit simulation for synchronization of a fractional-order and integer-order chaotic system. *Nonlinear Dyn.* **73**(3), 1671–1686 (2013)

4. A. Dzielinski, G. Sarwas, D. Sierociuk, Time domain validation of ultracapacitor fractional order model. In *49th IEEE Conference on Decision and Control (CDC)*, 2010, pp. 3730–3735. doi:[10.1109/CDC.2010.5717093](https://doi.org/10.1109/CDC.2010.5717093).
5. A. Dzielinski, G. Sarwas, D. Sierociuk, Comparison and validation of integer and fractional order ultracapacitor models. *Adv. Differ. Equ.* **2011**, 11 (2011). doi:[10.1186/1687-1847-2011-11](https://doi.org/10.1186/1687-1847-2011-11)
6. A. Dzielinski, D. Sierociuk, Fractional order model of beam heating process and its experimental verification, in *New Trends in Nanotechnology and Fractional Calculus Applications*, ed. by D. Baleanu, Z.B. Guvenc, J.A.T. Machado (Springer, Netherlands, 2010), pp. 287–294
7. Texas Instruments, *TL07x Low-Noise JFET-Input Operational Amplifiers* (2014). <http://www.ti.com/lit/ds/symlink/tl071.pdf>. Accessed 30 Sept 2014
8. C. Lorenzo, T. Hartley, Variable order and distributed order fractional operators. *Nonlinear Dyn.* **29**(1–4), 57–98 (2002). doi:[10.1023/A:1016586905654](https://doi.org/10.1023/A:1016586905654)
9. K. Miller, B. Ross, *An Introduction to the Fractional Calculus and Fractional Differential Equations* (Wiley, New York, 1993)
10. C.A. Monje, Y. Chen, B.M. Vinagre, D. Xue, V. Feliu, *Fractional-order Systems and Controls*. Springer, Berlin (2010).
11. K.B. Oldham, J. Spanier, *The Fractional Calculus*. Academic Press, Waltham, MA (1974).
12. P. Ostalczyk, T. Rybicki, Variable-fractional-order dead-beat control of an electromagnetic servo. *J. Vib. Control* **14**(9–10), 1457–1471 (2008)
13. P. Ostalczyk, Stability analysis of a discrete-time system with a variable-, fractional-order controller. *Bull. Polish Acad. Sci.* **58**(4), 613–619 (2010)
14. I. Petras, D. Sierociuk, I. Podlubny, Identification of parameters of a half-order system. *IEEE Trans. Signal Process.* **60**(10), 5561–5566 (2012). doi:[10.1109/TSP.2012.2205920](https://doi.org/10.1109/TSP.2012.2205920)
15. I. Podlubny, *Fractional Differential Equations*. Academic Press, Waltham, MA (1999).
16. I. Podlubny, Matrix approach to discrete fractional calculus. *Frac. Calc. Appl. Anal.* **3**, 359–386 (2000)
17. I. Podlubny, A. Chechkin, T. Skovranek, Y. Chen, B.M. Vinagre Jara, Matrix approach to discrete fractional calculus II: partial fractional differential equations. *J. Comput. Phys.* **228**(8), 3137–3153 (2009)
18. L. Ramirez, C. Coimbra, On the variable order dynamics of the nonlinear wake caused by a sedimenting particle. *Physica D-Nonlinear Phenom.* **240**(13), 1111–1118 (2011)
19. S. Samko, A. Kilbas, O. Marichev, *Theory and Applications, Fractional integrals and derivative* (Gordon and Breach, London, 1987)
20. H. Sheng, H. Sun, C. Coopmans, Y. Chen, G.W. Bohannan, Physical experimental study of variable-order fractional integrator and differentiator. In *Proceedings of the 4th IFAC Workshop Fractional Differentiation and its Applications FDA'10* (2010).
21. H. Sheng, H. Sun, Y. Chen, T. Qiu, Synthesis of multifractional gaussian noises based on variable-order fractional operators. *Signal Process.* **91**(7), 1645–1650 (2011)
22. H. Sheng, Y. Chen, T. Qiu, *Signal Processing Fractional Processes and Fractional-Order Signal Processing* (Springer, London, 2012)
23. D. Sierociuk, *Fractional Variable Order Derivative Simulink Toolkit* (2012). <http://www.mathworks.com/matlabcentral/fileexchange/38801-fractional-variable-order-derivative-simulink-toolkit>. Accessed 30 Sept 2014
24. D. Sierociuk, A. Dzielinski, New method of fractional order integrator analog modeling for orders 0.5 and 0.25. In *Proceedings of the 16th International Conference on Methods and Models in Automation and Robotics (MMAR)*, 2011, pp. 137–141. Miedzyzdroje, Poland (2011). doi:[10.1109/MMAR.2011.6031332](https://doi.org/10.1109/MMAR.2011.6031332).
25. D. Sierociuk, A. Dzielinski, G. Sarwas, I. Petras, I. Podlubny, T. Skovranek, Modelling heat transfer in heterogeneous media using fractional calculus. *Philos. Trans. Royal Soc. A* **371**(1990), 20120146 (2013).
26. D. Sierociuk, W. Malesza, M. Macias, Equivalent switching strategy and analog validation of the fractional variable order derivative definition. In *Proceedings of European Control Conference ECC'2013*, Zurich pp. 3464–3469 (2013).
27. D. Sierociuk, W. Malesza, M. Macias, On a new definition of fractional variable-order derivative. In *Proceedings of the 14th International Carpathian Control Conference (ICCC)*, (Rytko, Poland 2013), pp. 340–345. doi:[10.1109/CarpathianCC.2013.6560566](https://doi.org/10.1109/CarpathianCC.2013.6560566).

28. D. Sierociuk, W. Malesza, M. Macias, Switching scheme, equivalence, and analog validation of the alternative fractional variable-order derivative definition. In *Proceedings of the 52nd IEEE Conference on Decision and Control*, Florence, Italy, December 10–13, 2013.
29. D. Sierociuk, I. Podlubny, I. Petras, Experimental evidence of variable-order behavior of ladders and nested ladders. *IEEE Trans. Control Syst. Technol.* **21**(2), 459–466 (2013). doi:[10.1109/TCST.2012.2185932](https://doi.org/10.1109/TCST.2012.2185932)
30. D. Sierociuk, M. Macias, W. Malesza, Analog modeling of fractional switched order derivative using different switching schemes. *IEEE J. Emerg. Sel. Topics Circuits Syst.* **3**(3), 394–403 (2013)
31. C.C. Tseng, Design and application of variable fractional order differentiator. In *Proceedings of the 2004 IEEE Asia-Pacific Conference on Circuits and Systems*, vol. 1, pp. 405–408 (2004).
32. D. Valerio, J.S. da Costa, Variable-order fractional derivatives and their numerical approximations II-complex orders. In *Proceedings of the Symposium on Fractional Signals and Systems*, Caparica (2009).
33. D. Valerio, J.S. da Costa, Variable-order fractional derivatives and their numerical approximations. *Signal Process.* **91**(3, SI), 470–483 (2011). doi:[10.1016/j.sigpro.2010.04.006](https://doi.org/10.1016/j.sigpro.2010.04.006).
34. D. Valerio, B. Vinagre, J. Domingues, J.S. da Costa, Variable-order fractional derivatives and their numerical approximations I-real orders. In *Proceedings of the Symposium on Fractional Signals and Systems*, Caparica, 2009 (2009).