

Invariant Surfaces of the Heisenberg Groups (*).

CHRISTIAM B. FIGUEROA - FRANCESCO MERCURI - RENATO H. L. PEDROSA

Summary. – *We fix a left-invariant metric g in the Heisenberg group, \mathcal{H}_3 , and give a complete classification of the constant mean curvature surfaces (including minimal) which are invariant with respect to 1-dimensional closed subgroups of the connected component of the isometry group of (\mathcal{H}_3, g) . In addition to finding new examples, we organize in a common framework results that have appeared in various forms in the literature, by the systematic use of Riemannian transformation groups. Using the existence of a family of spherical surfaces for all values of nonzero mean curvature, we show that there are no complete graphs of constant mean curvature. We extend some of these results to the higher dimensional Heisenberg groups \mathcal{H}_{2n+1} .*

Introduction.

The 3-dimensional Heisenberg group \mathcal{H}_3 is the two-step nilpotent Lie group standardly represented in $GL_3(\mathbb{R})$ by

$$\begin{bmatrix} 1 & r & t \\ 0 & 1 & s \\ 0 & 0 & 1 \end{bmatrix},$$

with $r, s, t \in \mathbb{R}$.

Endowed with a left-invariant metric g , (\mathcal{H}_3, g) has a rich geometric structure, reflected by the fact that its group of isometries $\mathfrak{Iso}(\mathcal{H}_3, g)$ is of dimension 4 (cf. Theorem 1 below). It is known ([19], Theorem 3.2) that the isometry group of an n -dimensional Riemannian manifold cannot have dimension between $n(n-1)/2+1$ and $n(n+1)/2$, for $n \neq 4$, and that the upper bound characterizes the spaces of constant curvature ([19], Theorem 3.1). This means that (\mathcal{H}_3, g) has isometry group of the

(*) Entrata in Redazione il 2 aprile 1998.

Indirizzo degli AA.: Departamento de Matemática, C.P. 6065, Imecc, Unicamp, 13081-970, Campinas, SP, Brazil; E-mail address: figueroa@ime-unicamp.br; E-mail address: mercuri@ime.unicamp.br; E-mail address: pedrosa@ime.unicamp.br

The first author was supported by Fapesp (Brazil), the second was partially supported by Fapesp and CNPq (Brazil), and the third was partially supported by Fapesp.

largest possible dimension for a space of non-constant curvature. It also appears in many other contexts, such as complex hyperbolic geometry ([13]), Carnot-Caratheodory metrics ([15]), thus making it a 3-dimensional manifold worth studying.

Now, in order to describe a left-invariant metric on \mathcal{H}_3 , we note that the Lie algebra \mathfrak{h}_3 of \mathcal{H}_3 is given by the matrices

$$A = \begin{bmatrix} 0 & a & c \\ 0 & 0 & b \\ 0 & 0 & 0 \end{bmatrix}$$

with a, b, c real. Using the exponential map $\exp: \mathfrak{h}_3 \rightarrow \mathcal{H}_3$,

$$\exp(A) = I + A + \frac{A^2}{2} = \begin{bmatrix} 1 & a & c + \frac{1}{2}ab \\ 0 & 1 & b \\ 0 & 0 & 1 \end{bmatrix},$$

as a global parametrization, with the identification of the Lie algebra \mathfrak{h}_3 with \mathbb{R}^3 given by

$$(a, b, s) \leftrightarrow \begin{bmatrix} 0 & a & c \\ 0 & 0 & b \\ 0 & 0 & 0 \end{bmatrix},$$

the group structure of \mathcal{H}_3 is given by

$$X_1 \star X_2 = (x_1, y_1, z_1) \star (x_2, y_2, z_2) = X_1 + X_2 + L(X_1) \cdot X_2,$$

where

$$L(X_1) = \begin{bmatrix} 0 & 0 & 0 \\ 0 & 0 & 0 \\ -\frac{y_1}{2} & \frac{x_1}{2} & 0 \end{bmatrix}.$$

From now on, we will always use these exponential coordinates.

The Lie algebra bracket, in terms of the canonical basis $\{e_1, e_2, e_3\}$ of \mathbb{R}^3 , is given by:

$$\begin{cases} [e_1, e_2] = e_3, \\ [e_i, e_3] = 0, & i = 1, 2, 3. \end{cases}$$

Using $\{e_1, e_2, e_3\}$ as the orthonormal frame at the identity, we have that an orthonor-

mal basis of left-invariant vector fields is given in exponential coordinates by

$$E_1 = \frac{\partial}{\partial x} - \frac{y}{2} \frac{\partial}{\partial z}, \quad E_2 = \frac{\partial}{\partial y} + \frac{x}{2} \frac{\partial}{\partial z}, \quad E_3 = \frac{\partial}{\partial z},$$

and the left-invariant metric g in exponential coordinates is given by

$$(1) \quad ds^2 = dx^2 + dy^2 + \left(\frac{1}{2} y dx - \frac{1}{2} x dy + dz \right)^2.$$

Fore more information on the properties of these metrics, see [14].

Next, we describe briefly the contents and organization of the paper.

In Section 1 we obtain the basic information about the isometry group $\mathfrak{Iso}(\mathcal{H}_3, g)$ of (\mathcal{H}_3, g) . This result is a detailed version of a result of Kaplan [18], and there is a higher-dimensional version in Section 5 (Theorem 7). Using it, we describe the 1-dimensional closed subgroups of $\mathfrak{Iso}(\mathcal{H}_3, g)$, the connected component of $\mathfrak{Iso}(\mathcal{H}_3, g)$ (Theorem 2). Section 2 contains a review of the Riemannian transformation groups results needed to formulate an orbital version of the mean curvature equation for a G -invariant submanifold (Reduction Theorem), for G a closed subgroup of $\mathfrak{Iso}_0(\mathcal{H}_3, g)$. This result, in the form used here (the group acting may be noncompact), is from the unpublished paper [1], and a complete proof is included in Appendix A. In Section 3, we study the surfaces invariant under screw motions, i.e., invariant under the subgroup generated by a rotation about the z -axis together with a z -translation (Theorem 3). Using a standard maximum principle technique, we show that there are no complete «graphs» of nonzero constant mean curvature in \mathcal{H}_3 (theorem 4). Section 4 contains the study of surfaces invariant under left-translations (Theorems 5, 6). These results extend and put under a common framework various results on the existence of minimal and constant mean curvature surfaces in the Heisenberg group that have appeared recently in the literature ([3, 4, 27, 7]). Section 5 has as subject extensions of the previous results to the higher dimensional Heisenberg groups \mathcal{H}_{2n+1} . We close with some commentaries and problems.

1. – The isometry group of \mathcal{H}_3 and its closed 1-dimensional subgroups.

THEOREM 1 ([18]). – *Let g be a left-invariant metric on \mathcal{H}_3 . Then $\mathfrak{Iso}_0(\mathcal{H}_3, g)$ is isomorphic to the semidirect product of \mathcal{H}_3 and $SO(2)$, with \mathcal{H}_3 acting by left translations. In the exponential coordinates given above, $SO(2)$ acts by rotations about the z -axis.*

PROOF. – We note firstly that any left-invariant metric will be given by choosing by some orthonormal basis of the Lie algebra \mathfrak{h}_3 . Then, a (linear) change of variables and normalization will put the new metric in the form given by equation (1). Next, it is easy to check that the rotations ρ_θ by an angle θ about the z -axis are isometries (however, the reflections through vertical planes are not included). Now, noting that right and left translations commute, we get that the Killing vector fields generating the left translations are given by the right-invariant vector fields. Including the rotations ρ_θ , we have

the following basis (with the generating isometries):

$$L_{(t, 0, 0)} : F_1 = \frac{\partial}{\partial x} + \frac{y}{2} \frac{\partial}{\partial z} .$$

$$L_{(0, t, 0)} : F_2 = \frac{\partial}{\partial y} - \frac{x}{2} \frac{\partial}{\partial z} .$$

$$L_{(0, 0, t)} : F_3 = \frac{\partial}{\partial z} .$$

$$\varrho_\theta : F_4 = -y \frac{\partial}{\partial x} + x \frac{\partial}{\partial y} .$$

Since we know that the $\dim(\mathfrak{S}\mathfrak{S}\mathfrak{O}_0(\mathcal{H}_3, g))$ is at most 4, these four vector fields form the Lie algebra of $\mathfrak{S}\mathfrak{S}\mathfrak{O}_0(\mathcal{H}_3, g)$.

Next, in order to establish the group structure of the product $SO(2) \times \mathcal{H}_3$, let $(\xi, A) \in SO(2) \times \mathcal{H}_3$ and $X \in \mathcal{H}_3$, and let (ξ, A) act on X by $(\xi, A) \cdot X = \xi(L_A(X))$. Then, the product structure on $SO(2) \times \mathcal{H}_3$ is given by

$$(\xi, A) \cdot (\eta, B) = (\xi\eta, (\eta^{-1}A)B) ,$$

where the product on the right component is that of \mathcal{H}_3 . Now, if we define the homomorphism $\varphi: SO(2) \rightarrow \text{Aut}(\mathcal{H}_3)$ by $\varphi(\xi)(A) = \varphi_\xi(A) = \xi^{-1}A$, then it follows that the group structure is that of the semidirect product of $SO(2)$ and \mathcal{H}_3 , where \mathcal{H}_3 is the normal subgroup (cf. [25], pp. 135-138). ■

REMARK. – Using that an isometry of \mathcal{H}_3 which fixes the identity must be an automorphism of \mathfrak{h}_3 , it is possible to show that the *full isometry group* of \mathcal{H}_3 has only one more component, generated by the transformation

$$\varphi = \begin{bmatrix} -1 & 0 & 0 \\ 0 & 1 & 0 \\ 0 & 0 & -1 \end{bmatrix} .$$

THEOREM 2. – *The 1-dimensional closed subgroups of $\mathfrak{S}\mathfrak{S}\mathfrak{O}_0(\mathcal{H}_3, g)$ are:*

1. *The 1-parameter subgroups generated by linear combinations*

$$a_1 F_1 + a_2 F_2 + a_3 F_3 + b F_4$$

of the Killing vector fields, where $b \neq 0$. If $a_i = 0$ for $i \in \{1, 2, 3\}$, we obtain the circle group $SO(2)$ (the only compact subgroup), generated by F_4 .

2. *The 1-parameter subgroups generated by linear combinations of F_1, F_2 and F_3 .* ■

The proof of this theorem is straightforward.

DEFINITION. – The surfaces invariant under subgroups of the first type are called of *helicoidal type*. These include the surfaces of *revolution* (the $SO(2)$ -invariant surfaces). The ones of the second type will be called of *translational type*.

2. – Reduction procedure.

We need some concepts and properties of transformation groups of isometries. The results without references may be found either in [5] or in Chapter 5 of [24]. A closed subgroup G (not necessarily compact) of the isometry group of the Riemannian manifold (M, g) is a Lie group, acting on M by isometries. For $x \in M$, the isotropy subgroup G_x is compact, the quotient space G/G_x is diffeomorphic to the orbit $G(x)$ and $G(x)$ is said to be of *type* (G_x) . $G(y)$ is said to be of *smaller or the same type* as $G(x)$ if G_y contains a conjugate of G_x as a subgroup, written as $(G_y) \leq (G_x)$.

An orbit $G(x)$ is called *principal* if there exists an open neighborhood $U \subset M$ of x such that all orbits $G(y)$, $y \in U$, are of the same type as $G(x)$. This implies that $G(y)$ is canonically diffeomorphic to $G(x)$. Denote by M_r the subset of M of points belonging to principal orbits. These are called *regular points*.

Now, let M/G have the quotient topology and assume it is connected. Then, using that Riemannian actions are proper, we have the *Principal Orbit Theorem* ([23]):

1. There is exactly one type of principal orbit, say (H) , and it is maximal with respect to \leq , i.e., for every $x \in M$, H is conjugate to a subgroup of G_x .

2. M_r is open and dense in M .

3. The quotient space $M_r^* = M_r/G$ is a connected differentiable manifold, and the quotient map is a submersion.

Now let M and N be Riemannian manifolds and G a closed subgroup of the isometry groups of both M and N . Let $\varphi: N \rightarrow M$ be a G -equivariant isometric immersion and suppose that the principal orbit type is the same for both actions. This guarantees that φ passes down to the quotient as an immersion restricted to the regular parts: $\tilde{\varphi}: N_r/G \rightarrow M_r/G$, using the existence of slices. We introduce in the orbit spaces M_r/G and N_r/G the Riemannian metrics which make the quotient maps into Riemannian submersions ([22]).

Since the analysis is local, we consider that N is contained in M , identifying N and $\varphi(N)$. Now let $x \in N_r \subset M_r$, and $H = G_x$. Put an Ad_H -invariant metric on the Lie algebra \mathfrak{g} of G , and consider the orthogonal decomposition $\mathfrak{h} \oplus \mathfrak{h}^\perp$ of \mathfrak{g} with respect to this metric. This gives a G -invariant metric on G/H , and it is clear that \mathfrak{h}^\perp generates $c = \dim G - \dim H$ linearly independent Killing vector fields V_1, \dots, V_c which generate the tangent spaces to the orbits at $y \in U$, a neighborhood of x in M . Let $A(y)$ be the matrix such that $a_{ij} = \langle V_i, V_j \rangle$, the inner product computed in M , and $\omega(y) = (\det A(y))^{1/2}$, which is the volume form of the orbit $G(y)$. The mean curvature vector of φ may be computed in terms of the mean curvature vector of the quotient immersion and this volume function. This result is due to Back, do Carmo and Hsiang ([1]), and is a generalization of the special case of G compact, which has been published in various forms ([17, 16]). The proof is in Appendix A.

REDUCTION THEOREM [1]. – Let H and \tilde{H} be the mean curvature vectors of $N_r \subset M_r$ and $N_r/G \subset M_r/G$, respectively. Then $H = \tilde{H} - \text{grad}(\ln \omega)$.

REMARK. – The mean curvature vector is the trace of the second fundamental form.

If the group G is compact, so that the orbits are compact, then we have the following

COROLLARY [17, 16]. – Let $V(y)$ denote the volume of the orbit $G(y)$, which we think as a function on the orbit space M_r/G . Let \mathbf{n} be a G -invariant unit normal vector field along N_r , which must be horizontal. Let $\tilde{\mathbf{n}}$ be the corresponding normal vector to N_r/G in M_r/G .

Then, $H(\mathbf{n}) = \tilde{H}(\tilde{\mathbf{n}}) - \partial_{\tilde{\mathbf{n}}}(\ln V)$. ■

REMARK. – The full orbit space may contain singularities, due to the non-principal orbits. But in the case we are interested, i.e., for principal orbits of codimension 2, the orbit space is always a manifold, with or without boundary. In this case, the analysis at the boundary (singular orbits) may be carried out, usually conditioned by the differential equations involved, as we shall see in the next sections.

We end this section with a method for the computation of the quotient metric in (the regular part of) the orbit space. It is well-known (cf. [21], ch. 2) that M_r/G may be locally parametrized by invariant functions, obtained from the Killing fields generated by the Lie algebra \mathfrak{g} . Suppose that $\{f_1, f_2, \dots, f_d\}$, $d = \dim M_r/G$, is such a complete set of invariant functions on a G -invariant open subset U of M_r . Denote by \tilde{g} the quotient metric on M_r/G , and define $h_{ij} = \langle \nabla f_i, \nabla f_j \rangle$, computed in M . ∇ is the gradient operator of (M, g) .

QUOTIENT METRIC THEOREM [16]. – The orbital metric is given by $\tilde{g}_{ij} = h^{ij}$, i.e., the length element is $d\tilde{s}^2 = \sum_{i,j=1}^d h^{ij} df_i \otimes df_j$. ■

3. – Helicoidal surfaces (including rotationally invariant surfaces).

We consider here the case where the subgroup of isometries mixes both rotations and translations. Such subgroups are called *helicoidal*. We reduce the possibilities in the following lemma, whose proof is straightforward.

LEMMA 3.1 [11]. – Any surface invariant under a subgroup $G \subset \mathfrak{S}\mathfrak{O}_0(\mathcal{C}_3, g)$ of the form

$$\{L_{(a_1 t, a_2 t, a_3 t)} \circ Q_{bt} : t \in \mathbb{R}\}$$

is isometric to a surface invariant under the subgroup $G = \{L_{(0, 0, at)} \circ Q_t : r \in \mathbb{R}\}$, for some $a \in \mathbb{R}$. ■

The Lie algebra \mathfrak{g} of G is generated by the Killing field $F_4 + aF_3$.

Since the group $SO(2)$ acts on \mathcal{C}_3 by rotations about the z -axis, it is convenient to in-

roduce the usual cylindrical coordinates (r, θ) into \mathbb{R}^3 , with $r \geq 0$ and $\theta \in \mathbb{R}$. Then, the left-invariant metric g takes the form

$$ds^2 = dr^2 + \left(r^2 + \frac{r^4}{4} \right) d\theta^2 + dz^2 - r^2 d\theta dz .$$

Now, taking as invariant functions $u = r$, and $v = z - a\theta$, the orbit space $\mathcal{B} = \mathcal{H}_3/G$ and the orbital metric (cf. Section 2) are given by

$$\mathcal{B} = \{(u, v) \in \mathbb{R}^2: u \geq 0\}, \quad d\tilde{s}^2 = du^2 + \frac{4u^2}{4u^2 + (u^2 + 2a)^2} dv^2 .$$

Next, let $\gamma(s) = (u(s), v(s))$, parametrized by arc-length, be a curve in the orbit space that generates a surface $\Sigma \subset \mathcal{H}_3$ under the action of G . Letting σ be the angle that γ makes with the $\partial/\partial u$ direction, the geodesic curvature of γ is given by ([8], p. 252)

$$(2) \quad k_g = \frac{1}{2 \sqrt{\tilde{g}_{11} \tilde{g}_{22}}} ((\tilde{g}_{22})_u \dot{v} - (\tilde{g}_{11})_v \dot{u}) + \dot{\sigma},$$

where dots denote derivatives with respect to s and subscripts, partial derivatives. We obtain

$$(3) \quad k_g = \dot{\sigma} - \frac{2[u^4 - (2a)^2]}{[4u^2 + (u^2 + 2a)^2]^{3/2}} \dot{v} .$$

The unit tangent and normal vector fields along γ are given by:

$$(4) \quad \begin{cases} \mathbf{t} = \left(\cos \sigma, (2u)^{-1} \sqrt{4u^2 + (u^2 + 2a)^2} \sin \sigma \right), \\ \mathbf{n} = \left(-\sin \sigma, (2u)^{-1} \sqrt{4u^2 + (u^2 + 2a)^2} \cos \sigma \right) \end{cases}$$

and, since G is generated by $F_4 + aF_3$, the volume form $\omega(\xi)$ of a principal orbit ξ is given by

$$\omega(\xi) = \langle F_4 + aF_3, F_4 + aF_3 \rangle^{1/2} = \frac{1}{2} \sqrt{4u^2 + (u^2 + 2a)^2} .$$

The Reduction Theorem (Section 2) takes then following form: the mean curvature H of Σ along a principal orbit ξ is given by $H = k_g - \partial_u \log(\omega(\xi))$. Now, from this, (3) and (4), we obtain the system of ODE's which γ must satisfy:

$$(5) \quad \begin{cases} \dot{u} = \cos \sigma, \\ \dot{v} = (2u)^{-1} \sqrt{4u^2 + (u^2 + 2a)^2} \sin \sigma, \\ \dot{\sigma} = H - u^{-1} \sin \sigma . \end{cases}$$

REMARK. – Notice that the equation for σ has a singularity at the boundary of \mathcal{B} . This type of singularity has been dealt extensively in the literature (cf. Proposition 1 of [16] or the analysis in [9]). In particular, solutions that go to the boundary must enter *perpendicularly*, which means that the generated surface will be *regular* at those points.

From now on, the mean curvature H will be taken constant on Σ . We start the study of equations (5) with the following

PROPOSITION 3.2 [27].

1. Any translate of a solution curve for (5) in the v direction is also a solution curve for (5).

2. Let $\gamma(s)$ be a solution of (5) defined for $s \in (s_0 - \varepsilon, s_0]$, with $\sigma(s_0) = \pm \pi/2$. Then $\gamma(s)$, may be continued to a solution curve defined on the interval $(s_0 - \varepsilon, s_0 + \varepsilon)$ by reflecting across the line $v \equiv v(s_0)$. ■

In fact, item 1. of Proposition 3.2 indicates that there exists a *first integral* for the system of eq. (5). The proof of the next result is straightforward.

PROPOSITION 3.3. – *The function*

$$(6) \quad J(s) = u \sin \sigma - \frac{1}{2} H u^2$$

is constant along a solution $\gamma(s)$ of (5). Thus, the solutions of eq. (5) are characterized by $J(s) \equiv k$, for some $k \in \mathbb{R}$. ■

THEOREM 3. – *The G -invariant constant mean curvature surfaces of \mathcal{H}_3 are, in terms of H and k :*

1. $H \equiv 0$ (minimal surfaces).
 - (a) $k = 0$, which are helicoids, including horizontal planes.
 - (b) $k \neq 0$, surfaces generated by curves of the catenary type.
2. $H > 0$.
 - (a) $k = 0$, including a family of compact surfaces of spherical type.
- (b) $k \neq 0$.
 - (i) Right cylinders of radii H^{-1} .
 - (ii) Surfaces of Delaunay type.

PROOF. – We treat each case separately.

1. $H \equiv 0$. From (6) we get $u \sin \sigma = k$. This gives two possibilities, depending on k .

(a) $k = 0$. We have $\sigma = 0$, and $dv/du = 0$, thus $v = \text{constant}$. Then the surface is given by $z = a\theta$, for $a \in \mathbb{R}$. This minimal surface is a helicoid, such as in Euclidean three space, and its plot is given in figure 1 a).

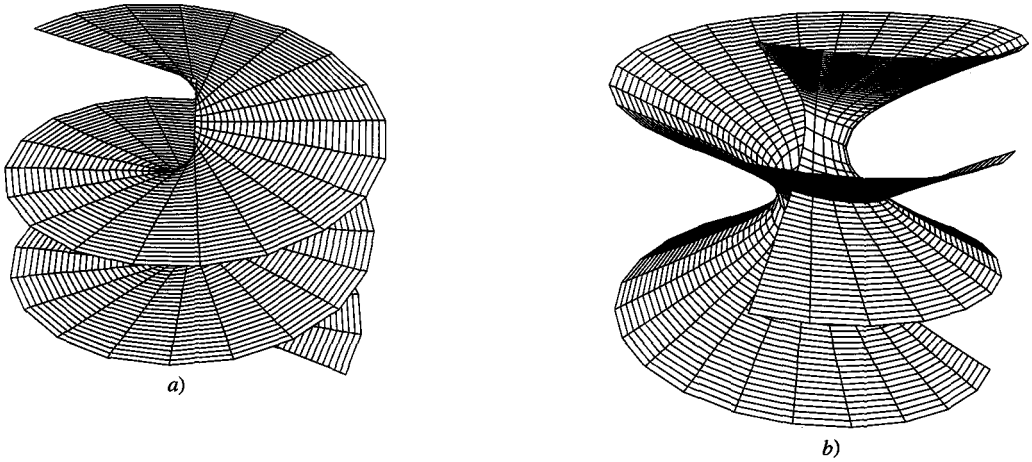

Fig. 1. - a) The helicoid (case 1 a). b) The helicoidal catenoid (case 1 b).

(b) $k > 0$. Here, $\sin \sigma = k/u$, $\cos \sigma = u^{-1} \sqrt{u^2 - k^2}$, thus,

$$(7) \quad \frac{dv}{du} = \frac{k}{2u} \sqrt{\frac{4u^2 + (u^2 + 2a)^2}{u^2 - k^2}}, \quad u > k.$$

Some points deserve attention. The integral for this equation is of elliptic type and (7) is valid if and until u assumes the value k , where the curve becomes parallel to the v direction. Also, $dv/du > 0$, which means that $v(u)$ is increasing and, finally, $\lim_{u \rightarrow +\infty} dv/du = k/2$. Therefore, according to Proposition (3.2), we may consider the unique solution of (5) determined by the initial conditions

$$u(0) = k, \quad v(0) = 0, \quad \sigma(0) = \frac{\pi}{2},$$

by reflecting across the line $v = 0$. These curves are of the *catenary* type. If $a = 0$, we obtain an exact analogous to the *catenoid*. If $a = -1/2$, (7) may be explicitly integrated. By doing that and substituting back the invariant functions, we obtain a minimal surface of helicoidal type of equation (in cylindrical coordinates)

$$z(r, \theta) = -\frac{1}{2} \theta - \frac{1}{2} \arcsin(kr^{-1}) + \frac{k}{2} \sqrt{r^2 - k^2},$$

with $r \geq k$. A plot of this surface, which we call *helicoidal catenoid*, is given in figure 1 b).

2. $H > 0$.

(a) $k = 0$. From (6) we have $u \sin \sigma - Hu^2/2 = 0$. Then $\sin \sigma = Hu/2$, $\cos \sigma = \sqrt{4 - Hu^2}/2$. Thus,

$$\frac{dv}{du} = \frac{H}{2} \sqrt{\frac{4u^2 + (u^2 + 2a)^2}{4 - H^2u^2}},$$

with $u \in [0, 2H^{-1})$. We again remark that this equation is of elliptic type and is valid if and until u assumes the value $2/H$, where the curve becomes parallel to the v direction. Also, if $u = 0$ we have $\sigma = 0$, i.e. γ is parallel to the u direction and $dv/du > 0$, i.e., $v(u)$ is increasing. For some choices of a , this equation may again be integrated.

(i) $a = 0$: we have,

$$\frac{dv}{du} = \frac{Hu}{2} \sqrt{\frac{4 + u^2}{4 - H^2u^2}},$$

with $u \in [0, 2H^{-1})$. Integrating, we get

$$z(r, \theta) = v(u) = \frac{1}{4H} \sqrt{(4 + r^2)(4 - H^2r^2)} + \frac{1 + H^2}{H^2} \arcsin \frac{1}{2} \sqrt{\frac{4 - H^2r^2}{1 + H^2}}.$$

Observe, in this case, that the curve γ generates a compact surface with mean curvature H . A plot of an example of such a surface is given in figure 2 a).

(ii) $a = -1/2$: the surface is of helicoidal type, with generating curve γ , in this case, characterized by the differential equation

$$\frac{dv}{du} = \frac{H}{2} \left(\frac{1 + u^2}{\sqrt{4 - H^2u^2}} \right), \quad u \in [0, 2H^{-1}).$$

By integrating this, and substituting back the invariant functions, we get the following

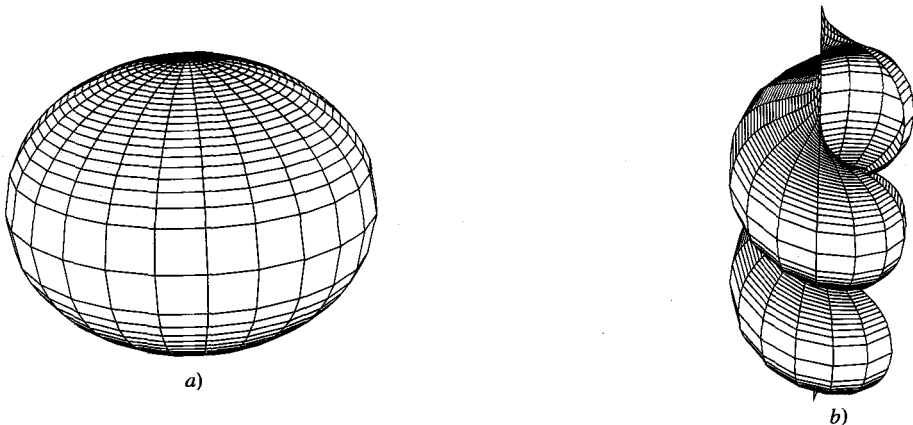

Fig. 2. - Compact surface, $H = 1$ (case 2 a i). b) Case 2 a ii, with $a = -1/2$, $H = 1$.

equation in cylindrical coordinates:

$$z(r, \theta) = -\frac{1}{2}\theta + \frac{2 + H^2}{2H^2} \arcsin \frac{Hr}{2} - \frac{r\sqrt{4 - H^2r^2}}{4H},$$

with $r \in [0, 2H^{-1}]$. A plot of such a surface is given in fig. 2 b).

(b) $k \neq 0$. From (6) we have

$$u = \frac{1}{H} \left(\sin \sigma \pm \sqrt{\sin^2 \sigma - 2kH} \right).$$

It follows that $k \leq (2H)^{-1}$. Then

(i) If $k = (2H)^{-1}$, we obtain that $\sigma \equiv \pi/2$. It follows that $r \equiv H^{-1}$, the right cylinder.

(ii) If $k < (2H)^{-1}$, we can repeat the analysis of P. Tompter in [27] to conclude that the generating curves are unduloids and nodoids, and the corresponding surfaces are of Delaunay type. ■

DEFINITION. – Let $U \subset \{(x, y, z) \in \mathcal{H}_3 : z = 0\}$ and $f: U \rightarrow \mathbb{R}$. The graph $\Gamma(U, f)$ of f (over U) in \mathcal{H}_3 is the graph $\{(x, y, f(x, y)) : (x, y, 0) \in U\}$, in exponential coordinates for \mathcal{H}_3 . A graph $\Gamma(U, f)$ is called *complete* if U is the whole plane $z = 0$.

As a corollary to the existence of compact solutions for each value of nonzero mean curvature (when $\alpha = 0$ in subcase 2a, i.e., the $SO(2)$ -invariant spheres, as in fig. 5), we will show

THEOREM 4. – *There are no complete graphs of nonzero constant mean curvature in \mathcal{H}_3 .*

PROOF. – Denote the surface of spherical type given by item 2.(a) of Theorem 3, of constant mean curvature H , by $S(H)$. We will use the fact that the translation in the z -axis direction is an isometry, together with a suitable version of the maximum principle. For a graph, let the unit normal vector be chosen such that it points downward with respect to the z -axis. We say, for two graphs Σ_1 and Σ_2 , given by $\phi_1: U \rightarrow \mathbb{R}$ and $\phi_2: U \rightarrow \mathbb{R}$, $U \subset \mathbb{R}^2$, respectively, that $\Sigma_1 \geq \Sigma_2$ on U if $\phi_1(x) \geq \phi_2(x)$ for $x \in U$. Then we have

LEMMA 3.4 (Maximum principle). – *Let Σ_1 and Σ_2 be two hypersurfaces of \mathcal{H}_3 that are graphs over an open connected set V of the plane x, y , with a common point P_0 and suppose that the tangent spaces to Σ_1 and Σ_2 at P_0 coincide. Suppose that the mean-curvature functions satisfy $H_1 = H_2$ on a neighborhood U of P_0 . If $\Sigma_1 \geq \Sigma_2$ on U , then $\Sigma_1 = \Sigma_2$ on V .*

This follows from an application of Hopf's maximum principle (cf. Chapter 3 of [12]) as in Lemma 1 of [26].

Now, let $\Gamma(f)$ be a complete graph of constant mean curvature $H > 0$ in \mathcal{H}_3 (the case $H < 0$ is treated similarly). Let $\Sigma = S(H)$, centered at the origin of the exponential co-

ordinates ($S(H)$ is center-symmetric). Denote by Σ_+ the part of Σ with positive z coordinate. Now, since the translation along the z -axis is an isometry, we may move Σ_+ down the z -direction until the intersection with Γ is empty and then make it touch, in such a way that the unit normal vectors coincide. Then, by the maximum principle given above, Σ and Γ must coincide. ■

4. - Surfaces invariant under translations.

We consider here the surfaces invariant under subgroups $G \subset \mathfrak{S}\mathfrak{o}_0(\mathcal{H}_3, g)$ of type $\{L_{(a_1t, a_2t, a_3t)}\}$, with $a_i \neq 0$ for some $i \in \{1, 2, 3\}$.

LEMMA 4.1 [11]. - *Let Σ be G -invariant. If $a_i \neq 0$ for some $i \in \{1, 2\}$, then Σ is isometric to a surface invariant under the subgroup $G = \{L_{(t, 0, 0)}: t \in \mathbb{R}\}$. ■*

Notice that this lemma does not provide for the case when the group is of the form $\{L_{(0, 0, at)}: t \in \mathbb{R}\}$. We treat this case first.

THEOREM 5. - *The constant mean surfaces of \mathcal{H}_3 invariant under $G = \{L_{(0, 0, t)}: t \in \mathbb{R}\}$ are*

1. *The vertical planes ($H = 0$).*
2. *The vertical right cylinders with radii H^{-1} (measured in the Euclidean metric).*

PROOF. - The subgroup G is given by the z -translations. Thus, we apply the reduction procedure with the G -invariant functions $u = x, v = y$. Straightforward calculations show that the quotient metric in $\mathcal{B} = \mathbb{R}^2$ is just the Euclidean metric ($\nabla u = E_1, \nabla v = E_2$). Then, since the volume element of the orbits is constant ($\omega = \langle E_3, E_3 \rangle = 1$), the mean curvature H of a G -invariant surface Σ is given by the geodesic curvature k_γ of a generating curve γ for Σ . But in the Euclidean plane the only curves of constant geodesic curvatures are lines ($H = k_\gamma \equiv 0$) and circles ($H = k_\gamma \equiv \text{constant} \neq 0$). ■

Next, we apply Lemma 4.1 and consider the one-dimensional subalgebra generated by F_1 , which is the Lie algebra of the subgroup of isometries given by the left translations of the form $G = \{L_{(t, 0, 0)}: t \in \mathbb{R}\}$. Applying the general theory of invariants (cf. [21], chapter 2), the characteristic system for

$$\frac{\partial \xi}{\partial x} + \frac{y}{2} \frac{\partial \xi}{\partial z} = 0$$

is given by $u dx/2 = dz$, and it follows that $xy/2 - z = \text{constant}$. Thus, the invariant functions are

$$u(x, y, z) = y, \quad v(x, y, z) = xy/2 - z.$$

The quotient space $\mathcal{B} = \mathcal{X}_3/G$ and the quotient metric are

$$\mathcal{B} = \mathbb{R}^2, \quad d\tilde{s}^2 = du^2 + \frac{1}{1+u^2} dv^2.$$

THEOREM 6. - *The G-invariant constant mean curvature surfaces of \mathcal{X}_3 are:*

1. $H \equiv 0$.

(a) *The surfaces of equation*

$$z = \frac{xy}{2} - c \left[\frac{y\sqrt{1+y^2}}{2} + \frac{1}{2} \ln(y + \sqrt{1+y^2}) \right], \quad c \in \mathbb{R}.$$

(b) *The vertical planes.*

2. $H \neq 0$.

The surfaces of equation

$$z = \frac{xy}{2} \pm \frac{1}{2H} \left(\sqrt{1+y^2} \sqrt{1-H^2y^2} + \frac{1+H^2}{H} \arcsin \sqrt{\frac{1-H^2y^2}{1+H^2}} \right), \quad -\frac{1}{H} \leq y \leq \frac{1}{H}.$$

PROOF. - In order to apply the formula given by the Reduction Theorem (Section 2), we again compute the geodesic curvature of the curve $\gamma(s) = (u(s), v(s))$ generating the surface. Let σ be the angle that γ makes with the direction $\partial/\partial v$. Using eq. (2), the geodesic curvature of γ in terms of σ is given by

$$k_g = \dot{\sigma} + \frac{u \cos \sigma}{1+u^2}.$$

The volume element $\omega(\xi)$ of a principal orbit xi is given by

$$\omega(\xi) = \langle F_1, F_1 \rangle^{1/2} = \langle E_1 + yE_3, E_1 + yE_3 \rangle^{1/2} = \sqrt{1+y^2}.$$

The positively oriented unit normal to γ is

$$\mathbf{n} = -\sin \sigma \sqrt{1+u^2} \frac{\partial}{\partial v} + \cos \sigma \frac{\partial}{\partial u}.$$

Then $\partial_n(\ln \omega) = u \cos \sigma / (1+u^2)$, and as $H = k_g - \partial_n(\ln \omega)$, we get $H = \dot{\sigma}$. Summing up, we get the system

$$\begin{cases} \dot{u}(s) = \sin \sigma, \\ \dot{v}(s) = \sqrt{1+u^2} \cos \sigma, \\ \dot{\sigma}(s) = H. \end{cases}$$

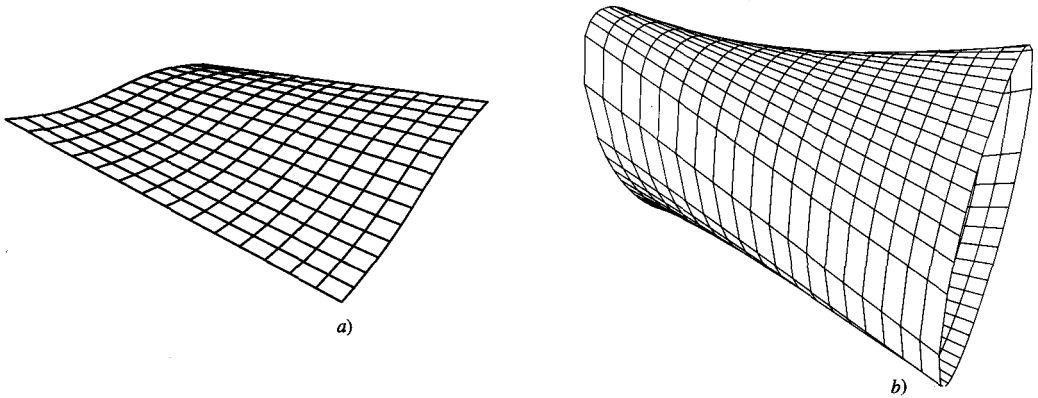

Fig. 3. - a) Case 1 a: minimal surface, $r = 1$. b) Case 2, $H = 1$.

1. $H \equiv 0$. In this case $\dot{\sigma}(s) = 0$, which implies that $\sigma(s) = k$, thus $\dot{u}(s) = \sin k$ and $\dot{v}(s) = \sqrt{1 + u^2} \cos k$. Again we separate the two possibilities for k .

(a) $k \neq 0, \neq \pi$. We have $dv = \cot k \sqrt{1 + u^2} du$. By integrating and substituting back the invariant functions, and letting $c = \cot k$, the result follows. Figure 3 a) shows a minimal surface of this type, with $r = 1$.

(b) $k = 0, \pi$. We have $\dot{u}(s) = 0$, thus $u(s) \equiv \text{constant}$. That is, the surfaces are vertical planes.

2. $H > 0$. In this case $\sigma(s) = Hs + a$ and $\dot{u}(s) = \sin(Hs + a)$, thus $u(s) = -H^{-1} \cos(Hs + a)$. It follows that

$$\begin{cases} \cos \sigma = -Hu, \\ \sin \sigma = \pm \sqrt{1 - H^2 u^2}. \end{cases}$$

Then $dv = \mp Hu \sqrt{(1 + u^2)(1 - H^2 u^2)^{-1}} du$. The result follows from integration and substitution of the invariant functions. Figure 3b) shows an example of such a surface. ■

5. - Higher dimensional Heisenberg groups.

The results of Theorem 3 for $a = 0$, i.e. for the $SO(2)$ -invariant surfaces, may be generalized directly to the higher dimensional Heisenberg group H_{2n+1} , given by the upper triangular real matrices of order $2n + 1$ with 1's on the diagonal.

Similarly to the case $n = 1$, by using exponential coordinates, $a_i, b_j, c, i, j = 1, \dots, n$, we identify H_{2n+1} with \mathbb{R}^{2n+1} . Then, the group product is given by

$$X_1 \star X_2 = (x_{11}, y_{11}, \dots, x_{1n}, y_{1n}, z_1) \star (x_{21}, y_{21}, \dots, x_{2n}, y_{2n}, z_2) = X_1 + X_2 + L(X_1) \cdot X_2,$$

where

$$L(X_1) = \begin{bmatrix} 0 & \cdots & 0 & 0 & \cdots & 0 & 0 \\ \vdots & & \vdots & \vdots & & \vdots & \vdots \\ 0 & \cdots & 0 & 0 & \cdots & 0 & 0 \\ -\frac{y_{11}}{2} & \cdots & -\frac{y_{1n}}{2} & \frac{x_{11}}{2} & \cdots & \frac{x_{1n}}{2} & 0 \end{bmatrix}.$$

We will use this identification in this section.

Now, it is easy to see that the left-invariant metric g , which takes the usual basis of the Lie algebra \mathfrak{h}_{2n+1} to be orthonormal, is given by

$$ds^2 = \sum_{i=1}^n (dx_i^2 + dy_i^2) + \left[dz + \frac{1}{2} \sum_{i=1}^n (y_i dx_i - x_i dy_i) \right]^2.$$

The information we need about $\mathfrak{S}\mathfrak{S}\mathfrak{o}(H_{2n+1}, g)$ is given by

THEOREM 7 [18, 11]. – *The isometry group $\mathfrak{S}\mathfrak{S}\mathfrak{o}(H_{2n+1}, g)$ is given by the semidirect product of H_{2n+1} and the subgroup K of the automorphism group $\text{Aut}(H_{2n+1})$ which leaves the inner product in the Lie algebra \mathfrak{h}_{2n+1} invariant. Moreover, K is compact and acts linearly in $H_{2n+1} (\cong \mathbb{R}^{2n+1})$, fixing the z -direction, which is the center of H_{2n+1} , and the regular part of the orbit space $B = H_{2n+1}/K$ is of dimension 2*

K is in fact a subgroup of $SO(2n)$ acting transitively on the $(2n - 1)$ -spheres with centers on the z axis, so that we use cylindrical coordinates again. Thus, we take as K -invariant functions

$$\begin{aligned} t(x_1, \dots, x_n, y_1, \dots, y_n, z) &= z, \\ r(x_1, \dots, x_n, y_1, \dots, y_n, z) &= \sum_{i=1}^n x_i^2 + y_i^2, \end{aligned}$$

and the orbit space and orbital metric are given by

$$B = \{(t, r) \in \mathbb{R}^2: r \geq 0\}, \quad d\tilde{s}^2 = \frac{4}{4 + r^2} dt^2 + dr^2.$$

The K -invariant hypersurfaces will be called *rotational* hypersurfaces.

Now, letting σ as the angle between the tangent to a curve γ , parametrized by arc-

length, and the $\partial/\partial t$ direction, we obtain the following system of equations for γ :

$$\begin{cases} \dot{t} = \frac{1}{2} \sqrt{4 + r^2} \cos \sigma, \\ \dot{r} = \sin \sigma, \\ \dot{\sigma} = H + \frac{2n-1}{r} \cos \sigma, \end{cases}$$

where H is the mean curvature of the hypersurface of H_{2n+1} generated by γ under the action of K . The deduction of these equations is analogous to the case in Section 3. Also, we again obtain a *first integral*: the function

$$J(s) = r^{2n-1} \cos \sigma + \frac{H}{2n} r^{2n}$$

is constant along solutions. Using this and proceeding along the lines of the proof of Theorem 3, we have the following

THEOREM 8. - *The rotational hypersurfaces of constant mean curvature H of H_{2n+1} are:*

1. $H = 0$.
 - (a) *Horizontal hyperplanes $z = \text{constant}$.*
 - (b) *Hypersurfaces of catenoidal type.*
2. $H \neq 0$.
 - (a) *Spherical hypersurfaces generated by*

$$t(r) = \frac{\sqrt{(4+r^2)(4n^2-H^2r^2)}}{4H} + \frac{n^2+H^2}{H^2} \arcsin \frac{1}{2} \sqrt{\frac{4n^2-H^2r^2}{n^2+H^2}},$$

where $r \in [0, 2nH^{-1}]$.

(b) *Hypersurfaces of the Delaunay type, generated by unduloids and nodoids.* ■

Using item 2a) of Theorem 8, it is easy to show that Theorem 4 is also true in higher dimensions, i.e., there are no complete graphs of nonzero constant mean curvature in H_{2n+1} , where by a graph we mean the graph of a function $z = f(x_1, \dots, x_n, y_1, \dots, y_n)$. The proof is the same as before.

6. - Final comments.

1. The family of spherical surfaces given by Theorem 3.2 (a), with $a = 0$, furnishes a family of increasing volume balls. These are natural candidates for solutions to the *isoperimetric problem* in H_3 . Analogously in higher dimensions. Even proving the *stability* of these surfaces (as constant mean curvature surfaces [2]) is an interesting

problem, and one for which the usual eigenvalue technique is not easily available. Also, since the reflections about vertical planes are not isometries, the usual symmetry and symmetrization techniques are not available either (cf. [27]).

2. It is easy to show that any plane in $H_3 (\cong \mathbb{R}^3)$ is minimal, not only the vertical and horizontal, as we have obtained. Also, there are other graphs in H_3 which are minimal, as in Theorem 6.1 (a). This shows that a *Bernstein type theorem* for H_3 should have a different formulation, that of giving a complete classification for the minimal graphs in H_3 . This is the subject of a forthcoming paper by the first author ([10]), where a minimal graph is studied in terms of the rank of its Gauss map. The same problem may be studied for the higher dimensional Heisenberg groups.

3. The helicoidal catenoid in Theorem 3.1 (b) looks very much like one of the steps of the deformation from the catenoid to the helicoid in \mathbb{R}^3 (cf. [8], p. 223) given by the Weierstrass representation. Is there a similar phenomenon occurring here? Is the family given in Theorem 3.1 given by a deformation of locally isometric minimal surfaces?

4. In [6], the authors study surfaces of constant Gauss curvature in H_3 which are invariant under $SO(2)$. The techniques developed here could be used to extend those results to the other 1-dimensional subgroups of $\mathfrak{S}\mathfrak{B}_0(H_3, g)$ and also to higher dimensions.

5. It is well-known that the classical Delaunay surfaces (including the catenoid and the spheres) in \mathbb{R}^3 may be obtained by rotating about a line (the axis of revolution) the curves generated in the plane by the foci of conic sections which move without sliding along the line. What are the analogous curves for the Delaunay type surfaces we have obtained in H_3 ? It is a simple interesting geometrical problem in \mathbb{R}^2 .

A. Appendix: Proof of the Reduction Theorem.

The O'Neill tensors of a Riemannian submersion $\pi: E \rightarrow B$ is a Riemannian submersion are defined as

$$\mathfrak{A}(X, Y) = (\nabla_{X^h} Y^h)^v + (\nabla_{X^h} Y^v)^h,$$

$$\mathfrak{B}(X, Y) = (\nabla_{X^v} Y^h)^v + (\nabla_{X^v} Y^v)^h$$

where h and v denote the horizontal and vertical projections, respectively.

A vector field X is said to *projectable* if it is horizontal and, if $x, y \in \pi^{-1}(b)$, $d\pi_x(X(x)) = d\pi_y(X(y))$. In the case of the map π is the quotient map given by a Riemannian action (in the regular part), then projectable means horizontal and invariant.

LEMMA A.1 [22]. - *Suppose that X is a vertical vector field and Y is projectable. Then*

1. $[X, Y]$ is vertical.
2. If X is Killing, then $[X, Y] = 0$. ■

LEMMA A.2 [22].

1. \mathcal{A} and \mathcal{C} are 2-tensors.
2. They interchange the vertical and horizontal spaces at each point.
3. $\mathcal{A}_X = \mathcal{A}(X, \cdot)$ and $\mathcal{C}_X = \mathcal{C}(X, \cdot)$ are anti-symmetric operators on $T_x E$ with respect to the Riemannian inner product.
4. If X, Y are projectable, then $\mathcal{A}(X, Y) = -\mathcal{A}(Y, X)$.
5. If X, Y are vertical, then $\mathcal{C}(X, Y) = \mathcal{C}(Y, X)$. ■

Now, suppose that G acts by isometries on M , $\dim M = m$, and let H_1, \dots, H_d be a projectable orthonormal frame for the horizontal part of $\pi: M_r \rightarrow M_r/G$, in some G -invariant neighborhood U of $x \in M_r$. Let also V_1, \dots, V_c , $c = \dim G/G_x$, be a local frame of Killing vector fields for the vertical part, around x , as in Section 2. The O'Neill tensors, in terms of this frame around x , are given next.

PROPOSITION A.3 [22, 1].

1. $\mathcal{A}(H_i, H_j) = 1/2[H_i, H_j]^v$.
2. $\langle \mathcal{C}(V_i, V_j), H_k \rangle = - (1/2) H_k \langle V_i, V_j \rangle = - (1/2) H_k(a_{ij})$.

PROOF. – The first claim follows from the definitions and part 4 of Lemma A.2. For the second, we use Lemma A.1.2 and compute

$$\begin{aligned} H_k \langle V_i, V_j \rangle &= \langle \nabla_{H_k} V_i, V_j \rangle + \langle V_i, \nabla_{H_k} V_j \rangle = \langle \nabla_{V_i} H_k, V_j \rangle + \langle V_i, \nabla_{V_j} H_k \rangle = \\ &= - \langle H_k, \nabla_{V_i} V_j + \nabla_{V_j} V_i \rangle = - 2 \langle H_k, \nabla_{V_i} V_j \rangle, \end{aligned}$$

where we used Lemma A.2.5 for the last line. But this is just the H_k -component of $\mathcal{C}(V_i, V_j)$. ■

The next result gives the relationships between the connections ∇ of M , ∇^v of the orbits and ∇^h of M_r/G , and the O'Neill tensors, in terms of the special frame used above. We identify the horizontal vector fields with their projections.

PROPOSITION A.4 [1].

1. $\nabla_{V_i} V_j = \mathcal{C}(V_i, V_j) + \nabla_{V_i}^v V_j$.
2. $\nabla_{V_i} H_j = \nabla_{H_j} V_i = \mathcal{C}(V_i, H_j) + \mathcal{A}(V_i, V_j)$.
3. $\nabla_{H_i} H_j = \mathcal{A}(H_i, H_j) + \nabla_{H_i}^h H_j$.

PROOF. – These equations follow directly from the definitions, using the fact that $[V_i, H_j] = 0$ for the second part. ■

We now proceed to apply these equations to the case of a G -equivariant isometric immersion $\varphi: N \rightarrow M$, $\dim N = n$. Let $\pi: N_r \rightarrow N_r/G$ and $\pi': M_r \rightarrow M_r/G$ be the regular submersions. The assumption that the principal orbits of both actions is the same

implies that φ passes down to the quotients as an isometric immersion

$$\widehat{\varphi}: N_r/G \rightarrow M_r/G,$$

if N_r/G and M_r/G are given the submersion metrics. We now consider the restriction to M_r and N_r in all that follows. Denote by II and \widehat{II} the second fundamental forms of φ and $\widehat{\varphi}$, respectively. Denote by

- \mathcal{A}, \mathcal{C} , the O'Neill tensors for π ,
- $\mathcal{A}', \mathcal{C}'$, the O'Neill tensors for π' ,
- ∇ , the connection of N ,
- ∇' , the connection of M ,
- $\widehat{\nabla}$, the connection of N_r/G ,
- $\widehat{\nabla}'$, the connection of M_r/G .

Also, denote by X^\top and X^\perp the tangent and orthogonal projections along both immersions. Again we treat N_r and N_r/G as submanifolds contained in the ambient spaces, since the arguments are local.

We write the second fundamental form tensors, in a way similar to the tensor \mathcal{C} , as:

$$II(X, Y) = (\nabla_{X^\top}^\perp Y^\top)^\perp + (\nabla_{X^\top} Y^\perp)^\top,$$

$$\widehat{II}(X, Y) = (\widehat{\nabla}_{X^\top}^\perp Y^\top)^\perp + (\widehat{\nabla}_{X^\top} Y^\perp)^\top,$$

where X, Y are vector fields along N_r for the first, and along N_r/G for the second equation. Now we specify the adapted frame field which we will use (see fig. 4). As before, we use a vertical frame of Killing vector fields $\{V_1, \dots, V_c\}$, which we take to be the same for both actions, since the principal orbits coincide. The horizontal projectable frame field, we decompose into two sets: the first e orthonormal fields H_1, \dots, H_e , for $c + e = n$, the dimension of N , we take to be tangent to the submanifold $N_r \subset M_r$. Their

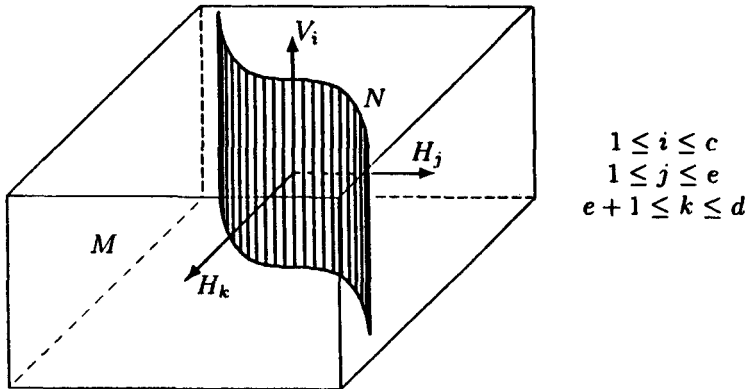

Fig. 4. - Special frame.

projections are also tangent to $N_r/G \subset M_r/G$. The remaining E_{e+1}, \dots, H_d complete the horizontal part, being orthogonal to N_r (and to N_r/G).

The next proposition gives the relationships between the second fundamental tensors and the O'Neill tensors.

PROPOSITION A.5 [1].

1. For $1 \leq i, j \leq e$, $\mathcal{A}(H_i, H_j) = \mathcal{A}'(H_i, H_j)$.
2. $II(V_i, V_j) = \mathcal{T}'(V_i, V_j) - \mathcal{T}(V_i, V_j)$.
3. For $1 \leq i, j \leq e$, $II(H_i, H_j) = II(H_i, H_j)$.
4. For $1 \leq i \leq e$, $II(H_i, V_j) = II(V_j, H_i) = \mathcal{A}'(H_i, V_j) - \mathcal{A}(H_i, V_j)$.

PROOF.

1. We have $\mathcal{A}(H_i, H_j) = (1/2)[H_i, H_j]^v$; since the vertical part is the same, we must also have $\mathcal{A}'(H_i, H_j) = (1/2)[H_i, H_j]^v$.

2. We compute

$$\begin{aligned} II(V_i, V_j) &= (\nabla'_{V_i} V_j)^\perp = \nabla'_{V_i} V_j - \nabla_{V_i} V_j = \\ &= \mathcal{T}'(V_i, V_j) + \nabla_{V_i}^v V_j - \mathcal{T}(V_i, V_j) - \nabla_{V_i}^v V_j \quad (\text{using A.4.1}) \\ &= \mathcal{T}'(V_i, V_j) - \mathcal{T}(V_i, V_j), \end{aligned}$$

since the vertical connections coincide.

3. This follows from the fact that $d\pi$ is an isometry when restricted to the horizontal distribution, and the second fundamental tensors are horizontal and normal for horizontal and tangent fields to the submanifolds.

4. We compute

$$\begin{aligned} II(H_i, V_j) &= (\nabla'_{H_i} V_j)^\perp = \nabla'_{H_i} V_j - \nabla_{H_i} V_j = \\ &= \mathcal{T}'(V_j, H_i) + \mathcal{A}'(H_i, V_j) - \mathcal{T}(V_j, V_i) - \mathcal{A}(H_i, V_j) \quad (\text{using A.4.3}) \\ &= \mathcal{A}'(H_i, V_j) - \mathcal{A}(H_i, V_j). \end{aligned}$$

For the last line, notice that $\mathcal{T}(V_j, H_i)$ and $\mathcal{T}'(V_j, H_i)$ are vertical, and that

$$\langle \mathcal{T}(V_j, H_i), V_k \rangle = - \langle H_i, \mathcal{T}(V_j, V_k) \rangle,$$

$$\langle \mathcal{T}'(V_j, H_i), V_k \rangle = - \langle H_i, \mathcal{T}'(V_j, V_k) \rangle.$$

But \mathcal{T} and \mathcal{T}' both represent the second fundamental tensors of the orbits, inside N and M , respectively. Since H_i is tangent to N , they coincide. ■

PROOF OF THE REDUCTION THEOREM. – Let $\{X_1, \dots, X_c\}$ be a local orthonormal vertical frame field. Then

$$\text{tr } II = \sum_{i=1}^c II(X_i, X_i) + \sum_{i=1}^e II(H_i, H_i),$$

using the previously chosen adapted horizontal frame field. From Prop. A.5.3, the second term on the right hand side of this equation is just $\text{tr } \tilde{II}$. Thus, it remains to compute the first term. Now notice that, since the second fundamental tensors are normal to the submanifolds when computed on tangent fields, it is only necessary to compute the projections in the normal directions. We use a normal projectable frame field H_r , for $r > e$. Recall that we have defined the matrix $A = (a_{ij})$ by $a_{ij} = \langle V_i, V_j \rangle$ and $\omega = (\det A)^{1/2}$. Now let $V_i = \sum_{s=1}^c \alpha_{is} X_s$. Then $a_{ij} = \sum_{s=1}^c \alpha_{is} \alpha_{js}$. By Proposition (A.5.2), we know how to compute this sum using the frame of Killing fields $\{V_1, \dots, V_c\}$. Let $X_i = \sum_{j=1}^c \alpha^{ij} V_j$, where (α^{ij}) is the inverse of (a_{ij}) . Then

$$\sum_{i=1}^c II(X_i, X_i) = \sum_{i,j,r=1}^c \alpha^{ij} \alpha^{ir} II(V_j, V_r).$$

Projecting with respect to H_k , we get

$$\begin{aligned} \left\langle \sum_{i=1}^c II(X_i, X_i), H_k \right\rangle &= \sum_{i,j,r=1}^c \alpha^{ij} \alpha^{ir} \langle II(V_j, V_r), H_k \rangle = \\ &= -\frac{1}{2} \sum_{i,j,r=1}^c \alpha^{ij} \alpha^{ir} H_k \langle V_j, V_r \rangle = -\frac{1}{2} \sum_{j,r=1}^c H_k a_{jr} \sum_{i=1}^c \alpha^{ij} \alpha^{ir} = \\ &= -\frac{1}{2} \sum_{j,r=1}^c \alpha^{jr} H_k a_{jr} = -\frac{1}{2} H_k [\ln \det (a_{ij})]. \end{aligned}$$

The result follows. ■

REFERENCES

- [1] A. BACK - M. P. DO CARMO - W.-Y. HSIANG, *On the fundamental equations of equivariant geometry* (unpublished manuscript).
- [2] J. L. BARBOSA - M. DO CARMO - J. ESCHENBURG, *Stability of hypersurfaces of constant mean curvature in Riemannians manifolds*, *Math. Z.*, **197** (1988), pp. 123-138.
- [3] M. BEKKAR, *Exemples de surfaces minimales dans l'espace de Heisenberg H_3* , *Rend. Sem. Sci. Univ. Cagliari*, **61** (1991), no. 2, pp. 123-130.
- [4] M. BEKKAR - T. SARI, *Surfaces minimales réglées dans l'espace de Heisenberg H_3* , *Rend. Sem. Mat. Univ. Pol. Torino*, **50** (1992), no. 3, pp. 243-254.
- [5] G. BREDON, *Introduction to Compact Transformation Groups*, Academic Press, New York (1972).

- [6] R. CADDEO - P. PIU - A. RATTO, *Rotational surfaces in H_3 with constant Gauss curvature*, preprint.
- [7] R. CADDEO - P. PIU - A. RATTO, *$SO(2)$ -invariant minimal and constant mean curvature surface in 3-dimensional homogeneous spaces*, *Manusc. Math.*, **87** (1995), pp. 1-12.
- [8] M. P. DO CARMO, *Differential Geometry of Curves and Surfaces*, Prentice-Hall, Englewood Cliffs (1976).
- [9] J. EELLS - A. RATTO, *Harmonic Maps and Minimal Immersions with Symmetries*, *Ann. of Math. Studies*, **130**, Princeton Univ. Press, Princeton (1992).
- [10] CH. FIGUEROA, *The Gauss map of minimal surfaces in the Heisenberg group*, in preparation.
- [11] CH. FIGUEROA, *Geometria das subvariedades do grupo de Heisenberg*, Ph.D. thesis, Unicamp (1996).
- [12] D. GILBARG - N. S. TRUDINGER, *Elliptic Partial Differential Equations of Second Order*, Springer-Verlag, New York (1983).
- [13] W. M. GOLDMAN, *Complex Hyperbolic Geometry*, Book, to appear.
- [14] M. GOZE - P. PIU, *Classification des métriques invariantes à gauche sur le groupe de Heisenberg*, *Rend. Circ. Mat. Palermo*, **XXXIX-II** (1990), pp. 299-306.
- [15] M. GROMOV, *Carnot-Carathéodory spaces seen from within*, Tech. Report M/94/6, IHES (1994).
- [16] W.-T. HSIANG - W.-Y. HSIANG, *On the existence of codimension one minimal spheres in compact symmetric spaces of rank 2*, *J. Diff. Geom.*, **17** (1982), pp. 583-594.
- [17] W.-Y. HSIANG - H. B. LAWSON Jr., *Minimal submanifolds of low cohomogeneity*, *J. Diff. Geom.*, **5** (1971), pp. 1-38.
- [18] A. KAPLAN, *Riemannian nilmanifolds attached to Clifford modules*, *Geom. Dedicata*, **11** (1981), pp. 127-136.
- [19] S. KOBAYASHI, *Transformation Groups in Differential Geometry*, *Ergebnisse der Mathematik* 70, Springer-Verlag, New York (1972).
- [20] S. KOBAYASHI - K. NOMIZU, *Foundations of Differential Geometry I/II*, *Tracts in Mathematics* 15, Interscience, New York (1963).
- [21] P. J. OLVER, *Applications of Lie Groups to Differential Equations*, *GTM* 107, Springer-Verlag, New York (1986).
- [22] B. O'NEILL, *The fundamental equations of a submersion*, *Mich. Math. J.*, **13** (1966), pp. 459-469.
- [23] R. S. PALAIS, *On the existence of slices for actions of non-compact Lie groups*, *Ann. of Math.*, **73** (1961), pp. 295-323.
- [24] R. S. PALAIS - C.-L. TERNG, *Critical Point Theory and Submanifold Theory*, *LNM* 1353, Springer-Verlag, New York (1980).
- [25] J. ROTMAN, *The Theory of Groups, an Introduction*, *Series in advanced mathematics*, Allyn and Bacon, Boston (1973).
- [26] R. SCHOEN, *Uniqueness, symmetry and embeddedness of minimal surfaces*, *J. Diff. Geom.*, **18** (1983), pp. 791-809.
- [27] P. TOMPTER, *Constant mean curvature surfaces in the Heisenberg group*, *Proc. of Symp. Pure Math.*, **54** (1993), pp. 485-495.