

Study on Irrigation Regime of Double Cropping of Winter Wheat with Summer Maize

Wang Shengfeng, Xu Jianxin, Yang Shuqin, and Jia Ping

North China University of Water Resources and Electric Power, Zhenzhou, P.R. China
Wangsf1234@sina.com

Abstract. Winter wheat and summer maize were important grain crops in China, and winter wheat-summer maize continuous cropping was the main tillage method in north China. According to field experiment datas, Jensen models of winter wheat and summer maize were established respectively in this article. To pursue the biggest overall efficiency as object function, the partition of the finite water between wheat and maize were optimized, the optimal irrigation scheduling of continuous cropping of the two crops were confirmed in different hydrological years on different incoming water condition. This paper provided an efficient approach for promoting the reasonable use of agricultural water resources and enhancing water use efficiency in north China.

Keywords: Winter wheat, Summer maize, Continuous cropping, Irrigation mode.

1 Introduction

The double cropping of winter wheat with summer maize is the main irrigation pattern in North China plain. It is very important to full utilization of light resource and water saving. Many scholars researched the irrigation model of winter wheat and summer maize in the area of continuous double cropping [1-4], but most of them are also take winter wheat and summer maize divided and consider them respectively, which was unprofitable to water saving and increase the water utilize efficiency. Dynamic programming is a common method to make crop irrigation scheduling optimal, which was used to many researches [5-7]. Henan is a major grain-producing provinces of china, and the north area of Henan is the high quality area, Based on the meteorological many years data of Xinxiang in north Henan province, the water of different hydrological years was distribute the water of different hydrological years between crops and the growth stages optimal by using dynamic programming method, furthermore, the efficient irrigation model of north Henan province was put forward in this paper.

The research is very necessary for water-saving irrigation of the water resource utilization and reduction in the produce cost of winter wheat and summer maize, and the study of the efficient irrigation mode will supply the scientific decision basis and decision scheme for Henan province to choose the right water-saving irrigation technical and scientific management method for agriculture water resource, and promote the scientific popularize and the spread of water-saving irrigation agriculture, and also has the important application value of increasing the irrigation management level of crops.

2 Dynamic Programming Principle

Dynamic programming (DP) is a mathematical method to solve multistage decision process optimization which could break down into some interrelate stages with time sequence, we can obtain the whole optimal effect through making a decision in each stage, the decisions of all the processes is a decision series called multistage decision problem. According to its characteristic, it could be solved one by one through shifting into a series of single session inter-relative problems which are similar or the same. And according to the specific problem, we could also disperse the continuous time parameter of the multistage decision process into several time periods by actual requirement, and then make a decision for each period and thus make the whole process obtain the optimal. Therefore, the problem of water distribution in different growth stages of the crop could be solved by dynamic programming method.

The fundamental principle of the dynamic programming, namely the optimality principle [8] is no matter what the state and decision are in the past, the remaining decisions must form the optimal decision for the state made in the stage before as the optimal decision of the whole process. Usually we use the reverse recursion and sequential decision to resolve a determinacy dynamic programming problem. And if the index of the whole process with its sub-process is the format of continued product for the index of each stage that processes contain, then the fundamental equation for the reverse solution of the dynamic programming is as following:

$$f_i^*(s_i) = \underset{u_i \in D_i(s_i)}{\text{opt}} [Be_i(s_i, u_i) * f_{i+1}^*(s_{i+1})] \quad i = 1, 2, \dots, n \quad (1)$$

Where *opt* indicates the optimize, take *min* or *max* according to the need, $Be_i(s_i, u_i)$ is the index function of the i^{th} stage. $f_i^*(s_i)$, $f_{i+1}^*(s_{i+1})$ are the most optimized sub-policy of all sub-policies in the after sub-procedure that the original state is s_i , s_{i+1} respectively, $f_i^*(s_i)$ is the optimal strategy of the whole process. $u_i(s_i)$ is the decision variable that the current state is s_i of the i^{th} stage and is the function of state variable. $D_i(s_i)$ is the allowable decision set that set out from state s_i of the i^{th} stage. When the original state is definite, the decision of the process would be definite i^{th} stage, and the optimal value of the index function is also determined.

2.1 Distribution of the Finite Water for Growth Stages

The mathematical model of dynamic programming of water distribution as follows:

(1) Objective function

Use the *Jensen* model and make the max yield per unit area as objective:

$$F = \text{Max} \left(\frac{Y_a}{Y_m} \right) = \text{Max} \prod_{i=1}^n \left(\frac{ET_{ai}}{ET_m} \right)^{\lambda_i} \quad (2)$$

Where Y_a , Y_m and ET_{ai} have the same meanings as before. ET_{mi} and λ_i are the potential evapotranspiration(m³/acre) and water sensitive index of the i th stage respectively.

(2) Constraint condition

1) Decision constraint: $0 \leq d_i \leq Q_i$ ($i=1, 2, 3, 4, 5, 6$), d_i is the irrigating water quota, Q_i is the water which could be distributed in the i^{th} stage.

2) Finite water constraint: $\sum_{i=1}^n d_i = M$, M is the water which could be distribute in the whole growth period, namely irrigation quota.

3) Evapotraspiration constraint: $0 \leq ET_{ai} \leq ET_{mi}$, and when $ET_{mi} \leq W_i + P_{ei}$, $d_i=0$.

4) Soil water content constraint: $W_{wp} \leq W_i \leq W_f$, and when $W_f \leq W_i + P_{ei}$, $d_i=0$.

Where W_{wp} , W_i , W_f , P_{ei} are soil wilting moisture content, actual moisture content, field capacity and effective rainfall respectively, the units of them are all m^3/hm^2 . Soil water content could take for the constraint as $\theta_{wp} \leq \theta_i \leq \theta_f$ in specific calculate, and the θ_{wp} , θ_i , θ_f are the soil water content of W_{wp} , W_i , W_f respectively.

(3) Initial condition

1) θ_0 is the initial soil water content of crop, then when $i=1$, the initial available soil water is:

$$W_i = 1000H\gamma(\theta_0 - \theta_{wp}) / \gamma_{\text{水}} \tag{3}$$

Where H is the depth of designed moisting layer of soil [m], γ is the dry density of soil[g/cm³], θ_0 is the initial soil water content, calculates as the percentage of dry soil weight, $\gamma_{\text{水}}$ is the unit weight of water[g/cm³].

2) The 1st time-period initial water which could be distributed, namely irrigation quota: $d_1=M$.

(4) State transition equation

1) Water distribution equation: $Q_{i+1} = Q_i - d_i$, where Q_i is the i th time-period initial water which could be distributed of the i thstage [m³].

2) Soil water balance equation: $W_{i+1} = W_i + P_{ei} + d_i - ET_{ai}$, consider the irrigative water and effective rainfall only, but not the deep leakage and the increment of ground water.

(5) Recurrence equation

Because of the two state variable and two decision variable, Successive approximation approach(DPSA) could be used to reduce the dimensions and the calculate.

When use the approach to resolve two dimension dynamic programming, the recurrence equation are the disperse two one-dimensional recurrence equations of the state variable Q_i and W_i , respectively, from the formula (1) we can get the fundamental equation of reverse solution as follows:

1) For the state Q_i :

$$f_i^*(Q_i) = \underset{d_i \in Q_i}{opt} [Be_i(Q_i, d_i) * f_{i+1}^*(Q_{i+1})] \quad i = 1, 2, \dots, n \quad (4)$$

Where $Be_i(Q_i, d_i) = (ET_{ai} / ET_{mi})^{\lambda_i}$ is the current stage benefit in state Q_i when the decision is d_i . $f_{i+1}^*(Q_{i+1})$ is the optimal value from stage $i+1$ to the last, in the last stage, $f_i^*(Q_i) = (\frac{ET_{ai}}{ET_{mi}})^{\lambda_i}$.

2) For the state W_i :

$$f_i^*(W_i) = \underset{ET_{ai} \in W_i}{opt} [Be_i(W_i, ET_{ai}) * f_{i+1}^*(W_{i+1})] \quad i = 1, 2, \dots, n \quad (5)$$

Where $Be_i(W_i, ET_{ai}) = (ET_{ai} / ET_{mi})^{\lambda_i}$ is the current stage benefit in state W_i when the decision is ET_{ai} . $f_{i+1}^*(W_{i+1})$ is the optimal value from the $(i+1)^{th}$ stage to the last, in the last stage, $f_i^*(W_i) = (\frac{ET_{ai}}{ET_{mi}})^{\lambda_i}$.

Using DPSA to resolve two dimension dynamic programming, we take a state variable as fixed firstly, then inverted sequence optimization and Sequential Solution aiming at another status variable, and then rotationally fixing until it reaches the required date.

The step of the DPSA method to resolve this dynamic programming is:

1) Fixing the state variable W_i as the virtual path firstly, make $W^{(0)} = \{W_1^{(0)}, W_2^{(0)} \dots W_n^{(0)}\}$ ($W_i^{(0)}$, $i = 1, 2, \dots, n-1$, stands for the available water in soil planned moisture layer in the initial of each stage respectively. $W_n^{(0)}$ is the soil moisture content at the end of the period), the first state variable Q_i and decision variable d_i are dispersed to several levels as the step length $\Delta = 600m^3/hm^2$, this is one-dimensional dynamic programming, the convention dynamic method as equation (4) could be used to calculate the optimal result. Given the result is

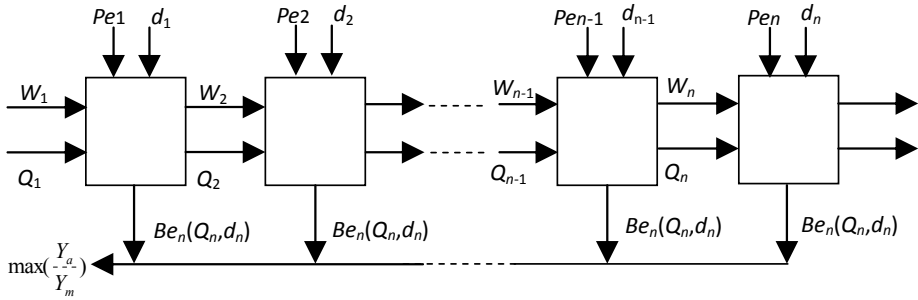

Fig. 1. Relationship between state change and decision of system

$d^{(0)} = \{d_1^{(0)}, d_2^{(0)} \dots d_n^{(0)}\}$ which is the optimal irrigation water of each stage, and $W^{(0)} = \{W_1^{(0)}, W_2^{(0)} \dots W_n^{(0)}\}$ which is the total irrigation that could supply in the initial of each stage.

2) Fixing the $Q^{(0)}$ and $d^{(0)}$, the optimal value of the soil available water W_i and the actual evapotraspiration ET_{ai} of each growth period are seeked in the initial condition. Second state variable is dispersed to several levels from wilting moisture content to field capacity as the step length $\Delta = 1\%$, then get the optimal result $\{W_i^*\}$ by equation (5).

3) Compared the virtual track of the soil moisture content in the first step with the optimal result of the soil moisture content in the second step, if the virtual track of the first step and the optimal result of the second step does not match with the limiting condition of the prediction, then the optimize processes above until the two state variables have the same objective function value and irrigation decision series values which is the optimal result that we need. The relationship between state change and decision of the system shows in figure 1, and the program of reverse algorithm of dynamic planning shows as figure 2.

In Fig. 2, s_{-i} , s_{+i} stand for the higher and lower limit value of state variable s_i respectively.

And in the actual calculation process, s_i could be replaced to state variable Q_i and W_i respectively.

The left-component of the block diagram is the optimal function value and stage decision value searched reversed in stage, and the right-component of the block diagram is the optimal objective function value $f_1^*(Q_1)$ which is $Max(Y_a / Y_m)$ and optimal decision value series d_i^* which is the optimal irrigation quota of each stage that decided orderly of the whole process. Pe stand for the rainfall of different typical years in Fig. 3.

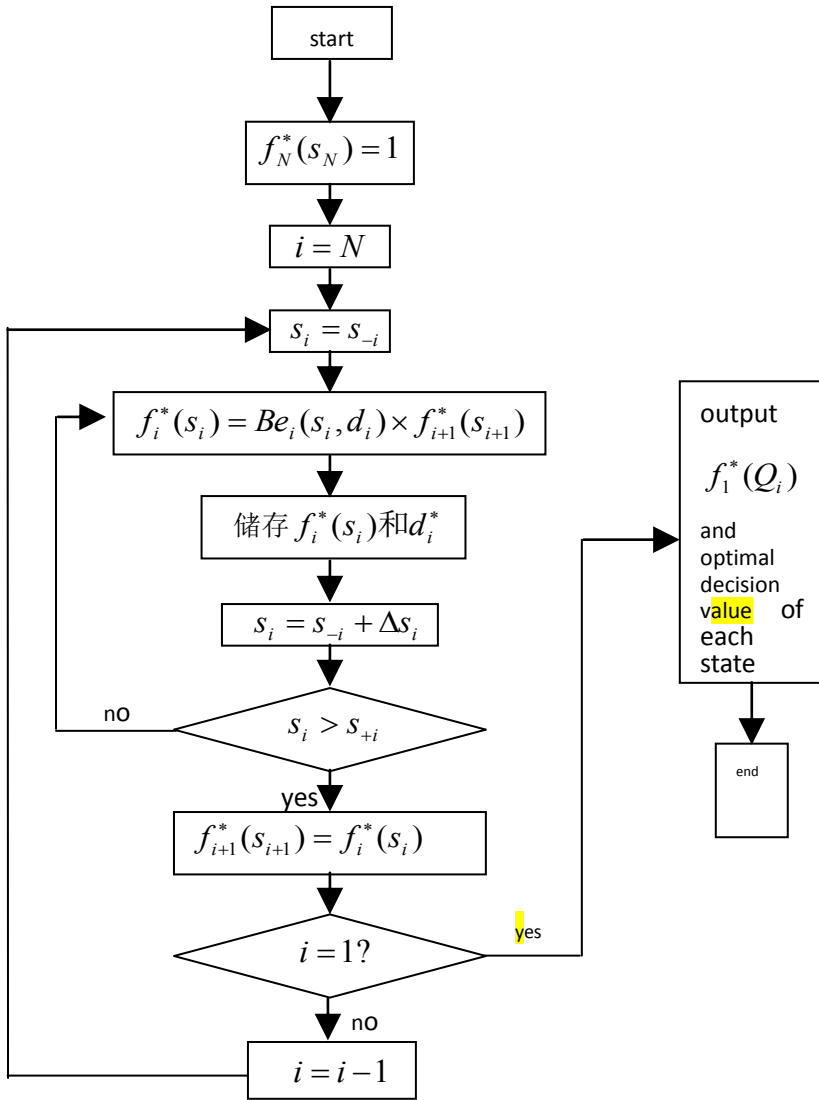

Fig. 2. Program of reverse algorithm of dynamic planning

2.2 Partition of the Finite Water between Crops

Based on the optimal distribution of finite water between different crops growth stage, using the DP method, the limited whole irrigation water (Q_c) is distribution between different crops. The mathematical model as follow:

1) Stage variable: the time factor is introduced and each crop is regard as a time stage, then $i=1, 2 \dots n$, stands for the crop that should consider respectively.

2) State variable: the total water Q_{ci} which could be distributed to each crop in the initial of each stage.

3) Decision variable and state transition equation: decision variable is the net irrigation water d_{ci} that is distributed to each crops, state transition equation is $Q_{ci+1} = Q_{ci} - d_{ci}$.

4) Objective function: take the largest total benefit of each crop as the object,

$$B_c^* = \max \left\{ \sum_{i=1}^n f(Q_{ci}) \times A_i \times Y_{mi} \times P_{mi} \right\} \quad (6)$$

Where $f(Q_{ci})$ is the benefit when distribute water Q_{ci} to crop i , A_i [hectare], Y_{mi} [kg/hm²] and P_i [yuan/kg] are the plant area, potential yield and unit price respectively.

5) Initial condition: $Q_{ci} = Q_c$, which stands for the distributed water of the initial of the first stage equals to the finite total irrigation water.

6) Constraint condition: $0 \leq d_{ci} \leq Q_{ci} \leq Q_c, \sum_{i=1}^n d_{ci} \leq Q_c, Q_c$ is the total water of the irrigated area which could be utilized.

7) Recurrence equation: the reverse recursion and sequential decision is adopted, the recurrence equation as follow:

$$B_{ei}^*(Q_{ci}) = \max_{d_{ci}} \left\{ f(Q_{ci}) \times A_i \times Y_{mi} \times P_i + B_{ei}^*(Q_{ci+1}) \right\} \quad i=1, 2 \dots n \quad (7)$$

Where $B_{ei}^*(Q_{ci}), B_{ei+1}^*(Q_{ci+1})$ are the optimal benefit of the i^{th} and $(i+1)^{th}$ stage respectively, $f(Q_{ci})$ is the index function of the i^{th} stage, and the other symbols have the same meanings as before.

3 Analysis Results

3.1 Relevant Parameters

3.1.1 Rainfall of Typical Years

Based on the diurnal rainfall data from 1984 to 2003, the sum of the rainfall of each month was worked out. The experience cumulative frequency curve could be drew out according to the data as shown in figure 3, and also could get out the rainfall in different typical hydrological year (25%, 50%, 75%, 95%) as shown in table 1.

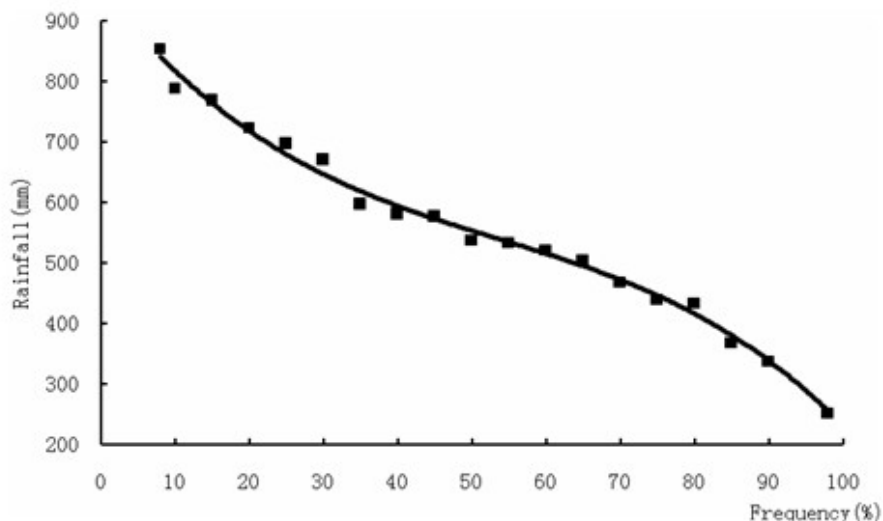

Fig. 3. Experiential cumulative frequency curve

Table 1. Rainfall of different typical hydrological years (mm)

25%	50%	75%	95%
700	560	450	320

Table 2. Monthly average rainfall of different hydrological years (mm)

Hydrological year	Jan.	Feb.	Mar.	Apr.	May	June	July	Aug.	Sep.	Oct.	Nov.	Dec.	Total rainfall
25%	5	6	20	24	66	70	243	209	86	46	12	5	792
50%	6	12	22	38	67	83	158	112	39	43	31	6	617
75%	10	4	13	13	17	67	150	127	46	38	9	11	504
95%	6	5	29	14	80	57	55	57	43	28	7	7	386

According to the water of different hydrological year, the four year rainfall which stand for the four hydrological years were elected as objects of study. The related datas as shown in table 2. Furthermore, according to the start and end date of different growth stage, the rainfall in the growth stage of winter wheat and summer maize could be determined as shown in table 3 and table 4. Thus provides the basis of rainfall data for partition of the finite water between each growth stage of crops.

Table 3. Rainfall of winter wheat each growing season of different hydrological years

Crop	Hydrological year	Seeding stage	Winterovering period	Reviving stage	Jointing stage	Booting stage	Seed filling stage
Winter wheat	25%	11	13	10	26	16	58
	50%	25	20	11	36	21	59
	75%	13	18	7	15	6	15
	95%	9	13	15	24	15	70

Table 4. Rainfall of summer maize each growing season of different hydrological years (mm)

Crop	Hydrological year	Seeding stage	Jointing stage	Earring stage	Seed filling stage
Summer maize	25%	128	197	105	176
	50%	108	124	56	89
	75%	95	121	64	102
	95%	56	46	29	64

3.1.2 Relevant Parameters of Crops

The relevant parameters of winter wheat and summer maize are showed in table 5.

Table 5. Relative parameters of crops

Crops	Potential yield(kg/hm ²)	Plant area(hm ²)	Unit price-(yuan/kg)
Winter wheat	6327.9	10	1.46
Summer maize	9465.9	10	1.16

3.2 Optimization Results

The optimal irrigation regime of different hydrological years and water supply conditions for winter wheat and summer maize by using dynamic programming method is shown in Table 6 and 7. According to many times irrigation experiment results, the step length of decision variable d_i was confirmed, namely 600m³/hm² which was easy to carry out and propitious for increasing degree of homogeneity of irrigation. Table 8 is the optimal irrigation regime of winter wheat and summer maize from Oct. 2003 to Dec. 2004, the rainfall of these two growth stages are both about 716mm which was tantamount to the hydrological year of 25%. Three times were irrigated in the growth age of winter wheat and no time of summer maize, it can be seen that the result is in accord with table 6 and 7.

Table 6. Optimal irrigation regime of different hydrological years for winter wheat

Hydrological year	Available irrigation water (m^3/hm^2)	Stage and irrigation age (m^3/hm^2)						Y/Y_m
		Seeding	Winteroverin	Revivin	Jointin	Booting	Seed filling	
		~ Winter overing	~ Reviving	~ Jointing	~ Bootin g	~ Seed filling	~ maturation	
25%	600	0	0	600	0	0	0	0.8217
	1200	600	0	0	600	0	0	0.9311
	1800	600	0	0	600	0	600	0.9934
50%	600	0	0	600	0	0	0	0.7489
	1200	600	0	0	600	0	0	0.8476
	1800	600	0	0	600	0	600	0.9207
	2400	600	0	600	600	0	600	0.9625
75%	600	0	0	600	0	0	0	0.6754
	1200	600	0	0	600	0	0	0.7805
	1800	600	0	600	0	600	0	0.8653
	2400	600	0	600	600	0	600	0.9402
95%	600	0	0	600	0	0	0	0.6537
	1200	0	0	600	0	600	0	0.7642
	1800	600	0	600	0	600	0	0.8487
	2400	600	0	600	600	0	600	0.9201

Table 7. Optimal irrigation regime of different hydrological years for summer maize

Hydrological year	Available irrigation water (m^3/hm^2)	Stage and irrigation age (m^3/hm^2)				Y / Y_m
		Seeding	Jointing	Earring	Seed filling	
		~ Jointing	~ Earring	~ Seed filling	~ maturation	
25%	0	0	0	0	0	0.9913
	0	0	0	0	0	0.7342
	600	0	600	0	0	0.9078
75%	600	0	600	0	0	0.7524
	1200	600	0	600	0	0.8951
	1800	600	600	600		0.9652
95%	600	0	600	0	0	0.5435
	1200	600	0	600	0	0.7363
	1800	600	0	600	600	0.8834
	2400	600	600	600	600	0.9315

Table 8. Irrigation regime of double cropping of winter wheat with summer maize (2003-2004)

Irrigation time	Nov. 5th	Mar. 10th	May 10th
Irrigation water(m^3/hm^2)	600	600	600

The optimal distribution results of different finite water for winter wheat and summer maize in each hydrological year are showed in table 9.

Table 9. Partition of water for crops of different hydrological years

hydrological year	Total water (m^3)	Water that optimal distribute to crops (m^3)		Total benefit (ten thousand yuan)
		Winter wheat	Summer maize	
25%	12000	12000	0	13.87
	24000	24000	0	22.36
	36000	36000	0	23.91
50%	12000	12000	0	14.71
	24000	20000	4000	18.35
	36000	28000	8000	19.8
75%	12000	3000	9000	10.56
	24000	24000	0	15.81
	36000	33000	3000	18.95
95%	12000	0	12000	7.7
	24000	16000	8000	11.92
	36000	21000	15000	16.39

4 Summary

(1) Based on the diurnal rainfall data from 1984 to 2003, the experiential cumulative frequency curve was protracted, the precipitations of the four typical hydrological years were confirmed, the precipitation of each growing stage during the representative hydrology years were calculated.

(2) The partition of the finite water between the growth stages and the crops were optimized, the irrigation scheduling of wheat and maize were confirmed, with the dynamic programming method and the model of yield and water consumption of each growing stage.

(3) The partition of the finite water between the growth stages and the crops were optimized, the irrigation scheduling of wheat and maize were confirmed, with the dynamic programming method and the model of yield and water consumption of each growing stage.

References

1. Peng, Z., Sun, S., Sheng, J.: Research on Optimal Irrigation Scheduling of Winter Wheat with Water-saving and High Efficiency. *Journal of Irrigation and Drainage* 22(5), 77–80 (2003)
2. Lu, Z., Meng, C., Wang, X.: Study on Winter Wheat Optimum Irrigation Schedule Based on the Genetic Algorithm. *Yellow River* 31(11), 76–78 (2009)
3. Niu, Y.: Research on winter wheat's optimum irrigation schedule in jinzhong region. *Shanxi Hydrotechnics* 2 (2007)
4. Wang, Z., Chao, L., Tiangu, X., et al.: Determination of Economical Irrigation Schedules for Maize Growth in Dalate Banner. *Journal of Arid Land Resources and Environment* 19(7), 157–161 (2005)
5. Liu, k., Zheng, X.-r., Ren, Z., et al.: Research on Crop-water Production Function and Irrigation Procedure. *Journal of Shihezi University* 22(5), 383–385 (2004)
6. Liu, G., Yang, J., Jiang, Y., et al.: Optimized rice irrigation schedule based on controlling irrigation theory. *Transactions of the CSAE* 21(5), 29–33 (2005)
7. Sun, S., Wang, X., Wang, Y.: Study on optimization of limited irrigation system based on crop water production function. *Water Resources and Hydropower Engineering* 36(10), 105–108 (2005)
8. Qian, S.: *Operational Research*, pp. 78–79. Tsinghua University Press, Beijing (1990)