

Development of a Semi-controller for a Variable Rate Fertilizer Applicator*

Jianbin Ji¹, Xiu Wang^{1,*}, Yijin Mao², Liping Chen¹, and Lingyan Hu³

¹ National Engineering Research Center for Information Technology in Agriculture,
Beijing 100097, China,
Voice: +00-86-51503696
wangx@nercita.org.cn

² China Agricultural University, Beijing 100083, China

³ TaiYuan University of Technology ShanXi 030024, China

Abstract. In this paper, aiming at the current development of domestic agricultural production, introduced a variable fertilizer controller which suits for a domestic food-producing areas to promote output. The variable rate fertilization controller combined with the current Chinese made fertilizer equipment; mechanism of metering system for the applicator uses a flute wheel. The amount of fertilizer is determined by the rotation speed of flute wheel. The use of the control system can be inconsistent in soil fertility, pre-division of plots with different fertilizer way through the process of moving the driver automatically adjusts the amount of fertilizer direction buttons to precision variable fertilization. Papers on the electronic structure of the controller and software design in detail. In addition, we have examined the performance of this new product in the field by using different fertilizer and requirement. The results reveal that semi-automatic controller work well by controlling the quantity of fertilizer precisely. Specifically, coefficient of variation of fertilizing is controlled to be less than 5%. That means this new type semi-automatic controller worth developing in further.

Keywords: speed adjustment, speed signal collection, real-time control, variable rate fertilizer.

1 Introduction

Recently, farmers around the world generally use chemical fertilizers as the main means of increasing food production, farmers in most areas are evenly spread the fertilizer in the surface, and then make the appropriate agronomic operations. To take such operating procedures, soil nutrients in the high area and in the low area still use the same amount of fertilizers resulted in a high position in the nutrient over-use, and the location of low-nutrient may occur fertilizer shortage. In the over-use area, part of chemical

* Supported by National High-tech R&D Program of China (863 Program) (Grant No. 2006AA10A308); Supported by Beijing Rural Affair Committee (Grant No. 20070110).

* Corresponding author.

fertilizers in the soil break down or be absorbed, some of others by leaching in the soil, these fertilizer undergo eluviations absorbed by groundwater easily to pollute the underground water resources, and affect people's health. Thus, as the voice of sustainable development of agricultural production increasing, the environment pollution caused by chemical fertilizers be concerned more and more in the countries, most developed countries have established relevant laws to restrict the use of chemical fertilizers.

With popularization of the technology of the global positioning system (GPS), when the tractor carries on the field work, the tractor can obtain the real-time work position accurately under the GPS system help, Therefore, manage the soil by fixed position become a riper technology. But this technology is comparatively complicated, the short term, the nationwide promotion of access to a large area will be subject to funding, staff skills and the specific restrictions related to the environment. Therefore in order to promote the technology quickly, based on soil nutrient status of the field, we can divide the same block into different application management unit, through setting up different operating signs in each unit, using semi-automatic variable rate fertilization realize manual control of variable rate fertilization, drivers do not need to leave the driver's seat, by changing the button on the controller to achieve the purpose of accurate variable rate fertilization. Semi-automatic controller of variable rate fertilizer applicator can receive the speed of tractors and automatic adjust the fertilizer volume to achieve accurate variable rate fertilization. This paper aimed at the current equipment characteristics of agriculture of China; carried out semi-automatic variable fertilization technology research, the developed semi-automatic controller of variable rate fertilizer applicator can automatic calculate the fertilizer volume according to tractors speed. Drivers can also facilitate change the fertilizer volume in fertilization; overcome the traditional deficiencies of parking change fertilizer volume.

2 Controller Structure

Control functions by the two co-ordinations 51 single-chip realization, system architecture as shown in Figure 1. System has five major components: PWM pulse signal output module, operation module, LCD module, power supply module and drive module.

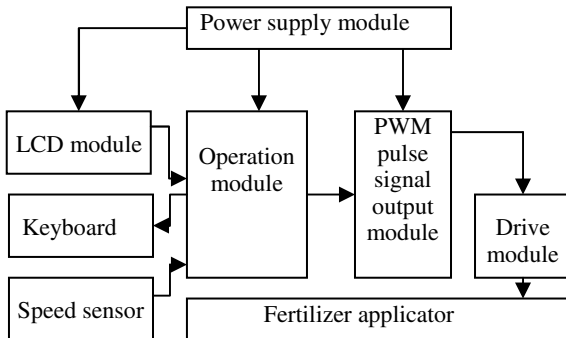

Fig. 1. The structure of semi-automatic variable rate

2.1 PWM Pulse Signal Output Module

PWM control chip generated and output PWM pulse signal, the PWM control chip adopted AT89S52 single-chip. This module is simple in design, the main reason is: if these are too many functions in design, chip need much time to run these functions, this may impact the output PWM signal, and it will affect the accuracy of the fertilization. The module structure is in Figure 2.

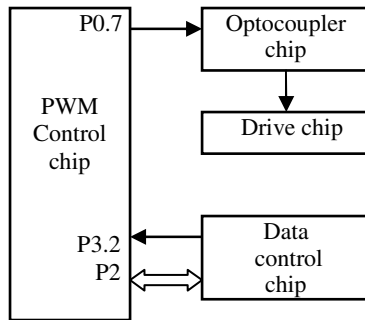

Fig. 2. PWM output module

In this module, as output PWM pulse signal pin, the P0.7 pin of PWM controlling chip, which outputs signal to amplifier drive module isolated by optocoupler chip, the output drives hydraulic Flow Valve. P2 interface of PWM controlling chip is connected with P2 interface of data controlling module, PWM controlling chip will change the output pulse width according to duty cycle computed and sent by data controlling chip. P3.2 pin is external interrupt pin, which can enable PWM controlling chip to respond immediately to adjust PWM pulse width in time, when data controlling chip computes duty circle needing varying immediately.

2.2 Operation Module

Operation module mainly operates data and harmonizes parts function, including input and control of keyboard, LCD module, tractor rate collection, and output of PWM duty circle signal and so on. Fig3 is module connecting block diagram. P0 interface of data controlling chip is connected with 4*4 keyboards, for the convenience of controlling data during the process of fertilization, one column keys are connected with interrupt interface P3.3 pin, when one is pressed, it will touch off interrupt of data controlling chip. P1 interface is used as data output interface of LCD module, which input the needing data to LCD module. The pins of P2.1 P2.2, P2.3 are multiplexing pins with different functions controlled by code; here they are used as LCD controlling pins. P3.2 pin is external interrupt pin, which is used for signal input pin to collect pulse signal of speed sensor. Data controlling chip adopts timer T1 to time the system.

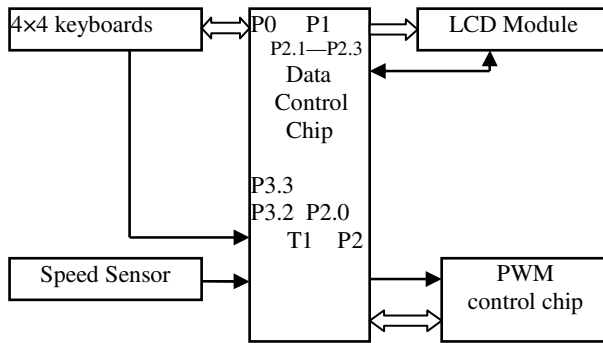

Fig. 3. Operation module

2.3 LCD Module

LCD module is convenient for human-computer interaction; it could display data and menu. The system designed four menus: pre-set fertilizer volume input, per-axis fertilizer volume set, tractor speed calibration, and fertilization. When pre-set fertilizer volume input menu, the value can be set manually according to the anticipant fertilizer quantity, per-axis fertilizer volume set menu adjust to different fertilizer mechanism and different kinds of fertilizer, its set value is the number of how many grams of fertilizer output when the axis makes one revolution, the system can not test fertilizer output when the axis makes one revolution automatically for the sake of decreasing cost. Tractor speed calibration menu is to overcome skid factor, tractor speed calibration menu responds tractor rate at different task conditions correctly to fertilize exactly. field operation, first measure one hundred meters, press enter key on controller when tractor starts at starting point, then press it again when the tractor reaches end point, the system can adjust automatically and achieve accurate speed value. Fertilization menu watches fertilization state, here preset value, fertilizer output and tractor speed etc. can be seen.

2.4 Software Design Process

The controller software design is based on the fertilization process, figure 4 flow chart for software design. According to the current international fertilizer applicator, the axis of fertilizer volume parameter is set to check volume. Therefore, for different varieties of fertilizer, farmers must be carried out the fertilizer volume in each row of axis before fertilization, and the checked fertilizer volume is only suitable for such fertilizer, if change fertilizer, check it again. In addition, farmers need to pre-set the fertilizer volume before fertilization and check the speed of tractor. This concept, software designed menu displayed on the LCD screen, are as follows: pre-set fertilizer volume, per-axis fertilizer volume, tractor speed and fertilization.

3 Experiment and Testing

In order to achieve the purpose of accurate fertilization must pre-measure the per-axis fertilizer volume, as well as the relationship between the PWM pulse duty cycle, the revolution speed of axis and the tractor speed.

Preparatory work: connect the controller PWM output line to the input port of oil flow control valve, connect the oil pipeline of oil flow control valve to the input and output ports of tractor, the power line of controller connect to the battery, adding fertilizer into fertilizer hopper, start the tractor. Fertilization experiments using a total of 24 fertilizer exhaust port, select 24 plastic 10L capacity box marked No. 1-24 for each fertilizer exhaust port select fertilizer, to facilitate weigh the volume of fertilizer. Weighing use the electronic scales. Fertilizer-axis speed measurement using the contact tachometer.

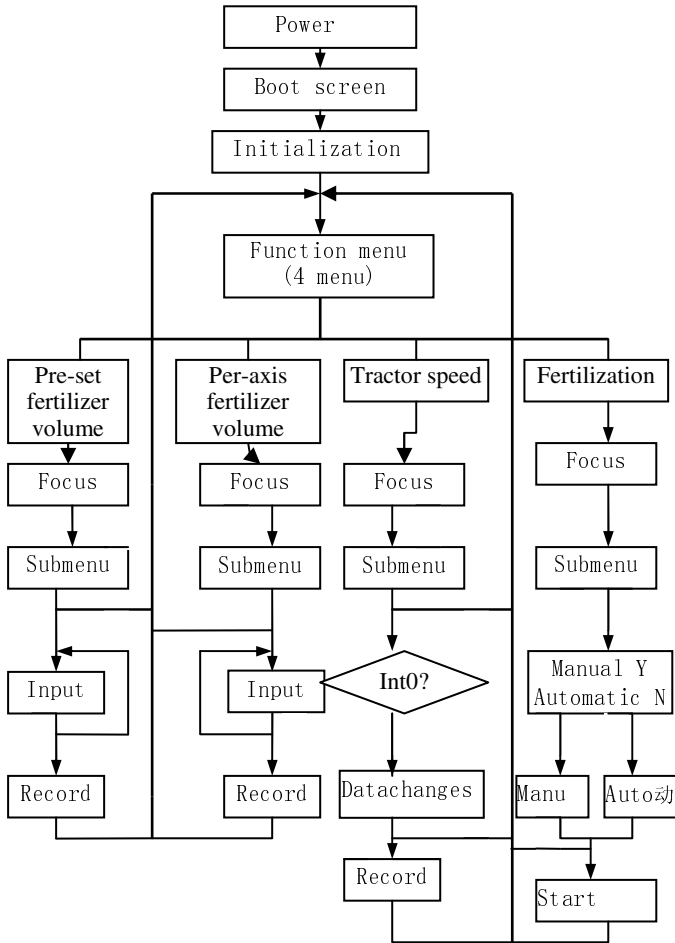

Fig. 4. Software design chart

3.1 The Per-axis Fertilizer Volume Measurement

Methods: The controller use the manual mode, put the PWM pulse width to a random value, at the same time record the number of fertilizer-axis turning circle, stop and

weigh the total output fertilizer and divided by the number of turning circle. Change the PWM pulse width, re-measured and calculated. The average results of several measurements are the per-axis fertilizer volume.

3.2 The Relationship between the PWM Output Signal Width and the Revolution Speed of Axis

The controller of variable rate fertilizer applicator is manual mode, set PWM pulse width to a smaller value, measuring and recording the revolution speed of axis. Increase PWM pulse width, measure again. Repeatedly measured and calculated come to the relationship between the revolution speed of axis and the PWM signal pulse width, shown in Figure 5.

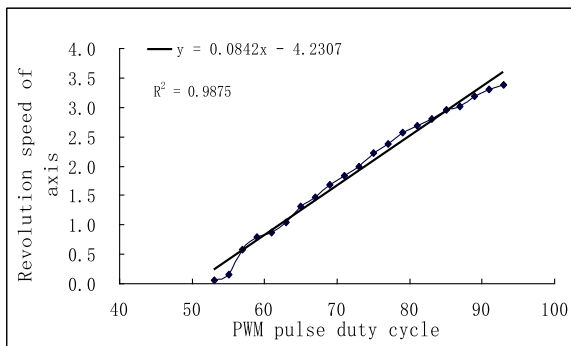

Fig. 5. The relation of PWM pulse width and axes rotates

When the width of the PWM output signal increases (the PWM duty cycle that is upgrading), revolution speed of axis also enhance, and is obviously linear increase. According to experiments, the linear relationship is $y = 0.0842x - 4.2307$, y is the revolution speed of axis and x is the width of the PWM.

3.3 The Relationship between Pre-set Fertilizer Volume, PWM Output Signal Width and Tractor Speed

When the pre-set fertilizer volume is set, the relation between PWM pulse signal width and tractor speed is linear, if the speed go up, the rotate speed will go up, namely PWM pulse width will increase, and vice versa. The rotation axis with twenty teeth on fixed gear drives fertilizer axis with 26 teeth on gear through chain. The fertilizer output port is total 3.6 meter, formula 1 is deduced through integrating all parameters, put axis rotation speed and PWM pulse signal width into formula 1, relation between PWM pulse width and tractor speed could be achieved.

Use code to build the relation among these varies, writes the code in chips, Adjusting fertilizer automatically according to tractor rate is implemented.

4 Field Trials and Testing

At present, fertilization mainly use granular fertilizer, Therefore the trial use urea. Test Method for fertilizer in the fertilizer hopper width of 3.6 meters and the fertilizer exhaust port width of 18mm, driving a tractor traveling 100 meters, test the output fertilizer volume. such as Table 1. In the actual measurement, the permissible error in the 5% error range, so it meets the purpose of variable rate fertilization and its standards.

Table 1. Fact test

NO.	Pre-set fertilizer volume	Actual fertilizer volume	Actual error	Variation coefficient
1	14.4kg	15.19kg	0.79kg	0.05
2	10.8kg	11.17kg	0.37kg	0.03
3	7.2kg	7.51kg	0.31kg	0.04
4	50kg	54.24kg	4.24kg	0.80
5	80kg	83.52kg	3.52kg	0.03
6	100kg	102.86kg	2.86kg	0.02
7	150kg	154.53kg	4.53kg	0.03
8	200kg	196.20kg	3.80kg	0.03
9	250kg	245.74kg	3.26kg	0.02
10	300kg	297.56kg	2.44kg	0.01

As can be seen through Table 1, experimental error shows irregular changes. The main reason is that the errors are due to the physical properties of devices and operating factors, and even generate an error. Therefore, the operator can adjust the use of agricultural machinery and methods of operation to achieve the purpose of smallest error in fertilization.

5 Conclusion

The controller designs simpler, can not connect to GPS / GIS systems, and did not adding the feedback control functions, which greatly reduces the design cost. In addition, the controller can collect the speed signal of tractor in real-time, realize the purposes of the fertilizer automatic adjustment according to the tractor speed.

The status of China's agricultural production is that Chinese farmers have less agricultural machinery and equipments, but the domestic product 37.8KW tractor which can conjunction with fertilizer application system for agricultural production is in more.

Most of the variable rate fertilization system which developed by the current domestic or international are complicated to use and control, and the prices are expensive, difficult to purchase for farmers. The controller described in papers has a simple structure, easy to operate, and at a great price, suitable for the vast rural areas to promote. Controller of the field-fertilization experiment can achieve described function; greatly enhance the efficiency of fertilization. In this paper, the controller of variable rate fertilizer applicator is based on traditional variable rate fertilizer applicator and innovation, operation more convenient, more obvious effect of fertilization.

Acknowledgements

Supported by National High-Tech R&D Program of China (863 Program)(Grant No. 2006AA10A308); Supported by Beijing Rural Affair Committee (Grant No. 20070110).

References

- Sawyer, J.E.: Concepts of variable rate technology with considerations for fertilizer application. *Prod. Agric.* 7, 195–206 (1994)
- Han, S.F.: Nitrogen sensing and site-specific application technology. In: *Information Technology of Agriculture, Proc. of the International Conference on Agricultural and Technology*, Beijing, China, June 2001, pp. 324–330 (2001)
- Raun, W.R.: Improving Nitrogen Use Efficiency in Cereal Grain Production with Optical Sensing and Variable Rate Application. *American Society of Agronomy Journal* 94, 815–820 (2002)
- Sawyer, J.E.: Concepts of variable rate technology with considerations for fertilizer application. *Prod. Agric.* 7, 195–206 (1994)
- Le Maitre, R.W.: *Numerical Petrology. Statistical Interpretation of Geochemical Data*, 210 (1982)