

BICAR—Urban Light Electric Vehicle



Hans-Jörg Dennig , Adrian Burri, and Philipp Ganz

Abstract This paper describes the technical features of the light electric vehicle (L2e-category) named BICAR. This specially designed vehicle is an all-in-one emissions-free micro-mobility solution providing a cost-effective and sustainable mobility system while supporting the transition towards a low carbon society (smart and sustainable city concept). The BICAR represents part of a multimodal system, complementing public transport with comfort and safety, relieving inner-city congestion and solving the “first and last mile” issue. The BICAR is the lightest and smallest three-wheel vehicle with weather protection. Due to the space-saving design, six to nine BICARS will fit into a single standard parking space. Safety is increased by an elevated driving position and a tilting mechanism when cornering. The BICAR achieves a range of 40–60 km depending on the battery package configuration in urban transport at a speed of 45 km/h. It features a luggage storage place and exchangeable, rechargeable batteries. The BICAR can be driven without a helmet thanks to the safety belt system, which is engineered for street approved tests. The BICAR has an integrated telematic box connected to the vehicle electronics and communicating with the dedicated mobile application, through which the BICAR can be geo-localised, reserved, locked/unlocked and remotely maintained.

Keywords L2e · Shared mobility · Light electric vehicle (LEV) · Cradle to cradle · Solar cell · Urban transport

H.-J. Dennig (✉) · A. Burri · P. Ganz
ZPP Centre for Product and Process Development, ZHAW Zurich
University of Applied Sciences, Winterthur, Switzerland
e-mail: hans-joerg.dennig@zhaw.ch

© The Author(s) 2021
A. Ewert et al. (eds.), *Small Electric Vehicles*,
https://doi.org/10.1007/978-3-030-65843-4_12

1 Introduction

In 2014, a research team led by Adrian Burri and Hans-Jörg Dennig at the Zurich University of Applied Sciences (ZHAW) initiated work on a new vision for an innovative, individual and eco-friendly mobility solution with maximum safety standards and comfort [1]. Two years of research and development activities led to the creation of a pioneering product for urban mobility, the BICAR. After extensive positive feedback from mobility experts, visitors at fairs and end customers, the ZHAW spin-off company “Share Your BICAR AG” was founded in 2016 with the goal of finalising and commercialising the BICAR. The BICAR is designed for individual users to cover short and medium distances in urban areas. Target customers are mobility sharing providers, business fleet providers and private individuals.

The latest version (see Fig. 1) was presented at the Geneva International Motor Show 2019, generating immense international interest from city authorities, firms, private customers and the media. This article describes the technical features and their background of the current model.



Fig. 1 BICAR—Main features: 1. weather protection incl. wiper system; 2. solar powered; 3. safety belt system; 4. three-wheel-tilting chassis; 5. needs only 1.2 m² parking space; 6. robust tubular frame

2 Main Features

The BICAR is the lightest (≈ 120 kg) and smallest (1.2 m² footprint), electrically powered (in-wheel motor) three-wheel vehicle on the market (see Table 1). The BICAR design has been focussed from the beginning on space-efficiency (ease of parking, agility in urban environments) and lightweight construction (maximum energy efficiency). Six to nine BICARs can be parked in a conventional car parking space, relieving road parking space. Therefore, car sharing providers can offer more sharing vehicles, and customers will appreciate that parking space for the BICAR is more easily available than for conventional vehicles. It is sustainable and emissions-free, Cradle to Cradle® certified and energy autonomous with integrated solar cells and, optionally, a backup battery-swap system. The BICAR is an L2e-category vehicle, which can be driven with an AM (EU) driving licence for two- or three-wheel vehicles with a maximum design speed of not more than 45 km per hour. Hence, no car driving licence is needed.

Available in-wheel motors on the market are either too weak (max. 1 kW) or too powerful conceived for heavier vehicles, which makes them too heavy, expensive and inefficient for a lightweight vehicle like the BICAR. In collaboration with an in-wheel motor supplier, an in-wheel motor for vehicles in the weight category <200 kg was developed.

The BICAR is designed for urban use and therefore has a maximum speed of 45 km per hour, which enables construction to be much lighter and thus energy-saving than for micro-cars. The BICAR's energy consumption is even lower than that of a standard motorcycle¹ and up to 95% less than that of a conventional

Table 1 Overview of selected light electric vehicles (LEVs) with weather protection

Model	BICAR BICAR	Renault Twizy	Toyota iRoad	Toyota COMS	Tremola AD Tremola	Torro Velocipede	Kyburz PLUS
Category	L2e	L7e	L2e	L7e	L6e	ND	L6e
Wheels	3	4	3	4	3	3	4
Speed (km/h)	45	80	45	60	80	80	30
Weight (kg)	120	550	300	408	270	245	250
Footprint (m ²)	1.2	2.87	1.93	2.4	1.6	1.7	ND ^a
Passengers	1	2	2	1	2	2	1

^aND = Not defined

¹The energy consumption of light electric vehicles in urban use depends on their weight. The rolling resistances are similar for all vehicles. The aerodynamic resistance plays a minor role in urban traffic.

car [1]. According to the New European Driving Cycle, the BICAR uses 48 Wh/km. The BICAR achieves a range of 40–60 km depending on the battery configuration in urban transport.

A semi-closed cabin construction was designed to protect the driver from wind, rain or snow, while providing enough air circulation to avoid the need for air-conditioning and featuring medium-sized luggage capacity. A three-point safety belt/seat construction connected to the vehicle frame ensures safety for the driver without the need for a helmet.

An integrated telematic box allows communication between the user's phone and the on-board electronics, providing information about vehicle status and access to telemetry data collected through the backend software. These are: battery status (charging and discharging cycles incl. recuperation, battery and environmental temperature, running hours), real-time motor-management-data (ampere and voltage of the motor consumption, vibration, acceleration levels) and usage (geo-localization, driving data, user data). The data is remotely accessible, and maintenance service can be planned before any failure/breakdown occurs (predictive maintenance).

Due to the reduction exclusively to the main functions, design elements in the interior and exterior and thus additional components were avoided. If a vehicle for individual traffic is developed exclusively for urban use, the chassis and structure can be designed simpler. All this leads to significantly lower production costs than for other small three- or four-wheeled vehicles. Maintenance costs are also kept low due to the robust construction and as the telematic box provides predictive maintenance.

3 Cradle to Cradle Production

For the BICAR, a sustainable material- and production-concept according to the Cradle to Cradle principle was developed. Cradle to Cradle® (C2C) design means that all the resources used for the product are reusable in an infinite recycling process. Further, no environmentally toxic materials, liquids or chemicals are used. With the current state of available certified materials, it is possible to obtain Cradle to Cradle “Bronze” certification. This means that at least 75% of all materials used in the BICAR are recyclable. It is furthermore possible to use materials that have a biological cycle, as well as materials that go through a technical cycle. Solutions are available for the steel frame, skin (e.g., polypropylene deep-drawn parts, biological fibre structure plates, etc.), windscreen, solar cells and components for the wheel suspension (steel, aluminium). To date, there is no market solution for Cradle to Cradle tyres (rubber), electronics and batteries. This represents a large field for future research.

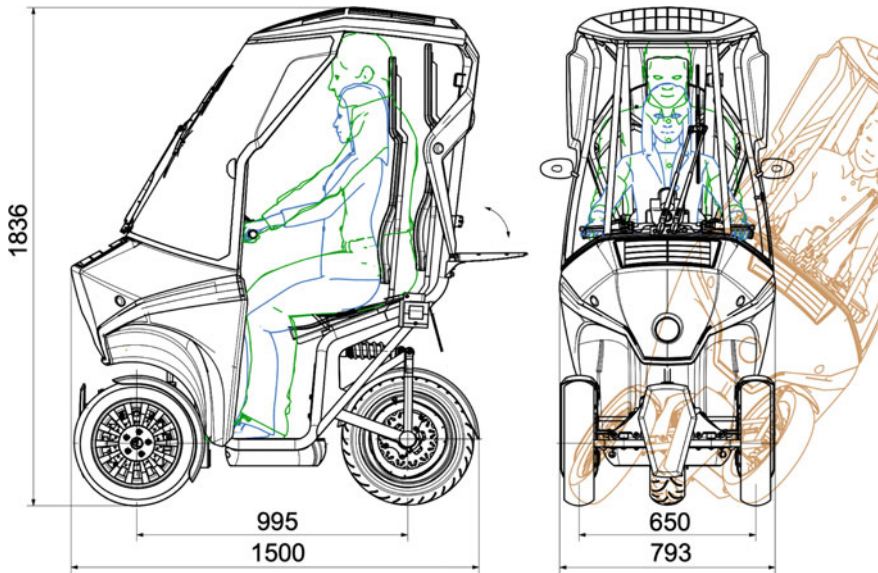

Fig. 2 Layout (numbers in mm) including tilting view and different seat positions (blue: 5% F, green: 95% M)

4 User-Centred Layout Conception

The whole development of the layout is based on a user-centred concept (see Fig. 2) [2]. For this, a tall man (95%M)² and a short woman (5%F)³ were used to modify the ergonomics for the driving position, the location of the steering gear, battery position, interior and exterior design, etc. In order to achieve this, an adjustable seat model was developed that provides an oblique movement in the direction of travel. This allows drivers of different heights to have easy access to the vehicle, to control the vehicle very well when stationary and provides a very good overview while driving. Additionally, the handlebars provide the driver with a firm grip.

²Tall man: 95th percentile man, man of the body height group 95th percentile man.

³Short woman: 5th percentile woman, woman of the body height group 5th percentile woman.

5 Frame and Structure

In order to meet the legal requirements for road approval, the belt anchor points, including the frame, must be subjected to a static load test. The requirements for the test are specified in the 3/2014-EU-Regulations [3].

A force of 6750 ± 200 N acts on the upper belt anchor points and a total force of 6750 ± 200 N also acts on the two lower ones (see Fig. 3). The direction of the acting forces is $\alpha = 10 \pm 5^\circ$ from the horizontal. The frame is firmly clamped at the positions where the front and rear axle chassis is mounted. Here, an additional longitudinal force must be exerted which is ten times the seat weight. The frame is allowed to deform plastically during the test and connections may partially break or crack.

The finite element method (FEM) [4] analysis shows the main load points 1 and 2 (see Fig. 3). S355 steel is used for the main load-bearing tubing and plates. S235 is used for the tubing which is less load bearing; this mainly serves as a supporting structure. At no point is the yield strength or the permissible deformation reached. To verify these calculations, a non-destructive test was carried out with a frame and a clamping system as described in the FEM.

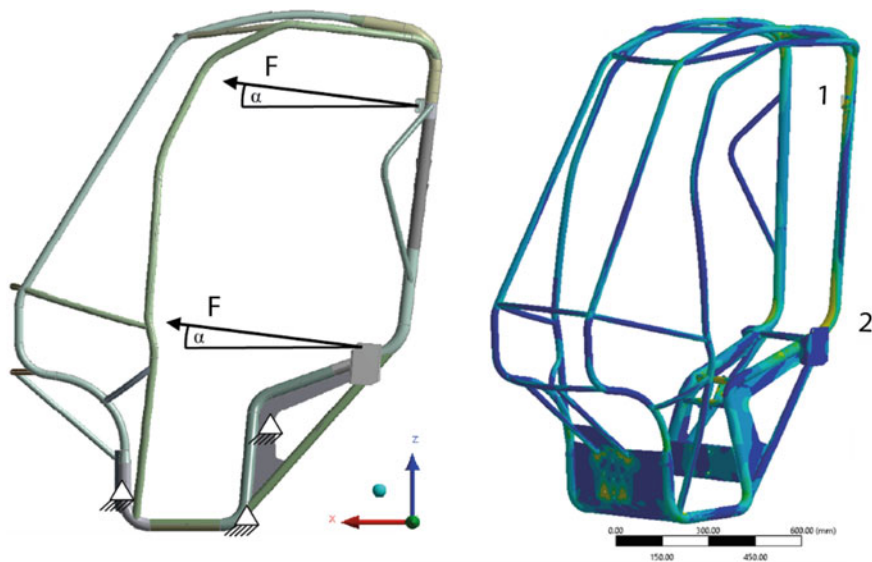

Fig. 3 Structure and stressed areas (*right*)

6 Chassis

During the development of the chassis, special emphasis was placed on a bicycle-like ride behaviour. So, the BICAR tilts when cornering, analogous to the cornering action of a bicycle. This enables fast habituation and ensures safety. The three-wheel construction and the tilting mechanism ensure high manoeuvrability and stability even on slippery road surfaces. For optimum handling, the BICAR has been equipped with a mechanism that allows the vehicle to tilt up to 35° when cornering.

The tilting mechanism has been developed specifically for the BICAR, since existing tilting mechanisms on the market are either unstable and produce unwanted steering forces, making the vehicle difficult to handle, or are far too heavy due to their design for motorcycles with a maximum speed of >120 km/h. The BICAR tilting mechanism is based on a double wishbone suspension with isosceles wishbones and has a very light and cost-efficient construction (see Fig. 4). By connecting the two wheels through a parallelogram formed by the upper and lower wishbones, the wheels always tilt equally. The steering is based on the Ackermann principle and is implemented by means of two track rods. The maximum steering angle of the wheels is 30° . The zero track ensures a secure directional stability in combination with the inclination of the whole vehicle. This allows a very agile and yet stable handling. The horizontal spring-damper unit acting on both sides absorbs axial shocks caused by uneven road surfaces.

The front suspension also includes a tilt brake, which can be activated either automatically or as required when the vehicle is stationary or moving slowly. It is based on a friction-locked principle.

Figure 5 shows the rear wheel suspension in detail. This is a one-sided swing system that enables the motor to be easily replaced in case of damage or for

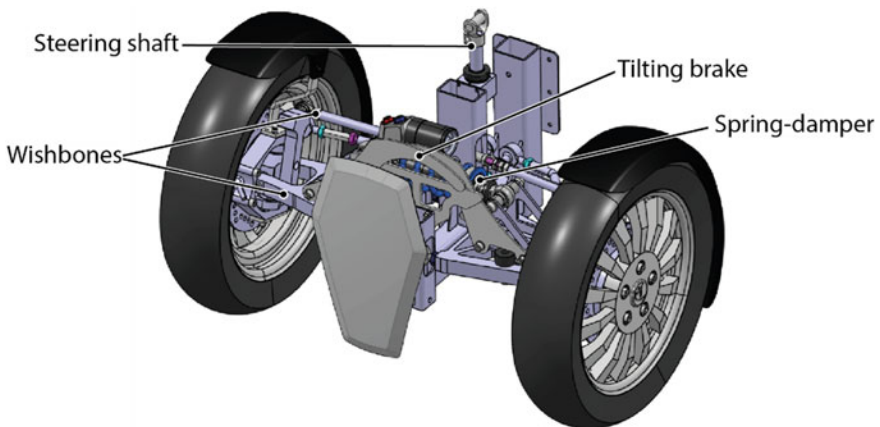

Fig. 4 Isometric views of the front chassis

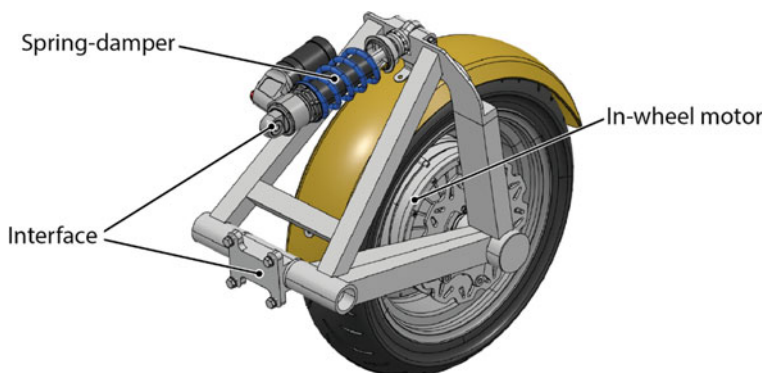

Fig. 5 Isometric view of the rear suspension with strut (brakes not shown)

maintenance purposes. The rear suspension is attached to the chassis via a lower joint and the spring-damper component. The rear wheel also includes a driving brake and a mandatory parking brake. As with the frame, the chassis structure is a welded construction made of different steels.

7 Energy Management

When considering vehicle sharing solutions, an important criterion for the profitability of the business model is the ubiquitous availability of a vehicle. For electrically powered vehicles, an innovative solution is therefore necessary so that the user can borrow a vehicle with enough range for their desired journey at any time. With the BICAR, several solutions were integrated which have advantages depending on the operating model and location of use.

The battery in the BICAR is exchangeable and installed in the foot compartment. The battery, which weighs less than 8 kg, can be removed by any user, if necessary, and replaced with a charged battery at a battery changing station. Battery changing and charging stations could be set up at defined locations within a city network. The battery could also be replaced by a service team circulating from BICAR to BICAR with charged batteries and replacing the low batteries promptly in time. This service model would be feasible with BICAR used in a free-floating system. This would entail the user being allowed to park the vehicles anywhere within a defined geo-fence (e.g., urban areas or defined parking zones). At these locations, however, charging stations would not be available. In a fixed station-based operating concept, charging points could be installed, so that the vehicle could also be charged via a plug-in power cable.

To this date, the BICAR is the only L2e sharing vehicle on the market with solar cells integrated in the weather protection hood. This surface is large enough to

recharge up to a third of the battery capacity. This additional charging facility directly reduces service operations and frequency of battery changes, thus reducing operating costs. The power absorbed by the solar panels depends on the geographical location of the site, season, local weather and the local building architecture (shading of streets). In favourable locations (Southern Europe, South Asia, Central America), the BICAR can be operated all year round as a 100% energy self-sufficient solution, using only solar power.

8 Conclusion

Share your BICAR AG develops and sells new electric mobility solutions optimised for short and medium distances in urban areas. The technology of the BICAR described here is the result of several years of work and technical adjustment after numerous tests with users, customers and experts. Share your BICAR does not act as a sharing provider but as a vehicle manufacturer. For more information: see www.bicar.ch.

At the beginning of the developments, it was not clear whether a vehicle like BICAR with its main functions (see Fig. 1; Chapter “[Small Electric Vehicles—Benefits and Drawbacks for Sustainable Urban Development](#)”) is satisfactory and drivable from the users’ point of view. The construction of several prototypes, the presentation at the Geneva Motor Show 2019 and the subsequent test drives with numerous people have proven this.

The weather protection, the agile and safe driving (belt system, 3-wheel chassis) could be tested in numerous rides. In this context, it was confirmed that especially in urban areas, the use of the BICAR can offer an added value. This article describes the use of the BICAR for sharing providers. Of course, the BICAR can also be used for business fleets or private use.

References

1. Dennig DH-J, Sauter-Servaes DT, Hoppe DM, Burri A (2016) World light electric vehicle summit Barcelona, 20 and 21 September, p 8
2. Mueller A, Maier T, Dennig H-J (2011) Holistic and user-centered layout conception of an electric vehicle (E-Car). Stuttgart, pp 93–106
3. Regulation (EU) No 3/2014. Vehicle functional safety requirements for the approval of two- or three-wheel vehicles and quadricycles, October 24, 2013
4. Steinke, P.: Finite-elemente-methode, 2. Springer, Berlin, Heidelberg, New York (2007)

Open Access This chapter is licensed under the terms of the Creative Commons Attribution 4.0 International License (<http://creativecommons.org/licenses/by/4.0/>), which permits use, sharing, adaptation, distribution and reproduction in any medium or format, as long as you give appropriate credit to the original author(s) and the source, provide a link to the Creative Commons license and indicate if changes were made.

The images or other third party material in this chapter are included in the chapter's Creative Commons license, unless indicated otherwise in a credit line to the material. If material is not included in the chapter's Creative Commons license and your intended use is not permitted by statutory regulation or exceeds the permitted use, you will need to obtain permission directly from the copyright holder.

