

Walter Leal Filho  
*Editor-in-Chief*

Nicholas Oguge · Desalegn Ayal  
Lydia Adeleke · Izael da Silva  
*Editors*

# African Handbook of Climate Change Adaptation

OPEN ACCESS

 Springer

---

# African Handbook of Climate Change Adaptation

---

Walter Leal Filho  
Editor-in-Chief

Nicholas Oguge • Desalegn Ayal •  
Lydia Adeleke • Izael da Silva  
Editors

# African Handbook of Climate Change Adaptation

With 610 Figures and 361 Tables

 Springer

*Editor-in-Chief*

Walter Leal Filho  
Research and Transfer Centre  
“Sustainable Development and  
Climate Change Management”  
Hamburg University of Applied Sciences  
Hamburg, Germany

*Editors*

Nicholas Oguge  
University of Nairobi  
Nairobi, Kenya

Desalegn Ayal  
Center for Food Security Studies  
College of Development Studies  
Addis Ababa University  
Addis Ababa, Ethiopia

Lydia Adeleke  
Department of Fisheries and  
Aquaculture Technology  
Federal University of Technology  
Akure, Nigeria

Izael da Silva  
Strathmore University  
Nairobi, Kenya



ISBN 978-3-030-45105-9

ISBN 978-3-030-45106-6 (eBook)

ISBN 978-3-030-45107-3 (print and electronic bundle)

<https://doi.org/10.1007/978-3-030-45106-6>

© The Editor(s) (if applicable) and The Author(s) 2021

This book is an open access publication.

**Open Access** This book is licensed under the terms of the Creative Commons Attribution 4.0 International License (<http://creativecommons.org/licenses/by/4.0/>), which permits use, sharing, adaptation, distribution and reproduction in any medium or format, as long as you give appropriate credit to the original author(s) and the source, provide a link to the Creative Commons license and indicate if changes were made.

The images or other third party material in this book are included in the book's Creative Commons license, unless indicated otherwise in a credit line to the material. If material is not included in the book's Creative Commons license and your intended use is not permitted by statutory regulation or exceeds the permitted use, you will need to obtain permission directly from the copyright holder.

The use of general descriptive names, registered names, trademarks, service marks, etc. in this publication does not imply, even in the absence of a specific statement, that such names are exempt from the relevant protective laws and regulations and therefore free for general use.

The publisher, the authors, and the editors are safe to assume that the advice and information in this book are believed to be true and accurate at the date of publication. Neither the publisher nor the authors or the editors give a warranty, expressed or implied, with respect to the material contained herein or for any errors or omissions that may have been made. The publisher remains neutral with regard to jurisdictional claims in published maps and institutional affiliations.

This Springer imprint is published by the registered company Springer Nature Switzerland AG.  
The registered company address is: Gewerbestrasse 11, 6330 Cham, Switzerland

---

## Preface

Climate change is a major global challenge. However, some geographical regions are more affected than others. One of these regions is the African continent. Due to a combination of unfavorable socioeconomic and meteorological conditions, African countries are particularly vulnerable to climate change and its impacts. The IPCC Special Report “Global Warming by 1.5 °C” outlines the fact that maintaining global warming by 1.5 °C is possible, but also points out that a 2 °C increase could lead to crises in agriculture (rain-fed agriculture could decline by 50% in some African countries by 2020) and livestock, damage water supplies, and pose an additional threat to coastal areas.

The IPCC also predicts that wheat could disappear from Africa by 2080 and that maize – a staple food – may decline significantly in southern Africa. In addition, arid and semi-arid soils are likely to increase by up to 8%, which will have serious implications for livelihoods, poverty reduction, and meeting the UN Sustainable Development Goals. Pursuing appropriate adaptation strategies is therefore crucial to meet the current and future challenges posed by climate change.

Despite recent progress since the signing of the Paris Agreement in 2015 and the Katowice climate package in 2018, there is still much to be done to raise awareness on the relevance of climate issues for African nations. This process of awareness raising could be supported by specialized publications written by African experts (or by experts working in the region), based on the realities on the African continent, and comprehensively documenting and disseminating the many ideas, approaches, methods, and projects being implemented across Africa today.

Based on the need to address the above issues that the *African Handbook of Climate Change Adaptation* has been produced. It discusses current thinking and presents some of the main issues and challenges related to climate change in Africa, as well as evidences from a wide range of studies and projects that show how climate change adaptation is being – and can continue to be – successfully implemented in African countries. Thanks to its scope and wide range of topics related to climate change, this book is intended to become a flagship publication on the subject.

This handbook shares some of the latest research findings on climate change and its impacts in Africa. And apart from having provided senior African researchers and representatives from government and non-governmental organizations with a platform for the documentation and dissemination of their work, it provides an

opportunity for young scholars from Africa to present their research and climate adaptation projects. Some special features of the publication are:

1. Over 100 scientific contributions written by African researchers and/or researchers based in Africa
2. All contributions have been peer reviewed by an international editorial team consisting of editors, associate editors, and reviewers
3. It represents all African regions and contexts, from North, East, and West Africa to Southern Africa.

The body of information and knowledge which characterizes the *African Handbook of Climate Change Adaptation* is of particular value to: early career and established researchers whose research and studies examine aspects related to climate change and climate change mitigation and adaptation in Africa; social institutions working on climate change and climate adaptation in Africa that need new information; nongovernmental organizations (NGOs); associations and companies, especially from the finance and insurance sectors; government institutions (ministries of the environment, planning committees, etc.); international and national aid organizations; and other actors in Africa whose activities are affected by climate change.

The handbook provides an overview of the impacts of climate change on the African continent and the methods currently being used to implement climate change adaptation. The experiences from the contributors will also be useful for international and regional experts working in the field of climate change and planning, as well as for all those interested in the linkages between climate change and climate adaptation. In order to support the training of a new generation of scientists, the *African Handbook of Climate Change Adaptation* will be especially used by young scientists (M.Sc. students, Ph.D. students, and postdoctoral students).

And, as importantly, the fact that this publication is available via open access means that it is free and can be read and used by all those interested on matters related to climate change adaptation in Africa, without any costs. Here, the editors would like to thank the assistance provided by the German Ministry for International Cooperation (BMZ), whose support has made this possible.

The editors would also like to thank the authors for their hard work, their patience during the peer-review process, and willingness to share their knowledge with a wide audience. Thanks are also due to the associate editors and reviewers for dedicating their time in the assessments of their manuscripts. Their support is greatly appreciated.

We hope that the *African Handbook of Climate Change Adaptation* will support the regional and global efforts to assist African nations handle the many challenges posed by a changing climate.

---

## Acknowledgments

We acknowledge the support provided by the German Federal Ministry of Economic Cooperation and Development (Bundesministerium für wirtschaftliche Zusammenarbeit und Entwicklung), which has made it possible to produce the *African Handbook of Climate Change Adaptation* as an open access publication.

The editors also acknowledge the support provided by the International Climate Change Information and Research Programme (ICCIRP) and the staff at the Research and Transfer Centre “Sustainable Development and Climate Change Management” at the Hamburg University of Applied Sciences for the assistance in the promotion and monitoring of the project, as well as in supporting the authors.

---

# Contents

## Volume 1

<b>Part I Climate Change, Agriculture, and Food Security</b> . . . . .	<b>1</b>
<b>1 Adaptation of Seaweed Farmers in Zanzibar to the Impacts of Climate Change</b> . . . . .	<b>3</b>
Georgia de Jong Cleyndert, Rebecca Newman, Cecile Brugere, Aida Cuni-Sanchez, and Robert Marchant	
<b>2 Adaptation of Small-Scale Tea and Coffee Farmers in Kenya to Climate Change</b> . . . . .	<b>29</b>
Alice Nyawira Karuri	
<b>3 Adaptive Capacity to Mitigate Climate Variability and Food Insecurity of Rural Communities Along River Tana Basin, Kenya</b> . . . . .	<b>49</b>
David Karienyee and Joseph Macharia	
<b>4 Agricultural Interventions to Enhance Climate Change Adaptation of Underutilized Root and Tuber Crops</b> . . . . .	<b>61</b>
Joseph P. Gweyi-Onyango, Michael Ajanja Sakha, and Joyce Jefwa	
<b>5 Farmers' Adaptive Capacity to Climate Change in Africa: Small-Scale Farmers in Cameroon</b> . . . . .	<b>87</b>
Nyong Princely Awazi, Martin Ngankam Tchamba, Lucie Felicite Temgoua, and Marie-Louise Tientcheu-Avana	
<b>6 Assessment of Farmers' Indigenous Technology Adoptions for Climate Change Adaptation in Nigeria</b> . . . . .	<b>117</b>
Idowu Ologeh, Francis Adesina, and Victor Sobanke	
<b>7 Case for Climate Smart Agriculture in Addressing the Threat of Climate Change</b> . . . . .	<b>131</b>
John Saviour Yaw Eleblu, Eugene Tenkorang Darko, and Eric Yirenkyi Danquah	



<b>8 Sorghum Farmers' Climate Change Adaptation Strategies in the Semi-arid Region of Cameroon</b> .....	147
Salé Abou, Madi Ali, Anselme Wakponou, and Armel Sambo	
<b>9 Attaining Food Security in the Wake of Climatic Risks: Lessons from the Delta State of Nigeria</b> .....	167
Eromose E. Ebhuoma	
<b>10 Tied Ridges and Better Cotton Breeds for Climate Change Adaptation</b> .....	181
R. Mandumbu, C. Nyawenze, J. T. Rugare, G. Nyamadzawo, C. Parwada, and H. Tibugari	
<b>11 Determinants of Cattle Farmers' Perception of Climate Change in the Dry and Subhumid Tropical Zones of Benin (West Africa)</b> .....	197
Yaya Idrissou, Alassan Seidou Assani, Mohamed Nasser Baco, and Ibrahim Alkoiret Traoré	
<b>12 Drivers of Level of Adaptation to Climate Change in Smallholder Farming Systems in Southern Africa: A Multilevel Modeling Approach</b> .....	213
Byron Zamasiya, Kefasi Nyikahadzoi, and Billy Billiard Mukamuri	
<b>13 Economic Analysis of Climate-Smart Agriculture Technologies in Maize Production in Smallholder Farming Systems</b> .....	225
Angeline Mujeyi and Maxwell Mudhara	
<b>14 Role of Cassava and Sweetpotato in Mitigating Drought in Semi-Arid Makueni County in Kenya</b> .....	241
C. M. Githunguri and E. N. Njiru	
<b>15 Food Security Concerns, Climate Change, and Sea Level Rise in Coastal Cameroon</b> .....	261
Wilfred A. Abia, Comfort A. Onya, Conalius E. Shum, Williette E. Amba, Karen L. Niba, and Eucharia A. Abia	
<b>16 Impacts of Climate Change to Poultry Production in Africa: Adaptation Options for Broiler Chickens</b> .....	275
M. O. Abioja and J. A. Abiona	
<b>17 Climate Change Adaptation Options in Farming Communities of Selected Nigerian Ecological Zones</b> .....	297
Ayansina Ayanlade, Isaac Ayo Oluwatimilehin, Adeola A. Oladimeji, Godwin Atai, and Damilola T. Agbalajobi	
<b>18 Plants and Plant Products in Local Markets Within Benin City and Environs</b> .....	315
Moses Edwin Osawaru and Matthew Chidozie Ogwu	

<b>19</b>	<b>Retooling Smallholder Farming Systems for Climate Change Resilience Across Botswana Arid Zones</b> .....	339
	Nnyaladzi Batisani, Flora Pule-Meulenberg, Utlwang Batlang, Federica Matteoli, and Nelson Tselaesele	
<b>20</b>	<b>Agroecology and Climate Change Adaptation: Farmers' Experiences in the South African Lowveld</b> .....	363
	Cryton Zazu and Anri Manderson	
<b>21</b>	<b>Climate Change and Variability on Food Security of Rural Household: Central Highlands, Ethiopia</b> .....	379
	Argaw Tesfaye and Arragaw Alemayehu	
<b>22</b>	<b>Intangible and Indirect Costs of Adaptation to Climate Variability Among Maize Farmers: Chirumanzu District, Zimbabwe</b> .....	397
	Dumisani Shoko Kori, Joseph Francis, and Jethro Zuwarimwe	
<b>23</b>	<b>Climate Variability and Rural Livelihood Security: Impacts and Implications</b> .....	423
	Kehinde Olayinka Popoola, Anne Jerneck, and Sunday Adesola Ajayi	
<b>24</b>	<b>Climate Change Impact on Soil Moisture Variability: Health Effects of Radon Flux Density Within Ogbomoso, Nigeria</b> .....	437
	Olukunle Olaonipekun Oladapo, Leonard Kofitse Amekudzi, Olatunde Micheal Oni, Abraham Adewale Aremu, and Marian Amoakowaah Osei	
<b>25</b>	<b>African Yam Bean the Choice for Climate Change Resilience: Need for Conservation and Policy</b> .....	453
	C. V. Nnamani, D. B. Adewale, H. O. Oselebe, and C. J. Atkinson	
<b>26</b>	<b>Underutilized Indigenous Vegetables' (UIVs) Business in Southwestern Nigeria: Climate Adaptation Strategies</b> .....	471
	V. A. Tanimonure	
<b>27</b>	<b>Farmers' Adoption of Climate Smart Practices for Increased Productivity in Nigeria</b> .....	495
	B. E. Fawole and S. A. Aderinoye-Abdulwahab	
<b>28</b>	<b>Climate Change Adaptation Strategies Among Cereal Farmers in Kwara State, Nigeria</b> .....	509
	S. A. Aderinoye-Abdulwahab and T. A. Abdulbaki	
<b>29</b>	<b>Dual Pathway Model of Responses Between Climate Change and Livestock Production</b> .....	523
	Adetunji Oroye Iyiola-Tunji, James Ijampy Adamu, Paul Apagu John, and Idris Muniru	

<b>30</b>	<b>Corona Virus, Climate Change, and Food Security</b> .....	<b>563</b>
	Nkiru Theresa Meludu and Toyin Abolade	
<b>31</b>	<b>Role of Small Grains in Adapting to Climate Change: Zvishavane District, Zimbabwe</b> .....	<b>581</b>
	Tendai Nciizah, Elinah Nciizah, Caroline Mubekaphi, and Adornis D. Nciizah	
<b>32</b>	<b>Constraints to Farmers' Choice of Climate Change Adaptation Strategies in Ondo State of Nigeria</b> .....	<b>601</b>
	George Olanrewaju Ige, Oluwole Matthew Akinnagbe, Olalekan Olamigoke Odefadehan, and Opeyemi Peter Ogunbusuyi	
<b>33</b>	<b>Maize, Cassava, and Sweet Potato Yield on Monthly Climate in Malawi</b> .....	<b>617</b>
	Floney P. Kawaye and Michael F. Hutchinson	
<b>34</b>	<b>Addressing Climate Change Vulnerability Through Small Livestock Rearing in Matobo, Zimbabwe</b> .....	<b>639</b>
	Keith Phiri, Sibonokuhle Ndlovu, Moreblessings Mpofo, Philani Moyo, and Henri-Count Evans	
<b>35</b>	<b>Barriers to Climate Change Adaptation Among Pastoralists: Rwenzori Region, Western Uganda</b> .....	<b>659</b>
	Michael Robert Nkuba, Raban Chanda, Gagoitsope Mmopelwa, Akintayo Adedoyin, Margaret Najjingo Mangheni, David Lesolle, and Edward Kato	
<b>36</b>	<b>Rethinking Climate-Smart Agriculture Adoption for Resilience-Building Among Smallholder Farmers: Gender-Sensitive Adoption Framework</b> .....	<b>677</b>
	Sizwile Khoza, Dewald van Niekerk, and Livhuwani NemaKonde	
<b>37</b>	<b>Rainfall Variability and Adaptation of Tomatoes Farmers in Santa: Northwest Region of Cameroon</b> .....	<b>699</b>
	Majoumo Christelle Malyse	
<b>38</b>	<b>Rainfall Variability and Quantity of Water Supply in Bamenda I, Northwest Region of Cameroon</b> .....	<b>713</b>
	Zoyem Tedonfack Sedrique and Julius Tata Nfor	
<b>39</b>	<b>Climate Change Adaptation: Implications for Food Security and Nutrition</b> .....	<b>735</b>
	Caroline Fadeke Ajilogba and Sue Walker	
<b>40</b>	<b>Brachiaria Grass for Climate Resilient and Sustainable Livestock Production in Kenya</b> .....	<b>755</b>
	D. M. G. Njarui, M. Gatheru, and S. R. Ghimire	

<b>41</b>	<b>Climate Change Adaptation Through Sustainable Water Resources Management in Kenya: Challenges and Opportunities</b> .....	<b>777</b>
	Shilpa Muliylil Asokan, Joy Obando, Brian Felix Kwena, and Cush Ngonzo Luwesi	
<b>42</b>	<b>Impacts of Environmental Change on Fish Production in Egypt and Nigeria: Technical Characteristics and Practice</b> .....	<b>789</b>
	M. L. Adeleke, D. Al-Kenawy, A. M. Nasr-Allah, M. Dickson, and Desalegn Ayal	
<b>Part II</b>	<b>Climate Change, Technologies, and Resources Management</b> .....	<b>807</b>
<b>43</b>	<b>Sustainable Urban Drainage Practices and Their Effects on Aquifer Recharge</b> .....	<b>809</b>
	Getrude Gichuhi and Stephen Gitahi	
<b>44</b>	<b>Building Livelihoods Resilience in the Face of Climate Change: Case Study of Small-Holder Farmers in Tanzania</b> .....	<b>829</b>
	Saumu Ibrahim Mwashwa and Zoe Robinson	
<b>45</b>	<b>Climate Change Adaptation: Opportunities for Increased Material Recycling Facilities in African Cities</b> .....	<b>849</b>
	Gamuchirai Mutezo, Jean Mulopo, and Dumisani Chirambo	
<b>Volume 2</b>		
<b>46</b>	<b>Farm-Level Impacts of Greenhouse Gas Reductions for the Predominant Production Systems in Northern Nigeria</b> .....	<b>875</b>
	Taiwo B. Ayinde, Benjamin Ahmed, and Charles F. Nicholson	
<b>47</b>	<b>GIS-Based Assessment of Solar Energy Harvesting Sites and Electricity Generation Potential in Zambia</b> .....	<b>899</b>
	Mabvuto Mwanza and Koray Ulgen	
<b>48</b>	<b>Panel Analysis of the Relationship Between Weather Variability and Sectoral Output in Kenya</b> .....	<b>947</b>
	Olga Nekesa Mulama and Caroline Wanjiru Kariuki	
<b>49</b>	<b>Agro-ecological Lower Midland Zones IV and V in Kenya Using GIS and Remote Sensing for Climate-Smart Crop Management</b> .....	<b>965</b>
	Hilda Manzi and Joseph P. Gweyi-Onyango	
<b>50</b>	<b>Water Resource Management Frameworks in Water-Related Adaptation to Climate Change</b> .....	<b>993</b>
	Godfrey Odongtoo, Denis Ssebugwawo, and Peter Okidi Lating	

<b>51</b>	<b>Retracing Economic Impact of Climate Change Disasters in Africa: Case Study of Drought Episodes and Adaptation in Kenya</b> .....	1007
	Mary Nthambi and Uche Dickson Ijioma	
<b>52</b>	<b>Rural Farmers' Approach to Drought Adaptation: Lessons from Crop Farmers in Ghana</b> .....	1033
	Hillary Dumba, Jones Abrefa Danquah, and Ari Pappinen	
<b>53</b>	<b>Smart Climate Resilient and Efficient Integrated Waste to Clean Energy System in a Developing Country: Industry 4.0</b> ...	1053
	Anthony Njuguna Matheri, Belaid Mohamed, and Jane Catherine Ngila	
<b>54</b>	<b>Greenhouse Gases Emissions in Agricultural Systems and Climate Change Effects in Sub-Saharan Africa</b> .....	1081
	Winnie Ntinyari and Joseph P. Gweyi-Onyango	
<b>55</b>	<b>Use and Impact of Artificial Intelligence on Climate Change Adaptation in Africa</b> .....	1107
	Isaac Rutenberg, Arthur Gwagwa, and Melissa Omino	
<b>56</b>	<b>Impact of Moisture Flux and Vertical Wind Shear on Forecasting Extreme Rainfall Events in Nigeria</b> .....	1127
	Olumide A. Olaniyan, Vincent O. Ajayi, Kamoru A. Lawal, and Ugbah Paul Akeh	
<b>57</b>	<b>Plastic Pollution and Climate Change: Role of Bioremediation as a Tool to Achieving Sustainability</b> .....	1159
	S. A. Idowu, D. J. Arotupin, and S. O. Oladejo	
<b>58</b>	<b>Climate Change, Rural Livelihoods, and Ecosystem Nexus: Forest Communities in Agroecological zones of Nigeria</b> .....	1169
	Olushola Fadairo, Samuel Olajuyigbe, Tolulope Osayomi, Olufolake Adelokun, Olanrewaju Olaniyan, Siji Olutegbe, and Oluwaseun Adeleke	
<b>59</b>	<b>Climate Change, Biodiversity, and Tipping Points in Botswana</b> .....	1193
	Peter Urich, Yinpeng Li, and Sennye Masike	
<b>60</b>	<b>Access to Water Resources and Household Vulnerability to Malaria in the Okavango Delta, Botswana</b> .....	1227
	M. R. Motsholapheko and B. N. Ngwenya	
<b>61</b>	<b>Digital Platforms in Climate Information Service Delivery for Farming in Ghana</b> .....	1247
	Rebecca Sarku, Divine Odame Appiah, Prosper Adiku, Rahinatu Sidiki Alare, and Senyo Dotsey	

---

<b>62</b>	<b>Clean Energy Technology for the Mitigation of Climate Change: African Traditional Myth</b> .....	1279
	Abel Ehimen Airoboman, Patience Ose Airoboman, and Felix Ayemere Airoboman	
<b>63</b>	<b>Green Technology Approaches to Solid Waste Management in the Developing Economies</b> .....	1293
	T. B. Hammed and M. K. C. Sridhar	
<b>64</b>	<b>Pyrolysis Bio-oil and Bio-char Production from Firewood Tree Species for Energy and Carbon Storage in Rural Wooden Houses of Southern Ethiopia</b> .....	1313
	Miftah F. Kedir	
<b>65</b>	<b>“Conservation Agriculture,” Possible Climate Change Adaptation Option in Taita Hills, Kenya</b> .....	1331
	Lilian Motaroki, Gilbert Ouma, and Dorcas Kalele	
<b>66</b>	<b>Do-It-Yourself Flood Risk Adaptation Strategies in the Neighborhoods of Kano City, Nigeria</b> .....	1353
	Aliyu Barau and Aliyu Sani Wada	
<b>67</b>	<b>Global Strategy, Local Action with Biogas Production for Rural Energy Climate Change Impact Reduction</b> .....	1381
	A. S. Momodu, E. F. Aransiola, T. D. Adepoju, and I. D. Okunade	
<b>68</b>	<b>Biochar for Climate Change Adaptation: Effect on Heavy Metal Composition of <i>Telfairia occidentalis</i> Leaves</b> .....	1401
	Doris Akachukwu, Michael Adedapo Gbadegesin, Philippa Chinyere Ojmelukwe, and Christopher John Atkinson	
<b>69</b>	<b>Sustaining a Cleaner Environment by Curbing Down Biomass Energy Consumption</b> .....	1423
	Abubakar Hamid Danlami and Shri Dewi Applanaidu	
<b>70</b>	<b>Resetting the African Smallholder Farming System: Potentials to Cope with Climate Change</b> .....	1441
	Bernhard Freyer and Jim Bingen	
<b>71</b>	<b>Sustainable Food Production Systems for Climate Change Mitigation: Indigenous Rhizobacteria for Potato Bio-fertilization in Tanzania</b> .....	1469
	Becky Nancy Aloo, Ernest Rashid Mbega, and Billy Amendi Makumba	
<b>72</b>	<b>Climate Change Adaptation Among Smallholder Farmers in Rural Ghana</b> .....	1497
	Peter Asare-Nuamah and Athanasius Fonteh Amungwa	

<b>73</b>	<b>Biomass Burning Effects on the Climate over Southern West Africa During the Summer Monsoon</b> .....	1515
	Alima Dajuma, Siélé Silué, Kehinde O. Ogunjobi, Heike Vogel, Evelynne Touré N'Datchoh, Véronique Yoboué, Arona Diedhiou, and Bernhard Vogel	
<b>74</b>	<b>Precipitation Variability in West Africa in the Context of Global Warming and Adaptation Recommendations</b> .....	1533
	Gandome Mayeul L. D. Quenum, Nana A. B. Klutse, Eric A. Alamou, Emmanuel A. Lawin, and Philip G. Oguntunde	
<b>75</b>	<b>Socioeconomically Informed Use of Geostatistics to Track Adaptation of Resource-Poor Communities to Climate Change</b> .....	1555
	Martin Munashe Chari, Hamisai Hamandawana, and Leocadia Zhou	
<b>76</b>	<b>Risks of Indoor Overheating in Low-Cost Dwellings on the South African Lowveld</b> .....	1583
	Newton R. Matandirotya, Dirk P. Cilliers, Roelof P. Burger, Christian Pauw, and Stuart J. Piketh	
<b>77</b>	<b>Smallholders Use of Weather Information as Smart Adaptation Strategy in the Savannah Area of Ondo State, Nigeria</b> .....	1601
	Rasheedat Alligbor, David Olufemi Awolala, and Igbekele Amos Ajibefun	
<b>78</b>	<b>ECMWF Subseasonal to Seasonal Precipitation Forecast for Use as a Climate Adaptation Tool Over Nigeria</b> .....	1613
	Ugbah Paul Akeh, Steve Woolnough, and Olumide A. Olaniyan	
<b>79</b>	<b>Agropastoralists' Climate Change Adaptation Strategy Modeling: Software and Coding Method Accuracies for Best-Worst Scaling Data</b> .....	1631
	Zakou Amadou	
<b>80</b>	<b>Barriers to the Adoption of Improved Cooking Stoves for Rural Resilience and Climate Change Adaptation and Mitigation in Kenya</b> .....	1641
	Daniel M. Nzengya, Paul Maina Mwari, and Chrocociscus Njeru	
<b>81</b>	<b>Improving Food Security by Adapting and Mitigating Climate Change-Induced Crop Pest: The Novelty of Plant-Organic Sludge in Southern Nigeria</b> .....	1659
	Chukwudi Nwaogu	

<b>82</b>	<b>Indigenous and Scientific Forecasts on Climate Change Perceptions of Arable Farmers: Rwenzori Region, Western Uganda</b> .....	<b>1685</b>
	Michael Robert Nkuba, Raban Chanda, Gagoitseope Mmopelwa, Akintayo Adedoyin, Margaret Najjingo Mangheni, David Lesolle, and Edward Kato	
<b>83</b>	<b>Thermodynamic Environment During the 2009 Burkina Faso and 2012 Nigeria Flood Disasters: Case Study</b> .....	<b>1705</b>
	R. Ayodeji Balogun, E. Adesanya Adefisan, Z. Debo Adeyewa, and E. Chilekwu Okogbue	
<b>84</b>	<b>Differential Impact of Land Use Types on Soil Productivity Components in Two Agro-ecological Zones of Southern Ghana</b> .....	<b>1721</b>
	Folasade Mary Owode, Samuel Godfried Kwasi Adiku, Christopher John Atkinson, and Dilys Sefakor MacCarthy	
<b>85</b>	<b>Data Collection Using Wireless Sensor Networks and Online Visualization for Kitui, Kenya</b> .....	<b>1735</b>
	Josephine Mbandi and Michael Kisangari	
<b>Part III</b>	<b>Interdisciplinary Aspects of Climate Change</b> .....	<b>1749</b>
<b>86</b>	<b>Climate Change Adaptation in Southern Africa: Universalistic Science or Indigenous Knowledge or Hybrid</b> .....	<b>1751</b>
	Tafadzwa Mutambisi, Nelson Chanza, Abraham R. Matamanda, Roseline Ncube, and Innocent Chirisa	
<b>87</b>	<b>Equity and Justice in Climate Change Adaptation: Policy and Practical Implication in Nigeria</b> .....	<b>1767</b>
	Chinwe Philomina Oramah and Odd Einar Olsen	
<b>88</b>	<b>Climate-Induced Food Crisis in Africa: Integrating Policy and Adaptation</b> .....	<b>1789</b>
	David O. Chiawo and Verrah A. Otiende	
<b>89</b>	<b>Gender Implications of Farmers' Indigenous Climate Change Adaptation Strategies Along Agriculture Value Chain in Nigeria</b> .....	<b>1811</b>
	Olanike F. Deji	
<b>Volume 3</b>		
<b>90</b>	<b>Impact of Climate Change on Animal Health, Emerging and Re-emerging Diseases in Africa</b> .....	<b>1835</b>
	Royford Magiri, Kaampwe Muzandu, George Gitau, Kennedy Choongo, and Paul Iji	



<b>91</b>	<b>Livestock Breeders' Adaptation to Climate Variability and Change in Morocco's Arid Rangelands</b> .....	1853
	Wadii Snaibi and Abdelhamid Mezrhah	
<b>92</b>	<b>Triple Helix as a Strategic Tool to Fast-Track Climate Change Adaptation in Rural Kenya: Case Study of Marsabit County</b> ...	1873
	Izael da Silva, Daniele Bricca, Andrea Micangeli, Davide Fioriti, and Paolo Cherubini	
<b>93</b>	<b>Climate Change Adaptation Mechanism for Sustainable Development Goal 1 in Nigeria: Legal Imperative</b> .....	1897
	Erimma Gloria Orié	
<b>94</b>	<b>Climate Variability on Fishing Activities in Inland Waters: Case of Owena River in Ondo and Osun States, Nigeria</b> .....	1919
	Lydia Adeleke, Jacob Victor Jerry, Desalegn Ayal, Akinola Joshua Oluwatobi, Ayodele Idowu Sunday, and Ajibefun Igbekele Amos	
<b>95</b>	<b>Climate Change Impact on Climate Extremes and Adaptation Strategies in the Veá Catchment, Ghana</b> .....	1937
	Isaac Larbi, Clement Nyamekye, Fabien C. C. Hountondji, Gloria C. Okafor, and Peter Rock Ebo Odoom	
<b>96</b>	<b>Climate Change Resistant Energy Sources for Global Adaptation</b> .....	1955
	Oluwatobi Ololade Ife-Adediran and Oluyemi Bright Aboyewa	
<b>97</b>	<b>Uncertainties in Rainfall and Water Resources in Maghreb Countries Under Climate Change</b> .....	1967
	Mohamed Meddi and Saeid Eslamian	
<b>98</b>	<b>Hydrological Dynamics Assessment of Basin Upstream–Downstream Linkages Under Seasonal Climate Variability</b> .....	2005
	Oseni Taiwo Amoo, Hamed Olabode Ojugbele, Abdultaofeek Abayomi, and Pushpendra Kumar Singh	
<b>99</b>	<b>Adaptation to Climate Change: Opportunities and Challenges from Zambia</b> .....	2025
	Jonty Rawlins and Felix Kanungwe Kalaba	
<b>100</b>	<b>Gendered Vulnerability to Climate Change Impacts in Selected Counties in Kenya</b> .....	2045
	Daniel M. Nzengya and John Kibe Maguta	
<b>101</b>	<b>Unlocking Climate Finance Potential for Climate Adaptation: Case of Climate Smart Agricultural Financing in Sub Saharan Africa</b> .....	2063
	Edward M. Mungai, S. Wagura Ndiritu, and Izael da Silva	

---

<b>102</b>	<b>Africa–European Union Climate Change Partnership</b> . . . . .	2085
	Oluwole Olutola	
<b>103</b>	<b>Gender and Climate Change Adaptation Among Rural Households in Nigeria</b> . . . . .	2099
	Chukwuma Otum Ume, Patience Ifeyinwa Opata, and Anthony Nwa Jesus Onyekuru	
<b>104</b>	<b>Local Institutions, Collective Action, and Divergent Adaptation: Case from Agro-Pastoral Niger</b> . . . . .	2117
	Julie Snorek	
<b>105</b>	<b>Climatepreneurship: Adaptation Strategy for Climate Change Impacts on Rural Women Entrepreneurship Development in Nigeria</b> . . . . .	2143
	C. A. O. Akinbami	
<b>106</b>	<b>Intersectional Perspective of Strengthening Climate Change Adaptation of Agrarian Women in Cameroon</b> . . . . .	2169
	Faith Ngum and Johan Bastiaensen	
<b>107</b>	<b>Multifunctional Landscape Transformation of Urban Idle Spaces for Climate Resilience in Sub-Saharan Africa</b> . . . . .	2193
	David O. Yawson, Michael O. Adu, Paul A. Asare, and Frederick A. Armah	
<b>108</b>	<b>Climate Change Impact and Adaptation: Lagoonal Fishing Communities in West Africa</b> . . . . .	2221
	K. Sian Davies-Vollum, Debadayita Raha, and Daniel Koomson	
<b>109</b>	<b>Climate Change Implications and Mitigation in a Hyperarid Country: A Case of Namibia</b> . . . . .	2247
	Hupenyu A. Mupambwa, Martha K. Hausiku, Andreas S. Namwoonde, Gadaffi M. Liswaniso, Mayday Haulofu, and Samuel K. Mafwila	
<b>110</b>	<b>Social Vulnerability of Rural Dwellers to Climate Variability: Akwa Ibom State, Nigeria</b> . . . . .	2269
	Jemimah Timothy Ekanem and Idongesit Michael Umoh	
<b>111</b>	<b>Menace and Mitigation of Health and Environmental Hazards of Charcoal Production in Nigeria</b> . . . . .	2293
	Philip Olanrewaju Eniola	
<b>112</b>	<b>Managing Current Climate Variability Can Ensure Water Security Under Climate Change</b> . . . . .	2311
	Mike Muller	

<b>113</b>	<b>Community Adaptation to Climate Change: Case of Gumuz People, Metekel Zone, Northwest Ethiopia</b> .....	2339
	Abbebe Marra Wagino and Teshale W. Amanuel	
<b>114</b>	<b>Impacts of Climate Change on the Hydro-Climatology and Performances of Bin El Ouidane Reservoir: Morocco, Africa</b> ...	2363
	Abdellatif Ahbari, Laila Stour, and Ali Agoumi	
<b>115</b>	<b>Urban Flooding, Adaptation Strategies, and Resilience: Case Study of Accra, Ghana</b> .....	2387
	Kwadwo Owusu and Peter Bilson Obour	
<b>116</b>	<b>Barriers to Effective Climate Change Management in Zimbabwe's Rural Communities</b> .....	2405
	Louis Nyahunda and Happy Mathew Tirivangasi	
<b>117</b>	<b><i>Dichrostachys cinerea</i> Growth Rings as Natural Archives for Climatic Variation in Namibia</b> .....	2433
	Benjamin Mapani, Rosemary Shikangalah, Isaac Mapaure, and Aansbert Musimba	
<b>118</b>	<b>Just Societal Transformation: Perspectives of Pastoralists in the Lower Omo Valley in Ethiopia</b> .....	2447
	Sabine Troeger	
<b>119</b>	<b>Impacts of Global Warming on West African Monsoon Rainfall</b> .....	2469
	Imoleayo E. Gbode, Vincent O. Ajayi, Kehinde O. Ogunjobi, Jimy Dudhia, and Changhai Liu	
<b>120</b>	<b>Transformative Adaptations for Health Impacts of Climate Change in Burkina Faso and Kenya</b> .....	2485
	Edmund Yeboah, Aditi Bunker, Peter Dambach, Isabel Mank, Raïssa Sorgho, Ali Sié, Stephen Munga, Till Bärnighausen, and Ina Danquah	
<b>121</b>	<b>Sustainable Climate Change Adaptation in Developing Countries: Role of Perception Among Rural Households</b> .....	2501
	Oluwatosin Oluwasegun Fasina, Emmanuel Chilekwu Okogbue, Oluwatosin Omowunmi Ishola, and Abiodun Adeeko	
<b>122</b>	<b>Bioeconomy as Climate Action: How Ready Are African Countries?</b> .....	2519
	Oluwaseun James Oguntuase and Oluwatosin Benedict Adu	
<b>123</b>	<b>Flood, Livelihood Displacement, and Poverty in Nigeria: Plights of Flood Victims, 2012–2018</b> .....	2535
	Joachim Chukwuma Okafor	

<b>124</b>	<b>Evidence-Based Policy Development: National Adaptation Strategy and Plan of Action on Climate Change for Nigeria (NASPA-CCN)</b> .....	<b>2547</b>
	Robert Ugochukwu Onyeneke, Chinedum Uzoma Nwajiuba, Brent Tegler, and Chinyere Augusta Nwajiuba	
<b>125</b>	<b>Using Inclusive Finance to Significantly Scale Climate Change Adaptation</b> .....	<b>2565</b>
	Robert Wild, Moses Egaru, Mark Ellis-Jones, Barbara Nakangu Bugembe, Ahmed Mohamed, Obadiah Ngigi, Gertrude Ogwok, Jules Roberts, and Sophie Kutegeka	
<b>126</b>	<b>Pathways to Enhance Climate Change Resilience among Pastoral Households in Northern Tanzania</b> .....	<b>2591</b>
	Ronald Boniphace Ndesanjo, Ida Theilade, and Martin Reinhardt Nielsen	
<b>127</b>	<b>Building Capacity to Cope with Climate Change-Induced Resource-Based Conflicts Among Grassroots Communities in Kenya</b> .....	<b>2611</b>
	John Kibe Maguta, Daniel M. Nzungya, Chrocosiscus Mutisya, and Joyce Wairimu	
<b>128</b>	<b>Mainstreaming Climate Adaptation in Mozambican Urban Water, Sanitation, and Drainage Sector</b> .....	<b>2631</b>
	Pedro Muradás, María Puig, Óscar Ruiz, and Josep María Solé	
<b>129</b>	<b>Primary Versus High School Students' Environmental Attitudes and Pro-environmental Behavior: The Case of Embu County, Kenya</b> .....	<b>2653</b>
	Daniel M. Nzungya and Francis Rutere	
<b>130</b>	<b>Identifying and Overcoming Barriers to Climate Change Adaptation in the Seychelles</b> .....	<b>2675</b>
	Daniel Etongo, Vincent Amelie, Angelique Pouponneau, and Walter Leal Filho	
<b>131</b>	<b>Linking Adaptation and Mitigation Toward a Resilient and Robust Infrastructure Sector in Kenya</b> .....	<b>2693</b>
	Onkangi Ruth, David Lagat, and Ondari Lilian	
<b>132</b>	<b>Integrating Climate Adaptation, Poverty Reduction, and Environmental Conservation in Kwale County, Kenya</b> .....	<b>2713</b>
	Chiara Ambrosino, Ben Hufton, Benson Okinyi Nyawade, Harriet Osimbo, and Phaniel Owiti	
<b>133</b>	<b>Land Use Cover Types and Forest Management Options for Carbon in Mabira Central Forest Reserve</b> .....	<b>2733</b>
	Aisha Jjagwe, Vincent Kakembo, and Barasa Bernard	

---

**134 Women Participation in Farmer Managed Natural Regeneration  
for Climate Resilience: Laisamis, Marsabit County, Kenya . . . . . 2755**  
Irene Ojuok and Tharcisse Ndayizigiye

**135 Climate Change Adaptation and Community Development in  
Port Harcourt, Nigeria . . . . . 2775**  
Julie Greenwalt, Michael Dede, Ibinabo Johnson, Prince Nosa,  
Abi Precious, and Barbara Summers

**Index . . . . . 2803**

---

## About the Editor-in-Chief



**Walter Leal Filho** holds the chairs of climate change management at the Hamburg University of Applied Sciences (Germany) and environment and technology at Manchester Metropolitan University (UK). He directs the Research and Transfer Centre “Sustainability Development and Climate Change Management.”

His main research interests are in the fields of sustainable development and climate change, also including aspects of climate change and health. He has over 30 years’ experience on climate change projects in Africa, having worked in many countries across the continent.

---

## About the Editors



**Nicholas Oguge** is a professor of environmental policy at the Centre for Advanced Studies in Environmental Law and Policy (CASELAP), University of Nairobi, where he was a director for 6 years. He is a peer reviewer with NERC (UK) and a past member of the Scientific Review Committee (SRC) at the Socio-Environmental Synthesis Centre (SESYNC), University of Maryland, USA. Professor Oguge is also the founding president of the Ecological Society for Eastern Africa (ESEA) and editorial board member of the *African Journal of Ecology*. He is published widely and has expertise on a wide range of environmental issues. Professor Oguge was a coordinating lead author for the African region during the recent Global Assessments of Biodiversity and Ecosystem Services by IPBES. He has over 27 years of postdoctoral experience spanning academia, research, resource management, project management, and community outreach.



**Desalegn Ayal** is an associate professor of disaster risk management and sustainable development at the Center for Food Security Studies, College of Development Studies, Addis Ababa University. Desalegn holds a Ph. D. degree in geography. Desalegn serves as the deputy editor of the *International Journal of Climate Change Strategies and Management*. He has published more than 40 publications including books, book chapters, and refereed journal articles. He is East Africa vice president for Interconnections for Making Africa Great, Empowered, and Sustainable Initiative. He is a founder and director of Academics Stand Against Poverty (ASAP) Ethiopian Chapter. Desalegn has also presented papers on climate adaptation and related issues at

many international and national conferences. His principal areas of research include climate change adaptation, climate resilience, climate change mitigation and related issues, indigenous weather forecasting, integrated natural resources rehabilitation and management, and livelihoods and food security nexus, among others. He thoroughly understands the link between natural and human-induced hazards with sustainable development, and works hard to familiarize with current tools of climate change impact assessment on livelihood and the wider environment. He has been actively involved in climate resilience and integrated natural resources rehabilitation and management research as well as development interventions to improve food security.



**Lydia Adeleke** is a senior lecturer and researcher with a Ph.D. in agricultural/resource economics (fisheries economist) at the Federal University of Technology, Akure (FUTA), Nigeria. As part of her doctoral studies, Adeleke was awarded a visiting scholar fellowship to the Fisheries Centre, University of British Columbia (UBC), Vancouver, Canada. She is a fellow of the African-German Network of Excellence in Science (AGNES) and a fellow of the African Women in Agriculture Research and Development (AWARD).

Her research focus is on global adaptation of the artisanal/small-scale fisherfolks to climate change in coastal areas. As an AWARD fellow, she ensures greener world for smallholders' farmers, especially women, through sustainable food production to increase income and living and health standards. As a social economist, she has been doing research on climate change adaptation since 2013, especially in the coastal zones, in order to promote their restoration, conservation, and sustainable use.

She successfully convened the hosting of the 3rd World Symposium on Climate Change Adaptation in Nigeria between 11 and 13 September 2019. The first of its kind in Africa, and The Federal University of Technology, Akure (FUTA), was the first University in Nigeria to host this world event.





**Izael da Silva** has a Ph.D. in power systems engineering from the University of Sao Paulo (Brazil). He is a professor at Strathmore University and the deputy vice chancellor – Research and Innovation. He started the Strathmore Energy Research Centre, SERC. The center does training, research, testing, and consultancy in energy. His topics of interest are: renewable energy, energy efficiency, energy policy, and sustainable environment. He was also instrumental in the setting up of a project sponsored by DFID and DANIDA and managed by the World Bank to set up the first Climate Innovation Centre (CIC) in the world. It is housed in Strathmore and serves SMEs financially and technically to solve challenges posed by the adverse impact of climate change either by mitigation or adaptation.

In 2013, he was honored by the Brazilian Government with the title of “Comendador da Ordem do Rio Branco” for his services towards education and poverty alleviation in Africa. Professor Da Silva is the first elected president and founding member of the Association of Energy Professionals (EA) and the current chairman of the KCIC board of directors.

---

## Associate Editors

**Ayansina Ayanlade** Department of Geography, Obafemi Awolowo University, Ile-Ife, Nigeria

**Sebastiao Famba** Land and Water Use, Faculty of Agronomy and Forestry Engineering, University Eduardo Mondlane, Maputo, Mozambique

**Afusat Jagun Jubril** University of Ibadan, Ibadan, Nigeria

**C. V. Nnamani** Plant Systematics and Conservation Biology Research Unit, Department of Applied Biology, Faculty of Science, Ebonyi State University, Abakaliki, Nigeria

**Olukunle Olaonipekun Oladapo** Department of Science Laboratory Technology, Ladoko Akintola University of Technology, Ogbomoso, Nigeria

**Edmond Totin** Universite Nationale d'Agriculture (Benin), Ketou, Benin

**Habtamu Taddele Menghistu** Department of Basic and Diagnostic Sciences Mekelle University, College of Veterinary Sciences Mekelle, Tigray, Ethiopia

Mekelle University, Institute of Climate and Society Mekelle, Tigray, Ethiopia

Department of Agricultural and Resource Economics Mekelle University, College of Dryland Agriculture and Natural Resources Mekelle, Tigray, Ethiopia

**Everisto Mapedza** International Water Management Institute (IWMI), Accra, Ghana

**Nsikak-Abasi Aniefiok Etim** University of Uyo, Uyo, Nigeria

**Artie Ng** Research Centre for Green Energy, Transport and Building, Hong Kong Polytechnic University, Hung Hom, Hong Kong

Waterloo Institute for Sustainable Energy, University of Waterloo, Waterloo, Canada

**Hamisai Hamandawana** Department of Geographical Information Systems (GIS) and Remote Sensing, University of Fort Hare, Alice, South Africa

---

## Reviewers

**Adolphine Kateka** Global water partnership, South Africa, Tanzania

**Agele Samuel** Federal University of Technology, Akure, Nigeria

**Andriamahazo Michelle** Ministry of Agriculture, Livestock and Fisheries, Antananarivo, Madagascar

**Aubin Nzaou** University of Houston Law Center, Energy and Natural Resources (EENR) Center, Houston, USA

**Ayodeji Oluleye** Federal University of Technology, Akure, Nigeria

**Bertha Othoche** Pwani University, Kilifi County, Kenya

**Boaventura Cuamba** Eduardo Mondlane University, Energy Research Centre, Maputo, Mozambique

**Brent Jacobs** University of Technology Sydney, Institute for Sustainable Futures, Ultimo, NSW, Australia

**Brigida Rocha Brito** Universidade Autónoma de Lisboa, International Relations (Environmental Studies and International Cooperation), Lisbon, Portugal

**Caroline Mulinya** Kaimosi Friends University, Kaimosi, Kenya

**Chunlan Li** East China Normal University, School of Geographic Sciences, Shanghai, China

**Daniel M. Nzengya** St Paul's University, Limuru, Kenya

**Daniel Tadesse** University of Gondar, Gondar, Ethiopia

**David Ellison** Swedish University of Agricultural Sciences and University of Bern, Forest Resource Management, Baar, Switzerland

**Ellen Kalmbach** Brot für die Welt, Africa and Asia-Pacific, Berlin, Germany

**Hussein Sulieman** University of Gadarif, El-Gadarif, Sudan

**Isaac B. Oluwatayo** University of Venda, Agricultural Economics and Agribusiness, Thohoyandou, Limpopo province, South Africa

**Jamal Alibou** Hassania High School of Public Works for Engineers, Department of Hydraulic, Environment and Climate, Casablanca, Maroc

**Jean-Luc Kouassi** Felix Houphouet-Boigny Polytechnic Institute (INP-HB), Abidjan, Côte d'Ivoire

**Jokastah Wanzuu Kalung** South Eastern Kenya University, Nairobi, Kenya

**Jonathan Casey** CABI (Centre for Agriculture and Bioscience International), Wallingford, UK

**Jyotsana Shukla** Amity Institute of Behavioral and Allied Sciences, Lucknow, India

**Lawrence Olusola Oparinde** The Federal University of Technology, Department of Agricultural and Resource Economics, Akure, Ondo State, Nigeria

**Matthew Chidozie Ogwu** University of Benin, Benin, Nigeria  
Università di Camerino – Centro Ricerche Floristiche dell'Appennino, Parco Nazionale del Gran Sasso e Monti della Laga, Barisciano (L'Aquila), Italy

**Menas Wuta** University of Zimbabwe, Harare, Zimbabwe

**Michael Robert Nkuba** Department of Environmental sciences, University of Botswana, Gaborone, Botswana

**Nelson Chanza** Department of Geography, Bindura University of Science Education, Bindura, Zimbabwe

**Norbert F. Tchouaffe Tchiadje** Pan African Institute for Development, Engineering Science, Yaounde, Cameroon

**Olaniran Anthony Thompson** The Federal University of Technology, Akure, Nigeria

**Olawale Emmanuel Olayide** University of Ibadan, Centre for Sustainable Development, Ibadan, Nigeria

**Olga Laiza Kupika** Chinhoyi University of Technology, School of Wildlife Ecology and Conservation, Harare, Zimbabwe

**Olufemi Samson Adesina** World Hunger Fighters Foundation, Ibadan, Oyo, Nigeria

**Oluwabunmi Opeyemi Adejumo** Obafemi Awolowo University, Institute for Entrepreneurship and Development Studies, Ile-Ife, Nigeria

**Oyeshola Kofoworola** Joint Research Centre, Seville, Spain

**Pantaleo Munishi** Sokoine University of Agriculture (SUA), Morogoro, Tanzania

---

**Peter J. Glynn** Bond University, Robina, Australia

**Russell Yost** University of Hawaii, Manoa, USA

**Sam Wong** University College Roosevelt (affiliated with Utrecht University), Middelburg, The Netherlands

**Sarah Cunha** LAQV-REQUIMTE, Porto, Portugal

**Zakaria Fouad Fawzy Hassan** National Research Centre, Agricultural and biological Research, Cairo, Egypt

**Zodwa Lihle Motsa** University of South Africa, Pretoria, South Africa

---

## Contributors

**Abdultaofeek Abayomi** Department of Information and Communication Technology, Mangosuthu University of Technology, Umlazi, Durban, South Africa

**T. A. Abdulbaki** Department of Agricultural Extension and Rural Development, Faculty of Agriculture, University of Ilorin, Ilorin, Nigeria

**Eucharia A. Abia** Integrated Health for All Foundation (IHAF), Yaounde, Cameroon

**Wilfred A. Abia** Laboratory of Pharmacology and Toxicology, Department of Biochemistry, Faculty of Science, University of Yaounde 1, Yaounde, Cameroon  
School of Agriculture, Environmental Sciences, and Risk Assessment, College of Science, Engineering and Technology (COSET), Institute for Management and Professional Training (IMPT), Yaounde, Cameroon  
Integrated Health for All Foundation (IHAF), Yaounde, Cameroon

**M. O. Abioja** Department of Animal Physiology, College of Animal Science and Livestock Production, Federal University of Agriculture, Abeokuta, Nigeria

**J. A. Abiona** Department of Animal Physiology, College of Animal Science and Livestock Production, Federal University of Agriculture, Abeokuta, Nigeria

**Toyin Abolade** Department of Agricultural Economics and Extension Faculty of Agriculture, Nnamdi Azikiwe University, Awka, Nigeria

**Salé Abou** National Advanced School of Engineering of Maroua (ENSPM), The University of Maroua, Maroua, Cameroon

**Oluyemi Bright Aboyewa** Department of Physics, College of Arts and Sciences, Creighton University, Omaha, NE, USA

**James Ijampy Adamu** Nigerian Meteorological Agency, Abuja, Nigeria

**Akintayo Adedoyin** Department of Physics, Faculty of Science, University of Botswana, Gaborone, Botswana

**Abiodun Adeeko** Federal College of Agriculture, Agricultural Extension and Management, Akure, Ondo State, Nigeria

**E. Adesanya Adefisan** Department of Meteorology and Climate Science, Federal University of Technology, Akure, Nigeria

**Olufolake Adelakun** Department of Agricultural Extension and Rural Development, University of Ibadan, Ibadan, Nigeria

**Lydia Adeleke** Department of Fisheries and Aquaculture Technology, Federal University of Technology, Akure, Nigeria

**M. L. Adeleke** Department of Fisheries and Aquaculture Technology, The Federal University of Technology, Akure, Akure, Nigeria

**Oluwaseun Adeleke** Department of Agricultural Extension and Rural Development, University of Ibadan, Ibadan, Nigeria

**T. D. Adepoju** Department of Chemical Engineering, Obafemi Awolowo University, Ile-Ife, Nigeria

**S. A. Aderinoye-Abdulwahab** Department of Agricultural Extension and Rural Development, Faculty of Agriculture, University of Ilorin, Ilorin, Nigeria

**Francis Adesina** Department of Geography, Obafemi Awolowo University, Ile-Ife, Nigeria

**D. B. Adewale** Department of Crop Science and Horticulture, Federal University Oye-Ekiti, Ikole-Ekiti, Nigeria

**Z. Debo Adeyewa** Department of Meteorology and Climate Science, Federal University of Technology, Akure, Nigeria

**Prosper Adiku** Institute for Environment and Sanitation Studies, College of Basic and Applied Sciences, University of Ghana, Accra, Ghana

**Samuel Godfried Kwasi Adiku** Department of Soil Science, University of Ghana, Legon, Ghana

**Michael O. Adu** Department of Crop Science, University of Cape Coast, Cape Coast, Ghana

**Oluwatosin Benedict Adu** Department of Biochemistry, Lagos State University, Lagos, Nigeria

**Damilola T. Agbalajobi** Department of Political Science, Obafemi Awolowo University, Ile-Ife, Nigeria

**Ali Agoumi** Laboratory of Civil Engineering, Hydraulic, Environment and Climate Change, Hassania School of Public Works, Casablanca, Morocco

**Abdellatif Ahbari** Laboratory of Process Engineering and Environment, Faculty of Sciences and Techniques, Hassan II University of Casablanca, Mohammedia, Morocco

**Benjamin Ahmed** Department of Agricultural Economics, ABU, Zaria, Nigeria

**Abel Ehimen Airoboman** Department of Electrical/Electronic Engineering, Nigerian Defence Academy, Kaduna, Nigeria

**Felix Ayemere Airoboman** Faculty of Arts, Department of Philosophy, University of Benin, Benin City, Nigeria

**Patience Ose Airoboman** Department of Biotechnology, Nigerian Defence Academy, Kaduna, Nigeria

**Sunday Adesola Ajayi** Department of Crop Production and Protection, Obafemi Awolowo University, Ile-Ife, Nigeria

Institute for Sustainable Development, First Technical University, Ibadan, Nigeria

**Vincent O. Ajayi** West African Science Service Center on Climate Change and Adapted Land Use, Federal University of Technology, Akure, Ondo State, Nigeria  
Department of Meteorology and Climate Science, Federal University of Technology, Akure, Nigeria

**Igbekele Amos Ajibefun** Department of Agricultural Economics and Rural Sociology, Auburn University, Auburn, AL, USA

**Caroline Fadeke Ajilogba** Division of Agrometeorology, Agricultural Research Council – Soil, Climate and Water, Pretoria, South Africa

**Doris Akachukwu** Department of Agriculture, Health and Environment, Natural Resources Institute, University of Greenwich, Chatham, UK

**Ugbah Paul Akeh** National Weather Forecasting and Climate Research Centre, Nigerian Meteorological Agency, Abuja, Nigeria

**C. A. O. Akinbami** Institute for Entrepreneurship and Development Studies, Obafemi Awolowo University, Ile Ife, Osun State, Nigeria

**Oluwole Matthew Akinnagbe** Department of Agricultural Extension and Communication Technology, School of Agriculture and Agricultural Technology, Federal University of Technology, Akure, Nigeria

**Eric A. Alamou** Laboratory of Applied Hydrology (LHA), National Institute of Water (NIW), Cotonou, Bénin

**Rahinatu Sidiki Alare** Faculty of Earth and Environmental Sciences, Department of Environmental Sciences, C.K. Tedam University of Technology and Applied Sciences, Navrongo, Ghana

**Arragaw Alemayehu** Department of Geography and Environmental Studies, Debre Berhan University, Debre Berhan, Ethiopia



**Madi Ali** National Advanced School of Engineering of Maroua (ENSPM), The University of Maroua, Maroua, Cameroon

**D. Al-Kenawy** WorldFish, Abbassa, Abou-Hammad, Sharkia, Egypt

**Ibrahim Alkoiret Traoré** Laboratoire d'Ecologie, Santé et Production Animales (LESPA), Faculté d'Agronomie, Université de Parakou, Parakou, République du Bénin

**Rasheedat Alliagbor** Department of Agricultural and Resource Economics, Federal University of Technology Akure, Akure, Ondo, Nigeria

**Becky Nancy Aloo** Department of Sustainable Agriculture and Biodiversity Conservation, Nelson Mandela African Institution of Science and Technology, Arusha, Tanzania

Department of Biological Sciences, University of Eldoret, Eldoret, Kenya

**Zakou Amadou** Faculty of Agricultural Sciences, Department of Rural Economics and Sociology, Tahoua University, Tahoua, Niger

**Teshale W. Amanuel** Wondo Genet College of Forestry and Natural Resource, Hawassa University, Hawassa, Ethiopia

**Williette E. Amba** School of Agriculture, Environmental Sciences, and Risk Assessment, College of Science, Engineering and Technology (COSET), Institute for Management and Professional Training (IMPT), Yaounde, Cameroon

**Chiara Ambrosino** Plan International UK, London, UK

**Leonard Kofitse Amekudzi** Department of Physics, Kwame Nkrumah University of Science and Technology, Kumasi, Ghana

**Vincent Amelie** Seychelles Meteorological Authority (SMA), Mahé, Seychelles

**Oseni Taiwo Amoo** Risk and Vulnerability Science Centre, Walter Sisulu University, Eastern Cape, South Africa

**Ajibefun Igbekele Amos** Department of Agricultural and Resource Economics, Federal University of Technology, Akure (FUTA), Akure, Nigeria

**Athanasius Fonteh Amungwa** Department of Sociology and Anthropology, Faculty of Social and Management Sciences, University of Buea, Buea, Cameroon

**Divine Odame Appiah** Environmental Management Practice Research Unit, Department of Geography and Rural Development, Faculty of Social Sciences, Kwame Nkrumah University of Science and Technology, Kumasi, Ghana

**Shri Dewi Applanaidu** Department of Economics and Agribusiness, School of Economics, Finance and Banking, College of Business, Universiti Utara Malaysia, Sintok, Malaysia

**E. F. Aransiola** Department of Chemical Engineering, Obafemi Awolowo University, Ile-Ife, Nigeria

**Abraham Adewale Aremu** Department of Physics with Electronics, Dominion University, Ibadan, Oyo, Nigeria

**Frederick A. Armah** Department of Environmental Science, University of Cape Coast, Cape Coast, Ghana

**D. J. Arotupin** Department of Microbiology, Federal University of Technology, Akure, Nigeria

**Paul A. Asare** Department of Crop Science, University of Cape Coast, Cape Coast, Ghana

**Peter Asare-Nuamah** Institute of Governance, Humanities and Social Science, Pan African University, Soa, Cameroon

School of Sustainable Development, University of Environment and Sustainable Development, Somanya, Eastern Region, Ghana

**Shilpa Muliyl Asokan** Climate Change and Sustainable Development, The Nordic Africa Institute, Uppsala, Sweden

**Alassan Seidou Assani** Laboratoire d'Ecologie, Santé et Production Animales (LESPA), Faculté d'Agronomie, Université de Parakou, Parakou, République du Bénin

**Godwin Atai** Department of Geography, Obafemi Awolowo University, Ile-Ife, Nigeria

**Christopher John Atkinson** Natural Resources Institute, University of Greenwich, London, UK

Department of Agriculture, Health and Environment, Natural Resources Institute, University of Greenwich, Chatham, UK

**Nyong Princely Awazi** Department of Forestry, Faculty of Agronomy and Agricultural Sciences, University of Dschang, Dschang, Cameroon

**David Olufemi Awolala** African Climate Change Leadership Program (AfriCLP), University of Nairobi, Kenya and Institute of Resource Assessment, University of Dar es salaam, Dar es Salaam, Tanzania

**Desalegn Ayal** Center for Food Security Studies, College of Development Studies, Addis Ababa University, Addis Ababa, Ethiopia

**Ayansina Ayanlade** Department of Geography, Obafemi Awolowo University, Ile-Ife, Nigeria

**Taiwo B. Ayinde** Samaru College of Agriculture, Division of Agricultural Colleges, Ahmadu Bello University (ABU), Zaria, Nigeria

**Mohamed Nasser Baco** Laboratoire Société-Environnement (LaSen), Faculté d'Agronomie, Université de Parakou, Parakou, République du Bénin

**R. Ayodeji Balogun** Department of Meteorology and Climate Science, Federal University of Technology, Akure, Nigeria

**Aliyu Barau** Department of Urban and Regional Planning, Bayero University Kano, Kano, Nigeria

**Till Bärnighausen** Heidelberg Institute of Global Health (HIGH), Heidelberg University, Heidelberg, Germany

Department of Global Health and Population, Harvard T. H. Chan School of Public Health, Boston, MA, USA

Africa Health Research Institute (AHRI), Durban/Mtubatuba, South Africa

**Johan Bastiaensen** Institute of Development Policy (IOB), University of Antwerp, Antwerp, Belgium

**Nnyaladzi Batisani** Botswana Institute for Technology Research and Innovation, Gaborone, Botswana

Food and Agriculture Organization of the United Nations, Rome, Italy

**Utlwang Batlang** Botswana University of Agriculture and Natural Resources, Gaborone, Botswana

**Barasa Bernard** Institute of Environment and Natural Resources, Makerere University, Kampala, Uganda

**Jim Bingen** Michigan State University (MSU), East Lansing, MI, USA

**Daniele Bricca** Sapienza University of Rome, Rome, Italy

**Cecile Brugere** Soulfish Research and Consultancy, York, UK

**Barbara Nakangu Bugembe** International Union for Conservation of Nature – IUCN, Gland, Switzerland

**Aditi Bunker** Heidelberg Institute of Global Health (HIGH), Heidelberg University, Heidelberg, Germany

**Roelof P. Burger** Unit for Environmental Sciences and Management, North-West University, Potchefstroom, South Africa

**Raban Chanda** Department of Environmental Sciences, Faculty of Science University of Botswana, Gaborone, Botswana

**Nelson Chanza** Department of Geography, Bindura University of Science Education, Bindura, Zimbabwe

**Martin Munashe Chari** Department of Geography and Environmental Science, University of Fort Hare, Alice, South Africa

Risk and Vulnerability Science Centre (RVSC), University of Fort Hare, Alice, South Africa

**Paolo Cherubini** DESTEC, University of Pisa, Pisa, Italy

**David O. Chiawo** Strathmore University, Nairobi, Kenya

**Dumisani Chirambo** Seeds of Opportunity, Blantyre, Malawi

**Innocent Chirisa** Department of Demography Settlement and Development, University of Zimbabwe, Harare, Zimbabwe

Department of Urban and Regional Planning, University of the Free State, Bloemfontein, South Africa

**Kennedy Choongo** Fiji National University, College of Agriculture, Fisheries and Forestry, Suva, Fiji

School of Veterinary Medicine, University of Zambia, Lusaka, Zambia

**Dirk P. Cilliers** Unit for Environmental Sciences and Management, North-West University, Potchefstroom, South Africa

**Aida Cuni-Sanchez** York Institute for Tropical Ecosystems, Department of Environment and Geography, University of York, York, North Yorkshire, UK

**Izael da Silva** Strathmore University, Nairobi, Kenya

**Alima Dajuma** Department of Meteorology and Climate Sciences, West African Science Service Centre on Climate Change and Adapted Land Use (WASCAL), Federal University of Technology Akure (FUTA), Ondo State, Nigeria

Laboratoire de Physique de l'Atmosphère et de Mécaniques des Fluides (LAPA-MF), Université Félix Houphouët-Boigny, Abidjan, Côte d'Ivoire

**Peter Dambach** Heidelberg Institute of Global Health (HIGH), Heidelberg University, Heidelberg, Germany

**Abubakar Hamid Danlami** Department of Economics, Faculty of Social Sciences, Bayero University Kano, Kano, Nigeria

**Jones Abrefa Danquah** Department of Geography and Regional Planning, Faculty of Social Sciences, College of Humanities and Legal Studies, University of Cape Coast, Cape Coast, Ghana

**Eric Yirenyi Danquah** West Africa Centre for Crop Improvement, University of Ghana, College of Basic and Applied Sciences, Accra, Ghana

**Ina Danquah** Heidelberg Institute of Global Health (HIGH), Heidelberg University, Heidelberg, Germany

German Institute of Human Nutrition Potsdam-Rehbruecke (DIfE), Nuthetal, Germany

**Eugene Tenkorang Darko** Geography and Resource Development, University of Ghana, Legon, Ghana

**K. Sian Davies-Vollum** Environmental Sustainability Research Centre, University of Derby, Derby, UK

**Michael Dede** Chicoco Collective, Port Harcourt, Nigeria

**Olanike F. Deji** Obafemi Awolowo University, Ile Ife, Nigeria

**M. Dickson** WorldFish, Abbassa, Abou-Hammad, Sharkia, Egypt

**Arona Diedhiou** Laboratoire de Physique de l'Atmosphère et de Mécaniques des Fluides (LAPA-MF), Université Félix Houphouët-Boigny, Abidjan, Côte d'Ivoire  
Université Grenoble Alpes, IRD, Grenoble INP, IGE, Grenoble, France

**Senyo Dotsey** Urban Studies and Regional Science, Gran Sasso Science Institute, L'Aquila, Italy

**Jimmy Dudhia** Mesoscale and Microscale Meteorology Laboratory, National Center for Atmospheric Research, Foothills Laboratory, Boulder, CO, USA

**Hillary Dumba** Institute of Education, College of Education Studies, University of Cape Coast, Cape Coast, Ghana

**Eromose E. Ebhuoma** College of Agriculture and Environmental Sciences, Department of Environmental Sciences, University of South Africa (UNISA), Johannesburg, South Africa

**Moses Egaru** International Union for Conservation of Nature – IUCN, Gland, Switzerland

**Jemimah Timothy Ekanem** Department of Agricultural Economics and Extension, Faculty of Agriculture, Akwa Ibom State University, Uyo, Nigeria

**John Saviour Yaw Eleblu** West Africa Centre for Crop Improvement, University of Ghana, College of Basic and Applied Sciences, Accra, Ghana

**Mark Ellis-Jones** GreenFi Systems Ltd, Dublin, Ireland

**Philip Olanrewaju Eniola** Department of Agricultural Technology, The Oke-Ogun Polytechnic, Saki, Oyo State, Nigeria

**Saeid Eslamian** Department of Water Engineering, College of Agriculture, Center of Excellence on Risk Management and Natural Hazards, Isfahan University of Technology, Isfahan, Iran

**Daniel Etongo** James Michel Blue Economy Research Institute, University of Seychelles, Victoria, Seychelles

**Henri-Count Evans** School of Applied Human Sciences, Centre for Communication, Media and Society, University of Kwazulu-Natal, Durban, South Africa

**Olushola Fadairo** Department of Agricultural Extension and Rural Development, University of Ibadan, Ibadan, Nigeria

**Oluwatosin Oluwasegun Fasina** School of Agriculture and Agricultural Technology, Federal University of Technology, Akure, Akure, Nigeria

**B. E. Fawole** Department of Agricultural Extension and Rural Development, Federal University, Dutsinma, Nigeria

**Walter Leal Filho** Research and Transfer Centre “Sustainable Development and Climate Change Management” Hamburg University of Applied Sciences Hamburg, Germany

**Davide Fioriti** DESTEC, University of Pisa, Pisa, Italy

**Joseph Francis** Institute for Rural Development, University of Venda, Thohoyandou, South Africa

**Bernhard Freyer** Division of Organic Farming, University of Natural Resources and Life Sciences (BOKU), Vienna, Austria

**M. Gatheru** Kenya Agricultural and Livestock Research Organization (KALRO), Katumani, Kenya

**Michael Adedapo Gbadegesin** Department of Biochemistry, Faculty of Basic Medical Sciences, University of Ibadan, Ibadan, Oyo State, Nigeria

**Imoleayo E. Gbode** West African Science Service Center on Climate Change and Adapted Land Use, Federal University of Technology, Akure, Ondo State, Nigeria  
Mesoscale and Microscale Meteorology Laboratory, National Center for Atmospheric Research, Foothills Laboratory, Boulder, CO, USA

**S. R. Ghimire** The Biosciences Eastern and Central Africa – International Livestock Research Institute (BecA-ILRI) Hub, Nairobi, Kenya

**Getrude Gichuhi** Department of Research and Innovation, Strathmore University, Nairobi, Kenya

**Stephen Gitahi** Department of Research and Innovation, Strathmore University, Nairobi, Kenya

**George Gitau** Faculty of Veterinary Medicine, University of Nairobi, Nairobi, Kenya

**C. M. Githunguri** Kenya Agricultural and Livestock Research Organization (KALRO) Food Crops Research Centre Kabete, Nairobi, Kenya

**Julie Greenwalt** Go Green for Climate, Amsterdam, Netherlands

**Arthur Gwagwa** CIPIT, Strathmore University, Nairobi, Kenya

**Joseph P. Gweyi-Onyango** Department of Agricultural Science and Technology, Kenyatta University, Nairobi, Kenya

**Hamisai Hamandawana** Department of Geographical Information Systems (GIS) and Remote Sensing, University of Fort Hare, Alice, South Africa

**T. B. Hammed** Department of Environmental Health Sciences, Faculty of Public Health, College of Medicine, University of Ibadan, Ibadan, Nigeria

**Mayday Haulofu** Water Quality Research, SANUMARC, Sam Nujoma Campus, University of Namibia, Henties Bay, Namibia

**Martha K. Hausiku** Mushroom Research, SANUMARC, Sam Nujoma Campus, University of Namibia, Henties Bay, Namibia

**Fabien C. C. Hountondji** Faculté d'Agronomie, University of Parakou, Parakou, Benin

**Ben Hufton** Plan International UK, London, UK

**Michael F. Hutchinson** Fenner School of Environment and Society, Australian National University, Canberra, ACT, Australia

**S. A. Idowu** Department of Microbiology, Federal University of Technology, Akure, Nigeria

**Yaya Idrissou** Laboratoire d'Ecologie, Santé et Production Animales (LESPA), Faculté d'Agronomie, Université de Parakou, Parakou, République du Bénin

**Oluwatobi Ololade Ife-Adediran** Geochronology Division, CSIR-National Geophysical Research Institute (NGRI), Hyderabad, India

Department of Physics, Federal University of Technology Akure, Akure, Ondo State, Nigeria

**George Olanrewaju Ige** Department of Agricultural Extension and Communication Technology, School of Agriculture and Agricultural Technology, Federal University of Technology, Akure, Nigeria

**Paul Iji** Fiji National University, College of Agriculture, Fisheries and Forestry, Suva, Fiji

**Uche Dickson Ijioma** Department of Raw Material and Natural Resource Management, Brandenburg University of Technology Cottbus-Senftenberg, Cottbus, Germany

**Oluwatosin Omowunmi Ishola** Federal College of Agriculture, Agricultural Extension and Management, Akure, Ondo State, Nigeria

**Adetunji Oroye Iyiola-Tunji** National Agricultural Extension and Research Liaison Services, Ahmadu Bello University, Zaria, Nigeria

**Joyce Jefwa** Botany Department, National Museums of Kenya, Nairobi, Kenya

**Anne Jerneck** Lund University Centre for Sustainability Studies, Lund, Sweden

**Jacob Victor Jerry** Department of Fisheries and Aquaculture Technology, Federal University of Technology, Akure (FUTA), Akure, Nigeria

**Aisha Jjagwe** Department of Geoscience, Nelson Mandela University, Port Elizabeth, South Africa

**Paul Apagu John** Department of Animal Science, Ahmadu Bello University, Zaria, Nigeria

**Ibinabo Johnson** Chicoco Collective, Port Harcourt, Nigeria

**Georgia de Jong Cleyndert** York Institute for Tropical Ecosystems, Department of Environment and Geography, University of York, York, North Yorkshire, UK

**Vincent Kakembo** Department of Geoscience, Nelson Mandela University, Port Elizabeth, South Africa

**Felix Kanungwe Kalaba** School of Natural Resources, Copperbelt University, Kitwe, Zambia

**Dorcas Kalele** Institute for Climate Change and Adaptation (ICCA), University of Nairobi, Nairobi, Kenya

**David Karienyé** Department of Geography, Garissa University, Garissa, Kenya

**Caroline Wanjiru Kariuki** Strathmore Institute of Mathematical Sciences, Nairobi, Kenya

**Alice Nyawira Karuri** School of Humanities and Social Sciences, Strathmore University, Nairobi, Kenya

**Edward Kato** International Food Policy and Research Institute, Washington, DC, USA

**Floney P. Kawaye** Fenner School of Environment and Society, Australian National University, Canberra, ACT, Australia

**Miftah F. Kedir** WGCNFR, Hawassa University, Shashemene, Ethiopia  
Central Ethiopia Environment and Forest Research Center, Addis Ababa, Ethiopia

**Sizwile Khoza** Unit for Environmental Sciences and Management, African Centre for Disaster Studies, North-West University, Potchefstroom, South Africa

**Michael Kisangari** Centre of Excellence in Information Technology (CENIT@EA), Arusha, Tanzania

**Nana A. B. Klutse** Ghana Space Science and Technology Institute, Atomic Energy Commission, Accra, Ghana

**Daniel Koomson** Environmental Sustainability Research Centre, University of Derby, Derby, UK



**Dumisani Shoko Kori** Institute for Rural Development, University of Venda, Thohoyandou, South Africa

**Sophie Kutegeka** International Union for Conservation of Nature – IUCN, Gland, Switzerland

**Brian Felix Kwena** Kenya Water for Health Organization, Nairobi, Kenya

**David Lagat** Construction Research and Business Development Department, National Construction Authority, Nairobi, Kenya

**Isaac Larbi** Climate Change and Water Resources, West African Science Service Centre on Climate Change and Adapted Land Use (WASCAL), Université d'Abomey-Calavi, Cotonou, Benin

School of Sustainable Development, University of Environment and Sustainable Development, Somanya, Ghana

Department of Civil Engineering, Faculty of Engineering, Koforidua Technical University, Koforidua, Ghana

**Peter Okidi Lating** Department of Electrical and Computer Engineering, Makerere University, Kampala, Uganda

**Kamoru A. Lawal** National Weather Forecasting and Climate Research Centre, Nigerian Meteorological Agency, Abuja, Nigeria

African Climate and Development Initiative, University of Cape Town, Cape Town, South Africa

**Emmanuel A. Lawin** Laboratory of Applied Hydrology (LHA), National Institute of Water (NIW), Cotonou, Bénin

**David Lesolle** Department of Environmental Sciences, Faculty of Science University of Botswana, Gaborone, Botswana

**Yinpeng Li** International Global Change Institute and CLIMsystems Ltd, Hamilton, New Zealand

**Ondari Lilian** ClayCo, Chicago, IL, USA

**Gadaffi M. Liswaniso** Mariculture Research, SANUMARC, Sam Nujoma Campus, University of Namibia, Henties Bay, Namibia

**Changhai Liu** Research Applications Laboratory, National Center for Atmospheric Research, Foothills Laboratory, Boulder, CO, USA

**Cush Ngonzo Luwesi** University of Kwango, Kenge, Democratic Republic of Congo

**Dilys Sefakor MacCarthy** Soil and Irrigation Research Centre Kpong, University of Ghana, Accra, Ghana

**Joseph Macharia** Department of Geography, Kenyatta University, Nairobi, Kenya

**Samuel K. Mafwila** Oceanography Research, SANUMARC, Sam Nujoma Campus, University of Namibia, Henties Bay, Namibia

Department of Fisheries and Aquatic Science, Sam Nujoma Campus, University of Namibia, Henties Bay, Namibia

**Royford Magiri** Fiji National University, College of Agriculture, Fisheries and Forestry, Suva, Fiji

**John Kibe Maguta** Faculty of Social Science, St Paul's University, Limuru, Kenya

**Paul Maina Mwari** Faculty of Social Sciences, St Paul's University, Limuru, Kenya

**Billy Amendi Makumba** Department of Biological Sciences, Moi University, Eldoret, Kenya

**Majoumo Christelle Malyse** Department of Geography, University of Dschang, Dschang, Cameroon

**Anri Manderson** Hoedspruit Hub, Hoedspruit, South Africa

**R. Mandumbu** Crop Science Department, Bindura University of Science Education, Bindura, Zimbabwe

**Margaret Najjingo Mangheni** Department of Extension and Innovation Studies, College of Agricultural and Environmental Sciences, Makerere University Kampala, Kampala, Uganda

**Isabel Mank** Heidelberg Institute of Global Health (HIGH), Heidelberg University, Heidelberg, Germany

**Hilda Manzi** Department of Agricultural Science and Technology, Kenyatta University, Nairobi, Kenya

**Benjamin Mapani** Faculty of Engineering, Department of Mining and Process Engineering, Namibia University of Science and Technology, Windhoek, Namibia

**Isaac Mapaire** Faculty of Science, Department of Biological Sciences, University of Namibia, Windhoek, Namibia

**Robert Marchant** York Institute for Tropical Ecosystems, Department of Environment and Geography, University of York, York, North Yorkshire, UK

**Senny Masike** International Global Change Institute and CLIMsystems Ltd, Hamilton, New Zealand

**Abraham R. Matamanda** Department of Urban and Regional Planning, University of the Free State, Bloemfontein, South Africa

**Newton R. Matandirotya** Unit for Environmental Sciences and Management, North-West University, Potchefstroom, South Africa

**Anthony Njuguna Matheri** Department of Chemical Engineering, University of Johannesburg, Johannesburg, South Africa

**Federica Matteoli** Food and Agriculture Organization of the United Nations, Rome, Italy

**Josephine Mbandi** School of Computational and Communication Sciences and Engineering (CoCSE), Nelson Mandela Institution of Science and Technology (NM-AIST), Tengeru, Arusha, Tanzania

**Ernest Rashid Mbega** Department of Sustainable Agriculture and Biodiversity Conservation, Nelson Mandela African Institution of Science and Technology, Arusha, Tanzania

**Mohamed Meddi** Ecole Nationale Supérieure d'Hydraulique de BLIDA, Boufarik, Algeria

**Nkiru Theresa Meludu** Department of Agricultural Economics and Extension Faculty of Agriculture, Nnamdi Azikiwe University, Awka, Nigeria

**Abdelhamid Mezrhah** Laboratory Communication, Education, Digital Usage and Creativity, ETIGGE Research Team, Bd. Mohammed VI, University Complex, Mohammed Premier Oujda University, Oujda, Morocco

**Andrea Micangeli** DIMA, Sapienza University of Rome, Rome, Italy

**Gagoitseope Mmopelwa** Department of Environmental Sciences, Faculty of Science University of Botswana, Gaborone, Botswana

**Ahmed Mohamed** Garissa University, Garissa, Kenya

**Belaïd Mohamed** Department of Chemical Engineering, University of Johannesburg, Johannesburg, South Africa

**A. S. Momodu** Centre for Energy Research and Development, Obafemi Awolowo University, Ile-Ife, Nigeria

**Lilian Motaroki** International Centre of Insect Physiology and Ecology (ICIPE), Nairobi, Kenya

**M. R. Motsholapheko** Water Resources Management Program, Okavango Research Institute, University of Botswana, Maun, Botswana

**Philani Moyo** Fort Hare Institute of Social and Economic Research (FHISER), University of Fort Hare, East London, South Africa

**Moreblessings Mpofo** Department of Development Studies, Faculty of Humanities and Social Sciences, Lupane State University, Bulawayo, Zimbabwe

**Caroline Mubekaphi** School of Agricultural, Earth and Environmental Sciences, University of KwaZulu-Natal, Scottsville, South Africa

**Maxwell Mudhara** College of Agricultural, Engineering and Science, Discipline of Agricultural Economics, University of KwaZulu-Natal, Scottsville, Pietermaritzburg, South Africa

**Angeline Mujeyi** College of Agricultural, Engineering and Science, Discipline of Agricultural Economics, University of KwaZulu-Natal, Scottsville, Pietermaritzburg, South Africa

**Billy Billiard Mukamuri** Centre for Applied Social Sciences, University of Zimbabwe, Harare, Zimbabwe

**Olga Nekesa Mulama** Strathmore Institute of Mathematical Sciences, Nairobi, Kenya

**Mike Muller** Wits School of Governance, University of the Witwatersrand, Johannesburg, South Africa

**Jean Mulopo** School of Chemical and Metallurgical Engineering, Faculty of Engineering and Built Environment, University of the Witwatersrand, Johannesburg, South Africa

**Stephen Munga** Centre for Global Health Research (CGHR) at the Kenya Medical Research Institute (KEMRI), Kisumu, Kenya

**Edward M. Mungai** Strathmore University Business School, Nairobi, Kenya

**Idris Muniru** Department of Biomedical Engineering, Faculty of Engineering and Technology, University of Ilorin, Ilorin, Nigeria

**Hupenyu A. Mupambwa** Desert and Coastal Agriculture Research, Sam Nujoma Marine and Coastal Resources Research Centre (SANUMARC), Sam Nujoma Campus, University of Namibia, Henties Bay, Namibia

**Pedro Murad as** IDOM, Consulting, Engineering, Architecture SAU, Madrid, Spain

Urban and Territorial Planning Department, Universidad Polit cnica de Madrid. Escuela T cnica Superior de Arquitectura, Madrid, Spain

**Aansbert Musimba** Faculty of Science, Department of Biological Sciences, University of Namibia, Windhoek, Namibia

**Tafadzwa Mutambisi** Department of Demography Settlement and Development, University of Zimbabwe, Harare, Zimbabwe

**Gamuchirai Mutezo** School of Chemical and Metallurgical Engineering, Faculty of Engineering and Built Environment, University of the Witwatersrand, Johannesburg, South Africa

**Chrocosciscus Mutisya** Department of Social Sciences, St Paul's University, Limuru, Kenya

**Kaampwe Muzandu** School of Veterinary Medicine, University of Zambia, Lusaka, Zambia

**Mabvuto Mwanza** Department of Electrical and Electronic Engineering, School of Engineering, University of Zambia, Lusaka, Zambia

**Saumu Ibrahim Mwashu** School of Geography, Geology and the Environment, Keele University, Staffordshire, UK

**Evelyne Touré N'Datchoh** Laboratoire de Physique de l'Atmosphère et de Mécaniques des Fluides (LAPA-MF), Université Félix Houphouët-Boigny, Abidjan, Côte d'Ivoire

**Andreas S. Namwoonde** Renewable Energy Research, SANUMARC, Sam Nujoma Campus, University of Namibia, Henties Bay, Namibia

**A. M. Nasr-Allah** WorldFish, Abbassa, Abou-Hammad, Sharkia, Egypt

**Elinah Nciizah** Department of Development Studies, Zvishavane Campus, Midlands State University, Zvishavane, Zimbabwe

**Adornis D. Nciizah** Soil Science, Agricultural Research Council – Institute for Soil, Climate and Water, Pretoria, South Africa

**Tendai Nciizah** Department of Sociology, Rhodes University, Makhanda, South Africa

**Roseline Ncube** Faculty of Gender and Women Studies, Women's University in Africa, Harare, Zimbabwe

**Tharcisse Ndayizigiye** SMHI/Swedish Meteorological and Hydrological Institute, Nairobi, Kenya

**Ronald Boniphace Ndesanjo** Institute of Development Studies, University of Dar es Salaam, Dar es Salaam, Tanzania

**S. Wagura Ndiritu** Strathmore University Business School, Nairobi, Kenya

**Sibonokuhle Ndlovu** Department of Development Studies, Faculty of Humanities and Social Sciences, Lupane State University, Bulawayo, Zimbabwe

**Livhuwani Nemaconde** Unit for Environmental Sciences and Management, African Centre for Disaster Studies, North-West University, Potchefstroom, South Africa

**Rebecca Newman** York Institute for Tropical Ecosystems, Department of Environment and Geography, University of York, York, North Yorkshire, UK

**Julius Tata Nfor** Department of Geography, Planning and Environment, University of Dschang, Dschang, Cameroon

**Obadiah Ngigi** GreenFi Systems Ltd, Dublin, Ireland

**Jane Catherine Ngila** Department of Chemical Science, University of Johannesburg, Johannesburg, South Africa

Academic Affair, Riara University, Nairobi, Kenya

**Faith Ngum** Lilongwe, Malawi

**B. N. Ngwenya** Ecosystems Services Program, Okavango Research Institute, University of Botswana, Maun, Botswana

**Kareen L. Niba** School of Agriculture, Environmental Sciences, and Risk Assessment, College of Science, Engineering and Technology (COSET), Institute for Management and Professional Training (IMPT), Yaounde, Cameroon  
Integrated Health for All Foundation (IHAF), Yaounde, Cameroon

**Charles F. Nicholson** Nijmegen School of Management, Radboud University, Nijmegen, Netherlands

**Martin Reinhardt Nielsen** Department of Food and Resource Economics, Section for Global Development, University of Copenhagen, Copenhagen, Denmark

**D. M. G. Njarui** Kenya Agricultural and Livestock Research Organization (KALRO), Katumani, Kenya

**Chrocosciscus Njeru** Faculty of Social Sciences, St Paul's University, Limuru, Kenya

**E. N. Njiru** KALRO Katumani, Machakos, Kenya

**Michael Robert Nkuba** Department of Environmental Sciences, Faculty of Science University of Botswana, Gaborone, Botswana

**C. V. Nnamani** Plant Systematics and Conservation Biology Research Unit, Department of Applied Biology, Faculty of Science, Ebonyi State University, Abakaliki, Nigeria

**Prince Nosa** Chicoco Collective, Port Harcourt, Nigeria

**Mary Nthambi** Department of Environmental Economics, Brandenburg University of Technology Cottbus-Senftenberg, Cottbus, Germany

**Winnie Ntinyari** Department of Agricultural Science and Technology, Kenyatta University, Nairobi, Kenya

**Chinedum Uzoma Nwajiuba** Department of Agriculture (Agricultural Economics and Extension Programme), Alex Ekwueme Federal University Ndufu-Alike, Ikwo, Ebonyi, Nigeria

**Chinyere Augusta Nwajiuba** Educational Foundations, Alex Ekwueme Federal University Ndufu-Alike, Ikwo, Ebonyi, Nigeria

**Chukwudi Nwaogu** Department of Forest Protection and Entomology, Faculty of Forestry and Wood Sciences, Czech University of Life Sciences, Prague 6-Suchdol, Czech Republic

Department of Environmental Management, Federal University of Technology, Owerri, Nigeria

Department of Ecology, Faculty of Environmental Sciences, Czech University of Life Sciences, Prague 6-Suchbát, Czech Republic

**Louis Nyahunda** Department of Social Work, University of Limpopo, Polokwane, South Africa

**G. Nyamadzawo** Department of Environmental Science, Bindura University of Science Education, Bindura, Zimbabwe

**Clement Nyamekye** Department of Civil Engineering, Faculty of Engineering, Koforidua Technical University, Koforidua, Ghana

**Benson Okinyi Nyawade** Plan International Kenya, Nairobi, Kenya

**C. Nyawenze** Cotton Company of Zimbabwe, Harare, Zimbabwe

**Kefasi Nyikahadzoi** Centre for Applied Social Sciences, University of Zimbabwe, Harare, Zimbabwe

**Daniel M. Nzengya** Department of Social Sciences, St Paul's University, Limuru, Kenya

**Joy Obando** Department of Geography, Kenyatta University, Nairobi, Kenya

**Peter Bilson Obour** Department of Geography and Resource Development, University of Ghana, Legon, Ghana

**Olalekan Olamigoke Odefadehan** Department of Agricultural Extension and Communication Technology, School of Agriculture and Agricultural Technology, Federal University of Technology, Akure, Nigeria

**Godfrey Odongtoo** Department of Computer Engineering, Busitema University, Tororo, Uganda

Department of Information Technology, Makerere University, Kampala, Uganda

**Peter Rock Ebo Odoom** Climate Change and Water Resources, West African Science Service Centre on Climate Change and Adapted Land Use (WASCAL), Université d'Abomey-Calavi, Cotonou, Benin

**Opeyemi Peter Ogunbusuyi** Department of Agricultural and Resource Economics, School of Agriculture and Agricultural Technology, Federal University of Technology, Akure, Nigeria

**Kehinde O. Ogunjobi** Department of Meteorology and Climate Sciences, West African Science Service Centre on Climate Change and Adapted Land Use (WASCAL), Federal University of Technology Akure (FUTA), Ondo State, Nigeria  
Federal University of Technology Akure (FUTA), Ondo State, Nigeria

**Oluwaseun James Oguntuase** Zenith Bank PLC, Lagos, Nigeria

Centre for Environmental Studies and Sustainable Development, Lagos State University, Lagos, Nigeria

**Philip G. Oguntunde** Department of Agricultural and Environmental Engineering, Federal University of Technology, Akure, Nigeria

**Gertrude Ogwok** International Union for Conservation of Nature – IUCN, Gland, Switzerland

**Matthew Chidozie Ogwu** Department of Plant Biology and Biotechnology, Faculty of Life Sciences, University of Benin, Benin City, Edo State, Nigeria

Scuola di Bioscienze e Medicina Veterinaria, Università di Camerino – Centro Ricerche Floristiche dell’Appennino, Parco Nazionale del Gran Sasso e Monti della Laga, Barisciano (L’Aquila), Italy

**Philippa Chinyere Ojmelukwe** Department of Food Science and Technology, Michael Okpara University of Agriculture, Umudike, Abia State, Nigeria

**Hammed Olabode Ojugbele** Regional and Local Economic Development Initiative, University of KwaZulu-Natal, Westville, South Africa

**Irene Ojuok** National Technical specialist Environment and Climate Change, World Vision Kenya, Nairobi, Kenya

**Gloria C. Okafor** Department of Civil Engineering, Nigeria Maritime University, Delta–State, Nigeria

**Joachim Chukwuma Okafor** Department of Political Science, University of Nigeria, Nsukka, Nigeria

**Emmanuel Chilekwu Okogbue** School of Meteorology and Climate Science, Federal University of Technology, Akure, Akure, Nigeria

**I. D. Okunade** Department of Chemical Engineering, Obafemi Awolowo University, Ile-Ife, Nigeria

**Olukunle Olaonipekun Oladapo** Department of Science Laboratory Technology, Ladoko Akintola University of Technology, Ogbomoso, Nigeria

**S. O. Oladejo** Department of Remote Sensing and Geoscience Information System, Federal University of Technology, Akure, Nigeria

**Adeola A. Oladimeji** Department of Microbiology, University of Ibadan, Ibadan, Nigeria

**Samuel Olajuyigbe** Department of Forest Production and Products, University of Ibadan, Ibadan, Nigeria

**Olumide A. Olaniyan** National Weather Forecasting and Climate Research Centre, Nigerian Meteorological Agency, Abuja, Nigeria

**Olanrewaju Olaniyan** Department of Economics, University of Ibadan, Ibadan, Nigeria



**Idowu Ologeh** Department of Environmental Management and Toxicology, Lead City University, Ibadan, Nigeria

**Odd Einar Olsen** Department of Safety, Economics, and Planning, University of Stavanger, Stavanger, Norway

**Siji Olutegbe** Department of Agricultural Extension and Rural Development, University of Ibadan, Ibadan, Nigeria

**Oluwole Olutola** University of Johannesburg, Johannesburg, South Africa

**Isaac Ayo Oluwatimilehin** Department of Geography, Obafemi Awolowo University, Ile-Ife, Nigeria

**Akinola Joshua Oluwatobi** Department of Fisheries and Aquaculture Technology, Federal University of Technology, Akure (FUTA), Akure, Nigeria

**Melissa Omino** CIPIT, Strathmore University, Nairobi, Kenya

**Olatunde Micheal Oni** Department of Pure and Applied Physics, Ladoke Akintola University of Technology, Ogbomoso, Nigeria

**Comfort A. Onya** Natural Resources and Environmental Management, University of Buea, Buea, Cameroon

**Anthony Nwa Jesus Onyekuru** Resource and Environmental Policy Research Centre, Department of Agricultural Economics, University of Nigeria, Nsukka, Nigeria

**Robert Ugochukwu Onyeneke** Department of Agriculture (Agricultural Economics and Extension Programme), Alex Ekwueme Federal University Ndufu-Alike, Ikwo, Ebonyi, Nigeria

**Patience Ifeyinwa Opat** Department of Agricultural Economics, University of Nigeria, Nsukka, Nigeria

**Chinwe Philomina Oramah** Department of Safety, Economics, and Planning, University of Stavanger, Stavanger, Norway

**Erimma Gloria Ori** Department of Private and Property Law, National Open University of Nigeria, Abuja, Nigeria

**Moses Edwin Osawaru** Department of Plant Biology and Biotechnology, Faculty of Life Sciences, University of Benin, Benin City, Edo State, Nigeria

**Tolulope Osayomi** Department of Geography, University of Ibadan, Ibadan, Nigeria

**Marian Amoakowaah Osei** Department of Physics, Kwame Nkrumah University of Science and Technology, Kumasi, Ghana

**H. O. Oselebe** Department of Crop Production and Landscape Management, Ebonyi State University, Abakaliki, Nigeria

**Harriet Osimbo** Plan International Kenya, Nairobi, Kenya

**Verrah A. Otiende** Pan African University Institute for Basic Sciences Technology and Innovation, Nairobi, Kenya

**Gilbert Ouma** Institute for Climate Change and Adaptation (ICCA), University of Nairobi, Nairobi, Kenya

**Phanuel Owiti** Plan International Kenya, Nairobi, Kenya

**Folasade Mary Owoade** Department of Crop Production and Soil Science, Ladoko Akinola University of Technology, Ogbomoso, Nigeria

**Kwadwo Owusu** Department of Geography and Resource Development, University of Ghana, Legon, Ghana

**Ari Pappinen** School of Forest Sciences, Faculty of Science and Forestry, University of Eastern Finland, Joensuu, Finland

**C. Parwada** Department of Horticulture, Women's University in Africa, Harare, Zimbabwe

**Christian Pauw** NOVA Institute, Pretoria, South Africa

**Keith Phiri** Fort Hare Institute of Social and Economic Research (FHISER), University of Fort Hare, East London, South Africa

**Stuart J. Piketh** Unit for Environmental Sciences and Management, North-West University, Potchefstroom, South Africa

**Kehinde Olayinka Popoola** Department of Urban and Regional Planning, Obafemi Awolowo University, Ile-Ife, Nigeria

**Angelique Pouponneau** Seychelles' Conservation and Climate Adaptation Trust (SeyCCAT), Mahé, Seychelles

**Abi Precious** Chicoco Collective, Port Harcourt, Nigeria

**María Puig** IDOM, Consulting, Engineering, Architecture SAU, Madrid, Spain

**Flora Pule-Meulenberg** Botswana University of Agriculture and Natural Resources, Gaborone, Botswana

**Gandome Mayeul L. D. Quenum** West African Science Service Centre for Climate Change and Adapted Land Use (WASCAL) Graduate Research Program in West African Climate System (GRP-WACS), Federal University of Technology, Akure (FUTA), Akure, Nigeria

Laboratory of Applied Hydrology (LHA), National Institute of Water (NIW), Cotonou, Bénin

**Debadayita Raha** Environmental Sustainability Research Centre, University of Derby, Derby, UK

**Jonty Rawlins** Natural Resources, OneWorld Sustainable Investments, Cape Town, South Africa

**Jules Roberts** GreenFi Systems Ltd, Dublin, Ireland

**Zoe Robinson** School of Geography, Geology and the Environment, Keele University, Staffordshire, UK

**J. T. Rugare** Department of Crop Science, University of Zimbabwe, Harare, Zimbabwe

**Óscar Ruiz** IDOM, Consulting, Engineering, Architecture SAU, Madrid, Spain

**Isaac Rutenberg** CIPIT, Strathmore University, Nairobi, Kenya

**Francis Rutere** Faculty of Social Sciences, St Paul's University, Limuru, Kenya

**Onkangi Ruth** National Construction Authority, Nairobi, Kenya

**Michael Ajanja Sakha** Botany Department, National Museums of Kenya, Nairobi, Kenya

**Armel Sambo** Faculty of Arts, Letters and Human Sciences (FALSH), The University of Maroua, Maroua, Cameroon

**Rebecca Sarku** University for Development Studies, Tamale, Ghana

**Zoyem Tedonfack Sedrique** Department of Geography, Planning and Environment, University of Dschang, Dschang, Cameroon

**Rosemary Shikangalah** Faculty of Humanities and Social Sciences, Department of Geography, History and Environmental Studies, University of Namibia, Windhoek, Namibia

**Conalius E. Shum** School of Agriculture, Environmental Sciences, and Risk Assessment, College of Science, Engineering and Technology (COSET), Institute for Management and Professional Training (IMPT), Yaounde, Cameroon

**Ali Sié** Centre de Recherche en Santé de Nouna (CRSN), Nouna, Burkina Faso

**Siélé Silué** Université Peleforo Gon Coulibaly, Korhogo, Côte d'Ivoire

**Pushendra Kumar Singh** Water Resources Systems Division, National Institute of Hydrology, Roorkee, India

**Wadii Snaibi** Laboratory Communication, Education, Digital Usage and Creativity, ETIGGE Research Team, Bd. Mohammed VI, University Complex, Mohammed Premier Oujda University, Oujda, Morocco

National Institute of the Agronomic Research of Morocco, CRRA of Oujda, Oujda, Morocco

**Julie Snorek** United Nations University Institute for Environment and Human Security (UNU-EHS), UN Campus, Bonn, Germany

Dartmouth College, Hanover, NH, USA

**Victor Sobanke** Research and Planning Department, National Centre for Technology Management, South West Office, Lagos, Nigeria

**Josep María Solé** Meteosim SL. Barcelona Science Park, Barcelona, Spain

**Raïssa Sorgho** Heidelberg Institute of Global Health (HIGH), Heidelberg University, Heidelberg, Germany

**M. K. C. Sridhar** Department of Environmental Health Sciences, Faculty of Public Health, College of Medicine, University of Ibadan, Ibadan, Nigeria

**Denis Ssebugwawo** Department of Computer Science, Kyambogo University, Kampala, Uganda

**Laila Stour** Laboratory of Process Engineering and Environment, Faculty of Sciences and Techniques, Hassan II University of Casablanca, Mohammedia, Morocco

**Barbara Summers** CMAP, Port Harcourt, Nigeria

**Ayodele Idowu Sunday** Department of Fisheries and Aquaculture Technology, Federal University of Technology, Akure (FUTA), Akure, Nigeria

**V. A. Tanimonure** Agricultural Economics Department, Obafemi Awolowo University, Ile-Ife, Nigeria

**Martin Ngankam Tchamba** Department of Forestry, Faculty of Agronomy and Agricultural Sciences, University of Dschang, Dschang, Cameroon

**Brent Tegler** North-South Environment Inc., Campbellville, ON, Canada  
Liana Environmental Consulting Ltd., Fergus, ON, Canada

**Lucie Felicite Temgoua** Department of Forestry, Faculty of Agronomy and Agricultural Sciences, University of Dschang, Dschang, Cameroon

**Argaw Tesfaye** Department of Geography and Environmental Studies, Mekdela Amba University, Mekane Selam, Ethiopia

**Ida Theilade** Department of Food and Resource Economics, Section for Global Development, University of Copenhagen, Copenhagen, Denmark

**H. Tibugari** Department of Plant and Soil Sciences, Gwanda State University, Gwanda, Zimbabwe

**Marie-Louise Tientcheu-Avana** Department of Forestry, Faculty of Agronomy and Agricultural Sciences, University of Dschang, Dschang, Cameroon

**Happy Mathew Tirivangasi** Department of Research Administration and Development, University of Limpopo, Polokwane, South Africa

**Sabine Troeger** Department for Development Research, Geography Institute, University of Bonn, Bonn, Germany

**Nelson Tselaele** Botswana University of Agriculture and Natural Resources, Gaborone, Botswana

**Koray Ulgen** Ege University, Solar Energy Institute, Bornova/Izmir, Turkey

**Chukwuma Otum Ume** Agricultural and Environmental Policy Department, Justus Liebig University Giessen, Giessen, Germany

**Idongesit Michael Umoh** Agricultural Science Education Unit, Department of Science, Redemption Academy, Uyo, Nigeria

**Peter Ulrich** International Global Change Institute and CLIMsystems Ltd, Hamilton, New Zealand

**Dewald van Niekerk** Unit for Environmental Sciences and Management, African Centre for Disaster Studies, North-West University, Potchefstroom, South Africa

**Heike Vogel** Institute of Meteorology and Climate Research, Karlsruhe Institute of Technology (KIT), Karlsruhe, Germany

**Bernhard Vogel** Institute of Meteorology and Climate Research, Karlsruhe Institute of Technology (KIT), Karlsruhe, Germany

**Aliyu Sani Wada** Department of Urban and Regional Planning, Bayero University Kano, Kano, Nigeria

**Abbebe Marra Wagino** Mendel University in Brno Project in Ethiopia, Addis Ababa, Ethiopia

**Joyce Wairimu** Department of Social Sciences, St Paul's University, Limuru, Kenya

**Anselme Wakponou** Faculty of Arts, Letters and Human Sciences (FALSH), The University of Ngaoundéré, Ngaoundéré, Cameroon

**Sue Walker** Division of Agrometeorology, Agricultural Research Council – Soil, Climate and Water, Pretoria, South Africa

Department of Soil, Crop and Climate Sciences, University of the Free State, Bloemfontein, South Africa

**Robert Wild** GreenFi Systems Ltd, Dublin, Ireland

**Steve Woolnough** Department of Meteorology, University of Reading, Reading, UK

**David O. Yawson** Centre for Resource Management and Environmental Studies, The University of the West Indies, Bridgetown, Barbados

**Edmund Yeboah** Heidelberg Institute of Global Health (HIGH), Heidelberg University, Heidelberg, Germany

---

**Véronique Yoboué** Laboratoire de Physique de l'Atmosphère et de Mécaniques des Fluides (LAPA-MF), Université Félix Houphouët-Boigny, Abidjan, Côte d'Ivoire

**Byron Zamasiya** Centre for Applied Social Sciences, University of Zimbabwe, Harare, Zimbabwe

**Cryton Zazu** Environmental Learning Research Centre, Rhodes University, Grahamstown, South Africa

**Leocadia Zhou** Risk and Vulnerability Science Centre (RVSC), University of Fort Hare, Alice, South Africa

**Jethro Zuwarimwe** Institute for Rural Development, University of Venda, Thohoyandou, South Africa

---

**Part I**

**Climate Change, Agriculture, and Food  
Security**



# Adaptation of Seaweed Farmers in Zanzibar to the Impacts of Climate Change

1

Georgia de Jong Cleyndert, Rebecca Newman, Cecile Brugere, Aida Cuni-Sanchez, and Robert Marchant

## Contents

Introduction .....	4
Case Study of Zanzibar .....	5
Conceptual Framework .....	7
Aims and Objectives .....	7
Methods .....	8
Analysis .....	9
Results .....	10
Meteorological Evidence .....	11
Perceived Climatic Changes and Reported Impacts on Seaweed .....	11
Adaptation Strategies and Constraints .....	11
Discussion .....	15
Future Study .....	17
Wider Implications .....	18
Conclusion .....	18
Supplementary Information .....	19
S1: List of Academics and NGOs Contacted During Scoping Phase .....	19
S2: Participant Profiles .....	19
S3: Interview Questions Used as a Guideline for the Semi-structured Interviews .....	20
S4: Coding Strategy Used to Analyse the Seaweed Farming Interview Data .....	22

This chapter was previously published non-open access with exclusive rights reserved by the Publisher. It has been changed retrospectively to open access under a CC BY 4.0 license and the copyright holder is “The Author(s)”. For further details, please see the license information at the end of the chapter.

G. de Jong Cleyndert (✉) · R. Newman · A. Cuni-Sanchez · R. Marchant  
York Institute for Tropical Ecosystems, Department of Environment and Geography, University of York, York, North Yorkshire, UK  
e-mail: [georgiadejongcleyndert@gmail.com](mailto:georgiadejongcleyndert@gmail.com)

C. Brugere  
Soulfish Research and Consultancy, York, UK



S5: Presence Absence Data for Challenges to the Off Bottom Method .....	23
S6: Presence Absence of Challenges for Deepwater and off Bottom Methods .....	24
S7: Percentage of Participants Spending Their Income from Seaweed Farming on Various Items .....	25
References .....	25

---

## Abstract

Seaweed farming is an important alternative livelihood activity that has been heralded as a development success story. It has advanced women's empowerment and economic liberation in coastal communities in Zanzibar, despite recent declines in its production. Using data from 36 semistructured interviews, we explore the impacts of climate change on seaweed farming in Zanzibar and the coping and adaptation strategies available to farmers. Interviews reveal that climatic changes observed in Zanzibar are characterized by increased temperatures, increased winds, and irregular rainfall, and these changes have negatively affected coastal seaweed farming yields and quality. Combined with economic challenges, these environmental stressors are threatening the sustainability of seaweed farming and the wider development impacts that have been gained over the past decades. Establishing seaweed farms in deeper water, using new technologies, could be an adaptation method to overcome rising temperatures; however, there are significant socioeconomic barriers for this to happen. For example, women lack access to boats and the ability to swim. Adaptation options to the increasing impacts of climate change will be possible only with institutional support, significant investment, and through the empowerment of women and the participation local communities.

---

## Keywords

Development · Climate variability · Coastal communities · Gender · Coping strategies

---

## Introduction

The livelihoods of coastal communities are strongly linked to the health of the coastal and marine ecosystems on which they rely (Salafsky and Wollenberg 2000). These socioecological systems are vulnerable to sudden shocks and long-term change, including climate change, and communities often exhibit a high incidence of poverty that can be exacerbated by these shocks (Tobisson 2014; Ferrol-Schulte et al. 2015; Cohen et al. 2016). Alternative and diversification of livelihood activities are popular intervention options aimed at elevating the socioeconomic status of coastal communities and reducing the pressure on marine resources (Sievanen et al. 2005). To be successful, however, these alternative livelihood activities must be resilient to fluctuations in ecological, economic, and social systems (Allison and Ellis 2001; Newman et al. 2020).

Seaweed farming is an alternative livelihood activity that has been promoted in many tropical developing countries (Crawford 2002; Sievanen et al. 2005) because of its low initial capital investment and short-farming cycle (Mshigeni 1973; Valderrama et al. 2015) which provides a fast return on investment (Valderrama et al. 2015). The positive socioeconomic impacts of seaweed farming have been documented in countries including the Philippines, Indonesia, Tanzania, and the Pacific Islands (Sievanen et al. 2005; Msuya 2006a; Namudu and Pickering 2006; Arnold 2008). However, these successes have also been contested (Bryceson 2002; Fröcklin et al. 2012) and seaweed farming is prone to environmental and economic boom-and-bust cycles (Valderrama et al. 2015). This raises questions about its resilience to ecological, economic, and social system fluctuations, particularly the impacts of climate change, and therefore about the sustainability of seaweed farming as an alternative livelihood activity (Allison and Ellis 2001).

## Case Study of Zanzibar

Zanzibar is a semi-independent archipelago within the United Republic of Tanzania and its population rely heavily on a vulnerable marine resource base (Suckall et al. 2014). Seaweed farming was introduced in 1989 using the off-bottom method to farm *Kappaphycus alvarezii* (commercially known as *cottonii*) and *Eucheuma denticulatum* (*spinosum*) in the intertidal zone (Fig. 1) (Msuya 2011). This method involves tying algal fronds to ropes attached between wooden pegs driven into the sediment (Eklöf et al. 2012). Farming cycles are 4–10 weeks, depending on growth rates (Eklöf et al. 2012). Seaweed is dried on the ground over several days and sold to a company to be exported and processed into carrageenan (Fig. 1). Seaweed farming spread rapidly throughout Zanzibar and mainland Tanzania and yearly production increased from 800 tons (dry weight) per year in 1990 to about 11,000 t in 2002 (Eklöf et al. 2012). Farming employs 15,000–20,000 people in Zanzibar, of which 90% are women (Msuya 2006a; Fröcklin et al. 2012). In a traditionally conservative Muslim society, seaweed farming provides women with an opportunity to earn a regular cash income, negotiate household needs, and gain economic independence (Wallevik and Jiddawi 2001). It has been contended that seaweed farming has increased women's security at both the household and community level (Wallevik and Jiddawi 2001). However, despite initial successes, the industry in Zanzibar struggles to compete with global seaweed markets and there has been a production decline of 47% between 2002 and 2012 (Eklöf et al. 2012). The combination of low-sale price and seaweed die-offs, linked to climate change and overgrowth of fouling organisms such as epiphytes (Msuya et al. 2007; Msuya 2011; Eklöf et al. 2012), have caused many farmers to reduce their farm size or abandon the activity altogether (Bryceson 2002; Eklöf et al. 2005).

Adaptation initiatives aim to increase the value of seaweed and improve the livelihoods of the women who farm it. For example, the SeaPoWer project has introduced a new technology to farm *cottonii* (the more valuable species) in the



**Fig. 1** (a) The seaweed farming cycle using the off-bottom method. (Adapted from Fröcklin et al. 2012). Background photo of seaweed farms in Paje, Zanzibar; (b) Fresh *Eucheuma denticulatum* (spinosum); (c) Two piles of seaweed drying on palm leaf matting outside Jambiani village. (All photos taken by the author)

deeper water (>8 m) using tubular nets and has provided a boat and other equipment to two groups of farmers (Brugere et al. 2019). Value addition training has been provided by academics and NGOs to enable women to process seaweed into more valuable products such as soap, shampoo, cookies, and juice (ZaSCI 2019). Some women have formed “clusters” to share costs of equipment and strengthen their business. Another example of an initiative is *The Seaweed Co.*, a business providing seaweed farm tours and products to tourists, where farmers are employed full time and receive a fixed salary. Adaptation initiatives

may increase the sustainability of seaweed farming in Zanzibar; however, their accessibility, effectiveness, and resilience remain to be assessed.

## Conceptual Framework

Sustainable livelihoods, adaptation, and gender equality are key concepts to be considered in relation to the unique socioecological system of seaweed farming in Zanzibar. A livelihood is understood in relation to natural, human, economic, and social capital and is considered sustainable if it can cope with present and future shocks and stresses, while not undermining natural resources (Scoones 1998; Serrat 2017; Quandt 2018). Considering the strong interrelations between environmental conditions and seaweed farming outcomes, attention needs to be paid to the implications of environmental change. Where previous literature has emphasized the challenges that environmental change can pose (Hassan and Othman 2019; Makame and Shackleton 2019) more attention needs to be paid to if, and how, people are responding. Therefore, this study adopts principles from the dynamic environmental sustainability of livelihoods (DESL) framework, which focuses on dynamic responses to change (Newman et al. 2020). Typically, those who are unable to cope, by making temporary adjustments, or to make long-term adaptations are vulnerable and unlikely to attain sustainable livelihoods (Scoones 1998). Responses to shocks and stresses include extensification, intensification, and diversification (Suckall et al. 2014). With regard to seaweed farming, these can be understood as increasing the geographical area where seaweed is farmed, increasing the time spent on the farm, and finally, taking on additional livelihood activities. Long-term adaptations are the actions of individuals, communities and governments undertaken for the purpose of improving or protecting livelihoods (Adger et al. 2005). The capacity to adapt is shaped by socio-institutional factors, including social identities and power relations, which include gender inequalities (Brown and Westaway 2011). The sensitivity of seaweed farming to environmental fluctuations and climate change make it particularly susceptible to shocks and stresses (Msuya and Porter 2014) and the unique nature of this female-dominated industry in the context of gender inequalities in Zanzibar, may impact farmers' ability to adapt. Assessing the viability of coping and long-term adaptation strategies is essential for understanding its future importance as an alternative livelihood activity. As such, we focus on adaptive strategies alongside barriers to adoption whilst critically reflecting on how such barriers might be overcome.

## Aims and Objectives

This study aims to explore whether seaweed farmers in Zanzibar can adapt to climate change to ensure its continued sustainability as a livelihood diversification option. Firstly, we assess the environmental changes that are occurring in Zanzibar and farmers' perceptions of these changes. Secondly, we identify the challenges that women are facing, particularly in relation to climate change, and the effects these

challenges have on production. Finally, we explore how farmers are responding to change, the adaptation strategies available and the barriers to adaptation. In doing so, findings from this work contribute to understanding the effectiveness of adaptation options and to developing recommendations for enhancing the sustainability of seaweed-related interventions.

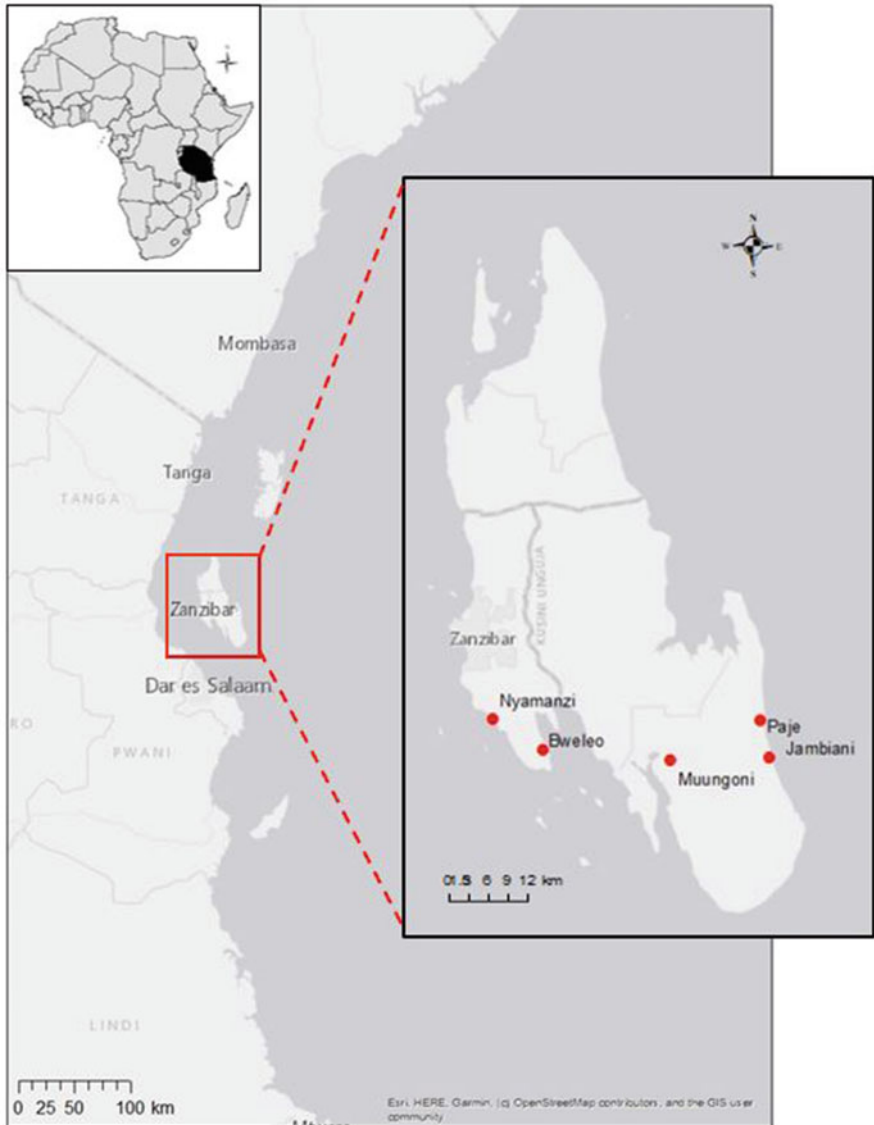
---

## Methods

Meetings took place with key NGOs and academics working with seaweed farming in Zanzibar to contextualize the project and gather additional background information, found in the supplementary information (S1: [List of Academics and NGOs Contacted During Scoping Phase](#)). Thirty-six semistructured interviews were carried out with seaweed farmers from five villages on Unguja, the largest island of the Zanzibar archipelago (Fig. 2, S2: [Participant Profiles](#)); participants were sought with the support of academics and NGOs working in Zanzibar. Thirty-four farmers were female, two were male and ages ranged between 23 and 70, with the average age of 45. Four different groups of farmers were selected to represent different types of seaweed farming options on the island (Table 1). Groups were identified during the scoping phase and a purposive sampling strategy was used to gain representation of the four identified groups of seaweed farmers. This number of participants was deemed an adequate sample size to permit case-orientated analysis while providing a new understanding of experience (Sandelowski 1995).

Interviews were semistructured to allow for supplementary information to be incorporated into the discussion. Interviews were carried out in participants' homes with the assistance of a translator and were recorded using a mobile phone if consent was given. The translator had an academic background in marine sciences and translated from Swahili to English. A meeting was held with the translator before interviews commenced to ensure that translation and interpretation of questions were accurate. Furthermore, to minimize misinterpretation, there was mutual consultation between the translator and the researcher throughout translation during interviews to fully unravel answers (Temple and Young 2004). Six pilot interviews were carried out and questions were adapted to make them clearer for participants and to make the challenges section less restrictive and allow participants to talk more openly and in depth about the challenges they were experiencing.

Questions were developed using themes that were based around the key aims and objectives (S3: [Interview Questions Used as a Guideline for the Semi-structured Interviews](#)). The first section gathered background information to gain understanding about whether farming contributes to financial stability in the household. The second section asked farmers to consider challenges, how these have changed over time and their coping strategies. Adaptation methods were considered by opening up conversation about deepwater farming and value addition (if applicable) and ways to make farming easier. The final question was very open-ended, allowing participants to freely add any information that they deemed important. Interviews lasted between 20 and 40 min. Participants received a small remuneration for their time according to local customs (4000 Tsh / US\$ 1.5).



**Fig. 2** Map of Zanzibar. Red dots indicate villages where participants were interviewed

## Analysis

Interview notes were studied to identify key themes and concepts emerging from the data (Spencer et al. 2003). Thematic categories were based on the objectives but labeled using language from participants to ensure that analysis remained embedded in the data (Spencer et al. 2003). Interview scripts were then systematically coded

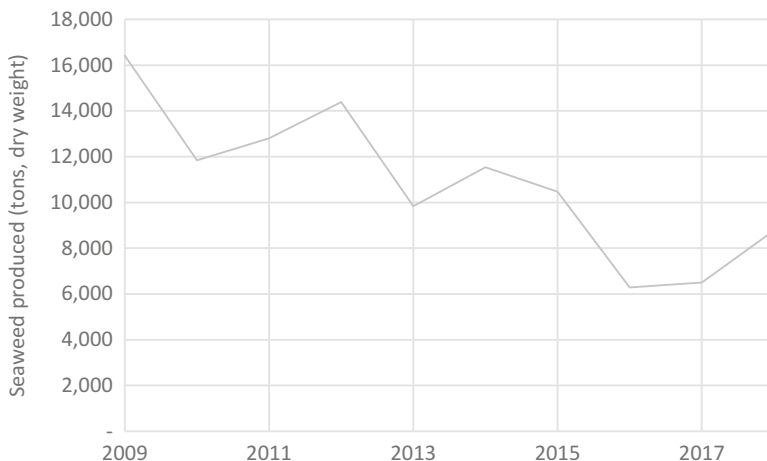
**Table 1** Summary of the groups interviewed. (No. = number of participants)

Group	No.	Description	Method of farming	Value addition?
Independent Farmers	9	Farmers working alone, receiving no institutional support	Off-bottom	✗
Value addition	11	Farmers making value addition products, part of a “cluster”	Off-bottom	✓
Sea PoWer	10	Received equipment and training to farm in the deepwater using tubular nets	Off-bottom and deepwater	✗
<i>Seaweed Co.</i>	6	Employed 6 days per week, receive a wage. Business sells tours to tourists	Off-bottom	✓

under thematic categories using NVivo 12 (version 12.4.0) (S4: [Coding Strategy Used to Analyses the Seaweed Farming Interview Data](#)). Coded information about challenges was organized into a presence-absence data format (S5: [Presence Absence Data for Challenges to the Off Bottom Method](#), S6: [Presence Absence of Challenges for Deepwater and off Bottom Methods](#)). Statistical analyses were carried out using R (version 3.6.0). Fisher’s Exact tests were run to compare challenges across the deepwater farming ( $n = 10$ ) and the off-bottom method ( $n = 36$ ). Further analysis took place by examining recordings and full interview notes to capture detailed illustrative quotes. Quotes were selected to capture the breadth of challenges and emerging themes.

## Results

Seaweed farming is often seen as one of the few options available for women to earn an income. With limited options for other employment, it is an important livelihood activity to alleviate poverty. Income from seaweed farming varied dramatically, ranging from 20,000 to 160,000 Tsh (US\$ 9.00–69.00) per month. Farmers noted the considerably large differences in income when the harvest was “good” or “low.” Challenges to seaweed farming are numerous and farmers indicated that farming has been affected by changes in climatic factors and nonclimatic stressors over the last 20 years. Climatic variables include increased sea temperatures, increased winds, and irregular rainfall (particularly impacting on the ability to dry the harvested seaweed). Other stressors include low market price and health repercussions, such as back pain and skin irritation. The more valuable species, *cottonii*, cannot be farmed in many areas in Zanzibar due to poor growth and die-offs driven by diseases, such as “ice–ice” disease. As a result of challenges, there has been a huge reduction in the number of farmers. For example, the number of farmers in Bweleo has been reduced from 200 to 60 (Seaweed farmer, VA, Bweleo, July 2019). This reduction in farmers echoes a decline in production across Zanzibar (Fig. 3).



**Fig. 3** Seaweed produced in Zanzibar 2009–2018. (Data acquired from Department of Fisheries Development (2019))

## Meteorological Evidence

See Fig. 4.

## Perceived Climatic Changes and Reported Impacts on Seaweed

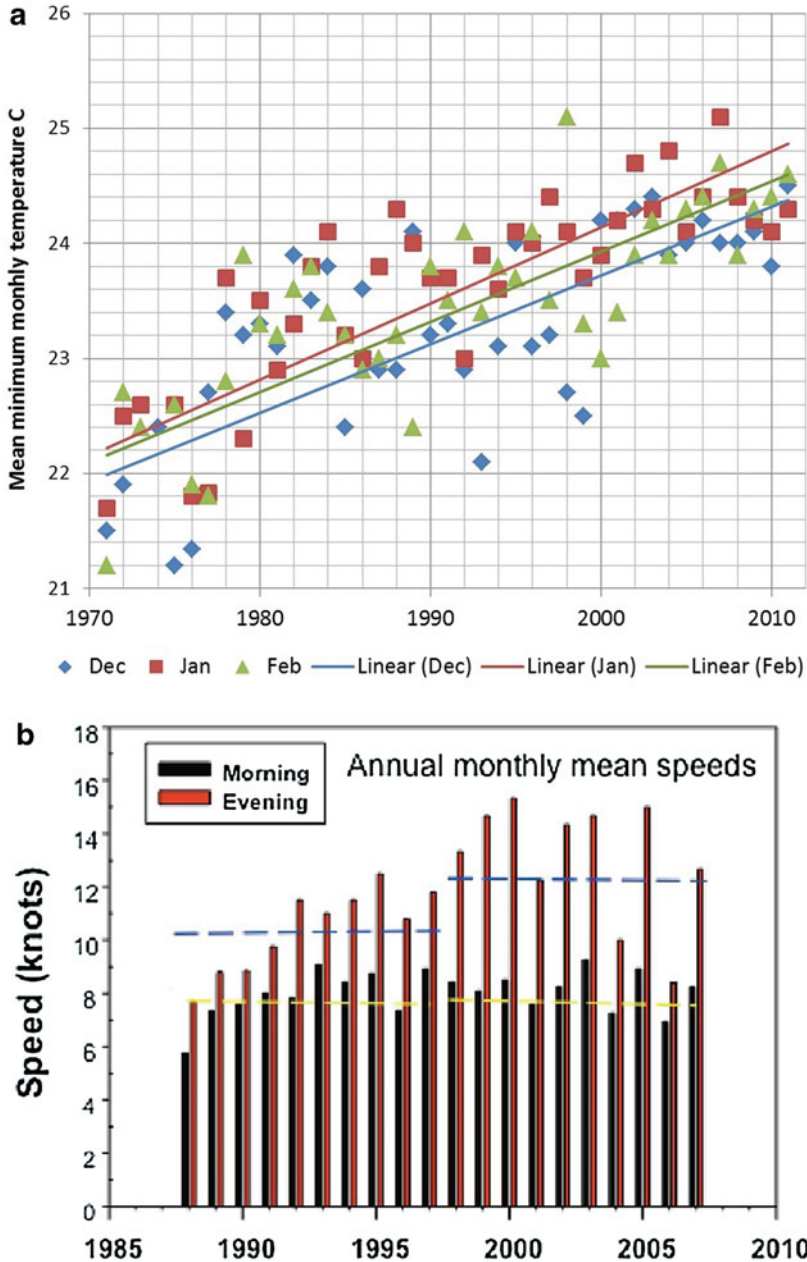
Although some seaweed farmers did not observe climatic change or were unaware of why seaweed was not growing well, many were aware of changes and reported that stressors were having a big impact on seaweed farming, reducing yields. The more valuable species *cottonii* cannot be farmed anymore so farmers have to produce the lower value *spinosum*. Table 2 indicates the effects that climate stressors have on seaweed farming.

## Adaptation Strategies and Constraints

Although some farmers could see no solution to the challenges they faced, there are some adaptation strategies to mitigate the effect of low market price and climatic stressors (Table 3). One coping strategy is to tend to farms more often, using “more energy” to farm. Value addition is an adaptation to the low sale price of seaweed because it can earn more money. However, it does not provide a solution to the problem of a low harvest.

Due to the disease, we try to farm seaweed, but we harvest nothing. If we want to make value addition, we have to buy from other farmers. The solution is to get a boat to farm into the deep water. (Female seaweed farmer partaking in value addition, Bweleo, July 2019)





**Fig. 4** (a) Mean monthly minimum temperature in January and February on Unguja show temperatures have increased strongly over the last 40 years. (Figure from Paul Watkiss, copyright permissions obtained); (b) Trends in annual monthly mean wind speeds for Unguja show that wind speeds have increased in recent decades. (Figure from Mahongo and Francis (2010), copyright permissions obtained)

**Table 2** Effects of climatic stressors on seaweed farming as mentioned by participants

Stressor	Effects	% participants	Example
Increased sea temperatures	More disease – “ice-ice” disease which turns the seaweed white, causes it to rot	61%	<i>There is disease during the summer, the water got hot and boiled the seaweed (Independent female farmer, Paje, July 2017) It is getting worse because now the sun is very high and hot and so the disease is worse (Female seaweed farmer partaking in value addition, Paje, July 2019)</i>
Increased sea temperatures	Epiphytic algae, causes seaweed to rot	28%	<i>There is a type of seagrass that grows on the seaweed and causes it to rot. . . I wanted to cry because there was so much (Female farmer employed at the seaweed business, Paje, July 2019)</i>
Increased wind speed	Lower yields as seaweed breaks off the rope and farms get destroyed	50%	<i>Due to the changing of the weather, the seaweed that we plant gets ripped off by the wind. We plant a lot but when we go to harvest it there is not much there (Independent female farmer, Bweleo, July 2017)</i>
Changes in rainfall patterns	Lower yields as destroys the harvest if it gets wet whilst drying	19%	<i>During the rainfall we plant it but we don't harvest it because it is difficult to dry it (Independent female farmer, Paje, July 2017)</i>

Deepwater farming is a group activity that uses a new technology to farm in the deeper and cooler water. It requires the involvement of men to drive a boat and swim to place nets, although some swimming lessons have been provided to some women. SeaPoWer farmers believed that seaweed grows better in deeper water, particularly the more valuable species *cottonii* and it was believed that the new method addresses environmental challenges. A comparison of the off-bottom method and the deepwater method reveals that disease and seagrass infestation were significantly less of a challenge for farmers using the deepwater technology compared to the off-bottom method (Table 4). However, the deepwater method elevated alternative challenges including the presence of grazers (fish-eating the seaweed) and the need for training (Table 4). Farmers have placed fish traps at the bottom of the tubular nets in the deepwater to capture the herbivorous fish to sell. Interviews reveal that there are constraints to adaptation methods (Table 3). For example, independent farmers expressed a desire to partake in value addition but noted that they lacked training and equipment. Similarly, to farm in the deeper water using the tubular technology, farmers need to learn to swim and dive, and have access to a boat. Currently, farmers have to rely on men because boat skills are highly gendered activities that are

**Table 3** Adaptation strategies to seaweed farming and associated constraints as mentioned by participants

Adaptation	% of participants	Constraint	Example
Tend to farms more often	19%	Takes more time and energy	<i>If there is extra wind, I spend more time because I need to check if the pegs and rope are ok (Female seaweed farmer partaking in value addition, Paje, July 2019)</i> <i>The main challenge is that I use more energy but get less money (Female seaweed farmer partaking in value addition, Paje, July 2019)</i>
Value Addition	50%	Seaweed will not grow	<i>Due to the disease, we try to farm seaweed but we harvest nothing. If we want to make value addition, we have to buy from other farmers (Female seaweed farmer partaking in value addition, Bweleo, July 2019)</i>
		Require training	<i>I would like to make products but I need education on how to do it (Independent female farmer, Paje, July 2019)</i>
		Require equipment	<i>I have had the training but I can't afford the equipment so I can't do it (Female SeaPoWer farmer, Dimani, July 2019)</i>
		Takes too much time	<i>I used to do it in a cluster but we stopped because of time (Independent female farmer, Paje, July 2019)</i>
Deepwater farming	39%	Ability to swim	<i>We would love to know how to swim so that we can participate in planting. We need training (Female SeaPoWer farmer, Dimani, July 2019)</i>
		Ability to dive	<i>Men should be engaged a lot more with seaweed farming. I think it is difficult for the women to dive. I don't think women will be able to dive (Male SeaPoWer farmer, Dimani, July 2019)</i>
		Training to drive the boat	<i>I want to learn to drive the boat myself and not rely on men (Female SeaPoWer farmer, Muungoni, July 2019)</i>
		Access to a boat	<i>If we had a boat we would be able to farm in the deeper water (Independent female farmer, Bweleo, July 2019)</i>
		Grazers	<i>The fish eat the seaweed. We put traps at the bottom but the fish still come (Male SeaPoWer farmer, Dimani, July 2019)</i>

**Table 4** Comparison of the challenges mentioned by participants for seaweed farming using the off-bottom method and deepwater farming. *P* value represents the significance levels from fisher's exact test. \* denotes significant results

Challenge	Off-bottom method	Deepwater	<i>P</i> value
Disease	64%	20%	$p = 0.028^*$
Epiphytes	39%	0%	$p = 0.020^*$
Winds	47%	40%	$p > 0.05$
Grazers	6%	50%	$p = 0.0031^*$
Training	0%	60%	$p = 0.0000022^*$

associated with fishing activity. However, there is strong consensus among the female participants that women would like training to be able to do these activities themselves. These constraints highlight clear socioeconomic barriers to adaptation options.

## Discussion

Seaweed farming, using the off-bottom method, is susceptible to shocks and stresses and climatic changes are clearly having a big impact on seaweed farmers. Initial benefits associated with seaweed farming, such as increased household income and job opportunities, become less obvious as harvests are increasingly unreliable which leads to greater insecurity. Many farmers observed increases in wind speed and temperature, which is in alignment with meteorological data and other studies (Hassan and Othman 2019; Makame and Shackleton 2019). The presence of “ice–ice” disease, which causes a discoloration of the seaweed thali and affects the quality of seaweed, is linked to changes in light intensity and temperature (Largo et al. 1995). The more valuable species (*Cottonii*) is particularly sensitive to environmental fluctuations, and seaweed die-offs caused by “ice–ice” disease is a widespread issue and has been long documented in Zanzibar (Msuya et al. 2014; Msuya and Porter 2014). Moreover, the invasion of epiphytic algae, which causes the seaweed to rot (Critchley et al. 2004; Vairappan 2006), has also been linked to increased variability in water temperatures (Tsiresy et al. 2016). The emotional response of farmers during the interviews to this problem clearly indicates the effect it has on income and human capital because of the economic insecurity and emotional response it causes. The difficulty of high die-off rates and therefore low yields is compounded by irregular rainfall patterns, which cause post-harvest loss of yields if it rains during the drying process, and a low-sale price. The combination of environmental and economic challenges results in a very low income for farmers and therefore threatens the economic capital of farmers by reducing their ability to generate a stable income. Seaweed farming is clearly susceptible to economic and environmental shocks and stresses. Given that future projections estimate that temperatures will increase by 1.5–2 °C by the 2050s (Revolutionary Government of Zanzibar 2013), seaweed die-offs will be exacerbated and its sustainability is

therefore questionable if adaptation is not achieved. Other challenges, such as poor health effects (Fröcklin et al. 2012), further impact sustainability by negatively affected human capital. The off-bottom method is negatively impacting human and economic capital and is becoming increasingly vulnerable to shocks and stresses. Therefore, it is important to understand indigenous perceptions about climate change and its impacts to assess the dynamic responses to changes and to determine suitable adaptation strategies to attain sustainable livelihoods.

There are a number of short-term and long-term adaptation strategies available to farmers. Intensification of farming (i.e., using “more energy” to tend to farms) is a short-term coping strategy in response to low production, high winds, and low sale price. Value addition is a form of long-term diversification, aiming to address the issue of a low sale price that farmers get as a result of their weak bargaining power with seaweed buyers. Interviews reveal that women clearly see the benefit of value addition through an increase in their income. Moreover, deepwater farming can be seen as either a form of extensification or a migration to a new production environment that successfully addresses many environmental challenges and farmers believe that they can earn more money by farming the more valuable species. Although there are still uncertainties regarding the outputs of these long-term adaptation strategies (value addition and deepwater farming), and further monitoring will be required to assess the impact that this has on the farmers’ household income, the attitudes of farmers engaging with these activities are positive. The farming innovations are also bringing about additional benefits such as greater social capital by empowering women producers and elevating women’s status in society (Brugere et al. 2020).

However, successful adaptation requires an enabling environment dependent on environmental, economic, social, and institutional factors and some strategies are more effective than others, particularly in relation to climate change. Although some long-term adaptation strategies are having positive impacts, there are a number of barriers to adaptation that warrant further attention, and adaptive strategies must be analyzed in the context of these barriers to assess their effectiveness. Given that climatic change is a major challenge for seaweed farmers that is likely to be exacerbated in the future, many adaptation strategies will not be adequate in ensuring the long-term sustainability of farming. For example, intensification of farming and value addition activities will not be resistant to climatic stressors because they do not address the inability to grow seaweed. Moreover, there are economic considerations that may inhibit farmers’ ability to adapt; unlike the off-bottom method, deepwater farming and value addition both require large initial investment to purchase equipment. If farmers do not have the financial capacity to make this initial investment, adaptation will not be possible unless enabled through institutional or NGO support (Wright et al. 2014).

Social factors will also either inhibit or enable adaptation. Deepwater farming and value addition both require substantial training and knowledge sharing. Many independent farmers interviewed were aware of adaptation methods but were unable to access them, highlighting the importance of social collaboration as a critical enabling environment to promote knowledge sharing for adaptation (Fu et al. 2011). Moreover, deeply engrained social practices and the complex nature of gender biases and power relations will be significant barriers to overcome for adaptation methods. Labor-led intensification is characterized by an increased time burden,

which disproportionately affects women due to their roles within the household and as child-carers (Wodon and Blackden 2006). Therefore, it is unlikely to be sustainable because of the impact on human and social capital by reducing time available for other roles that are typically dominated by women. The complex nature of gender biases and power relations also significantly affects deepwater farming, which currently entails the involvement of men. Gender power dynamics must be monitored to maintain (and promote) the positive impact to date of seaweed farming on women's security at the household and community level (Wallevik and Jiddawi 2001). Interviews revealed women want to learn to swim and drive the boat to reduce their dependency on men, highlighting a shift in traditional attitudes (Brugere et al. 2019; Brugere et al. 2020). Deepwater farming represents a shift in gender attitudes because it challenges the traditional belief that the deepwater is an area accessed by men due to women's limited mobility and role in society (Fröcklin et al. 2014). The government is promoting gender balance by increasing the number of female village leaders and females in government offices which shows a wider change in gendered roles. However, despite signs of attitude shifts, deeply engrained cultural practices and ways of thinking, held by both men and women, require repeated action, support, and perseverance over extensive periods of time to evolve (Brugere et al. 2019).

Lastly, government involvement will impact the success of adaptation methods by providing (or inhibiting) an institutional enabling environment. Policies and institutions play a major contributing role to the sustainability of coping and adaptation strategies (Osman-Elasha et al. 2006). Governance mechanisms aimed at adaptation can support coping strategies by providing training, technical support, and financial support (Jabeen et al. 2010). It is promising that there is government attention on seaweed farming in Zanzibar, highlighted by the recent appointment of National Seaweed Day to emphasize the importance of the activity and previous governmental attempts to increase the price of seaweed (Davis 2011). Moreover, there are currently plans to construct a processing plant on Pemba which is a large-scale value addition project (IPPmedia 2019). However, the government should be investing in technologies that will be resilient to climate change, not only promoting value addition activities which will be an ineffective coping strategy in the long-term.

Overall, short-term coping strategies are often ineffective and have resulted in many people ceasing to farm as seen by the reduction in farmer numbers in Bweleo and the reduction in production. Although long-term adaptation methods provide promising ways to increase the sustainability of seaweed farming by overcoming economic and environmental challenges, particularly those relating to climate change, there are significant socioeconomic barriers that need to be overcome. This will only be achieved through a supportive enabling environment with participation of local communities and institutional support (Sietz et al. 2011).

## **Future Study**

Although 36 participants was deemed sufficient to enable thorough analysis due to the recurrence of themes during interviews, the study would benefit from incorporating the experiences of farmers on the other islands in Zanzibar, particularly Pemba

where seaweed farming is a particularly important livelihood activity. More investigation is required into the potential cobenefit of using fish traps at deepwater farms to see if the catch of fish can outweigh the loss of seaweed yield. Moreover, there should be more research into drying techniques in order to reduce the post-harvest loss due to irregular rainfall, or the possibility of farmers selling seaweed fresh opposed to dried. Additionally, the complex issue of gender dynamics requires further study, particularly the possible shift in power as a result of extensification into deeper water, which could have major impacts on the long-term sustainability of seaweed farming as a way of empowering women.

## Wider Implications

Seaweed farming is being promoted as an alternative livelihood activity in many tropical developing countries, including Zanzibar, Indonesia, and Philippines. However, it is important that alternative livelihood activities are resilient to ecological and social system fluctuations, particularly climate change (Allison and Ellis 2001). In order to maintain yields, efforts need to focus on seaweed farming adaptation strategies that will be resilient to climate change. Deepwater farming using the new tubular technology shows the most promising adaption method to environmental challenges. However, it requires significant investment and training to ensure its success. Interestingly, despite negative impacts of climate change on the growth of seaweed that have been reported in Zanzibar and elsewhere, seaweed aquaculture is gaining recognition as a climate-change mitigation strategy by its ability to act as a carbon sink (Duarte et al. 2017). Although it would be minor at this scale, it is worth exploring how climate change mitigation policies that provide economic compensation for the environmental benefits brought about by seaweed farming could help investment and could generate a new market for seaweed production (Duarte et al. 2017).

---

## Conclusion

Seaweed farming is still heralded as a success story and is responsible for women's empowerment and economic liberation. However, climatic stressors such as increased sea temperatures, high winds, and variable rainfall reduce seaweed growth and quality. Given the current environmental and socio-economic challenges, seaweed farming provides an unreliable income. Despite the cultural importance as a livelihood activity, the future of seaweed farming is uncertain, particularly as the impacts around climate change are likely to increase. Individual short-term coping strategies, such as intensification of tending to seaweed farms are unlikely to be effective in the long-term. The sustainability of seaweed farming is reliant on long-term adaptation methods that will require adopting new technologies, overcoming significant socioeconomic barriers, and will demand substantial institutional support. It is important to support adaptation strategies that are codesigned with communities, and that use holistic approaches that embrace the technological, individual (social and economic), and institutional dimensions of climate change adaptation.

## Supplementary Information

### S1: List of Academics and NGOs Contacted During Scoping Phase

Name	Organisation
Narriman Jiddawi	Department of Fisheries Development
Flower Msuya	Zanzibar Seaweed Cluster Initiative
Alice Mushi	Milele Foundation
Cecile Brugere	SeaPoWer
N/A	The Seaweed Company

### S2: Participant Profiles

	Participant	Group	Age	Gender	Village	Status	Children	Electricity	Water
1	SWC1	SWC	48	F	Paje	Married	3	1	1
2	SWC2	SWC	33	F	Jambiani	Divorced	5	0	0
3	SWC3	SWC	66	F	Paje	Married	8	0	1
4	SWC4	SWC	44	F	Paje	Married	2	0	1
5	SWC5	SWC	25	F	Paje	Divorced	3	1	1
6	SWC6	SWC	23	F	Paje	Married	0	1	0
7	IND1	IND	34	F	Paje	Divorced	4	1	1
8	IND2	IND	54	F	Paje	Married	8	0	1
9	IND3	IND	70	F	Paje	Divorced	1	0	1
10	IND6	IND	58	F	Paje	Divorced	4	0	0
11	IND7	IND	57	F	Paje	Widowed	3	0	0
12	IND8	IND	39	F	Paje	Widowed	5	0	1
13	IND9	IND	32	F	Paje	Married	4	0	1
14	IND10	IND	42	F	Paje	Divorced	3	1	1
15	IND	IND	51	F	Bweleo	Widowed	6	1	0
16	SP1	SP	64	F	Nyamanzi	Married	5	1	0
17	SP2	SP	46	F	Dimani	Married	6	0	1
18	SP3	SP	48	F	Dimani	Married	12	0	0
19	SP4	SP	40	F	Nyamanzi	Married	3	0	0
20	SP5	SP	41	M	Dimani	Married	3	0	0
21	SP6	SP	38	F	Muongoni	Married	7	1	0
22	SP7	SP	52	F	Muongoni	Married	5	1	0
23	SP8	SP	43	F	Muongoni	Married	2	0	0
24	SP9	SP	52	F	Muongoni	Married	7	1	0
25	SP10	SP	24	F	Muongoni	Married	2	0	0
26	VA1	VA	40	F	Paje	Married	4	1	1
27	VA2	VA	48	F	Paje	Married	3	0	1
28	VA3	VA	46	F	Paje	Married	2	1	1
29	VA4	VA	50	F	Paje	Married	4	1	1

(continued)



	Participant	Group	Age	Gender	Village	Status	Children	Electricity	Water
30	VA5	VA	42	F	Paje	Married	3	1	1
31	VA6	VA	54	F	Bweleo	Married	6	1	0
32	VA7	VA	25	M	Bweleo	Single	0	1	0
33	VA8	VA	45	F	Bweleo	Married	4	1	0
34	VA9	VA	56	F	Bweleo	Married	6	1	0
35	VA10	VA	40	F	Paje	Married	3	0	1
36	Va11	VA	50	F	Paje	Married	6	0	0

### S3: Interview Questions Used as a Guideline for the Semi-structured Interviews

#### Registration:

Age:

Gender:

Village/District:

Single/Married/Widowed:

Number of children:

Electricity in home:

Water piped in the home:

#### Questions

Background

How long have you been farming seaweed?

Why did you decide to start farming seaweed?

What do you think are the main benefits coming from seaweed farming?

What type of method do you use (shallow water/deepwater)?

- If you do both, why? If you changed from the traditional method to the new method, why?
- When did you start farming the new method?

What type of seaweed do you farm? *Cotonii* or *Spinosum*?

How much time do you spend farming seaweed in the traditional/deepwater method?

How many days a week do you spend farming?

#### Economic

Who do you sell the seaweed to?

How much money do you make from seaweed farming per month?

What is the price per unit (kg bag of dried seaweed) Are you able to negotiate the prices?

Which method earns more money? Which species earns more money?

Has the value of the seaweed you farm increased, decreased or stayed the same in the last 20 years?

How essential is seaweed farming to the income of the household?

Do you have any other sources of income other than seaweed farming?

What is the money from seaweed farming spent on?

Do you have a say on how the money from seaweed farming is spent?

What is the cost of the off bottom culture equipment per cycle of production?

If you have farmed using both methods, how do you think the deepwater technique compares with the traditional technique, in terms of

- Seaweed seedlings [more expensive, less expensive, the same]
- Equipment (ropes, pegs versus nets, strings, PVC tubes, boat, petrol. . .)
- Time/labour spent farming (more, less, the same)

**What challenges are you facing? (Off bottom method)**

Does the seaweed grow well?

Are these new/emerging challenges or have they always existed?

Are these challenges increasing/decreasing or staying the same?

Do the challenges vary across different seasons?

How do you respond to/cope with these challenges?

What would help to stop these problems?

Are you facing any health repercussions?

- Have these increased with exposure or stayed the same?
- How do you cope with or manage these health implications?

What does your family think of farming the new method/the old method?

- Does the time taken to farm seaweed affect your family?

Has there been any spatial conflict with other users of the ocean space? – eg does tourism or fisherman prevent you from farming?

- How do you manage this?

Is there anything that would make it easier for you?

**Do you farm in the deepwater?**

How much time do you spend on this?

What effect does this have on your income?

What are the challenges?

**Do you do any value addition** – making products?

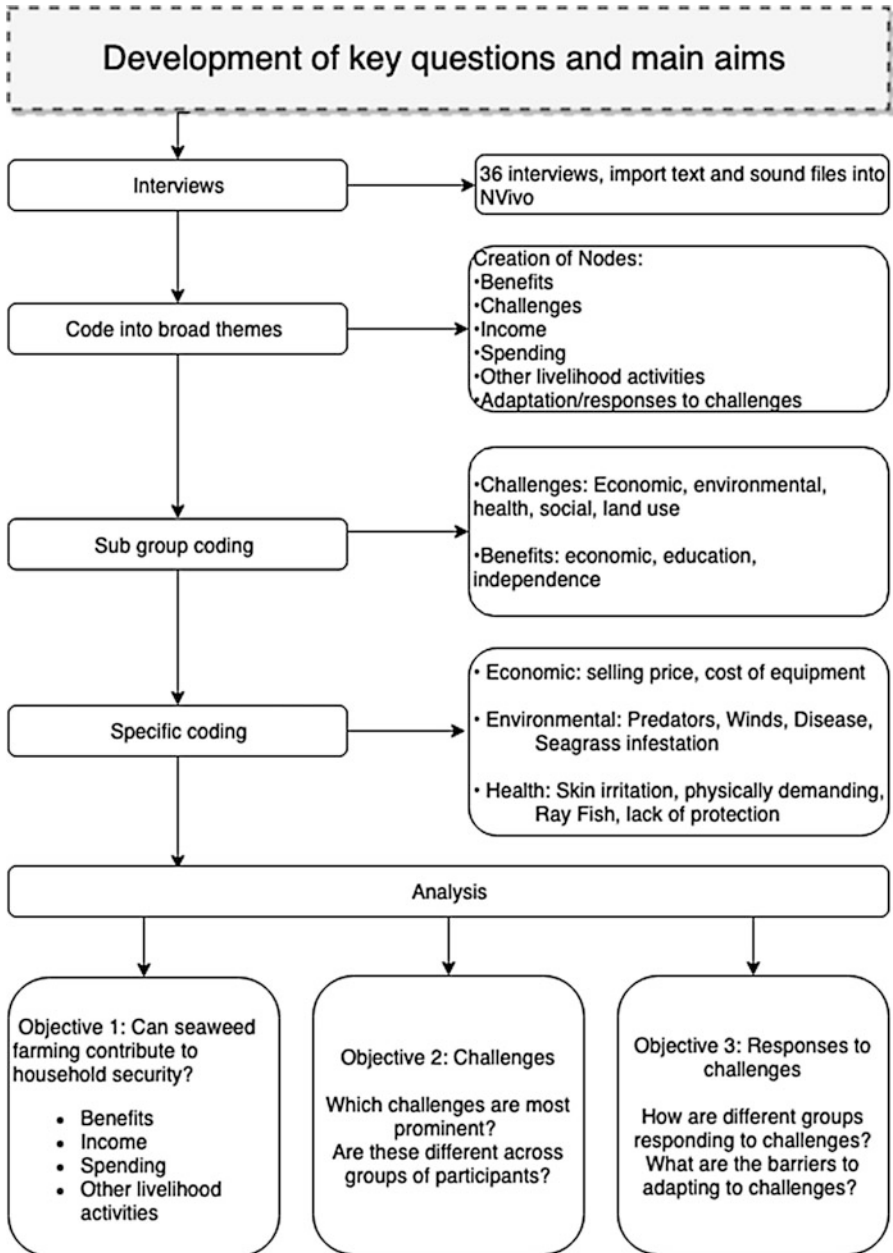
How much time do you spend on making products? What equipment and/or inputs are you using?

How/where do you sell your products?

What products do you make?

Is there anything else that you would like to add or say?

### S4: Coding Strategy Used to Analyses the Seaweed Farming Interview Data



## S5: Presence Absence Data for Challenges to the Off Bottom Method

Group	Method	Price	Equipment	Disease	Seagrass	Climate	Winds	Grazers	Health	Training	SpatialConflict	Dryin
SWC	Off_Bottom	0	0	1	0	1	0	0	1	0	0	0
SWC	Off_Bottom	1	0	1	1	0	0	0	0	0	0	0
SWC	Off_Bottom	1	0	0	1	0	0	0	1	0	0	0
SWC	Off_Bottom	1	0	1	0	1	1	0	0	0	0	0
SWC	Off_Bottom	0	0	0	0	0	1	0	0	0	1	0
SWC	Off_Bottom	0	0	0	1	0	1	0	0	0	0	1
IND	Off_Bottom	1	1	0	1	1	1	0	1	0	1	1
IND	Off_Bottom	1	0	1	0	1	1	0	1	0	0	1
IND	Off_Bottom	1	1	0	1	0	1	0	0	0	0	0
IND	Off_Bottom	1	0	0	0	1	1	1	1	0	1	1
IND	Off_Bottom	1	0	1	0	0	1	0	1	0	1	0
IND	Off_Bottom	1	1	1	0	1	0	0	0	0	1	0
IND	Off_Bottom	1	0	0	0	0	0	0	0	0	1	1
IND	Off_Bottom	1	1	1	0	0	0	0	1	0	0	1
IND	Off_Bottom	0	0	0	1	0	1	1	0	0	0	0
SP	Off_Bottom	1	1	1	1	1	1	0	0	0	0	0
SP	Off_Bottom	1	1	1	1	1	0	0	1	0	0	0
SP	Off_Bottom	1	1	0	1	0	1	0	1	0	1	0
SP	Off_Bottom	0	1	1	1	1	0	0	1	0	0	0
SP	Off_Bottom	0	0	1	0	1	1	0	1	0	0	1
SP	Off_Bottom	1	1	1	0	1	0	0	0	0	1	1
SP	Off_Bottom	0	1	1	0	0	0	0	0	0	1	0
SP	Off_Bottom	0	1	1	0	0	0	0	1	0	1	0
SP	Off_Bottom	0	1	1	0	1	0	0	0	0	0	0
SP	Off_Bottom	0	0	1	0	1	1	0	0	0	1	0
VA	Off_Bottom	1	0	1	0	1	0	0	1	0	1	0
VA	Off_Bottom	1	0	0	1	0	1	0	1	0	0	0
VA	Off_Bottom	0	0	0	0	1	1	0	0	0	1	1
VA	Off_Bottom	1	0	1	0	1	0	0	0	0	1	0
VA	Off_Bottom	1	1	1	0	1	0	0	1	0	0	0
VA	Off_Bottom	0	1	1	0	0	0	0	0	0	0	0
VA	Off_Bottom	1	0	0	1	0	0	0	1	0	1	0
VA	Off_Bottom	0	0	0	1	0	0	0	1	0	0	0
VA	Off_Bottom	1	1	1	0	0	0	0	0	0	0	0
VA	Off_Bottom	0	1	1	1	1	1	0	1	0	1	0
VA	Off_Bottom	0	1	1	0	1	1	0	1	0	1	1

### S6: Presence Absence of Challenges for Deepwater and off Bottom Methods

Group	Method	Equipment	Disease	Seagrass	Climate	Winds	Grazers	Training	SpatialConflict	Health
SWC	Off_Bottom	0	1	0	1	0	0	0	0	0
SWC	Off_Bottom	0	1	1	0	0	0	0	0	0
SWC	Off_Bottom	0	0	1	0	0	0	0	0	1
SWC	Off_Bottom	0	1	0	1	1	0	0	0	0
SWC	Off_Bottom	0	0	0	0	1	0	0	1	0
SWC	Off_Bottom	0	0	1	0	1	0	0	0	0
IND	Off_Bottom	1	0	1	1	1	0	0	1	1
IND	Off_Bottom	0	1	0	1	1	0	0	0	1
IND	Off_Bottom	1	0	1	0	1	0	0	0	0
IND	Off_Bottom	0	0	0	1	1	1	0	1	1
IND	Off_Bottom	0	1	0	0	1	0	0	1	1
IND	Off_Bottom	1	1	0	1	0	0	0	1	0
IND	Off_Bottom	0	0	0	0	0	0	0	1	0
IND	Off_Bottom	1	1	0	0	0	0	0	0	1
IND	Off_Bottom	0	0	1	0	1	1	0	0	0
SP	Off_Bottom	1	1	1	1	1	0	0	0	0
SP	Off_Bottom	1	1	1	1	0	0	0	0	1
SP	Off_Bottom	1	0	1	0	1	0	0	1	1
SP	Off_Bottom	1	1	1	1	0	0	0	0	1
SP	Off_Bottom	0	1	0	1	1	0	0	0	1
SP	Off_Bottom	1	1	0	1	0	0	0	1	0
SP	Off_Bottom	1	1	0	0	0	0	0	1	0
SP	Off_Bottom	1	1	0	0	0	0	0	1	1
SP	Off_Bottom	1	1	0	1	0	0	0	0	0
SP	Off_Bottom	0	1	0	1	1	0	0	1	0
VA	Off_Bottom	0	1	0	1	0	0	0	1	1
VA	Off_Bottom	0	0	1	0	1	0	0	0	1
VA	Off_Bottom	0	0	0	1	1	0	0	1	0
VA	Off_Bottom	0	1	0	1	0	0	0	1	0
VA	Off_Bottom	1	1	0	1	0	0	0	0	1
VA	Off_Bottom	1	1	0	0	0	0	0	0	0
VA	Off_Bottom	0	0	1	0	0	0	0	1	1
VA	Off_Bottom	0	0	1	0	0	0	0	0	1
VA	Off_Bottom	1	1	0	0	0	0	0	0	0
VA	Off_Bottom	1	1	1	1	1	0	0	1	1
VA	Off_Bottom	1	1	0	1	1	0	0	1	1
SP	Deep_Water	0	0	0	0	0	1	0	0	0

(continued)

Group	Method	Equipment	Disease	Seagrass	Climate	Winds	Grazers	Training	SpatialConflict	Health
SP	Deep_Water	0	0	0	0	1	0	1	0	0
SP	Deep_Water	0	0	0	0	0	0	1	0	0
SP	Deep_Water	0	0	0	0	0	1	0	0	0
SP	Deep_Water	0	0	0	0	1	1	1	0	1
SP	Deep_Water	1	0	0	0	0	1	1	1	0
SP	Deep_Water	0	1	0	0	1	0	1	0	0
SP	Deep_Water	0	0	0	0	1	0	0	1	1
SP	Deep_Water	1	1	0	0	0	1	0	0	0
SP	Deep_Water	0	0	0	0	0	0	1	0	0

### S7: Percentage of Participants Spending Their Income from Seaweed Farming on Various Items

Item	% Participants
School fees	69.4%
Food	55.5%
Everyday household expenses	38.9%
Clothes	36.1%
Savings	30.5%
Personal use	27.8%
House renovations	25.0%
Extra household commodities	19.4%

## References

- Adger WN, Arnell NW, Tompkins EL (2005) Successful adaptation to climate change across scales. *Glob Environ Change* 15(2):77–86
- Allison EH, Ellis F (2001) The livelihoods approach and management of small-scale fisheries. *Mar Policy* 25(5):377–388
- Arnold S (2008) Seaweed, power, and markets: a political ecology of the Caluya Islands, Philippines (Major paper). York University, Toronto
- Brown K, Westaway E (2011) Agency, capacity, and resilience to environmental change: lessons from human development, well-being, and disasters. *Annu Rev Environ Resour* 36:321–342
- Brugere C, Msuya FE, Jiddawi N, Nyonje B, Maly R (2019) The introduction of an improved seaweed farming technology for women’s empowerment, livelihoods and environmental protection. Institute of Marine Sciences, Zanzibar. <https://doi.org/10.13140/RG.2.2.34671.69280>

- Brugere C, Msuya FE, Jiddawi N, Nyonje B, Maly R (2020) Can innovation empower? Reflections on introducing tubular nets to women seaweed farmers in Zanzibar. *Gender, Technology and Development*, pp 1–21
- Bryceson I (2002) Coastal aquaculture developments in Tanzania. Sustainable and non-sustainable experiences. *West Indian Ocean J Mar Sci* 1:1–10
- Cohen PJ, Lawless S, Dyer M, Morgan M, Saeni E, Teioli H, Kantor P (2016) Understanding adaptive capacity and capacity to innovate in social–ecological systems: applying a gender lens. *Ambio* 45(3):309–321
- Crawford B (2002) Seaweed farming: an alternative livelihood for small-scale fishers. Coastal Resources Center, Narragansett
- Critchley AT, Largo D, Wee W, Bleicher L'honneur G, Hurtado AQ, Schubert J (2004) A preliminary summary on Kappaphycus farming and the impact of epiphytes. *Japanese J Phycol* 52(Supplement):231–232
- Davis E (2011) Seaweed farmer education: is it enough to sustain the industry? Analyzing the status of stakeholder investment in Muungoni and Jambiani, Unguja. Independent Study Project (ISP) Collection. 1195. [https://digitalcollections.sit.edu/isp\\_collection/1195](https://digitalcollections.sit.edu/isp_collection/1195)
- Department of Fisheries Development (2019) Export of Seaweed for the period 2008–2018. Ministry of Agriculture, Natural Resources, Livestock and Fisheries
- Duarte CM, Wu J, Xiao X, Bruhn A, Krause-Jensen D (2017) Can seaweed farming play a role in climate change mitigation and adaptation? *Front Mar Sci* 4:100
- Eklöf JS, de la Torre Castro M, Adelsköld L, Jiddawi NS, Kautsky N (2005) Differences in macrofaunal and seagrass assemblages in seagrass beds with and without seaweed farms. *Estuar Coast Shelf Sci* 63(3):385–396
- Eklöf JS, Msuya FE, Lyimo TJ, Buriyo AS (2012) Seaweed farming in Chwaka Bay: a sustainable alternative in aquaculture. People, nature and research in Chwaka Bay. WIOMSA, Zanzibar, pp 213–233
- Ferrol-Schulte D et al (2015) Coastal livelihood vulnerability to marine resource degradation: a review of the Indonesian national coastal and marine policy framework. *Mar Policy*. Pergamon 52:163–171
- Fröcklin S et al (2012) Seaweed mariculture as a development project in Zanzibar, East Africa: a price too high to pay? *Aquaculture Elsevier* 356–357:30–39
- Fröcklin S, de la Torre-Castro M, Håkansson E, Carlsson A, Magnusson M, Jiddawi NS (2014) Towards improved management of tropical invertebrate fisheries: including time series and gender. *PLoS One* 9(3):e91161
- Hassan IH, Othman WJ (2019) Seaweed (Mwani) farming as an adaptation strategy to impacts of climate change and variability in Zanzibar. In: *Climate change and coastal resources in Tanzania*. Springer, Cham, pp 53–68
- IPPmedia (2019) Zanzibar in final stages to construct a giant seaweed processing plant. <https://ippmedia.com/en/business/zanzibar-final-stages-construct-giant-seaweed-processing-plant>. Accessed 8 Sept 2019
- Jabeen H, Johnson C, Allen A (2010) Built-in resilience: learning from grassroots coping strategies for climate variability. *Environ Urban* 22(2):415–431
- Largo DB, Fukami K, Nishijima T (1995) Occasional pathogenic bacteria promoting ice-ice disease in the carrageenan-producing red algae *Kappaphycus alvarezii* and *Eucheuma denticulatum* (Solieriaceae, Gigartinales, Rhodophyta). *J Appl Phycol* 7(6):545–554
- Mahongo SB, Francis J (2010) Monthly variations in sea level at the island of Zanzibar. *Western Indian Ocean J Mar Sci* 9(1):1–16
- Makame MO, Shackleton S (2019) Perceptions of climate variability and change in relation to observed data among two east coast communities in Zanzibar, East Africa. *Clim Dev*:1–13
- Msuya FE (2006a) The impact of seaweed farming on the social and economic structure of seaweed farming communities in Zanzibar, Tanzania. *World Seaweed Resources*, Version, 1, p 27

- Msuya FE (2006b, September) The seaweed cluster initiative in Zanzibar, Tanzania. In: Proceedings of the 3rd regional conference on innovation systems and innovative clusters in Africa, Dar es Salaam, Tanzania, pp 246–260
- Msuya FE (2011) The impact of seaweed farming on the socioeconomic status of coastal communities in Zanzibar, Tanzania. *World Aquacult* 42(3):45–48
- Msuya FE, Porter M (2014) Impact of environmental changes on farmed seaweed and farmers: the case of Songo Songo Island, Tanzania. *J Appl Phycol* 26(5):2135–2141
- Msuya FE, Shalli MS, Sullivan K, Crawford B, Tobey J, Mmochi AJ (2007) A comparative economic analysis of two seaweed farming methods in Tanzania. The Sustainable Coastal Communities and Ecosystems Program. Coastal Resources Center, University of Rhode Island and the Western Indian Ocean Marine Science Association.
- Msuya FE, Buriyo A, Omar I, Pascal B, Narrain K, Ravina JJ, Mrabu E, Wakibia JG (2014) Cultivation and utilisation of red seaweeds in the Western Indian Ocean (WIO) region. *J Appl Phycol* 26(2):699–705
- Namudu MT, Pickering TD (2006) Rapid survey technique using socio-economic indicators to assess the suitability of Pacific Island rural communities for *Kappaphycus* seaweed farming development. In: Eighteenth international seaweed symposium. Springer, Dordrecht, pp 15–23
- Newman RJS, Capitani C, Courtney-Mustaphi C, Thorn JPR, Kariuki R, Enns C, Marchant R (2020) Integrating insights from social-ecological interactions into sustainable land use change scenarios for Small Islands in the Western Indian Ocean. *Sustainability* 12(4):1340
- Osman-Elasha B, Goutbi N, Spanger-Siegfried E, Dougherty B, Hanafi A, Zakieldeen S, Sanjak A, Atti HA, Elhassan HM (2006) Adaptation strategies to increase human resilience against climate variability and change: lessons from the arid regions of Sudan. Assessments of impacts and adaptations to climate change (AIACC) working paper, 42
- Quandt A (2018) Measuring livelihood resilience: the household livelihood resilience approach (HLRA). *World Dev* 107:253–263
- Revolutionary Government of Zanzibar (2013) Zanzibar climate change strategy. <http://www.paulwatkiss.co.uk/newimagesanddocs/ZanzibarSummaryLRdraftfinal.pdf>. Accessed 2 Sept 2019
- Salafsky N, Wollenberg E (2000) Linking livelihoods and conservation: a conceptual framework and scale for assessing the integration of human needs and biodiversity. *World Dev* 28(8):1421–1438
- Sandelowski M (1995) Sample size in qualitative research. *Res Nurs Health* 18(2):179–183
- Scoones I (1998) Sustainable rural livelihoods: a framework for analysis. IDS working paper no. 72, Institute of Development Studies, Brighton
- Serrat O (2017) The sustainable livelihoods approach. In: Knowledge solutions. Springer Singapore, Singapore, pp 21–26
- Sietz D, Boschuttz M, Klein RJT (2011) Mainstreaming climate adaptation into development assistance: rationale, institutional barriers and opportunities in Mozambique. *Environ Sci Policy* 14(4):493–502
- Sievanen L, Crawford B, Pollnac R, Lowe C (2005) Weeding through assumptions of livelihood approaches in ICM: seaweed farming in the Philippines and Indonesia. *Ocean Coast Manag* 48(3–6):297–313
- Spencer L, Ritchie J, O'Connor W (2003) Analysis: practices, principles and processes. *Qualitative research practice: a guide for social science students and researchers*, SAGE, London, 199, p 218
- Suckall N, Tompkins E, Stringer L (2014) Identifying trade-offs between adaptation, mitigation and development in community responses to climate and socio-economic stresses: Evidence from Zanzibar, Tanzania. *Appl Geogr Pergamon* 46:111–121
- Temple B, Young A (2004) Qualitative research and translation dilemmas. *Qual Res* 4(2):161–178
- Tobisson E (2014) Consequences and challenges of tourism and seaweed farming: a narrative on a coastal community in Zanzibar. *Western Indian Ocean J Mar Sci* 12(2):169–184



- Tsiresy G, Preux J, Lavitra T, Dubois P, Lepoint G, Eeckhaut I (2016) Phenology of farmed seaweed *Kappaphycus alvarezii* infestation by the parasitic epiphyte *Polysiphonia* sp. in Madagascar. *J Appl Phycol* 28(5):2903–2914
- Vairappan CS (2006) Seasonal occurrences of epiphytic algae on the commercially cultivated red alga *Kappaphycus alvarezii*. *J Appl Phycol* 18(3–5):611–617
- Valderrama D et al (2015) The economics of *Kappaphycus* seaweed cultivation in developing countries: a comparative analysis of farming systems. *Aquac Econ Manag* 19(2):251–277
- Wallevik HB, Jiddawi N (2001) Impacts of tourism on the activities of the women of the southeast coast of Unguja, Zanzibar. In *Marine Science Development in Tanzania and Eastern Africa. Proceedings of the 20 th Anniversary Conference on Advances in Marine Science in Tanzania* 28:535–550
- Wodon Q, Blackden CM eds., (2006) *Gender, time use, and poverty in sub-Saharan Africa*. The World Bank
- Wright H, Vermeulen S, Laganda G, Olupot M, Ampaire E, Jat ML (2014) Farmers, food and climate change: ensuring community-based adaptation is mainstreamed into agricultural programmes. *Clim Dev* 6(4):318–328
- ZaSCi (2019) Zanzibar Seaweed cluster initiative. [https://www.mzfn.org/Advocacy\\_For\\_Seaweed.html](https://www.mzfn.org/Advocacy_For_Seaweed.html). Date accessed 2/09/19

**Open Access** This chapter is licensed under the terms of the Creative Commons Attribution 4.0 International License (<http://creativecommons.org/licenses/by/4.0/>), which permits use, sharing, adaptation, distribution and reproduction in any medium or format, as long as you give appropriate credit to the original author(s) and the source, provide a link to the Creative Commons license and indicate if changes were made.

The images or other third party material in this chapter are included in the chapter's Creative Commons license, unless indicated otherwise in a credit line to the material. If material is not included in the chapter's Creative Commons license and your intended use is not permitted by statutory regulation or exceeds the permitted use, you will need to obtain permission directly from the copyright holder.





# Adaptation of Small-Scale Tea and Coffee Farmers in Kenya to Climate Change

# 2

Alice Nyawira Karuri

## Contents

Introduction .....	30
Agriculture in Kenya .....	30
Climate Change Policies and Regulations in Kenya .....	31
Tea Sector in Kenya .....	32
Climate Change Challenges in the Tea Sector .....	34
Adaptation and Mitigation Measures by Small-Scale Farmers in the Tea Sector .....	34
Coffee Sector in Kenya .....	38
Climate Change Challenges in the Coffee Sector .....	39
Adaptation and Mitigation Measures by Small-Scale Farmers in the Coffee Sector .....	40
Recommendations and Conclusion .....	42
Farmer Empowerment .....	42
Strengthening of Institutions .....	43
Collaborations and Partnerships .....	44
Certification .....	44
References .....	45

## Abstract

The adverse effect of climate change on agriculture is well-documented and is a cause of concern for governments globally. In addition to concerns over food crop production, the economies of numerous developing countries rely heavily on cash crops. The coffee and tea sectors are key in Kenya's economy, contributing significantly to the gross domestic product, foreign exchange, and the direct or

---

This chapter was previously published non-open access with exclusive rights reserved by the Publisher. It has been changed retrospectively to open access under a CC BY 4.0 license and the copyright holder is "The Author(s)". For further details, please see the license information at the end of the chapter.

---

A. N. Karuri (✉)

School of Humanities and Social Sciences, Strathmore University, Nairobi, Kenya

e-mail: [akaruri@strathmore.edu](mailto:akaruri@strathmore.edu)

© The Author(s) 2021

W. Leal Filho et al. (eds.), *African Handbook of Climate Change Adaptation*,  
[https://doi.org/10.1007/978-3-030-45106-6\\_70](https://doi.org/10.1007/978-3-030-45106-6_70)

29

indirect employment of millions. Farmers engaged in the production of coffee and tea are predominantly small-scale farmers, with the majority farming on less than five acres. Climate change poses a threat to the production of these two crops and by extension to the economy of Kenya and the livelihood of farmers and those employed in these sectors. This study identifies the challenges posed by climate change in the tea and coffee sectors, the adaptation and mitigation measures identified, and the scope of their implementation. The production, processing, and marketing of tea and coffee in Kenya differs widely in terms of the institutions and institutional arrangements in the two sectors. This study will therefore analyze the role played by institutions in both sectors and how this affects climate change adaptation and mitigation measures by small-scale farmers.

---

**Keywords**

Kenya · Tea · Coffee · Small-scale farmers · Climate change adaptation · Institutions

---

## Introduction

### Agriculture in Kenya

The agriculture sector is key to Kenya's economy. It accounts for 65% of the export earnings and provides the livelihood of more than 80% of the population. The sector employs more than 40% of the total population and about 70% of the rural population. In 2018, it contributed 34.2% of Kenya's gross domestic product (GDP) and an additional 27% through linkages to other sectors such as manufacturing, distribution, and services (Food and Agriculture Organization (FAO) 2020; Kenya National Bureau of Statistics (KNBS) 2019; Ministry of Agriculture, Livestock and Fisheries (MALF) 2020). The climate of Kenya varies from tropical along the coast to arid in the interior. The weather in Kenya is generally sunny year-round, with the main rainy seasons being from March to May and from November to December (International Coffee Organization (ICO) 2019a). The topography rises from the coastal plains to the eastern edge of the East African Plateau and the Great Rift Valley. The highest altitude is in the central region and temperatures of 15 °C compared to the coastal region with temperatures of 29 °C (UNDP 2020). The Agriculture in Kenya is 98% rain fed and highly sensitive to changes in temperature and rainfall. Studies indicate there will be a 20% decrease in rainfall by the year 2030 (Government of Kenya (GoK) 2015). Temperatures are projected to increase 1.2–2.2 °C by 2050 in addition to increase in frequency and intensity of heavy rainfall, increase in severity of dry spells and duration of heat waves, and 16–42 cm rise in sea level (United States Agency for International Development (USAID) 2018). Since the early 1960s, both minimum and maximum temperatures have been increasing. The minimum temperature has risen generally by 0.7–2.0 °C and the maximum by 0.2–1.3 °C. There has been increased variability of rainfall from year to year and during the year. Extreme weather occurrences such as droughts and floods have become frequent and intense, leading to crop failures.

The adverse impacts of climate change are compounded by human factors such as illegal encroachments and settlements, logging and livestock grazing, which exacerbate deforestation, land degradation, and desertification. Forest cover in Kenya, for instance, has fallen from 12% in the 1960s to less than 2% in 2010. Kenya has a landmass of about 582,350 km<sup>2</sup> with 17% being arable while 83% consists of arid and semiarid land (ASAL) (GoK 2010). The combination of deforestation to open up croplands, the extension of agriculture onto land with low potential, and the use of more basic farming techniques and technologies due to cost and capacity barriers make the current agricultural system unsustainable in the long term (Republic of Kenya 2018). This necessitates that farmers engage in activities to adapt to and mitigate climate change. Adaptation refers to actions that minimize negative impacts of climate change, including the social, environmental, and economic impacts while mitigation refers to activities that reduce, prevent, or remove greenhouse gas (GHG) emissions and therefore reduce climate change. These measures require that farmers engage in sustainable agriculture, which is defined as farming in a responsible manner while enhancing profitability, well-being of the people, and the environment for now and the future (Cameron 2017).

The MALF oversees agriculture in the country. The Agriculture and Food Authority (AFA) is a government agency under MALF and is responsible for the development, regulation, and promotion of scheduled crops (ICO 2019b). AFA is comprised of several directorates that are specific to particular crops and include the Tea Directorate and the Coffee Directorate. Tea, horticulture, and coffee are Kenya's main agricultural exports. Tea and coffee are, however, unique as they are predominantly grown by small-scale farmers. This necessitates the formation of farmer organizations to benefit from economies of scale and to navigate the labor and capital-intensive process from production at the farm to the sale of the finished products.

## Climate Change Policies and Regulations in Kenya

Kenya recognizes the importance of climate change action and has policies and plans to enact adaptation and mitigation measures. These include the National Climate Change Response Strategy (NCCRS) of 2010, National Policy on Climate Finance (2015), the Climate Change Act of 2016, the National Climate Change Action Plan (NCCAP) 2018–2022, and the National Adaptation Plan 2015–2030. The Environmental Management and Coordination Act (EMCA) of 1999 is the framework law on environmental management and conservation. Under this Act, EMCA established various institutions including the National Environmental Management Authority (NEMA). NEMA is the principal instrument of government charged with the implementation of all policies relating to the environment, and to exercise general supervision and coordination over all matters relating to the environment (National Environmental Management Authority 2020).

The NCCRS is the main document that guides the Kenya government's climate change agenda. The main focus of the strategy is to ensure that adaptation and mitigation measures are integrated in all government planning, budgeting, and development objectives. It prioritizes agriculture as one of the vulnerable sectors

of the economy. The NCCRS established that the institutions in place to govern climate change affairs were inadequate and recommended that a comprehensive climate change policy and related legislation be put in place. The Climate Change Act was subsequently passed in 2016 and provides for a regulatory framework for an enhanced response to climate change. The Climate Change Act pertains to all sectors of the economy and to the national and county level government in the 47 counties of Kenya. It aims to mainstream climate change responses into development planning, provide incentives and obligations for private sector contributions in achieving low carbon climate resilient development, promote low carbon technologies, facilitate climate change research, and enhance cooperative climate change governance between the national government and county governments.

The Act obligates the Cabinet Secretary responsible for climate change affairs to formulate a five-year NCCAP. In accordance with the Act, the NCCAP represents the national mechanism through which climate change will be addressed in Kenya, including the implementation of the Nationally Determined Contributions (NDCs). Kenya submitted its NDCs in 2016. The NCCAP 2018–2022 provides mechanisms for mainstreaming climate change into all sectors of the economy and in the County Integrated Development Plans (CIDPs). The initiatives undertaken through the NCCAP include the scale up of renewable energy technologies, clean energy solutions, improved water resource management, sustainable forest management and tree planting, climate smart agriculture, and agroforestry (GoK 2015). It prescribes measures and mechanisms for climate change adaptation and mitigation, and the review and recommendation of duties of public and private bodies on climate change. Climate change duties refer to the statutory obligations conferred on public and private entities to implement climate change actions consistent with the national goal of low carbon climate resilient development. NEMA monitors, investigates, and reports on compliance with the assigned climate change duties. The Act also provided for financial provisions through the Climate Change Fund, which is a financing mechanism for priority climate change actions and interventions (Republic of Kenya 2016). Kenya also has a Climate Smart Agriculture Strategy for 2017–2026, which has been used as a source of input for the development of NCCAP 2018–2022 (Republic of Kenya 2018).

---

## Tea Sector in Kenya

Kenya is the third largest producer of black tea globally after China and India, and is the world's largest exporter of black tea, contributing over 20% of total world exports. The sector is therefore significant to the global and national economy. By 2012 the sector accounted for 17% of total export earnings and 4 % of the national GDP (FAO 2015). In 2018, tea earnings amounted to Ksh.127.7 billion (KNBS 2019). Tea is grown on 236,000 ha with smallholders cultivating 142,000 ha and estates 93,000 ha. Tea production in 2018 was 493,000MT with 272,500MT from smallholders and 220,500 from estates (KNBS 2019). The tea sector contributes to

environmental conservation through improved water infiltration, reduced surface erosion rates, and enhanced carbon sequestration.

Tea farming in Kenya is regulated by the Tea Act, Revised Edition 2012 [1960]. The Tea Directorate undertakes regulation and compliance of the tea industry, marketing and promotion of tea, the provision of technical and advisory services, and tea export guidelines. It facilitates research on all tea-related matters through the Tea Research Institute (TRI). All tea farmers are required to register with a factory as shareholders and to which they must supply the entirety of their production. Nearly all tea factories with small-scale farmer membership are shareholders in the Kenya Tea Development Agency (KTDA), a management company with several subsidiaries. Acreage per farmer varies from 0.25 to over 50 acres and most KTDA farmers grow on approximately half an acre of tea on average. Majority rely heavily on tea production for their livelihoods, which comprises over 60% of their total income. KTDA works directly with 611,000 farmers and indirectly impacts over four million people. A 2.5% management fee based on net price for services rendered is paid to KTDA Management Services and KTDA subsidiaries charge for their services separately. The government supports KTDA through guarantees for loans and support to extension services through the Ministry of Agriculture. The Kenya Tea Growers Association (KTGA) was established to promote the common interests of large-scale tea growers and is open to growers who maintain over 10 ha of tea. The large-scale tea sector, also referred to as tea plantation, includes both individual farmers and corporations, and accounts for about 40% of total tea production in Kenya (Kenya Tea Growers Association (KTGA) 2016). Challenges in the tea sector include declining prices, low yields, high production costs, low production diversification, low value addition, and a multiplicity of taxes and levies (Ngumo 2015).

The agro-climatic requirements of tea are temperatures ranging from 10 °C to 30 °C, ideally 0.5–10 degree slopes, elevations up to 2,000 m, acidic volcanic soils, well-distributed rainfall between the range of 1,200 and 1,400 mm annually, sufficient sunshine hours, and a mild climate. Tea in Kenya is grown in altitudes between 1,500 m and 2,700 m above sea level, receiving 1,200–1,400 mm of rainfall annually, which is spread throughout the year (FAO 2015). The agro-zones for tea production include the areas of Mount Kenya, Aberdare Range, Nyambene Hills, Mau Escarpment, Kericho Highlands, the hills of Nandi and Kisii, Mount Elgon, and Cherangani Hills (FAO 2015). Tea production in Kenya occurs all year round but the highest yields are in the rainy seasons in March–June and October–December. The tea supply is consistent throughout the year in both quantity and quality. Over 90% of tea from Kenya is handpicked, with only the top two leaves and a bud being picked for processing to ensure high quality. About 50 varieties of tea have been developed to suit the seven tea growing regions. The tea is grown without the use of agrochemicals as it is pest and disease free, and requires only fertilizer to replenish soil (TRFK 2010). Tea husbandry includes weeding, pruning, and fertilizer application. Pruning is ideally undertaken at the end of the peak-growing period, July to August, when the soil moisture is still adequate (East Africa Tea Trade Association 2020). The weather during this period is usually cold with light rains and enables pruning to occur without sun scorch.

## Climate Change Challenges in the Tea Sector

Tea production is highly sensitive to changes in growing conditions. These conditions are expected to be impacted by climate change (Change 2015). Climate changes include inadequate rainfall, a larger soil water deficit, unpredictable rain patterns, and temperature rise (Ethical Trade Partnership (ETP) 2011). Climate change causes low productivity and poor quality in tea. Drought reduces the yields of tea while changes in the reliability and predictability of rainfall distribution and patterns have negative effects on tea yields and quality. Hailstorms and frost damage tea leaves and extreme temperatures suppress yields. High temperatures for example lead to decreased yields, reduced quality, high evaporation, reduced water content in the tea, dry weather pests, aggressive weed growth, weeds found in low country appearing in mid and up country poor bud break, bud scorch, stem and collar canker, wood rot, leaf and bark desiccation. Excessive rain causes spread of fungal diseases, wet weather pests, and poor drainage in low-lying areas, heavy soil erosion that results in reduced water holding capacity, poor soil nutrients, and poor bud break and shoot development. Increase in extreme weather causes crop damage and failure due to events such as droughts, hail, storms, floods, frost, and landslides. Climate change also reduces productivity of subsistence crops which reduces food security (International Trade Center (ITC) 2014; Prematilake 2014). Due to climate change, the current areas of production are becoming unsuitable for tea production due to the risk of increasing temperature and increasing pests and diseases (ITC 2019; USAID 2018). A study by the International Center for Tropical Agriculture (CIAT) of climate change impacts on tea production in Kenya up to 2050, estimated that with increasing temperatures and rainfall, optimal areas for tea production will decrease, and production will have to shift to higher altitude areas, moving from around 1,500 m to 2,000 m above sea level (Ethical Tea Partnership 2011). A study by TRI indicates that in 2012, almost one-third of the harvest was lost (Omondi 2015). Incidences of severe and damaging frost that are attributed to climate change are becoming more common in Kenya. For example, the 2012 frost resulted in 30% tea crop loss in Nandi County (GoK 2015).

## Adaptation and Mitigation Measures by Small-Scale Farmers in the Tea Sector

Tea planting is done through the planting of seedlings or more rarely, through the transplanting of a tree plant. Maturation of the tea seedling takes approximately 3 years, after which the tree plant continues production for decades. Adaptation to climate change can therefore not be carried out through adjusting the planting date. Adaptation measures can however be taken through adjusting the timing of tea husbandry activities such as pruning and fertilizer application, to climate change. Toward addressing issues on climate change, TRI is developing new technologies including environmental conservation efforts and development of improved tea varieties. TRI conducts research aimed at improving planting material, husbandry,

yields, quality, and disease and pests control. It also provides advisory services to the growers on specific problems encountered in tea cultivation. The TRI has developed over 914 improved clones, of which 51 clones have been selected for consistent superiority in yield and quality. Thirteen of these clones yield between 5,000 and 8,000 kg of processed tea per hectare annually. These yield levels are some of the highest in the world and are three times the average yields of unimproved tea varieties. It has also developed a new tea clone – “Purple tea.” According to the Kenya Agriculture and Livestock Research Organization (KALRO), the TRI began research on the “Purple Tea” cultivar over 25 years ago, and in 2011, the Tea Directorate began encouraging farmers to plant it. It is drought, frost, disease, and pest resistant. It has wide adaptability and is suitable for all designated tea-growing regions (KALRO 2020). Production of tea varieties such as purple tea, which is more resistant to climate variability than green tea, is a climate adaptation measure with the potential for higher income for tea farmers. Kimtai (2019) did a study aimed at establishing the rate of adoption of purple tea farming, determining the socioeconomic factors that hinders adoption and determining the role of purple tea farming for carbon sequestration. The purple variety had higher production than green tea and fetched higher prices. It was more resistant to drought, frost, hailstone, pests, and diseases. It was therefore highly rated for impacts of climate variability and change. Constraints to farming purple tea included availability of land, extension services were low particularly to farmers with the least acres of land (two acres), lack of training, poor access to credit, and limited market channels. The adoption of purple tea was however positively influenced by factors such as requiring little investment, higher income level, less risk on crop failure, and availability of labor.

Further adaption strategies include selection of the most suitable areas for tea growing, no expansion of new planting or replanting in low production areas, crop diversification in low production areas, efficient management of soil and water resources, catchment protection, riverbank protection, soil water conservation, crop insurance, use of drought tolerant cultivars, rainwater harvesting, and establishment of shade trees. Shade management particularly in the low and mid country reduces ambient temperature and prevents sun scorch. Other benefits of shade trees include carbon sequestration, improved net assimilation of tealeaf, reduced weed growth, additional organic matter from leaf litter and minimized wind damage, reduced frost, and reduced soil erosion (Ethical Tea Partnership 2011; Omondi 2015; Prematilake 2014). Tree planting also reduces frost and prevents soil erosion.

Several key partnerships enable the tea sector to adapt to and mitigate climate change. KTDA is involved in partnerships geared toward sustainable agriculture including climate change adaptation. One of its key partners has been Unilever, which is a multinational corporation with tea estates in Kenya and is also a major buyer of tea sold by KTDA. Unilever established a Sustainable Agriculture Programme in 1999. In 2007, it launched a partnership with the KTDA to enable Kenya’s small-scale tea farmers acquire the certification standard set by the Sustainable Agriculture Network (SAN), which is a global coalition of environmental organizations. Factories and the KTDA trained farmers through Farmer Field Schools and Rainforest Alliance certification. Selected smallholder farmers are



trained and they in turn instruct other farmers. Each lead farmer reaches an additional 300 farmers to ensure compliance with the SAN Standard required for Rainforest Alliance certification. KTDA in partnership with Unilever and IDH (the Dutch Sustainable Trade Initiative) has certified all the factories to the Sustainable Agriculture Network standards. Both farms and factories must meet the necessary requirements to receive Rainforest Alliance certification. By mid-2016, all of Kenya's smallholder tea farmers had met the Rainforest Alliance certification standards, and Unilever's Lipton brand was selling 100%-certified tea. Other major tea brands also began purchasing certified tea (Cameron 2017). The replicability, scale, and local leadership component of this system could serve as a model for developing participatory climate change adaptation plans (Moroge 2012). By March 2019, all 69 KTDA-managed tea factories were Rainforest Alliance certified and 21 tea factories were Fair Trade certified. Other certifications obtained by tea producers and factories included UTZ, Kosher, and Ethical Tea Partnership (ETP) (IISD (International Institute for Sustainable Development) 2019).

This success is attributed to several factors. Key among these is that Unilever, which has a large market share in Kenya, made the decision to purchase only tea that was Rainforest certified. Tea production is linked to global rather than domestic demand, with more than 95% of tea produced in Kenya is exported. Other factors include the strong regulation of the tea sector by the government including the registration and licensing of factories by the Tea Directorate. Kenya's tea industry is also highly concentrated both geographically and structurally with KTDA accounting for 60% of the market. KTDA's structure is highly integrated with strong links between farmers and factories (Cameron 2017). Unilever was also part of the development of the Cool Farm Tool, a calculator of GHG emissions that is freely available for use by farmers. In collaboration with the Kenyan government, it has been using it to quantify carbon within its plantations (Ellis et al. 2013).

The World Bank (WB) is also a key partner in climate adaptation in the tea sector. It announced during the March 2019 Nairobi Summit that an Emission Reduction Purchase Agreement (ERPA) would be signed between the Carbon Initiative for Development (Ci-Dev) trust fund, with WB acting as trustee, and KTDA Power Company Ltd. (KTDA Power). The contract aims to purchase carbon credits from small hydropower plants that provide power to 350,000 smallholder tea farmers and 39 of their regional tea factories in Kenya (Africa Times 2019). ETP, an alliance of tea packers working toward the sustainability of the tea sector, is another key partner. They started work in Kenya in 2010 and implemented a Climate Change Adaptation Program with GIZ, a German development agency. ETP utilized technology developed by its partners, such as Cafedirect Producers' Foundation, which developed a tool called WeFarm, an SMS platform for farmers (Budsock 2015). ETP also created a partnership with ITC and other nongovernmental organizations and founded a project to help farmers in climate change adaptation and mitigation. The program trains farmers and tea factory managers in carbon standards compliance, conservation and management of water, soil conservation, and use of biogas instead of wood. A partner factory, *Makomboki* Tea Factory that was using 2,000 cubic meters of wood per month as fuel for drying tea, changed to alternative energy sources. This

included sawdust, rice husks, biomass, macadamia, and cashew nut shells and briquettes made from sawdust and rice husk. The new initiative saved more than 30,000 trees while lowering operational costs of that factory by 20% (Omondi 2015).

Multilateral partnerships are particularly effective in adaptation strategies. An example is the “Upscaling and Embedding Sustainability for Smallholder Tea Farmers,” which is a collaborative initiative by KTDA Management Services (KTDA-MS), Unilever, and IDH – the Sustainable Trade Initiative. More than 85,000 (about 15% of 560,000 farmers) small-scale farmers had been trained by 2015 on Sustainable Agricultural Practices under a farmer field School (FFS) program (Cameron 2017). Another multilateral collaboration is between Germany, China, and the Food and Agriculture Organization (FAO), which was formed with the aim of promoting sustainable agricultural development and combating climate change in Kenya. This is through a project on carbon-neutral tea value chains. Germany through GIZ has been working with the KTDA, the Ethical Tea Partnership (ETP) among others in an integrated development partnership with the private sector to increase energy efficiency in all the factories to save GHG emissions and increase income of the farmers (Sino-German Center for Sustainable Development 2019). KTDA in 2015 signed a loan for Ksh.5.5 billion for the construction of seven small hydropower projects. The loan agreement was with the International Financial Corporation (IFC) which is a member of the World Bank, in partnership with other organizations including the Global Agriculture and Food Security Program (GAFSP) the French Development Institution (Proparco, the Netherlands Development Finance Company (FMO)). The expected reduction of reduce Kenya’s carbon footprint from using hydropower is approximately 63,000 tons of carbon dioxide equivalent per year. On average, tea factories spend approximately Ksh. 30 million to Ksh. 65 million each per year on electricity (KTDA 2015). The hydropower plants have a total installed capacity of 16 megawatts and will provide captive power generation with the excess energy being sold to the state-owned power company. The farmers provided 35% equity on the loan via green leaf delivery, making it perhaps the first initiative in the world in which a farmer-owned institution is undertaking a renewable energy project of such a scale (IFC 2016).

KTDA Foundation, a nonprofit charity, also engages in environmental sustainability and climate change. Programs under climate change focus on promoting climate change mitigation, adaptation, and resilience building among smallholder tea farmers. In partnership with factories it has established over 31 indigenous, exotic, and fruit tree nurseries. Over 2.4 million trees have been planted in farms, major water catchment areas, and public forests. It is also undertaking an environmental conservation campaign for schools. Farmers are encouraged to adopt clean, renewable energy through promotion of and access to clean and renewable energy such as energy saving stoves, solar lighting products, and biomass. Adaptation measures include planting tea bushes along hill contours to reduce soil erosion. Seedlings from KTDA nurseries (commonly native species) are distributed throughout the local community for planting along farm boundaries, as buffers for waterways and forests, and to create small forest patches on farms. These native trees store carbon, stabilize the tea microclimate, and increase soil fertility. Planting native trees

on steep slopes or degraded lands can also reduce vulnerability to heavy rains or prolonged droughts which creates resiliency to extreme weather. The KTDA is working to secure its own sources of sustainable fuel by acquiring land and encouraging its farmers to grow woodlots. Eucalyptus is commonly planted for fuelwood in the region. However, eucalyptus takes up large amounts of water, and KTDA and Rainforest Alliance are supporting farmers' efforts to replace eucalyptus in buffer zones with indigenous trees.

Although tea is on the "receiving end" of climate change, it also exacerbates it through deforestation. The common processing method of tea used in Kenya is the Cut Tear and Curl method, known as CTC. This involves the tea leaves going through a process of cutting, tearing, and curling, followed by oxidation and drying. The drying is often carried out using wood fuel due to the high price of electricity. Tea manufacturers are, however, gradually utilizing renewable energy alternatives such as electricity generation through micro-hydro plants to reduce energy costs and potentially generate further revenues by selling surplus electricity back to the national grid. Other mitigation measures include the use of biomass waste to power the water boiler systems. Gravity-powered ropeways are used by Finlay's, a multinational company, in some of its tea plantations. The KTDA also requires factories to acquire open land in order to plant seedlings and grow trees as a sustainable source of firewood. This saves money on the purchase of firewood or alternative fuels and could potentially generate revenues from carbon trading if the planted forests are managed sustainably. Varieties of tea other than Black CTC tea undergo a less emission-intensive process, as the wilting and CTC process are not required. Black CTC tea is manufactured by all 69 factories while only ten process black orthodox tea and four process other specialty tea.

---

## Coffee Sector in Kenya

Kenyan coffee is grown on an estimated total area of 115,570 ha in 32 of 47 counties in the country. The sole type of coffee produced in the country is Arabica, which is planted during the rainy season from April to October with two harvest periods, April to June and October to December. Production is enabled by a combination of deep red volcanic soils, high altitude, rainfall, and moderate temperatures. The sole type of coffee grown in Kenya is Arabica. Coffee is grown in the high potential areas between 1,400 and 2,200 m above sea level, with temperature ranging from 15 °C to 24 °C, in red volcanic soils that are deep and well drained. Over 99% of Kenyan coffee is Arabica, whose main varieties are SL 28, SL 34, K7, Ruiru 11, Batian, and Blue Mountain (ICO 2019a). Coffee is an evergreen shrub and is therefore an important contributor to carbon sequestration, effective in stabilizing soils and permits the preservation of much of the original biodiversity in planted areas (ICO 2019b). The coffee sector contributes annually an average of US\$230 million in foreign exchange earnings and is ranked as Kenya's fourth most important export, after horticulture, tourism, and tea. In 2018 coffee earnings amounted to Ksh. 14.8 billion. The value of coffee as a percentage of all export goods represented 5.5% in

2017, while its share of GDP was 0.22%. The coffee industry contributes an average of Ksh. 23 billion per year in foreign exchange earnings, ranking fourth after tourism, tea, and horticulture (ICO 2019a). Coffee is grown on 115,600 ha, 90,000 ha by smallholders and 25,000 ha by estates. Production was 41,400MT with 30,000MT from cooperatives and 11,000MT from estates (KNBS 2019). In 2017/18, the major importing countries of Kenyan coffee were Germany, the USA, Belgium, and the Republic of Korea, who imported about 58% of Kenya's coffee. Thirty-two of the 47 counties in Kenya are coffee producers (ICO 2019a).

Kenya has about 700,000 coffee farmers and about 99.63% have less than five acres. All coffee farmers with less than five acres are mandated to cooperative membership. There are between 500 coffee cooperatives (ICO 2019a) and 651 coffee cooperatives (KNBS 2019). Each coffee cooperative has factories where farmers deliver coffee berries for processing. At the factory, the coffee berries undergo pulping, which is a process of washing and drying, which results in "parchment." Parchment is then delivered to a coffee miller who further processes and grades the coffee, resulting in the "green" or "clean" coffee which is then sold by marketers at the Coffee Exchange through auctioning. Cooperatives also have the option of selling coffee directly to buyers without going through the auction. The Coffee Directorate is mandated to develop, promote, and regulate the coffee industry in Kenya. The Coffee Research Institute (CRI) conducts research in all areas of production, processing, and marketing of coffee. The global organization for coffee is the International Coffee Organization (ICO). It is comprised of member governments who represent 98% of world coffee production and 67% of world consumption. One of its objectives is to encourage members to develop a sustainable coffee sector in economic, social, and environmental terms (ICO 2019b).

## Climate Change Challenges in the Coffee Sector

It is estimated that half the world's coffee-producing land will be unsuitable for coffee production by 2050 (Bunn et al. 2015; CIAT 2011). Other estimates indicate that the area unsuitable for production could be as high as 88% in Latin America (Worland 2018). Climate change caused by changing rainfall patterns and rising temperatures is affecting coffee production in several ways: directly through negative effects on the coffee plant and indirectly by altering the population dynamics and incidence of coffee pests and diseases (Jaramillo 2013). Rising temperatures will especially damage the Arabica bean, which accounts for about two-thirds of global coffee production, but whose production is limited to subtropical highlands in Brazil, Central America, and East Africa (Cameron 2017). This narrow region of the tropics is known as the coffee belt, and stretches from Central America to Sub-Saharan Africa to Asia (Worland, 2018). Rising temperatures will bring drought, increase the range of diseases, and kill large swaths of the insects that pollinate coffee plants (Worland 2018). Recent trends indicate that coffee growing is shifting from traditional optimal growing zones to higher altitudes. In traditional growing zones random flowering patterns and differences in berry growth stages has resulted in

difficulties in disease and pest management, harvesting, and processing (Daily Nation 2012).

The effects of climate change in Kenya include unreliable and erratic rains with shorter seasons (ICO 2019b). Changing rainfall patterns affect the flowering of the coffee plants which impacts the whole production cycle. The altered flowering pattern with coffee berries at different stages of maturity poses a challenge in disease management, insect management, and harvesting (Ethical Tea Partnership 2011; Mugo 2016; Mwaura 2010). Extremely heavy rains lead to higher erosion levels, resulting in loss of soils, leaching of nutrients, and consequent soil infertility. On the other hand, the dynamics of incidence of coffee pests and their management are evolving rapidly due to changing climatic conditions. The changing environment is also posing challenges to patterns of cherry ripening and drying of parchment because of unpredictable rainfall patterns (ICO 2019b). Changing rainfall patterns cause uncertainty regarding the timing of fertilizer application and the drying of parchment. Most coffee growing zones in central Kenya, particularly Kiambu and Murang'a, are no longer suitable for the crop due to rising temperatures (Kamau 2017). Intermittent rainfall in the 2007/08 crop year caused a severe episode of Coffee Berry Disease that cut Kenyan output by 23% to 42,000 MT. This happened because farmers were not able to spray the crop on time (Mwaura 2010). Climate variability and its effects is however not a "new" problem, as evidenced by research shortly after Kenya's independence. This is illustrated by a 1969 journal article by Nutman and Roberts, titled "*Climatic conditions in relation to the spread of coffee berry disease since 1962 in the in the East Rift Districts of Kenya.*" (F.J. Nutman & F.M. Roberts 1969)

## **Adaptation and Mitigation Measures by Small-Scale Farmers in the Coffee Sector**

The Coffee Directorate in collaboration with stakeholders provides capacity building to the counties' agricultural staff and other value chain players. The collaborating private agencies include Technoserve, Solidaridad, certification bodies such as UTZ, 4C, and Fairtrade, and management services providers. CRI develops technologies, releases new coffee varieties, and carries out research on disease and pest management, while the Ministry of Agriculture sets policy guidelines (ICO 2019b). The Coffee Research Foundation (currently CRI) started a program in 2012 to help farmers reverse the effects of global warming and boost coffee production. Farmer sensitization clinics were held and farmers were encouraged to plant indigenous trees to provide shade and to practice water harvesting (Daily Nation 2012). The CRI has made various recommendations on approaches toward environmentally sustainable coffee production systems. One approach is integrated farming, in which mulching, conservation agriculture, organic fertilizers, and use of bio-stimulants are recommended. Other measures include the use of suitable shade trees and the adjustment of spraying programs to cope with changing trends in the manifestation of coffee pests and diseases (ICO 2019a). Most Kenyan coffee is grown without

shade, but shaded coffee is becoming increasingly popular in order to mitigate the effects of climate change, although quantifying the area under shade has not been done. Research is ongoing to determine the appropriate shade trees (ICO 2019a). Research shows that biodiverse shaded coffee is far more resilient and productive than coffee grown in monoculture. Shading coffee therefore improves the resilience of agro-ecosystems. Shade trees protect plants from microclimate variability, the effects of lower precipitation and reduced soil water availability, and reduce high solar radiation. It also improves soil fertility, protects coffee from insect pests, and provides economic benefits for farmers (Jaramillo 2013).

The need to develop disease-resistant coffee varieties was felt in early 1971 and breeding programs were initiated whose optimal outcome was the cultivar Ruiru 11 (Njoroge 1991). The CRI currently has developed two improved varieties of coffee – Ruiru11 and Batian. The improved varieties are resistant to Coffee Berry Disease and Leaf Rust Disease, thus lowering the use of agrochemicals and reducing production costs. The CRI estimated that the production cost of the traditional variety is four to five times more than Ruiru 11 and Batian. Over 300,000 farmers are estimated to have planted the new varieties (ICO 2019a). The traditional variety of coffee grown is SL-28. Other Arabica varieties include SL-34, K7, and Blue Mountain. A study of the coffee sector in Nyeri County showed that 50% of farmers in certified coffee cooperatives and 57% in the noncertified cooperatives had only the traditional SL variety of coffee on their farm. An additional 45% in the certified and 39 per in the noncertified had other varieties in addition to the SL (Okech 2019). It therefore means that less than 5% had the disease and drought resistant varieties exclusively on their farms. Incentives therefore need to be provided to encourage planting of new varieties, beyond the step of providing free seedlings.

The International Coffee Organization (ICO) has pilot projects in Africa and Latin America to address climate change by assisting coffee farmers use environmentally friendly technologies. These include building the capacity of institutions, improving access to credit and risk management mechanisms, reducing vulnerability to income volatility, and promoting gender equality. It also engages in long- and short-term adaptation strategies as well as mitigation strategies (ICO 2019b). Several organizations including private companies involved in coffee production and marketing have taken the lead in climate change adaptation and mitigation in the coffee sector. The World Coffee Research (WCR), a consortium supported by major coffee retailers, distributors, and exporters, has an \$18 million coffee-monitoring program that covers 1,100 farms in 20 countries including Kenya. It conducts farmer training, provides technical assistance, and is testing coffee varieties and adaptive farming methods (Worland 2018). Since 2013 Starbucks has support centers in nine countries and a 10-year, \$500 million investment fund that supports sustainability programs, including adaptation training for farmers and the testing of new coffee varieties (Worland 2018). Sangana Commodities Ltd and GIZ implemented a three-year project creating a link between coffee smallholders and carbon markets, and developing a verifiable and voluntary climate change module, which can be integrated into the existing 4C's standard (ETP 2011).

Sustainability standards in the coffee sector are geared toward sustainable agricultural practices, which include adaptation and mitigation measures. Certification in the coffee sector is, however, not as extensive as in the tea sector. In Nyeri County, which is a leading coffee producer, Fairtrade was the most common certification with at least 12 of the 23 cooperatives having received this certification. The earliest reported Fairtrade certification in the cooperatives was from 2006. At least seven cooperatives had obtained Rainforest Alliance certification and four had acquired 4C certification. Benefits of certification included payment of premiums and improved quality and quantity of coffee. Challenges included difficulty of maintaining certification as it was involving and expensive. This is illustrated by the example of an estimated Ksh. 400,000 for certification and renewal, with additional costs of up to Ksh. 1,000,000. Enforcing requirements as well as nonconformity to requirements was also costly. Certification organizations also did not source for markets and the cooperatives therefore used the conventional marketing channels, which were viewed as opaque (Okech 2019).

---

## Recommendations and Conclusion

Tea and coffee are essential to farmers and other Kenyans as a source of livelihood, to the government as a contributor to GDP and foreign exchange and to the commodity chain players such as marketers and retailers. Tea and coffee also contribute significantly to climate change mitigation. Climate change, however, threatens to disrupt the production of these crops and by extension the economy of Kenya and the livelihoods of those who depend on it. Continued and increased uptake of climate adaptation and mitigation measures is critical for the sustainable farming of tea and coffee. Climate change can worsen the socioeconomic condition of farmers and conversely fragile socioeconomic conditions can exacerbate climate change. Various measures can be taken to increase the adaptive capacity of small-scale tea and coffee farmers.

## Farmer Empowerment

Farmers are rational economic actors and farming has to be profitable for adaptation and mitigation measures to be implemented. Climate adaptation and mitigation activities such as uptake of improved crop varieties are carried out in view of perceived economic benefits and particularly for the most vulnerable, in view of immediate economic benefits. Activities such as the adaptation of improved crop varieties can be neglected due to small land size and the resultant “lost” while the new variety matures to the point of harvest. Other measures such as water harvesting may require capital expenditures whereby the capital is either unavailable or the returns to investment are deemed uneconomical. Interventions that deal with commodity chain weaknesses that reduce profitability are critical. Profitability of farming is the largest incentive to adopting sustainable agricultural practices. Increasing the

adaptive capacity of tea farmers therefore requires farmers' economic empowerment. It is essential that stakeholders provide incentives for the implementation of measures whose returns are long-term or not tangible. This could include measures such as insurance for climate-related crop losses and a minimum guaranteed price per kilogram. Farmers also need to be politically empowered as decisions in farmer organizations are often made by elected representatives. Civic awareness is therefore an integral component of farmer empowerment. Social empowerment majorly revolves around gender. Men predominantly own land but women provide 60% of the labor on the farms and in the wet mills (ICO 2019b). Women therefore need to be major actors in activities involving climate change adaptation and mitigation. When they are not empowered, especially in terms of access to resources, various adaptation and mitigation activities may not be implemented.

## Strengthening of Institutions

The common features of the tea and coffee sector in Kenya is that both are cash crops, grown majorly for export and production is predominantly by small-scale farmers. Profitable production therefore requires that farmers organize so as to share costs. In the tea sector, the KTDA is the primary agency through which farmers produce process and market their tea. In the coffee sector, coffee cooperatives are the primary and mandated vehicle for production, marketing, and processing. However, there are coffee farmers with more than five acres who choose to remain in cooperatives due to economies of scale. Institutional capacity therefore has a large influence on farmers' activities, including those related to climate change adaptation and mitigation. Lack of institutional capacity in farmer-owned organizations or institutions that support farmers can reduce productivity and profits and therefore constrain farmers' adaptive capacity. The average age of tea and coffee farmers is over 50 years and this further constrains the availability of alternative livelihoods. Unlike the tea sector where almost all small-scale tea farmers operate within the institutional structure of KTDA, coffee cooperatives are not homogeneous. For example, coffee payments for the 2017/18 year varied from Ksh. 9 to Ksh. 105/kg of coffee cherry (exchange rate in this period was approximately one USD to Ksh. 100–103). While there are climatic and soil-type differences, the differing payments were also within the same region. In Nyeri County, which is a leading coffee producer, the payment range was between Ksh. 12.75 and Ksh. 105. This points to institutional constraints at the cooperative level, although constraints occur across the coffee commodity chain. The challenges facing the coffee sector are well documented. Toward this end, a Coffee Taskforce was created to investigate the challenges and make recommendations for sectoral improvement. The tea sector has also encountered various institutional challenges. In January 2020, the president directed that the KTDA be restructured for the benefit of tea farmers (Cheruiyot 2020). The organizations that farmers engage in and the institutions within which they operate can either facilitate or constrain the activities of farmers, including those pertaining to climate change adaptation and mitigation.



## Collaborations and Partnerships

Climate change adaptation and mitigation requires the long-term involvement of all actors in the commodity chain including the consumers. Stakeholder mapping is necessary, whereby a list of relevant groups, organizations, and people who can collaborate in climate change adaptation and mitigation can be invited to collaborate towards these measures. These stakeholders include the International Coffee Organization, the Tea and Coffee directorates, agricultural institutions and departments, producer organizations, certification organizations, technical support providers, financial institutions, and supply chain actors including processors, marketers, and retailers. Research, information, and best practices on sustainable agricultural practices and on measures to streamline the commodity chain can be enhanced and widely adopted through collaboration.

## Certification

The 2017 SAN Standard aims to support farmers in advancing sustainable livelihoods, improving farm productivity, and becoming more resilient to climate change. Changes of note include climate-smart agricultural practices. These are built into the standard to help farmers address climate change risks. The effect of irregular rainfall, changing temperatures, and related increased pest and disease attacks can be reduced through soil conservation, water-use efficiency, and the conservation and restoration of natural ecosystems. The Standard is built on principles of sustainable farming including biodiversity conservation, improved livelihoods and human well-being, natural resource conservation, effective planning, and farm management systems (Rainforest Alliance 2019). The SAN Climate Module is an add-on for voluntary verification within the existing Sustainable Agriculture Network certification system. Farmers who achieve compliance with the module will be able to assess the risks posed by climate change to their farms and communities, analyze their practices to quantify and reduce GHG emissions, and increase the carbon levels stored on their farms through the restoration of degraded lands, reforestation, and improved soil conservation while also being able to better adapt to altered growing seasons and other conditions (Sustainable Agriculture Network 2011).

Fairtrade aims to help farmers become more resilient to climate change while giving consumers, retailers, and traders the opportunity to reduce their carbon footprint. Farmers can spend the Fairtrade Premium on climate change adaptation projects such as tree planting, irrigation, crop diversification, and clean energy. Farming communities can also benefit from access to carbon finance, which can be used in mitigation or adaptation activities (Fairtrade International 2015). While certification has numerous benefits, acquiring and maintaining of certification by coffee cooperatives and estates requires the collaboration and financial support of stakeholders.

Rainforest Alliance and Fairtrade are the major certification bodies in the coffee and tea sector in Kenya. Majority of the small-scale tea farmers in Kenya comply with the SAN Standard and have received Rainforest Alliance. This extensive

certification can be largely attributed to the institutional arrangement of the tea sector. KTDA acts as the management agent for 69 factories, which comprise the vast majority of small-scale tea farmers in Kenya. In the coffee sector, however, more than 700,000 farmers are members of an estimated 500–650 coffee cooperatives. Certification depends on various factors including membership numbers, productivity levels, number of factories, cooperative leadership, and relationships with a multiplicity of commodity chain actors. While some cooperatives are certified by multiple certification bodies, others do not comply with any sustainability standard. Certification ensures the implementation of climate change adaptation and mitigation measures. Acquiring and complying with sustainability standards is therefore key for small-scale farmers.

---

## References

- Africa Times (2019) World Bank commits \$22.5 billion more to Africa for climate change. Africa Times. Retrieved 10 Dec 2019 from <https://africatimes.com/2019/03/15/world-bank-commits-22-5-billion-more-to-africa-for-climate-change/>
- Budsock A (2015) Ethical tea partnership – adapting smallholders to climate change. Retrieved 10 Dec 2019 from <https://impakter.com/ethical-tea/>
- Bunn, Laderach, Rivera and Kirschke (2015) A bitter cup: climate change profile of global production of Arabica and Robusta coffee Climate Change 129:89–101
- Cameron B (2017) Brewing a sustainable future: certifying Kenya’s smallholder tea farmers, 2007–2017. Woodrow Wilson School of Public and International Affairs, Innovations for successful societies. Princeton University. Retrieved 10 Dec 2019
- Change K (2015) World tea production and trade current and future development, Food and agriculture organization, trade and markets division. FAO, Rome
- Cheruiyot K (2020) Uhuru orders for KTDA restructuring to save tea farmers. The Star. Retrieved 22 Jan 2020 from <https://www.the-star.co.ke/news/2020-01-14-uhuru-orders-for-ktda-restructuring-to-save-tea-farmers/>
- Daily Nation (2012) New plan to help farmers reverse effects of climate change. Daily Nation. Kenya. Retrieved 10 Dec 2019 from <https://reliefweb.int/report/kenya/new-plan-help-farmers-reverse-effects-climate-change>
- East Africa Tea Trade Association (2020) Tea care and husbandry management. Retrieved from [eatta.com](http://eatta.com)
- Ellis K, Lemma A, Mutimba S, Wanyoike R (2013) Low carbon competitiveness in Kenya. Policy brief, Overseas Development Institute. Retrieved 17 Jan 2020
- Ethical Tea Partnership (2011) Climate change adaptation in the Kenyan tea sector. Report from the adaptation workshop held in Kericho on the 16th of May 2011. Retrieved from [ethicalpartnership.org](http://ethicalpartnership.org)
- Fairtrade International (2015) Climate change. Retrieved 2020 from [fairtrade.net](http://www.fairtrade.net): <https://www.fairtrade.net/issue/climate-change>
- FAO (Food and Agricultural Organization) (2020) Kenya at a glance. Retrieved from [www.fao.org](http://www.fao.org): <http://www.fao.org/kenya/fao-in-kenya/kenya-at-a-glance/en/>
- FAO (Food and Agriculture Organization of the United Nations) (2015) Kenya’s tea sector under climate change. An impact assessment and formulation of a climate-smart strategy, by Elbehri A, Cheserek B, Azapagic A, Raes D, Mwale M, Nyengena J, Kiprono P, Ambasa C. Rome, Italy
- Government of Kenya (2015) Addressing climate change: success stories from Kenya. Ministry of Environment, Natural Resources and Regional Development Authorities. Government of Kenya. Retrieved 17 Jan 2020

- Government of Kenya (2010) National climate change response strategy. Executive Brief. Retrieved from environment.go.ke: <http://www.environment.go.ke/wp-content/documents/complate%20ncrcs%20executive%20brief.pdf>
- IFC (2016) Kenya's tea farmers taste benefits of hydropower. International Finance Corporation. Retrieved 9 Mar 2020 from ifc.org: [https://www.ifc.org/wps/wcm/connect/news\\_ext\\_content/ifc\\_external\\_corporate\\_site/news+and+events/news/impact-stories/tea-farmers-taste-the-benefits-of-hydropower](https://www.ifc.org/wps/wcm/connect/news_ext_content/ifc_external_corporate_site/news+and+events/news/impact-stories/tea-farmers-taste-the-benefits-of-hydropower)
- IISD (International Institute for Sustainable Development) (2019) Sustainability and voluntary certification in the Kenyan tea sector. Developing an action plan to address opportunities and challenges. Report of the Meeting Held in Nairobi, Kenya, March 6, 2019. Retrieved 29 Apr 2020 from [iisd.org](http://iisd.org)
- International Coffee Organization (2019a) Country coffee profile: Kenya. International Coffee Organization. International Coffee Council. Retrieved 17 Jan 2020 from <http://www.ico.org/documents/cy2018-19/icc-124-7e-profile-kenya.pdf>
- International Coffee Organization (2019b) Developing a sustainable coffee economy. Retrieved 17 Jan 2020 from [http://www.ico.org/sustaindev\\_e.asp](http://www.ico.org/sustaindev_e.asp)
- International Trade Center (2014) Mitigating climate change in the tea sector. ITC, Geneva. Retrieved from: [intracen.org](http://intracen.org) on 17 Jan 2020
- Jaramillo JSM-O (2013) Climate change or urbanization? Impacts on a traditional coffee production system in East Africa over the last 80 years. (Hart JP, ed). PLoS ONE 8(1). Retrieved 17 Jan 2020 from <https://journals.plos.org/plosone/article?id=10.1371/journal.pone.0051815>
- KALRO (2020) Purple tea. Retrieved from [kalro.org](http://www.kalro.org): <http://www.kalro.org/tea/?q=Purple%20Tea>
- Kamau G (2017) Coffee takes beating from rising global temperature. The East African. Retrieved 17 Jan 2020 from <https://theeastafrican.co.ke/business/climate-change-effect-on-coffee/2560-3998982-giionx/index.html>
- Kenya National Bureau of Statistics (KNBS) (2019) Economic survey 2019. Economic survey, Kenya National Bureau of Statistics. Retrieved 10 Dec 2019 from [www.knbs.or.ke](http://www.knbs.or.ke)
- Kenya Tea Growers Association (KTGA) (2016) Kenya tea growers association. Retrieved 23 Apr 2020 from Kenya Tea Growers Association: [ktga.or.ke](http://ktga.or.ke)
- Kimtai R (2019) Adoption of purple tea farming as a coping mechanism to climate variability and change. A case study of Kericho County, Kenya. Masters thesis, Jomo Kenyatta University of Agriculture and Technology, Environmental Legislation and Management. Retrieved 17 Jan 2020
- KTDA (2015) KTDA Signs Ksh. 5.5 Billion loan agreement to construct seven small hydropower projects. Retrieved 9 Mar 2020 from [ktdateas.com](http://ktdateas.com): <https://www.ktdateas.com/index.php/blogs/item/49-ktda-signs-ksh-5-5-billion-loan-agreement-to-construct-seven-small-hydropower-projects.html>
- Ministry of Agriculture, Livestock and Fisheries (2020) Towards sustainable agricultural transformation and food security in Kenya 2019–2029. Government of Kenya. Retrieved 10 Mar 2020 from <http://www.kilimo.go.ke/wp-content/uploads/2019/01/ASTGS-Full-Version.pdf>
- Moroge M (2012) In Kenya, tea growers adapt to climate change. Retrieved 10 Mar 2020 from [rainforest-alliance.org](http://rainforest-alliance.org): <https://www.rainforest-alliance.org/pictures/kenya-tea-growers>
- Mugo I (2016) Global warming takes its toll on coffee production. Daily Nation. Kenya. Retrieved 10 Dec 2019 from <https://www.nation.co.ke/news/Global-warming-takes-its-toll-on-coffee-production/1056-3461704-avbq99z/index.html>
- Mwaura HN (2010) Climate change affecting Kenya's coffee output. Retrieved 10 Dec 2019 from <https://www.reuters.com/article/us-kenya-coffee-climate/climate-change-affecting-kenyas-coffee-output-idUSTRE61A0WA20100211>
- National Environmental Management Authority (2020) Environmental Act (EMCA). Retrieved from [nema.go.ke](http://www.nema.go.ke): [http://www.nema.go.ke/index.php?option=com\\_content&view=article&id=24&Itemid=163](http://www.nema.go.ke/index.php?option=com_content&view=article&id=24&Itemid=163)
- Ngumo D (2015) My experience in the tea sector. Retrieved from [karuspace.karu.ac.ke](http://karuspace.karu.ac.ke)
- Njoroge J (1991) Management of hybrid Ruiru 11 [eleven] Arabica coffee – a review. Coffee Research Foundation, Ruiru. Retrieved 10 Dec 2019 from [www.kainet.ne.ke/documents/management-hybrid-ruiru-11-eleven-arabica-coffee-review-1](http://www.kainet.ne.ke/documents/management-hybrid-ruiru-11-eleven-arabica-coffee-review-1)

- Nutman FJ, Roberts FM (1969) Climatic Conditions in Relation to the Spread of Coffee Berry Disease Since 1962 in the East Rift Districts of Kenya. *East African Agricultural and Forestry Journal* 35 (2):118–127
- Okech AN (2019) Producer institutional arrangements in Kenya's coffee sector and their effect on economic benefits to farmers. PhD thesis. Department of Development Studies. Jomo Kenyatta University of Agriculture and Technology, Juja
- Omondi D (2015) Climate change bites Kenyan tea farmers. *Voices2Paris*. Retrieved 10 Dec 2019
- Prematilake K (2014) Climate change adaptation strategies for tea plantations. Tea Research Institute of Sri Lanka, Agronomy Division. Retrieved 17 Jan 2020
- Rainforest Alliance (2019) What does rainforest alliance certified mean? Retrieved 11 Mar 2020 from [rainforest-alliance.org: https://www.rainforest-alliance.org/faqs/what-does-rainforest-alliance-certified-mean](https://www.rainforest-alliance.org/faqs/what-does-rainforest-alliance-certified-mean)
- Republic of Kenya (2016) The climate change act, 2016. Kenya gazette supplement. Government Printer, Nairobi
- Republic of Kenya (2018) National climate change action plan 2018–2022. Ministry of Environment and Forestry. Government of Kenya
- Sino-German Center for Sustainable Development (2019) Carbon-neutral tea value chains – Germany, China and the FAO Join Forces with Kenya. Retrieved 9 Mar 2020 from <https://sg-csd.org>: [https://sg-csd.org/news\\_events/20190328/](https://sg-csd.org/news_events/20190328/)
- Sustainable Agriculture Network (2011) SAN climate module criteria for mitigation and adaptation to climate change. Retrieved from [www.rainforest-alliance.org: https://www.rainforest-alliance.org/lang/sites/default/files/site-documents/climate/documents/SAN-Climate-Module-January2011.pdf](http://www.rainforest-alliance.org/lang/sites/default/files/site-documents/climate/documents/SAN-Climate-Module-January2011.pdf)
- UNDP (2020) Climate change adaptation. Kenya. Retrieved from [adaptation-undp.org](http://adaptation-undp.org)
- USAID (2018) Climate risk profile Kenya. Retrieved from: [climatelinks.org](http://climatelinks.org) on 17 Jan 2020
- Worland J (2018, July 2) Your morning cup of coffee is in danger. Can the industry adapt in time? TIME. Retrieved 17 Jan 2020 from <http://time.com/5318245/coffee-industry-climate-change/>

**Open Access** This chapter is licensed under the terms of the Creative Commons Attribution 4.0 International License (<http://creativecommons.org/licenses/by/4.0/>), which permits use, sharing, adaptation, distribution and reproduction in any medium or format, as long as you give appropriate credit to the original author(s) and the source, provide a link to the Creative Commons license and indicate if changes were made.

The images or other third party material in this chapter are included in the chapter's Creative Commons license, unless indicated otherwise in a credit line to the material. If material is not included in the chapter's Creative Commons license and your intended use is not permitted by statutory regulation or exceeds the permitted use, you will need to obtain permission directly from the copyright holder.





# Adaptive Capacity to Mitigate Climate Variability and Food Insecurity of Rural Communities Along River Tana Basin, Kenya

David Karienyé and Joseph Macharia

## Contents

Introduction .....	50
Impacts of Climate Variability .....	52
Adaptive Capacity to Mitigate Climate Variability Impacts .....	54
Impacts and Adaptation Strategies to Climate Variability in Arid and Semi-arid Lands: A Case of Garissa and Tana River Counties in Kenya .....	54
Rainfall and Temperature Impacts on Food Security .....	54
Community Perception on Climate Variability and Its Impacts .....	55
Adaptation Strategies to Climate Variability in Arid and Semi-arid Land .....	57
Conclusions .....	57
Recommendations .....	58
References .....	58

## Abstract

Climate variability is one of the leading natural threats and a root cause of food insecurity in the developing world, more so in Africa. It is a major impediment to the accomplishment of the global Sustainable Development Goals (SDGs), Vision 2030 and Big Four agenda in the Kenyan context. The rise in occurrence and brutality of extreme events resulting from variability of climate including prolonged flooding and drought has become more pronounced in the relatively

This chapter was previously published non-open access with exclusive rights reserved by the Publisher. It has been changed retrospectively to open access under a CC BY 4.0 license and the copyright holder is “The Author(s)”. For further details, please see the license information at the end of the chapter.

D. Karienyé (✉)

Department of Geography, Garissa University, Garissa, Kenya

J. Macharia

Department of Geography, Kenyatta University, Nairobi, Kenya

© The Author(s) 2021

W. Leal Filho et al. (eds.), *African Handbook of Climate Change Adaptation*,  
[https://doi.org/10.1007/978-3-030-45106-6\\_57](https://doi.org/10.1007/978-3-030-45106-6_57)

drier areas. This chapter presents a synthesis about rural communities in Garissa and Tana River Counties, Kenya. The key environmental conditions that face the rural communities in the two counties are prolonged drought and recurrent flooding events. The two conditions have resulted in various challenges facing the communities in these regions through low agricultural production (food and pastures), poor infrastructure, human displacement, and the resultant extreme poverty, overall food insecurity, and tough livelihoods. The problems have been exacerbated by lack of capacity by most of the community members to cushion themselves against these impacts. However, as the conditions continue to manifest themselves, the community members have also identified adaptive mechanisms that are best suited in the region including planting drought-resistant crop varieties, diversifying their livelihoods, embrace sustainable land use, and made efforts to plant trees. We, therefore, conclude that integrated information sharing including early warning alongside affordable and appropriate technologies and crop insurance could be an entry point in cushioning the local communities in the arid and semiarid lands (ASALs) against the extreme weather conditions experienced in the region.

---

**Keywords**

Adaptive capacity · Africa · Climate variability · Food insecurity · Mitigation · Rural livelihoods

---

**Introduction**

Climate variability has been on the rise due to increased global atmospheric greenhouse gas emissions (GHG) comprising mainly of nitrous oxide, carbon dioxide, and methane (IPCC 2014). Carbon dioxide is the key GHG, while as much as methane and nitrous oxide are emitted in trivial quantities in reference to carbon dioxide, they play a significant role in global warming and their associated global effects. For example,  $N_2O$ , a potent gas with a high potential to deplete ozone layer, is over 265 more powerful while  $CH_4$  is 28 more powerful in their global warming potential relative to carbon dioxide, over 100 years' time limit (IPCC 2014). These three main GHGs accounts more than 80% to the present global radiative imposing to enhanced global warming and consequently climate variability and its negative resultant effects (Myhre et al. 2013).

Climate variability characterizes one of the extreme economic, environmental, and social intimidations facing the earth presently (Nnadi et al. 2019). In emerging countries, climate variability has a substantial influence on the livelihoods and living situations of the rural communities. Sub-Saharan Africa (SSA) is a “vulnerability hot spot” of climate variability influences (Asfaw et al. 2018). SSA challenges on adaptation will raise considerably, even if the global emission gap is maintained lower than 2 °C due to limited adaptive capacity. The IPCC's Fourth Assessment (AR4) demonstrated that Africa's vulnerability to the effects of climate variability is

relatively high due to low adaptive capacity and over-reliance on natural systems for their livelihoods (Mpandeli et al. 2019). Extreme occurrence of droughts is likely to become more rampant and severe in Africa (Schellnhuber et al. 2012). Consequently, climate variability is negatively affecting agricultural production, particularly in SSA where most countries rely heavily on rainfed agriculture as the mainstay of their economies (Abdul-Razak and Kruse 2017). Climate variability related to biophysical stressors is expected to worsen the existing vulnerabilities by dipping the crop yields (González-Orozco et al. 2020).

It is postulated that warming more than 3 °C worldwide will see almost all of the current crops such as maize, sorghum, and millet-cultivated regions in Africa becoming unfeasible for present cultivars. Water unavailability, lower feed quality which is inaccessible, and effects of disease and heat stress will negatively affect production in the livestock sector (Schaeffer et al. 2013). According to Huq et al. (2004), climate variability has a direct impact on how humans manage natural resources and which results in food insecurity. The risks associated with climate variability threaten the capacity of livelihoods to meet basic needs, such as food and water. These effects will be more intense in the arid and semiarid lands (ASALs) where the resources are already limited, vulnerable, and could, therefore, suffer the most.

To mitigate climate variability, community adaptive capacity must be pursued. According to Levina and Tirpak (2006), the term adaptive capacity has been defined differently by different authors. Different authors have explained the concept of adaptive capacity to simply mean the capacity of a natural system to positively respond to the impacts of climate variability. Policymaker also use the term adaptive capacity to refer to the ability of individual communities to respond and adjust their way of life based on the effects of climate variability and lead to adaptation. Therefore, whenever we use adaptive capacity, society and communities must come up with coping strategies especially when dealing with impacts of climate variability in order to minimize its adverse effects.

Communities living in SSA are facing climate variability in a very tough way due to their lack of capacity to respond. The influences include increasing temperatures, more inconsistent rainfall, and increasing incidence of floods and droughts (CARE and ALP 2013). These impacts have severe consequences especially among the rural poor whose livelihoods are directly pegged on the very vulnerable environment. These communities heavily depend on land resources for agricultural production and therefore the impacts of climate variability have a direct impact on their livelihoods. Crop yields will decline transversely in the landmass as ideal growing temperatures are surpassed and growing periods reduced. The areas and timing of cropping activities that were previously suitable for certain crop are anticipated to shift as home-grown climates varies.

In Kenya, the adverse effects of climate variability have also been witnessed particularly in the ASALs which forms ~80% of Kenyan land mass (582,646 km<sup>2</sup>) (Macharia et al. 2020). The main effects of climate variability in Kenya have been demonstrated by prolonged and frequent droughts, floods, resurgence of diseases, pests, and environmental disasters. As a result, agricultural productivity is significantly reduced, resulting to increased food insecurity and threatened livelihoods which in

most instances leads to human conflicts over scarce land and water resources (Enya et al. 2013). For instance, the *La Nina* occurring between 1999 and 2001 in SSA was the most prolonged and most severe ever, causing devastating effects especially on human livelihoods. The drought affected over four million people due to crop failure and the resultant reduced yields. Droughts have caused starvation, loss of life, and degradation of the environment as a result of deforestation.

Variability in climate poses major threats to environmental sustenance, commercial, and sustainable development in rural areas of the arid regions of Kenya. In particular, the ASAL region of Garissa and Tana River County has been experiencing severe prolonged drought and flooding despite having River Tana traversing the region. This has led to loss of vegetation cover, drying of water catchment areas, rivers, and seasonal streams. This is then followed by heavy lack of pastures and shortage of drinking water resulting to livestock deaths. Recently, in short rains of 2018/2019, Garissa and Tana River counties experienced floods which caused severe havoc resulting to over 50 fatalities, over 15,000 people displaced, and thousands of livestock killed as a result of bursting of River Tana's banks. In addition, extreme weather events such as flooding has spoiled or destroyed transport and communication networks and affected other nonagricultural portions of the food system badly. This has led the communities to seek alternative ways of meeting their livelihoods such as charcoal burning hence environmental degradation resulting to double tragedy from the loss of their only source of livelihood and land degradation. Against this backdrop, this study aimed to close the gap by identifying possible adaptive capacity of the vulnerable communities in the region for the purpose of coping mechanism. This study was conceived to explore the existing adaptive capacity which is sustainable and viable and which the communities would easily embrace to act as adoptive buffer towards the impacts of climate variability in Garissa and Tana River Counties.

## Impacts of Climate Variability

Key among the impacts of climate variability includes the following.

### (a) Drought

Drought is a major threat globally and more so in Africa due to low adaptation capacity resulting from limited resources. Drought results in decreased moisture emanating from inadequate and erratic rainfall and high extreme temperatures. As observed by Keya (1997), moisture storage is largely dependent on rainfall received prior to the onset of drought conditions and the permeability of the soil (micro edaphic conditions). Drought has led to loss of pasture for the livestock as well as wildlife, vegetation loss, and food insecurity. This threatens the source of livelihoods of local communities in the arid lands.

### (b) Loss of biodiversity

Ecosystem varieties will hypothetically change rapidly as heating increases with reduced precipitation, and will result to biodiversity loss. Some species may be impotent to adapt to the varying climatic conditions (Schaeffer et al. 2013).



High temperatures and lack of precipitation affects distribution and abundance of fauna and flora species. Substantial shifts in climatic situations could result to loss of some standing biomes and the general aesthetic appeal of our environment (Williams et al. 2007). In some instances, the changes in climate may favor the growth of invasive plant species hindering the alien species such as *Prosopis Juliflora* “Mathenge” a common plant in the northern Kenya.

(c) **Food insecurity**

Extreme temperatures above the ideal may have harmful consequences on crop productivity (Wheeler et al. 2000). These changes have a significant effect on the facets of food security since they negatively affect food availability, access, and utilization resulting to unstable and unreliable food systems. Kenya may experience reduced yields with the changing climate (Herrero et al. 2010). Crop yields are drastically reducing in SSA as the optimal temperature increases altering cropping and seasonal calendars (Schaeffer et al. 2013). In Africa and to a large extent, the ASALs region of East African such as Sudan, Ethiopia, and Kenya have in the past experienced hostile climate change. This has hampered crop production leading to acute shortage of food, pastures, and fibers, hence food insecurity. According to Lobell et al. (2011), yields are likely to diminish by ~1% daily for maize crops if such high-temperature regimes are consistent similar with other crops such as cotton and soybeans (Schlenker and Roberts 2009). Similarly, livestock production will be severely affected through quality feed and water availability (Schaeffer et al. 2013).

(d) **Human health and diseases outbreak**

Water availability and increased rates of disease outbreak are transformed by climate change (Schaeffer et al. 2013). The impacts of climate variability will be felt through increased infectious diseases which are relatively high in SSA. Extreme weather events may lead to illness and mortality. The level of malfunction may also be on the rise up to between 35% and 80% due to a rise of between 1.2 °C and 1.9 °C (Lloyd et al. 2011). As reported by Patz et al. (2008), flooding results to disease outbreaks including diarrhea, cholera, trachoma, and conjunctivitis. Other diseases like malaria may shift and be felt to areas where they were not felt before due to changes in temperature suitability responsible for pathogen growth.

(e) **Water resources**

Change in the hydrological sequence due to climate variability has a direct impact on water timing and circulation (Goulden et al. 2009). With most of the countries in SSA facing challenges with provision and supply of clean usable water, climate change will exacerbate this and lead to more water shortages in the coming years (Schellnhuber et al. 2012). The resultant effect will be increased disease outbreaks due to poor sanitation, low agricultural production, food insecurity, and general influence on livelihoods. Rise in temperature due to global warming would lead to a complex rate of evapotranspiration leading to increased loss from water bodies (Ogolla et al. 1997).

(f) **Land degradation**

Population increase combined climate variability impedes good resource management leading to environmental degradation (UNEP 2002b). Climate

variability is slowly encroaching and engulfing countries thus rendering their land unproductive due to variations in weather patterns and global warming. As human population grows further, the natural distribution of vegetation on earth will be altered. This leads to opening new land for agriculture and cultivation of marginal areas (UNEP 2002a). This has led to loss of natural habitats, reducing vegetation cover and exposing soils to wind and water erosion in many parts of Africa. Soil erosion has increased the rate of siltation in dams and rivers and at the same time reducing the productivity of the land.

## **Adaptive Capacity to Mitigate Climate Variability Impacts**

Adaptive capacity calls for strategies to help the communities to adapt to these extreme events such as drought and flooding. Adaptation simply means adjustments made in the existing systems as a response mechanism toward countering the effects of climate variability by the communities and individuals involved. These adjustments are mainly meant to act as a buffer and to assure proper exploitation of the new opportunities that minimize harm and as they present themselves. Therefore understanding the adaptive capacity by farmers is crucial to effective adaptation planning since it assures continuous production crucial to effective planning and guarantees human survival (Chepkoech et al. 2020). With the projected increase in global temperature, likely to result to increase in global warming, it's thus inevitable for individuals and communities to find adaptive ways which guarantees their survival. Adaptive measures toward climate change are no longer regarded as second measured but should be taken as primary consideration especially by farmers. However, the adaptation capacity in most African countries is low mainly due to lack of capacity to invest in the recent technologies which have been studied and found to promote better survival and livelihoods. Majority of agriculture in SSA is rainfed with only a very small percentage of farmers with a capacity to carry out irrigation which makes it difficult to predict due to climate variability. Further, the challenges are associated with lack of reliable weather data to inform on policy, and therefore most of the countries lack early warning systems that can be used early enough to caution the governments of possible climate-related calamities.

---

## **Impacts and Adaptation Strategies to Climate Variability in Arid and Semiarid Lands: A Case of Garissa and Tana River Counties in Kenya**

### **Rainfall and Temperature Impacts on Food Security**

From a data synthesis on annual rainfall and temperature over a period of 20 years for Garissa and Tana River counties indicate that rainfall was characterized with extended dry season occurring between January and February. The long rainy season occurs between March and May (MAM) while prolonged dry season occurs from



**Fig. 1** Reduced River Tana flow during the month of October. (Courtesy of D. Karienyé)

mid-May to mid-October, while short rainy season begins in mid-October to end of December of each year. There are fewer days of more intense rainfall with the rains often starting late but intense which are described as “very unreliable” (that is seasonal failures are common).

Similarly, for temperatures, the highest temperature amounts were observed between February and March, which coincides with the same time when rainfall is lowest in the study area. Around September–October, the temperatures are also at highest. Temperature increase has an important impact on water availability, thus aggravating drought conditions. Decreases in rainfall have profound repercussions on river flows leading to declining river discharge (Fig. 1). The months that saw an increased rise in temperature also experienced drought. This can be explained by the high evapotranspiration making the vegetation deficient of moisture leading to crop and pasture failure.

However, in trying to escape the droughts, the few well-endowed farmers practiced drip irrigation and greenhouse farming as indicated in Fig. 2. This ensured a reduction in the impact of droughts. This low number of farmers adopting new farming mechanisms, and which is a shift from rainfed agricultural production can be explained by the high cost of the greenhouses’ infrastructures. This represents an innovative technology in response to the changing weather patterns though the adoption rates remain relatively low due to high cost.

### **Community Perception on Climate Variability and Its Impacts**

From the interaction with the community, majority of the households were extremely worried about climate variability and identified rainfall to be very unpredictable



**Fig. 2** Farmers practicing greenhouses and drip irrigation. (Courtesy of D. Karienyé)



**Fig. 3** Land degradation through charcoal burning. (Courtesy of D. Karienyé)

stating that there exists a consistently prolonged dry period every now and then. Nevertheless, farmers believe that temperatures have already increased and precipitation has declined or is unpredictable (Karienyé et al. 2019).

The impact of climate variability has been felt mainly by reduced crop production, extreme cases of flooding, and land degradation as evident by charcoal burning (Fig. 3) and reduced biodiversity. The reduced precipitation coupled with flooding leads to crop failure which destroys the crops that are grown along River Tana. Floods have in the past been responsible for causing disruption in transport systems and displaced residents living in the low-land areas which are prone to flooding (CARE and ALP 2013).



**Fig. 4** Community-based agro forestry programs. (Courtesy of J. Macharia)

## **Adaptations Strategies to Climate Variability in Arid and Semiarid Land**

Based on their own experiences and from sharing information among themselves, most of the households in these ASALS of Kenya have identified several adaptive strategies to cushion them against the extreme conditions. The communities preferred livelihood diversification (business, cropping, and livestock) as an alternative livelihood option, sustainable use of the land including conservation agriculture, mulching, building trenches and ditches around the homesteads and watering crops using cans during dry spell. They have also adopted drought-tolerant and early maturing crop species, changing eating behaviors and afforestation (Fig. 4).

---

## **Conclusions**

From our synthesis, the rainy seasons are no longer predictable thereby prohibiting any farming activities. The impacts of climate variability in the ASALS are mainly through extreme conditions of drought and flooding. The two conditions have resulted to various challenges facing the communities in these regions through low agricultural production (food and pastures), poor infrastructure, population displacement resulting to extreme poverty, overall food insecurity, and tough livelihoods. These challenges are exacerbated further by the inability of the majority of the communities to cushion themselves against the impacts of climate variability and this becomes a cyclic problem year in year out. The better-endowed community members have invested in greenhouses and drip irrigations to ensure continuous

supply of food particularly for their domestic consumptions. However, efforts by the local communities have been identified where they have, through experience over time, resulted to planting drought-resistant crop varieties, diversified their livelihoods, embraced sustainable land use, and made efforts to plant trees. It's imperative to note that well-informed, adaptive, and forward-looking decision making is central to adaptive capacity of the host communities. In order for community to respond to expected changes and to participate in adaptive decision-making, they require precise information, knowledge and skills that enable them to actively address climate risks to their livelihoods. Therefore, adaptation energies must aim to ease access to information and the development of the skills and knowledge needed for accurate adaptation targeting. Institutions and agencies responsible for policy formulation should ensure an enabling atmosphere for local adaptation efforts.

---

## Recommendations

In order to embrace the adaptive capacity as long-term practical solutions, the following are recommended:

- Monitoring daily weather patterns and improving scientific understanding of climate.
- The community needs to be trained on affordable and appropriate technologies such as sustainable agriculture.
- Promotion of climate-smart crops farming.
- Promotion of insurance services against the consequences of catastrophic weather events to mitigate against climate variability.
- Provision of early warning systems to the communities.
- There is a need to build community-based capacities in planning, coordination, and implementation of climate change adaptation activities and programs.
- Intensification of tree planting through community-owned nurseries, establish green zones, and invest in reforestation programs.

---

## References

- Abdul-Razak M, Kruse S (2017) The adaptive capacity of smallholder farmers to climate change in the Northern Region of Ghana. *Clim Risk Manag* 17:104–122. <https://doi.org/10.1016/j.crm.2017.06.001>
- Asfaw A, Simane B, Hassen A, Bantider A (2018) Variability and time series trend analysis of rainfall and temperature in northcentral Ethiopia: a case study in Woleka sub-basin. *Weather Clim Extrem* 19:29–41. <https://doi.org/10.1016/j.wace.2017.12.002>
- CARE, ALP (2013) Climate change vulnerability and adaptive capacity in Garissa County. Care International and Adaptive Learning Program (ALP), p 20. [http://www.careclimatechange.org/files/CVCA\\_Kenya\\_Report\\_Final.pdf](http://www.careclimatechange.org/files/CVCA_Kenya_Report_Final.pdf)
- Chepkoech W, Mungai NW, Stöber S, Lotze-Campen H (2020) Understanding adaptive capacity of smallholder African indigenous vegetable farmers to climate change in Kenya. *Clim Risk Manag* 27:100204. <https://doi.org/10.1016/j.crm.2019.100204>

- Enya D, Niversity K, Enya H (2013) National implementing entity – NEMA – Kenya programme, proposal programme title: integrated programme to build resilience to executing entities, October 2013 (Feb)
- González-Orozco CE, Porcel M, Alzate Velásquez DF, Orduz-Rodríguez JO (2020) Extreme climate variability weakens a major tropical agricultural hub. *Ecol Indic* 111:106015. <https://doi.org/10.1016/j.ecolind.2019.106015>
- Goulden M, Conway D, Persechino A (2009) Adaptation to climate change in international river basins in Africa: a review. *Hydrol Sci J* 54(5):805–828
- Herrero M, Ringler C, van de Steeg J, Thornton P, Zhu T, Bryan E, Omolo A, Koo J, Notenbaert A (2010) Climate variability and climate change and their impacts on the agricultural sector. ILRI report to the World Bank for the project “adaptation to climate change of smallholder agriculture in Kenya”. International Livestock Research Institute (ILRI), Nairobi
- Huq S, Reid H, Konate M, Rahman A, Sokona Y, Crick F (2004) Mainstreaming adaptation to climate change in least developed countries (LDCs). *Clim Pol* 4(1):25–43
- IPCC (2014) Summary for policymakers. In: Edenhofer O, Pichs-Madruga R, Sokona Y, Farahani E (eds) Climate change 2014: mitigation of climate change. Contribution of working group III to the fifth assessment report of the Intergovernmental Panel on Climate Change. Cambridge University Press, Cambridge, UK
- Karienyé D, Nduru G, Kamiri H (2019) Socioeconomics determinants of banana farmers perception to climate change in Nyeri County, Kenya. *J Arts Humanit* 8(8):89–101
- Keya GA (1997) Environmental triggers of germination and phenological events in an arid savannah region of northern Kenya. *J Arid Environ* 37:91–106
- Levina E, Tirpak D (2006) Adaptation to climate change: key terms. OECD, Paris
- Lloyd SJ, Kovats RS, Chalabi Z (2011) Climate change, crop yields, and under nutrition: development of a model to quantify the impact of climate scenarios on child under nutrition. *Environ Health Perspect* 119(12):1817–1823
- Lobell DB, Schlenker W, Costa-Roberts J (2011) Climate trends and global crop production since 1980. *Science* 333(6042):616–620. <https://doi.org/10.1126/science.1204531>
- Macharia J, Ngetich F, Shisanya C (2020) Comparison of satellite remote sensing derived precipitation estimates and observed data in Kenya. *Agric For Meteorol* 284:107875. <https://doi.org/10.1016/j.agrformet.2019.107875>
- Mpandeli S, Nhamo L, Moeletsi M, Masupha T, Magidi J, Tshikolomo K, . . . Mabhaudhi T (2019) Assessing climate change and adaptive capacity at local scale using observed and remotely sensed data. *Weather Clim Extrem* 26:100240. <https://doi.org/10.1016/j.wace.2019.100240>
- Myhre G, Shindell D, Bréon F-M, Collins W, Fuglestedt J, Huang J, Koch D, Lamarque J-F, Lee D, Mendoza B, Nakajima T, Robock A, Stephens G, Takemura T, Zhang H (2013) Anthropogenic and natural radiative forcing. In: Stocker TF, Qin D, Plattner G-K, Tignor M (eds) Climate change 2013: the physical science basis. Contribution of working group I to the fifth assessment report of Intergovernmental Panel on Climate Change, pp 659–740. <https://doi.org/10.1017/CBO9781107415324.018>
- Nnadi OI, Liwenga ET, Lyimo JG, Madukwe MC (2019) Impacts of variability and change in rainfall on gender of farmers in Anambra, Southeast Nigeria. *Heliyon* 5(7):e02085. <https://doi.org/10.1016/j.heliyon.2019.e02085>
- Ogolla J, Abira M, Awour V (eds) (1997) Potentials impacts of climate change in Kenya. Motif Creative Arts Ltd, Nairobi
- Patz JA, Olson SH, Uejo CK, Gibbs HK (2008) Disease emergence from global climate and land use change. *Med Clin N Am* 92:1473–1491
- Schaeffer M, Baarsch F, Adams S, de Bruin K, De Marez L, Freitas S, . . . Hare B (2013) Africa’s adaptation gap: technical report. Climate change impacts, adaptation challenges and costs for Africa. United Nations Environment Programme, New York. <http://www.unep.org/pdf/AfricaAdaptationGapreport.pdf>. Accessed 10 Aug 2016
- Schellnhuber HJ, Hare W, Serdeczny O, Adams S, Coumou D, Frieler K, . . . Rocha M (2012) Turn down the heat: why a 4°C warmer world must be avoided (no. INIS-FR–14-0299). *Sauvons le Climat* (SLC), Paris

- Schlenker W, Roberts MJ (2009) Nonlinear temperature effects indicate severe damages to U.S. crop yields under climate change. *Proc Natl Acad Sci U S A* 106(37):15594–15598. Retrieved from: <http://www.pnas.org/content/106/37/15594>
- UNEP (2002a) *Global Environment Outlook 3*. Earthscan Publication, London
- UNEP (2002b) *Vital climate graphics Africa*. UNEP Publication, Nairobi
- Wheeler T, Craufurd P, Ellis R, Porter J, Vara Prasad P (2000) Temperature variability and the yield of annual crops. *Agric Ecosyst Environ* 82:159–167
- Williams JW, Jackson ST, Kutzbach JE (2007) Projected distributions of novel and disappearing climates by 2100 AD. *Proc Natl Acad Sci* 104(14):5738–5742

**Open Access** This chapter is licensed under the terms of the Creative Commons Attribution 4.0 International License (<http://creativecommons.org/licenses/by/4.0/>), which permits use, sharing, adaptation, distribution and reproduction in any medium or format, as long as you give appropriate credit to the original author(s) and the source, provide a link to the Creative Commons license and indicate if changes were made.

The images or other third party material in this chapter are included in the chapter's Creative Commons license, unless indicated otherwise in a credit line to the material. If material is not included in the chapter's Creative Commons license and your intended use is not permitted by statutory regulation or exceeds the permitted use, you will need to obtain permission directly from the copyright holder.







# Agricultural Interventions to Enhance Climate Change Adaptation of Underutilized Root and Tuber Crops

# 4

Joseph P. Gweyi-Onyango, Michael Ajanja Sakha, and Joyce Jefwa

## Contents

Introduction .....	62
Major Roots and Tuber Crops .....	65
Cassava .....	65
Sweet Potatoes .....	65
Yam .....	66
Irish Potato .....	66
Cocoyams (Arrow Roots) .....	67
Root and Tuber Crop Production in Kenya .....	67
Agricultural Interventions for Adaptation to Climate Change .....	69
Bio Fertilizers .....	69
Organic Agriculture .....	72
Tie-Ridging .....	74
Improved Seed Varieties .....	75
Management of Community Seed Banks .....	75
Cropping Systems .....	76
Irrigation Method .....	77
Exploiting Abandoned Lands .....	78
Agroforestry Practice .....	79
Clean Seed Production Technologies .....	79
Nutrient Use Efficiency (NUE) .....	80
Conclusion .....	81
References .....	81

This chapter was previously published non-open access with exclusive rights reserved by the Publisher. It has been changed retrospectively to open access under a CC BY 4.0 license and the copyright holder is “The Author(s)”. For further details, please see the license information at the end of the chapter.

J. P. Gweyi-Onyango

Department of Agricultural Science and Technology, Kenyatta University, Nairobi, Kenya

M. A. Sakha (✉) · J. Jefwa

Botany Department, National Museums of Kenya, Nairobi, Kenya

© The Author(s) 2021

W. Leal Filho et al. (eds.), *African Handbook of Climate Change Adaptation*,  
[https://doi.org/10.1007/978-3-030-45106-6\\_40](https://doi.org/10.1007/978-3-030-45106-6_40)

61

---

**Abstract**

Agricultural intensification worldwide is increasingly relying on a narrow range of crops such as rice, wheat, and maize. The reliability on this relatively small numbers of food diversities raises a very serious concern about the sustainability managing our nutrition today and in the future. We conducted a scoping review using online databases to identify various agricultural interventions that can be utilized for enhancement of underutilized root and tuber crops adaptability under the current observable effects of climate change. This is because reports of underutilized crops' adaptability to climate change continues to remain anecdotal with limited research capacity to support them. The results mooted a wide range of crop production techniques that can be utilized in production of root and tuber crops. They includes biofertilizers, tied ridging method, improved seed varieties, management of community seed banks, cropping systems, irrigation methods, exploiting abandoned lands, agroforestry practice, clean seed production technologies, and nutrient use efficiency. Based on the findings, each of these interventions plays different roles in management of the negative impacts brought up by climate change and thus they would be useful when adopted in combination since package adoption would enable farmers to benefit from the positive synergy of the selected interventions. The interventions are therefore recommended not only for sustainability but also for profitable production to meet feed, food, energy, and fiber needs and foster economic growth in the ever changing world. Therefore this chapter contributes immensely towards the development of innovative mechanisms for strengthening the resilience of root and tuber crop.

---

**Keywords**

Agricultural intensification · Sustainability · Adaptability

---

**Introduction**

The root and tuber crops are group of plants which yields tubers, starchy roots, corms, stems, and rhizomes. Okigbo (1989) defined while tuber crops as crops with edible carbohydrate-rich storage organs developing wholly or partly from underground stems while root crops as edible crops with energy-rich underground plant structures developing from modified roots. Major tropical root and tuber crops are: cassava (*Manihot esculenta*); potato (*Solanum spp.*); sweet potato (*Ipomea batata*); yam (*Dioscorea spp.*); aroids like elephant foot yam [*Amorphophallus paeoniifolius* (Dennst.) Nicolson]; taro [*Colocasia esculenta* (L.) Schott.], and tannia [*Xanthosoma sagittifolium* (L.) Schott.]. Additionally, there are minor tubers such as Chinese potato [*Plectranthus rotundifolius* (Poir.) J.K. Morton.]; yam bean [*Pachyrhizus erosus* (L.) Urban], and arrowroot [*Maranta arundinacea* (L.)]. These crops are vegetatively propagated and plays major roles in food sector

especially by managing the well-being of people in developing countries. According to FAO (2009), these crops are produced in approximately 53.93 million hectares globally and this produce about 736.747million tonnes annually.

In Sub-Saharan Africa (SSA), many people highly depend on root and tuber crops but not all as a contributory if not the primary source of their food and nutrition. This is also because of the role they play in food security, their ability to resist drought, as well as their capacity for commercial processing in Kenya. Actually they were ranked as the second most important food crop in 2019 by the ministry of agriculture after cereals (MoALF 2019). At the moment, the Kenya is producing 3.68 M MT of Irish potatoes, cassava, sweet potatoes, yam, and cocoyams. However, their yield is below average which is much way below country's potential. For instance Irish potatoes stands at 7MT per ha compared to the potential of 25 MT achieved under optimal husbandry practices (MoALF 2019).

Root and tuber crops are considered to be resilient because they are more adaptable to marginal areas. This areas are characterized by edaphic and climatic conditions that may not be favorable to the non-native materials. These crops are tolerant to poor soils and drought stress. They also grow very well on well-drained soils, with good organic matter, and especially those with loose and friable fertile clay loam or loam. Moreover, the optimal conditions for their growth are: annual rainfall ranging between 1000 and 2000 mm, temperature of 18–35 °C, and a soil pH ranging between 5 and 7.5. Nevertheless their planting differs from another case in point Coleus potato, tuberous rhizomes, or seed tubers are normally planted about 5 cm in depth on raised beds and are spaced at 15–20 cm while in Amora; they are planted at about 15 cm deep and a distance of 30–40 cm (Codd 1985).

These crops are also well known to serve as important components of subsistence farming system in their native areas and have played crucial, if not weighty roles income generation and in household food security of the rural areas. As food crops these crops are very rich in carbohydrates and on that account they play a paramount role as part of our daily diet, accounting for over 50% of the total staple food. In terms of energy requirements for global population, they contribute 3.9% energy that is sweet potato 1.5%, cassava 1.9%, yams and other root and tuber crops 0.3%. Along with this potatoes produce additional protein and dry matter per hectare than key cereals (Birch et al. 2012). Monneveux et al. (2013) also reported that potatoes have higher water generative capacity than cereals and are considered among the most energy productive crops, producing 5,600 kcal/m<sup>3</sup> of water, compared to 3860 in maize, 2300 in wheat, and 2000 in rice. Other root and tuber crops such as taro, yautia, and yam, also have notable energy values and inconsistent nutritional properties, including vitamin C, dietary fiber, and carotenoids (Asiedu and Sartie 2010). At the same time these crop plays a meaningful role as cash crops. They literally hold strong economic potential and can be financially rewarding to the agricultural economies. Finally these crops are progressively being used as a source of raw material for industrial use and for feeding the livestock. In comparison to other staple food crops, they provide comparatively

huge amounts of nutrition and energy per unit area and time, they require less-intensive management systems even under risky environmental conditions. Consequently, these crops are very important in fighting famine caused by floods, droughts, civil strife, and other climatic catastrophe such as pests and diseases which seems to be unending in some countries.

Climate change is a menace posing extreme stress to the environment and also to the humans. Deschenes and Greenstone (2006) reported that it has an adverse effect on humans and their income-generating activities especially agriculture owing to its dependence on nature, largely temperature and precipitation. In addition climate change influences soil functions both directly and indirectly. The direct influence include soil process, namely, changes in organic matter and nutrient cycling and this is through adjusting temperature and moisture regimes or through increased soil erosion rates caused by increased frequency of intense rainfall occurrence. This causes severely effects on agriculture especially on the crops being grown. As a matter of fact, Africa is one of the riskiest continents to the ongoing climate variability causing robust negative economic impacts. This vulnerability is accentuated by development challenges specifically ecosystem degradation and endemic poverty which are supported by limited access to capital, infrastructure, markets, and technology (IPCC 2007).

Small-scale farmers in sub-Saharan Africa, who are the majority, have historically been confronted with high climate variability. Some of its negative effects on farm include decreased soil fertility and limited plant growth (Dhankher and Foyer 2018). Despite smallholder farming systems having proven to be resilient and being viable in risk-prone environments, climate change is likely to outpace their current coping capabilities (Morton 2007), if effective measures are not implemented. Specifically, low levels of income and technology, coupled with isolation from markets and lack of institutional support, are common characteristics of smallholder farming systems that make them particularly vulnerable to changes in external conditions (Morton 2007). This is worsened by the fact that food security and livelihood programs mostly stress on grain crops such as maize, rice, and wheat. In support of this, Atakos (2018) reported that only one or two studies have looked into the future potential of root tuber crops and their possible importance even with climate change. Our dependence on this relatively small number of food species therefore elevates serious concerns of feeding the whole world sustainably. In such context, investment in sustainable agricultural technologies and practices becomes crucial for adaption to sustain crop productivity to be able to feed the growing populations. In particular to able to reduce the negative effects of climate change on the agri-food system, Sombroek and Gommers (1997) proposed that populations and economic systems must be able adapt to future climatic conditions.

Since root and tuber crops play a great role as source of nutrition, and on the other hand, researchers are advocating for mitigation and adaptation as possible options to combat the adverse effects of climate change on agriculture, this chapter therefore focus on agricultural interventions that can enhance climate change adaptation of underutilized root and tuber crops.

## Major Roots and Tuber Crops

### Cassava

Cassava (*Manihot esculenta*) is a perennial woody shrub which grows as an annual crop. It is also referred as manioc, mandioca, or yuca, which is in the spurge family (Euphorbiaceae) (Hillocks et al. 2002). This crop is also known as the “king of tropical tuber crops” and has a significant position in the global agricultural economies. According Bennett (2015), the crop is ranked as the second most important food source in Africa with regard to calories consumed per capita. Cassava is native to South America (Allem 2002) but it is grown all over tropics and subtropics. It is largely produced in Brazil followed by Thailand, Nigeria, DR Congo, and Indonesia, even though about half of the global production is in Africa. The crop is grown in about forty African countries where it is recognized as an important food crop particularly in Nigeria, DR Congo, Ghana, Mozambique, Uganda, Cameroon, Madagascar, Angola, Côte d’Ivoire, Tanzania, Benin, and Kenya. FAO 2000 revealed that about 70% of Africa’s cassava production is obtained in Nigeria, Tanzania, and DR. Congo.

It has been proposed that cassava could potentially be hardy to climate change than other staple crops (Jarvis et al. 2012). Likewise Nweke et al. (2002) revealed that cassava can grow well in marginal lands, and that it requires low farm inputs. The average cassava root yield is about 11.6 t/h worldwide (FAO 2018) which is exceedingly lower than its potential yield of 60 t/ha under better farming practices which was reported in some parts of Africa (Kintché et al. 2017). Even though FAOSTAT (2014) reported that world production of cassava storage roots improved tremendously from 176 to 277 million Mg between 2000 and 2013. Major limiting factors for cassava production are low soil fertility and pests and diseases.

### Sweet Potatoes

Sweet potato (*Ipomoea batatas* (L.) Lam) is a herbaceous dicotyledonous plant belonging to Convolvulaceae family (Purseglove 1972). The plant has creeping, perennial vines and adventitious roots (Purseglove 1972). It is grown for its green leaves and storage roots which are very useful for human consumption, feeding animal, and to a certain extent, for industrial purpose (Woolfe 1992). For that reasons, according to Motsa et al. (2015), the crop plays a critical role for food security and income generation for many households. Consequently, the crop is extensively cultivated in tropical, subtropical, and frost-free temperate climatic areas of the world (Onwueme and Sinha 1991).

Sweet potato is ranked as the seventh most important food crop globally because it contributes majorly in terms of energy and nutrition (Marques 2015). The crop also matures at a very short time on marginal lands and play an important role in the economy of poor households (Nath et al. 2007). As stated by Ukom et al. (2009), the crop is important for its storage roots which can either be baked, cooked, fried, or

roasted for human consumption. Its storage roots can also be processed into flour for baking bread, making noodles, as well as for alcohol production. In addition, the storage roots are very good source of vitamin A, vitamin C, vitamin B6, dietary fiber, manganese, copper, potassium, and iron (Baybutt et al. 2000). Even though the crop has a high storage root yield potential ranging between 20 and 50 t/ha (Kivuva et al. 2014), in Sub-Saharan Africa, this is yet to be realized since its production is still less than 10 t/ha (FAOSTAT 2017).

## Yam

Yams (*Dioscorea spp.*) are tropical plants with large food reserve in their underground tubers and comprise of various species that originated from Southeast Asia, West Africa, East Africa, Brazil, and Guyana. The main species are *Dioscorea alata* (greater or water yam), *Dioscorea cayenensis* (yellow guinea yam), *Dioscorea esculenta* (lesser yam), and *Dioscorea rotundata* (white guinea yam) (Arnau et al. 2010), and this comprises both annual and perennial species. They cultivated all over the tropics and in some parts of subtropics and temperate areas. FAO (2000) reported that up to 95% of the world's production is realized in West Africa.

The tubers are very important and constitute stored wealth since they can be sold all-year-round by farmers because they can be stored for relatively longer period of time in comparison with other tropical fresh produce (Aidoo 2009). The tubers also provide a substantial amount of vitamins (vitamin B1 and C), potassium, and iron (Rudrappa 2013). Most essentially many of the yam species have high content of steroidal saponins which make them suitable for industrial use as corticosteroids precursors and anti-cancer bioactive compounds. Besides being staple food that is consumed by about 155 million people in the world, yams are grown as cash crop, as medicinal plant, and have high cultural value for the groups cultivating it (Coursey 1981).

Major hindrance for intensifying yam productivity is low soil fertility (both in terms of macro- and micronutrient deficiency) (O'Sullivan and Ernest 2007). This is because *Dioscorea spp.* are high-nutrient-demanding crops (Carsky et al. 2010). Therefore, yams still remains being categorized as orphan crop (Naylor et al. 2004).

## Irish Potato

Irish potato (*Solanum tuberosum* L.) is indigenous to South America near the present border of Peru and Bolivia but not Ireland (Spooner et al. 2005). According to Robert and Cartwright (2006), it belongs to the family solanaceae, and is named after Ireland country because it is associated with the Irish potato famine, also known as the Great Hunger. This was a historic famine caused by *Phytophthora infestans* which infected Irish potato crop. This crop plays a crucial role in the economy and is ranked number one non-grain food commodity (Rykaczewska 2013). Globally it is ranked third most important food crop in consumption after rice and

wheat (Birch et al. 2012). It has a worldwide cultivation exceeding 19.34 million hectare in more than 158 countries, with an approximate yearly production of 364 million tons (FAOSTAT 2014). According to Tshisola (2014) in Africa, it is regarded as one of the most important food crops.

Practically the crop contains all the requisite dietary components such as protein, vitamins, carbohydrates, essential nutrients, and minerals (Sriom et al. 2017). Additionally it is a source income and employment opportunity in developing countries. Unfortunately, limiting factors to its production include short day lengths, low light intensities, high temperatures, and most importantly low soil fertility (Jones and Wendt 1994).

### **Cocoyams (Arrow Roots)**

Cocoyam (*Colocasia esculenta* (L.) Schott.) is a member of Araceae family (Purseglove 1975) and is a subsistence and emergency food source globally (IFA 1992). It is an important starchy tuberous herbaceous perennial plant (Purseglove 1975). The crop has different varieties and commonly produced varieties are *Colocasia esculenta* (Taro) and *Xanthosoma sagittifolium* (Tannia). They also occur in all tropics and have been domesticated in most communities in Oceania, Africa, and Asia (Ramanatha et al. 2010).

The crop is cultivated for its edible cormels, corms, and leaves as well as other traditional uses (Pinto and Onwueme 2000). As food for consumption, it is essentially a source of calories obtained from underground corm and cormel (Davies et al. 2008). Their leaves which resemble spinach are nutritious and are source mineral and vitamin (Sefa-Dedeh and Kofi-Agyir 2002). Primarily, fresh cocoyam hold about 70–80% water, 20–75% carbohydrate, and 1.5–3.0% protein (Udo et al. 2005). It actually contains over 80% and 240% higher digestible crude protein than yam and cassava, respectively. Therefore this crop is high-ranking nutritionally than cassava and yam in terms of protein and other elements such as vitamin and mineral content. However, the crop still remains to be underexploited food resource (Onyeka 2014).

---

### **Root and Tuber Crop Production in Kenya**

Ministry of agriculture, livestock, and fisheries of Kenya report indicate that roots and tuber crops production stagnated for a period of 3 years (2012 to 2015) with an average cultivated zone of about 240,000 ha, which gave a total production level of 3.3 million MT although these reduced to 2.4 MT in 2016 (MoALF 2019). This elicited the national government to draft a strategy (the national root and tuber crops development strategy 2019–2022) to help in upscaling their production. This was an initiative of the national government of Kenya, but it was being supported by other key stakeholders such as the European Union, and by organizations like Self Help Africa (Table 1).

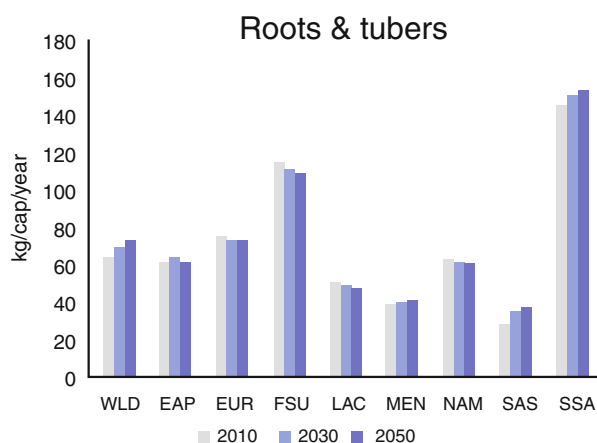
**Table 1** Production trends of roots and tuber crops in Kenya (2012–2016)

Commodity	Area (Ha)					Production (MT)				
	2012	2013	2014	2015	2016	2012	2013	2014	2015	2016
Year										
Irish potato	99,475	104,560	115,604	1,436,718	1,667,690	1,626,027	1,172,262	1,150,112		
Sweet potato	66,971	58,509	61,067	859,549	729,645	763,643	1,232,332	697,324		
Cassava	73,144	65,634	63,7265	930,922	935,089	858,461	709,926	571,845		
Cocoyams	2,869	3,654	2,155	26,716	45,346	27,619	–	–		
Yams	874	998	1210	10,143	13,569	20,028	–	–		
Total	245,345	235,368	245,775	3,266,060	3,393,352	3,297,792	3,114,520	2,419,281		

Source: MoALF 2019



**Fig. 1** Forecast sustained per capita demand for roots and tubers to 2050. (Source: Wiebe 2015). WLD = World; EAP = East Asia and Pacific; EUR = Europe; FSU = Former Soviet Union; LAC = Latin America and Caribbean; MEN = Middle East and North Africa; NAM = North America; SAS = South Asia; SSA = sub-Saharan Africa



In sub-Saharan African counties, there are noticeable cultural preferences for root and tuber crops, and using the Impact General Equilibrium Model, a 2015 analysis the International Food Policy Research Institute revealed that per capita consumption of these crops continues to rise (Fig. 1). Therefore, because of its low productivity brought by the effects of climate change and which cannot meet their demand, there is need to enhance their resilience to climate change using innovative ways.

## Agricultural Interventions for Adaptation to Climate Change

Farmers, especially small-scale farmers, still use indigenous farming practices which lead up to ultimately low yields. This is coupled to farmer's nonadoption of better crop production strategies and lack of improved and high-yielding varieties. Moreover, these farmers on their own do have other alternatives that can help them bear and share losses or modifies threats. On the other hand, climate change adaptation should be built on sound and a working ecosystems, as it provides a variety of benefits and services on which agricultural production systems and rural livelihoods depend. Therefore, this calls for adoption of new technologies while producing these crop to help us throughout this challenging times. To this end, this chapter provide the suitable technologies available that can be exploited to increase root tuber crops adaptability to climate change. The technologies include:

### Bio Fertilizers

By definition, bio fertilizers are products containing natural occurring micro-organisms that are artificially multiplied for ameliorating soil fertility. Each and every type of crops grown in different agro-ecological zones can benefit from their

use, since they are valuable to the environment. This is because they are enabling farmers to minimize the use of modern chemical fertilizers in crop production. In particular, they are designed to improve nutrient availability or reduce pest pressure. According to Malik et al. (2011), constant use of microbial-based bio-fertilizers enables microbial population to persist in the soil which helps in soil fertility conservation (Table 2).

**Phosphate-Solubilizing Microorganisms (PSM):** They are a group of beneficial microorganisms that capable of hydrolyzing inorganic and organic insoluble phosphorus compounds to soluble phosphorus form that can easily be absorbed by plants. They include various soil fungi and bacteria, and important species are *Pseudomonas*, *Bacillus*, *Penicillium*, and *Aspergillus*. Hikmatullah and K. Nugroho (1994) reported that their abilities of phosphate solubilization from organic materials differs due to their differences in their capacity to produce organic acids that play a key role in releasing phosphorus bound by aluminum, iron, and calcium ions. Specifically, this is because organic acids released by microorganisms are different in quantity and quality (Jha et al. 2013). Some of the organic acids released that are capable of freeing AI-P bond include Malic acid, malonic, tartaric, oxalic, and citric (Marbun et al. 2015). These organic acids decrease the soil pH in their locality to cause the dissolution of bound phosphates in soil. Khan et al. (2009) reported that 1 g of fertile soil can hold  $10^1$  to  $10^{10}$  bacteria, and their live weight may exceed  $2,000 \text{ kg ha}^{-1}$ . Similarly Chen et al. (2006) outlined that among the whole microbial community in soil, phosphate solubilizing bacteria comprise 1–50% while phosphate solubilizing fungi comprise 0.1–0.5% of the total respective community. Therefore, microbial-based biofertilizers can be utilized to boost soil microbial population whenever they are low and when cultivating root and tuber crops. With high density of PSMs, it is expected that microbial phosphate solubilization can compete effectively with other microorganisms in the soil.

**Phosphorus Mobilizing Fungi:** This group comprise of the arbuscular mycorrhiza fungi (AM fungi) that belongs to the phylum Glomeromycota (Schüßler et al. 2001). The fungi form a mutualistic relationship with most terrestrial plants. In the association, the plants benefit through various ways such as water and essential

**Table 2** Types of biofertilizers for root and tuber crops

<b>Phosphorus-solubilizing microorganisms</b>		
1)	Bacteria	<i>Bacillus megaterium</i> var. <i>phosphaticum</i> , <i>Bacillus subtilis</i> , <i>Bacillus circulans</i> , <i>Pseudomonas striata</i>
2)	Fungi	<i>Penicillium</i> sp., <i>Aspergillus awamori</i>
<b>Phosphorus mobilizing fungi</b>		
1)	Arbuscular mycorrhiza fungi	<i>Glomus</i> sp., <i>Gigaspora</i> sp., <i>Acaulospora</i> sp., <i>Scutellospora</i> sp. & <i>Sclerocystis</i> sp.
<b>Micro nutrients solubilizers</b>		
1)	Silicate solubilizers	<i>Bacillus</i> sp.
<b>Plant growth promoting rhizobacteria</b>		
1)	<i>Pseudomonas</i>	<i>Pseudomonas fluorescens</i>

Source: (Kumar et al. 2017)

nutrients uptake, and also by enhancing plant tolerance to biotic and abiotic stresses (Augé et al. 2015). This multifunctional ability and diversity of AM fungi has led to the development of mycorrhizal inoculants for use as biofertilizers in agriculture. Actually, most land plants are facultative symbionts such that they gain from AM fungi, yet they can also live without them, although at reasonable fitness cost. However, some plant species are obligate parasites on the fungus such that they are fully dependent on fungal nutrition (mycoheterotrophs) and have lost photosynthetic capacity (Graham et al. 2017).

Since mycorrhizal inoculations has been used for decades to stimulate plant growth for several crop, root and tuber crops which are highly mycorrhizal could also profit from the numerous services offered by this fungi not only in increasing their resilience to climate change but also their productivity. For instance, according to a report by Sieverding (1991) AM fungi inoculation of cassava increased its fresh roots weight by up to 5 t/ha.

**Micronutrients Solubilizers:** Such as Silicate solubilizing bacteria (SSB) are microorganisms that are able to degrade silicates and aluminum silicates in soil. These microorganisms such as *Collimonas*, *Janthinobacterium*, *Proteobacteria*, *Aminobacter*, *Burkholderia*, *Dyella*, and *Frateuria* are reported to solubilize the biotite which hold substantial amounts of silicate minerals (Uroz et al. 2009). During their metabolism, various organic acids are released which plays double roles in silicate weathering. These species supply hydrogen ions to the media which encourages hydrolysis. As well the organic acids let out such as oxalic acid, Keto acids, citric and hydroxyl carboic acids form complexes with cations, which foster their removal and retention in the media in a dissolved state.

Since phosphorus and potassium are crucial macro elements for plant growth and development, P and K chemical fertilizers are regularly applied to replace the removed minerals in soil for yield optimization; SSB also plays an efficient role not only in solubilizing insoluble forms of silicates but also potassium and phosphates, hence this microorganisms when applied would increase the soil fertility, thereby enhancing root and tuber crops productivity.

**Plant Growth Promoting Rhizobacteria (PGPR):** Also referred as yield improving bacteria (YIB) are a group of bacteria that are known to increases plant growth and yield by-way-of several plant growth promoting substances as well as bio fertilizers. They are distinguished as free-living soil microorganisms colonizing plant roots and brings into play a beneficial effect on plant development and/or subdue plant pathogens. The microorganisms include; *Alcaligenes*, *Agrobacterium*, *Bacillus*, *Bradyrhizobium*, *Burkholderia*, *Enterobacter*, *Frankia*, *Klebsiella*, *Pseudomonas*, *Arthrobacter*, *Azospirillum*, *Azotobacter*, *Rhizobium*, and *Serratia*. The genera enclose most PGPR with well-known benefits on different crop species (Tailor and Joshi 2014).

There are numerous mechanisms through which the bacteria helps the plants including: inducement of increased nutrient uptake (termed Bio fertilizers), provision of nutrients by way of nitrogen fixation and phosphate solubilization, better plant growth promotion through the production of phytohormones (termed Bio stimulants), and the suppression of plant pathogens or the induction of systemic

resistance to diseases (termed Bio protectants) (Vessey 2003). Also species of *Pseudomonas* and *Bacillus* produce plant growth regulators that stimulate crops to produce many fine roots which increases the surface area over which plant roots absorb water and nutrients.

Due to their multiple roles, research on these growth regulators has been rising and a number of experiments (both *in vivo* and *in vitro*) have been tested on different crops including root and tuber crops. For example, *Bacillus* and *Pseudomonas* sp. have been tried on potatoes and they have helped in improving phosphorus uptake, promoting indole acetic acid (IAA) production, and for biocontrol (Hunziker et al. 2015). Therefore, these microorganism can be very useful in fostering the growth and yield of root and tuber crops, with minor inputs of agrochemicals.

## Organic Agriculture

Organic agriculture can be defined as a production system that sustains the health of soils, ecosystems, and people. This management system helps in mitigating climate change by diminishing the emissions of greenhouse gases and by sequestering carbon dioxide from the atmosphere. Organic agriculture is reported to be the most sustainable approach in food production. This is because it highly emphasizes on recycling practices and use of low external input for realization of high output. In addition, its principles dwell on increasing soil fertility, its diversity at all levels, and mitigating soil erosion.

Some management options of organic agriculture are generally considered to have both mitigation and adaptation benefits since they increase soil carbon. Ciaia et al. (2013) stated that soil carbon provides a mitigation benefit by storing carbon taken out of the atmosphere by plants during photosynthesis. Soils with higher amounts of carbon are associated with greater water holding capacity, increased nutrient availability, and higher yield potentials, which could prove adaptive in a future climate (Stokes and Howden 2010). Organic agriculture practices are innovative way that can be used to increase these crops adaptability to climate change.

## Soil Organic Matter Management

Soil organic matter (SOM) is a major measure of agricultural productivity and general soil health. Mean annual temperature and precipitation are major climatic drivers of SOM levels and dynamics. Long-term field trials and farm comparison show that organically managed soils have notably higher organic matter content. According to Foereid and Høgh-Jensen (2004), it was evaluated that under Northern European conditions, changing from conventional to organic agriculture resulted in enhanced SOM ranging from 100 to 400 kg ha<sup>-1</sup> yearly during the first 50 years. Therefore, after a hundred years of organic agriculture, it is estimated that a steady state of stable level of SOM would be realized.

Environmental Protection Agency estimated that composting 1 ton of organic matter gave a net storage of about 600 pounds of carbon dioxide (EPA 2006). Even though all kinds of agriculture poses the capability of sequestering carbon, essentially organic agriculture can sequester remarkably more carbon than conventional

systems (Don 2007). This is because organic agriculture restrains the use of chemical fertilizer and pesticide and integrates use of cover crops especially from leguminous plants, and place in order increasing soil organic matter as the first step. Therefore, to sequester more carbon as possibly brought up by climate change, it is necessary to incorporate SOM management practices when producing root and tuber crops.

### **Mulching**

Mulching is a traditional practice which involves the covering of soil surface with organic material which plays a vital role in soil and plant protection. Mulches are capable of changing the environment around the plants and control weed and annual grasses, soil erosion and runoff, and soil-borne diseases. Besides, they decrease moisture evaporation, increase water absorption and retention, and boost root growth. Organic or natural mulches such as compost provide many favorable and fertilizer-like effects for root and tuber crops production by supplying abundant plant nutrients, during their decaying process.

Owing to climate change that has resulted in land slide, high temperature and flashfloods, mulching is necessary since several types of mulching practices have exhibited reduction in soil erosion by more than 90% compared to bare soil (Mostaghimi et al. 1994). Unger (1994) argued that mulches with low carbon to nitrogen ratio decompose rapidly providing nutrients for crop growth at a faster rate. Furthermore, studies in Latin America and Papua New Guinea revealed the benefits of mulching cassava and sweet potato plants for yield stabilization (Ossom et al. 2001). To support this, Coling (1997) reported that mulches of plastic film enhanced **dry matter** accumulation, plant height, leaf area index, and tuber yield of potatoes. Similarly Sarma et al. (1999) after planting potato cv. Kufri megha on ridges and flat seedbeds in combination with mulches and earthing up, he confirmed that mulching with black plastic film resulted in enhanced tuber yield which was greater than the normal cultivating method. This is because plastic mulch literally conserved the soil moisture which helped in better crop growth and tuber yield. Similarly, mulching the soil has been positively correlated with plant species richness.

As a normal practice, root and tuber crops are usually cultivated on ridges where soil erosion and weeds can be a menace. Therefore, for their effective production mulching is important since it is a valuable practice that can be used to control weeds. This is because mulching prevents weed growth and development by blocking light from reaching the soil surface where their seeds lie. In root and tuber crops, mulching could assume an important function of lowering soil temperatures in addition to soil moisture conservation (Sangakkara et al. 2004).

### **Zero Tillage**

Zero tillage which is also referred as direct drill or no till is an agricultural practice of cultivating crops or pasture without disturbing the soil surface through tillage. Its aim is to conserve soil and moisture through nondisturbance of the soil surface and also by ensuring that 30% or more of crop residues are conserved on the surface (Erenstein and Laxmi 2008). According to Fernández et al. (2010), the practice has been documented widely for its benefits including protecting the soil against erosion

**Table 3** Area under zero tillage by continent

Continent	Area (ha)	Percentage of total (%)
South America	49,579,000	46.8
North America	40,074,000	37.8
Australia and New Zealand	17,162,000	11.5
Asia	2,530,000	2.3
Europe	1,150,000	1.1
Africa	368,000	0.3
World total	115,863,000	100

Source: Derpsch et al. (2010)

and managing soil structure. Also, this practice increases carbon sequestration and activities of the microorganisms (Helgason et al. 2010) (Table 3).

Studies show that practices that reduce soil disturbance and intensify cropping have the potential of increasing soil organic matter (SOM) and improving soil health. For instance, soil disturbance with tillage generally promotes loss of SOM by facilitating microbial degradation of SOM, promoting crop-residue-soil contact, and placing residues into more favorable subsurface moisture regimes as compared to surface placement under no-tillage (Halvorson et al. 2002). By adopting no till practices in root and tuber crops production, soil conservation would be improved greatly, water and wind erosion would be considerably reduced, while the crops would yield more since they would protect from pests and external environment.

## Tie-Ridging

Tie-ridges are soil and moisture conservation structures that involves the construction of small basins that are rectangular shaped. This basins are formed within the furrow of cultivated fields mainly to enhance the storage of rain water and for allowing more time for water to percolate in the soil (Wiyo et al. 1999). Belachew and Abera (2010) reported that the stored water can accessed by plants for a longer period of time better than it can be used when there is run off. Ridging across slope is highly recommended in dry areas for soil and water conservation in crop production (Kumwenda 1999).

Mechanized ridging is achieved either by animal-drawn ridgers, as it is commonly practiced in African for cassava and other food crops production, or by tractor-mounted ridgers which is a major practice for cassava production in Asian countries (Suyamto and Howeler 2001). The purpose of mechanization is to reduce hard work and in the process increase the scale of production crops. Although when using tie-ridging the optimum height of the ridge depends on the soil type and the cultivar being grown.

Benefits of tie-riding reported include: increased number of roots per plant which is identified as a major contributory factor to the higher yields on ridges (Suyamto and Howeler 2001). In particular, ridging has been shown to increase sweet potato yields by 38% (Ennin et al. 2003) over mounding, mainly as a result of increased

plant population density and better weed suppression on ridges. Shetto (1999) reported that many farmers find weeding of cassava to be easier on ridges than on mounds; it is also effective in soil erosion management and results in high yields. Ennin et al. (2009) recommended the cultivation of cassava, yams, and other tuber crops on tie-ridges for realization of economizing the available planting space and thus increase on the planting density. Ridging is also responsive to improved farming practices such as herbicide application, fertilization, and yam staking, and this is due to the regular spacing of crops obtained under the systems.

The concept behind creation of tie-ridges is to optimize water infiltration, improvement of soil-water management, enhancement of root growth and nutrient uptake, and enhancement of rooting depth which is also supported by FAO (2000). Therefore, tie-ridge would play a significant role in production of root and tuber crops.

### Improved Seed Varieties

Unlike the other true seed crops, root and tuber crops are propagated vegetatively. The benefits of improved seed varieties for root and tuber crops can only be realized through breeding and addressing the challenges in their seed value chain. This can be achieved through having a functioning seed systems and directly linking of the systems as a key tool of addressing the issue of improved seeds. This can further be linked in addressing the issues of climate change.

To this effect, the International potato center (CIP) has fostered and expedited their breeding schemes that shortens the time it takes in developing and releasing new varieties of root and tuber crops actually from 8 to 4 years. To this effect, their breeders have released potato varieties that are tolerant to heat, salinity, and drought. Some of the varieties are Tacna and Unica which were developed and tested in Peru; Raniag variety in Philippines; and Kinga, Kiningi, and Meva developed in Africa (Atakos et al. 2018). Further variety Tacna was released in the Republic of China under the name Jizhangshu 8, and had covered 20,000 ha by 2008. Recently work has been going on to develop climate change resilient potatoes that have the characteristics of drought and salinity tolerance, and according to Atakos et al. (2018), variety Sarnav has been released in Central Asia (Uzbekistan and Tajikistan), while heat and salinity tolerant BARI Alu-72 has been released in Bangladesh. With minimal precipitation being realized ranging between 15% and 20% and new experiences in temperature increase of 2–3 °C due to the effects of climate change, these clones have shown a high degree of tolerance to these effects (CIP 2017). On that account, such efficient breeding practices that delivers improved seed varieties of root and tuber crops should be supported especially in the area of improving their resilient to climate change.

### Management of Community Seed Banks

Community seed banks are entities that are governed locally and they are managed in an informal manner by institutions whose core function is to maintain seeds for

local use (Development Fund 2011). Vernooy et al. (2014) reported that the community seed banks were founded by Rural Advancement Foundation International (RAFI) now known as ETC Group or Action Group on Erosion, Technology, and Concentration. The three key functions of the community seed banks are: (i) to conserve the plant genetic resources; (ii) to make the availability and accessibility of diverse seeds and planting materials according to farmers' needs and interests easier; and (iii) facilitating seed and food sovereignty (Vernooy et al. 2014). Community seed banks are globally located in Guatemala, India, Malaysia, Mexico, Nicaragua, Sri Lanka, USA, Honduras, Bhutan, Bolivia, Brazil, Canada, Bangladesh, China, Costa Rica, Nepal, Trinidad and Tobago, Rwanda, Uganda, Mali, Burundi, Norway, Zimbabwe, and South Africa. Recently it was launched in Kenya in Nyando in smallholder farmer areas by the Consortium of International Agricultural Research Centers (CGIAR) research program on climate change agriculture and food security (CCAFS) in sub-Saharan Africa which works in partnership with Bioversity International to establish community seed banks in Kenya, Tanzania, and Uganda. The idea behind is that when you take one seed you return two, if you take five, you return ten. This protocol aids in their sustainability. The idea of community is excellent; however, the existing community seed banks are focused on cereal crops neglecting the root tuber crops. Although the International Potato Center (CIP) researchers are promoting innovative ways that allows storage of seeds of root and tuber crops.

Specifically sweet potatoes farmers are encouraged to mass-produce their own vines during planting time. The system is known as Triple S (for storing vines in sand to make them sprout). It involves storing the vines in dry sand following harvest, and thereafter planting them in seedbeds 6–8 weeks before the rainy season, and watering them to produce enough vines to plant when the rains begin. The practice results in increased vines, earlier harvests, which provides food and income at a time. In addition in order to maintain disease free planting materials, the farmers in high virus pressure zones are advised to use net tunnels systems to protect against insects such as whiteflies and aphids which are known in spreading viruses. This practice is effective in suppressing the infection rate by sweet potato virus disease thus supporting the availability of clean planting materials. According to Atakos et al. (2018), such tunnels also have contributed in moisture retention by reducing the amount of water required for irrigation. The major benefits derived from community seed banks that can be exploited for production of root and tuber crop seeds are pest and disease reduction, increased production of seeds, and climate stress buffering.

## Cropping Systems

Cropping systems plays important roles in crops adaptability to climate change since the practice encompasses on farm adaptation of improved farming technologies and in this case planting more than two crops with different maturity periods. This system has various advantages including: better utilization of the environment,



greater food yield, increased return per unit area, and insurance against crop failure. Therefore, root and tuber crops which have great flexibility can be part of such a system. This is because they can be intercropped with plantation crop such as areca nut, coconuts, coffee, rubber, and fruit crops like mangos, bananas, and litchi as these crops are adapted to the same ecological conditions (Nayar and Suja 2004). In this system, the principal crop provides cash while root intercrops provide as high-energy secondary staple to the farm family and feeds for farm animals, behave as insurance crop against risk and natural calamities, ensure food security, enhance resource use efficiency, augment net income, and increase employment opportunities.

To support this, cultivation of root and tuber such as yam, cassava, sweet potatoes, and edible aroids in the interspaces of perennial plantations such as rubber, coffee, coconut, and banana is common in tropical countries. Crops such as elephant foot yam and yam grow as intercrops horticultural and plantation crops. Also intercropping maize and yam is believed to be productive and compatible mainly because maize is a short season crop (3–4 months), while yams are long are long duration (7–12 months) crops. Sagoe (2006) also revealed that yams and cocoyams are usually cultivated in association with cocoa and furthermore new innovations propose use of cassava trees in cocoa production. Davis et al. (1986) reported that sweet potato are grown as intercrop and in rotation systems with crops like soybean, bean, sorghum, maize, and cassava. In India, cassava, yams, and edible aroids are intercropped with rubber plantations during their immature phase whereas in Malaysia cassava is grown as intercrop in Rubber estates (Leihner 1983). The cropping system also includes practices such as adjusting the planting dates, irrigation applications, and fertilizer application (Sagoe 2006). This examples suggests that when managed appropriately, cropping systems can enhance the adaptability of these crops to climate change especially when the right crops are chosen for the system.

## Irrigation Method

Climate change causes in drought which is a major abiotic factor that limit crop production. On the other hand, global warming causes rainfall fluctuations increasing the risk of plant exposure to repeated drought (Miyashita et al. 2005). Other factors ever berating the drought situation include limited fresh water bodies which cause serious issues globally, particularly in arid and semiarid regions. These fresh water bodies are also decreasing due to population pressure, comping demands from the industries, low rainfall, agricultural and urban development. Furthermore drought is considered one of the major constraints for root and tuber crop production.

Root and tuber crops have much capacity in terms of their water use efficiency and nutrient use just like other food crops. Additionally, these crops have a unique growth characteristics and functionality. Therefore a suitable irrigation method must be selected while cultivating these crops such as: an irrigation method that releases the exact amount of water required, and time and method of water application. To this end, sprinkle and trickle irrigation methods therefore becomes the best option for

these crops. This is because they save irrigation water by up 30% and 50%, respectively, as compared with surface irrigation (Al-Jamal et al. 2001). Amer (2011) revealed that in small-scale farming using gated pipes and double planting row beds, with partially wetted furrow irrigation, water saving is achieved just as in trickle irrigation. Even though partially wetted irrigation can be very useful especially because it decreases installation cost compared to trickle and sprinkle systems, in this case it is important to consider the right method for climate change adaptation. Considering this, trickle irrigation becomes the best method for these crops under the prevailing climatic conditions since it conserves water, prevents nitrogen leaching, allows deep water percolation, and reduces soil erosion. Also it gives farmers an opportunity to apply water at the right time.

## Exploiting Abandoned Lands

In this chapter, land abandonment concept is used on a land where traditional or recently agricultural activities have stopped due to their marginal characteristics. Lands are classified as abandoned when their productivity level is situated close to the margin beyond which management expenses are not compensated by the profits obtained after harvesting. To this effect, cropland abandonment has become a common occurrence globally due to the improper agricultural practices being used.

To reclaim this types of lands and to increase the arable lands, alternative crop productions (in intensive form) should be used. This is because the remaining arable land is being lost to urban and industrial uses, deforestation, rural development, such as afforestation, and land fragmentation into smaller units. According to FAO (2011), many efforts to revamp land productivity have continued over the years since the abandoned lands represents a valuable resource for crop production. Such efforts are supported by the farmers desire to pass productive farmlands onto the future generation in just a good condition as when they inherited them (Greenland et al. 1998).

Root and tuber crops can therefore be very useful for use in reclaiming these abandoned lands. This is because of their agronomic advantage such that these crops are adapted to diverse soil, environmental conditions, and a variety of farming methods with minimum agricultural input. Also, variations in the growth pattern and adopting cultural practices make them specific in production systems. In addition, these crops are relatively easy to grow since they are highly adaptable in growing at a wide range of altitudes, on both flat and sloping lands, and on both sandy and clay soils where other crops are not well adapted. Finally, the variety to choose from for these crops is very high.

All these characteristics indicates that root and tuber crops have a comparative advantage for cultivation in marginal lands than other crops since they can be selected to resist stress conditions and in contributing to sustainable crop production with low input cost. Similarly, IPGRI (2000) reported that these crops contributes to the food crops diversity and hence exploits fully the abilities of agro-ecosystems. Under this scenario of large abandoned land, root and tuber crop can be produced effectively on these lands, and after years of their production, the lands can be

returned for production of other agricultural crops production. In return this would lead to reduced clearing of additional forests and grassland for farming purposes.

## Agroforestry Practice

Agroforestry is an interaction of agriculture and trees, including the agricultural use of trees. This encompass trees on farms and in agricultural landscapes; farming in forests and along forest margins and tree-crop production including coffee and cocoa. It ranges from traditional swidden agriculture to elaborate systems of fruits trees and vines in spatial complementarity. Examples of useful agroforestry trees include; *Acacia albida*, *Leucaena leucocephala*, *Prosopis juliflora*, *Acacia scorpioides*, and *Euphorbia spp.* Others include green manure crops such as *Tephrosia spp.*, *Desmodium spp.*, *Dolichos spp.*, and *Indigofera spp.*

Some of the most promising agroforestry techniques for root and tuber crops include: (a) Scattered farm trees, this simply involves the increase in number of trees in the middle of crops and alongside the farm boundaries. The trees might have greater value than the crops they displace. Alternatively, the trees might actually increase the productivity of these crops by replenishing the soil and helping reduction of soil erosion. (b) Improved fallows, which involves fallows being enriched with fast-growing trees, vines, or shrubs. This is required by the fact that the fallow periods in many areas needs to be shortened considerably. (c) Buffer strips, which are areas of land maintained in permanent vegetation that helps control soil, air, and water quality. Root and tuber crops can therefore serve as buffers against soil erosion when planted along contour lines of slopes. In complicated systems, these root and tuber crops buffer strips can include other crop, such as grasses, trees, shrubs, and fodder legumes.

## Clean Seed Production Technologies

Policy makers acknowledges that seed security is pivotal for global food security. This is because seeds serves as the primary farm input in crop production and is also a means for conveying agricultural innovations to the farmers. Forasmuch as seeds are among the main factors that impediment crop production, these seeds must therefore be in good quality by the time they are distributed to the farmers. Actually availability, accessibility, and use of quality seeds that are adapted are of essence in increasing agricultural productivity and improving farmers livelihoods.

For clean seed production of root and tuber crops, cases reviewed encouraged seed stakeholders to emerge as permanent seed producers (Bentley et al. 2018). This would enable clean seed to flow through the value chain constantly. Methods of clean seed production include:

- (a) Commercial farms being contracted for one season, even though the method has demonstrated that it is labor intensive, it is susceptible to pests and diseases, and it is time consuming.

- (b) Tissue culture, which is the growth of tissues of plants or animal in an artificial medium separate from the parent organism. This method is very important for plant propagation for example the use of this method in seed production has ensued in mass production of clean potato seeds within a short period of time. In support of this, Pruski (2001) revealed that the method is characterized by its flexibility in terms of the rapid multiplication of seedlings. This method has been adopted in several countries like Vietnam where it revolutionized production of potato seeds. The method is now well understood and has been used in propagation of several plant species across the globe.
- (c) Aeroponic method: which is the process of cultivating plants in an air or mist environment without the use of soil or media. It is considered as one of the safest and ecological friendly method for producing natural and healthy crops. The multiplication of potatoes using this method of more advantage than other available systems. CIP (2018) reported that the method is ten times more successful than convectional techniques, hydroponics, and tissue cultures which takes much time and are more labor intensive. The method utilizes nutrient solution recirculation, thus water is not wasted and the available nutrients are used effectively. Therefore this system comparatively offers lower energy and water inputs per growing area. This system can therefore be utilized for rapid production of root and tuber crops seeds.

## Nutrient Use Efficiency (NUE)

Nutrient use efficiency indicates the ability of crops to take up and utilize nutrients for yield. The concept entails three major processes in plants: uptake, assimilation, and utilization of nutrients. The nutrient uptake and fertilizer recommendation of important root and tuber crops are presented in Table 4. This is an indicator that root and tuber crops have a higher NUE. This is support by Nieto, C. O. (2016) who

**Table 4** Nutrient uptake and fertilizer recommendation of important root and tuber crops

Crop	Tuber yield (t/ha)	Uptake (kg/ha)			Farmyard manure (t/ha)	Recommended dose (kg/ha)		
		N	P	K		N	P	K
Cassava	30	180	22	160	12.5	100	50	100
Sweet potato	14	34	6	47	5	50	25	50
Elephant foot yam	36	122	31	176	25	100	50	150
Yams	25	163	24	127	10	80	60	80
Taro	17	119	18	157	12.5	80	25	80
Tannia	20	125	37	187	25	80	50	150
Coleus	26	106	13	107	10	60	60	100
Arrow root	24	194	31	292	10	50	25	75

Source: Mohan Kumar et al. (2000)

reported that NUE of potatoes under low nitrogen input was higher than under high nitrogen input, and higher for late cultivars than for early cultivars.

---

## Conclusion

There is an urgent need to broaden the food basket of the Sub-Saharan Africa by supporting root and tuber crops cultivation through boosting their capacity to adapt to climate change. Even though these crops have been neglected, there is evidence that the crops have greater adaptability to extreme climatic conditions and that they are more resilient to both biotic and abiotic stresses. Therefore, the suggested innovations and/or adaptation measures will help in enhancing their adaptability to climate change and also to enable them to produce more harvestable yields where major crops have failed.

---

## References

- Aidoo R (2009) An analysis of yam consumption patterns in Ghanaian urban communities. The School of Graduate Studies, Kwame Nkrumah University of Science and Technology, Kumasi. PhD Thesis. Access date 03 July 2017
- Al-Jamal MS, Ball S, Sammis TW (2001) Comparison of sprinkler, trickle and furrow irrigation efficiencies for onion production. *Agric Water Manag* 46(3):253–266
- Allem C (2002) The origins and taxonomy of cassava. In: Hillocks RJ, Thresh JM, Bellotti AC (eds) *Cassava: biology, production and utilization*. CABI Publishing, Wallingford, pp 1–16
- Amer H (2011) Effect of irrigation method and quantity on squash yield and quality. *Agric Water Manag* 98:1197–1206
- Arnau G, Abraham K, Sheela M, Chair H, Sartie A, Asiedu R (2010) Yams, in root and tuber crops. In: Bradshaw J (ed) *Handbook of plant breeding*, vol 7. Springer Science + Business Media, New York, pp 127–148
- Asiedu R, Sartie A (2010) Crops that feed the world 1. Yams. *Food Secur* 2:305–315
- Atakos V (2018) Next generation technologies: tackling climate change in agriculture. Retrieved from: <https://cipotato.org/blog/next-generation-technologiestackling-climate-change-in-agriculture/>
- Atakos V, Thiele G, Campos H, Friedmann M, Holmes H, Dudenhoefer D (2018) Next generation technologies: tackling climate change in agriculture. CIP. December 5, 2018
- Augé M, Toler D, Saxton M (2015) Arbuscular mycorrhizal symbiosis alters stomatal conductance of host plants more under drought than under amply watered conditions: a meta-analysis. *Mycorrhiza* 25:13–24
- Baybutt C, Hu L, Molteni A (2000) Vitamin A deficiency injures lung and liver parenchyma and impairs function of rat type II pneumocytes. *J Nutr* 130(5):1159–1165
- Belachew T, Abera Y (2010) Response of maize (*Zea mays* L.) to tied ridges and planting methods at Goro, South eastern Ethiopia. *Am Eur J Agron* 3:21–24
- Bennett B (2015) Smallholder cassava production and the cassava processing sector in Africa. *Food Chain* 5:1–3
- Bentley JW, Andrade-Piedra J, Demo P, Dzomeku B, Jacobsen K, Kikulwe E, Ogero K (2018) Understanding root, tuber, and banana seed systems and coordination breakdown: a multi-stakeholder framework. *J Crop Improv* 32(5):599–621

- Birch J, Bryan G, Fenton B, Gilroy E, Hein I, Jones T, Prashar A, Taylor A, Torrance L, Toth K (2012) Crops that feed the world. Potato: are the trends of increased global production sustainable? *Food Secur* 4:477–508
- Carsky J, Asiedu R, Cornet D (2010) Review of soil fertility management for yam-based systems in West Africa. *Afr J Root Tuber Crops* 8:1–17
- Chen P, Rekha D, Arun B, Shen T, Lai A, Young C (2006) Phosphate solubilizing bacteria from subtropical soil and their tricalcium phosphate solubilizing abilities. *Appl Soil Ecol* 34(1):33–41
- Ciais P, Sabine C, Bala G, Bopp L, Brovkin V, Canadell J, Chhabra A, DeFries R, Galloway J, Heimann M, Jones C, Quéré L, Myneni B, Piao S, Thornton P (2013) Carbon and other biogeochemical cycles. In: Stocker TF, Qin D, Plattner G-K, Tignor M, Allen SK, Boschung J, Nauels A, Xia Y, Bex V, Midgley PM (eds) *Climate change 2013. The physical science basis. Contribution of working group I to the fifth assessment report of the intergovernmental panel on climate change*. Cambridge University Press, Cambridge, UK/New York, pp 465–570
- CIP (2017) Seed potato for Africa, [Accessed on April 12 2017] and available at <http://cipotato.org/seed-potato-for-africa/>
- CIP (2018) Potato minituber boom in Sub-Saharan Africa: tenfold increase in ten years – International Potato Center
- Codd E (1985) Lamiaceae (Labiatae). In: Leistner OA (ed) *Flora of Southern Africa*. Volume 28, Part 4. Botanical Research Institute, Pretoria. 247pp
- Coling C (1997) Effect of plastic film mulching on increasing potato yield: effect of plastic film mulching on increasing potato yield. *Acta Agric Zhojangensis* 9:83–86
- Coursey G (1981) The interactions of yam and man. *J Agric Tradit Bot Appl* 1:5–21
- Davies M, Labuschagne T, Koen E, Benesi M, Saka K (2008) Some properties of starches from cocoyam in Malawi. *Afr J Food Sci* 2:102–111
- Davis C, Wolley N, Moreno A (1986) *Multiple cropping with legumes starchy roots*. Macmillan Publishing, New York, pp 133–160
- Derpsch R, Friedrich T, Kassam A, Hongwen L (2010) Current status of adoption of no-till farming in the world and some of its main benefits. *Int J Agric Biol Eng* 3(1):1–25
- Deschenes O, Greenstone M (2006) The economic impacts of climate change: evidence from agricultural output and random fluctuations in weather. *Am Econ Rev* 97:354–385
- Development Fund (2011) *Banking for the future: savings, security and seeds*. Development Fund, Oslo. Accessed 29 Jan 2016
- Dhankher OP, Foyer CH (2018) Climate resilient crops for improving global food security and safety. *Plant Cell Environ* 41(5):877–884
- Don C (2007) No shortcuts in checking soil health. *Agric Res*. July 2007, at 4. Available at <http://www.ars.usda.gov/is/AR/archive/jul07/soil0707.pdf>. Last visited 13 Nov 2008
- Ennin A, Dapaah K, Asafu-Agyei N (2003) Land preparation for increased sweet potato production in Ghana. Paper presented at the 13th symposium of the international society for tropical root crops (ISTRC-World Branch). Held from 10th–14th November, 2003, Arusha, 14pp
- Ennin SA, Otoo E, Tetteh FM (2009) Ridging, a mechanized alternative to mounding for yam and cassava production. *West Afr J Appl Ecol* 15:1–8
- EPA (2006) *Solid waste management and greenhouse gases: a life-cycle assessment of emissions and sinks*. 55
- Erenstein O, Laxmi V (2008) Zero tillage impacts in India's rice–wheat systems: a review. *Soil Tillage Res* 100:1–14
- FAO (2000) *The state of food insecurity in the world 2000*. ISBN 92-5-104479-1 Job No. X8200/E. 36pp
- FAO (2009) FAOSTAT statistical database. Rome (available at <http://faostat.fao.org>)
- FAO (2011) *The state of the world's land and water resources for food and agriculture (SOLAW). Managing systems at risk*. FAO, Rome
- FAO. FAOSTAT (2018) Food and Agriculture Organization of the United Nations (FAO), Rome. <http://www.fao.org/faostat/>

- FAOSTAT (2017) Food and Agriculture Organization of the United Nations. Rome. <http://apps.fao.org>
- FAOSTAT (Food and Agriculture Organization Data of Statistics) (2014) Food and Agriculture Organization Data of Statistics. One hundred fifty eight countries data base. <http://faostat.fao.org/site/567/>
- Fernández R, Quiroga A, Zorati C, Noellemeyer E (2010) Carbon contents and respiration rates of aggregate size fractions under no-till and conventional tillage. *Soil Tillage Res* 109:103–109
- Foereid B, Høgh-Jensen H (2004) Carbon sequestration potential of organic agriculture in northern Europe – a modelling approach. *Nutrient Cycling in Agroecosystems* 68(1):13–24
- Graham W, Lam Y, Merckx V (2017) Plastomes on the edge: the evolutionary breakdown of mycoheterotroph plastid genomes. *New Phytol* 214:48–55
- Greenland J, Gregory J, Nye H (1998) Land resources: on the edge of the Malthusian precipice. CAB International, Wallingford
- Halvorson D, Weinhold J, Black L (2002) Tillage, nitrogen, and cropping system effects on soil carbon sequestration. *Soil Sci Soc Am J* 66:906–912
- Helgason L, Walley L, Germida J (2010) No-till soil management increases microbial biomass and alters community profiles in soil aggregates. *Appl Soil Ecol* 46:390–397
- Hillocks J, Thresh M, Bellotti C (2002) Cassava biology, production and utilization. CABI Publishing, Wallingford, p 2002
- Hunziker L, Bönisch D, Groenhagen U, Bailly A, Schulz S, Weisskopf L (2015) *Pseudomonas* strains naturally associated with potato plants produce volatiles with high potential for inhibition of *phytophthora infestans*. *Appl Environ Microbiol* 81:821–830
- IFA (1992) World fertilizer use manual. Publication of International Fertilizer Industry Association, Paris, pp 148–160
- Intergovernmental Panel on Climate Change (2007) Climate change. In: Impacts, adaptation and vulnerability. Contribution of working group II to the fourth assessment report of the intergovernmental panel on climate change. Cambridge University Press, Cambridge, UK. 976pp
- International Plant Genetic Resources Institute, (IPGRI) (2000) Enhancing the contribution of neglected and under-utilized species to food security, and to incomes of the rural poor. IPGRI, Rome
- Jarvis A, Ramirez-Villegas J, Campo H, Navarro-Racines C (2012) Is cassava the answer to African climate change adaptation? *Trop Plant Biol* 5:9–29
- Jha A, Saxena J, Sharma V (2013) Investigation on phosphate solubilization potential of agricultural soil bacteria as affected by different phosphorus sources, temperature, salt and pH. *Commun Soil Sci Plant Anal* 44:2443–2458
- Jones B, Wendt W (1994) Contribution of soil fertility research to improved maize production by smallholders in eastern and southern Africa. In: Proceedings of the fourth Eastern and Southern Africa regional maize conference 2–14
- Khan MS, Zaidi A, Wani PA (2009) Role of phosphate solubilizing microorganisms in sustainable agriculture-a review. In: Sustainable agriculture (pp. 551–570). Springer, Dordrecht
- Kintché K, Hauser S, Mahungu M, Ndonda A, Lukombo S, Nhamo N (2017) Cassava yield loss in farmer fields was mainly caused by low soil fertility and suboptimal management practices in two provinces of the Democratic Republic of Congo. *Eur J Agron* 89:107–123
- Kivuva M, Yecho G, Sibiya J, Musembi G (2014) Assessment of production constraints and farmers' preferences for sweet potato genotypes. *J Plant Breed Genet* 02(01):15–29
- Kumar A, Maurya BR, Raghuvanshi R, Meena VS, Islam MT (2017) Co-inoculation with Enterobacter and Rhizobacteria on yield and nutrient uptake by wheat (*Triticum aestivum* L.) in the alluvial soil under indo-gangetic plain of India. *J Plant Growth Regul* 36(3):608–617
- Kumwenda F (1999) The role of animal traction in soil water conservation tillage practices among smallholder farmers in Malawi. In: Kaumbutho PG, Simalenga TE (eds) Conservation tillage with animal traction. A resource book of the Animal Traction Network for Eastern and Southern Africa (ATNESA), Harare. 173pp
- Leihner D (1983) Management and evaluation of intercropping systems with cassava. CIAT, Cali

- Malik A, Sanghmitra S, Javed A (2011) Chemical vs. organic cultivation of medicinal and aromatic plants: the choice is clear. *Int J Med Arom Plants* 1(1):5–13
- Marbun S, Sembiring M, Bintang (2015) Phosphate solubilizing microbe and organic matter application to increase P uptake and potatoes growth at andisol impacted Sinabung Mountain Eruption. *J Agroekotekol* 4:1651–1658. (In Indonesian)
- Marques M (2015) Bacterial endophytes of sweet potato tuberous roots affected by the plant genotype and growth stage. *J Appl Microbiol* 96:273–281
- Miyashita K, Tanakamaru S, Maitani T, Kimura K (2005) Recovery responses of photosynthesis, transpiration and stomatal conductance in kidney bean following drought stress. *Environ Exp Bot* 53:205–214
- MoALF (2019) National root and tuber crops development strategy 2019–2022. Retrieved 12 November 2020, from <https://www.kilimo.go.ke/wp-content/uploads/2019/10/Roots-and-Tuber-Crops-Strategy-2019-2022.pdf>
- Mohan Kumar CR, Nair M, George J, Ravindran S, Ravi V (2000) Production technology of tuber crops. Central Tuber Crops Research Institute, Thiruvananthapuram, p 174
- Monneveux P, Ramirez A, Pino T (2013) Drought tolerance in potato (*S. tuberosum* L.): can we learn from drought tolerance research in cereals? *Plant Sci* 205:76–86
- Morton F (2007) The impact of climate change on smallholder and subsistence agriculture. *Proc Natl Acad Sci USA* 104(50):19680–19685
- Mostaghimi S, Gidley M, Dillaha TA, Cooke A (1994) Effectiveness of different approaches for controlling sediment and nutrient losses from eroded land. *J Soil Water Conserv* 49(6):615–620
- Motsa NM, Modi T, Mabhaudhi T (2015) Sweet Potato (*Ipomoea Batatas* L.) As a Drought Tolerant and Food Security Crop. *S Afr J Sci* 111(11/12):8. Art. #2014–0252
- Nath R, Chattopadhyay A, Kundu CK, Majumder A, Islam Sk J, Gunri S (2007) Production potential of sweet potato in the Red and Laterite ecosystem of West Bengal. *J Root Crops* 33:97–103
- Nayar R, Suja G (2004) Production potential of root and tubers in multiple cropping systems involving plantation crops. *J Root Crops* 30(2):93–100
- Naylor L, Falcon P, Goodman M, Jahn M, Sengooba T, Tefera H (2004) Biotechnology in the developing world: a case for increased investments in orphan crops. *Food Policy* 29:15–44
- Nieto CO (2016) Nitrogen use efficiency in potato: an integrated agronomic, physiological and genetic approach. Doctoral dissertation, Wageningen University
- Nugroho W (1994) Klasifikasidan Pemetaan Semi Detail Tanah Berkembangdari Abu Vulkanik-berdasarkan Sistem Taksonomi Tanah di Desa Candikuning, Baturiti, Tabanan. Skripsi. Jurusan Tanah, Fakultas Pertanian Universitas Udayana. pp 75
- Nweke FI, Spencer DSC, Lynam JK (2002) The cassava transformation: Africa's best kept secret, Michigan State University Press, East Lansing, USA. pp 273
- O'Sullivan N, Ernest J (2007) Nutrient deficiencies in lesser yam (*Dioscorea esculenta*) characterized using constant-water table sand culture. *J Plant Nutr Soil Sci* 170(2):273–282
- Okigbo N (1989) New crops for food industry: the roots and tuber in tropical Africa. In: New crops for food industry. G.E. Weekens et al, Chapman and Wall/London, pp 123–134
- Onwueme C, Sinha D (1991) Field crop production in tropical Africa: principles and practice. Technical Centre for Agriculture and Rural Cooperation, Ede. ISBN-13: 9789290810865, pp 267–275
- Onyeka J (2014) Status of cocoyam (*Colocasia esculenta* and *Xanthosoma* spp.) in west and central Africa: production, household importance and the threat from leaf blight. CGIAR Research Program on Roots, Tubers and Bananas (RTB)
- Ossom M, Pace F, Rhykerd L, Rhykerd L (2001) Effect of mulch on weed infestation, soil temperature, nutrient concentration and tuber yield in *Ipomoea batatas* in Papua New Guinea. *Trop Agric* 78:144–151
- Pinto J, Onwueme B (2000) Food values of breadfruit, taro leaves, coconut and sugar cane. FAO. Plant production and protection paper 126. FAO, Rome
- Pruski (2001) Micropropagation technology in early phases of commercial seed potato production. PhD Thesis, Wageningen University, Wageningen, p 166
- Purseglove W (1972) Monocotyledons (tropical crops S). London: Longman Group Ltd



- Purseglove W (1975) Tropical crop monocotyledonous. Longman Group, Britain
- Ramanatha V, Matthews J, Eyzaguirre B, Hunter D (2010) The global diversity of taro: ethnobotany and conservation. Biodiversity International, Rome
- Robert W, Cartwright B (2006) Potato production. Oklahoma Cooperative Extension Service, Stillwater
- Rudrappa U (2013) Yams nutrition facts and health benefits. <http://www.nutrition-and-you.com/yams.html>
- Rykaczewska K (2013) The impact of high temperature during growing season on potato cultivars with different response to environmental stresses. *Am J Plant Sci* 04:2386–2393. <https://doi.org/10.4236/ajps.2013.412295>
- Sagoe R (2006) Climate change and root crop production in Ghana. Crops Research Institute, Kumasi
- Sangakkara R, Attanayake B, Gajanayake N, Bandaranayake R (2004) Impact of mulches on growth and yields of cassava and sweet potato in tropical Asia. In: Proceedings of the 4th international crop science congress, Brisbane, 26 September–1 October 2004
- Sarma A, Dutta T, Sarma A (1999) Effect of mulching technique with black plastic film (25 u) on potato crop under rainfed condition. *Crop Res* 18:383–386
- Schübler H, Gehrig H, Schwarzott D, Walker C (2001) Analysis of partial Glomales SSU rRNA gene sequences: implications for primer design and phylogeny. *Mycol Res* 105:5–15
- Sefa-Dedeh S, Kofi-Agyir E (2002) Starch structure and some properties of cocoyam (*Xanthosoma sagittifolium* and *Colocacia esculentum*) starch and raphides. *Food Chem* 79:435–444
- Shetto M (1999) Tillage practices and soil conservation measures in Tanzania. <http://www.fao.org/ages/3ero/Harare/partii/19Sheto.htm>
- Sieverding E (1991) Vesicular-arbuscular mycorrhiza management in tropical agrosystems. Deutsche Gesellschaft für Technische Zusammenarbeit (GTZ), Eschborn. 371p
- Sombroek WG, Gommès LR (1997) Changement de climat – Agriculture. In: FAO (ed) *Changements du Climat et Production Agricole*. FAO, Rome, p 472
- Spooner DM, McLean K, Ramsay G (2005) A single domestication for potato based on multi-locus amplified fragment length polymorphism genotyping. *Proc Natl Acad Sci* 102:14694–14699
- Sriom S, Mishra P, Rajbhar P, Singh D, Singh K, Mishra K (2017) Effect of different levels of nitrogen on growth and yield in potato (*Solanum Tuberosum* L.) Cv. Kufri Khyati. *Int J Curr Microbiol App Sci* 6:1456–1460. <https://doi.org/10.20546/ijcmas.2017.608.428>
- Stokes C, Howden M (2010) Adapting agriculture to climate change: preparing australian agriculture, forestry, and fisheries for the future. CSIRO Publishing, Collingwood
- Suyamto, Howeler H (2001) Cultural practices for soil erosion control in cassava-based cropping systems in Indonesia. In: Barker DH, Watson A, Sombatpanit S, Northcutt B, Maglinao AR (eds) *International Erosion Control Association, Ground and water Bioengineering for the Asia-Pacific Region*. Science Publishers, Enfield, New Hampshire
- Tailor J, Joshi H (2014) Harnessing plant growth promoting rhizobacteria beyond nature: a review. *J Plant Nutr* 37:1534–1571
- Tshisola N (2014) Improved potato (*Solanum tuberosum* L.) seed production through aeroponics. MSc thesis, Stellenbosch University
- Udo J, Ndon A, Asuquo E, Ndaeyo U (2005) Crop production techniques for the tropics. Concept Publications, Lagos
- Ukom N, Ojimelukwe C, Okpara A (2009) Nutrient composition of selected sweet potato (*Ipomoea batatas* (L.) Lam) varieties as influenced by different levels of nitrogen fertilizer application. *Pak J Nutr* 8(11):1791–1795
- Unger W (1994) *Managing agricultural residues*. Lewis Publishers, Boca Raton. 448pp
- Uroz S, Calvaruso C, Turpault P, Frey-Klett P (2009) Mineral weathering by bacteria: ecology, actors and mechanisms. *Trends Microbiol* 17:378–387
- Vernooij R, Sthapit B, Galluzzi G, Shrestha P (2014) The multiple functions and Services of Community Seedbanks. *Resources* 4(3):636–656
- Vessey K (2003) Plant growth-promoting rhizobacteria as biofertilizers. *Plant Soil* 255:571–586
- Wiebe K (2015) Strategic foresight: long-term projections from IFPRI, GFSF and AgMIP. Presented at the 12th Meeting of the Independent Science & Partnership Council held in Rome, 16 September 2015

- Wiyu A, Kasomekerab M, Feyen J (1999) Effect of tied-ridging on soil water status of a maize crop under Malawi conditions. *Agric Water Manag* 45(2000):101–121
- Woolfe A (1992) Sweet potato, an untapped food resource. Cambridge University Press, Cambridge, UK

**Open Access** This chapter is licensed under the terms of the Creative Commons Attribution 4.0 International License (<http://creativecommons.org/licenses/by/4.0/>), which permits use, sharing, adaptation, distribution and reproduction in any medium or format, as long as you give appropriate credit to the original author(s) and the source, provide a link to the Creative Commons license and indicate if changes were made.

The images or other third party material in this chapter are included in the chapter's Creative Commons license, unless indicated otherwise in a credit line to the material. If material is not included in the chapter's Creative Commons license and your intended use is not permitted by statutory regulation or exceeds the permitted use, you will need to obtain permission directly from the copyright holder.





# Farmers' Adaptive Capacity to Climate Change in Africa: Small-Scale Farmers in Cameroon

# 5

Nyong Princely Awazi, Martin Ngankam Tchamba,  
Lucie Felicite Temgoua, and Marie-Louise Tientcheu-Avana

## Contents

Introduction .....	89
Background of the Study .....	89
Review of Literature .....	90
Perceptions of Climate Change by Small-Scale Farmers in Africa .....	90
Adverse Effects of Climate Change on Africa's Small-Scale Farmers .....	91
Drivers of Small-Scale Farmers' Vulnerability to Climate Change in Africa .....	92
Adaptation Options Implemented by Small-Scale Farmers in Africa Confronted with Climate Change .....	93
Determinants of Small-Scale Farmers' Choice of Adaptive Measures Confronted with Climate Change .....	94
Barriers to Adaptation for Small-Scale Farmers in Africa Confronted with Climate Change .....	95
Effectiveness of Small-Scale Farmers' Adaptation Measures in Enhancing Adaptive Capacity to Climate Change .....	96
Description of Study Area and Methodology .....	97
Description of the Study Area .....	97
Research Methods .....	97

This chapter was previously published non-open access with exclusive rights reserved by the Publisher. It has been changed retrospectively to open access under a CC BY 4.0 license and the copyright holder is "The Author(s)". For further details, please see the license information at the end of the chapter.

N. P. Awazi (✉) · M. N. Tchamba · L. F. Temgoua · M.-L. Tientcheu-Avana  
Department of Forestry, Faculty of Agronomy and Agricultural Sciences, University of Dschang,  
Dschang, Cameroon

Data Sources and Collection .....	97
Analysis of Data .....	98
Dependent and Independent Variables .....	98
Findings .....	98
Variations and Changes in Climate Elements .....	98
Adaptive Choices of Small-Scale Farmers Confronted with Climate Change Adversities ...	99
Farmer Perceived Factors Influencing Adaptive Capacity to Adverse Climatic Variations and Changes .....	100
Farmers' Capacity to Adapt to Climate Change .....	101
Factors Affecting Small-Scale Farmers' Adaptive Capacity to Climate Change .....	103
Discussion .....	106
Variations in Climate Elements .....	106
Adaptive Choices of Small-Scale Farmers Confronted with Climate Change .....	106
Perceived Factors Affecting Farmers' Adaptive Capacity to Climate Change .....	107
Non-Cause-Effect and Cause-Effect Relationship Between Small-Scale Farmers'	
Adaptive Capacity to Climate Change and Independent/Independent Variables .....	107
Conclusion and Policy Implications .....	108
References .....	109

## Abstract

Small-scale farmers' limited adaptive capacity confronted with the adversities of climate change is a major call for concern considering that small-scale farms feed over half of the world's population. In this light, small-scale farmers' adaptive choices and adaptive capacity to climate change were assessed. Data were collected from primary and secondary sources using a mixed research approach. Findings revealed that extreme weather events have been recurrent and small-scale farmers perceived access to land, household income, and the planting of trees/shrubs on farms (agroforestry) as the main factors influencing their capacity to adapt to climate change. Agroforestry and monoculture practices were the main adaptive choices of small-scale farmers confronted with climate change. T-test and chi-square test statistics revealed a strong non-cause-effect relationship ( $p < 0.001$ ) between small-scale farmers' capacity to adapt to climate change and different socio-economic, institutional, and environmental variables. Parameter estimates of the binomial logistic regression model indicated the existence of a strong direct cause-effect relationship ( $p < 0.05$ ) between small-scale farmers' capacity to adapt to climate change and access to credit, household income, number of farms, access to information, and access to land, indicating that these variables enhance small-scale farmers' capacity to adapt to climate change. It is recommended that policy makers examine the adaptive choices and determinants of farmers' adaptive capacity unearthed in this chapter when formulating policies geared towards enhancing small-scale farmers' capacity to adapt to climate change.

## Keywords

Climate change · Small-scale · Farmers · Adaptive capacity · Africa · Cameroon

## Introduction

### Background of the Study

The fight against climate change features prominently among the seventeen (17) United Nations Sustainable Development Goals (SDGs) – 2030 Agenda, demonstrating the desire of the global policy making community to tackle climate change, one of the foremost existential threats facing humanity today, head-on (IPCC 2018; Chanana-Nag and Aggarwal 2018; Niles and Salerno 2018). This comes in the wake of unprecedented levels of global warming caused mainly by increasing concentrations of carbon dioxide, methane, nitrous oxides, and other greenhouse gases (GHGs) in the atmosphere (Aggarwal et al. 2015; IPCC 2018). Anthropogenic activities especially excessive fossil fuel combustion, deforestation, and degradation of tropical forests have been singled out as the principal causes of the increasing emissions of greenhouse gases into the atmosphere (Biermann 2007; IPCC 2007; The Royal Society 2010; NAS and RS 2014). With the present climatic variations and changes, humanity has just two choices: adaptation and/or mitigation. With mitigation being a long-term option, adaptation becomes incumbent for different sectors of economic life especially the agricultural sector (Adger et al. 2007; Challinor and Wheeler 2008; Challinor 2009; World Bank 2013; FAO et al. 2018). With the most vulnerable actors in the agricultural sector being small-scale farmers, there is absolute necessity to promote measures that foster adaptation and enhance adaptive capacity to the adversities of climate change.

The FAO (2011) indicated that climate change will seriously threaten the livelihood of small-scale farmers. In 2016, studies demonstrated that small-scale farmers will be adversely affected by changes in climate patterns owing to their limited adaptive capacity (FAO 2016). Small-scale farmers' limited adaptive capacity when confronted with the adversities of climate change is a major call for concern considering that small-scale farmers – who in the majority are found in developing countries – contribute to the nourishment of over half of the world's population (FAO 2016). It is estimated that the developing world has roughly 500 million small-scale farms supporting about two billion people, and these small farms produce about 80% of the food consumed in Asia and sub-Saharan Africa (IFAD 2012). With the number of small-scale farms across the developing world rising (FAO 2010a, b; IPCC 2014; FAO et al. 2018), it becomes necessary to examine the capacity of small-scale farmers to adapt to climate change adversities and to examine the factors influencing the capacity of small-scale farmers to adapt to the negative effects of climate change.

Cameroon like other developing countries is dominated by food-based agricultural systems. These food-based farming systems owned in the majority by small-scale farmers (who constitute over 90% of the farming population) have been adversely affected by climate change (Molua 2006, 2008; Tingem et al. 2009; Azibo and Kimengsi 2015; Awazi 2018). Small-scale farmers' capacity to adapt to

climate change could be enhanced if human, material, logistic, and financial resources are placed at their disposal (Molua 2008; Azibo et al. 2016; Innocent et al. 2016). From this perspective, this chapter sought to assess small-scale farmers' adaptive choices and the determinants of small-scale farmers' capacity to adapt to climate change, in the hope that the findings will go a long way to influence policy and alleviate the plight of small-scale farmers.

---

## Review of Literature

### Perceptions of Climate Change by Small-Scale Farmers in Africa

Africa's small-scale farmers are increasingly perceptive of climate change, although their perceptions vary on a country-by-country basis as shown by different studies carried out in Africa. In a study carried out by Belaineh et al. (2013) in the Doba District, West Hararghe, Ethiopia, it was found that all male-headed and female-headed households perceived the occurrence of climate change. Boissière et al. (2013) on the contrary, in a study carried out in Indonesia – the tropical forests of Papua – found that the local population's perceptions of adverse climatic variations and changes differed significantly across the studied villages. They concluded that these differences in perception of climate change could be due to the different agro-ecological conditions of the villages. Mtambanengwe et al. (2012) on their part found respondents unanimous that the total quantity of rainfall had declined. The findings of Mtambanengwe et al. (2012) corroborate those of De Wit (2006) and Anderson (2007) who revealed that Southern Africa is becoming increasingly drier, threatening agricultural sustainability, as rainfall distribution within the season fluctuates tremendously.

Maddison (2006), however, found that Zimbabwe's small-scale farmers' perception of climate change varied with respect to the number of years of experience in farming. According to Maddison, small-scale farmers with more than 20 years of experience in farming were more likely to notice significant changes in normal weather patterns compared to their less experienced counterparts. This is corroborated by Mtambanengwe et al. (2012) who also found that 3–4% of small-scale farmers who claimed not to have noticed any shift in climate in the two communities studied in Zimbabwe were young farmers or farmers mostly involved in off-farm activities.

In a study undertaken in South Africa, Benhin (2006) found that about 72% of farmers sampled were of the opinion that climate change has been occurring over the years, with delays in the timing of the rain, a drastic drop in the quantity of rain, and higher temperatures. The farmers' perceptions, however, varied slightly across the nine provinces in which the study was carried out. In the semiarid areas of Tanzania, Mary and Majule (2009) found that 63.8% of farmers sampled in Kamenyanga village and 73.8% of farmers sampled in Kintinku village perceived an increase in temperature. Farmers reported that the months of September to December were becoming extremely hot and the nights were generally becoming very cold. It was

also found that most of the farmers sampled perceived a decrease in precipitation and changes in onset of rains as well as an increase in drought frequency in Kamenyanga and Kintinku districts, respectively. Most of the farmers stated that the onset of rainfall has changed because crops were usually planted in the months of October/November but lately crops are being planted in the months of December/January.

In a study undertaken in eleven (11) African countries, Maddison (2006) found that a large majority of farmers believed that precipitation is declining and temperature is on the rise. Majule et al. (2008) also reported similar findings. Tessema et al. (2013) in a study undertaken in the East Hararghe zone of Ethiopia found that farmers' perceptions differ with respect to changes in precipitation and temperature. A large majority (91.2%) of the farmers perceived a rise in temperature, whereas 3.5% and 5.3% of the farmers perceived a decrease in temperature and no change, respectively. Most of the farmers (90.3%) perceived a drop in the quantity of precipitation; meanwhile 2.6% and 6.2% of the farmers perceived an increase in the quantity of precipitation and no change, respectively. Only a small percentage (0.9%) of the farmers indicated that precipitation is variable rather than agreeing either on an increase or decrease in the quantity of rainfall.

In the same line of thought, studies undertaken across different parts of Africa have shown that small-scale farmers perceive climate change through variations in climate elements. Studies undertaken by Ishaya and Abaje (2008) in Kaduna state, Nigeria; Gbetibouo (2009) in the Limpopo Basin of South Africa; Mertz et al. (2009) in the Rural Sahel; Deressa et al. (2011) in the Nile Basin of Ethiopia; Nyanga et al. (2011) in Zambia; Nzeadibe et al. (2012) in the Niger Delta Region of Nigeria; Tambo and Abdoulaye (2012) in Nigeria; Yaro (2013) in Ghana; Juana et al. (2013) in sub-Saharan Africa (synthesis of empirical studies); Temesgen et al. (2014) in Ethiopia; Mulenga and Wineman (2014) in Zambia; and Aggarwal et al. (2015) in the Kullu District of the western Himalayan region all found that small-scale farmers were increasingly perceptive of climate change. Based on the findings of all these studies, a conclusion could be drawn to the effect that small-scale farmers' perceptions of climate change are quasi-unanimous across Africa.

## **Adverse Effects of Climate Change on Africa's Small-Scale Farmers**

Africa's small-scale farmers are increasingly being affected by climate change. Scholarship indicates that climate change has mainly adverse effects on Africa's small-scale farming communities. In a study carried out in Kenya, Herrero et al. (2010) found that climate change adversely affected small-scale farmers through recurrent droughts. Mary and Majule (2009) carried out a study in Tanzania, revealing that the recurrence of extreme climate events (changing rainfall and temperature patterns) led to increased risk of crop failure owing to the washing away of seeds and crops, stunted growth, poor seed germination, and withering of crops. It was equally found that, in the case of livestock, variations in rainfall patterns (decreased rainfall–drought and increased rainfall–floods) led to a decrease in pasture and an increase in parasites and diseases. Similar findings have been

reported by other studies carried out in Africa. Mortimore and Adams (2001), for example, found that the timing of the onset of the first rains and other intra-seasonal factors such as the effectiveness of the rains in each precipitation, and the distribution and length of the period of rain during the growing season, seriously affect crop-planting regimes as well as the effectiveness and success of farming. According to the IPCC (2007), changes in rainfall patterns and the quantity of rainfall affect soil moisture and the rate soil erosion, both prerequisites for crop growth and crop yields. All these negatively affect small-scale farmers.

In a study assessing the economic impact of climate change on agriculture in Cameroon, Molua and Lambi (2006) found that as temperature increases, and precipitation decreases, net revenue dropped across all the surveyed farms. The study equally revealed that an increase in temperature by 2.5 °C will lead to a drop in net revenues from agriculture in Cameroon by \$0.5 billion. A 5 °C increase in temperature on its part will lead to a drop in net revenues by \$1.7 billion. A 7% decrease in precipitation will lead to a drop in net revenues by \$1.96 billion, and a 14% decrease in precipitation will lead to a drop in net revenues from crops by \$3.8 billion. The study, however, found that increases in precipitation will lead to an increase in net revenues. Based on these findings, small-scale farmers in Cameroon will be adversely affected by climate change through a fall in farm revenue.

On their part, Tabi et al. (2012), in a study carried out in the Volta region of Ghana, found that climate change adversely affects rice farmers. These adverse effects were death of animals, loss of farming capital, heat stress, increase in social vices, shortage of water, slow development, and increased poverty and food insecurity. From these findings and those of other studies aforementioned, it could be said that climate change has mainly adverse or negative effects on small-scale farmers in Africa.

## **Drivers of Small-Scale Farmers' Vulnerability to Climate Change in Africa**

In the face of climate change adversities, small-scale farmers in Africa are the most vulnerable actors involved in the agricultural sector (Rurinda 2014). Small-scale farmers' vulnerability to climate change adversities could be attributed to several factors. In a study carried out to examine the vulnerability of small-scale farming systems of Zimbabwe to climate change, Rurinda (2014) and Rurinda et al. (2014) found that the main causes or sources of vulnerability of small-scale farmers to climate change were lack of knowledge, lack of draught power, increased rainfall variability, lack of seed, lack of fertilizer, and declining soil fertility. Following Rurinda's findings, the single most important source or cause of small-scale farmers' vulnerability to climate change was increasing variability in rainfall.

In a study assessing rice farming in the Volta region of Ghana, Tabi et al. (2012) showed that the main sources or causes of rice farmers' vulnerability to climate change were low price of rice in the local market, difficult land tenure system, limited or no access to credit facilities, few farmers engaged in off-farm activities, poor soils, and lack of insurance in times of crop failure.



The CDCCP (2009), in a study undertaken in the Chiredzi district of Zimbabwe, found that the main causes of small-scale farmers' vulnerability to climate change were as follows: poor farming practices, high frequency of drought, inherent dryness, limited use of climate early warning systems, over-dependence on monocropping especially maize, high incidence of poverty, population pressure, skewed ownership and access to drylands' livelihood assets such as livestock and wildlife, lack of drought preparedness plans, limited alternative livelihood options outside agriculture, and low access to technology (irrigation, seed), markets, institutions, and infrastructure (poor roads, bridges, modern energy, dams and water conveyance).

These findings therefore demonstrate that small-scale farmers in Africa are highly vulnerable to the adverse effects of climate change.

### **Adaptation Options Implemented by Small-Scale Farmers in Africa Confronted with Climate Change**

In Africa, small-scale farmers have adopted different adaptive options in order to improve their adaptive capacity confronted with climate change. Tabi et al. (2012) while assessing rice farming in the Volta region of Ghana found that rain-fed lowland rice farmers practiced different adaptive choices among which were the application of fertilizers, water management control practices, alternation of planting dates, herbicide use, and the use of high-yielding and disease-resistant varieties. On their part, Kuwornu et al. (2013) in a study carried out in northern Ghana found that small-scale farmers adopted both indigenous and introduced (modern) adaptive options to improve their adaptive capacity to climate change.

Molua and Lambi (2006), in a study undertaken in Cameroon, found that the main indigenous adaptation strategies implemented by small-scale farmers in the face of climate change were changing timing of farming operations, increasing planting space, undertaking traditional and religious ceremonies, change of crops, varying area cultivated, and cultivation of short season local varieties. The FAO (2006) found that the major indigenous adaptation strategies practiced by small-scale farmers were reducing food intake, change of crops, reducing personal expenditures, mortgaging land, homestead gardening, disposing of productive harvests, and re-sowing or re-planting.

Different authors have carried out studies across Africa with varying findings as far as indigenous adaptive choices implemented by small-scale farmers confronted with climate change adversities are concerned. For example, studies carried out by Hassan and Nhemachena (2008), the FAO (2008, 2009b), Gbetibouo (2009), and Deressa et al. (2010) showed that diversification of crops is a major indigenous strategy practiced by small-scale farmers confronted with climate change adversities. Studies carried out by Easterling et al. (2007), Boko et al. (2007), Gbetibouo (2009), the FAO (2009a, 2010c), and Deressa et al. (2010) showed that the integration of livestock to crop production is a key indigenous strategy practiced by small-scale farmers confronted with climate change. Studies undertaken by Molua and Lambi (2006), Easterling et al. (2007), Boko et al. (2007), Hassan and

Nhemachena (2008), Gbetibouo (2009), and the FAO (2009b) revealed that changing the timing of farm operations is one of the most important indigenous strategies adopted by small-scale farmers in the face of climate change. The FAO (2006, 2009b), Molua and Lambi (2006), and Gbetibouo (2009) found that changing of crops was a major adaptation strategy used by small-scale farmers to adapt to climate change. The FAO (2006) and Altieri and Koohafkan (2008) found that home gardening was a major indigenous strategy practiced by small-scale farmers confronted with climate change adversities.

The FAO (2010a), Thorlakson (2011), Rao et al. (2011), Mbow et al. (2013), Bishaw et al. (2013), Mbow et al. (2014), Kabir et al. (2015) and Awazi and Tchamba (2019), found that agroforestry practices like scattered trees on croplands, improved fallows, home gardens, and cocoa, coffee, and banana agroforests were sustainable and climate-smart adaptive choices practiced by small-scale farmers across Africa in the face of climate change.

From the foregoing, small-scale farmers are adopting both indigenous and introduced adaptive measures to adapt to the adverse effects of climate change across Africa. However, very little has been done to assess the adaptive capacity of small-scale farmers in the face of climate change.

## **Determinants of Small-Scale Farmers' Choice of Adaptive Measures Confronted with Climate Change**

Small-scale farmers' choice of adaptive measures confronted with climate change was influenced by several factors. Tabi et al. (2012), in a study carried out to assess the different adaptive choices of small-scale rice farmers in Ghana, found that the main variables influencing the different adaptive options of small-scale farmers were distance to farm and market, labor, advice from extension agents, gender, length of stay in rice farm, age, farm size, number of farms, credits, household size, and education. Deressa et al. (2008) and Atinkut and Mebrat (2016) on their part found that different infrastructural and institutional factors as well as household and farm characteristics influenced the adaptive choices of small-scale farmers confronted with adverse climatic changes. Through marginal analysis, Deressa et al. (2008), in a study carried out in the Nile Basin of Ethiopia, found that institutional factors (availability of information), social capital, household variables, agro-ecological features, and wealth attributes influenced small-scale farmers' adaptive choices confronted with climate change in the Nile Basin of Ethiopia.

Studies carried out by Maddison 2006 and Nhemachena and Hassan (2007) showed that the most common household attributes influencing small-scale farmers' adaptive capacity to climate change adversities were wealth, marital status, farming experience, age, education, and gender of the head of household; common farm attributes influencing small-scale farmers' adaptive choices to climate change included fertility, slope, and farm size; common institutional factors affecting adaptive choices of small-scale farmers to adverse climatic changes included credit accessibility and access to extension services; and the common infrastructural factor

influencing small-scale farmers' adaptive capacity to climate change was distance to input and output markets. Across Africa, different studies have been carried out assessing the impact of climate change and factors affecting small-scale farmers' adaptive choices in crop, livestock, and mixed crop-livestock production systems confronted with climate change adversities (Maddison 2006; Hassan and Nhemachena 2008; Kurukulasuriya and Mendelsohn 2007). However, Zivanomoyo and Mukarati (2012) assessed the factors affecting small-scale farmers' choice of crop varieties confronted with climate change adversities. The study sought to examine how farmers' choice of different crop varieties contributed to improve their adaptive capacity to climate change. Findings revealed that the use of more disease-resistant and hybrid varieties contributed in a major way towards enhancing the adaptive capacity of small-scale farmers to climate change.

From the foregoing, the factors influencing the adaptive choices of small-scale farmers confronted with climate change adversities could be broadly classified into institutional, environmental, and socio-economic factors. Although the factors influencing the adaptive choices of small-scale farmers confronted with climate change have been examined by different studies across Africa, little has been done to assess the small-scale farmers' adaptive capacity to climate change.

### **Barriers to Adaptation for Small-Scale Farmers in Africa Confronted with Climate Change**

In Africa, small-scale farmers have increasingly faced difficulties adapting to the adverse effects of climate change because of different factors. Tabi et al. (2012), in a study carried out on small-scale rice farmers in the Upper Volta region of Ghana, found that the main barriers to small-scale farmers' adoption of different adaptive options confronted with climate change were lack of equipment for quick and appropriate land preparation, lack of farm inputs, inadequate or no irrigation facilities, inadequate or no weather forecast, and limited access to credits. Deressa et al. (2008) in a study carried out in the Nile Basin of Ethiopia found that five major constraints affected small-scale farmers' adaptation choices to climate change. These barriers were shortage of land, shortage of labor, poor potential for irrigation, lack of money, and lack of information. The study however found that most of the constraints to small-scale farmers' adaptation to climate change could be largely attributed to poverty. Deressa et al. (2009, 2011), in studies undertaken in the Nile Basin of Ethiopia, equally demonstrated that poverty is a major barrier to small-scale farmers' adaptation to climate change, because lack of money makes it difficult for small-scale farmers to get the required resources and technologies that ease adaptation to climate change.

In a study carried out in the coastal regions of Bangladesh, Kabir et al. (2015) found that the main constraints to climate change adaptation for small-scale farmers were lack of information, lack of credit, unpredicted weather, shortage of land, shortage of farm inputs, and lack of water. Tessema et al. (2013), in a study carried out in the Eastern Hararke Zone of Ethiopia, discovered that the major constraints

to climate change adaptation for small-scale farmers were shortage of land, lack of seed, shortage of labor, limited market access, lack of money, lack of water, lack of fertilizer, lack of oxen, insecure land tenure, and lack of information. In different parts of Ethiopia, studies have shown that small-scale farmers face several difficulties in their drive to adapt to climate change (Maddison 2007; Deressa et al. 2009, 2011; Bryan et al. 2009; Mersha and Laerhoven 2016).

The aforementioned studies indicate that, small-scale farmers' inability to adapt to climate change is largely due to different barriers. However, limited work has been done to examine the adaptive capacity of small-scale farmers confronted with climate change and the barriers to small-scale farmers' capacity to adapt to climate change.

### **Effectiveness of Small-Scale Farmers' Adaptation Measures in Enhancing Adaptive Capacity to Climate Change**

In Africa, the effectiveness of small-scale farmers' adaptive choices confronted with climate change varies tremendously. Kuwornu et al. (2013) carried out a study to assess the adaptive options of small-scale farmers confronted with climate change adversities and the effectiveness of these adaptive options. They found that among the different indigenous strategies used by small-scale farmers to adapt to the adversities of climate change, the strategies comprising of timing of rainfall and early or late planting were ranked by small-scale farmers in northern Ghana as the most effective strategy used in adapting to adverse climate change while soil-related strategies were ranked as the least effective indigenous strategy used by small-scale farmers. Kuwornu et al. (2013) equally found that among the introduced adaptation strategies (adaptation strategies introduced by research), soil and plant health strategies were ranked by small-scale farmers as the most effective introduced strategy enhancing adaptation to climate change, while non-adoption of any of the introduced strategies was quasi-unanimously ranked by small-scale farmers as the least effective way of adapting to the adverse effects of changing climatic conditions. Hadgu et al. (2015) in a study undertaken in the Tigray region of northern Ethiopia found that changing of crop variety/type was ranked by small-scale farmers as the most effective adaptation strategy to climate change while the "No" adaptation strategy was the least effective way to adapt to the adversities of changing climatic conditions.

The review of previous literature enabled the authors of this chapter to understand what had been done on the African continent in general and Cameroon in particular as far as small-scale farmers' adaptation and adaptive capacity to climate change were concerned. It equally afforded the authors the opportunity to identify some independent variables used in the chapter. However, it was found that while many authors had undertaken studies which revealed that small-scale farmers adopt different adaptive choices in the face of climate change, little had been done to examine small-scale farmers' adaptive capacity to climate change. This work was therefore initiated in a bid to fill the knowledge gap.

## **Description of Study Area and Methodology**

### **Description of the Study Area**

The study was carried out in the north-west region of Cameroon. The north-west region of Cameroon lies between longitude 9°30'E to 11°15'E and latitude 5°4'N to 7°15'N. The north-west region of Cameroon covers a total surface area of about 17,812 km<sup>2</sup> and hosts a population of over 1,840,500 inhabitants, which gives a population density of roughly 103 inhabitants/km<sup>2</sup> making it one of the most densely populated regions in Cameroon. The climate is tropical, and the vegetation is mostly made up of savannah grassland, interspersed with some forest patches. The topography is rolling and characterized by mountains like Mount Oku and plains like the Ndop and Mbaw plains.

### **Research Methods**

#### **Study Site Selection and Sampling Methods**

The multiphase sampling procedure was employed. At the first phase, the area of study (the north-west region of Cameroon) was selected purposively owing to the presence of mainly small-scale farmers and the high levels of vulnerability of these small-scale farmers to climate change. At the second phase, ten villages were randomly selected from the different sub-districts found in the north-west region of Cameroon, taking into cognizance the agro-ecological, socio-economic, and environmental attributes of the different sub-districts. This was done with the help of agricultural extension agents working in the area. The third phase involved focus group discussions with small-scale farmers and key informant interviews with resource persons. This was done in order to get general information on the adaptive capacity of small-scale farmers and to triangulate this information with that gotten from small-scale farmers during household surveys. In the fourth and last phase, household surveys were conducted in the ten villages using the simple random sampling approach. With the use of semi-structured questionnaires, a total of 350 small-scale farmer household heads were sampled in the ten villages.

#### **Data Sources and Collection**

Both secondary and primary data were collected. Secondary data were collected primarily through the review of relevant literature from previous scientific studies as well as climate data from meteorological stations in the study area. Primary data were collected through a survey of 350 small-scale farmer household heads, complemented with focus group discussions, key informant interviews with resource persons, and overt observations.

Through the use of five-point Likert scale-style questions during household surveys, farmers were asked to rank their adaptive capacity to climate change

based on their livelihood capital assets. These livelihood capital assets were natural, human, social, financial, and physical. These different capital assets constituted the independent variables of the study. It was on the basis of these capital assets that farmers ranked their adaptive capacity to climate change to be high, low, or no adaptive capacity.

## **Analysis of Data**

Primary data collected on the field was coded and imputed into Microsoft Excel 2007 and SPSS 20.0 statistical packages for descriptive and inferential statistical analysis. Descriptive statistics computed were charts and percentage indices, while inferential statistics computed were t-test statistic, chi-square test, and logistic regression.

The independent samples t-test and chi-square ( $\chi^2$ ) test statistics were used to identify the non-cause-effect relationship between small-scale farmers' capacity to adapt to climate change and independent variables.

The binary logistic (BNL) regression model on its part was used to examine the cause-effect relationship between small-scale farmers' capacity to adapt to climate change and independent variables. The binary logistic regression model predicts the log ODDS of having made one decision or the other. This model permits the analysis of decisions across two categories (Di Falcao et al. 2011; Awazi and Tchamba 2018).

## **Dependent and Independent Variables**

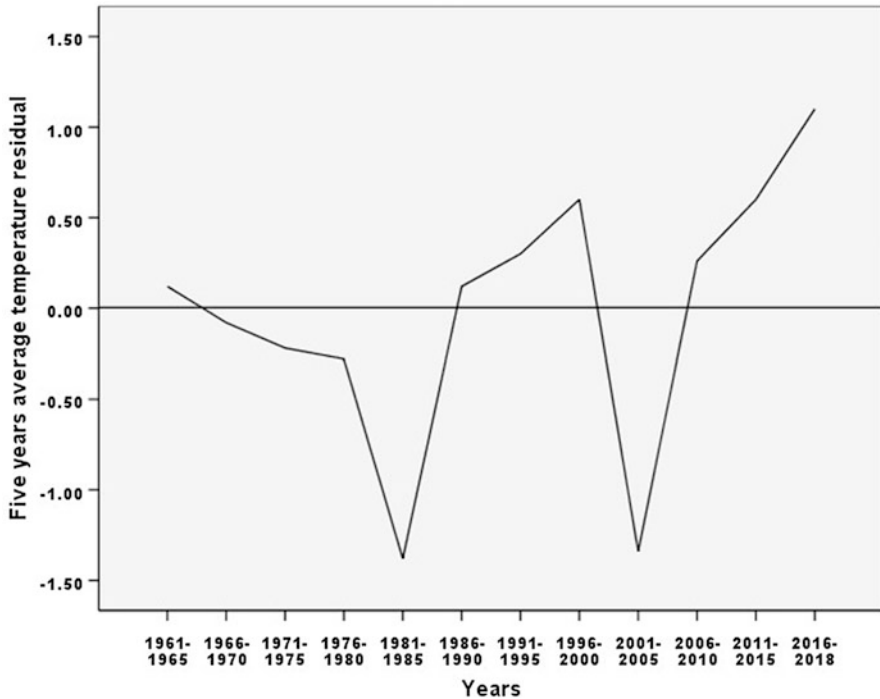
Both dependent and independent variables were used. The dependent variable was adaptive capacity (binary, i.e., adaptive/not adaptive), while the independent or independent variables (different capital assets) were age of household head, household size, number of farms, income of household, educational level, gender of household head, practice of agroforestry, vulnerability to climate change, information accessibility, credit accessibility, land accessibility, and access to extension services. Because the dependent and independent variables were mainly qualitative in nature, the statistical analyses were done using non-parametric tests and the discrete regression model (binomial logistic regression).

---

## **Findings**

### **Variations and Changes in Climate Elements**

The analysis of over five decades of climate data revealed significant variations in climate parameters (Figs. 1, 2, and 3). In the past 58 years (1961–2018), temperature fluctuations were high, and most of the years experienced above mean temperature, implying that temperature is becoming higher than usual. Meanwhile the total



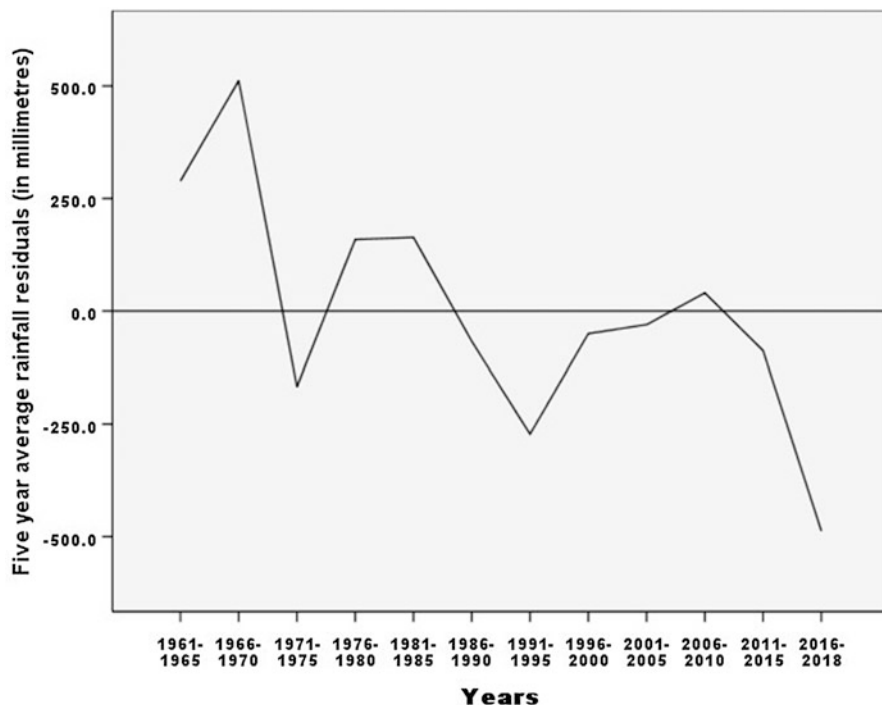
**Fig. 1** Temperature variation 1961–2018

quantity of rainfall and number of rainy days equally experienced marked levels of fluctuation, with most of the years experiencing a decrease in amount of rainfall and fewer rainy days. This indicates that the amount of rainfall has been scanty while the number of rainy days has been erratic. These high levels of fluctuation in climate parameters within the past 58 years could therefore be seen as an indicator of climatic variations and changes.

In the face of climatic variations and changes, the relationship between the different climate parameters varied. Scatter plots indicated the existence of an insignificant negative correlation between rainfall and temperature, and rainy days and temperature. Meanwhile a relatively strong positive correlation was found to exist between rainfall and rainy days.

### **Adaptive Choices of Small-Scale Farmers Confronted with Climate Change Adversities**

An analysis of small-scale farmers' adaptive choices confronted with climate change showed that a majority of the small-scale farmers (74%) were practicing agroforestry on their farm plots (Table 1). Among the agroforestry practices most patronized by



**Fig. 2** Variation in rainfall 1961–2018

small-scale farmers confronted with adverse climatic variations and changes were home gardens with livestock (13%), home garden (11%), trees on croplands (11%), live fences/hedges (11%), and coffee-based agroforestry (9%) (Table 1).

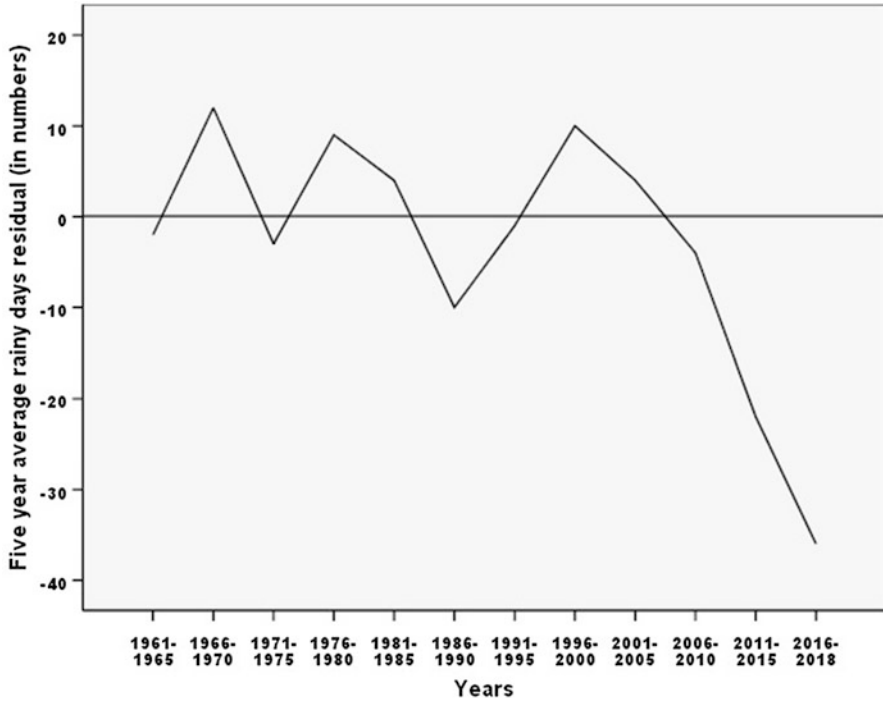
Equally, some small-scale farmers confronted with adverse climatic variations and changes practiced monoculture (Table 1). The most common monoculture and mono-livestock practices of small-scale farmers confronted with adverse climatic variations and changes were market gardening monoculture (8%), cash crop monoculture (7%), and food crops monoculture (9%).

### **Farmer Perceived Factors Influencing Adaptive Capacity to Adverse Climatic Variations and Changes**

Assessing small-scale farmers' adaptive capacity to adverse climatic variations and changes (Fig. 4), it was found that all the small-scale farmers perceived land accessibility (100%) and income of household (100%) as being the main factors influencing adaptive capacity to climate change.

Agroforestry (82%), accessibility to markets (77%), credit accessibility (72%), information accessibility (65%), and access to extension services (55%) were





**Fig. 3** Variation in rainy days 1961–2018

equally perceived by small-scale farmers as being among the key factors affecting adaptive capacity to climate change. Other least perceived factors influencing adaptive capacity to climate change were irrigation (31%) and others (14%) like road network and topography. However, it is worth mentioning that the main factors influencing small-scale farmers' adaptive capacity to climate change were land accessibility, income of household, agroforestry, accessibility to markets, credit accessibility, and information accessibility (Fig. 4).

### Farmers' Capacity to Adapt to Climate Change

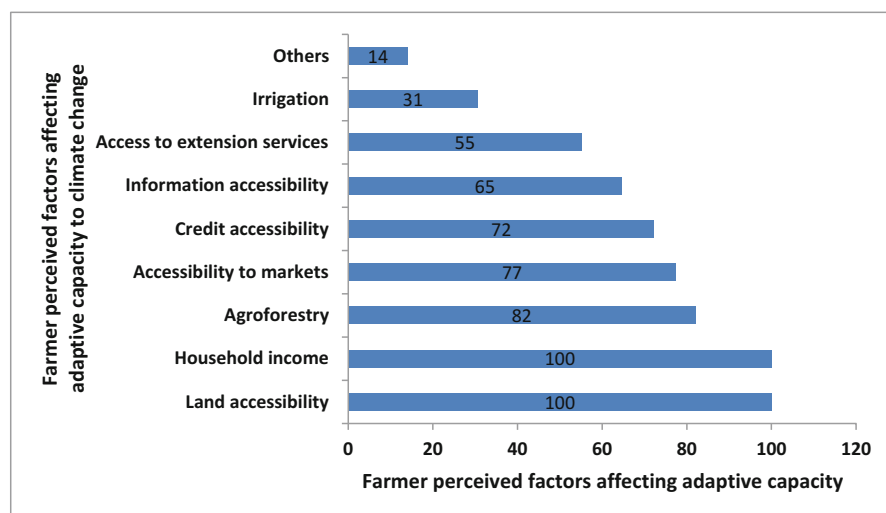
Concerning the adaptive capacity of small-scale farmers to climate change (Fig. 5), most small-scale farmers perceived that on the basis of their livelihood capital assets, they were not adaptive (58%).

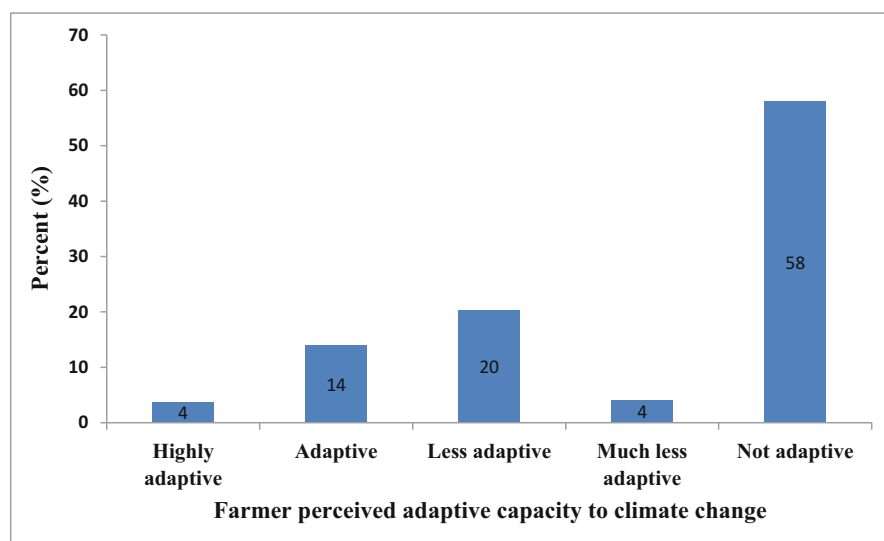
Meanwhile 14%, 20%, and 4% of small-scale farmers perceived that, on the basis of their livelihood capital assets, they were adaptive, less adaptive, and much less adaptive, respectively, to climate change. Only 4% of small-scale farmers perceived that, on the basis of their livelihood capital assets, they were highly adaptive to climate change. From these perceptions, it was noticed that most small-scale farmers had a limited capacity to adapt to climate change (Fig. 5).

**Table 1** Small-scale farmers' adaptive choices confronted with the adverse effects of climate change

Farmers' adaptive choice confronted with climate change adversity	Frequency (n)	Percent (%)
<b>1. Agroforestry practices</b>		
a. Home garden with livestock	35	13
b. Home garden	30	11
c. Trees on croplands	30	11
d. Live fences/hedges	30	11
e. Taungya	20	7
f. Trees on grazing lands	15	6
g. Improved fallows	10	4
h. Coffee-based agroforestry	25	9
i. Others (entomoforestry, aquaforestry)	5	2
<b>Total</b>	<b>200</b>	<b>74</b>
<b>2. Monoculture and mono-livestock practices</b>		
a. Market gardening crops only	20	8
b. Cash crops only	20	7
c. Food crops only	25	9
d. Livestock only	5	2
<b>Total</b>	<b>70</b>	<b>26</b>
<b>N</b>	<b>270</b>	<b>100</b>

Source: Adapted from Awazi et al. 2020

**Fig. 4** Factors influencing adaptive capacity to climate change perceived by small-scale farmers



**Fig. 5** Adaptive capacity to climate change perceived by small-scale farmers

**Table 2** Non-cause-effect relationship between small-scale farmers' adaptive capacity to climate change and four continuous independent variables

Independent variable	T-test for equality of means			
	t	df	p-level	Mean diff.
Number of farms	-10.776	170.493	0.000***	-2.940
Household size	-7.552	195.262	0.000***	-1.590
Age of household head	-8.224	209.441	0.000***	-5.192
Income of household (in FCFA)	-9.062	179.442	0.000***	-179415.9

\*\*\*Significant at 1% probability level

## Factors Affecting Small-Scale Farmers' Adaptive Capacity to Climate Change

### Non-Cause-Effect Relationship Between Small-Scale Farmers' Adaptive Capacity and Continuous Independent Variables

T-test statistics showed that there was a significant non-cause-effect relationship between small-scale farmers' adaptive capacity and four continuous independent variables (Table 2).

The continuous independent variables (number of farms ( $t = 10.776$ ,  $p < 0.001$ ), size of household ( $t = 7.552$ ,  $p < 0.001$ ), age of household head ( $t = 8.224$ ,  $p < 0.001$ ), and income of household ( $t = 9.062$ ,  $p < 0.001$ )) all had a significant non-cause-effect relationship with small-scale farmers' adaptive capacity to climate change. This demonstrates that the number of farms owned, size of household, age of

household head, and income of household play an important role in influencing the adaptive capacity of small-scale farmers confronted with climate change.

### Non-Cause-Effect Relationship Between Small-Scale Farmers' Adaptive Capacity and Qualitative Independent Variables

Chi-square test statistics showed that there was a significant non-cause-effect relationship between small-scale farmers' adaptive capacity to climate change and seven (07) qualitative independent variables (Table 3).

The qualitative independent variables (level of education of household head ( $X^2 = 123.10$ ,  $p < 0.001$ ), gender of household head ( $X^2 = 24.95$ ,  $p < 0.001$ ), practice of agroforestry ( $X^2 = 64.50$ ,  $p < 0.001$ ), information accessibility ( $X^2 = 44.70$ ,  $p < 0.001$ ), credit accessibility ( $X^2 = 90.88$ ,  $p < 0.001$ ), land accessibility ( $X^2 = 52.50$ ,  $p < 0.001$ ), and access to agricultural extension services ( $X^2 = 21.54$ ,  $p < 0.001$ )) all had a significant non-cause-effect relationship with small-scale farmers' adaptive capacity to climate change. This confirms that the level of education of household head, gender of household head, practice of agroforestry, access to information, access to credit, access to land, and access to

**Table 3** Non-cause-effect relationship between small-scale farmers' adaptive capacity and qualitative independent variables

Qualitative independent variable	Description	Frequency (n)		Percentage (%)		Chi-square	L.R.	p-level
		A.	N.A.	A.	N.A.			
Educational level of household head	No formal edu.	11	21	3.14	6	123.10	141.69	0.000***
	Primary	62	180	17.71	51.43			
	Secondary	10	0	2.86	0			
	High school	34	1	9.71	2.86			
	Tertiary	30	1	8.57	2.86			
Gender of household head	Male	104	89	29.71	25.43	24.95	25.47	0.000***
	Female	43	114	12.28	32.57			
Practice agroforestry	Yes	147	132	42	37.71	64.50	90.23	0.000***
	No	0	71	0	20.28			
Information accessibility	Yes	42	7	12	2	44.70	46.69	0.000***
	No	105	196	30	56			
Credit accessibility	Yes	64	5	18.28	1.43	90.88	99.25	0.000***
	No	83	198	23.71	56.57			
Land accessibility	Yes	51	10	14.57	2.86	52.50	54.33	0.000***
	No	96	193	27.43	55.14			
Access to extension	Yes	45	22	12.86	6.29	21.54	21.41	0.000***
	No	102	181	29.14	51.71			

\*\*\*Significant at 1% probability level; A. = adaptive; N.A. = not adaptive; L.R. = likelihood ratio

agricultural extension services influence small-scale farmers' adaptive capacity to climate change.

### Binary Logistic Regression Model Predicting Small-Scale Farmers' Adaptive Capacity to Climatic Change from Independent Variables

The parameter estimates of the binary logistic regression model revealed that five main independent variables played a statistically significant role in influencing small-scale farmers' adaptive capacity to climate changes (Table 4).

From the parameter estimates of the binary logistic regression model, the number of farms ( $\beta = 0.271, p < 0.05$ ), information accessibility ( $\beta = 0.937, p < 0.1$ ), credit accessibility ( $\beta = 1.596, p < 0.05$ ), income of household ( $\beta = 1.821, p < 0.01$ ), and land accessibility ( $\beta = 1.029, p < 0.05$ ) all had a significant direct cause-effect relationship with small-scale farmers' adaptive capacity to climate change. This implies that as the number of farms, information accessibility, credit accessibility, household income, and land accessibility increase, small-scale farmers' adaptive capacity to climate change also increases.

It is important to note that the parameter estimates of this model were valid looking at the likelihood ratio  $X^2$ , the number of cases correctly classified, and the Nagelkerke  $R^2$ . The likelihood ratio  $X^2$  ( $5, n = 350 = 145.835, p < 0.01$ ) indicated that the model was statistically significant and had a strong explanatory power. The model correctly classified up to 80% of the factors influencing small-scale farmers' adaptive capacity to climate change. Looking at the Nagelkerke  $R^2$  (Pseudo  $R^2$ ) of the model which stood at 0.648, it revealed that up to 64.8% of the changes in small-scale farmers' adaptive capacity to climate change could be explained by changes in the continuous and qualitative independent variables of the model. Hence, from the values of the likelihood ratio  $X^2$ , the number of cases correctly classified, and the Nagelkerke  $R^2$ , it could be said that the predictions of the model were very much

**Table 4** Logistic regression showing influence of independent variables on the adaptive capacity of small-scale farmers to climate change

Independent variables	Coefficients ( $\beta$ )	p-level	Std error	Wald	df	Odds ratio (Exp $\beta$ )
Constant	-1.961***	0.000	0.294	44.426	1	0.141
Number of farms	0.271**	0.003	0.092	8.690	1	1.311
Income of household	1.821***	0.002	0.614	9.064	1	5.134
Information accessibility	0.937*	0.087	0.548	2.929	1	2.553
Credit accessibility	1.596**	0.006	0.582	7.526	1	4.931
Land accessibility	1.029**	0.027	0.465	4.891	1	2.798
Log likelihood	330.37					
Likelihood ratio $X^2$	145.84***	0.000				
Nagelkerke $R^2$	0.648					
Number of cases correctly classified	80%					

\*, \*\*, \*\*\*Significant at 10%, 5%, and 1% probability levels, respectively

valid as far as determining the factors influencing small-scale farmers' adaptive capacity to climate change was concerned.

---

## Discussion

### Variations in Climate Elements

Extreme levels of variation in climate parameters (rainfall, temperature, and rainy days) have been recurrent in the north-west region of Cameroon in the past five decades which attests to climate variations and changes. Although other studies have shown the occurrence of climate variability in the north-west region of Cameroon (Innocent et al. 2016; Awazi 2018; Awazi and Tchamba 2018; Awazi et al. 2019), few studies in Cameroon have examined climatic variations using over five decades of climate data.

The chapter equally assessed the non-cause-effect and cause-effect relationship existing between climate parameters (temperature, rainy days, and rainfall) in the face of adverse climatic variations and changes. It was found that there is a very limited inverse relationship between rainfall and temperature as well as rainy days and temperature. Meanwhile a relatively strong direct relationship exists between rainfall and rainy days. This indicated that an interdependent relationship exists between rainfall and rainy days in the face of climate change. Studies carried out in other parts of the world by Chen and Wang (1995), Buishand and Brandsma (1999), Seleshi and Zanke (2004), Cong and Brady (2012), Berg et al. (2013), Olsson et al. (2015), Nkuna and Odiyo (2016), and Weng et al. (2017) have equally proven the existence of an interdependent relationship between climate parameters, although not in the context of climate change. By examining the relationship between climate parameters in the face of climate change, this chapter has filled a major knowledge gap.

### Adaptive Choices of Small-Scale Farmers Confronted with Climate Change

It was found that most small-scale farmers practice agroforestry to enhance their adaptive capacity to climate change. Agroforestry practices therefore constitute a major adaptive choice for small-scale farmers. Most studies carried out in Africa (Easterling et al. 2007; Boko et al. 2007; Hassan and Nhemachena 2008; Gbetibouo 2009; FAO 2009b, 2010; Deressa et al. 2010) have merely shown that small-scale farmers adopt indigenous and non-indigenous adaptation strategies to combat the adversities of climate change. This chapter revealed that most small-scale farmers adopt agro-ecological farming practices like agroforestry to mitigate the adverse effects of climate change, thereby filling the knowledge gap.

## **Perceived Factors Affecting Farmers' Adaptive Capacity to Climate Change**

Small-scale farmers perceived several factors influencing their adaptive capacity. Among these factors, land accessibility, income of household, and the practice of agroforestry were perceived by small-scale farmers as the most important factors affecting their adaptive capacity to climate change. As reported by other scientific studies, small-scale farmers usually perceive a combination of factors influencing their adaptation to climate variations and changes. Most studies have assessed the different adaptation choices practiced by small-scale farmers to enhance adaptive capacity to climate change (McCarthy et al. 2004; Gbetibouo and Ringler 2009; Folke et al. 2010; World Bank 2013), with very limited literature dwelling on the adaptive capacity of small-scale farmers confronted with climate change. By examining small-scale farmers' perceptions of their adaptive capacity to climate change, this chapter has filled the knowledge gap. Although some studies (Gordon 2009; Gbetibouo 2009; Thorlakson 2011) have used conceptual and theoretical approaches to assess adaptive capacity to climate change, this chapter by applying the inferential statistical approach to examine small-scale farmers' adaptive capacity to climate change adversities has filled a major knowledge gap.

## **Non-Cause-Effect and Cause-Effect Relationship Between Small-Scale Farmers' Adaptive Capacity to Climate Change and Independent/Independent Variables**

A non-cause-effect relationship was found to exist between small-scale farmers' adaptive capacity and independent variables (institutional, environmental, and socio-economic variables) like number of farms, household size, age of household head, income of household, level of education, gender, practice of agroforestry, information accessibility, credit accessibility, land accessibility, and access to extension services. Most studies undertaken across Africa and different parts of the world (McCarthy et al. 2004; Gbetibouo and Ringler 2009; Gordon 2009; Gbetibouo 2009; Folke et al. 2010; Thorlakson 2011; World Bank 2013; Awazi 2018; Awazi et al. 2019) mainly examined the non-cause-effect relationship existing between independent variables and small-scale farmers' adaptation choices to climate change. By unraveling the existence of a non-cause-effect relationship between adaptive capacity and different independent variables (institutional, environmental, and socio-economic variables), this chapter has therefore filled a knowledge gap.

A direct cause-effect relationship was found to exist between small-scale farmers' adaptive capacity and five main independent variables (credit accessibility, information accessibility, income of household, number of farms, and land accessibility). These five independent variables could therefore be considered as very important in enhancing small-scale farmers' adaptive capacity to climate change.

Thus, small-scale farmers with many farms are more adaptive to climate change which could be attributed to more yields obtained from these many farms which are consumed by the household and the excess sold to buy farm inputs. It could equally be that these farmers have more access to social and financial resources and/or better education which allows them to control more land and therefore enhanced adaptive capacity.

In the same light, small-scale farmers with better information accessibility are more adaptive to climate change than their counterparts with limited or no access which could be attributed to the fact that small-scale farmers with easy access to information are able to make plans into the future which helps them to adopt best practices.

Equally, small-scale farmers with more access to credit are more adaptive to climate change adversities than their fellow farmers with limited or no access to credit. This could be due to the fact that small-scale farmers with easy access to credit facilities are able to buy better farm inputs and can easily switch to best practices which act as a buffer to the adverse effects of climate change. Meanwhile small-scale farmers with little or no access to credit facilities are unable to buy good farm inputs and cannot switch to best practices on time which renders them weak and vulnerable in the face of climatic extremes.

Similarly, small-scale farmers with more access to land are better adaptive to climate change than their counterparts with limited or no land which can be attributed to the fact that land is an indispensable asset to any farmer, for it is the most important fixed asset, and without it, no farming activity can take place.

Some authors like McCarthy et al. (2004), Gbetibouo (2009), Thorlakson (2011), and Awazi et al. (2019) have found the existence of cause-effect relationship between small-scale farmers' adaptation choices to climate change and different independent variables. Through the use of inferential statistics to examine the cause-effect relationship between adaptive capacity and different independent variables (institutional, socio-economic, and environmental factors), this chapter fills a major knowledge gap.

---

## **Conclusion and Policy Implications**

Based on the findings of this chapter, it is clearly noticed that institutional, socio-economic, and environmental factors are key determinants of small-scale farmers' adaptive capacity to climate change. The existence of a statistically significant direct cause-effect relationship between small-scale farmers' adaptive capacity and independent variables such as credit accessibility, information accessibility, land accessibility, income of household, and number of farms is testament to the vital role these livelihood capital assets play towards enhancing small-scale farmers' adaptive capacity to climate change. Thus, it is recommended that policy makers seeking to alleviate the plight of vulnerable small-scale farmers take these determinants of small-scale farmers' adaptive capacity into consideration when



formulating policies geared towards enhancing small-scale farmers' adaptive capacity to climate change.

---

## References

- Adger WN, Agrawala S, Mirza MMQ, Conde C, O'Brien K, Puhlin J, Pulwarty R, Smit B, Takahashi K (2007) Assessment of adaptation practices, options, constraints and capacity. In climate change 2007: impacts, adaptation and vulnerability. Contribution of Working Group II to the fourth assessment of the IPCC, Palutikof JP, van der Linden PJ, Hansen CE (eds). Cambridge University Press, Cambridge. <http://www.ipcc-wg2.gov/AR4/website/17.pdf>
- Aggarwal VRK, Mahajan PK, Negi YS, Bhardwaj SK (2015) Trend analysis of weather parameters and people perception in Kullu District of Western Himalayan region. *Environ Ecol Res* 3 (1):24–33. <https://doi.org/10.13189/eer.2015.030104>
- Altieri MA, Koohafkan P (2008) Enduring farms: climate change, small-scales and traditional farming communities. Environment and development series 6. Third world network. Penang, Malaysia. [http://www.fao.org/nr/water/docs/enduring\\_farms.pdf](http://www.fao.org/nr/water/docs/enduring_farms.pdf)
- Anderson J (2007) How much did property rights matter? Understanding food insecurity in Zimbabwe: a critique of Richardson. *Afr Aff* 106(425):681–690. <https://doi.org/10.1093/afraf/adm064.pdf>
- Atinkut B, Mebrat A (2016) Determinants of farmers' choice of adaptation to climate variability in Dera Woreda, South Gondar Zone, Ethiopia. *Environ Syst Res* 5:6. <http://link.springer.com/content/pdf/10.1186%2Fs40068-015-0046-x.pdf>
- Awazi NP (2018) Adaptation options enhancing farmers' resilience to climate change. LAP LAMBERT Academic, 132 p. ISBN-10: 3330027940; ISBN-13: 978-3330027947
- Awazi NP, Tchamba NM (2018) Determinants of small-scale farmers' adaptation decision to climate variability and change in the north-west region of Cameroon. *Afr J Agric Res* 13:534–543
- Awazi NP, Tchamba NM (2019) Enhancing agricultural sustainability and productivity under changing climate conditions through improved agroforestry practices in small-scale farming systems in sub-Saharan Africa. *Afr J Agric Res* 14(7):379–388
- Awazi NP, Tchamba NM, Tabi FO (2019) An assessment of adaptation options enhancing small-scale farmers' resilience to climate variability and change: case of Mbengwi Central sub-Division, the north-west region of Cameroon. *Afr J Agric Res* 14(6):321–334
- Awazi NP, Tchamba NM, Temgoua LF (2020) Enhancement of resilience to climate variability and change through agroforestry practices in smallholder farming systems in Cameroon. *Agrofor Syst* 94:687–705. <https://doi.org/10.1007/s10457-019-00435-y>
- Azibo BR, Kimengsi JN (2015) Building an indigenous agro-pastoral adaptation framework to climate change in sub-Saharan Africa: experiences from the the north-west region of Cameroon. *Procedia Environ Sci* 29:126–127
- Azibo BR, Kimengsi JN, Buchenrieder G (2016) Understanding and building on indigenous agro-pastoral adaptation strategies for climate change in sub-Saharan Africa: experiences from rural Cameroon. *J Adv Agric* 6(1):833–840. <https://doi.org/10.24297/jaa.v6i1.5391>
- Belaineh L, Ayele Y, Bewket W (2013) Smallholder farmers' perceptions and adaptation to climate variability and change in Doba District, West Hararghe, Ethiopia. *Asian J Empir Res* 3(3):251–265. <http://www.aessweb.com/download.php?id=1838.pdf>
- Benhin J (2006) Climate change and South African agriculture: impacts and adaptation options. CEEPA discussion paper no 21, July 2006. <https://www.weadapt.org/sites/weadapt.org/files/legacy-new/knowledge-base/files/5370f181a5657504721bd5c21csouth-african-agriculture.pdf>
- Berg P, Moseley C, Haerter JO (2013) Strong increase in convective precipitation in response to higher temperatures. *Nat Geosci* 6:181–185

- Biermann F (2007) Earth system governance as a crosscutting theme of global change research. *Global Environ Chang* 17(2007):326–337. <http://www.glogov.org/images/doc/Biermann%202007%20GEC%20Earth%20System%20Governance.pdf>
- Bishaw B, Neufeldt H, Mowo J, Abdelkadir A, Muriuki J, Dalle G, Assefa T, Guillozet K, Kassa H, Dawson IK, Luedeling E, Mbow C (2013) Farmers' strategies for adapting to and mitigating climate variability and change through agroforestry in Ethiopia and Kenya. Davis CM, Bernart B, Dmitriev A (eds). Forestry Communications Group, Oregon State University, Corvallis. [http://international.oregonstate.edu/files/final\\_report\\_agroforestry\\_synthesis\\_paper\\_3\\_14\\_2013.pdf](http://international.oregonstate.edu/files/final_report_agroforestry_synthesis_paper_3_14_2013.pdf)
- Boissière M, Locatelli B, Sheil D, Padmanaba M, Sadjudin E (2013) Local perceptions of climate variability and change in tropical forests of Papua, Indonesia. *Ecol Soc* 18(4):13
- Boko M, Niang I, Nyong A, Vogel C, Githeko A, Medany M, Osman-Elasha B, Tabo R, Yanda P (2007) Africa. Climate change 2007: impacts, adaptation and vulnerability. Contribution of Working Group II to the fourth assessment report of the Intergovernmental Panel on Climate Change, Parry ML, Canziani OF, Palutikof JP, van der Linden PJ, Hanson CE (eds). Cambridge University Press, Cambridge, UK, pp 433–467. <https://www.ipcc.ch/pdf/assessment-report/ar4/wg2/ar4-wg2-chapter9.pdf>
- Bryan E, Deressa TT, Gbetibouo GA, Ringler C (2009) Adaptation to climate change in Ethiopia and South Africa: options and constraints. *Environ Sci Policy* 12:413–426. <https://www.researchgate.net/publication/222015072.pdf>
- Buishand TA, Brandsma T (1999) Dependence of precipitation on temperature at Florence and Livorno (Italy). *Clim Res* 12:53–63
- CDCCP Synthesis Report (2009) Coping with drought and climate change project: case of the Chiredzi district of Zimbabwe. [http://adaptation-undp.org/sites/default/files/downloads/cwd\\_va\\_synthesis\\_report.pdf](http://adaptation-undp.org/sites/default/files/downloads/cwd_va_synthesis_report.pdf)
- Challinor AJ (2009) Developing adaptation options using climate and crop yield forecasting at seasonal to multi-decadal timescales. *Environ Sci Policy* 12(4):453–465. ISSN 0168-1923
- Challinor AJ, Wheeler TR (2008) Crop yield reduction in the tropics under climate change: processes and uncertainties. *Agric For Meteorol* 148:343–356
- Chanana-Nag N, Aggarwal PK (2018) Woman in agriculture, and climate risks: hotspots for development. *Clim Chang*. <https://doi.org/10.1007/s10584-018-2233-z>
- Chen Y-L, Wang J-J (1995) The effects of precipitation on the surface temperature and airflow over the island of Hawaii. *Am Meteorol Soc* 123:681–694
- Cong R-G, Brady M (2012) The interdependence between rainfall and temperature: copula analyses. *Sci World J* 2012:405675, 11 pages. <https://doi.org/10.1100/2012/405675>
- De Wit M (2006) Measuring the economic impacts of climate change on crop farming in Africa. Climate change and African agriculture policy note no 8. CEEPA, University of Pretoria, Pretoria
- Deressa T, Hassan RM, Alemu T, Yesuf M, Ringler C (2008) Analyzing the determinants of farmers' choice of adaptation methods and perceptions of climate change in the Nile Basin of Ethiopia. IFPRI discussion paper 00798. International Food Policy Research Institute, Washington, DC, 26 p. <https://core.ac.uk/download/pdf/6337745.pdf>
- Deressa TT, Hassan RM, Ringler C, Alemu T, Yesuf M (2009) Determinants of farmers' choice of adaptation methods to climate change in the Nile Basin of Ethiopia. *Glob Environ Chang* 19:248–255. <http://www.sciencedirect.com/science/article/pii/S0959378009000156.pdf>
- Deressa TT, Ringler C, Hassan RM (2010) Factors affecting the choices of coping strategies for climate extremes: the case of farmers in the Nile Basin of Ethiopia. IFPRI discussion paper no. 01032. International Food Policy Research Institute, Washington, DC, 25 pp. <http://ebrary.ifpri.org/cdm/ref/collection/p15738coll2/id/5198.pdf>
- Deressa TT, Hassan RM, Ringler C (2011) Perception of and adaptation to climate change by farmers in the Nile Basin of Ethiopia. *J Agric Sci* 149:23–31
- Di Falco S, Veronesi M, Yesuf M (2011) Does adaptation to climate change provide food security? A micro-perspective from Ethiopia, *am. J Agric Econ* 93(3):829–846. <https://doi.org/10.1093/ajae/aar006>

- Easterling WE, Aggarwal PK, Batima P, Brander KM, Erda L, Howden SMA, Kirilenko A, Morton J, Soussana JF, Schmidhuber J, Tubiello FN (2007) Food, fibre and forest products. Climate Change 2007: Impacts, adaptation and vulnerability. Contribution of Working Group II to the fourth assessment report of the Intergovernmental Panel on Climate Change, Parry ML, Canziani OF, Palutikof JP, van der Linden PJ, Hanson CE (eds). Cambridge University Press, Cambridge, UK, pp 273–313. <https://www.ipcc.ch/pdf/assessment-report/ar4/wg2/ar4-wg2-chapter5.pdf>
- FAO, IFAD, UNICEF, WFP, WHO (2018) The state of food security and nutrition in the world 2018. Building climate resilience for food security and nutrition. FAO, Rome. Licence: CC BY-NC-SA 3.0 IGO
- Folke C, Carpenter SR, Walker B, Scheffer M, Chapin T, Rockström J (2010) Resilience thinking: integrating resilience, adaptability and transformability. *Ecol Soc* 15(4):20. [Online]. URL: <http://www.ecologyandsociety.org/vol15/iss4/art20.pdf>
- Food and Agriculture Organization (FAO) (2006) Livelihood Adaptation to climate variability and change in drought-prone areas of Bangladesh, Rome, p 97. <ftp://ftp.fao.org/docrep/fao/009/a0820e/a0820e.pdf>
- Food and Agriculture Organization (FAO) (2008) Climate change adaptation and mitigation in the food and agriculture sector. High Level Conference on World Food Security – background paper HLC/08/BAK/1. <ftp://ftp.fao.org/docrep/fao/meeting/013/ai782e.pdf>
- Food and Agriculture Organization (FAO) (2009a) Profile for climate change, Rome, 28 pp. <ftp://ftp.fao.org/docrep/fao/012/i1323e/i1323e00.pdf>
- Food and Agriculture Organization (FAO) (2009b) Climate change and agriculture policies; How to mainstream climate change adaptation and mitigation into agriculture policies, Rome, 76 pp. [http://www.fao.org/fileadmin/templates/ex\\_act/pdf/Climate\\_change\\_and\\_agriculture\\_policies\\_EN.pdf](http://www.fao.org/fileadmin/templates/ex_act/pdf/Climate_change_and_agriculture_policies_EN.pdf)
- Food and Agriculture Organization (FAO) (2010a) Homestead gardens in Bangladesh. Technology for agriculture. Proven technologies for small holders. <http://www.fao.org/teca/content/homestead-gardens-bangladesh.pdf>. Accessed 26 October 2014
- Food and Agriculture Organization (FAO) (2010b) Incorporation of tree management into land management in Jamaica – guinea grass mulching. Technology for agriculture. Proven technologies for small holders. <http://www.fao.org/teca/content/incorporation-tree-management-land-management-jamaica-%C2%BF-guinea-grass-mulching.pdf>
- Food and Agriculture Organization (FAO) (2010c) Collaborative change; a communication framework for climate change adaptation and food security, Rome, 47 pp. <http://www.fao.org/docrep/012/i1533e/i1533e00.pdf>
- Food and Agriculture Organization (FAO) (2011) Framework programme on climate change adaptation, Fao-Adapt. <http://www.fao.org/docrep/014/i2316e/i2316e00.pdf>
- Food and Agriculture Organization (FAO) (2016) Climate change and food security: risks and responses. <http://www.fao.org/3/a-i5188e.pdf>
- Gbetibouo AG (2009) Understanding farmers' perceptions and adaptations to climate change and variability: the case of the Limpopo Basin, South Africa. IFPRI discussion paper no. 00849. International Food Policy Research Institute, Washington, DC, 36 pp. <http://www.ifpri.org/publication/understanding-farmers-perceptions-and-adaptations-climate-change-and-variability.pdf>
- Gbetibouo GA, Ringer C (2009) Mapping South African farming sector vulnerability to climate change and variability; a sub national assessment. IFPRI discussion paper 00885. <http://www.ifpri.org/publication/mapping-south-african-farming-sector-vulnerability-climate-change-and-variability.pdf>
- Gordon CR (2009) The science of climate change in Africa: impacts and adaptation, Grantham Institute for Climate Change, discussion paper N<sup>o</sup> 1. Imperial College London, [https://workspace.imperial.ac.uk/climatechange/public/pdfs/discussion\\_papers/Grantham\\_Institut\\_-\\_The\\_science\\_of\\_climate\\_change\\_in\\_Africa.pdf](https://workspace.imperial.ac.uk/climatechange/public/pdfs/discussion_papers/Grantham_Institut_-_The_science_of_climate_change_in_Africa.pdf)
- Hadgu G, Tesfaye K, Mamo G, Kassa B (2015) Farmers' climate change adaptation options and their determinants in the Tigray region, northern Ethiopia. *Afr J Agric Res* 10(9):956–964. <http://www.academicjournals.org/journal/AJAR/article-full-text/9A1563251045.pdf>

- Hassan R, Nhemachena C (2008) Determinants of African farmers' strategies for adapting to climate change: multinomial choice analysis. *Afr J Agric Resour Econ* 2(1):83–104. <http://ageconsearch.umn.edu/bitstream/56969/2/0201%20Nhemachena%20%26%20Hassan%20-%2026%20may.pdf>
- Herrero M, Ringler C, van de Steeg J, Thornton P, Zhu T, Bryan E, Omolo A, Koo J, Notenbaert A (2010) Climate variability and climate change: impacts on Kenyan agriculture. International Food Policy Research Institute, Washington, DC. <https://cgspace.cgiar.org/bitstream/handle/10568/3840/climateVariability.pdf>
- Innocent NM, Bitondo D, Azibo BR (2016) Climate variability and change in the Bamenda highlands of the north-west region of Cameroon: perceptions, impacts and coping mechanisms. *Br J Appl Sci Technol* 12(5):1–18
- Intergovernmental Panel on Climate Change (IPCC) (2007) Climate change 2007: impacts, adaptation and vulnerability. Summary for policymakers, IPCC AR4 WGII. Cambridge University Press, Cambridge, UK. <https://www.ipcc.ch/pdf/assessment-report/ar4/wg2/ar4-wg2-spm.pdf>
- International Fund for Agricultural Development (IFAD) (2012) Sustainable small-scale agriculture: feeding the world, protecting the planet. Proceedings of the Governing Council Events. In conjunction with the thirty-fifth session of IFAD's Governing Council, February 2012. <https://www.ifad.org/documents/10180/6d13a7a0-8c57-42ec-9b01-856f0e994054.pdf>
- IPCC, (2014). Climate change 2014: synthesis report. Contribution of working groups I, II and III to the fifth assessment report of the Intergovernmental Panel on Climate Change [Core Writing Team, Pachauri RK, Meyer LA (eds)]. IPCC, Geneva, 151 pp. [https://www.ipcc.ch/pdf/assessment-report/ar5/syr/SYR\\_AR5\\_FINAL\\_full.pdf](https://www.ipcc.ch/pdf/assessment-report/ar5/syr/SYR_AR5_FINAL_full.pdf)
- IPCC (2018) Summary for policymakers. In: Masson-Delmotte V, Zhai P, Pörtner HO, Roberts D, Skea J, Shukla PR, Pirani A, Moufouma-Okia W, Péan C, Pidcock R, Connors S, Matthews JBR, Chen Y, Zhou X, Gomis MI, Lonnoy E, Maycock T, Tignor M, Waterfield T (eds) Global warming of 1.5°C. An IPCC special report on the impacts of global warming of 1.5°C above pre-industrial levels and related global greenhouse gas emission pathways, in the context of strengthening the global response to the threat of climate change, sustainable development, and efforts to eradicate poverty. World Meteorological Organization, Geneva, 32 pp
- Ishaya S, Abaje IB (2008) Indigenous people's perception on climate change and adaptation strategies in Jema'a local government area of Kaduna state. *Nigeria J Geogr Reg Plann* 1 (8):138–143
- Juana JS, Zibanani K, Okurut FN (2013) Farmers' perceptions and adaptations to climate change in sub-Saharan Africa: a synthesis of empirical studies and implications for public policy in African agriculture. *J Agric Sci* 5:121–135
- Kabir KH, Billah MM, Sarker MA, Miah MAM (2015) Adaptation of farming practices by small-scale farmers in response to climate change. *J Agric Ext Rural Dev* 7(2):33–40. <http://www.academicjournals.org/journal/JAERD/article-full-text/EB533A551012>
- Kurukulasuriya P, Mendelsohn R (2007) Crop selection: adapting to climate change in Africa. World Bank policy research working paper 4307, Sustainable Rural and Urban Development Team. <http://library1.nida.ac.th/worldbankf/fulltext/wps04307.pdf>
- Kuwornu MKJ, Hassan MR, Etwire MP, Osei-Owusu Y (2013) Determinants of choice of indigenous climate related strategies by small-scale farmers in northern Ghana. *British Journal of Environment and Climate Change* 3(2):172–187. <http://www.sciencedomain.org/review-history.php?iid=251&id=10&aid=1785.pdf>
- Maddison D (2006) The perception of and adaptation to climate change in Africa. Centre for Applied Environmental Economics and Policy in Africa (CEEPA). Discussion paper no 10. CEEPA, University of Pretoria, Pretoria. <http://www.ceepa.co.za/uploads/files/CDP10.pdf>
- Maddison D (2007) Perception and adaptation to climate change in Africa. Policy research working paper, 4308
- Majule AE, Ngongondo C, Kallanda-Sabola M, Lamboll R, Stathers T, Liwenga E, Ngana OJ (2008) Strengthening local agricultural innovation systems in less and more favoured areas of Tanzania and Malawi to adapt to climate change and variability: perceptions. Impacts,

- vulnerability and adaptation. Res. Abstracts. Issue Number 3: Sokoine University of Agric.: ISBN: 9987-38-9
- Mary AL, Majule AE (2009) Impacts of climate change, variability and adaptation strategies on agriculture in semi arid areas of Tanzania: the case of Manyoni District in Singida region, Tanzania. *Afr J Environ Sci Technol* 3(8):206–218
- Mbow C, Smith P, Skole D, Duguma L, Bustamante M (2013) Achieving mitigation and adaptation to climate change through sustainable agroforestry practices in Africa. *Curr Opin Environ Sustain* 6:8–14. 2014. [http://ac.els-cdn.com/S1877343513001255/1-s2.0-S1877343513001255-main.pdf?\\_tid=84bce8a4-ea32-11e5-ab6e-00000aab0f6b&acdnat=1457994020\\_73ea11926686e4ef3ccb03abel829c42](http://ac.els-cdn.com/S1877343513001255/1-s2.0-S1877343513001255-main.pdf?_tid=84bce8a4-ea32-11e5-ab6e-00000aab0f6b&acdnat=1457994020_73ea11926686e4ef3ccb03abel829c42)
- Mbow C, Noordwijk MV, Luedeling E, Neufeldt H, Minang PA, Kowero G (2014) Agroforestry solutions to address food security and climate change challenges in Africa. *Curr Opin Environ Sustain* 6:61–67. [http://ac.els-cdn.com/S1877343513001449/1-s2.0-S1877343513001449-main.pdf?\\_tid=45e8adc0-ea32-11e5-9b7f-00000aacb35f&acdnat=1457993914\\_1fcfb75960e7afcce80d0f1082f300e](http://ac.els-cdn.com/S1877343513001449/1-s2.0-S1877343513001449-main.pdf?_tid=45e8adc0-ea32-11e5-9b7f-00000aacb35f&acdnat=1457993914_1fcfb75960e7afcce80d0f1082f300e)
- McCarthy J, Martello J, Marybeth L (2004) Climate change in the context of multiple stressors and resilience. ACIA scientific report. Cambridge University Press, pp 945–983. [www.acia.uaf.edu/PDFs/ACIA\\_Science\\_Chapters\\_Final/ACIA\\_Ch17\\_Final.pdf](http://www.acia.uaf.edu/PDFs/ACIA_Science_Chapters_Final/ACIA_Ch17_Final.pdf)
- Mersha AA, Laerhoven FV (2016) A gender approach to understanding the differentiated impact of barriers to adaptation: responses to climate change in rural Ethiopia. *Reg Environ Chang*. <https://doi.org/10.1007/s10113-015-0921-z>
- Mertz O, Mbow C, Reenberg A, Diouf A (2009) Farmers' perceptions of climate change and agricultural adaptation strategies in rural Sahel. *Environ Manag* 43(5):804–816
- Molua EL (2006) Climate trends in Cameroon: implications for agricultural management. *Clim Res* 30:255–262
- Molua EL (2008) Turning up the heat on African agriculture: the impact of climate change on Cameroon's agriculture. *AfJARE* 2(1):–20. <http://ageconsearch.umn.edu/bitstream/56967/2/0201%20si%20malua%20-%2026%20may.pdf>
- Molua EL, Lambi CM (2006) The economic impact of climate change on agriculture in Cameroon. In CEEPA discussion paper no. 17
- Mortimore MJ, Adams WM (2001) Farmer adaptation, change and crisis in the Sahel. *Glob Environ Chang* 11:49–57
- Mtambanengwe F, Mapfumo P, Chikowo R, Chamboko T (2012) Climate change and variability: small-scale farming communities in Zimbabwe portray a varied understanding. *African Crop Science Journal* 20(Suppl 2):227–241. <http://www.bioline.org.br/pdf?cs12041pdf>
- Mulenga BP, Wineman A (2014) Climate trends and farmers' perceptions of climate change in Zambia. Working paper no. 86 September 2014. Indaba Agricultural Policy Research Institute (IAPRI) Lusaka, Zambia. [http://fsg.afre.msu.edu/zambia/wp86\\_rev.pdf](http://fsg.afre.msu.edu/zambia/wp86_rev.pdf)
- National Academy of Sciences (NAS) and the Royal Society (RS) (2014) Climate change, evidence and causes. An overview from the Royal Society and an the United States Academy of Sciences. <http://dels.nas.edu/resources/static-assets/exec-office-other/climate-change-full.pdf>
- Nhemachena C, Hassan R (2007) Micro-level analysis of farmers' adaptation to climate change in southern Africa. IFPRI discussion paper no. 00714. International Food Policy Research Institute, Washington, DC, 30 pp. [https://ipcc-wg2.gov/njlite\\_download2.php?id=8035pdf](https://ipcc-wg2.gov/njlite_download2.php?id=8035pdf)
- Niles MT, Salerno JD (2018) A cross-country analysis of climate shocks and small-scale food insecurity. *PLoS One* 13(2):e0192928. <https://doi.org/10.1371/journal.pone.0192928>
- Nkuna TR, Odiyo JO (2016) The relationship between temperature and rainfall variability in the Levubu sub-catchment, South Africa. *Int J Environ Sci* 1:66–75. <http://iaras.org/iaras/journals/ijes>
- Nyanga PH, Johnsen FH, Aune JB, Kalinda TH (2011) Small-scale farmers' perceptions of climate change and conservation agriculture: evidence from Zambia. *J Sustain Dev* 4(4):73–85
- Nzeadibe TC, Egbule CL, Chukwuone NA, Agwu AE, Agu VC (2012) Indigenous innovations for climate change adaptation in the Niger Delta region of Nigeria. *Environ Dev Sustain* 14(6):901–914

- Olsson T, Jakkila J, Veijalainen N, Backman L, Kaurola J, Vehviläinen B (2015) Impacts of climate change on temperature, precipitation and hydrology in Finland – studies using bias corrected Regional Climate Model data. *Hydrol Earth Syst Sci* 19:3217–3238. <https://doi.org/10.5194/hess-19-3217-2015>
- Rao KPC, Ndegwa WG, Kizito K, Oyoo A (2011) Climate variability and change: farmer perceptions and understanding of intra-seasonal variability in rainfall and associated risk in semi-arid Kenya. *Exp Agric* 47:267–291. <https://doi.org/10.1017/S0014479710000918>
- Rurinda JP (2014) Vulnerability and adaptation to climate variability and change in small-scale farming systems in Zimbabwe. Thesis submitted in fulfillment of the requirements for the Degree of Doctor at Wageningen University, and publicly defended on Tuesday 10 June 2014 at 11 a.m. in the Aula. <http://edepot.wur.nl/305159pdf>
- Rurinda JP, Mapfumo P, Van Wijk MT, Mtambanengwe F, Rufino MC, Chikowo R, Giller KE (2014) Sources of vulnerability to a variable and changing climate among small-scale households in Zimbabwe: a participatory analysis. *Clim Risk Manag* 3:65–78
- Seleshi Y, Zanke U (2004) Recent changes in rainfall and rainy days in Ethiopia. *Int J Climatol* 24:973–983
- Tabi FO, Adiku SGK, Kwadwo O, Nhamo N, Omoko M, Atika E, Mayebi A (2012) Perceptions of rain-fed lowland rice farmers on climate change, their vulnerability, and adaptation strategies in the Volta region of Ghana. *Technol Innov Dev*. [https://doi.org/10.1007/978-2-8178-0268-8\\_12](https://doi.org/10.1007/978-2-8178-0268-8_12)
- Tambo JA, Abdoulaye T (2012) Climate change and agricultural technology adoption: the case of drought tolerant maize in rural Nigeria. *Mitig Adapt Strateg Glob Chang* 17:277–292. <http://link.springer.com/article/10.1007%2Fs11027-011-9325-7html>
- Temesgen D, Yehualashet H, Rajan DS (2014) Climate change adaptation of small-scale farmers in south eastern Ethiopia. *J Agric Ext Rural Dev* 6(11):354–366
- Tesemma YA, Aweke CS, Endris GS (2013) Understanding the process of adaptation to climate change by small-scale farmers: the case of East Hararge zone, Ethiopia. *Agric Food Econ* 1:13. <http://agrifoodecon.springeropen.com/articles/10.1186/2193-7532-1-13>
- The Royal Society (2010). Climate change: a summary of the science, September 2010. [https://royalsociety.org/~media/Royal\\_Society\\_Content/policy/publications/2010/4294972962.pdf](https://royalsociety.org/~media/Royal_Society_Content/policy/publications/2010/4294972962.pdf)
- Thorlakson T (2011) Reducing subsistence farmers' vulnerability to climate change: the potential contributions of agroforestry in western Kenya, occasional paper 16. World Agroforestry Centre, Nairobi. <http://www.worldagroforestry.org/downloads/Publications/PDFS/OP11183.pdf>
- Tingem M, Rivington M, Bellocchi G (2009) Adaptation assessments for crop production in response to climate change in Cameroon. *Agron Sustain Dev* 29(2):247–256. Springer Verlag (Germany), 2009. <http://link.springer.com/article/10.1051%2Fagror%3A2008053>
- Weng F, Zhang W, Wu X, Xu X, Ding Y, Li G, Liu Z, Wang S (2017) Impact of low-temperature, overcast and rainy weather during the reproductive growth stage on lodging resistance of rice. *Sci Rep* 7:1–9
- World Bank (2013) Turn down the heat: climate extremes, regional impacts, and the case for resilience. A report for the World Bank by the Potsdam Institute for Climate Impact Research and Climate Analytics. World Bank, Washington, DC. License: Creative Commons Attribution – Non Commercial–NoDerivatives3.0 Unported license (CC BY-NC-ND 3.0). [http://www.worldbank.org/content/dam/Worldbank/document/Full\\_Report\\_Vol\\_2\\_Turn\\_Down\\_The\\_Heat\\_%20Climate\\_Extremes\\_Regional\\_Impacts\\_Case\\_for\\_Resilience\\_Print%20version\\_FINAL.pdf](http://www.worldbank.org/content/dam/Worldbank/document/Full_Report_Vol_2_Turn_Down_The_Heat_%20Climate_Extremes_Regional_Impacts_Case_for_Resilience_Print%20version_FINAL.pdf)
- Yaro JW (2013) The perception of and adaptation to climate variability/change in Ghana by small-scale and commercial farmers. *Reg Environ Chang* 13(6):1259–1272
- Zivanomoyo J, Mukarati J (2012) Determinants of choice of crop variety as climate change adaptation option in arid regions of Zimbabwe. *Russ J Agric Socio-Econ Sci* 3(15). [http://www.rjoas.com/issue-2013-03/i015\\_article\\_2013\\_08.pdf](http://www.rjoas.com/issue-2013-03/i015_article_2013_08.pdf)

**Open Access** This chapter is licensed under the terms of the Creative Commons Attribution 4.0 International License (<http://creativecommons.org/licenses/by/4.0/>), which permits use, sharing, adaptation, distribution and reproduction in any medium or format, as long as you give appropriate credit to the original author(s) and the source, provide a link to the Creative Commons license and indicate if changes were made.

The images or other third party material in this chapter are included in the chapter's Creative Commons license, unless indicated otherwise in a credit line to the material. If material is not included in the chapter's Creative Commons license and your intended use is not permitted by statutory regulation or exceeds the permitted use, you will need to obtain permission directly from the copyright holder.





# Assessment of Farmers' Indigenous Technology Adoptions for Climate Change Adaptation in Nigeria

# 6

Idowu Ologeh, Francis Adesina, and Victor Sobanke

## Contents

Introduction .....	118
Issue Description .....	120
Research Techniques and Findings .....	120
Devastating Effects of Climate Change on Smallholder Farmers .....	122
Indigenous Adaptation Techniques in Use in Nigeria .....	122
Constraints to the Development of Indigenous Adaptation Techniques in Nigeria .....	125
Indigenous Adaptation Techniques Contributing Factors .....	126
Conclusion .....	128
References .....	128

## Abstract

Agriculture has shown a considerable capacity to adapt to climate change. Many adaptations occur autonomously without the need for conscious response by farmers and agricultural planners. However, it is likely that the rate and magnitude of climate change may exceed that of normal change in agriculture that specific technologies and management styles may need to be adopted to avoid the

---

This chapter was previously published non-open access with exclusive rights reserved by the Publisher. It has been changed retrospectively to open access under a CC BY 4.0 license and the copyright holder is "The Author(s)". For further details, please see the license information at the end of the chapter.

---

I. Ologeh (✉)

Department of Environmental Management and Toxicology, Lead City University, Ibadan, Nigeria  
e-mail: [Ologeh.idowu@lcu.edu.ng](mailto:Ologeh.idowu@lcu.edu.ng)

F. Adesina

Department of Geography, Obafemi Awolowo University, Ile-Ife, Nigeria

V. Sobanke

Research and Planning Department, National Centre for Technology Management, South West Office, Lagos, Nigeria

© The Author(s) 2021

W. Leal Filho et al. (eds.), *African Handbook of Climate Change Adaptation*,  
[https://doi.org/10.1007/978-3-030-45106-6\\_28](https://doi.org/10.1007/978-3-030-45106-6_28)

117



most serious of effects. Thus areas likely to be most vulnerable to climate variability can be spared from its impacts through implementation of appropriate adaptation measures such as development of indigenous technologies.

Six hundred farmers from the six geopolitical zones of Nigeria were surveyed and they all possess different indigenous adaptation strategies ranging from swamp farming (Oyo State), application of neem seed (Kaduna State), soil erosion control (Enugu State), rainwater harvesting (Taraba State), land improvement (Cross River State) to farmland management (Benue State). They all have simple but profound technologies driving these schemes with much success. These indigenous adaptation techniques are majorly constrained by inadequate financial resources. Indigenous technology adoption is affordable with high revenue potential.

---

**Keywords**

Indigenous technology · Climate change adaptation · Farmers · Nigeria

---

**Introduction**

Historically, agriculture has shown a considerable capacity to adapt to changing climatic conditions. If climate change is gradual, the adaptation may go widely unobserved and the adjustment process largely independent (Parry et al. 2004). In the field of climate change, vulnerability has been described as the degree to which a system is susceptible to, or unable to cope with, adverse effects of climate change, including climate variability and extremes (Marrewijk 2011). Thus the need for climate change adaptation/mitigation measures to combat vulnerability. The major task of climate change adaptation and mitigation in agriculture is to produce more food efficiently and with clear reductions in greenhouse gas (GHG) releases from food manufacturing and marketing. “Adaptation” can be defined as societal or ecosystems efforts to prepare for or cope with future climate change. The coping methods can be defensive (i.e., being protective against adverse impacts of climate change), or adaptable (i.e., seizing the benefits of any advantageous effects of climate change) (USEPA 2014).

Nigeria along with other developing countries under UNFCCC is to focus on adaptation to make them able to cope with the new extremes in climatic regimes; they are also to concentrate on environmentally and economically sustainable development (Adesina and Odekunle 2011a). The argument is, the developing countries’ growth is being impaired by climate change effect and these countries produce only a small fraction of the GHG that is causing climate change. They also have fragile adaptive capability because their economies are still growing, thus they are highly vulnerable to the impacts of climate change.

Climate change adaptation is not novel; history has told how human societies whether by migration, improved crop varieties, or diversifying housing types have repeatedly proven strong capacities for adapting to different climates and environmental changes (Adger et al. 2007). However, the current rate of global climate change is unusually high compared to past changes that society has experienced and

thus new innovations are necessary to combat the challenge. In this era that the world is getting increasingly interdependent, adverse effects of climate change on one community or economic sector can have aftermaths around the world (United States Global Change Research Programme – USGCRP 2009).

Adaptation is globally important because climate change will not become history soon. Many greenhouse gases linger in the atmosphere for 100 years or more after their emission and because of their long-lasting effects, they will continue to warm Earth in the twenty-first century, even if additional greenhouse gases emission were to stop today. Therefore, steps must be taken now to prepare for, and respond to, the impacts of climate change that are already occurring, and those that are projected to occur in the years ahead (USGCRP 2009).

There is need for continuous actions to mitigate climate because there are limits to the ability to adapt. Adaptation alone on long-term basis may not be sufficient to cope with all the projected impacts of climate change, thus it will need to be continuously coupled with actions to lower greenhouse gas emissions (IPCC 2007).

Adaptation is based on the level of socioeconomic development of a country; the resilience and adaptive capacity of a country is dependent on its level of development with respect to economy and political stability. To improve adaptation strategies, a clear understanding of local susceptibilities to climate change and critical thresholds must be established. Adaptation strategies should be adequately flexible in order to accommodate future possible changes in climatic parameters which may be responsible for quick review of plans; the plan should be reviewed periodically.

A myriad of possible adaptation strategies for agriculture are available; some of the most prominent in Nigeria are innovative indigenous technology options ranging from improved crop varieties, composting of organic waste, recycling and waste minimization, improved cultivation techniques, and cover cropping (Eze and Osahon 2015).

Reactive adaptations are those which occur after the impacts of climate change have been experienced, while anticipatory adaptations are proactive, undertaken before the impacts are fully felt. Planned adaptations are generally anticipatory, but can also be reactive (i.e., climate change effects are experienced). Farmers have access to various adaptations depending on their local environments and the specific farming system.

Some impact studies have suggested “adaptations” involving reductions and expansions of agricultural zones. This implies that some farmers would relocate, or others would completely change their type of farming while others would stop operations in some locations. Also, in other locations, there would be new farmers and some existing landowners would try new types of farming (Adesina and Odekunle 2011b). Although adaptations can be strategic at the farm level, the term “planned adaptation” is commonly used to describe actions taken by governments as a conscious policy response. Probable governments’ planned adaptations include reinforcement of technological adaptations, such as crop development and early warning systems, promotion of land and water use options, changes in diversification or intensity of production aid, transformed financial support in established programs, and impromptu compensation.

---

## Issue Description

Smallholder farmers were facing a lot of climate change-induced challenges on their farms of which flooding, pest and disease invasion, high temperature, and low crop yield are the most prominent. The Nigerian government has promoted various adaptation measures as its effort to curtail these challenges. These include provision of improved crop varieties, fertilizers, irrigation schemes, and geodata (Adefolalu 2007). Wisner et al. (2004) report that farmers' vulnerability is not determined by the nature and magnitude of climate change as such, but by the interplay of the societal capacity to adapt and/or recuperate from environmental change. The adaptation capacity and degree of exposure is connected to environmental changes and also to changes in societal aspects such as land use and cultural practices. Most studies on climate change and agriculture in Africa have concentrated on actual and projected impacts as well as farmers' coping/adaptation strategies (Adejuwon 2004). There has been little or no work in the area of local/indigenous adaptation technologies and their challenges or success. This chapter will therefore attempt, through a questionnaire survey, Focus Group Discussions, and review of relevant literature, to fill this gap.

The objective of this chapter is to assess indigenous technology adaptation options being used by smallholder farmers in Nigeria.

---

## Research Techniques and Findings

The survey area is Nigeria; for ease of data collection, the major food-producing state of each geopolitical zone in the country is sampled for the survey. After relevant literature and National Bureau of Statistics consultation, the following six states were selected for the survey:

North-Central Zone – Benue State  
North East Zone – Kaduna State  
North-West Zone – Taraba State  
South-East Zone – Enugu State  
South-South Zone – Cross River  
South-West Zone – Oyo State

It is very important to assess the various indigenous technology adaptations in use by smallholder farmers in Nigeria so as to know which can be fully developed for national adoption. To achieve this objective, 600 questionnaires were administered to smallholder farmers in the six states to survey their various indigenously designed adaptation options to climate change. The questionnaires were designed to collect information on farmers' biometric data, years of experience and skills, farm size, types of crops cultivated, educational level, experiences on climate change effects, and indigenous adaptation techniques. Secondary data was obtained from NBS and the Agricultural Development Agencies of each of the States. The retrieved

questionnaires were imputed and analyzed using Microsoft Excel spreadsheet 2016 and the results are presented in frequencies and percentages.

A total of six hundred questionnaires were administered to smallholder farmers in the six states, and all were retrieved through the assistance of agricultural extension workers who administered them, the results are presented in Table 1.

In order to obtain realistic data, matured farmers are targeted, the average age is 53 years old. Majority (86%) of the farmers have more than 30 years of experience in farming with 60% of them owning more than one hectares of land. Female farm owners (42%) are mostly found in Southern Nigeria while men majorly own farmland in the north, and employ numerous women laborers. The most grown crops across Nigeria as detected in the data are cassava, maize, yam, rice, and vegetables.

Almost all the farmers (97%) complained of the various losses they have incurred due to devastation effects of climate change ranging from drought encroachment in the north to flooding in the south. The totality of the respondent farmers have poor knowledge of the scientific explanations behind climate change, but experience taught them that nature (weather) is no longer their friend and they have to devise strategies to make it work in their favor. Their understanding is that nature (or the gods) is fighting them through the massive attack of pests and diseases, flooding, erratic rainfall, high temperature, and low yield. As a result, they devise different techniques to adapt to climate change effects including sacrificing to the gods. These indigenous adaptation techniques vary from zone to zone, depending on the

**Table 1** Socioeconomic characteristics of sampled smallholder farmers

Variables	Categories	Benue	Cross River	Enugu	Kaduna	Oyo	Taraba
		Freq/%	Freq/%	Freq/%	Freq/%	Freq/%	Freq/%
Sex	Male	67	41	46	72	52	66
	Female	33	59	54	28	48	34
Age(years)	≤ 40	2	3	0	1	0	4
	41–50	39	37	30	26	29	29
	51–60	54	51	59	58	61	59
	61–70	5	9	11	15	10	8
Marital Status	Single	3	2	4	0	7	0
Status	Married	97	96	91	99	89	98
	Widowed	0	2	5	1	4	2
Levels of Educational Attainment	Informal	61	14	17	48	12	68
	Primary	32	52	32	38	23	30
	Secondary	07	34	51	14	65	02
Farm Size(ha)	≤ 1	25	63	67	31	33	21
	2–5	57	26	29	42	55	56
	Above 5	18	11	4	27	12	23
Farming Experience (years)	≤ 30	13	19	18	11	17	6
	31–40	60	55	53	58	56	62
	Above 41	27	26	29	31	27	32

Source: Fieldwork

prevalent climate change effect in the area. Swamp farming was devised in Oyo State, discovery, and application of neem seed to enhance soil fertility in Kaduna State, improved soil erosion control in Enugu State, rainwater harvesting in Taraba State, intentional cover cropping in Cross River State to farmland management (organic manure) in Benue State. They all have simple but profound technologies driving these schemes which will be discussed in details.

This finding harmonized with that of Eze and Osahon (2015) who listed adaptation strategies as improved crop varieties, composting of organic waste, recycling, and waste minimization, improved cultivation techniques, and cover cropping.

## **Devastating Effects of Climate Change on Smallholder Farmers**

All the smallholder farmers surveyed have in their more than 30 years of experience suffered different adverse effects of climate change. The prominent effect in Northern Nigeria is erratic rainfall and unusual heat (heatwave). They are also faced with desert encroachment advancing into Nigeria from Niger republic and pest invasion. Their counterparts in the South are majorly faced with flooding, infertility, increase in temperature, and pest invasion. The major effect in North Central is the increase in temperature, soil infertility, and pest invasion.

The finding is in agreement with the work of Lybbert and Sumner (2010) that temperature increase is an indication of climate change, and also the work of Adegoke et al. (2014), who stated that weeds, pests, and fungi thrive under warmer temperatures, wetter climates, and increased carbon dioxide (CO<sub>2</sub>) levels.

The different climate change effects being experienced in different zones in Nigeria dictate the corresponding indigenous adaptation techniques, and these are presented in Tables 2 and 3.

## **Indigenous Adaptation Techniques in Use in Nigeria**

### **North-Central Zone – Benue State**

Benue State is the food basket of Nigeria, the state is popular for large-scale food and fruit production including yam, cassava, sweet potato, beans, maize, millet, guinea corn, vegetables, soybeans, rice, and citrus. The smallholder farmers in Benue State are faced with climate change impacts such as soil infertility, increase in temperature, pests and diseases invasion, crop failure, and increased weed. To mitigate/adapt to these effects, the adaptation strategies common to smallholder farmers in the state are mixed cropping, growing pest/disease-resistant crop varieties, use of cover crops, and making bigger ridges.

The prominent indigenous adaptation practice in the state is local farmland management. The Benue farmers devised a farmland management practice to adapt to climate change. The practice entails conscious efforts to reduce temperature on farmlands and is very similar to organic agriculture. It is a complete management system with high organic matter content (mulching), soil cover (cover crops/tree

**Table 2** Devastating effects of climate change on smallholder farmers

Variables	Benue	Cross river	Enugu	Kaduna	Oyo	Taraba
	Mean (M)	Mean (M)	Mean (M)	Mean (M)	Mean (M)	Mean (M)
Mean max 5						
Soil infertility	4.2	2.1	1.9	4.4	2.7	3.0
Increase in temperature	4.3	4.0	4.3	4.2	4.4	4.1
Pest invasion	4.6	4.7	4.5	4.4	4.5	4.4
Crop failure	3.6	4.2	3.9	4.0	3.5	3.7
Increased weed	3.9	3.8	3.1	2.8	3.4	4.2
Drought	1.2	0.8	1.5	3.8	1.1	3.7
Land degradation	2.3	2.8	2.5	3.6	3.1	3.2
Flooding	3.2	3.8	4.1	3.6	3.9	2.9
Access to water	2.4	0.5	1.5	3.7	1.2	3.4
Decrease in soil moisture	3.1	1.5	2.4	3.2	2.1	3.7
Erosion	3.4	3.2	3.9	3.1	3.8	2.9

Source: Fieldwork

planting), and high soil fertility (crop rotation, organic manures, and legume planting) thus retaining nutrient and water, building more floods, drought, and land degradation resilient soils.

### North West Zone – Kaduna State

Kaduna is a state in which 80% of the people are actively engaged in farming. They produce crops ranging from yam, maize, beans, guinea corn, millet, rice, and cassava. The prevalent climate change impacts in the state are drought, pests and diseases invasion, crop failure, land degradation, increase in temperature, flooding, access to water and soil infertility. The widely adopted adaptation practices are mixed farming, mixed cropping, growing drought-resistant crop varieties, growing pest-resistant crop varieties, crop rotation, irrigation, roof water harvesting, and making bigger ridges.

The unique indigenous adaptation method in use in the State is the application of neem seed for pest control (used as fumigant, pesticide), compost (used as fertilizer, manure), and soil fertility (used as soil conditioner and urea coating agent).

### North-East Zone – Taraba State

Taraba State just as his North-West counterpart is 80% agrarian. They produce crops ranging from maize, millet, sorghum, rice, yam, cassava, and sweet potatoes. They experience climate change effects such as high rate of weeds, drought, decrease in soil moisture, increase in temperature, decrease in crop yields, and high rate of pests and disease incidence. The adaptation measures generally in use in the State are growing drought-resistant crop varieties, crop rotation, irrigation, integration of livestock farming system, changing crop varieties, mulching, and intercropping.

**Table 3** General adaptation techniques in use in Nigeria

Variables	Benue	Cross river	Enugu	Kaduna	Oyo	Taraba
	Mean (M)	Mean (M)	Mean (M)	Mean (M)	Mean (M)	Mean (M)
Mean max 5						
Mixed cropping	3.7			3.8		
Growing pest/disease resistant crop varieties	3.9	3.7	3.7	4.1	4.4	3.4
Use of cover crops	3.6	3.7	2.9	3.3	3.4	3.1
Making bigger ridges	3.5	3.3	3.3	3.7	3.4	3.3
Mixed farming	3.2	2.7	2.8	4.4	3.1	3.4
Growing drought resistant crop varieties	3.1	2.1	2.8	3.6	2.8	3.5
Mulching	3.1	4.2	3.3	3.2	3.9	4.4
Crop rotation	3.4	2.1	2.4	3.7	2.7	4.1
Irrigation	3.4	3.3	3.4	4.0	4.2	4.1
Roof water harvesting	3.1	2.7	2.8	3.7	2.5	3.1
Integration of livestock farming system	2.3	1.2	1.8	3.3	2.9	3.6
Changing crop varieties	2.6	2.2	2.4	3.1	3.3	3.6
Intercropping	3.2	2.3	2.8	3.1	3.3	3.8
Use of pesticides/herbicides	2.4	2.5	3.9	2.7	4.2	3.1
Construction of drainage systems	1.2	3.7	4.2	2.2	2.9	2.8
Contour cropping	2.1	2.0	3.9	3.1	3.4	3.1
Diversification in crop planting	2.4	3.6	3.8	2.8	3.2	3.0
Ridge construction	2.8	2.7	3.3	3.4	3.3	3.5
Crop substitution	3.4	2.1	2.8	3.3	3.4	3.7
Changing planting dates	3.1	3.1	3.0	3.3	3.2	3.5

Source: Fieldwork

The indigenous adaptation practice unique to Taraba State is rain harvesting. Access to water is an issue in the state and thus the need for irrigation. Rain harvesting is used to augment the water used for irrigation. The most common is roof water harvesting which is channeled into catchment tanks or concrete reservoirs.

### South-East Zone – Enugu State

Enugu State has a diversified economy dominated by agriculture. Major crops produced in the State are yam, cassava, maize, rice, cowpea, sweet potatoes, and plantain. Their crop production is impaired by climate change effects such as increase in temperature, flood, soil erosion, pests and diseases invasion, and crop failure. Adaptation practices widely in use in the State include planting pest/disease-resistant crop varieties, use of pesticides/herbicides, construction of drainage systems, contour cropping, and diversification in crop planting.

Soil erosion is the major problem affecting smallholder farmers in Enugu State, and its volume was aggravated by the effects of climate change. Their key indigenous adaptation strategy is soil erosion control using stone and sandbags to divert

erosion away from the farms, ridging, and use of wrapped weeds or grasses to cover planted heaps. Stems from previous harvests are also arranged or scattered on the soil in bands to reduce soil erosion. Tree planting on the borders of the farm also prevents soil erosion as the trees shield the farm from direct impact of rainfall.

### **South-South Zone – Cross River**

Cross River State famously known for tourism and fishing is also fully involved in agriculture. The crops mainly cultivated in the State are cassava, yam, plantain, rice, and maize. Although it is a coastal state, they also have their share of climate change effects. They are affected by increased weeds, pests and diseases invasion, increase in temperature, crop failure, and flooding. They adapt by planting pest-resistant crop varieties, diversification of crops, planting cover crops, mulching, and construction of drainage systems.

Indigenous land improvement methods are the key indigenous adaptation practice in Cross River State. These methods include organic addition to the land (mulching, compost, and manure), cover tree planting, planting of legume crops (mixed cropping), and polyculture. Water harvesting from runoffs also helps to maintain soil moisture during dry season.

### **South-West Zone – Oyo State**

Oyo State is an industrialized state with many educational institutions. It also enjoys diversified economy with agriculture as the major occupation. Smallholder farmers in Oyo State are faced with climate change effects like their counterparts in other states, this includes flooding, pests and diseases invasion, soil erosion, crop failure, and increased temperature. Their general adaptation methods are ridge construction, use of pesticides and pest-resistant crop variety, irrigation, crop substitution, and changing planting dates.

The major captivating indigenous adaptation method practiced by the smallholder farmers in Oyo State is swamp farming. There are lots of swamp areas in Oyo State, where smallholders resort to when there is prolonged delay in rainfall season. This initiative allows early and late farming as there is constant access to water. Some farmers in Oke Ogun area of the state channel their domestic wastewater to wet their vegetable farms all year round.

These findings are in agreement with that of Adger et al. (2007) that listed adaptation strategies as migration, improved crop varieties, or building different types of shelter, while Anríquez and Stamoulis (2007) list include changing the timing of operations, adoption of conservation tillage practices, and diversification in production systems, improvement of irrigation schemes, modification of farm support programs, and development of new plant varieties.

## **Constraints to the Development of Indigenous Adaptation Techniques in Nigeria**

The various indigenous adaptation strategies assessed have developmental constraints. The major is inadequate financial resources; adaptation practices are cost-



intensive and these smallholder farmers cannot afford elaborate adaptation strategies. Even the indigenous methods need funding to develop, e.g., the planting and processing of neem seed in Kaduna State and soil erosion control in Enugu State. Other constraints include inadequate farm labor due to express increase in rural-urban migration; poor extension services, insufficient drought-resistant varieties, and strict adherence to local varieties (see Table 4).

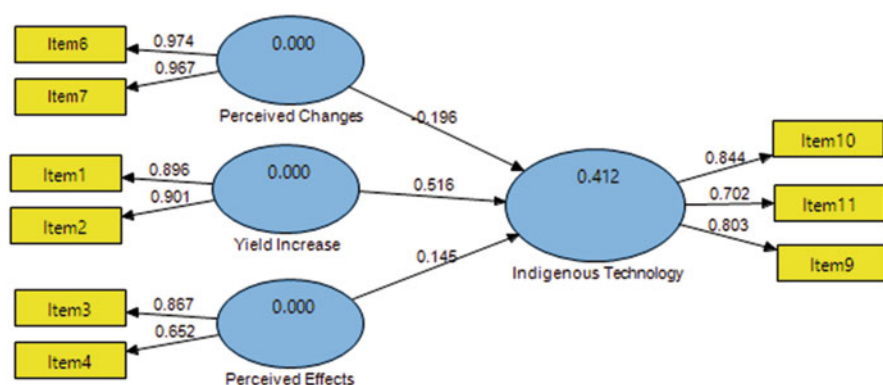
## Indigenous Adaptation Techniques Contributing Factors

The results of the partial least squares (Ringle et al. 2005) are presented in Fig. 1, and showed the factor loadings for all observed variables,  $R^2$  value of the unobserved endogenous (dependent) variable as well as regression coefficients between exogenous and endogenous unobserved variables. Nine (9) observed variables

**Table 4** Constraints to the development of indigenous adaptation techniques in Nigeria

Variables	Benue	Cross river	Enugu	Kaduna	Oyo	Taraba
	Freq /%	Freq /%	Freq /%	Freq /%	Freq /%	Freq /%
Finance	93	92	88	95	91	86
Farm labor	34	62	57	37	48	33
Poor extension services	23	42	38	31	54	48
Insufficient drought-resistant varieties	76	84	63	67	66	52
Strict adherence to local varieties	62	33	28	56	14	51

Source: Fieldwork



**Fig. 1** Structural model of indigenous technology adoption

with high loadings were retained for further analysis, while items with low factor loadings were removed. The  $R^2$  value of 0.412 indicates that about 41% variance observed in the choice of indigenous adaptation techniques employed by farmers can be explained by farmers' perceived effect of climate change, need for crop yield increase, and perception of changing weather.

Reliability and validity of unobserved variables is presented in Table 5. The results show that composite reliability (CR) which indicates the convergent validity in all the constructs is adequate and above 0.7 the minimum threshold (Hair et al. 2010). The average variance extracted (AVE) which is a more conservative method of measuring convergent validity than CR (Malhotra and Dash 2011) is also within the recommended threshold ( $>0.5$ ). On the contrary, only the value of Cronbach's alpha for perceived effects was below the recommended threshold (0.7).

The results of the T-statistics showing the significant level of regression coefficients are presented in Table 6. This result showed that indigenous adaptation techniques by respondents is influenced by their perceived changes (2.703;  $p < 0.05$ ) and yield increase (6.665;  $p < 0.05$ ). The result suggest that respondent's choice of indigenous adaptation techniques depends on the aspect of perceived changes in climatic parameters as well as the usefulness of climatic information.

**Table 5** Reliability and validity of unobserved variables

	AVE	Composite reliability	Cronbach's alpha	Communality	Redundancy
Indigenous technology	0.617	0.828	0.700	0.617	0.056
Perceived changes	0.942	0.970	0.938	0.942	
Perceived effects	0.589	0.737	0.317	0.589	
Yield increase	0.807	0.893	0.761	0.807	

**Table 6** Path analysis

	Original sample (O)	Sample mean (M)	Standard deviation (STDEV)	Standard error (STERR)	T-statistics ( O/STERR )
Perceived changes - > indigenous technology	-0.196	-0.198	0.072	0.072	2.703
Perceived effects - > indigenous technology	0.145	0.156	0.081	0.081	1.782
Yield increase - > indigenous technology	0.516	0.519	0.077	0.077	6.665

## Conclusion

The chapter examined the various climate change effects affecting smallholder farmers across Nigeria. The general adaptation techniques adopted in each geopolitical zone of the nation were assessed as well as peculiar indigenous adaptation techniques initiated and in use in each zone. The constraints to the development of the indigenous adaptation techniques were also investigated. Going forward, these indigenous techniques need to be developed and commercialized; the state and federal government agricultural schemes and agencies can fund this project and support the efforts of the smallholder farmers. It is also essential for a functional link to be established between the farmers' indigenous innovation and the academia to foster research and development.

---

## References

- Adefolalu DO (2007) Climate change and economic sustainability in Nigeria. In: Paper presented at the international conference on climate change and economic sustainability held at Nnamdi Azikiwe University, Awka, Nigeria. 12–14 June 2007
- Adegoke J, Araba A, Ibe C (2014) National agricultural resilience framework. Federal ministry of agriculture and rural development, Abuja
- Adejuwon SA (2004) Impacts of climate variability and climate change on crop yield in Nigeria. In: Paper presented at the stakeholder's workshop on assessment of impacts and adaptation to climate change, conference centre, Obafemi Awolowo University, Ile-Ife 20–21 September 2004
- Adesina FA, Odekunle TO (2011a) Climate change and adaptation in Nigeria: some background to Nigeria's response – part I. 2011. International conference on environmental and agriculture engineering IPCBEE vol.15 (2011). IACSIT Press, Singapore
- Adesina FA, Odekunle TO (2011b) Climate change and adaptation in Nigeria: some background to Nigeria's response – part III. 2011. International conference on environmental and agriculture engineering IPCBEE vol.15 (2011). IACSIT Press, Singapore
- Adger WN, Agrawala S, Mirza MMQ, Conde C, O'Brien K, Pulhin J, Pulwarty R, Smit B, Takahashi K (2007) Assessment of adaptation practices, options, constraints and capacity in climate change 2007: impacts, adaptation, and vulnerability. Contribution of working group II to the fourth assessment report of the intergovernmental panel on climate change. Eze and Osahon; AJAEES 6(1):45–55, 2015; Article no.AJAEES.2015.061 Asian Journal of Agricultural Extension, Economics & Sociology 6(1):45–55, 2015; Article no.AJAEES.2015.061 ISSN: 2320–7027
- Anríquez G, Stamoulis S (2007) Rural development and poverty reduction: is agriculture still the key? Journal of Agricultural and Development Economics 4(1):5–46
- Eze S and Osahon E (2015) Indigenous mitigation and adaptation to climate change among small holder farmers in arochukwu area of Abia State, Nigeria. Asian Journal of Agricultural Extension, Economics & Sociology 6(1): 45–55. Article no. AJAEES.2015.061 ISSN: 2320–7027
- Feenstra JF, Burton I, Smith JB, Tol RS (eds.) (1998) Handbook on Methods for Climate Change Impact Assessment and Adaptation Strategies. United Nations Environment Programme; Vrije Universiteit, Amsterdam. 8–1 – 8–39
- Hair JF, Black WC, Babin BJ, Anderson RE (2010) Multivariate data analysis: international version. Pearson, New Jersey

- Intergovernmental Panel on Climate Change- IPCC (2007) Summary for policymakers, in climate change 2007: impacts, adaptation and vulnerability. Contribution of working group II to the fourth assessment report of the intergovernmental panel on climate change. Cambridge University Press, Cambridge, UK, p 17
- Lybbert T, Sumner D (2010) Agricultural technologies for climate change mitigation and adaptation in developing countries: policy options for innovation and technology diffusion. International Centre for Trade and Sustainable Development (ICTSD), Geneva
- Malhotra NK, Dash S (2011) Marketing research an applied orientation. Pearson Publishing, London
- Marrewijk L (2011) Climate smart agriculture in the Mutale Basin, South Africa. *Sustain Livelihoods Biodivers Dev Countries* 4(2):5–6
- Parry ML, Rosenzweig Cynthia, Iglesias Ana, Livermore M, Fischer Günther (2004) Effects of climate change on global food production under SRES emission and socio-economic scenarios. *Global Environmental Change* 14:53–67. <https://doi.org/10.1016/j.gloenvcha.2003.10.008>
- Ringle CM, Wende S, Will A (2005) SmartPLS 2.0.M3. SmartPLS, Hamburg, <https://www.smartpls.com/smartpls2>
- United States Environmental Protection Agency -USEPA (2014) Climate change impacts and adapting to change. Retrieved March 31, 2015, from <http://www.epa.gov/climatechange/impacts-adaptation/>
- United States Global Change Research Program -USGCRP (2009) Global climate change impacts in the United States. In: Karl TR, Melillo JM, Peterson TC (eds) United States global change research program. Cambridge University Press, New York
- Wisner B, Blaikie P, Cannon T, Davis I (2004) At risk: natural hazards; people's vulnerability and disasters. 2nd Edition. London: Routledge

**Open Access** This chapter is licensed under the terms of the Creative Commons Attribution 4.0 International License (<http://creativecommons.org/licenses/by/4.0/>), which permits use, sharing, adaptation, distribution and reproduction in any medium or format, as long as you give appropriate credit to the original author(s) and the source, provide a link to the Creative Commons license and indicate if changes were made.

The images or other third party material in this chapter are included in the chapter's Creative Commons license, unless indicated otherwise in a credit line to the material. If material is not included in the chapter's Creative Commons license and your intended use is not permitted by statutory regulation or exceeds the permitted use, you will need to obtain permission directly from the copyright holder.





# Case for Climate Smart Agriculture in Addressing the Threat of Climate Change

# 7

John Saviour Yaw Eleblu, Eugene Tenkorang Darko, and Eric Yirenkyi Danquah

## Contents

Introduction .....	132
Background .....	132
Climate Change and Food Security .....	133
Climate Smart Agriculture Technologies .....	135
Breeding and Climate Change .....	135
Efficient Resource Management .....	137
Integrated Renewable Energy Technologies of Farming Systems .....	139
Resource Conserving Technologies (RCTs) .....	140
Land Use Management .....	140
Cropping Season Variation .....	140
Crop Relocation .....	141
Efficient Pest Management .....	142
GIS Mapping .....	142
Conclusion .....	143
References .....	143

## Abstract

Climate smart agriculture (CSA) embodies a blend of innovations, practices, systems, and investment programmes that are used to mitigate against the adverse effects of climate change and variability on agriculture for sustained food

This chapter was previously published non-open access with exclusive rights reserved by the Publisher. It has been changed retrospectively to open access under a CC BY 4.0 license and the copyright holder is “The Author(s)”. For further details, please see the license information at the end of the chapter.

J. S. Y. Eleblu (✉) · E. Y. Danquah

West Africa Centre for Crop Improvement, University of Ghana, College of Basic and Applied Sciences, Accra, Ghana

E. T. Darko

Geography and Resource Development, University of Ghana, Legon, Ghana

© The Author(s) 2021

W. Leal Filho et al. (eds.), *African Handbook of Climate Change Adaptation*,  
[https://doi.org/10.1007/978-3-030-45106-6\\_32](https://doi.org/10.1007/978-3-030-45106-6_32)

131

production. Food crop production under various climate change scenarios requires the use of improved technologies that are called climate smart agriculture to ensure increased productivity under adverse conditions of increased global temperatures, frequent and more intense storms, floods and drought stresses. This chapter summarizes available information on climate change and climate smart agriculture technologies. It is important to evaluate each climate change scenario and provide technologies that farmers, research scientists, and policy drivers can use to create the desired climate smart agriculture given the array of tools and resources available.

---

**Keywords**

Climate change · Climate · Climate smart agriculture · Food security · Breeding approaches

---

## Introduction

### Background

Climate describes the weather conditions of a region such as its temperature (hot, warm, or cold) which is due to amounts or intensity of sunshine, rainfall (dry or wetness) and its pattern, air pressure, humidity, cloudiness, and wind, throughout the year, averaged over a series of years. “Climate change” as a terminology was suggested by the World Meteorological Organization (WMO) in 1966 to represent climate variations over long periods of time often from decades to millennia, irrespective of the causative agents (Hulme 2017). The term has been widely accepted and has fast become a household name for climatic variations which are often not favorable for man’s survival. Climate change has largely been associated with anthropogenic global warming; however, it is indeed larger and encompasses all vagaries in climatic conditions which occur over decades. Also human activities are estimated to have caused approximately 1.0 °C of global warming above pre-industrial levels, with a likely range of 0.8 °C to 1.2 °C. Global warming is likely to reach 1.5 °C between 2030 and 2052 if it continues to increase at the current rate (IPCC 2018). In today’s world, the term climate change has evolved from being a technical jargon for describing vagaries in climatic pattern into a global issue agent which requires the intervention of man to prevent future disastrous outcomes being predicted.

It should be noted that this book chapter will cover very limited information on climate change as the objective is to guide the reader to appreciate the need for a response that adopts innovations to accelerate the development of climate smart agriculture technologies as mitigation efforts against climate change. With that understanding we shall proceed to attempt to cover the breadth of knowledge in a summary of what is known with regards to the expected impact of climate change on crop production and food security, an overview of climate smart agriculture technologies and what is possible given current trends in technology and innovation.

Even though mitigation and adaptation responses compete with each other due to potential negative trade-offs across spatial, temporal, institution (Smith and Olesen

2010), economic scales (Wilbanks and Sathaye 2007). While mitigation measures aim to reduce emissions on a global scale, adaptive measures are specific to micro-environments and address various local impacts of climate change. As a result of the interconnection between the environment and socio-economic risks, the agriculture sector offers opportunities for complementary actions through the implementation of ecosystem sensitive approaches known as the CSA. This new approach is to bridge the growing divide between the two discourses and foster long-term resilient development in the agriculture sector. CSA is defined by FAO as “agriculture that sustainably increases productivity, resilience (adaptation), reduces/removes GHG’s (mitigation) and enhances achievement of national food security and development goals’ (FAO 2010). Therefore, adaptation, mitigation, and food security are the three key pillars of CSA (Lipper et al. 2014).

Climate smart agriculture (CSA) is a way to achieve sustainable development as well as green economy goals. It intends towards food availability and takes part to conserve natural assets and is closely associated with perception of improved growth, as FAO develops it for crop yield (FAO 2011). There is a high need for climate smart agriculture because agricultural production systems are expected to produce food for a global population of about 9.1 billion people in 2050 and over 10 billion by the end of the century (UNFPA 2011). This, however, has necessitated the development of CSA strategies and policies at different levels of governance (Zougmore et al. 2016). Therefore, it is highly imperative to sustain livelihoods which are predominantly agrarian in these regions.

---

## Climate Change and Food Security

Climate change has the potential to threaten food production and, consequently, food security especially in vulnerable regions. One major area where the impact of climate change is expected to be very significant in threatening the very existence of humanity is the estimated effect of climate change on agriculture. Agriculture is the major source of income and livelihood for an estimated 70% of the poor and vulnerable people who live in rural areas with limited resources oftentimes without access to basic technologies (World Bank 2016b). However, the production of food is being affected by climate change, it is therefore important to study the influence of this global climate change to meet the requirements of people and is estimated that by 2100, the world population will reach about 10 billion (Boogaard et al. 2014). The climate change and variability will adversely impact on food security and agriculture livelihoods of the poorest farmers, fisher folks and forest dwellers. Even though sub Saharan Africa contributes less than 5% of the global greenhouse gas (GHG) emissions, the region is vulnerable to the negative effects of climate change due to the fact that the region’s development prospects are closely linked to the climate due to the great reliance on rainfall (Tol 2018). Added to other non-climatic stresses (poverty, inequality, and market shocks), the impact of climate change will make negatively impede the achievement of the Sustainable Development Goals (SDGs) on livelihoods, food security, poverty reduction, health, and access to clean water in vulnerable communities (IPCC 2014a). However, the use of

climate change predictions based on theories and past data accrued over centuries is difficult to use in projecting the expected impact of changing climates on food security. Since the institution of climate change as a body or a field of study, many academic and scientific publications have emerged. The first scientific work by Katz, published in the first issue of the first journal on climate change titled “Climate Change” on the effect of climate change on food production clearly questioned the accuracy of any such predictions and warned that the predicted impacts at the time were estimates should be acknowledged as such. A direct quote from Katz follows: *“Attempts to assess the impact of a hypothetical climatic change on food production have relied on the use of statistical models which predict crop yields using various climatic variables. It is emphasized that the coefficients of these models are not universal constants, but rather statistical estimates subject to several sources of error. Thus, any statement regarding the estimated impact of climatic change on food production must be qualified appropriately”* (Katz 1977).

The aforementioned challenges have been addressed by leading investigators recently where climate change impact has been modelled based on quick country-level measurement of vulnerability to food insecurity under a range of climate change and adaptation investment scenarios (Richardson et al. 2018). The findings have been made accessible through their publication and an online interactive portal that is user friendly for policymakers (Met Office 2015). The interactive graphically displayed model predicts that food insecurity vulnerability is anticipated to worsen rapidly under all simulations of GHG emissions, and the re-distribution of vulnerable geographic regions remains very similar to present-day conditions where sub-Saharan Africa and South Asia remain the most severely affected. By the year 2050, an additional 2.4 billion people expected to be living in developing countries with much concentration in South Asia and sub-Saharan African, where agriculture is an important sector and major employment source, but currently more than 20% of the population is on average food insecure (Wheeler and von Braun 2013). About 75% of the global poor live in rural areas, and agriculture is their most important source of income (International Fund for Agricultural Development 2011). High levels of adaptation is seen to be able to decrease vulnerability across affected areas; however, the only scenario with the highest level of mitigation combined with high levels of adaptation shows appreciable levels of reduction in vulnerability compared to the present-day prevailing conditions (Smith and Olesen 2010). As agriculture is directly affected by climate change, adaptation strategies are becoming increasingly important issues for promoting development (Clements et al. 2011). Therefore, adaptation strategies in the context of climate change are all those practices that are employed by smallholder farmers to either get used to or minimize the effects of climate change and variability. According to the IPCC, adaptation is the process of adjustment to actual or expected climate and its effects that in human systems, adaptation seeks to moderate or avoid harm or exploit beneficial opportunities (IPCC 2014). The strategies for adapting to climate change and variability can be grouped into two; namely, autonomous and planned adaptation strategies. The autonomous adaptation strategies involve actions taken by non-state agencies such as farmers, communities, or organizations and/or firms in response to climatic



shocks while planned adaptation involves actions taken by local, regional, and or national government to provide infrastructure and institutions to reduce the negative impact of climate change. However, the planned adaptation which measures or results from deliberate policy decisions and awareness from farm to global levels and are discussed in literature as key to reducing present and future vulnerability and climate impacts on livelihoods (IPCC 2014). However, there are limitations to planned adaptation measures under severe conditions. As a result, more systematic changes in adaptive capacity and resource allocation are being considered. So in this discussion we shall look at the various climate smart agriculture practices that can help mitigate the climate change effects on agriculture. Therefore, the effects of climate change can be solved by climate smart agriculture practices such as climate smart crop (breeding), improved pasture and animal rearing, amelioration of degraded lands, rehabilitation of polluted water bodies, and management of sustainable systems such as agroforestry, livestock management, and manure management. Also, the promotion of sustainable land management practices which are also part of CSA practices (Branca et al. 2011) have influenced paradigms shift from the traditional practices. Most of these technologies can help mitigate greenhouse gasses (GHG) emissions. Food security and improving food productivity can also reduce human vulnerability to climate impacts and the need for additional land conversion to agriculture, which represents almost as much as GHG emissions and those directly generated from agriculture activities (IPCC 2014), but food production and security measures may conflict with climate smart and conservation objectives, especially intensifying agriculture and producing more food for a growing population (Matocha et al. 2012).

---

## Climate Smart Agriculture Technologies

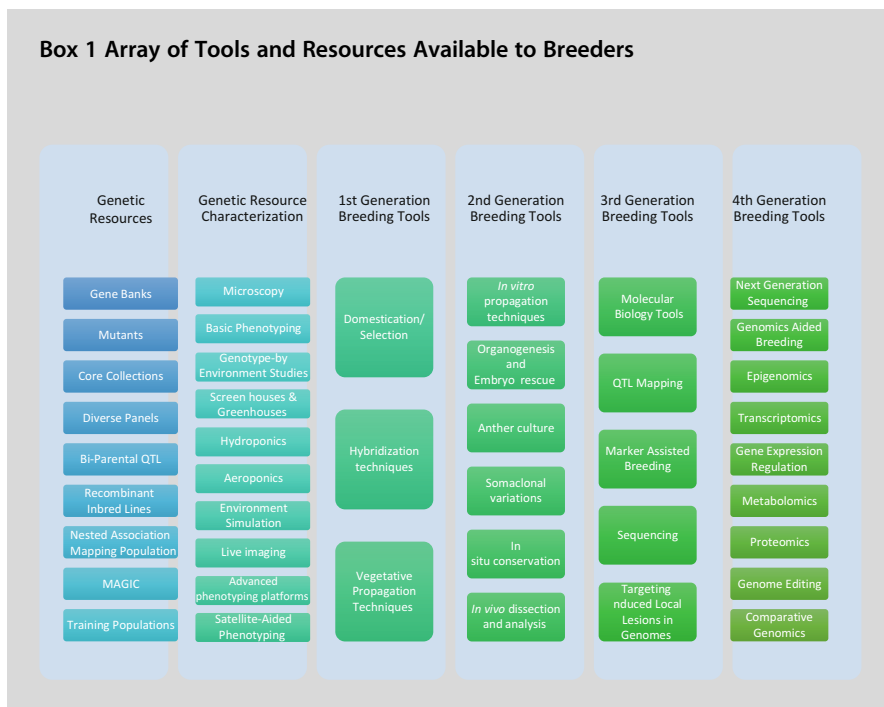
The climate smart agriculture technologies will focus on describing some of the approaches which include breeding (climate smart crop), efficient resource management, integrated renewable energy technologies for farming systems, resource conserving technologies, land use management, cropping season variation, efficient pest management, forecasting, and geographic information system (GIS) mapping.

### Breeding and Climate Change

Agriculture was born about 13,000 years ago when man gradually transitioned from hunting and gathering lifestyle into domestication of wild plants and animals. Food production systems since the invention of Agriculture which remains heavily dependent on the availability of rainfall has been evolving progressively to match-up to the growing demands of the human population. It is noteworthy that the art of breeding which emerged through domestication which involved selecting plants and animals that were acceptable with good qualities for the consumption/utilization by man. Breeding which begun as selection has seen many advancements; notable are

hybridization techniques, matting designs and schemes, genetics enhanced hybridization programs, tissue culture and mutagenesis aided systems, genetic engineering using recombinant DNA technologies, and Genomics- and other Omics-assisted breeding and the latest being genome editing. A summary of the resources and tools available for breeders in this day and age is presented in Box 1 below. As breeding has evolved based on man's knowledge and the development of tools to aid the development of new variants, climate and the rate of climate change has rapidly outpaced and outstripped the worlds production systems especially in areas of greatest vulnerability where new technologies remain inaccessible. The dry areas and flood prone areas are of the greatest concern where extreme weather conditions can prevail and persist for long periods disrupting the natural seasons and cycles of production that farmers are used to. These concerns can mostly be addressed if all tools available to breeders are widely accepted and utilized to aid in the development of climate smart crops that are designed to adapt to harsh and extreme weather conditions producing higher yields compared to currently available varieties that do poorly under such conditions.

**Box 1 Array of Tools and Resources Available to Breeders**



The myriad of available resources range from genetic resources available that are conserved in situ, ex situ, or in vitro; gene banks, core and representative collections not forgetting diverse panels in national, international, and regional research Centres as well as the Bi-parental, Recombinant Inbred Lines (RILs), Nested Association

Mapping, Multi-parent Advanced Generation Inter-cross (MAGIC) & Training populations in the hands of researchers and Scientists who originated and curated them. These genetic resources are sources of alleles of great agronomic importance required in the development of climate smart crops or animal breeds that can withstand and yield highly under changing climatic conditions. These are therefore the first range of arsenals of breeders in the fight against dwindling productivity under climate change conditions. The next in the array of tools are those that can be used to characterize, evaluate, detect, select, and then release these climate adaptable varieties to farmers and businesses for increasing productivity under prevailing circumstances. These tools have evolved from first generation to the current cutting edge fourth generation tools that are available for breeders to use in the development of new and improved varieties with better adaptation to the changing environmental conditions. The first-generation tools mainly encompass discoveries of basic principles of domestication/selection, the knowledge and use of pollination to make self and crosses as well as means of vegetative propagation such as grafting, corms, bulbs etc. Second generation array of tools are mainly based on advances in biology that allow for cell, tissue and organ culture which allow for more advanced technologies in the crop and animal improvement by breeders. Third and fourth generation tools such as represented in Box 1 that have been developed add speed and precision to the array of tools that are currently available for quick development of improved climate smart crops.

It is important to evaluate each climate change scenario and provide strategies breeders can use to create the desired climate smart crops given the array of tools and resources available. The various climate change scenarios, potential impact and climate smart breeding approaches are delineated in Table 1. For instance, climate change is greatly impacting agriculture currently in the tropics and other arid areas with erratic rainfalls that no longer follow the patterns or established seasons known to farmers that heavily depend on rain-fed crop production systems. This scenario has the potential impact of poor yields as a consequence of untimely start of the farming activities and crop failure. For adaptability to such scenarios, climate smart crops with adaptability to different types of droughts or erratic rains could be developed using a combination of tools and resources described in Box 1 and made available to farmers. Such climate smart crops are required in vulnerable areas threatened by climate change in order to avert the worsening food insecurity problem and ensure the achievement of sustainable development goals 1 (no poverty) and 2 (no hunger).

## **Efficient Resource Management**

Another approach that can be of relevance in achieving the objectives of climate smart agriculture is efficient management of resources. This approach is an important part of CSA and the future environment. In the food production chain, from the farmer to the customer or final consumer, almost one third part of the food is lost due

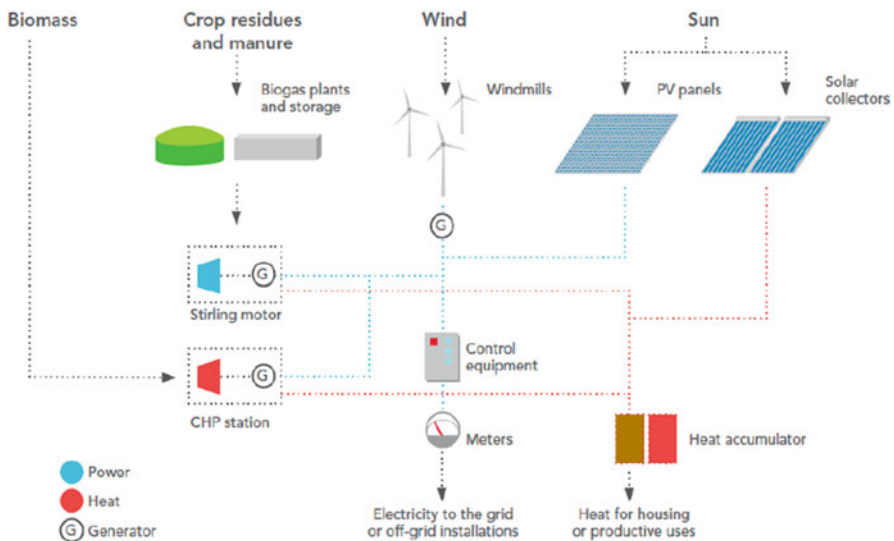
**Table 1** Climate change scenarios, potential impact, and climate smart breeding approaches

Climate change scenarios	Potential impact	Climate smart approaches
Erratic rainfall	Farmers plant too late or too early leading to yield losses	Climate smart crops with adaptability to different types of droughts or erratic rains.
Prolonged droughts in arid areas and New Droughts prone areas	Crop losses, Famine and loss of lives	Drought resistant crops that perform well under water limited conditions
Increased floods	Damage to crops and animals; loss of lives and property, displacement of people	Development of water loving crops as well as crops resistant to lodging
Intense rain and wind storms	Damage to crops and animals	None
Rise in sea levels	Increase in salt stress on crops, loss of arable lands to toxic levels of salts, low or no yields	Salt resistant or tolerant crops
Loss of soil cover	Soil erosion, loss of soil fertility, loss of microbes in the soil	Planting of trees and plants that will rehabilitate the soils. Introduction of bioengineered microbes that encourage soil health.
Increased global temperatures	Reduced yields, new pests and disease emergence and damage to crops and animals	Improved heat adaptable crops

to the improper management of resources (Hartter et al. 2017). On yearly basis, for instance, the total energy consumption in the global food losses are almost 38% of all the energies utilized by the food chain. Critical areas in the food chain processes which serve as good avenues for improving energy efficiency includes: transportation, conservation, processing, cooking, and consumption (FAO 2011). In Africa, a majority of wood removed is used for manufacturing household articles as well as cooking. However, cooking in stoves helps save energy thereby decreasing deforestation in the long run. For instance, this technique of managing resources and climate change projects has helped in supporting sustainable intensification through a number of initiatives including the establishment of an agriculture information and the decision support system and the preparation of soil management plans. Since this approach was adopted in 2014, climate smart agriculture was adopted on 2,946,000 hectares and has provided for a carbon sequestration potential of up to 9 million tons carbon dioxide annually, (<https://www.worldbank.org/en/topic/climate-smart-agriculture>). Additionally pastoralists are also enjoying some benefits from climate smart agriculture in the Sahel, Burkina Faso, Chad, Mali, Mauritania, Senegal, and Niger. The application of rangeland management is boosting productivity and resilience. This approach is also helping to reduce emissions.

## Integrated Renewable Energy Technologies of Farming Systems

The Integrated Renewable Energy Technologies is the application of suitable energy technologies, tools, and different farming services which are relevant in creating the stable change to energy smart proficient food systems. These technologies are governed by conditions of nature. These technologies are very useful because in the long run there will be a reduction in GHG's emissions. For instance, mid-season aeration can be promoted through short term drainage. Some of the technologies in the energy smart food system are the windmills, solar panels, wind generators, photovoltaic lights, biogas, and conversion of hydrothermal tools, bio energy and water pumping machines, information and communication technological innovation, and other similar approaches (Bochtis et al. 2014; Basche 2015). This technology has been applied in Morocco through the Morocco inclusive project Green Growth project, through the supply of agrometeorological information and the facilitation of the resilience building technology such as direct seeders. The pumps used can be both fuel and electric water pumps which are mostly used on irrigation farming (deep well and submersible pumps). Stakeholders in the agricultural industry should appreciate this modern technological innovation due to the benefits of increasing the value of production in the farming business. Most times, these technologies are linked on the farm from an integrated food energy system as shown in Fig. 1 below.



**Fig. 1** Integrated renewable energy technologies for farming systems. (Source: Amin et al. 2016)

## Resource Conserving Technologies (RCTs)

This technology consists of methods that enhance efficiency in the management of inputs. When these resource technologies are implemented, it comes with its own merits which includes low cost of productivity, limited use of fuel, labor, water, and early planting of crops which results in improved yields in the long run. For instance, the zero tillage system, which happens to be one of the resource conserving technologies, is a type of cultivation system in which the seeds are directly sowed into a virgin (uncultivated) soil. The zero-tillage system, however, involves the cultivation of crops into untilled soil by aeration of thin channels with adequate depth-width so as to attain suitable seed coverage. The soil remaining is left as if tillage has never been done on it before (Derpsch et al. 2010). In some parts of the globe, the zero tillage permits farmers to grow wheat very soon after the rice harvest. This allows the head of the crops to appear and the filling of the grains before the warm weather, pre-monsoon set off. Therefore, as the average temperature of the globe in certain parts rises, early planting will be more relevant for the production of wheat (Pathak 2009).

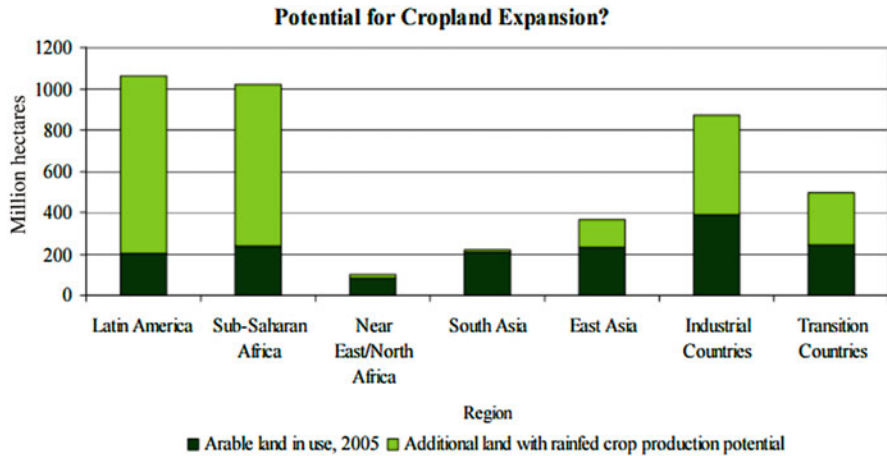
## Land Use Management

Land use management involves the proper planning of land and its usage. The proper planning includes fixing the location of plants and livestock production, changing the concentration of the application of plant foods and bug sprays can reduce global warming on agricultural activities (Ahmad et al. 2014). Other land use practices involve shifting production out of marginal areas, changing the role of applying cartilage and pesticides. However, it must be noted that capital and labor can minimize the risks from Climate change on agriculture production. The farmers can regulate the duration of the growing season by changing the time at which the farming fields are sown. Other adaptation mechanisms can be in the form of changing the times of irrigation and use of fertilizer.

Figure 2 elucidates Cropland Expansion Potential for different continents.

## Cropping Season Variation

The planting dates can be set to reduce the infertility that is caused by increasing temperatures; this may prevent the flowering period from meeting with the hot period (Arslan et al. 2015). The effects of the increased climatic variations which normally happens in both the semiarid and arid regions sometimes take advantage of the wet period by changing the planting times/dates. However, this approach is usually to avoid intense weather events in the growing season. This system of cultivation promotes the development of strong cultivars thereby leading to the production of different crops. The planting dates can be set to reduce the infertility that is caused by increasing temperature; this may prevent the flowering period from



**Fig. 2** Land use management. (Source: Burnisma 2009)

meeting with the hot period. The effects of the increased climatic variations which normally happens in both the semiarid and arid regions sometimes take advantage of the wet period by changing the planting times/dates. However, this approach is usually to avoid intense weather events in the growing season. This system of cultivation promotes the development of strong cultivars thereby leading to the production of different crops. The farmers will, therefore, need to ensure that they adopt the changing crop rotation system in the various hydrological cycles (Pathak et al. 2012).

## Crop Relocation

This approach involves the grouping and sorting of the plants and the varieties with respect to its sensitivity to the weather condition of a place. Crop relocation helps the crops to perform well according to the sensitivity of the climate during the vegetative and productive stages (Shames et al. 2012). There are several factors which affect agricultural production as a result of climatic change. These include increase in temperature, carbon dioxide (CO<sub>2</sub>) levels, and increase in drought and floods. These impacts vary across the various regions in the world as well as the different cultures. Other factors such as daylight, temperature, and humidity are very necessary for the vegetative and reproductive growth of the crops. Additionally the period for harvesting should be properly done so as to minimize losses during the period (Baba et al. 2017). However, it is therefore important to differentiate regions and crops that are highly susceptible to climate change. For instance, it is obvious that temperature increases affect the quality of many important crops. Some of these crops with respect to the discussion include basmati rice and tea.

## Efficient Pest Management

The normal agriculture pest and insect management on farms poses a threat to the environment. The usage of chemicals to destroy and kill pests is very harmful for farmers and also living organisms in the soil. Even chemicals such as insecticide, herbicides for plant diseases have been banned by some governments of certain countries, as the situation exists now, there is no botanical or environmental friendly chemical available. Due to this, farmers still use the chemicals for controlling pests on their farms. So, basically this technique provides an opportunity to employ environmentally friendly measures for pest control. The difference in the climatic factors such as the fall and rise in temperature unpredictably influences pest and disease incidence thereby impacting on major crops.

Therefore, the change in climate will affect the relationship of pest and weed and the host populations. However, some of the adaptation strategies in this pest management approach includes;

- (i) Improvement in different breeding types that are resistant to pest and disease.
- (ii) Strong pest adaptation mechanism with more relevant control for both biological and cultural practices.
- (iii) Adoption of techniques such as crop substitution with regards to places resistant to pest and hazards.

## GIS Mapping

This approach is used in analysis and mapping. It is a system which is designed to capture, store, manipulate, analyze, manage, and present geographical data.



Photo Credits:

Hazards - Republic of Nicaragua, Direccion de Hidrologia Superficial

Vulnerability - ©FAO, Thomas Hofer

Risk - ©FAO, Truls Brekke

**Fig. 3** Risk Assessment and mapping. (Source: Amin et al. 2016)



However, it helps in the estimation and computation of storm causes and flooding that is related to hot cyclones. The study in using GIS mapping considers factors such as property allocation, infrastructure facilities among other resources. The photograph and images (Fig. 3) were used in the experimentation of seashore due to rising sea levels and hot cyclones. The figure below shows risk which can be explained by the cumulative study of emerging threat and the existing patterns of vulnerability. The technique enables the creation of hazards and risk maps at many different possible scales or dimensions to show the threat allocation across different geographical spaces within the globe. Some of the geographical places can be site specific, municipal (administrative areas) and other natural landscapes in river basins, coastlines, and lakes. Figure 3 portrays Mapping and Risk Assessment.

---

## Conclusion

Climate change is a great threat to agriculture and as such there is the need to tackle this adverse impact by adopting new innovative techniques in climate smart agriculture. This chapter has dealt with some of the climate smart agriculture techniques that can help reduce the impacts of climate change on agriculture and increase food crop production. To achieve food security and agriculture development goals, adaptation to climate change will be required to lower emission intensities per output. Thus improving food protection by moderate climate change, sustainable use of the natural resources, using all products more competently, have less inconsistency and greater constancy in their outputs. More fruitful and more flexible agriculture requires a paramount change in the usage of resources such as land, water, soil nutrients, and genetic resources management by climate smart agriculture approaches.

---

## References

- Ahmad MI, Ali MA, Khan SR, Hassan SW, Javed MM (2014) Use of crop growth models in agriculture: a review. *Sci Int* 26(1):331–334, Lahore
- Amin A, Mubeen MHM, Nasim W (2016) Climate Smart agriculture: an approach for sustainable food security. *Agriculture Research Communications* 3:13–21
- Arslan A, Mccarthy N, Lipper L, Asfaw S, Cattaneo A, Kokwe M (2015) Climate smart agriculture? Assessing the adaptation implications in Zambia. *J Agric Econ* 66(3):753–780
- Baba RA, Owiyo T, Barbie B, Denton F, Rutabingwa F, Kiema A (2017) Advancing climate-smart agriculture in developing drylands: joint analysis of adoption of multiple on-farm soil and water conservation technologies in West African Sahel. *Land Use Policy* 61(2):196–207
- Basche AD (2015) Climate –smart agriculture in Midwest cropping systems: evaluating the benefits and trade-offs of cover crops. PhD Dissertation, Iowa State University
- Bochtis DD, Sorensen CGC, Busato P (2014) Advances in agricultural machinery management: a review. *Biosyst Eng* 126(10):669–681
- Boogaard H, De Wit A, Te Roller J, Van Diepen C (2014) Wofost control centre; users guide for the Wofost control centre and the crop growth simulation model Wofost 7. Alterra, Wageningen

- Branca G, Mccarthy N, Lipper L, Jolejole MC (2011) Climate smart agriculture: a synthesis of empirical evidence of food security and mitigation benefits from improved cropland management. Retrieved from <http://www.fao.org/climatechange/297640aa5796a4fb093b6cfd05558.pdf>.
- Burnisma J (2009) The resource outlook to 2050: By how much to land, water use and crop yields need to increase by 2050. Expert meeting on how to feed the world in 2050. FAO and ESDD, Rome, p 33
- Clements R, Hagggar J, Quezada A, Torres J (2011) In: Zhu X (ed) Technologies for climate change adaptation-adaptation sector. UNEP Riso Centre, Roskilde
- Derpsch R, Friedrich T, Kassam A, Li H (2010) Current status of adoption of no till farming in the world and some of its main benefits. *Int J Agric Biol Eng* 3:1–25
- FAO (2010) Climate- smart agriculture: policies, practices and financing for food security, adaptation and mitigation. Food and Agriculture Organization of the United Nations, Rome
- FAO (2011) The state of food and agriculture 2010–11. In: Women in agriculture: closing the gender-gap for development. Food and Agriculture Organisation of the United Nations, Rome
- Harterter J, Hamilton LC, Boag AE, Stevens FR, Ducey MJ, Christo ND, Palace MW (2017) Does it matter if people think climate change is human caused? *Clim Serv* 10(4):53
- Hulme M (2017) Climate change, concept of. *Int Encycl Geogr People Earth Environ Technol* 16. <https://doi.org/10.1002/9781118786352.wbieg0343>
- IPCC (2014a) Climate change: impacts, adaptation and vulnerability. Part A: Global and sectoral aspects. Contribution of working group II to the fifth assessment report for the intergovernmental panel on climate change. Cambridge University Press, Cambridge, UK/New York
- IPCC (2014b) Chapter 7: Food security and food production systems. In: Climate change 2014: impacts, adaptation, and vulnerability. IPCC working group II contribution to AR5. IPCC Secretariat, World Meteorological Organization, Geneva. Available: <http://ipccwg2.gov/images/uploads/WGIHARS5-Cha>
- IPCC (2018) Summary for policymakers. In: Global warming of 1.5 °C. An IPCC special report on the impacts of global warming of 1.5 °C above pre-industrial levels and related global greenhouse gas emission pathways, in the context of strengthening the global response to the threat of climate change, sustainable development and efforts to eradicate poverty [V. Masson-Delmotte, P. Zhai, H. O. Pörtner, D. Roberts, J. Skea, P. R. Shukla, A. Pirani, W. Moufouma-Okia, C. Pean, R. Pidcock, S. Connors, J. B. R. Mathews, Y. Chen, X. Zhou, M. I. Gomis, E. Lonnoy, T. Maycock, M. Tignor, Waterfield (eds)]. World Meteorological Organization, Geneva, 32p
- Katz RW (1977) Assessing the impact of climatic change on food production. *Clim Chang* 1:85–96
- Lipper L, Thornton P, Campbell BM, Baedeker T, Braimoh A, Bwalya M, Torquebiau EF et al (2014) Climate- smart agriculture for food security. *Nat Clim Chang* 4:1068–1072. <https://doi.org/10.1038/nclimate2437>
- Matocha J, Schroth G, Hills T, Hole D (2012) Integrating climate change adaptation and mitigation through agroforestry and ecosystem conservation. In: Nair PKR, Garrity D (eds) Agroforestry-the future of global land use. Springer, Dordrecht, pp 105–126
- Met Office (2015) Food insecurity and climate change model spread. Retrieved from <http://www.metoffice.gov.uk/food-insecurity-index>
- Pathak H (2009) Agriculture and environment. In: Handbook of agriculture. Directorate of Information and Publication Agriculture, ICAR, New Delhi, pp 62–92
- Pathak H, Aggarwal PK, Singh SD (eds) (2012) Climate change impact, adaptation and mitigation in agriculture: methodology for assessment and applications. Indian Agricultural Research Institute, New Delhi, p 302
- Richardson KJ et al (2018) Food security outcomes under a changing climate: impacts of mitigation and adaptation on vulnerability to food insecurity. *Clim Chang*. <https://doi.org/10.1007/s10584-0182137-y>
- Rural Poverty Report (2011) International fund for agriculture development
- Shames S, Wollenberg E, Buck LE, Kristjanson P, Masiga M, Biryahaho B (2012) Institutional innovations in Africa smallholder carbon projects. CCAFS Report No. 8. Copenhagen, CCAFS

- Smith P, Olesen J (2010) Synergies between the mitigation of, and adaptation to climate change in agriculture. *J Agric Sci* 148:54–552. <https://doi.org/10.1017/S0021859610000341>
- Tol RSJ (2018) The economic impacts of climate change. *Rev Environ Econ Policy* 12:4–25
- UNFPA (2011) Annual Report: Delivering Results in a World of 7 billion, New York
- WB (2016a) World Data Bank –agriculture indicators. The World Bank, Washington, DC. Accessed 05 June 2020
- WB (2016b) World Data Bank–agriculture indicators. The World Bank, Washington, DC. Accessed 05 June 2018
- Wheeler T, von Braun J (2013) Climate change impacts on global food security. *Science* 341:508–513
- Wilbanks T, Sathaye J (2007) Integrating mitigation and adaptations responses to climate change: a synthesis. *Mitig Adapt Strateg Glob Chang* 12(5):957962. [https://doi.org/10.1007/s110270079108\\*3](https://doi.org/10.1007/s110270079108*3)
- Zougmore R, Partey S, Ouedraogo M, Omitoyin B, Thomas T et al (2016) Toward climate-smart agriculture in West Africa: a review of climate change impacts, adaptation strategies and policy developments for the livestock, fishery and crop production sectors. *Agriculture and Food Security* 5(1):26

**Open Access** This chapter is licensed under the terms of the Creative Commons Attribution 4.0 International License (<http://creativecommons.org/licenses/by/4.0/>), which permits use, sharing, adaptation, distribution and reproduction in any medium or format, as long as you give appropriate credit to the original author(s) and the source, provide a link to the Creative Commons license and indicate if changes were made.

The images or other third party material in this chapter are included in the chapter's Creative Commons license, unless indicated otherwise in a credit line to the material. If material is not included in the chapter's Creative Commons license and your intended use is not permitted by statutory regulation or exceeds the permitted use, you will need to obtain permission directly from the copyright holder.





# Sorghum Farmers' Climate Change Adaptation Strategies in the Semiarid Region of Cameroon

8

Salé Abou, Madi Ali, Anselme Wakponou, and Armel Sambo

## Contents

Introduction .....	148
Socioeconomic Characteristics of the Sorghum Farmers .....	149
Climate Hazards and Sorghum Farmers' Adaptation Strategies .....	149
Sahelian Farmers Adaptation Strategies' Typologies .....	153
First Category of Typologies .....	154
Second Category of Typologies .....	156
Third Category of Typologies .....	157
Characterization of Sorghum Farmers' Adaptation Strategies .....	157
Conclusion .....	163
References .....	164

## Abstract

This chapter deals with the problem of sorghum farmers' adaptation to climate change in the semiarid region of Cameroon. Its general objective is to compare the various adaptation strategies' typologies and to characterize the sorghum farmers' adaptation strategies on the basis of the suitable one. The stratified

This chapter was previously published non-open access with exclusive rights reserved by the Publisher. It has been changed retrospectively to open access under a CC BY 4.0 license and the copyright holder is "The Author(s)". For further details, please see the license information at the end of the chapter.

S. Abou (✉) · M. Ali

National Advanced School of Engineering of Maroua (ENSPM), The University of Maroua, Maroua, Cameroon

A. Wakponou

Faculty of Arts, Letters and Human Sciences (FALSH), The University of Ngaoundéré, Ngaoundéré, Cameroon

A. Sambo

Faculty of Arts, Letters and Human Sciences (FALSH), The University of Maroua, Maroua, Cameroon

© The Author(s) 2021

W. Leal Filho et al. (eds.), *African Handbook of Climate Change Adaptation*, [https://doi.org/10.1007/978-3-030-45106-6\\_41](https://doi.org/10.1007/978-3-030-45106-6_41)

147

random sampling method was used to select the sites, which consist of twenty (20) villages, and the sample, which consists of six hundred (600) farm household heads. After conducting focus-groups in ten villages and interviews with resource persons, the primary data were collected using a semi-open survey questionnaire. It appears that the poor spatiotemporal distribution of rains and the drought constitute, respectively, the main climate hazard and the main water risk that farmers are dealing with; the farmers are vulnerable to climate change because the adaptation strategies used are mostly traditional, their adoption rates are very low, and the use of efficient adaptation strategies (irrigation, improved crop varieties) is almost unknown. The characterization of the adaptation strategies used shows that they are more complex than most authors who have established the typologies thought. It comes out that improving the resilience of these sorghum farmers absolutely requires the improvement of their basic socioeconomic conditions.

---

**Keywords**

Semi-arid region · Sorghum farmers · Climate change · Climate hazard · Water risk · Adaptation strategies

---

## Introduction

Farmers in the semi-arid regions of Africa, to which belongs the Diamaré division in the Far North Cameroon, are among the most vulnerable to water constraints caused by climate variability during the 1960s and 1970s. This vulnerability has its origin in their essentially rain-fed agriculture, their unfavorable socioeconomic characteristics, and their very fragile ecosystem.

According to Borton and Nicholds (1994), of all-natural hazards, droughts are the ones with the greatest economic impact, and affecting the greatest number of people. In the Diamaré division, as in the whole semi-arid zone of Cameroon, water constraints, particularly droughts and floods, have had a negative impact on cereals' production, especially sorghums, which constitute the basic food of the population. According to L'hôte (2000), the period called "Drought in the Sahel" was an agronomic disaster for the entire region. Similarly, the results of the simulations carried out by Blanc (2012), compared to a reference without climate change, indicate that sorghum yields could decrease by around  $-47\%$  to  $-7\%$  by 2,100 in this region. Faced with this situation, a wide variety of adaptation strategies emanating from both farmers and agricultural research has been made available to sorghum farmers, but adoption rate remains low as everywhere else in the African semi-arid zones (Yesuf et al. 2008; Leary Kulkarni and Seipt 2007).

In order to better understand the main orientations of these various adaptation strategies, a variety of typologies has been previously established by some authors (Dingkuhn 2009; Nhemachena and Hassan 2007; Jouve 2010; then Fabre 2010); but a comparison between adaptation strategies on the basis of these typologies remains difficult because of the diversity of analysis' angles used by the authors. For this reason, it seems better to identify the main similarities and differences between the

various typologies, and then to characterize the sorghum farmers' adaptation strategies on the basis of the most suitable typology. The sorghum farmers' adaptation strategies' characterization could allow researchers as well as policy-makers to better reorient research priorities and policies in order to improve farmers' resilience.

The Diamaré division located in the Far-North region of Cameroon (Fig. 1), between 10° and 11° North latitude (10°30'00") and 14° and 15° East longitude (14° 30'00"), constituted the focus area. The climate is Sudano-Sahelian in its southern part and Sahelo-Sudanian in its northern part, all characterized by a long dry season (7–9 months), and a short rainy season. Agriculture (rainy season, dry season), animal husbandry, fishing, trade, and crafts are the main activities of these populations.

The information has been collected through directed interviews with some resource people (researchers, patriarchs, heads of technical services), and then focus groups and a survey questionnaire submitted to six hundred (600) household heads. The descriptive and inferential statistics (frequencies, percentages, Principal Component Analysis, Kaiser-Meyer-Olkin/KMO test) from the SPSS statistical software have been used to analyze the information gathered.

---

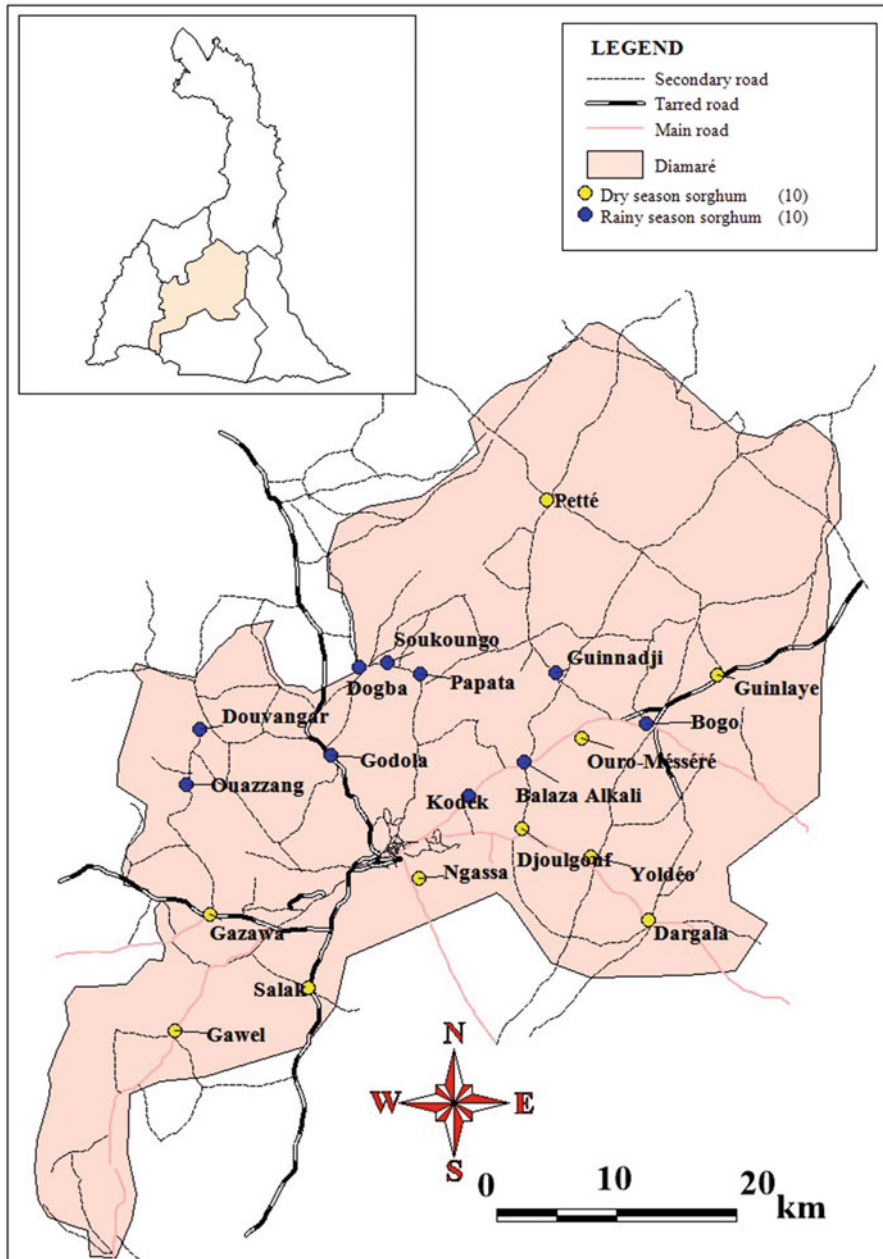
## Socioeconomic Characteristics of the Sorghum Farmers

In general, agriculture and livestock are the main activities of the farmers, and the Diamaré division is one of the three divisions most exposed to food insecurity in the region. Priority is given to cereals in terms of land mobilization and work (CEDC 2010), and sorghum (rainy and dry seasons) constitute the staple food of the populations. This agriculture is essentially characterized by the practice of polyculture (93.80%) and self-consumption agriculture (79%), the small size of the sown areas (100% < 10 ha, with areas varying between 0,5 ha and 1 ha for sorghum), the low quantity of agricultural inputs used (FAO 2009), the poor access to agricultural supervision (51.50%), and to credits (43.50%). Cotton and onion are the only export crops. In order to ensure their daily survival, these farmers multiply income-generating activities (65.50%), which reflects the inability of agricultural activities to meet their food needs, and therefore their high vulnerability. The household heads are mostly men, most of them aged between 35 and 54 years (FAO 2009), with an average age of 48 years in Diamaré. The average household size is around 9 people, and seems to be high compared to a regional average of 7 and a national average of 5.7. The school enrollment rate, which is 57%, is the lowest in the country, with 39.30% having reached primary, 17% secondary, and less than 1% (0.4%) higher education. Health and school infrastructures are among the least fortunate in the country.

---

## Climate Hazards and Sorghum Farmers' Adaptation Strategies

Table 1 summarizes the climate hazards imposed by the climate change to the rainy and dry seasons' sorghum production.



**Fig. 1** The Diamaré division in the Far-north region of Cameroon

**Table 1** Climate hazards perceived by rainy and dry seasons sorghums' farmers

Climate hazards	Rainy season sorghum		Dry season sorghum	
	Total	%	Total	%
Late or early arrival of rains	300	100	297	99
Early cessation of rains	300	100	293	97,67
Poor spatial rainfall distribution	299	99,67	299	99,67
More frequent and long dry spells	300	100	300	100
Flooding of crops	300	100	294	98
General decline in the total amount of rainfall	299	99,67	296	98,67
Rapid drying of water sources (ponds, rivers, lakes, wells)	–	–	300	100
Rapid drying and hardening of soils	–	–	292	97,33
Light rains at the beginning of the rainy season	–	–	297	99
Absence of heavy rains at the end of the rainy season	–	–	297	99
No haze during cold season	–	–	299	99,67

Most of the climate hazards listed relate to the poor spatiotemporal distribution of rains, while most of them are linked to drought, and not to excess water (floods); that means the poor spatiotemporal distribution of rains is the main climate hazard while drought is the main water risk limiting agricultural production both during the rainy and dry seasons in the area. This observation confirms the results obtained by Chédé (2012), Gnanglé et al. (2012), then Agossou et al. (2012).

Likewise, it emerges that all the three known forms of drought are represented here:

- Meteorological drought (late arrival of the rains, early start of the rains, dry spells, decrease in the amount of rains, light rains at the start of the rainy season, light rains at the end of the rainy season)
- Agricultural drought (rapid drying and hardening of soils)
- Hydrological drought (rapid drying up of ponds and rivers)

According to FAO and National Drought Mitigation Center (2008), when all of these three forms of drought rage somewhere, automatically, the socioeconomic drought which is their logical consequence, will also rage there; and that is noticeable through the socioeconomic characteristics of the sorghum farmers described in the previous paragraph.

One can also remark the high rate of climate hazards' perception by the farmers, which could reflect both the extent and the severity of these constraints, but also a good perception of the phenomena by farmers who control their physical environment. Indeed, Arodokoun (2011) considers that, in general, peasant communities which maintain close links with their environment have a perfect knowledge of the climate, its manifestations and the changes that have occurred. This situation could



also be justified by the fact that according to Nhemachena and Hassan (2007), climate change has very negative effects on the poorest households which have the least capacity to adapt to changing climatic conditions.

It appears also that all the climate hazards affecting rain-fed sorghums also affect dry season sorghums; which reflects the strong dependence of dry season sorghum on meteoric water. On the other hand, the multiplicity of climate hazards affecting dry season sorghum can be explained by the diversity of the water resources (meteoric, surface, underground) essential to its production.

The adaptation strategies in use by sorghum farmers in the face of these climate hazards and water risks are summarized in Table 2.

The analysis of the nature of the adaptation strategies used by sorghum farmers in the face of climate hazards and water risks could lead to the following remarks:

- All the adaptation strategies used by sorghum farmers aim to compensate for either the poor distribution of rains, the droughts (meteorological, edaphic, hydrological, socioeconomic), or to both of the two types of constraints.
- An overwhelming majority of these adaptation strategies have been adopted to cope with meteorological drought, which is the main form of drought faced by sorghum farmers; it is followed by edaphic drought, then hydrological drought.

**Table 2** Nature and frequency of adoption of the adaptation strategies used by sorghum farmers

Adaptation strategies	Rainy season sorghum		Dry season sorghum	
	Total	(%)	Total	(%)
Sowing early matured varieties	131	43,67	175	<b>58,33</b>
Sowing or transplanting early	178	<b>59,33</b>	139	<b>46,33</b>
Sowing of drought resistant crops varieties	178	<b>59,33</b>	194	<b>64,67</b>
Diversification of crops varieties	94	31,33	182	<b>60,67</b>
Changing of crops or crops' varieties	105	35	25	08,33
Labor of plots and mounding of plants	234	<b>78</b>	96	32
Temporary or permanent transfer of crops	170	<b>56,67</b>	30	10
Making of racks or bunds	103	34,33	203	<b>67,67</b>
Nursery organic or inorganic fertilizer input	271	<b>90,33</b>	82	27,33
Diversification of income-generating activities	195	65	141	47
Crops diversification	268	<b>89,33</b>	272	<b>90,67</b>
Multiplication of weeding	123	41	20	06,67
Sowing of molten seed holes or dried plants	166	<b>55,33</b>	05	01,67
Rocky bunds	05	01,67	–	–
Late transplanting	–	–	125	<b>41,67</b>
Deepening piles	–	–	129	43
Purchase or request of nurseries	–	–	104	34,67
Scaling of nurseries over the time	–	–	203	<b>67,67</b>
Organic or inorganic fertilization of nurseries	–	–	107	35,67
Cleaning and deepening of ponds	–	–	131	<b>60,33</b>
Water research over long distances	–	–	95	31,67
Fertilization of transplanting water	–	–	06	02

- Despite the identification of floods as another main water risk by sorghum farmers, no adaptation strategy has apparently been adopted by them to deal with it.
- The adaptation strategies used are traditional in their majority, and those recognized as efficient such as the irrigation or the use of improved crops' varieties are almost unused.
- Despite the traditional nature of the adaptation strategies used, their adoption rates by farmers are low in the majority of cases.

The synthesis of these preceding remarks conducts to the following conclusions:

- The poor spatiotemporal distribution of rains and the drought (especially meteorological), constitute, respectively, the main climate hazard and the main water risk faced by farmers in the area; this has been previously confirmed by several researchers including Batterbury and Mortimore (2013), then Mortimore and Adams (2000), who consider that all the Sahelian farmers' problems correspond to a group of "five (5) crises of the Sahelian orthodoxy," to which they are trying to provide solutions, the main one of which is represented by drought.
- Sorghum farmers in particular and farmers in general from the region are very vulnerable because they do not really adapt to but they simply cope with the climate change; this confirms the observation made by the IPCC (2014), Sissoko et al. (2010), OECD (2010), then Leary et al. (2007), according to whom Sahelian farmers do not adapt to but simply cope with climate change; these sorghum farmers' maladaptation (lack of adaptation) can be perceived or explained from the previous paragraph 1 through the practice of self-consumption agriculture, the small size of the sown areas, the low quantity of agricultural inputs used, the poor access to agricultural supervision and to credits, the multiplication of income-generating activities, and the weak school enrollment rate. Contrary to this result, authors like Jouve (2010) and Batterbury and Forsyth (1999) find that in fact Sahelian farmers adapt to climate change. This duality of contradictory observations could be justified either by the different use of the concept of adaptation, or by the difference in the results obtained in different contexts.

---

## Sahelian Farmers Adaptation Strategies' Typologies

On the whole, the farmers' adaptation strategies in the dry regions (semiarid, arid) can be classified both on the basis of farmers' practices, which takes into account all the actions undertaken by them to ensure their survival, and on the basis of the agricultural research, which is only interested in crop management. According to these two angles of analysis, the typologies could be grouped into three main categories:

- The first category of typologies, proposed by Nhemachena and Hassan (2007), Jouve (2010), Ngigi (2009), Diarra (2008), Fabre (2010), then Batterbury and Mortimore (2013).
- The second category of typologies brings together those proposed by Batterbury and Forsyth (1999), then Ngigi (2009).
- The third category of typologies, which corresponds to that proposed by Dingkuhn (2009).

## First Category of Typologies

The first category of typologies is that proposed by Nhemachena and Hassan (2007), Jouve (2010), Ngigi (2009), Diarra (2008), Fabre (2010), then Batterbury and Mortimore (2013). These typologies distinguish adaptation strategies which consist of facing risks from those focusing on avoiding risks.

In general, Nhemachena and Hassan (2007) estimate that there are roughly two types of adaptation strategies in agricultural production systems:

1. The strategies which are based on “confronting water risks,” essentially based on increasing diversification which corresponds to the adoption of production activities tolerant to drought and/or resistant to thermal stress, as well as activities that relate to efficient management that value the quantity of water available and ambient temperatures among other factors.
2. The strategies which are based on “eviction of water risks,” essentially based on crop management practices, and which consist in avoiding that the critical stages of plant growth do not coincide with bad climatic conditions such as inter-season droughts (modification of the crop cycle and modification of sowing and harvest dates).

Jouve (2010), Ngigi (2009), and Diarra (2008), based on the subjective assessment of risks and vulnerability, have grouped the farmers’ adaptation strategies into three (3) categories:

1. The “pre-risk” or preventive management options (prevention strategies) or before risks, such as the choice between risk-tolerant varieties, investment in water management, and diversification of survival and agriculture, well before the arrival of the growing season.
2. The “intra-season” adjustment of crops and resources management options in response to constantly changing specific climatic shocks, also called “adaptive methods” or “mitigation strategies”; these are peasant innovations put in place to adapt to climate change and to make the best use of rainwater resources.
3. The “post-risk” management options or “palliative methods” or “adjustment strategies,” which minimize the impacts of adverse climate shocks; they seek to mitigate the effects of climatic risks which particularly affect poor rural

populations; these methods, based on the establishment of insurance systems, aim to stabilize farmers' incomes and avoid their indebtedness and decapitalization during bad years; they are intended to alleviate the impact of the event when it happened.

The comparison between these two typologies indicates that they are identical: the strategies based on "confronting water risks" proposed by Nhemachena and Hassan (2007) correspond to the intra-season adjustment and post-risk" management options in the typology proposed by Jouve (2010), Ngigi (2009), and Diarra (2008), while "crowding out water risks" corresponds to "pre-risk" management options.

Batterbury and Mortimore (2013) estimate that the Sahelian farmers' adaptation strategies correspond to the five crises of Sahelian orthodoxy:

- The management of rainfall by farmers each year
- The integration of agriculture and animal husbandry
- The conservation management of biodiversity
- The intensive and sustainable soil management
- The diversification of livelihoods

Jouve (2010) and Fabre (2010), for their part, believe that sahelian farmers' adaptation strategies to climate variability can be split into three (3) groups:

- The choice of crops (species, varieties)
- The modification of practices (irrigation and drainage, polyculture, modification of the cropping calendar)
- The modification of sources of income (crafts, livestock, trade, etc.)

Reconciling the last two typologies also indicates that they are similar insofar as the management of rainfall, the integration of agriculture and animal husbandry, and the intensive and sustainable management of soil suggested by Batterbury and Mortimore (2013) corresponds to the modification of practices suggested by Jouve (2010) and Fabre (2010). Similarly, the conservation management of biodiversity corresponds to the choice of crops, while the diversification of livelihoods corresponds to the modification of sources of income.

Finally, the comparison between the two previous typologies and the two last ones indicates that they are in fact similar. The "increase in diversification" proposed by the first two typologies corresponds to the "modification of the sources of income and the practices" proposed by the two last ones, while the crop "management practices" correspond to the "choice of crops"; this amounts to saying that in terms of farmers' practices, the four typologies are identical.

The particularity of this first category of typologies is that they are based principally on the natural agro-pastoral resources (water, soils, crops, animals) spatiotemporal management.

## Second Category of Typologies

The second category of typologies includes those proposed by Batterbury and Forsyth (1999), then Ngigi (2009). These typologies distinguish “adaptive processes” which are long and medium terms adaptation strategies, from “adaptive strategies” which are short term actions intended to ensure the survival of farmers.

Batterbury and Forsyth (1999) find that farmers’ adaptation strategies can be divided into two categories:

- The “adaptive processes,” which generally call for a spatial extension of activities outside the locality, in order to reduce the pressure on local resources; it is an appropriate strategy for communities in dry regions where diversification is the main response to drought or crop failure; adaptation processes are long-term transitions that change the configuration of relationships between a community and its resources; each transition has several components, and adoption and the form that transition takes depends on several factors of change, such as farmers’ knowledge, the biophysical environment (especially precipitation and soil), and availability of the work force; for this reason, each transition will be relatively unique, thus reflecting the interactions between farmers, their institutions, their economic policy, and their environment.
- The “adaptive strategies” are short-term practices, adopted in response to sudden shocks or difficulties in accessing resources.

Ngigi (2009) differentiate adaptation strategies to climate change between:

- “Adaptation itself” or “adaptation strategies,” which constitutes a change in response to changing climatic parameters and
- “Coping mechanisms” or “coping strategies,” generally in the short term.

The comparison between these two typologies shows that they are also similar. “Adaptation itself” corresponds to “adaptive processes,” while “coping strategies” correspond to “adaptive strategies.”

This category of typologies is characterized by the fact that tries to differentiate the farmers’ adaptation strategies, either on the long- and medium-terms use of agricultural or nonagricultural strategies to truly adapt climate change, or on the short-term use of agricultural or nonagricultural strategies to cope with climate change (without really adapting to it); in other words, it differentiates farmers’ adaptation strategies based on whether they are genuinely adapting in the long- to medium-terms, or whether they are simply coping in a short-term with climate change to just ensure their survival.

### Third Category of Typologies

The typology proposed by Dingkuhn (2009), corresponds to the third category, and groups adaptation strategies according to the agricultural research fields, into four very distinct types:

- Genetic adaptation (drought resistant varieties, early varieties)
- Agronomic adaptation (all the strategies linked to the management of crops, which are the most numerous)
- Geographic adaptation (temporary or permanent change in cultures)
- Temporal adaptation (early sowing, late sowing, staggering of nurseries)

The particularity of this category of typologies is that it is not interested in the climate hazards or risks that farmers are facing (first category of typologies), nor in the strength or weaknesses of the adaptation strategies in use (second category of typologies), but simply to the scientific field to which each of these adaptation strategies relates.

The comparison between all the previous typologies and the current one proposed by Dingkuhn (2009) indicates that one could very well transpose the genetic, agronomic, geographic, and temporal adaptations suggested by this typology in these ones; however, the socioeconomic adaptation taken into account by these typologies does not exist in the one proposed by Dingkuhn (2009), and this could be explained by the fact that this typology is essentially concerned with crop management and not with farmers practices in their whole.

After a careful analysis of the typologies' categories and the sorghum farmers' adaptation strategies, it appears that it is appropriate to characterize them on the basis of the first category of typologies because both (category of typologies, adaptation strategies) are oriented towards the agro-pastoral natural resources' management; on the other hand, while the second category of typologies requires the strategies to be monitored over time in order to assess their effectiveness, the third category is more descriptive and does not allow to grasp easily the real objectives targeted by sorghum farmers.

---

### Characterization of Sorghum Farmers' Adaptation Strategies

The adaptation strategies were grouped according to crops, so first, the adequacy of the rainy season sorghum farmers' adaptation strategies has been tested using the KMO test. The results are listed in Table 3.

All the KMO values taken by the different adaptation strategies being greater than 0.49, all these strategies have been used in the test.

**Table 3** Results of the KMO sample adequacy test applied to the rainy season sorghum farmers' adaptation strategies

Adaptation strategies	Codes	KMO values
Sowing early matured varieties	SEVARPRE	0.834
Sowing or transplanting early	SEMISSEC	0.743
Sowing of drought resistant crops varieties	SEMVARES	0.817
Diversification of crops varieties	DIVARCUL	0.896
Change of crops or crops varieties	CHASPVA	0.671
Labor of plots and mounding of plants	LABBUTPL	0.815
Temporary or permanent transfer of crops	MUTEDECU	0.858
Making of racks	CONFCAS	0.925
Organic fertilizer input	FUMORGA	0.849
Diversification of income-generating activities	DIVACGER	0.854
Crops' diversification	DIVERCUL	0.850
Multiplication of weeding	MULTSARC	0.867
Sowing of molten seed holes or dried plants	RESREPIQ	0.845

The eigenvalues of the various factors from the PCA results reveal the existence of two (2) main factors, which explain 53.64% (>49%) of the total variation of the adaptation strategies, in accordance with the KMO rule (Fig. 2 and Table 4).

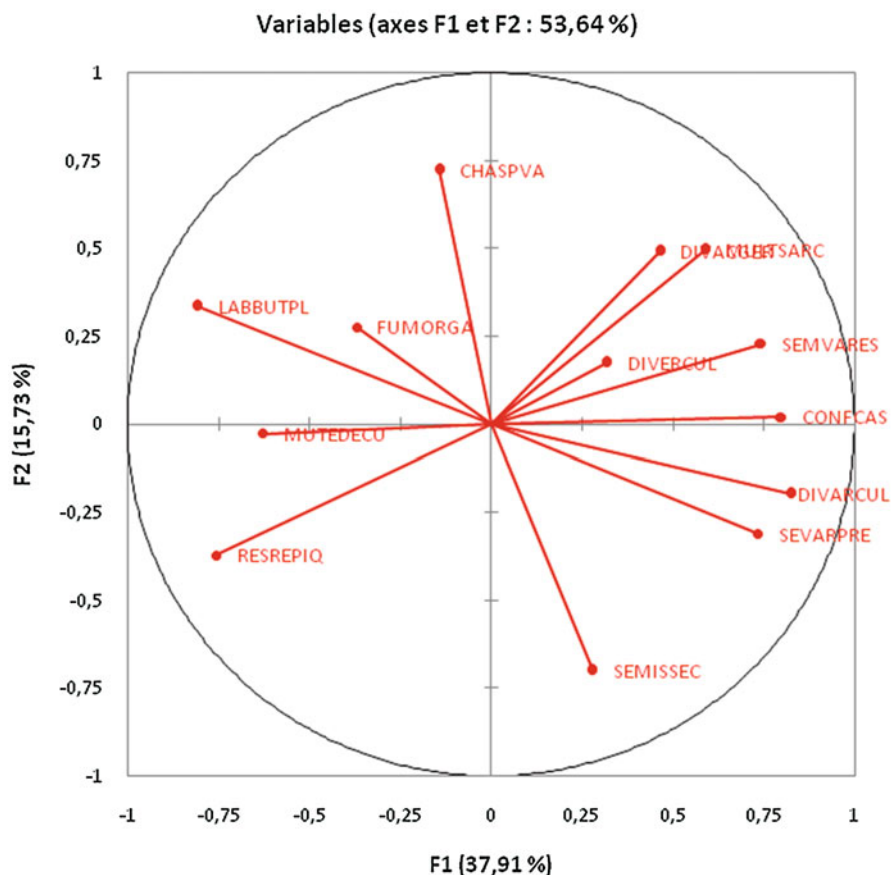
Loading these adaptation strategies according to the two main factors gave the results mentioned in Table 5.

Factor 1 brings together the adaptation strategies “sowing of early matured varieties,” “diversification of crop varieties,” “change of crops or crop varieties,” “labor of plots and mounding of plants,” “temporary or permanent transfer of crops,” “organic or mineral fertilizer input,” and “sowing of melted seed holes or dried plants.” This factor can be called “Adaptation to climate hazards through efficient management of natural resources (soil, water, crops).” This factor can be interpreted as the decision-making by farmers to continue to carry out agricultural activities despite the risks, and corresponds in fact to the adaptation strategy by “**confronting climate hazards and water risks**” suggested by the first category of typologies.

Factor 2 groups together the adaptation strategies “sowing or transplanting early,” “sowing of drought resistant crops varieties,” “making of racks,” “diversification of income-generating activities,” “crop diversification,” and “multiplication of weeding.” This factor brings together adaptation strategies whose main objective is to avoid water risks.

It therefore corresponds to all the activities carried out by farmers with the aim of minimizing climate hazards and water risks and their impacts; and for that, it corresponds well to the adaptation strategy by “**eviction or minimization a priori of climate hazards and water risks**” suggested by the first category of typologies.

It finally emerges from this analysis that all the rainy season sorghum farmers' adaptation strategies correspond very well to the typology proposed by the first category of typologies' authors, namely adaptation by “**confronting water risks**” and adaptation by “**a priori eviction or minimization of water risks**”.



**Fig. 2** Percentage explanations of variables by factors F1 and F2

**Table 4** Variability explained by factor

Factors	Variation	%	Cumulative %
F1	4.928	37.908	37.908
F2	2.045	15.731	<b>53.64</b>

The test of the adequacy of the dry season sorghum farmers' adaptation strategies using the KMO test gave the results mentioned in Table 6.

All the KMO values taken by the adaptation strategies are greater than 0.49, except that of the "late transplanting" strategy, which will not be used in the KMO test.

The eigenvalues of the different factors from the PCA results reveal the existence of five (5) main factors, which explain 53.612% (>49%) of the total variation of the adaptation strategies, in accordance with the KMO rule. (Fig. 3 and Table 7).

Loading the adaptation strategies of the dry season sorghum farmers according to the five (5) main factors gave the results mentioned in Table 8.



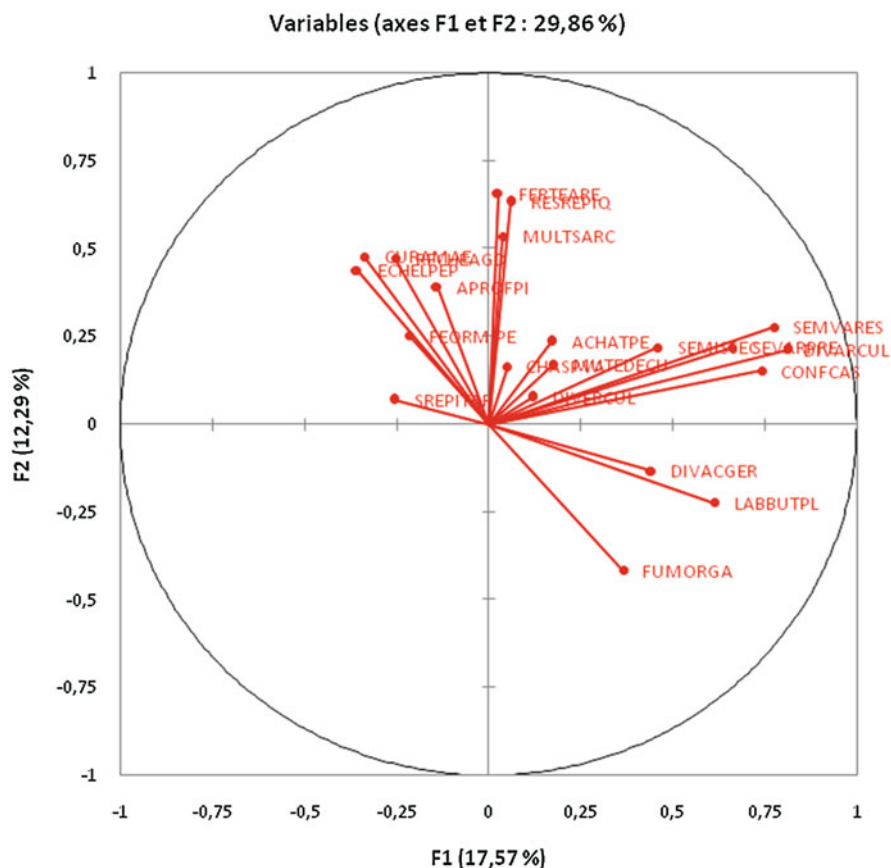
**Table 5** Results of the loading of the rainy season sorghum farmers' adaptation strategies by factor

Adaptation strategies	Factor 1	Factor 2
Sowing early matured varieties	<b>-0.570</b>	0.067
Sowing or transplanting early	-0.444	<b>-0.511</b>
Sowing of drought resistant crops varieties	-0.267	<b>0.513</b>
Diversification of crops varieties	<b>-0.712</b>	0.292
Change of crops or crops varieties	<b>0.582</b>	0.475
Ploughing of plots and mounding of plants	<b>0.862</b>	-0.217
Temporary or permanent transfer of crops	<b>0.540</b>	-0.424
Making of racks	-0.572	<b>0.456</b>
Organic or mineral fertilizer input	<b>0.554</b>	-0.052
Diversification of income-generating activities	-0.127	<b>0.697</b>
Crops' diversification	0.133	<b>0.163</b>
Multiplication of weeding	-0.077	<b>0.690</b>
Sowing of melted seed holes or dried plants	<b>03.65</b>	-0.735

**Table 6** Results of the KMO sample adequacy test applied to the dry season sorghum farmers' adaptation strategies

Adaptation strategies	Codes	KMO values
Sowing of early matured varieties	SEVARPRE	0.817
Sowing or transplanting early	SEMISSEC	0.577
Sowing of drought resistant crops varieties	SEMVARES	0.743
Diversification of crops varieties	DIVARCUL	0.782
Change of crops or crops varieties	CHASPPVA	0.522
Ploughing of plots and mounding of plants	LABBUTPL	0.801
Temporary or permanent transfer of crops	MUTEDECU	0.540
Making of racks or bunds	CONFICAS	0.771
Crops organic or inorganic fertilizer input	FUMORGA	0.773
Diversification of income-generating activities	DIVACGER	0.731
Crops diversification	DIVERCUL	0.500
Multiplication of weeding	MULTSARC	0.687
Sowing of molten seed holes or dried plants	RESREPIQ	0.621
Late transplanting	SREPITAR	0,444
Deepening piles	APROFPI	0.555
Purchase or request of nurseries	ACHATPE	0.663
Scaling of nurseries over the time	EHELPEP	0.780
Organic or inorganic fertilization of nurseries	FEORMIPE	0.568
Cleaning and deepening of ponds	CURAMAE	0.753
Water research over long distances	RECHEAGD	0.739
Fertilization of transplanting water	FERTEARE	0.585

Factor 1 groups together the adaptation strategies “sowing of early matured varieties”, “sowing of drought-tolerant varieties”, “diversification of crop varieties”, “ploughing of plots and mounding of plants”, “making of racks or bunds”, and



**Fig. 3** Percentage of explanations of variables by factors F1 and F2

**Table 7** Variability explained by factor

Factors	Variation	%	Cumulative %
<b>F1</b>	3.690	17.571	17.571
<b>F2</b>	2.581	12.292	29.863
<b>F3</b>	2.132	10.151	40.014
<b>F4</b>	1.561	7.434	47.447
<b>F5</b>	1.295	6.165	<b>53.612</b>

“diversification of income-generating activities”. This factor brings together all of the farmers’ adaptation strategies which aim to avoid or minimize water risks and their impacts, and in fact corresponds to the adaptation strategy by “**a priori eviction or minimization of water risks**” suggested by the first category of typologies.

Factor 2 groups together the adaptation strategies “multiplication of weeding”, “sowing of melted seed holes or dried plants”, “deepening of piles”, “scaling of nurseries over the time”, “cleaning and deepening of ponds”, “water research over

**Table 8** Results of the loading of the dry season sorghum farmers' adaptation strategies by factor

Adaptation strategies	Factor 1	Factor 2	Factor 3	Factor 4	Factor 5
Sowing of early matured varieties	<b>0.663</b>	0.219	-0.100	0.194	0.149
Sowing or transplanting early	0.459	0.219	-0.168	-0.163	<b>0.596</b>
Sowing of drought resistant crops varieties	<b>0.777</b>	0.277	-0.307	0.124	-0.240
Diversification of crops varieties	<b>0.813</b>	0.213	-0.246	0.075	-0.160
Change of crops or crops varieties	0.052	0.165	-0.052	<b>0.487</b>	-0.248
Ploughing of plots and mounding of plants	<b>0.613</b>	-0.224	0.352	-0.070	-0.107
Temporary or permanent transfer of crops	0.176	0.170	0.243	-0.035	<b>-0.391</b>
Making of racks or bunds	<b>0.743</b>	0.152	-0.349	0.055	-0.171
Crops organic or inorganic fertilizer input	0.367	-0.416	<b>0.445</b>	0.029	0.140
Diversification of income-generating activities	<b>0.443</b>	-0.133	0.428	0.158	0.387
Crops diversification	0.120	0.077	-0.220	<b>-0.222</b>	0.194
Multiplication of weeding	0.039	<b>0.535</b>	0.410	-0.154	-0.272
Sowing of melted seed holes or dried plants	0.061	<b>0.633</b>	0.464	-0.312	0.019
Deepening of piles	-0.139	<b>0.392</b>	-0.287	0.033	0.222
Purchase or request of nurseries	0.172	0.236	0.245	<b>0.469</b>	0.297
Scaling of nurseries over the time	-0.357	<b>0.438</b>	-0.386	-0.007	0.084
Organic or mineral fertilization of nurseries	-0.215	0.253	0.262	<b>0.418</b>	0.245
Cleaning and deepening of ponds	-0.337	<b>0.477</b>	-0.359	-0.023	-0.038
Water research over long distances	-0.251	<b>0.471</b>	0.049	0.389	0.143
Fertilization of transplanting water	0.026	<b>0.657</b>	0.498	-0.401	-0.016

long distances”, and “fertilization of transplanting water”. This factor brings together all the adaptation strategies aimed at the sustainable management of water resources, and can be called “**Adaptation to water risks by efficient management of water resources**”.

Factor 3 contains the “crops organic or inorganic fertilizer input” strategy. It brings together strategies aimed at sustainable soil management, and can be called “**Adaptation to water risks through efficient soil management**”.

Factor 4 groups together the strategies “change of crops or crop varieties”, “crops diversification”, “purchase or request of nurseries”, and “organic or mineral fertilization of nurseries”. It brings together strategies aimed at the sustainable management of crops, and can be called “**Adaptation to water risks through sustainable management of crops**”.

Factor 5 groups together the strategies “sowing or transplanting early” and “temporary or permanent transfer of crops”, which aim to avoid water risks, and can be called “**Adaptation by a priori eviction of water risks**”.

Analysis of all the five factors reveals that factors 1 and 5 correspond to the farmers' adaptation to climate change by "**eviction or a priori minimization of water risks**", while factors 2, 3, and 4 correspond to their adaptation by "**confronting water risks**"; and therefore, it could be said that the dry season sorghum farmers' adaptation strategies corresponds very well to the typology proposed by the authors of the first category of typologies, namely, adaptation by "confrontation with the water risks" and adaptation by "a priori eviction or minimization of the water risks."

That said, depending on the results of the characterization of the sorghum farmers' adaptation strategies using PCA and KMO test, their whole adaptation process can be explained through a set of two actions:

1. The agro-pastoral natural resources management by "confrontation with the climate hazards and water risks" or by "eviction of the climate hazards and water risks".
2. The intense spatiotemporal diversification of the practices (agro-pastoral natural resources management, income generating activities).

Finally, it can be said that the characterization of the sorghum farmers' adaptation strategies shows that they are more complex than most authors who have established the typologies thought, because of the spatiotemporal diversification of the practices.

---

## Conclusion

At the end of this chapter, we could draw the following conclusions:

- The poor spatiotemporal distribution of rains and the drought respectively constitute the main climate hazard and the main water risk faced by sorghum farmers in particular, and farmers in general in the semi-arid region of Cameroon.
- The sorghum farmers are highly vulnerable to climate change, and that could be perceived through the coexistence of all the three forms of drought (meteorological, agricultural, hydrological), the permanent food insecurity, the mostly traditional adaptation strategies used and their very low adoption rates, the underuse or absence of efficient adaptation strategies (irrigation, improved crop varieties), and their socioeconomic characteristics (the practice of self-consumption agriculture, the small size of the sown areas, the low quantity of agricultural inputs used, the poor access to agricultural extension and to credits, the multiplication of income-generating activities, and the weak school enrollment rate).
- The characterization of the adaptation strategies used shows that they are more complex than most authors who have established the typologies thought because the whole adaptation process used by sorghum farmers can be explained through a set of two actions: the agro-pastoral natural resources management by "confrontation with the climate hazards and water risks" or by "eviction of the climate hazards and water risks"; and the intense spatiotemporal diversification of the

practices (agro-pastoral natural resources management, income generating activities).

- Insofar, as the farmers are very vulnerable to the climate change, it seems given their poor socioeconomic conditions that a real improvement in their resilience depends absolutely on a real and deep improvement of these socioeconomic conditions.

---

## References

- Agossou DSM, Tossou CR, Vissoh VP, Agbossou KE (2012) Perception des perturbations climatiques, savoirs locaux et stratégies d'adaptation des producteurs agricoles béninois. *Afr Crop Sci J* 20(2):565–588
- Arodokoun UA (2011) Socioeconomic impact of the use of NICTs in adaptation strategies to climate change in rural areas: the case of cotton farmers in Center-Benin. Thesis for the Diploma of Agricultural Engineer, University of Abomey-Calavi, Abomey
- Batterbury SPJ, Forsyth T (1999) Fighting back: human adaptations in marginal environments. *Environment* 41(11):25–29
- Batterbury SPJ, Mortimore MJ (2013) Adapting to drought in the west African Sahel. In: Boultner S, Palutikov J, Karoly D, Guitart D (eds) Symposium on natural disasters and adaptation to climate change. Cambridge University Press, Cambridge
- Blanc E (2012) The impact of climate change on crop yields in sub-Saharan Africa. *Am J Clim Chang* 1:1–13
- Borton J, Nicholds N (1994) Drought and Famine. London, England: FAO
- CEDC (2010) Regional master plan for land management and use planning. Technical report. MINPLADAT, Yaoundé
- Chédé F (2012) Vulnérabilité et stratégies d'adaptation au changement climatique des paysans du Département des Collines au Bénin: cas de la Commune de Savè. Mémoire de fin d'études pour l'obtention du diplôme de Mastère en Changement climatique et développement durable. Centre Regional AGRHYMET de Niamey, Niger
- Diarra A (2008) Adaptation of Sahelian agriculture to climate change: an approach using stochastic modeling. Results of research presented at meetings of the International Institute for Water and Environment Engineering, Ouagadougou
- Dingkuhn M (2009) Adaptation des plantes cultivées au changement climatique. In: Caron P (ed) Changement climatique et agriculture: l'environnement et la sécurité alimentaire en jeu. CIRAD, Paris
- Fabre C (2010) The adaptation of food farmers in Senegal to climate change: the case of the rural community of Sessène, Thiès region. Master thesis in Geography, University of Montreal, Montreal
- FAO (2009) Food production: the determining role of water. Food and Agriculture Organization of the United Nations (FAO), Rome
- FAO, NDMC (2008) A review of drought occurrence and monitoring and planning activities in the Near East Region. FAO, Rome
- Gnanglé PC, Egah J, Baco MN, Gbemavo CDSJ, Kakai RG, Sokpon N (2012) Perceptions locales du changement climatique et mesures d'adaptation dans la gestion des parcs à karité au Nord-Benin. *Int J Biol Chem Sci* 6(1):136–149
- IPCC (2014) Climate change 2014 Synthesis report: headline statements from the summary for policymakers. Technical report. IPCC, Geneva
- Jouve P (2010) Practices and strategies for adapting farmers to climatic hazards in sub-Saharan Africa. *Grain de sel* 49:15–16
- L'Hôte Y (2000) Climatology. In: Seignobos C, Iyébi-Mandjeck O (eds) Atlas of the province of far North Cameroon (Plate 2). IRD, Paris

- Leary N, Kulkarni J, Seipt C (2007) Assessments of impacts and adaptation to climate change: summary of the final report of the AIACC project. Technical report. START, Washington, DC
- Mortimore MJ, Adams WM (2000) Farmer adaptation, change and crisis in the Sahel. *Glob Environ Chang* 11:49–57
- Ngigi NS (2009) Climate change adaptation strategies: water resources management options for smallholder farming systems in sub-Saharan Africa. Synthesis report. MDG Centre for East and Southern Africa, Nairobi
- Nhemachena C, Hassan R (2007) Micro-level analysis of farmers' adaptation to climate change in southern Africa. IFPRI discussion paper 00714. IFPRI, Washington, DC
- OECD (2010) Gestion durable des ressources en eau dans le secteur agricole. OCDE, Paris
- Sissoko K, Van Keulen H, Verhagen J, Tekken V, Battaglini A (2010) Agriculture, livelihoods and climate change in the West African Sahel. *Reg Environ Change* 3:25–37
- Yesuf M, Di Falco S, Deressa T, Ringler C, Kohlin G (2008) The impact of climate change and adaptation on food production in low-income countries: evidence from the Nile Basin (Ethiopia). IFPRI discussion paper 00828. IFPRI, Addis Ababa

**Open Access** This chapter is licensed under the terms of the Creative Commons Attribution 4.0 International License (<http://creativecommons.org/licenses/by/4.0/>), which permits use, sharing, adaptation, distribution and reproduction in any medium or format, as long as you give appropriate credit to the original author(s) and the source, provide a link to the Creative Commons license and indicate if changes were made.

The images or other third party material in this chapter are included in the chapter's Creative Commons license, unless indicated otherwise in a credit line to the material. If material is not included in the chapter's Creative Commons license and your intended use is not permitted by statutory regulation or exceeds the permitted use, you will need to obtain permission directly from the copyright holder.



# Attaining Food Security in the Wake of Climatic Risks: Lessons from the Delta State of Nigeria

## 9

Eromose E. Ebhuoma

### Contents

Introduction .....	168
Research Methodology .....	169
Findings .....	171
Livelihood Vulnerability to Climatic Risks .....	171
Assets and Food Production Nexus .....	172
Households Still Living Below the Global Poverty Line .....	174
Discussion .....	176
Final Remarks .....	177
References .....	178

### Abstract

Climate variability and change have undermined the poor rural households' ability in sub-Saharan Africa (SSA) to engage in food production effectively – which comprises their primary source of livelihood – partly because it is predominantly rain-fed. Notwithstanding, the rural poor are not docile victims to climatic risks. They actively seek innovative ways to utilize their bundle of assets to reduce the negative effects of climatic risks to ensure household food security. Bundle of assets comprise the financial, human, physical, social, and natural assets owned by, or easily accessible to, an individual. Drawing on primary data obtained qualitatively in the Delta State of Nigeria, this chapter analyzes

---

This chapter was previously published non-open access with exclusive rights reserved by the Publisher. It has been changed retrospectively to open access under a CC BY 4.0 license and the copyright holder is “The Author(s)”. For further details, please see the license information at the end of the chapter.

---

E. E. Ebhuoma (✉)

College of Agriculture and Environmental Sciences, Department of Environmental Sciences,  
University of South Africa (UNISA), Johannesburg, South Africa  
e-mail: [ebhuoe@unisa.ac.za](mailto:ebhuoe@unisa.ac.za)

how Indigenous farmers utilize their bundle of assets to grow their food in the face of a rapidly changing climate. The results indicate that human and social assets played crucial roles in facilitating household food security. Also, social assets facilitated the procurement of other assets necessary to ensure continuity in food production, albeit farmers continue to live under the global poverty line. This chapter critically discusses the implications of these findings in relation to the attainment of both the first and second Sustainable Development Goals (no poverty and zero hunger) by 2030 in the Delta State.

---

**Keywords**

Assets · Climate change · Adaptation · Food security · Indigenous farmers; Nigeria

---

**Introduction**

Climate variability and change have adversely affected various sectors of the global economy including health (Ebhuoma and Gebreslasie 2016), transportation (Jaroszowski et al. 2010), and tourism (Fitchett et al. 2017). However, no sector has been severely affected like agriculture, especially in the developing world (Intergovernmental Panel on Climate Change (IPCC) 2014). This is primary because the agricultural practices embarked upon by poor rural households are extensively dependent on rainfall (Conway and Schipper 2011). Consequently, the slightest deviation of weather patterns from the normal can subject most of the rural poor in developing countries to excruciating poverty and misery due to their inability to obtain their livelihood from food production (IPCC 2014). Furthermore, the vulnerability of the rural poor to climatic risks is exacerbated by weak institutions and agricultural policies, deficiency of social safety nets, inability to purchase farm insurance, and low levels of education (Perez et al. 2015).

In Nigeria, for example, agriculture contributes about 20% to its gross domestic product (GDP), making it next in line to the country's mainstay after crude oil (National Bureau of Statistics (NBS) 2014). In the last two decades, however, climate variability and change have wreaked havoc in various farming communities, especially in the Delta State where 90% of rural households are actively engaged in food production (Ifeanyi-obi et al. 2012). Climatic risks have become a huge cause for concern among the rural poor due to growing uncertainty regarding anticipated food productivity and outputs (Mavhura et al. 2013; Nelson et al. 2014). Despite the increased climatic risks that the rural poor in the Delta State and other parts of sub-Saharan Africa (SSA) are besieged by, they are not docile victims to these threats.

The poor, as Moser (2011) argue, are actively and consistently seeking innovative ways to utilize, modify, and adapt their bundle of assets or capital to reduce the negative effects of climatic risks on their livelihood. Bundle of assets comprises the financial, human, physical, social, and natural assets (Table 1) owned by or easily accessible to an individual. The focus on assets is crucial to facilitating the



**Table 1** Definition of bundle of assets

Asset or capital	Definition
Physical	This includes equipment, infrastructures such as road networks, and other productive resources owned by individuals, households, communities, or the country itself
Financial	This refers to financial resources available and easily accessible to individuals, which includes loan, access to credits and savings in a bank or any other financial institutions
Human	This refers to the level of education, skills, health status, and nutrition of individuals. Labor is closely associated with human capital investments. Health statuses of individuals impact either positively or negatively on their ability to work, while skill and level of education is crucial because it influences individuals return from labor
Social	This refers to the norms, rules, obligations, mutuality, and trust embedded in social relations, social structures, and societies' institutional disposition
Natural	This refers to the atmosphere, land, minerals, forests, water, and wetlands. For the rural poor, land is an essential asset.

Sources: Bebbington (1999); Moser and Satterthwaite (2008); Moser (2011)

identification of entry points to inject tailored policy interventions that are necessary to build and fortify the adaptive capacity and resilience of the rural poor (Moser 2011; Moser and Stein 2011). As documented by Moser (2011), individuals are not docile victims but possess resources that they can draw upon in times of crisis. Thus, identifying and strengthening these resources is crucial for the poor to be able to hold their own in times of crisis such as climate variability and change by deploying their available resources to ensure food security.

In the wake of a rapidly changing climate, the injection of tailored policy interventions is desperately needed to scale up food production in SSA and facilitate the actualization of Sustainable Development Goals (SDGs) 1 and 2 (no poverty and zero hunger) by 2030. Against this background, this chapter analyzes the ways in which Indigenous farmers in Igbide, Uzere, and Olomoro communities in the Delta State of Nigeria utilize their bundle of assets to grow their food in the face of a rapidly changing climate. Indigenous, in this context, refers to people that possess a peculiar culture and knowledge distinct to their community that have been examined with real-life scenarios (Ebhuoma 2020).

---

## Research Methodology

The chapter is based on primary data obtained in Olomoro, Igbide, and Uzere communities situated in *Isoko* south local government area (ISLGA) of the Delta State in Nigeria (Fig. 1). The mean annual rainfall in the Delta State is between 2500 to 3000 mm (Adejuwon 2011). Both Igbide and Uzere are low-lying, while Olomoro comprises both high- and low-lying areas. Due to annual heavy rainfall events, the low-lying farmlands are submerged from June to the last week in October.



**Fig. 1** Map of the study areas. (Source: Cartographic Unit, Wits University, South Africa (2016))

Omohode’s (2012) documentation, following the 2012 flood disaster that severely affected most States in Nigeria, influenced the choice of these communities. He highlighted that most low-lying communities in ISLGA were completely submerged, making the area resemble emergency oceans when viewed from a distance. Thus, unpacking the ways in which Indigenous farmers in these communities engage with their bundle of assets will provide valuable insights regarding how vulnerable people grow their food in the face of climatic risks.

The communities are homogeneous in nature. For instance, *Isoko*, an Indigenous language, is the local dialect spoken. Also, small-scale farming is the major economic driver of these three communities, with the women at the helm of the practice. While some men assist their wives to produce food, they are mostly involved in fishing. In terms of food production, cassava and groundnut are the predominant staples cultivated annually. Cassava makes up approximately 65% of the total caloric intake in each community. Other cultivated crops include cocoyam, potato, pepper,

and plantain. With the exception of cassava which requires a minimum of 6 months to reach maturity, the other crops can be harvested 3 months after planting.

Focus group discussions (FGDs) and semi-structured interviews were used to obtain primary data. Thirty-five FGDs and four one-to-one, semi-structured interviews (two in Olomoro, one in Igbide and Uzere) were conducted between June and October 2015. Of the 35 focus groups, 24 were made up of female respondents; five comprised male respondents, while six were made of both male and female respondents. Respondents in each FGD varied between 3 and 12 respondents aged between 20 and 85.

Respondents were identified using purposive sampling based on age, gender, those who have been farming in the study areas for a minimum of 10 years, those whose household assets and livelihoods were severely affected by the 2012 flood disaster, and those that grow their food on low-lying farmlands. Key informants who have lived in each community for over 40 years and an agricultural extension worker facilitated the recruitment of eligible respondents. Primary data retrieved were analyzed using the thematic analysis technique.

---

## Findings

### Livelihood Vulnerability to Climatic Risks

Respondents pinpointed heavy rainfall events – which resulted in seasonal flooding of low-lying farmlands annually – as the worst weather conditions that undermined effective food production through farmers’ inability to maximize their natural capital. In this regard, a respondent from Uzere, in his 80s, stated:

We are constrained to practice seasonal planting due to flooding which must occur on our farmland annually. Consequently, we must harvest all our cultivated cassava before our farmland gets inundated. This usually worsens food insecurity in times of poor harvest. ... This is the advantage farmers in neighboring communities who cultivate on high ground have over us. They do not lack *garri* (processed cassava) throughout the year.

Seasonal flooding restricts farming for 8 months annually, which has implications for the amount of food farmers are able to produce annually. The second weather conditions that adversely impacted food production are rising temperatures, especially between February and April. On the one hand, respondents aged 40 years and below revealed that the weather has become warmer in the last decade. On the other hand, the elderly respondents (50 years and above) argued that the rise in temperature began in the early 1980s. Both groups unanimously acknowledged that in the last 5 years, temperatures between February and April have become abnormally high in the afternoons. This has undermined their ability to work effectively on their farmlands. From the respondents’ viewpoint, the adverse effects of the rising temperature are evident in groundnut production as they now harvest empty pods more frequently than in previous times. A respondent from Igbide, in her 50s, asserted:

The sunlight during the months of February and March is really terrible and planting during those months is very difficult. Groundnut is the crop that is seriously affected because it does not require intense sunlight for optimal productivity.

Approximately two-thirds of the respondents stated that the change in weather conditions is due to God's making and supernatural forces. When probed about the role of humans in contributing to climate change, most debunked the claim. To concretize this viewpoint, female respondents in a FGD in Igbide unanimously agreed that *the change in weather, humans have nothing to do with it; it is solely the making of God*. However, the youths attributed the vagaries of weather to the increased rate of deforestation carried out by farmers to obtain firewood. Also, few elderly respondents revealed that the rising temperatures are due to continuous gas flaring activities by Shell's crude oil exploration activities for over 40 years. These three communities have about 62 oil wells that Shell drilled oil from before selling all its oil wells in these communities to the Integrated Data Services Limited (IDSL), a subsidiary of Nigerian national petroleum corporation (NNPC), in 2014. In this light, a male respondent from Uzere, in his 50s, commented:

This community is particularly known for farming. But since the early 1980s, the quality of both cassava and groundnut produced has reduced significantly. This is due to Shell's oil exploration activities. Most of the youths now engage in off-farm activities because farming can no longer foot their bills.

Most elderly respondents attributed the poor starch content of the *garri* (processed cassava) they produce to crude oil exploration activities. They lamented that the oil exploration had compromised their soil's nutrients, which in turn has affected the nutritional value of the *garri* produced, especially when compared to the produce harvested in the 1980s. However, only a few respondents highlighted farmers' inability to engage in bush fallowing, due to increased demand for land stemming from sporadic population growth, as an added factor that has facilitated the reduction in quality of food produced.

## **Assets and Food Production Nexus**

Due to the annual seasonal floods, farmers employ their human capital to produce cassava on their low-lying farmland through an Indigenous strategy referred to as *elelage* (follow the water). The other cultivated crops – cocoyam, potato, pepper, and plantain – are produced using the early rains, which usually begins between February and March and last till the end of May. The water strategy commences as soon as the floodwater starts to recede the farmland, usually in November. The farmers' plant their cassava stems on the part of the soil that is visible and moist. They replicate this process until the floodwaters have completely dried up from their farmland. The planting process usually ends between the second and third week in December.

The following year, between June and August, when the rain is heavy and continues to fall consistently, they start harvesting their produce. The decision regarding where to commence harvesting is hinged on their human capital informed by their Indigenous knowledge, as they know the precise portion of their farmland that will be submerged at the earliest. Thus, they do not harvest all their farm produce simultaneously. The crop closest to where the inundation will commence are harvested first. The reason for not harvesting all the produce at the same time is because the longer cassava remains in the soil, the bulkier they get. Also, labor shortage is another factor that contributes to adopting this harvesting strategy. Thereafter, usually within a week, they would return – pending on the consistency of rainfall – to their farmland to employ a similar process to harvest the other produce. After harvesting all their produce, they preserve the cassava stems on their inundated farmland by constructing temporary structures to use them for food production in the next planting season (Fig. 2).

To ensure they have *garri* to eat all year round, they utilize their human capital to process the harvested cassava as well as store it properly. Respondents explained that after the necessary procedures have been implemented, which entail peeling, soaking the cassava in water for several hours, drying the soaked tubers and blending into powdered form, it is fried with little palm oil to an overly dried state. After cooling down, the *garri* is preserved in airtight sack bags. Thereafter, a wooden structure is constructed and the sack bags placed on top of it. The fundamental reason for suspending the sack bags from the ground is to prevent the *garri* from going bad through mold formation.



**Fig. 2** Indigenous technique used to preserve cassava stem on low-lying farmland. (Photograph: John Ayiko (2015))

It is noteworthy to mention that some farmers rent farmland, a natural capital, to grow their food. Because most farmers lack financial capital during the planting season, social capital plays a vital role in this regard only for trustworthy individuals. As a respondent from Uzere, in her 40s, highlighted:

Most farmers lack finances during the planting season. Consequently, only trustworthy individuals are privileged to get farm plots leased to them without having to pay the agreed sum upfront. Often times, they pay the landowners after harvesting and traded some of the produce.

Also, some farmers – due to a shortage of household labor and lack of capacity to hire laborers – drew on their social capital to acquire human capital to facilitate the harvesting of farm produce before the occurrence of the seasonal flooding. Specifically, some farmers depend on neighbors, relatives, and friends to accelerate the harvesting process to avert the possibility of some of the produced cassava from decaying. Furthermore, social capital catalyzed the procurement of financial capital. This is particularly useful as most farmers have been unable to benefit from several loan schemes afforded by the Delta State government against the backdrop of the farm loans being disbursed consistently for over 10 years (United Nations Development Program (UNDP) 2014). Some highlighted that they only hear of farm loans after the application process had closed, a state of affairs which was largely attributed to nepotism.

Although microfinance banks (MFB) in the Delta State have been given directives to provide the rural poor with farm loans, the inability to provide collateral matching the value of the loan sought after or a guarantor with valuable assets has hampered farmers' ability to secure such loans. As respondents in a female-only FGD in Olomoro bemoaned:

Loans exist that could reduce some of the challenges we undergo as farmers, but due to the fact that there is nobody to stand as a guarantor [lack of social capital], they have not been able to harness such opportunities.

Since farmers' annual earnings from food production (between 137 USD to 219 USD) are inadequate to secure their livelihood objectives, they utilize their social capital to temper the financial drought. This is achieved by some community members coming together to form a small group where the prior agreed monetary contributions are made weekly to a trustworthy individual. At the end of each month, the total sum is given to a group member, hinged on prearrangement. This scheme, referred to as *Osusu*, is useful in ensuring that farmers can purchase items necessary for food production.

## **Households Still Living Below the Global Poverty Line**

Despite farmers' skillful utilization of their meager bundle of assets at their disposal to ensure continuity in food production, the majority still live under the global

poverty line of less than \$US 1.90 a day (Livingston et al. 2011). A fundamental reason for this is due to the low financial gains made from the sale of *garri* underpinned by its inferior quality when compared with those produced in neighboring communities' void of oil exploration activities. Thus, they are "forced" to market their produce at a much-reduced price.

Another factor that impeded farmers from transcending living above the global poverty line is due to the exorbitant interest rate money is borrowed from unregulated bodies such as informal meeting groups and money lenders. Respondents highlighted that not knowing influential people, underpinned by lack of social capital, to act as guarantors to co-sign the credit agreement to access farm loans from MFB is a pull factor toward securing loans from unregulated sources. As some respondents explain, this is prevalent during the planting season as farmers often run out of money having addressed other pressing issues such as paying for both children's tuition fees and levies attached to social responsibility. Thus, farmers are left with no feasible alternative but to obtain loans from "financial predators" as their requirements are less demanding. While the loan obtained enables farmers to produce their food, it proved counterproductive in terms of evading the poverty maze. For example, if a farmer borrows 50 USD for 6 months, the farmer is required to refund the loan with a whopping 40% interest. This is testament to the fact that the drive to become food secure pushes farmers to do anything within their powers to achieve the objective, regardless of the long-term consequences.

The financial predators are well knowledgeable on the importance of farm loans in ensuring household food security. As a result, they are unwilling to water down their terms and conditions. In this regard, a farmer from Igbide, in his 50s, explained:

Without loans, some farmers cannot grow food. After these farmers secure loan from non-government bodies, grow their food and sold some of the produce to refund the loan, most of the time, they are left with little or nothing for the next planting season. The only choice they have is to go back to secure loans from the group that lend them money previously. This is the survival tactic of some farmers in this community.

In fact, the inability to access loan is a catalyst that has made some farmers to engage in off-farm activities. Another factor that compromised effective food production was the lack of physical capital, especially for farmers with access to large hectares of land enough to engage in commercial farming. For example, farmers' inability to access farm machinery dampened their fight to transcend the boundaries of a subsistence farmer. A male respondent in Uzere stated that while the Delta State government usually provides farm equipment for farmers, "it never gets to them." Instead, the equipment is "always hijacked" by influential politicians and close associates of key politicians in the Delta State. In addition, the unavailability of rice milling machines has prevented farmers from producing rice. Few elderly respondents (50 years and above) in Igbide revealed:

In the 1960s, they were actively involved in rice production because of the swampy nature of their farmlands, and rice milling machines provided by the government. But since the 1970s till date, no provision has been made to provide rice milling machines for farmers. As a result, rice cultivation has been abandoned.

Finally, the farmers lamented bitterly that despite the enormous contributions their communities have made to the nation's foreign revenue for over four decades, their communities have remained shockingly underdeveloped. The lack of good road networks within each community, for example, erodes the financial capital of some farmers, albeit insidiously. To illustrate, during the rainy seasons, it can be challenging for motorists to navigate their way through their community due to countless potholes. This makes accessibility to markets where they have to sell some of their farm produce an exasperating venture.

---

## Discussion

The adverse effects of climatic risks are palpable in Igbide, Uzere, and Olomoro communities in the Delta State of Nigeria. They have manifested in the form of heavy rainfall events (Ifeanyi-obi et al. 2012), which leads to seasonal flooding of low-lying farmlands, and rising temperatures (Ike and Ezeafulukwe 2015). While these climatic variables have undermined food production, oil exploration activities have aggravated farmers' woes. By significantly degrading soil's nutrients, oil exploration activities have adversely compromised the quality of food produced. This assertion is corroborated by research findings that have also emerged from the Delta State (Ererobe 2009; Elum et al. 2016). Nonetheless, the findings can be disaggregated into two key points.

First, farmers' perception of climate change is underpinned by religious framing. Similar findings have been recorded in Botswana (Spear et al. 2019), Mali (Bell 2014), Nigeria (Jellason et al. 2020), South Africa (Okem and Bracking 2019), and Zimbabwe (Moyo et al. 2012), respectively. Attributing the cause of climate change to oil exploration activities, God and other supernatural forces as well as disentangling their lifestyle activity – deforestation – as a contributing factor seems the logical way for people to continue with the state of affairs without any ill feelings. Accepting how their lifestyle choices may be contributing to climate change, no matter how insignificant it may seem in comparison to gas flaring, for example, will doubtlessly require behavioral changes. In contrast to studies that show that people highly vulnerable to climate change may be more willing to adopt behavioral changes (Akerlof et al. 2013; Azadi et al. 2019), this may not be feasible for farmers in the Delta State due to their quest to obtain their livelihood by any means necessary.

For instance, to rely on kerosene or gas-fueled stoves for cooking may have substantial financial implications in comparison to firewood. In this light, therefore, the need to sensitize farmers on how their actions are contributing to climate change, including the possible future implications for household food security, is essential. This is primarily because rural households in SSA are expected to be adversely affected by the impacts of future climate change (IPCC 2014). Also, it is necessary to involve religious clergies as key stakeholders in the discourse around climate change mitigation as their beliefs and values have the potential to influence the behaviors of their congregation.



Second, farmers have carved out unique strategies to maximize their meager asset portfolios to produce food despite the increasing threats from climatic risks. The systematic ways in which farmers utilize their human capital to grow food on their low-lying farmlands indicate that farmers are not helpless victims to climatic risks. This is corroborated by findings in Bangladesh (Al Mamun and Al Pavel 2014), Botswana (Motsumi et al. 2012), and Zimbabwe (Mavhura et al. 2013). With the right support and interventions such as providing easy access to loans, machinery, and good road networks, the likelihood that farmers will successfully transcend living above the global poverty line is extremely high. As several studies show (Kochar 1997; Akoijam 2012; Ibrahim and Aliero 2012; Assogba et al. 2017), easy access to government loans remain a major challenge for rural farmers in developing countries. It is documented that the flourishing of exploitative money lenders is due to low priority given to rural credit (Akoijam 2012). Thus, to ensure farmers access farm loans, robust broadcasting of any program through mediums utilized by households to receive vital information are crucial. Otherwise, the persistent dependence on financial predators will continue to flourish, to the detriment of farmers in the Delta State achieving the first SDG.

It should be emphasized that the skillful utilization of social capital to acquire human capital (assistance with cassava harvesting), financial capital (*Osusu*), and natural capital (not paying the rental before cultivating on farmland) indicates that climate adaptation interventions that may cause fragmentation of households should be avoided. For example, suppose the government wants to provide farmlands on higher grounds to farmers to ensure they can produce food all year round. In that case, farmers in the same community should be given land close to one another. This is crucial for the strengthening of social capital, which is essential to facilitating household food security and ensuring that the country is on the trajectory toward achieving the first (no poverty) and second (zero hunger) SDGs by 2030. As Joshi and Aoki (2014) argue, strong social networks influence household's ability to recover from a disaster.

---

## Final Remarks

Climatic risks are making life difficult for the farmers cultivating on the low-lying farmlands in Olomoro, Uzere, and Igbide communities. In responding to these threats, Indigenous farmers skillfully employ their limited bundle of assets to continue producing their food. Specifically, this chapter illustrated how human capital plays a pivotal role in ensuring the production of cassava in the low-lying farmlands, which experiences seasonal flooding annually, through an Indigenous strategy referred to as *eleleme* (follow the water). Also, social capital is a crucial asset in farmers' portfolio through its ability to facilitating the procurement of financial capital through a local scheme called *Osusu*. Further, it enabled the acquisition of natural capital by allowing trustworthy individuals to renting farmlands and only paying the fee after harvesting and selling some of the produce. Since social capital is overwhelmingly fundamental to the achievement of food security,

any scheme meant to assist farmers to adapt more effectively to climatic risks to produce more food must ensure it creates an avenue for strengthening ties among farmers.

This chapter also finds that despite farmers' ability to attain household food security every year, they still live below the global poverty line. A key factor fuelling this state of affairs is primarily due to the inaccessibility of government loans. Consequently, financially strapped farmers are constrained to secure loans from unregulated sources. While it provides a leeway to continue in food production, it is counterproductive due to the high-interest rates attached to the loans. Perhaps, easing the loan acquisition process from MFB may successfully combat this menace. Otherwise, farmers will be unable to weave their way out of poverty. To conclude, until interventions are geared toward ensuring the protection, strengthening, and making the acquisition of assets that play a fundamental role in food production, chances of successfully achieving the first and second SDGs will be slim.

---

## References

- Adejuwon JO (2011) A spectral analysis of rainfall in Edo and Delta states (formerly mid-western region), Nigeria. *Int J Climatol* 31:2365–2370
- Akerlof K, Maibach EW, Fitzgerald D, Cedenro AY, Neuman A (2013) Do people 'personally experience' global warming, and if so how, and does it matter? *Glob Environ Chang* 23(1):81–91
- Akoijam SLS (2012) Rural credit: a source of sustainable livelihood of rural India. *Int J Soc Econ* 40:83–97
- Al Mamun MA, Al Pavel MA (2014) Climate change adaptation strategies through indigenous knowledge system: aspect on agro-crop production in the flood prone areas of Bangladesh. *Asian J Agric Rural Dev* 4(1):42–58
- Assogba PN, Kokoye SEH, Yegbemey RN, Djenontin AJ (2017) Determinants of credit access by smallholder farmers in North-East Benin. *J Dev Agric Econ* 9(8):210–216
- Azadi Y, Yazdanpanah M, Mahmoudi H (2019) Understanding smallholder farmers' adaptation behaviours through climate change beliefs, risk perception, trust, and psychological distance: evidence from wheat growers in Iran. *J Environ Manag* 250:109456. <https://doi.org/10.1016/j.jenvman.2019.109456>
- Bebbington A (1999) Capitals and capabilities: a framework for analyzing peasant viability, rural livelihoods and poverty. *World Dev* 27:2021–2044
- Bell D (2014) Understanding a "broken world": Islam, ritual, and climate change in Mali, West Africa. *J Study Relig Nat Cult* 8(3):287–306
- Conway D, Schipper ELF (2011) Adaptation to climate change in Africa: challenges and opportunities identified from Ethiopia. *Glob Environ Chang* 21:227–237
- Ebhuoma E (2020) A framework for integrating scientific forecasts with indigenous systems of weather forecasting in southern Nigeria. *Dev Pract* 30:472–484
- Ebhuoma O, Gebreslasie M (2016) Remote sensing-driven climatic/environmental variables for modelling malaria transmission in sub-Saharan Africa. *Int J Environ Res Public Health* 13(6):584. <https://doi.org/10.3390/ijerph13060584>
- Elum ZA, Mopipi K, Henri-Ukoha A (2016) Oil exploitation and its socioeconomic effects on the Niger Delta region of Nigeria. *Environ Sci Pollut Res* 23:12880–12889
- Ererobe M (2009) FG, multinationals and Isoko nation. <https://www.vanguardngr.com/2009/08/fg-multinationals-and-isoko-nation/>. Accessed 3 Apr 2020
- Fitchett JM, Robinson D, Hoogendoorn G (2017) Climate suitability for tourism in South Africa. *J Sustain Tour* 25(6):851–867

- Ibrahim SS, Aliero HM (2012) An analysis of farmers' access to formal credit in the rural areas of Nigeria. *Afr J Agric Res* 7:6249–6253
- Ifeanyi-obi C, Etuk U, Jike-wai O (2012) Climate change, effects and adaptation strategies: implication for agricultural extension system in Nigeria. *Greener J Agric Sci* 2:53–60
- Ike PC, Ezeafulukwe LC (2015) Analysis of coping strategies adopted against climate change by small scale farmers in Delta state, Nigeria. *J Nat Sci Res* 5:15–24
- Intergovernmental Panel on Climate Change (IPCC) (2014) Africa. Intergovernmental Panel on Climate Change. [https://www.ipcc.ch/pdf/assessment-report/ar5/wg2/WGIIAR5-Chap22\\_FINAL.pdf](https://www.ipcc.ch/pdf/assessment-report/ar5/wg2/WGIIAR5-Chap22_FINAL.pdf). Accessed 25 Sept 2020
- Jaroszowski D, Chapman L, Petts J (2010) Assessing the potential impact of climate change on transportation: the need for an interdisciplinary approach. *J Transp Geogr* 18:331–335
- Jellason NP, Conway JS, Baines RN (2020) Exploring smallholders' cultural beliefs and their implication for adaptation to climate change in North-Western Nigeria. *Soc Sci J*. <https://doi.org/10.1080/03623319.2020.1774720>
- Joshi A, Aoki M (2014) The role of social capital and public policy in disaster recovery: a case study of Tamil Nadu state, India. *Int J Disaster Risk Reduct* 7:100–108
- Kochar A (1997) An empirical investigation of rationing constraints in rural credit markets in India. *J Dev Econ* 53:339–371
- Livingston G, Schonberger S, Delaney S (2011) Sub-Saharan Africa: the state of smallholders in agriculture. <http://www.ifad.org/documents/10180/78d97354-8d30-466e-b75c-9406bf47779c>. Accessed 12 June 2015
- Mavhura E, Manyena SB, Collins AE, Manatsa D (2013) Indigenous knowledge, coping strategies and resilience to floods in Muzarabani, Zimbabwe. *Int J Disaster Risk Reduc* 5:38–48
- Moser C (2011) A conceptual and operational framework for pro-poor asset adaptation to urban climate change. <http://siteresources.worldbank.org/INTURBANDEVELOPMENT/Resources/336387-1256566800920/6505269-1268260567624/Moser.pdf>. Accessed 25 Sept 2020
- Moser C, Satterthwaite D (2008) Towards pro-poor adaptation to climate change in the urban centers of low- and middle-income countries. <http://pubs.iied.org/pdfs/10564IIED.pdf>. Accessed 25 Sept 2020
- Moser C, Stein A (2011) Implementing urban participatory climate change adaptation appraisals: a methodological guideline. *Environ Urban* 23:463–485
- Motsumi S, Magole L, Kgathi D (2012) Indigenous knowledge and land use policy: implications for livelihoods of flood recession farming communities in the Okavango Delta, Botswana. *Phys Chem Earth A/B/C* 50–52:185–195
- Moyo M, Mvumi BM, Kunzekweguta M, Mazvimavi K, Craufurd P, Dorward P (2012) Farmer perception of climate change and variability in the semi-arid Zimbabwe in relation to climatology evidence. *Afr Crop Sci J* 20:371–333
- National Bureau of Statistics (NBS) (2014) Delta state information. <http://www.nigerianstat.gov.ng/information/details/Delta>. Accessed 22 Dec 2015
- Nelson G, Rosegrant MW, Koo J, Robertson R, Sulser T, Zhu T (2014) Climate change impact on agriculture and costs of adaptation. <http://www.ifpri.org/sites/default/files/publications/pr21.pdf>. Accessed 11 July 2015
- Okem AE, Bracking S (2019) The poverty reduction co-benefits of climate change-related projects in eThekweni Municipality, South Africa. In: Cobbinah P, Addaney M (eds) *The geography of climate change adaptation in urban Africa*. Palgrave Macmillan, Cham. [https://doi.org/10.1007/978-3-030-04873-0\\_10](https://doi.org/10.1007/978-3-030-04873-0_10)
- Omohode R (2012) How massive flood swept away 50 Isoko communities, rendered thousands homeless. [http://www.urhobotimes.com/individual\\_news.php?itemid=820](http://www.urhobotimes.com/individual_news.php?itemid=820). Accessed 6 Apr 2015
- Perez C, Jones EM, Kristjanson P, Cramer L, Thornton PK, Förch W, Barahona C (2015) How resilient are farming households and communities to a changing climate in Africa? A gender-based perspective. *Glob Environ Chang* 34:95–107
- Spear D, Selato JC, Mosime B, Nyamwanza AM (2019) Harnessing diverse knowledge and belief systems to adapt to climate change in semi-arid rural Africa. *Clim Serv* 14:31–36
- United Nations Development Programme (UNDP) (2014) Delta State development performance: agricultural sector report, 1991–2014. [http://www.undp.org/content/dam/nigeria/docs/InclusiveGrwth/UNDP\\_NG\\_DeltaState\\_Agric\\_2015.pdf](http://www.undp.org/content/dam/nigeria/docs/InclusiveGrwth/UNDP_NG_DeltaState_Agric_2015.pdf). Accessed 15 Nov 2015

**Open Access** This chapter is licensed under the terms of the Creative Commons Attribution 4.0 International License (<http://creativecommons.org/licenses/by/4.0/>), which permits use, sharing, adaptation, distribution and reproduction in any medium or format, as long as you give appropriate credit to the original author(s) and the source, provide a link to the Creative Commons license and indicate if changes were made.

The images or other third party material in this chapter are included in the chapter's Creative Commons license, unless indicated otherwise in a credit line to the material. If material is not included in the chapter's Creative Commons license and your intended use is not permitted by statutory regulation or exceeds the permitted use, you will need to obtain permission directly from the copyright holder.





# Tied Ridges and Better Cotton Breeds for Climate Change Adaptation

# 10

R. Mandumbu, C. Nyawenze, J. T. Rugare, G. Nyamadzawo, C. Parwada, and H. Tibugari

## Contents

Introduction .....	182
Characteristics of Cotton Growing Areas in Zimbabwe .....	185
Crop Genetic Diversity and Climate Change .....	185
Status of Cotton .....	186
In-Field Moisture Harvesting .....	188
Tied Ridges .....	188
Planting Basins .....	188
Mulch Ripping .....	189

This chapter was previously published non-open access with exclusive rights reserved by the Publisher. It has been changed retrospectively to open access under a CC BY 4.0 license and the copyright holder is “The Author(s)”. For further details, please see the license information at the end of the chapter.

R. Mandumbu (✉)

Crop Science Department, Bindura University of Science Education,  
Bindura, Zimbabwe  
e-mail: [rmandumbu@gmail.com](mailto:rmandumbu@gmail.com)

C. Nyawenze

Cotton Company of Zimbabwe, Harare, Zimbabwe

J. T. Rugare

Department of Crop Science, University of Zimbabwe, Harare, Zimbabwe

G. Nyamadzawo

Department of Environmental Science, Bindura University of Science Education,  
Bindura, Zimbabwe

C. Parwada

Department of Horticulture, Women’s University in Africa, Harare, Zimbabwe

H. Tibugari

Department of Plant and Soil Sciences, Gwanda State University, Gwanda, Zimbabwe

© The Author(s) 2021

W. Leal Filho et al. (eds.), *African Handbook of Climate Change Adaptation*,  
[https://doi.org/10.1007/978-3-030-45106-6\\_23](https://doi.org/10.1007/978-3-030-45106-6_23)

181

---

Cotton Production Under Climate Change .....	189
Effects of Water Harvesting on Soil Moisture Content .....	189
References .....	193

---

## Abstract

Climate change and variability is already reducing agricultural productivity and opportunities for employment, pushing up food prices and affecting food availability and production of formerly adapted crop types. Such is the case in cotton production in Zimbabwe, where it was the only viable commercial crop in marginal areas. As a form of adaptation, there is need for African farmers to have a range of agricultural techniques as coping strategies and tactics to enable sustainable production of crops and deal with extreme events. Such techniques include water conservation and introduction of new adapted crop genetics to cope with the new environment. The emerging trends in climate change will force farmers to adopt new crops and varieties and forms of agricultural production technologies. The objective of this study is to determine the contribution of combining in-field water harvesting and early maturing cotton varieties in curbing drought in cotton in semiarid Zimbabwe. The results show that both water harvesting in form of planting basins significantly ( $P < 0.05$ ) increased boll number and branch number of cotton across all varieties. The varieties M577 and M567 out-performed the conventional varieties in early growth, branch number, and boll number. Tied contour ridges gave a significantly ( $P < 0.05$ ) higher moisture content in 0–5 cm and the 6–10 cm depth compared to conventional tillage. The new varieties displayed early phenological development. Despite the existence of rainfall gaps, the in-field water harvesting techniques captured enough moisture and prevented moisture losses through runoff which resulted successful flowering and fruiting in the short varieties compared to conventional tillage on conventional varieties. In this regard, water harvesting and early maturing varieties offer considerable hope for increasing crop production in arid and semiarid areas of Zimbabwe.

---

## Keywords

Climate change · Adaptation · Water conservation · Cotton · Semiarid

---

## Introduction

Africa is regarded as having climates that are among the most viable in the world on seasonal and decadal time scales (UNFCCC 2007). Floods and droughts can occur in the same area within months from each other. Of the total additional people at risk of hunger due to climate change, although already larger proportion, Africa may account for the majority by the 2080s (Fischer et al. 2002). The increase in erratic rainfall seasons characterized by unpredictable length of seasons, high temperatures alternating floods and dry spells, and variable rainfall amounts presents new

**Table 1** Agro-ecological regions and potential land use for Zimbabwe

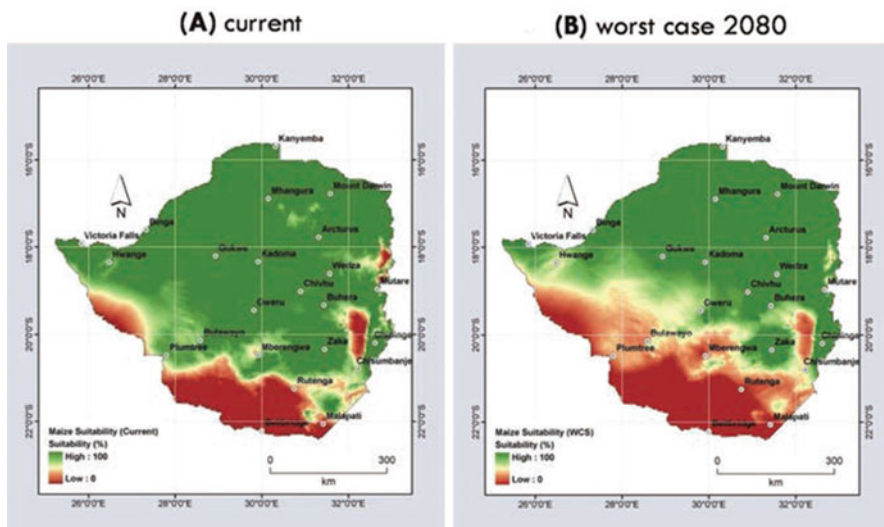
Agro-ecological zone	Area (ha)	Area as % of country	Characteristic weather	Recommended land use
<b>I</b>	703,400	1.8	High rainfall (>900 mm per annum), with some precipitation throughout the year. Low temperatures	Fruits, tea, coffee macadamia nuts, intensive livestock production
<b>II</b>	5,861,400	15.1	Moderately high (750–1000 mm per annum) rainfall confined to summer. Severe dry spells are rare	Intensive crop and/or livestock production
<b>III</b>	7,287,700	19.5	Infrequent heavy rainfall leads to moderate annual recording of about 650–800 mm. Fairly severe mid-season dry spells	Marginal for maize, tobacco, and cotton production, livestock production
<b>IV</b>	14,782,300	36.7	Fairly low total rainfall (450–650 mm per annum). Periodic seasonal droughts, severe dry spells during rainy season	Drought resistant crops such as sorghum and pearl millet, livestock production
<b>V</b>	10,441,100	26.8	Low and erratic rainfall (<450 mm per annum, <650 mm in the Zambezi valley, and <600 mm in the Sabi-Limpopo Valleys). Prolonged midterm dry spells	Too dry for successful crop production without irrigation. Marginal millet, sorghum, extensive beef ranching, game ranching

challenges to the majority of the farmers in the absence of appropriate response strategy (Zimbabwe climate change response strategy, 2017). In the 2018–2019 cropping season below normal and highly erratic and patchy rainfall was recorded for the first half of the season and most crops were stressed with most being completely written off because of prolonged dryness (FEWS Net 2019).

In Zimbabwe, over 70% of Zimbabwe's employment is directly or indirectly accounted for by agriculture. The national agricultural production largely relies on rain-fed agriculture which is one of the most vulnerable sectors to climate change and variability. Adaptation to climate change will entail adjustments and changes at every level from community to national level. Communities must build their resilience including adapting appropriate technologies while making the most of traditionally and locally generated technologies and diversifying their livelihoods to cope with the current and future stresses (Fischer et al. 2002).

Zimbabwe is generally characterized by low rainfall and more than 50% of its land area falls under region IV and V which receive rainfall lower than 650 mm per season (Table 1).

Maize planted late will not give good yields, thus making maize production a less viable activity under climate change conditions. In the low-lying areas of southern



**Fig. 1** A comparison of the maize production zones under the current and worst case scenario for the year 2080. (Source: Zimbabwe's Second Communication to the United Nations framework convention on climate change (UNFCCC))

Zimbabwe, for example, it is probable that climate change will turn the region into a non-maize-producing area, as exemplified by reduced maize production in Masvingo (Fig. 1). The projections are that by 2080 the area suitable for maize production in the south-western and central provinces of Zimbabwe will have decreased (Fig. 1).

This area, which represents 42% of the communal area, will become even more marginal for maize production. Based on site results, seasons could be 25% shorter than now.

Communities living in natural regions IV and V (which make up about 64% of the land area) are at the mercy of climatic extremes, with few livelihood options (Brazier 2015). They tend to be the most vulnerable to poverty. These regions are already feeling the impacts of climate change and will be the hardest hit in the future. Climate change will exacerbate hardship and poverty among the people of Zimbabwe. Women, children, and the disabled, especially those living in rural areas, will be the worst affected. The causes of rural poverty relate to the adverse climate and environmental conditions that disrupt agriculture, the main livelihood activity in areas where most people live. Women, children, the elderly and the disabled have been identified in several studies as being the most vulnerable to shocks. Zimbabwe's agricultural systems are already insecure as they depend mainly on seasonal rainfall. In addition, ruinous land use practices in the form of poor soil and water management, reduced biodiversity, and poor choice of crops to plant have led to degradation of the resource based on which agriculture depends. Climate change will hasten the degradation and exacerbate food insecurity, which is already



**Table 2** The impacts, sectorial vulnerabilities, and adaptive capacity to climate change

Impacts	Sectorial vulnerability	Adaptive capacity
Warming by 1.5 °C	Agricultural production severely compromised	Rainwater harvesting
Drier subtropical regions	Uncertainty on what and when to plant	Improved varieties that fit into the current seasons
Decrease in annual rainfall	Yields from rain-fed production can be halved	
Extreme events: increase in frequency and intensity of storms and droughts and floods	Net revenue could fall by 90% by 2100	

Adapted and modified from Christensen et al. (2007)

prevalent in Zimbabwe. There are likely to be shifts in the start and end of the rainy season, and the onset of the rains may be delayed by between 4 and 6 weeks. This will mean changes in planting and harvesting dates, the length of the growing season, and the types of crops that farmers are forced to adopt.

Climate change affects crop production in the following ways (Table 2).

---

## Characteristics of Cotton Growing Areas in Zimbabwe

The farms are generally small, often held under traditional tenure and are located in marginal areas which are risk prone (FAO 2012). Their challenge is to improve production of cotton under climate change. The investments in farming are low and their ability to adapt is very low. The inventions in this sector have to low cost so that adaptation levels are high hence the introduction of tied ridges and use of imported varieties for sustainable cotton production. Varieties purchase will be done by everybody prior to the onset of the season. Tied ridges are not an expensive technology to introduce to the farmers as long as they understand the merits.

---

## Crop Genetic Diversity and Climate Change

The emerging changes in climate will force farmers to adopt new varieties and crop types and forms of agricultural production technologies that can respond to new and changing stress factors. The areas that are currently the most food insecure will be worst affected and will have the greatest need for new crop varieties that are tolerant to drought high temperatures flooding salinity and other environmental extremes (FAO 2015). Diverse crop species, varieties, and cultivation practices allow crops to be grown across a wide range of environments. Sometimes better adapted varieties will need to be brought in from outside.

Traits that contribute to phenotypic plasticity (ability to cope with a wide range of environmental conditions) may be increasingly important. Such is the case with cotton in Zimbabwe where the traditional varieties were complimented by imports of new cotton seed varieties from India.

Genetic resources could contribute greatly to efforts to cope with climate change. It is likely that climate change will necessitate more international exchanges of genetic resources as countries seek to obtain well-adapted crops. There is likely going to be a greater interdependence on the use of genetic resources and that underscores the importance of international cooperation (FAO 2015).

Food-insecure people in the developing world such as Zimbabwe especially women and indigenous people are among the most vulnerable groups and usually the hardest hit. In the case of cotton, the varieties used in Zimbabwe were not of a match to the current environmental characteristics. Zimbabwe farmers continued to cultivate the varieties although they were poorly adapted to the environment. The Cotton Company of Zimbabwe imported hybrid varieties from India with the objective of improving productivity and helping farmers to cope with environmental adversities.

---

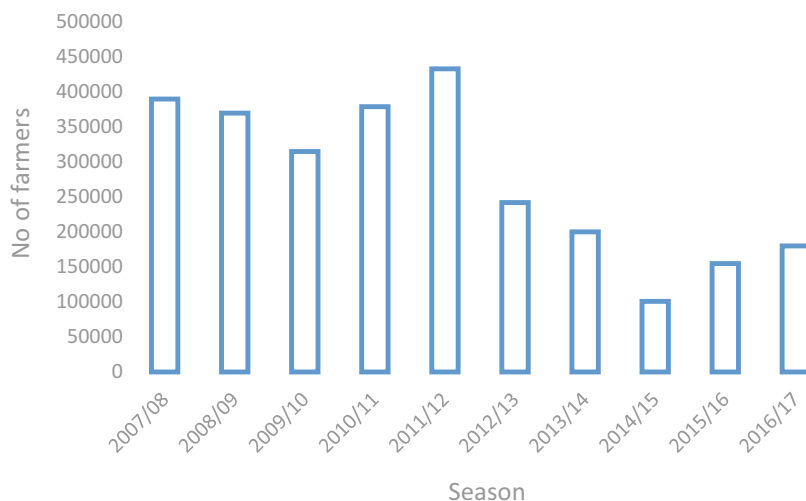
## Status of Cotton

Cotton is the second most important cash crop in Zimbabwe and is grown by thousands of smallholder farmers on average plot sizes of about 1 ha in the summer growing season (Global Agricultural Information Network 2017). The crop is strategic for poverty alleviation and is of major significance to food security for smallholder farmers in marginal areas due to its contribution to incomes and employment (Mujeyi 2013). The crop supports over one million people in marginal areas of Zimbabwe including farmers their families, farm workers, and industrial workers (Buka 2017; Mujeyi 2013). Most cotton growers have limited opportunities as these are in semiarid areas and cotton production is the only viable option.

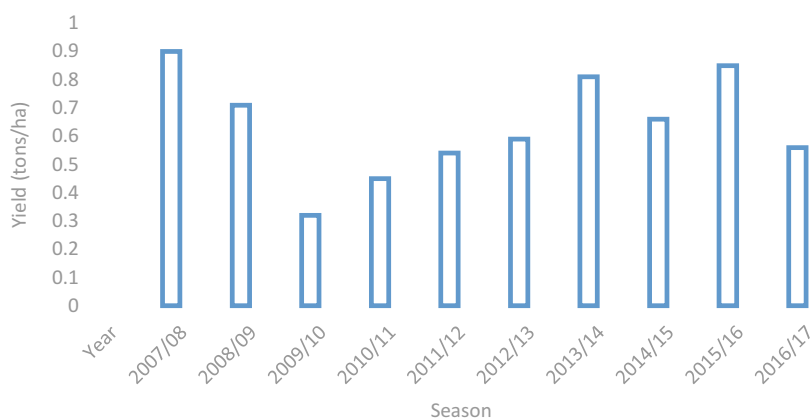
However, cotton production has been on the decrease in terms of the number of farmers producing the crop (Fig. 2).

In some years the government intervened in cotton production through free cotton inputs. Generally the trend from the number of cotton farmers to yield per hectare (Figs. 2 and 3) points to the fact that cotton production is in the decrease. This might be partly due to the low prices on the international market. The low levels of production might be partly due to old varieties which are poorly adapted to the current environmental trends as dictated by climate change. There have been no new cotton varieties over the past 25 years in Zimbabwe. This implies that the recent climate shifts experienced in most parts of the world has not been factored in Zimbabwe cotton breeding program. The government of Zimbabwe prohibited the use of genetically modified seed which might have improved cotton yields.

Climate change has brought greater uncertainty and exposure to multiple climate stress. The lives of millions of people in semiarid Zimbabwe who depended on



**Fig. 2** Number of farmers cultivating cotton from 2007/08 season to 2016/17 season in Zimbabwe



**Fig. 3** Average yield of cotton (t/ha) from 2007/08 to 2016/17

cotton for their livelihood are highly vulnerable to climate change. The local farmers have traditionally managed harsh environment by growing moisture stress-tolerant cotton. In order to improve the effectiveness of crop production in these marginal rainfall regions, cultural practices which conserve water availability to the crop are essential (Mupangwa et al. 2006).

Investing in agricultural production methods to boost farmers' resilience against weather shocks is a key strategy to reduce negative impacts. The cotton growing areas of Zimbabwe are generally rain fed and are characterized by rainfall patterns which are highly variable in amount and distribution. This has been exacerbated by

climate change. According to McHugh et al. (2007), the main limitation for increasing crop yields in rain-fed farming systems is crop water stress caused by inefficient use of rainwater. Rockstrom and Falkenmark (2000) reported that inefficient use of rainwater is often a consequence of poor rainfall partitioning resulting in low root-zone soil moisture or poor plant uptake of available moisture. Making rainfall available and its effective storage and efficient use are therefore important adaptive mechanisms and major determinants in cotton production under climate change. According to Nyamadzawo et al. (2013), climate change models have projected a decrease in rainfall in southern Africa and research has already shown the same. Therefore, the focus should be on upgrading rain-fed smallholder farming in tropical environments characterized by frequent droughts and mid-season dry spells. According to Ibraimo and Munguambe (2007), there is need for more efficient capture and use of scarce water resources in arid and semiarid areas. The optimization of rainfall management through water harvesting in sustainable and integrated production system can contribute to improve small scale farming households by upgrading rain-fed agricultural production. Research has documented substantial increases that are obtained through soil water conservation and efficient use of it by the crop, and, subsequently, the yield increases.

---

## **In-Field Moisture Harvesting**

### **Tied Ridges**

The effect of the ridges was generally higher in drier periods and more when the ridge ends were tied. Belay et al. (1998) reported that in wetter seasons, open-end ridges gave higher yields which show how important it is that soil and land management practices include means to safely dispose water from the field, should the rain exceed the retention of the soil. UNEP (1997) also confirmed that rain water harvesting involves the use of methods that increase the amount of water stored in the soil profile by trapping or holding the rain where it falls and it involves small movements of rainwater in order to concentrate it where it is required.

### **Planting Basins**

In Zimbabwe, planting basins are structures that are dug from July through October in the same positions annually and whose recommended dimensions are 15 cm length by 15 cm width and 15 cm depth (Mupangwa et al. 2006; Twomlow and Hove 2007). These basins are spaced at 90 cm by 60 cm. The basins benefit, particularly, poorer farmers with no access to draught power as they will not have delayed planting as they wait to borrow draught power from their neighbors (Mazvimavi and Twomlow 2007).

## Mulch Ripping

Ox-drawn rip lines are made from attachments fitted on the plough frame and were developed to open furrows for moisture capture. They also break superficially compacted layers (Mandumbu 2011). Mapfumo et al. (2002) explained that mulch ripping makes use of the soil on the surface to protect the soil underneath, making soil disturbance limited to the planting zones, and ripping is done to a depth of 23 cm. In Zimbabwe, rip lines that are being promoted go to a depth of 23 cm.

---

## Cotton Production Under Climate Change

Drought-tolerant cotton and in-field water harvesting are promising technologies to minimize the impacts of drought (Katengeza et al. 2019). The farmers in Zambezi valley in Zimbabwe have traditionally used two cotton varieties. Although these have over the years sufficed, they are currently failing due to recent trends on climate change. The low cotton genetic diversity and its use in traditional risk management may affect the resilience of farmers especially recently due to existing stresses which have made the environment more unpredictable (Meldrum et al. 2017). According to Thomas et al. (2015) the importance of crop genetic diversity or resilience and adaptation of farm systems to climate change is highlighted in many studies.

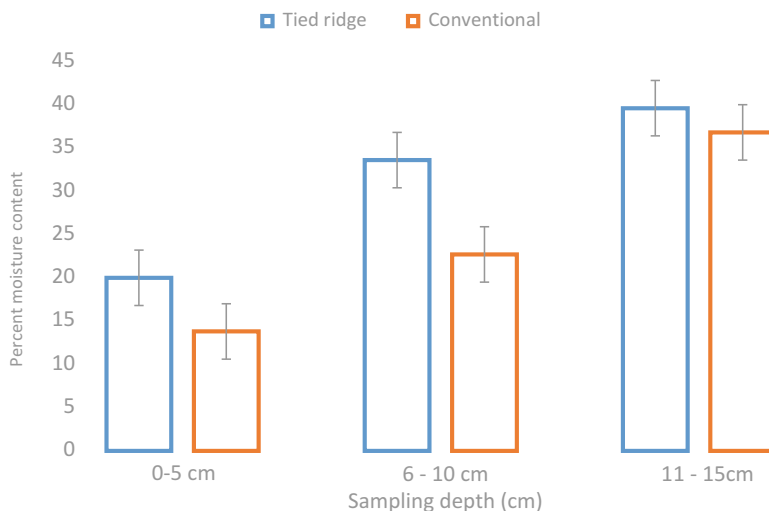
Recently, the cotton companies have promoted subsoiling and tied contours as in-field water harvesting techniques to cushion farmers against the adverse effects of climate change (Chaniwa et al. 2020). In situ water harvesting involves small movements of rainwater as surface runoff, in order to concentrate water where it is wanted most (Ibraimo and Munguambe 2007). Therefore the objectives of this study are to determine the effects of two tillage systems (conventional and tied ridges) on the performance of six cotton genotypes in semiarid northern Zimbabwe.

---

## Effects of Water Harvesting on Soil Moisture Content

The results showed that tied rides had a significantly higher ( $P < 0.05$ ) moisture content in the 0–5 and 6–10 cm depth compared to conventional system, while there were no significant differences between the two tillage systems at 11–15 cm (Fig. 4).

The results indicated that tied ridges had significantly higher percentage of moisture content at 0–5 and 6–10 but not at 11–15 cm. Higher moisture content at 0–5 cm illustrates the effectiveness of tied contours in moisture conservation on top soil horizons. The 2018–2019 season was a drought year in Zimbabwe, so the effects of the tillage method on moisture was apparent. These results are in tandem with Mupangwa et al. (2006) and Nyamadzawo et al. (2013) who reported the efficiency of tied ridges in capturing moisture and concentrating it on the root zone. Usually shallower depths are first ones to dry, hence the ability of the tied ridges to retain moisture makes the crop grow better compared to those in conventional plots; as the season was characterized by short duration, high-intensity rainfall, this might have



**Fig. 4** Effects of tillage system on percentage moisture content at three sampling depths

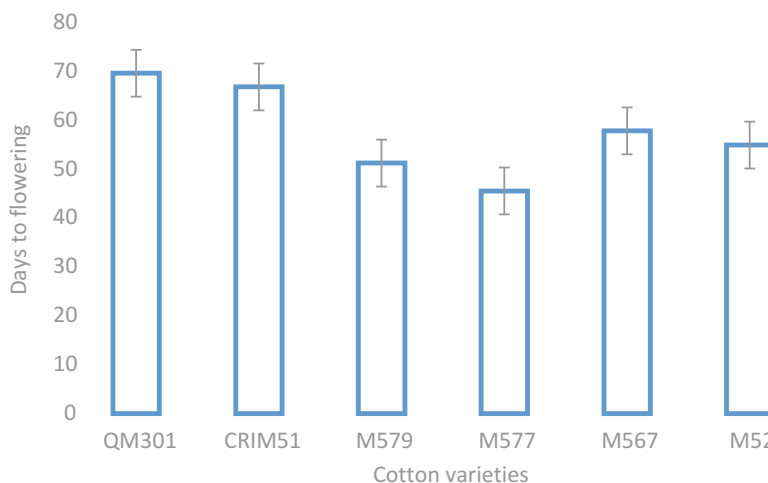
resulted in moisture loss through runoff as rainfall intensity exceeded the infiltration capacity of the soil.

This means that the use of tied ridges as moisture conservation techniques was advantageous in the cotton as plants grown in tied ridges could still absorb moisture from the top horizons while those in conventional tillage could not. Higher moisture content will be followed by higher water use efficiency and subsequently higher yields. Promoting such a technology in the communities located in marginally drier areas would increase productivity of the cotton plants and help farmers cope with dryness caused by climate change.

Tied ridges increase the amount of water in the soil profile by trapping or holding the rainfall. These structures reduce runoff from the fields and enhance infiltration. This leads to higher amounts of stored moisture. Water harvesting is currently being rejuvenated in the marginal areas as an adaptive mechanism to climate change. High-intensity rainfall causes moisture to be lost through runoff. Research done by Nyamadzawo et al. (2012) found moisture losses as much as 50% being lost to runoff from cultivated fields. Due to the erratic nature of the rainfall such losses may never be recovered.

Soil water content near field capacity allows for best combinations of sufficient air space for oxygen diffusion, greatest amounts of nutrients in soluble forms, greatest cross-sectional areas for diffusion of ions and mass flow of water, and most favorable conditions for root extension.

The days to flowering varied significantly due to the effects of cotton genotypes. The results indicated that the genotypes M579 and M 577 had significantly fewer days to flowering compared to QM301 and CRIM 51 which are the Zimbabwe varieties (Fig. 5).



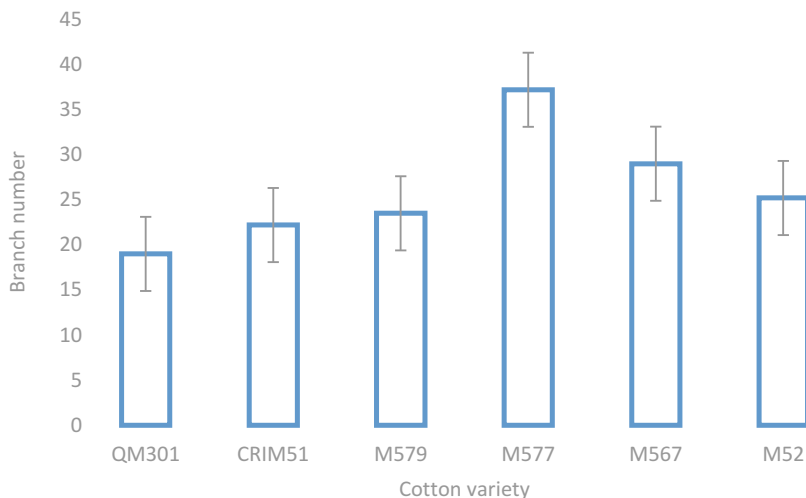
**Fig. 5** The effect of cotton varieties on days to flowering

It was observed that M579 and M577 flowered the earliest compared to the rest of the varieties (Fig. 2). The variety M577 had the highest number of productive branches (Fig. 2). This according to Kooyers (2015) illustrates drought escape. Drought escape occurs when plants develop rapidly and reproduce when the environment becomes severe. Usually a variety that develops early escapes drought due to the shortened life cycle. The early flowering varieties represent a response when the plant's genetic resources are sourced to assist farmers to adapt to the changed climate. FAO (2015) reported that the biggest challenge for future food or commerce is to find a good match between the crops and the production environment as the effects of climate change increase. The two varieties are therefore suited to the changed conditions of semiarid Zimbabwe. These genotypes were obtained from India. Singh (2017) reported that one of the breeding strategies to mitigate the effect of climate change is to improve adaptation through increased access to a number of varieties at the local level with different growth durations to escape or to avoid predictable occurrences of stress at critical periods. This reduces the vulnerability of local farmers to the effects of climate change extremes.

The cotton variety M577 had the biggest cotton branch number compared to the rest of the varieties. The locally bred varieties showed lower branch numbers compared to the imported one (Fig. 6).

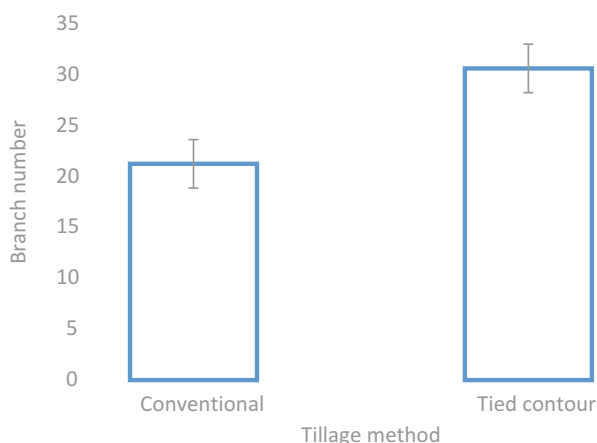
Branch number was also significantly ( $P < 0.05$ ) affected by moisture conservation method. Tied ridges had significantly higher branch number compared to conventional tillage (Fig. 6).

The hybrids showed potential for use in environments with low water availability. Obtaining hybrids with good grain yield in environments with water restriction and a significant increase in water-limited environments has been an aim of many breeding



**Fig. 6** The effect of cotton varieties on branch number

**Fig. 7** Effect of tillage method on cotton branch number



programs. Varieties with lower yield reduction in stressful environment mean stability of production which is desirable.

A combination of high bearing branch number and few days to flowering is key in selecting crop varieties suited to climate change. One major characteristic of the seasons is erratic rainfall which begins early and terminates prematurely. Other seasons have delayed start and end prematurely. Generally, most seasons are not long enough to allow most varieties from germination until it reaches maturity. The varieties M577 and M567 suit such an environment as it can escape droughts through early phenological development. Quicker production of flowering branches also indicates tolerance to drought. Therefore, introduction of varieties to small-scale farmers in Zimbabwe is for farmers’ adaptation to climate change.



For flower number the M577, M579, and M567 had the highest number of flowers. Flower number represents reproductive capacity. The same trend was observed on boll number. Higher flower numbers were observed on tied ridges compared to conventional system (Fig. 7). This showed that the varieties respond to tied ridges compared to conventional. As cotton is grown by small-scale farmers in high-risk environments, the results illustrate the suitability of these three varieties to the northern Zimbabwe environment. Adopting the three varieties to the Zimbabwean conditions illustrate Nhemachena et al. (2016)'s assertion that new crop varieties will be needed to cope with climate change. Areas with shortened seasons result in low yield potential, affecting agricultural productivity. Local breeding efforts may be slow to match the changing environments, hence the importation of genotypes that suit the environment. The new environment is forcing farmers to abandon some varieties or even abandon the crop especially if the varieties cannot withstand the new conditions.

The tied ridges gave a significantly higher branch number compared to conventional system (Fig. 5). This illustrates the suitability of the moisture conservation to maintain cotton production in arid areas which are vulnerable to climate change. Tied ridges tended to concentrate moisture on the few areas and that makes more moisture available for the crop.

The varieties M579 and M577 were the most suited to the climate of northern Zimbabwe as they performed much better than the traditional varieties which farmers have been using. Also making tied ridges improve water retention properties of the soil and leads to greater water use efficiency. Therefore adoption of tied ridges and the two varieties has potential to be an adaptive strategy that has potential to resuscitate an industry that was facing extinction due to climate change. Bringing new varieties and introducing water harvesting has been key in alleviating the effects of climate change on cotton production. The current conventional cotton varieties had failed to cope with climate change effects of reduced moisture availability. Other characteristics noted on the new varieties were very early development and increased branch number. These new varieties are better able to withstand the current adversities and keep marginalized farmers in production. The number of bolls noted per branch and on branches is all yield parameters which are critical for cotton productivity.

The cotton parameters noted above contribute to phenotypic plasticity which is the ability to cope with a wide range of environmental conditions. According to Kooyers (2015), drought escape may be optimal for annual plants in environments with shorter growing periods that are ended by severe terminal drought while drought avoidance may be optimal where if the growing season is punctuated by transient droughts.

---

## References

- Belay A, Gebrekidan H, Ulro Y (1998) Effect of tied ridges on grain yield response of Maize (*Zeamays L.*) to application of crop residue and residual N and P on two soil types at Alemaya, Ethiopia. *S Afr J Plant Soil* 15(4):123–129. <https://doi.org/10.1080/02571862.1998.10635130>
- Brazier A (2015) Climate change in Zimbabwe: facts for planners and decision makers. Konrad-Adenauer-Stiftung, Harare
- Buka G (2017) Cotton and its by-products sector in Zimbabwe. UNCTAD, Geneva

- Chaniwa M, Nyawenze C, Mandumbu R, Mutsiveri G, Gadzirayi CT, Munyati VT, Rugare JT (2020). Ending poverty through affordable credit to small scale farmers: the case of Cotton Company of Zimbabwe. In: Nhamo et al. (eds) Scaling up SDGs implementation. Sustainable development goals series. [https://doi.org/10.1007/978-3-33216-7\\_8](https://doi.org/10.1007/978-3-33216-7_8)
- Christensen JH, Hewitson B, Busuioac A, Chen A, Gao X, Held I, Jones R, Kolli RK, Kwon W-T, Laprise R, Magaña Rueda V, Mearns L, Menéndez CG, Räisänen J, Rinke A, Sarr A, Whetton P (2007) Regional climate projections. In: Solomon S, Qin D, Manning M, Chen Z, Marquis M, Averyt KB, Tignor M, Miller HL (eds) *Climate change 2007: the physical science basis. Contribution of working group I to the fourth assessment report of the intergovernmental panel on climate change*. Cambridge University Press, Cambridge, UK/New York
- FAO (2012) *Climate change adaptation and mitigation*. FAO, Rome
- FAO (2015) *Coping with climate change-the role of genetic resources for food and agriculture*. FAO, Rome
- FEWSNET (2019) Late and below normal rains and economic hardships expected to impact poor households food access. USAID
- Fischer G, Shah M, van Velthuisen H (2002) *Climate change and agricultural variability, a special report, on Climate change and agricultural vulnerability, contribution to the world summit on sustainable development. Johannesburg 2002 (Global, agriculture)*
- Global Agricultural Information Network (2017) *Cotton production and consumption in Zimbabwe*. USDA Foreign Agric Service
- Ibraimo N and Munguambe P (2007) *rainwater harvesting technologies for small scale rainfed agriculture in arid and semi-arid areas*. Paper presented at the Integrated water resource management for improved livelihoods. CGIAR challenge program on water and food. South Africa
- Katengeza SP, Holden ST, Lunduka RW (2019) Adoption of drought tolerant maize varieties under rainfall stress in Malawi. *J Agric Econ* 70:198–214
- Kooyers NJ (2015) The evolution of drought escape and avoidance in natural herbaceous populations. *Plant Sci* 234:155–162
- Mandumbu R (2011) *Seedbank dynamics in conservation agriculture in south western Zimbabwe*. Lambert Academic Publishers, Germany
- Mapfumo P, Chuma E, Nyagumbo I, Mutambanengwe F (2002) *Farmer field schools: facilitator manual; integrated soil water and nutrient management in semi-arid Zimbabwe*. FAO of UN, Zimbabwe
- Mazvimavi K, Twomlow SJ (2007) *Conservation farming for agricultural relief and development in Zimbabwe*. ICRISAT, Matopos Research Station, Bulawayo
- McHugh OV, Steenhuis TS, Abebe B, Fernandes ECM (2007) Performance of in situ rainwater conservation tillage techniques on dry spell mitigation and erosion control in the drought-prone North Wello zone of the Ethiopian highlands. *Soil Tillage Res* 97:19–36
- Meldrum G, Mijatovic D, Rojas W, Flores J, Pinto M, Mamani G, Condori E, Hilaquith D, Grumberg H, Pdulosi S (2017) Climate change and crop diversity: farmers' perception and adaptation on the Bolivian Altipano. *Environ Dev Sustain*. <https://doi.org/10.1007/s10668-016-9906-4>
- Mujeyi K (2013) Viability analysis of smallholder cotton production under contract farming in Zimbabwe. Invited paper presented at the 4th international conference of the African association of agricultural economists, September 22–25, 2013, Hammamet
- Mupangwa W, Love D, Twomlow SJ (2006) Soil water conservation and rainwater harvesting strategies in semi-arid Mzingwane catchment Limpopo Basin, Zimbabwe. *Phys Chem Chem*. <https://doi.org/10.1016/j.jpce.2006.08.042>
- Nhemachena C, Matchaya G, Nhlengetwa S, Nhemachena CR (2016) Economic aspects of genetic resources in addressing agricultural productivity in the context of climate change. In: Lal R et al (eds) *Climate change and multidimensional sustainability in African agriculture*. [https://doi.org/10.1007/978-3-319-41238-2\\_9](https://doi.org/10.1007/978-3-319-41238-2_9)
- Nyamadzawo G, Nyamugafata P, Wuta M, Nyamangara J, Chikowo R (2012) Infiltration and runoff losses under fallowing and conservation agriculture practices on contrasting soils, Zimbabwe. *Water SA* 38(2):233–240

- Nyamadzawo G, Wuta M, Nyamangara J, Gumbo D (2013). Opportunities for optimisation of infield water harvesting to cope with changing climate in semi-arid smallholder farming areas of Zimbabwe. *Springer Plus* 2:100
- Rockström J, Falkenmark M (2000) Semiarid crop production from a hydrological perspective: gap between potential and actual yields. *Crit Rev Plant Sci* 19:319–346
- Singh RP (2017) Improving seed systems resiliency and local level through participatory approaches to adaptation to climate change. *Adv Plants Agric Res* 6:15–16
- Thomas M, Thepot S, Galic N, Jovanne-Pin S, Remone C, Goldringer I (2015) Diversifying mechanisms in the on-farm evolution of crop mixtures. *Mol Ecol* 24:2937–2954
- Twomlow SJ, Hove L (2007) Is conservation agriculture an option for vulnerable households in southern Africa. Paper presented at the conservation agriculture for sustainable land management to improve livelihoods for people in dry areas workshop, 7–9 May 2007, Damascus
- UNEP (1997) Source book of alternative technologies for fresh water augmentation in Latin America and the Caribbean. International Environmental Technology Center, United Nations Environment Programme, Washington, DC
- UNFCCC (2007) Climate change impacts, vulnerabilities and adaptation in developing countries. UNFCCC, Bonn

**Open Access** This chapter is licensed under the terms of the Creative Commons Attribution 4.0 International License (<http://creativecommons.org/licenses/by/4.0/>), which permits use, sharing, adaptation, distribution and reproduction in any medium or format, as long as you give appropriate credit to the original author(s) and the source, provide a link to the Creative Commons license and indicate if changes were made.

The images or other third party material in this chapter are included in the chapter's Creative Commons license, unless indicated otherwise in a credit line to the material. If material is not included in the chapter's Creative Commons license and your intended use is not permitted by statutory regulation or exceeds the permitted use, you will need to obtain permission directly from the copyright holder.





# Determinants of Cattle Farmers' Perception of Climate Change in the Dry and Subhumid Tropical Zones of Benin (West Africa) 11

Yaya Idrissou, Alassan Seidou Assani, Mohamed Nasser Baco, and Ibrahim Alkoiret Traoré

## Contents

Introduction .....	198
Material and Methods .....	199
Study Areas .....	199
Data Collection .....	201
Statistical Analysis .....	202
Results and Discussion .....	203
Sociodemographic Characteristics of the Cattle Farmers Surveyed .....	203
Cattle Farmers' Perception of Climate Change Indicators .....	204
Determinants of Cattle Farmers' Perception of Climate Change .....	205
Cattle Farmers' Adaptation Strategies to Climate Change .....	207
Conclusion .....	209
References .....	209

## Abstract

Understanding the factors influencing the perception of climate change can help improve policies for strengthening the adaptive capacity of pastoralists with regard to climate change. Despite this importance, few studies have focused on this issue,

This chapter was previously published non-open access with exclusive rights reserved by the Publisher. It has been changed retrospectively to open access under a CC BY 4.0 license and the copyright holder is "The Author(s)". For further details, please see the license information at the end of the chapter.

Y. Idrissou (✉) · A. S. Assani · I. Alkoiret Traoré  
Laboratoire d'Ecologie, Santé et Production Animales (LESPA), Faculté d'Agronomie, Université de Parakou, Parakou, République du Bénin  
e-mail: [yayaidriss2617@gmail.com](mailto:yayaidriss2617@gmail.com); [alassanassani@gmail.com](mailto:alassanassani@gmail.com); [alkouarit@gmail.com](mailto:alkouarit@gmail.com)

M. N. Baco  
Laboratoire Société-Environnement (LaSEn), Faculté d'Agronomie, Université de Parakou, Parakou, République du Bénin  
e-mail: [nasserbaco@yahoo.fr](mailto:nasserbaco@yahoo.fr)

especially among cattle farmers. In order to attempt filling this gap, this study analyzed the determinants of the perception of climate change by cattle farmers distributed in the dry and sub-humid tropical zones of Benin as well as the current adaptation strategies developed by these farmers. For this purpose, surveys were carried out through group discussions and an individual questionnaire administered to 360 cattle farmers in the two climatic zones. The data collected related to the sociodemographic characteristics of cattle farmers and their perception of climate change and adaptation strategies. A binary logit model has identified the factors that influence cattle farmers' perceptions of climate change. The results of the study showed that cattle farmers perceive a drop in rain (at least 77%), an increase in temperature (at least 80%), and violent winds (at least 60%). Breeding experience, level of education of the farmer, household size, membership of a breeders' organization, and cattle herd size determine these perceptions. Four major groups of adaptation strategies have been developed by farmers to cope with climate change. These are production adjustment strategies, activity diversification strategies, livestock management strategies, and selection strategies. The political implication of this study is that government and development partners should integrate these factors into projects and programs related to climate change.

---

**Keywords**

Animal · Climatic zone · Climate change · Adaptation strategies · West Africa

---

**Introduction**

Climate change is currently an increasingly visible threat to the viability of the rural population of sub-Saharan Africa, where communities depend mainly on the exploitation of natural resources (Kaboré et al. 2019; Adimassu and Kessler 2016). Livestock rearing is one of the main economic activities on which the poorest people in sub-Saharan Africa depend as a source of food and income. Despite its importance, livestock is currently threatened by climate change (Apata et al. 2009; Deressa et al. 2009) because of its high dependence on natural resources specifically fodder and water (Idrissou et al. 2019; IUCN 2010). The impacts of climate change in the livestock sector are felt in the production and quality of forage crops (Polley et al. 2013; Chapman et al. 2012), water availability, animal growth, milk production, reproduction, and disease (Henry et al. 2012). Faced with this situation, the challenge for the scientific community is to produce knowledge enabling farmers to anticipate the effects of climate change on their system and to develop methods and tools to adapt to it (Sautier 2013). To achieve this, it is necessary to understand how pastoralists perceive climate change (Deressa et al. 2011), as this influences the way they manage climate-related risks and opportunities, as well as the strategies put in place to adapt (Mamba 2016). In developing countries, numerous studies have dealt with the perception and adaptation strategies of pastoralists in the face of climate change (Idrissou et al. 2020; Sanou et al. 2018; Ayanlade et al. 2017). In Benin, for

example, several studies show that pastoralists perceive climate change through the drop in rain, irregular rainfall, and late start and early end of the rainy season (Idrissou et al. 2020; Dossa et al. 2017; Zakari et al. 2015). Pastoralists in Burkina Faso have unanimously discerned some changes in precipitation and temperature (Sanfo et al. 2015). They saw a decrease in annual precipitation, an increase in the intensity of precipitation, and the frequency of flooding. In Kenya, pastoralists have reported changes in the amount and distribution of precipitation, fog, temperature, and wind over the past 20 to 30 years (Cuni-Sanchez et al. 2019). To cope with the harmful effects of climate change, pastoralists in developing countries have developed several strategies such as herd mobility, storage of crop residues, and integration of livestock rearing with crop farming, among others (Idrissou et al. 2019).

These studies, although they allow apprehending the perceptions and adaptation strategies of cattle farmers, are still insufficient. Indeed, information on the factors that determine the perceptions of pastoralists has not often been analyzed. Knowledge of this aspect is important for science and will allow better targeting of policies to support the adaptation of pastoralists to climate change in developing countries.

Benin, a small country in West Africa, has three climatic zones, the most vulnerable to climate change being the dry and sub-humid tropical zones (Gnanglè et al. 2011; MEHU 2011). It is in these most vulnerable areas that more than 85% of the country's cattle farms are concentrated (Alkoiret et al. 2011). These cattle farms will be severely affected by the effects of climate change, resulting in reduced productivity (Nardone et al. 2010). Pastoralists in these zones are thus exposed to risks of food insecurity and increasing poverty. A study analyzing the perception and adaptation strategies of pastoralists in these areas in the face of climate change is timely as it can help improve policies aimed at supporting these pastoralists to adapt sustainably to climate change (Folefack and Tenikue 2015; Mabe et al. 2014). The aims of this study are therefore to (i) analyze the determinants of the perception of climate change by cattle farmers in the dry and sub-humid tropical zones of Benin and (ii) identify the current adaptation strategies developed by these farmers.

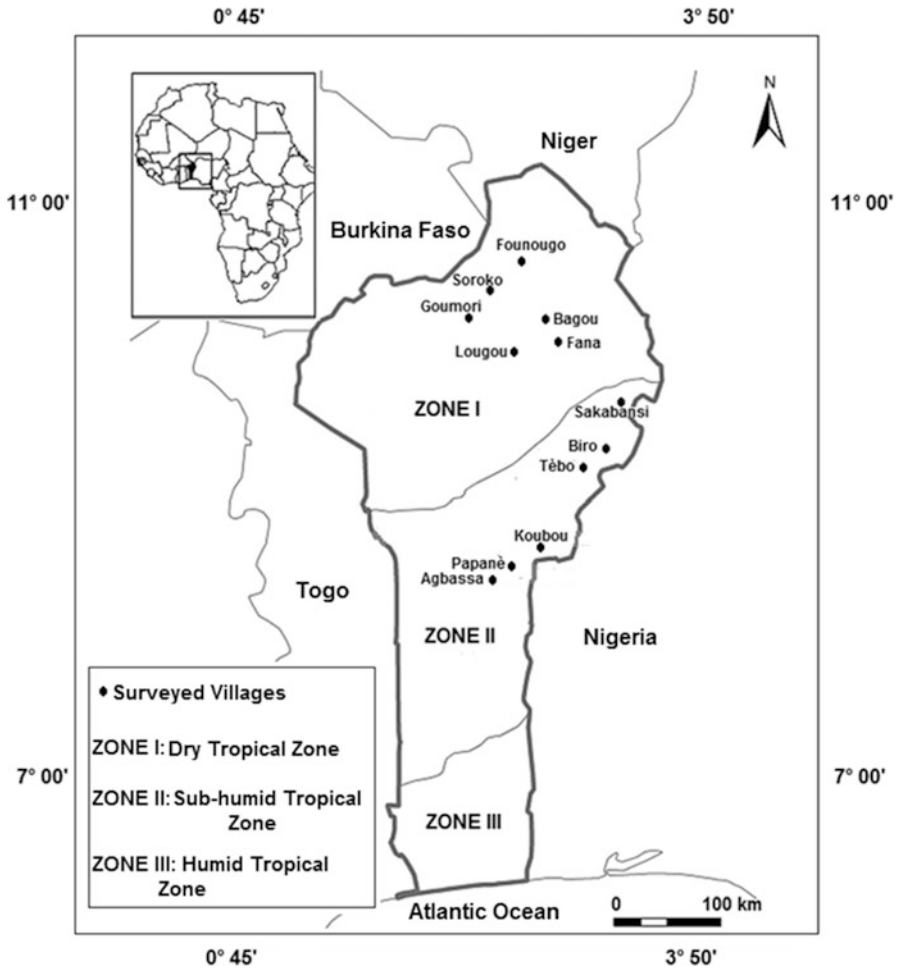
---

## Material and Methods

### Study Areas

This study was carried out in two of the three climatic zones of Benin (located 6° and 12° 50' N and 1° and 3° 40' E). These are the dry tropical zone between 9° 45' and 12° 25' N and the sub-humid tropical zone located between 7° 30' and 9° 45' N (Fig. 1). The choice of these zones is based on the fact that climate forecasts indicate that they are the most vulnerable to rainfall deficit and high sunshine (Gnanglè et al. 2011; MEHU 2011), yet more than 85% of the Beninese cattle herd is concentrated in these zones (Alkoiret et al. 2011).

In each zone, two (2) municipalities were chosen based on the large number of cattle farmers and preliminary interviews with technicians from the "Agences Territoriales pour le Développement Agricole" (ATDA). Thus, the municipalities



**Fig. 1** Location of the villages surveyed in Benin

of Tchaourou and Nikki were selected in the sub-humid tropical zone and those of Gogounou and Banikoara in the dry tropical zone. Within each municipality, three villages have been selected (Fig. 1). In the dry tropical zone, which includes the municipalities of Gogounou and Banikoara, the mean annual rainfall is often less than 1000 mm, and the relative humidity varies from 18 to 99% (highest in August). The temperature varies from 24 °C to 31 °C. The soils in this zone are hydromorphic, well-drained soils, and lithosols. The vegetation of this zone is mainly composed of savannas with trees of smaller size. The sub-humid tropical zone, made up of the municipalities of Tchaourou and Nikki, is characterized by unimodal precipitation, from May to October, and lasts about 113 days with an annual mean rainfall varying between 900 and 1110 mm. The annual temperature ranges from 25 °C to 29 °C and

the relative humidity from 31% to 98%. Soils in this zone are ferruginous with variable fertility. The vegetation of the sub-humid tropical zone is characterized by a mosaic of woodland, dry dense forests, tree and shrub savannas, and gallery forests.

## Data Collection

Data collection was carried out from November 2018 to April 2019 in two stages that include the exploratory study and in-depth interviews.

### Exploratory Study

During this phase, interviews were carried out with technicians from the ATDA in order to identify the villages and cattle farmers to be surveyed. On the basis of the defined criteria, with the local technicians, the villages of Koubou, Papanè, and Agbassa were identified in the municipality of Tchaourou; the villages Tèbo, Biro, and Sakabansi in the municipality of Nikki; the villages of Bagou, Fana, and Lougou in the municipality of Gogounou; and finally those of Founougo, Goumori, and Soroko in the municipality of Banikoara (Fig. 1).

After identifying the villages, focus groups of staff varying from 6 to 15 people were carried out (one focus group per village). During the focus groups, the questions were open and made it possible to record the maximum of responses on the perceptions and adaptation strategies of cattle farmers. At the end of these focus groups, a list of climatic parameters cited by cattle farmers was drawn up. These climatic parameters have been broken down into different indicators of their manifestations as cited by farmers. A global synthesis was made to constitute the content of the questionnaire for in-depth interviews.

The interviews carried out during the exploratory study made it possible to randomly select 30 cattle farmers per village to whom questions were addressed individually for the continuation of the study. Thus, a total of 360 cattle farmers were surveyed during this study. The criteria for choosing cattle farmers were having cattle breeding as their main activity and being at least 50 years old. The choice of breeding as the main activity to discriminate the respondents is justified by the fact that several studies focus on agro-pastoralists and generalize the results obtained both to agro-pastoralists and to pastoralists. However, these socio-professional categories face different socioeconomic problems (Zampaligré et al. 2014). The age barrier (50 years) is explained by the fact that climate change is very slow and elderly people are needed to have reliable historical information (Kaboré et al. 2019; Bambara et al. 2016).

### In-Depth Interviews

The in-depth interview consisted of collecting data through semi-structured interviews with the 360 cattle farmers identified during the exploratory study. For data collection, local investigators were recruited and trained. The training of local investigators was undertaken for a week and piloted before the start of interviews with cattle farmers. The aim of the training was to minimize bias and errors in data



collection. The interviewers used to conduct the interviews with the cattle farmers were selected from each study village and understood the local language of the village. The data were collected using a questionnaire. A first series of questions related to the sociodemographic characteristics of the cattle farmers (sex, age, breeding experience, ethnic group, household size, number of agricultural assets, level of education, contact with agricultural extension services, membership of a breeders' organization, etc.) and a second series of questions concerned the perception of climate change indicators as well as the adaptation strategies developed. The questions posed to farmers on their perception of climate change are consistent with the indices of the Expert Team on Climate Change Detection Monitoring and Indices (ETCCDMI) (Zhang and Yang 2004). Climate change indicators are meteorological parameters whose evolution over time reflects climate change. These indicators are total annual precipitation, rainfall intensity, daily maximum, and minimum temperatures. Other parameters were also taken into account including "rainless days" or pockets of drought, vortex, and strong winds (Bambara et al. 2016; Salack et al. 2012).

## Statistical Analysis

The data from the surveys were processed using the Statistical Package for Social Sciences (SPSS) version 17. Frequencies of responses were reported and compared with chi-square ( $\chi^2$ ) test. The quantitative variables describing the cattle farmers surveyed were presented as means  $\pm$  standard deviations and compared between climatic zones using the Mann-Whitney U nonparametric test (McDonald 2009).

The determinants that influence cattle farmers' perception of climate change have been analyzed by binary logistic regression (Kaboré et al. 2019; Uddin et al. 2017). The equation of the binary model is as follows:

$$Y_i = X_i \beta + \epsilon_i \quad (1)$$

where  $Y_i$  is the variable which takes the value 1 if the farmer perceives a climate change indicator and 0 if he does not perceive it;  $X_i$  is the set of explanatory variables indicating the factors that influence the cattle farmers' perception of climate change; and  $\epsilon_i$  is the standard error.

Before estimating the logistic regression model, the explanatory variables were checked to determine the existence of multi-collinearity, using the contingency coefficient test (Uddin et al. 2017). A collinearity was observed between the breeding experience and age; between the number of agricultural assets and household size; and between membership of a breeders' organization and contact with extension services. Consequently, age, number of agricultural assets, and contact with extension services were omitted from the logistic regression model after the multi-collinearity test. The explanatory variables used for the regressions are sex, breeding experience, ethnic group, level of education, location (climatic zone), membership to a breeders' organization, household size, and herd size.

## Results and Discussion

### Sociodemographic Characteristics of the Cattle Farmers Surveyed

The sociodemographic characteristics of the cattle farmers surveyed are summarized in Table 1. The majority of the cattle farmers surveyed are of the Fulani sociocultural group (80.83%) and of the male sex (92.5%). They are relatively old ( $56.43 \pm 5.88$  years) and have an average experience of 30 years in cattle breeding. Cattle farmers in the sub-humid tropical zone were older and more experienced ( $p < 0.05$ ) than those in the dry tropical zone. Very few cattle farmers have been educated (5%). The household size of the cattle farmers surveyed was on average 11 people, and the cattle herd size was on average 64 heads. A large number of cattle farmers are members of an organization (90.92%) and are also in contact with agricultural extension services (66.21%). It is specified that the number of cattle farmers in contact with agricultural extension services in the dry tropical zone is significantly high ( $p < 0.05$ ) compared to that of the sub-humid tropical zone. This could be explained by the fact that historically the dry zone is an area purely dedicated to animal husbandry, which leads technicians leaving agricultural college and university to settle more in this zone. Additionally, the first livestock extension structures were created in the dry zone.

**Table 1** Sociodemographic characteristics of cattle farmers

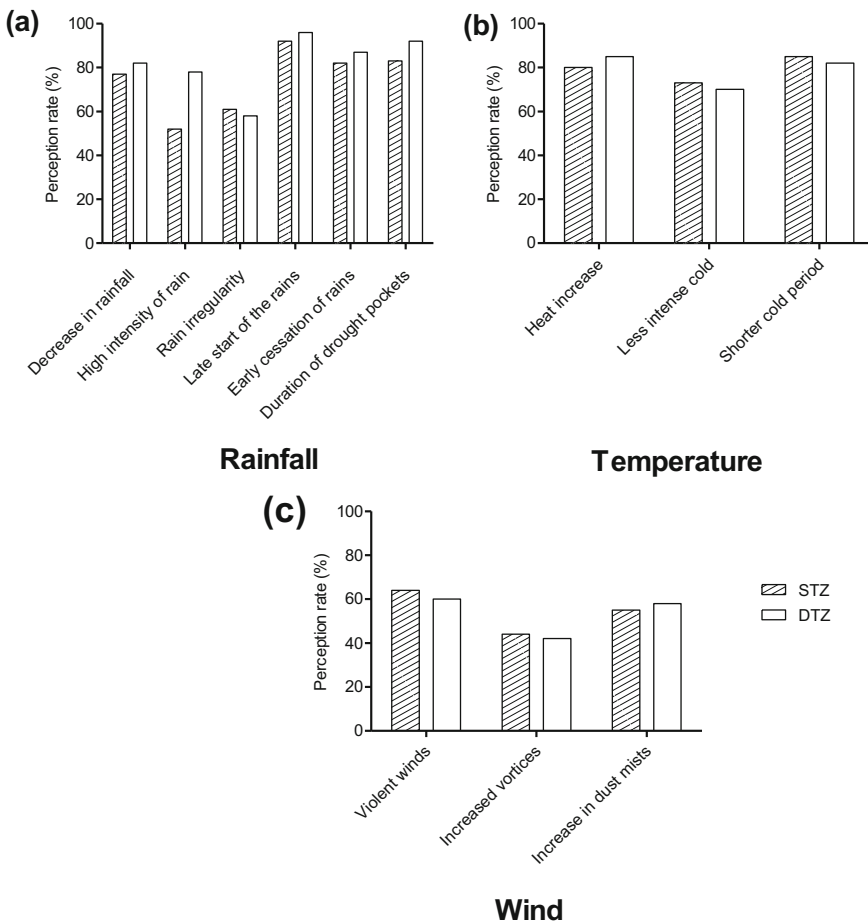
Variables	Climatic zones		Total
	STZ	DTZ	
<i>Percentage (%)</i>			
<i>Sex</i>			
Male	95.00 <sup>a</sup>	90.00 <sup>a</sup>	92.50
Female	5.00 <sup>a</sup>	10.00 <sup>a</sup>	7.50
<i>Ethnic group</i>			
Fulani	80.00 <sup>a</sup>	81.67 <sup>a</sup>	80.83
Bariba	20.00 <sup>a</sup>	18.33 <sup>a</sup>	19.17
<i>Level of education</i>			
Educated	6.67 <sup>a</sup>	3.33 <sup>a</sup>	5.00
Non-educated	93.33 <sup>a</sup>	96.67 <sup>a</sup>	95.00
Membership in an organization	88.33 <sup>a</sup>	93.50 <sup>a</sup>	90.92
Contact with the extension	60.67 <sup>a</sup>	71.75 <sup>b</sup>	66.21
<i>Mean <math>\pm</math> standard deviation</i>			
Age	57.95 $\pm$ 6.52 <sup>a</sup>	54.91 $\pm$ 4.7 <sup>b</sup>	56.43 $\pm$ 5.88
Breeding experience	34.37 $\pm$ 10.95 <sup>a</sup>	25.75 $\pm$ 8.4 <sup>b</sup>	30.05 $\pm$ 10.63
Number of agricultural assets	8.55 $\pm$ 3.64 <sup>a</sup>	7.16 $\pm$ 3.25 <sup>a</sup>	7.85 $\pm$ 3.50
Household size	11.70 $\pm$ 4.64 <sup>a</sup>	11.71 $\pm$ 4.81 <sup>a</sup>	11.70 $\pm$ 4.71
Cattle herd size	61.28 $\pm$ 41.59 <sup>a</sup>	67.72 $\pm$ 35.46 <sup>a</sup>	64.50 $\pm$ 38.62

STZ sub-humid tropical zone, DTZ dry tropical zone

<sup>a</sup>, <sup>b</sup>The values of the same line indexed by different letters are significantly different at the 5% threshold

### Cattle Farmers' Perception of Climate Change Indicators

Seventy-seven percent (77%) of cattle farmers in the sub-humid tropical zone and 82% in the dry tropical zone perceived a decrease in rainfall (Fig. 2a). The indicator “high intensity of rainfall” was perceived by 78% of the cattle farmers of the dry tropical zone against 52% of the cattle farmers of the sub-humid tropical zone. In the both zones, indicators of change in precipitation such as the duration of the drought pocket, the late onset, and the early cessation of the rains were perceived by more than 80% of the farmers interviewed. At least 50% of the farmers in both zones perceived an irregularity in the rains. These indicators of change in precipitation perceived by pastoralists could be explained by the fact that these indicators remain the most visible in the observation of rainfall jeoporation in Africa (Bambara et al.



**Fig. 2** Perception of indicators of changes in rainfall (a) in temperature (b) and wind (c) by cattle farmers in the dry (white) and sub-humid (black) tropical zones of Benin

2013). These results therefore confirm the work of several authors in Africa (Cuni-Sanchez et al. 2019; Opiyo et al. 2016).

The majority (at least 80%) of cattle farmers in the both zones recognize that the heat is getting stronger (Fig. 2b). These results reflect an increase in maximum and minimum daily temperatures observed throughout the year. Farmers also indicated that the cold season is warming up (70% and 73% of the cattle farmers in the dry and sub-humid tropical zones respectively) and tends to become shorter (82% in the dry zone and 85% in the sub-humid zone). As the temperature is a direct feeling, the farmers can easily see its increase through warmer days and nights. In addition, high temperatures cause animals to seek more shade and water (Idrissou et al. 2020). This behavior of animals observed by farmers could also explain their perception of the increase in temperature.

According to 60% of cattle farmers in the dry tropical zone and 64% of the farmers in the sub-humid tropical zone, the winds have become more and more violent (Fig. 2c). The increase in vortices was reported by at least 40% of cattle farmers in the both zones. In addition, more than 50% of the cattle farmers in the two zones perceived an increase in dust mists. Strong winds cause material damage such as destruction of roofs, erosion of cultivable land, uprooting of trees, etc. This damage noted by farmers could explain their perception. Similar perceptions have been reported by several authors in other parts of Africa (Limantol et al. 2016; Opiyo et al. 2016).

## Determinants of Cattle Farmers' Perception of Climate Change

The analysis of binary logistic regression performed to determine the factors that influence the farmers' perception of the change in precipitation and temperature is summarized in Table 2. The variable "Breeding Experience" positively affects perceptions of reduced rainfall and late onset and early cessation of rains. This result indicates that farmers with longer years of cattle breeding experience were more likely to perceive climate change. In addition, experienced farmers observe changes over time and compare them to current climatic conditions, allowing them to quickly perceive climate change. This result is similar to those obtained by several authors (Sanogo et al. 2017; Uddin et al. 2017).

The level of education of the cattle farmers positively influences the perception of the late onset of the rains at the threshold of 10% (Table 2). The most educated farmers are more interested in calendar dates or the start of school holidays, which generally coincide with the start of winter (Kaboré et al. 2019). The less educated do not really make the difference between an early or late season.

Membership of a breeders' organization influences cattle farmers' perception of reduced rains and late onset and early cessation of rains. Breeders' organizations benefit from training from development partners through non-governmental organizations (NGOs), agricultural development projects, and programs. Through these different structures, cattle farmers are made aware of climate change as well as the present and future consequences on their livelihood. In addition to these sources of

**Table 2** Determinants of cattle farmers' perception of change in precipitation and temperature

Variables	Decrease in rainfall			Late start of the rains			Early cessation of rains			Heat increase		
	$\beta$	SE $\beta$	p	$\beta$	SE $\beta$	p	$\beta$	SE $\beta$	p	$\beta$	SE $\beta$	p
Constant	0.224*	2.458	0.0927	7.020***	2.528	0.005	3.887*	2.329	0.095	4.956	3.346	0.139
Climatic zone	0.652	0.522	0.212	0.202	0.459	0.659	0.277	0.459	0.546	1.051	0.608	0.840
Breeding experience	0.077*	0.043	0.074	0.093**	0.039	0.018	0.077**	0.037	0.041	0.017	0.056	0.763
Sex	2.210	0.992	0.26	1.223	0.800	0.126	0.021	0.735	0.977	1.543	1.204	0.20
Ethnic group	0.020	0.543	0.97	0.782	0.502	0.12	-0.524	0.504	0.298	0.291	0.636	0.647
Education level	1.536	1.224	0.209	0.363*	0.930	0.0696	0.925	0.954	0.332	0.893	1.187	0.452
Household size	0.029	0.046	0.521	0.018	0.043	0.673	0.023	0.042	0.579	0.117**	0.056	0.039
Membership in an organization	0.351*	0.614	0.0568	-0.246*	0.571	0.0666	-0.426**	0.561	0.0447	0.091	0.751	0.903
Cattle herd size	0.004**	0.005	0.0382	0.061**	0.050	0.042	0.008*	0.005	0.0706	0.011*	0.006	0.087
Number of observations	360			360			360			360		
-2log likelihood	14.33			153.56			154.94			102.56		
Prob > Chi	0.009			0.019			0.025			0.000		

\*significant value at 10% (0.05 < p ≤ 0.10); \*\*significant value at 5% (0.01 < p ≤ 0.05); \*\*\*significant value at 1% (p < 0.01)

learning are the relationships that cattle farmers have with each other which serve as channels for sharing experiences.

Household size positively influenced the cattle farmers' perception of the increased heat. This finding indicates that with increasing household size, the likelihood that cattle farmers perceive climate change increases. Milk represents an essential constituent of the food ration of Fulani cattle farmers and also generates income for their households (Alkoiret et al. 2010). Climate change is causing a decrease in the milk production of animals (Henry et al. 2012). Large households are therefore no longer able to meet the milk demand of their large families. This is why cattle farmers can more easily detect climate change (Kosmowski et al. 2016).

Cattle herd size has also influenced cattle farmers' perception of the increase in heat, the decrease in rainfall, and the late onset and the early cessation of rains. This means that farmers with large numbers of cattle perceive climate change better than those with small numbers due to the high demand for water and forage. This result is similar to that obtained among Turkana cattle farmers in northwestern Kenya (Opiyo et al. 2016).

## Cattle Farmers' Adaptation Strategies to Climate Change

To adapt to climate change, cattle farmers in the dry and sub-humid tropical zones of Benin have developed several strategies (Table 3). These strategies can be grouped

**Table 3** Adaptation strategies of cattle farmers in the dry and sub-humid tropical zones of Benin in the face of climate change

Adaptation strategies		Total	Climatic zones		$\chi^2$	p-Value
Strategy group	Type of strategy		DTZ	STZ		
Production adjustment strategies	Forage cropping	31.1	10 <sup>a</sup>	52.2 <sup>b</sup>	72.9	<0.0001
	Storage of crop residues	76.1	82.2 <sup>a</sup>	70 <sup>b</sup>	6.7	0.009
	Making hay	18.9	19.4 <sup>a</sup>	18.3 <sup>a</sup>	0.01	0.89
	Night grazing	14.4	13.9 <sup>a</sup>	15 <sup>a</sup>	0.02	0.88
	Use concentrated feed	72.8	77.8 <sup>a</sup>	67.8 <sup>b</sup>	4.05	0.04
Activities diversification strategies	Integration livestock-crop	83.9	95 <sup>a</sup>	72.8 <sup>b</sup>	31.2	<0.0001
	Fattening	15.3	11.1 <sup>a</sup>	19.4 <sup>a</sup>	3.68	0.051
	Off-farm activities	25.6	15 <sup>a</sup>	36.1 <sup>b</sup>	19.9	<0.0001
Livestock management strategies	Herds destocking	70	77.8 <sup>a</sup>	62.2 <sup>b</sup>	9.6	0.001
	Livestock diversification	58.9	92.8 <sup>a</sup>	25 <sup>b</sup>	167.9	<0.0001
	Pastoral mobility	96.1	100 <sup>a</sup>	92.2 <sup>b</sup>	12.5	0.0003
Selection strategies	Breeding local breeds	2.3	19.4 <sup>a</sup>	21.1 <sup>a</sup>	0.06	0.79
	Cross between local breed and breed adapted to heat	25.3	31.7 <sup>a</sup>	18.9 <sup>b</sup>	7.1	0.007

DTZ dry tropical zone, STZ sub-humid tropical zone

<sup>a</sup>, <sup>b</sup>The values of the same line indexed by different letters are significantly different at the 5% threshold

into four major groups of strategies, namely, production adjustment strategies, activities diversification strategies, livestock management strategies, and selection strategies. This classification is similar to that developed by Calvosa et al. (2010).

The production adjustment strategies consist of the storage of crop residues, use of concentrated feed, forage cropping, making hay, and night grazing. The adoption rates for the storage of crop residues (82.2%) and the use of feed concentrates (72.8%) were significantly higher ( $p < 0.05$ ) in the dry tropical zone than in the sub-humid tropical zone. Conversely, forage cropping (52.2%) was more adopted ( $p < 0.0001$ ) by cattle farmers in the sub-humid tropical zone. Indeed, the rainfall and the number of rainy days recorded in the sub-humid zone being higher than that obtained in the dry zone could favor the forage cropping in this zone. Also, as the climatic conditions are not conducive to the forage cropping in the dry zone, this leads cattle farmers in this zone to resort to other strategies such as the use of feed concentrates and the storage of crop residues to feed the animals.

Integration of livestock rearing and crop cultivation, fattening, and off-farm activities are the types of strategies contained in the activities under the diversification strategies category. The practice of fattening did not vary significantly ( $p > 0.05$ ) from one climatic zone to another. On the other hand, the integration livestock and crop was more adopted ( $p < 0.0001$ ) in the dry zone than in the sub-humid zone. This result means that pastoralists have moved to agro-pastoralism. Indeed, milk was the staple food for Fulani cattle farmers (Alkoiret et al. 2010), but with the fall in milk production due to climate change, the consumption of cereals has increased. To obtain these cereals, cattle farmers exchanged milk for these products with farmers. But today, given the decrease in crop yield and the strong demand due to the demographic surge, cereals are inaccessible because their prices have increased, making the exchange of products difficult. This may be the reason why cattle farmers integrate livestock and crop because they are convinced that livestock cannot be their only source of food. This result is similar to those obtained in Burkina Faso by Sanfo et al. (2015). Off-farm activities were more practiced by cattle farmers in the sub-humid tropical zone ( $p < 0.0001$ ) than those in the dry zone. This could be explained by the fact that the sub-humid tropical zone is an area which abounds in urban centers of a commercial nature, which could facilitate trade. Thus, income from off-farm activities can be used by cattle farmers to increase the level of investment in inputs such as labor, feed concentrates, and veterinary products.

Herd destocking, livestock diversification, and pastoral mobility, all of which are livestock management strategies, were adopted more in the dry zone ( $p \leq 0.001$ ) than in the sub-humid zone. Indeed, the insufficiency of forage due to the precariousness of the rains pushes the cattle farmers having a large number of cattle to practice the transhumance to reduce the risk of mortality (Kiema et al. 2013). In addition, other cattle farmers are forced to reduce the size of their herd (Kima et al. 2015; Oyekale 2014). Livestock diversification through the introduction of small ruminants into the breeding constitutes a real advantage for the farmers because of their low food needs, their larger feeding areas, and their higher reproduction rates (IUCN 2010).

Breeding local breeds adapted to local climatic conditions, and the crossing between local breeds and heat-resistant breeds were the two selection strategies

implemented by the cattle farmers in both zones. The adoption rates for the first strategy were not significantly different ( $p < 0.05$ ) in the two study zones. On the other hand, crossbreeding between local breeds and heat-resistant breeds as an adaptation strategy was more adopted in the dry zone ( $p = 0.007$ ) than in the sub-humid zone. This could be explained by the fact that the dry zone is a pre-Saharan zone where there is a high temperature, therefore requiring the breeding of heat-resistant animals.

---

## Conclusion

The manifestations of climate change are perceived by cattle farmers in the dry and sub-humid tropical zones of Benin. The changes in rainfall are felt through signs such as reduced rainfall and late start and early end of the rainy seasons. Changes in temperature and wind were felt through increased heat and violent winds. This study showed that the sociodemographic characteristics of cattle farmers such as the level of education and membership of an organization influence local perceptions of climate change.

Adaptation strategies implemented by cattle farmers can be grouped into four main groups. These are production adjustment strategies, activities diversification strategies, livestock management strategies, and selection strategies. These current developed strategies allow farmers to take advantage of their livelihood.

Based on the results of this study, there is a need to strengthen the adaptive capacities of farmers in both zones through their access to education and training on adaptation to climate change within breeders' organizations. These help to improve their perception of this phenomenon and help them to better develop adaptation strategies. Climate information is needed to enable them to increase production to achieve food security. In addition, endogenous climate change indicators should be further promoted, as they allow farmers to predict the course of the rainy season and guide them better in implementing their adaptation strategies to climate change.

**Acknowledgments** Yaya Idrissou thanks the International Foundation for Science for its financial assistance (IFS, B/6189-1). He also thanks the Intergovernmental Panel on Climate Change (IPCC) and the Prince Albert II of Monaco Foundation (FPAM) for their financial support. The contents of this document are solely the liability of Yaya Idrissou and under no circumstances may be considered as a reflection of the position of the Prince Albert II of Monaco Foundation and/or the IPCC.

---

## References

- Adimassu Z, Kessler A (2016) Factors affecting farmers' coping and adaptation strategies to perceived trends of declining rainfall and crop productivity in the central rift valley of Ethiopia. *Environ Syst Res* 5:13
- Alkoiret IT, Awohouedji DYG, Gbangboche AB, Bosma RH (2010) Productivité des systèmes d'élevage bovin de la commune de Gogounou au nord-est du Bénin. *Ann Sci Agron* 14:145–163



- Alkoiret TI, Radji M, Babatoundé S (2011) Typologie des élevages bovins installés dans la commune de Ouaké au nord-ouest du Bénin. *Livest Res Rural Dev* 23. <http://www.lrrd.org/lrrd23/3/alko23050.htm>
- Apata TG, Samuel KD, Adeola AO (2009) Analysis of climate change perception and adaptation among arable food crop farmers in South Western Nigeria. Contributed paper prepared for presentation at the International Association of Agricultural Economists' 2009 Conference, Beijing, 16–22 Aug 2009
- Ayanlade A, Radeny M, Morton JF (2017) Comparing smallholder farmers' perception of climate change with meteorological data: a case study from southwestern Nigeria. *Weather Clim Extrem* 15:24–33
- Bambara D, Bilgo A, Hien E, Masse D, Thiombiano A, Hien V (2013) Perceptions paysannes des changements climatiques et leurs conséquences socio environnementales à Tougou et Donsin, climats sahélien et sahélo-soudanien du Burkina Faso. *Bull Rech Agron Bénin* 74:8–16
- Bambara D, Thiombiano A, Hien V (2016) Changements climatiques en zones nord-soudanienne et sub-sahélienne du Burkina Faso: comparaison entre savoirs paysans et connaissances scientifiques. *Rev Décologie* 71:35–58
- Calvosa C, Chuluunbaatar D, Fara K (2010) Livestock and climate change. *Livestock Thematic Papers*
- Chapman SC, Chakraborty S, Dreccer MF, Howden SM (2012) Plant adaptation to climate change—opportunities and priorities in breeding. *Crop Pasture Sci* 63:51–268
- Cuni-Sanchez A, Omeny P, Pfeifer M, Olaka L, Mamo MB, Marchant R, Burgess ND (2019) Climate change and pastoralists: perceptions and adaptation in montane Kenya. *Clim Dev* 11:513–524
- Deressa TT, Hassan RM, Ringler C, Alemu T, Yesuf M (2009) Determinants of farmers' choice of adaptation methods to climate change in the Nile Basin of Ethiopia. *Glob Environ Chang* 19:248–255
- Deressa TT, Hassan RM, Ringler C (2011) Perception of and adaptation to climate change by farmers in the Nile basin of Ethiopia. *J Agric Sci* 149:23–31
- Dossa LH, Lesse DP, Houinato M, Sinsin B, Souberou F, Yabi I (2017) Vulnérabilité de l'élevage transhumant à la Variabilité hydro-climatique dans le nord-est de la République du Bénin. *Rev CAMES* 8:233–249
- Foleack DP, Tenikue M (2015) Choice of coping strategies of producers facing the cotton crisis: a multinomial logit analysis in Cameroon. *Int J Innov Appl Stud* 11:77–89
- Gnanglè CP, Glèlè Kakaï R, Assogbadjo AE, Vodounnon S, Afouda Yabi J, Sokpon N (2011) Tendances climatiques passées, modélisation, perceptions et adaptations locales au Bénin. *Climatologie* 8:27–40
- Henry B, Charmley E, Eckard R, Gaughan JB, Hegarty R (2012) Livestock production in a changing climate: adaptation and mitigation research in Australia. *Crop Pasture Sci* 63:191–202
- Idrissou Y, Assani AS, Toukourou Y, Worogo HSS, Assogba BGC, Azalou M, Adjassin JS, Alabi CDA, Yabi JA, Alkoiret IT (2019) Systèmes d'élevage pastoraux et changement climatique en Afrique de l'Ouest: Etat des lieux et perspectives. *Livest Res Rural Dev* 31. <http://www.lrrd.org/lrrd31/8/yadris31118.html>
- Idrissou Y, Assani Seidou A, Tossou MF, Baco MN, Sanni Worogo HS, Adjassin JS, Assogba BGC, Alkoiret Traoré I (2020) Perception du changement climatique par les éleveurs de bovins des zones tropicales sèche et subhumide du Bénin: Comparaison avec les données météorologiques. *Cah Agric* 29:9. <https://doi.org/10.1051/cagri/2019032>
- IUCN (2010) Building climate change resilience for African livestock in sub-Saharan Africa – World Initiative for Sustainable Pastoralism, (WISP): a program of IUCN – The International Union for Conservation of Nature, Eastern and Southern Africa Regional Office, Nairobi, Mar 2010
- Kaboré PN, Barbier B, Ouoba P, Kiema A, Some L, Ouedraogo A (2019) Perceptions du changement climatique, impacts environnementaux et stratégies endogènes d'adaptation par

- les producteurs du Centre-nord du Burkina Faso. *Vertigo*- Rev Électronique En Sci Environ 19. <https://doi.org/10.4000/vertigo.24637>
- Kiema A, Some L, Nacro BH, Compaore H, Kagone H, Kpoda CY, Bambara GT (2013) Stratégies d'adaptation des éleveurs de la zone Est du Burkina Faso aux effets des changements climatiques. *Agron Afr* 6:67–79
- Kima SA, Okhimamhe AA, Kiema A, Zampaligre N, Sule I (2015) Adapting to the impacts of climate change in the sub-humid zone of Burkina Faso, West Africa: perceptions of agro-pastoralists. *Pastoralism* 5:16
- Kosmowski F, Leblois A, Sultan B (2016) Perceptions of recent rainfall changes in Niger: a comparison between climate-sensitive and non-climate sensitive households. *Clim Chang* 135:227–241
- Limantol AM, Keith BE, Azabre BA, Lennartz B (2016) Farmers' perception and adaptation practice to climate variability and change: a case study of the Vea catchment in Ghana. *Springerplus* 5:830
- Mabe FN, Sienso G, Donkoh S (2014) Determinants of choice of climate change adaptation strategies in northern Ghana. *Res Appl Econ* 6:75–94
- Mamba SF (2016) Factors influencing perception of climate variability and change among small-holder farmers in Swaziland. *Indian J Nutr* 3:138
- McDonald JH (2009) *Handbook of biological statistics*. Sparky House Publishing, Baltimore
- MEHU (2011) *Deuxième Communication Nationale de la République du Bénin sur les Changements Climatiques*. Cotonou Ministère L'Environnement L'Habitat L'Urbanisme
- Nardone A, Ronchi B, Lacetera N, Ranieri MS, Bernabucci U (2010) Effects of climate changes on animal production and sustainability of livestock systems. *Livest Sci* 130:57–69. <https://doi.org/10.1016/j.livsci.2010.02.011>
- Opiyo F, Wasonga OV, Nyangito MM, Mureithi SM, Obando J, Munang R (2016) Determinants of perceptions of climate change and adaptation among Turkana pastoralists in northwestern Kenya. *Clim Dev* 8:179–189
- Oyekale AS (2014) Impacts of climate change on livestock husbandry and adaptation options in the arid Sahel belt of West Africa: evidence from a baseline survey. *Asian J Anim Vet Adv* 9:13–26
- Polley HW, Briske DD, Morgan JA, Wolter K, Bailey DW, Brown JR (2013) Climate change and North American rangelands: trends, projections, and implications. *Rangel Ecol Manag* 66:493–511
- Salack S, Muller B, Gaye AT, Hourdin F, Cisse N (2012) Multi-scale analyses of dry spells across Niger and Senegal. *Sécheresse* 23:3–13
- Sanfo A, Sawadogo I, Kulo EA, Zampaligre N (2015) Perceptions and adaptation measures of crop farmers and agropastoralists in the eastern and plateau central regions of Burkina Faso, West Africa. *FIRE J Sci Technol* 3:286–298
- Sanogo K, Binam J, Bayala J, Villamor GB, Kalinganire A, Dodiomon S (2017) Farmers' perceptions of climate change impacts on ecosystem services delivery of parklands in southern Mali. *Agrofor Syst* 91:345–361
- Sanou CL, Tsado DN, Kiema A, Eichie JO, Okhimamhe AA (2018) Climate variability adaptation strategies: challenges to livestock mobility in south-eastern Burkina Faso. *Open Access Libr J* 5:1–17
- Sautier M (2013) *Outiller l'adaptation des élevages herbagers au changement climatique: de l'analyse de la vulnérabilité à la conception participative de systèmes d'élevage*. Thèse de doctorat, Université de Toulouse
- Uddin MN, Bokelmann W, Dunn ES (2017) Determinants of farmers' perception of climate change: a case study from the coastal region of Bangladesh. *Am J Clim Chang* 6:151
- Zakari S, Tente BAH, Yabi I, Imorou IT, Tabou T, Afouda F, N'Bessa B (2015) Vulnérabilité des troupeaux transhumants aux mutations climatiques: analyse des perceptions et adaptations locales dans le bassin de la Sota à Malanville. *Afr Sci Res Int Sci Technol* 11:211–228
- Zampaligré N, Dossa LH, Schlecht E (2014) Climate change and variability: perception and adaptation strategies of pastoralists and agro-pastoralists across different zones of Burkina Faso. *Reg Environ Chang* 14:769–783
- Zhang X, Yang F (2004) *RCLimDex 10 user manual climate research branch Environment Canada*

**Open Access** This chapter is licensed under the terms of the Creative Commons Attribution 4.0 International License (<http://creativecommons.org/licenses/by/4.0/>), which permits use, sharing, adaptation, distribution and reproduction in any medium or format, as long as you give appropriate credit to the original author(s) and the source, provide a link to the Creative Commons license and indicate if changes were made.

The images or other third party material in this chapter are included in the chapter's Creative Commons license, unless indicated otherwise in a credit line to the material. If material is not included in the chapter's Creative Commons license and your intended use is not permitted by statutory regulation or exceeds the permitted use, you will need to obtain permission directly from the copyright holder.





# Drivers of Level of Adaptation to Climate Change in Smallholder Farming Systems in Southern Africa: A Multilevel Modeling Approach

# 12

Byron Zamasiya, Kefasi Nyikahadzoi, and Billy Billiard Mukamuri

## Contents

Introduction and Background .....	214
Data Gathering and Analytical Framework .....	216
Multilevel Estimation of Determinants of Level of Adaptation .....	217
Random Effects .....	217
Hierarchical Linear Regression Model with Random Intercept and Level 2 Covariates .....	219
Promote Learning Through Linkages with Public and Private Extension Services .....	222
References .....	222

## Abstract

Climate change is a major development challenge affecting developing countries that rely on rain-fed agricultural production for food and income. Smallholder farmers in these countries are using multiple adaptation practices to manage the effects of climate change. This chapter examines household and community-level factors that influence smallholder farmers' level of adaptation to climate change in the Hwedza District in Zimbabwe. Data for this study were collected from 400 randomly selected smallholder farmers, using a structured questionnaire, focus group discussions, and key informant interviews. The study used a multilevel modeling approach to examine the factors that influence smallholder farmers' level of adaptation to climate change. Results from the study show that smallholder farmers' level of adaptation to climate change is conditioned by access to extension services, access to remittances, family labor, household education

This chapter was previously published non-open access with exclusive rights reserved by the Publisher. It has been changed retrospectively to open access under a CC BY 4.0 license and the copyright holder is "The Author(s)". For further details, please see the license information at the end of the chapter.

B. Zamasiya (✉) · K. Nyikahadzoi · B. B. Mukamuri  
Centre for Applied Social Sciences, University of Zimbabwe, Harare, Zimbabwe  
e-mail: [bzamasiya@gmail.com](mailto:bzamasiya@gmail.com); [knyika@gmail.com](mailto:knyika@gmail.com); [bmukamuri@gmail.com](mailto:bmukamuri@gmail.com)

(household level factors), and linking capital (community-level factor). This chapter therefore concludes that smallholder farmers that have higher levels of adaptation to climate change are those that are well linked to external organizations and have access to agricultural extension services. The chapter recommends that adaptation to climate change can be enhanced by improving access to agricultural extension services and promoting linkages with external organizations that provide information on agricultural adaptation practices.

---

**Keywords**

Level of adaptation · Climate change · Smallholder farmers · Hierarchical linear modeling · Linking capital

---

## Introduction and Background

Climate change is a major development challenge facing developing countries particularly those in Southern Africa (Ali and Erenstein 2017; IPCC 2014). These countries are battling to address multiple stressors that include a high incidence of poverty, chronic food insecurity, malnutrition, HIV, lack of disaster preparedness, political upheavals, and macroeconomic instability (Adego et al. 2018). In this region, rain-fed agriculture which accounts for 95% of agricultural production provides livelihoods to over 70% of the population (Zamasiya and Nyikahadzoi 2018; Asfaw et al. 2016). Overreliance on climate-sensitive agricultural systems exacerbates the vulnerability of countries in Southern Africa such as Zimbabwe (Rurinda et al. 2013). Rainfall is the major determinant of agricultural production. Reports show that the mean annual rainfall has already declined by over 5% and forecasted to further decrease by 10%. The IPCC's 2018 report notes that with business as usual approach to greenhouse emissions, temperatures will increase by over 1.5 °C. The consequences of such an increase will be catastrophic to resource-constrained smallholder farmers in Southern Africa particularly those with low adaptive capacity. This development will plunge developing countries into dire food insecurity and chronic malnutrition. These conditions require that smallholder farmers who are the major food producers adapt to climate change (Abid et al. 2015; Mabe et al. 2012). Adaptation, in this case, is the use of farming practices that can reduce the impact of climate change on smallholder farmers' food security.

Scholars observe that adaptation reduces the impacts of climate change on food security systems (Adego et al. 2018; Shisanya and Mafongoya 2016; Di Falco et al. 2011). Some of the adaptation practices that smallholder farmers are to manage the impacts of climate change include crop diversification, drought-tolerant varieties, income diversification, staggering of planting dates, crop mixing, and soil and water conservation (Adego et al. 2018; Shisanya and Mafongoya 2016; Nyikahadzoi et al. 2017). Studies show that some smallholder farmers use more than one adaptation practices. In such circumstances, such smallholder farmers are likely to have better food security than those that use solitary adaptation practices. Although adaptation is

a viable response to climate change, smallholder farmers face challenges in implementing the adaptation practices. These challenges include lack of access to climate information, lack of access to agricultural credit, lack of access to an extension to adequately prepare for seasons, lack of knowledge on adaptation practices, and lack of labor resources (Nyikahadzoi et al. 2017; Salau et al. 2012; Di Falco et al. 2011). Since adaptation differs by contexts, some of the adaptation practices may not be applicable in other regions.

There are very limited studies (Ali and Erenstein 2017; Below et al. 2012) on drivers of the level of adaptation to climate change by smallholders. While the limited studies that are there provide important insights on determinants of the level of adaptation among smallholder farmers, their major challenge is that they used simplistic modeling techniques. These techniques do not recognize the nesting of data in groups and may, therefore, lead to biased results and poor policy targeting. This chapter recognizes that since farmers are nested in villages and villages are nested in wards, the actions of individual smallholder farmers are a function of household socioeconomic level and community-level variables. This is because smallholder farmers live in an open environment in which they interact among themselves, interact with people from other wards, and interact with external organizations. The levels of interaction vary from village to village, and this necessitates the use of multilevel modeling techniques (Frankenberger et al. 2013). The chapter proposes the use of the hierarchical linear modeling technique to examine the drivers of the level of adaptation to climate change among smallholders' farmers in the Hwedza District of Zimbabwe. This model addresses the weaknesses of confounding that are inherent in models used in previous studies.

In some of the studies on drivers of the level of adaptation to climate change, social capital was used as an explanatory variable. The definition used for social capital is restricted to farmer-farmer interactions at a local level such as within a village. This definition does not capture vertical interactions between communities and organizations that are external to the community. In this study, a deliberate attempt is made to distinguish between social capitals. The chapter adopts the categorization of social capital proposed by Aldrich (2012) and Frankenberger et al. (2013) which provides a clear distinction between bonding capital, bridging capital and linking capital. In this study, our concern is on linking social capital. It refers to the linkages between communities and organizations that are external to it. Scholars argue that communities that have better resilience are those that have higher linking social capital compared to bonding capital (Aldrich 2012; Taruvinga et al. 2017). This chapter measures linking capital as a village-level variable and use it as a level 2 covariate in the hierarchical linear regression model.

Given the inevitability of climate change, adequately preparing for this eventuality requires policymakers to understand the drivers of the level of current adaptation practices to climate change by smallholders. The purpose of this chapter is to improve policymakers' understanding of the determinants of smallholder farmers' level of adaptation to climate change. The issue of determinants of the level of adaptation to climate change among smallholder farmers is poorly understood and measured. In this study, the level of adaptation to climate change is the number of

strategies that are used by a smallholder farmer in response to climate change. This chapter, therefore, seeks to provide empirical evidence on what drives the level of adaptation. This information is critical for identifying and setting policy targets for enhancing adaptation. Without that, it is difficult for policymakers to enhance current and future adaptation by smallholder farmers.

---

## Data Gathering and Analytical Framework

This study was conducted in Hwedza District in Mashonaland East Province of Zimbabwe is a “climate hotspot.” Zimbabwe is divided into five agro-ecological regions known as natural regions (NR). This classification is based on the soil quality, rainfall regime, and vegetation distribution. The quality of the land resource declines from natural region (NR) I through to NR V. Hwedza District is located in natural region II with an annual rainfall of 650–800 mm and a mean temperature of 29 °C (Rurinda et al. 2013). The predominant soil type is coarse sandy soils derived from granitic rocks (Rurinda et al. 2014). Average household farm sizes range between 2 and 5 ha per household (Rurinda et al. 2014). Hwedza District is a communal area dominated by subsistence maize production for food security. The subsistence farmers also grow groundnuts, finger millet, and cowpeas on small plots (Zamasiya et al. 2018). Crop production is complemented with livestock rearing mostly cattle, goats, and indigenous chickens. During poor cropping seasons, smallholder farmers in the district rely on non-timber forest products for food (Woittiez et al. 2013) and food aid from nongovernmental organizations (NGO). Due to climate change, the onset and distribution of rainfall in the Hwedza District are now very unpredictable. The district experiences frequent midseason droughts with good rainfall years increasingly becoming fewer over the past 20 years (Rurinda et al. 2014). Smallholder farmers in this district use different farming practices to manage the effects of climate change. These practices include crop diversification, staggering of planting dates, soil and water conservation practices, drought-tolerant varieties, integrated soil fertility management, and crop mixing (Zamasiya et al. 2017). Public and private research organizations and nongovernmental organizations were promoting a basket of ex ante climate adaptation practices to improve smallholder farmers’ preparedness to droughts and increased rainfall variability.

The study used a multistage sampling technique to select the study site and the survey respondents. The target population in this study are smallholder farmers practicing crop and/or livestock farming in Hwedza District in Zimbabwe. In stage one, purposive sampling was used to select the Hwedza District in Mashonaland East Province of Zimbabwe. This study site was selected on the basis that it has a high agro-ecological potential and has experienced an increase in extreme climatic events since the year 2000. In stage two, random sampling was used to select Ushe and Dendenyore wards from a total of 22 wards in the district. In stage 3, simple random sampling was used to select 10 villages per ward. Dendenyore ward has 30 villages, and the Ushe ward has 22 villages. In the last stage, the study used simple random sampling to select 20 households in each village. In total, 400 smallholder farmers were interviewed during the survey in February 2015.

Quantitative and qualitative data used in this study was solicited from smallholder farmers using a structured questionnaire, focus group discussions (FGDs) and key informant interviews. The structured questionnaire collected data on demographic information, strategies used by smallholder farmers to respond to climate change, access to extension, remittances, and challenges experienced by farmers in adapting to climate change. The key informant interviews were conducted with ward level agricultural extension officers (AEOs) and district level extension officers. In total, eight AEOs participated in the key informant interviews. The study also collected data from knowledgeable smallholder farmers. A total of six farmers participated in the key informant interviews. Knowledgeable farmers are smallholders who have at least 30 years of conducting farming activities in the Hwedza district. Purposive sampling was used to select participants for the key informant interviews. Focus group discussions were conducted with smallholder farmers in each village. Each FGD had 12 smallholder farmers (6 males and 6 females). The purpose of FGDs in each village was to get an average rating of the village's perception of the level of linking the capital, the farming practices used by smallholder farmers, and the challenges that they are experiencing in adapting.

Quantitative data analysis was done in STATA Version 15. This study used a multilevel modeling technique that is known as the hierarchical linear modeling (HLM) to establish the determinants of farmers' level of adaptation to climate change. An HLM technique is a random coefficient modeling approach that can be used to analyze data that is nested within groups (Huta 2014). Such models are used to examine how individual-level relationships vary as a function of group characteristics (Hox et al. 2018). The HLM estimation procedures are capable of analyzing nested data (Huta 2014). The results from this analysis are presented in tables as coefficients. This study used a level 2 HLM approach comprising household-level variables for individual farmers and group level variables. Qualitative data collected from interviews and focus group discussions and observations were analyzed thematically.

---

## Multilevel Estimation of Determinants of Level of Adaptation

This chapter presents the results from the determinants of the level of adaptation to climate change among smallholder farmers in Zimbabwe.

The first stage is to run the random effects model. The purpose of doing this is to understand the portion of variance that is due to cross-village interactions compared to individual household interactions. This model can be written as follows:

### Random Effects

Results in Table 1 show that there are 400 level 1 units (number of observations) in the analysis and 20 level 2 units (number of villages/groups). The cluster size varies from 14 to 28 with a mean cluster size of 20. The log-likelihood ratio is  $-797, 1447$ . The grand mean across the villages is 1.5066 with a standard error of 0.1640. The z



**Table 1** Estimation results for a random effects model

LOA	Coef.	Std. Err.	Z	P > z	[95% Conf.	Interval]
_cons	1.5066	0.1640	9.1900	0.0000	1.1851	1.8281
Random effects parameters		Estimate	Std. Err.	[95% Conf. Interval]		
village: Identity						
var(_cons)		0.3868	0.1723	0.1615	0.9263	
var(Residual)		2.9565	0.2146	2.5644	3.4085	

LR test versus linear model:  $\chi^2(01) = 22.5800$  Prob  $\geq \chi^2 = 0.0000$

**Table 2** Estimation results for a random intercept model

Adaptation (Adj)	Coef.	Std. Err.	z	P > z	[95% Conf.	Interval]
Visitextn	1.1785	0.2022	5.8300	0.0000***	0.7822	1.5748
FamilyRemit	0.7180	0.2262	3.1700	0.0020***	0.2747	1.1612
Farmlabor	0.1669	0.0433	3.8500	0.0000***	0.0819	0.2518
Hheducation	0.0533	0.0316	1.6900	0.0920*	-0.0087	0.1152
_cons	0.3953	0.2588	1.5300	0.1270	-0.1119	0.9025
Random effects parameters		Estimate	Std. Err.	[95% Conf. Interval]		
village: Identity						
var(_cons)		0.2390	0.1193	0.0898	0.6360	
var(Residual)		2.6064	0.1892	2.2608	3.0049	

Wald  $\chi^2(4) = 59.92$ ; Prob  $> \chi^2 = 0.0000$ ; LR test versus linear model:  $\chi^2(01) = 13.61$  Prob  $\geq \chi^2 = 0.0001$

statistic is 9.1900, and the p-value is 0.000. The reported LR test statistic is 22.5800 with a p-value of 0.000; we, therefore, reject the null hypothesis that  $\tau_0$  is equal to zero. It, therefore, means that there is intervillage variation in the adaptation by smallholder farmers. Based on the output, the interclass correlation is 11.57%. This means that 11.57% of the variation in adaptation among smallholder farmers in Hwedza district is due to differences across villages and 88.43% is due to individual differences across farmers.

The random intercept model involves the addition of level 1 covariates to the model, but it assumes fixed effects. In this stage, the intercept is allowed to vary across villages to accommodate intervillage variations. The model can be expressed as follows:

Table 2 shows the estimation results of the random intercept model. The results show that all the independent variables have positive effects on adaptation. They are all statistically significant with Visitextn ( $p < 1\%$ ), FamilyRemit ( $p < 1\%$ ), Farmlabor ( $p < 1\%$ ), and Hheducation ( $p < 10\%$ ). The Wald test shows that  $W = 59.92$  and  $p\text{-value} = 0.0000$ . Comparing the fit of the random intercept model and the LR = 13.61 and a  $p\text{-value}$  of 0.0001. Therefore, the null hypothesis that the intercept is the same across all villages is rejected.

## Hierarchical Linear Regression Model with Random Intercept and Level 2 Covariates

This model seeks to account for the variation in intercepts across villages. This is done by adding a level two covariate.

Table 3 shows the results of the hierarchical linear regression model with random intercept and a village-level covariate. The results show that Level 1 covariates are all significant. The level 2 covariate (linking social capital) is also very significant ( $p < 1\%$ ). The Wald test statistic  $W = 100.55$  has a  $p$ -value of 0.000. The results show that the second level variable linking social capital improves the level of adaptation for smallholder farmers.

This chapter presents the discussion from the study. The discussion is based on theoretical and empirical evidence to recommend how government and organizations external to the community can help in improving adaptation to climate change by smallholder farmers. Based on this study, the variables that can be influenced to promote adaptation are access to agricultural extension services, access to remittances, family labor, level of education, and linking social capital.

The coefficient of access to agricultural extension services ( $p < 1\%$ ) is statistically significant and positively influences smallholder farmers' level of adaptation to climate change. Extension officers play a pivotal role in the dissemination of agricultural adaptation technologies (Zamasiya and Nyikahadzo 2018; Zamasiya et al. 2014). Through field-based demonstrations and awareness meetings, extension officers help in disseminating information to smallholder farmers on adaptation practices that they can use to manage the impacts of climate change on food security (Zamasiya et al. 2017; Ali and Erenstein 2017). Smallholder farmers who have access to AEOs are more likely to know different adaptation practices. As such they are more likely to have higher levels of adaptation to climate change than their counterparts. However, key informants highlighted that the major challenge facing AEOs in Zimbabwe is lack of motorcycles for improving mobility and contact with

**Table 3** Estimation results for HLM with random intercept and level 2 covariates

LOA	Coef.	Std. Err.	Z	P > z	[95% Conf. Interval]	
Extension	1.0950	0.1995	5.4900	0.0000	0.7040	1.4859
FamilyRemit	0.6645	0.2234	2.9700	0.0030	0.2267	1.1022
FarmLabor	0.1574	0.0428	3.6700	0.0000	0.0735	0.2414
Heducation	0.0554	0.0312	1.7800	0.0760	-0.0057	0.1165
Linking	2.1973	0.4137	5.3100	0.0000	1.3865	3.0081
_cons	-0.4074	0.2734	-1.4900	0.1360	-0.9433	0.1286
Random effects parameters		Estimate	Std. Err.	[95% Conf. Interval]		
village: Identity						
var(_cons)		0.0216	0.0493	0.0002	1.8808	
var(Residual)		2.6050	0.1890	2.2597	3.0031	

Wald  $\chi^2(5) = 100.55$ ; Prob >  $\chi^2 = 0.0000$ ; LR test versus linear model:  $\text{chibar2}(01) = 0.23$   
 Prob  $\geq \text{chibar2} = 0.3150$

smallholder farmers. The wards in Hwedza District are so big that it becomes difficult for the AEOs to effectively contact farmers if they are not motorized. Other AEOs highlighted that they have motorcycles but have no access to fuel. This, therefore, makes it difficult for them to dispatch their roles efficiently. During FGDs, smallholder farmers highlighted that the challenge with AEOs is that climate change is a new phenomenon to them. They were advising farmers based on their lived realities. These results corroborate with the findings of Zamasiya et al. (2018), and Ali and Erenstein (2017).

Results show that the coefficient of access to remittances ( $p < 1\%$ ) is very statistically significant and positively improves a smallholder farmer's level of adaptation to climate change. Remittances improve the number of financial resources that are available to a household (Nyikahadzoi et al. 2013) for purposes of financing transaction costs associated with adaptation to climate change. These costs could include the cost of improved seed, inorganic fertilizers, and herbicides. Zamasiya et al. (2018) note that smallholder farmers with access to remittances are more likely to adapt than their counterparts. They further highlight that some smallholder farmers rely on disposing of small livestock to finance adaptation costs. This is the case in economies such as Zimbabwe where most smallholder farmers have no access to formal banking systems (Nyikahadzoi et al. 2012). With improved access to financial resources, it is more likely that the smallholder farmers will improve their levels of adaptation. During FGDs, smallholder farmers highlighted that their major challenge is lack of agricultural credit. They mentioned that the lack of access to financial resources limited their ability to implement several adaptation practices. For instance, some farmers highlighted that they lacked financial resources to purchase improved seeds, inorganic fertilizers, and herbicides, and this made it difficult to implement several adaptation practices. Some of the smallholder farmers ended up planting recycled maize seeds. Key informants highlighted that when smallholder farmers used recycled seed, they used the wrong seed rate for maize crop. The key informants also highlighted that in most cases, agro-dealers sell only one variety of maize seeds. The smallholder farmers just end up buying the available seed. These results corroborate with the findings of Ali and Erenstein (2017).

Study findings show that the coefficient of family labor positive and statistically significant ( $p < 1\%$ ) influences a smallholder farmer's level of adaptation to climate change. Labor is a major constraint to adaptation among smallholder farmers (Deressa et al. 2010). The family offers technical and manual skills that are crucial for executing agronomic practices on time. Smallholder farming households that have large pools of labor can spread labor resources across different adaptation practices. Such households can utilize labor-intensive practices such as crop diversification and soil and water conservation practices (Zamasiya et al. 2018). As such, households with higher labor resources are more likely to have higher levels of adaptation than their counterparts. These results corroborate with the findings of Ali and Erenstein (2017).

Research findings show that the coefficient of level of education ( $p < 10\%$ ) is marginally statistically significant and positively influences a smallholder farmers' level of adaptation to climate change. Zamasiya et al. (2018) note that education

improves a smallholder farmer's ability to receive, decode, and use the information on adaptation practices. These results suggest that smallholder farmers who are educated are more likely to be aware of climate change, the adaptation practices that they can use, and the benefits of adaptation. It is therefore likely that such smallholder farmers are more likely to have higher levels of adaptation to climate change than their counterparts. During FGDs, it was observed that most educated smallholder farmers were aware of adaptation practices and were proactively seeking more information on the practices from extension officers. Key informants highlighted that educated farmers were willing to experiment with new adaptation practices than uneducated smallholder farmers. Key informants highlighted that the lack of education among smallholder farmers is a major constraint to adaptation. Results corroborate with the findings of Below et al. (2012) and Ali and Erenstein (2017).

Study findings show that the coefficient of linking capital ( $p < 1\%$ ) is very statistically significant and positively influences the level of adaptation to climate change. Linking social capital is an important driver of the level of adaptation to climate change by smallholder farmers. As observed by Aldrich (2012), linking capital improves adaptation through the provision of information that is otherwise unavailable. Through vertical relations with organizations external to the community, linking social capital improves access to information that is very important for enhancing adaptation to climate change (Taruvunga et al. 2017; Babaei et al. 2012). Information that communities may access through linking social capital includes improved varieties, yield robustness of such varieties, baskets of adaptation technologies, research results, and opportunities for exchange visits. In the study site, the communities are linked to research institutions that conduct farmer-managed and researcher-managed experiments. The smallholder farmers participate in field days where they get to interact with staff from organizations that play a key role in the agricultural value chain. Through these platforms, smallholder farmers have access to valuable agronomic information that they use for enhancing their adaptation to climate change. During FGDs, smallholder farmers highlighted that external organizations played a pivotal role in the dissemination of information on adaptation practices. The smallholder farmers noted that they were now aware of new crop varieties, their performance under different management regimes, and had acquired invaluable knowledge on different adaptation practices. Key informants highlighted that financial resources were scarce for the Agritex Department. As such, access to linking capital is associated with higher levels of adaptation to climate change.

This chapter sought to understand the determinants of the level of adaptation among smallholder farmers in Southern Africa using the example of the Hwedza district in Zimbabwe. The study used the multilevel modeling approach. Results show that level of education, access to agricultural extension, family labor, and access to remittances positively influence the level of adaptation. At a community level, adaptation is influenced by access to linking social capital. We, therefore, conclude that smallholder farmers that have a high level of adaptation to climate change are those that are well linked to external organizations and have access to extension services and financial resources.

## Promote Learning Through Linkages with Public and Private Extension Services

Based on the results from this study, the chapter recommends that to improve smallholder farmers' level of adaptation to climate change, there is a need to enhance access to agricultural extension services and NGOs or research organizations. Because the mobility of extension staff is a recurrent problem in most areas, the public extension should establish linkages with other extension service providers in their area such as NGOs and private companies so that they can combine their programs. This will ease the mobility challenges. Further, government can also boost extension service delivery through timely recruitment, periodic training of the agents, and provision of adequate logistical support. The role of organizations that are external to the smallholder farming communities cannot be underestimated. These institutions provide a feedback loop between grassroots and policymakers. They gather critical information on climate change technologies and disseminate it to smallholder farmers. For instance, NGOs and research organizations have pioneered agricultural technologies and trainings that have since been incorporated into the public extension system. To promote development of linking capital, policymakers need to adopt participatory and inclusive decision-making processes in their work with communities, encourage smallholder farmers to work in groups, promote look and learn tours to other communities to challenge, inspire, and educate communities. This will improve access to critical information on agricultural technologies that are useful for enhancing smallholder adaptation to climate change.

**Acknowledgments** The authors would like to thank the International Foundation for Science who provided funding for this research through Grant No. S/5158-1.

---

## References

- Abid M, Scheffran J, Schneider U, Ashfaq (2015) Farmers' perceptions of and adaptation strategies to climate change and their determinants: the case of Punjab province, Pakistan. *Earth Syst Dyn* 6:225
- Adego T, Simane B, Woldie G (2018) The impact of adaptation practices on crop productivity in Northwest Ethiopia: an endogenous switching estimation. *Dev Stud Res* 6(1):129–141
- Aldrich DP (2012) Building resilience: social capital in post-disaster recovery. University of Chicago Press, Chicago
- Ali A, Erenstein O (2017) Assessing farmer use of climate change adaptation practices and impacts on food security and poverty in Pakistan. *Clim Risk Manag* 16:183–194
- Asfaw S, Di Battista F, Lipper L (2016) Agricultural technology adoption under climate change in the Sahel: micro-evidence from Niger. *J Afr Econ* 25(5):637–669
- Babaei H, Gill S, Ahmad N (2012) Bonding, bridging and linking social capital and psychological empowerment among squatter settlements in Tehran, Iran. *J Basic Appl Sci Res* 2(2):109–115
- Below TB, Mutabazi KD, Kirschke D, Franke C, Sieber S, Siebert R, Tscherning K (2012) Can farmers' adaptation to climate change be explained by socio-economic household-level variables? *Glob Environ Chang* 22(1):223–235

- Deressa T, Hassan R, Ringler C (2010) Perception and adaptation to climate change: the case of farmers in the Nile Basin of Ethiopia. *J Agric Sci* 149:23–31
- Di Falco S, Veronesi M, Yesuf M (2011) Does adaptation to climate change provide food security? A micro-perspective from Ethiopia. *Am J Agr Econ* 93(3):829–846
- Frankenberger T, Mueller M, Spangler T, Alexander S (2013) Community resilience: conceptual framework and measurement feed the future learning agenda. Westat: United States Agency for International Development (USAID), Rockville
- Hox J, Moerbeek M, van de Schoot R (2018) The basic two-level regression model. In: *Multilevel analysis. Techniques and applications*. Routledge, New York
- Huta V (2014) When to use hierarchical linear modeling. *Tutor Quant Methods Psychol* 10 (1):13–28
- IPCC (2014) *Climate Change 2014: Synthesis Report. Contribution of Working Groups I, II and III to the Fifth Assessment Report of the Intergovernmental Panel on Climate Change* [Core Writing Team, RK Pachauri and LA Meyer (eds)]. IPCC, Geneva, Switzerland, 151 pp
- Mabe F, Sarpong D, Osei-Asare Y (2012) Adaptive capacities of farmers to climate change adaptation strategies and their effects on rice production in the Northern Region of Ghana. *Russ J Agric Socio-Econ Sci* 11(11):9–17
- Nyikahadzoi K, Siziba S, Mango N, Mapfumo P, Adekunle A, Oluwole F (2012) Creating food self-reliance among the smallholder farmers of eastern Zimbabwe: exploring the role of integrated agricultural research for development. *J Food Secur* 4:647–656
- Nyikahadzoi K, Zamasiya B, Muchinako G, Dziro C (2013) Enhancing social support system for improving food security among the elderly headed household in communal areas of Zimbabwe. *J Food Res* 2(3):46–54
- Nyikahadzoi K, Mombo O, Zamasiya B, Warinda P (2017) Enhancing household food security under changing climatic conditions: a case study of Gokwe North and Hurungwe Districts in Zimbabwe. *J Agric Food Inf* 18(2):96–109
- Rurinda J, Mapfumo P, van Wijk MT, Mtambanengwe F, Rufino MC, Chikowo R, Giller KE (2013) Managing soil fertility to adapt to rainfall variability in smallholder cropping systems in Zimbabwe. *Field Crop Res* 154:211–225
- Rurinda J, Mapfumo P, van Wijk M, Mtambanengwe F, Rufino M, Chikowo R, Giller K (2014) Sources of vulnerability to a variable and changing climate among smallholder households in Zimbabwe: a participatory analysis. *Clim Risk Manag* 3:65–78
- Salau ES, Onuk EG, Ibrahim A (2012) A micro-econometric analysis of adapting portfolios to climate change: adoption of agricultural systems in Latin America. *J Agric Ext* 16(2):199–211
- Shisanya S, Mafongoya P (2016) Adaptation to climate change and the impacts on household food security among rural farmers in uMzinyathi District of Kwazulu-Natal, South Africa. *Food Secur* 8:597–608
- Taruvunga B, Ndou P, Hlerema I, Maraganedza T, Du Plooy P, Venter S (2017) Fostering linking social capital for successful agricultural development projects in South Africa. *Agrekon* 56(1):28–39
- Woittiez LS, Rufino MC, Giller KE, Mapfumo P (2013) The use of woodland products to cope with climate variability in communal areas in Zimbabwe. *Ecol Soc* 18(4):24
- Zamasiya B, Nyikahadzoi K (2018) Intensification of soybean cultivation by smallholders: opportunities and constraints. In: Nguyen H (ed) *Special issue on cultivation of soybeans*, vol 1. Burleigh Dodds Science Publication, Cambridge, UK, pp 305–316
- Zamasiya B, Mango N, Nyikahadzoi K, Siziba S (2014) Determinants of soybean market participation by smallholder farmers in Zimbabwe. *J Dev Agric Econ* 6(2):49–58
- Zamasiya B, Nyikahadzoi K, Mukamuri BB (2017) Factors influencing smallholder farmers' behavioral intention towards adaptation to climate change in transitional climatic zones: a case study of Hwedza District in Zimbabwe. *J Environ Manag* 198:233–239
- Zamasiya B, Nyikahadzoi K, Mukamuri B (2018) Drivers of adaptation to climate change by smallholder farmers residing in Zimbabwe's communal areas: a case study of Hwedza District in Zimbabwe. *Zambezia J Human* 45(ii):75–92

**Open Access** This chapter is licensed under the terms of the Creative Commons Attribution 4.0 International License (<http://creativecommons.org/licenses/by/4.0/>), which permits use, sharing, adaptation, distribution and reproduction in any medium or format, as long as you give appropriate credit to the original author(s) and the source, provide a link to the Creative Commons license and indicate if changes were made.

The images or other third party material in this chapter are included in the chapter's Creative Commons license, unless indicated otherwise in a credit line to the material. If material is not included in the chapter's Creative Commons license and your intended use is not permitted by statutory regulation or exceeds the permitted use, you will need to obtain permission directly from the copyright holder.





# Economic Analysis of Climate-Smart Agriculture Technologies in Maize Production in Smallholder Farming Systems

# 13

Angeline Mujeyi and Maxwell Mudhara

## Contents

Introduction .....	226
CSA in Crop-Livestock Farming Systems .....	228
Methodology .....	228
Study Area and Data Collection .....	228
Data Analysis .....	229
Results and Discussion .....	233
CSA Adaptation Strategies Employed by Households in Maize Production .....	233
Economic Analysis of Maize .....	235
Estimated Stochastic Frontier Profit Function .....	236
Conclusions and Recommendations .....	237
References .....	238

## Abstract

Smallholder farmers who grow the staple maize crop rely mainly on rain-fed agricultural production, and yields are estimated to have decreased by over 50% largely due to climate change. Climate-smart agriculture (CSA) technologies, as adaptive strategies, are thus increasingly being promoted to overcome problems of declining agricultural productivity and reduced technical efficiency. This study analyzed profitability and profit efficiency in maize (*Zea mays*) production as a result of CSA technology adoption using cost-benefit analysis and stochastic profit frontier model. The study used data from a

This chapter was previously published non-open access with exclusive rights reserved by the Publisher. It has been changed retrospectively to open access under a CC BY 4.0 license and the copyright holder is “The Author(s)”. For further details, please see the license information at the end of the chapter.

A. Mujeyi (✉) · M. Mudhara

College of Agricultural, Engineering and Science, Discipline of Agricultural Economics, University of KwaZulu-Natal, Scottsville, Pietermaritzburg, South Africa

e-mail: [Mudhara@ukzn.ac.za](mailto:Mudhara@ukzn.ac.za)

© The Author(s) 2021

W. Leal Filho et al. (eds.), *African Handbook of Climate Change Adaptation*,  
[https://doi.org/10.1007/978-3-030-45106-6\\_17](https://doi.org/10.1007/978-3-030-45106-6_17)

225



cross-sectional household survey of 386 households drawn from 4 districts in Mashonaland *East* province located in the northeastern part of *Zimbabwe*. Results from the cost-benefit analysis reveal that maize performs best under CSA technologies. The profit inefficiency model shows that extension contact, number of local traders, and adoption of CSA had significant negative coefficients indicating that as these variables increase, profit efficiency among maize-growing farmers increases. This implies that profit inefficiency in maize production can be reduced significantly with improvement in extension contact, access to farm gate/local markets, and adoption of CSA. The findings call for development practitioners to incorporate market linkages that bring buyers closer to the farmers, support for extension to be able to have frequent contacts with farmers, and promotion of CSA adoption.

---

**Keywords**

Cost-benefit analysis · Return on investment · Profit efficiency · Stochastic frontier · Zimbabwe

---

**Introduction**

Maize (*Zea mays* L.) is the most important cereal crop in sub-Saharan Africa and is the world's most widely grown cereal crop as well as essential food source for millions of the world's poor (Abate et al. 2017). In sub-Saharan Africa, maize is a staple food for an estimated 50% of the population and an important source of carbohydrate, protein, iron, vitamins (A, B, E, and K), and minerals (magnesium, potassium, and phosphorus) and is grown on an estimated 100 million hectares throughout the developing world (Nsikak-Abasi and Okon 2013; Siyuan et al. 2018). In 2018, Zimbabwe got approximately 730,437 tonnes of maize, and the average yield was 613.1 Kg per hectare pointing to some technical inefficiencies. The average yield is lower as compared to the world average of 5923.7 Kg tonnes/ha and 2040.2 Kg/ha for Africa in the same year (FAOSTAT 2020). The smallholder farmers rely mainly on rain-fed production and in addition are often constrained by multiple constraints such as reduced soil fertility; limited income to access inputs such as fertilizers, improved seed, herbicides, and pesticides; unavailability of lucrative output markets; high cost of inputs; and reduced yield due to climate variability (Poole 2017; Rurinda et al. 2014). Researchers and development practitioners have reported reductions in agricultural yield due to extreme weather (UNCCS 2019). These unpredictable seasons have become a major constraint in smallholder crop and livestock production farming systems, and as such, the use of climate-smart agriculture (CSA) technologies becomes essential as a solution. Climate-smart agriculture technologies are innovations that sustainably increase agricultural productivity, help households to adapt and be resilient to climate change, and contribute to the reduction of greenhouse gas emissions (Steward et al. 2018).

Adaptation strategies for households can either be reactive (Shongwe et al. 2014), i.e., soil fertility maintenance through the use of animal manure and inorganic fertilizers, rotations, and intercropping in order to address problems linked to observed climate change impacts, or proactive CSA technologies such as use of new drought-tolerant varieties, use of early maturing varieties, and policy measures such as insurance policy. Zimbabwe has participated in interventions and alliances promoting CSA such as the DFID-funded Vuna (2015–2018) and the Africa Development Bank's Africa Climate-Smart Agriculture (ACSA) (2018–2025) (Thierfelder et al. 2017; Rosenstock et al. 2019). The Government of Zimbabwe (GoZ) has developed policies and interventions to lessen the impacts of climate change on agriculture. These policies include a child-friendly climate policy which targets education in schools on climate change issues, the climate-smart agriculture policy which promotes adoption of CSA by farmers, and the national climate policy which is targeting putting legal structures to guide businesses on becoming greener (GOZ 2018). Government and nongovernmental organizations have introduced a range of CSA in Zimbabwe which include conservation agriculture, drought-tolerant maize and legume varieties, cereal-legume intercropping and rotation systems, and improved fodder crops among others (Mujeyi 2018). Assuming economic rationality, smallholder farmers who rely on agriculture for livelihoods would adopt technologies that reduce costs of production while increasing benefits from greater incomes through improved yields. Smallholder farmers are heterogeneous, and as such, they adopt different combinations of CSA to address varying constraints that they face. These different technology bundles have different profitability levels because of the different input requirements associated with them as well as their potential impact on productivity.

The need to upscale CSA as adaptation mechanisms in order to improve or maintain high productivity levels in smallholder farming communities can effectively be achieved if profitability of these technologies and factors that enhance efficiency are properly understood. This study therefore aims to:

1. Estimate profitability and compare benefit-cost ratio (BCR) of maize production in smallholder farming communities across CSA technology bundles
2. Investigate the determinants of profit efficiency and identify the determinants thereof

The aim of this study is to contribute to the literature on CSA in Zimbabwe by analyzing profitability of current CSA technology bundles in maize production and technical inefficiency. Furthermore, using stochastic frontier model, the chapter aims to identify determinants of efficiency. The results will provide a better understanding of costs and benefits that would make it possible to design more economically efficient policies and programs to promote CSA technology adoption. Economic evaluations can provide critical information to those making decisions about the allocation of limited agriculture input resources across enterprises. The chapter provides empirical evidence from actual farmer behavior in uncontrolled environment, thus adding to studies from on-farm and on-station trials.

## CSA in Crop-Livestock Farming Systems

This study particularly chose to do analysis for maize (*Zea mays*) as it is the most important crop in smallholder farming systems in the four districts. Maize is the staple crop in Zimbabwe to 98% of the 12.7 million people in the country, and it provides 40–50% of the calories (Kassie et al. 2017). Average maize yield has dropped from a highest (after independence) of 2163.7 Kg/ha in 1985 to 667.8 Kg/ha in 2017 (FAOSTAT 2020). Maize productivity has been negatively affected by infertile soils, inadequate water due to drought, and erratic rainfall patterns caused by climate change as well as incidence of pests and diseases. Various CSA technologies have been used in maize production in an effort to boost yields. One such technology is conservation agriculture (CA) which consists of three key principles, namely, minimum tillage, permanent soil cover (mulching with crop residues or cover crop), and crop diversification (either temporal diversification, i. e., rotation, or spatial diversification, i. e., intercropping). CA offers benefits of increased yields when properly followed. Crop rotation and intercropping improve soil fertility through the nitrogen fixing characteristics of legumes. Large increases in maize yields in maize-groundnut rotations have been reported by CIMMYT researchers in Zimbabwe from long-term trials in smallholder farming systems (Waddington et al. 2007). Cereal-legume rotations also have benefits of reducing build-up of pests and diseases. Minimum soil disturbance reduces the rate and amount of soil erosion. Soil cover leads to reduced runoff, reduced soil erosion, increased water infiltration, and reduced evaporation of soil moisture (Michler et al. 2019; Steward et al. 2018; Thierfelder et al. 2017). Drought-tolerant maize (DTM) varieties have been promoted by organizations such as CIMMYT, and these are input-responsive, stress-tolerant, and high-yielding in comparison to traditionally grown commercial hybrids (Mujeyi and Mujeyi 2018).

---

## Methodology

### Study Area and Data Collection

This study uses data collected from a cross-sectional household survey using a structured interview in communities that were exposed to CSA technologies and data from key informant interviews with stakeholders who were involved in technology dissemination. Multistage sampling method was used to select the 386 respondents from maize-growing communities in 8 wards located in 4 districts, i. e., Goromonzi, Murehwa, Uzumba Maramba Pfungwe, and Mutoko. The economies of the four districts are integrated crop-livestock farming systems that rely on rain-fed production. Maize is the main cereal staple crop, while groundnut is the leading legume crop. The main livestock kept by the farmers are cattle and goats.

Livestock rely mainly on pastures for feed. Integration of the crop and livestock enterprises helps farmers to maximize resource uses. Stover from the field crops are used to feed livestock, while dung from the livestock is used to improve soil fertility through its use as manure.

Murehwa district falls under agro-ecological region IIB which is characterized by moderately high rainfall (700 mm annually) and moderate temperatures for crop production. This district has predominantly sandy loamy soils. The majority of Motoko's communal area is in natural region IV which is characterized by subtropical climate with cool dry winter and hot rainy summers (650 to 700 mm rainfall annually). The soils are shallow to moderately deep, yellowish red, coarse-grained loamy sands. Goromonzi is located in natural region II which also gets moderately high rainfall. Uzumba Maramba Pfungwe (UMP) has two natural regions (natural regions II to V), but wards were selected from natural region V.

Two wards that have been exposed to CSA technologies were chosen from each district. Households were randomly selected from one randomly selected village in each ward. Sample households were distributed within the wards according to the ward sizes (proportionate sampling). The farm households were interviewed by trained enumerators during the 2017/2018 crop season.

## Data Analysis

The study employed descriptive statistics and inferential statistics. It explored the economic assessment of CSA technologies through a cost-benefit analysis (CBA) and a stochastic profit frontier model. This study precisely probed farmers to state which CSA technologies they had used for various crops in one season and the inputs that were used and grain harvested after such an investment. Information from this economic analysis is important for price setting of commodities by government watchdogs, researchers working to improve the technologies, farmers using them, and donors and governments who fund research and development work.

## Economic Analysis of CSA

Farmers use different technologies as adaptation strategies, and their decisions on which technology to adopt under what area depend on the cost-effectiveness (Shongwe et al. 2014). Cost-benefit analysis thus plays an important role of farmers' decisions with regard to input costs, e.g., fertilizer, labor, seed, pesticide, etc., and was used in the economic analysis. Other researchers have used CBA in analyzing CSA technologies (Papendiek et al. 2016; Sain et al. 2017). Cost-benefit analysis (CBA) compares inputs and outputs for a technology in monetary terms (Shongwe et al. 2014). CBA for this study focuses on the quantitative evaluation of CSA technologies on the maize crop. All benefits and costs are estimated in monetary terms, and through calculating net benefits, the most economic efficient CSA are

identified. Benefits from maize include grain and stover used to feed livestock. The net benefits are calculated as follows:

$$NB = \Sigma (Bt - Ct) \quad (1)$$

$$NB = \Sigma Bt - \Sigma Ct \quad (2)$$

where:

NB represents the net benefits.

$\Sigma Bt$  = total benefits in year t.

$\Sigma Ct$  = total variable costs (TVC) in year t.

Bt is the combination of revenue from quantity of grain output and stover benefits.

$$\begin{aligned} \Sigma Bt &= \text{Total Revenue} \\ &= \Sigma (\text{Grain Output (Kg)} * \text{Unit grain prices (\$/Kg)} \\ &\quad + (\text{Stover Output (Kg)} * \text{Unit stover prices}) \end{aligned} \quad (3)$$

Average local market prices obtained by the farmers were used to compute returns. The farm gate price of the output is the value (price) farmers receive or can receive for their harvested crops. Total variable input costs refer to the sum of all variable input costs and vary from one CSA technology to another.

$$\begin{aligned} TVC &= \Sigma Ct \\ &= P_{\text{landprep}} Q_{\text{landprep}} + P_{\text{basalfertiliser}} Q_{\text{basalfertiliser}} \\ &\quad + P_{\text{topdressingfertiliser}} Q_{\text{topdressingfertiliser}} + P_{\text{seed}} Q_{\text{seed}} + P_{\text{labor}} Q_{\text{labor}} + \dots \\ &\quad + P_n Q_n \end{aligned} \quad (4)$$

The benefit-to-cost ratio (BCR) which is a financial ratio that is used to determine whether the amount of money made through a project will be greater than the costs incurred in executing was also computed as follows:

$$BCR = (\text{Benefit/Costs}) \quad (5)$$

For each CSA technology, the total costs incurred when using that strategy and benefits were used to compute the net benefit for that particular adaptation strategy.

### Return on Investment

Return on investment values help link the value of technologies to users. The return on investment (ROI) value is more powerful than the benefit-cost ratio because the ROI value shows the net return for a \$100 investment.

$$ROI = (\text{Net Benefit/TVC}) * 100 \quad (6)$$

### The Stochastic Profit Frontier Model

The stochastic frontier models have been used extensively even in agriculture, to model input-output relationships and to measure the technical efficiency (Greene 2010). These were first proposed in the context of production function estimation to account for the effect of technical inefficiency (Wang 2008; Dziwornu and Sarpong 2014). The analytical method has been used to compare the performance of farmers under different technological regimes. For example, the method has been used to examine the impact of technology adoption on output and technical efficiency of rice farmers or even beef farmers under various production systems (Omhile et al. 2016; Villano and Fleming 2006). In this study, the stochastic profit frontier model is used to compare inefficiency of farmers using CSA versus those who are not using any CSA technology. The model captures inefficiencies associated with different endowments as well as input and output prices. The model is specified as follows:

$$y = \beta'x + \varepsilon_i \quad (7)$$

where  $y$  is the observed outcome in this case maize profitability estimated by the gross margin (goal attainment),  $x$  is the logarithm of costs of that input, coefficient  $\beta$  are parameters estimated, and  $\varepsilon_i$  is the error term. The error structure is specified as follows:

$$\varepsilon_i = v_j - u_j \quad (8)$$

where  $v_j$  is the random error term and  $u_j$  is the inefficiency effects of farm  $j$ .

$U_j$  is independently distributed with mean  $\mu_1$  and variance  $\sigma_u^2$ .

Thus, the stochastic model is:

$$y = \beta'x + v_j - u_j, \quad (9)$$

$\beta'x + v$  is the optimal, frontier goal (e.g., maximal production output or minimum cost) pursued by the individual,  $\beta'x$  is the deterministic part of the frontier, and  $v \sim N[0, \sigma_v^2]$  is the stochastic part.  $v_j$  is the stochastic error term, and  $u_j$  is a one-sided error representing the technical inefficiency of firm  $j$ . Both  $v_j$  and  $u_j$  are assumed to be independently and identically distributed.

Inefficiency model is modelled using farm-specific, market-specific, and household characteristics and can therefore be estimated as follows:

$$U_j = \alpha + \alpha_1 Z_1 + \varepsilon_i \quad (10)$$

$$U_j = \alpha + \alpha_1 Z_1 + \alpha_2 Z_2 + \alpha_3 Z_3 + \dots + \alpha_n Z_n + \varepsilon_i \quad (11)$$

where  $U_j$  is technical inefficiency of the  $j$ th farm.

$Z_1$  to  $Z_n$  are the determinants and  $\varepsilon_i$  is the disturbance term and the coefficients  $\alpha$  are parameters estimated. Stochastic frontier models allow to analyze technical inefficiency in the framework of production functions. Production units such as

households are assumed to produce according to a common technology and reach the frontier when they produce the maximum possible output for a given set of inputs. Inefficiencies can be due to structural problems or market imperfections and other factors which cause countries to produce below their maximum attainable output. The stochastic frontier model decomposes growth of the output variable into changes in input use, changes in technology, and changes in efficiency. All parameters in the stochastic frontier and the technical inefficiency effects model are simultaneously calculated by a single-stage maximum likelihood estimation procedure using `sfcross` command in Stata (Karakaplan 2017). Table 1 gives a summary of all the variables thus used in the stochastic frontier model.

**Table 1** Stochastic frontier model variables

<b>Frontier regression model (efficiency factors)</b>			
$y_i$	$y_i$	Dependent variable – maize gross margin in US\$	Continuous variable
X1	SEEDcosts	Seed costs in US\$	Continuous variable
X2	DFERTcosts	Basal fertilizer costs in US\$	Continuous variable
X3	ANFERTcosts	Top dressing fertilizer costs in US\$	Continuous variable
X4	LANDPREcosts	Land preparation costs in US\$	Continuous variable
X5	MANUREcosts	Manure costs in US\$	Continuous variable
X6	HERBcosts	Herbicide costs in US\$	Continuous variable
X7	PESTcosts	Pesticide costs in US\$	Continuous variable
X8	LABOURcosts	Labor costs in US\$	Continuous variable
X9	PACKcosts	Packaging costs in US\$	Continuous variable
X10	OTHERcosts	Other costs in US\$	Continuous variable
<b>Inefficiency model</b>			
Z1	HHSEX	Gender of household head	Dummy, i.e., 1 = male 0 = female
Z2	HHEXPER	Experience household head (years)	Continuous variable
Z3	MEMBERSHIP	Membership to farmer groups	Dummy, i.e., 1 = yes 0 = no
Z4	CREDIT	Access to credit	Dummy, i.e., 1 = yes 0 = no
Z5	TRADERS	Number of traders locally	Continuous variable
Z6	TAR	Distance to tar (km)	Continuous variable
Z7	Kmextension	Distance to extension (Km)	Continuous variable
Z8	TLU	Total livestock units	Continuous variable
Z9	AGROREGION	Agro-ecological region	Dummy, i.e., 1 = wetter (II) 0 = otherwise (drier III and IV)
Z10	EXTNcontact	Frequency of extension contact	Continuous variable
Z11	CSAadoption	Use of CSA in maize production	Dummy, i.e., 1 = yes 0 = otherwise

**Table 2** Maize CSA technologies

Maize technology	Goromonzi	Murehwa	Mutoko	U.M.P	Whole sample	Chi square
Intercropping	24.0%	21.6%	2.0%	5.4%	16.1%	24.23***
Sole CN	5.5%	7.2%	0.0%	6.5%	5.4%	3.66
Rotation	39.0%	54.6%	66.0%	47.3%	48.4%	12.88**
Minimum tillage	39.0%	35.1%	48.0%	24.7%	35.8%	8.89**
DT maize	13.7%	11.3%	36.0%	12.9%	15.8%	17.85***
Manure use	13.7%	21.6%	14.0%	8.6%	14.5%	6.69*
Mulching	4.1%	5.2%	10.0%	0.0%	4.1%	8.59**

\*\*\*, \*\*, and \* indicates significance level at 1%, 5% and 10%

## Results and Discussion

Profitability across CSA technology bundles was estimated using cost-benefit analysis, and the stochastic profit frontier model was estimated to see if CSA adoption has a significant effect on technical inefficiency. Tables 2, 3, and 4 show the results of the analysis with subsequent discussions.

### CSA Adaptation Strategies Employed by Households in Maize Production

Maize production is negatively affected by climate change, and as such, adoption of CSA technologies is key to increasing yields. Table 2 shows the CSA technologies currently being used by the farmers.

The results show that farmers use various CSA technologies in maize production, with crop rotation being the highest in Mutoko followed by Murehwa (66% and 54.6%, respectively). Minimum tillage and DT maize are highest in Mutoko (48% and 36%, respectively). Few farmers (less than 10%) are not using any CSA technologies in maize production. This highlights the importance of CSA in the smallholder farming communities. Adoption of CSA such as intercropping, rotation, minimum tillage, DT maize, manure use, and mulching was significantly different across the study districts. Overall, CSA technology use is still low with less than 50% of households adopting CSA across all the districts except for rotation which is adopted by more than 50% of households in Murehwa and Mutoko districts. Farmers highlighted during FGDs that manure use had become low as there was an outbreak of theileriosis which led to most households being left with no cattle, which are the major source of manure. Manure from small ruminants and poultry is prioritized for use in horticulture gardens. Farmers also cited that technologies such as minimum tillage promoted by NGOs particularly basin making with hoes were strenuous in as much as they could be done bit by bit in the dry season for farmers with fencing. This was not so for the majority with unfenced fields who therefore needed to do it at the onset of the season. This has led to farmers shunning basins in favor of even hiring in



**Table 3** Results of cost-benefit analysis

Cost-benefit indicators	Maize technology cluster				
	Cluster 1 N = 178	Cluster 2 n = 163	Cluster 3 n = 24	Cluster 4 n = 21	ALL n = 386
Grain (Kg)	1646.41	1815.61	1833.51	1266.87	1711.02
Grain revenue (\$)	643.94	705.14	752.63	488.18	668.91
Stover (Kg)	823.21	907.80	916.75	633.43	855.51
Stover revenue (\$)	32.93	36.31	36.67	25.34	34.22
<b>Total revenue</b>	<b>676.87</b>	<b>741.45</b>	<b>789.30</b>	<b>513.52</b>	<b>703.13</b>
Land preparation costs	68.85	65.37	67.81	77.46	67.75
Seed (Kg)	25.72	25.20	26.60	29.76	25.78
Seed costs (\$)	67.60	71.71	69.56	68.73	69.59
Compound D fertilizer (Kg)	204.97	208.33	247.40	180.58	207.80
Compound D fertilizer costs	137.76	138.44	151.12	134.94	138.76
Ammonium nitrate fertilizer (Kg)	184.39	187.66	192.53	178.17	185.99
Ammonium nitrate fertilizer costs (\$)	137.43	137.46	137.08	141.96	137.68
Manure (carts)	0.00	0.02	0.00	0.00	0.01
Manure costs (\$)	30.39	33.22	47.60	30.16	32.72
Herbicide costs (\$)	1.55	2.01	0.29	0.48	1.61
Pesticide costs (\$)	0.38	0.23	2.08	0.00	0.40
Labor costs (\$)	66.36	72.74	47.67	119.05	70.91
Maize packaging costs (\$)	5.02	6.68	5.05	4.33	5.71
Other costs (\$)	0.21	0.88	2.03	0.00	0.61
<b>Total variable costs (TVC)</b>	<b>515.56</b>	<b>528.75</b>	<b>530.30</b>	<b>577.11</b>	<b>525.74</b>
<b>Gross margin</b>	<b>161.30</b>	<b>212.70</b>	<b>259.00</b>	<b>-63.59</b>	<b>177.39</b>
<b>BCR</b>	<b>1.42</b>	<b>1.50</b>	<b>1.69</b>	<b>0.90</b>	<b>1.44</b>
<b>ROI</b>	<b>42.17</b>	<b>50.06</b>	<b>68.82</b>	<b>-9.59</b>	<b>44.42</b>

\*\*\*, \*\*, and \* indicates significance level at 1%, 5% and 10%

animal-based tillage services. Minimum tillage could be achieved using animal-drawn rippers and direct seeders, but farmers highlighted that there has been an outbreak of January diseases which saw farmers losing cattle and draft power was the hardest hit. Mulching and intercropping under maize also recorded the least frequencies. Farmers highlighted that mulching was difficult to come by given that stover was used to feed livestock. The study further identified CSA technology combinations in maize production using principal component analysis-clustering. Four distinctive clusters were identified, i.e., Technology Cluster 1 (dominantly minimum tillage with lower use of rotation, DT maize, manure, and intercrop), Technology Cluster 2 (dominantly rotation use with lower use of intercrop and very low DT, manure, and minimum tillage), Technology Cluster 3 (higher use of mulch, manure, and DT maize, average use of minimum tillage and rotation, and less intercrop), and Technology Cluster 4 (conventional).

**Table 4** The stochastic frontier model results

Variables	Coef.	Std. Err	P value	
<b>Frontier regression model (efficiency factors)</b>				
X1	SEEDcosts	102.41	151.51	0.50
X2	DFERTcosts	-166.68**	67.53	0.01
X3	ANFERTcosts	-40.02	67.85	0.56
X4	LANDPREPcosts	106.57	105.16	0.31
X5	MANUREcosts	11.6	27.17	0.67
X6	HERBcosts	-93.47	74.80	0.21
X7	PESTcosts	15.98	121.90	0.90
X8	LABOURcosts	-28.28	24.82	0.25
X9	PACKcosts	1362.15***	79.66	0.00
X10	OTHERcosts	-208.07**	96.51	0.03
	_cons	-642.06	324.50	0.05
<b>Inefficiency model</b>				
Z1	HHSEX	-51.86	72.02	0.47
Z2	HHEXPER	152.62**	69.20	0.03
Z3	MEMBERSHIP	18.08	63.86	0.78
Z4	CREDIT	117.29	76.06	0.12
Z5	TRADERS	-145.16**	60.61	0.02
Z6	TAR	-74.88	85.25	0.38
Z7	Kmextension	100.71	64.87	0.12
Z8	TLU	181.94***	59.94	0.00
Z9	AGROREGION	-60.21	63.55	0.34
Z10	EXTNcontact	-167.5**	82.10	0.04
Z11	CSAadoption	-297.64**	125.80	0.02
	_cons	436.91**	201.05	0.03
Usigma				
	_cons	4.65	7.77	0.55
Vsigma				
	_cons	11.78***	0.09	0.00
	sigma_u	10.22	39.70	0.80
	sigma_v	361.46***	15.36	0.00
	Lambda	0.03	42.72	1.00

\*\*\*, \*\*, and \* indicate statistical significance at 1%, 5%, and 10%, respectively

## Economic Analysis of Maize

Economic analysis was performed to estimate the net return and benefit-cost ratio in various CSA technology bundles. A comparison of costs and returns from various CSA technology combinations in maize production is presented in Table 3.

The results show that the farmers who used CSA had higher gross margin ranging from \$259 (return on investment of 69%) with a BCR of 1.69 under higher CSA use

to \$161.30 (return on investment of 42%) and a BCR of 1.42 under low CSA use compared to a negative gross margin under sole conventional practices (−\$63.59) with a BCR of 0.9 but negative ROI of close to 10%. This indicates that farmers get at least more than \$40 for every \$1 spent in maize production using CSA technologies. The difference in profitability is mainly maybe a result of yield differences of conventional system versus CSA. These findings are consistent with the findings of Sain et al. (2017) who found that the incorporation of the CSA practices increased maize yields by 20% or more in comparison to existing farm management systems and Ali and Erenstein (2017) who found that yields differed according to production system and technology used.

### Estimated Stochastic Frontier Profit Function

The analysis was done using the `sfcross` Stata commands for the estimation of parametric stochastic frontier (SF) models using cross-sectional data (Bell and Bellotti 2014; Newton et al. 2014). Table 3 shows the maximum likelihood estimates for parameters of the stochastic frontier model. Almost all inputs have positive correlation with maize profitability except for fertilizer, herbicide, and labor costs that have negative effects on maize output variable.

Table 4 shows the determinants of technical inefficiency in maize production. Inefficiency is the dependent variable in the technical inefficiency model, and as such, variables with a negative (positive) coefficient sign will have a positive (negative) impact on technical efficiency. The analysis found that frequency of extension contact had a negative and significant effect on inefficiency. This implies that farmers with high frequency of extension contact are more technically efficient. Extension officers impart skills to farmers through one-on-one visits, training workshops, advisory services, and promotional events like exchange visits and field days. Farmers can thus learn about new technologies when they are in constant contact with extension, and thus they end up becoming more efficient farmers. This finding is in line with those of Dziwornu and Sarpong (2014), Welch et al. (2016), and Abdulai et al. (2018).

They are also in line with findings from Mango et al. (2015) who found a negative and statistically significant relationship between technical efficiency and extension contact in smallholder farming systems of Zimbabwe following the fast track land reform program. Another researcher, Konja et al. (2019), also found positive impact of extension contact on technical efficiency in certified groundnut seed production in Northern Ghana.

Correspondingly, the coefficient for number of locally available traders was negative and significant. This means that farmers who have access to farm gate traders are technically efficient. Maize farmers in most rural areas are constrained when it comes to capital and hence have difficulties to access distant markets. Therefore, if traders come to buy locally, this acts as an incentive for them to produce that crop knowing there is going to be a guaranteed market with potential to lower

transaction costs. Furthermore, the coefficient of CSA adoption was negative and significant. This means that farmers using CSA technologies are more efficient.

The stochastic frontier results showed that fertilizer and other costs have negative and significant effect on the inefficiency of maize profitability. The negative signs of the variables indicate that as these variables increase, the profit inefficiency of maize producers decreases. This means a unit increase in costs of the basal dressing fertilizer (DFERT) and top dressing (ANFERT) will lead to 166.68% and 40.02% increases in profitability, respectively. Basal and top dressing fertilizer applications are very critical for maize profitability, and the increase in use as proxied by costs will result in increased profitability. Total livestock units (TLU) and farming experience had significant positive coefficients implying that as the farmer's TLU/head size and farming experience increase, the profit inefficiency of the farmers also increases. This contradicts prior expectation and might be explained by the fact that experienced farmers are older and unwilling to invest in any new technologies that come around.

---

## Conclusions and Recommendations

The most economic adaptation strategy in the face of climate change would be adoption of CSA technologies as evidenced by positive gross margins and higher returns on investment when compared to the conventional way of farming. This is further supported by the positive effect of CSA adoption on technical efficiency. Farmers should however note that not all adaptation strategies are economical; thus, record-keeping of costs and income for regular computation of costs and benefits is crucial. Farmers can then choose technologies that give higher benefits or those that use less inputs given that most of the farmers are financially constrained. Based on variables that significantly influenced profit efficiency, the study makes three recommendations.

Government should continue putting resources towards supporting mobility of extension staff for continued extension to farmer contact and giving them adequate resource (information materials) so that they continue delivering key information on yield enhancing CSA technologies.

Policies to promote inorganic fertilizer use in order to boost soil fertility remain critical. Government should therefore strengthen the capacity of rural agro dealers to sell fertilizers locally at reasonable prices.

Policies to promote farm gate buying or market centers within wards should also be put in place as they have the potential to increase efficiency if farmers are aware of such a guaranteed market with very low transaction costs.

**Declaration** This research did not receive any specific grant from funding agencies in the public, commercial, or not-for-profit sectors.

**Data Availability** The household dataset can be obtained through permission from UKZN.

**Declaration of Competing Interest** The authors certify that they have no affiliations with or involvement in any organization or entity with any financial interest (such as honoraria; educational grants; participation in speakers' bureaus; membership, employment, consultancies, stock ownership, or other equity interest; and expert testimony or patent-licensing arrangements) or non-financial interest (such as personal or professional relationships, affiliations, knowledge, or beliefs) in the subject matter or materials discussed in this manuscript.

**Acknowledgment** The authors wish to appreciate the Ministry of Agriculture officials and Rural District Administrators for granting the permission to do data collection in the sampled districts.

---

## References

- Abate, Tsedeke, Monica F, Tahirou A, Girma TK, Rodney L (2017) Characteristics of Maize Cultivars in Africa : How Modern Are They and How Many Do Smallholder Farmers Grow? *Agriculture & Food Security* 6(30):1–17. <https://doi.org/10.1186/s40066-017-0108-6>
- Abdulai S, Nkegbe PK, Donkoh SA, Yildiz F (2018) Assessing the technical efficiency of maize production in northern Ghana: the data envelopment analysis approach. *Cogent Food Agric* 4 (1):1–14. <https://doi.org/10.1080/23311932.2018.1512390>
- Ali A, Erenstein O (2017) Climate risk management assessing farmer use of climate change adaptation practices and impacts on food security and poverty in Pakistan. *Clim Risk Manag* 16:183–194. <https://doi.org/10.1016/j.crm.2016.12.001>
- Bell LW, Bellotti B (2014) Whole-farm economic, risk and resource-use trade-offs associated with integrating forages into crop – livestock systems in . . . . *Agric Syst* 133:63–72. <https://doi.org/10.1016/j.agsy.2014.10.008>
- Dziwornu RK, Sarpong DB (2014) Application of the stochastic profit frontier model to estimate economic efficiency in small-scale broiler production in the Greater Accra region of Ghana. *Rev Agric Appl Econ* 17(02):10–16. <https://doi.org/10.15414/raae.2014.17.02.10-16>
- FAOSTAT (2020) Food and Agriculture Data. Food and Agriculture Organization of the United Nations. Statistics Division, Rome. <http://fenix.fao.org/faostat/internal/en/#data/QC>
- GOZ (2018) National Agriculture Policy Framework 2019–2030. Ministry of Lands, Agriculture, Water, Climate and Rural Resettlement, Harare
- Greene W (2010) A stochastic frontier model with correction for sample selection. *J Prod Anal* 34 (1):15–24. <https://doi.org/10.1007/s11123-009-0159-1>
- Kassie GT, Abdulai A, Greene WH, Shiferaw B, Abate T, Tarekegna A, Sutcliffe C (2017) Modeling preference and willingness to pay for drought tolerance (DT) in maize in rural Zimbabwe. *World Dev* 94:465–477. <https://doi.org/10.1016/j.worlddev.2017.02.008>
- Konja T, Dominic FNM, Oteng-Frimpong R (2019) Profitability and profit efficiency of certified groundnut seed and conventional groundnut production in northern Ghana: a comparative analysis. *Cogent Econ Financ* 7(1). <https://doi.org/10.1080/23322039.2019.1631525>
- Mango N, Makate C, Hanyani-Mlambo B, Siziba S, Lundy M (2015) A stochastic frontier analysis of technical efficiency in smallholder maize production in Zimbabwe: the post-fast-track land reform outlook. *Cogent Econ Financ* 3(1):1–14. <https://doi.org/10.1080/23322039.2015.1117189>
- Michler JD, Baylis K, Arends-Kuenning M, Mazvimavi K (2019) Conservation agriculture and climate resilience. *J Environ Econ Manag* 93:148–169. <https://doi.org/10.1016/j.jeem.2018.11.008>
- Mujeyi A (2018) Policy and institutional dimensions in climate-smart agriculture adoption: case of rural communities in Zimbabwe. In: Filho WL (ed) *Handbook of climate change resilience*. Springer Nature Switzerland AG. [https://doi.org/10.1007/978-3-319-71025-9\\_66-1](https://doi.org/10.1007/978-3-319-71025-9_66-1)

- Mujeyi K, Mujeyi A (2018) Fostering climate smartness in smallholder farming systems: business promotional approaches for improved maize varieties in eastern and southern Africa. In: Leal Filho W (ed) Handbook of climate change resilience. Springer International Publishing AG, part of Springer Nature. [https://doi.org/10.1007/978-3-319-71025-9\\_24-1](https://doi.org/10.1007/978-3-319-71025-9_24-1)
- Karakaplan MU (2017) The Stata Journal. In: The Stata, edited by Joseph H Newton and Nicholas J Cox. Vol. 17. College Station, Texas, USA: The Stata Press
- Newton HJ, Cox NJ, Nichols A, De W, Gilmore L (2014) The Stata Journal. *Stata J* 4:778–797
- Nsikak-Abasi AE, Okon S (2013) Sources of technical efficiency among smallholder maize farmers in Osun state of Nigeria. *Discourse J Agric Food Sci* 1(4):48–53. <http://docsdrive.com/pdfs/medwelljournals/rjasci/2010/115-122.pdf>
- Omhile T, Renato V, David H (2016) Evaluating the productivity gap between commercial and traditional beef production systems in Botswana. *AGSY* 149:30–39. <https://doi.org/10.1016/j.agsy.2016.07.014>
- Papendiek F, Tartiu VE, Morone P, Venus J (2016) Assessing the economic profitability of fodder legume production for green biorefineries – a cost-benefit analysis to evaluate farmers profitability 112:3643–3656. <https://doi.org/10.1016/j.jclepro.2015.07.108>
- Poole N (2017) Smallholder agriculture market participation. <https://doi.org/10.3362/9781780449401>
- Rosenstock TS, Rohrbach D, Nowak A, Girvetz E, Tracking Progress. (2019) The Climate-Smart Agriculture Papers. The Climate-Smart Agriculture Papers. <https://doi.org/10.1007/978-3-319-92798-5>
- Rurinda J, Mapfumo P, Van Wijk MT, Mtambanengwe F, Rufino MC (2014) Climate risk management sources of vulnerability to a variable and changing climate among smallholder households in Zimbabwe: a participatory analysis. *Clim Risk Manag* 3:65–78. <https://doi.org/10.1016/j.crm.2014.05.004>
- Sain G, María A, Corner-doloff C, Lizarazo M, Nowak A, Martínez-barón D, Andrieu N (2017) Costs and benefits of climate-smart agriculture: the case of the dry corridor in Guatemala. *Agric Syst* 151:163–173. <https://doi.org/10.1016/j.agsy.2016.05.004>
- Shongwe P, Masuku MB, Manyatsi AM (2014) Cost benefit analysis of climate change adaptation strategies on crop production systems: a case of Mpolonjeni Area Development Programme (ADP) in Swaziland 3(1):37–49. <https://doi.org/10.5539/sar.v3n1p37>
- Siyuan S, Tong L, Liu RH (2018) Corn phytochemicals and their health benefits. *Food Sci Human Wellness* 7(3):185–195. <https://doi.org/10.1016/j.fshw.2018.09.003>
- Steward PR, Dougill AJ, Thierfelder C, Pittelkow CM, Stringer LC, Kudzala M, Shackelford GE (2018) The adaptive capacity of maize-based conservation agriculture systems to climate stress in tropical and subtropical environments: a meta-regression of yields. *Agric Ecosyst Environ* 251(2017):194–202. <https://doi.org/10.1016/j.agee.2017.09.019>
- Thierfelder C, Chivenge P, Mupangwa W, Rosenstock TS, Lamanna C, Eyre JX (2017) How climate-smart is conservation agriculture (CA)? – its potential to deliver on adaptation, mitigation and productivity on smallholder farms in Southern Africa. <https://doi.org/10.1007/s12571-017-0665-3>
- UNCCS (2019) Climate action and support trends. United Nations Climate Change Secretariat, Bonn
- Villano R, Fleming E (2006) Technical inefficiency and production risk in Rice farming: evidence from Central Luzon Philippines. *Asian Econ J* 20(1):29–46. <https://doi.org/10.1111/j.1467-8381.2006.00223.x>
- Waddington SR, Karigwindi J, Chifamba J (2007) The sustainability of a groundnut plus maize rotation over 12 years on smallholder farms in the sub-humid zone of Zimbabwe. *African Journal of Agricultural Research*. 2(8):342–348
- Wang H-J (2008) Stochastic frontier models. In: The new Palgrave dictionary of economics, pp 925–928. <https://doi.org/10.1057/9780230226203.1623>
- Welch EW, Villanueva AB, Jha Y, Ogwal-omara R, Welch E, Wedajoo S, Halewood M (2016) Adoption of climate smart technologies in East Africa findings from two surveys and participatory exercises with farmers and local and experts. <https://doi.org/10.13140/RG.2.2.24562.09927>

**Open Access** This chapter is licensed under the terms of the Creative Commons Attribution 4.0 International License (<http://creativecommons.org/licenses/by/4.0/>), which permits use, sharing, adaptation, distribution and reproduction in any medium or format, as long as you give appropriate credit to the original author(s) and the source, provide a link to the Creative Commons license and indicate if changes were made.

The images or other third party material in this chapter are included in the chapter's Creative Commons license, unless indicated otherwise in a credit line to the material. If material is not included in the chapter's Creative Commons license and your intended use is not permitted by statutory regulation or exceeds the permitted use, you will need to obtain permission directly from the copyright holder.





# Role of Cassava and Sweetpotato in Mitigating Drought in Semi-Arid Makueni County in Kenya

# 14

C. M. Githunguri and E. N. Njiru

## Contents

Introduction .....	242
Farmer Interviews .....	245
Survey Observations and Synthesis in a Semi-Arid Area in Kenya .....	246
Cassava: Postanalysis .....	251
Sweetpotato: Postanalysis .....	253
Conclusions .....	255
References .....	255

## Abstract

Cassava and sweetpotato are major factors in food security across sub-Saharan Africa. Though cassava and sweetpotato varieties that are early maturing and resistant to diseases have been developed, many farmers still grow local varieties. Cassava and sweetpotato cultivars that mature between 6 and 12 and 3 and 4 months after planting, respectively, are available. The objective of the synthesis was to obtain a general overview of cassava and sweetpotato production in Matiliku subcounty of Makueni County in semi-arid eastern Kenya before the establishment of a seed system for them. Participatory rural appraisal and focused group discussions with key stakeholders in Makueni County on the current status

This chapter was previously published non-open access with exclusive rights reserved by the Publisher. It has been changed retrospectively to open access under a CC BY 4.0 license and the copyright holder is “The Author(s)”. For further details, please see the license information at the end of the chapter.

C. M. Githunguri (✉)

Kenya Agricultural and Livestock Research Organization (KALRO) Food Crops Research Centre  
Kabete, Nairobi, Kenya

E. N. Njiru

KALRO Katumani, Machakos, Kenya

e-mail: [elias.njiru@kalro.org](mailto:elias.njiru@kalro.org)

© The Author(s) 2021

W. Leal Filho et al. (eds.), *African Handbook of Climate Change Adaptation*,  
[https://doi.org/10.1007/978-3-030-45106-6\\_11](https://doi.org/10.1007/978-3-030-45106-6_11)

241



of these crops provided very useful information. It was observed that there are a few early cassava and sweetpotato adopters, meaning a lot of effort in communicating the need to commercialize them needs to be made. Even though the farmers had sufficient experience in growing them at subsistence level, they were searching for cultivars that combine both nutritional and food security. There is a need to engage more extension service providers in order to campaign on their adoption. There is a need to carryout training and awareness creation on their role in food security and wealth creation.

---

**Keywords**

Cassava · Food security · Kenya · Makueni · Sweetpotato

---

**Introduction**

Cassava and sweetpotato produce starchy tuberous roots. Cassava and sweetpotato may be sweet or bitter depending on the variety. The crops are resistant to drought and are mainly propagated through stem cuttings or vines. Cassava and sweetpotato can adapt to diverse climatic conditions, survive long dry spells, and can be harvested and stored on a flexible time schedule, all of which qualifies cassava and sweetpotato as food security crops and technologies that respond well to climate change. Cassava and sweetpotato tuberous roots are rich in carbohydrates and are a staple food for many Africans. They are also used to manufacture alcohol. The leaves are richer in protein and minerals than the tuberous roots both qualitatively and quantitatively and are used both as vegetable and fodder. Cassava and sweetpotato have high potential if people are sensitized to their usefulness and nutritive value. Currently, women and children usually grow cassava and sweetpotato as food security crops. However, the scenario changes when the two crops are grown for commercial purposes with men playing a prominent role (Nweke et al. 2002).

Thirty-centimeter (30) stem cassava cuttings are planted upright, slanting, or buried horizontally. Sweetpotato is propagated also from 30 cm vines, about 2/3 of which are inserted in the ground. Both crops have a great yield potential of 20–50 t/ha of root dry weight in the tropics. This yield potential has yet to be exploited as farmers are producing an average of less than 10 t/ha. Cassava and sweetpotato provide 8% or more of the minimum calories requirements of some 750 million people in the tropics, making it one of the most important energy sources in the human diet. Cassava and sweetpotato have great potential as industrial starch production crops and hence provide employment at the production, marketing, and sales levels. Given that the demand for food and feed remains unsatisfied and the time pressure to meet the challenge is increasing rapidly, cassava and sweetpotato can help alleviate this problem.

Cassava and sweetpotato produce about 10 times more carbohydrates than most cereals per unit area and are ideal for production in marginal and drought prone areas, which comprise about 75% of Kenya (Githunguri et al. 1998; Githunguri

2002; Nweke et al. 2002). Despite their great potential as a food security and income generation crops among rural poor in marginal lands, their utilization remain low. The potential to increase cassava and sweetpotato utilization is enormous with increased recipe range (Githunguri 1995). The International Institute of Tropical Agriculture (IITA) has officially recognized cassava as a new cash commodity and a vital food in Africa. The Common Fund for Commodities has recognized cassava as an internationally tradable commodity. The Intergovernmental Group on Grains has adopted cassava as a commodity. Cassava and sweetpotato can accelerate development and improve livelihoods of Kenyan rural communities as has been demonstrated in Vietnam and Thailand. Adoption of improved cassava production, processing, and marketing technologies earns these countries about one million US\$ per annum. This model is being pursued by initiatives in Africa such as the NEPAD Pan African Cassava Initiative, Sub-Saharan Africa Challenge Program, and the South African Root Crops Research Network and East African Root Crops Research Network.

Cassava and sweetpotato are major factors in food security across sub-Saharan Africa. In Kenya, cassava is grown in over 90,000 ha with an annual production of about 540,000 tons. Cassava (*Mahihot esculenta* Crantz.) is a relatively neglected tropical root crop in East and southern Africa (Githunguri 1995; Githunguri et al. 2017a, b, c). It is grown widely in East Africa in areas below 1500 m above sea level (Acland 1985). Cassava production in Kenya is concentrated in three main regions: Coastal, Central, and Western region. Western and Coastal regions are the main cassava producing areas, producing over 80% of the recorded cassava output in the country (Githunguri et al. 2017a). Though cassava is considered to be a food security crop in the sub-Saharan Africa, its production in Kenya is low compared to other crops like maize, beans, and sorghum. Its consumption is low especially in the central region of Kenya where it is considered a poor man's crop and is usually consumed during periods of food scarcity. Despite its high production in the coastal and western regions of Kenya, utilization is limited to human consumption. In order to promote production, which has been decreasing in recent years, there is a need to explore and identify other uses of cassava.

According to FAO (1990), Africa produces about 42% of the total tropical world production of cassava and contributes significantly to food security across sub-Saharan Africa. Githunguri et al. (1998) and Nweke et al. (2002) noted that cassava could grow well in marginal lands, requires low inputs, and is tolerant to pests and drought. Cassava is grown in over 90,000 ha with an annual production of about 540,000 t in Kenya and could remain in the ground for 7–24 months after planting and then harvested thereafter (Githunguri et al. 2017a). Utilization of cassava remains low in Kenya because the fresh root tubers are limited to roasting and boiling for consumption only despite its great potential as a food security and income generating crop (Githunguri 1995; Githunguri et al. 2017a). However, it should be noted that cassava is widely used in Kenya by almost all communities despite the fact that there is still a lot of room for expansion on its use especially by industrialists who have yet to fully utilize cassava in food and stock feed manufacture. The Home Economics Department of the Ministry of Agriculture and other organizations have a

wide range of options in developing cassava recipes acceptable to a larger community (Githunguri 1995; Githunguri et al. 2017a). In Kenya, cassava is the second most important food root crop after *Solanum* potato. However, due to its small production base, it is ranked 36th out of 50 in KALROs 1991 priority setting exercise (KALRO 1995; Githunguri 1995; Githunguri et al. 2017a). There is a slow but steady increase in cassava production because its consumption has a direct effect on demand.

Variability studies by Rai et al. (1986) on cassava showed that phenotypic variance was higher than genotypic variance for all characteristics, which included plant height, tuberous root girth, length, and weight. Later rain-fed trials involving several cassava cultivars showed significant genotype by environment ( $g \times e$ ) interaction for yield (Naskar et al. 1989). Selection for a slightly higher than optimal leaf area index, and hence greater biomass, can lead to stable cassava yields across both favorable and stress environments. Further, according to Nartey (1981) and Githunguri et al. (2014), the harvested cassava yields depend on the distribution of dry matter between the useful and other parts of the plant, which may be affected by the sink capacity of the useful parts to accept photosynthates, as well as the capacity of the leaves to supply it. In sub-Saharan Africa, most boil and eat fresh cassava consumers prefer roots with high dry matter contents, which are boiled and consumed as vegetable (Nartey 1981; Githunguri et al. 2014). It is important to note that Dixon et al. (1994) had reported negative correlation between root dry matter content and root cyanogenic potential which is important when selecting cassava varieties targeting fresh tuberous root consumers. According to IITA (1990b) and Githunguri et al. (2016), useful yields of the cassava crop depend on its total biomass and its distribution among useful parts. As such, since the total light intercepted strongly depends on leaf area, the best yielding cassava is one that establishes adequate and efficient photosynthetic surface sufficiently early in the cropping season, maintains it at least over the duration of the moisture cycle, and partitions dry matter into yield (Cock 1985; IITA 1990a). Other studies (IITA 1990b) have shown that best root yields are obtained at a leaf area index of 3.5, with general reduction in yield as the leaf area indices increase.

African farmers usually grow cassava under field conditions where one or more of the resources are limiting. However, it should be noted that most of the research works carried out are under optimum management conditions (Githunguri et al. 2006). Importance of cassava as an industrial crop is increasing rapidly in several countries within the tropics and especially sub-Saharan Africa (Ayinde et al. 2004; Azogu et al. 2004; EFDI-Technoserve 2005; Ezedinma et al. 2005; Githunguri 1995; Onyango et al. 2006). According to several studies (Githunguri 2002; Odongo 2008; Tivana and Bvochora 2005), safety of cassava products is important and could be affected by agro-ecological zones and genotypes. According to Ekanayake et al. (1997a) and Ekanayake et al. (1997b), a cassava plant possesses several physiological parameters and processes that confer to it the ability to produce modest yield under a range of both abiotic and biotic stresses. Some of these parameters include heliotropism, leaf drooping, long fibrous roots, loss of leaves, high water use efficiency, and large source potential, and sink capacity (Ekanayake 1998; Githunguri 2002). Other studies have shown that the cassava value chain has three

main components: field production, processing, and marketing (Githunguri et al. 2017a, b, c). Though cassava varieties that are early maturing and resistant to diseases have been developed, many farmers in the cassava growing regions (coastal, central, and western) still grow local varieties (Githunguri et al. 1998, 2006, 2007a; Githunguri 2002). In addition, early maturing, high yielding, disease, and pest tolerant cassava cultivars developed through participatory breeding by the Kenya Agricultural and Livestock Research Organization (KALRO) are available to farmers (Githunguri et al. 2006, 2007a).

Sweetpotato is an important staple food in the East African region after banana and maize. It has high potential for livestock feed and industrial use as well (Onwueme 1978). Generally, small-scale farmers using traditional farming systems on marginal soils produce most of the sweetpotatoes and cassava. According to Onwueme (1978), yields of sweetpotato and cassava vary with cultivar, disease resistance, and location and production practices. Constraints to sweetpotato production in Kenya include the sweetpotato weevil, lack of adequate disease and pest-free planting materials, poor cultural practices, lack of appropriate storage and processing technologies, and poor market infrastructure (Lusweti et al. 1997; Githunguri et al. 2003). Although some trade occurs, there is minimal official record of international trade in sweetpotato. Kenya mainly meets her consumption needs almost exclusively through internal production. Thus, sweetpotatoes like cassava are consumed locally and hence traded in a closed economy. This suggests that prices are mainly dependent on local forces of supply and demand. Due to lack of external market, the aggregate demand for sweetpotato within Kenya is assumed to equal supply (Odendo et al. 2001). One of the major constraints towards cassava and sweetpotato production and commercialization is their low and slow multiplication ratio due to their being vegetatively propagated. This constraint is further compounded when their production is carried out in the arid and semi-arid areas where their multiplication can only be effectively and commercially multiplied under irrigation and high inputs. Most local cassava and sweetpotato cultivars are low yielding and are late maturing. Though cassava and sweetpotato varieties that are early maturing and resistant to diseases have been developed, many farmers still grow local varieties. KALRO has sweetpotato cultivars that mature between 3 and 4 months and cassava cultivars that produce appreciable yields between 6 and 12 months after planting. As such, the specific objective of this synopsis was to obtain a general overview of cassava and sweetpotato production in Matiliku Division Makueni District in semi-arid eastern Kenya before the establishment of a seed system for the two crops.

---

## Farmer Interviews

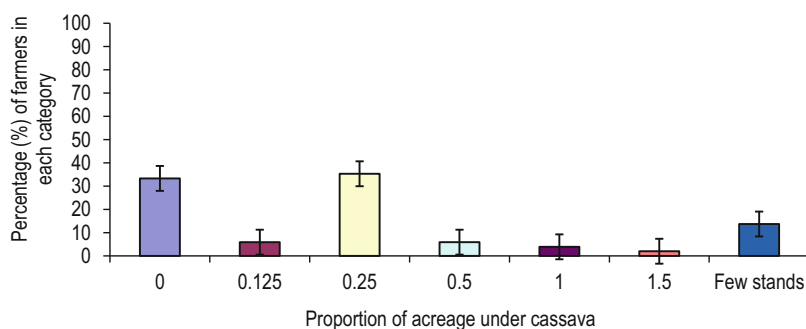
Participatory rural appraisal (PRA) and Focused Group Discussions with farmers, local leaders, extension staff, and other stakeholders were conducted at Matiliku Division in Makueni District. The PRA involving 51 farmers was conducted at a farm with an elevation of 1043 m above sea level located on Latitude S: 011.867812 and Longitude E: 042.78234. Using a semi-structured questionnaire, farmers were

interviewed individually whereby an overview on cassava and sweetpotato production in Matiliku was obtained. The data was subjected to descriptive analysis methods while charts were generated using Microsoft Excel application. The results were used to inform decisions on their training and cassava and sweetpotato production requirements.

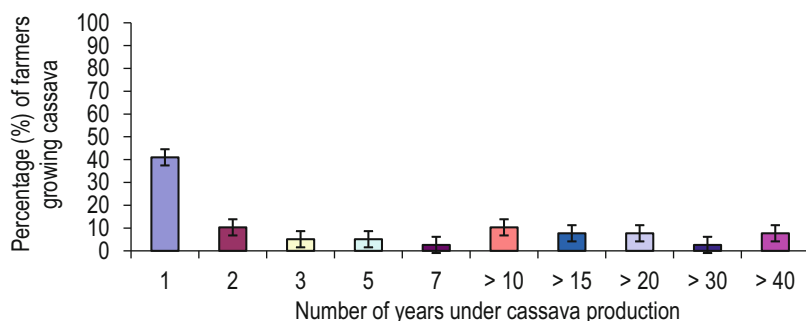
## Survey Observations and Synthesis in a Semi-Arid Area in Kenya

Figure 1 shows about 35.3% of the farmers put 0.25 acres under cassava cultivation while 13.7% have a few stands and 33.3% do not grow cassava at all. About 11.8% of the respondents put in cassava on land ranging from 0.5 to 1.5 acres and this category could be the early adopters.

The number of years under cassava production ranged between 1 and 40 years with only a few (7.7%) farmers indicating to have been growing cassava for a period above 40 years (Fig. 2). The majority of farmers, about 41.1%, have grown cassava



**Fig. 1** Proportion of acreage under cassava production in Matiliku Division, Nzaui District, Makueni County. Vertical bars represent the standard error between means ( $P = 0.05$ )



**Fig. 2** Number of years under cassava production and proportion of farmers growing cassava in Matiliku Division, Makueni (Nzaui) District. Vertical bars represent the standard error between means ( $P = 0.05$ )

for only 1 year while the rest had cassava-growing experience ranging between 2 and 30 years in proportions ranging between 5.1 and 10.3%. These results suggest that cassava is grown as a subsistence crop and a lot needs to be done if it is going to be commercialized in Matiliku.

According to Table 1 the majority of farmers, about 40.5%, were growing a local cassava cultivar whose name seemed to be unknown while 31.0% were growing a cultivar whose origin was uncertain. Among the known local cultivars, Kitwa was being grown by 7.1% of the respondents. A similar percentage (7.1%) of respondents were growing the improved “Mucericeri” cultivar obtained from KALRO and FIPS Africa. Other minor cultivars included 990,005, “Kiisungu,” and “Nyawo.” These results suggest that even though KALRO and some significant service providers have started distributing improved cultivars, a lot still needs to be done if cassava is going to play its rightful role in supplying the much needed calories.

Table 2 shows that the most significant methods of utilization include boiling and eating cassava for breakfast and chewing raw as a snack. About 10.1% of respondents mix cassava with maize and beans (“githeri”) while 17.7% grow cassava for

**Table 1** Types of cassava cultivars cited and proportion of farmers growing them in Matiliku Division, Makueni (Nzau) District

Types of cassava cultivars cited	Percentage (%) of farmers growing them
990,005 (improved)	2.4
FIPS Africa (improved)	2.4
(KALRO) improved	4.8
Kiisungu (local)	2.4
Kitwa (local)	7.1
Local (unknown)	40.5
Mucericeri (improved)	7.1
Nyawo (local)	2.4
Unknown (not certain improved or local)	31.0

**Table 2** Method of utilization of cassava and proportion of farmers involved in Matiliku Division, Makueni (Nzau) District

Method of utilization	Percentage (%) of farmers utilizing them
Boil and eat as a snack	2.5
Boil for breakfast	35.4
Chew raw	24.1
Give to friends	1.3
Have not utilized	5.1
Mix with “Githeri”	10.1
Mix with meat to make a stew	1.3
Peel, chip and mix with sorghum or maize	1.3
Process cakes	1.3
Sell in the market	17.7

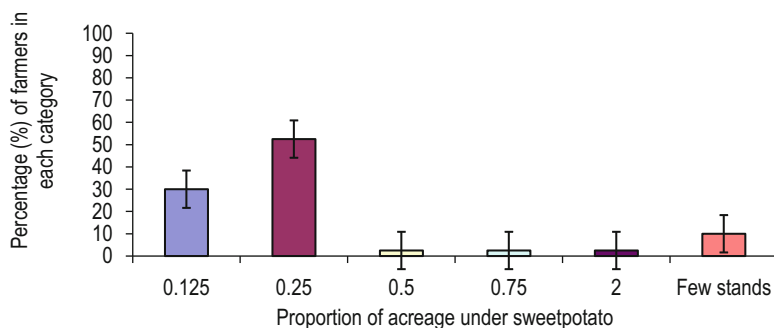
sale in the local market. Only 5.1% of the respondents indicated they have not utilized cassava in any way. The results indicate that there is very little processing of cassava taking place in Matiliku suggesting that there is need to carryout training and awareness creation on the role of cassava in food security and wealth creation.

Results in Table 3 show that KALRO (35.9%) has been largely responsible in the introduction of cassava as a viable technology in this area. 25.6% of the respondents were not certain about the origin of their cultivars, whereas 20.5% obtained them from the local market. It seems 20.5% of the respondents purchased cassava cuttings from the market, which is a positive sign on the viability of cassava being taken up as a commercial venture. There is need to increase the number of extension service providers in the area.

Figure 3 shows that the majority of respondents comprising 52.5%, 30%, and 10% grow sweetpotatoes on 0.25, 0.125 acres of land and only a few stands, respectively. The rest 7.5% grow sweetpotatoes on pieces of land ranging from 0.5 to 2 acres who seem to comprise the group of early adopters. These results suggest that sweetpotato is also grown as a subsistence crop. Serious efforts need to be put in place in order to move sweetpotato from subsistence level to commercialization in Matiliku.

**Table 3** Origin of cassava cultivars cited and proportion of farmers growing them in Matiliku Division, Makuani (Nzau) District

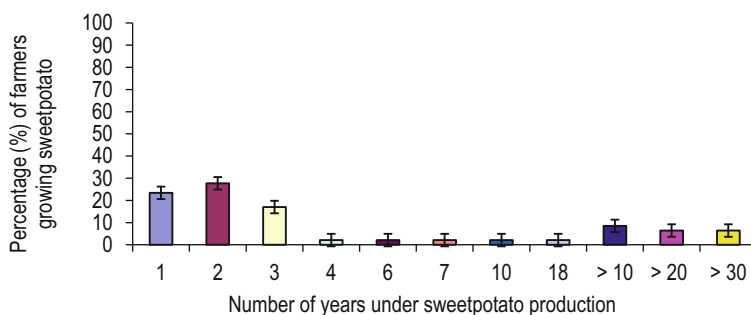
Origin of cassava cultivars cited	Percentage (%) of farmers growing them
Farmers	7.7
FIPs Africa	7.7
Inherited from parents	2.6
KALRO	35.9
Local market	20.5
Unknown	25.6



**Fig. 3** Proportion of acreage under sweetpotato production in Matiliku Division, Makuani (Nzau) District

Figure 4 shows that majority of the respondents, about 60%, have mainly grown sweetpotatoes for the last 3 years. The rest 40% have mainly grown sweetpotato for a period ranging from 4 to 30 years. This suggests that the concerted efforts that have been put in place by KALRO and its partners in extension service providers during the last 4 years have paid divided and all that is needed is to sustain the efforts.

The results in Table 4 show that 21.2% of the respondents were growing a local cultivar of an unknown origin while 16.7% of the farmers were growing an unknown improved cultivar presumably obtained from KALRO or other extension service providers. Sallyboro, an improved orange-fleshed sweetpotato cultivar, and “Mwezi moja,” a drought tolerant local cultivar, were the only cultivars being grown by an appreciable number of respondents, 15.2% and 10.6%, respectively. The rest of the



**Fig. 4** Number of years under sweetpotato production and proportion of farmers growing them in Matiliku Division, Makueni (Nzau) District

**Table 4** Types of sweetpotato cultivars cited and proportion of farmers growing them in Matiliku Division, Makueni (Nzau) District

Types of sweetpotato cultivars cited	Percentage (%) of farmers growing them
Kareti	4.5
KALRO	1.5
Kirinyaga	7.6
Kitharu	1.5
KSP20	3.0
Local	21.2
Mukanda	1.5
Mulala	1.5
Munyala	1.5
Mwezi moja	10.6
Nyawo	4.5
Sallyboro	15.2
SPK 013	1.5
SPK004	3.0
Unknown	4.5
Unknown improved	16.7



13 cultivars were thinly spread among the respondents with proportions ranging between 1.5% and 7.6%. The multiplicity of cultivars suggests that the farmers have accepted sweetpotato as an important part of their food security technologies and it seems they have been searching for a suitable cultivar. It seems a combination of Sallyboro and “Mwezi moja” have the qualities the farmers have been looking for: namely, food and nutrition security. There is a lot of potential to commercialize sweetpotato production in Matiliku if a sustainable seed system is established.

According to Table 5, the most popular method of utilization of sweetpotato is boiling and taken for breakfast. The sweetpotato is also a tradable commodity with 26.5% of respondents selling them in the local market. About 6% of the late adopters had not utilized sweetpotato at all. A few farmers were feeding sweetpotato vines to livestock while there was very little processing. In the area of utilization, there is a lot of room for training and improvement. However, farmers here like in the major sweetpotato producing areas in Western and Central Kenya could target the huge fresh market in Nairobi and other major urban centers.

Table 6 shows the origin of sweetpotatoes is mainly from KALRO (35.8%), neighboring farmers (34.0), and FIPs Africa (20.8). It seems KALRO and FIPs Africa have made major inroads in addition to the farmers being receptive and a willing congregation.

**Table 5** Method of utilization of sweetpotato and proportion of farmers involved in Matiliku Division, Makuani (Nzau) District

Method of utilization	Percentage (%) of farmers utilizing them
Boil for breakfast	42.2
Boil for lunch	1.2
Chew raw	8.4
Feed vines to livestock	3.6
Have not utilized	6.0
Process into cakes	3.6
Roast	7.2
Sell in the market	26.5
Sell vines	1.2

**Table 6** Origin of sweetpotato cultivars cited and proportion of farmers growing them in Matiliku Division, Makuani (Nzau) District

Origin of sweetpotato cultivars cited	Number of times cited by (respondents) farmers	Percentage (%) of farmers growing them
Farmers	18	34.0
FIPs Africa.	11	20.8
KALRO	19	35.8
Local market	1	1.9
Unknown	4	7.5

**Table 7** Education level, occupation, and main mode of communication by farmers involved in cassava and sweetpotato production in Matiliku Division, Makueni (Nzau) District

Education level	Occupation	Telephone	Percentage (%) of farmers within the main categories
Postsecondary	Farmer	Cellphone	8
Postsecondary	Farmer/service provider	Cellphone	2
Primary	Farmer	Cellphone	34
Primary	Farmer	Cellphone/ email	2
Primary	Farmer	None	6
Primary	Farmer/ shopkeeper	Cellphone	2
Secondary	Farmer	Cellphone	36
Secondary	Farmer	Cellphone/ email	2
Secondary	Farmer	None	2
Secondary	Farmer/ shopkeeper	Cellphone	6

Results in Table 7 show that the majority, over 70%, of cassava and sweetpotato farmers had attained at least the Primary Level of education with more than half of them having a secondary level of education. At least 2% of the farmers had an email address. The results suggest that the majority of the farmers were educated and had already started embracing modern technology meaning it will be easy to convince them to adopt the new cultivars.

## Cassava: Postanalysis

Cassava production and its optimized food, nutritional, and industrial positioning as a climate smart crop faces challenges including diseases, late maturing varieties, pests and lack of climate smart adaptable varieties, low yields, weak seed systems, insufficient value addition, limited market linkages, and insufficient mapping of gendered roles in production and marketing. Limited availability of clean planting materials has resulted in few agro producers growing improved varieties, hence reduced root yield and quality. The majority of cassava farmers (93%) in Kenya use planting materials from their own or neighbor's fields (Githunguri et al. 2014), hence a continued build-up of diseases and pests (Githunguri and Njaimwe 2013a, b, c, d; Githunguri 1983a, b). Unfortunately, the perception of cassava as a poor peoples' food has impacted negatively on national efforts to promote cassava as a viable, commercially marketable product which has confined it to subsistence production, rudimentary processing, and limited consumption (Githunguri et al. 2017a). There is need to address and change this negative attitude towards cassava through advocacy and change in policy. The minimal processing techniques are usually tedious, time-

consuming, low yielding resulting in products with unpredictable qualities and hence rarely stocked in markets. We believe that adjustments of locally available processing technologies accompanied by an aggressive vigorous promotion and marketing campaign will significantly raise the profile of climate smart crops like cassava and thus contribute to the improvement of food security, incomes, and community resilience.

Cassava (*Manihot esculenta* Crantz) is the fifth most important food crop in the world (Githunguri 2002). It produces more energy per unit area compared to most cereals (Githunguri et al. 2015; Githunguri and Amata 2015). The crop is drought tolerant and produces under marginally fertile soils where other crops fail (Githunguri et al. 2014); hence, it is the most resilient to climate change among all major African crops (Jarvis et al. 2012). Cassava is grown by smallholder agro producers in western, coastal, and eastern Kenya. Considering that about 75% of Kenya is arid or semi-arid and the majority of small-scale farmers in cassava growing areas are women, increased cassava production and consumption will contribute greatly towards poverty alleviation, food security, women empowerment, and wealth creation of the nation (Githunguri et al. 2007). In 2017 the country produced 1,112,000 tonnes from 90,394 ha, translating to 12 t/ha which is lower compared to 16 to 24 t/ha in China, Indonesia, and Thailand (FAO, IFAD, UNICEF, WFP and WHO 2017) and the crop potential of 90 t/ha (Cock et al. 1979). Lamu and Kisumu are among the major cassava producing counties in Kenya and the crop contributes 6% of the total household incomes (MOALF 2018). Production is dominated by low-yielding varieties that are susceptible to pests and diseases under poor crop and pest management practices. Major diseases are cassava mosaic (CMD) and cassava brown streak (CBSD) disease which cause yield losses of up to 100% with CBSD causing necrosis which renders roots unfit for food, feed, and industrial purposes (Monger et al. 2010). Pests such as cassava mealybugs (CMB) and cassava green mites (CGM) affect production particularly during the dry periods. Kenya Agricultural and Livestock Research Organization (KALRO) has identified improved varieties such as MM95/0183, Midgyera, and Katune (990005) and that are high yielding, early maturing, and tolerant to pests and diseases. Therefore, validating and upscaling improved varieties and good agronomic, pest and disease management technologies will contribute to increased productivity. Wide adoption of improved varieties will be enhanced if planting materials are bulked in close proximity to production areas to reduce transportation costs. Lack of an efficient seed delivery system has resulted in limited availability and accessibility of clean planting materials, resulting in 93% of the agro producers in Kenya using infected planting materials (Amata et al. 2012; Ekanayake and Githunguri 2000). This causes a buildup of pests and diseases further contributing to low productivity of clonally propagated crops (Githunguri et al. 1992). There is a need to have a system compliant with national regulations to avail high quality planting materials to agro producers, to address losses attributed to these pests and diseases. Use of tissue culture and three node technology to mass propagate disease free planting materials and bulk at three levels – primary (NARS, breeders' seed), secondary (Government, NGOs and other private Institutions), and tertiary (village

seed entrepreneurs) – could be beneficial in availing clean materials to agro producers. Cassava utilization in the target counties is limited to boiling, deep frying, roasting, and blending cassava with maize, millet, or sorghum flour to make porridge or “ugali” (Githunguri 1995). In Nigeria, the crop is processed into feeds and food products like garri. Cassava can replace 10–30% of maize in food and feeds, 60–70% in confectionery products, and up to 60% of barley in beer making, hence can relieve the demand for and importation of wheat and save on foreign exchange. This potential has been recognized and the Ministry of Agriculture in Kenya is enacting a law to enforce blending of maize and wheat with cassava flour. Production of high quality flour is a requirement for blending and hence improved processing technologies that will ensure safety of products will be validated and up-scaled. In addition, new products will be introduced to entrepreneurs who will be linked to markets to create employment and increase income generation.

---

### **Sweetpotato: Postanalysis**

Sweetpotatoes are important in the economy of poor households and are a major source of subsistence and cash income to farmers in agroclimatically disadvantaged regions and even in high potential areas of Kenya. Constraints to sweetpotato production in Kenya include the sweetpotato weevil, sweetpotato virus complex, lack of adequate disease and pest free planting materials, poor cultural practices, lack of appropriate storage and processing technologies, and poor market infrastructure. Effective control of major biotic and abiotic stresses on sweetpotatoes through selection and breeding of clones’ resistance and/or tolerant to them plus the availability of clean planting material will boost food availability significantly in arid and semi-arid lands through the establishment of sweetpotato based industries in sweetpotato growing areas. The objectives of the Root and Tuber Crops Programme in the Kenya Agricultural and Livestock Research Organization (KALRO) are to develop sweetpotato varieties that are widely adapted to diverse agro-ecological zones. The varieties should also be high yielding, early bulking, and drought resistant/tolerant, resistant to major biotic and abiotic stresses and have good root quality and especially high in  $\beta$ -carotene content (orange fleshed sweetpotatoes). The Kenya Agricultural and Livestock Research Organization has recognized the importance of involving farmers in their selection and breeding research programs.

Sweetpotato produces starchy tuberous roots. The crop is resistant to drought and is mainly propagated through vines. Sweetpotato can adapt to diverse climatic conditions, survive long dry spells and can be harvested and stored on a flexible time schedule, all of which qualifies it as a food security crop. Sweetpotato tuberous roots are rich in carbohydrates and are a staple food for many Africans. They are also used to manufacture alcohol. The leaves are richer in protein and minerals than the tuberous roots both qualitatively and quantitatively and are used both as vegetable and fodder. Sweetpotato has high potential if people are sensitized to their usefulness and nutritive value.

Sweetpotato is propagated also from 30 cm vines about 2/3 s of which are inserted in the ground. Both crops have a great yield potential of 20–50 t/ha of root dry

weight in the tropics. This yield potential has yet to be exploited as farmers are producing an average of less than 10 t/ha (Nweke et al. 1994). Sweetpotato provides 8% or more of the minimum calories requirements of some 750 million people in the tropics, making it one of the most important energy sources in the human diet. Sweetpotato has great potential as an industrial starch production crop and hence provide employment at the production, marketing, and sales levels. Given that the demand for food and feed remains unsatisfied and the time pressure to meet the challenge is increasing rapidly, sweetpotato can help alleviate this problem.

Sweetpotatoes have the potential to contribute towards increased and sustainable food security, poverty alleviation, and wealth and employment creation. As such, the Kenyan government needs to have challenges and opportunities addressed along the sweetpotato value chain. Kenya's Economic Recovery Strategy of 2003 focuses on creating employment and wealth in the various subsectors including agriculture which contributes about 30% to the gross domestic product and provides about 70% of employment opportunities annually (MoA 2005). The vision of the government Strategy for Revitalizing Agriculture and Kenya Vision 2030 (National Economic and Social Council of Kenya (NESC) 2007) is to make the sector profitable, commercially oriented, and competitive (MoA 2005). Value addition and efficiency in production, processing, and marketing of high quality competitive sweetpotato products in Kenya and beyond will be used to enhance household incomes, employment, and food and nutrition security.

Despite its great potential as a food security and income generation crop among rural poor in marginal lands, its utilization remains low. However, its utilization can be increased with an enhanced number of recipes. Sweetpotato can accelerate development and improve livelihoods of Kenyan rural communities as has been demonstrated in China. Studies indicate sweetpotato seed, flour, crisps, starch, livestock feeds, and ethanol as the six best bet sweetpotato technologies. However, there is need to focus on sweetpotato seed. Several small-scale sweetpotato-based technologies have been initiated in a number of countries and similar models can work for Kenya (Onyango et al. 2006). What is lacking is an effective technology transfer mechanism that makes it possible for sweetpotato farmers and processors in Kenya to test, select, and adopt or adapt the best options. There is need to train farmers and processors on good sweetpotato field production and manufacturing practices and facilitate their access to microcredit and market avenues to catalyze sufficient investment in the sweetpotato industry.

A successful commercial sweetpotato seed industry could lead to increased sweetpotato field production which could in turn lead to processing of products and better markets for sweetpotato products leading to increased incomes to the rural community thus leading to a reduction in poverty levels among them. This could also lead to increased utilization of quality sweetpotato products and enhanced food security as proposed by the ERS and the SRA. Quality sweetpotato products have the potential of greatly contributing to improved health of the rural populations and enhance nutritional security among small scale farmers.

With successful interventions, there will be need for policy makers to create policy instruments to absorb surplus sweetpotato, which will create incentives for local producers. Making it mandatory for processors to use a certain percentage of

sweetpotato, flour in making livestock feeds could achieve this. This would promote use of sweetpotato in addressing rural food security, industrialization, employment creation, rural urban migration, and rural youth occupation.

The sweetpotato value chain has three main components: field production, processing, and marketing. We will build strong ties with both public and private institutions engaged in research, extension, and social development in order to accomplish this linkage by the end of project. Though sweetpotato varieties that are early maturing and resistant to diseases have been developed, many farmers in the sweetpotato growing regions still grow local varieties. Many local sweetpotato cultivars take more than 6 months to mature, whereas the Kenya Agricultural and Livestock Research Organization has sweetpotato cultivars that mature between 3 and 4 months. Intensive multiplication and dissemination of the newly bred early maturing high yielding disease and pest tolerant cultivars will result in increased sweetpotato production and ensure a source of food and income for the rural households. Early maturing, high yielding disease, and pest tolerant sweetpotato cultivars developed through participatory breeding at various Kenya Agricultural and Livestock Research Organization Centres are available.

---

## Conclusions

There are a few early cassava and sweetpotato adopters, meaning cassava and sweetpotato are still being grown as a subsistence crop and a lot needs to be done if they are going to be commercialized in Matiliku. The farmers had sufficient experience in growing the two crops albeit at subsistence level. The farmers seemed to be searching for cultivars that combined both nutritional and food security. There is need to engage more extension service providers than there are currently in order to hasten the adoption of new cultivars. There is very little processing of these crops taking place in Matiliku suggesting that there is need to carryout training and awareness creation on their role in food security and wealth creation. Sallyboro, an improved orange-fleshed sweetpotato cultivar, and “Mwezi moja,” a drought tolerant local cultivar have been accepted by the farmers. There is a lot of potential to commercialize cassava and sweetpotato production in Matiliku if a sustainable seed system is established. Cassava and sweetpotato are tradable commodities in Matiliku. Farmers could target the huge fresh market in Nairobi and other major urban centers. Majority of the farmers are educated and could easily adopt new technologies.

---

## References

- Acland JD (1985) East African crops: an introduction to the production of field and plantation crops in Kenya, Tanzania and Uganda [by] J. D. Acland. Longman [for the] Food and Agriculture Organization, London, 1971. ISBN: 0582603013. 252 p
- Amata R, Ateka E, Kasina M, Githunguri C, Wangai A, Miano D, Mamati E, Githiri M, Kamau J, Ndolo P, Obiero H, Muli B, Mwaniki S, Kwach J, Lelegut D, Gichangi A, Macharia I, Kagondou A, Kuyia J, Sila M, Gathara V, Kihurani A, Agili S, Momanyi V, Mbugua B, Odero B, Wekesa

- N, Ochieng V, Omari J, Mbugua F, Kitisya A (2012) Constraints and opportunities of a clean seed delivery system for cassava and sweetpotato in Kenya. "Agricultural innovation system for improved productivity and competitiveness in pursuit of vision 2030". In the Proceedings of the 13th KARI Biennial Scientific Conference held in Nairobi at Kenya Agricultural Research Institute Headquarters from 22nd to 26th October 2012. pp 612–622
- Ayinde A, Dipeolu O, Adebayo K, Oyewole OB, Sanni LO, Adusei J, Westby A (2004) A cost-benefit analysis of the processing of a shelf stable cassava fufu in Nigeria. In: Book of abstracts of the sixth international scientific meeting of the cassava biotechnology network. CIAT, Cali
- Azogu I, Tewe O, Ezedinma C, Olomo V (2004) Cassava utilisation in domestic feed market. Root and Tuber Expansion Programme, Nigeria, 148 pp
- Cock JH (1985) Cassava. New potential for a neglected crop. Westview Press, Boulder and London, 191pp
- Cock JH, Franklin D, Sandoval G, Juri P (1979) The ideal cassava plant for maximum yield. *Crop Sci* 19:271–279
- Dixon AGO, Asiedu R, Bokanga M (1994) Breeding of cassava for low cyanogenic potential problems, progress and prospects. *ActaHorticulturae* 375:153–161
- EFDI-Technoserve (2005) Assessment of different models of cassava processing enterprises for the south and South-East of Nigeria, including the Niger Delta. Draft Final Report submitted to IITA-CEDP, March 2005
- Ekanayake IJ (1998) Screening for abiotic stress resistance in root and tuber crops. IITA Res Guide 68:46
- Ekanayake IJ, Githunguri CM (2000) Implications of biophysical site characteristics on growth and sustainable cassava production in the savannas of Nigeria. *Niger Meteorol Soc J* 2(2):33–45
- Ekanayake IJ, Osiru DSO, Porto MCM (1997a) Morphology of cassava. IITA Res Guide 61:1–30
- Ekanayake IJ, Osiru DSO, Porto MCM (1997b) Agronomy of cassava. IITA Res Guide 60:1–20
- Ezedinma C, Patino M, Sanni L, Okechukwu R, Ilona P, Akoroda M, Dixon A (2005) Investment options in the High Quality Cassava Flour (HQCF) enterprise. Presented at the Stakeholders meeting on Strategies on sourcing high quality cassava flour. IITA, Ibadan
- FAO (1990) Roots, tubers, plantains and bananas in human nutrition. FAO, Rome
- FAO, IFAD, UNICEF, WFP, WHO (2017) The state of food security and nutrition in the world 2017. Building resilience for peace and food security. FAO, Rome. 232pp. ISBN 978-92-5-109888-2
- Githunguri CM (1983a) Pests of cassava. In: Proceedings: Cassava production workshop, 7th–8th February 1983, Malindi, Kenya. 6p
- Githunguri CM (1983b) The place of cassava in coast agriculture and relevance to the research programme. In: Proceedings: Cassava production workshop, 7th–8th February 1983, Malindi, Kenya. 24p
- Githunguri CM (1995) Cassava food processing and utilization in Kenya. In: Egbe TA, Brauman A, Griffon D, Treche S (eds) Cassava food processing. CTA, ORSTOM, Wageningen, pp 119–132
- Githunguri CM (2002) The influence of agro-ecological zones on growth, yield and accumulation of cyanogenic compounds in cassava. A thesis submitted in full fulfilment for the requirements for the degree of Doctor of Philosophy in Crop Physiology, Faculty of Agriculture, University of Nairobi, 195pp
- Githunguri CM, Amata R (2015) Drought mitigating technologies: an overview of Cassava and Sweetpotato Production in Mukuyuni Division Makuani District in Semi-Arid Eastern Kenya. In the book "Adapting African Agriculture to Climate Change. Transforming Rural Livelihoods. The contribution of land and water management to enhanced food security and climate change adaptation and mitigation in the African continent" Edited by Walter Leal Filho, Anthony O. Esilaba, K. P. C. Rao and G. Sridhar" ISSN 1610–2010 ISSN 1610–2002 (electronic) Climate Change Management. ISBN 978–3–319-12999-0 ISBN 978–3–319-13000-2 (eBook). DOI <https://doi.org/10.1007/978-3-319-13000-2>. Library of Congress Control Number: 2014955614. Springer Cham Heidelberg New York Dordrecht London. © Springer International Publishing Switzerland 2015. pp 225–235

- Githunguri CM, Njaimwe AN (2013a) Cassava brown streak disease (CBSD) identification and management. KARI Information brochure series 2013/86. Kenya Agricultural and Livestock Research Organization (KALRO)
- Githunguri CM, Njaimwe AN (2013b) Cassava leaf spots disease identification and management. KARI Information brochure series 2013/88. Kenya Agricultural and Livestock Research Organization (KALRO)
- Githunguri CM, Njaimwe AN (2013c) Cassava anthracnose disease identification and management. KARI Information brochure series 2013/93. Kenya Agricultural and Livestock Research Organization (KALRO)
- Githunguri CM, Njaimwe AN (2013d) Cassava mosaic disease identification and management. KARI Information brochure series 2013/94. Kenya Agricultural and Livestock Research Organization (KALRO)
- Githunguri CM, Mailu AM, Kariuki CW, Gatumbi RW (1992) An overview of cassava diseases and pests in Kenya. In: Root and tuber pest management in Kenya. Proceedings of a national workshop, 3rd–7th August 1992 Mombasa, Kenya, pp 42–48
- Githunguri CM, Ekanayake IJ, Chweya JA, Dixon AGO, Imungi J (1998) The effect of different agro-ecological zones on the cyanogenic potential of six selected cassava clones. Post-harvest technology and commodity marketing. IITA, Ibadan, pp 71–76
- Githunguri CM, Migwa YN, Ragwa SM, Karoki MM (2003) Cassava and sweetpotato agronomy, physiology, breeding, plant protection and product development. Root and Tuber Crops Programme in KALRO-Katamani. Paper presented at the Joint Planning meeting organized under the Eastern Province Horticulture and Traditional Food Crops Project, held at Machakos, Kenya on 5<sup>th</sup>- 7<sup>th</sup> March 2003, 5p
- Githunguri CM, Karuri EG, Kinama JM, Omolo OS, Mburu JN, Ngunjiri PW, Ragwa SM, Kimani SK, Mkabili DM (2006) Sustainable productivity of the Cassava value chain: an emphasis on challenges and opportunities in processing and marketing Cassava in Kenya and beyond. A project proposal present to the Kenya Agricultural Productivity Project (KAPP) Competitive Agricultural Research Grant Fund, Research Call Ref No.KAPP05/PRC- CLFFPS –03. KAPP Secretariat 106p
- Githunguri CM, Mwiti S, Migwa Y (2007a) Cyanogenic potentials of early bulking cassava planted at Katumani, a semi-arid area of Eastern Kenya. Part 2 of 4 ISSN 1023-070/2007 African Crop Science Society, Uganda, Vol. 8, pp 925 – 927
- Githunguri CM, Karuri EG, Kinama JM, Omolo OS, Mburu JN, Ngunjiri PW, Ragwa SM, Mkabili DM (2007b) Sustainable productivity of the Cassava value chain: an emphasis on challenges and opportunities in processing and marketing Cassava in Kenya and beyond. In: Githunguri CM, Kwena K, Mungube E, Gatheru M (eds). KARI Katumani research centre annual report 2006. Kenya Agricultural and Livestock Research Organization (KALRO). pp. 149
- Githunguri CM, Amata R, Lung'ahi EG, Musili R (2014) Cassava: a promising food security crop in Mutomo, a semi-arid food deficit district in Kitui County of Kenya. *Int J Agric Resour Gov Ecol* 10(3):311–323
- Githunguri CM, Lung'ahi EG, Kabugu J, Musili R (2015) Cassava farming transforming livelihoods among smallholder farmers in Mutomo a Semi-Arid District in Kenya. In the book “Adapting African Agriculture to Climate Change. Transforming Rural Livelihoods. The contribution of land and water management to enhanced food security and climate change adaptation and mitigation in the African continent” Edited by Walter Leal Filho, Anthony O. Esilaba, K. P. C. Rao and G. Sridhar” ISSN 1610–2010 ISSN 1610–2002 (electronic) Climate Change Management. ISBN 978–3–319-12999-0 ISBN 978–3–319-13000-2 (eBook). DOI <https://doi.org/10.1007/978-3-319-13000-2>. Library of Congress Control Number: 2014955614. Springer Cham Heidelberg New York Dordrecht London. © Springer International Publishing Switzerland 2015. pp 215–224
- Githunguri CM, Lung'ahi EG, Amata R, Gatheru M, Musili R, Njiru E (2016) The effect of a dry agroecological zone on selected growth and yield parameters of three elite cassava genotypes grown in Mutomo Sub-County of Kitui County in Kenya. In: Esilaba A, Githunguri C, Kimani



- S, Njeru P, Lekasi J, Maina F, Muniafu M, Miriti J, Gachene C, Baaru M, Muriuki A, Nyamwaro S, Kibunja C, Mangale N (eds) Proceedings of the 27th soil science society of East Africa and the 6th African soil science society conference, held 20–25 October 2013. Soil Science Society of East Africa (SSSEA), Nakuru, pp 1100–1104
- Githunguri CM, Gatheru M, Ragwa SM (2017a) Cassava production and utilization in the coastal, eastern and western regions of Kenya. In: Klein C (ed) Chapter 3 handbook on cassava: production, potential uses and recent advances. Series: plant science research and practices. Nova Science Publishers, Inc., Hauppauge. ISBN: 978-1-53610-291-8
- Githunguri CM, Gatheru M, Ragwa SM (2017b) Status of cassava processing and challenges in the coastal, eastern and western regions of Kenya. In: Klein C (ed) Chapter 11 handbook on cassava: production, potential uses and recent advances. Series: plant science research and practices. Nova Science Publishers, Inc., Hauppauge. ISBN: 978-1-53610-291-8
- Githunguri CM, Gatheru M, Ragwa SM (2017c) Trend in the trade of cassava products in the coastal, eastern and western regions of Kenya. In: Klein C (ed) Chapter 19 handbook on cassava: production, potential uses and recent advances. Series: plant science research and practices. Nova Science Publishers, Inc., Hauppauge. ISBN: 978-1-53610-291-8
- IITA (1990a) Cassava in tropical Africa. Reference Manual IITA, Ibadan, Nigeria, 176pp
- IITA (1990b) Targeting cassava breeding and selection. In: Proceedings of the 4th West and Central Africa Root Crops workshop. Lome, Togo. 12–16 December 1988. IITA Meeting Reports Series 1988/6, pp 27–30
- Jarvis A, Ramirez-Villegas J, Vanessa B, Campo H, Navarro-Racines C (2012) Is cassava the answer to African climate change adaptation? *Trop Plant Biol* 5(1):9–29. <https://doi.org/10.1007/s12042-012-9096-7>
- KALRO (1995) Cassava research priorities at the Kenya Agricultural Research Institute, Cassava Priority Setting Working Group. Kenya Agricultural and Livestock Research Organization (KALRO).
- Lusweti CM, Kiiya W, Kute C, Laboso A, Nkonge C, Wanjekeche E, Lobeta T, Layat S, Kakuko A, Chelang E (1997) The farming systems of Sebit: In: Summary from PRA activities. Kenya Agricultural and Livestock Research Organization (KALRO), Kitale, pp 54–67
- Ministry of Agriculture (MoA) (2005) Strategy for revitalizing agriculture 2004–2014. Ministry of Agriculture, Nairobi, Kenya, 23pp
- Ministry of Agriculture, Livestock and Fisheries (2018) Climate risk profile for Lamu County. Kenya County Climate Risk Profile Series. The Kenya Ministry of Agriculture, Livestock and Fisheries (MoALF), Nairobi, Kenya. 24pp. <https://hdl.handle.net/10568/9629>
- Monger W, Tomlinson J, Boonham N, Nielsen SL (2010) Development and inter-laboratory evaluation of real-time PCR assays for the detection of pospiviroids. *J Virol Methods* 169 (1):207–210
- Nartey F (1981) Cyanogenesis in tropical feeds and foodstuffs. In: Vennesland B (ed) Cyanide in biology. Academic Press, New York, 250pp
- Naskar SK, Singh DP, Srinivasan G (1989) Performance of cassava varieties in the laterite soils of Bhubaneswar and their yield stability. *J Root Crops* 15(1):29–31
- National Economic and Social Council of Kenya (NESC) (2007) Kenya vision 2030. Office of the President, Nairobi
- Nweke FI, Dixon AGO, Asadu CLA, Folayan SA (1994) Cassava variety needs of farmers and the potential for production growth in Africa. COSCA. Collaborative study of Cassava in Africa, COSCA Working Paper No. 10
- Nweke FI, Spencer DSC, Lynam JK (2002) Cassava transformation. International Institute of Tropical Agriculture, Ibadan, Nigeria, 273p
- Oendo M, DW Kilambya, PJ Ndolo (2001) Sweetpotato research priorities at the Kenya Agricultural Research Institute. Paper Presented at the Stakeholders Workshop for Sweetpotato Priority Setting, held at Machakos, Kenya, 27–28<sup>th</sup> September 2001, 19pp
- Odongo GO (2008) Analysis of level of toxicity (cyanogenic potential) of various cassava varieties and cassava based products. A Trade Project Report in the Kenya Polytechnic University College Department of Applied Science submitted to the Kenya National Examination Council in partial fulfilment of the requirements for award of Diploma in Food Technology, 35pp

- Onwueme IC (1978) The tropical tuber crops. Yams, cassava, Sweetpotato, Cocoyams. Wiley, Chichester, 234p
- Onyango C, Ngunjiri PW, Oguta TJ, Wambugu SM (2006) Small-scale processing technologies for selected traditional and horticultural food crops in Kenya. Kenya Industrial Research and Development Institute, Nairobi, Kenya, 166pp
- Rai M, Dhandar DG, Varma SP (1986) Variability studies of cassava varieties on growth and yield under tropical conditions. *J Root Crops* 12(1):25–28
- Tivana LD, Bvochora J (2005) Reduction of cyanogenic potential by heap fermentation of cassava roots. *Cassava Cyanide Diseases Network News*, Issue No. 6 2005, 1p

**Open Access** This chapter is licensed under the terms of the Creative Commons Attribution 4.0 International License (<http://creativecommons.org/licenses/by/4.0/>), which permits use, sharing, adaptation, distribution and reproduction in any medium or format, as long as you give appropriate credit to the original author(s) and the source, provide a link to the Creative Commons license and indicate if changes were made.

The images or other third party material in this chapter are included in the chapter's Creative Commons license, unless indicated otherwise in a credit line to the material. If material is not included in the chapter's Creative Commons license and your intended use is not permitted by statutory regulation or exceeds the permitted use, you will need to obtain permission directly from the copyright holder.





# Food Security Concerns, Climate Change, and Sea Level Rise in Coastal Cameroon

# 15

Wilfred A. Abia, Comfort A. Onya, Conalius E. Shum,  
Williette E. Amba, Karen L. Niba, and Eucharia A. Abia

## Contents

Introduction .....	262
Highlights of Coastal Cameroon .....	263
Coastal Zones and Risk Factors of Agricultural Productivity .....	264

---

This chapter was previously published non-open access with exclusive rights reserved by the Publisher. It has been changed retrospectively to open access under a CC BY 4.0 license and the copyright holder is “The Author(s)”. For further details, please see the license information at the end of the chapter.

---

W. A. Abia (✉)

Laboratory of Pharmacology and Toxicology, Department of Biochemistry, Faculty of Science, University of Yaounde 1, Yaounde, Cameroon

School of Agriculture, Environmental Sciences, and Risk Assessment, College of Science, Engineering and Technology (COSET), Institute for Management and Professional Training (IMPT), Yaounde, Cameroon

Integrated Health for All Foundation (IHAF), Yaounde, Cameroon

C. A. Onya

Natural Resources and Environmental Management, University of Buea, Buea, Cameroon

C. E. Shum · W. E. Amba

School of Agriculture, Environmental Sciences, and Risk Assessment, College of Science, Engineering and Technology (COSET), Institute for Management and Professional Training (IMPT), Yaounde, Cameroon

K. L. Niba

School of Agriculture, Environmental Sciences, and Risk Assessment, College of Science, Engineering and Technology (COSET), Institute for Management and Professional Training (IMPT), Yaounde, Cameroon

Integrated Health for All Foundation (IHAF), Yaounde, Cameroon

E. A. Abia

Integrated Health for All Foundation (IHAF), Yaounde, Cameroon

© The Author(s) 2021

W. Leal Filho et al. (eds.), *African Handbook of Climate Change Adaptation*,  
[https://doi.org/10.1007/978-3-030-45106-6\\_21](https://doi.org/10.1007/978-3-030-45106-6_21)

261

Climate Change and Sea Level Rise (CC/SLR) and Food Security in Coastal Cameroon . . . .	265
Climate Change and Coastal Areas . . . . .	265
Sea Level Rise (SLR) . . . . .	267
Climate Change and Sea Level Rise (CC/SLR) . . . . .	268
Conclusions and Future Prospects . . . . .	269
References . . . . .	270

## Abstract

Food security is a major public health priority in Cameroon, amidst climate change and sea level rise (CC/SLR), vis-à-vis the ever-increasing population growth with associated challenges. CC/SLR, singly or combine, is well known to have severe impacts on agricultural productivity, food security, socioeconomic activities and ecosystem (environment, plant and animal) health systems in coastal areas. They contribute to natural disasters including erosion, flooding, inundation of coastal lowlands, and saltwater intrusion, altogether reducing agricultural productivity. Additionally, these disasters provoke adverse animal, human, and environmental health implications; reduction in tourism; and potential close of some socioeconomic activities that constitute secondary (after agriculture), or main source of livelihood/income for many coastal indigents. Although there are inadequate reports on the impacts of CC/SLR, preliminary reports point to negative effects on crop production and socioeconomic activities in coastal Cameroon. This chapter highlights the susceptibility of coastal Cameroon agriculture and socioeconomic activities to CC/SLR. Furthermore, it has propose agricultural (CC/SLR and non-climatic) and educational intervention socioeconomic strategies for the mitigation and adaptation to CC/SLR and for sustainable agricultural productivity in coastal Cameroon. The proposed strategies may provide a small contribution toward a wider multi-stakeholder pool of strategies and which, when applied, may enhance food security in coastal Cameroon amidst CC/SLR and promote socioeconomic and touristic activities while reducing negative implications on animal, plant, human, and environmental health.

## Keywords

Agriculture · Climate change · Sea level rise · Food security · Ecosystem health

## Introduction

Food security is a major concern in feeding the world's estimated 9.8 billion people by 2050 (Worldometer 2020). The demand for food by 2050 will increase by an estimated 60%. This will be associated with broader economic and societal issues. Thus, there is increasing need for sustainable agriculture (Breene 2016; Abia et al. 2016; Center for Development Research (ZEF), Forum for Agricultural Research in Africa (FARA), Institute of Agricultural Research for Development (IRAD) 2017) toward sustainable food supply. Food security exists when all people, at all times,

have physical and economic access to sufficient safe and nutritious food that meets their dietary needs and food preferences for an active and healthy life (Food and Agriculture Organization (FAO) 2010). In addition, food security has three dimensions. These include (i) availability of food (which consist of three elements related to production, allocation, and exchange); (ii) access to food (that is connected with affordability, e.g., income and wealth, provision, and preferences); and (iii) utilization of food (focusing on the essential elements that are associated with dietetic and social values as well as food safety issues). Additionally, it is vital to ensure that the available and accessible food is safe. Furthermore, food waste should be minimized as much as possible (zero food waste concept. According to the Codex Alimentarius Commission (CAC 2003), food safety is the assurance that food will not cause harm to the consumer when it is prepared and/or eaten according to its intended use.

Food security is generally affected by several factors. Climate change remains one of the most devastating factors. Notwithstanding, both climatic and non-climatic factors, singly and collectively, hinder agricultural productivity. These factors include increase in temperature, fluctuation in rainfall (periods and amounts) and population growth, and sea level rise. Their effects on coastal agricultural productivity and sustainability may be a concern (Schiermeier 2018). They may provoke inundation, soil erosion, and saltwater intrusion (Gopalakrishnan et al. 2019).

In Cameroon, agriculture and food associated sectors provides employment to an estimated 75% of the adult-working population (mainly small-scale peasant farmers (NIS 2010), contributing 30% to the gross domestic product (GDP) and account for approximately half of total earnings from exports (DSCN 2002). The sustainability of the agricultural sector in Cameroon is essential (Abia et al. 2016) and sustaining the food sector (ZEF, FARA, IRAD 2017). However, there is inadequate focus on the limitations to the country's coastal agricultural productivity. Coastal Cameroon's agricultural productivity is likely already and may continue to experience adverse impacts of climate change and sea level rise (CC/SLR) especially in terms of area of inundation, soil erosion, flooding, salinity intrusion, and reduction in crop production. This may have serious repercussions on farmers, food security and safety, as well as on the ecosystem (plant, animal and human) health. An early awareness and preparation toward helping coastal farmers cope with CC/SLR is relevant. This chapter highlights the vulnerabilities of coastal Cameroon's agricultural productivity and ecosystem health to CC/SLR induced hazards, with proposed mitigation strategies.

---

## Highlights of Coastal Cameroon

The coastal lowlands of Cameroon is located between the Atlantic Ocean and the western highlands in the northeast and the south Cameroon plateau in the southeast and covers 402 km of coastline. The coastal Cameroon spans 15–150 km inland from the Gulf of Guinea with an average elevation of 90 m. The coastal zone of Cameroon has three sedimentary basins (Campo Kribi, Douala, and Rio-del Rey). These are known to be potentially rich in hydrocarbons and are currently being exploited by

petroleum companies. The northern part of the coast (including Idenau, Debundscha, Batoke, Bota, and Down Beach) is characterized by a small population size and very few industries and suffering impacts from the volcanic eruptions of Mount Cameroon. For example, during eruption, lava flows obstruct road networks, destroying crops, and induce rise in ocean water thereby killing fishes and other marine ecosystems. The coastal zone harbors the coldest place in Cameroon, Debundscha, which is at the foot of the Mount Cameroon, which experience the highest rainfall (annual average: 11,000 mm). The coastal region is characterized by equatorial climate with less dry (~3 months) and wet (~9 months) seasons alternating. The coastal line has high humidity mainly associated with the Guinea monsoon winds. The center of the coast, i.e., Douala, has an estuarine system of river Wouri and is the part with highest human/anthropogenic activities. Additionally, the central coast has the highest coastal population size and is home to approximately 60% of Cameroon's industries (Alemagi et al. 2006). It harbors the countries important industrial and environmental interests (Onguéné et al. 2015). The southern coast area (Kribi) harbors the smallest coastal population size and has few industries. The characteristics of coastal Cameroon have been presented variedly e.g., based on water, salt, and nutrient budget of the two estuaries (Gabche and Smith 2002) and based on characteristics of coastal vulnerability to climate change (Leal Filho et al. 2018).

---

## Coastal Zones and Risk Factors of Agricultural Productivity

Coastal areas are likely to be more vulnerable to climate change than inland areas because, in addition to changes in flooding, temperature, and precipitation, coastal lowlands are frequently affected by sea level rise (SLR) and sea wave heights. Increasing Greenhouse Gas (GHG) emissions may raise the average atmospheric temperature by 1.1 °C to 6.4 °C over the next century, with possible thermal expansion of the oceans, rapid melting of ice sheets, and consequently SLR (Intergovernmental Panel on Climate Change (IPCC) 2007a). On the average, the global SLR stood at the rate of 1.8 mm per year from 1961 to 1993 and at the rate of about 3.1 mm per year from 1993 to 2003 (IPCC 2007b). Even if GHG emissions were stabilized soon, thermal expansion and deglaciation would continue to trigger SLR for many decades. Furthermore, the continuous growth of GHG emissions and associated global warming could well promote SLR of 1–3 m in this century, and unexpectedly rapid breakup of the Greenland and West Antarctic ice sheets might produce a 5 m SLR (Church et al. 2001) and may rise to 7.5 m by 2020 (Bamber et al. 2019). Altogether, the IPCC Third Assessment Report of 2001 projected a global average SLR of between 20 and 70 cm between 1990 and 2100 using the full range of IPCC GHG scenarios and a range of climate models (IPCC 2001). Recently, SLR projection until 2030 was reported in the “Special IPCC Report on the Ocean and Cryosphere in a Changing Climate” (IPCC 2019). In the report, two scenarios for GHG emissions are considered: a “low” scenario (known as RCP2.6), with strong reduction of global greenhouse gas emission, such that global warming will probably not exceed 2 °C, and a “high” scenario (referred to as RCP8.5), in which no measures are taken to limit

GHG emissions. Altogether, it is assumed that the high scenario may lead to SLR of up to 5 m of the global average sea level in 2030 (IPCC 2019).

Coastal areas are generally vulnerable to anthropogenic influences such as dense population, industrialization, and agricultural activities (Amosu et al. 2012). In the west and central African sub-regions, erosion of beaches is among the major ecological problems (Ibe and Awosika 1991). Due to coastal erosion and SLR, the surface area of the coastal administrative capital of the Gambia, Banjul, may disappear within approximately 50–60 years, thereby jeopardizing livelihood for over 42,000 people (Jallow et al. 1999). SLR causes devastating effects, which could include loss of land, population displacement, loss of economic gain, loss of urban infrastructures and amenities, submersion of agricultural lands, wetlands (or biodiversity) loss, and even the disruption of several ecosystems (Dasgupta et al. 2009).

---

## Climate Change and Sea Level Rise (CC/SLR) and Food Security in Coastal Cameroon

Combined climate change (e.g., shifting weather patterns) and sea level rise (e.g., increase the risk of catastrophic flooding) (CC/SLR) has continued to threaten global agricultural production, socioeconomic activities and planetary health in an unprecedented manner for a while now, despite continuous efforts world over to mitigate it. There is urgent need for drastic actions, now more than ever; otherwise it will be more complex and expensive adapting to impacts of CC/SLR in the future (United Nations 2019).

SLR is generally referred to as “an increase in the level of the world’s oceans due to the effects of global warming.” Basically, a warming climate may cause seawater to expand and ice over land to melt. Both scenarios in combination may cause sea levels to rise (SLR). Thus, SLR is one of the major effect of climate change (CC), with rising waters threatening to inundate small-island nations and **coastal** regions in various parts of the world (Mimura 2013) and Cameroon (Fonteh et al. 2009). The effects of climate change, SLR, and both CC/SLR are discussed below.

## Climate Change and Coastal Areas

Among all the environmental challenges known to have overwhelmed the planet since the 1980s, it has been estimated that more than 70% of them are linked to climate change (Lambi and Kometa 2014). In the wake of natural disaster such as droughts, SLR, floods, tropical depressions as hurricanes, storms, and heat waves, there has been an overwhelming negative impact on humankind, the environment, and economic livelihoods (Living with Risk 2002; Associated Program on Flood Management 2009; Brown et al. 2013). Cameroon is exposed to the impacts of climate change particularly her territories located in the Sahelian zone (which are extremely threatened by effects of desertification) and coastal areas (that are highly vulnerable to SLR) (Banseka and Levesque 2018). Partly due to the impacts of

CC/SLR, coastal Cameroon is already facing extreme weather phenomena such as heavy rainfall, violent winds, high temperatures, and drought, which endanger communities' ecosystems and the services they provide (Molua 2006; Fonteh et al. 2009; Banseka and Levesque 2018).

The major risks of climate change are inundation, soil erosion, and saltwater intrusion (Gopalakrishnan et al. 2019) and which negatively affects agricultural productivity, with the worst impact in the coastal areas. Additionally, it is speculated that by 2080, coastal West Africa may experience a high-risk level of flooding provoked by climate change (Nicholls and Tol 2006).

In addition to the social and human costs, the economic cost of the impacts of climate change is immense. This includes decrease or losses in agricultural productivity due to droughts and increased variability of rainfall due to increased numbers and intensity of natural disasters such as SLR (Banseka and Levesque 2018). It is speculated that, if nothing is done to address climate change, the "cost of inaction" may be huge and is estimated to be between 5% and 20% of world GDP, whereas the cost of "acting" is estimated at only 1% or 2% (Stern 2006).

In order to contain the devastating effects and or influences of climate change on the environment, agricultural productivity, and ecosystem (animal, human, plant, environmental) health, which has jeopardized the entire planetary systems, two types of policy response measures are needed: mitigation (efforts to limit GHG emission) and adaptation (actions taken to reduce the negative consequences of changes in the climate).

Adaptation capacity designates the ability for society to plan for and respond to change in a way that makes it better equipped to manage its exposure and sensitivity to climate change. Nearly 2.4 billion people (about 40% of the world's population), live within 100 km on coastal strip around the globe, making a total of 60 miles of total land surface occupation per/inhabitant of the coastal strip. Thus, oceans coastal and marine resources are very important for people living in coastal communities, which represent 37% of global population (United Nations Factsheet 2017). The term coastal zone is a region where there is interaction of the sea and land processes, for example, the city of Limbe in the coastal Cameroon.

Globally, the most common adaptation and mitigation measures used is the "Ecosystems Based Adaptation" (EBA) approach. This involves the conservation, sustainable management, and restoration of ecosystems to adapt to the advert effects of climate change (Convention on Biological Diversity (CBD) 2009, 2018). This approach will help people to take into account, manage ecosystems in ways that permit them to adapt to climate change in coastal areas. The United Nations Environmental Program (UNEP) has laid-down foundation guides for EBA options under the UNEP building capacity for coastal EBA for small islands Development States (project funded by European Commission). This guide is a strategic resource geared at helping environmental and adaptation managers and planners, mainly in governmental departments and civil society organizations. It facilitates baselines knowledge and built broad understanding of the principles and concepts of coastal EBA (UNEP 2016).



In synopsis, “EBA implement and support, environmental decision makers in choosing, implementing, monitoring, evaluating and over time adaptively managing coastal areas.” Mangroves, coral reef, estuaries, seagrass beds, dune communities, and other systems on or near shorelines do serve critical ecological functions which are beneficial to human society. Some of these functions include fisheries, storm protection, floods mitigation, erosion control water storage, ground water recharge, pollution abatement, retention, and cycling of nutrients as well as sediments. In a similar manner, the Convention on Biological Diversity (CBA) has also acknowledged and recognized the potential importance of EBA in meeting this challenge (CBD 2009, 2018).

Around the globe, the coastal zone management Act (CZMA) introduced in 1972 is equally applicable. This sought to balance economic development with environmental conservation, mainly by avoiding the scenario of specifying a defensive definition approach to climate change management. The National as well as international CZMA programs encourage various countries of the globe to develop and implement CZMA plans to protect, restore, and develop the resources of their national coastal zones for present and future generations. A good number of states still recognize the importance pre-emptive action to address their vulnerability to climate change (C2ES 2011). Some mitigation innovations include beach nourishment, coastal fortification, and a reactionary approach which includes seawalls, groin and jetty construction, and inshore artificial reefs.

In Cameroon, the reality of climate change is widely acknowledged. It is the consequence of increasing temperatures caused by atmospheric GHGs, altering the functioning of the ecosystems. According to the Fourth Assessment Report of the IPCC, the efficiency is difficult to assess because of natural adaptation and non-climatic factors (IPCC 2007c). Furthermore, 70% of GHG emissions observed between 1970 and 2004 was caused by human activities (IPCC 2007a). The IPCC Synthesis Report suggests that a continuation of the present policies to mitigate climate change would probably lead GHG emissions to further in the coming decades (IPCC 2007d). Therefore, for improved and sustainable agricultural production, there is a need for continuous monitoring and forecasting and use of crops and varieties that are more resistant to drought and adaptation of suitable planting methods (Molua 2006). Furthermore, there is need for expansion of farm size, livelihood diversification, and usage of organic fertilizers as potential adaptation options (Epule and Bryant 2016). However, non-climatic factors such as deforestation, poor governance, inadequate access to farm inputs (e.g., fertilizers, increased economic opportunities elsewhere and a breakdown of cultural practices) cannot be minimized (Epule and Bryant 2016).

### **Sea Level Rise (SLR)**

The impact of sea level rise (SLR) on developing countries is overwhelming (Dasgupta et al. 2009). The effects will likely be more in coastal lowlands. SLR is expected to pose unique challenges partly due to the resultant saline contamination.

SLR may provoke more salt in soils and too much salt in soil can ruin crop yield (e.g., through restriction of water and nutrient uptake by the plant) and render farmlands or fields useless (Schiermeier 2018). SLR in coastal zones could potentially lead to land loss through inundation, erosion of coastal lands, increased frequency and extent of storm-related flooding, and increased salinity in estuaries and coastal freshwater aquifers (Gopalakrishnan et al. 2019).

Fonteh et al. (2009) have revealed possible implications of future SLR on the ecosystems and economic activities along the coast of Cameroon using mapping and valuation approaches. This was partly associated with the high ecological and economic value of the area. It was speculated that an estimated 112–1216 km<sup>2</sup> (1.2–12.6%) of the coastal area is likely to be lost from a 2–10 m (equivalent to a low scenario by 2050 and high scenario by 2100) flooding, respectively. Furthermore, approximately between 0.3% and 6.3% of ecosystems (estimated to worth US\$ 12.13 billion/year) could be at risk of flooding by the years 2050 and 2100. The areas under a serious threat contain mangroves, sea and airport, residential and industrial areas, and to a lesser extent, main plantation crops of banana and palms (Fonteh et al. 2009). Although there is inadequate information on the consequences, it may be speculated that this may have adverse effects on coastal agriculture production and may be a threat to food security and safety, as well as on the socio-economy of the coastal Cameroon. Wetland losses and loss of productive mangrove ecosystem will also occur with a SLR. According to the TOPEX/Poseidon and Jason satellite data, the rate of SLR in Cameroon is 2–2.4 mm/year between 1993 and 2004 (NASA 2008). Thus, the low-lying coastal areas are physically and socioeconomically vulnerable to impacts of SLR. There is need to take prompt actions toward mitigating the effects of SLR provoked natural disasters in coastal Cameroon (Fonteh et al. 2009).

## Climate Change and Sea Level Rise (CC/SLR)

Climate change and sea level rise (CC/SLR) are not new concepts, even though their synergistic effects seem minimized and less talked about vis-à-vis climate change or food security alone or in combination. SLR is a direct consequence of global climate change. It appears to get worst as population growth increases (Gommes and du Guerny 1998). The CC/SLR constitute a major hindrance to agricultural productivity (Schiermeier 2018; Ogbuabor and Egwuchukwu 2017) and may exert adverse effects on ecosystem health (Nicholls et al. 2011) in coastal areas.

As climate change continues to provoke SLR in coastal Cameroon, inundation of low-lying coastal areas increases continuously and with saltwater, and gradually contaminating the soil. Although rainfall can dissipate these salts, climate change is also increasing the frequency and severity of extreme weather events, including droughts and heat waves. This leads to intensive use of groundwater for drinking and irrigation, which further depletes the water table and allows salt to leach into soil. In some parts of the world, especially low-lying river deltas, local land is sinking (known as subsidence), making sea levels that much higher (Nicholls et al. 2007).

Thus, even without climate change, coastal areas such as coastal Cameroon would still experience slow relative SLR due to these non-climatic processes and hence increased flooding and damage cost through time (Nicholls 2002; Nicholls et al. 2007, 2011).

In addition to adverse impact on agricultural productivity, CC/SLR constitute a nuisance in coastal ecosystem health and socioeconomic activities. This is particularly worse in the developing countries with inadequate capacity to manage associated repercussions on land use, populations' evacuation/displacement and juxtaposition of livelihood sources, i.e., agriculture and touristic activities in the case of coastal Cameroon and elsewhere. For example, in coastal Cameroon, CC/SLR may lead to flooding which may provoke internal displacements with associated joblessness. The coastal Cameroon's situation is made worse by the eruption of Mt. Cameroon, which releases lava flow that further reduce agricultural land and destroy crops and marine lives whenever it erupts – a scenario which is arguably by the assumed post eruption increase in soil fertility. Apparently, coastal zones in different geographic areas, with varied anthropogenic activities, non-similar efforts against SLR, and varied effectiveness of erosion-driving forces such as waves and tides, are expected to react differently to SLR. Thus, considering the CC/SLR projected likelihood of high-risk flooding in the lowlands of coastal West Africa (including Cameroon) by 2080 (Nicholls and Tol 2006), there is a need for constant monitoring and timely mitigating actions to salvage coastal Cameroon from the natural disaster. To this effect, we speculate that relevant efforts to mitigate and adapt to CC/SLR may include intensive farmers' education on good agricultural practices, creation of nurseries for improved and climate smart food varieties, irrigation and vertical farming, and a shift from subsistence-to-industrial farming. Application of these strategies may enhance food security, ecosystem health and socioeconomic and touristic activities in the coastal Cameroon.

---

## Conclusions and Future Prospects

Food security is a major public health priority in Cameroon, vis-à-vis the ever-increasing population growth with associated challenges. Risk factors to agricultural productivity such as combined climate change and sea level rise (CC/SLR) require attention, particularly in coastal Cameroon. CC/SLR have negative impacts on agricultural productivity and socioeconomic activities in coastal morphology. This is through its contributions to natural disasters including erosion, flooding, inundation of coastal lowlands, and saltwater intrusion, which all have a significant impact on crop productivity and output. Socioeconomically, these disasters may provoke adverse animal, human, and environmental health implications; reduction in tourism; and potential close of some socioeconomic activities (e.g., beer parlors, and small roadside restaurants) that constitute as secondary (after agriculture), or main source of livelihood/income for many coastal indigents.

Sustainable agricultural productivity in Cameroon is essential, moreover in coastal Cameroon amidst CC/SLR. This requires concerted actions of stakeholders'

(government, local civil society organizations, individual, and common initiative farmers groups, and international bodies). Such efforts may propose and develop sustainable strategies toward adaptation and mitigation of risk factors of agricultural production and socioeconomic growth in coastal Cameroon. Potential adaptation options may span from agricultural (CC/SLR and non-climatic) to educational intervention socioeconomic strategies. CC/SLR strategies include expansion of farm size, usage of organic fertilizers, creation of nurseries for improved and climate smart crop varieties, irrigation and vertical farming, and a shift from subsistence-to-industrial farming. Non-climatic strategies may include afforestation, good governance, ensuring adequate access to farm inputs (e.g., fertilizers), promotion, and increase of local agribusiness opportunities. Educational intervention socioeconomic strategies may include intensive farmers' education on good agricultural practices, and the diversification of livelihood. These strategies may provide a small contribution toward a wider multi-stakeholder pool of strategies and which, when applied, may enhance food security in coastal Cameroon amidst CC/SLR and promote socioeconomic and touristic activities while reducing negative implications on animal, plant, human, and environmental health.

---

## References

- Abia WA, Shum CE, Fomboh RN, Ntungwe EN, Ageh MT (2016) Agriculture in Cameroon: proposed strategies to sustain productivity. *Int J Res Agric Food Sci* 2(2):1–12
- Alemagi D, Oben PM, Ertel J (2006) Mitigating industrial pollution along the Atlantic coast of Cameroon: an overview of government efforts. *Environmentalist* 26:41–50
- Amosu AO, Bashorun OW, Babalola OO, Olowu RA, Togunde KA (2012) Impact of climate change and anthropogenic activities on renewable coastal resources and biodiversity in Nigeria. *J Ecol Nat Environ* 4(8):201–211
- Associated Program on Flood Management (2009) Integrated flood management concept paper. Flood management policy series (World Meteorological Organization, WMO) No. 1047. Available online at: [http://www.apfm.info/pdf/concept\\_paper\\_e.pdf](http://www.apfm.info/pdf/concept_paper_e.pdf). Accessed 20 June 2020
- Bamber JL, Oppenheimer M, Kopp RE, Aspinall WP, Cooke RM (2019) Ice sheet contributions to future sea-level rise from structured expert judgment. *PNAS* 116(23):11195–11200. <https://doi.org/10.1073/pnas.1817205116>
- Bansekha H, Levesque LCT (2018) Cameroon: preparing the national adaptation plan for climate change (NAPCC) and its investment strategy (#492). In Gunya KJ, Philip R, Sara Oppenheimer S (eds) GWP global water partnership. Global Water Partnership (GWP), Stockholm, Sweden
- Breene K (2016) Food security and why it matters. Formative content. World Economic Forum. Available online at: <https://www.weforum.org/agenda/2016/01/food-security-and-why-it-matters/>. Accessed 22 Mar 2020
- Brown C, Meeks R, Ghile Y et al (2013) Is water security necessary? An empirical analysis of the effects of climate hazards on national-level economic growth. *Philos Trans R Soc A* 371:20120416. <https://doi.org/10.1098/rsta.2012.0416>
- C2ES (Center for Climate and Energy Solutions) (2011) Climate change 101: understanding and responding to global climate change: adaptation. Available online and accessed on 15.08.2020 at 03:20 at: <https://www.c2es.org/site/assets/uploads/2017/10/climate101-fullbook.pdf> and <https://www.c2es.org/document/climate-change-101-understanding-and-responding-to-global-climate-change/>
- CAC (Codex Alimentarius Committee of the FAO/WHO) (2003) Codex Alimentarius, basic text on food hygiene, 3rd edn. FAO, Rome

- Center for Development Research (ZEF), Forum for Agricultural Research in Africa (FARA), Institute of Agricultural Research for Development (IRAD) (2017) Country dossier: innovation for sustainable agricultural growth in Cameroon. Program of accompanying research for agricultural innovation. Center for Development Research, Forum for Agricultural Research in Africa and Institut de Recherche Agricole pour le Development, Bonn/Accra/Yaounde
- Church J, Gregory J, Huybrechts P, Kuhn M, Lambeck K, Nhuan M, Qin D, Woodworth P (2001) Changes in sea level. In: Houghton J, Ding Y, Griggs D, Noguer M, van der Linden P, Xiaosu D (eds) *Climate change 2001. The scientific basis*. Cambridge University Press, Cambridge, pp 639–693
- Convention on Biological Diversity (CBD) (2009) *Connecting biodiversity and climate change mitigation and adaptation: report of the second ad hoc technical expert group on biodiversity and climate change*. Technical series no. 41, Montreal, 126 p
- Convention on Biological Diversity (CBD) (2018) Decision adopted by the conference of the parties to the convention on biological diversity: 14/5 biodiversity and climate change. CBD/COP/DEC/14/5
- Dasgupta S, Laplante B, Meisner C et al (2009) The impact of sea level rise on developing countries: a comparative analysis. *Clim Chang* 93:379–388. <https://doi.org/10.1007/s10584-008-9499-5>
- Direction de la Statistique et de la Comptabilité Nationale (DSCN) (2002) *Conditions de vie des Populations et Profil de Pauvreté au Cameroun en 2001: Premiers resultats*. Direction de la Statistique et de la Comptabilité Nationale, Yaoundé
- Epule ET, Bryant RC (2016) Small scale farmers' indigenous agricultural adaptation options in the face of declining or stagnant crop yields in the Fako and meme divisions of Cameroon. *Agriculture* 6(2):22. <https://doi.org/10.3390/agriculture6020022>. Academic Editors: Annelie Holzkämper and Sibylle Stöckli (Special Issue Options for Agricultural Adaptation to Climate Change)
- FAO (2010) *The state of food insecurity in the world*. Food and Agriculture Organization of the United Nations, Rome
- Fonteh M, Esteves LS, Gehrels WR (2009) Mapping and valuation of ecosystems and economic activities along the coast of Cameroon: implications of future sea level rise. *Int Approaches Coast Res Theory Pract Coastline Rep* 13:47–63
- Gabche CE, Smith VS (2002) Water, salts and nutrient budgets of two estuaries in the coastal zone of Cameroon. *West Afr J Appl Ecol* 3:69–89
- Gommes R, du Guerny J (1998) Potential impacts of sea-level rise on populations and agriculture. *Climate change in Food and Agriculture Organization of the United Nations*. Available online at: [http://www.fao.org/nr/climpag/pub/EIre0045\\_en.asp](http://www.fao.org/nr/climpag/pub/EIre0045_en.asp). Accessed 16 Mar 2020
- Gopalakrishnan T, Hasan MK, Haque ATMS, Jayasinghe SL, Kumar L (2019) Sustainability of coastal agriculture under climate change. *Sustainability* 11:7200. <https://doi.org/10.3390/su11247200>
- Ibe AC, Awosika LF (1991) Sea level rise impact on African coastal zones. In: Omide SH, Juma C (eds) *A change in the weather: African perspectives on climate change*. African Centre for Technology Studies, Nairobi, pp 105–112
- Intergovernmental Panel on Climate Change (IPCC) (2001) *Climate change 2001: the physical science basis*. In: Houghton JT, Ding Y, Griggs DJ, Noguer M, van der Linden PJ, Xiaosu D (eds) *Working group I contribution to the third assessment report of the Intergovernmental Panel on Climate Change (IPCC)*. Global Water Partnership (GWP), Stockholm, Sweden
- Intergovernmental Panel on Climate Change (IPCC) (2007a) *Climate change 2007 – mitigation of climate change contribution of working group iii to the fourth assessment report of the IPCC* (978 0521 88011-4 Hardback; 978 0521 70598-1 Paperback)
- Intergovernmental Panel on Climate Change (IPCC) (2007b) *Climate change 2007 – the physical science basis contribution of working group I to the fourth assessment report of the IPCC* (ISBN 978 0521 88009-1 Hardback; 978 0521 70596-7 Paperback)
- Intergovernmental Panel on Climate Change (IPCC) (2007c) *Climate change 2007 – impacts, adaptation and vulnerability contribution of working group II to the fourth assessment report of the IPCC* (978 0521 88010-7 hardback; 978 0521 70597-4 paperback)

- Intergovernmental Panel on Climate Change (IPCC) (2007d) Climate change 2007: synthesis report. In: Core Writing Team, Pachauri RK, Reisinger A (eds) Contribution of working groups I, II and III to the fourth assessment report of the intergovernmental panel on climate change. Global Water Partnership (GWP), Stockholm, Sweden
- Intergovernmental Panel on Climate Change (IPCC) (2019) Special report on the ocean and cryosphere in a changing climate. In: Pörtner H-O, Roberts DC, Masson-Delmotte V, Zhai P, Tignor M, Poloczanska E, Mintenbeck K, Nicolai M, Okem A, Petzold J, Rama B, Weyer N (eds). In press. <https://www.ipcc.ch/srocc/cite-report/>
- Jallow BP, Toure S, Barrow MMK, Mathieu AA (1999) Coastal zone of the Gambia and the Abidjan region in Cote d'Ivoire: sea level rise vulnerability, response strategies, and adaptation options. *Clim Res* 12(2):129–136. <https://doi.org/10.3354/cr012129>
- Lambi CM, Kometa SS (2014) Climate change in Cameroon and its impacts on agriculture. In: Albrecht E, Schmidt M, Mißler-Behr M, Spyra S (eds) Implementing adaptation strategies by legal, economic and planning instruments on climate change. Environmental protection in the European Union, vol 4. Springer, Berlin/Heidelberg
- Leal Filho W, F M, Nagy GJ et al (2018) Fostering coastal resilience to climate change vulnerability in Bangladesh, Brazil, Cameroon and Uruguay: a cross-country comparison. *Mitig Adapt Strateg Glob Chang* 23:579–602. <https://doi.org/10.1007/s11027-017-9750-3>
- Living with Risk (2002) A global review of disaster reduction initiatives. International Strategy for Disaster Reduction (ISDR), Geneva. Accessed at: <http://helid.digicollection.org/en/d/Js2653e/>
- Mimura N (2013) Sea-level rise caused by climate change and its implications for society. *Proc Jpn Acad Ser B Phys Biol Sci* 89:281–301
- Molua EL (2006) Climatic trends in Cameroon: implications for agricultural management. *Clim Res* 30:255–262. <https://doi.org/10.3354/cr030255>
- National Aeronautics and Space Administration (NASA) (2008) Ocean surface topography from space. Californian Institute of Technology: Jet Propulsion Laboratory, Pasadena, California
- National Institute of Statistics (NIS) (2010) The population of Cameroon: reports of the presentation of the final results of the 3rd general census of population and habitats (RGPH): Central Bureau of Census and Population Studies. National Institute of Statistics, Ministry of the Economy and Finance, Yaounde
- Nicholls RJ (2002) Analysis of global impacts of sea-level rise: a case study of flooding. *Phys Chem Earth Parts A/B/C* 27(32):1455–1466. [https://doi.org/10.1016/S1474-7065\(02\)00090-6](https://doi.org/10.1016/S1474-7065(02)00090-6)
- Nicholls RJ, Tol RSJ (2006) Impacts and responses to sea-level rise: a global analysis of the SRES scenarios over the twenty-first century. *Philos Trans R Soc A* 364:1073–1095
- Nicholls RJ, Wong PP, Burkett VR, Codignotto JO, Hay JE, McLean RF, Ragoonaden S, Woodroffe CD (2007) Coastal systems and low-lying areas. In: Pary ML, Canziani OF, Palutikof JP, van der Linden PJ, Hanson CE (eds) Climate change 2007: impacts, adaptation and vulnerability. Contribution of working group II to the fourth assessment report of the intergovernmental panel on climate change. Cambridge University Press, Cambridge, UK, pp 315–357
- Nicholls RJ, Marinova N, Lowe JA, Brown S, Vellinga P, de Gusmão D, Hinkel J, Tol RSJ (2011) Sea-level rise and its possible impacts given a 'beyond 4°C world' in the twenty-first century. *Phil. Philos Trans R Soc A* 369:161–181. <https://doi.org/10.1098/rsta.2010.0291>
- Ogbuabor JE, Egwuchukwu EI (2017) The impact of climate change on the Nigerian economy. *Int J Energy Econ Policy*, *Econjournals* 7(2):217–223.
- Onguéné RE, Pemha E, Lyard F, Penhoat Y, Nkoue G, Duhaut T, Ebénézer N, Marsaleix P, Mbiaké R, Jombe S, Allain D (2015) Overview of tide characteristics in Cameroon coastal areas using recent observations. *Open J Mar Sci* 05(1):81–98. <https://doi.org/10.4236/ojms.2015.51008>
- Schiermeier Q (2018) Droughts, heatwaves and floods: how to tell when climate change is to blame. *Nature* 560:20–22
- Stern N (2006) The economics of climate change. Cabinet office – HM treasury. Cambridge University Press, London
- United Nations (UN) (2019) Climate change – United Nations. Available online at the DRIP POT SHOP: <https://www.drippot.ca/blogs/climate-change-united/climate-change-united-nations>. Accessed 16 Mar 2020

United Nations Environmental Program (UNEP) (2016) Options for ecosystem-based adaptation (EBA) in coastal environments: a guide for environmental managers and planners. UNEP, Nairobi

Worldometer (2020) Africa population forecast. Source: Worldometer ([www.Worldometers.info](http://www.worldometers.info)). Available online and consulted on 07 Mar 2020 at: <https://www.worldometers.info/world-population/africa-population/>

**Open Access** This chapter is licensed under the terms of the Creative Commons Attribution 4.0 International License (<http://creativecommons.org/licenses/by/4.0/>), which permits use, sharing, adaptation, distribution and reproduction in any medium or format, as long as you give appropriate credit to the original author(s) and the source, provide a link to the Creative Commons license and indicate if changes were made.

The images or other third party material in this chapter are included in the chapter's Creative Commons license, unless indicated otherwise in a credit line to the material. If material is not included in the chapter's Creative Commons license and your intended use is not permitted by statutory regulation or exceeds the permitted use, you will need to obtain permission directly from the copyright holder.





# Impacts of Climate Change to Poultry Production in Africa: Adaptation Options for Broiler Chickens

# 16

M. O. Abioja and J. A. Abiona

## Contents

Introduction .....	276
Climate Change and Its Evidences in Africa .....	277
Impacts of Climate Change to Poultry Production .....	278
Direct Impacts .....	279
Indirect Impacts .....	280
Broiler Production .....	280
Heat Stress and Broiler Chickens .....	281
Negative Effects of Heat Stress in Broiler Chickens .....	282
Adaptation Options to Climate Change for Broiler Chickens .....	283
Housing System and Climate Amelioration .....	283
Feed and Feeding Manipulations .....	285
Water Supply .....	286
Stocking Density .....	287
Epigenetic Adaptation to Thermal Assaults .....	288
Use of Honey and Other Natural Phytochemicals .....	289

This chapter was previously published non-open access with exclusive rights reserved by the Publisher. It has been changed retrospectively to open access under a CC BY 4.0 license and the copyright holder is “The Author(s)”. For further details, please see the license information at the end of the chapter.

**Electronic supplementary material:** The online version of this chapter ([https://doi.org/10.1007/978-3-030-45106-6\\_111](https://doi.org/10.1007/978-3-030-45106-6_111)) contains supplementary material, which is available to authorized users.

M. O. Abioja (✉) · J. A. Abiona

Department of Animal Physiology, College of Animal Science and Livestock Production, Federal University of Agriculture, Abeokuta, Nigeria

e-mail: [abiojamo@funaab.edu.ng](mailto:abiojamo@funaab.edu.ng); [abionaja@funaab.edu.ng](mailto:abionaja@funaab.edu.ng)

© The Author(s) 2021

275

W. Leal Filho et al. (eds.), *African Handbook of Climate Change Adaptation*,  
[https://doi.org/10.1007/978-3-030-45106-6\\_111](https://doi.org/10.1007/978-3-030-45106-6_111)



Breeding for Thermotolerant Strains in Africa .....	291
Others Adaptation Options .....	292
Conclusion .....	292
References .....	292

## Abstract

Global climate change poses a great threat to poultry production. Greenhouse gases (GHGs) are released through both natural and anthropogenic sources into the atmosphere. Though poultry production contributes little to the release of GHGs, the subsector has been shown to be greatly affected by climate change and global warming. Poultry production as a major subsector of agriculture has provided the teeming population with a supply of needed animal protein in terms of meat and egg production all over the world. It is yet a major global employer of labor. Though it occupies a vantage position in meeting human needs, it is being threatened by climate change, especially in Africa where necessary structure to tackle the menace is nonexistent. Broiler chickens that are reared mainly for chicken meat cannot tolerate the high ambient temperature that prevails mostly in the tropical environment. Chickens are homeotherms that homeostatically regulate core body temperature within a narrow range. Elevated ambient temperature above thermal comfort zone, such as envisaged in climate change scenarios, will trigger series of neuroendocrine modulations that are detrimental to the welfare and productivity in broiler chickens. Such birds are said to be undergoing heat stress (HS). Negative effects of HS include reduced feed consumption, growth rate, feed digestion and efficiency, immunity, welfare, and survivability. Various adaptive measures that could be harnessed by broiler farmers, ranging from housing, feeding, watering, stocking, breeding for thermo-tolerant strains, thermal conditioning, use of phytochemicals, and much more, are reviewed upon in this chapter.

## Keywords

Acclimation · Acclimatization · Broiler chickens · Environmental temperature · Heat stress · Thermal comfort zone · Thermoregulation

## Introduction

Climate change is defined by Ngaira (2007) as deviations in the patterns of climate over a long period of time while the Intergovernmental Panel on Climate Change (IPCC) recognized it as a change in the state of the climate that can be identified (using statistical tests) by changes in average and standard deviation, and that persists for a long period of time, typically more than one decade or longer (IPCC 2007). It poses a great threat to agricultural and socioeconomic development (Niang et al. 2014). The problem of climate change will add to the burden of heat stress (HS) usually experienced in the tropical regions of Africa because of

the predicted increase in global temperature. Though Africa contributes the least of the global GHG emission, yet evidences had shown that most developing countries in Africa would be the most affected because of low infrastructural capacity to cope. This is also hinged on the fact of widespread poverty, prevailing slash-and-burn agriculture, erosion, and burning of firewood and farm residues. The problem of desert encroachment and deforestation is also a contributory factor to climate change. All facets of human life will be affected by climate change. Poultry production, a subsector of agriculture that had helped in supplying the needed human protein requirements from chicken, turkey, duck, guinea fowl, geese, and ostrich is not spared. Productivity and welfare of poultry species in Africa will be negatively impacted upon by climate change. Chicken being the most populous and important among poultry species will be most impacted upon. Global chicken population was over 22 billion in 2017. Broiler chickens, raised mainly for meat production with high feed-to-meat conversion efficiency, is the most sensitive to the effects of elevated temperature in the environment among other strains of chickens. Its productivity is grossly affected once the required environmental conditions, especially temperature, are compromised. These necessitate the development of a review of all available options for adaptation of broiler production to the prevailing and envisaged global warming.

---

## Climate Change and Its Evidences in Africa

Livestock subsector was viewed as a victim until it was implicated as a major contributor to global emission of greenhouse gases (GHGs) such as CO<sub>2</sub> and CH<sub>4</sub>. FAO's report *Livestock's Long Shadow* opened up the minds of many stakeholders to this fact (FAO 2006) that the subsector contributes 18% of global GHGs. These gases cause warming of the globe by entrapping heat on the earth crust not allowing it to be reflected to the atmosphere. Resultant global warming and climatic variability have been reported to have both direct and indirect impacts on livestock production, including reduced growth and reproductive efficiency, low quality and quantity of feed materials, and increased prevalence of disease due to rise in temperature (Renaudeau et al. 2012). Africa is the most threatened all over the world with predicted effects of climate change (Ngaira 2007). Though, the continent is the least emitter of these GHGs of all continents, unlike other industrialized nations that are emitting these in tonnes daily.

Predicted temperature rise of 2–6 °C is expected over the land of Africa within the next 100 years and a rise of 1.5–3.0 °C by 2050. This is much more severe than experienced in other regions. The presence of climate change in Africa is evident in that the three warmest years over African land since 1950 had been identified as 2010, 2016, and 2017, all occurring within the last decade. Average deviation from the mean temperature of 1961–1990 was +1.41, +1.26, and + 1.20 °C, respectively. The warming rate per century recorded in Africa (+3.7 °C) is an alarming signal. ACMAD (2017) stated that temperature anomalies varied over the different

subregions of Africa in 2017. Northern Africa experienced the average temperature anomaly was 1.1 °C warmer than the long-term mean. Similar to the experience in the North Africa, 2017 had temperature anomaly of 1.2 °C above average over the West African region. Central Africa had a temperature anomaly of 1.3 °C above average. Over Eastern Africa land, 1.2 °C was recorded above average while anomaly of 1.0 °C above average was reported over the Southern Africa region in 2017. However, temperatures in 2017 were mild over the island countries in the Indian Ocean. For instance, one of the coldest years in Madagascar is 2017, with temperature deviation of 0.3 °C below the mean. Climate change will pose considerable risks to the livelihood of the dwellers of most countries in Africa that mainly depend on agriculture (Hummel 2015).

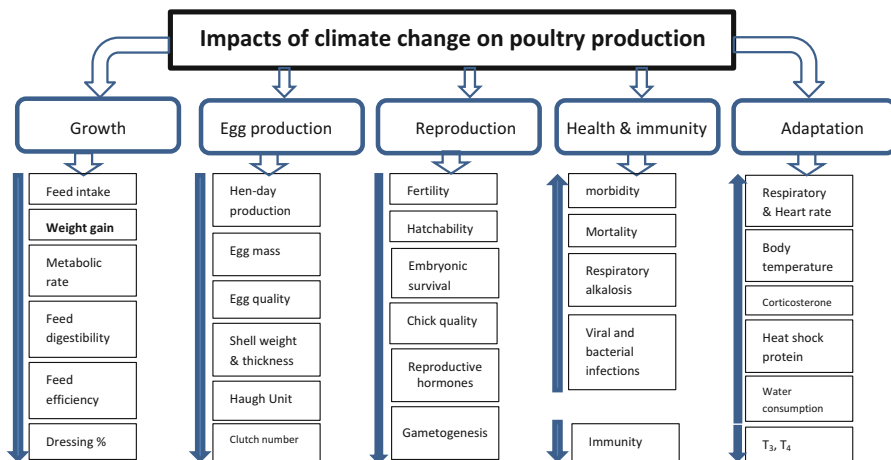
Poultry farmers in Africa are aware of climate change because many of them have been taken cognizance of variability in rainfall amount and pattern, heat spells, and variability in other climatic elements. Indigenous technical knowledge and systems that had been explored by farmers in adapting to high environmental temperature abounds.

---

## Impacts of Climate Change to Poultry Production

In Africa, there are two main poultry production systems. Distinguishing factors between the two are associated with the scale of production, stock, management system, and productivity. The two systems are the commercial poultry and the rural poultry. The former is on large to medium scale, stocking improved/exotic breeds, reared intensively with adequate care for feeding, health, and welfare of the birds in modern facilities in large number. In terms of productivity, the commercial gives higher returns. On the other hand, the latter, *also known as* village or backyard poultry, is usually on small scale, stocking the locally adapted indigenous breeds of birds. The productivity is lower with the village poultry system. In history, the latter is far older than the former. Meanwhile, intermediate system between the two systems has evolved over time. Commercial poultry system includes breeding farms where grandparent (GP) and parent stocks are raised. Day-old chicks (broiler and layer lines) are produced by the breeding farms. Commercial broiler farms raise the chicks till table size of around 2.5 kg in 6–8 weeks. The effort to genetically improve commercial stocks of broiler chickens began in earnest in the USA in the 1940s (FAO 2020). And since then, it has been the stories of great leaps in improvement of growth rate and feed conversion efficiency. The successful breeding company started exporting chicken hybrids with improved strains into African countries in the 1950s. This coincided with the rapid development of commercial poultry systems in Africa.

All these systems are under the threats of the climate change but the most affected of them is the commercial poultry system. Impacts of climate change on poultry production (Fig. 1) could be categorized into two.



**Fig. 1** Diagram illustration the effects of climate change on poultry production

## Direct Impacts

Climate change has impacts on poultry production by way of imposing stress on the homeostasis in the birds. It may come in the form of extreme climatic situations: elevated temperature, flood or drought, and water scarcity (Tiruneh and Tegene 2018). Common among these is increased global temperature. Extreme weather conditions lead to production losses (reduced growth rate, lowered egg hen-day production, and increased morbidity and mortality) in poultry birds (Attia et al. 2011). Poultry birds can adapt to hot environment. However, the mechanisms of coping subject the birds to losses and diversion of nutrients meant for production to thermoregulation.

Growth performance of the birds is grossly affected by perturbations in weather conditions in the surroundings. The most important of these is the pen temperature. Changes in humidity work synergistically with high environmental temperature to impact negatively on poultry birds. In hot environment, feed consumption is reduced in order to limit metabolic heat production. Available nutrients in the system are utilized for heat loss mechanisms instead of profitable usage for muscle accretion. Digesta mobility in the gastrointestinal tract (GIT) is drastically reduced and efficiency of nutrient digestion and assimilation in the intestines is lowered. Histomorphometric studies show that the epithelial cells of the intestines are affected by HS (Santos et al. 2015). Vasodilation of blood vessels at the periphery reduces blood flow across GIT of the birds thereby lowering the efficiency of digestion and nutrient uptake. All these factors cumulatively contributed to the lowered final liveweight and dressing percentage usually obtained in heat-stressed chickens (Syafwan et al. 2011).

Productivity in laying chickens is negatively affected by elevation in temperature by reducing the number and size of eggs produced. Internal and external quality traits of the eggs are compromised by changes in weather conditions around the

birds. High ambient temperature lowers egg fertility, hatchability, and chick quality in breeder stocks (Ayo et al. 2011). Impact of climate change will be felt on the synthesis and the release of reproductive hormones (FSH, LH, progesterone, estrogen, and testosterone) with resultant reduction in efficiency of gametogenesis in male (spermatogenesis; Al-Saffar and Rose 2002; Karaca et al. 2002) and female (oogenesis) birds (Rozenboim et al. 2007). Heat-stressed cocks produce semen with low sperm concentration and quality. Immunity of the birds is lowered under HS conditions (Calefi et al. 2017).

## Indirect Impacts

Indirectly, climate change will impact on feed ingredient availability and quality for the poultry birds; availability of adequate good quality water; and pest and diseases infestation in Africa. Climate has effects on the yield and quality of produce of crop husbandry from where most of the feed ingredients are sourced. Feed ingredients such as maize, groundnut cake, cotton-seed cake, wheat offal, and rice bran are gotten from agronomic activities. Semiarid regions experiencing low rainfall amount and irregular pattern cannot boast of bountiful harvest. This may trigger skyrocketing of the feed price for poultry species and exacerbate the animal-human competition for feed materials except irrigation systems are employed. Rain-fed cropping in the forest vegetation will also be affected by high temperature and insufficient rainfall.

Availability of adequate good quality water is essential to productivity in poultry production. Climate change has reared up its head in reduction in water in the ponds, streams, rivers, and the seas immediately after rainy season all around Africa because of increased rate of evaporation (Alemayehu and Woldeamlak 2017). Water shortage adversely affects body weight and lymphoid organs (Mustafa et al. 2010). Changes in the existing pattern of pest and disease infestations are envisaged under different climatic change scenarios. This will affect productivity of poultry in terms of morbidity, mortality, and the cost of vaccinations and medications.

---

## Broiler Production

Broiler chickens are reared mainly for meat production. The production cycle lasts for 5 to 8 weeks, with high rate of turn-over of feed to meat from day-old chicks to market age. Chicks are obtained from specialized lines called breeder chickens. At market age, the liveweight of 40–55 g at day-old would have multiplied by 50 times to give about 2.5 kg chickens. Both male and female sexes of broiler chickens are reared for meat, though male chickens grow faster than the female counterparts. Most of the strains of broiler chickens reared in Africa are developed in the temperate regions of the world such as the USA and the Netherlands but are imported into Africa. The birds are incapable of expressing the inherent growth potentials because of HS and the productivity is often below what is obtainable in their counterparts in the cooler climes. Broiler chickens are sensitive to elevation in ambient temperature during growing

phase. Production and demand for chicken meat has increased tremendously worldwide over the last few decades. This results from different selection and cross-breeding techniques that are employed to improve growth rate of broiler chickens, reaching market weight within a short span of time than what is obtained in the past. To continue enjoying the gains of several years of broiler development, efforts toward ensuring adaptation of broiler chickens to prevailing high environmental temperature expected in climate change are worthwhile.

## Heat Stress and Broiler Chickens

All farm animals in the tropical region suffer from HS at one time or the other because of constant elevated ambient temperature (Altan et al. 2000). People and livestock in the temperate regions are exposed to HS induced by elevated environmental temperature during summer. HS is an adaptive response that occurs in a bird when the rate of thermolysis is below thermogenesis and the ability to lose body heat exceeded by the heat load acquired through exposure to high ambient temperature (Al-Saffar and Rose 2002).

Broiler chickens are homeothermic animals capable of maintaining the body temperature within a narrow range irrespective of the environmental temperature. They possess an internal homeostatic mechanism that regulates internal body temperature. The internal body temperature of adult chicken is normally between 41.2 °C and 42.2 °C (Mitchell et al. 2005). Newly hatched birds have a body temperature approximately 2–3 °C below that of the adult birds. Additional source of warmth is needed by the chicks during the first 21 days post-hatch to maintain body temperature for normal growth and development. However, as the birds increase in age and size, their requirement for supplemental heat declines. This results from the development of insulating feathers, higher metabolic heat production, and maturation of the thermoregulatory system of the birds. In general, the thermal comfort or thermoneutral zone (TNZ) for broilers declines from about 32 °C at hatching to around 24 °C at 3 to 4 weeks of age and to about 21.1 °C thereafter. The birds at this period are capable of heat regulation to maintain core body temperature. As temperature increases beyond 21.1 °C around adult chickens, mechanisms for heat loss are triggered.

The fast-growing broiler lines are susceptible to high temperature mostly during growing-finishing phase. The high susceptibility to HS results from resultant inferior development of their cardiovascular and respiratory systems (Yahav 2000). As well, chickens do not possess sweat glands (Mitchell et al. 2005). In addition, their rapid growth rate is supported by high feed intake, thus, as they grow, metabolic heat production increases but their heat dissipation capacity does not. Broiler chickens gain heat from metabolism, physical activity, and environment. This heat load must be dissipated to maintain constant body temperature. Metabolic heat production in broilers is particularly high because of their high feed intake compared to other strains of chickens. Their growth rate is supported by feed consumption which leads to generation of heat in the body system. Increased heat production does not have

**Fig. 2** Diagram showing broiler chicken exhibiting panting behaviour



any adverse consequence on the birds in TNZ and cold environments. But as ambient temperature overshoots the upper limit of the TNZ, the ability of the bird to dissipate heat is compromised making excessive heat production built-up. The condition leads to hyperthermia (increased core body temperature) which is potentially life threatening. Before this stage, the body temperature is regulated mainly by loss of heat to outside environment through conduction, convection, and radiation, *also known as* non-evaporative heat loss. Effectiveness of these three means of heat loss is limited to lower temperatures (Borges et al. 2003).

As the temperature peaks, chickens exhibit panting, an evaporative heat loss behavior (Fig. 2; Video 1). Panting involves evaporative cooling of the bird by losing heat from the respiratory tract. They also display wing-raising to expose the poorly feathered sides of the body and under-wing area. Sometimes, they dig into the litter to sit on a cooler floor in the pen during hot periods. Panting occurs when the deep body temperature of poultry reaches 42 °C. Respiratory rate may increase from 25 to 150 breaths per minute over a 20-min period in response to an increase in ambient temperature from TNZ. In a healthy chicken, hyperventilation through panting will remove approximately 0.54 Kcal/g water lost in the lungs. Chickens increase saliva secretion during this period because of the need to the surface of the respiratory tract wet during panting.

### **Negative Effects of Heat Stress in Broiler Chickens**

The adverse effects of HS can be seen in decreased feed consumption, increased water intake, rise in body temperature, respiratory rate, heart rate, electrolyte

imbalance, changes in hematological parameters, hormone levels and enzymatic activities, and perturbations in blood *pH* (respiratory alkalosis; Lara and Rostagno 2013). All these negatively affect productivity of the animal. An increase in body temperature above the regulated range, because of exposure to hot environmental conditions, may lead to a cascade of irreversible thermoregulatory events that may be lethal for the birds. Generally, broiler chickens try to lower its heat production by reducing its feed consumption during heat episodes. The reduction in feed consumption can be as high as 1.5% per 1 °C increase in temperature above TNZ. Reduction in feed consumption consequentially leads to insufficiency of essential nutrients. Coupled with this is the lowered digestibility of feed in the gastrointestinal tract of the birds. Growth rate is therefore reduced in broiler birds when environmental temperature rises because even the little energy obtained from the small feed consumed is expended in panting. The result is that birds had lower final body weight. Chronic HS increases the time to reach market weight and impairs feed digestibility. More feed is required to lay down unit weight of chicken than in TNZ conditions. Exposure to hot weather leads to high mortality in broilers and loss of immunity. Efforts to increase feed consumption during HS by force-feeding have been shown to decrease survival. Mortality in broilers up to 10% of the total production has been reported during HS. Egg production, fertility, and hatchability are said to be grossly affected in both grandparent and parent (broiler breeder) stocks. Time expected for feeding is expended in panting and beside water troughs. Birds consume more water during HS exposure. Excessive loss of CO<sub>2</sub> in exhaled air during panting results in high blood *pH*, a syndrome called *respiratory alkalosis*.

---

## Adaptation Options to Climate Change for Broiler Chickens

### Housing System and Climate Amelioration

Ideal broiler chicken environment must meet the requirement of the birds for adequate pen temperature, relative humidity, and air circulation. Broiler houses are closed system in most industrialized countries where the temperature and humidity are fully controlled, unlike in developing countries where open-sided housing units are common. Foggers, tunnel ventilators, fans, and misters are used to cool the environment in closed systems. However, the cost of installing and maintaining fans, foggers, ventilators, misting pumps, and so on in poultry houses is often beyond what most farmers can afford.

Attaining the optimal range of climatic variables in the open-sided poultry houses common in the tropics is difficult and almost impossible (Abioja 2010). However, proper ventilation is essential in minimizing the effect of heat in African poultry housing units. As the higher environmental temperature is expected all over Africa, the following should be considered for broiler housing:



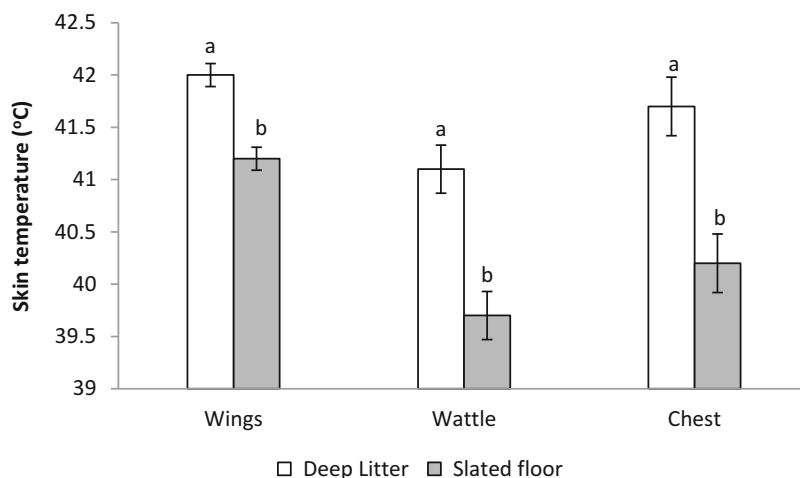
- Orientation of the housing units should allow for cross-ventilation.
- Low-walled structures completed with wire mesh to ensure cross-ventilation (Fig. 3). High walled structures trap heat inside and will not be applicable.
- Mud wall houses provide cooler interior than brick wall housing unit.
- Roofing style should be such that allow for proper ventilation.
- Roofing materials must be considered. Asbestos roof is preferred to corrugated iron sheet. Local materials that enable heat transfer such as palm fronds, long grasses such used for thatched roof could be used.
- Tree planting around broiler housing units will provide coolness (Fig. 4).
- The use of mobile pens with wire mesh floor placed under shade of trees.



**Fig. 3** Low-walled broiler housing units



**Fig. 4** Tree shade beside broiler housing unit



**Fig. 5** Effect of floor type on skin temperature of broiler chickens during hot-dry season

**Table 1** Effect of floor type on rectal temperature, respiratory rate, heart rate, and skin temperature in broiler chickens during hot season

Parameter	Floor		<i>p</i>
	Deep-litter	Wire mesh	
Rectal temperature, °C	42.7 ± 0.07 <sup>a</sup>	42.0 ± 0.07 <sup>b</sup>	0.000
Respiratory rate, breaths/min	138.8 ± 2.28 <sup>a</sup>	125.3 ± 2.28 <sup>b</sup>	0.000
Heart rate, beats/min	198.4 ± 2.96 <sup>a</sup>	188.6 ± 2.96 <sup>b</sup>	0.023

<sup>a, b</sup>Means within the same row with different superscripts differ significantly ( $P < 0.05$ )

Broiler chickens are commonly raised on deep-litter floor in most areas of the world, but the use of cage for broiler is becoming common (Shields and Greger 2013). Type of floor has been reported to influence liveweight, feed intake, protein efficiency, and feed conversion ratio in broiler birds reared during winter and summer (Simsek et al. 2014). Wire mesh floor decreased skin temperature, cloacal temperature, respiratory rate, and heart rate of broiler chickens compared to deep-litter floor during hot season (Fig. 5, Table 1; Abioja 2020 –*Unpublished data*).

## Feed and Feeding Manipulations

Special attention should be given to the nutrition of broiler birds under high temperatures expected under climate change. The major problem of broiler chickens under HS conditions is the fact of reduction in feed consumption. Reduced dietary intake limits available metabolizable energy to sustain normal output. The following suggestions may be of help in feeding broilers during heat spells:

- More energy should be delivered in the form of fat instead of starch (because heat increment from metabolizing fat is lower than that from carbohydrate however rancidity of fat should be given a consideration).
- Balancing of amino acids in the diet especially methionine and lysine is necessary to augment for deficiencies resulting from low protein intake.
- Diets with low protein level should be recommended in order to reduce heat production in broiler chickens under HS because protein has the highest heat increment of all nutrients.
- Anti-oxidant vitamins (A, C, and E) supplementation has also been credited to improve performance of broilers during HS.
- Wet feeding (Awojobi et al. 2009; Dei and Bumbie 2011) was found to help in improving the final liveweight and weight gain of the birds in a hot climate. Syafwan et al. (2011) stated in a review on HS and feeding strategies in meat-type chickens that wet feeding may be profitable under HS conditions. Feeding wet diets might facilitate an increased water intake. This ensures availability of adequate water for evaporation during panting, hence helping cooling of the bird.

Other areas to be considered for adaptation of broiler chickens to climate change include feeding time (Farghly et al. 2019). Feeding time should be organized in a way that the peak metabolic heat production will not coincide with the highest point in environmental temperature.

## Water Supply

Water is one of the limiting factors in broiler production. It is an essential nutrient that must be taken into consideration if expected productivity is to be achieved. Factors that are of importance in drinking water for chickens include quantity, quality, temperature, salinity, and microbial load. Water supply to the broiler houses must be clean and constant. Broiler chickens consume more water during hot period than in cold climate (Manning et al. 2007; Bruno et al. 2011). Its restriction was reported to raise heterophil-lymphocyte ratio, a major indicator of stress in broiler chickens. Availability of drinkable water during hot spells must be ensured. Water restriction caused reduced weight of lymphoid organs in broiler chickens (Mustafa et al. 2010), which may negatively impact the innate immunity of the birds. In South-Eastern Nigeria located in the rain forest zone, water restriction up to 1.2 liters per day was found to have deleterious effects of the hematological parameters and caused increased activity of liver enzyme which is an indicator of cellular necrosis in broiler chickens (Iheukwumere and Herbert 2003). Water restriction had negative effects on the renal functioning, digestion, immunity, and other vital body systems. Birds subjected to water restriction had an altered behavior, becoming aggressive and irritated. Therefore, water restriction irrespective of the magnitude must not be allowed in broiler production.

Water temperature is another important factor that must be put into right perspective. Warm water is nauseating and not readily acceptable to chickens.

**Table 2** Rectal temperature and respiratory rate in broilers offered water of two different temperatures

Parameter	Water temperature		Standard error of means (sem)
	Ordinary	Low	
Water temperature (°C)	30.0	16.0	0.09
RT at 08.00 h (°C)	41.7 <sup>a</sup>	41.5 <sup>b</sup>	0.03
RT at 16.00 h (°C)	42.5 <sup>a</sup>	42.1 <sup>b</sup>	0.04
RR at 08.00 h (breaths/min)	54.0 <sup>a</sup>	46.7 <sup>b</sup>	1.13
RR at 16.00 h (breaths/min)	85.2 <sup>a</sup>	62.6 <sup>b</sup>	2.11

Abioja MO (Unpublished data)

<sup>a</sup>, <sup>b</sup>Means with differing superscripts within a row were significantly different ( $P < 0.05$ )

Chilled water is preferred to water at ambient temperature. Offering water at low temperature may reduce heat load and respiratory rate in broiler chickens (Table 2). This has been proved to help combat HS in broilers (Abioja et al. 2011, 2013). Practical activity in cooling water may involve having water reservoirs placed under shade to disallow overheating by direct sunlight during hot periods. Many poultry managers in all over Africa have been supplying their birds with water cooled with ice cubes during the dry season. The enhanced respiratory rate during HS is critical for body temperature maintenance because of its resultant evaporative cooling.

Specific consequences of the acid-base perturbations have indeed been identified. Electrolytes lost can be replenished with sodium (Na), potassium (K), calcium (Ca), magnesium (Mg), chlorine (Cl), bicarbonate ( $\text{HCO}_3$ ), and sulfate ( $\text{SO}_4$ ) salts in water (Ahmad and Sarwar 2006). The addition of the electrolytes to the drinking water not only alters the bird's osmotic balance by replenishing those depleted during HS but also stimulates water consumption and influences water balance. Some African native chickens had been found to have tolerance for water shortage. Chikumba and Chimoyo (2014) reported that Southern African naked neck chickens was found to performed better than Ovambo chickens under conditions of water restriction and would be ideal to raise for meat and egg production in locations where water shortages are a major challenge.

## Stocking Density

Each bird in the flock emits radiant heat to the environment. Low stocking density reduces the number of birds producing heat and the amount of heat that must be removed from the house to maintain temperature. Recommended stocking density appropriate for different housing type should be strictly adhered to. Assuming each bird weigh 2 kg at slaughter, for controlled environment, the maximum stocking density at slaughter should be 30 kg/m<sup>2</sup>; controlled environment during hot period, 24–26 kg/m<sup>2</sup>; open-sided house, 20–22 kg/m<sup>2</sup>; and open-sided house during hot period, 16–18 kg/m<sup>2</sup>. Abudabos et al. (2013) reported that increasing the stocking

density rate from 28 to 40 kg of body weight/m<sup>2</sup> had evident negative effects on the growth performance of broiler chicken. Higher stocking density does jeopardize the well-being of the chickens.

## Epigenetic Adaptation to Thermal Assaults

Chickens are precocial birds having the development of body functions starting early during the embryonic phase (Nichelmann and Tzschentke 2002). Thermoregulatory mechanisms start during prenatal stage but not fully matured as at pre- and peri-hatch periods (Tzschentke and Basta 2002; Tzschentke et al. 2004). At this point, exposure to a level of stress can trigger an imprinting in chickens. Acute changes in the environmental conditions especially thermal environments induce as a rule, first uncoordinated and immediately nonadaptive reactions. Later, the uncoordinated (immediately) nonadaptive reactions change into coordinated (adaptive) reactions (Tzschentke 2007). Stress is usually avoided because of its perceived repercussions on living tissues. However, evidences are emanating from various research works that exposure of broiler chicks to mild stress at early age help in acquiring thermotolerance at latter age. This was first reported in rats by Levine (1962). The author discovered that mild stress at early age affects the adrenocortical functioning during adulthood.

It was later confirmed in broiler chickens (Yahav and Plavnik 1999; Zulkifli et al. 2000; Liew et al. 2003). From this assertion, there are two strategies that have been explored: thermal conditioning (TC) and early feed restriction (EFR). TC involves exposing chicks at early age post-hatch to elevated ambient temperature (Arjona et al. 1990; Yahav and Hurwitz 1996; Yahav and McMurtry 2001) within the first 6 days while EFR subjected the chicks to varying degrees of hunger during the same period (Zulkifli et al. 1994). TC has been demonstrated to be effective as a tool for thermotolerance acquisition in poultry but its application is not practicable in the traditional open-sided poultry houses common in most tropical and developing countries. The cost of heating poultry house to a desired temperature is high. Besides, the technicality associated with thermal conditioning such as length and degree of heat exposure may not be easily mastered by the local farmers. This leaves the only option for thermotolerance acquisition in the developing and underdeveloped world to application of early feed restriction.

Sublethal stress imposed by feed withdrawal in the early age post-hatch on broiler chicks has been noted to confer inherent capability in the birds to cope with stress in latter age (Liew et al. 2003). Abioja et al. (2014) have found that applying EFR to broiler chicks of d5 post-hatch for 24 h may help reduce hyperthermia that is common during heat spell in pen at market age. It is not known whether the response will be the same during transportation as in the acute heat spell. Improved thermotolerance in broiler chickens at market age will help against losses that do occur during transportation. Adopting feed restriction during early period of life in broiler chickens as a means of improving thermotolerance in broiler chickens is easier for farmers than adjusting pen temperature. Induced thermotolerance is generally

referred to as the state at which an organism is transiently more resistant to killing by heat due to a short pretreatment at moderately elevated ambient temperatures. This usually takes place before the brain is fully matured for thermoregulation. During ontogeny in chicken, embryo undergoes a transition from poiklothermy to homeothermy, which is completed, at the early post-hatching. Full-blown homeothermy starts at approximately 10 days post-hatch. Early age thermal conditioning by exposing young chicks to 40 °C for 24 h reduces body temperature and improves long-term broiler resistance to HS without negative effects on growth and feed conversion ratio.

Zulkifli et al. (2000) reported that acute HS resulted in increase in heterophil/lymphocyte ratio for all feed-restricted groups and the ad libitum group. But broilers restricted from 60% of daily feed requirement on day 4, 5, and 6 had the least heterophil/lymphocyte ratio. The authors concluded it appeared 60% feed restriction is beneficial in improving growth and survivability of female broiler chickens exposed to HS later in life. The authors restricted the feed by percentage on three consecutive days (day 4, 5, and 6). Exact feed intake of the birds may not be ascertained: feed intake depends on strain, genotype, environmental condition in the pen, body weight, etc. Farmer may have problem calculating the feed intake. Besides, percentage feed restriction may not give the exact day the EFR is most effective. Therefore it is important to determine exact day of life the chicks should be subjected to early feed restriction by farmer which ensures best acquisition of thermotolerance.

## Use of Honey and Other Natural Phytochemicals

The age-long conventional use of antistress antioxidant formula containing a mixture of vitamins and minerals to help broiler chickens cope during heat spell in rearing has proved to be effective. However, the use of phytochemicals that possess or are suspected to possess efficacious antioxidant properties in the management of HS in poultry production is becoming more popular (Abioja et al. 2012). Efficacy of honey and some other naturally occurring materials from plants such as coconut water, olive leaf extract, and propolis during stressful conditions in chickens had been reported in literatures. Honey has recently been reputed as a possible natural source of antioxidant in broiler chickens (Abioja et al. 2012; Osakwe and Igwe 2015; Oke et al. 2016) with some positive results because of its phenolic and flavonoid compounds content and various phytochemicals that possess antioxidant properties. It has been used during acute heat and transportation stress conditions. Honey is effective because some of its components are substances known to have physiological actions in the body systems of animals. Diluted drinking water of concentration 20 ml honey dissolved in a liter drinking water had positive effect on respiratory and heart rates, calcium metabolism, bone formation, and some internal organs in heat stressed broiler chickens. Honey in drinking water could be of help in improving the welfare of broiler chickens during stress episode by increasing the packed cell volume, red blood cell count, and hemoglobin concentration according to Abioja

et al. (2019). It helps in protecting gastrointestinal tract, liver, kidney, pancreas, eye, plasma, red blood cells, and reproductive organs against oxidative stress in rats (Zaid et al. 2011; Erejuwa et al. 2012).

The presence of phenolic compounds and flavonoids in honey had been primarily implicated as the reason for its antioxidant activity. Phenolic compounds are good in free radical scavenging, hydrogen donation, singlet oxygen quenching, and metal ion chelation. Phenolics and flavonoids do help in correction of the redox perturbations in the body by counteracting the damage caused by oxidants such as oxygen, hydroxide, superoxide, and/or lipid peroxy radicals. Exogenous nonenzymatic antioxidants in honey synergistically support the endogenous antioxidant enzymes, such as superoxide dismutase (SOD), catalase (CAT), and glutathione peroxidase (GPX), to eradicate reactive oxygen species. Honey has various antioxidant constituents that act together for the same goal but at different cellular and subcellular levels (Erejuwa et al. 2012; Oryan et al. 2016; Kamaruzzaman et al. 2019).

It contains no fat and cholesterol contents. However, the use of honey must be with caution. It was reported that there were infiltrations of fat cells in the liver tissue of albino rats fed with honey over a long period. This may result in nonalcoholic fatty liver disease or in other unpleasant conditions harmful to health if not well managed. It has been discovered that long-term administration of honey caused deformation and atrophy of specific reproductive apparatus in laying chickens. Other authors had earlier stated that chronic consumption of unprocessed Nigerian honey resulted in decreased bile flow, increased bile cholesterol, and decreased plasma cholesterol in albino rats. The fear that more cholesterol molecules especially much dreaded low-density lipoproteins may be deposited in the eggs of chickens offered honey is pervading the air. Besides, vitamin A content is important in human nutrition. Improvement in vitamin A content of eggs will go a long way in correcting its deficiency and contribute to the welfare of consumers. Millions of preschool-aged children in developing countries are suffering from vitamin A deficiency, which may lead to blindness (Underwood 1998). The deficiency of vitamin A is a public health issue that needs attention. Fortification of eggs for the children will be a welcome idea, should honey help in achieving this. By-products of honey such as honey slum gum (Babarinde et al. 2011), propolis (Chen et al. 2009), and bee pollen (Wang et al. 2005; Haščík et al. 2012) had been used in broiler production and found to be effective.

Honey is good but must be used with caution, especially in its application in poultry production. In literature, it has been reported that there were infiltrations of fat cells in the liver tissue of rats which was dosage-dependent (Avwioro et al. 2012), decreased bile flow, increased bile cholesterol, and decreased plasma cholesterol (Alagwu et al. 2009) in Albino rats and hypertrophy of follicle, giving it a deformed shape instead of the usual round shape in laying chickens (Abioja and Adekunle 2018). The authors concluded that chronic consumption of honey may increase the risk of hepatic damage.

Naturally occurring solution found inside the fleshy eatable part of coconut called coconut water could also be used as antistress in broiler chickens during heat spells. It contains a lot of bioactive metabolites which have not been explored (Reddy and

Lakshmi 2014). Preliminary studies (Abioja et al. 2015) with diluted coconut water in drinking water as a viable candidate in lowering body temperature in heat and transportation stressed broiler chickens gave a promising results. Saat et al. (2002) stated that coconut water has been used in humans after physical exercise or long journey as an ideal rehydrating and refreshing drink. Its sugar content and mineral composition (electrolytes) have been identified as reason for the usefulness. Coconut water stimulates higher water consumption, which ensures availability of enough water in the body to facilitate evaporative cooling (panting) under hot environmental conditions. Chickens ingest more water under HS conditions. Prades et al. (2012a, b) reviewed the uses, composition, properties, preservation, and processing of coconut water. Major constraint in the adoption of coconut water as antistress in broiler production is in quantity that would be required for a large-scale commercial broiler industry. More research works are necessary to ascertain the appropriate concentration of diluted coconut water for the chickens. However, it can be used easily in small scale, backyard, and family poultry production. Other materials that could be used in ameliorating the negative effects of HS are raffia palm wine, olive leaf extract, and orange peel extract.

## **Breeding for Thermotolerant Strains in Africa**

Broiler chickens reared in the tropics were developed in the cooler regions of the world and introduced into the tropics. They often respond differently under the new environment, mostly growing at lower rate than in their home environment. Thus optimal poultry production in the hot regions therefore requires an adequate and appropriate management system that can reduce the effects of HS to the minimum. Olori (2008) in a review stated that to develop broiler chickens for Africa, an understanding of the factors affecting poultry production such as the climate, production systems, and available feed resources in Africa is required. One of the major constraints in broiler breeding is the fact that productivity traits are negatively correlated with thermotolerance. The available major genes (naked-neck, frizzle-feather, and dwarfism) in locally adapted breeds of chickens all over Africa must be explored. FUNAAB-alpha broiler lines were developed by Professor Olufunmilayo Adebambo and her team from several crosses and selection activities among flocks of Nigerian local chickens. The newly developed chicken lines had just been registered and tested in different agro-ecological zones of the Nigeria and parts of West African coast.

A recent report on the on-station performance evaluation of improved tropically adapted chicken breeds for smallholder poultry production systems in Nigeria was given by Bamidele et al. (2019). The authors in the study identified FUNAAB Alpha and Noiler as being more suitable for dual-purpose functions (egg and meat), while Sasso and Kuroiler (meat) and Shika-Brown (egg) were observed to be better suited for single purpose functions. Chickens bred taken into consideration the climate of African land should be given preference as the pangs of climate change is envisaged. Breeds like FUNAAB-alpha, Kuroiler, Noiler, Sasso, and Shika-brown chickens are now becoming popular in the hot regions of Africa.



---

## Others Adaptation Options

Organization of enlightenment programs, workshops, and trainings for the broiler producers and stakeholders on adaptation of broiler chickens to climate change from time to time by governmental agencies is necessary in Africa. Awareness and advocacy about climate change should be extended to the young people and other categories of people. Sustainable Development Goals should involve younger generations of African populace in schools where they can be furnished with adequate and up-to-date information about climate change. Indigenous technical know-hows of the African peoples, in forms of herbs, extracts, and other phytochemicals should be explored in keeping broiler chickens adapted to impending global warming.

---

## Conclusion

As the evidences of climate change are becoming more pronounced over Africa, various adaptation options available for broiler production in literatures include building housing systems that ensure climate amelioration for the birds, manipulations of feed and feeding systems, supplying adequate water of good quality, ensuring adequate stocking density, use of natural phytochemicals that ensure balanced oxidative status in the body system, and breeding for thermotolerant strains in Africa. Enlightenment programs should be organized for poultry farmers by governmental and nongovernmental agencies on the climate change mitigation, adaptation, and resilience strategies in order to improve livelihood of the people in a sustainable manner.

---

## References

- Abioja MO (2010) Temperature-humidity effects on egg fertility and evaluation of vitamin C and cold water on broiler growth in hot season. A Ph.D. thesis submitted to Department of Animal Physiology, University of Agriculture, Abeokuta, 157pp
- Abioja MO, Adekunle MO (2018) Climate change: depression in Egg production in chickens during the hot season with long term honey administration. In: Leal Filho W (ed) Handbook of climate change resilience. Springer International Publishing AG, [https://doi.org/10.1007/978-3-319-71025-9\\_15-1](https://doi.org/10.1007/978-3-319-71025-9_15-1)
- Abioja MO, Abiona JA, Sodipe OG, Adeleye OO, Akibo TE, Daramola JO, Oke OE, Williams TJ, Oguntuase OM, Oladapo OI, Okanlawon OR, Mudasiru AO, Siyanbola AY, Ogunduyi BO, Soyiga BM, James IJ, Osinowo OA (2015) Effect of coconut water on rectal temperature and blood glucose in broilers subjected to acute heat and transportation stress. *Nig J Anim Sci* 17 (2):141–147
- Abioja MO, Akinjute OF, Balogun SI, Oguntimehin MS, Oluwasola TO (2019) Effect of honey on haematology, plasma biochemistry and liver enzymes in broiler chickens administered dietary corticosterone. *Stress Physiol Biochem* 15(3):5–13
- Abioja MO, Ogundimu KB, Akibo TE, Odotola KE, Ajiboye OO, Abiona JA, Williams TJ, Oke OE, Osinowo OA (2012) Growth, mineral deposition and physiological responses of broiler chickens offered honey in drinking water during hot-dry season. *Int J Zool* 4:1–6

- Abioja MO, Osinowo OA, Smith OF, Eruvbetine D (2013) Physiological and haematological responses of broiler chickens offered cold water and vitamin C during hot-dry season. *Nig J Anim Prod* 40(1):24–36
- Abioja MO, Osinowo OA, Smith OF, Eruvbetine D, Abiona JA (2011) Evaluation of cold water and vitamin C on broiler growth during hot-dry season in South-Western Nigeria. *Archiv de Zoot* 60 (232):1095–1103
- Abioja MO, Sodipe OG, Abiona JA, Oladipo KA, Kasali OD, Akerele Z, Ola A, Oke H, Ogundele O, Osinowo OA (2014) Thermotolerance acquisition in broiler chickens through early feed restriction: response to acute heat stress. *Pertanika J Trop Agric Sci* 37(3): 311–319
- Abudabos AM, Samara EM, Hussein EOS, Al-Ghadi MQ, Al-Atiyat RM (2013) Impacts of stocking density on the performance and welfare of broiler chickens. *Italian J Anim Sci* 12:683–692
- ACMAD (2017) The state of climate in Africa. African Center for Meteorological Application for Development. <https://www.acmad.net/new/sites/default/files/The-State-of-Climate-in-Africa-2017-Report-March-2018-ACMAD.pdf>. Accessed 11 Mar 2020
- Ahmad T, Sarwar M (2006) Dietary electrolyte balance: implications in heat stressed broilers. *Worlds Poult Sci J* 62:638–653
- Alagwu E, Nneli RO, Okwari OO, Osim EE (2009) Bile secretion in albino rat following chronic honey intake. *Nig J Physiol Sci* 24:203–206
- Alemayehu A, Woldeamlak B (2017) Smallholder farmers' coping and adaptation strategies to climate change and variability in the central highlands of Ethiopia. *Local Environ* 22(7):825–839. <https://doi.org/10.1080/13549839.2017.1290058>
- Al-Saffar AA, Rose SP (2002) Ambient temperature and the egg laying characteristics of laying fowl. *Worlds Poult Sci J* 58(3):317–332
- Altan O, Altan A, Oguz I, Pabuccuoglu A, Konyalioglu S (2000) Effects of heat stress on growth, some blood variables and lipid oxidation in broilers exposed to high temperature at an early age. *Br Poult Sci* 41(4):489–493
- Arjona AA, Denbow DM, Weaver WD Jr (1990) Neonatally-induced thermotolerance: physiological responses. *Comp Biochem Physiol* 95A:393–399
- Attia YA, Hassan RA, Tag El-Din AE, Abou-Shehema BM (2011) Effect of ascorbic acid or increasing metabolizable energy level with or without supplementation of some essential amino acids on productive and physiological traits of slow-growing chicks exposed to chronic heat stress. *J Anim Physiol Anim Nutr* 95:744–755
- Avwioro GO, Onyije FM, Atoni AD, Nduku A (2012) Non-alcoholic fatty liver disease following administration of unprocessed Nigerian honey. *Adv Biol Res* 6:141–145
- Awojobi HA, Oluwole BO, Adekunmisi AA, Buraimon RA (2009) Performance of finisher broilers fed wet mash with or without drinking water during wet season in the tropics. *Int J Poult Sci* 8 (6):592–594
- Ayo JO, Obidi JA, Rekwot PI (2011) Effects of heat stress on the well-being, fertility and hatchability of chickens in the northern Guinea savannah zone of Nigeria: a review. *ISRN Vet Sci* 1–10. <https://doi.org/10.5402/2011/838606>
- Babarinde SA, Oladunjoye IO, Ojebiyi OO, Oyedeji SA (2011) Inclusion of honey bee slum gum in broiler chicken feed. *Int J Agric Biol* 13(5):781–785
- Bamidele O, Sonaiya EB, Adebambo OA, Dessie T (2019) On-station performance evaluation of improved tropically adapted chicken breeds for smallholder poultry production systems in Nigeria. *Trop Anim Health Prod*. <https://doi.org/10.1007/s11250-019-02158-9>
- Borges SA, Fischer da Silva AV, Ariki J, Hooge DM, Cummings KR (2003) Dietary electrolyte balance for broiler chickens under moderately high ambient temperatures and relative humidities. *Poult Sci* 82:301–308
- Bruno LDG, Maiorka A, Macari M, Furlan RL, Givisiez PEN (2011) Water intake behaviour of broiler chickens exposed to heat stress and drinking from bell or and nipple drinkers. *Brazilian J Poult Sci* 13(2):147–152
- Calefi AS, Quinteiro-Filho WM, Ferreira AJP, Palermo-Neto J (2017) Neuroimmunomodulation and heat stress in poultry. *Worlds Poult Sci J* 73:493–504

- Chen YJ, Huang AC, Chang HH, Liao HF, Jiang CM, Lai LY, Chan JT, Chen YY, Chiang J (2009) Caffeic acid phenethyl ester, an antioxidant from propolis, protects peripheral blood mononuclear cells of competitive cyclists against hyperthermal stress. *J Food Sci* 74(6):H162–H167
- Chikumba N, Chimonyo M (2014) Effects of water restriction on the growth performance, carcass characteristics and organ weights of naked neck and Ovambo chickens of southern Africa. *Asian-Austral J Anim Sci* 27(7):974–980
- Dei H, Bumbie GZ (2011) Effect of wet feeding on growth performance of broiler chickens in a hot climate. *Br Poult Sci* 52(1):82–85
- Erejuwa OO, Sulaiman SA, Ab Wahab MS (2012) Honey: a novel antioxidant. *Molecules* 17(4):4400–4423
- FAO (2006) Food and agriculture organization of United Nations. Livestock's long shadow: environmental issues and options. <http://www.fao.org/3/a0701e/a0701e.pdf>. Accessed 11 Mar 2020
- FAO (2020) Gateway to poultry production and products. <http://www.fao.org/poultry-production-products/production/poultry-species/chickens/en/>. Accessed 11 Mar 2020
- Farghly MFA, Galal AE, Ahmad EAM (2019) Using wet feed in feeding Japanese quail under summer conditions. *Egyptian Poult Sci J* 39(2):391–403
- Haščík P, Elimam I, Garlík J, Kacániová M, Cubon J, Bobko M, Abdulla H (2012) Impact of beer pollen as feed supplements on the body weight of broiler *Ross 308*. *Afr J Biotech* 11(89):15596–15599
- Hummel D (2015) Climate change, land degradation and migration in Mali and Senegal- some policy implications. *Migration and Devt* 5(2):211–233
- Iheukwumere FC, Herbert U (2003) Physiological responses of broiler chickens to quantitative water restrictions: haematology and serum biochemistry. *Int J Poult Sci* 2(2):117–119
- IPCC (2007) Intergovernmental panel on climate change: AR4-the intergovernmental panel on climate change 4th assessment report. Jackson Institute, University College, London
- Kamaruzzaman MA, Chin KY, Ramli ESM (2019) A review of potential beneficial effects of honey on bone health. *Evid Based Complementary Altern Med* 1–10. <https://doi.org/10.1155/2019/8543618>
- Karaca AG, Parker HM, Yeatman JB, McDaniel CD (2002) The effects of heat stress and sperm quality classification on broiler breeder male fertility and semen ion concentrations. *Br Poult Sci* 43(4):621–628
- Lara LJ, Rostagno MH (2013) Impact of heat stress on poultry production. *Animals* 3:356–369
- Levine S (1962) Plasma-free corticosteroid response to electric shock in rats stimulated in infancy. *Science* 135:795–796
- Liew PK, Zulkifli I, Hair-Bejo M, Omar AR, Israf DA (2003) Effects of early age feed restriction and heat conditioning on heat shock protein 70 expression, resistance to infectious bursal disease and growth in male broiler chickens subjected to heat stress. *Poult Sci* 82:1879–1885
- Manning L, Chadd SA, Baines RN (2007) Water consumption in broiler chicken: a welfare indicator. *Worlds Poult Sci J* 63:63–71
- Mitchell MA, Sandercock DA, Macleod MG, Hunter RR (2005) Thermoregulatory and metabolic heat production responses during acute heat stress in genetically improved broiler chickens. Proceedings of the international poultry scientific forum. Southern Poultry Science Society, Atlanta, p 110
- Mustafa YS, Sulehria AQK, Muneer MA, Munir R (2010) Effect of water restriction on the lymphoid organs and production of broilers. *Biologia* 56(1&2):63–68
- Ngaira JKW (2007) Impact of climate change on agriculture in Africa by 2030. *Scient Res Essays* 2(7):238–243
- Niang I, Ruppel OC, Abdrabo MA, Essel A, Lennard C, Padgham J, Urquhart P (2014) In: Barros VR, Field CB, Dokken DJ, Mastrandrea MD, Mach KJ, Bilir TE, Chatterjee M, Ebi KL, Estrada YO, Genova RC, Girma B, Kissel ES, Levy AN, MacCracken S, Mastrandrea PR, White LL (eds) Climate change: Impacts, adaptation and vulnerability. Part B: regional aspects. Contribution of Working Group II to the Fifth Assessment Report of the Intergovernmental Panel on Climate Change. Cambridge University Press, Cambridge, United Kingdom and New York, pp 1199–1265

- Nichelmann M, Tzschentke B (2002) Ontogeny of thermo-regulation in precocial birds. *Comp Biochem Physiol* 131(4):751–763
- Oke OE, Sorungbe FO, Abioja MO, Oyetunji O, Onabajo AO (2016) Effect of different levels of honey on physiological, growth and carcass traits of broiler chickens during dry season. *Acta Agric Slov* 108:45–53
- Olori VE (2008) Breeding broilers for production systems in Africa. *Nig Poult Sci J* 5(4):173–180
- Oryan A, Alemzadeh E, Moshiri A (2016) Biological properties and therapeutic activities of honey in wound healing: a narrative review and meta-analysis. *J Tissue Viability* 25(2):98–118
- Osakwe I, Igwe R (2015) Physiological responses of laying birds fed honey and vitamin C in drinking water. In: A paper presented at conference on international research on food security, natural resource management and rural development, pp 1–6
- Prades A, Dornier M, Diop N, Pain JP (2012a) Coconut water uses, composition and properties: a review. *Fruits* 67:87–107
- Prades A, Dornier M, Diop N, Pain JP (2012b) Coconut water preservation and processing: a review. *Fruits* 67:157–171
- Reddy EP, Lakshmi TM (2014) Coconut water- properties, uses, nutritional benefits in health and wealth and in health and disease: a review. *J Curr Trends Clin Med Lab Biochem* 2(2):6–18
- Renaudeau D, Collin A, Yahav S, De Basilio V, Gourdine JL, Collier RJ (2012) Adaptation to hot climate and strategies to alleviate heat stress in livestock production. *Animal* 6:707–728
- Rozenboim I, Tako E, Gal-Garber O, Proudman JA, Uni Z (2007) The effect of heat stress on ovarian function of laying hens. *Poult Sci* 86(8):1760–1765
- Saat M, Singh R, Gamini Sirisinghe R, Nawawi M (2002) Rehydration after exercise with fresh young coconut water, carbohydrate electrolyte beverage and plain water. *J Physiol Anthropol Appl Human Sci* 21:93–104
- Santos RR, Awati A, Roubos-van den Hil PJ, Tersteeg-Zijderveld MH, Koolmees PA, Fink-Gremmels J (2015) Quantitative histo-metric analysis of heat-stress-related damage in the small intestines of broiler chickens. *Avian Pathol* 44(1):19–22
- Shields S, Greger M (2013) Animal welfare and food safety aspects of confining broiler chickens to cages. *Animals* 3:386–400
- Simsek UG, Erisir M, Ciftci M, Tatli Seven P (2014) Effects of cage and flooring housing systems on fattening performance, oxidative stress and carcass defects in broiler chicken. *Kafkas Üniversitesi Veteriner Fakültesi Dergisi* 20(5):727–733
- Syafwan S, Kwakkel RP, Verstegen MWA (2011) Heat stress and feeding strategies in meat-type chickens. *Worlds Poult Sci J* 67(4):653–674
- Tiruneh S, Tegene F (2018) Impacts of climate change on livestock production and productivity and different adaptation strategies in Ethiopia. *J Applied Adv Res* 3(3):52–58
- Tzschentke B (2007) Attainment of thermoregulation as affected by environmental factors. *Poult Sci* 86:1025–1036
- Tzschentke B, Basta D (2002) Early development of neuronal hypothalamic thermosensitivity in birds: influence of epigenetic temperature adaptation. *Comp Biochem Physiol* 131A:825–832
- Tzschentke B, Basta D, Janke O, Maier I (2004) Characteristics of early development of body functions and epigenetic adaptation to the environment in poultry: focused on development of central nervous mechanisms. *Avian Poult Biol Rev* 15:107–118
- Underwood BA (1998) Perspectives from micronutrient malnutrition eradication programs. *B World Health Organ* 76: 34–37
- Wang J, Jin GM, Zheng YM, Li SH, Wang H (2005) Effect of bee pollen on development of immune organ of animal. *Zhongguo Zhong Yao Za Zhi* 30:1532–1536
- Yahav S (2000) Domestic fowl: strategies to confront environmental conditions. *Avian Poult Biol Rev* 11:81–95
- Yahav S, Hurwitz S (1996) Induction of thermotolerance in male broiler chickens by temperature conditioning at an early age. *Poult Sci* 75:402–406
- Yahav S, McMurtry JP (2001) Thermotolerance acquisition in broiler chickens by temperature conditioning early in life – the effect of timing and ambient temperature. *Poult Sci* 80:1662–1666

- Yahav S, Plavnik I (1999) Effect of early-age thermal conditioning and food restriction on performance and thermotolerance of male broiler chickens. *Br Poult Sci* 40:120–126
- Zaid SS, Sulaiman SA, Sirajudeen KN, Othman NH (2011) The effects of Tualang honey on female reproductive organs, tibia bone and hormonal profile in ovariectomised rats-animal model for menopause. *BMC Complementary Altern Med* 10:82–90
- Zulkifli I, Che Norma MT, Israf DA, Omar AR (2000) The effect of early age feed restriction on subsequent response to high environmental temperatures in female broiler chickens. *Poult Sci* 79:1401–1407
- Zulkifli I, Dunnington EA, Gross WB, Siegel PB (1994) Inhibition of adrenal steroidogenesis, food restriction and acclimation to high ambient temperatures in chickens. *Br Poult Sci* 35:417–426

**Open Access** This chapter is licensed under the terms of the Creative Commons Attribution 4.0 International License (<http://creativecommons.org/licenses/by/4.0/>), which permits use, sharing, adaptation, distribution and reproduction in any medium or format, as long as you give appropriate credit to the original author(s) and the source, provide a link to the Creative Commons license and indicate if changes were made.

The images or other third party material in this chapter are included in the chapter's Creative Commons license, unless indicated otherwise in a credit line to the material. If material is not included in the chapter's Creative Commons license and your intended use is not permitted by statutory regulation or exceeds the permitted use, you will need to obtain permission directly from the copyright holder.





# Climate Change Adaptation Options in Farming Communities of Selected Nigerian Ecological Zones

# 17

Ayansina Ayanlade, Isaac Ayo Oluwatimilehin, Adeola A. Oladimeji, Godwin Atai, and Damilola T. Agbalajobi

## Contents

Introduction .....	298
Climate Change Assessment in Selected Ecological Zones in Nigeria .....	299
Annual Variability in Rainfall and Minimum and Maximum Temperature .....	301
Relationship Between Climate and Crop Yield .....	306
Farmer's Adaptive Strategies .....	308
Conclusion .....	309
References .....	310

## Abstract

This chapter examines the impacts of climate change on three tropical crops and assesses the climate change adaptation options adopted by rural farmers in the region. The study was conducted among farming communities settled in three major ecological zones in Nigeria. Over 37 years of data on rainfall and temperature were analyzed to examine climate change impacts on three major crops: rice, maize, and cassava. Farmers' adaptive capacity was assessed with a survey. Climatic data, crop yields, and survey data were analyzed using both descriptive and inferential statistics. The relation between rainfall/temperature and crop

This chapter was previously published non-open access with exclusive rights reserved by the Publisher. It has been changed retrospectively to open access under a CC BY 4.0 license and the copyright holder is "The Author(s)". For further details, please see the license information at the end of the chapter.

A. Ayanlade (✉) · I. A. Oluwatimilehin · G. Atai  
Department of Geography, Obafemi Awolowo University, Ile-Ife, Nigeria  
e-mail: [ayaanlade@oauife.edu.ng](mailto:ayaanlade@oauife.edu.ng); [sinaayanlade@yahoo.co.uk](mailto:sinaayanlade@yahoo.co.uk)

A. A. Oladimeji  
Department of Microbiology, University of Ibadan, Ibadan, Nigeria

D. T. Agbalajobi  
Department of Political Science, Obafemi Awolowo University, Ile-Ife, Nigeria

yields was examined using the Pearson correlation coefficient. Results show a high variation in the annual rainfall and temperature during the study period. The major findings from this research is that crops in different ecological zones respond differently to climate variation. The result revealed that there is a very strong relationship between precipitation and the yield of rice and cassava at  $p < 0.05$  level of significance. The results further showed low level of adaption among the rural farmers. The study concludes that rainfall and temperature variability has a significant impact on crop yield in the study area, but that the adaptive capacity of most farmers to these impacts is low. There is a need for enhancing the adaptation options available to farmers in the region, which should be the focus of government policies.

---

**Keywords**

Adaptation · Climate change · Crop yield · Impacts · Nigeria

---

**Introduction**

Given their impacts on both natural and human systems, climate variability and climate change have become topical issues in recent research. As the changing nature of weather and climate directly relates to crop yields, climate change impacts on the agricultural sector and food systems have been the focus of a growing number of works, including research in many African countries (Adenle et al. 2017; Morton 2017; Serdeczny et al. 2017; Molua 2020). Such studies have reported that rainfall and minimum and maximum temperatures are the most important climatic elements for agricultural production. The scenario over the years is that these climate parameters, especially rainfall patterns, have varied, with some high confidence of change in their patterns in recent years, as perceived through indigenous knowledge of people globally (Adejuwon 2005; Ayanlade 2009; Sowunmi and Akintola 2010; Moylan 2012; Adamgbe and Ujoh 2013; Pablo and Antonio 2015; Ayanlade et al. 2017). The multi-hazard events climate change occasions comprising of windstorms, wildfire, rainstorms, droughts, and dust storms which maybe become more frequent with increased severity in the nearest future. There are several pieces of evidence in the literature that land use and land cover change (Ayanlade 2017; Fourcade et al. 2019), sea-level rise (Agboola and Ayanlade 2016; Varela et al. 2019), and changes in onset will pose significant long-term challenges. There have been changes that can be identified by alteration in the mean or variability of climate properties and that have persisted for an extended period. Consequently, climate change will pose imperative short-term and long-term bottlenecks to agricultural production, particularly for rural farmers who depend on rainfall for cultivation (IPCC 2007; Heltberg et al. 2009; Ayanlade et al. 2018b; Ayanlade and Ojebisi 2020).

Agriculture is vulnerable to climate change as crops are sensitive to rising temperatures and changing rainfall patterns. Rising temperatures and erratic rainfalls threaten food crop production, thus exacerbating food insecurity and poverty (Sanchez 2000;

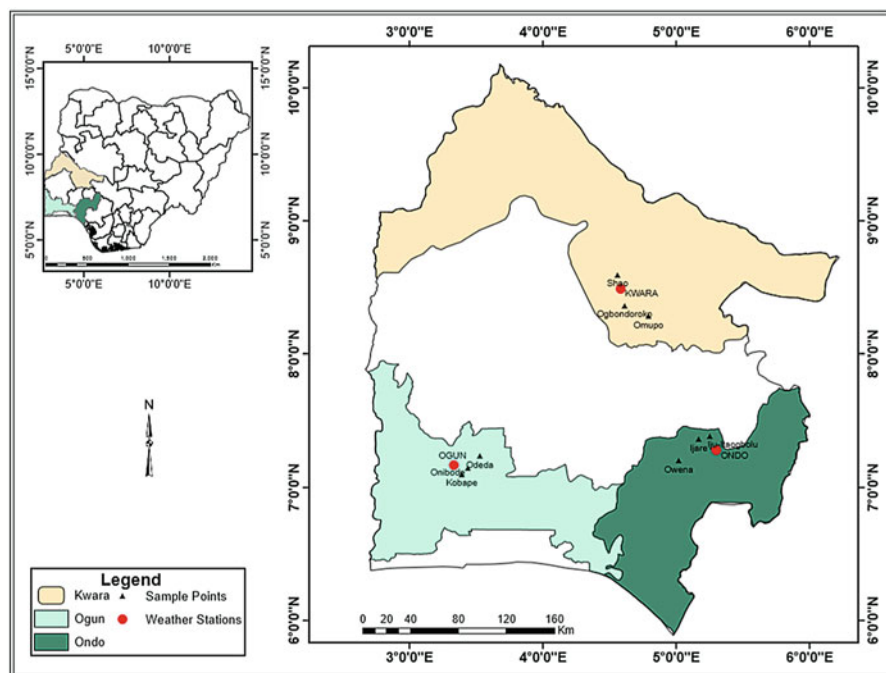
Oluoko-Odingo 2011; Seaman et al. 2014). The impacts of climate change on agriculture are likely to intensify in the future as climate models have predicted increasing temperature and more erratic rainfall with the potential increase in the intensity and frequency of extreme weather events (Wright et al. 2014; Ayanlade et al. 2018a; Hein et al. 2019). For example, some studies have suggested that climate change will reduce the yield of crops like maize, rice, and cassava by 15–25%, partly because climate change will alter the incidence and severity of pest and disease outbreaks, indirectly affecting crop production and yield (Harvey et al. 2018). Even though climate change portends serious dangers to agriculture, current studies on climate change impacts on the agricultural systems of Nigeria suffer from several gaps. First, previous studies have mostly focused on crops like yam, coffee, cocoa, sorghum, etc. (Ayanlade 2009; Ayanlade et al. 2009; Ajetomobi 2016). Other studies on the topic have used short-term data, although long-term data is more accurate in delineating climate change effects on agricultural practices (Adejuwon 2005, 2012). Thus, previous research on this topic has treated Nigeria as a single ecological zone. To fill these gaps, the present study focuses on climate change impacts on three crops that have not previously received attention (i.e., rice, maize, and cassava) and using data from three (3) different states in Nigeria, falling within three different ecological zones: Ondo (Rainforest), Ogun (Freshwater), and Kwara state (Guinea savanna). This spread will importantly give room for spatiotemporal comparison. More so, this study involves the indigenous knowledge of climate change, effects, impacts, and adaptation practices among the rural farmers. Rural farming is very important in this part of the world for the provision of food and productive employment for many people.

---

## Climate Change Assessment in Selected Ecological Zones in Nigeria

Research as conducted in three different sites (Fig. 1), representing three different ecological zones: Ondo (rainforest located within latitude 7°10'N, 7°15'N and longitudes 5°5'E and 5°83'E); Ogun (freshwater, located between on latitude 6°12'N and 7°47'N and longitude 3°0'E and 5°0'E); and Kwara (savanna, located between latitude 7°45'N and 9°30'N and longitude 2°30' and 6°25'E). The three sites fall within the tropical wet and dry climate of Koppen's climate classification, dominated by a wet and a dry season. There are, however, some variations between sites. The climate of Ondo State corresponds to a lowland tropical rain forest type, with a mean monthly temperature ranging from 19 °C to 30 °C (mean monthly value of 27 °C) and a mean relative humidity 75% (Owoeye and Sekumade 2016). The mean annual total rainfall exceeds 2,000 mm. In the northern part of the state, there is marked dry season from November to March with little or no rain, for which the total annual rainfall in the north is of about 1,800 mm (Jamie 2016). Differently, Ogun state is characterized by a tropical climate consisting of two distinct wet and dry seasons. The long dry season extends from November to March. The annual rainfall value ranges between 1,400 and 1,500 mm with a relatively high temperature of an average of 30 °C. The average temperature value varies from one month to another,





**Fig. 1** Study area: Ondo, Ogun, and Kwara states in western Nigeria

with a minimum average of 25.7 °C in July and a maximum of 30.2 °C in February. The humidity is lowest at the peak of the dry season in February usually at 37–54% and highest between June and September with a value of 78–85% (Adeleke et al. 2015). Kwara state (Oladimeji et al. 2015) enjoys an annual rainfall ranging from 1,000 mm to 1,500 mm with the rainy season beginning at the end of March and lasting until September while the dry season starts in October and ends in March (Oriola et al. 2010). The temperature of the state is uniformly high and ranges between 25 °C and 30 °C throughout the wet season except for July and September in which the cloud cover prevents direct insolation. In the dry season, the temperature ranges between 33 °C and 34 °C. In the rainy season, the relative humidity in Kwara state ranges between 75% and 80% while in the dry season it is about 65% (Akpenpuan and Busari 2013).

Ondo is an agrarian state with large-scale production of crops like cocoa, yam, cocoa, coffee, and rubber and huge forest reserves of about 2,008 km<sup>2</sup> which produce timbers for furniture, fuelwood, and industrial uses. Ogun is also an agrarian state with the production of arable crops like maize, rice, cassava, and melon. Several other identifiable modern economic activities exist in Ogun, including insurance, motor companies, petrol stations, and light and heavy industries. The major economic activity of Kwara state is farming, with a particular predominance of cash crops like cocoa, coffee, kolanut, tobacco, beniseed, and palm. Food crops like cereals (rice, maize, millet) and tuber crops (yam, cassava, cocoyam, etc.) are grown in Kwara (Oluwasusi and Tijani 2013).

Daily climatic data of rainfall and minimum and maximum temperatures were used for this study. The data, spanning for a period of 37 years (1982–2017), were collected from the synoptic stations (Fig. 1) located at Akure (Ondo state), Ilorin (Kwara state), and Abeokuta (Ogun state). The data were collected by the Nigerian Meteorological Agency (NIMET) at the stations using the British Standard Rain gauge and Dine's tilting siphon rainfall recorder for rainfall and thermometer for temperature. To establish the pattern of climate, a year running mean was used in the analysis to show the annual fluctuation of rainfall and temperature. Mean of daily data were averaged to get the annual mean for temperature (minimum and maximum) and rainfall using MS Excel. Sigma Plot (Version 10.2) was used to plot the graph for annual rainfall, and minimum and maximum temperature against the year covering the study period; the curves were then fitted to show the linear trend. Three crops, that is, maize (cereal), rice (cereal), and cassava (tuber), were used for this study. In this research, climate factors are seen as one of the important requirement for the yield of the crops, as normal seasonal water requirements of maize, for example, is between 400 and 600 mm (Phiri et al. 2003). Maize and rice are common crops in all three zones. Crop yield data were obtained from the archives of Agricultural Development Project (ADP) offices in Ondo, Ogun, and Kwara states. Data were analyzed using the Pearson correlation coefficient between crop yields and climatic data. This was done using the formula below:

$$r = \frac{N \sum xy - (\sum x)(\sum y)}{\sqrt{[\sum x^2 - (\sum x)^2][N \sum y^2 - (\sum y)^2]}}$$

where  $N$  is the number of pairs of scores,  $\sum xy$  is sum of the products of paired scores,  $\sum x$  is sum of scores,  $\sum y$  is sum of  $y$  scores,  $\sum x^2$  is sum of squared  $x$  scores,  $\sum y^2$  is sum of squared  $y$  scores,  $x$  is the crop yield, and  $y$  is the climate data.

Social survey data for the study were collected from farmers with the aid of questionnaires and focus group discussion. Our survey instrument was designed to assess farmer's adaptive capacity. Data were collected among farmers who are purposively selected across the three states under consideration. Criteria for inclusion in our sample were to be in a settlement where maize, rice, and cassava are cultivated and to be 30 years and above. These criteria ensured the collection of data among experienced farmers who had witnessed different farming seasons. The responses from the questionnaires were analyzed using both descriptive and inferential statistics. The major aim of social survey is to obtain information from the farmers on how the yields have been over the years and compare it with changes in climate.

---

## Annual Variability in Rainfall and Minimum and Maximum Temperature

Rainfall data for a 37 years period revealed a variation in the annual mean amount of rainfall (Fig. 2). Rather than an absolute change, results for all the three stations show rainfall variability. The rainfall in Kwara is below normal, a little above normal

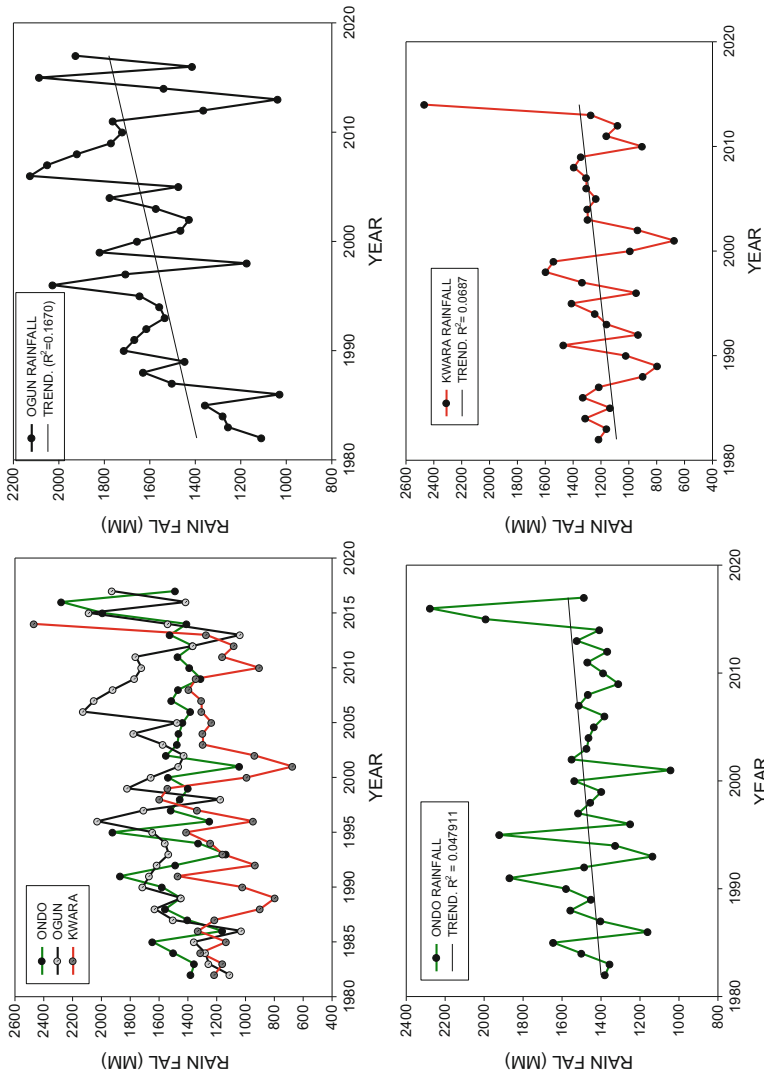


Fig. 2 Rainfall variability in the study area

in Ogun, and varied in Ondo. The rainfall variability found in the data can be attributed to seasonal and interannual climatic variability, which is much more several particularly in the savannah region where Kwara is located (Adejuwon 2004; Odekunle et al. 2007; Ayanlade 2009). As depicted in Fig. 2, annual rainfall was mostly below average before 2010, but varies greatly in the last decade, with readings above average in all the stations. Rainfall peaked in 1991 (with 1,982 mm) and 1995 (1,999 mm) in Ondo state, with 2016 (2,206 mm) recording the highest rainfall during the study period (Fig. 2). In Ogun state, rainfall peaked in 1996 (2,026 mm), 2006 (2,216 mm), and 2015 (2,086 mm), with 2006 recording the highest rainfall. Finally, in Kwara, rainfall peaked in 1991 (1,468 mm), 1995 (1,409 mm), 1998 (1,596 mm), and 1999 (1,539 mm), with the highest peak recorded in 2014 (2,467 mm) with a very unusual high value. Generally, the annual average of rainfall was lowest (673 mm) in Kwara state, with similar values in Ogun (1,028 mm in 1986 and 1,037 mm in 2013) and Ondo states (1,041 mm). Values follow an expected pattern, with higher values in the rainforest ecological zone close to the ocean and lower values in inward zones closer to the savanna. Ogun state received the highest rainfall between 1995 and 2010. The highest rainfall within a year was recorded in 2014 in Kwara, the state belonging to Guinea savanna ecological zone, which recorded a value slightly above the peak of rainfall in Ondo (which belongs to the forest ecological zone).

Climatic variability in the study area can be linked to global climate oscillating systems as El Niño – Southern Oscillations, sea surface temperatures (SSTs), and Inter-Tropical Discontinuity (ITD) have been reported to be responsible for inter-annual variability in Africa climate (Stige et al. 2006). Such climate variability can cause negative departures from normal climate, as documented in a part of Nigeria and elsewhere (Ashipala 2013; Owusu et al. 2015; Ayanlade et al. 2018a). Studies have further revealed that rainfall associated with SST strongly influences rainfall variability in Nigeria in conjunction with the role of the ITD as the equatorial displacement of the Atlantic Subtropical High suppresses the northward summer migration of the ITD thereby resulting into rainfall variability (Bello 2008; Ayanlade et al. 2019).

High variability was observed in the maximum temperature of all stations between 1982 and 2017 (Fig. 4). The temperature was highest in Kwara state, the northernmost state which falls within the Guinea savanna – an area dominated with relatively low rainfall and high temperature – and lowest in Ondo state, the southernmost state. Ondo and Ogun state recorded temperatures below average between 1982 and 2010. However, temperatures have experienced an increase from 2012 till date, especially in Ogun state with the temperature higher gradually increases. As shown in Fig. 3, all the stations experienced similar minimum temperatures patterns from the early 1980s. Temperature oscillations in the maximum temperature were recorded between 1990 and 2010 in Ondo and Ogun with an upward trend observed only in Kwara, though from 2010, the temperature has generally increased in all stations (Figs. 3 and 4).

As shown in Fig. 3, the annual minimum temperature is highest in Ogun state with the lowest value in 1994 (22.8 °C), a value that coincides with the highest

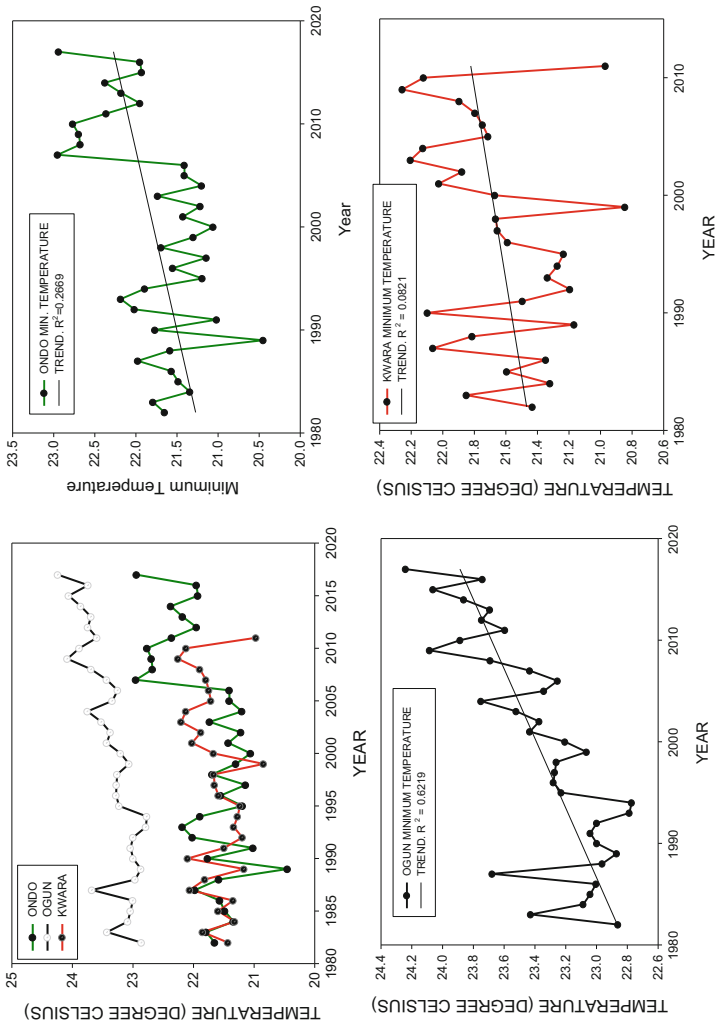


Fig. 3 Minimum temperature variability

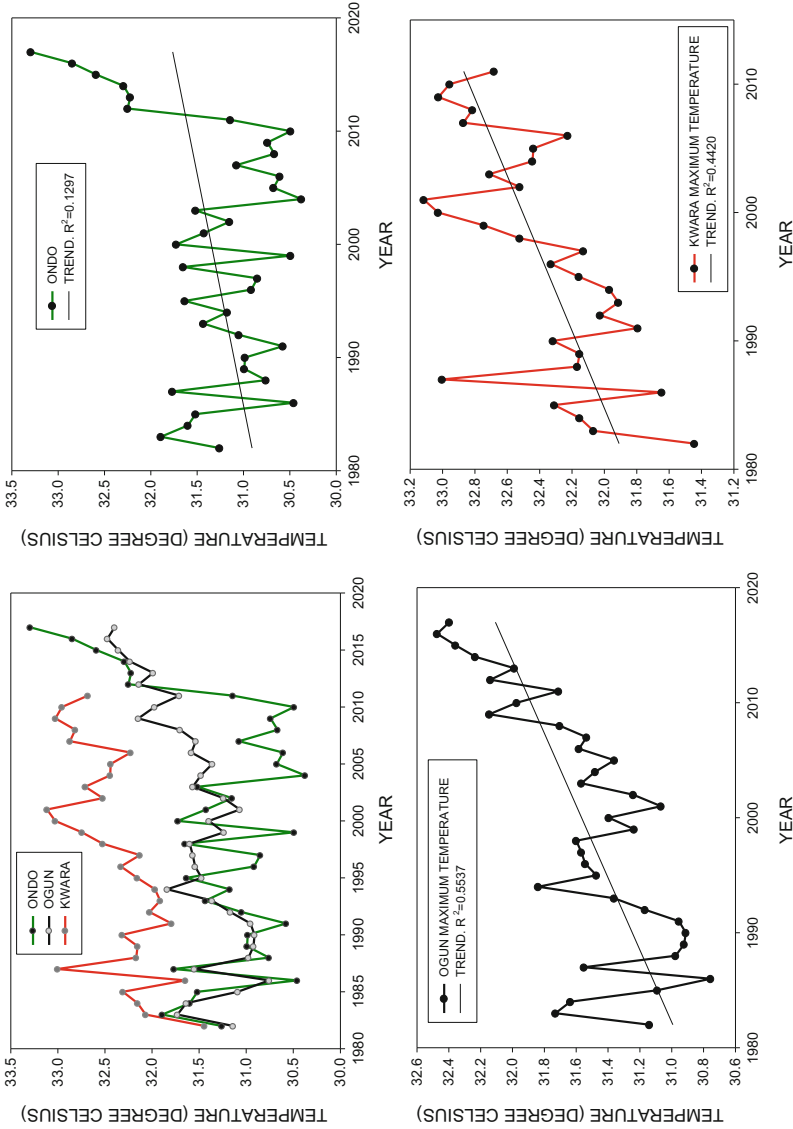


Fig. 4 Maximum temperature variability

minimum temperature in Ondo state. Despite the southern location of Ogun state, the minimum temperature is generally above the minimum temperature for the other two stations, among which Ondo displays the lowest temperature than Kwara. These values represent the highest temperature difference in Kwara and the lowest temperature difference in Ogun state. The period of temperature increase in Kwara state (i.e., years 2000, 2001, and 2002) corresponds to the period of rainfall decrease which could be attributed to increasing temperature and decreasing rainfall as a result of the increasing evapotranspiration and desertification also reported in other areas of Nigeria (Ayoade 2003). The trend of the maximum temperature varies considerably in all stations. However, while the trend is irregular in the early years of the study period, an upward increasing trend was observed in the later years. This recent increase in temperature could be linked to the effect of changes in climate and to the rapid urbanization in the ecological zones under consideration (Mabo 2006).

## Relationship Between Climate and Crop Yield

The results of the Pearson correlation analysis between annual minimum temperature and crop yields during the growing season are shown in Table 1. Annual minimum temperature had positive but weak correlation with maize in Ondo (0.142) but not significant at  $p < 0.05$ , a weak and not statistically significant negative correlation of  $-0.078$  at  $p < 0.05$  in Ogun state, and a positive correlation of 0.219 in Kwara at  $p < 0.05$ . Rice, on the other hand, had a positive but weak correlation of 0.167 which is statistically not significant at  $p < 0.05$  in Ondo state while in Ogun state with a positively strong and statistically significant correlation coefficient of 0.674 at  $p < 0.05$  and a strong positive and statistically significant correlation coefficient of 0.481 in Kwara state at  $p < 0.05$ . The correlation coefficient for cassava in Ondo state is a weak and statistically not significant value of 0.22 at  $p < 0.05$  while a strong positive and statistically significant correlation coefficient of 0.82 at  $p < 0.05$  in Ogun and a positive but not significant correlation of 0.25 at  $p < 0.05$ . Generally, annual minimum temperature had a strong, positive, and statistically significant correlation coefficient at  $p < 0.01$  and  $p < 0.05$  in rice for Ogun and Kwara states and cassava only in Ogun state.

Table 2 shows the result of Pearson correlation analysis between annual maximum temperature and crop yields during the study period. The annual maximum temperature had a positive weak and statistically not the significant relationship with maize in Ondo (0.198) at  $p < 0.05$ , a weak and not statistically significant negative

**Table 1** Correlation between minimum temperature and crop yield

	Maize	Rice	Cassava
Ondo	0.142	0.167	0.220
Ogun	$-0.078$	0.674*	0.820*
Kwara	0.219	0.481*	0.248

\*Significant at  $p < 0.05$

**Table 2** Correlation between maximum temperature and crop yield

	Maize	Rice	Cassava
Ondo	0.198	0.160	-0.115
Ogun	-0.337	0.884**	0.870**
Kwara	0.342	0.773**	0.626**

\*Significant at  $P \leq 0.05$ ; \*\*Significant at  $P \leq 0.01$

**Table 3** Correlation between rainfall and crop yield

	Maize	Rice	Cassava
Ondo	-0.151	-0.091	-0.076
Ogun	0.003	0.136	0.046
Kwara	0.08	-0.220	0.064

\*Significant at  $P \leq 0.05$ ; \*\*Significant at  $P \leq 0.01$

correlation of  $-0.337$  at  $p < 0.05$  in Ogun state, and a positive correlation of  $0.342$  in Kwara at  $p < 0.05$ . Rice had a positive but weak correlation of  $0.160$  which is statistically not significant at  $p < 0.05$  in Ondo state while in Ogun state with a positive, very strong, and statistically significant correlation coefficient of  $0.88$  at  $p < 0.05$  and a very strong positive and statistically significant correlation coefficient of  $0.77$  in Kwara state at  $p < 0.05$ . The correlation coefficient for cassava in Ondo state is a negative, weak, and statistically not significant value of  $-0.12$  at  $p < 0.05$  while a very strong positive and statistically significant correlation coefficient of  $0.87$  at  $p < 0.05$  in Ogun. A positive and significant correlation of  $0.63$  at  $p < 0.05$ . Generally, the annual maximum temperature had a strong, positive, and statistically significant association with rice and cassava yields in Ogun and Kwara states but not in Ondo state. The maximum temperature was not associated with maize yields in any of the states.

The result of the Pearson correlation analysis between annual rainfall and crop yields during the study period is shown in Table 3. Annual rainfall had a negative, weak, and statistically not a significant relationship of  $-0.15$  with maize Ondo at  $p < 0.05$ , a weak and not statistically significant positive correlation of  $0.003$  at  $p < 0.05$  in Ogun state and a positive correlation of  $0.08$  in Kwara at  $p < 0.05$ . Rice showed a negative but weak correlation of  $-0.091$  which is statistically not significant at  $p < 0.05$  in Ondo state while in Ogun state with a positive, weak, and statistically significant correlation coefficient of  $0.14$  at  $p < 0.05$  and a weak, negative, and statistically not significant correlation coefficient of  $-0.22$  in Kwara state at  $p < 0.05$ . The correlation coefficient for cassava in Ondo state is a negative, weak, and statistically not significant value of  $-0.08$  at  $p < 0.05$  while a positive and statistically not significant correlation coefficient of  $0.046$  at  $p < 0.05$  in Ogun was observed. And a positive, weak, and not the significant correlation of  $0.06$  at  $p < 0.05$  was observed for Kwara state. Generally, annual rainfall had a weak and statistically not significant association with maize, rice, and cassava yields in the three studied states.



### Farmer’s Adaptive Strategies

Figure 5 shows the percentage error graph of farmers’ coping or adaptive capacity toward extreme climatic conditions. According to our results, 16.7% of the respondents are engaged in agricultural diversification, 17.3% are engaged in changing the crops they cultivate, 20.2% are engaged crop rotation, and 19.6% are practicing mixed farming.

As shown in Fig. 5, the farmers are coping or adapting to extreme climatic conditions but generally with low capacity. This is because the results show that 19% of farmers had implemented changes in the size of farmland, 14.9% are engaged in different crop composition, 33.3% are engaged in agricultural intensification, 30.4% are engaged in bush fallowing, 29.8% are changing the daily working time, 47.6% are presently engaged in agroforestry, 27.4% are changing the seasonal timing of sowing, 41.1% are changing the harvest time, 35.7% are into irrigation, 31.5% are into the use of fertilizer, 32.1% are into the use of pesticide, 56.5% are into getting loan and credit facilities, 32.7% are into getting other sources of income so as not to depend on their farm only, 44% are changing the method of storing their food, 27.4% are changing the quantity of food consumed by the family, and 24.4% are changing the quantity of food consumed by the family, and 24.4%

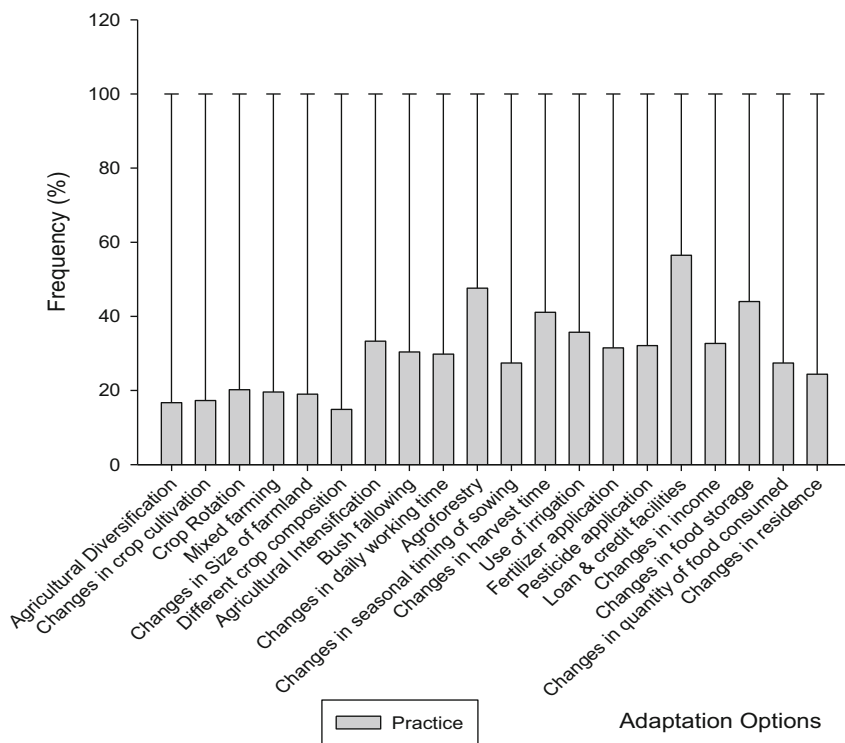


Fig. 5 Adaptation strategies adopted by farmers in the region

are changing their residence by moving to another area for farming. From Fig. 5, seeking for loans and credit facilities, changes in food storage, agroforestry, changing the time of harvest, use of irrigation, use of fertilizer, and agricultural intensification, among others, are the most practiced adaptation options.

---

## Conclusion

The effects of climate variability or climate change on selected crops in selected ecological zones in Nigeria were examined in this study. Results show that minimum temperature, maximum temperature, and rainfall varied both spatially and temporally. The annual minimum temperature, maximum temperature, and rainfall showed that there is the year-to-year fluctuation with pronounced peaks and depressions. While some years show upward trends, some showed a downward trend. Also, there is the month to month variability in minimum temperature, maximum temperature, and rainfall. Crop yields did not depend on rainfall and minimum and maximum temperatures alone. In all the stations, maize yields were less sensitive to minimum temperature than rice and cassava yields. While there appears a negative but weak relationship that is not statistically significant between minimum temperature and maize in Ogun, it has a positive but weak relationship in Ondo and Kwara. Maximum temperature showed a strong positive and statistical association with rice and cassava yields in Ogun and Kwara states. Finally, rainfall was associated with maize, rice, or cassava yields in any state. Many other studies have reported the similar finding of the climate-crops relationships in China (Zhang et al. 2016; Gao et al. 2019; Ding et al. 2020), Southern Africa (Mafongoya et al. 2017; Nhamo et al. 2019) and East African countries (Sridharan et al. 2019; Thomas et al. 2019). These results dovetail with results from previous research. Thus, although an increasing trend in rainfall and temperature may affect rice yields, a study in Bangladesh showed that despite an increasing rainfall and temperature, the yield of rice is not negatively affected (Rahman et al. 2017). Matched with the results of the present study, the rainfall can, therefore, have a positive or negative impact on the yield of crops depending on its distribution and intensity over the growing season. Furthermore, the present study revealed that farmers' perception of climate variability/change impacts on crop yield varied spatially. The majority of farmers believed that average temperature of the coldest month, rain generally, rain during the rainy season, and rain during the dry season were believed to have changed in recent years in Ogun and Kwara by higher numbers of respondents, while statistical analyses showed that there is variation while in Ondo state, the farmers believe that "the temperature is warmer generally, the temperature of the hottest season is warmer, rain is higher in the rainy and dry seasons with extreme drought less frequent, onset earlier, rainy season duration longer." The temperature of the hottest month was believed, though, to be warmer by a higher proportion, as claimed by the farmers. Many believe that extreme floods are more frequent while extreme drought and duration of the rainy and dry seasons have remained the same. According to Tripathi and Mishra (2017), farmers are aware of long-term changes in climatic factors

(temperature and rainfall) but are unable to identify those changes as climate change. However, many farmers are not taking concrete steps in dealing with perceived change in climate but are changing their agricultural and farming practices (Ayanlade et al. 2018a) which can be said to be passive response to climate change. Farmers' perception of climate is probably responsible for low adaptation to climate change.

**Acknowledgments** This study is part of the research project carried out with the aid of a grant from the International Development Research Centre, Ottawa, Canada, and with financial support from the Government of Canada, provided through Global Affairs Canada (GAC), under the framework of the Mathematical Sciences for Climate Change Resilience (MS4CR) program administered by AIMS (2018 cohort of AIMS). The research was also partly funded by an ERC Consolidator Grant to Reyes-García (FP7-771056-LICCI).

---

## References

- Adamgbe E, Ujoh F (2013) Effect of variability in rainfall characteristics on maize yield in Gboko, Nigeria. *J Environ Prot* 4:881
- Adejuwon JO (2004) Crop yield response to climate variability in the Sudano-Sahelian ecological zones of Nigeria in southwestern Nigeria. In: AIACC report of workshop for Africa and Indian Ocean Island. Dakar, Senegal pp (15–16)
- Adejuwon JO (2005) Food crop production in Nigeria. I. Present effects of climate variability. *Clim Res* 30:53–60
- Adejuwon JO (2012) An assessment of the effect of climate variability on selected agricultural practices and yields in Sokoto-Rima River Basin, Nigeria. PhD thesis, Obafemi Awolowo University, Ile-Ife
- Adeleke O, Makinde V, Eruola A, Dada O, Ojo A, Aluko T (2015) Estimation of groundwater recharges in Odeda local government area, Ogun state, Nigeria using empirical formulae. *Challenges* 6:271–281
- Adenle AA, Ford JD, Morton J, Twomlow S, Alverson K, Cattaneo A, Cervigni R, Kurukulasuriya P, Huq S, Helfgott A (2017) Managing climate change risks in Africa – a global perspective. *Ecol Econ* 141:190–201
- Agboola AM, Ayanlade A (2016) Sea level rise and its potential impacts on coastal urban area: a case of Eti-Osa, Nigeria. *An Univ Oradea Ser Geogr* 27:188–200
- Ajetomobi J (2016) Sensitivity of crop yield to extreme weather in Nigeria. No 310-2016-5403 2016
- Akpenpuun T, Busari R (2013) Impact of climate on tuber crops yield in Kwara state, Nigeria. *Am Int J Contemp Res* 3:52–57
- Ashipala SN (2013) Effect of climate variability on pearl millet (*Pennisetum glaucum*) productivity and the applicability of combined drought index for monitoring drought in namibia. A Dissertation submitted for the award of M.Sc Agricultural Meteorology, University of Nairobi, Nairobi, Kenya
- Ayanlade A (2009) Seasonal rainfall variability in Guinea Savanna part of Nigeria: a GIS approach. *Int J Clim Change Strateg Manage* 1:282–296
- Ayanlade A (2017) Variations in urban surface temperature: an assessment of land use change impacts over Lagos metropolis. *Weather* 72:315–319
- Ayanlade A, Ojebisi SM (2020) Climate variability and change in Guinea Savannah ecological zone, Nigeria: assessment of cattle herders' responses. In: Leal Filho W (ed) *Handbook of climate change resilience*. Springer International Publishing, Cham

- Ayanlade A, Odekunle T, Orimogunje O, Adeoye N (2009) Inter-annual climate variability and crop yields anomalies in Middle Belt of Nigeria. *Adv Nat Appl Sci* 3:452–465
- Ayanlade A, Radeny M, Morton JF (2017) Comparing smallholder farmers' perception of climate change with meteorological data: a case study from southwestern Nigeria. *Weather Clim Extrem* 15:24–33
- Ayanlade A, Radeny M, Akin-Onigbinde AI (2018a) Climate variability/change and attitude to adaptation technologies: a pilot study among selected rural farmers' communities in Nigeria. *GeoJournal* 83:319–331
- Ayanlade A, Radeny M, Morton JF, Muchaba T (2018b) Rainfall variability and drought characteristics in two agro-climatic zones: an assessment of climate change challenges in Africa. *Sci Total Environ* 630:728–737
- Ayanlade A, Atai G, Jegede MO (2019) Variability in atmospheric aerosols and effects of humidity, wind and intertropical discontinuity over different ecological zones in Nigeria. *Atmos Environ* 201:369–380
- Ayoade J (2003) Climate change: a synopsis of its nature, causes, effects and management. Vantage Publishers, Ibadan
- Bello NJ (2008) Perturbations in the plant environment: the threats and agro-climatological implications for food security. University of Agriculture, Abeokuta
- Ding Y, Wang W, Zhuang Q, Luo Y (2020) Adaptation of paddy rice in China to climate change: the effects of shifting sowing date on yield and irrigation water requirement. *Agric Water Manag* 228:105890
- Fourcade Y, Åström S, Öckinger E (2019) Climate and land-cover change alter bumblebee species richness and community composition in subalpine areas. *Biodivers Conserv* 28:639–653
- Gao J, Yang X, Zheng B, Liu Z, Zhao J, Sun S, Li K, Dong C (2019) Effects of climate change on the extension of the potential double cropping region and crop water requirements in Northern China. *Agric For Meteorol* 268:146–155
- Harvey CA, Saborio-Rodríguez M, Martínez-Rodríguez MR, Viguera B, Chain-Guadarrama A, Vignola R, Alpizar F (2018) Climate change impacts and adaptation among smallholder farmers in Central America. *Agric Food Secur* 7(1):57
- Hein Y, Vijitsrikamol K, Attavanich W, Janekarnkij P (2019) Do farmers perceive the trends of local climate variability accurately? An analysis of farmers' perceptions and meteorological data in Myanmar. *Climate* 7:64
- Heltberg R, Siegel PB, Jorgensen SL (2009) Addressing human vulnerability to climate change: toward a 'no-regrets' approach. *Glob Environ Chang* 19:89–99
- IPCC (2007) Climate Change 2007 – impacts, adaptation and vulnerability. Contribution of working group ii to the fourth assessment report of the IPCC (eds: Parry ML, Canziani OF, Palukitof JP, Van der Linden PJ, Hanson CE). Cambridge University Press, Cambridge
- Jamie T (2016) Ondo state. [https://en.wikipedia.org/wiki/Ondo\\_State](https://en.wikipedia.org/wiki/Ondo_State). Accessed 24 Oct 2018
- Mabo C (2006) Temperature variation in northern Nigeria between 1970 and 2000. *J Energy Environ* 19:80–88
- Mafongoya PL, Peerbhay K, Jiri O, Nhamo N (2017) Climate scenarios in relation to agricultural patterns of major crops in Southern Africa. In: Smart technologies for sustainable smallholder agriculture (pp 21–37). Academic Press
- Molua EL (2020) Africa in a changing climate: redefining Africa's agrarian development policies. In: Climate variability and change in Africa (pp 171–181). Springer, Cham
- Morton J (2017) Climate change and African agriculture: unlocking the potential of research and advisory services. In: Nunan F (ed) Making climate compatible development happen (pp 109–135). Routledge
- Moylan H (2012) The impact of rainfall variability on agricultural production and household welfare in rural Malawi. In: Uo I (ed) Urbana-Champaign. University of Illinois, Illinois
- Nhamo L, Matchaya G, Mabhaudhi T, Nhlengethwa S, Nhemachena C, Mpandeli S (2019) Cereal production trends under climate change: impacts and adaptation strategies in southern Africa. *Agriculture* 9:30
- Odekunle T, Orinmoogunje I, Ayanlade A (2007) Application of GIS to assess rainfall variability impacts on crop yield in Guinean Savanna part of Nigeria. *Afr J Biotechnol* 6:2100

- Oladimeji Y, Abdulsalam Z, Abdullahi A (2015) Determinants of participation of rural farm households in non-farm activities in Kwara state, Nigeria: a paradigm of poverty alleviation. *Ethiop J Environ Stud Manag* 6:635–649
- Oluoko-Odingo AA (2011) Vulnerability and adaptation to food insecurity and poverty in Kenya. *Ann Assoc Am Geogr* 101:1–20
- Oluwasuji J, Tijani S (2013) Farmers adaptation strategies to the effect of climate variation on yam production: a case study in Ekiti state, Nigeria. *Agrosearch* 13:20–31
- Oriola E, Ifabiyi I, Hammed A (2010) Impact of reforestation in a part of degrading natural ecological system of Ilorin, Kwara state, Nigeria. *Afr J Agric Res* 5:2811–2816
- Owoeye R, Sekumade A (2016) Effect of climate change on cocoa production in Ondo state, Nigeria. *J Soc Sci Res* 10:2014–2025
- Owusu K, Obour PB, Asare-Baffour S (2015) Climate variability and climate change impacts on smallholder farmers in the Akuapem North District, Ghana. In: *Handbook of climate change adaptation* (pp 1791–1806). Berlin: Springer
- Pablo M, Antonio Y (2015) The effect of rainfall variation on agricultural households. In: *International conference of agricultural economists*, Milan
- Phiri E, Verplancke H, Kwesiga F, Mafongoya P (2003) Water balance and maize yield following improved sesbania fallow in eastern Zambia. *Agrofor Syst* 59:197–205
- Rahman MA, Kang S, Nagabhatla N, Macnee R (2017) Impacts of temperature and rainfall variation on rice productivity in major ecosystems of Bangladesh. *Agric Food Secur* 6:10
- Sanchez PA (2000) Linking climate change research with food security and poverty reduction in the tropics. *Agric Ecosyst Environ* 82:371–383
- Seaman JA, Sawdon GE, Acidri J, Petty C (2014) The household economy approach. Managing the impact of climate change on poverty and food security in developing countries. *Clim Risk Manag* 4:59–68
- Serdeczny O, Adams S, Baarsch F, Coumou D, Robinson A, Hare W, Schaeffer M, Perrette M, Reinhardt J (2017) Climate change impacts in sub-Saharan Africa: from physical changes to their social repercussions. *Reg Environ Chang* 17:1585–1600
- Sowunmi F, Akintola J (2010) Effect of climatic variability on maize production in Nigeria. *Res J Environ Earth Sci* 2:19–30
- Sridharan V, Pereira Ramos E, Zepeda E, Boehlert B, Shivakumar A, Taliotis C, Howells M (2019) The impact of climate change on crop production in Uganda – an integrated systems assessment with water and energy implications. *Water* 11:1805
- Stige LC, Stave J, Chan KS, Ciannelli L, Pettoelli N, Glantz M, Stenseth NC (2006) The effect of climate variation on agro-pastoral production in Africa. *Proceedings of the National Academy of Sciences* 103(9):3049–3053
- Thomas TS, Dorosh PA, Robertson RD (2019) Climate change impacts on crop yields in Ethiopia, vol 130. *International Food Policy Research Institute*, Washington, DC
- Tripathi A, Mishra AK (2017) Knowledge and passive adaptation to climate change: an example from Indian farmers. *Clim Risk Manag* 16:195–207
- Varela MR, Patricio AR, Anderson K, Broderick AC, DeBell L, Hawkes LA, Tilley D, Snape RT, Westoby MJ, Godley BJ (2019) Assessing climate change associated sea-level rise impacts on sea turtle nesting beaches using drones, photogrammetry and a novel GPS system. *Glob Chang Biol* 25:753–762
- Wright H, Vermeulen S, Laganda G, Olupot M, Ampaire E, Jat M (2014) Farmers, food and climate change: ensuring community-based adaptation is mainstreamed into agricultural programmes. *Clim Dev* 6:318–328
- Zhang Z, Song X, Tao F, Zhang S, Shi W (2016) Climate trends and crop production in China at county scale, 1980 to 2008. *Theor Appl Climatol* 123:291–302

**Open Access** This chapter is licensed under the terms of the Creative Commons Attribution 4.0 International License (<http://creativecommons.org/licenses/by/4.0/>), which permits use, sharing, adaptation, distribution and reproduction in any medium or format, as long as you give appropriate credit to the original author(s) and the source, provide a link to the Creative Commons license and indicate if changes were made.

The images or other third party material in this chapter are included in the chapter's Creative Commons license, unless indicated otherwise in a credit line to the material. If material is not included in the chapter's Creative Commons license and your intended use is not permitted by statutory regulation or exceeds the permitted use, you will need to obtain permission directly from the copyright holder.





# Plants and Plant Products in Local Markets Within Benin City and Environs

# 18

Moses Edwin Osawaru and Matthew Chidozie Ogwu

## Contents

Introduction .....	316
Plants and Plant Products in Local Markets: The Case of Benin City and Environs .....	318
References .....	335

## Abstract

The vulnerability of agriculture systems in Africa to climate change is directly and indirectly affecting the availability and diversity of plants and plant products available in local markets. In this chapter, markets in Benin City and environs were assessed to document the availability of plants and plant products. Markets were grouped into urban, suburban, and rural with each group having four markets. Majority of the plant and plant product vendors were women and 88 plant species belonging to 42 families were found. Their scientific and common names were documented as well as the parts of the plant and associated products available in the markets. Most of the plant and plant products found in local

This chapter was previously published non-open access with exclusive rights reserved by the Publisher. It has been changed retrospectively to open access under a CC BY 4.0 license and the copyright holder is “The Author(s)”. For further details, please see the license information at the end of the chapter.

M. E. Osawaru

Department of Plant Biology and Biotechnology, Faculty of Life Sciences, University of Benin, Benin City, Edo State, Nigeria

M. C. Ogwu (✉)

Department of Plant Biology and Biotechnology, Faculty of Life Sciences, University of Benin, Benin City, Edo State, Nigeria

Scuola di Bioscienze e Medicina Veterinaria, Università di Camerino – Centro Ricerche Floristiche dell’Appennino, Parco Nazionale del Gran Sasso e Monti della Laga, Barisciano (L’Aquila), Italy  
e-mail: [matthew.ogwu@uniben.edu](mailto:matthew.ogwu@uniben.edu)

markets belong to major plant families. Urban markets had the highest diversity of plants and plant products. Three categories of plants and plant products were documented. Around 67% of the plants and plant products were categorized as whole plant/plant parts, 28% as processed plant parts, while 5% as reprocessed plant/plant parts. It was revealed that 86% of these plants are used as foods, 11% are for medicinal purposes, while 3% is used for other purposes. About 35% of plants and plant products across the markets were fruits, which is an indication that city and environs are a rich source of fruits. The local knowledge and practices associated with the plants and plant products can contribute towards formulating a strategic response for climate change impacts on agriculture, gender, poverty, food security, and plant diversity.

---

**Keywords**

Climate change · Ethnobotany · Plant diversity · Plant products · Food security · Market survey · Indigenous plants species · Economic plants · Agriculture vulnerability · Sustainable development

---

**Introduction**

The utilitarian nature of humans is driving the massive extinction of biodiversity, climate change, and ecological vulnerability. However, a greater understanding of plant-human interactions can contribute to sustainable development, addressing climate change and biodiversity loss, food security, and poverty reduction. All plants are considered important and can potentially serve to fulfill one or more of our basic needs – food, shelter, and clothing as well as environmental integrity. Plant product refers to goods and services derivable from plants and may include whole plant or plant part (used as ingredients and condiments). Proper local and scientific identification of plant materials is necessary to determine and predict the role of a plant and this will require a general knowledge of botany, sociology, and anthropology. Plant is essential for our continued survival on earth as they directly or indirectly provide food for survival, medicine, fibers, chemical products, and other commodities as well as to protect and maintain the environment against erosion, used to cure disease and relieve from suffering. Many industries are dependent on plants for their raw materials. Some of the most outstanding materials of modern civilization are obtained from plants, such as wood, tanning materials and dyestuffs, oils, resins, gums, varnishes, beverages, etc. Plants provide raw material for industrialization and are basis of the green revolution and a pillar for food security. The esthetic value of plants has no small influence on man's overall life satisfaction, as evidenced by the host of garden enthusiasts and flower lovers. Plants are also the basis of a vegan lifestyle.

In the economy of nature, the production and distribution of plant products have a profound influence on the environmental, economic, and social life of a nation with both domestic and international influence. The maintenance of an adequate supply of



food and plant-based industrial raw materials is essential to the existence, as well as the prosperity, of any nation (Burkill 1985). Additionally, plants also have important roles in the tribal, social and cultural life of man (Osawaru and Dania-Ogbe 2010; Osawaru and Ogwu 2014a). Local markets are an integral part of life and cultural practice of the people especially in developing countries as a social, economic, and ecological institution. Plant products available in the market can be used as an indicator for biodiversity richness, climate changes effects, and agricultural vulnerabilities. This is more important in Africa, which according to Ogwu (2019) the environment and agriculture systems are most vulnerable climate change. Markets in rural parts of Africa are often scheduled at considerable day interval, whereas in urban and semi-urban centers, it is mostly open every day or night. Sellers have their stalls or place while hawkers also patrol the market with their various plants and plant products. Markets are rich sources of information on plants and plant products as well as an easily accessible and cost-effective place for plant-based fieldwork and germplasm collection. Markets can provide qualitative and quantitative data concerning cultural, social, and economic aspects of a plant's usage (Bye and Linares 1983; Martin 1992; Cunningham 2001). Moreover, markets are recognized as a vital botanical record of the history of useful plants in a region (Whitaker and Cutler 1966). They are places of intensive interaction between people and plants.

Local traders (mostly women) are very knowledgeable about the uses of plants and their seasonal availability. This knowledge is vital in the global response to global climate change and massive loss of biodiversity in this sixth extinction era. In Nigeria and West Africa, market vendors are known to deal in certain types of plants and plant product and are found clustered together, which imposes a sort of market influence such as fixed prices for their commodities. However, traders have certain concession such as monopoly to regular customer and slight price variations. Moreover, the survey of marketplaces provides information about food and nutritional value of plant and products as well as their ethnobotany (Nguyen 2005). Findings from such studies have been used to draw interesting conclusions and hypothesize about human-environmental-plant interactions and relationships. Climate change, migration, and economic forces can influence the availability of certain plant and plant products in the market. Obiri and Addai (2007) surveyed economic plants in Kumasi central market and documented a total of 150 plant species from 55 families most of them had multiple uses – 57% and 20% used for medicinal and food purposes, respectively. Idu et al. (2010) documented the medicinal plants sold in markets in Abeokuta, Nigeria, revealed 60 medicinal plant species used for traditional health management. The ethnobotanical survey of Yaradua and El-Ghani (2015) reported 54 plants belonging to 33 families from Katsina metropolis markets. The objective of this chapter is to identify and document the plants and plant products sold in local markets in Benin City and environs.

This chapter will compare the diversity of the plants and plant products available in local markets in urban, peri-urban, and rural centers in Benin City, Southern Nigeria. Thereafter, this chapter will categorize the plants and plant products based on the level of processing it was subjected to as well as their taxonomic families. The results will seek to promote local markets as a reservoir of plant germplasm and

contribute towards understanding of how climate change vulnerability is affecting agriculture system in Edo state, diversity of plant and plant-based food materials available in local markets that can potentially contribute to addressing food security, poverty, and sustainable development. It will also highlight the plant parts and plant products sold in the markets.

---

## **Plants and Plant Products in Local Markets: The Case of Benin City and Environs**

There are numerous open markets in Benin City (latitude  $06^{\circ} 19'00''$  E to  $6^{\circ} 21'00''$  E and longitude  $5^{\circ} 34'00''$  E to  $5^{\circ} 44'00''$  E; average elevation of 77.8 m above sea level; 2006 est. pop. 1,147,188 with an annual growth rate of 2.9%), which is one of the oldest cities in Nigeria and the capital of Edo State, Southern Nigeria. It is within the tropical rainforest zone of Nigeria with an estimated area of 550 km<sup>2</sup>. Geologically the city has a sedimentary formation of the Miocene-Pleistocene age. Benin has an undulating topography with a vegetation type characterized by lowland rainforest and an annual average rainfall of 800 mm. A 35-year study by Floyd et al. (2016) revealed massive climate fluctuations especially in average rainfall, temperate, humidity and suggested that it is impacting plant production and environmental changes due to soil erosion. The fluctuation is attributed to high anthropogenic activities in Benin City (Efe and Eyefia 2014). With increased warming, flooding, and urbanization, agriculture and food production are threatened in Benin City (Atedhor et al. 2011).

Benin is the center of Nigeria's rubber industry, but processing palm nuts for oil is also an important traditional industry. Benin has numerous local markets strewn across the city to cater to the needs of its inhabitants as well as to serve as a sales outlet for the numerous farm produce cultivated in the rural areas of the state as well as in urban home gardens. The nodal nature of Benin makes it an ideal place for various commercial activities as these farm produce can be easily transported to cities like Lagos, Abuja, and Port Harcourt. Benin City is endowed with a wide diversity of plants and plant products. The sales of plants and plant products play a key role in the sustenance of livelihoods of people providing income, employment, food, and medicines among others in Benin City and environs. Some of the local markets in Benin City and environs are God's Market (Ekiosa), Oba Market (Ekioba), New Benin Market, Santana Market, Uselu Market (Ediaken Market), Oliha Market, Ugbogiobo Market, Evbuotubu Market, Oregbeni Market (Ikpoba Hill Market), Ekiador Market, Iguobazuwa Market, Ehor Market, and Usen Market.

The sampling frame considered markets within Benin City and environs, which were delimited into three categories according to the status defined by Osawaru and Odin (2012) – urban, peri-urban, and rural. A reconnaissance visit was undertaken to all the local markets in Benin City and environs. Twelve markets were randomly selected for sampling. They consist of four urban, four peri-urban, and four rural markets (Table 1).

**Table 1** Sampling sites for the survey of plants and plant products in Benin City and environs

Market	Category	Local government area
New Benin	Urban	Oredo
Uselu	Urban	Egor
Oba	Urban	Oredo
Oregbene	Urban	Ikpoba-Okha
Evbuotubu	Peri-urban	Egor
Ugbogiobo	Peri-urban	Ovia North East
Ugbiohioko	Peri urban	Egor
Iguobazuwa	Peri-urban	Ovia South West
Ehor	Rural	Uhunnwode
Usen	Rural	Ovia North East
Ekiadolor	Rural	Ovia North East
Ugbogui	Rural	Ovia South West

In each market, ten traders of mixed age and sex were randomly selected and plants and plant products in their stalls were assessed. Each market was visited three times. First, to map out the randomly selected informant, secondly, to administer the questionnaire and inventory the plants and plant products, and finally, to seek clarity for some questions outlined in the questionnaire. Responses via the questionnaires were retrieved from the questionnaires, translated and scored by typing into Microsoft Excel, and analyzed quantitatively. Plants and plant products were categorized according to Osawaru and Odin (2012) i.e.,

1. 1<sup>o</sup> of plants and plant products-whole plant/plant part
2. 2<sup>o</sup> of plant and plant product-processed plant part
3. 3<sup>o</sup> of plant and plant product-reprocessed plant/plant part

Majority of the traders encountered in the markets were women. This confirms the findings of De Caluwe (2011) and Agea et al. (2011) that trading in plant and plant products are dominated by women. In a different study, Osawaru and Ogwu (2014b) also established that women contribute significantly to holding plant germplasm. These findings underscore the importance of women in the fight to address the effects of climate change especially food security and sustainable agriculture. Moreover, the sales of plants and plant products in the different markets were practiced by different tribes and ethnic groups in all the markets surveyed.

A total of 88 plants and plants product was found in all the local markets assessed (Table 2). The botanical and common names, forms, diversity, and categories of the plant and plant products sold in local markets within Benin City and environs are presented in Table 2. These 88 plants and plant product are distributed into 42 families. Presence of plant and plant products varies in the different markets. For instance, *Adansonia digitata*, *Brassica oleracea*, *Cucumis sativus*, *Cucurbita pepo*, *Cyperus esculetus*, *Dialium guineense*, *Ricinus communis*, *Pennisetum glaucum*, *Pentaclathra macrophylla*, *Myristica fragans*, and *Phoenix dactylifera*

**Table 2** Diversity of plants and plant products in 12 local markets within Benin City and environs

Botanical name	Family	Common name	Form/product type	Local name (Bini)	Urban market	
					New Benin	Uselu
<i>Abelmoshus esculentus</i> L.	Malvaceae	Okra		Ikhiav-bo	+	+
<i>Adensonia digitata</i> L.	Malvaceae	Baobab			+	+
<i>Allium cepa</i> L.	Liliaceae	Onion		Alubara	+	+
<i>Allium sativum</i> L.	Liliaceae	Garlic			+	+
<i>Amaranthus caudatus</i> L.	Amaranthaceae	Spinach		Ebaafor	+	+
<i>Anacardium occidentale</i> L.	Anacardiaceae	Cashew			+	—
<i>Ananas comosus</i> L.	Bromeliaceae	Pineapple		Edinebo	+	+
<i>Annona muricata</i> L.	Annonaceae	Soursop			+	+
<i>Arachis hypogaea</i> L.	Fabaceae	Groundnut		Isaerewe	+	+
<i>Azadirachta indica</i> L.	Meliaceae	Neem			—	+
<i>Bombax buonopozense</i> L.	Malvaceae				—	—
<i>Brassica oleracea</i> L.	Brassicaceae	Cabbage			+	+
<i>Calotropis procera</i> Auton.	Apocynaceae				+	+
<i>Capsicum annum</i> L.	Solanaceae	Pepper		Ehien	+	+
<i>Capsicum frutescens</i> L.	Solanaceae	Pepper		Ikpovb-ukho	+	+
<i>Carica papaya</i> L.	Caricaceae	Pawpaw		Uhoro	+	+
<i>Celosia argentea</i> L.	Amaranthaceae	Celosia			+	+
<i>Citrus aurantifolia</i> L.	Rutaceae	Lime		Alimonegiere	+	+
<i>Citrus limon</i> L.	Rutaceae	Lemon			+	+
<i>Citrus sinensis</i> Osbeck	Rutaceae	Orange		Alimebo	+	+
<i>Cochorus olitorius</i> L.	Tiliaceae	Jute			+	+
<i>Cocos nucifera</i> L.	Palmae	Coconut		Ivin	+	+
<i>Cola acuminata</i> Engl.	Sterculiaceae	Kolanuts		Gbanja	+	+
<i>Cola nitida</i> Schum.	Sterculiaceae	Kolanut		Evbedo	+	+
<i>Colocasia esculenta</i> Schott	Araceae	Cocoyam		Akaha	+	+
<i>Crescentia cujele</i> L.	Curcubitaceae	Calabash		Uko	+	+
<i>Cucumeropsis mannii</i> Naudin	Cucurbitaceae	Melon		Ogi	+	+
<i>Cucumis sativus</i> L.	Cucurbitaceae	Cucumber			+	+
<i>Cucurbita pepo</i> L.	Cucurbitaceae				+	+
<i>Cucurma longa</i> L.	Zingiberaceae				+	+
<i>Cymbopogon citrates</i> L.	Poaceae	Lemmon grass		Ebiti	+	+
<i>Cyperus esculentus</i> L.	Cyperaceae	Tiger nut			+	+
<i>Dacryodes edulis</i> Lam	Burderaceae	African pear		Oruvbu	—	—
<i>Daucus carota</i> L.	Apiaceae	Carrot			+	+
<i>Dennettia tripetala</i> Bak. F.	Annonaceae	Pepper fruit		Ako	+	+
<i>Dialium guineense</i> Willd	Fabaceae	Velvet tamarind			+	+
<i>Dioscorea alata</i> Lour	Dioscoreaceae	Water yam		Igierua	+	+
<i>Dioscorea cayenensis</i> Lam.	Dioscoreaceae	Aerial yam		Ikpen	+	+

		Peri-urban market				Rural market			
Oba	Oregbene	Evbuotubu	Ugbogiobo	Ugbihioko	Iguobazuwa	Ehor	Usen	Ekiador	Ugbogui
+	+	+	+	+	+	+	+	+	+
+	+	+	-	-	-	-	+	+	-
+	+	+	+	+	+	+	+	+	+
+	+	+	+	+	+	+	+	+	+
+	+	+	+	+	+	+	+	+	+
+	-	+	+	-	+	+	+	+	+
+	+	+	+	+	+	+	+	+	+
+	+	+	-	-	-	-	-	+	+
+	+	+	+	+	+	+	+	+	+
+	-	+	+	+	+	+	-	-	-
-	-	+	+	+	+	-	+	+	+
+	+	+	-	+	-	-	-	-	-
+	-	-	-	-	+	-	+	-	-
+	+	+	+	+	+	+	+	+	+
+	+	+	+	-	-	-	-	-	-
+	+	+	+	+	+	+	+	+	+
+	+	+	+	+	+	+	+	+	+
+	+	+	+	+	+	+	+	+	+
+	+	+	+	-	-	-	+	+	-
+	+	+	+	+	+	+	+	+	+
+	+	+	+	+	+	+	+	+	+
+	+	+	+	+	+	+	+	+	+
+	+	+	+	+	+	+	+	+	+
+	+	+	+	+	+	+	+	+	+
+	+	+	+	+	+	+	+	+	+
+	+	+	+	+	+	+	+	+	+
+	+	-	+	+	+	+	-	-	-
+	+	+	+	+	+	+	+	+	+
+	+	+	+	-	-	-	-	+	-
+	+	+	+	-	-	+	-	-	-
+	+	-	-	+	-	-	-	-	-
+	+	+	-	-	-	+	-	-	+
+	+	-	-	-	-	-	-	-	-
-	-	-	+	+	+	+	+	+	-
+	+	+	+	+	+	-	-	+	-
-	+	-	+	+	-	+	+	-	+
+	+	-	+	+	+	-	-	-	-
+	+	+	+	+	+	+	+	+	+
+	+	+	+	+	+	+	+	+	+

(continued)

**Table 2** (continued)

Botanical name	Family	Common name	Form/product type	Local name (Bini)	Urban market	
					New Benin	Uselu
<i>Dioscorea rotundata</i> Poir	Dioscoreaceae	Yam	Yam chips and yam flour	Emowe	+	+
<i>Elaeis guineensis</i> Jacq	Palmae	Oil palm	Oil	Udin	+	+
<i>Garcina cola</i> Heckel	Guittiferae	Bitter cola		Edun	+	+
<i>Glycine max</i> L.	Fabaceae	Soy bean		Owerie-otan	+	+
<i>Gnetum africanum</i> Welw.	Gnetaceae				+	+
<i>Gossypium hirsutum</i> L.	Malvaceae	Cotton		Oruhu	+	+
<i>Hibiscus cannabinus</i> L.	Malvaceae				+	+
<i>Hibiscus sabdarifa</i> L.	Malvaceae	Roselle		Zobo	+	+
<i>Ipomea batata</i> L.	Convolvulaceae	Sweet potato		Iyinebo	+	+
<i>Irvingia gabonensis</i> Baill	Irvingiaceae	Bush mango		Ogwi	+	+
<i>Lycopersicum esculentum</i> L.	Solanaceae	Tomato	Tomato paste	Etomat-osi	+	+
<i>Mangifera indica</i> L.	Anacardiaceae	Mango		Emango	+	+
<i>Manihot esculatua</i> Crantz	Euphobiaceae	Cassava	Garri, fufu, bobozi and cassava flour	Igari	+	+
<i>Murraya koenigii</i> L.	Rutaceae	Curry		Curry leaf	+	+
<i>Musa paradisiaca</i> L.	Musaceae	Banana			+	+
<i>Musa sapientum</i> Linn	Musaceae	Plantain	Chips and plantain flour	Oghede	+	+
<i>Myristica fragrans</i> Houtt.	Myristicaceae	Nutmeg			+	+
<i>Ocimum gratissimum</i> Linn	Lasiotae	Scent leaf		Ebihiri	+	+
<i>Oryza sativa</i> L.	Poaceae	Rice		Izee	+	+
<i>Parkia clappertoniana</i> Key	Fabaceae	Locust bean		Evbarie	+	+
<i>Pennisetum glaucum</i> (L.) R. Br.	Poaceae	Millet	Kunu		+	+
<i>Pentaclethra macrophylla</i> L.	Fabaceae	African oil bean			+	+
<i>Persea americana</i> Miller	Lauraceae	Avocado Pear			+	+
<i>Phaseolus vulgaris</i> L.	Fabaceae	Beans	Beans cake, beans flour	Ere	+	+
<i>Phoenix dactylifera</i> L.	Palmae	Date palm			+	+
<i>Piper guineense</i> Schumach	Piperaceae	African pepper		Oziza	+	+
<i>Psidium guajava</i> L.	Myrtaceae	Guava			—	—
<i>Rauwolfia vomitoria</i> Afzel.	Apocynaceae	Rauwolfia		Akata	—	+
<i>Ricinus communis</i> L.	Euphorbiaceae	Castor oil			+	+
<i>Saccharum officinarum</i> L.	Solanaceae	Sugar cane	Sugar	Ukhure	+	+
<i>Sesamum orientale</i> L.	Pedaliaceae				+	+
<i>Solanum melogena</i> L.	Convolvulaceae	Garden-egg		Ekhue	+	+
<i>Solanum tuberosum</i> L.	Poaceae	Irish potato			+	+
<i>Sorghum bicolor</i> L.	Poaceae	Guinea corn	Kunu		+	+
<i>Spondias mombin</i> L.	Meliaceae	Hug phem		Okhikhan	—	+

		Peri-urban market				Rural market			
Oba	Oregbene	Evbuotubu	Ugbogiobo	Ugbiohioko	Iguobazuwa	Ehor	Usen	Ekiadoro	Ugbogui
+	+	+	+	+	+	+	+	+	+
+	+	+	+	+	+	+	+	+	+
+	+	+	+	-	+	-	+	-	+
+	+	+	+	+	+	+	+	+	+
+	+	+	-	-	+	+	+	-	+
+	+	+	+	+	+	+	+	-	+
+	-	-	-	-	-	+	-	+	-
+	+	+	+	+	-	-	+	-	+
+	+	+	+	+	+	+	+	+	+
+	+	+	+	+	+	+	+	+	+
+	+	+	+	+	+	+	+	+	+
+	+	+	+	+	+	+	+	+	+
+	+	+	+	+	+	+	+	+	+
+	+	+	+	+	+	+	+	+	+
+	+	+	+	+	+	+	+	+	+
+	+	+	+	+	+	+	+	+	+
+	+	+	+	+	+	+	+	+	+
+	+	+	-	+	-	-	-	-	-
+	+	+	+	+	+	+	+	+	+
+	+	+	+	+	+	+	+	+	+
+	+	+	+	+	+	+	+	+	+
+	+	-	-	-	-	-	-	-	-
+	+	-	-	-	+	+	-	+	-
+	+	+	+	+	-	-	-	-	-
+	+	-	-	-	-	+	+	+	+
+	-	-	-	-	-	-	-	-	-
+	+	+	-	+	+	-	-	-	+
+	+	+	+	+	-	-	-	-	-
+	+	+	+	+	+	+	+	+	+
+	+	+	-	+	-	-	-	-	-
+	-	-	-	-	-	-	-	-	-
+	+	+	+	+	-	-	-	-	-

(continued)

**Table 2** (continued)

Botanical name	Family	Common name	Form/product type	Local name (Bini)	Urban market	
					New Benin	Uselu
<i>Talfairia occidentalis</i> Hook	Cucurbitaceae	Pumpkin		Uvbeg-hen	+	+
<i>Talinum triangulare</i> Jacq	Portulacaceae	Water leaf		Ebodo-don	+	+
<i>Tamarindus indica</i> L.	Fabeaceae				+	+
<i>Tetrochidium didymostemon</i> (Baill.) Pax & K. Hoffm	Euphorbiaceae				–	–
<i>Thaumatococcus danielli</i> Benth.	Marantaceae			Ebe-eba	+	+
<i>Theobroma cacao</i> L.	Sterculiaceae	Cocoa		Koko	+	–
<i>Thymus vulgaris</i> L.	Lamiaceae	Thyme			+	+
<i>Treculia Africana</i> Decne.	Moraceae	African breadfruit			+	+
<i>Trilepisium madagascariensis</i> DC	Apocynaceae				+	+
<i>Triticum aestivum</i> L.	Poaceae	Bread (processed wheat)			+	+
<i>Vernonia amygdalina</i> Delile	Asteraceae	Bitter leaf		Oriwo	+	+
<i>Vigna unguiculata</i> L.	Fabaceae	Cow pea		Ere	+	+
<i>Vitellaria paradoxa</i> Gaertn	Sapotaceae	Shea butter			+	+
<i>Xylopia aethiopica</i> (Dunal) A. Rich	Lauraceae			Unie	–	–
<i>Zea mays</i> L.	Poaceae	Maize	Corn flour	Okha	+	+
<i>Zingiber officinale</i> Roscoe	Zingibeaceae	Ginger			+	+

+ = Present; – = Absent

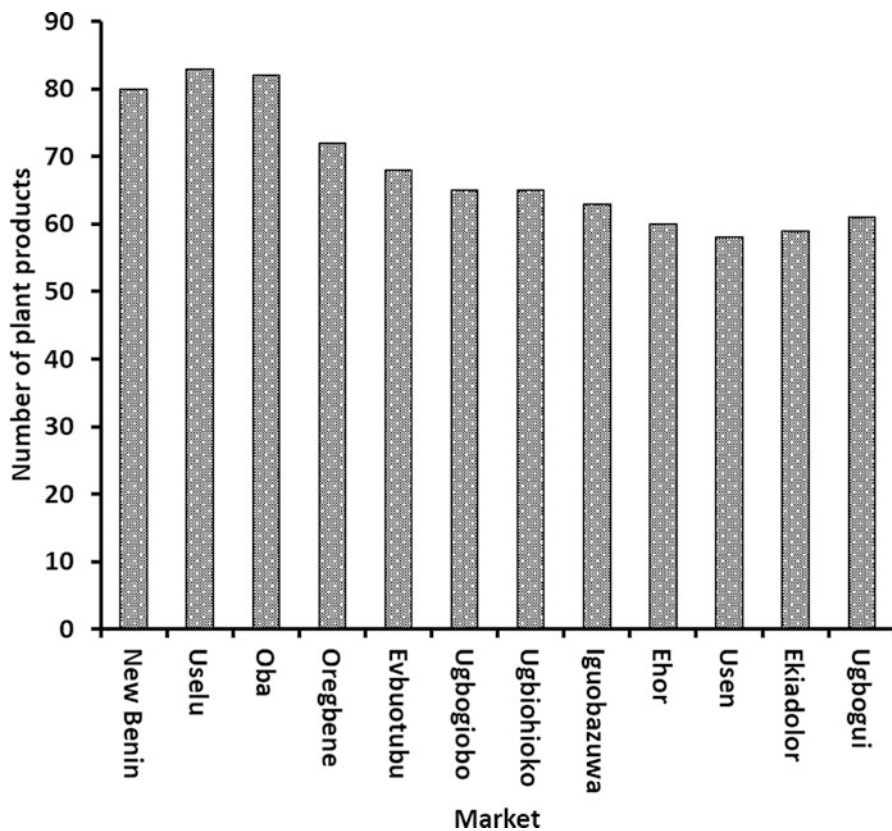




were more common in urban markets than in rural markets. On the other hand, *Tetrochidium didymostemon*, *Xylophia aethiopica*, *Anacardium occidentale*, *Bombax buonopozense*, and *Dacryodes edulis* were found mostly in rural markets. However, this trend might not translate directly into plant diversity in urban and rural centers but their utilization patterns. In Benin City, peri-urban markets mostly act as a transition zone for rural and urban markets. Previous investigations of rural markets in Nigeria by Johnson and Johnson (1976) recorded 58 species of plants sold in Nigeria, Keratela and Hussain (1990) reported 21 species, Gill et al. (1993) recorded 93 plants, Idu et al. (2010) reported 103 and Osawaru and Odin (2012) reported 117. The difference in the number of plants recorded from the different study might be related to the season when the study was undertaken as well as the agricultural yield of the previous seasons and change in attitude, taste, where vendors source their plants, prevailing economic and environmental conditions. Mekasha and Tirfe (2019) highlighted that the marketing of agricultural produce requires planned production, grading of products, transportation to markets, distribution, pricing, and advertisement. Most of the plant species found in the markets are exotic. This supports the report of Muhanji et al. (2011) and Ogwu et al. (2016, 2017) which opined that the colonial era introduced and promoted the production and sale of plants exotic to Africa. Overall, the plants and plant products distribution across the market ranged from 58 to 83 in all the markets assessed (Fig. 1). There are more plants and plant products in urban markets compared to peri-urban and rural markets. This might be due to the higher food demands of the growing urban population, urbanization policies, greater economic power, and migration (Romanik 2008; Ogwu 2019). If the current urbanization trend is left unchecked, it might increase the vulnerability of African cities to climate change as well as challenges associated with food security. Another reason for the high distribution of plant species in urban markets might be the large size of these markets and the age-long attitude of rural dwellers to bring their farm produce to city centers for sale. The least diversity was in Usen Market while Uselu Market had the highest species composition. Overall, the urban markets had higher species composition. Next to the urban markets were peri-urban markets in plant and plant product abundance.

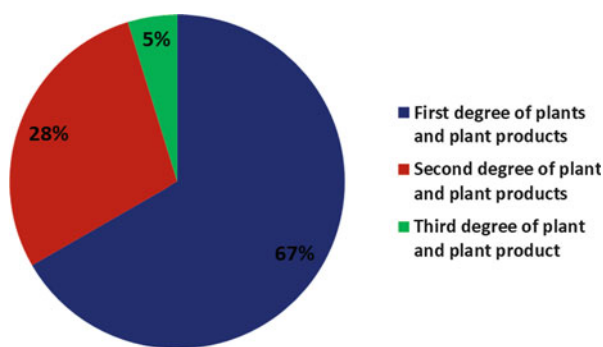
Plant products found in the different markets were assessed based on the level of processing that has been done to the plants. The classification of plant processing included first, second, and third-degree of plant and plant products (Fig. 2). The first degree of plant and plant products refers to the whole plant or plant part, while the second degree of plant and plant products and third degree of plant and plant products are processed and reprocessed plant or plant parts, respectively. It was also observed that most plant products were only processed once before been presented for sale in the markets (Fig. 2).

Plants and plant products in the local markets can be grouped into cereals (e.g., maize, rice, guinea corn, millet etc.), legumes (e.g., beans, groundnut, soybean etc.), stem tubers (e.g., yam and Irish potato), root tubers (e.g., cassava, carrot and sweet potato), fruits (e.g., pawpaw, orange, pineapple, mango, banana, pear, etc.), vegetables (e.g., waterleaf, bitter leaf, *Amaranthus* sp., *Celosia* sp., pumpkin leaf etc.), nuts (e.g., coconut), oil (e.g., palm fruit), spices (e.g., pepper, onion, ginger, garlic etc.).



**Fig. 1** Number of plants and plant products in local markets in Benin City and environs

**Fig. 2** Category of plants based on forms in which they are available in the market



The dominance of first degree processed plant products could be attributed to the near lack of government support for the agriculture sector of Nigeria. It also suggests Nigerians might prefer plant products that have undergone little to no processing. It

was observed that the availability of plants and their products rely on seasonal variations. The plants and plant products were seen in different forms in the markets depending on the season. Markets are made up 90–99% of plants and plant products. Some of these products may have been to the 3rd degree of processing, for example, Rain boot, etc. However, not all part of the plant may be essential. These forms are fruits, leaves, rhizomes, bulbs, corms, stem tuber, root tuber and also in processed forms such as fufu, gari, and cassava flour from cassava; oil, broom, and basket from oil palm; tomato paste from tomato, etc. These different forms are the status in which these plants and plant products are best sold and preserved. This is in line with the report of Idu et al. (2005).

The utilization pattern of the plants and plant products is presented in Table 3. Major categories included cereals, legumes, roots and tubers, fruits, fats and oils, sugar crops, fiber crops, spice and condiments, beverages, medicinal, and others. It was observed that 86% of the plants and plant products are used for foods, 10% are used for medicinal purpose while 3% is used for other purposes. However, the highest percentage was noticed in fruits, which are 35%.

The habit of plants found in local markets in Benin City and environs range from grasses, herbs, shrubs, and trees to vines. Overall, the composition was 39%, 20%, 17%, 15%, and 9% for trees, shrubs, grasses, herbs, and vines, respectively (Fig. 3). This is an indication that for plants and plant products gotten from tree crops, buyers, and vendors will have to wait for months or years before parts that are available to be harvested for sale or consumption.

The plant species recorded in the study are mainly used as a source of food, cash or medicine. Others supply diversity, essential nutrients, vitamins, or minerals in diets that would otherwise consist primarily of carbohydrates (Johns 2004; Johns and Sthapit 2004). Our investigation revealed that most of the plants and plant products are mainly for foods while a few are for medicinal and other uses. Often, they reflect cultural values and as a pool of health and nutritional information for the public and health practitioners (Johns and Eyzaguirre 2002). The availability of diverse plant and plant products in the market relies on local agriculture system, seasonal variations, local knowledge and practices, as well as plant germplasm. Produce are mainly sourced locally from home gardens and distant farms. Therefore, the vulnerability of agriculture systems in Benin City to climate change might not be affecting the production of the plants reported in this chapter in the short term. However, the interplay of diverse external factors and climate change is likely to affect the availability of plant and plant products currently found in open markets in the long term. It is recommended that the roles of women, soil health, and plant diversity be assessed in order to formulate a policy to mitigate and adapt to climate change impact on agriculture and food security in Benin City and other parts of Nigeria and Africa.

Moreover, considering that Muhanji et al. (2011) reported that there might be 45,000 plant species in Africa, the amount of plant and plant products recorded in open markets in Benin City only represent a small portion of that diversity. About 86% of the plants and plant products found in the markets in Benin City and environs are used for foods, 11% are for medicinal purpose, while 3% are used for others

**Table 3** Utilization pattern of plants and plant products in local markets within Benin City and environs

Botanical name	Common name	Cereal	Legumes	Root and tubers	Vegetables	Fruits and nuts	Fats and oil	Sugar crop	Fiber crop	Condiments and spices	Beverage and stimulant	Corn and rhizome	Medicinal	Other
<i>Abelmoshus esculentus</i>	Okra				•	•								
<i>Adenersonia digitata</i>	Baobab					•								
<i>Allium cepa</i>	Onion										•			
<i>Allium sativum</i>	Garlic										•		•	
<i>Amaranthus caudatus</i>	Spinach				•									
<i>Anacardium occidentale</i>	Cashew					•								
<i>Ananas comosus</i>	Pineapple					•								
<i>Annona muricata</i>	Sour sop					•								
<i>Arachis hypogaea</i>	Groundnut		•											
<i>Azadirachta indica</i>	Dogoyaro													
<i>Bombax buonopozense</i>						•								
<i>Brassica oleracea</i>	Cabbage				•									
<i>Calotropis procera</i>	Pepper					•								•
<i>Capsicum annum</i>	Pepper					•				•				
<i>Capsicum frutescens</i>	Pepper					•								
<i>Carica papaya</i>	Pawpaw					•								
<i>Celosia argentea</i>	Celosia				•									
<i>Citrus aurantifolia</i>	Lime					•							•	
<i>Citrus limon</i>	Lemon					•							•	
<i>Citrus sinensis</i>	Orange					•								

(continued)



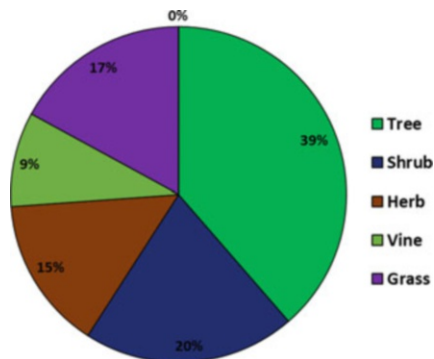








**Fig. 3** The habit of plants and plant products in local markets within Benin City and environs



purpose. Of the 86% used for food purpose, fruits and vegetable had the highest percentage of usage, which are 35% and 9% for fruits and vegetables, respectively. This is an indication that the markets in Benin City and environs have rich and diverse pool of fruits and vegetables, which are of great nutritional value. This is in line with the study of Odhav et al. (2007) and Ogwu et al. (2016) wherein they pointed out that indigenous vegetables and fruits represent inexpensive but high quality nutrition sources for the poor segment of the population. Since many indigenous food plants grow wild, they are accessible, they can be collected freely and are thus available to everyone, including the poor (Kabuye et al. 1999). Fruits and vegetables are of great nutritional value. They are important sources of vitamins and minerals that are essential for human health and well-being. Their consumption ensures the intake of various essential vitamins and mineral elements thus avoiding the problem of malnutrition (Yamaguchi 1983). There is a wide variety of indigenous vegetables and fruits found in Africa, which are chief sources of nutrients, vitamins, antioxidants, minerals, and proteins (Odhav et al. 2007; Ogwu et al. 2016; Ogwu 2020). Some of the indigenous vegetables and fruits are mainly used for medicinal purposes (Eifediyi et al. 2008).

Names and naming are important determinant factors in local society and contributing to promoting sustainable plant utilization and conservation (Penny 2001; Ogwu and Osawaru 2014; Ogwu et al. 2014). Plants are more easily recognized by their local names in every part of the world. These local names play a vital role in ethnobotanical study of a specific tribe or region (Singh 2008). The local names of crop plants, especially in Bini language, are reported among tribes surveyed. Documentation of local names is highly valued by Rogers (1963), Rogers and Applan (1973), Allem (2000), Bressan et al. (2005), Sawadogo et al. (2005), and Osawaru and Dania-Ogbe (2010). Local names are used to promote and trade plant and plant products in all the local markets assessed with little to no reference to their scientific nomenclature. Although local names are not directly recommended for scientific discussions because they lack uniformity and consistency (Singh 2008), yet they may certainly be considered as a useful tool for obtaining useful information on plants. Local names provide means of reference by local people in a particular

area. Also, in some cases, the plants are well known with their local name than the common names. This is the case of “ebolebo” and “dogoyaro” for Indian almond and neem, respectively.

In conclusion, plants provide valuable functions as foods, raw materials, socio-economic development, as well as sustainable environmental development and indicator of climate change impacts. They have been used as a means of livelihood sustenance and preservation of indigenous knowledge through their utilization pattern for centuries. This chapter established that local markets are a data bank for economic plant species. The diversity of these plants and plant products in the various local market assessed suggest that despite ongoing climate change, some level of plant production and plant-human interaction is ongoing. This chapter also revealed that urban markets have a higher number of plants and plant products compared to peri-urban and rural markets. This is a reflection that lesser populated markets are less diverse in terms of plants and plant products in the market. Additionally, majority of the plants and plant products are utilized as food with fruits being the predominant part that is used as food. Overall, the vendors/sellers are predominantly women and their interaction with plants in the market makes them an important group in the fight against climate change, food insecurity, and biodiversity crisis.

---

## References

- Agea GJ, Kimondo JM, Okia CK, Abohassan RAA, Obua J, Hall J, Teklehaimanot Z (2011) Contribution of wild and semi wild food plants to overall household diet in Bunyoro Kitara Kingdom. *Ugandan Agric J* 6(4):134–144
- Allem AC (2000) Ethnobotanical testimony on the ancestors of cassava (*Manihot esculenta* Crantz. subsp. *esculenta*). *Plant Genet Resour Newsl* 123:19–22
- Atedhor GO, Odjugo PAO, Uiriri AE (2011) Changing rainfall and anthropogenic-induced flooding: impacts and adaptation strategies in Benin City, Nigeria. *J Geogr Reg Plan* 4(1):42–52
- Bressan EA, Veasey EA, Peroni N, Felipim AP, Pacheo dos Santos KM (2005) Collecting yam (*Dioscorea* spp.) and sweet potato (*Ipomea batatas*) germplasm in traditional agriculture small-holding in the Vale do Riberira, Sao Paulo, Brazil. *Plant Genet Resour Newsl* 144:8–13
- Burkill RM (1985) The useful plants of tropical West Africa, vol 1. Royal Botanic Gardens, Kew. 635p
- Bye RA, Linares E (1983) The role of plants found in the Mexican markets and their importance in ethnobotanical studies. *J Ethnobiol* 3:1–13
- Cunningham AB (2001) Applied ethnobotany: people, wild plant use and conservation. People and plants conservation manual. Earthscan, London. 300p
- De Caluwe E (2011) Market chain analysis of baobab (*Adansonia digitata* L.) and tamarind (*Tamarindus indica* L.) products in Mali and Benin. PhD thesis, Faculty of Bioscience Engineering, Ghent University, Ghent
- Efe SI, Eyefia OA (2014) Urban warming in Benin City, Nigeria. *Atmos Clim Sci* 4:241–252
- Eifediyi K, Mensah JK, Ohaju-Obodo JO, Okoli RI (2008) Phytochemical, nutritional and medicinal properties of some leafy vegetables consumed by Edo people of Nigeria. *Afr J Biotechnol* 7:2304–2309
- Floyd AC, Oikpor R, Ekene B (2016) An assessment of climate change in Benin City, Edo State, Nigeria. *FUTY J Environ* 10(1):87–94

- Gill LS, Nyawuame HGK, Omoigui JD (1993) A survey of economic plants sold in the market of Benin City (Edo State) Nigeria. *Niger Technol Educ* 10:69–77
- Idu M, Osawaru ME, Orhue E (2005) Ethno-medicinal plant products in some local markets on Benin City, Nigeria. *Ethnobotany* 17:118–122
- Idu M, Erhabor JO, Efijuemue HM (2010) Documentation on medicinal plants sold in markets in Abeokuta, Nigeria. *Trop J Pharm Res* 9(2):110–118
- Johns T (2004) Underutilized species and new challenges in global health. *LEIZ Mag* 20(1):5–6
- Johns T, Eyzaguirre PB (2002) Nutrition and the environment. In: *Nutrition: a foundation for development*, vol 20. ACC/SCN, Geneva, pp 269–285
- Johns T, Sthapit BR (2004) Biocultural diversity in the sustainability of developing country food systems. *Food Nutr Bull* 25(2):143–155
- Johnson EJ, Johnson TJ (1976) Economic plants in a rural Nigerian market. *Econ Bot* 30:375–381
- Kabuye CHS, Maundu PM, Ngugi W (1999) Traditional food plants of Kenya. Kenya Resource Centre for Indigenous Knowledge, Nairobi
- Keratela YY, Hussain HSH (1990) Indigenous fruits sold in markets of Ishan area of Bendel State. *The Nigerian Field* 55:12–18
- Martin G (1992) Searching for plants in peasant marketplaces. In: Plotkin MJ, Famolare L (eds) *Sustainable harvest and marketing of rainforest products*. Island Press, Washington, DC, pp 212–223
- Mekasha J, Tirfe GG (2019) Assessing factors affecting marketing of vegetable products: the case of Qewet woreda, Ethiopia. *IOSR J Bus Manag* 21(4):82–93
- Muhanji G, Roothaert R, Webó C, Stanley M (2011) African indigenous vegetable enterprise and market access for small-scale farmers in East Africa. *Int J Agric Sustain* 9(1):194–202
- Nguyen MT (2005) Cultivated plant collections from marketplaces. *Ethnobot Res Appl* 3:5–15
- Obiri BD, Addai A (2007) People and plants: a survey of economic botanicals on the Kumasi central market. *Ghana J For* 21 and 22:50–71
- Odhav B, Beekrum S, Akula U, Baijnath H (2007) Preliminary assessment of nutritional value of traditional leafy vegetables in KwaZulu-Natal, South Africa. *J Food Compos Anal* 20:430–435
- Ogwu MC (2019) Towards sustainable development in Africa: the challenge of urbanization and climate change adaptation. In: Cobbinah PB, Addaney M (eds) *The geography of climate change adaptation in urban Africa*. Springer Nature, Cham. 29–55pp. [https://doi.org/10.1007/978-3-030-04873-0\\_2](https://doi.org/10.1007/978-3-030-04873-0_2)
- Ogwu MC (2020) Value of *Amaranthus* [L.] species in Nigeria. In: Waisundara V (ed) *Nutritional Value of Amaranth*. IntechOpen, London. 1–21pp. <https://doi.org/10.5772/intechopen.86990>
- Ogwu MC, Osawaru, ME (2014) Comparative Study of Microflora Population on the Phylloplane of Common Okra [*Abelmoschus esculentus* L. (Moench.)]. *Nigerian Journal of Biotechnology* 28:17–25
- Ogwu MC, Osawaru ME, Ahana CM (2014) Challenges in conserving and utilizing plant genetic resources (PGR). *Int J Genet Mol Biol* 6(2):16–22. <https://doi.org/10.5897/IJGMB2013.0083>
- Ogwu MC, Osawaru ME, Aiwansoba RO, Iroh RN (2016) Status and prospects of vegetables in Africa. In: Borokini IT, Babalola FD (eds) *Conference proceedings of the joint biodiversity conservation conference of Nigeria Tropical Biology Association and Nigeria Chapter of Society for Conservation Biology on MDGs to SDGs: toward sustainable biodiversity conservation in Nigeria*. University of Ilorin, Ilorin. 47–57pp
- Ogwu MC, Osawaru ME, Obahiagbon GE (2017) Ethnobotanical survey of medicinal plants used for traditional reproductive care by Usen people of Edo State, Nigeria. *Malaya J Biosci* 4(1):17–29
- Osawaru ME, Dania-Ogbe FM (2010) Ethnobotanical revelations and traditional uses of West African Okra [*Abelmoschus caillei* (A. Chev.) Stevels] among tribes in South-Western Nigeria. *Plant Arch* 10:211–217
- Osawaru ME, Odin EI (2012) An inventory of plants and plant products in rural and urban markets in some localities in Southern Edo State, Nigeria. *Univ Benin J Sci Technol* 1:1–13
- Osawaru ME, Ogwu MC (2014a) Conservation and utilization of plant genetic resources. In: Omokhafa K, Odewale J (eds) *Proceedings of 38th annual conference of The Genetics Society of Nigeria*. Empress Prints Nigeria Limited, Benin City, Nigeria, pp 105–119

- Osawaru ME, Ogwu MC (2014b) Ethnobotany and germplasm collection of two genera of cocoyam (*Colocasia* [Schott] and *Xanthosoma* [Schott], Araceae) in Edo State Nigeria. *Sci Technol Arts Res J* 3(3):23–28. <https://doi.org/10.4314/star.v3i3.4>
- Penny RA (2001) Gender and Indigenous knowledge experiences in Nigeria and the USA. *Indig Knowl Dev Monit* 9(1):16–17
- Rogers DJ (1963) Studies of *Manihotesculenta* Cranz and related species. *Bull Torrey Bot Club* 90:43–54
- Rogers DJ, Applan SG (1973) *Manihot and Manihotoides* (Euphorbiaceae), a computer assisted study, Flora Neotropica, monograph no 13. Hofner Press, New York
- Romanik C (2008) An urban-rural focus on food markets in Africa. Research report. The Urban Institute. 45p. <https://www.urban.org/sites/default/files/publication/31436/411604-An-Urban-Rural-Focus-on-Food-Markets-in-Africa.PDF>
- Sawadogo M, Duedraogo J, Belem Balma M, Dossou B, Jarvis D (2005) Influence of ecosystem component on cultural practices affecting the in situ conservation of agricultural biodiversity. *Plant Genet Resour Newsl* 141:19–25
- Singh H (2008) Importance of local names of some useful plants in ethnobotanical study. *Indian J Tradit Knowl* 7(2):365–370
- Whitaker TW, Cutler HC (1966) Food plants in a Mexican market. *Econ Bot* 20:6–16
- Yamaguchi M (1983) *World vegetables, principle, production and nutritive values*. Ellishorwood Limited Publishers, Chichester
- Yaradua SS, El-Ghani MA (2015) Ethnobotanical survey of edible plants sold in Katsina metropolis markets. *Int J Sci Res* 4:884–889

**Open Access** This chapter is licensed under the terms of the Creative Commons Attribution 4.0 International License (<http://creativecommons.org/licenses/by/4.0/>), which permits use, sharing, adaptation, distribution and reproduction in any medium or format, as long as you give appropriate credit to the original author(s) and the source, provide a link to the Creative Commons license and indicate if changes were made.

The images or other third party material in this chapter are included in the chapter's Creative Commons license, unless indicated otherwise in a credit line to the material. If material is not included in the chapter's Creative Commons license and your intended use is not permitted by statutory regulation or exceeds the permitted use, you will need to obtain permission directly from the copyright holder.





# Retooling Smallholder Farming Systems for Climate Change Resilience Across Botswana Arid Zones 19

Nnyaladzi Batisani, Flora Pule-Meulenberg, Utlwang Batlang, Federica Matteoli, and Nelson Tselaesele

## Contents

Introduction .....	340
Gantsi District and Bobirwa and Boteti Sub-Districts .....	344
Current Farming Systems in Gantsi District and Bobirwa and Boteti Sub-Districts of Botswana .....	345
Alternative Livelihoods in Gantsi District and Bobirwa and Boteti Sub-Districts .....	348
Indigenous Knowledge of Agricultural Practices in Gantsi District and Bobirwa and Boteti Sub-Districts .....	357
Potential Climate-Smart Agricultural Practices Identified by Farmers and Extension Workers .....	358
References .....	360

---

This chapter was previously published non-open access with exclusive rights reserved by the Publisher. It has been changed retrospectively to open access under a CC BY 4.0 license and the copyright holder is “The Author(s)”. For further details, please see the license information at the end of the chapter.

Disclaimer: The views expressed in this publication are those of the author(s) and do not necessarily reflect the views or policies of the Food and Agriculture Organization of the United Nations.

---

N. Batisani (✉)

Botswana Institute for Technology Research and Innovation, Gaborone, Botswana

Food and Agriculture Organization of the United Nations, Rome, Italy

F. Pule-Meulenberg · U. Batlang · N. Tselaesele

Botswana University of Agriculture and Natural Resources, Gaborone, Botswana

e-mail: [fpmeulenberg@buan.ac.bw](mailto:fpmeulenberg@buan.ac.bw); [ubatlang@buan.ac.bw](mailto:ubatlang@buan.ac.bw)

F. Matteoli

Food and Agriculture Organization of the United Nations, Rome, Italy

e-mail: [Federica.matteoli@fao.org](mailto:Federica.matteoli@fao.org)

© The Author(s) 2021

W. Leal Filho et al. (eds.), *African Handbook of Climate Change Adaptation*,

[https://doi.org/10.1007/978-3-030-45106-6\\_168](https://doi.org/10.1007/978-3-030-45106-6_168)

339

---

**Abstract**

**Background:** Scientific progress and developments in technology have improved our understanding of climate change and its potential impacts on smallholder farming systems in sub-Saharan Africa (SSA). The persistence of such smallholder farming systems, despite multiple exposures to climate hazards, demonstrates a capacity to respond or adapt. However, the scale and intensity of climate change impacts on smallholder farming systems in SSA will overwhelm any indigenous coping mechanisms developed over centuries. Therefore, there is need to co-develop resilient farming systems with farmers and extension workers in anticipation of the looming food security challenges in the midst of climate change.

A survey comprising of participatory rural appraisal, focus group discussions, participatory resource mapping, and SWOT analysis was carried out for the purposes of farming systems diagnosis in reference to their resilience to climate change in three districts cutting across dry arid zones of Botswana agricultural landscape. The survey also sought to identify vulnerability of the farming systems to climate change and subsequently co-develop with farmers and extension workers new climate proofed farming systems.

**Results:** Detailed evaluation of current systems and their strengths and weaknesses were identified. Farmers highlighted constraints to their production being mainly drought related but also lack of production inputs. These constraints are location and context specific as extension areas within a district highlighted different challenges and even different CSA practices for similar production constraints. Through participatory approaches, farmers were able to identify and rank potential climate-smart agriculture practices that could ameliorate their production challenges and subsequently developed implementation plans for these practices.

**Conclusions:** The study demonstrates that climate change is already having significant adverse impacts on smallholder farming systems and therefore, climate proofing these systems is necessary if livelihoods of smallholder farmers are to be sustained. Therefore, retrofitting current farming systems to be climate resilient is the first step to climate proofing smallholder farmers' livelihoods.

---

**Keywords**

Botswana · Farming systems · Adaptation strategies · Climate change · Smallholder farmers

---

**Introduction**

Agriculture is a proven path to prosperity as no region of the world has developed a diverse, modern economy without first establishing a successful foundation in agriculture. This trend is going to be critically true for Africa where, today, close to 70% of the population is involved in agriculture as smallholder farmers working

on parcels of land that are, on average, less than 2 hectares. As such, agriculture remains Africa's route for growing inclusive economies and creating decent jobs mainly for the youth. In Botswana, the agriculture economic sector is limited mainly to range resource-based livestock and pockets of arable farming based on rainfall and limited irrigated agriculture at several places (Alemaw et al. 2006). However, despite this aforementioned and the recent slowing in economic growth across much of the continent mainly due to the sharp drop in the global prices of oil and minerals, the prospects for African agriculture looks favorable. The African food market continues to grow with World Bank estimates showing that it will be worth US\$1 trillion by 2030 up from the current US\$300 billion (World Bank 2007, 2010). Demand for food is also projected to at least double by 2050. These trends, combined with the continent's food import bill, estimated at a staggering US\$30–50 billion, indicate that an opportunity exists for smallholder farmers – Africa's largest entrepreneurs by numbers – who already produce 80% of the food to finally transition their enterprises into thriving businesses (AGRA 2017). Botswana is a net food-importing developing country (NFIDC); thus there is an opportunity to increase domestic production of basic foodstuffs, particularly cereals (grain sorghum and maize) and pulses. The national demand for cereal stands at 200,000 t per year, of which only 17% is supplied through local production (GoB 2019). Therefore, investments in arable agriculture will stimulate private sector development, create employment, value-addition opportunities, and enhance food security and ultimately exports.

Climate change poses a challenge to the attainment of agricultural potential. Climate change is threatening to undo decades of agricultural development efforts in developing countries with scientific projections pointing to a warmer climate characterized by increases in both intensity and frequency of extreme climate events, particularly in sub-Saharan Africa. Nkemelang et al. (2018) observed an increase in extreme weather events such as heat waves and late and high spatial and temporal rainfall variability across Botswana. Therefore, although climate adaptation is a global requirement, the need for adaptation is considered higher among developing countries where vulnerability is presumably higher (Adger 2003) and also in the interest of individual farmers who rely on the revenue generated from agricultural production (Holzkämper 2017). The need for adaptation is especially true in Africa as the population is highly dependent on rainfed agriculture (the most climate-sensitive sector) and particularly for smallholder farmers as they generally have limited adaptive capacity (Morton 2007), hence considered among those who will suffer most from the impacts of climate change (Easterling et al. 2007). Mogomotsi et al. (2020) highlight the vulnerability of smallholder rainfed farmers to climate change and variability in Botswana. Smallholder agriculture has long been characterized by adaptive and flexible strategies to reduce vulnerability to climate natural variability and soil depletion (Adger et al. 2003; Tschakert 2007; Thomas et al. 2007; Eriksen et al. 2008). African farmers, particularly in dry land areas, have developed both on- and off-farm adaptation strategies in response to reoccurring droughts. Cooper et al. (2008) observed that coping better with current climatic variability in rainfed farming systems of sub-Saharan Africa is an essential



first step in adapting to future climate change, while Muyambo et al. (2017) highlight the role of indigenous knowledge in drought risk reduction.

Nevertheless, climate change is going to negatively affect smallholder farmers beyond their coping capacity for naturally-occurring droughts, hence the need to hybridize traditional drought coping mechanisms with technology through co-development of climate resilience farming systems involving farmers, extension workers, and agricultural experts. Hence the need to retool farmers and extension officers for climate. Williams et al. (2019) observed that smallholder systems heterogeneity requires local specific climate adaptation for reducing the negative impacts of changing climate in regions heavily relying on small farms agriculture.

Due to the instability of agricultural production as a result of complex, dynamic, and interrelated factors such as climate, markets, and public policy that are beyond farmers' control, there is a need for farmers to develop new farming systems that incorporate innovations in their objectives, organization, and practices adapted to changing production contexts (Martin et al. 2013). While Thornton et al. (2018) highlighted that the scale of change required to meet the sustainable development goals, including those of no poverty, zero hunger, and the urgent action needed to address climate change, will necessitate the transformation of local and global food systems. Thus the main aim of this chapter is to develop resilient farming systems in Gantsi District and Bobirwa and Boteti sub-districts of Botswana. The chapter is premised on the following specific objectives: to evaluate current farming systems in the three districts and identify climate-smart practices within each district; identify alternative livelihood options (off-farm) in the catchment areas; identify indigenous knowledge of agricultural practices (ethno-veterinary and ethno-botanical) to cope with effects of climate change and co-identify (farmers and extension workers); and recommend potential climate-smart agricultural practices. The Republic of Botswana is a landlocked country with an area of 582,000 km<sup>2</sup> (Fig. 1). The climate is semi-arid to arid with high spatial rainfall variability. Rainfall decreases and temperature range increases westward and southward, varying from 650 mm per annum in the east to 230 mm in the south-west.

Agriculture plays a significant role in the lives of rural communities where it provides food and income and employs a majority of the rural inhabitants. However, the Intergovernmental Panel on Climate Change (IPCC 2007) has identified the country as vulnerable to climate change and variability, probably due to its low adaptive capacity and sensitivity to many of the projected changes. Therefore, it implies that with climate change, including high temperatures and frequent droughts conditions for agriculture, will worsen. For example, models have predicted that parts of Botswana will become much drier and hotter (IPCC 2001). Currently, there are projected statistically significant decreases in mean rainfall and increases in dry-spell length at each global temperature level (Nkemelang et al. 2018). IPCC special report on global warming of 1.5°C underlined that areas in the south-western region, especially in South Africa and parts of Namibia and Botswana, are expected to experience the largest increases in temperature (Engelbrecht et al. 2015; Maure et al. 2018).

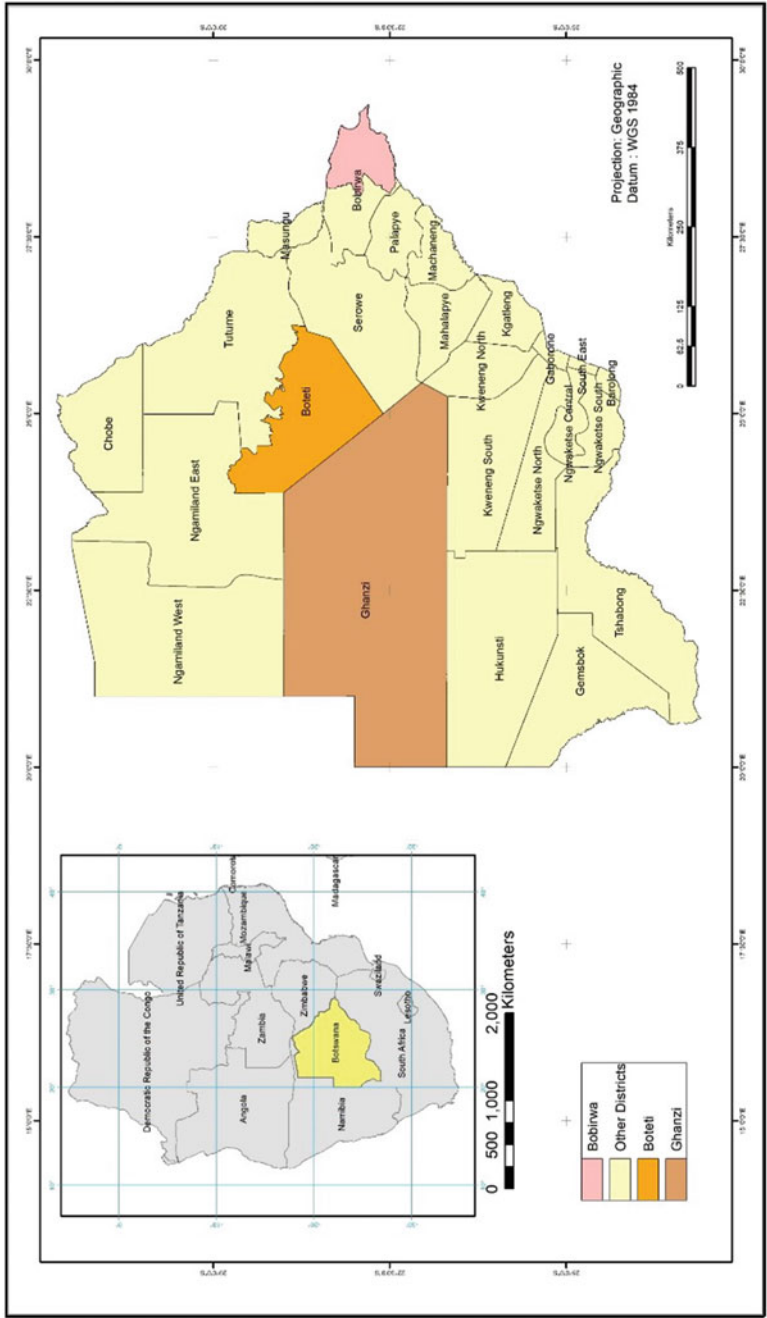


Fig. 1 Botswana location and the three study districts

## Gantsi District and Bobirwa and Boteti Sub-Districts

Although the three areas of interest are very similar in their vulnerability to climate change impact, they vary in terms of land area, population, and physiography. Gantsi District has mostly sandy, infertile soils with low water holding capacity. Farming is the dominant economic activity in the district with pastoral being most dominant although of recent there has been an increase in irrigated agriculture. Bobirwa sub-district has relatively fertile soils although some. Integrated pastoral and arable rainfed farming are major activities in the district. Boteti sub-district practices both arable and pastoral farming.

A farming system model by Collinson (1987) was used to aid with farming systems diagnosis of the three districts (Fig. 2). In the model, there are visible and observable aspects, which are represented by solid boxes, and those that are deduced from the description of these aspects and verified by a discussion with farmers and extension officers, represented by perforated boxes.

Information on current farming systems in each district was acquired through key informants, farmers, and extension workers. Two extension areas were randomly selected in each district.

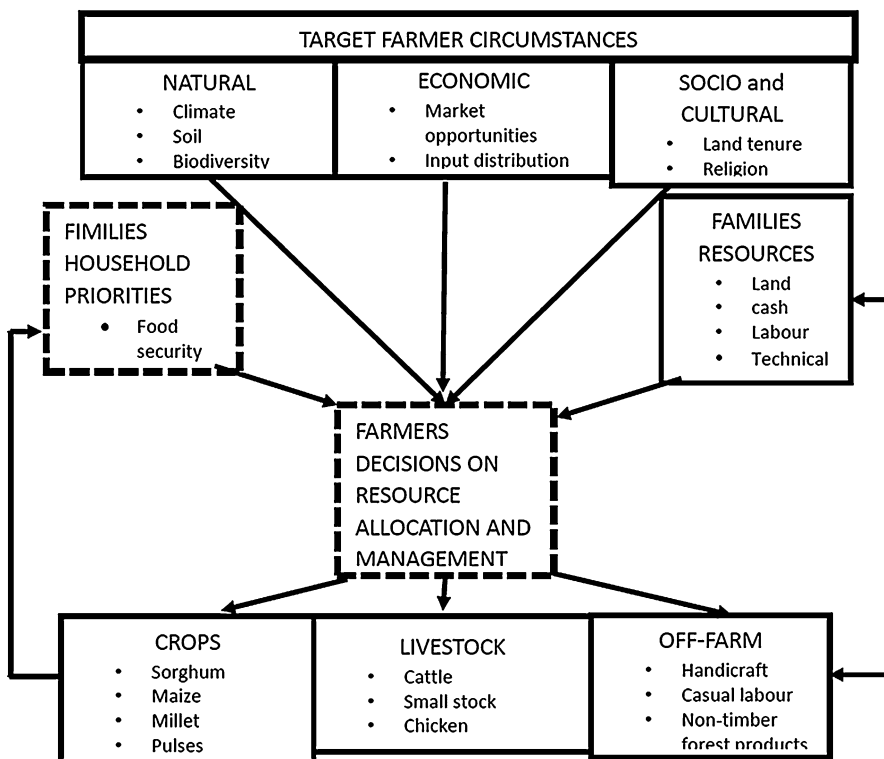


Fig. 2 Farming system diagnosis by Collinson (1987)

- (i) Gantsi District (Charles Hill, Ncojane)
- (ii) Boteti sub-district (Mosu, Moremaoto)
- (iii) Bobirwa sub-district (Bobonong, Gobojango)

Multistage sampling technique was used to determine the ideal sample size of participants in the focus group discussion (FGD) using Krecjie and Morgan (1970) formula. The multistage sampling process was conducted with the assistance of extension areas workers who provided facilitators with the number of active farmers in their catchment. Triangulation was applied where specific information was needed. A SWOT analysis was used to evaluate current farming systems, their strengths (resilient to climate change and droughts), and weakness (vulnerability to climate change and droughts).

The sharing of ideas (experience) among farmers and extension workers allowed them to evaluate the shared experience and seek more solutions to the prevailing livestock and crop production challenges and CSA practices in their respective extension areas. The list of proposed CSA options was discussed with participating farmers to ensure a common understanding was reached between them, facilitators and extension workers. During the discussion, farmers were encouraged to come up with additional practices especially those relating to indigenous knowledge practices (ethno-botanical and veterinary practices). At the end, ranking of the proposed CSA practices was done according to Khatri-Chhetri et al. (2017).

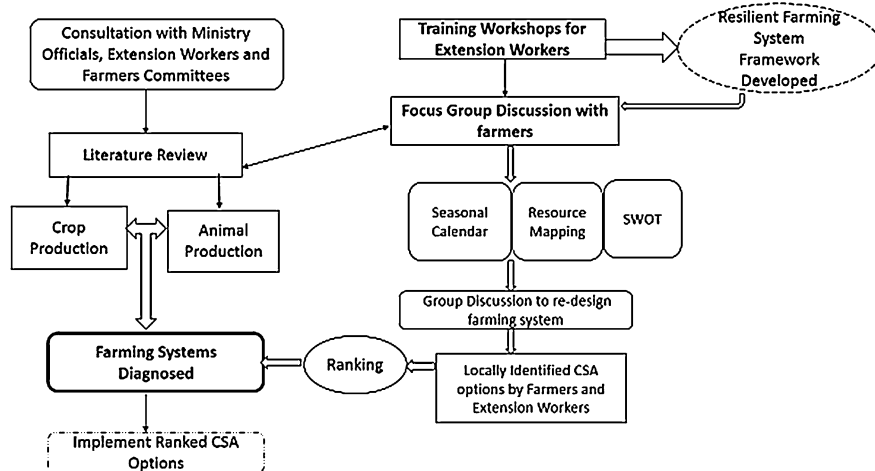
The discussion of the predetermined options was designed into a participatory action plan that addressed the resources needed for implementation of the ranked CSA potential practices. The action plan and the developed activity plan was a step-by-step process that helped these groups of farmers together with their extension workers and facilitators to design and deliver solutions to address proposed climate-smart agricultural practices. Farmers ranked potential CSA practices for developing climate-resilient farming systems and together with extension workers developed their implementation guidelines. Figure 3 is a summary of the methods that were used to collect data needed to co-develop climate-smart resilient farming systems across the study areas.

Facilitators used a stated preference method to analyze the farmers' preference of CSA practices. In the stated preference method, participating farmers were asked about their preferences in a list of practices (Khatri-Chhetri et al. 2017).

---

## **Current Farming Systems in Gantsi District and Bobirwa and Boteti Sub-Districts of Botswana**

Table 1 displays CSA practices currently found in the three districts. Such practices can be divided into crop and livestock related. Crop technologies that were common to all areas included fodder production and intercropping, whereas disease control and public health as well as ethno-veterinary practices were the only two livestock practices that cut across the three districts. Fodder production included planting of cowpea, lablab, maize, melons, forage sorghum, napier grass, and soybean. Cowpea



**Fig. 3** Flow of methods used in developing the farming systems

and maize were not specifically planted as fodder, but their stover is normally fed to livestock after harvesting. Intercropping involves planting of rows of cereals such as maize, sorghum, and millet alternating with legumes such as cowpeas, lablab, and soybean and is part of integrated pest management as it provides conducive environment for natural enemies (Obopile et al. 2018) and also in maintaining soil fertility through biological nitrogen fixation (Pule-Meulenberg et al. 2018).

Current farming systems in Gantsi District is predominantly livestock farming as observed from the large number of cattle posts (livestock holdings) (Fig. 4). The rearing system is free ranging based on rainfed natural pastures. This resource (natural pastures) is prone to droughts and overgrazing leading to a large number of livestock mortalities.

As an adaptation move, farmers are moving toward some integrated crop-livestock systems with production of fodder crops, while some large commercial cattle ranchers use parts of their farms for diversifying into vegetable production. Small-holder farmers are also practicing small-scale irrigated gardens. Maize and cowpeas are the main rainfed arable crops in the area, and because of low drought tolerant of maize, yields are low in most years (Fig. 5). Minimum tillage is practiced and pioneered as a conservation agriculture (CA) in the district. However, due to the sandy nature of the soil, farmers complained of the disappearance of planting pits/basins, making their construction a laborious task that has to be repeated every year.

Boteti sub-district just like Gantsi District is a predominantly cattle-rearing area although has more rainfed arable farming. Figure 6 shows the spatial distribution of land uses in the sub-district. The main crops grown are maize, cowpeas, sorghum, and millet; the latter two being drought-tolerant crops, whose limitation is susceptibility to bird damage. Of recent, crop damage by wildlife especially elephants have increased in the sub-district.

**Table 1** CSA practices currently found in the Gantsi District and Bobirwa and Boteti sub-districts

Current CSA practices	CSA details	Gantsi District	Bobirwa Sub District	Boteti Sub District
Planting in tires	Vegetables	x		
Irrigation	Combination of different types of vegetables	x		
Holistic livestock management	Planned grazing in fenced farm	x		
Fodder production	Cowpea, lablab, Maize, Melons, Forage sorghum, sugar cane, soya	x	x	x
Intercropping	Intercropping legumes and cereals	x	x	x
Crop rotation	Cereals rotated with legumes	x		x
Backyard gardening	Different types of vegetables	x		
Integrated farming	Combination of different crop enterprises	x		
Integrated farming	Combination of different types of livestock, fodder, vegetables, field crops, and poultry	x		
Supplemental feeding	Using commercial and fodder	x	x	
Disease control and public health	Construction pit latrines to curb the spread of beef measles	x	x	x
Poultry production	Constructed poultry houses which control temperatures using natural ventilation. Collection of chicken manure to sell for vegetation production		x	
Small stock production	Apply recommended management practices that follow small stock calendar		x	x
Production of marula oil cake	Marula by products used for animal feeds		x	
Utilization of indigenous tree species for livestock feeding	Cutting <i>Vachellia</i> spp. ( <i>Vachellia tortilis</i> and <i>V. erioloba</i> ) species and mixing with stover to make livestock feeds		x	
Pigs production	About 300 individual pigs housed in large paddocks		x	
Minimum tillage (ripping using tractor)	Mainly cowpeas, watermelons, maize, sorghum			x
Minimum tillage (ripping using donkeys)	Cowpeas, watermelons, maize, sorghum			x
Planting pits/basins	Cowpeas, watermelons, maize melons, maize	x		x
Cover cropping	Mainly cowpeas, pumpkins, lablab, watermelons, melons		x	x
Fertilizer application as per soil analysis	Use of fertilizers on sorghum, maize			x

(continued)

**Table 1** (continued)

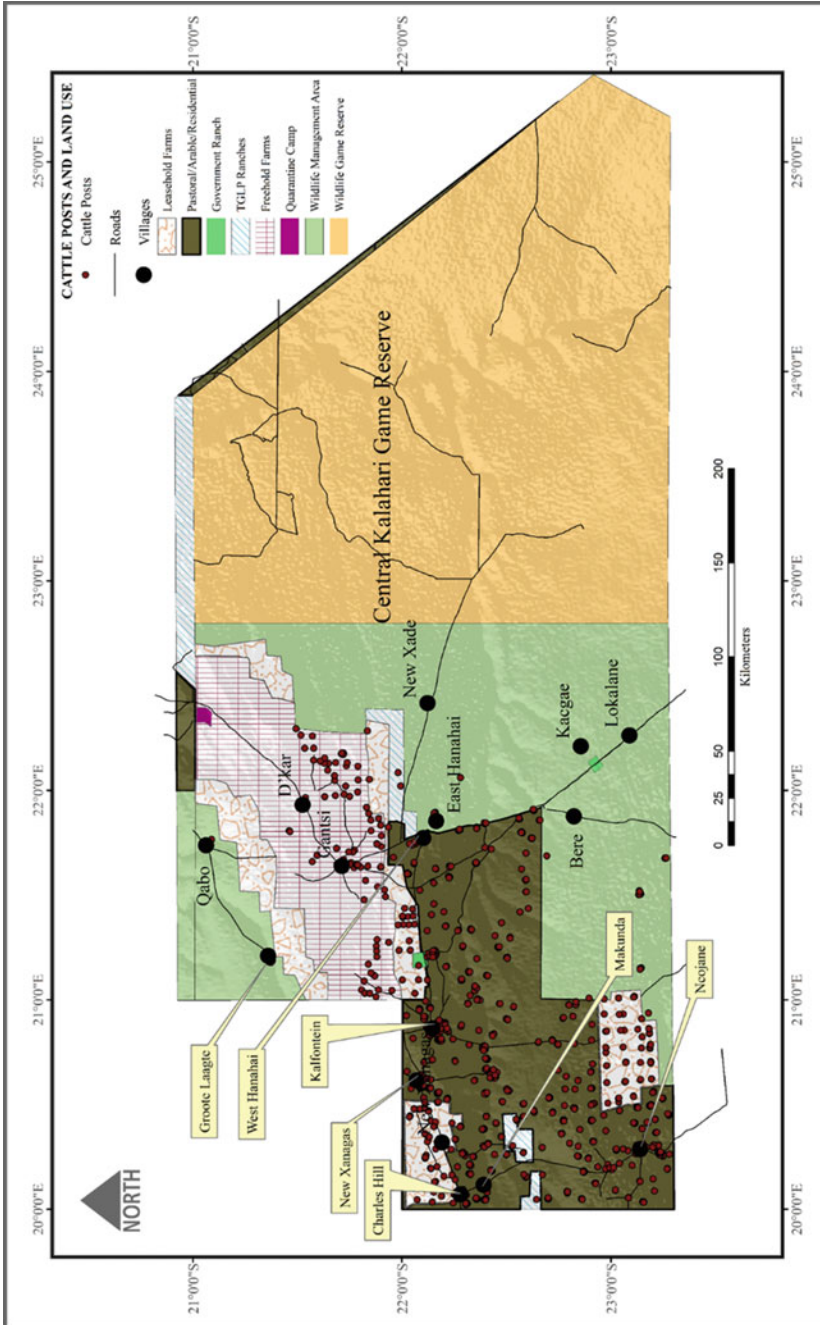
Current CSA practices	CSA details	Gantsi District	Bobirwa Sub District	Boteti Sub District
Kraal manure application	Application of kraal manure on maize			x
Provision of housing	Housing for goats' kids			x
Vaccinations	Vaccinate against livestock and poultry diseases	x	x	x
Use of solar energy	Solar panels to generate electricity			x
Ethno veterinary practices	Examples: wood ash for retained placenta; powdered dead/sun bleached millipede skeleton to treat eye infection	x	x	x
Use of tolerant breeds	Use of Tswana goats, Boer goats			x

Figure 7 displays current farming systems for crops and livestock in Letlhakane extension area of Boteti sub-district. In order to minimize drought impacts on both livestock and crops, it is imperative to increase the number of people that practice climate-smart agriculture technologies such as conservation agriculture, fodder production, and the use of drought-tolerant germplasm.

Of the three districts, in terms of both physiography and farming systems, Boteti lies at the transitional zone between Gantsi and Bobirwa in having some aspects of sandy predominant in Gantsi but also having the more fine-textured fertile soils found in Bobirwa. Similar to Gantsi District, livestock production is dominant in the Boteti sub-district. In Boteti sub-district, rainfed arable agriculture comprising sorghum, millet, maize, and cowpeas are among the major crops grown similar to Bobirwa.

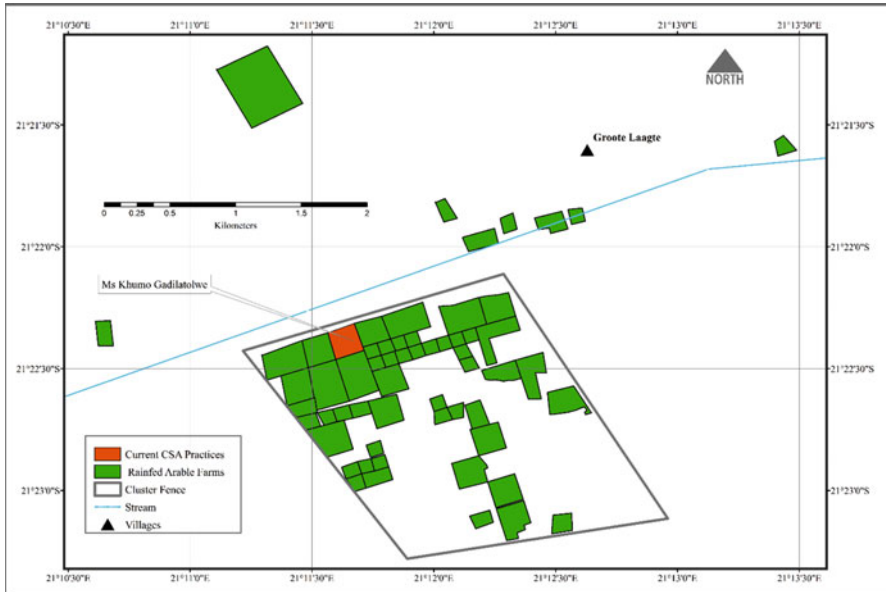
## Alternative Livelihoods in Gantsi District and Bobirwa and Boteti Sub-Districts

Table 2 shows alternative livelihoods outside the agricultural sector. It is evident that Gantsi District had many more alternative livelihood activities compared to the two sub-districts of Bobirwa and Boteti. This is probably due to the fact that Gantsi township is more urban compared to the villages of Bobonong and Letlhakane, which are the sub-district headquarters for Bobirwa and Boteti sub-district, respectively. In each of the three study areas, livelihood activities were varied as shown in Table 2. The common activities that cut across the three districts included employment through the Ipelegeng program (a Government of Botswana poverty alleviation scheme), sale of veld product, running of tuckshops, domestic work (being a maid), taxi services, sale of traditional brews, and catering services.

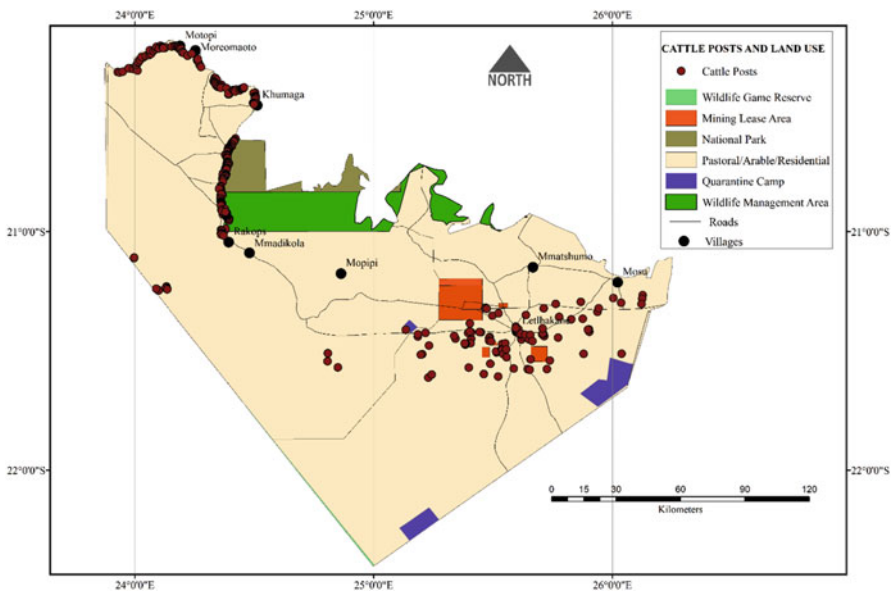


**Fig. 4** Spatial distribution of current farming systems in Gantsi District

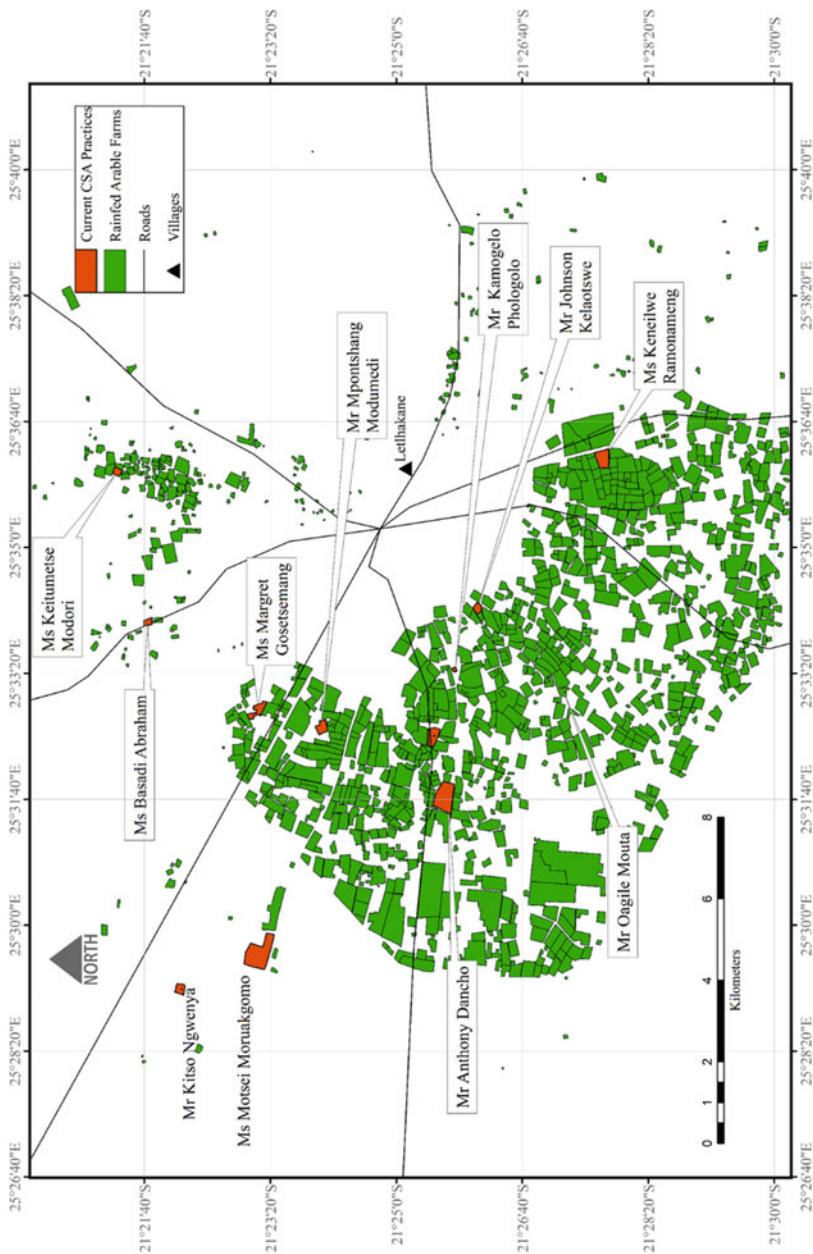




**Fig. 5** Current farming systems for crops and livestock in Grootte Laagte extension area (Gantsi)



**Fig. 6** Spatial distribution of current farming systems in Boteti district



**Fig. 7** Current farming systems for crops and livestock in Lethlakane extension area (Boteti)

**Table 2** Alternative livelihoods for Gantsi District and Bobirwa and Boteti Sub-Districts

Alternative livelihoods	Gantsi District	Bobirwa sub-district	Boteti sub-district
Employed in Ipelegeng projects	x	x	x
Traditional herbalists selling traditional medicines	x	x	
Selling of veld products	x	x	x
Provision of mechanical services mainly in Gantsi township	x		
Renting out houses	x		
Performing arts	x		x
Sale of traditional brews in shebeens	x		
Micro-enterprises (tuckshop)	x	x	x
Sales agents	x		
Farm work (livestock herding)	x		
Horse racing (jockeys)	x		
Dog racing	x		
Domestic work	x	x	x
Mobile safari	x		
Sale of game meat from community trusts	x		
Taxi services	x	x	x
Hired donkey carts for transport	x		
Game farming	x		
Handicrafts	x	x	x
Traditional brews	x	x	x
Labor for destumping arable fields	x		
Illicit substances (marijuana)	x		
Provision of transport for goods	x		
Cattle sales agent	x		
Brick molding	x		x
Poaching and hunting	x		

Bakery		x		
Dependency on male/female partners		x		
Garbage collection		x		
Fishing			x	x
Harvesting wood, grass and poles			x	x
Catering services		x		x
Sewing (tailoring)			x	x
Pottery				x
Thatching			x	x
Food processing				x
Sale of secondhand clothes			x	x
Sale of ornamental and fruit trees			x	
Sale of semi-precious stones			x	
Using recycled paper to make flower pots			x	
Sale of empty cans			x	
Recycling old tires to make livestock troughs			x	
Leatherworks			x	
Hair salons				
Wood carving			x	x
Destumping to increase hectareage in fields			x	
Panel beating and motor mechanic			x	
Pottery				x
Welding				x
Upholstering				x

The types of veld products sold are area specific although there are some common ones. For example, they include the morama bean (*Tylosema esculentum*), mongoose seed (*Bauhinia petersiana*), and wild berries such as *Grewia flava*. In Bobirwa, some of the veld products being sold are the mopane worm (*Imbrasia belina*), fruit of baobab (*Adansonia digitata*) tree, marula (*Sclerocarya birrea*) fruits, monkey orange, *Grewia flava* berries, *Vangueria infausta* fruits, *Mimops zeyheri*, and wild vegetables such as *Cleome gynandra*, *Amaranthus* spp., and wild okra. For the Boteti sub-district, veld products include the harvesting of the water lily which is as a condiment for meat and sale of indigenous vegetables as described for Bobirwa and wild fruits as baobab (*Adansonia digitata*) and marula (*Sclerocarya birrea*). The sale of firewood and handicrafts was also common among the study areas, the difference being the type of species that is being sold.

It is noteworthy that veld products are dependent on climate because during prolonged droughts when crops fail and livestock die, wild plants are equally affected; hence such products go off the markets. This situation is also true for traditional brews that are either made from mainly sorghum or wild fruits. During drought years, they would also not be available. This scenario shows the extent to which smallholder farmers are exposed to the effects of climate change, hence the need to adopt climate-smart technologies, on and off farm.

The recurring droughts leading to asset losses have driven communities in these three districts to develop some alternative livelihoods strategies for coping with drought challenges. Nevertheless, these alternative livelihoods strategies developed to cope with natural droughts are unlikely to match the severity and frequency of climate change-induced droughts because of their short-term nature (Table 2), hence the need for coming up with CSA technologies by Government and other stakeholders. However, the adoption of these CSA technologies has not been promising due to among other obstacles, weaknesses as highlighted in Table 3. These weaknesses or malalignment of the current CSA technologies used in the districts or their implementation may be due to that they were never meant for farming systems and cultures found in the three districts, therefore could have been adapted for these systems before implementation. Mwongera et al. (2017) noted that approaches that aim to identify and prioritize locally appropriate climate-smart agriculture technologies will need to address the context-specific multidimensional complexity in agricultural systems.

Therefore, to improve the adoption of CSA technologies, there is need for co-development of technologies with farmers and extension workers at the local level. Through participatory approaches, farmers ranked various CSA interventions. The examples in Table 4 below shows that preferences vary at local extension levels within a district and also between districts, highlighting the importance of considering local context and dynamics of farming systems when designing CSA practices and interventions (Tables 4–9). Khatri-Chhetri et al. (2017) noted that farmers' priorities for CSA technologies are linked with prevailing climatic condition of particular location, socio-economic characteristics of farmers, and their willingness to pay for available technologies.

**Table 3** SWOT analysis of current CSA farming practices in Gantsi District and Bobirwa and Boteti sub-districts

<b>Strengths</b>	<b>Weaknesses</b>
Improved soil fertility	Use of hybrid seed destroyed traditional crop varieties
Technologies are adaptable to climate change	Destruction of CSA crop structures by wind erosion and livestock
High carbon sequestration	Unavailability of equipment for CSA crop practices
Improved food and nutrition security	The decision to sell livestock is predominantly done by males
Both males and females participate in farming activities	The decision to sell crops is predominantly done by females
Availability of underground water	Shortage of livestock grazing land and grazing resources
Availability of arable land	Poor vegetation
Supportive Government policies	Shortage of farming equipment
Mild winters	Lack of farm input suppliers
Availability of veldt products (natural resources)	Poor roads and infrastructure
Fertile soils	Lack of research and development (e.g., abattoirs)
Moisture conservation	Long-time taken by Land Board to allocate land
Pest and weeds control (break life cycle)	Shortage of labor
Reduction of soil erosion	Very interested to do fish farming
	No financial assistance for fisheries
	Few trained officers in Aquaculture
	Unreliable rainfall
	Reliability on Government hand out
	Conflict on Government policies
	Unwillingness to change by farmers to new technologies
	High farmers to extension worker ratio
	Lack of documentation on fish farming in Botswana
	Blanket application of fertilizers
<b>Opportunities</b>	<b>Threats</b>
Adaptation with co-benefits	Occurrence of extreme weather conditions (e.g., change of start of rainy season)
Resilience to drought due to irrigation	Emergence of new pests and diseases
Diversified crop production	Introduction of alien grass species in the rangelands (e.g., <i>Cenchrus biflorus</i> )
Employment creation	Competition of labor with Government programs
High demand for fish	Other farmers may not cooperate in rotational grazing and correct stocking rate in communal areas
Commodity clusters of farmers can be helping in farming systems (e.g., poultry and dairy)	Human-wildlife conflict (elephants)
Agro-tourism	To develop small stock slaughtering facility
Diversification in farming	Human-wildlife conflicts
Fish has a potential to grow since it is a new in Bobirwa sub-district and has a high nutritional value	The rain pattern has changed
Enhanced import substitution	Heat waves
Availability of sunlight for usage of solar power	Lack of raw materials for feeds
No Market for cattle to BMC because Bobirwa Sub District is not a green zone	Use of hybrids seeds
Irrigation (crops, fodder production) almost the whole year	Use of exotic livestock and poultry breeds
Multiplication of Musi breed	Lack of buy in by the Government on the programs for fisheries (just like LMID)
Improved soil fertility (legumes)	High budget to start fish projects
	Invasive species
	Stock theft from the neighboring countries
	Aging farmers
	Conversion of arable land to other land uses (e.g., tourism and settlements)
	Contamination of environment

**Table 4** Indigenous (ethno-veterinary) practices in the Gantsi, Bobirwa, and Boteti

Practices	Gantsi District	Bobirwa Sub District	Boteti Sub District
Use of charcoal for diarrhea in calves			x
Use of charcoal for dressing livestock wounds		x	
Use of charcoal to treat poisoning in dogs		x	
Use mix of dry donkey dung, salt, and wood ash and administered orally for retained placenta in small stock			x
Use of <i>Senna italica</i> (sebete) for the treatment of calf paratyphoid	x	x	x
<i>Ximenia</i> spp. for the treatment of foot rot in livestock			x
Use of sugar to treat visually impaired eyes and eye branding	x	x	x
Bandaging a fracture with wood and soft cloth		x	x
Use of <i>Aloe</i> spp. (mokgwapha) for foot rot			x
Use of wood ashes mix for snake bites			x
Use of cow dung after branding or dehorning			x
<i>Thamnosma rhodesica</i> (moralala) for prevention of miscarriage and still birth		x	x
<i>Diospyros lycioides</i> (letlhajwa) for control of <i>Pasteurella</i>			x
Use of <i>Aloe</i> spp. (mokgwapha) in birds against Newcastle disease and coccidiosis	x	x	x
Use of “thobega” against fractures in livestock		x	x
Dry old bleached millipede is crushed and applied to treat visually impaired eyes	x	x	x
Use of sugar to treat visually impaired eyes	x	x	x
Use of <i>Ziziphus mucronata</i> leaves to treat eye infections			x
<i>Ziziphus mucronata</i> pounded leaves and paste applied to dress wounds	x		
Use of wood ash mainly <i>Combretum imberbe</i> (Motswere tree) to control external parasites in chicken and puppies		x	x
Use of burnt cow dung against mosquitoes			x
Use of wild cucumber (mokapane) for the treatment of wounds			x
Use of dried cow dung smoke for the treatment of mastitis; burning cow dung is placed under the udder of the animal for the smoke to cover the udder			x
A string is tied on the warts and left until it falls off			x
Ash of <i>Vachellia mellifera</i> is mixed with water and administered orally when an animal has retained placenta; can also be used to control weevils in grain	x		x
Use of hot ring iron to treat eye infection			x
Cutting of tail and ears for treatment of animals against <i>Pasteurella</i>		x	x
Liquid paraffin external parasites on chicken, cats, dogs, and rabbits		x	

(continued)

**Table 4** (continued)

Practices	Gantsi District	Bobirwa Sub District	Boteti Sub District
Potassium per manganite to control chicken diseases (e. g., coccidiosis)		x	
Use of brake fluid to control mites	x	x	
Use of bitter apple fruits (thontholwana/morolana) to treat eye infection		x	
Use of charcoal to treat poisoning in dogs		x	
Use of sugar for control of uterine prolapse	x		
Use of purslane to control uterine prolapse	x		

### Indigenous Knowledge of Agricultural Practices in Gantsi District and Bobirwa and Boteti Sub-Districts

Farmers across the three districts indicated that they had indigenous agricultural practices pertaining to production of livestock and crops (Tables 4 and 5). Table 4 shows ethno-veterinary practices across the three districts. A number of practices such as the use of *Senna italica* to treat calf paratyphoid, treatment of eye infection in livestock using sugar and/or branding around the infected eye, treatment of poultry diseases such as Newcastle and coccidiosis using *Aloe* spp., and the use of dried up and bleached millipede carcass for eye infections in livestock were found in all the study areas. It is noteworthy that about a third of the practices are plant based. Consequently, prolonged droughts caused by climate change will affect them, hence the need to intentionally conserve wild plants. Other practices are based on plant products such as charcoal, wood ash, and smoke.

Table 5 displays the ethno-botanical practices found in the three districts. The use of a mixture of tobacco, chillis, garlic, onions, and soap or a combination of any two with liquid soap is common among the three districts for the control of aphids (*Aphis craccivora*), red spider mites (*Tetranychus urticae*), and fungi. The digging of trenches around arable fields for control against corn cricket (*Acanthopplus discoidalis*) and the traditional magical powers to protect fields against pest were common in the Gantsi District and Bobirwa sub-districts. The use of chilli blocks to scare away elephants where crushed chillis and mixed with cow dung, dried, and burnt was practiced in the Bobirwa and Boteti sub-districts. Much like with indigenous practices for livestock, about a third of the practices are plant based. Other practices such as digging of trenches to control corn cricket, animal snares, scare crows, use of reflectors to scare away elephants, and other can be referred to as physical.

It is interesting that out of the list of indigenous practices for both crops and livestock, none deal directly with increasing production but are all for the protection of pests and diseases. Furthermore, many of the practices are plant based and therefore are equally affected by the harsh effects of climate change.



**Table 5** Indigenous (ethno-botanical) practices for crops in Gantsi District and Bobirwa and Boteti sub-districts

Practices	Gantsi District	Bobirwa Sub District	Boteti Sub District
Use of wood ash for pest control			x
Mixture of tobacco garlic and onion and sunlight for aphid control	x	x	x
Trenches for control of <i>Acanthopplus discoidalis</i> (setotojane)			x
Use of scare crows			x
Foot crushing of grasshoppers			
Animal traps (snares)			
Use of sugar to attract natural enemies			x
Application of <i>Combretum imberbe</i> and <i>Vachellia mellifera</i> (motswere and mongana wood ash, respectively, around plant stems and also application in seeds/grains to protect against storage pests			x
Use of chilli block, where chillis are mixed with cow dung, then dried, and then burnt to deter elephants		x	x
Python fat is mixed with seed before planting to protect the arable fields from predators		x	
Burn mohetola ( <i>Indigofera</i> sp.) to accelerate sorghum maturity		x	
Use of empty containers to scare the birds and elephants		x	
Use of metal reflectors along the fence to scare the elephants		x	
Collect human urine and pour small bits of it on strategic places around the perimeter fence to scare kudus and jackals (mark territory)		x	
Filling a clear bottle with water and placing at strategic places to scare away jackals		x	
Digging a trench around the field to control pests, e.g., corn cricket	x	x	
Magically protect (Go upa masimo) through seeds	x	x	
Use of whey to control aphids	x		
Eucalyptus for the control of weevils in grains	x		

## Potential Climate-Smart Agricultural Practices Identified by Farmers and Extension Workers

When designing CSA implementation strategies at farm level, one must consider adaptation options that are well evaluated and prioritized by local farmers in relation to prominent climatic risks in that location (Khatri-Chhetri et al. (2017); FAO 2012). Table 6 is a compilation of how farmers in the three districts ranked CSA practices according to their preferences. At each district, at extension area

**Table 6** Ranking of CSA practices in the Gantsi District and Bobirwa and Boteti sub-districts

No.	CSA Intervention	Ghanzi		Bobirwa		Boteti	
		Charleshill	Nojane	Bobonong	Gobojango	Mosu	Morcomasto
1	Provision of animal shade	High	High	High	High	High	High
2	Fodder Production	High	High	High	High	High	High
3	Vaccination and breeding calendar adjustment	High	High	High	High	High	High
4	Correct Stocking rate	High	High	High	High	High	High
5	Feed processing	High	High	High	High	High	High
6	Use of hardy indigenous breeds	High	High	High	High	High	High
7	Harvesting and processing of encroacher plant feed	High	High	High	High	High	High
8	Ethno veterinary practices	High	High	High	High	High	High
9	Water harvesting	High	High	High	High	High	High
10	Pasture re-seeding	High	High	High	High	High	High
11	Manure application	High	High	High	High	High	High
12	Rotational grazing	High	High	High	High	High	High
13	Biogas production	High	High	High	High	High	High
14	Conservation and utilization of indigenous breeds	High	High	High	High	High	High
15	On-farm AI of Cattle	High	High	High	High	High	High
16	Harvesting indigenous plant species for feeds	High	High	High	High	High	High
17	Use of indigenous poultry breeds	High	High	High	High	High	High
18	Dip tanks	High	High	High	High	High	High
19	Mobile laboratory	High	High	High	High	High	High
20	Holistic pasture management	High	High	High	High	High	High
21	Solar energy use	High	High	High	High	High	High
22	Integrated farming	High	High	High	High	High	High
23	Feedlot weaner production	High	High	High	High	High	High
24	Small stock AI	High	High	High	High	High	High
25	Termites chicken feed production	High	High	High	High	High	High
26	Leather processing	High	High	High	High	High	High
27	Kraal rotation	High	High	High	High	High	High
	Key	Rating	not rated	High	Medium	Low	
		Code					

level, through focus group discussions, farmers came up with a list of CSA practices that existed or was perceived to be of importance for their area. The list was presented to extension workers for validation and in many instances, extension workers added more practices to the list. Only two interventions were highly ranked across the three districts, namely, fodder production and vaccination calendar adjustment. The production of fodder is important because without good-quality animal feed, it would be difficult to have adaptation with mitigation co-benefits of reduced greenhouse gases (Herrero et al. 2013). It has been documented that one of the consequences of climate change is increased incidences of disease (Moonga and Chitambo 2010). Adjusting livestock vaccination calendar is therefore relevant and important to control disease and as seasons seem to have shifted, hence the need to vaccinate timeously. Out of the three districts, Gantsi has the most uniform physiography, for example, its soils are predominantly sandy (arenosols). Furthermore, livestock production is very important, with one of the highest livestock populations in Botswana. This scenario can explain the uniform agreement in ranking of the CSA interventions (Table 7).

Due to centuries of drought exposure, smallholder farming systems in the three districts have developed some level of resilience to natural droughts. Nevertheless, the frequent and severe climate change-induced droughts are beyond the coping capacity of these systems, hence the need to climate proof them through appropriate climate-smart agriculture practices. Effective adoption

**Table 7** Implementation plan for fodder production

CSA Technology	Activities	Jan	Feb	Mar	Apr	May	Jun	Jul	Aug	Sep	Oct	Nov	Dec
Fodder production	Land preparation												
	Buying fertilizers												
	Buying seeds												
	Planting												
	Fertilizer application												
	Weeding												
	Harvesting												
	Drying												
	Milling and Packaging												

of climate-smart agriculture requires active participation by farmers not only in identifying constraints to their production but also in developing CSA practices for addressing the identified challenges. This approach requires hybridization of indigenous knowledge with technology. Resilient farming systems lead to sustainable livelihoods, thus, the need for an appreciation of smallholder livelihoods as the anchor on which to build them on. Successful CSA adoption requires co-development of implementation plans by farmers and extension workers.

## References

- Adger WN (2003) Governing natural resources: institutional adaptation and resilience. In: Berkhout F, Leach M, Scoones I (eds) *Negotiating environmental change: new perspectives from social science*. Edward Elgar, Cheltenham, pp 193–208
- Adger WN, Huq S, Brown K, Conway D, Hulme M (2003) Adaptation to climate change in the developing world. *Prog Dev Stud* 3(3):179–195
- AGRA (2017) Africa agriculture status report: the business of smallholder agriculture in. Sub-Saharan Africa (Issue 5)
- Alemaw BR, Chaoka T, Totolo O (2006) Sustainability of rain-fed agriculture in Botswana: a case study in the Pandamatenga plains. *Phys Chem Earth Parts A/B/C* 31(15):960–966. <https://doi.org/10.1016/j.pce.2006.08.009>
- Botswana Government, Botswana Investment and Trade Center, 2019. Annual Report
- Collinson MP (1987) Farming systems research: procedures for technology development. *Exp Agric* 23:365–386
- Cooper et al (2008) Coping better with current climatic variability in the rain-fed farming systems of sub-Saharan Africa: an essential first step in adapting to future climate change? *Agric Ecosyst Environ* 126(1–2):24–35
- Easterling W, Aggarwal P, Batima P, Brander K, Erda L, Howden M, Kirilenko A, Morton J, Soussana J-F, Schmidhuber S, Tubiello F (2007) Food, fibre and forest products. In: Parry ML, Canziani OF, Palutikof JP, van der Linden PJ, Hanson CE (eds) *Climate change 2007: impacts, adaptation and vulnerability*. Contribution of working group II to the fourth assessment report of

- the intergovernmental panel on climate change. Cambridge University Press, Cambridge, pp 273–313
- Elum ZA, Modise DM, Marr A (2017) Farmer's perception of climate change and responsive strategies in three selected provinces of South Africa. *Clim Risk Manag* 16:246–257
- Engelbrecht FA et al (2015) Projections of rapidly rising surface temperatures over Africa under low mitigation. *Environ Res Lett* 10(8):085004. <https://doi.org/10.1088/1748-9326/10/8/085004>
- Eriksen S, O'Brien K, Rosentrater L (2008) Climate change in eastern and southern Africa: impacts, vulnerability and adaptation. *GECHS Rep* 2008(1):27
- FAO (2012) Developing a climate-smart agriculture strategy at the country level: lessons from recent experience. Background paper for the second global conference on agriculture food security and climate change, food and agriculture organization of the United Nations, Rome, Italy
- Herrero M, Havlík P, Valin H, Notenbaert A, Rufino MC, Thornton PK, . . . , Obersteiner M (2013) Biomass use, production, feed efficiencies, and greenhouse gas emissions from global livestock systems. *Proc Natl Acad Sci* 110(52):20888–20893
- Holzkämper A (2017) Adapting agricultural production systems to climate change – what's the use of models? *Agriculture* 7:86. <https://doi.org/10.3390/agriculture7100086>
- Intergovernmental Panel on Climate Change (IPCC) (2007) Climate change, impacts, adaptation, and vulnerability. In: Parry ML, Canziani OF, Palutikof JP, Van der Linden PJ, Hanson CE (eds) Working group II to the fourth assessment report of the intergovernmental panel on climate change. Cambridge University Press, Cambridge
- IPCC (2001) Climate change 2001: impacts, adaptation, and vulnerability. Cambridge University Press, Cambridge, UK
- IPCC (2013) Summary for policymakers. In: Stocker TF, Qin D, Plattner G-K, Tignor M, Allen SK, Boschung J, Nauels A, Xia Y, Bex V, Midgley PM (eds) Climate change 2013: the physical science basis. Contribution of working group I to the fifth assessment report of the Intergovernmental Panel on Climate Change. Cambridge University Press, Cambridge, UK/New York
- Khatri-Chhetria A, Aggarwal PK, Joshi PK, Vyas S (2017) Farmers' prioritization of climate-smart agriculture (CSA) technologies. *Agric Syst* 151:184–191
- Krejcie RV, Morgan DV (1970) Determining sample size for research activities. *Educ Psychol Meas* 30:607–610
- Martin G, Martin-Clouaire R, Duru M (2013) Farming system design to feed the changing world. A review. *Agron Sustain Dev* 33:131–149. <https://doi.org/10.1007/s13593-011-0075-4>
- Maure G et al (2018) The southern African climate under 1.5°C and 2°C of global warming as simulated by CORDEX regional climate models. *Environ Res Lett* 13(6):065002. <https://doi.org/10.1088/1748-9326/aab190>
- Mogomotsi PK, Sekelemani A, Mogomotsi GEJ (2020) Climate change adaptation strategies of small-scale farmers in Ngamiland East, Botswana. *Clim Change* 159:441–460. <https://doi.org/10.1007/s10584-019-02645-w>
- Moonga E, Chitambo H (2010) The role of indigenous knowledge and biodiversity in livestock disease management under climate change. In: 2nd international conference: climate, sustainability and development in semi-arid regions, August, pp 16–20
- Morton JF (2007) The impact of climate change on smallholder and subsistence agriculture. *PNAS* 104(50):19680–19685. <https://doi.org/10.1073/pnas.0701855104>
- Muyambo F, Bahta YT, Jordaan AJ (2017) The role of indigenous knowledge in drought risk reduction: a case of communal farmers in South Africa. *Jamba: J Disaster Risk Stud* 9(1):420. <https://doi.org/10.4102/jamba.v9i1.42>
- Mwongera C et al (2017) Climate smart agriculture rapid appraisal (CSA-RA): a tool for prioritizing context-specific climate smart agriculture technologies. *Agric Syst* 151:192–203
- Nkemelang T, New M, Zaroug M (2018) Temperature and precipitation extremes under current, 1.5 °C and 2.0 °C global warming above pre-industrial levels over Botswana, and implications for climate change vulnerability. *Environ Res Lett* 13(6):1–11
- Obopile M, Karabo O, Tshipinare BP, Losologolo M, Nkosilathi B, Ngwako S, Batlang U, Mashungwa G, Tselaelese N, Pule-Meulenberg F (2018) Increasing yields of cereals: benefits derived from intercropping with legumes and from the associated bacteria. In: Revermann R,

- Krewenka KM, Schmiedel U, Olwoch JM, Helmschrot J, Jurgens N (eds) Climate change and adaptive land management in southern Africa – assessments, changes, challenges and solutions. *Biodiversity & Ecology*, 6. Klaus Hess Publishers, Gottingen/Windhoek, pp 265–271
- Okonya JS, Syndikus K, Kroschel J (2013) Farmers' perception of and coping strategies to climate change: evidence from Six Agro-ecological zones of Uganda. *J Agric Sci* 5(8):252–263
- Pule-Meulenber F, Obopile M, Chimwamurombe P, Bernard N, Losologolo M, Hurek T, Sarkar A, Batlang U, Ngwako S, Schmiedel U, Nanyeni L, Mashungwa G, Tselaesele N, Reinhold-Hurek B (2018) Diversity of wild herbaceous legumes in Southern Africa, their associated root nodule bacteria and insect pests. In: Revermann R, Krewenka KM, Schmiedel U, Olwoch JM, Helmschrot J, Jurgens N (eds) Climate change and adaptive land management in southern Africa – assessments, changes, challenges and solutions. *Biodiversity & ecology*, 6. Klaus Hess Publishers, Gottingen/Windhoek, pp 257–264
- Thomas DS, Twyman C, Osbahr H, Hewitson B (2007) Adaptation to climate change and variability: farmer responses to intra-seasonal precipitation trends in South Africa. *Clim Change* 83(3):301–322
- Thornton P, Dinesh D, Cramer L, Loboguerrero AM, Campbell B (2018) Agriculture in a changing climate: keeping our cool in the face of the hothouse. *Outlook Agric* 47(4):283–290
- Tschakert P (2007) Views from the vulnerable: understanding climatic and other stressors in the Sahel. *Glob Environ Change* 17(3-4):381–396
- Williams PA, Crespo O, Abu M (2019) Adapting to changing climate through improving adaptive capacity at the local level – the case of smallholder horticultural producers in Ghana. *Clim Risk Manag* 23:124–135
- Winsemius HC, Dutra E, Engelbrecht FA, Archer Van Garderen E, Wetterhall F, Pappenberger F, Werner MGF (2014) The potential value of seasonal forecasts in a changing climate in southern Africa. *Hydrol Earth Syst Sci* 18(4):1525–1538
- World Bank (2007) World development report 2008: agriculture For Development. The World Bank, Washington, DC
- World Bank (2010) Africa's infrastructure: a time for transition. The World Bank, Washington, DC

**Open Access** This chapter is licensed under the terms of the Creative Commons Attribution 4.0 International License (<http://creativecommons.org/licenses/by/4.0/>), which permits use, sharing, adaptation, distribution and reproduction in any medium or format, as long as you give appropriate credit to the original author(s) and the source, provide a link to the Creative Commons license and indicate if changes were made.

The images or other third party material in this chapter are included in the chapter's Creative Commons license, unless indicated otherwise in a credit line to the material. If material is not included in the chapter's Creative Commons license and your intended use is not permitted by statutory regulation or exceeds the permitted use, you will need to obtain permission directly from the copyright holder.





# Agroecology and Climate Change Adaptation: Farmers' Experiences in the South African Lowveld

# 20

Cryton Zazu and Anri Manderson

## Contents

Introduction .....	364
Background Information .....	365
The Partnership .....	366
Changes in Climate .....	367
Questions Investigated .....	368
Using the Case Study Evaluation Method .....	369
Evaluation Findings .....	371
Farming Sites .....	371
Demographics .....	372
Reasons for Adopting Agroecological Farming Practices .....	372
The Connection Between Agroecology and Climate Change .....	375
Conclusion .....	376
References .....	377

## Abstract

Motivated by interest to increase the resilience of smallholder farmers to adapt to climate change through uptake of agroecology, two community development organizations commissioned a project evaluation upon which this book chapter is written. The chapter discusses how smallholder farmers were experiencing

---

This chapter was previously published non-open access with exclusive rights reserved by the Publisher. It has been changed retrospectively to open access under a CC BY 4.0 license and the copyright holder is "The Author(s)". For further details, please see the license information at the end of the chapter.

---

C. Zazu (✉)

Environmental Learning Research Centre, Rhodes University, Grahamstown, South Africa

A. Manderson

Hoedspruit Hub, Hoedspruit, South Africa

e-mail: [anri@hoedspruiithub.com](mailto:anri@hoedspruiithub.com)

© The Author(s) 2021

W. Leal Filho et al. (eds.), *African Handbook of Climate Change Adaptation*,  
[https://doi.org/10.1007/978-3-030-45106-6\\_181](https://doi.org/10.1007/978-3-030-45106-6_181)

363

implementing agroecology, trying to understand the reasons for adopting such an approach to farming. The chapter also explores and problematizes the relationship between trends in adoption of agroecology and the smallholder farmers' awareness of climate change and adaptation. The chapter confirms that agronomic and income generation are the key reasons for adoption of agroecology. Most of the farmers reminisced about how their crop yields had declined and soils no longer producing enough to feed the family. Other motivating factors for uptake of agroecology included lack of employment, limited income sources, access to health organic foods, and medicinal value of herbs grown. The chapter further concluded that the correlation between adoption of agroecology and farmers' awareness of it as a climate change adaptation measure is generally weak. Smallholder farmers adopted agroecology more for responding to issues of food security, than any conscious desire to adapt to climate change. Implications of this observation is that practitioners working with smallholder farmers need to rethink their approaches and design of interventions to integrate climate change education and learning, so that strong connections between the agroecological practices promoted and adaptation to climate change are made. Such an approach has potential to improve the sustainability and value of the agroecological practices adopted.

---

**Keywords**

Agroecology · Permaculture · Climate change · Smallholder farmer · Adaptation · Mitigation

---

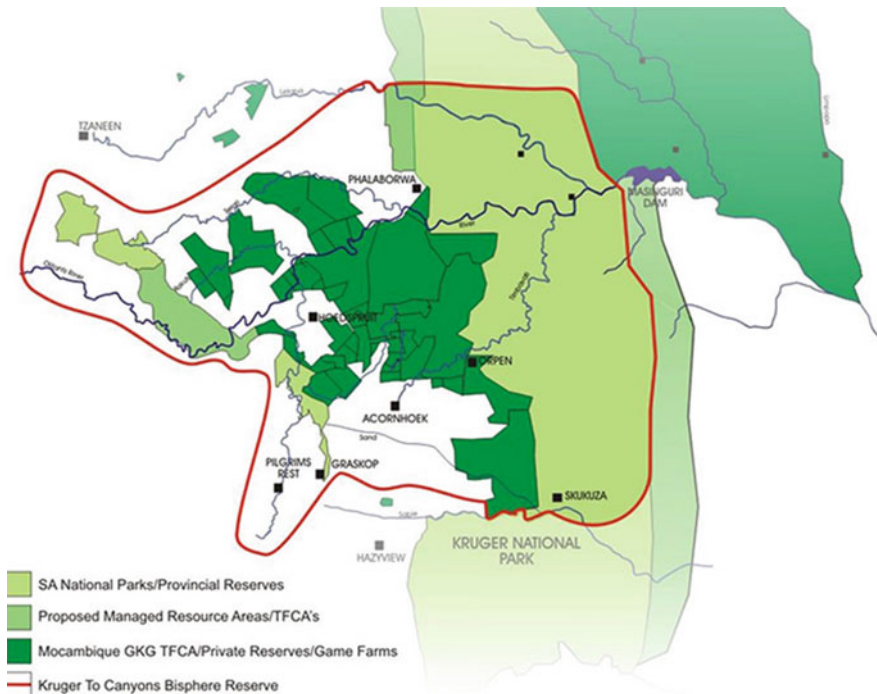
**Introduction**

Social development organizations have noticed an increase in agroecological activity among smallholder farmers in the South African lowveld in the last 2 years, including in the districts of the Kruger to Canyons Biosphere Region. Agroecology has also become the point of convergence for a network of institutions based in the biosphere and focusing on a range of environmental, climate change, and social concerns. These institutions included the Hoedspruit Hub, Association for Water and Rural Development (AWARD) Mahlatini, Ukuvuna, Kruger to Canyons Biosphere, CHoiCE Trust, Hlokomela, SANParks, and others, who have mandates ranging from agricultural training, poverty alleviation, biodiversity, and water conservation through to health, yet for different reasons have all found agroecology a critical component to realizing these mandates and notably building farmers resilience to adapt to climate change. It is against this context that two of these organizations working in partnership to promote agroecology among smallholder farmers in this area, collaborated to develop this chapter with the aim of sharing the findings of an evaluation conducted to understand the participating smallholder farmers' experiences of agroecology as both a livelihood option and a strategy for climate change adaptation.

## Background Information

Kruger to Canyons Biosphere Region encompasses parts of the Limpopo and Mpumalanga provinces, as well as three southern African biomes: grasslands, Afro-montane forests, and the savannah of the lowveld. And as shown in Fig. 1 below, the region borders with the vast Greater Kruger National Park, which is home to a diversity of flora and fauna. The Kruger to Canyons region also include much of both the upper and lower sub-catchment areas of the Olifants river. Major land-use practices in this region include conservation nature reserves areas, mining (gold, phosphate, copper), exotic plantations, and the extensive nonorganic cultivation of subtropical fruits and vegetables (mainly for export) and to a lesser extent peasant farming.

Perhaps the most important contextual history of this area, when considering the development of smallholder agriculture in post-apartheid South Africa, is the remnants of the former apartheid homelands or bantustans. These were areas the apartheid government set aside for African indigenous people to live after they were forcibly removed from urban areas. It was thus the mechanism with which the government realized segregation, but with which they also successfully created labor reservoirs for the mines and other South Africa industries active at the time. It is essential to take into consideration that although the apartheid government



**Fig. 1** Map of Kruger to Canyon landscape (AWARD 2016)



intended for these areas to eventually become independent, they were not developed and relied entirely on the larger South African economy.

Vibert (2018) wrote a poignant piece about the effects of forceful removals during apartheid, which displaced people and gathered them in the former homelands. She writes specifically about one homeland that was partly located within the current biosphere, named Gazankulu. It “was envisioned as a rural enclave for women, children, and elderly people of Tsonga ethnicity – their men were the labour force in the mines and cities. This rural-urban binary is misleading: people and resources circulated among these spaces, within and in infraction of the strict spatial regulations of apartheid. Yet rural space was, under apartheid, a space apart” (Vibert 2018). Vibert writes how women recall arriving in this new space where very little preparations had been made for their arrival, finding it inhospitable. They built houses during the day and cooked at night to start a new life. They did not have enough allocated space to grow crops such as sorghum, which they had grown before.

...We can't forget sorghum,' the indigenous grain they no longer have space or labour to grow. Mamayila says it's 'very painful [va va ngopfu] to remember the way we were situated. It was so nice. You had enough land to have your garden, donkeys, cattle kraal, one side for goats, one side for pigs.' Today we have 'maybe a cattle-kraal size' says Sara. (Vibert 2018)

Since the end of apartheid, not enough has been done to address the social complexities and trauma of the forceful removals or the underdevelopment of these former homelands, resulting among other social challenges, in millions of unemployed people. Given the legacy of Apartheid's forced removals, villages in Gazankulu are densely populated (Wright et al. 2013). And overutilization of natural resources combined with a lack of proper management of these resources has led to soil erosion and a loss of soil moisture and soil nutrients. These factors, together with low rainfall and poor soils in some areas, have affected smallholder farmer's capacity to produce enough food (AWARD 2016) and with climate change, their vulnerabilities are likely to increase.

Therefore, the work being done by the two development organizations is implemented within this context where historical segregation and limited formal development have left millions of people heavily dependent of agriculture and social grants as livelihoods options.

---

## The Partnership

One of the two development organization is registered as a private company but operates as a social enterprise and training center in the Hoedspruit region. Its social development activities include a high school bursary program, and the training on agroecology, which is of interest to this chapter. The course is meant to equip smallholder farmers with skills and knowledge needed to practice agroecology as a form entrepreneurship along the organic food value chain.



**Fig. 2** Map of the Olifants river sub-catchment in which agroecology projects are being implemented (AWARD 2016)

The other organization is a nonprofit organization specializing in multi-disciplinary, participatory, research-based project implementation aimed at addressing issues of environmental sustainability, inequity, and poverty, in particular relating to water conservation and management in the face of climate change. This organization's main geographical area of focus, although not exclusively limited to, is in the areas lying within the lower and upper catchment of the Olifants river – a major tributary of the Limpopo river, which is an international watercourse shared between South Africa and Mozambique. Figure 2 below is a map showing the entire Olifants river catchment.

## Changes in Climate

Also, of interest in this chapter is how climate change is being experienced in southern Africa and how this will impact on agriculture. A recent piece in the Farmer's Weekly by Lindie Botha, drawing on the opinion of Prof. Francois Engelbrecht, chief researcher for climate studies, modelling, and environmental health at the Council for Scientific and Industrial Research (CSIR), states that “the average temperature increase in southern Africa due to climate change, is taking place at twice the global rate. The resulting lower rainfall figures and increase in the number of heatwaves will see agricultural landscapes shifting and veld fires growing in frequency. All of this will demand careful planning” and a type of agriculture that is climate smart (Botha 2019). She writes that the Department of Science and

Technology launched the South African Risk and Vulnerability Atlas (SARVA) in response to the changing climates observed in the last few decades. SARVA published in 2018 that rural areas in South Africa are particularly vulnerable to climate change due to its dependence on water and agriculture.

It is against this background that the two partner organizations have, over the course of the partnership, trained and supported a total of 300 smallholder farmers to implement agroecology. And the need to learn more about how the target smallholder farmers are experiencing their implementation of agroecology is what motivate the evaluation, whose findings are discussed in this chapter

---

## Questions Investigated

In order to gain an in-depth understanding of the farmers' experiences of adopting and implementing agroecology, the project evaluation against which this chapter is developed explored the following questions:

1. Why do smallholder farmers adopt an agroecological approach to farming?
2. Is adoption of agroecology as strategy for adaptation linked to farmers' awareness of climate change itself?

Exploring these evaluative questions was done in order to confirm if the agroecological approach is indeed the most effective way to not only meet organizational goals but to enhance the building of smallholder farmers' resilience to adapt to climate change. The answers to the questions of this evaluation are thus the basis for discussions presented in this chapter, the ultimate aim being to improve the way community development organizations work with and support smallholder farmers in South Africa and beyond.

The evaluation was conducted using a qualitative interpretive research approach. The decision to use a qualitative methodology was in sync with the nature of the evaluative questions that the two organizations sought to answer and also the ontological world views of what constitute reality held by the researchers (Creswell 2009; Niewenhuis 2007). Ontology, as defined by Niewenhuis (2007), refers to how one perceives reality or think of that which can be known. Similarly, Patton (2002, 2014) argued that ontology is concerned about the constitution of reality, in the case of this study, "farmers views and experiences of agroecology," and what we are able to know about it. Creswell (2009) also pointed out that ontological world views often shape the orientation and design of the evaluation methodology preferred. Hence the qualitative interpretive paradigm within which this evaluation was conducted, and the case study method used together with the data collection and analysis techniques all reflects the ontological viewpoint of knowledge as socially constructed (Denzin and Lincoln 2011; Maxwell 2010; Yin 2013). An evaluation methodology that does not only focus on the numbers of farmers trained and now then practicing agroecology was needed. Therefore, knowledge interest that required much more than just statistics for donor reporting determined the use of qualitative methodologies. And a

qualitative approach allowed the evaluators to generate more insights into farmers experiences illuminating light on some of the grey areas where future programming needed to resolve in order to achieve not only more but sustainable impact, working with smallholder farmers in Limpopo to adapt to climate change.

---

## Using the Case Study Evaluation Method

According to Harrison et al. (2017), case study research has grown in reputation as an effective means to explore and understand complex issues in real-world settings. It has been widely used across several disciplines, particularly the social sciences, education, business, law, and health, to address a wide range of research questions.

The case study method used in this evaluation allowed for a closer examination and analysis of each participating smallholder agroecology farmer in real-life contexts (Harrison et al. 2017). It also allowed the evaluators an opportunity to select information rich participants or cases (Flyvbjerg 2006, 2011) making it possible to generate enough data and in-depth insights into how agroecology is being experienced by and changing the lives of smallholder farmers. It also allowed them to probe in detail the extent to which farmers understand the connection between adopting agroecology and building their resilience to climate change.

Fifteen carefully selected cases of smallholder farmer households drawn from 300 farmers trained and being supported to implement agroecology. These households were purposively selected on the basis of having received training and actively implementing agroecological practices. Purposive sampling meant that the researchers had to pick on the most productive sample (smallholder farmers) that could provide adequate data to answer the research questions (Marshall 1996; Flyvbjerg 2006, 2011). It also allowed for the selection of what Yin (2014) referred to as *data rich* participants. And because this was not a comparative analytical evaluation, selecting those data-rich cases made much epistemological sense.

As represented in Table 1, the farmers involved in the evaluation included those that had been trained through 17 Shaft Training in 2015 and 2016 and those trained by Hoedspruit Hub in 2016 and 2017.

Evaluation information was collected using semi-structured interviews integrated with narrative enquiry and field observation. Yin (2014) argued that semi-structured interviews allow a researcher greater freedom to pursue unexpected, but interesting and relevant comments to a greater depth. Instead of a scripted list of questions, the researcher has a good idea of the questions she would like to ask, and perhaps even an interview guide, but may ask the questions in a way that fit the context of the emerging conversation between researcher and participant smallholder farmer (Yin 2014; Creswell 2009). Also important for a qualitative evaluation such as this one the use of semi-structured interviews allowed the farmers to answer questions in their own words, potentially adding details to the data that might have been missed otherwise (Yin 2011). The interview guide used to collect demographic information relating on participants profiles also provided a way of generating quantitative data

**Table 1** The smallholder farmers participating in the evaluation and their training

Code name	Training received
1	Leadership in Agroecology
2	17 Shaft Training (2016)
3	Organic Mango Production
4	17 Shaft Training (2015)
5	Organic Mango Production
6	Herb Gardening
7	Leadership in Agroecology
8	Herb Gardening
9	17 Shaft Training (2016)
10	17 Shaft Training (2015)
11	Entrepreneurship in Agroecology (2016)
12	17 Shaft Training (2016)
13	Entrepreneurship in Agroecology (2016) (not interviewed yet)
14	Leadership in Agroecology
15	Agroecology for the Youth

on harvest and income trends being experienced by smallholder farmers implementing agroecology.

Information collection also entailed use of narrative enquiry where farmers were asked to tell their stories of change. Dyson and Genishi (1994) asserts that storytelling provides a useful theoretical lens through which to examine the ways in which individuals experience the world as illustrated through their own personal stories. Narrative inquiry helped the evaluators to capture the farmers' full experiences of their adoption and implementation of agroecological farming practices. Davis (2007) also argued that storytelling is a very useful way of collecting data especially from informants with low literacy levels such as the case with most of the farmers involved in this project evaluation. As such storytelling helped to make this project evaluation socially inclusive in orientation.

With the consent of participants, their stories and responses to interviews were audio recorded for data transcription and analysis. Some of the interviews were video recorded and footage stored for the future development of a short video film to support the sharing of the emerging findings of the project evaluation.

In order to deepen insights and triangulate information collected through the interviews (Shenton 2004), field observations were conducted and entailed visiting homesteads of all the 15 farmers to learn more about their agroecological practices and ascertain harvests being experienced. Photography was used to capture observations made during the field trips.

In total, 15 interviews were done, and visits to all the 15 farmers undertaken. The data generated was processed through transcribing, translation into English, making it ready for analysis

Information collected was subjected to initial analysis using Atlas Ti 7 to both locate and code the data (Friese 2014). Dohan and Sanchez-Jankowski (1998)

argued that coding data with a well-designed computer program like Atlas Ti 7 can be very useful but not an end in itself. Analysis of data was thus continued using thematic data analysis where emerging themes relating to questions being pursued in the evaluation and discussed in this handbook chapter were identified and analyzed.

## Evaluation Findings

### Farming Sites

The 15 smallholder farmers who participated in this project evaluation were drawn from the villages as shown in the map below. All these villages are adjacent to the Kruger to Canyons Biosphere area and falls within Maruleng, Lepele Nkhumpi, and Elias Motshoaledi municipalities of Limpopo province. In terms of climate, these areas are generally quite dry with an annual rainfall of around 500 mm/year concentrated in 4 months during the summer (AWARD 2016).

Farmers were selected from villages such as Sidawa, Zebedela, Turkey, and Mametja of Maruleng, and Motetema, Tarfelskop, Makweng, Dithabaneng, Makushoaneng, and Monsterlus of Capricorn and Elias Motshoaledi (Fig. 3).



Fig. 3 Villages implementing agroecology (AWARD 2016)

**Table 2** Smallholder farmer demographics

Code	Age	Gender	Size of family	Years farming	Production area (ha)
1	48	Female	3	6	0,540
2	41	Female	6	2	0,035
3	53	Female	4	1	0,534
4	44	Female	5	26	0,500
5	56	Male	4	1	0,003
6	40	Male	5	10	0,500
7	52	Female	5	2	0,002
8	58	Female	3	2	0,250
9	20	Female	5	0.2	N.A.
10	59	Female	3	10	N.A.
11	28	Female	2	2	0,200
12	30	Male	5	3	0,420
13	39	Female	3	7	0,200
14	44	Female	6	3	0,500
15	48	Male	2	4	0,032
<b>Averages</b>	45,3		4	5,6	0,28

## Demographics

Of the 15 farmers interviewed, 11 were female and 4 were male. Average age of the smallholder farmers interviewed was 45.3, with the youngest being 20 years old. On average, each household size was reported as made up six family members.

The plot sizes for most farmers ranged from 0,002 ha (an area of 4 m × 5 m) being the smallest to the largest of 0,54 ha. Each farmer was producing a good mix of vegetables with limited fruit and herbs. Those farming herbs were benefiting from the market linkage support that Hoedspruit Hub was providing. Table 2 illustrates the above demographics of the farmers.

## Reasons for Adopting Agroecological Farming Practices

The chapter confirms that most of the farmers interviewed has various reasons for practicing agroecology. These reasons ranged from the need to produce more food for household consumption, desire to generate income, and influence from neighbors to the farmers' realization of declining yields.

Asked to share his motivation for taking up and practicing agroecology one of the farmers was quoted saying:

Remember the first thing which is needed by the family before they do any job is food. So for me, I work for food first and then seek money elsewhere. (F2)

Similarly, the other farmer interviewed weighted in by pointing out that:

When I started implementing the permaculture (agroecology) ideas, I noticed that my vegetable production doubled, compared to the first yield where I had little knowledge. This method is cheap and sustainable long term. (F4)

Asked to explain why adopting agroecology and converting from the usual conventional farming, another farmer confidently said that:

I have a diversity of activities in order to produce a wide variety of results such as generating income, providing my family with meat and vegetables. (F7)

Two of the interviewed farmers were despite trained, however, not yet practicing agroecology. The two perceived agroecology as for mainly very small farmers, thus not very suitable for their scale of farming.

It became quite clear that the smallholder farmers interviewed were practicing agroecology because of different reasons. These as reflected above included the both the need to feed their families and earn income from selling the surplus backyard gardening produce. Producing more food to feed the family and income generation as, confirmed by responses from 66% ( $n = 10$ ) of farmers interviewed, emerged the top two reasons influencing adoption and practicing of agroecology. The desire to improve household income as a reason for practicing agroecology was made much more explicit by a farmer who shared her story as quoted below.

Life with my children and no support from their father was not a good life for me at all. I tried many things to improve the living conditions of my children. I received government benefit but it was not enough to send them to school, provide medical support and to buy the right food. One of the areas I got passionate about was farming, but I had no skills. But then I got training in agroecology and started from a small base growing a few vegetables and crops. . . . and now I earn more money and I am happy. . . . (F10)

The desire to produce food for the family, to share with neighbors, and sell the surplus to generate income is illustrated in Table 3.

Other influencing factors included realization that their soils are no longer producing as much as they used to, keeping up with the jones (learning from neighbors) and as well lack of employment opportunities especially among the youth in the lowveld. About 33% ( $n = 5$ ) of active agroecological farmers were unemployed and many cited this as the original reason for starting their agroecological production units. For many farmers, continued unemployment meant no other option than to continue farming agroecologically. One farmer alluded to the medicinal value of herbs as the reasons for his interest in doing agroecology. Access to market and increasing demand for organic vegetables by local lodges were also mentioned as factors shaping the way agroecology was being adopted and implemented. Also, very interesting is that a few farmers thought that agroecology is easier and cheaper to do as it does not require heavy use of chemicals and fertilizers. Ecological reasons for implementing agroecological farming practices



**Table 3** Household consumption, sharing, and selling of agro-produce

Code	Household use (%)	Sharing (%)	Selling (%)	Income p.m. (rands)
F1	54	22	24	900
F2	20	80	0	0
F3	20	0	80	600
F4	50	0	50	5000
F5	10	10	80	1200
F6	20	0	80	800
F7	20	40	40	200
F8	10	0	90	300
F9	N.A.	N.A.	N.A.	0
F10	N.A.	N.A.	N.A.	0
F11	100	0	0	0
F12	60	0	40	420
F13	40	5	55	5100
F14	90	5	5	120
F15	20	10	70	600
Avg	33,77	16,88	49,33	1016,00

were also observed and some of the farmers talked of the need to improve soil health and save water. Asked to explain why she adopted agroecology, one farmer felt agroecology enabled communities to live in harmony with nature, and she said that,

To me it would be beneficial if more people can farm agroecologically and if they can impart it to their children. People say they are going to pray for rain. We are not living harmoniously with nature, and not sending rain is nature's response. It's how nature talks

The desire to save water which was also linked to ecological reasons for taking up agroecology could be easily understood from the fact that most of the farmers in the area covered by this evaluation (lowveld of Limpopo) did not have reliable water supply and were actually buying water (Award 2016) to sustain their gardens. Water was therefore even without or before onset of climate change a scarce resource. Others talked of social motivations including that gardening kept them physically active and healthy, reducing stress, and keeping them out of poverty and criminal activities.

The observations made above were also reported by similar research studies. Studies done by Nilesa and Mueller (2016) revealed that farmers change their agricultural behaviors not only because of the changes in climatic conditions. The evaluation findings revealed that factors such as the inherent desire to sustain food security and the changes in the wider environment, e.g., changes in soil fertility and productivity levels, contributed to the changes in agricultural practices adopted by farmers. Scholars such as Toffolini et al. (2018) also revealed that the evolution of farmers' practices towards agroecology is mainly influenced by agronomist factors to increase food production. In a similar sense, Hubert (2012) also observed that

agroecology has, in various countries, been considered a viable option for achieving sustainable food production systems. Accordingly, Altieri (1999) claimed that the agroecological approach provides an alternate path to increasing crop production because of its reliance on local farming knowledge and technologies suited to different and marginal climatic conditions such as those of Limpopo.

---

## The Connection Between Agroecology and Climate Change

Out of the 15 farmers interviewed in this project review, only one ( $n = 1$ ) of them made an explicit reference to climate change. This is a very interesting observation but one that is unusual. Such an observation can be understood from what other studies has revealed. Nilesa and Mueller (2016) pointed out that they are unaware of any studies that have examined the extent to which farmers' perception of climate change directly explains their changes in farming practices. Whyte (2014) also observed that even though the broad issue of adaptation to environmental change is not new for many indigenous peoples, it is something done out of survival instincts rather than any significant levels of climate change awareness. Closely related, Mugambiwa (2018) concluded that subsistence farmers have always adopted adaptive strategies to changes such declining crop yields. In his study, he concluded that changes in farming practices such as a shift from maize to traditional millet and sorghum that farmers in Mutoko, a district in Zimbabwe, adopted were triggered by the desire to preserve local indigenous knowledges and cultures rather than the changing climatic conditions. However, it can be argued that this change and adoption of indigenous knowledge practices as acknowledged by Waha et al. (2013) to respond to frequent droughts, scarcity of rain, and decreased crop yields is by default a strategy for adapting to climate change.

Other studies done by Arbuckle et al. (2013) and Niles et al. (2015) to investigate farmers' perceptions of climate change, its risks, and potential to influence adoption of adaptation and mitigation behaviors also confirmed that farmers relate more to weather than climate change. This observation is also reflected in what one farmer who made reference to climate change was quoted saying,

Then I ask myself, isn't it important to know, what is hindering rain from coming? So, all these practices we are doing, it's hindering rain from coming, by contributing to climate change. We can pray and pray and pray, but if we don't change our thinking, decolonise our minds, rain will not come. We can expect drought

Farmers are therefore arguably more affected by weather-related losses than climate change per se. Thangata et al. (2002) argued that the decisions made by smallholder farmers to adopt agroecological practices, e.g., agroforestry, in the context of Zambia reflected the farmers' perceptions of worst-case weather changes such as delayed rainfall or droughts. And thus, if they were asked about how weather determines their farming practices, a good number of the farmers involved in this

evaluation could have provided more explicit answers. This finding denotes the need to appreciate that for most farmers the adoption of agroecology is, at experience level, motivated more by other factors than solely climate change (Palm et al. 2010; Beddington et al. 2011; Nyanga et al. 2011).

While agroecology has been widely associated with strengthening the resilience of farmers and rural communities (Niles et al. 2015), evidence to support that adoption of agroecological practices is a direct result of the farmer's awareness of climate change remains anecdotal. Nyanga et al. (2011), in a study done in Zambia, also reported of a positive correlation between perception of increased droughts and adoption of conservation agricultural practices such as agroecology but no correlation between farmer's attitudes towards climate change itself. The increased interest in agroecology has also been not only linked to climate change but other narratives such as the green revolution. Hence the tendency to give function to agroecology and all its associated soil, water, and biodiversity conservation technologies, as a strategy for climate change adaptation, can only be referred to as of zero interest from the perspective of farmers. Other scholars have further critiqued the way agroecology has now been hijacked by the politics of the day and repackaged as climate smart agriculture. The implication of the observation made here is that it is just as important to know the priorities of the farmer implementing agroecology practice than to present it as solely a climate change adaptation measure.

---

## Conclusion

While the work done by the two development organizations who commissioned the writing of this chapter is aimed at building resilience for climate change adaptation, it is important to note that farmers' decisions to adopt agroecology is influenced by many other factors. This observation gives added value to the need for additional interventions such as the dialogues for climate change literacy and adaptation (DICLAD) which can improve farmers' levels of knowledge and awareness of climate change, and how this relates to adopted agroecological practices being implemented.

In general, the findings discussed in this chapter also calls for a redesign of contemporary farmer extension support services. There is need to adopt approaches that not only empowers farmers with basic knowledge of climate change science but also recognize that agroecological practices and technologies have a history that is tied to a range of evolving farmer's priorities. Working with farmers and getting them to a level of consciousness that recognizes the value of their indigenous agroecological knowledges and systems for more than just climate change adaptation is what must be pursued. Therefore, advancing the climate change adaptation dimension of agroecology at the expense of the other equally important roles and values is not only reductionist but problematic.

## References

- Altieri MA (1995) *Agroecology: the science of sustainable agriculture*. Westview Press, Boulder
- Altieri MA (1999) Applying agroecology to enhance the productivity of peasant farming systems in Latin America. *Environ Dev Sustain* 1:197–217
- Arbuckle et al (2013) Climate change beliefs, concerns, and attitudes toward adaptation and mitigation among farmers in the Midwestern United States. *Clim Change* 117:943–950
- AWARD (2016) Grain-SA smallholder farmer innovation Programme, annual report (2015–2016). Limpopo, South Africa
- Beddington et al (2011) Achieving food security in the face of climate change: summary for policy makers from the commission on sustainable agriculture and climate change. In CGIAR Research Program on Climate Change, Agriculture and Food Security (CCAFS), Copenhagen. Available on <http://www.ccafs.cgiar.org/commission>. Accessed 10 June 2020
- Botha L (2019) Climate change: it's happening faster than you think. *Farmers Weekly*, 7 January. Available: <https://www.farmersweekly.co.za/agri-technology/farming-for-tomorrow/climate-change-happening-faster-think/>. Accessed 4 Jan 2020
- Creswell JW (2009) *Research design. Qualitative, quantitative and mixed methods approaches*, 3rd edn. SAGE, London
- Creswell JW (2013) *Qualitative inquiry and research design: choosing among five approaches*. SAGE, Thousand Oaks
- Creswell JW, Plano CV (2007) *Designing and conducting mixed methods research*. SAGE, Thousand Oaks
- Davies MB (2007) *Doing a successful research project, using qualitative or quantitative methods*. Palgrave Macmillan, New York
- Davis P (2007) Storytelling as a democratic approach to data collection: interviewing children about reading. *Educ Res* 49(2):169–184
- Denzin NK, Lincoln YS (2011) Introduction: the discipline and practice of qualitative research. In: Denzin NK, Lincoln YS (eds) *The Sage handbook of qualitative research*, 4th edn. SAGE, Thousand Oaks, pp 1–20
- Dohan M, Sanchez-J M (1998) Using computers to analyse ethnographic field data: theory and practical considerations. *Annu Rev Sociol* 24:477–498
- Dyson AH, Genishi C (1994) *The Need for Story: Cultural Diversity in Classroom and Community*. National Council of Teachers of English, 1111 W. Kenyon Rd., Urbana, IL 61801-1096
- Flyvbjerg B (2006) *Qualitative inquiry: five misunderstandings about case-study research*. SAGE, London
- Flyvbjerg B (2011) Case study. In: Denzin NK, Lincoln YS (eds) *The Sage handbook of qualitative research*, 4th edn. SAGE, Thousand Oaks, pp 301–316
- Friese S (2014) *Qualitative data analysis with ATLAS.ti*, 2nd edn. SAGE, London
- Gillham B (2005) *Cases study research method*. Continuum, New York
- Harrison H, Birks M, Franklin R, Mills J (2017) Case study research: foundations and methodological orientations. *Forum Qual Soc Res* 18(1):Art 19. <http://nbn-resolving.de/urn:nbn:de:0114-fqs1701195>. Accessed 19 May 2020
- Hubert C (2012) Agrarian dynamics and population growth in Burundi: Agroecology before its time. [core.ac.uk/display/87834265](http://core.ac.uk/display/87834265). Accessed 10 June 2019
- Marshall MN (1996) Sampling for Qualitative Research. *Family Practice* 13:522–525. <https://doi.org/10.1093/fampra/13.6.522>. Accessed 14 Aug 2019
- Maxwell JA (2010) *Qualitative Research Design: An Interactive Approach (Applied Social Research Methods)* 3rd Edition. Sage
- Mugambiwa SS (2018) *Adaptation measures to sustain indigenous practices and the use of indigenous knowledge systems to adapt to climate change in Mutoko rural district of Zimbabwe*. Unpublished PhD study
- Muhammad A, Janpeter S, Jürgen S, Farhad Z (2016) Climate change vulnerability, adaptation and risk perceptions at farm level in Punjab, Pakistan. *Sci Total Environ* 547:447–460

- Niewenhuis J (2007) Qualitative research design and data gathering techniques. In: Maree K (ed) *First steps in research*. Van Schaik Publishers, Pretoria
- Niles MT, Lubell M, Brown M (2015) How limiting factors drive agricultural adaptation to climate change agriculture. *Ecosystem Environ* 200:178–185
- Nilesa MT, Mueller ND (2016) Farmer perceptions of climate change: associations with observed temperature and precipitation trends, irrigation, and climate beliefs. *Glob Environ Chang* 39:133–142
- Nyanga P, Johnsen F, Kalinda T (2011) Smallholder ‘farmers’ perceptions of climate change and conservation agriculture: evidence from Zambia. *J Sustain Dev* 4(4):73–85
- Palm C et al (2010) Identifying potential synergies and trade-offs for meeting food security and climate change objectives in sub-Saharan Africa. *Proc Natl Acad Sci* 107(46):19661–19666
- Patton MQ (2002) *Qualitative research and evaluation methods*, 3rd edn. SAGE, London
- Patton MQ (2014) *Qualitative research and evaluation methods. Integrating theory and practice*. SAGE, London
- Patton MQ (2017) *Facilitating evaluation. Principles in practice*. SAGE, London
- Prokopy et al (2015) Farmers and climate change: a cross-national comparison of beliefs and risk perceptions in high-income countries. *Environ Manag* 56:492–504
- Shenton AK (2004) Strategies for ensuring trustworthiness in qualitative research projects. In *Education for Information*. London: IOS Press
- Terre Blanche M, Kelly K (1999) Interpretive methods. In: Terre Blanche M, Durrheim K (eds) *Research in practice. Applied methods for the social sciences*. UCT, Cape Town
- Thangata P, Hildebrand P, Gladwin C (2002) Modelling agroforestry adoption and household decision making in Malawi. *Afr Stud Q* 6(1–2):249–268
- Thomas DR (2006) A general inductive approach for analyzing qualitative evaluation data. *Am J Eval* 27(2):237–246. <https://doi.org/10.1177/1098214005283748>. Accessed 12 May 2020
- Toffolini Q et al (2018) Agroecology as farmers’ situated ways of acting: a conceptual framework. *Agroecol Sustain Food Syst*
- Vibert E (2018) Healing in the soil. *Womensfarm.org*. <https://www.womensfarm.org/hleketani-garden/healing-in-the-soil/>. Accessed 14 Jan 2019
- Waha K, Bondeau A, Müller C (2013) Adaptation to climate change through the choice of cropping system and sowing date in sub-Saharan Africa. *Glob Environ Chang* 23(1):130–143
- Whyte KP (2014) A concern about shifting interactions between indigenous and nonindigenous parties in U.S. climate adaptation contexts. *Interdiscip Environ Rev*, Vol. X, No. Y, XXX
- Wright et al (2013) Lower Olifants community health: risks and opportunities. Project report
- Yin R (2013) *Case Study Research: Design and Methods*. SAGE Publications
- Yin RK (2009) *Case study research: design and methods*. SAGE, Thousand Oaks
- Yin RK (2011) *Qualitative research from start to finish*. Guilford Press, New York
- Yin RK (2014) *Case study research: design and methods*. SAGE, Los Angeles

**Open Access** This chapter is licensed under the terms of the Creative Commons Attribution 4.0 International License (<http://creativecommons.org/licenses/by/4.0/>), which permits use, sharing, adaptation, distribution and reproduction in any medium or format, as long as you give appropriate credit to the original author(s) and the source, provide a link to the Creative Commons license and indicate if changes were made.

The images or other third party material in this chapter are included in the chapter’s Creative Commons license, unless indicated otherwise in a credit line to the material. If material is not included in the chapter’s Creative Commons license and your intended use is not permitted by statutory regulation or exceeds the permitted use, you will need to obtain permission directly from the copyright holder.





# Climate Change and Variability on Food Security of Rural Household: Central Highlands, Ethiopia

# 21

Argaw Tesfaye and Arragaw Alemayehu

## Contents

Introduction .....	380
Impact of Climate Change and Variability on Food Security of Rural Household .....	384
Variability and Trends in Rainfall and Temperature .....	384
Rural Household Perceptions of Climate Change and Variability and Their Impacts .....	389
Impacts of Climate Change and Variability on Food Security of Rural Households .....	390
Household Food Security Status .....	391
References .....	393

## Abstract

This chapter analyzes the impact of climate change and variability on food security of rural households in the central highlands of Ethiopia taking Basona Werana district as a case study site. Data were obtained from 123 households selected using simple random sampling from three agro ecological zones. Key informant interviews and focus group discussion (FDG) were used to supplement the data obtained from household survey. The monthly rainfall and temperature data are for 56 points of 10 × 10 km grids reconstructed from weather stations

This chapter was previously published non-open access with exclusive rights reserved by the Publisher. It has been changed retrospectively to open access under a CC BY 4.0 license and the copyright holder is “The Author(s)”. For further details, please see the license information at the end of the chapter.

A. Tesfaye (✉)

Department of Geography and Environmental Studies, Mekdela Amba University, Mekane Selam, Ethiopia

A. Alemayehu

Department of Geography and Environmental Studies, Debre Berhan University, Debre Berhan, Ethiopia

© The Author(s) 2021

W. Leal Filho et al. (eds.), *African Handbook of Climate Change Adaptation*,  
[https://doi.org/10.1007/978-3-030-45106-6\\_188](https://doi.org/10.1007/978-3-030-45106-6_188)

379

and meteorological satellite observations, which cover the period between 1983 and 2016. Standardized rainfall anomaly (SRA), linear regression (LR), and coefficient of variation (CV) are used to examine inter-annual and intra-annual variability of rainfall. Annual and seasonal rainfalls show decreasing trends over the period of observation. The decreasing trends in annual and March–May (Belg) rainfall totals exhibit statically significant decreasing trends at  $p = 0.05$  level. Kiremt (June–September) shows statically significant decreasing trends at  $p = 0.1$  level. Mean annual maximum and minimum temperatures show statically significant increasing trends at  $p = 0.05$  level. More than 80% of households perceived that the climate is changing and their livelihoods (crop and livestock production) are impacted. The district belongs to one of the most vulnerable areas to climate change and variability in the country where large proportions of households (62%) are under different food insecurity classes. Results suggest that local level investigations are useful in developing context-specific climate change adaptation.

---

**Keywords**

Climate variability · Rainfall and temperature trends · Food security · Ethiopia

---

## Introduction

Africa is already affected by climatic extremes such as floods, droughts, and windstorms, which are aggravated by climate change and variability. Ethiopia is one of the African countries which is most vulnerable to drought and floods (Belay et al. 2017). Climate change in the form of rising temperature, variable rainfall, droughts, and flooding affects agricultural production and threatens food security in low-income and agriculture-based economies (Mongi et al. 2010; Mesike and Esekhad 2014). Agriculture in Ethiopia is a major source of food and contributing sector to food security. It plays a key role in generating surplus capital to speed up the socioeconomic development of the country (Adem et al. 2018; Hagos et al. 2019).

Achieving food security and end hunger in the face of the ongoing impacts of climate change and variability is at the heart of the sustainable development goals. Climate change and variability are currently the biggest challenge affecting countries where rainfed agriculture is a means of livelihood (Asfaw et al. 2017).

The impact of climate change and variability on agricultural production increases economic and social challenges. Climate change affects agriculture in a different way. Climate extremes and changes in rainfall pattern are already influencing agricultural productivity. Increased tension in households, increased lethargy, poor school performance, and a range of other social ills are the major social impacts mostly reported (Akinseye et al. 2013).

Climate change and variability affect four dimensions of food security, namely, food availability, food accessibility, food utilization, and food system stability. The

most direct impact on food security is through changes in food production. Short-term variations are likely to be influenced by extreme weather events that disrupt production cycles (Alemu and Mengistu 2019). Climate change and variability affect food availability through its impacts on economic growth, income distribution, and agricultural demand markets, food prices, and supply chain (Schmidhuber and Tubiello 2007).

Historically, Ethiopia is well known for being prone to extreme events. The rainfall over Ethiopia exhibited high variability (Suryabhadgavan 2017), and the country's economy has been affected by long-term changes in both rainfall amount and distribution where the country has witnessed frequent incidents of both excessive and deficient rainfalls (Zelege et al. 2017). The most common drought periods known are 1957–1958, 1972–1974, 1984–1985, 2002–2003, and 2015–2016 (Markos 1997; Suryabhadgavan 2017).

The central highland of Ethiopia, where the study area is located, is a drought- and famine-prone area. The people mainly derive their livelihood from subsistence agriculture, which is characterized by mixed farming system on fragmented land, over utilized land, and affected by erratic rainfall (Alemayehu and Bewket 2016a). Minor droughts are common every year due to climate variability. This brought an impact on the poor performance of the agricultural sector which affects rural livelihoods and food security (Asfaw et al. 2017). The central highland of Ethiopia is already food insecure, and large parts of the Basona Werana district are beneficiaries of the Productive Safety Nets Program (PSNP), which is the major food security program of the government (Alemayehu and Bewket 2017b).

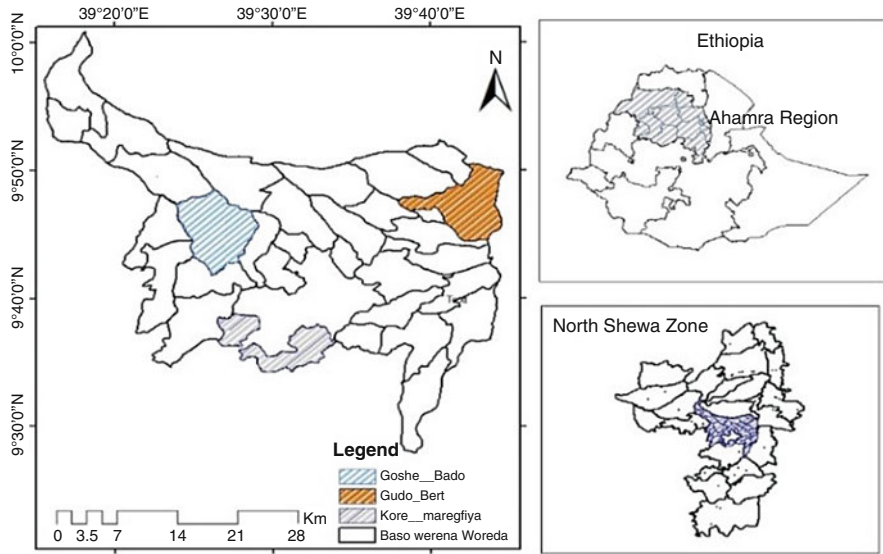
Adaptation enables farmers to reduce vulnerability to adverse effect of climate change and variability. It helps rural communities cope with and adjust adverse consequences to climate change and variability (Deressa et al. 2010; IPCC 2014).

Degefa (2002), Frehiwot (2007), and Messay (2010) investigated the socioeconomic impacts of food security in different regions of Ethiopia. However, the impact of climate change and variability on food security is not addressed in their respective study areas.

Kahsay and Gebremicale (2018) investigated the impact of climate change on household food availability in Tigray region. The findings show that high prevalence of food insecurity has greater consequence among the female households. There are studies addressing the vulnerability context and impacts of climate change covering the central highlands of Ethiopia, which is also part of the present study (Bewket 2009; Alemayehu and Bewket 2016a, b, 2017a, b). This chapter links climate change and variability and food security in Basona Werana district by taking three agro ecological zones. This household level assessment is useful to identify and prioritize food insecure areas and contribute factors for adaptation planning.

Three kebeles (the lowest administrative level in the country) incorporating Kolla (lowland), Weyna Dega (midland), and Dega (highland) agro ecological zones were selected purposively to capture variations in agro ecology (Fig. 1). A total of 123 farmers were selected randomly (53 in Goshebado, 40 in Gudobert, and 30 in Kore Margfiya, respectively). Focus group discussions and key





**Fig. 1** Location of Basona Werana district, central highlands of Ethiopia

informant interviews were conductive to supplement the quantitative results from the household survey.

The monthly rainfall data used for this study are for 56 points (each representing areas of 10 × 10 km) for the period between 1983 and 2016. The monthly maximum and minimum temperatures are for the same points and girds, but cover the period from 1981 to 2016. All were collected from the National Meteorological Agency of Ethiopia. Rainfall and temperature data were analyzed using coefficient of variation (CV), standardized rainfall anomalies (SRA), and linear regression (LR).

CV is expressed as a percentage and computed as

$$CV = (\sigma/\mu) \tag{1}$$

where CV is the coefficient of variation

σ = is the standard deviation

μ = is the mean rainfall

CV is used to classify the degree of variability of rainfall events. The different CV classes are less (CV <20%), moderate (20% < CV <30%), and high (CV >30%).

Standardized rainfall anomalies are calculated to examine the nature of the trends and determines of the dry and wet years in the period of observation as well as frequency and severity of droughts (Agnew and Chappel 1999; Bewket and Conway 2007).

As shown in Agnew and Chappel (1999), SRA is given as

$$SRA = (Pt - Pm)/\sigma \tag{2}$$

where SRA = standardized rainfall anomaly

Pt = annual rainfall in year t

Pm = is long-term mean annual rainfall over a period of observation and

$\sigma$  = standard deviation of annual Rainfall over the period of observation

The different drought severity classes are calculated as shown in Agnew and Chappel (1999): extreme drought ( $SRA < -1.65$ ), severe drought ( $-1.28 > SRA > -1.65$ ), moderate drought ( $-0.84 > SRA > -1.28$ ), and no drought ( $SRA > -0.84$ ).

Linear regression was used to detect changes or trends in rainfall and temperatures. It is given as

$$Y = mx + b \quad (3)$$

where y is dependent variable, m is the slope, x is independent variable, and b is the intercept.

Surface data were generated from 56 points of gridded monthly rainfall and temperature data (10 km  $\times$  10 km) using simple kriging interpolation technique with ArcGIS 10.5.

Household Food Balance Model (HFBM) (sheet) was used to analyses the status of household food security of the sample households in order to classify the households as food secure and insecure (Mesay 2010; Derara and Degfa 2016)

$$NGA = (GP_i + GB_i + GR_i + GPS_i) - (HL_i + GU_i + GS_i + GV_i + NS_i) \quad (4)$$

where

NGA = Net grain available (quintal/household/year); a quintal = 100Kgs

GP<sub>i</sub> = Total grain production (quintal/household/year)

GB<sub>i</sub> = Total grain bought (quintal/household/year)

GS<sub>i</sub> = Total grain obtained through gift or remittance (quintal/household/year)

GPS<sub>i</sub> = Total grain obtained from previous year (stock/year/household)

HL<sub>i</sub> = Post-harvest losses due to grain pests, disasters, thievery (quintal/household/year)

GU<sub>i</sub> = Quantity of grain reserved for seed (quintal/household/year)

MO<sub>i</sub> = Amount of marketed output (quintal/household/year)

GV<sub>i</sub> = Grain given to others within a year (quintal/household/year)

NS<sub>i</sub> = Grain planned to be left by a household for next season (quintal/household/year)

Descriptive statistical methods such as frequencies, means, and percentages were used to summarize the information on food security issues and climate change perceptions, impacts, and adaptation strategies. Chi-square test is used to test the statistical significance of variations across AEZs.

## Impact of Climate Change and Variability on Food Security of Rural Household

### Variability and Trends in Rainfall and Temperature

As shown in Table 1, the average annual rainfall of the area for the study period is 1013 mm, with standard deviation of 125 mm and CV of 12%. Annual rainfall varies from 784 mm (2011) to 1227.2 mm (1985). The results of trend analysis of annual and seasonal rainfall are presented in Table 1. Accordingly, annual and seasonal rainfalls show statistically significant decreasing trends except Bega (October–February) rainfall where there is no clear trend. Annual rainfall shows statistically significant decreasing trend 63.58 mm/decade at  $p = 0.05$  level. Belg rainfall also showed statistically significant decreasing trend at  $p = 0.05$  level. Result supports previous studies by Williams et al. (2012) and Kebede (2013) who reported declining trends in Belg rainfall. Kiremt rainfall has shown statistically significant decline of 23.2 mm/decade. Elsewhere in Ethiopia, Kiremt rains support the main cropping season locally known as Meher at  $p = 0.1$  level. The declining trends of Kiremt rainfall will aggravate the food security challenges in the area.

The coefficient of variation revealed that rainfall in the area has low inter-annual variability (12%) (Table 1). June to Kiremt rainfall has large contribution to annual rainfall (72%), with CV of 13%. Belg and Bega seasons have high rainfall variability each having CV of 42.6% and 56.8%, respectively. Belg rainfall contributed 17% of annual rainfall.

Rainfall distribution was highly concentrated in the few months of the year (July to September). July and August are the wettest months. July has the highest monthly rainfall (295 mm) which contributes 30% of annual rainfall. August has 287.5 mm rainfall and contributes about 29%. November and December are the driest months, having 11 mm of rainfall each (Fig. 2).

Analysis of the standard rainfall anomaly is used to show the intensity and frequency of drought and inter-annual variation at various spatiotemporal scales. The rainfall pattern showed a characteristic that a dry year is followed by another 2 or 3 dry years and vis-à-vis for the wet years.

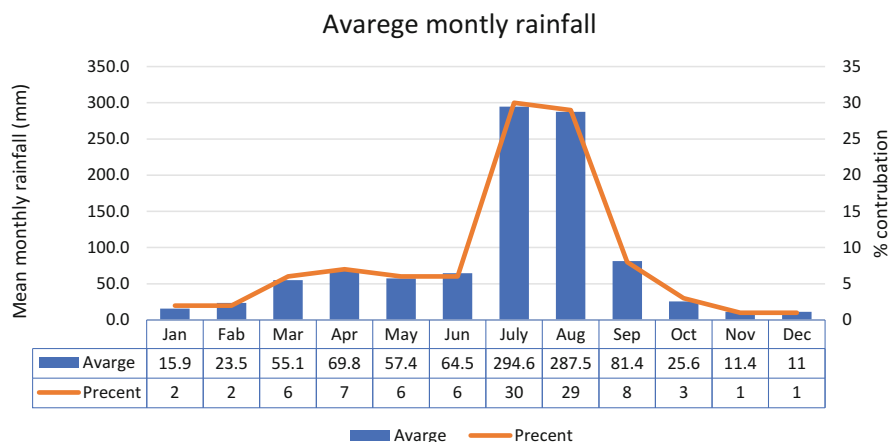
**Table 1** Trends of annual and seasonal rainfall

	Mean	LR	Wettest year	Amount rainfall (mm)	Driest year	Amount rain fall (mm)	SD	CV
Annual	1013	-63.58 <sup>a</sup>	1985	1227.2	2011	783.8	124.4	12.3
<i>Kiremt</i>	733.8	-23.2 <sup>b</sup>	1997	918.9	1987	485.3	98.6	13.4
<i>Belg</i>	182.4	-24.8 <sup>a</sup>	1987	437.1	1998	58	77.7	42.6
<i>Bega</i>	87.5	-11.6	1997	237.2	2011	13.3	49.7	56.8

LR = linear trends (mm 10/year)

<sup>a</sup>Significant at 0.05 level

<sup>b</sup>Significant at 0.1 level

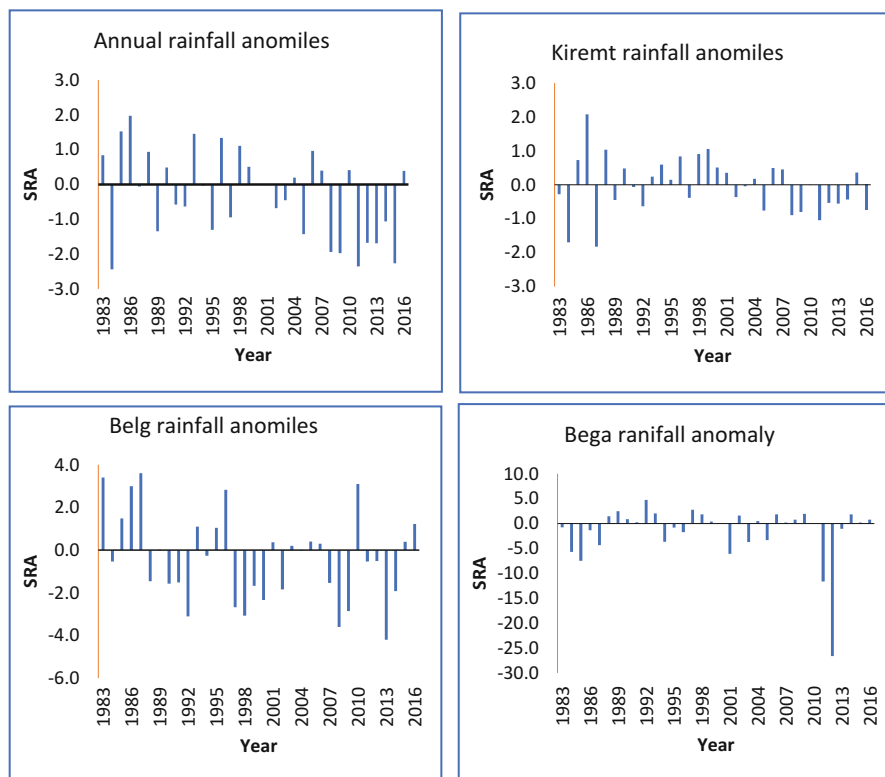


**Fig. 2** Monthly rainfall (in mm) and contribution to the annual total (in %)

After the 1984 drought, annual rainfall showed some recovery, but with considerable internal variations. Extreme drought ( $< -1.65$ ) is observed during the years 1984, 2008, 2009, 2011, and 2015. Severe drought ( $-1.28$  to  $-1.65$ ) is observed for the years 1989, 1995, and 2005 (Fig. 3). The years 2006 and 2007 show positive anomalies. The year 2006 was a major flood year in the country, which caused loss of life and property in different parts of the country particularly in Dire Dawa and South Omo (Alemayehu and Bewket 2017a). The proportions of negative and positive anomalies account for 61% and 39% of the total observations, respectively. The 1980s and 1990s are wet compared with the 2000s. Close to 23% of observations fall under different drought categories.

As shown in Fig. 3, negative and positive Kiremt rainfall anomalies account for 52% and 48% of observations for the period 1983–2016, respectively. Extreme drought was observed in the years 1984 and 1987 and severity drought in 2008 and 2011. Belg rainfall positive anomalies account for 42% of total observation. The extreme drought is observed in 1992, 1997, 1998, 2008, 2009, 2013, and 2014. Belg rainfall anomalies are relatively more positive in the driest decade of the 1980s than the others. Generally, the findings repeat the earlier works of Bewket and Conway (2007), Rosell (2011), Ayalew et al. (2012), and Alemayehu and Bewket (2017a) who reported a similar finding for the central highlands of Ethiopia.

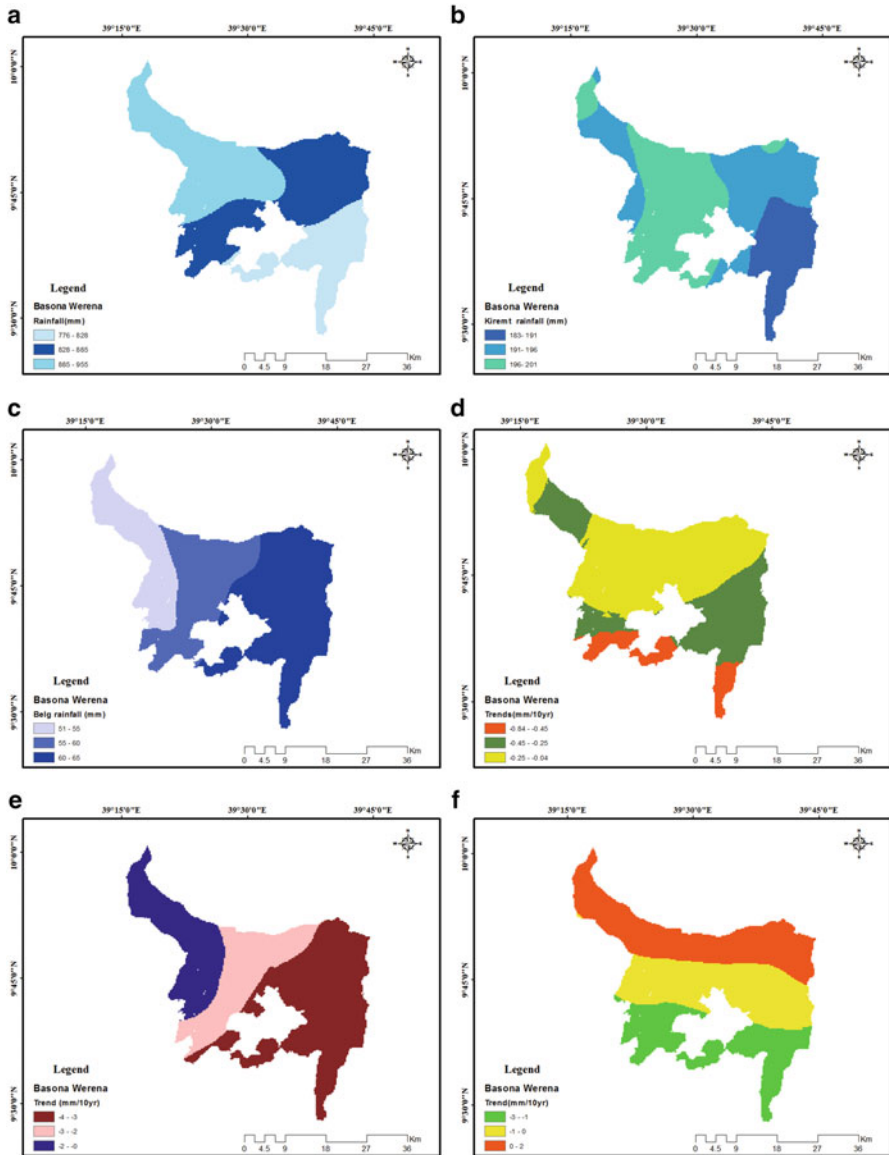
Figure 4 shows the spatial distribution of annual and seasonal rainfall distribution and trends over the period of analysis. Large proportion of the district (42%) receives annual rainfall of between 829 and 886 mm. About 35% of the area in the southern part of the district receives rainfall of between 77 and 829 mm. Close to 33% of the area in the northwestern part receives rainfall of between 886 and 955 mm. Most of the grid points of annual rainfall trend fall within  $-0.84$  and  $-0.04$  ranges. Result coincides with a previous study by Alemayehu and Bewket (2017a) on local scale variability, and trends of rainfall and temperature in the central highlands of Ethiopia that reported most of the grid points fall within  $-0.1$  and  $-0.7$  range which



**Fig. 3** Temporal variations in the annual and seasonal rainfall anomalies

exhibit strong negative trend of annual rainfall. The implication is that drying trends in the district have adverse consequences on the already poor performance of the agricultural sector in the area. Drying trend of Belg rainfall ( $-0.4$  to  $-0.02$ ) in the area is observed. The implication is on the Belg season production, which is important for household level food security in the locality (Alemayehu and Bewket 2017a). In the case of Kiremt rainfall ( $-3$  to  $2$ ) trends in the upper part of the district is observed. In the middle part of the district ( $0$  to  $2$ ), positive trends were observed, whereas the lower part of the district negative trends ( $-3$  to  $-1$ ).

The mean annual temperature is  $13.2$  °C. The lowest and highest mean annual temperatures are experienced in 1999 and 2009, respectively. The lowest temperature is  $12.1$  °C and highest temperature  $14.5$  °C with a standard deviation of  $0.46$  and coefficient variation of  $0.03$ . The lowest temperature is  $-2.1$  °C (December) with a standard deviation of  $0.8$  and coefficient variation of  $0.12$ . The highest temperature is  $24.4$  °C (February) with a standard deviation of  $0.42$  and coefficient variation of  $0.02$ . The mean annual minimum temperature ranges from  $4.83$  °C (2000) to  $-2.1$  °C (1998), and the long-term mean is  $6.3$  °C. The mean annual maximum temperature ranges from  $23.4$  °C (2009) to  $15.8$  °C (1994), and the long-term mean is  $19.7$  °C.



**Fig. 4** Spatial distribution of annual rainfall and seasonal rainfall (A, B, C) and annual rainfall and seasonal trends (D, E, F)

The mean annual maximum temperature shows warming trends for the period 1983–2016. The warming trend in the maximum temperature (0.2 °C/decade) is statistically significant at  $p = 0.05$  level.

As show in Table 2, Bega and Belg season’s maximum temperature experienced statistically significant increasing trends at  $p = 0.05$  and 0.1 levels, respectively.

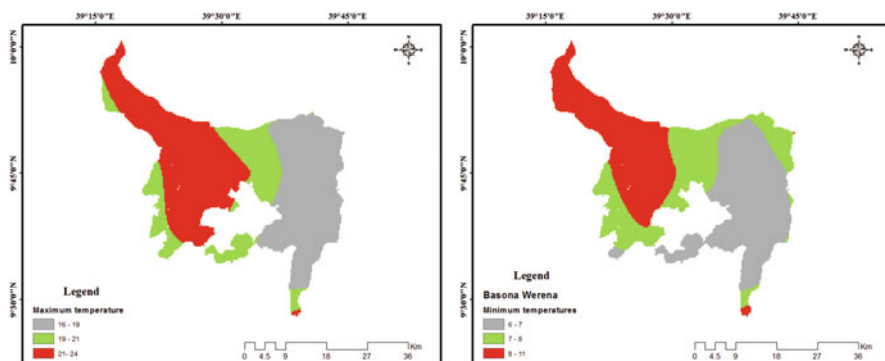
**Table 2** Annual and seasonal trends in the mean maximum and minimum temperature

	Mean maximum and minimum temperature °C							
	Annual	LT	Kiremt	LT	Bleg	LT	Bega	LT
Maximum temperature °C	19.7	0.02 <sup>a</sup>	19.36	-0.1	20.96	0.03 <sup>b</sup>	19.6	0.28 <sup>a</sup>
Minimum Temperature °C	6.29	0.42 <sup>a</sup>	8	-0.015	7.27	0.0114 <sup>b</sup>	3.61	0.013

LR = linear trends (0°/10 year)

<sup>a</sup>Significant at 0.05 level

<sup>b</sup>Significant at 0.1 level

**Fig. 5** Spatial distribution of mean maximum (left) and minimum temperatures (right)

Kiremt season's maximum temperature experienced statistically nonsignificant decreasing trend.

The annual minimum temperature shows positive trend. Minimum temperature has experienced statistically significant increasing trend at  $p = 0.01$  level. Kiremt minimum temperature shows declining trend at  $p = 0.05$  level. The trends for the Bega and Belg minimum temperatures are similar with the maximum temperature; statistically significant increasing trends at  $p = 0.05$  and  $0.1$  levels, respectively, are observed (Table 2). Earlier studies by Conway et al. (2004), NMA (2007), Jury and Funk (2012), Tesso et al. (2012), and Taye and Zewdu (2012) also reported a warming trend of the minimum temperature in their respective study areas and periods.

Figure 5 shows the spatial distribution of mean maximum and minimum temperatures. Both mean maximum and minimum temperatures are higher in the north-western part of the district and decrease in the southeast. The maximum temperature for northern parts of district ranges from 22 °C to 24 °C and the lowest southeast 10–20 °C, whereas the minimum temperature of the district is lowest in the southeast ranging from 6 °C to 7 °C in the study period.

## Rural Household Perceptions of Climate Change and Variability and Their Impacts

Table 3 shows that about 88% of farmers perceived that the climate has been changed. Close to 94% of households in the Kolla agro ecological zone perceived that they have been experiencing climate change and variability. This is followed by Dega agro ecological zone where 93% of households perceived climate change and variability.

A key informant from Dega agro ecological zone explains: in the last three decades, Belg rains are highly variable and shows declining trends in the surrounding. Belg rains now are non-existent become history to the area. The worst case is that Kiremt rainfall is insufficient due to increasing water demand. Kiremt rainfall starts late and ends early. Coupled with other environmental changes like land degradation and soil erosion, current climate variability challenges food security; not capable of producing enough food for family members.

Results from FGDs also confirmed that rainfall is declining from time to time while temperature is getting warmer. About 67% of households in all agro ecological zones perceived that temperature shows warming trend, while 20% of households perceived that temperature shows declining trends in their locality. Close to 13% of households report no observable change of temperature. Statistically significant mean difference was observed in terms of perception of temperature across agro ecological zones at  $p = 0.1$  level.

Regarding changes in rainfall patterns, close to 59% of households reported that rainfall shows decreasing trends. The other 35% of households observed changes in the timing of rainfall. Farmers in the Kolla agro ecological zone reported declining trends in rainfall (73% of households). About 53% and 52% of households from

**Table 3** Rural household perceptions of climate change and variability and their impacts

Climate change/variability	Agro ecological zone			Mean	X <sup>2</sup>
	Dega	Kolla	Weyna Dega		
Yes	93	94	70	88	11.819 <sup>a</sup>
No	8	6	30	12	
Temperature pattern					
Increased	65	71	64	67	8.323 <sup>b</sup>
Decreased	27	20	11	20	
No observable change	8	9	25	13	
Rainfall perceived					
Decrease in rainfall amount	52	73	53	59	5.111
Change in timing of rain	43	24	37	35	
No change in rainfall	5	3	11	6	

<sup>a</sup>Significant at 0.05 level

<sup>b</sup>Significant at 0.1 level



Weyena Dega and Dega agro ecological zone perceived declining of rainfall trends, respectively.

Rural households' perception of changes in rainfall and temperature corroborates the results of metrological data analysis. They perceived reduced rainfall and warming temperatures. Analysis of climate data revealed declining trends of annual and seasonal rainfalls. Similarly, warming of the minimum and maximum temperatures is observed from analysis of climate data.

Regarding the cause of climate change, about 39% of households reported human interventions caused climate change. Close to 11% of households in the three agro ecological zones reported natural factors caused climate change. About 40% and 36% of households in the Dega and Kolla agro ecological zones attributed climate change with religious factors. Statistically significant mean difference was observed in terms of perceived causes of climate change across agro ecological zones at  $p = 0.01$  level. Results of FGD participants and KIIs reported the effect of deforestation for different purposes is the main cause of climate change.

## Impacts of Climate Change and Variability on Food Security of Rural Households

As show in Table 4, majority of the households (88%) reported changes in rainfall pattern as the main challenge of their livelihoods. The onset and offset periods of rainfall are unpredictable and affect sowing and harvesting periods. Prevalence of pest and diseases was mentioned by 82% of the households. The effect of flood is reported by 48% of the households. Snow as a challenge to food security is reported by 65% of the households. For example, months from October to December are the coldest months in the area. Thus, matured crops are more likely to be affected by frost. Drought has several negative consequences in the area; it causes extensive damages to crops and loss of agricultural production. Close to 67% of the households replied that drought was the major climate-related factor challenging agricultural productivity in the area (Table 4).

**Table 4** Impact of climate change and variability on livelihood

Major climate elements	Agro ecological zone			Mean	$\chi^2$
	Dega	Kolla	Weyna Dega		
Temperature increased	79	96	87	87	6.906 <sup>a</sup>
Change in rainfall	79	97	87	88	4.758
Drought	58	73	67	66	9.883 <sup>b</sup>
Flood	58	34	50	48	2.189
Snow	60	71	63	65	1.361
Pests and diseases	88	76	83	82	10.182 <sup>b</sup>

<sup>a</sup>Significant at 0.05 level

<sup>b</sup>Significant 0.01 level

**Table 5** Correlation between climate change and variability and food security

		Temperature change	Rainfall variability	Flood	Drought	Frost
Food security	Pearson Correlation	-0.182	-0.157	0.231	-0.150	-0.174
	Sig.(2-tailed)	0.044	0.083	0.010	0.098	0.055
	N	123	123	123	123	123

Statistically significant mean difference was observed in terms of perceived impacts of climate change and variability on livelihoods across agro ecological zones.

Bivariate correlation was used to analyze the association between food security and climate change and variability over the last two to three decades. The food security status of a household is determined by the rate of temperature and rainfall changes, occurrence of flood, drought, and frost which have adverse negative impacts on crop and animal productivity thereby affecting the food security status of rural households (Table 5).

Results of the bivariate correlation showed that food security has negative correlation with temperature change at  $p = 0.05$  level. Similarly, rainfall variability and occurrence of drought and frost have negative correlations at  $p = 0.1$  levels. Food security has positive correlation with occurrence of flood at  $p = 0.05$  level.

## Household Food Security Status

HFBM was used to determine household food security status. The result of the HFBM reveals that 62% of households are food insecure and failed to satisfy their daily minimum requirement recommended for their households (2100 Kcal/adul. equ), while 38% of the households are food secured. At agro ecological zone level, food insecurity is highest in the Dega (67% of the households) followed by Kolla (60% of the households), whereas majority of food secured households are found in Weyna Dega agro ecological zone (43% of the households). This is because of the fact that topographic and climate factors are conducive for crop production in the Weyna Dega agro ecological zone compared to others (Alemayehu and Bewket 2016b).

There are different constraints that hinder agricultural productivity and then induce food insecurity. As shown in Table 6, almost all households (99%) replied that poor soil fertility was the main factor reducing productivity thereby causing food insecurity. This is followed by climate variability (97% of the households). About 95% and 93% of the households reflected that farmland shortage and low non-farm income are among the major causes for food insecurity, respectively. Farmers felt that insect, pests, and weeds caused food insecurity. Statistically significant variation in terms of agro ecological zone is observed among the causes of food insecurity at  $P = 0.01$  level.

**Table 6** Cause of food insecurity

Cause of food insecurity	Agro ecological zone			Mean	X <sup>2</sup>
	Dega	Kolla	Weyna Dega		
Traditional farm practices	98	98	96	97	1.230
Land fragmentation	100	83	63	82	16.962 <sup>a</sup>
Shortage of labor	95	76	90	87	7.641 <sup>b</sup>
Poor soil fertility	100	96	100	99	2.685
Climate variability(rainfall and temperature)	100	90	100	97	6.884 <sup>b</sup>
Prevalence of animal disease	70	88	67	75	5.175 <sup>c</sup>
Deforestation	97	77	73	82	9.111 <sup>b</sup>
Farm land shortage	100	98	88	95	8.948 <sup>b</sup>
Drought	85	57	60	67	9.065 <sup>b</sup>
Poor access credit	88	66	37	64	6.701 <sup>c</sup>
Low non in farm income	89	97	93	93	3.613
Shortage of grazing land	88	72	90	83	5.719 <sup>b</sup>
Low access market	57	80	40	59	11.936 <sup>a</sup>

<sup>a</sup>Significant 0.01 level

<sup>b</sup>Significant at 0.05 level

<sup>c</sup>Significant at 0.1 level

Shortage of labor, climate variability, deforestation, farm land shortage, and shortage of grazing land as cause of food insecurity show statistical difference across agro ecological zone at  $p = 0.05$  level. While lack of credit access and prevalence of animal diseases show significant difference at  $p = 0.1$  level. The office of Agriculture and Natural Resources of the Amhara Regional State reported that about 15–26% of post-harvest production loss was observed. Coupled with the already low production, the post-harvest loss further affected household food security through diminishing the amount of available food reserve.

This result supported a previous study by Tilaye (2004) in Amhara Region of Ethiopia which identified different factors that cause food insecurity by deteriorating the food production capacity of households. These included drought, soil erosion, land fragmentation, population and pressure poor farming technology, and high labor wage as major causes of food insecurity.

In response, households used different coping and adaptation strategies to mitigate the adverse effects of climate change and variability on food security. About nine types of adaptation measures are identified. These are soil and water conservation, changing planting date, use of fertilizer, planting tree, animal fattening, livelihood diversification, irrigation, improved seed, and crop diversification. The majority of farmers (99%) used soil and water conservation practices as adaptation to the impact climate change variability on food security. This is followed by changing crop planting dates (98% of households). While the least strategies are

irrigation (21%) and animal fattening (59%). Similarly, changing consumption pattern and sell of livestock product (butter, milk, and cheese) are the dominant coping strategies used by 88% and 83% of the households, respectively. While migration and purchase of food by credit are the least coping strategies used by 21% and 37% of the households, respectively.

---

## References

- Adem M, Tadele E, Mossie H, Ayenalem M (2018) Income diversification and food security situation in Ethiopia: a review study. *Food Sci Technol* 4:1–17
- Agnew C, Chappel A (1999) Drought in the Sahel. *Geo J* 48:299–311
- Akinseye F, Ajayi V, Oladitan T (2013) Assessing the impacts of climate variability on crop yield over Sudano-Sahelian zone in Nigeria. *Int J Agric Sci* 1(7):91–98
- Alemayehu A, Bewket W (2016a) Local climate variability and crop production in the central highlands of Ethiopia. *Environ Dev* 19:36–48
- Alemayehu A, Bewket W (2016b) Vulnerability of smallholder farmers' to climate change and variability in the central highlands of Ethiopia. *Ethiopian Journal of the Social Sciences and Humanities* 12(2):1–24
- Alemayehu A, Bewket W (2017a) Smallholder farmers' coping and adaptation strategies to climate change and variability in the central highlands of Ethiopia. *Local Environ* 22(7):825–839
- Alemayehu A, Bewket W (2017b) Determinants of smallholder farmers' choice of coping and adaptation strategies to climate change and variability in the central highlands of Ethiopia. *Environ Dev* 24:77–85
- Alemayehu A, Bewket W (2017c) Local spatiotemporal variability and trends in rainfall and temperature in the central highlands of Ethiopia. *Geogr Ann Ser B* 99(2):85–101
- Alemu T, Mengistu A (2019) Impacts of climate change on food security and its adaptation and mitigation options in Ethiopia: a review. In: *International conference on impact of El Niño on biodiversity, agriculture, and food security*, 23–24 February 2017 Haramaya University, Ethiopia, p 75
- Asfaw A, Simane B, Hassen A, Bantider A (2017) Determinants of non-farm livelihood diversification: evidence from rain fed-dependent smallholder farmers in northcentral Ethiopia (Woleka sub-basin). *Dev Stud Res* 4(1):22–36
- Ayalew D, Tesfaye K, Mamo G, Yitafaru B, Bayu W (2012) Variability of rainfall and its current trend in Amhara region, Ethiopia. *Afr J Agric Res* 7(10):1475–1486
- Belay A, Recha J, Woldeamanuel T, Morton (2017) Smallholder farmers' adaptation to climate change and determinants of their adaptation decisions in the Central Rift Valley of Ethiopia. *Agric Food Secur* 6(1):24
- Bewket W (2009) Rainfall variability and crop production in Ethiopia: case study in the Amhara region. In: Ege S, Aspen H, Teferra B, Bekele S (eds) *Proceedings of the 16th international conference of Ethiopian studies*. Norwegian University of Science and Technology, Trondheim, Norway
- Bewket W, Conway D (2007) A note on the temporal and spatial variability of rainfall in the drought-prone Amhara region of Ethiopia. *Int J Climatol* 27:1467–1477
- Conway D, Mould C, Bewket W (2004) Over one century of rainfall and temperature observations in Addis Ababa. *Ethiop Int J Climatol* 24:77–91
- Degefa T (2002) Household seasonal food insecurity in Oromiya Zone, Ethiopia: S.S research report series no 26, OSSREA, A.A

- Derara F, Degfa T (2016) Household food security situation in Central Oromia, Ethiopia: a case study from Becho Wereda in Southwest Shewa Zone. *Glob J Hum Soc Sci Res* 16 (2):1–16
- Deressa T, Hassan R, Tekie A, Mahmud Y, Ringler C (2010) Analyzing the determinants of farmers choice of adaptation methods and perceptions of climate change in the Nile Basin of Ethiopia. Sustainable solutions for ending hunger and poverty. IFPRI discussion paper 00798. IFPRI, Washington DC
- Frehiwot F (2007) Food insecurity and its determinants in rural households in Amhara Region. Msc thesis, Department of Economics, Faculty of Business and Economics, School of Graduate Studies, Addis Ababa University, Ethiopia
- Hagos A, Dibaba R, Bekele A, Alemu D (2019) Determinants of Market Participation among Smallholder Mango Producers in Assosa Zone of Benishangul Gumuz Region in Ethiopia. *Int J Fruit Sci* 20(3): 323–349
- Intergovernmental Panel on Climate Change (IPCC) (2014) Climate change: the scientific basis: contribution of working group I to the third assessment report. Cambridge University Press, Cambridge
- Jury R, Funk C (2012) Climatic trends over Ethiopia: regional signals and drivers. *Int J Climatol*. <http://onlinelibrary.wiley.com/doi/10.1002/joc.3560>
- Kahsay S, Gebremicale D (2018) Impact of climate variability on food availability in Tigray, Ethiopia. *J Agric Food Secur* 7(6):1–9
- Kebede G (2013) Spatial and temporal uncertainty of rainfall in arid and semi-arid areas of Ethiopia. *Sci Technol Arts Res J* 2(4):106–113
- Markos E (1997) Demographic responses to ecological degradation and food insecurity: drought prone areas in northern Ethiopia. Amsterdam. Thesis Publishers Ph.D. dissertation
- Mesay M (2010) Food security attainment role of urban agriculture: a case study from Adama Town, Central Ethiopia. *J Sustain Dev Afr* 12(3):223–250
- Mesike S, Esekhide T (2014) Rainfall variability and rubber production in Nigeria. *Afr J Environ Sci Technol* 8(1):54–57
- Mongi H, Majule E, Lyimo G (2010) Vulnerability and adaptation of rain fed agriculture to climate change and variability in semi-arid Tanzania. *Afr J Environ Sci Technol* 4(6)
- National Meteorological Agency (NMA) (2007) Climate change: National Adaptation Program of Action (NAPA) of Ethiopia. Ministry of Water Resources, Addis Ababa
- Rosell S (2011) Regional perspective on rainfall change and variability in the central highlands of Ethiopia, 1978–2007. *Appl Geogr* 31:329–338
- Schmidhuber J, Tubiello F (2007) Global food security under climate change. *Proc Natl Acad Sci* 104(50):19703–19708
- Suryabhagavan K (2017) GIS-based climate variability and drought characterization in Ethiopia over three decades. *Weather Clim Extrem* 15:11–23
- Taye M, Zewdu F (2012) Spatio-temporal variability and trend of rainfall and temperature in Western Amhara, Ethiopia: a GIS approach. *Glo Adv Res J Geogr Reg Plann* 1(4):65–82
- Tesso G, Emanu B, Ketema M (2012) A time series analysis of climate variability and its impacts on food production in North Shewa zone in Ethiopia. *Afr Crop Sci J* 20(2):261–274
- Tilaye T (2004) Food insecurity: extent, determinants and household coping mechanisms in Gera Keya Woreda, Amhara region. MA thesis, Addis Ababa University
- Williams P, Funk C, Michaelsen J, Rauscher S, Robertson I, Wils T, Koprowski M, Eshetu Z, Loader N (2012) Recent summer precipitation trends in the greater horn of Africa and the emerging role of Indian Ocean Sea surface temperature. *Clim Dyn* 39:2307–2328. <https://doi.org/10.1007/s00382-011-1222-y>
- Zeleke T, Giorgi F, Diro GT, Zaitchik B (2017) Trend and periodicity of drought over Ethiopia. *Int J Climatol* 37:4733–4748

**Open Access** This chapter is licensed under the terms of the Creative Commons Attribution 4.0 International License (<http://creativecommons.org/licenses/by/4.0/>), which permits use, sharing, adaptation, distribution and reproduction in any medium or format, as long as you give appropriate credit to the original author(s) and the source, provide a link to the Creative Commons license and indicate if changes were made.

The images or other third party material in this chapter are included in the chapter's Creative Commons license, unless indicated otherwise in a credit line to the material. If material is not included in the chapter's Creative Commons license and your intended use is not permitted by statutory regulation or exceeds the permitted use, you will need to obtain permission directly from the copyright holder.





# Intangible and Indirect Costs of Adaptation to Climate Variability Among Maize Farmers: Chirumanzu District, Zimbabwe

# 22

Dumisani Shoko Kori, Joseph Francis, and Jethro Zuwarimwe

## Contents

Introduction: Adaptation, an Overview .....	399
The Cost Associated with Adaptation to Climate Variability .....	399
Location and Climate of Chirumanzu Resettlement Areas and Rationale for Selection .....	401
Characteristics of A1 Maize Farmers in Chirumanzu Resettlement Areas .....	403
Data Gathering .....	404
Data Handling and Analysis .....	404
Adaptation Measures Adopted by Maize Farmers in Resettlement Areas of Chirumanzu .....	405
Changing Planting Dates .....	406
Use of Drought Tolerant Varieties .....	406
Good Crop Establishment Practices (No Regret Measures) .....	407
Conservation Farming .....	407
Wetland Farming .....	407
Diversification .....	408
Problems and Dangers Associated with Adaptation Measures Adopted by Maize Farmers .....	408
Threat to Safety and Wellbeing .....	410
Lack of Mechanical Equipment .....	410
High Cost and Scarcity of Inputs .....	410
Increased Risk and Uncertainty .....	410
Labor Related and Timing Issues .....	411
Negative Effects on Productivity and Profits .....	411

This chapter was previously published non-open access with exclusive rights reserved by the Publisher. It has been changed retrospectively to open access under a CC BY 4.0 license and the copyright holder is “The Author(s)”. For further details, please see the license information at the end of the chapter.

D. S. Kori (✉) · J. Francis · J. Zuwarimwe  
Institute for Rural Development, University of Venda, Thohoyandou, South Africa  
e-mail: [joseph.francis@univen.ac.za](mailto:joseph.francis@univen.ac.za)

Intangible Costs Associated with Adaptation to Climate Variability .....	411
Health, Wellbeing, and Safety Concerns .....	411
Burden on Household Members .....	413
Worry, Anxiety, and Uncertainty .....	415
Pain and Suffering .....	415
Effort Spent to Facilitate Smooth Implementation of Adaptation Measures .....	415
Indecision During Allocation of Scarce Resources .....	415
Ridicule and Embarrassment Associated with Borrowing Equipment .....	416
Indirect Costs of Adaptation to Climate Variability .....	416
Family Labor Opportunity Cost .....	416
Additional and Unplanned Cost of Production .....	417
Yield Losses Related to Risk, Unavoidable Delays, and Timing .....	417
Huge Investment Cost for Some Adaptation Practices .....	418
Conclusion .....	418
References .....	419

## Abstract

Maize farming in resettlement areas of Chirumanzu District of Zimbabwe is vulnerable to climatic variations. The Government of Zimbabwe encourages maize farmers in resettlement areas to adapt to climate variability through conservation farming and diversification among other measures. It is envisaged that the measures will improve maize farmers' resilience and ability to safeguard food and nutrition security in the country. However, the process of adaptation is dynamic, complex, and multifaceted in nature. Several problems and dangers accompany the process of adaptation. The problems and dangers are associated with intangible and indirect costs. The focus of this chapter is to explore intangible and indirect costs associated with measures adopted by maize farmers in resettlement areas of Chirumanzu in Zimbabwe. Fifty-four maize farmers from four resettlement wards provided the data through semi-structured interviews. Diversification, changing planting dates, use of drought tolerant varieties were some of the measures adopted. Several problems and dangers accompanied the adaptation measures adopted. Intangible costs such as pain and suffering, embarrassment, ridicule, and stereotyping were experienced. Indirect costs including additional and unplanned costs were also encountered. This chapter concludes that intangible and indirect costs associated with adaptation may result in reduced adaptive capacity and resilience of maize farmers. Therefore, national governments should exercise extreme caution and desist from only encouraging farmers to adapt. Rather, they should consider intangible and indirect costs involved while providing solutions to reduce them to avoid situations where farmers are worse off while facilitating sustainable adaptation.

## Keywords

Unintended adaptation effects · Nonmarket adaptation costs · Smallholder farming community · Maize farming · Resettlement areas



## Introduction: Adaptation, an Overview

Adaptation is an appropriate way to build resilience to climate variability (Biagini et al. 2014; Costinot et al. 2016; Menike and Arachchi 2016) especially under smallholder maize farming. As such, adaptation has been broadly accepted as a policy priority, which explains why it has received extraordinary attention from politicians (Basset and Fogelman 2013). Following the refusal of some well-developed nations to support the greenhouse gas emission goals of the Kyoto Protocol of 2001, adaptation emerged as the major viable option for furthering the designing of the Climate Change Policy (CCP) (Schipper 2009). The Intergovernmental Panel for Climate Change (IPCC) (2014) states that it recognizes adjustments made even by smallholder farmers in an attempt to reduce vulnerability of farming activities.

Following the agrarian land reforms introduced in 1980 and the Fast Track Land Reform Programme (FTLRP) of 2000 in Zimbabwe, a vulnerable community of farmers emerged in the professed resettlement areas. Since then, the country has been experiencing food insecurity challenges, with almost 50% of the population being vulnerable to hunger due to the combined effect of unsustainable land reforms and extreme climate variations (Sachikonye 2003). As such, concerns about food and nutrition security have seen the Government of Zimbabwe (GoZ) put more emphasis on adaptation. The Zimbabwe National Climate Change Response Strategy of 2015 acknowledges that farmers in resettlement areas are vulnerable to climatic variations that are currently prevailing in the country. Thus, the GoZ is encouraging maize farmers in resettlement areas to adapt to climate variability so that they can improve resilience and ability to fulfill the massive role of safeguarding food and nutrition security.

Major success stories on adaptation to climate variability have been documented around the globe including the African region and in Zimbabwe. Overall, adaptation has improved maize yields by an average of 15–18%, although effectiveness of measures varies significantly across regions (IPCC 2014). Rurinda et al. (2013) showed that improved timing of planting and adjusting soil nutrient inputs stabilize maize yields under variable rainfall conditions in Zimbabwe. However, it is important to note that adaptation is an investment (Adam and Wiredu 2015) associated with costs as the process introduces new ways of doing things thereby calling for some tradeoffs between new and old ways.

---

## The Cost Associated with Adaptation to Climate Variability

The process of adaptation is dynamic, complex, and multifaceted in nature. This is because it occurs in biophysical, technical, social, and psychological dimensions that are not static but evolving. Adaptation initiatives are associated with costs (Arfunuzzaman et al. 2016). The IPCC (2014) confirms and highlights that it is costly to adapt to climate variability especially when resources are scarce and capacity is limited which is the case with most of the maize farmers in resettlement

areas of Chirumanzu District of Zimbabwe. Literature on climate adaptation, in general, does not fully acknowledge intangible and indirect cost of implementing adaptation plans (Milman and Arsano 2014). Yet failure to include the intangible and indirect costs would result in underestimates and misrepresentations of the total cost of adaptation. Adaptation cost literature is still evolving (Fankhauser 2009; Agrawala et al. 2011; Doczi and Ross 2014). It is regarded scant, uncertain, and consensus on overarching cost estimates is lacking (Kumar et al. 2010). There is little peer-reviewed literature on the subject.

Attempts have been made to estimate total adaptation cost. However, adaptation cost estimates only exist at a global level. It is estimated that total adaptation cost ranges from USD9 billion to USD109 billion per year by 2030 (Agrawala et al. 2008; Chambwera et al. 2014). For the agricultural sector, adaptation cost estimates are rare. Agrawala et al. (2011) indicated that with the exception of Mccarl (2007) literature on the cost of adaptation in agriculture is lacking. Mccarl (2007) used a top-down approach to estimate the cost of adaptation in the Agriculture, Forestry, and Fisheries sector. It is estimated that adaptation will cost USD14.23 billion per year by 2030. It is clear that methods that have been used to estimate adaptation costs are quantitative giving much attention to attaching a monetary value to tangible and direct costs. Intangible and indirect costs that do not have a market value are rarely considered.

Agrawala et al. (2008) also observed that there are no accepted metrics for assessing the cost of adaptation measures. As such, multiple definitions for adaptation cost exist. Existing definitions commonly refer to the cost associated with adjustments (Fankhauser 1998) and development initiatives (World Bank 2010) required to reestablish farming conditions prevailing before the occurrence of variations in climate while the IPCC (2014) consider the cost associated with planning, preparing for, facilitating, and implementing adaptation measures in farming practices including transaction costs. The definitions illustrate that there is no consensus as to what constitute adaptation cost. There are various aspects being considered by different authors and organizations. Another challenge is that there is no distinction according to type and/or class of adaptation costs. This makes the issue a complex phenomenon.

In this chapter, some components of the above definitions were adapted. Other considerations mentioned by Smith and Ward (1998) and Meyer et al. (2013) while assessing the costs of natural hazards were also infused. As such, in this chapter, intangible adaptation cost refers to problems and dangers that maize farmers encounter while planning, preparing, and implementing adjustments that cushion the impact of climate variability shocks on maize farming. The problems and dangers are not measurable in monetary terms, as they are not traded on the market as Smith and Ward (1998) illustrated. On the other hand, indirect adaptation cost refers to secondary unintended effects that unfold during implementation of adjustments to cushion the effect of climate variability. The secondary unintended effects include interruptions of normal day-to-day operations, extra demand on available resources such as labor and post adaptation effects that may arise. These may be measurable but not necessarily in monetary terms and are secondary effects of adaptation.

Climate justice scholarship on adaptation raises questions of fairness (Adger et al. 2013; Forsyth 2014). To achieve fairness, intangible and indirect costs arising from

the implementation of adaptation measures especially among social classes within societies should be recognized. This chapter builds on the concept of “fair adaptation” (Adger et al. 2013; Forsyth 2014; Mikulewicz 2017) and draws upon components of distributive and procedural fairness (Graham et al. 2018) to explore intangible and indirect costs arising from the implementation of adaptation measures among farmers in Chirumanzu. Emphasis is on one of the four principles of fair adaptation, “putting the most vulnerable first” in order to ensure equitable outcomes among those at risk (Paavola and Adger 2006). Thus, concern is on redressing existing inequalities and preventing future ones (Graham et al. 2015) through prioritizing vulnerable resettlement farmers in Chirumanzu District of Zimbabwe and other smallholder farmers elsewhere in similar settings.

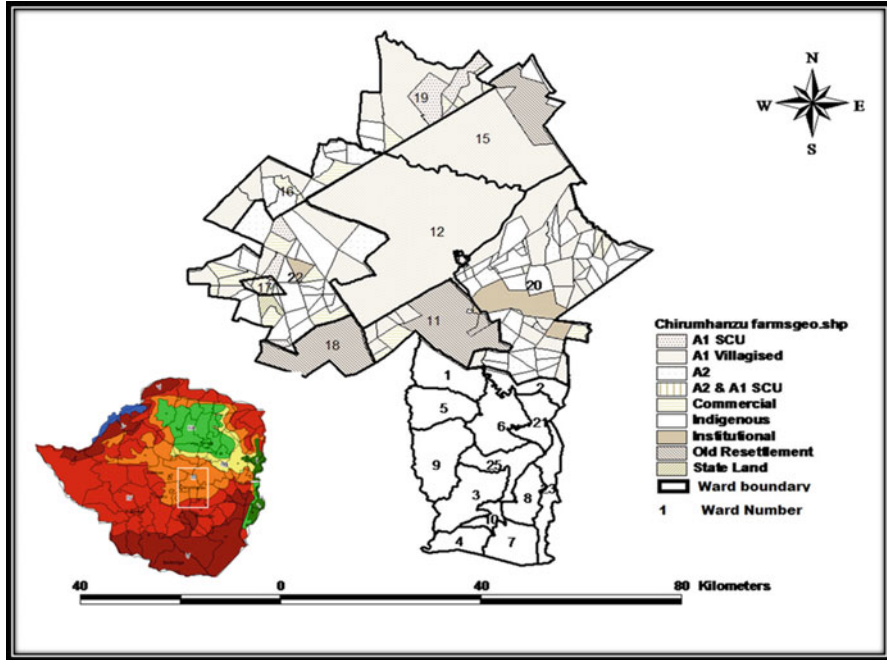
Of particular interest to this chapter is the fact that existing adaptation costs have been largely direct and tangible (Meyer et al. 2013). Apart from that, adaptation cost literature has concentrated on attaching cost figures (Mundial 2006; United Nations Framework Convention on Climate Change (UNFCCC) 2008; World Bank 2010) to existing direct and tangible costs yet there are other costs difficult to measure in quantitative terms. This implies that literature on adaptation cost to date does not fully enhance understanding of the overall picture of the cost associated with adaptation. This problem makes it difficult for smallholder farmers to make sustainable decisions and adopt and maintain adaptation plans apart from diminishing adaptive capacity and resilience. Yet governments, researchers, and international organizations are increasingly encouraging adaptation among smallholder farmers.

This chapter, therefore, responds to the necessity of understanding the intangible and indirect components of the cost of adaptation to climate variability. Intangible and indirect costs associated with adaptation to climate variability for smallholder maize farmers in resettlement areas of Chirumanzu District of Zimbabwe were explored. To achieve this, problems and dangers associated with adaptation measures arising from implementing adaptation plans are established. Subsequently, intangible and indirect aspects are discovered. Three important questions are answered in this chapter: What adaptation measures did maize farmers in resettlement areas of Chirumanzu commonly adopt? What problems and dangers are associated with adaptation measures commonly adopted? What are the intangible and indirect costs associated with the problems and dangers?

---

## **Location and Climate of Chirumanzu Resettlement Areas and Rationale for Selection**

Figure 1 shows the location of Chirumanzu in Zimbabwe and the resettlement areas in the district. The District lies between longitudes 29°50E and 30°45E and latitudes 19°30S and 20°20S. Chirumanzu District is located in the Midlands Province of Zimbabwe. At least 90% of Chirumanzu District lie in Natural Region III while the remainder falls under Natural Region IV (Gwamuri et al. 2012). Natural Region III receive rainfall ranging from 500 to 750 mm, while Natural Region IV receive 400–510 mm per annum (Musara et al. 2011).



**Fig. 1** Map of Chirumanzu District, Zimbabwe showing resettlement areas

Chirumanzu resettlement area experiences extreme weather events in the form of severe mid-season dry spells and frequent seasonal droughts (Simba and Chayangira 2017) yet rain fed agriculture is the major source of livelihood in the area with maize farming being the major farming activity as it is the staple food. Maize farming is largely for consumption. Surplus is often sold providing a source of income for the resettlement farmers. Such a rural setting that is continually battered by climate variations and extreme events presented the need for farmers in the resettlement areas to adapt making them suitable candidates for the study thus presenting a platform for interrogation.

Of the 23 wards in Chirumanzu District, nine (Wards 11, 12, 15, 16, 17, 18, 19, 20, and 22) are predominantly resettlement areas. These resettlement areas were a result of both the old resettlement program in the 1980s and the Fast Track Land Reform Program (FTLRP) of 2000. Farmers were resettled under A1 and A2 models. This chapter focuses on beneficiaries of the A1 model because these are local communities where the effects of climate variability are largely felt as recognized by the IPCC (2014). Model A1 was designed to address poverty and vulnerability for the landless poor. Furthermore, it was expected that by doing so, the congested communal areas would be depopulated resulting in relatively small farms that could sustain families (UNDP 2002).

Model A1 has three settlement schemes namely villagized, self-contained (Njaya and Mazuru 2014), and old resettlement. In the villagized scheme, each farmer is

allocated about one hectare to build homesteads in a village set up. Each resettled farmer got 5–6 hectares away from the village. Grazing area is designated to be communal. In contrast to the villagized scheme, self-contained plots ranging from 15 to 30 hectares are allocated per farmer for both cultivation and grazing. Old resettlement scheme is similar to the villagized scheme in its setup. As Thebe (2018) reveals, A1 farms were established on former ranching farms with varying land quality characterized by poor sandy soils to rich black loams. Chirumanzu resettlement areas lie over four main soil types. These are deep sandy, clay, shallow sodic, and sandy loam. These soil types are more or less similar to those found in most smallholder farming communities across Zimbabwe and Southern Africa. Therefore, the information provided in this chapter is of greater applicability to most smallholder farmers.

To explore the intangible and indirect costs of adaptation, four out of the nine resettlement wards were selected. The enquiry was therefore, conducted in Wards 11, 12, 15, and 20. Dominant soil types and resettlement schemes in Chirumanzu District were considered specifically to capture intangible and indirect adaptation cost experiences of different maize farmers operating under different circumstances. There are four dominant soil types in Chirumanzu resettlement areas and three A1 resettlement schemes. Each ward represented a specific soil type and resettlement scheme.

Wards 11, 12, 15, and 20 represented sandy loam, shallow sodic, clay, and deep sandy soils, respectively. Apart from this consideration, Ward 11 represented the old resettlement scheme and farmers with relatively more farming experience but with relatively small farm sizes. Ward 12 was selected to represent the villagized scheme and farmers with less farming experience with relatively small farm sizes. Ward 15 was selected to represent self-contained scheme and farmers with less farming experience with relatively larger farm sizes. Ward 20 was unique because it has both the A1 villagized and self-contained resettlement schemes. Furthermore, there is need to note that the imbalance in the main soil types and resettlement models justified inclusion of Ward 20 in the investigation.

---

## **Characteristics of A1 Maize Farmers in Chirumanzu Resettlement Areas**

Fifty-four A1 maize farmers were identified from the selected wards so that they could serve as the sources of data through semi-structured interviews. The inclusion and/or exclusion criterion that suited the theme of the investigation was A1 maize farmers who have adapted to climate variability and still had operational adaptation systems in place during the time of the study. Intensive consultation with the District Agricultural Extension Officer and Ward Extension Officers led to the identification of A1 maize farmers who met the inclusion/exclusion criteria.

Out of the 54 farmers, 10 were female. Farmers' age showed skewed outcomes. Forty-three farmers were in the 61–70 and 71–80 age groups with only two being 31–40 years old. Farming experience varied from six to more than 30 years. Thirty-one farmers attained secondary education. Only three farmers had tertiary qualifications. Five farmers did not have any formal education but could read and

write. Most of the farmers were settled during the period 1998 and 2002 implying that they were settled under the FTLRP. All farmers in Ward 11 were settled in the 1980s reflecting that they were settled under the old resettlement scheme. Only seven farmers were settled in the 1990s and beyond 2002. Farmers settled under the Fast Track Land Reform were either under villagized or self-contained schemes. Farm sizes for farmers under A1 old resettlement and A1 villagized schemes were either five or six hectares while those in the self-contained scheme were either 15 or 30 hectares. Thirty-five farmers had at least 6 hectares of arable land while more than 50 farmers had between 3 and 10 hectares of arable land under maize production.

---

## Data Gathering

Semi-structured interviews were conducted with the selected A1 maize farmers. Interviews were conducted in Shona, which is the local vernacular language. This ensured that the respondents had a common understanding of the meaning of the questions compared to the situation had English been used. A semi-structured interview guide with open-ended questions was used to gather data on commonly adopted adaptation measures, associated problems and dangers, as well as the related intangible and indirect costs. Detailed notes of the interviews were taken. Concurrent audio recording of the interview proceedings helped enhance accuracy of farmers' responses.

Data saturation was reached between the 8th and 9th farmer in all the wards. Instead of terminating the interviews, they were continued until the 15th farmer in Wards 11, 12, and 20. This was done in line with the Peterson (2019) advice that seeks to obtain deeper insights. However, in Ward 15 interviews were terminated after interviewing the 9th farmer. An unexpected commotion developed during interviewing, which created hostile conditions that made it impossible to continue with the data collection as originally planned. In total, 54 farmers were interviewed. This final sample was decided on based on the Morse (2016) recommendation that in a grounded theory research such as this one, 30–50 interviews should be conducted. Four additional farmers were included based on the assumption that new and rich data could be generated from them. In addition, Onwuegbuzie and Leech (2007) argue that it is important to ensure that a sample is neither too small to achieve data saturation nor too big to manage.

---

## Data Handling and Analysis

All audio-recorded interviews were first transcribed verbatim. Textual data from audio recordings and notes taken were stored as a MS Excel spreadsheet on a case-based entry as illustrated by Friese (2016). The file was imported into Atlas.ti Version 8. A grounded theory approach was adopted during the thematic content analysis carried out in Atlas.ti Version 8. Inductive thematic content analysis was performed through reading responses given by the farmers. Textual responses were used to develop preliminary codes through inductive coding. It was performed via

open and in vivo coding, in line with the Friese (2016) method. Open coding involved reading the text responses, sentence by sentence while forming detailed and structured themes. In this way, a grounded analysis was guaranteed. Simultaneously, codes and resulting code groups that were drawn from primary data were certified while avoiding missing important data. The same approach was used for in vivo coding. In this case, a word or phrase from textual responses was used to represent a code or code group.

Similar or related codes with the same meanings were merged to avoid unnecessary repetition. Irrelevant codes were deleted. Preliminary codes were grouped and merged into code groups. Groups with preliminary codes that were combined yet reflecting two or more concepts were split. Selective coding was used to create qualitative visual representations of the data in the form of network diagrams. Relationships and patterns were created using the resulting codes and groups linking them with quotations to create network diagrams, which were then exported to MS Word for use in presenting results and research report.

---

## **Adaptation Measures Adopted by Maize Farmers in Resettlement Areas of Chirumanzu**

Maize farmers in resettlement areas of Chirumanzu adopted six common measures to cushion the impact of climate variability shocks on maize farming. The nature of the adaptation measures suggests that maize farmers in resettlement areas commonly adopt autonomous, *ex-post* measures (Smit et al. 2000) in response to climate variability shocks and impacts. The act of adaptation is done after farmers have already experienced significant impact costs. This signifies that adaptation is an act of restoration among maize farmers in Chirumanzu rather than intentional. Farmers adopted measures out of desperation in order to restore the losses incurred due to the impact of climate variability. This corresponds to Shoko et al. (2016) who compared adoption rates and preference of adaptation measures among smallholder farmers and found out that for some measures, adoption rates were low while preference was high and vice versa. It was therefore concluded that often farmers adopt adaptation measures not because they prefer them but out of desperation.

It is noticeable that some measures were highly adopted in some wards than in others possibly due to different characteristics of farmers. Of particular importance to this chapter are the soil types and resettlement schemes. Deviant and exceptional cases, adopted by only a few or even one farmer, were also observed among the measures adopted by maize farmers. Furthermore, some measures were adopted for specific stages in the maize value chain, while some were adopted for more than one production stage. Apart from that, some measures were adopted to address several climatic variations.

In some cases, some of the measures adopted were contradictory, while others ended up disadvantaging farmers leaving them in a worse off situation. It is also important to note that out of the six adaptation measures, female farmers adopted five which is a competitive number. This outcome challenges the binary male-female

view of gender that women are passive victims of climate change (Nellemann et al. 2011) and confirms that women are proactive agents when it comes to climate adaptation (Mitchell et al. 2007; Dankelman 2010). In the following section, the main adaptation measures that maize farmers in resettlement areas of Chirumanzu commonly adopt are described and discussed.

## Changing Planting Dates

Maize farmers in resettlement areas change planting dates in various ways. Farmers either plant early (dry planting), well before the rains start, or late as they are forced to wait for effective rains (sometimes late December or even January). Early and/or dry planting is adopted to address late onset of rains while avoiding delayed planting and falling behind production schedule. Late planting while waiting for effective rains is also normally adopted to address late onset of rains while avoiding poor germination rates and poor crop stand. In some cases, farmers plant their maize crop at different dates of the farming season (staggering). Staggering is adopted to address recurring climate variability shocks and evade total crop failure. Early and late planting are contradictory measures suggesting that adapting to climate variability is not “a one size fits all” approach. Different farmers take different routes depending on background characteristics bringing out farmer heterogeneity.

## Use of Drought Tolerant Varieties

The use of drought tolerant varieties is one of the highly adopted measures in resettlement areas of Chirumanzu. Drought tolerant varieties increases yield in most drought stricken areas by an average of 600 kgs per hectare (Lunduka et al. 2019). Drought tolerant varieties endure moisture stress for a period of six weeks and have high tolerance to dry spells especially during the critical stages of development (Cairns et al. 2013). Due to recurring droughts that are experienced almost every three years in resettlement areas of Chirumanzu, farmers use drought tolerant varieties to improve yields. Drought is one of the limiting factors in rain-fed maize farming especially in sub-Saharan Africa particularly in Zimbabwe (Lunduka et al. 2019). This explains why the use of drought tolerant varieties is one of the highly adopted measures in resettlement areas of Chirumanzu. Common drought tolerant varieties grown by maize farmers in resettlement areas of Chirumanzu are hybrid varieties, SC513 and SC403.

Although at times a considerable proportion of farmers receive drought tolerant varieties from the government, some are always not fortunate enough to get access. As such, despite most of the resettled farmers being resource poor (Mushunje et al. 2003; Chinamatira et al. 2016) and confronted with a variety of challenges in acquiring inputs including hybridized seed, Mkodzongi and Lawrence (2019) opined that resettlement farmers strive to self-finance farming activities. This can be argued to include adaptation investments such as the use of drought tolerant



varieties. In that case, the use of drought tolerant varieties is an act of desperation that farmers implemented in order to restore and or prevent the losses from the impact of climate variability.

### **Good Crop Establishment Practices (No Regret Measures)**

Good crop establishment practices were mainly “no regret measures.” These measures include effective and timeous weeding, timeous application of fertilizers, timeous harvesting, and irrigation. According to Hallegatte (2009), no-regret measures are measures that yield benefits even if climate variability does not occur. Similarly, good crop establishment practices are normal practices conducted during maize farming whether there is climate variability or not. Such measures illustrate manipulative behavior and it is argued that they are a subset of adaptive behavior (Thomsen et al. 2012). Good crop establishment practices such as timeous weeding are an example of measures adopted for specific production stages in the maize value chain. Timeous weeding was adopted solely for weed control stage. On the other hand, irrigation is one of the exceptional cases adopted by only a few farmers in resettlement areas of Chirumanzu.

### **Conservation Farming**

Conservation farming is mainly practiced through the use of planting basins and mulching in resettlement areas of Chirumanzu. These adaptation measures are mainly adopted to conserve moisture while at the same time reducing moisture stress. Planting basins is the use of shallow pits that allow accumulation of water, facilitating rapid infiltration into the soil (Rusinamhonzi 2015). The use of planting basins is highly debated in literature. In Zimbabwe, it is referred to as “*dhiga ufe*” translated as the “dig and die” technology (Andersson et al. 2011) due to the high labor requirements associated with the practice. Mulching is the use of crop residue and/or other organic material to maintain a permanent or semi-permanent soil cover with the intention of conserving soil moisture (Nyamangara et al. 2014). Maize farmers in resettlement areas of Chirumanzu often use grass and old leaves since crop residue is not adequate to cover large areas of land. Conservation farming is common in Ward 11 with sandy loam soils that quickly loses soil moisture due to accelerated drying of sandy loam soils.

### **Wetland Farming**

Maize farmers in Chirumanzu often move from their original farms to the wetland areas due to recurring droughts, mid-season dry spells, unpredictable, and unreliable rains. In these wetlands, they can plant as early as September because the soil has enough moisture to sustain germination. Wetland farming is an irregular measure

that is an unusual feature in existing research. The adaptation measure is also a characteristic of certain places that have wetland areas, for example, Ward 20 of Chirumanzu. Maize farmers in Ward 20 relocated to the wetland areas in the same locality as their original farms. This is not fully consistent with the conservative narrative on disaster-induced migration (Gray and Mueller 2012). The conservative narrative predicts that climate variability consistently increase long-term population mobility and effects are most visible for long distance moves. However, in Chirumanzu Ward 20, effects are most visible for internal moves. It also important to note that wetland farming is a form of maladaptation. According to the IPCC (2014), maladaptation refers to actions that increases the risk of adverse climate-related outcomes, increases vulnerability to climate variability, or diminishes welfare, now or in the future. The concept of maladaptation as Magnan et al. (2016) puts it focuses on the importance of accounting for potential side effects of adaptation to avoid solutions that are worse than the original problem. Moving to the wetland shifts environmental pressures elsewhere and is thus considered a form of maladaptation (Magnan et al. 2016).

## Diversification

Diversification was practiced to avoid the effects of continual decline in maize yield and total crop failure. It is practiced in three different ways. These are crop, enterprise, and income diversification. Farmers grow multiple crops such as small grains, groundnuts that are more resilient to extreme climate variability than maize. Farmers venture into new enterprises like broiler production and look for alternative activities such as gold panning as alternative sources of income than relying on maize alone. Diversification is adopted by farmers with larger farms mostly in the self-contained scheme with more than 15 hectares of land. This illustrate findings by Amare et al. (2018) who projected that farm size has a significant and positive effect on the adoption of diversification to combat climate change impacts.

---

## Problems and Dangers Associated with Adaptation Measures Adopted by Maize Farmers

Maize farmers in resettlement areas of Chirumanzu experienced several problems and dangers while implementing adaptation measures. Figure 2 shows an imported network diagram depicting a visual representation of the problems and dangers associated with adaptation measures adopted by maize farmers. The network diagram displays code groups (key problems and dangers) and codes (associated problems and dangers). Seven code groups and 32 codes were comprehended. This implies that 32 problems and dangers were identified.

Code groups are presented in red boxes on the network diagram and associated codes in white boxes. Associated codes are linked to code groups with arrows showing how they are related to respective code groups.

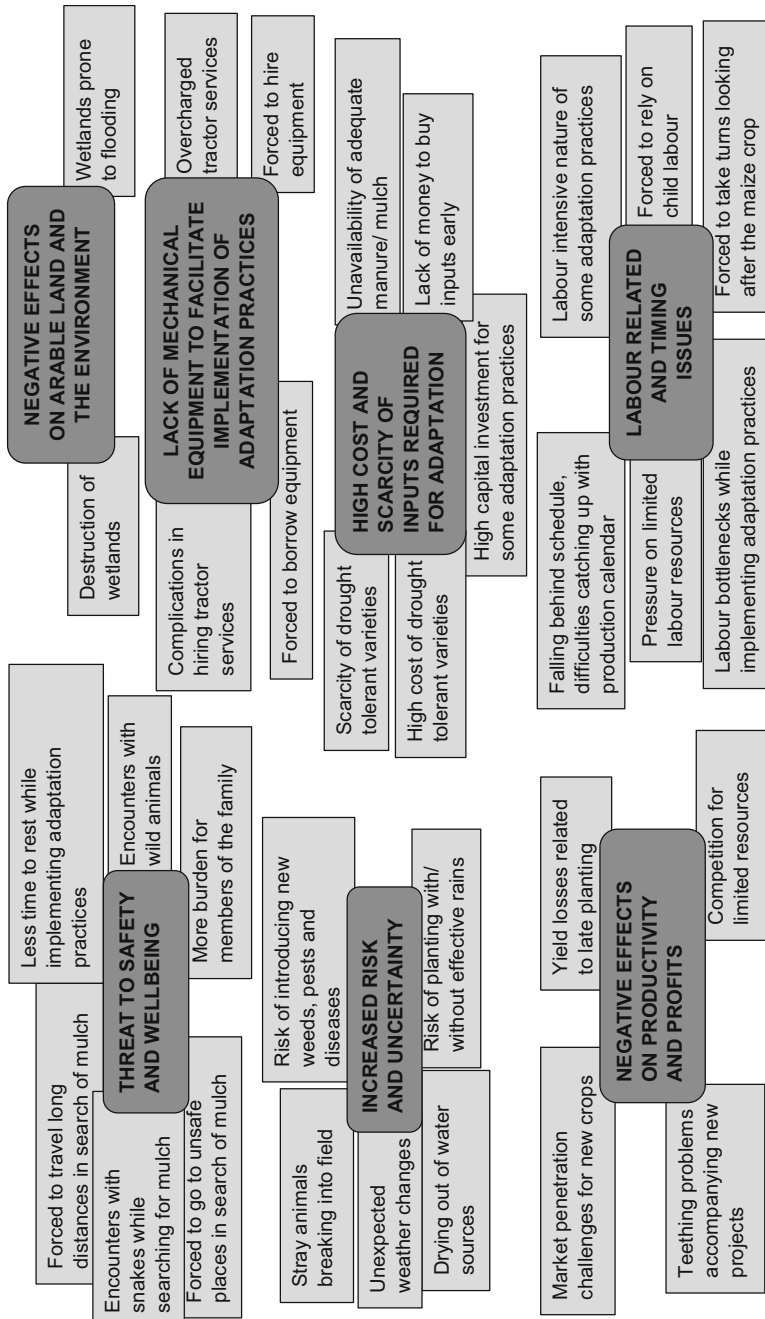


Fig. 2 Network diagram showing problems and dangers associated with adaptation measures adopted by A1 maize farmers

## **Threat to Safety and Wellbeing**

Some of the adaptation measures implemented by maize farmers pose threat to safety and wellbeing of farmers. Tedious and laborious adaptation measures such as conservation farming result in less time to rest. Mulching forces farmers to travel long distances in search of mulch material. Sometimes they were forced to go to unsafe places in search of grass and old leaves which they normally use as mulch material. Encounters with snakes while searching for mulch material are common.

## **Lack of Mechanical Equipment**

Lack of mechanical equipment that facilitates implementation of adaptation practices is a major problem. Implements such as ploughs, picks, spades, and hand hoes are required to facilitate implementation of adaptation plans. However, due to resource constraints, farmers do not always have these tools at hand when needed. Farmers are forced to either borrow or hire equipment to execute adaptation plans. However, there is no guarantee that when they borrow they will get the implements. On the other hand, the process of hiring equipment is complicated and this leads to delays and interruptions in implementing adaptation activities. Tractor services are scarce in the area and a few who have them overcharged the services.

## **High Cost and Scarcity of Inputs**

High cost, scarcity, and continual increase in prices of inputs is also a major problem for farmers while adapting to climate variability. Inputs required to implement or maintain some adaptation practices are not readily available. Where these inputs were found, usually on the black market, they are often charged double the normal price. Scarcity and high cost of inputs hinders farmers from implementing adaptation plans on time.

## **Increased Risk and Uncertainty**

Farmers encounter increased risk and uncertainty while adapting to climate variability. Unexpected weather changes ruin adaptation plans in general. Planting early pose a risk of stray animals breaking into the field since during September when most people in the area start early planting, people will still be sending their cattle away without someone attending to them. Planting without effective rains often leads to poor germination posing the risk of seed rotting and subsequently seed wastage. Irrigation is associated with the risk of drying out of water sources.

---

## **Labor Related and Timing Issues**

Labor related and timing issues is another key problem that farmers encounter during adaptation. Waiting for effective rains results in delayed land preparation subsequently leading to delayed planting. Resultantly, farmers fall behind schedule. Sometimes they plant late December or January. This puts pressure on labor resources as they try to catch up with production calendar. The effectiveness of their work is compromised as they do things hurriedly. Some adaptation measures are labor intensive. The use of planting basins requires a lot of labor. Such measures burden farmers and they end up relying on children to assist. Furthermore, such measures are limited by labor bottlenecks.

## **Negative Effects on Productivity and Profits**

Some adaptation measures call for extra production costs. This threatens the sustainability of maize enterprises. Where they practice wetland farming, they plant as early as mid-September. Farmers will need to buy fence to create a barrier in case stray animals might enter into the field and eat maize while they are not watching. Equally, diversification demands extra investment costs to start new project ventures. Farmers ventured into the production of horticultural crops, broiler production, and production of small grains. However, these production activities present a new set of challenges for farmers. Teething problems are experienced as farmers start these new project ventures. Competition for resources is escalated since there is need to balance the resources for all the activities. Farmers who diversify into small grains face marketing strategies as there is no established market for small grains.

---

## **Intangible Costs Associated with Adaptation to Climate Variability**

Problems and dangers encountered by maize farmers while adapting to climate variability have several intangible costs. Intangible costs do not have a market value therefore cannot be valued in monetary terms. Tables 1 and 2 summarize adaptation measures adopted by maize farmers, associated problems and dangers, as well as the related intangible costs.

## **Health, Wellbeing, and Safety Concerns**

Some adaptation measures threaten farmers' wellbeing raising health and safety concerns. Due to the lack of mulch material, farmers and household members are forced to travel long distances and go to unsafe places in search of adequate and suitable materials. As such, there is less time to rest and exposure to danger due to the risk of encountering snakes. With wetland farming, farmers are forced to take

**Table 1** Intangible and indirect costs associated with adaptation measures adopted by A1 maize farmers

Adaptation measure	Problems and dangers associated with adaptation measures	Associated intangible costs	Associated indirect costs
Conservation farming	Tedious and labor intensive	Reliance on child labor leading to violation of children's rights	Family labor opportunity cost
		Extra burden on members of the family	
	Lack of mechanical equipment	Setbacks in implementing	Loss due to delays
	Forced to borrow equipment	Embarrassment associated with borrowing	–
		Ridicule and stereotyping associated with borrowing	–
		Availability and access of equipment not guaranteed	–
	Forced to hire equipment	Effort put in hiring equipment	Unplanned, additional hiring cost
		Availability of equipment not guaranteed	–
	Complications in hiring equipment	Effort put in negotiating deals	Opportunity cost of lost time negotiating
	Overcharged services for equipment	–	Extra, often unplanned cost
	Lack of mulch material	Setbacks in implementing	–
	Forced to travel long distances	Less time to rest	–
		Wellbeing concerns	–
	Forced go to unsafe places	Encounters with snakes	–
Safety concerns		–	
Possibility of introducing new weeds, pests, and diseases with mulch	–	Yield loss related to the risk of new weeds, pests and diseases	

(continued)

**Table 1** (continued)

Adaptation measure	Problems and dangers associated with adaptation measures	Associated intangible costs	Associated indirect costs
Changing planting dates	Risk of falling behind schedule and difficulties catching up while waiting for effective rains	Worry, anxiety and uncertainty	Yield losses related to timing
		Extra burden	Opportunity cost of labor
	Unexpected weather changes	Pain and suffering due to losses	Yield losses related to unexpected weather changes
	Possibility of replanting associated with dry planting as seed fail to germinate due to insufficient moisture	Pain and suffering due to poor germination	Losses due to seed wastage
		Threatened emotional wellbeing	–
		–	Cost of additional seed for replanting
–	–	Additional labor cost for replanting	
Late planting is associated with yield losses	–	–	Yield loss related to late planting

turns in looking after the maize crop in case stray animals might break into the field and destroy the crops. While looking after the maize crop, they encounter wild animals such as wild pigs and baboons which may attack them.

### Burden on Household Members

Adapting to climate variability exert excessive burden on household members. Conservation farming, for example, is generally labor intensive, tedious, and time consuming. Farmers usually rely on family members particularly children and women to provide the required labor as they cannot afford to hire or contract workers.

As a result, children get to school late, often miss school, and have little time to play as they are expected to help with implementing adaptation activities. The female folk are excessively burdened as farmers implement adaptation activities. Women are forced to disregard other activities such as going to church. Other important activities like tending to the cattle and goats are left to the children.

Looking after and taking care of the home is put on hold or sometimes neglected. Women face difficulties in coping and balancing household and adaptation chores. Household members struggle with abnormal day schedules and unusual working

**Table 2** Intangible and indirect costs associated with adaptation measures adopted by A1 maize farmers

Adaptation measure	Problems and dangers associated with adaptation measures	Associated intangible costs	Associated indirect costs
Use of drought tolerant varieties	High cost of drought tolerant varieties	Effort spent looking for better priced DTVs	Opportunity cost of time
	Scarcity of drought tolerant varieties	Effort spent looking for DTVs	
Good crop establishment practices	Tedious nature of practices such as effective weeding	–	Investment cost for efficient system
	Time consuming	–	–
	High startup costs associated with irrigation	–	Investment cost for irrigation system
	Risk of drying up of water sources	Uncertainty and worry over water source	
Diversification	Capital investment for new project	–	Investment cost for new project
	Teething problems while starting a new project	Pain and suffering as project fail to take up	Losses due to failure of new project
	Competition for resources	Indecision/difficulties allocating resources	–
	Market penetration challenges for new products	Difficulties penetrating the market	–
Wetland farming	Risk of stray animals breaking into field, Need to take turns to look after maize	Taking turns looking after maize, forced to forego other activities	Opportunity cost of activities foregone
	Encounters with wild animals	Possibility of attacks from wild animals, threat to safety	–
	Wetlands prone to flooding and waterlogging	Difficulties accessing wetlands	–

hours as they sometimes spent the whole day in the field and sometimes wake up as early as 3 o'clock in the morning. Priority is given to adaptation activities more than other household activities. This shows that adaptation activities disproportionately burden the vulnerable (Barnett and O'Neill 2010) particularly women and children. Reliance on family labor increases vulnerability of women and children. Adaptation in resettlement areas of Chirumanzu is therefore not socially equitable for women and children (Barnett and O'Neill 2010).



## **Worry, Anxiety, and Uncertainty**

Farmers fall behind schedule when they change planting dates to wait for effective rains. Farmers worry and feel anxious as they wait with uncertainty for rains to come. Farmers feel helpless as they wait with uncertainty as to when the effective rains will come. Farmers who irrigate also worry over the risk of drying out of water sources.

## **Pain and Suffering**

Farmers experience pain and suffering due to the poor germination rates and poor crop stand due to insufficient moisture associated with changing planting dates through early and/or dry planting. They are distressed over the inputs, resources, and effort wasted. After early and/or dry planting sometimes very little rains come and they result in seed rot thereby wasting seed, fertilizers, and labor. Farmers also experience pain and suffering as new project ventures fail to start up progressively when they diversify.

## **Effort Spent to Facilitate Smooth Implementation of Adaptation Measures**

The high cost and scarcity of drought tolerant varieties force farmers to spend a lot of time going from one place to the next, sometimes from one town to the next looking for better priced seed. Drought tolerant varieties are no longer readily available on the market in Zimbabwe. Since 2009, the traditional suppliers of drought tolerant varieties have been failing to meet demand because they were unable to cope with hyperinflation (Dekker and Kinsey 2011). Since then drought tolerant varieties have been scarce on the formal market only covering less than 50% of the demand (Willems 2014). This facilitated the mushrooming of a parallel market for drought tolerant varieties where they are charged double or more. Incidentally, this forces farmers to make effort looking for better prices drought tolerant varieties they can afford.

## **Indecision During Allocation of Scarce Resources**

Farmers experience difficulties in allocating scarce resources as they diversify into new project ventures. Potential conflicts in labor allocation and capital investment sharing are common to farmers who diversify. Indecision is therefore common while allocating resources as all the projects will be important to them.

---

## **Ridicule and Embarrassment Associated with Borrowing Equipment**

The lack of mechanical equipment forces farmers to borrow. When they borrow the implements, they are subjected to ridicule and experience feelings of embarrassment. This shows that support networks for adaptation practices sparsely exist among maize farmers in Chirumanzu. Instead of offering social support to other farmers while implementing adaptation practices (Townsend et al. 2015), fellow community members ridicule them. Cooperation and solidarity which are important mechanisms determining the extent to which adaptation measures are adopted are nonexistent among maize farmers in resettlement areas.

The above narrative can be drawn back to the way in which the resettlement program was structured. In particular, the A1 model, communities were created overnight and by chance since most of the times farms were allocated by picking out a number from a hat (Chiweshe 2014). This led to the establishment of “stranger neighboring households” (Barr 2004: 1753) who did not know one another and were therefore forced by to settle and interact. As such, different groups of people with competing views, opinions, and interest would create a conducive environment for noncooperation (Chiweshe 2014).

---

## **Indirect Costs of Adaptation to Climate Variability**

Indirect costs are secondary unintended effects of adaptation activities. Although measurable, they are not valued directly on the market. They are unintentional and often unplanned effects of adaptation with a time lag. Tables 1 and 2 summarize adaptation measures adopted by maize farmers, associated problems and dangers, as well as the related indirect costs.

## **Family Labor Opportunity Cost**

The use of family labor to implement adaptation measures raises the issue of family labor opportunity costs. Although family labor opportunity cost has been identified in existing literature, the indirect aspects surrounding it are not well articulated. In existing literature, labor is considered a variable cost that is direct and tangible as is measurable in man-days per hectare. However, despite the existence of several family labor opportunity cost valuation measures, a common unit of measurements that specifies the cost of important activities foregone while providing labor for adaptation plans is nonexistent.

Maize farmers in resettlement areas rely mostly on family labor. In most cases, farm owners, household members including women and children are forced to forego other important activities while providing labor for adaptation plans. All members of the household provide the required labor for adaptation activities. Commonly, the labor hours provided by household members go unnoticed and mostly unpaid. Hence, the net value of time spent in the next best activity would

have been foregone. Major effects are on children who are excessively burdened as they are obliged to help before they go to school and after school. As such, adaptation disproportionately burdens the most vulnerable (Eriksen and O'Brien 2007) groups of children in resettlement areas which constitute unsustainable adaptation.

Existing literature on family labor does not go further to establish potential conflicts in labor allocation between adaptation through measures such as planting basins and other household duties. Yet, Rusinamhonzi (2015) indicated that there are indeed potential conflicts in labor allocation between adaptation through planting basins and other activities. This tally with findings of this study where adaptation practices were often drawn back by labor bottlenecks. This study illustrate that the use of planting basins disproportionately burdened maize farmers and their families while reducing the incentive to adapt (Barnett and O'Neill 2010). This explains why very few farmers in Chirumanzu adopted it. Potential conflicts in labor allocation among adaptation plans and competing household duties are a form of adaptation cost that is unnoticed.

### **Additional and Unplanned Cost of Production**

Maize farmers are confronted with additional often unplanned costs while implementing adaptation plans. Adaptation measures that require special equipment result in maize farmers incurring unplanned hiring costs. Farmers are constrained by the lack of necessary implements such as hoes, ploughs, and tractors to execute adaptation plans. Farmers resort to hiring implements at a cost paid either paid in cash or in kind. This increase the cost of production and most farmers cannot afford it. Wetland farming calls for extra production costs since farmers need to buy fence to create a barrier that obstructs stray animals from entering the field and eat the maize while they are not watching. This relates to the contention of Adger et al. (2009) and Morrison and Pickering (2012) that inadequate technology presents additional unplanned costs for farmers while executing adaptation plans. Payments made in kind are not given much thought; hence, the cost associated usually goes undetected. Early and/or dry planting often results in replanting twice or thrice when seed fail to germinate due to climate variability extremes such as little rains. This generates additional seed, fertilizer, and chemical requirements per hectare thus raising total input cost. These costs are usually misconstrued as normal variable costs without considering the indirect, additional, and unplanned costs associated.

### **Yield Losses Related to Risk, Unavoidable Delays, and Timing**

Some adaptation measures increased the likelihood of loses rather than gains (Pittelkow et al. 2014). For example, late planting results in grain yield loses of up to 5% for each week of delayed planting (Nyagumbo 2008). In Zimbabwe, Nyakudya and Stoosnijder (2015) mentioned incidences of pests and diseases as

the other reasons why late planting often give lower yields. Similarly, this study established that farmers who diversified with small grains ended up failing to get a market for this alternative crop. Nonetheless, since literature on adaptation largely focuses on benefits brought forth by adaptation and neglects the costs, these processes are rarely deliberated in adaptation cost assessments.

### **Huge Investment Cost for Some Adaptation Practices**

Diversification demands huge investment costs to start new enterprises. Equally, irrigation requires high start-up costs to secure the water source pump and other irrigation facilities for an efficient system. Maize farmers are resource constrained as such these costs are enormous for them.

---

### **Conclusion**

Investing in measures that reduce the impact of climatic variation in maize farming is indeed the missing link for A1 farmers in resettlement areas of Chirumanzu. Measures such as conservation farming, use of drought tolerant varieties, changing planting dates, practicing good crop establishment, wetland farming, and diversification may strengthen maize farmers to fulfill their massive role of safeguarding food and nutrition security. The Government of Zimbabwe intends to make adaptation a national priority. On the international front, adaptation has been identified as the only solution for furthering the Climate Change Policy. This has seen an extensive adoption of various adaptation measures around the globe particularly among smallholder farmers including A1 farmers in Zimbabwe. Several success stories on adaptation have been widely documented. Despite considerable variations in effectiveness of adaptation measures in maize farming, yields have been reportedly improved. Overall, adaptation reduces vulnerability and improves resilience while at the same time reducing incidences of rural poverty. However, overall adaptive capacity and resilience among smallholder farmers especially in the African region including Zimbabwe is reportedly still low. This is partly due to the problems and dangers that accompany the process of adaptation. As such, caution must be taken especially in communities that are making efforts to adapt so that the problems and dangers are managed accordingly. The problems and dangers originate from planning, executing, monitoring, and maintenance of adaptation systems. The problems and dangers are associated with some intangible costs that are difficult to measure in quantitative terms and therefore challenging to assign a monetary value which makes them repeatedly ignored in adaptation cost assessments. The problems and dangers are also associated with indirect costs that are secondary effects of adaptation and cannot be easily comprehended at face value as they are not directly measured in monetary terms. This chapter brings to light the fact that in some cases, adaptation results in problems and dangers that limit adaptive capacity and increase vulnerability to some extent. This chapter contributes to existing literature and

argues that adaptation does not only bring positive outcomes. The chapter progresses the argument that intangible and indirect costs are an enormous part in adaptation planning and cost assessments. This chapter advocates for prioritization of the intangible and indirect costs associated with the problems, dangers, and unintended adaptation effects of adaptation to increase uptake and enhance sustainability. Stakeholders in the climate adaptation arena should not overlook intangible and indirect costs associated to the problems, dangers, and unintended effects that come with adaptation activities in order to enhance social and environmental justice. It is time to practice what is being preached in the climate adaptation arena and not neglect crucial prerequisites of adaptation such as the “first do no harm principle.”

---

## References

- Adam B, Wiredu AN (2015) Cost benefit analysis of climate change adaptation measures on soil and water conservation in Northern Ghana (eds: Ministry of Food and Agriculture GUOH, Institute of Farm Management (Germany)). Csr-Savanna Agricultural Research Institute, Ghana. Online, Ministry of Food and Agriculture, Republic of Ghana
- Adger WN, Dessai S, Goulden M, Hulme M, Lorenzoni I, Nelson DR, Naess LO, Wolf J, Wreford A (2009) Are there social limits to adaptation to climate change? *Clim Chang* 93:335–354
- Adger W, Tara Q, Lorenzoni I, Murphy C, Sweeney J (2013) Changing social contracts in climate-change adaptation. *Nat Clim Chang* 3:330–333
- Agrawala S, Crick F, Jette-Nantel S, Tepes A (2008) Empirical estimates of adaptation costs and benefits: a critical assessment. In: Agrawala S, Fankhauser S (eds) *Economic aspects of adaptation to climate change: costs, benefits and policy instruments*. OECD, Paris
- Agrawala S, Bosello F, Carraro C, de Cian E, Lanzi E (2011) Adapting to climate change: costs, benefits and modelling approaches. *Int Rev Environ Resour Econ* 2011(5):245–284
- Amare ZY, Ayoade JO, Adelekan IO, Zeleke MT (2018) Barriers to and determinants of the choice of crop management strategies to combat climate change in Dejen District, Nile Basin of Ethiopia. *Agric Food Secur* 7(37)
- Andersson J, Giller K, Mafongoya P, Mapfumo P (2011) Diga udye or diga ufe? (Dig-and-eat or dig-and-die?) Is conservation farming contributing to agricultural involution in Zimbabwe? Proceedings of the Regional Conservation Agriculture Symposium, 8–10 February 2011, Emperor’s Palace Hotel and Conference Centre, Johannesburg
- Arfunuzzaman MD, Mamnun N, Islam S, Dilshad T, Syed A (2016) Evaluation of adaptation practices in the agricultural sector of Bangladesh: an ecosystem based assessment. *Climate* 4:11
- Barnett J, O’Neill S (2010) Maladaptation. *Glob Environ Change Hum Policy Dimens* 20:211–213
- Barr A (2004) Forging effective new communities: the evolution of civil society in Zimbabwean resettlement villages. *World Dev* 32(10):1753–1766
- Basset TJ, Fogeliman C (2013) Deja vu or something new? The adaptation concept in climate change literature. *Geoforum* 48(2013):42–53
- Biagini B, Bierbaum R, Stults M, Dobardzic S, McNeely SM (2014) A typology of adaptation actions: a global look at climate adaptation actions financed through the Global Environmental Facility. *Glob Environ Chang* 25(2014):97–108
- Cairns JE, Crossa J, Zaidi PH, Grudloyma P, Sanchez C, Arous JL, Thaitad S, Makumbi D, Magorokosho C, Bänziger M, Menkir A (2013) Identification of drought, heat, and combined drought and heat tolerant donors in maize. *Crop Sci* 53(4):1335–1346
- Chambwera MA, Heal G, Dubeux C, Hallegatte S, Leclerc L, Markandya A, Neumann J (2014) Economics of adaptation. In: *Climate change 2014: impacts, adaptation, and vulnerability*. Part A: Global and sectoral aspects. Contribution of Working Group II to the Fifth Assessment

- Report of the Intergovernmental Panel on Climate Change. Cambridge University Press, Cambridge, UK/New York
- Chinamatira L, Mtetwa S, Nyamadzawo G (2016) Causes of wildland fires, associated socio-economic impacts and challenges with policing, in Chakari resettlement area, Kadoma, Zimbabwe. *Fire Sci Rev* 5(1):1
- Chiweshe MK (2014) Understanding social and solidarity economy in emergent communities: lessons from post-fast track land reform farms in Mazowe, Zimbabwe. UNRISD Occasional Paper: Potential and Limits of Social and Solidarity Economy, No 1. United Nations Research Institute for Social Development (UNRISD), Geneva
- Costinot A, Donaldson D, Smith C (2016) Evolving comparative advantage and the impact of climate change in agricultural markets: evidence from 1.7 million fields around the world. *J Polit Econ* 124(1):205–248
- Dankelman I (2010) *Gender and climate change: an introduction*. Routledge, United Kingdom
- Dekker M, Kinsey B (2011) Coping with Zimbabwe's economic crisis: small-scale farmers and livelihoods under stress. African Studies Centre, Working Paper 93/2011, Leiden
- Doczi J, Ross I (2014) The economics of climate change adaptation in Africa's water sector. A review and way forward. Overseas Development Institute Report Working paper. Overseas Development Institute, London
- Eriksen SH, O'Brien K (2007) Vulnerability, poverty and the need for sustainable adaptation measures. *Clim Pol* 7(2007):337–352
- Fankhauser S (1998) The cost of adapting to climate change. Working paper no 16. Global Environmental Facility, Washington, DC
- Fankhauser S (2009) The costs of adaptation to climate change. Centre for Climate Change Economics and Policy. Paper no 8/Working paper no 7. Grantham Research Institute on Climate Change and the Environment, London
- Forsyth T (2014) Climate justice is not just ice. *Geoforum* 54:230–232
- Friese S (2016) CAQDAS and grounded theory analysis. Max Planck Institute for the Study of Religious and Ethnic Diversity, Göttingen
- Graham S, Barnett J, Fincher R, Mortreux C, Hurlimann A (2015) Towards fair local outcomes in adaptation to sea-level rise. *Climatic Change* 130(3):411–424
- Graham S, Barnett J, Moertreux C, Hurlimann A, Fincher R (2018) Local values and fairness in climate change adaptation: insights from rural Australian communities. *World Dev* 108(2018):332–343
- Gray CL, Mueller V (2012) Natural disasters and population mobility in Bangladesh. *Proc Natl Acad Sci* 109(16):6000–6005
- Gwamuri J, Mvumi B, Maguranyanga EF, Nyagumbo I (2012) Impact of *Jatropha* on rural livelihoods case of Mutoko District, Zimbabwe. RAEIN-Africa Secretariat, Windhoek
- Hallegette S (2009) Strategies to adapt to an uncertain climate change. *Glob Environ Chang* 19(2009):240–247
- Intergovernmental Panel on Climate Change (2014) *Climate change 2014: impacts, adaptation and vulnerability. Part A: Global and sectoral aspects*. In: Contribution of working group II to the Fifth assessment report of the intergovernmental Panel on Climate Change (eds: Field CB, Barros VR). Cambridge University Press, New York
- Kumar K, Shyamsundar P, Nambi AA (2010) The economics of climate change adaptation in India—research and policy challenges ahead. *Policy Note* 6:10–42
- Lunduka RW, Mateva KI, Magorokosho C, Manjeru P (2019) Impact of adoption of drought-tolerant maize varieties on total maize production in south Eastern Zimbabwe. *Clim Dev* 11(1):35–46
- Magnan AK, Schipper ELF, Burkett M, Bharwani S, Burton I, Eriksen S, Gemenne F, Schaar J, Ziervogel G (2016) Addressing the risk of maladaptation to climate change. *Wiley Interdiscip Rev Clim Chang* 7(5):646–665

- Mccarl BA (2007) Adaptation options for agriculture, forestry and fisheries. A Report to the UNFCCC Secretariat Financial and Technical Support Division. <http://agecon2.tamu.edu/people/faculty/mccarl-bruce/papers>
- Menike L, Arachchi K (2016) Adaptation to climate change by smallholder farmers in rural communities: evidence from Sri Lanka. *Proc Food Sci* 6:288–292
- Meyer V, Becker N, Markantonis V, Schwarze R, Van Den Bergh J, Bouwer L, Bubeck P, Ciavola P, Genovese E, Green CH (2013) Assessing the costs of natural hazards-state of the art and knowledge gaps. *Nat Hazards Earth Syst Sci* 13(5):1351–1373
- Mikulewicz M (2017) Politicizing vulnerability and adaptation: on the need to democratize local responses to climate impacts in developing countries. *Clim Dev* 10(1):18–34
- Milman A, Arsano Y (2014) Climate adaptation: contradictions for human security in Gambella, Ethiopia. *Glob Environ Chang* 29(2014):349–359
- Mitchell T, Tanner T, Lussier K (2007) ‘We know what we need’: South Asian women speak out on climate change adaptation, ActionAid and Institute of Development Studies (IDS), University of Sussex
- Mkodzongi G, Lawrence P (2019) The fast-track land reform and agrarian change in Zimbabwe. *Rev Afr Polit Econ* 46(159):1–13
- Morrison C, Pickering C (2012) Limits to climate change adaptation: case study of the Australian Alps. *Geogr Res* 51(1):11–25
- Morse JM (2016) Mixed method design: Principles and procedures (Volume. 4). Routledge
- Mundial B (2006) Investment framework for clean energy and development. J Sports Sci, World Bank, Washington, DC
- Musara JP, Zivenge E, Chagwiza G, Chimvuramahwe J, Dube P (2011) Determinants of smallholder cotton contract farming participation in a recovering economy: empirical results from Patchway district, Zimbabwe. *J Sustain Dev Afr* 13(4):1–3
- Mushunje A, Belete A, Fraser GC (2003) Technical efficiency of resettlement farmers of Zimbabwe. Proceedings of the 41st Annual Conference of the Agricultural Economic Association of South Africa (AEASA), 2–3 October 2003, Pretoria
- Nellemann C, Verma R, Hislop L (2011) Women at the frontline of climate change: gender risks and hopes. A rapid response assessment. United Nations Environment Programme, GRID-Arendal. UNEP, Arendal
- Njaya T, Mazuru N (2014) Emerging new farming practices and their impact on the management of woodlots in A1 resettlement areas of Mashonaland Central Province in Zimbabwe. *Asian Dev Policy Rev* 2(1):1–19
- Nyagumbo I (2008) A review of experiences and developments towards Conservation Agriculture (CA) and related systems in Zimbabwe. In: Goddard T, Zoebisch MA, Gan YT, Ellis W, Watson A, Sombatpanit S (eds) No-till farming systems. World Association of Soil and Water Conservation, Bangkok
- Nyakudya IW, Stoosnijder L (2015) Conservation tillage of rain fed maize in semi-arid Zimbabwe: a review. *Soil Tillage Res* 145(2015):184–197
- Nyamangara J, Mashingaidze N, Masvaya EN, Nyengerai K, Kunzekweguta M, Tirivavi R, Mazvimavi K (2014) Weed growth and labor demand under hand-hoe based reduced tillage in smallholder farmers’ fields in Zimbabwe. *Agric Ecosyst Environ* 187:146–154
- Onwuegbuzie AJ, Leech NL (2007) A call for qualitative power analyses. *Qual Quant* 41(1):105–121
- Paavola J, Adger WN (2006) Fair adaptation to climate change. *Ecol Econ* 56(4):594–609
- Peterson JS (2019) Presenting a qualitative study: a reviewer’s perspective. *Gift Child Q* 63(3):147–158
- Pittelkow CM, Liang X, Linquist BA, van Groenigen KJ, Lee J, Lundy ME, van Gestel N, Six J, Venterea RT, van Kessel C (2014) Productivity limits and potentials of the principles of conservation agriculture. *Nature* 517:365–368

- Rurinda J, Mapfumo P, van Wijk MT, Mtambanengwe F, Rufino MC, Chikowo R, Giller KE (2013) Managing soil fertility to adapt to rainfall variability in smallholder cropping systems in Zimbabwe. *Field Crop Res* 154:211–225
- Rusinamhonzi L (2015) Tinkering the periphery: labour burden not crop productivity increased under no-till planting basins on smallholder farms in Murehwa district, Zimbabwe. *Field Crop Res* 170(2015):66–75
- Sachikonye LM (2003) From ‘growth with equity’ to ‘fast-track’ reform: Zimbabwe’s land question. *Rev Afr Polit Econ* 30(96):227–240
- Schipper ELF (2009) Meeting at the crossroads? Exploring the linkages between climate change and disaster risk reduction. *Clim Change Dev* 1(1):16–30
- Shoko D, Oloo G, Francis J, Kori E (2016) Strategy preference vs adoption: a comparative analysis for Agro-Small and Medium Enterprises’ survival in a challenging economic environment. *The Dyke: Journal of the Midlands State University (Special Issue)*:150–169
- Simba FM, Chayangira J (2017) Rainfall seasons analysis as a guiding tool to smallholder farmers in the face of climate change in Midlands in Zimbabwe. *J Earth Sci Clim Chang* 8(3)
- Smit B, Burton I, Klein RJ, Wandel J (2000) An anatomy of adaptation to climate change and variability. In: *Societal adaptation to climate variability and change*. Springer, Dordrecht
- Smith K, Ward R (1998) *Floods: physical processes and human impacts*. Wiley, New Jersey
- Thebe V (2018) Youth, agriculture and land reform in Zimbabwe: experiences from a communal area and resettlement scheme in semi-arid Matabeleland, Zimbabwe. *Afr Stud* 77(3):336–353
- Thomsen DC, Smith TF, Keys N (2012) Adaptation or manipulation? Unpacking climate change response strategy. *Ecol Soc* 17(3)
- Townsend I, Awosoga O, Kulig J, Fan H (2015) Social cohesion and resilience across communities that have experienced a disaster. *Nat Hazards* 76(2015):913–938
- United Nations Development Programme (2002) *UNDP interim mission report*. Harare
- United Nations Framework Convention on Climate Change (2008) *Investment and financial flows to address climate change: an update*. United Nations Framework Convention on Climate Change Report. United Nations, New York
- Willems F (2014) *Access to inputs in Zimbabwe: changes since the Fast Track Land Reform Programme*. Dissertation submitted in partial fulfilment of Masters in Human Geography, Globalisation, Migration and Development at Radboud University
- World Bank (2010) *Economics of adaptation to climate change: synthesis report*. The World Bank Group, Washington, DC

**Open Access** This chapter is licensed under the terms of the Creative Commons Attribution 4.0 International License (<http://creativecommons.org/licenses/by/4.0/>), which permits use, sharing, adaptation, distribution and reproduction in any medium or format, as long as you give appropriate credit to the original author(s) and the source, provide a link to the Creative Commons license and indicate if changes were made.

The images or other third party material in this chapter are included in the chapter’s Creative Commons license, unless indicated otherwise in a credit line to the material. If material is not included in the chapter’s Creative Commons license and your intended use is not permitted by statutory regulation or exceeds the permitted use, you will need to obtain permission directly from the copyright holder.







# Climate Variability and Rural Livelihood Security: Impacts and Implications

# 23

Kehinde Olayinka Popoola, Anne Jerneck, and Sunday Adesola Ajayi

## Contents

Introduction .....	424
Multistage Selection of Ecological Zones and the Aged .....	426
Ageds' Experience of Climate Variability Impact on Their Livelihood Security .....	427
Conclusion .....	433
References .....	434

## Abstract

In a typical Nigerian village, the majority of the population comprises old people who are mostly economically unproductive due to reduced or loss of physical strength brought about by ageing and ill health. Many of these rural old people still work, and do so outside the formal sector, and are particularly susceptible to the effects of climate variability and change. Few studies have reported on climate change and the rural aged and there is a research gap as regards rural elderly peoples' perception of climate variability impact on them. Since little is known

This chapter was previously published non-open access with exclusive rights reserved by the Publisher. It has been changed retrospectively to open access under a CC BY 4.0 license and the copyright holder is "The Author(s)". For further details, please see the license information at the end of the chapter.

K. O. Popoola (✉)

Department of Urban and Regional Planning, Obafemi Awolowo University, Ile-Ife, Nigeria

A. Jerneck

Lund University Centre for Sustainability Studies, Lund, Sweden

e-mail: [anne.jerneck@LUCSUS.lu.se](mailto:anne.jerneck@LUCSUS.lu.se)

S. A. Ajayi

Department of Crop Production and Protection, Obafemi Awolowo University, Ile-Ife, Nigeria

Institute for Sustainable Development, First Technical University, Ibadan, Nigeria

e-mail: [sajayi@oauife.edu.ng](mailto:sajayi@oauife.edu.ng)

© The Author(s) 2021

W. Leal Filho et al. (eds.), *African Handbook of Climate Change Adaptation*,  
[https://doi.org/10.1007/978-3-030-45106-6\\_200](https://doi.org/10.1007/978-3-030-45106-6_200)

423

about their perception of climate variability impacts and implications on the rural aged especially in relation to their livelihood activities in Sub-Saharan Africa, this chapter therefore examined the impact of climate variability on the livelihood security of the rural aged in different ecological zones of Nigeria.

Both qualitative and quantitative methods were used for data collection. Qualitative data were obtained through interviews with four aged and four aged women selected purposively in each rural community and analyzed using Content Analysis Method. Quantitative data were obtained through structured questionnaire administered to an aged male and an aged female population available in selected houses (the aged are people 60 years and over in age) in selected rural communities in selected ecological zones of Nigeria. Where there was no combination of the two (aged men and aged women), either of the two was also sufficient.

It was discovered that the aged's experiences of climate variability impact relate to the prevailing climate variability characteristic of each ecological zones. The impact on their livelihood in these zones is seen in terms of livestock death, lack of pastures for herds, scarcity of water, pest invasion, delayed planting crop failure, need for irrigation, water logging, drowning of small animals, human and animal illness. This means that planning decisions related to climate change issues should take cognizance of the views of the aged populations especially of those residing in rural areas as they are the most affected by the impact.

---

**Keywords**

Climate variability · Rural aged · Livelihood security · Ecological zones

---

**Introduction**

Climate change implies a shift in the main state of a climate or in its variability, persisting for an extended period that can be decades or longer (Intergovernmental Panel on Climate Change 2007). It has been known for a while to have major global environmental, social, and economic impact (Scholze et al. 2006; Douglas et al. 2008) and poses a major serious threat to sustainable development with adverse effects on the environment, human health, food security, economic activities, natural resource management, and physical infrastructure (Government of Kenya (GOK) 2010). Climate change poses serious risks to society because of the physical characteristics of the planet, the biological resources on which human lives depend, and current social systems that are adapted to existing rather than changing climate conditions (Higgins 2014).

Climate change is rapidly emerging as one of the most serious global problems affecting many sectors in the world especially livelihood. Negative consequences in Africa are already prevalent in terms of frequent floods, droughts, and shift in marginal agricultural systems (Collier et al. 2008). Deschenes and Greenstone

(2012) explained that climate change affects the two most important direct agricultural production inputs, precipitation, and temperature, which in turn affects livelihood. Studies have shown that Africa is getting more vulnerable to climate change/variability impact on livelihood compared to other parts of the World. This is because the livelihoods for 80% of the African population are dependent on rain-fed agriculture which are vulnerable to multiple stresses such as climate change (World Bank 2008). Countries in sub-Saharan Africa may likely suffer most from these consequences because of their greater reliance on climate-sensitive resources like agriculture for sustenance of livelihoods (Eboh 2009).

In Nigeria, about 60% of the populations are rural residents depending on agriculture for their livelihood (Central Bank of Nigeria 2006) and studies have confirmed serious effects of climate change on this population. Their vulnerability to climate change impacts is largely due to the socioeconomic and political context (Thornton et al. 2014). However, all households within a community are not equally vulnerable to climate change impact (Adger 2003). This is because vulnerability is highly differentiated (O'Brien et al. 2007) and varies across: age, gender, income, and type of livelihood. In Nigeria, women, children, and the elderly will be most vulnerable to climate change impact, especially the rural elderly who are economically less productive due to physical weakness brought about by ageing and ill health (Anele 2012).

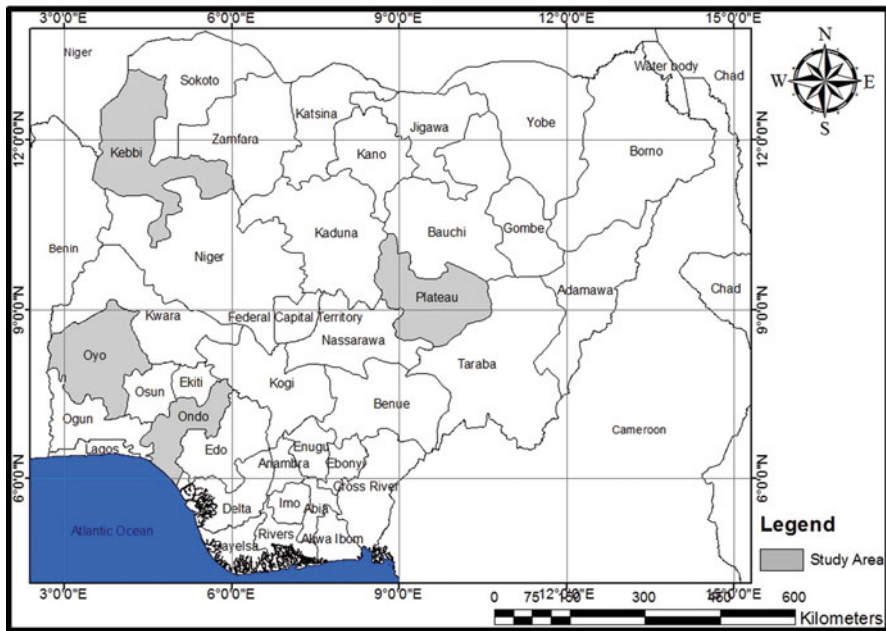
McLeman and Hunter (2010) explained that climate change events, impacts on livelihood and vulnerability differ considerably across geographic and ecological regions. This is because livelihoods are ecologically dependent and some regions and activities are more sensitive to climate change than others (Saarinen et al. 2012). It is therefore relevant to consider ecological characteristics in relation to climate change impacts on livelihood. Also in Sub-Saharan Africa, extreme droughts is already constraining production of food and rearing of livestock (Kebede et al. 2011). For 2050, it is projected that, especially in West Africa, yields could drop by 20–50% due to variability of rainfall reducing length of the growing season (Sarr 2012). There are many studies on climate change/variability and livelihood (Ofoegbu et al. 2017; Ubisi et al. 2017; Aniah et al. 2016; Egbe et al. 2014; Okonkwo et al. 2015; Zeleke and Abera 2014). For instance, Aniah (2016) examined the effects of climate change on livelihoods of smallholder farmers in the Upper East Region of Ghana. The results revealed that droughts, floods, pest and diseases, postharvest losses, declining crop yields, and animal production have threatened smallholder farmers' livelihood activities. Also, Ubisi et al. (2017) investigated the perceived effects of climate change on crop production and household livelihoods of smallholder farmers in Mopani and Vhembe district, South Africa. Their study showed that subsistence farmers perceived prolonged droughts as an impact of climate change leading to low crop yield and high crop failure. These studies focused on the impact of climate change/variability on livelihood activities but the impacts on the livelihood activities of the aged were not considered. Against this backdrop, we have reason to believe that climate change impact on livelihood among the rural aged is likely to vary with geographic location and livelihood activities. Based on Nigeria as a case, this chapter provides answers to this question: How does the

perceived climate variability affect rural livelihood activities of the aged population in selected rural communities of the different ecological zones of Nigeria?

### Multistage Selection of Ecological Zones and the Aged

Nigeria, situated in West Africa on Latitudes 4°0' to 14°0' North and Longitudes 2°2' and 14°30' East, is bounded in the west by the Republic of Benin, in the East by Chad and Cameroon, in the North by Niger Republic, in the South by Gulf of Guinea, and in the North-East by Lake Chad (Map 1). Nigeria is a multiethnic and culturally diverse society divided into 36 autonomous states (World Bank Group 2017). Nigeria has two seasons, the dry and the rainy season, and six ecological zones: Mangrove zone, Forest zone, Montane zone, Guinea savannah zone, Sudan savannah zone, and Sahel savannah zone. This chapter is set in four ecological zones with one state representing each zone—Guinea savannah zone of Oyo State, Mangrove zone of Ondo State (Ondo State), Sudan savannah zone (Kebbi State), and Montane zone (Plateau State) (see Map 1).

In the initial stage, the ecological zones (They are: Mangrove zone, Rain forest, Montane region, Guinea savannah, Sudan savannah and Sahel Savannah) were identified based on Key (1949), Kueppers (1998) classification. Four Ecological Zones were randomly selected out of the six zones. They are: Guinea savannah zone,



**Map 1** Map of Nigeria showing the selected states. (Source: Adopted from Popoola and Ajayi 2019)

Mangrove zone, Montane zone, and the Sudan savannah zone. One State was then selected from each of the selected ecological zones. The states are Oyo State in the Guinea savannah zone (Guinea savannah zone of Oyo State), Ondo State in Mangrove zone (Mangrove zone of Ondo State), Plateau State in Montane zone, and Kebbi State in the Sudan savannah zone. In the next stage, two local government areas were selected from each of the States based on their rurality and climate change impact. The local government areas are: Ilaje and Eseodo in Ondo State; Oorelope and Atisbo in Oyo State; Riyom and Kanke in Plateau State; Jega and Yauri in Kebbi State. In the third stage, three rural settlements were selected from each of the local government areas through a simple random selection process. They are: (Ilepete, Obenla, Ebijimi) in Ilaje LGA; (Igbalekagbo, Uropati, Olorunpupa) in Ese-odo LGA; (Alaguntan, ologundudu, Sooro) in Oorelope LGA; (Alakuko, Sabe, Yowere) in Atisbo LGA; (Ambob, Tahoss, Kwakwi) in Riyom LGA; (Tse, Jinglay, Lebwit) in Kanke LGA; (Akalawa, Duduke, Gindi) in Jega LGA; (Unguwar Kurya, Zara Bimi, Giwa Tazo) in Yauri LGA. To ensure a fair draw for all settlements each settlement in the respective local government area was assigned a number written on a piece of paper, placed in a container, and then drawn from the container without replacement. In the fourth stage, snowball approach was used to identify the houses where the rural aged resides. The aged were defined as people who are at least 60 years of Age.

Both qualitative and quantitative data were used (Primary Data Source). The quantitative data were obtained through structured questionnaire administered to an aged male and an aged female available in the selected houses in the selected rural communities of the selected ecological zones. Where there were no combinations of the two (aged men and aged women), either of the two was also sufficient. The qualitative data includes observations, key informant interviews, and open as well as semi-structured interviews with four aged men and four aged women selected purposively in each of the selected villages. The interviewer used progressive focusing to ask the participants both new and follow up questions. Detailed field notes and audio recording were made throughout the field observations. Data collected was disaggregated by gender to recognize the different experiences of male and female and analyzed using various methods such as descriptive statistics (frequencies and percentages) and SPSS. In the qualitative analysis, Content Analysis Method was used to identify commonalities in terms of recurring aspects and themes as well as differences and contradictions in terms of deviating views and outliers.

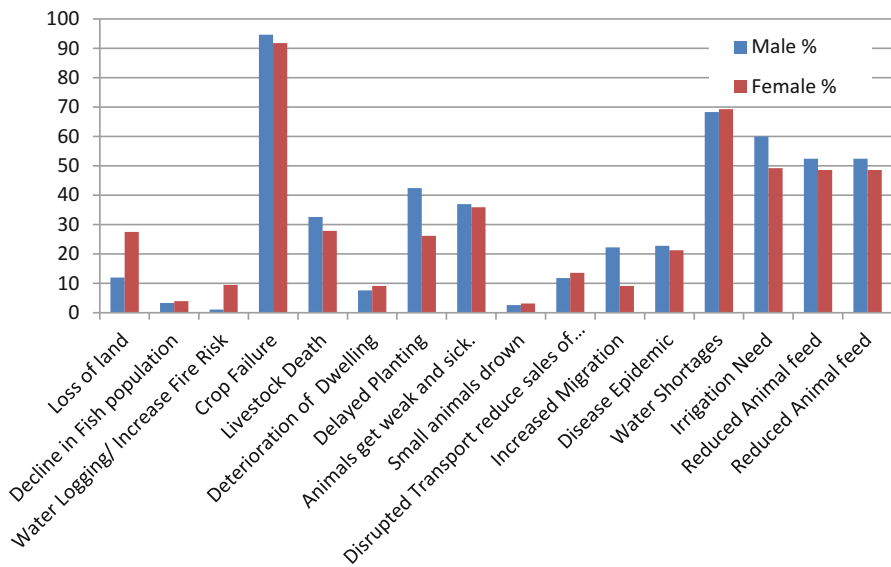
---

## **Ageds' Experience of Climate Variability Impact on Their Livelihood Security**

In this section findings of climate variability impact on livelihood security of the rural aged in selected ecological zones of Nigeria was presented. In focus, the following domains: agriculture and food security; environment; energy; and water resources; as well as human and animal health; dwellings, transport, and migration were placed. According to Ashwill et al. (2011), climate change impact refers to the

social and environmental consequences in terms of water scarcity, loss in agricultural yields, and drops in livestock production, to mention a few. It is important to examine the climate variability impact on livelihood security of the people because it helps informing and tailoring directions for adaptation (Mendelsohn 2008). It is also important to examine the impact on livelihood by gender and geographical locations. Examining the impact by gender helps to understand that the different roles, resources, opportunities, and agency of men and women influence how they experience, perceive, and respond locally to climate change (Ashwill et al. 2011). Vulnerability to climate change impact is highly correlated with its geographical peculiarities (Callo-Concha et al. 2013). Therefore, examining the impact by geographical location helps to determine both the perceived need to adapt and the acceptability of particular adaptive measures because of factors such as: attachment to place, cultural values, social identity, and regional risk attitudes (Adger et al. 2009).

Figure 1 shows the climate variability impact on livelihood security of the rural aged in selected ecological zones of Nigeria. Findings revealed that climate variability has affected the livelihood of the aged to a great extent. For instance, from the table, in Guinea Savannah Zone, 68.3% of the men and 69% of the women complained of water shortage and 60% men and 49.2% women felt the need for irrigation. Also, 42.4% men and 26.2% had to delay their planting; 94.6% of the men and 91.8% of the women lamented about crop failure; 37% of the men and 35.9% of the women worried about their animals getting weak and sick while 32.6% men and 27.9% women had their livestock dead. All these can be attributed to climate



**Fig. 1** Climate variability impact of livelihood security of aged men and women in Guinea Savannah Region of Nigeria. (Source: Author’s Fieldwork)

variability impact. Below, selected comments from aged men and women sharing their experience of climate variability impact on their livelihood security in the different selected villages of Oorelope and Atisbo Local Government Areas of Oyo State, Guninea Savannah Region of Nigeria were included.

Before the change in weather, we planted maize twice a year. But now, we plant it only once. If we try to plant the second time, which is usually done in the eight month, the produce will be very small and not profitable. Just like the one I am holding now (respondent holding a sample maize), who will buy this from us? (**Waliu Hamuzat, Male, 64 years**)

Our yam produce is not as big as before again. The presence of yam leaf is a positive sign of a possible bountiful harvest. During the 10th and 11th month of plantation, some cultivated yams will still have their leaves intact, like before, but now, in the 9th month, some yams would have lost their leaves. Infact, the period when tubers had begun to grow proper, that is when we usually experience the lack of rain (drought). And it is usually when the yam needs the rain the most. Most importantly, these are the periods we usually have constant rainfall before. Now the story is different.

Take for example, if I planted about 3000 yam and I was only able to harvest 100. This can only be related to the heat generated from the dry land and I cannot be at peace with such result (**Kazeem Lawal, Male, 65 years**)

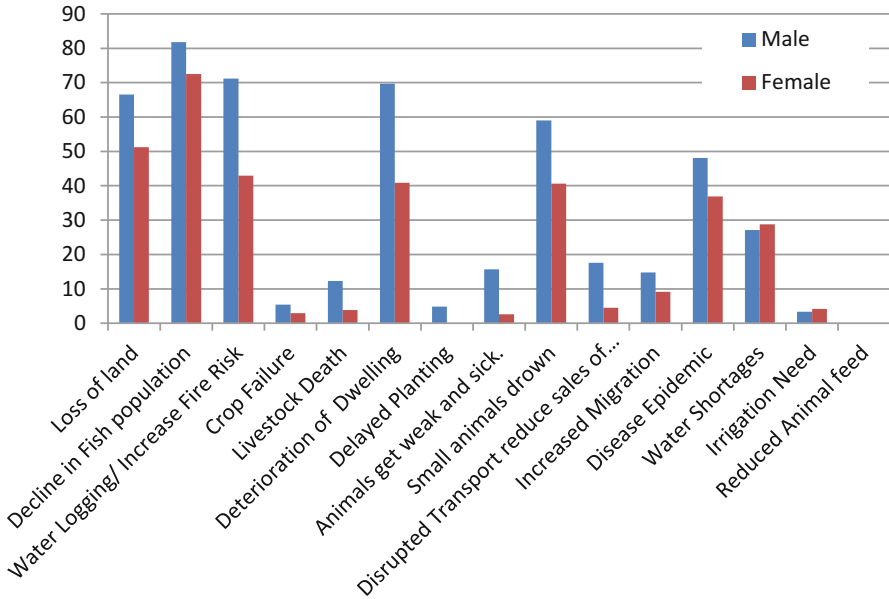
There is shortage of food and water, and our cows are going seriously hungry. This has led to a clash between farmers and the Fulani herdsmen because the cows now go to feed on people's farmland. Any cow caught on a farmland, automatically belongs to the farmland owner. In addition, a lot of cows cannot even stand up on their own again due to hunger. The herdsmen at times usually help them up (**Yussuf Dammani, Male, 62 years**)

Fever most especially, and several other ailment usually surface at this period. Since food is what our body needs most, a shortage of it will lead to sickness in the body (**Durodola Lamina, Female, 73 years**)

The little rain we had was more of heavy storm than water. The storm was too much; in fact the structure we erected as mosque was totally destroyed by the storm. It also destroyed a lot of buildings. The storm is a new experience in this area (**Ajao Abebi, Female, 68 years**)

Figure 2 also shows the climate variability impact on livelihood security of the aged men and women in the Coastal Zone of Nigeria. The table indicated that 81.8% of the men and 72.5% of the women complained about decline in fish species and populations. This is because in a small-scale fishing community, many households are involved in fishery-related livelihood activities such as fishing, postharvest fish processing, fish trading, making and mending of fishing materials (OECD 2001). Therefore, decline in fish species and populations will affect their means of livelihood. Also 79.2% of the aged men and 42.9% of aged women in the area complained about water logging and 59% men and 40.6% women had their small animals drown in the water. Moreover, 69.7% men and 40.9% lamented and worried about the deterioration of their dwellings because of heavy rainfall and flood. In most rural coastal communities of Nigeria, many dwellings are built on piles and raft foundations. These houses easily deteriorate during harsh weather conditions and thus affect the habitability of the aged in the region.

However, in some instances climate variability has some positive impacts on livelihood of rural coastal communities. For instance, one of the positive effects of flooding in the rural coastal communities is the increase in fish catch, especially



**Fig. 2** Climate variability impact of livelihood security of aged men and women in Coastal Zone of Nigeria. (Source: Author’s Fieldwork)

during ocean flooding (Fabiya and Oloukoi 2013). The study revealed that the Atlantic brings large fish to the continental shelf and some large fish are even found in the creeks during extensive flooding. Therefore, climate variability impact is not necessarily negative but can also be positive. Below, are some of the views on the impact of climate variability on their livelihood shared by aged men and women in Ilaje and Eseodo LGAs of Ondo:

Floodwater does not damage our land and properties in the past, it comes for some few hours and subsides back into the ocean but within the past few years it has been staying longer than a month, destroying lives and properties (**Olayemi Elijah**)

Floods are usually associated with heavy rainfall and ocean tides causing damages to our properties and drowning a number of people and animals. During Heavy rainfall, between June and July houses and land becomes waterlogged. The soil becomes saturated with water making it difficult for us to move from one place to another, disturbs our daily activities and causes retrogression in our socio-economic activities. (**Thomas Ogunmola, Male, 67 years**)

Flood has destroyed our crops, fishes and animals. Many of our animals die because of high salt level in the water. The flood water after mixing with sea water becomes polluted causing purging in human. The crude oil clogs the mat making plant (ifere), degrades the bamboo plantation (Opee), and also kills the aquatic animal, which serves as the major source of income to us (**Osamoluwa Male, 71 years**)

Socio-economic activities comes to a standstill during the flooding period, we women will not be able go to the market to trade. There is also high mortality rate in infants and the pregnant women during child labor because we lack health facilities. The only health centre



available is too far from the community and there is no means of transportation most especially during the time of flooding (**Adeola Ebijimi Female 75 years**)

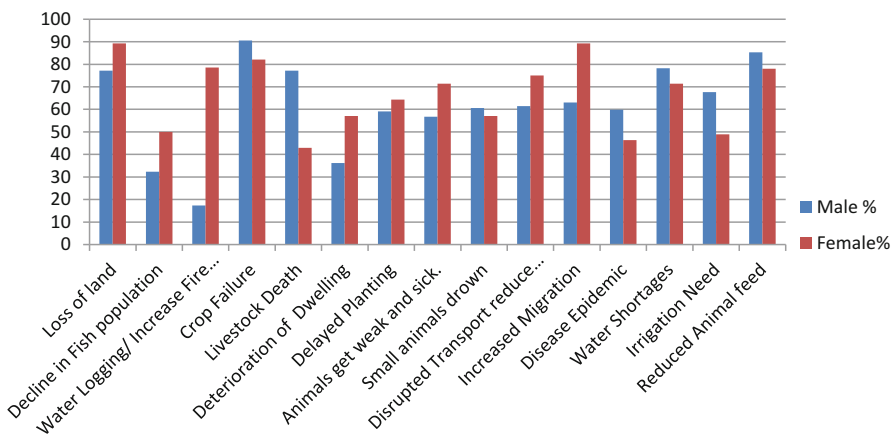
In this year, from January to April, the rainfall was so scanty, resulting into heat wave, the weather became unbearable hot and the soil became too dry and too hot to grow crops on, any crop planted at this period dies off, but from May to July the rainfall became so intense which eventually resulted into flooding (**Ebipatei Jonathan**)

We do encounter a lot of health and environmental hazard, these includes: rheumatism, purging, death of animals, degraded water and soil, erosion, drowning of our children and loss of life in general. (**Obele**)

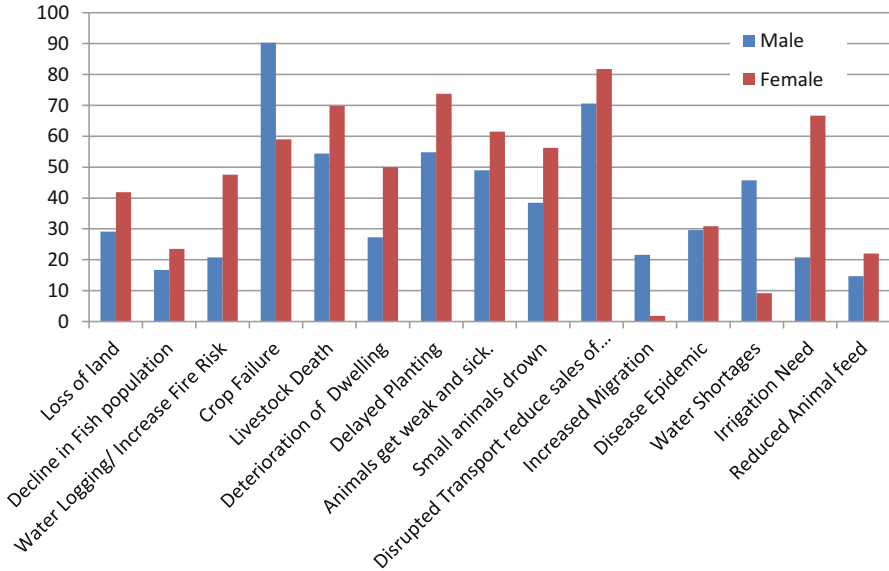
Many of us aged suffer from rheumatism due to extreme cold weather while some of us have lost their lives due to drowning during flooding or tidal surge (**Eyinmiieka Ayebogbon**)

Figure 3 also indicated the impact of climate variability on livelihood security of the rural aged men and women in the Sudan Savannah Zone of Nigeria. The table revealed that 77.2% of the men and 89.3% of the women complained about loss of land. 85.3% of the men and 78.0% of the women complained of reduced pasture for their animals. 78.3% of the men and 71.4% of the women are worried because of water shortage and 67.7% men and 48.9% women felt the need for irrigation. Also, 90.6% of the men and 82.1% of the women lamented about crop failure and 77.2% men and 42.9% lamented about their dying livestock. From all these analysis, it is obvious that livelihood in Sudan Savannah Zone are affected by climate variability impact of drought and irregular rainfall. This is in line with Challinor et al. (2007) who explained that agricultural potential of the Sudan Savanna in West Africa is limited by insufficient water availability due to high rainfall variability and frequent droughts.

Our major occupation here is faming and rearing of livestock animals. Everything is okay. The only change is the issue of rain and drought. Before, rain starts around April and



**Fig. 3** Climate variability impact of livelihood security of aged men and women in Sudan Savannah Region of Nigeria. (Source: Author’s Fieldwork)



**Fig. 4** Climate variability impact of livelihood security of aged men and women in Montane Region of Nigeria. (Source: Author’s Fieldwork)

sometimes March. But now, that the climate has changed, it may start around June or July (**Al Haruna**)

We have a river here. Sometimes this river overflows and leads to flood. There is nothing we can do about such a situation because we do not have a choice. (**Aisha Muhammad**)

If you observe the route we followed here, the erosion has affected the bridge there. We have got about 30 bags of cement to do the bridge again. Even as we speak, if rain should fall, no one will be able to leave this town until the water level reduces (**Kulu Galadima**)

The drought usually affects our cultivated crops, in most cases we do re-planting after the drought might have destroyed the cultivation. So we plant immediately after the first rainfall that comes after a drought. For the flood, there is nothing we can do about it. What we do in most cases is to gather the redeemable crops and plant again after flood. (**Amina Hakimi**)

Figure 4 reveals the impact of climate variability on livelihood security of the rural aged men and women in the Montane Zone of Nigeria. The table revealed that 70.6% of men and 81.8% of women were not happy about disrupted transport reducing sales of goods; 58% of the men and 59% of the women complained of crop failure; 54.8% men and 73.8% talked about delayed planting; 49% of men and 61.5% of the women worried about their animals getting weak and sick while 54.4% men and 69.8% women complained about their dead livestock. This analysis was further corroborated with comments on the experiences of the aged men and women’s climate variability impact on their livelihood security in the different selected villages of Plateau State of Montane Zone of Nigeria.

In this area we do not experience flood, but over there (neighboring village), all their houses and roads are filled with flood (**Sunday Gaarus**)

Lot of houses are usually affected. But for crops, only rice will do well in such condition. Last year we harvested plenty rice because rice needs a lot of water to grow. But crops like corn, guinea corn did not survive the weather. Millet also, for those farmers that had enough rain harvested it as well. We got millet here last year because we cultivated it around July ending to October ending, because it also can survive heavy rain. But crops like the ones I mentioned earlier, corn, and guinea corn will not survive it (**Zababiya**)

In other places, they have not even had any rainfall at all this year. But we here are very lucky to have experienced several rainfall, though heavy. If we now start complaining about heavy rain, what should other places that have not experienced rain say? We do not know why God has decided to do it this way. So, to tell you I have an idea is unexplainable. Everything is God's doing (**Mrs Ngyuk**)

Generally, the impact and the experience of climate change on livelihood security of the aged men and women is peculiar to each ecological zone. This is because each ecological zone has its own peculiar characteristics. This is in line with Callo-Concha et al. (2013) that says vulnerability to climate change impact is highly correlated with its geographical peculiarities. Therefore, the impact on the respondents is relative to the geographical characteristics.

---

## Conclusion

Climate change is rapidly emerging as one of the most serious global problems affecting many sectors in the world especially rural livelihoods in agriculture, cattle rearing, crop farming, fishing, hunting, mining, tourism, and craft and weaving. It was found that the rural aged populations in Nigeria are highly vulnerable to climate change impact, especially in their livelihood security which was discovered to differ by region and by activity. This is in line with Garai (2014) which assessed climate change impact on the livelihoods of coastal people in the south-western part of Bangladesh revealed the elderly as part of the most at risk and vulnerable to climate change impact because of their inability to adapt to unfavorable environmental condition.

While some areas are generally more sensitive to climate change (Saarinen et al. 2012), some livelihoods and activities are more ecologically dependent and exposed to climate change impact. In consequence, the rural aged experience climate variability impact on their livelihood differently in different ecological zones, and their experience is based on the prevailing climate variability characteristics in each ecological zone.

In the Guinea and Sudan savannah zones, the prevailing climatic variability characteristics are drought, desertification, excessive heat and increased temperature, decline in rainfall, delayed onset of rainfall to mention a few. This is also in line with Ayanlade and Ojebisi (2019) which assessed herders' responses to climate variability and changes in the Guinea Savannah region of Nigeria. The study confirmed climate variability characteristics like excessive heat, reduced and delay onset of rainfall, prolonged dry spell, drought to mention a few in the area. Also in the Coastal zone the prevailing climatic variability characteristics are flooding, earlier onset of rain, erosion, increased frequency in storms. The impact on their livelihood in these zones is mainly associated with livestock death, lack of pastures for herds,

scarcity of water, pest invasion, delayed planting crop failure, need for irrigation, water logging, drowning of small animals, human and animal illness. This implies that government planning and decision making related to climate change should take the views of the aged populations into consideration, especially for those rural areas affected most by climate change impact.

**Acknowledgments** This research was supported by funding from Department for International Development (DfID), in the UK, under the program Climate Impacts Research Capacity and Leadership Enhancement (CIRCLE), implemented by the African Academy of Sciences and the Association of Commonwealth Universities.

---

## References

- Adger WN (2003) Social capital, collective action, and adaptation to climate change. *Econ Geogr* 79(4):387–404
- Adger WN, Dessai S, Goulden M et al (2009) Are there social limits to adaptation to climate change? *Clim Chang* 93(3–4):335–354
- Anele D (2012) A brief note on the condition of rural areas in 0020Nigeria on January 29, 2012. The Vanguard Newspaper. <https://www.vanguardngr.com/2012/01/a-brief-note-on-the-condition-of-rural-areas-in-nigeria/>
- Aniah P, Kaunza-Nu-Dem MK, Abindaw BA, Millar D (2016) Characterizing and explaining smallholder households views and understanding of climate change in the Bongo District of Ghana. *Earth Sci* 5(2):26–38
- Ashwill M, Flora C, Flora J (2011) Building community resilience to climate change: testing the adaptation coalition framework in Latin America. The World Bank, Washington, DC
- Ayanlade A, Ojebisi SM (2019) Climate change impacts on cattle production: analysis of cattle herders' climate variability/change adaptation strategies in Nigeria. *Change Adaptat Socio Ecol Syst* 5(1):12–23
- Callo-Concha D, Gaiser T, Webber H, Tischbein B, Müller M, Ewert F (2013) Farming in the West African Sudan Savanna: insights in the context of climate change. *Afr J Agric Res* 8(38):4693–4705
- Central Bank of Nigeria (2006) Statistical bulletin
- Challinor A, Wheeler T, Garforth C, Crauford P, Kassam A (2007) Assessing the vulnerability of food crop systems in Africa to climate change. *Clim Change* 83:381–399
- Collier P, Conway G, Venables T (2008) Climate change and Africa. *Oxf Rev Econ Policy* 24(2):337–353
- Deschenes O, Greenstone M (2012) The economic impacts of climate change: evidence from agricultural profits and random fluctuations of weather. *Am Econ Rev* 102(7):3761–3773
- Douglas AC, Mills JE, Niang M, Stepchenkova S, Byun S, Ruffinia C et al (2008) Internet addiction: meta-synthesis of qualitative research for the decade 1996–2006. *Comput Hum Behav* 24:3027–3044
- Eboh E (2009) Implications of climate change for economic growth and sustainable development in Nigeria Enugu forum policy paper 10. African Institute for Applied Economics, Enugu
- Egbe C, Yaro MA, Okon AE, Bisong FE (2014) Rural people's perception to climate variability/change in Cross River State Nigeria. *J Sustain Dev* 7(2):25
- Fabiyi O, Oloukoi J (2013) Indigenous knowledge system and local adaptation strategies to flooding in coastal rural communities of Nigeria. *J Indig Soc Dev* 2(1):1–19
- Garai J (2014) The impact of climate change on the livelihoods of coastal people in Bangladesh: a sociological study. In: Leal FW, Alves F, Caeiro S, Azeiteiro UM (eds) *International perspectives on climate change: Latin America and beyond*. Springer, Cham, pp 151–163

- Government of Kenya (GoK) (2010) National climate change response strategy. Government Printer, Nairobi
- Higgins PAT (2014) Climate change as a public and policy issue. *Bull Am Meteor Soc* 95:780–781
- IPCC (2007) Impact, adaptation and vulnerability: contribution on working group 1 of the Intergovernmental Panel on Climate Change to the third Assessment Report of IPCC. Cambridge University Press, London
- Keay RWJ (1949) An example of Sudan zone vegetation in Nigeria. *J Ecol* 37:335–364
- Kebede A, Hasen A, Negatu W (2011) A comparative analysis of vulnerability of pastoralists and agro-pastoralists to climate change: a case study in Yabello Woreda of Oromia Region, Ethiopia. *Ethiop J Dev Res* 33(1):61–95
- Kueppers K (1998) Evaluation of the ligneous strata of the vegetation of the Zamfara reserve. I. In: Prospects of pastoralism in West Africa. Reihe I, vol 25. Tropeninstitut, Giessen, pp 41–47
- McLeman R, Hunter LM (2010) Migration in the context of vulnerability and adaptation to climate change: insights from analogues. *Wiley Interdiscip Rev Clim Chang* 1(3):450–461
- Mendelsohn R (2008) The impact of climate change on agriculture in developing countries. *J Nat Resour Pol Res* 1(1):5–19
- O'Brien KL, Eriksen S, Nygaard LP, Schjolden A (2007) Why different interpretations of vulnerability matter in climate change discourses. *Clim Pol* 7(1):73–88
- OECD (2001) OECD Annual Report
- Ofoegbu C, Chirwa P, Francis J, Babalola F (2017) Assessing vulnerability of rural communities to climate change: a review of implications for forest-based livelihoods in South Africa. *Int J Clim Change Strateg Manag* 9(3):374–386
- Okonkwo C, Demoz B, Sakai R, Ichoku C, Anarado C, Adegoke J, Amadou A, Abdullah SI (2015) Combined effect of El Niño southern oscillation and Atlantic multi decadal oscillation on Lake Chad level variability. *Cogent Geosci* 1:1117829
- Popoola K, Ajayi S (2019) Rural Ageds' awareness and perception of climate variability in Kanke and Riyom local government areas of Plateau State, Nigeria. *Arch Current Res Int* 16(1):1–13. <https://doi.org/10.9734/ACRI/2019/46174>
- Saarinen J, Hambira WL, Athlopheng J, Manwa H (2012) Tourism industry reaction to climate change in Kgalagadi South District, Botswana. *Dev South Afr* 29(2):273–285
- Sarr B (2012) Present and future climate change in the semi-arid region of West Africa: a crucial input for practical adaptation in agriculture. *Atmos Sci Lett* 13(2):108–112
- Scholze M, Knorr W, Arnell NW, Prentice IC (2006) A climate-change risk analysis for world ecosystems. *Proc Natl Acad Sci USA* 103(35):116–120
- Thornton PK, Ericksen PJ, Herrero M, Challinor AJ (2014) Climate variability and vulnerability to climate change: a review. *Glob Chang Biol*
- Ubisi NR, Mafongoya PL, Kolanisi U, Jiri O (2017) Smallholder farmer's perceived effects of climate change on crop production and household livelihoods in rural Limpopo province, South Africa. *Change Adapt Socioecol Syst* 3:27–38
- World Bank (2008) Agriculture for development. World development report. The World Bank, Washington, DC
- World Bank Group (2017) The world bank annual report
- Zelege MT, Abera Y (2014) Determinants of the adoption of land management strategies against climate change in Northwest Ethiopia. *ERJSSH* 1(1):93–118

**Open Access** This chapter is licensed under the terms of the Creative Commons Attribution 4.0 International License (<http://creativecommons.org/licenses/by/4.0/>), which permits use, sharing, adaptation, distribution and reproduction in any medium or format, as long as you give appropriate credit to the original author(s) and the source, provide a link to the Creative Commons license and indicate if changes were made.

The images or other third party material in this chapter are included in the chapter's Creative Commons license, unless indicated otherwise in a credit line to the material. If material is not included in the chapter's Creative Commons license and your intended use is not permitted by statutory regulation or exceeds the permitted use, you will need to obtain permission directly from the copyright holder.



# Climate Change Impact on Soil Moisture Variability: Health Effects of Radon Flux Density Within Ogbomoso, Nigeria

# 24

Olukunle Olaonipekun Oladapo, Leonard Kofitse Amekudzi, Olatunde Micheal Oni, Abraham Adewale Aremu, and Marian Amoakowaah Osei

## Contents

Introduction .....	438
Climate Change and Soil Moisture .....	439
Radon and Human Health .....	440
Simulation and Forecasting of Soil Moisture Within Ogbomoso Using the Swat Model .....	441
The SWAT Model .....	441
Soil Moisture Observation .....	444
Soil Moisture Simulation .....	445
Forecasted Soil Moisture .....	447
Estimation of Radon Flux Density .....	448
Conclusion .....	449
References .....	450

This chapter was previously published non-open access with exclusive rights reserved by the Publisher. It has been changed retrospectively to open access under a CC BY 4.0 license and the copyright holder is “The Author(s)”. For further details, please see the license information at the end of the chapter.

O. O. Oladapo (✉)

Department of Science Laboratory Technology, Ladoké Akintola University of Technology, Ogbomoso, Nigeria  
e-mail: [ooladapo66@lautech.edu.ng](mailto:ooladapo66@lautech.edu.ng)

L. K. Amekudzi · M. A. Osei

Department of Physics, Kwame Nkrumah University of Science and Technology, Kumasi, Ghana

O. M. Oni

Department of Pure and Applied Physics, Ladoké Akintola University of Technology, Ogbomoso, Nigeria  
e-mail: [omoni@lautech.edu.ng](mailto:omoni@lautech.edu.ng)

A. A. Aremu

Department of Physics with Electronics, Dominion University, Ibadan, Oyo, Nigeria

---

**Abstract**

Climate affects the quantity of soil moisture within the surface of the earth and this is obtained by affecting the amount of radon flux density escaping from the land surface. This chapter contains the evaluation of climate change conditions as it affects the variability of soil water for the purpose of estimating the health effects of radon flux density within Ogbomoso metropolis. The simulated soil moisture content around Ogbomoso was done for a period of 34 years using the hydrological model, Soil Water Assessment Tool (SWAT). The calibration and validation of the SWAT model was done using the daily observed soil moisture content. The simulated daily soil moisture within Ogbomoso showed good performance when calibrated and validated. A 20 years prediction of the daily soil moisture content was done using the SWAT model. The estimation of the radon flux density for the study area was obtained using the simulated soil temperature and soil moisture from the SWAT model. In this chapter, the UNSCEAR radon flux formula was used for the radon flux estimate. The result showed that the UNSCEAR radon flux formula performed well in estimating the radon flux density in the study area. The mean value of the radon flux density of  $15.09 \text{ mBqm}^{-2} \text{ s}^{-1}$  falls below the estimated world average of  $33 \text{ mBqm}^{-2} \text{ s}^{-1}$  by UNSCEAR stipulated for land surface. The results showed that Ogbomoso region is not prone to high risk of radon exposure to the public. The estimation of the radon flux density value suggested that there is no radiological health hazard such as lung cancer or any other respiratory tract diseases to the inhabitant of Ogbomoso, Nigeria.

---

**Keywords**

Climate change · Soil moisture · Radon flux density · Estimating · SWAT model · Ogbomoso · Simulating and forecasting

---

**Introduction**

Climate change has been reported to have significant effects on the amount of soil moisture within the land surface (Schery et al. 1989). This is attainable by managing the quantity of radon emanating from the earth. The main hydrology and climate variable that affects the land surface processes is soil moisture (Tanner 1980; Schery et al. 1989). Soil moisture is a major variable for a large number of uses, including numerical weather forecasting, flood prediction, agricultural drought evaluation, water resources management, and health evaluation (Zhang et al. 2008). Despite the principal importance of soil moisture to agricultural performance, crop observation, and yield prediction, soil moisture statistics is not widely obtainable on a territorial scale in Nigeria. Only finite data sets of soil moisture exist in Nigeria because it is a strenuous property to measure. Soil moisture is naturally diverse because of dissimilarity in moisture-holding abilities of the soil at a very small scale



and topography. The soil moisture is mostly measured by agro-meteorological experimental stations which are very insufficient in Nigeria. The data obtained from these stations are too few to investigate how the atmosphere relates with the land surface because they are measured basically for agriculture. Apart from these, agro-meteorological experimental stations are not available in Ogbomoso metropolis. It is paramount to seek a way to simulate this limited variable.

Investigation has shown that variation in soil moisture have evidential effects on changes in radon concentration (Radon-222) in the atmosphere (Brookins 1990). Radon is a natural radioactive inert gas whose inhalation in excess dose may lead to adverse health effect such as lung cancer. Factors such as climatic parameters, diffusivity, and radon concentration have been identified as some of the factors that determined the concentration of radon in the atmosphere (Zahorowski et al. 2004; Fields 2010). Soil moisture is a major parameter that determines the amount of radon exhalation from the earth surface and radon concentration in the atmosphere (Tanner 1980; Ball et al. 1983; Zhou et al. 2005; Sheffield and Wood 2008). The purpose of this chapter is to assess the health effects of radon flux density due to the impact of climate change on soil moisture within Ogbomoso metropolis, Nigeria. This chapter will provide an all-inclusive, evidence-based, measurable estimation of simulated and forecasted soil moisture for assessing radon flux-related health effect in Ogbomoso, Nigeria.

In this chapter, the simulation and forecasting of the soil moisture from the available meteorological data and other relevant data using the Soil Water Assessment Tool (SWAT) model was investigated to estimate the health effects of radon flux density distribution in the atmosphere. This chapter, therefore, seeks to use the relationship between soil moisture and radon emanation from the ground surface to estimate radon flux density distribution in the atmosphere within Ogbomoso. The objective of this chapter is to investigate the effects of change in climate on the variability of soil moisture for the purpose of estimating radon flux density in the Ogbomoso, Nigeria. The specific objectives of this chapter are to obtain a quantitative estimation of (a) the simulated soil moisture, (b) the forecasted soil moisture, (c) the radon flux density above the land surface, and (d) to investigate the health risk of the estimated radon flux density.

---

## Climate Change and Soil Moisture

In the interaction of land and the atmosphere, the amount of water in the top soil plays a very principal role (McColl et al. 2017; Koster et al. 2004). Soil moisture is propelled by climate, more significantly by precipitation and temperature (Feng and Liu 2015). Precipitation is the major source of soil moisture, and changes in precipitation will impact the amount of water in the top soil. Furthermore, changes in temperature also affect soil moisture by managing evapotranspiration (Wang et al. 2018a). The application of soil moisture for weather prediction (Alexander 2011; Wang et al. 2018b), drought observation (AghaKouchak 2014), hydrological modeling (Wanders et al. 2014), and vegetation variation (Chen et al. 2014) are gaining

wide application in recent time. The global warming today and movement of the water cycle may cause changes in soil moisture variability (Sheffield and Wood 2008). It has been reported that changing vegetation can also alter the amount of water in the top soil (Sterling et al. 2013). Vegetation variation has been discovered to affect field ability and soil penetration, thus altering soil moisture (Ouyang et al. 2018). These factors, through some complex relationships, alter soil moisture. Climate variation has been discovered to impact soil moisture greatly. The effects of change in climate and change in vegetation have been reported in literatures.

This chapter considers the implications of change in climate on soil moisture for estimating the health effect of radon flux density. The various soil moisture measuring stations, which are few in number, do not consider the different soil types, soil characteristics, land cover and land use, topography, etc. on the soil moisture. The observation of soil moisture is very scarce. Instead of making use of observation that is limited, numerical models have been employed over time to investigate the changes in hydrological processes and soil moisture, which play a key role in this regard. Numerous hydrological models exist today that can be used for the purpose of simulating the hydrological processes of a watershed. Each model possesses its own pros and cons. The purpose to which an investigation is carried out determines the choice of model to be used. This chapter seeks to examine the Soil Water Assessment Tool (SWAT) model (Arnold et al. 1998) which was chosen due to its ability to simulate hydrologic processes. Another strength of the SWAT model is the fact that it takes into consideration the effects of vegetation properties, topography, soil characteristics, and land type and land cover on the hydrological processes of the soil. This is made possible with the aid of a Digital Elevation Model (DEM) with a very high resolution. Over the years, the SWAT model has become accepted on a global scale as a strong modeling tool suitable for simulating watershed hydrology (Gassman et al. 2007). The SWAT has found application in extensive scope of environmental situations, watershed scales, and framework analysis as described by Gassman et al. (2007). In this chapter, some meteorological data collected from NIMET for Ogbomoso metropolis were fed into the SWAT model to simulate and forecast soil moisture over Ogbomoso. The simulated soil moisture data were used to estimate radon flux density, thereby examining the health effect over Ogbomoso region.

---

## Radon and Human Health

Over the years, radon gas has been studied for two primary purposes. The first purpose is to investigate the extent to which the general public is exposed to it. Secondly, it was studied to detect the various transfer processes in the atmosphere. The breathing in of radon and its momentary progeny account for about half of the effective dose from all natural sources of ionizing radiation. One of the main challenges of radiation protection to the public is the development of lung cancer as a result of inhalation of the progeny of radon (UNSCEAR 1993). Whenever radon is inhaled in high concentration, it usually leads to diverse health implications.

Atmospheric radon, which is an inert gas with a half-life of 3.82 days, has been identified as detectors for atmospheric transport. It also doubles as indicators for evaluating and simulating environmental activities (Brookins 1990; Iida et al. 1996; Wang et al. 2004, Zahorowski et al. 2004; Ohkura et al. 2009). Radon concentration in soil and radon exhalation from the soil surface depend on many physical characteristics. These characteristics are related to soil parameters, such as radium content and the internal structure of the soil. Other physical parameters include type of the mineralization, soil porosity, grain size of the soil, permeability of the soil, and emanation coefficient (Mazur et al. 1999; Aburnurad and Al Tamimi 2001). The release of radon gas from the soil to the atmosphere is associated with some of the same processes that control the soil/air exchange of important greenhouse gases like CH<sub>4</sub>, CO<sub>2</sub>, and NO<sub>2</sub>. Radon does not go through complex chemical reactions and its source term is relatively well known (<sup>226</sup>Ra in soil).

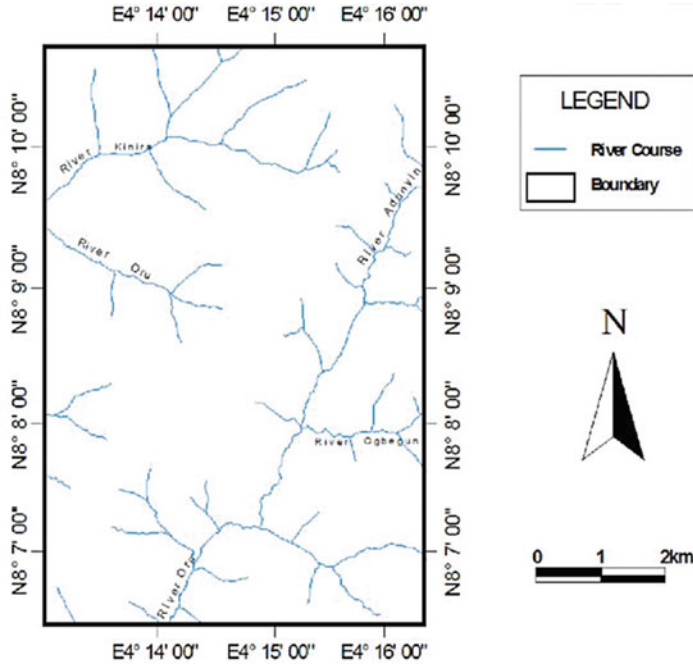
Measurement of radon concentration in the atmosphere has been used for the validation climate models. Due to insufficient radon flux density measurement, measurement of atmospheric radon has been employed in the validation radon flux density from the soil (Kritz et al. 1998; Gupta et al. 2004; Zhang et al. 2008). Therefore, statistics on the territorial distribution of <sup>222</sup>Rn exhalation from the earth's surface is regarded as useful for recognizing areas with a health risk of high radon exposure to public. This chapter therefore aimed to use the simulated and forecasted soil moisture to estimate the health effects of radon flux density of Ogbomoso metropolis. Studies of the radon flux densities are able to provide information on the interaction of exchange of gases between the soil and the atmosphere for the purpose of estimating pure health implications of the inhalation of these gases.

---

## **Simulation and Forecasting of Soil Moisture Within Ogbomoso Using the Swat Model**

### **The SWAT Model**

Soil moisture, which is the amount of water in the upper layer of the soil, has been proven to be affected by changes in climatic properties due to alteration in some meteorological parameters such as precipitation, temperature, relative humidity, solar radiation, and wind speed. The alterations in these parameters are employed in the simulation and forecast of the soil moisture over a particular region provided that relevant data for that region are available. The Soil Water Assessment Tool model known as the SWAT model was used for this purpose within Ogbomoso metropolis. Ogbomoso, which is geographically situated within 4°10'E to 4°20'E longitude and 8°00'N to 8°15'N latitude, is investigated in this chapter. The area is situated within the crystal-like Vault of Nigeria (MacDonald and Davies 2000). In Ogbomoso, rocks are classified as either quartzites or gneisses (Ajibade et al. 1988). The agricultural watershed considered in this research work where the simulation and forecasting of soil moisture was carried out is situated within Ogbomoso North Local Government Area as shown in Fig. 1 (Adabanija et al. 2014). Simulation of



**Fig. 1** The map showing the area within the agricultural watershed (Adabanija et al. 2014)

hydrology within this agricultural watershed was considered under diverse topography, vegetation, climatic condition, and soil. The total drainage of the Ogbomoso watershed accounts for a total of 8.58 km<sup>2</sup>. Ogbomoso, which lies between the savannah and the rain forest, has wet and dry tropical climate. The temperature of the region is fairly uniform throughout the year. It has an average rainfall and temperature of 1200 mm and 26.20 °C annually, respectively. The territorial district of Ogbomoso has four seasons similar to other southern Nigeria. The initial raining season in the region starts from April to July characterized by high humidity and heavy rainfall. It is usually interrupted by a short dry period in August before the rainy season resumes again, this time for a short wet season between September and October. The fourth season is the harmattan season which spans between November and ending in the middle of March. The region experiences a relative humidity between 75% and 95%. Ogbomoso region, being a low land forest, has agricultural activities as major activities of the inhabitants. Figure 1 shows the region of investigation within Ogbomoso metropolis.

“The SWAT has been employed to simulate watersheds globally, it is most frequently chosen due to its vigorous ability to compute the impacts of land management practices on hydrological processes, water quality, and crop growth” (Arnold et al. 1998). In this chapter, the QSWAT, which is a type of the SWAT2012 model, assembled with QGIS 1.4 was employed. The SWAT model operates by breaking a watershed into sub-basins, connected by a stream grid. The Hydrological

**Table 1** Input database and sources for the SWAT model

Data Type	Source
Digital Elevation Model	SRTM 1-Arc-Second Global v3 (30 m)
Land-Use Data	MODIS (15-arc) (Broxton et al. 2014)
Soil Data	Digital global soil map FAOv3.6
Meteorological data	Nigerian Meteorological Agency (1984–2017)
Climate Projection Data	Canadian Regional Climate Model (2018–2037)

**Table 2** Statistical model performance for the calibration and validation procedure (Oladapo et al. 2018)

Procedure	Regression coefficient ( $R^2$ )	Nash and Sutcliffe efficiency ( $E_{NS}$ )	Percentage difference (D)
Calibration	0.91	0.64	13
Validation with ESA CCI	0.81	0.53	11
Validation with in situ measurement	0.88	0.84	8
Standard	>0.6	>0.5	≤15%

Response Unit (HRU) is the place where the simulation was carried out, which is logged in each basin. The simulated variables (water, sediment, nutrients, and other pollutants) are first simulated at the HRU and then passed through the stream to the water outlet (Arnold et al. 1998; Neitsch et al. 2005). The study on soil moisture simulation and forecasting was first investigated within Ogbomoso by Oladapo et al. (2018) with the aid of climatic data inputs such as precipitation, maximum and minimum temperature, solar radiation, relative humidity, and wind speed. Secondary data of daily precipitation, maximum temperature and minimum temperature data, solar radiation, the humidity, and the wind speed were all collected from the Nigerian Meteorological Agency. The data cover between 1979 and 2017. Other data sources including the digital elevation model, land use data, soil data, and climate progression data of the study were used in the simulation and the forecast of the soil moisture in the area (Table 1).

Since Ogbomoso is a natural hydrological setting, five years daily satellite-based soil moisture data (2006–2010) from ESA CCI soil moisture project for the region under investigation were used for the SWAT model calibration. The laid down method of calibration for the SWAT model was carefully followed (Santhi et al. 2001; Neitsch et al. 2005). Due to lack of long-term in situ measurement of soil moisture at the study area, both the short-term in situ measurement of daily soil moisture taken at the study area between April and July 2017 (Oladapo et al. 2018) and five years daily soil moisture data from ESA CCI (2011–2015) were used to validate the SWAT model (Oladapo et al. 2018). Three different model performance statistics were carried out. They are Nash and Sutcliffe efficiency ( $E_{NS}$ ), percentage difference (D), and the regression coefficient ( $R^2$ ). A calibration and validation of  $E_{NS}$ , D, and  $R^2$  for hydrology at  $E_{NS}>0.5$ ,  $D\leq 15\%$ , and  $R^2>0.6$ , respectively, for SWAT model was adopted (Santhi et al. 2001; Moriasi et al. 2007). The three

statistical model performance used in the calibration and validation procedure for the soil moisture are presented in Table 2.

### Soil Moisture Observation

Five-year satellite-based soil moisture observation data from daily soil moisture data of ESA CCI (2011–2015) and observed soil moisture from the study were obtained. Figure 2 shows the trend in the daily observed soil moisture values during the rainy season (April–July 2017). The highest, lowest, and the mean precipitation are 98.35 mm, 1.98 mm, and 48.64 mm, respectively (Oladapo et al. 2018). An increasing precipitation trend was observed from April to July 2017 in the study area. The increasing soil moisture is likely related to the increasing precipitation between April and July which is the rainy season in the study area. This is largely due to reducing temperature during this period. A short variation in daily precipitation was observed in the region as shown in Fig. 3. Model simulated daily soil moisture values from the sub-basin were compared with the daily observed soil moisture values from the sub-basin were compared with the daily observed soil

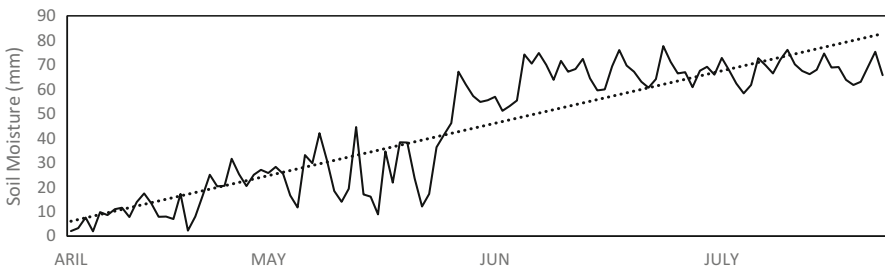


Fig. 2 Trend in the daily soil moisture values observed in 2017 (Oladapo et al. 2018)

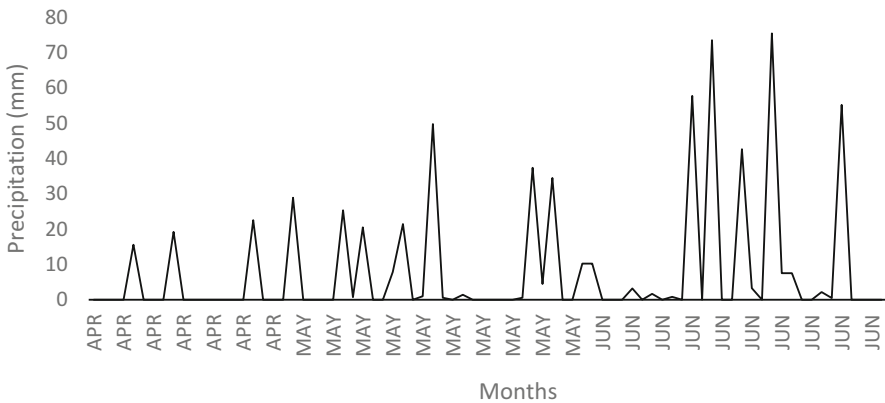
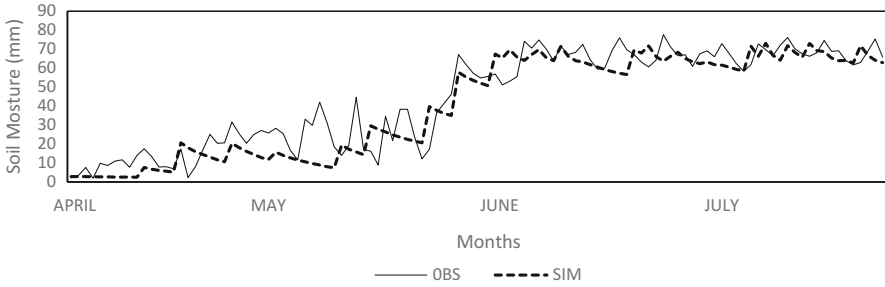
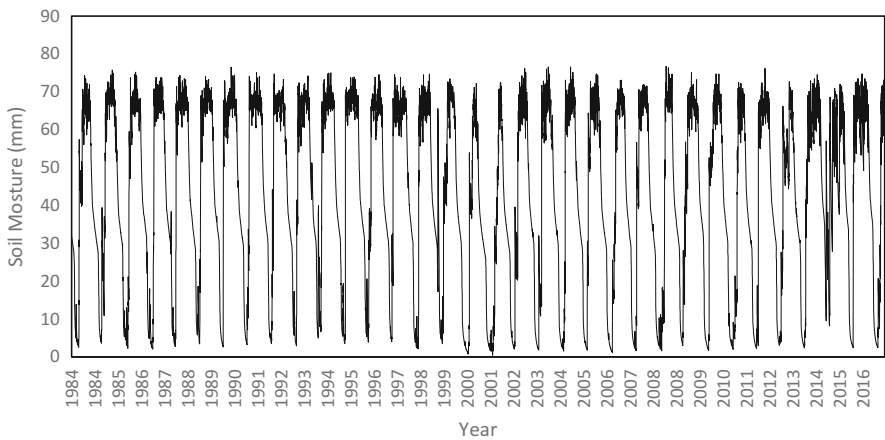


Fig. 3 Precipitation distribution at the watershed during the rainy season in 2017 (Oladapo et al. 2018)



**Fig. 4** Comparison between daily means of observations and SWAT simulated soil moisture (April to July 2017) (Oladapo et al. 2018)

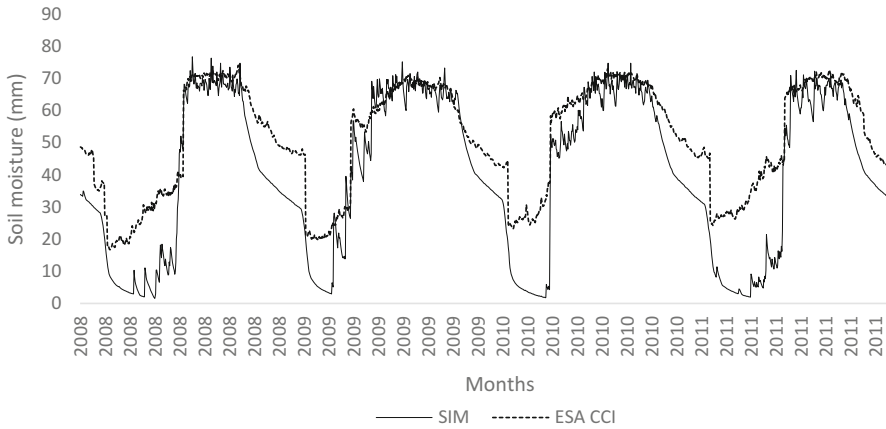


**Fig. 5** The 34-year soil moisture simulated by SWAT over Ogbomoso watershed (Oladapo et al. 2018)

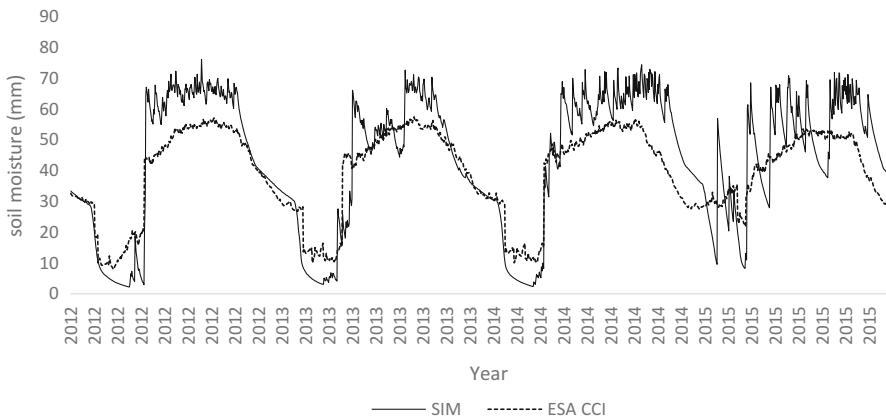
moisture values from the field where the sub-basin is located for this four months period. Figure 4 shows that the model closely follows a similar curve to observed value.

**Soil Moisture Simulation**

The model simulation allows for a 5-year warm-up period. Therefore, a 5-year secondary climate data inputs obtained from NIMET for Ogbomoso metropolis were used for this purpose. The SWAT was used to simulate the soil moisture in the Ogbomoso watershed for 34-year period (1984–2017). Figure 5 shows the temporal variations of soil moisture in the sub-basin of Ogbomoso watershed over the last 34 years. For the 34-year period, the simulated soil moisture declines slightly.



**Fig. 6** Comparisons between daily means of SWAT simulated and ESA CCI soil moistures from January to December between 2008 and 2011 (Oladapo et al. 2018)

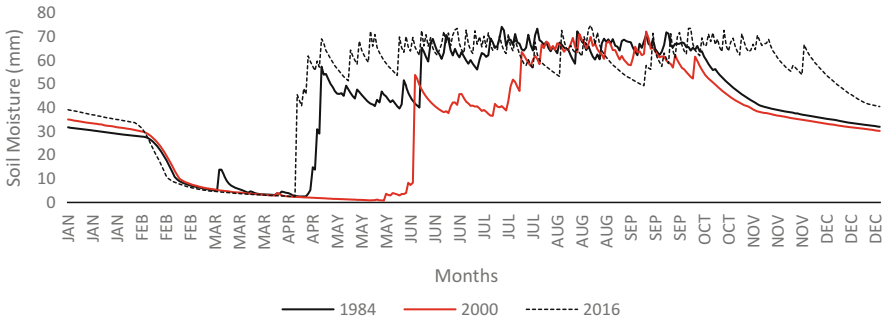


**Fig. 7** Comparisons between daily means of SWAT simulated and ESA CCI soil moistures from January to December between 2012 and 2015 (Oladapo et al. 2018)

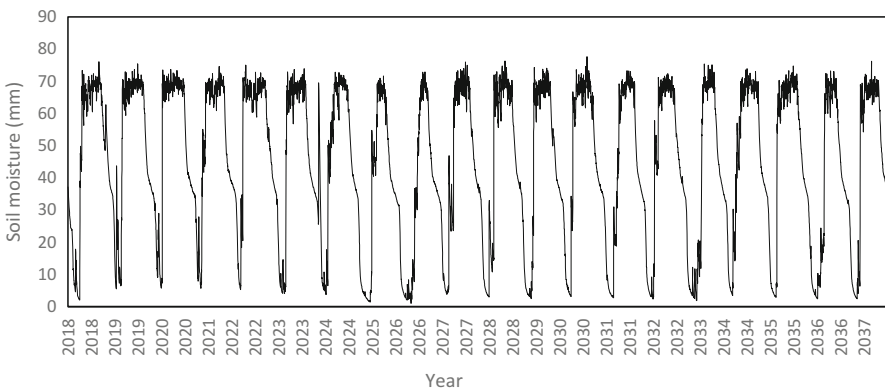
Figure 6 shows the calibration of the simulated soil moisture with the daily satellite-based soil moisture. There was a good correlation between them. The comparison showed a similar pattern when four years (2012–2015) daily simulated soil moisture from the sub-basin was used for validation as shown in Fig. 7.

The noticeable variation between the daily simulated soil moisture and the satellite-based values of ESA CCI in Figs. 6 and 7 could be traced to the physical and hydraulic parameters associated with the soils, such as soil texture and rainfall, and land cover and land management practices in place. Furthermore, the seasonal variations of the SWAT simulated soil moisture for years 1984, 2000, and 2016 were compared as shown in Fig. 8. Seasonal variations investigated for three years at random showed a similar pattern for the years 1984, 2000, and 2016. The soil





**Fig. 8** Seasonal variation of the simulated soil moisture from January to December for year 1984, 2000 and 2016

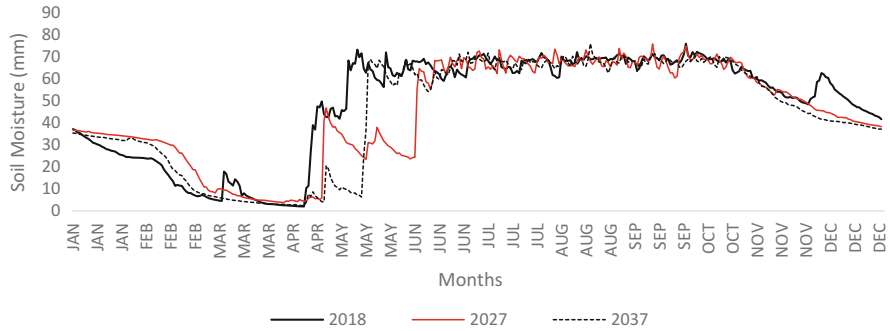


**Fig. 9** The 20-year soil moisture forecasted by SWAT over the Ogbomoso watershed (Oladapo et al. 2018)

moisture declines greatly from January till March when the onset of rainfall begins again. This is largely due to reduction in the air temperature of the region. The soil moisture begins to pick up in April being the onset of the raining season and continues to increase till mid-October when it begins to reduce again. The variation in the simulated soil moisture in Fig. 8 is mainly due to the distribution of precipitation in the area.

**Forecasted Soil Moisture**

The RCP 8.5 projection was used to forecast soil moisture in the region with the assumption of slow growth income and increased population density (Riahi et al. 2011). The RCP 8.5 projection scenario means that there will be increase in the greenhouse gas emission due to the fact that energy is in high demand in the long-term absence of climate change regulations and policies (Riahi et al. 2011). Fig. 9



**Fig. 10** Seasonal variation of the forecasted soil moisture from January to December for 2018, 2027, and 2037 (Oladapo et al. 2018)

shows the temporal variations of forecasted soil moisture in the sub-basin of the Ogbomoso agricultural watershed in the next 20 years (Oladapo et al. 2018). The forecasted soil moisture showed a general drop in trend which may suggest that there is likely to be a decrease in precipitation and a rise in air temperature in the region within the next 20 years.

Seasonal variation of the SWAT forecasted soil moisture in Fig. 10 which bears similar pattern with that of the simulated soil moisture confirms the key role rainfall plays in the quantity of soil water reserve.

## Estimation of Radon Flux Density

The release of radon gas from the soil can take place either by emanation or through the process of transport. The process whereby a  $^{222}\text{Rn}$  atom escapes from  $^{226}\text{Ra}$ -bearing grains to the pore space in soil is called emanation. The process of radon transport, which occurs in the pore space of the soil, involves the process of advection and diffusion. Diffusion is a product of slope in the radon concentration. Meanwhile, the pressure difference between the ground surface and pore space gives rise to advection. In this chapter, the process of diffusion alone will be considered. This is because influence of most meteorological parameters on the advection can be assumed to be negligible when averaged over one month. Provided that soil under investigation is homogeneous, a one-dimensional diffusion equation can be used to derive the radon flux density from the soil within the region (Goto et al. 2008). There is usually a rise in the radon released into the atmosphere when the soil moisture is low leading to an increase in radon flux density from the soil surface. However, when a certain soil moisture is reached, the radon diffusion and advection process is reduced. This is because the pore space being filled with water slows down the radon flux density from the soil surface (Koarashi et al. 2000; Iimoto 2002). The result of this work is similar to other works on the relationship between soil moisture and radon flux density from the earth surface (Koarashi et al. 2000; Iimoto 2002). The

radon flux density values estimated in this work will serve as reference since radon flux data are scarce around the world.

The influence of the soil moisture and soil temperature on the radon flux density is considered. The radon flux density, from the soil surface, was estimated using the UNSCEAR radon flux formula (Zhou et al. 2005).

$$F = R\rho_b \varepsilon \left( \frac{T}{273} \right)^{0.75} \sqrt{\lambda D_o p \exp(-6Sp - 6S^{1.4p})} \quad (1)$$

where  $R$  is the soil  $^{226}\text{Ra}$  content ( $\text{Bq kg}^{-1}$ ),  $\rho_b$  is the soil bulk density ( $\text{kg. m}^3$ ),  $\varepsilon$  is the emanation coefficient of  $^{222}\text{Rn}$  in soil, which is a function of the soil temperature ( $T$ , in Kelvin scale) and the water saturation fraction ( $S$ ),  $\lambda$  is the  $^{222}\text{Rn}$  decay constant ( $\text{s}^{-1}$ ),  $p$  is the soil porosity, and  $D_o$  is the  $^{222}\text{Rn}$  diffusion coefficient in air ( $1.1 \times 10^{-5} \text{ m}^2 \cdot \text{s}^{-1}$ ). The emanation coefficient ( $\varepsilon$ ) of  $^{222}\text{Rn}$  in soil was estimated from the fitted formula of Zhuo et al. (2005).

The values of the soil moisture and soil temperature simulated by SWAT were inputted into the equation. The evaluation result showed that the UNSCEAR radon flux formula performed well in estimating the radon flux density in the study area when calibrated with observed atmospheric radon concentration in the study area. The values of the estimated radon flux density ranged between 4.03 and 37.30  $\text{mBqm}^{-2} \cdot \text{s}^{-1}$  with a mean of 15.09  $\text{mBqm}^{-2} \cdot \text{s}^{-1}$ . The overall average radon flux density in the area lies below the world mean value (UNSCEAR 2000). The mean value of radon flux density in the area indicated that Ogbomoso metropolis is not prone to risk of radon exposure and may not cause any health risk such as lung cancer and other respiratory tract diseases. For this reason, it is safe to conclude that the radon flux density will not have any radiological health risk to the inhabitants of Ogbomoso metropolis. However, field measurements of the radon flux density within and outside of Ogbomoso are needed to further verify the reliability of these estimates. Since there exist insufficient radon flux measurements around the globe, these set of estimated radon flux densities in Ogbomos will serve as baseline data for future references. Note that the estimated radon flux densities within Ogbomoso investigated in this chapter are between the soil and the atmosphere, hence the health risk is very negligible. The health effect of radon exhalation within buildings in Ogbomoso which is expected to be higher may, however, pose some radiological health risk. For this reason, it is important to review the health implication of radon exhalation values which are triggered by climate change within Ogbomoso.

---

## Conclusion

The effects that climate change has on the variation of soil moisture are the focus of this chapter for the purpose of estimating the health effect of radon flux density within Ogbomoso. A 34-year simulation of soil moisture content was executed within Ogbomoso watershed using the hydrological model, Soil Water Assessment

Tool (SWAT). A 20-year forecast of the soil moisture was also done. The calibrated and validated SWAT model performed well for the simulation of daily soil moisture. A general decline in trend was observed for both the simulated and forecasted soil moisture. This decline in trend may be largely due to rainfall reduction and temperature rising in the region. The SWAT model has proven to be suitable for simulating and forecasting soil moisture in the region. The radon flux density for the study area was estimated using the UNSCEAR radon flux formula. The mean value of the radon flux density of  $15.09 \text{ mBqm}^{-2}\cdot\text{s}^{-1}$  falls below the estimated world average of  $33 \text{ mBqm}^{-2}\cdot\text{s}^{-1}$  by UNSCEAR. The result of the estimated radon flux density showed that Ogbomoso region is not prone to high risk of radon exposure to the public. In other words, the estimated radon flux density in the study area will not pose any radiological health risk such as lung cancer or any other respiratory tract diseases to the inhabitant of Ogbomoso metropolis.

**Acknowledgments** This research is supported by funding from the UK's Department for International Development (DfID) under the Climate Impacts Research Capacity and Leadership Enhancement (CIRCLE) program implemented by the African Academy of Sciences and the Association of Commonwealth University.

---

## References

- Abumurad KM, Al Tamimi M (2001) Emanation power of radon and its concentration in the soil and rocks. *Radiat Meas* 34:423
- Adabanija MA, Afolabi OA, Olatubosun AT, Kolawole LL (2014) Integrated approach to investigation of occurrence and quality of groundwater in Ogbomoso North, Nigeria. *Environ Health Sci* 73(1):139–162
- AghaKouchak AA (2014) Baseline probabilistic drought forecasting framework using standardized soil moisture index: application to the 2012 United States drought. *Hydrol Earth Syst Sci* 18:2485–2492
- Ajibade AC, Rahaman MA, Ogezi AEO (1988) The Precambrian of Nigeria, a geochronological survey. Publication of the Geological Survey of Nigeria, pp 313–324
- Alexander L (2011) Climate science: extreme heat rooted in dry soils. *Nat Geosci* 4:12
- Arnold JG, Srinivasan R, Muttiah RS, Williams JR (1998) Large area hydrologic modeling and assessment, Part I: model development. *J Am Water Resour Assoc* 34(1):73–89
- Ball TK, Nicholson RA, Peachey D (1983) Effects of meteorological variables on certain soil gases used to detect buried ore deposits. *Trans Inst Min Metall* 92:B183–B190
- Brookins DG (1990) The indoor radon problem. Columbia University Press, New York, p 229
- Broxton, Xubin Zeng, Damien Sulla-Menashe, Peter A. Troch, (2014) A Global Land Cover Climatology Using MODIS Data. *J Appl Meteorol Climatol* 53 (6):1593–1605
- Chen T, De Jeu R, Liu Y, Van der Werf G, Dolman A (2014) Using satellite based soil moisture to quantify the water driven variability in NDVI: a case study over mainland Australia. *Remote Sens Environ* 140:330–338
- Feng H, Liu Y (2015) Combined effects of precipitation and air temperature on soil moisture in different land covers in a humid basin. *J Hydrol* 531:1129–1140
- Fields RW (2010) Climate change and indoor air quality. Contractor report prepared for U.S. Environmental Protection Agency, Office of Radiation and Indoor Air. pp 1–15
- Gassman PW, Reyes MR, Green CH, Arnold JG (2007) The Soil and Water Assessment Tool: historical development, applications, and future research directions. *Trans ASABE* 50(4):1211–1250

- Goto M, Moriizumi J, Yamazawa H, Iida T, Zhou WH (2008) Estimation of global radon exhalation rate distribution. In: *The Natural Radiation Environment. 8th International symposium (NRE VIII)*. America Institute of Physics, New York, pp 169–171
- Gupta ML, Douglass AR, Kawa R, Pawson S. (2004) Use of radon for evaluation of atmospheric transport models: sensitivity to emissions, *Tellus Series B. Chem Phys Meteorol* 56:404–412
- Iida T, Ikebe Y, Suzuki, k., Ueno, k., Wang, Z., Jin, Y. (1996) Continuous measurements of outdoor radon concentrations at various location in East Asia. *Environ Int* 22(suppl. 1):S139–S147
- Imoto T (2002) Environmental factors varying Rn-220 exhalation rate. In: *Proceedings of the Third Workshop in Environmental Radioactivity*. Tsukuba, pp 189–194, 5–7 Mar 2002. [in Japanese]
- International Commission on Radiological Protection (1993) *Protection against Radon-222 at home and at work*, vol 23. ICRP Publication 65, Annals of the ICRP. Pergamon Press, Oxford
- Koarashi J, Amano H, Iida T (2000) Development of model for water and <sup>222</sup>Rn in unsaturated soil. In: *Proceedings of the 10th International Congress International Radiation Protection Association*, Hiroshima, May 14–19
- Koster RD, Dirmeyer PA, Guo Z, Bonan G, Chan E, Cox P, Gordon C, Kanae S, Kowalczyk E, Lawrence D (2004) Regions of strong coupling between soil moisture and precipitation. *Science* 305:1138–1140
- Kritiz MA, Ronsner SW, Stockwell DZ (1998) Validation of an off-line three dimensional chemical transport model using observed radon profiles. *Int J Geophys Res* 103:8425–8430
- MacDonald AM, Davies J (2000) A brief review of groundwater for rural water supply in sub-Saharan Africa. British Geological Survey Technical Report. W.C./00/33. Natural Environmental Research Council, Nottingham, UK. pp 1–24
- Mazur D, Janik M et al (1999) Measurements of radon concentration in soil gas by CR-39 detectors. *Radiat Meas* 31:295
- McColl KA, Alemohammad SH, Akbar R, Konings AG, Yueh S, Entekhabi D (2017) The global distribution and dynamics of surface soil moisture. *Nat Geosci* 10:100
- Moriyasu DN, Arnold JG, VanLiew MW, Bingner RL, Harem RD, Veith TL (2007) Model evaluation guidelines for systematic quantification of accuracy in watershed simulations, *T. ASABE* 50:850–900
- Neitsch SL, Arnold JG, Kiniry JR, Williams JR (2005) *Soil and water assessment tool (SWAT)*, theoretical documentation. Blackland Research Center, Grassland, Soil and Water Research Laboratory, Agricultural Research Service, Temple
- Ohkura T, Yamazawa H, Moriizumi J, Hirao S, Guo Q, Tohjima Y, Iida T (2009) Monitoring network of atmospheric radon-222 concentration and backward trajectory analysis of radon-222 concentration. *J Jan Soc Atmos Environ* 44(1):42–51. (in Japanese with English abstract)
- Oladapo OO, Amekudzi LK, Oni OO, Aremu AA, Osei MA (2018) Simulation and forecasting of soil moisture content variability over Ogbomoso agricultural watershed using the SWAT model. Official conference proceedings of the European conference on sustainability, energy and environment. *The Internation Academy Forum*. pp 159–173
- Ouyang W, Wu Y, Hao Z, Zhang Q, Bu Q, Gao X (2018) Combined impacts of land use and soil property changes on soil erosion in amollisol area under long-term agricultural development. *Sci Total Environ* 613:798–809
- Riahi K, Rao S, Krey V, Cho C, Chirkov V, Fischer G, Kindermann G, Nakicenovic N, Rafaj P (2011) RCP8.5-A scenario of comparatively high greenhouse gas emissions. *Climate Change* 109:33–57
- Santhi C, Arnold JG, Williams JR, Dugas WA, Srinivasan R, Hauck LM (2001) Validation of the SWAT model on a large river basin with point and nonpoint sources. *J Am Water Resour Assoc* 37:1169–1188
- Schery SD, Whittlestone S, Hart KP (1989) The flux of radon and thoron from Australian soils. *J Geophys Res* 94:8567–8576
- Sheffield J, Wood EF (2008) Global trends and variability in soil moisture and drought characteristics, 1950–2000, from observation-driven simulations of the terrestrial hydrologic cycle. *J Clim* 21:432–458

- Sterling SM, Ducharme A, Polcher J (2013) The impact of global land-cover change on the terrestrial water cycle. *Nat Clim Chang* 3:385
- Tanner AB (1980) Radon migration in the ground: a supplementary review. In: TF Gesell, WM Lowder (eds) *Natural radiation environment III, Symposium proceedings*, Houston, pp 5–56
- United Nation Scientific Committee on the Effects of Atomic Radiation (1993) Sources and effects of ionizing radiation. UNSCEAR 1993 report to general assembly, with scientific annexes, 18. United Nation, New York
- United Nation Scientific Committee on the Effects of Atomic Radiation (2000) Sources and effects of ionizing radiation. UNSCEAR 2000 report to general assembly, with scientific annexes, volume I Sources, Annex B. United Nation, New York, pp 115–116
- Wanders N, Bierkens MF, deJong SM, deRoo A, Karssenberg D (2014) The benefits of using remotely sensed soil moisture in parameter identification of large-scale hydrological models. *Water Resour Res* 50:6874–6891
- Wang T, Ding AJ, Blake DR, Zahorowski W, Poon N, Li YS (2004) Chemical characterization of the boundary layer outflow of air pollution to Honk Kong during February–April 2001. *J Geophys Res* 108(D20):8787
- Wang Y, Yang J, Chen Y, De Maeyer P, Li Z, Duan W (2018a) Detecting the causal effect of soil moisture on precipitation using convergent cross mapping. *Sci Rep* 8:12171
- Wang Y, Yang J, Chen Y, Wang A, De Maeyer P (2018b) The spatiotemporal response of soil moisture to precipitation and temperature changes in an arid region, China. *Remote Sens* 10:468
- Zahorowski W, Chambers CD, Henderson-Sellers A (2004) Ground based Radon-222 observation and their application to atmospheric studies. *J Environ Radioact* 76:30–33
- Zhang K, Wan H, Zhang M, Wang, b. (2008) Evaluation of the atmospheric transport in a GCM using radon measurements; sensitivity to cumulus convection parameterization. *Atmos Chem Phys* 8:2311–2832
- Zhuo W, Iida T, Furukawa M, Guo Q, Kim YS (2005) Soil radon flux density and outdoor radon concentration in East Asia. Elsevier international congress series, vol 1276, p E-285

**Open Access** This chapter is licensed under the terms of the Creative Commons Attribution 4.0 International License (<http://creativecommons.org/licenses/by/4.0/>), which permits use, sharing, adaptation, distribution and reproduction in any medium or format, as long as you give appropriate credit to the original author(s) and the source, provide a link to the Creative Commons license and indicate if changes were made.

The images or other third party material in this chapter are included in the chapter's Creative Commons license, unless indicated otherwise in a credit line to the material. If material is not included in the chapter's Creative Commons license and your intended use is not permitted by statutory regulation or exceeds the permitted use, you will need to obtain permission directly from the copyright holder.





# African Yam Bean the Choice for Climate Change Resilience: Need for Conservation and Policy

# 25

C. V. Nnamani, D. B. Adewale, H. O. Oselebe, and C. J. Atkinson

## Contents

Introduction .....	454
Population Increase and Challenges of Food Security .....	455
Proffering Solution with Neglected and Underutilized Plant Genetic Resources .....	457
African Yam Bean an Underutilized Plant Genetic Resources .....	458
Nutritional Potentials of African Yam Bean for Climate Change Adaptation .....	459
Nomenclatural Etymology of African Yam Bean to Climate Change .....	459
African Yam Bean, the Choice for Climate Change Resilience .....	462
Policy and Conservation African Yam Bean .....	465
Conclusions .....	466
References .....	467

This chapter was previously published non-open access with exclusive rights reserved by the Publisher. It has been changed retrospectively to open access under a CC BY 4.0 license and the copyright holder is “The Author(s)”. For further details, please see the license information at the end of the chapter.

C. V. Nnamani (✉)

Plant Systematics and Conservation Biology Research Unit, Department of Applied Biology,  
Faculty of Science, Ebonyi State University, Abakaliki, Nigeria  
e-mail: [nnamanicatherine@ebsu.edu.ng](mailto:nnamanicatherine@ebsu.edu.ng)

D. B. Adewale

Department of Crop Science and Horticulture, Federal University Oye-Ekiti, Ikole-Ekiti, Nigeria

H. O. Oselebe

Department of Crop Production and Landscape Management, Ebonyi State University, Abakaliki,  
Nigeria

C. J. Atkinson

Natural Resources Institute, University of Greenwich, London, UK

Department of Agriculture, Health and Environment, Natural Resources Institute, University of  
Greenwich, Chatham, UK

e-mail: [c.j.atkinson@gre.ac.uk](mailto:c.j.atkinson@gre.ac.uk); [c.j.atkinson@greenwich.ac.uk](mailto:c.j.atkinson@greenwich.ac.uk)

© The Author(s) 2021

W. Leal Filho et al. (eds.), *African Handbook of Climate Change Adaptation*,  
[https://doi.org/10.1007/978-3-030-45106-6\\_203](https://doi.org/10.1007/978-3-030-45106-6_203)

453

---

**Abstract**

Global warming has emerged as a major challenge to development and human wellbeing in Sub-Saharan Africa in general and Nigeria in particular. Periodic incidents show that this challenge will continue and increase in impact on all aspects of natural resources – agriculture, ecosystems services, biodiversity depletion, environmental degradation and human health. Recognizing the enormous potential of underutilized plant genetic resources (PGRs) is crucial as sources of solutions to a number of these threatening challenges emanating from climate change (food and nutrition insecurity, genetic erosion, loss of agro-biodiversity, green job growth and income generation) cannot be over-emphasized. *Sphenostylis stenocarpa* (Hochst. ex. A. Rich) Harms., commonly known as African yam bean (AYB) belonging to the leguminous Fabaceae, is an underutilized PGR with rich portfolio which could serve as vital source of robust adaption and resilient germplasm for vulnerable local communities in Nigeria. Its substantial nutritional, environmental, cultural, social, medicinal, industrial and soil restorative potentials underpins its position as climate – smart species. Enhancing the potentials of African yam bean via robust innovative approaches for wider utilization through accelerated research, farmer seed exchanges, in-situ and ex-situ conservations, farmers selection, and policy programs such as seed sovereignty will accentuate its adaptation and used as resilient climate –smart species for the vulnerable groups in Nigeria to cushion impact of climate change.

---

**Keywords**

African yam bean · Climate smart species · Adaptation climate change · Resilience · Conservation · Nigeria

---

**Introduction**

The Intergovernmental Panel on Climate Change (IPCC) reported that global warming of 1.5 °C and greater upsurge of 2 °C is projected for 2046–2065 and that these will have consequential impacts on food and water security, health, and other components of sustainable development, limiting strategies for adaptation, losses and damages to biodiversity and ecosystem services (IPCC 2018). All players are potential culprits to these increase, and accordingly need to undertake considerable behavioral changes to counteract this life threatening global warming, particularly in Sub-Saharan Africa. However, the above scenario is dependent on the level of anthropogenic activities on future greenhouse gas emissions (Pachauri and Meyer 2014).

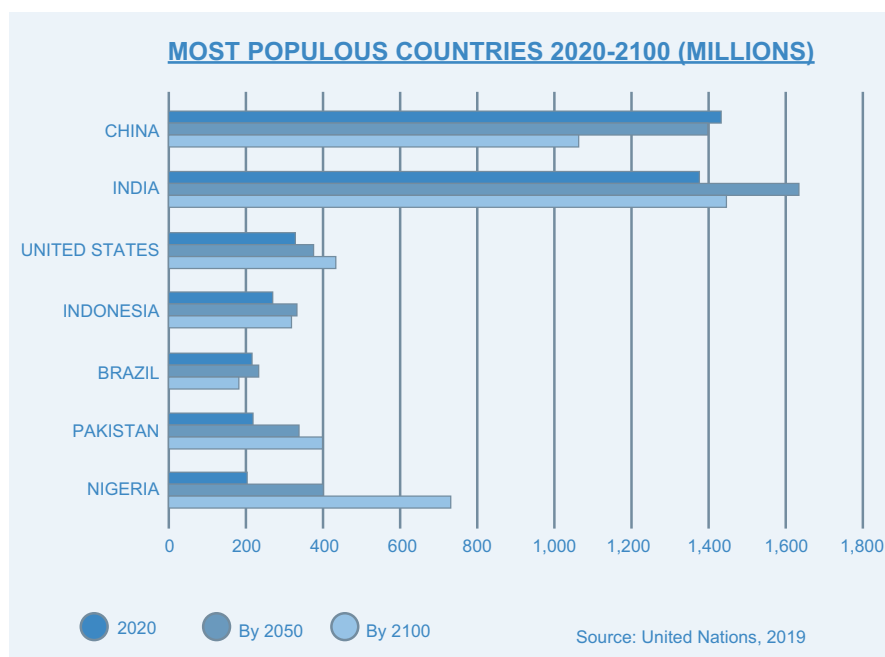
Resilience is required within any systems to deal with climate stresses and disturbances and this include the willingness to change, skills to learn and capacity to adapt to such changes. It is therefore the zeal of managing changes and adaptations that can stand the test of current and future climate risks.



## Population Increase and Challenges of Food Security

There has been a geometric increase in global population over the last 200 years and it is projected to continue to rise. United Nations forecast stated that due to exponential growth, that population will rise from the current 7 billion to reach 9.7 billion by 2050 and subsequently 10.9 billion by 2100 (Fig. 1). This brings with it a number of life threatening challenges, especially in the absence of adequate food production technology, integrated programs which simultaneously address those community needs for food and reproductive health and impact of climate variability and change (World Bank 2014). The consequential effects of this population increase will be greater in Sub-Saharan Africa due to many factors such as, higher fertility rate, demographically younger population entering childbearing life phase, joblessness and a more volatile employment market.

Rapid national population growth has induced and intensified major environmental changes in response to climate change and variability which have led to the emergence of novel pests and diseases, loss of crop genetic diversity and a decline in resources such as water (Dobermann and Nelson 2013). Despite these, current global food production rates being at their highest level, they still fail to match population demand. Given the predicted population increase, food production will need to increase to meet demand by between 59% and 98% by 2050 (Elferink and Schierhorn 2016). United Nations Food and Agriculture Organization (FAO 2010) estimated that about 795

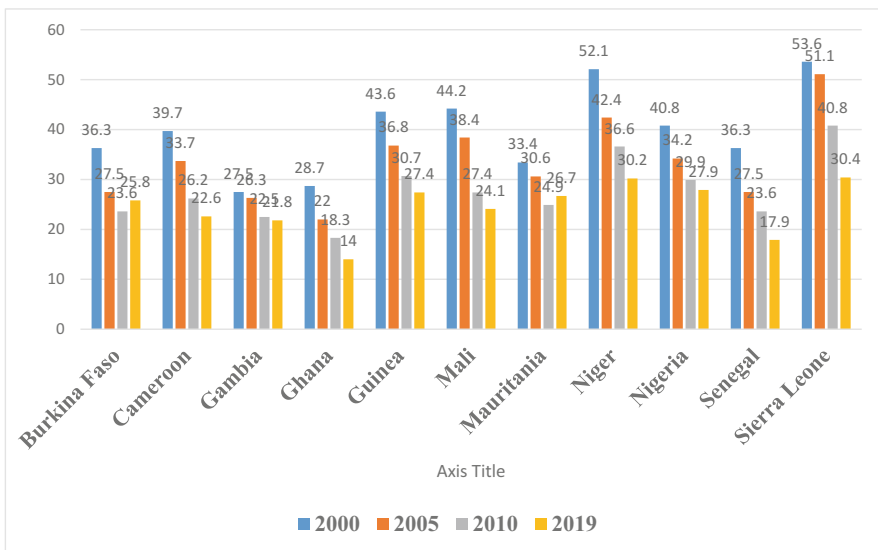


**Fig. 1** Predicted population growth for 2020–2100

million people, of the current 7.3 billion population, suffered chronic malnourishment between 2014 and 2018 and majority of these people lived in developing countries. The Global Hunger Index (Grebmer et al. 2019) shows that multiple countries have higher hunger levels now than in 2010, and approximately 45 countries in current reality will not be able to achieve lower levels of hunger by 2030.

Poor monotonous diets, low in calorific quantity and quality with respect to nutritional level, variety and diversity are the primary cause for poor human health in many developing countries. Coincidentally, while the number of mouths to feed is increasing more rapidly than those farmers who are able to produce food. Hunger, malnutrition and famines and many endemic diseases, desertification, and floods continue to pose high risks in developing countries with low resilience which will be further exacerbated by climate change and climate variability aboard (Dobermann and Nelson 2013).

Nigeria ranks 93rd out of 117 qualifying countries with a score of 27.9, showing that its population is malnourished with high number of hungry people. This is an indication that out of the 162.5 million people, 1 in every 7 go to bed hungry (Grebmer et al. 2019). Mary Robinson, an Adjunct Professor of Climate Justice, Trinity College Dublin and former UN High Commissioner for Human Rights stated that “it is a terrible global indictment that after decades of sustained progress in reducing global hunger, climate change and conflict are now undermining food security in the world’s most vulnerable regions.” She concluded that with the number of hungry people rising from 785 million in 2015 to 822 million in 2018, “we can no longer afford to regard the 2030 Agenda and the Paris Climate Agreement as voluntary. This could be inferred from the level of changes over time in West Africa (Fig. 2). The above scenario needs vital actions and collective change of



**Fig. 2** West Africa Global Hunger Index scores, and changes over time. (Source: Grebmer et al. 2019)

attitude at both global and local levels in order to secure a habitable world for our forthcoming generations” (Grebmer et al. 2019).

---

## **Proffering Solution with Neglected and Underutilized Plant Genetic Resources**

Plant genetic resources (PGR) are those varieties of heritable materials confined in traditional selections and modern domesticated cultivars together with their wild relatives and other wild plant species locally used as food, feed for domestic animals, fibre, clothing, medicine, shelter, wood, timber, energy and for recreational activities.

Neglected and underutilized plant genetic resources are domesticated and wild plants species which have been used for centuries as sources of food, fibre, fodder, oil, or have medicinal properties (stimulants, narcotics, aromatics), but their importance has remained unharnessed, abandoned, replaced with exotic foods or only very slowly now being considered for use. They are known by various names, including orphan, abandoned, lost, forgotten, neglected, underutilized, local, minor, poor man’s food, traditional, alternative, niche, or underdeveloped plants (Padulosi 2017). Their underutilized potentials can be significantly exploited to combat climate change, as a future “smart crop” to improve food and nutrient insecurity. Here we adopt a progressive and positive approach to their potential exploitation as a source of “smart food,” with an emphasis on their exploitation and/or development into viable future crops which are climate resilient. The Global Facilitation Unit for Underutilized Species (Bhat and Taiwo 2015) defines these species, as those with a potential not fully exploited; with respect to contributing to food security and poverty alleviation, combined with their strong links to local community cultural heritage. Their limited or poor documentation by research are evidenced by their adaptation to specific agro-ecological niches, a weak or non-existent seed supply systems, fully in the domains of traditional users only. They are produced with little, or no external inputs.

Our ancestors used over 7000 plant genetic resources (PGRs) as food, from which farmers produced about 70% of the global food supply (Bhat and Taiwo 2015). Currently, very few of these PGRs are still exploited in sustaining humans. Making food and nutrient security dependent on a handful of crops with 65% requirements for protein, calories and minerals met by wheat, rice, yam and cassava (FAO 2017). This shrinking portfolio of PGRs, shifts in life style, and the preference for fast foods are currently contributing factors involved in food and nutrient insecurity. These are reducing the capacity of farmers to adapt to changing markets, to innovate, to develop supply chains, and our ability to cope with climate change variability and its extremities (IPGRI 2003). Recognizing the considerable potentials which underutilized PGR can provide is crucial in finding solutions to the impacts of climate change on food and nutritional insecurity, genetic erosion, conservation of agro-biodiversity, green growth jobs and income generation (Padulosi et al. 2013; Nnamani 2015).

Nigeria as a nation holds a rich variety of PGRs linked to food, and other treasured traits. However, most of these species have received little, or no attention with respect to support for basic research, breeding improvement, commercial exploitation of germplasm selections, or consideration by policy itineraries to

support enhanced utilization, thereby leaving them neglected. In order to meet food security challenges for a growing population under changing climate, it is necessary to identify and valorize these neglected and underutilized species (NUS) to develop greater resilience within local communities and the adaptation potential to increasing climate unpredictability and change.

### African Yam Bean an Underutilized Plant Genetic Resources

*Sphenostylis stenocarpa* (Hochst. ex. A. Rich) Harms, customarily called African yam bean (AYB), is a legume of the subfamily Faboideae and family Fabaceae. *Sphenostylis* as a genus is represented by only 7 species (Potter and Doyle 1992). African yam bean is an orphan crop cultivated and utilized by local communities. It is a climbing annual, prostrate, or erect and approximately 1–3 m tall. The leaves are trifoliate, about 2.7–13 cm long and 0.2–5.5 cm broad. The inflorescence could be a raceme which shows an acropetal variety of flowering with pink colour intermingled with purple, twisted backward characteristics of the Fabaceae family (Fig. 3).

African Yam Bean is synonymous with African continent only, its geographical distribution is tolerated mainly within the soil, climate, and vegetation of Africa especially within the range of latitudes 15° North to 15° South and longitudes 15° West to 40° East (Adewale et al. 2008). The above geographical range could be referred to as the center of diversity of AYB (Fig. 3) since there is no record of the origin of the crop in any other continent beyond Africa (Potter and Doyle 1992). It is a crop of African origin, made for Africans and utilized as such in Africa, hence this



**Fig. 3** Growth habit, floral and fruits features of African yam bean. (Photo © Adewale, B. D. and Nnamani, C. V.)

confirming the common claim that the crop is a tropical African legume. The rich hot spots of *S. stenocarpa* is found in Chad and Ethiopia in northeast tropical Africa, Kenya, Tanzania and Uganda for east tropical Africa, and in Burundi, Central African Republic and Zaire for west-central tropical Africa. It is also found in West Africa in places like Cote d'Ivoire, Ghana, Guinea, Mali, Niger, Nigeria and Togo while in south tropical Africa it is cultivated in Angola, Malawi, Zambia and Zimbabwe (USDA Agricultural Research Service 2015) (Fig. 4).

In South-east, Nigeria, the plant is diverse in distribution and geographical range thriving more in the derived savanna vegetation zone (Fig. 5).

---

## Nutritional Potentials of African Yam Bean for Climate Change Adaptation

The seeds and tubers of AYB are highly rich in protein, minerals, and vitamin (Fig. 5). It is a promising source of plant protein for resource poor rural and semi-rural communities. The amino acid (lysine and methionine) has been reported to be higher than those of pigeon pea, cowpea, and bambara groundnut (Uguru and Madukaife 2001). Omeire (2012), noted that the amino acid ( $\text{g } 100^{-1} \text{ g}$ ) profile of AYB comprised of lysine (6.1), histidine (3.1), arginine (6.5), aspartic acid (9.1), glycine (3.9), alanine (4.1), valine (5.0), and phenylalanine (5.1) (Fig. 5). Its lysipne and methionine contents were similar or better than those of soybean protein (Yetunde et al. 2009) and comparable with whole chicken eggs (Ekpo 2006). The protein profile of the tubers compares favourably with that of other African root crops such as yams and sweet potatoes and has almost two and half times the protein value of cassava tubers (National Research Council 1979; Amoatey et al. 2000; Adewale and Aremu 2013) (Fig. 6).

African yam bean is cultivated for its edible seeds and tubers (Fig. 7), which have sustained indigenous community's livelihoods. A report of its medicinal value was reported in a traditional Igbo settings at Enugu State, Nigeria. The seed is an important ingredient utilized in the topical treatment of stroke, insomnia, diabetics, measles and stress. Extract of mashed AYB, after cooking, is used to induce lactation in mothers after child birth, while the fried seed coat is ground and used in the treatment of stroke (Nnamani et al. 2017). Culturally, it is used traditionally to entertain guests during traditional marriage ceremonies and serves as a famine food when every other crops have failed. Industrially, African yam bean flour is used to fortify conventional wheat flour which is frequently lower in protein content (Nnamani et al. 2017).

---

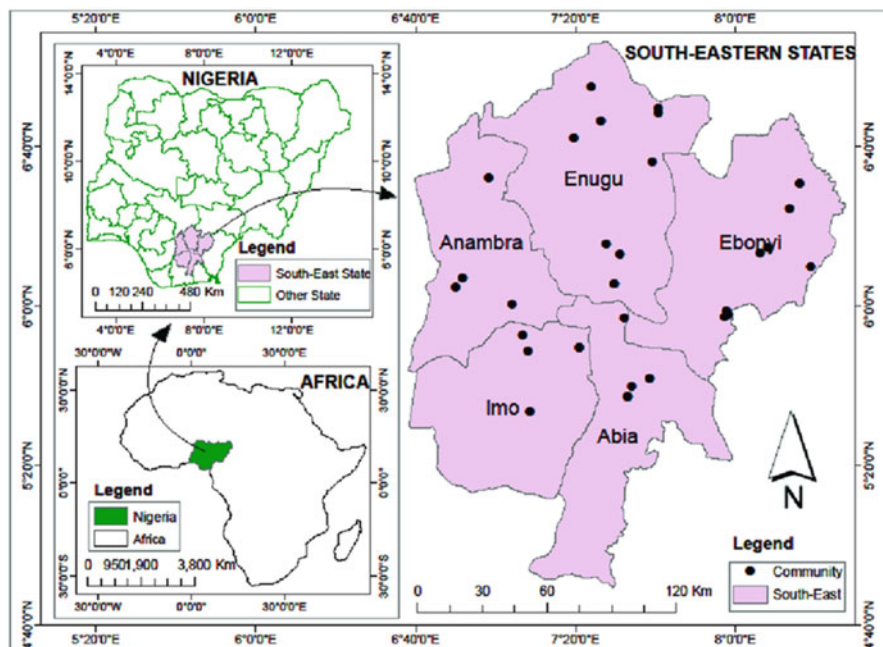
## Nomenclatural Etymology of African Yam Bean to Climate Change

*Sphenostylis stenocarpa* is botanically synonyms in numerous literatures with *Sphenostylis ornata* A. Chev., *Sphenostylis congensis* A. Chev., *Dolichos stenocarpus* Hochst. ex. A. Rich., *Sphenostylis katangensis* (De Wild.) Harms, *Vigna katangensis* De Wild., and *Vigna ornata* Welw. ex. Baker. However, the



**Fig. 4** Center of diversity of African Yam Bean in Africa. (Source: USDA Agricultural Research Service 2015)

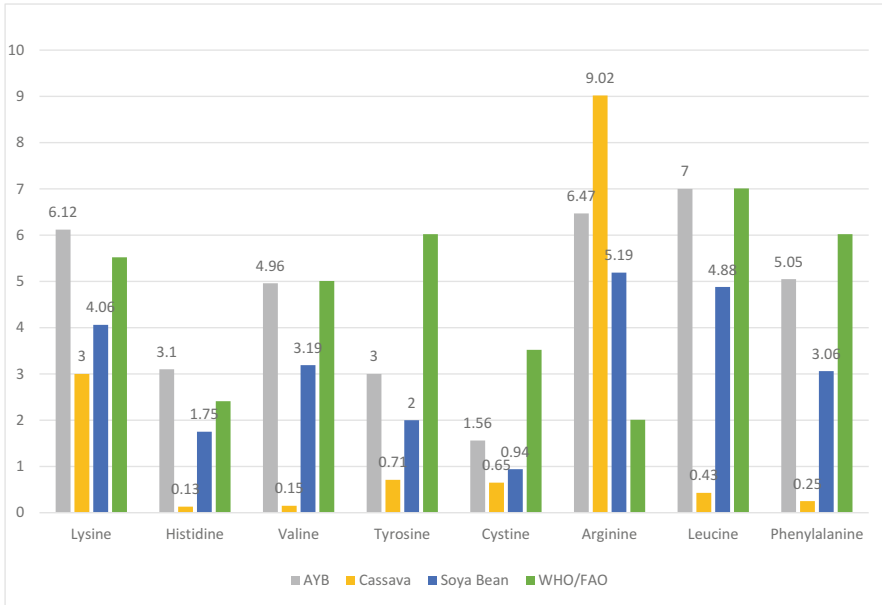
current acceptable nomenclature is *Sphenostylis stenocarpa* (Hochst. ex. A. Rich) Harms (Adewale et al. 2012). Key (1989) reported the followings common names as “Diegemtenguere” (Mali), “Girigiri” (Hausa, West Africa), “Norouko” and/or “Roya” (Sudan). Adewale and Odoh (2013) reported on some of the tribal synonyms of the crop in Nigeria: it is known as “Azama” (Ebonyi, State), “Akidi” or “Azima” or “Okpududu” (Ohafia, Abia State) and “Uzaaku” or “Ijiriji” (Nsukka, Enugu State)



**Fig. 5** Geographical distribution of African yam bean in south-east Nigeria. (Source: Nnamani et al. 2017)

in Igbo land; it is “Ewe” (Ijesha, Osun State), “Otili” (Ekiti, Ekiti State), “Ekulu” (Ipe-Akoko, Ondo State), “Orogodo” (Owo, Ondo State), “Peu” (Ijebu, Ogun State) and “Sunmunu” (Iseyin, Oke-Ogun, Oyo State), Yoruba land. Some other tribal names for AYB in Nigeria are “Ihiehie” (Ishan, Edo State), “Iye” (Estako, LGA, Edo State), “Ahuma” (Tiv, Benue State), “Nsama” (Efik-Ibibio, Akwa Ibom) and Cross River State) (Adewale and Odoh 2013).

Al Azharia (2006) noted that throughout human history, folk nomenclature has been the underpinning factor for plant selection, improvement and conservation. It was and still is customarily for the local custodians to recognized species which have accomplished high serviceable and cultural values by custodians of such plants worldwide. When folk names given to species it often carries etymological meaning such as healing effects, morphological features, mythical connotations, adaptive strength, mitigating capability and allegorical values (Nnamani et al. 2019). Etymological data showed the AYB had sustained the lives of the local communities for ages. Indigenous lingual synonyms for AYB in Nigeria have etymological significances relating to how this crop had interfaced with the livelihood and environmental conditions of the local communities in different scenarios in the past (Table 1). These names often convey relationships to specific plant therapeutic effects, nutritional capacity, morphological features, mythical connotations, and ecological conditions playing out at a particular point in time in their environs (Leyew 2011; Rankoana 2012).



**Fig. 6** Amino acid profile of African yam bean compared with other crops and WHO/FAO benchmarks. (Source: Omeire 2012)



**Fig. 7** Seeds and tuber of African yam bean. (Photo © Nnamani, C. V. and Adewale, B. D.)

### African Yam Bean, the Choice for Climate Change Resilience

“Neglected and Underutilized species (NUS)” are plant species which are sidelined, ignored or completely underexploited, by researchers, breeders and policy makers. They have great prospects to improve people’s livelihoods, guaranteeing food security and self-sufficiency to the users. Their environmental restoration ability are not yet fully appreciated due to their limited competitiveness with fundamental



**Table 1** Etymology of African yam bean in South-east, Nigerian

S/ no.	Ethnic group	Name	Meaning	Etymological facts
1	Izzi	Azama	Feeder of people in hard times (mitigating food)	They believed that God had answered their prayer by giving them this crop to feed them when other crops have failed in the land
2	Ezza	Azama	Healing food for the people (medicine)	In the past when kwashiorkor (malnutrition/hidden hunger) was the major problem facing the people of Ezza, boiling the crop, eating AYB and the use of water from the cooked seeds to bath provides healing
3	Ikwo	Azaaki	Multiple seed-food provider (resilient seed)	They named AYB Azaaki because of the multiple food types it provides, which help poor farmers when they cultivate the crop. They believe that cultivating AYB is a way of avoiding hunger
4	Ngbo	Azaakuru	Plant small and harvest plenty (dominating and climate-smart crop)	Aza-akuru because, it is a passive crop but when planted, it will dominate the whole farm and yield lots of food types both seed and the tuberous root. A dominating crop that God gave to help poor farmers during famine
5	Ntezi and okpoto	Etiti	“Subduer of hunger” (the central hungry killer)	They believed that God has given them the crop to feed them during a time of famine. AYB is the only crop that can feed people even when the quantity is small
6	Afikpo	Azuma	Food server God and medicine	They name this crop Azuma because of its great feeding capacity and its ability to stop some illness, e.g., stomach disorder. They believed that God answered their prayer in times past
7	Ohozara	Aza-ama	Dominating food crop God and medicine	Prayer answered by God for the crop provides food even when other crops have failed. It yields great food for the poor. When the poor cannot cultivate other crops as a result of environmental changes

(continued)

**Table 1** (continued)

S/ no.	Ethnic group	Name	Meaning	Etymological facts
8	Nkalagu	Azaku	Food helper of the poor	They called it “Azaku” because of the role it played during famine in times past. They believed that God provided it to help the poor through its simplicity in cultivation and survival
9	Ohafia- Agba	Azama	Feeder of people Adaptation to climate change	They believed that the God of harvest has provided this crop to sustain his people when other crops do not perform very well on the farm. AYB can compete in and adapt to many difficult environments
10	Agba, Nkalegu and Igboasa	Eriwa	Minor crop that feeds many people Gender	It’s a women’s crop that helps to sustain the women’s little income when the major crops (the men’s crops like yam, rice and cassava) are finished in the bans, particularly after planting. AYB is usually intercropped with other crops by women hence it is termed women’s crop
11	Esza and Ikwo	Onyiaoduru	Sustainer and friend of the farmer Sustainer	Respondents believe that after eating AYB, the consumer keeps drinking water through the day and it gives sufficient energy to work without getting exhausted
12	Ngbo and Izzi	Mgbadamue	Saving seed Seed	When labourers are hired to work on farms. They eat the food in the morning and it will keep them active until evening

Source: Nnamani et al. (2019)

crops in conventional use. Although their potential may not be fully realized at national or international levels, they are of significant importance locally, because of their high adaptation capacity to marginal, complex, and difficult environments contributing significantly to diversification and resilience of agroecosystems (Padulosi et al. 2011).

Shyam et al. (2014) stated that climate modeling is the commonest approach used today for predicting the responses of species to climate change. Species which have resilience biotic characteristics are often informative when used in climate modelling and underutilized plants frequently have an array of stress resistance traits. They are of significant importance locally, highly adaptable to marginal soil, complex and changing environments and agriculturally degraded land. They are hubs contributing meaningfully to diversification and resilience to community agro ecosystems, this is because of their long-standing use with little, or no, conventional breeding

improvement. As orphan crops, notwithstanding their intrinsic low-yield potential, they still have the capacity of resisting climate stresses, having been selected and exploited in local climate stress adaptation within the local communities for generations. In this regard, underutilized PGR could contribute to further building of community resilience over the long-term in response to impending climate change adaptation after effective valorization of a PGR's potential (Mabhaudhi et al. 2019).

African yam bean usefulness as a climate smart species for communities to achieve resilience to climate stresses is based on its ability to survive and even thrive (reliable yield annually) in marginal soils and environments where other crops fail in the absence of often unavailable resources, such as nitrogen fertilization and adequate irrigation. AYB, as a legume, improves soil quality and function through its beneficial effects on soil biological, chemical and physical attributes. Such benefits include enabling improvements in crop N-supply, increasing soil organic matter reserves, stimulating soil microbial diversity and activity, and improvements in soil structure, reducing soil erosion while increasing soil aeration and enhanced soil water-holding capacity. AYB is suitable for wide climatic conditions (Anochili 1984; Betsche et al. 2005) and nitrogen fixation (Oganale 2009; Tettey 2014). Ojuederie and Balogun (2019) obtained better tuber production from genotypes in a year with lower rainfall and sunshine hours. This is a display of smart features.

---

## Policy and Conservation African Yam Bean

Intergovernmental Panel on Climate Change (IPCC 2018) reported the likely consequences of rapid global climatic change on species and their habitats. Such changes could cause a shift in the conservation status of so many species, pushing some towards the red line list of International Union for Conservation of Nature (IUCN). African yam bean has not received much conservation attention to date. Currently, much of its germplasm is in the hands of the local custodians as landraces (Nnamani et al. 2018), while the Genetic Resources Centre at the International Institute of Tropical Agriculture (IITA), Ibadan, Nigeria also hold some quantity of AYB germplasm. The disadvantages of poor conservation technology include the limited access to germplasm by researchers, breeders and farmers, the vulnerability of AYB to natural disasters, genetic erosion and loss of crop diversity are there.

Enhancing the potentials of African yam bean by policy via robust innovative approaches for wider utilization through accelerated research, farmer seed exchanges, in-situ and ex-situ conservations, farmers selection, and policy programs such as seed sovereignty will accentuate its adaptation and used as resilient climate – smart species for the vulnerable groups in Nigeria to cushion the impact of climate change.

These species may be conserved in-situ or ex-situ for future generations. On-farm (in-situ) techniques have several advantages compared with ex situ conservation, as the former allows for evolution of traits through continued natural and human-driven

selections, which will contribute to greater crop adaptation and resilience to abiotic climate stress (Padulosi 2017).

Through the recognition of its promising nutritional potentials, policy could be synchronized in the conservation, promotion, marketing network and utilization of AYB by mainstreaming it into various dietary menus and products to include a range of food products appropriate for a broad range of consumption opportunities. This should include a rebranding of its nomenclature from “poor man’s food” to a more widely acceptable range of producers, retailers and consumers. Decision makers could equally support the development of value chains, scale up development collaborations and information sharing of AYB among researchers, conservationists, breeders, extension workers, farmers, farmer organizations, vendors and NGOs.

Finally, there is need for policy to intensify efforts to support research on the conservation of *S. stenocarpa* through participatory engagement between the species custodians of the species for both in situ and ex situ conservation approaches. Globally the exploitation and development of legumes, which are climate resilient, will provide a significant opportunity for improving human health through integration into food-systems as a replacement, or partial replacement, of current animal sourced proteins. A programmed germplasm conservation approach is needed to collect, characterize, develop and exploit existing diversity in the provision of food, feed, nutritional security and environmental resilience.

---

## Conclusions

Convincingly, recognizing the potential of AYB as an excellent climate smart species through active food governance policy would initiate novel business opportunities by changing the narrative via:

- (i) Scaling up programs on the use of African yam bean in its various dietary forms and consumptions routes. This could rebrand the nomenclature of the species from “poor man’s food” to an added value nomenclature (high protein source).
- (ii) Organizing regular retailer food fairs to showcase various dietary menus accruing from AYB will encourage its selection and consumption by the publics.
- (iii) Support the development of value chains and market networks for small agribusinesses for priority crops such as AYB.
- (iv) Provide credit facilities and farmer/user-friendly technologies to the crop custodians to accelerate production.
- (v) Promote the use of AYB through directed awareness campaigns on the nutritional benefits of the crop.
- (vi) Exploit the offsetting potential AYB consumption of added value of this nutritious crop against the probable reduction in government health budget associated with alleviating malnutrition and it related conditions.

- (vii) Including policy programs that enhance the selection of quality AYB seed available to farmers, with respect to climate resilience.
- (viii) AYB will require more attention firstly, research-based, then technological germplasm development and subsequently supporting exploitation policy and markets. This will direct and facilitate appropriate solutions to major constraints for greater AYB cultivation and utilization.
- (ix) Scaling up development via policy programs has the prospect of empowering resource poor communities who are predominantly women and the unemployed.
- (x) Promote direct and appropriate consumer lead engagement and communication between knowledge acquirers and exploiters to drive AYB germplasm conservation.
- (xi) Innovative biotechnological tools should be used to catalyze transformative change in AYB to promote its selection as a major staple food through a broad food product base.

**Acknowledgements** This work was supported by the CIRCLE Visiting Fellowship Program funded by UK Department for International Development (DfID). Neither the findings nor the views expressed, however, necessarily reflects the policies of UK Government.

---

## References

- Adewale BD, Aremu CO (2013) The Nutritional Potentials and Possibilities in African yam bean for Africans. *Int J Agric Sci* 3(1):8–19
- Adewale BD, Odoh NC (2013) A review on genetic resources, diversity and agronomy of African yam bean (*Sphenostylis stenocarpa* (Hochst. ex. A. Rich.) Harms): a potential future food crop sustainable. *Agric Res* 2:3–43
- Adewale BD, Kehinde OB, Odu BO, Dumet DJ (2008) The potentials of African yam bean (*Sphenostylis stenocarpa* Hochst. ex. A. Rich.) Harms in Nigeria: character distribution and genetic diversity. In: Smart J, Haq N (eds) *New crops and uses: their role in a rapidly changing world. Centre for underutilized crops*. RPM Print & Design, Chichester, pp 265–276
- Adewale BD, Dumet DJ, Vroh-Bi I, Kehinde OB, Ojo DK, Adegbite AE, Franco J (2012) Morphological diversity analysis of African yam bean and prospects for utilization in germplasm conservation and breeding. *Genet Res Crop Evolut* 59:927–936
- Al Azharia J (2006) How Plant Names Reveal Folk Botanical Classification, Trade, Traditional Uses and Routes of Dissemination (II), in *Asian Studies*. *Int J for Asian Stud* 7:77–128
- Amoatey HM, Klu GYP, Bansa D, Kumaga FK, Aboagye LM, Bennett SO, Gamedoagbao DK (2000) African yam bean (*Sphenostylis stenocarpa*): a neglected crop in Ghana. *West Afr J App Ecol* 1:53–60
- Anochili BC (1984) *Tropical agricultural handbook*. In: *Food crop production*. Macmillan Publishers, London, pp 48–50
- Betsche T, Azeke M, Buening-Pfaue H, Fretzdorff B (2005) Food safety and security: fermentation as a tool to improve the nutritional value of African yam bean. In: *Conference proceeding of the international agricultural research for development, Stuttgart–Hohenheim, October 2005*, pp 1–5
- Bhat JA, Taiwo S (2015) Plant genetic resources and traditional knowledge in light of recent policy developments. In: Salgotra R, Gupta B (eds) *Plant genetic resources and traditional knowledge for food security*. Springer, Singapore

- Dobermann A, Nelson R (2013) Opportunities and solutions for sustainable food production, background research paper. High-level panel of eminent persons on the post-2015 development agenda. [www.post2015hlp.org/wp-content/uploads/2013/05/Doberman-Nelson\\_Solutions-for-Sustainable-Food-Production.pdf](http://www.post2015hlp.org/wp-content/uploads/2013/05/Doberman-Nelson_Solutions-for-Sustainable-Food-Production.pdf)
- Ekpo AS (2006) Changes in amino acid composition of African yam beans (*Sphenostylis stenocarpa*) and African locust beans (*Parkia filicoida*) on cooking. *Pak J Nutr* 5:254–256
- Elferink M, Schierhorn F (2016) Global demand for food is rising. Can we meet it?. *Harvard Business Review*. [https://www.researchgate.net/publication/302466629\\_Global\\_Demand\\_for\\_Food\\_Is\\_Rising\\_Can\\_We\\_Meet\\_It](https://www.researchgate.net/publication/302466629_Global_Demand_for_Food_Is_Rising_Can_We_Meet_It)
- FAO (2010) The State of Food Insecurity in the World Addressing food insecurity in protracted crises. Rome. <http://www.fao.org/3/a-i1683e.pdf>
- Food and Agricultural Organization of the United Nations (FAO) (2017) The state of food insecurity in the world 2017. FAO, Rome
- Germplasm Resources Information Network (GRIN) (2009) GRIN taxonomy for plants (online)
- Grebmer K, Bernstein J, Mukerji K, Patterson F, Wiemers M, Ni Chéilleachair R, Foley C, Gitter S, Ekstrom K, Fritschel H (2019) Global Hunger Index: The Challenge of Hunger and Climate Change. Bonn: Welthungerhilfe; and Dublin: Concern Worldwide
- International Plant Genetic Resources Institute (IPGRI) (2003) Annual report. International Plant Genetic Resources Institute (IPGRI), Rome. ISBN 92-9043-591-7
- IPCC (2018) Summary for policymakers. In: Masson-Delmotte V, Zhai P, Pörtner HO, Roberts D, Skea J, Shukla PR, Pirani A, Moufouma-Okia W, Péan C, Pidcock R, Connors S, Matthews JBR, Chen Y, Zhou X, Gomis MI, Lonnoy E, Maycock T, Tignor M, Waterfield T (eds) Global warming of 1.5 °C. An IPCC special report on the impacts of global warming of 1.5 °C above pre-industrial levels and related global greenhouse gas emission pathways, in the context of strengthening the global response to the threat of climate change, sustainable development, and efforts to eradicate poverty. World Meteorological Organization, Geneva, p 32
- Keay RWJ (1989) Trees of Nigeria. Clarendon Press/Oxford University Press, New York, p 476
- Leyew Z (2011) Wild plant nomenclature and traditional botanical knowledge among three ethnolinguistic groups in northern Ethiopia, Ossa edn. Ossa, Addis Abba
- Mabhaudhi T, Chimonyo V, Hlahla S (2019) Prospects of orphan crops in climate change. *Planta* 250:695–708. <https://doi.org/10.1007/s00425-019-03129-y>
- National Research Council (1979) Tropical legumes: resources for the future. National Academy of Sciences, Washington, DC, p 246
- Nnamani CV (2015) Innovative stride to zero hunger beyond 2015 in Nigeria. *Recent Pat Food Nutr Agric* 7:14–21
- Nnamani CV, Ajayi SA, Oselebe HO, Atkinson CJ, Igboabuchi AN, Ezigbo EC (2017) *Sphenostylis stenocarpa* (ex. A. Rich.) Harms., a fading genetic resource in a changing climate: prerequisite for conservation and sustainability. *Plants* 6:30. 1–16. <https://doi.org/10.3390/plants6030030>
- Nnamani CV, Ajayi SA, Oselebe HO, Atkinson CJ, Adewale DB, Igwe DO, Akinwale RO (2018) Updates on nutritional diversity in *Sphenostylis stenocarpa* (Hoechst ex. A. Rich.) Harms., for food security and conservation. *Am J Agric Biol Sci* 13:38–49. <https://doi.org/10.3844/ajabssp.2018.38.49>
- Nnamani CV, Atkinson CJ, Ejike JE (2019) Etymology of folk nomenclatures for *Sphenostylis stenocarpa* (Hoechst ex. A. Rich.) Harms. *J Underutil Legum* 1(1):135–147
- Oganale, D. (2009). Nodulation and nitrogen fixation of African yam bean (*Sphenostylis stenocarpa*). In: Proceedings of African Crop Science Society conference, Cape Town, 28 September–1 October 2009. Science and technology supporting food security in Africa
- Ojuederie OB, Balogun MO (2019) African yam bean (*Sphenostylis stenocarpa*) tubers for nutritional security. *J Underutil Legum* 1(1):56–68
- Omeire GC (2012) Amino acid profile of raw and extruded blends of African yam bean (*Sphenostylis stenocarpa*) and cassava flour. *Am J Food Nutr* 2:65–68
- Pachauri RK, Meyer LA (2014) IPCC climate change 2014: synthesis report. Cambridge University Press, Cambridge
- Padulosi S (2017) Bring NUS back to the table! GREAT insights Magazine 6(4):21–22. <https://hdl.handle.net/10568/89038>

- Padulosi SN, Heywood V, Hunter D, Jarvis A (2011) Underutilized species and climate change: current status and outlook. In: Yadav SS, Redden RJ, Hatfield JL, Lotze-Campen H, Hall AE (eds) Crop adaptation to climate change. Wiley-Blackwell, Oxford, pp 507–521. <https://doi.org/10.1002/9780470960929.ch35>
- Padulosi S, Bergamini N, Lawrence T (2013) On farm conservation of neglected and underutilized species: status, trends and novel approaches to cope with climate change. In: Proceedings of an international conference of biodiversity international, Frankfurt, 14–16 June, 2011. Biodiversity International, Rome
- Potter D, Doyle JJ (1992) Origin of African yam bean (*Sphenostylis stenocarpa*, Leguminosae): evidence from morphology, isozymes, chloroplast DNA and linguistics. *Econ Bot* 46:276–292
- Rankoana SA (2012) The use of indigenous knowledge for primary health care among the Northern Sotho in the Limpopo Province. Unpublished Ph.D. thesis, University of Limpopo, Sovenga
- Shyam SS, Zachariah PU, Kripa V, Mohan A, Ambrose TV, Manju RS (2014) Vulnerability assessment of coastal fisher households in Kerala: a climate change perspective. *Indian J Fish* 61:99–104
- Tetty A (2014) Nodulation, nitrogen fixation and diversity of the African yam bean rhizobia in four Ghanaian soils. M.Phil. thesis. University of Ghana. <http://197.255.68.203/handle/123456789/7097>
- Uguru MI, Madukaife SO (2001) Studies on the variability in agronomic and nutritive characteristics of African yam bean (*Sphenostylis stenocarpa* Hochst. ex. A. Rich. Harms). *Plant Prod Res J* 6:10–19
- USDA Agricultural Research Service (2015) Germplasm Resources Information Network (GRIN). Ag Data Commons. <https://doi.org/10.15482/USDA.ADC/1212393>. Accessed 2020-11-29.
- World Bank (2014) Turn down the heat: confronting the new climate normal. World Bank, Washington, DC. License: creative commons attribution – non commercial – no derivatives 3.0 IGO (CC BY-NC-ND 3.0 IGO). <http://documents.worldbank.org/curated/en/317301468242098870/pdf/927040v20WP0000ull0Report000English.pdf>
- Yetunde EA, Ukpog SU, Olajumoke L, Ime FA (2009) Nutrient composition and sensory properties of cakes made from wheat and African yam bean flour blends. *J Food Technol* 7:115–118

**Open Access** This chapter is licensed under the terms of the Creative Commons Attribution 4.0 International License (<http://creativecommons.org/licenses/by/4.0/>), which permits use, sharing, adaptation, distribution and reproduction in any medium or format, as long as you give appropriate credit to the original author(s) and the source, provide a link to the Creative Commons license and indicate if changes were made.

The images or other third party material in this chapter are included in the chapter's Creative Commons license, unless indicated otherwise in a credit line to the material. If material is not included in the chapter's Creative Commons license and your intended use is not permitted by statutory regulation or exceeds the permitted use, you will need to obtain permission directly from the copyright holder.





# Underutilized Indigenous Vegetables' (UIVs) Business in Southwestern Nigeria: Climate Adaptation Strategies

# 26

V. A. Tanimonure

## Contents

Introduction .....	472
Methodology .....	475
The Study Area .....	475
Sample Size and Sampling Procedure .....	476
Data .....	477
Data Analysis .....	478
Results and Discussion .....	478
Farmers' Perception of Climate Change .....	478
Comparison of Responses of UIVs to Changes in Rainfall .....	483
Adaptation Strategies Adopted by the UIVs Farmers .....	484
Variable Description of Adopters and Nonadopters of UIVs Producers .....	488
Determinants of the Decision of UIVs Farmers to Adopt Climate Change Adaptation Strategies .....	489
Conclusion and Recommendations .....	489
References .....	491

## Abstract

The impact of climate change, especially on agricultural sector, calls for a global and more localized strategies such as cultivation of underutilized indigenous vegetables (UIVs) which adapt better to local climate change. This chapter, therefore, examines the perception of UIVs farmers to climate change, their experiences of UIVs' responses to climate change, adaptation strategies

---

V. A. Tanimonure (✉)  
Agricultural Economics Department, Obafemi Awolowo University, Ile-Ife, Nigeria  
e-mail: [tanimonurevic@oauife.edu.ng](mailto:tanimonurevic@oauife.edu.ng)



employed, and the determinants of the decision to adopt them in Southwest Nigeria. The study uses quantitative and qualitative primary household data from 191 UIVs farmers, 8 Focus Group Discussions (FGDs), and secondary climate data from the Nigerian Meteorological Agency. Descriptive and econometric analyses are employed in the data analyses. The results show that farmers' perceptions of climate change are high temperature and a high variability in rainfall pattern that has affected the yield, increased insects, pests, and diseases infestations, and reduced soil fertility. The results further show that the responses of UIVs to these resultant effects differ as such, and adaptation strategies farmers adopt are UIVs-specific. The adaptation strategies mostly employed by the UIVs farmers are cultivating UIVs along the river bank and the least is agroforestry and perennial plantation. The determinants of the decision to adopt adaptation strategies include UIVs revenue, age, years of experience, access to climate information, climate change awareness, agro ecological zone, and access to credit. Thus, promotion of UIVs business is advocated and provision of information on climate change essential and will encourage farmers to adopt appropriate climate change adaptation strategies to boost UIVs business.

---

**Keywords**

Climate change · Adaptation strategies · Underutilized · Indigenous vegetables · Nigeria

---

**Introduction**

The impact of climate change forecast on agriculture has posed a threat to the sustainability of global food security and nutrition. For instance, over half a billion (525 million) people in the tropics were projected by Consortium of International Agriculture Research (CGIAR) program on Climate Change Agriculture and Food Security (CCAFS) to possibly be at the perils of hunger by 2050 due to climate change (Actionaid International 2011). Intergovernmental Panel on Climate Change (IPCC) (2014) also predicted climate change increasing current problems and also generating new ones for natural and human systems. Likewise, Boko et al. (2007) predicted that reductions in yield of up to 50% in some countries in Africa by 2020 and net crop revenue by as much as 90% by 2100 could be attributed to climate change, smallholder farmers being mostly affected, especially the rural farmers who depend largely on rain-fed agriculture (Ching and Stabinsky 2011). Until adaptive or palliative measures are inaugurated to mollify the effects of climate change, food security in developing countries in the tropics, particularly in Nigeria, will be under threat (Enete 2014), considering the high rate of population growth.

Owing to the undesirable effects of climate change, it is suggested that a blend of global and more localized strategies, along with other adaptation strategies, can help farmers weather the effects of climate change. These include conservation agriculture, organic agriculture, carbon sequestration and the capacity to withstand weather stresses, change in planting time, the breeding of a number of climate-resilient crop varieties such as underutilized indigenous vegetables (UIVs), among others (Howden et al. 2007; Omatseye 2009; Sambo 2014). Underutilized indigenous vegetables are vegetables that originate from a locality; such vegetables may be localized to that particular area or found in other places. They are reported to be grown more widely or intensively in the past but are falling into disuse for a number of agronomic, genetic, economic, and cultural reasons. They are promising species but their potentials in terms of economic, nutrition, medicinal, and resilience have not been fully harnessed. Farmers, marketers and consumers are not making the best use of these crops as much as they use others because they are less competitive compared with other crops in the same agricultural environment (Guarino 1997; Eyzaguirre et al. 1999; IPGRI 2002; Padulosi and Hoeschle-Zeledon 2004). More so, these vegetables have not been a subject of organized research until recently (Tanton and Haq 2008). For instance, in the recent times, the production, marketing, and consumption of some of these vegetables are promoted in Southwest Nigeria in projects tagged NiCanVeg and MicroVeg. Some studies also reported that these UIVs are more adaptive, resilient, and tolerant to adverse climatic conditions than exotic species (Raghuvanshi and Singh 2001; Nnamani et al. 2009; Mabhaudhi et al. 2016).

In comparison to other crops, vegetables generally are more susceptible to environmental extremities such as high temperatures and soil moisture stress. Carbon dioxide, a major greenhouse gas, influences their growth and development as well as incidence of insect pests and diseases that render vegetable production unprofitable (Devi et al. 2017; Abewoy 2018). And all these will increase in the face of climate change (Ayyogari et al. 2014). However, UIVs can be produced comparatively at lower management cost, on marginal soil, and can tolerate the dynamics of climate change better than the exotic vegetables (Raghuvanshi and Singh 2001; Nnamani et al. 2009; Padulosi et al. 2011). This offers a significant opportunity for poor people in the rural areas to withstand the effect of climate change and increase their revenue, and, thereby, be food and nutrition secure (Maroyi 2011; Ebert 2014). This is because many UIVs from the tropics are already well adapted to the climatic conditions, and, as such, respond better to climatic conditions.

Unfortunately, there is limited quantitative and qualitative information supporting all these claims (Padulosi et al. 2011; Intergovernmental Panel on Climate Change (IPCC) 2014; Chivenge et al. 2015). The knowledge of UIVs adaptation to climate change remains concealed in the indigenous knowledge systems and this may

explain why certain communities have continued to preserve and utilize certain UIVs. The limited quantitative empirical information indicates that UIVs remain under-researched as well. Although, some studies identified the potentials of these neglected and underutilized crops in sub-Saharan Africa in the recent times. A research by Adebooye and Opabode (2004), for example, was particular about the conservation of these indigenous crops in order to prevent them from going into extinction, especially as the reliance on a handful of major crops has innate agronomic, nutritional, and economic risks, which is not sustainable in the long run (Ebert 2014). Ayanwale et al. (2011) and Aju et al. (2013) also studied the market potentials of some of these underutilized indigenous vegetables and envisaged good commercial prospect in them, especially for women folks who are resource constrained. Some of the representatives of these leafy vegetables, tuber crops, cereals, and grain legumes that fit into the class of underutilized crops were identified by Maroyi (2011), Shrestha (2013), and Chivenge et al. (2015). It was equally found out that they are potential future crops for smallholder farmers, as sources of nutrition and income, especially in this era of climate change. Study by Sambo (2014) showed that underutilized crops could offer scientists a rich source of genetic materials for modification, which could hold potential key to developing resilient and drought-tolerant crops. Recent research found out that these underutilized indigenous crops have the ability to grow under water-scarce conditions and that the key to future food and nutrition security may lie in their untapped potentials (Mabhaudhi et al. 2016). More recent research shows qualitatively that climate change has both positive and negative effects on indigenous vegetables and the predicted negative effect cannot be overemphasized (Chepkoech et al. 2018). Indigenous vegetables farmers, therefore, adopt a number of adaptation strategies to mitigate the effect of climate change on their production activities. Although Fadaïro et al. (2019) examined the perceived likelihood impact and adaptation of vegetables farmers to climate change, their emphasis was not on indigenous vegetables which is the focus of this study. Their study advocated for locality-specific climate change adaptation strategies.

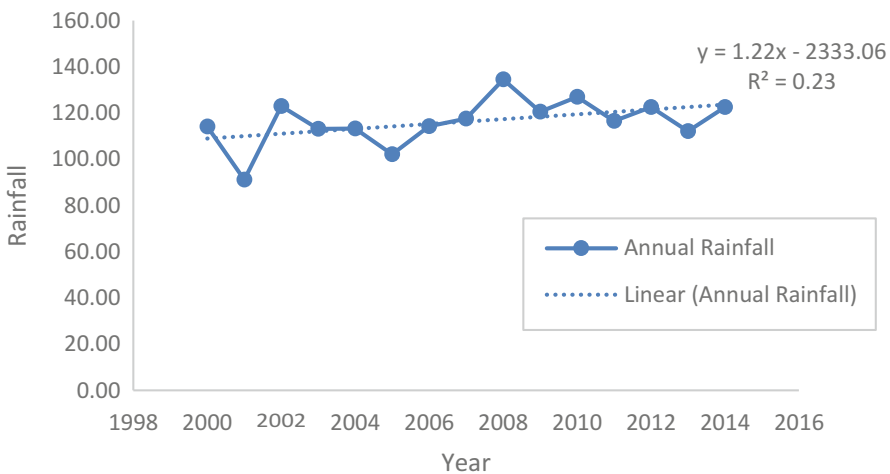
The Intergovernmental Panel on *Climate Change* (IPPC) defines *adaptation* as “any adjustment in natural or human systems in response to actual or expected *climatic* stimuli or their effects which moderates harm or exploits beneficial opportunities.” Climate adaptation is termed as a correct adjustment to climate variability and change, especially for smallholder farmers to enhance resilience or reduce vulnerability to its effects (Fadaïro et al. 2019).

This study, therefore, aims to examine the perception of UIVs’ farmers and the responses of UIVs to climate variability and change in the study area. It assesses the adaptation strategies adopted by the farmers to cope with the adverse effects of climate change and lastly, analyzes the determinants of the decision to adopt adaptation strategies by the UIVs farmers. This will add to the existing literature on the resilience of underutilized indigenous vegetables to climate variability and change in sub-Saharan Africa.

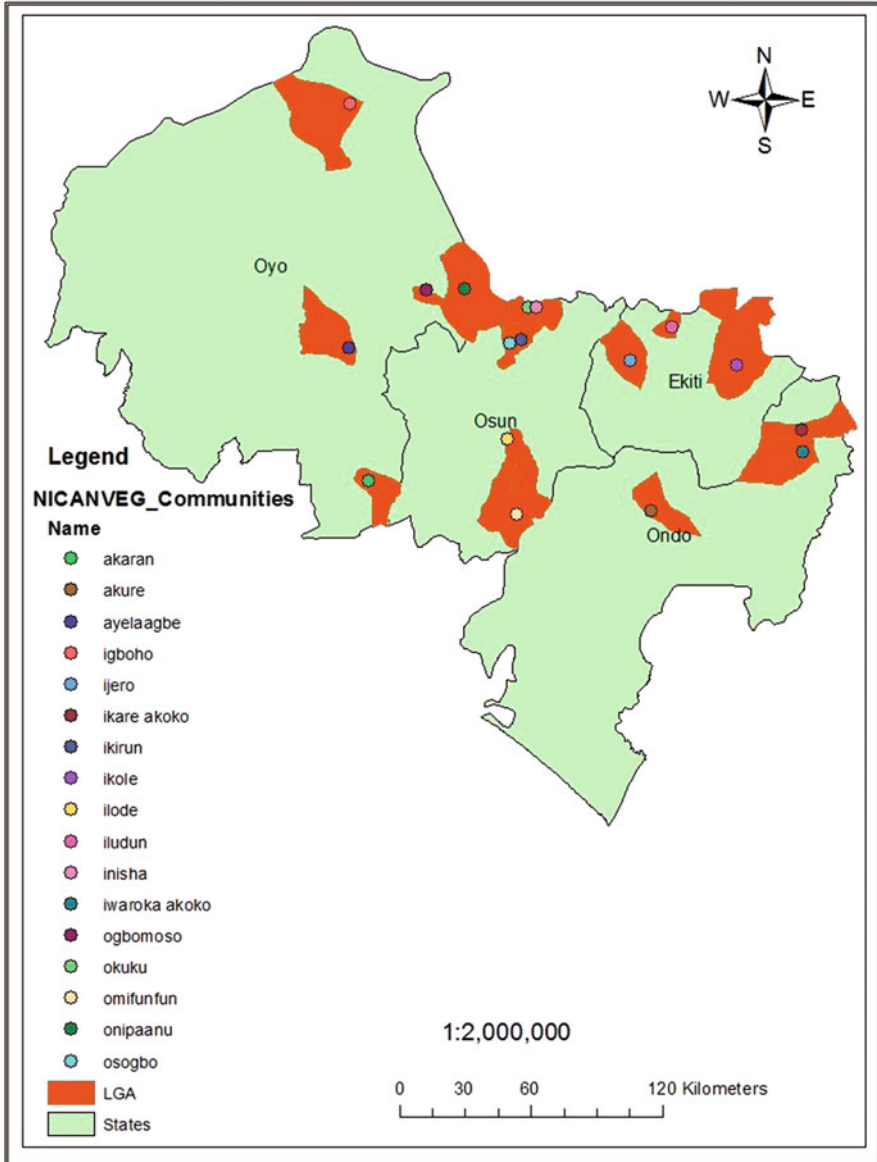
## Methodology

### The Study Area

The study area is South west region of Nigeria as presented in Fig. 1. The area lies between longitude  $2^{\circ} 31'$  and  $6^{\circ} 00'$  east and latitude  $6^{\circ} 21'$  and  $8^{\circ} 37'$  norths. The study area is bounded in the east by Edo and Delta States, in the north by Kwara and Kogi States, in the west by the Republic of Benin, and in the south by the Gulf of Guinea. The region constitutes about one sixth ( $\sim 163,000 \text{ km}^2$ ) of the total land area of Nigeria and comprises six states (Oyo, Ogun, Osun, Ondo, Ekiti, and Lagos) and is distinctly divided into three major agro-ecological zones (Rain Forest zone, Swamp Forest zone, and Derived Savannah zone) with diverse climatic conditions. The forest agro-ecological zone has annual rainfall in the range of 1,600–2,400 mm, with cropping seasons between April and November, while dry spells occur from December to March. The soil types in this zone depend largely on parent rock; where the underlying rocks are granite or clay, the soil is a rich clayey loam. On the other hand, the derived savannah agro-ecological zone has mean annual rainfall ranging from 800 to 1,500 mm, with cropping seasons between June and November. The soil types range from the sandy to clayey in texture, with soil reaction ranging from acidic to slightly basic. Soil fertility statuses and crop species diversity also vary widely in different locations in the region. This study is carried out in two of the three agro-ecological zones: Rain Forest and Derived Savannah zones, where UIVs were promoted in a project tagged NiCanVeg.



**Fig. 1** Annual rainfall trend in Southwest Nigeria



### Sample Size and Sampling Procedure

All the 17 NiCanVeg communities in 16 Local Government Areas (LGAs) of the four (Ekiti, Ondo, Osun, and Oyo) states were selected for this research. In order to ensure representativeness and due to limited budget, a simplified formula (Eq. 1)

developed by Kothari (2004) was used to calculate the sample size of the respondents at the community level. A 95% confidence level, 5% estimated percentage, and  $P = 0.5$  were assumed in the equations.

$$n = \frac{Z^2 X p X q X N}{e^2 X (N - 1) + Z^2 X p X q} \quad (1)$$

where

$n$  is the sample size

$N$  is the population size

$e$  is the estimated proportion

$p$  is sample proportion,  $q = 1 - p$

$z$  is the value of the standard variate at a given confidence level and to be worked out from Table showing area under Normal Curve.

Based on this formula, the respondents' sample size is approximately 191 (which was about 50% of the direct beneficiaries of NiCanVeg project in the study area).

In each NiCanVeg site, the NiCanVeg farmers were stratified into male and female to ensure random selection of both sexes, and 50% of the total farmers were randomly selected from NiCanVeg farmers' lists. This proportionate sampling procedure was necessary because of the difference in the number of farmers in each community or site.

## Data

The mixed-methods research design involving both the quantitative and qualitative research approaches were employed to elicit information from the respondents. The quantitative study involved face-to-face data collection with the use of structured questionnaire. The questionnaire administration was done by the trained enumerators to ensure the quality of the data. Before the data collection, there was an "advance notification" sent to the respondents to let them know that the survey would be conducted in their communities. The enumerators were led to the communities by the NiCanVeg field officer who was already familiar with the farmers and the communities. Two Focus Group Discussions (FGDs) per state were conducted among the UIVs farmers to gather the qualitative data used for the study. The data collected include UIVs' household socioeconomic characteristics, their perception of climate change, and the various adaptation strategies adopted over the years to mitigate the effects of climate change, information on various vegetables they cultivate, the reasons why they cultivate the vegetables, and the responses of the vegetables to the perceived negative effects of climate variability in the study area. The FGDs with the farmers generated information on the type of vegetables cultivated across the four states, their order of economic importance, and the responses of these vegetables to resultant or indirect effects of climate change

variables (rainfall and temperature) such as drought, flood, insect infestations, pests, and diseases. Farmers were asked to describe climate change variables expressed as changes in amount of rainfall and temperature on the extent of drought, changes in insect infestations, soil fertility, and UIVs yield. Also, UIVs producers' perceptions of climate change are compared with historical trends from Nigerian Meteorological data (average monthly temperature and rainfall) between 2000 and 2014.

## Data Analysis

Both descriptive statistics and econometric analyses are used in the data analysis. Descriptive statistics such as frequency counts, means, and percentages are employed to describe the socio-economic characteristics of the respondents and the effects of climate change adaptation strategies on UIVs production. Content analysis was employed for the qualitative data collected through the FGDs. For the econometric analysis, logistic regression inferential statistic was used to analyze the factors affecting UIVs farmers' decisions to adopt adaptation strategy or not (Mahouna et al. 2018). In this study, the dependent variable is dichotomous, that is, farmers' decision to either adopt or not adopt climate change adaptation strategy. This method is appropriate because it considers the relationship between a binary dependent variable and a set of independent variables.

---

## Results and Discussion

Table 1 summarizes the distribution of the UIVs that farmers cultivate in order of economic importance across the four States that the study covered. The summary reveals while good number of the UIVs are found across the entire region, only few UIVs are state specific. For instance, it is only in Osun State that red amaranth is produced in commercial quantity. Also, it is only in Oyo State (northern part) that *Solanum zaccagnianum* (locally called osun) is cultivated in commercial quantity. Aside Ondo State where ugu is the most economically important UIV, amaranth species remain the most economically viable UIV in the region. It is also noteworthy that respondents in Oyo State ranked two different UIVs as first economic important vegetables. While the UIVs producers in the northern part of the State ranked *Solanum zaccagnianum* as number one economically important UIV, those in the southern part ranked amaranth species as the number one in term of economic importance.

## Farmers' Perception of Climate Change

Perception is the way something is regarded, understood, or interpreted. It is one of the first important steps in the process of designing some form of change in farmers' livelihood system to adapt to the changing climate. In order to get essential information and insight into farmers' perception of climate change, the two most important

**Table 1** Distribution of UIVs production in the study area

Local name	English name	Scientific name	Order of economic importance
<b>Osun State</b>			
Tete Abalaye	White amaranth	<i>Amaranth viridis</i>	1
Red Tete/Tete Ijesa	Red amaranth	<i>Amaranth cruentus</i>	2
Ewedu	Jute mallow	<i>Corchorus olitorius</i>	3
Ugu	Fluted pumpkin	<i>Telfairia occidentalis</i>	4
Igbagba/Gboma	African eggplant	<i>Solanum macrocarpon</i>	5
Worowo	Bologi	<i>Solanecio biafrae</i>	6
Soko	Quail grass	<i>Celosia argentea</i>	7
Waterleaf	Waterleaf	<i>Talinum fruticosum</i>	8
Ebolo	Fire weed	<i>Crassocephalum crepidoides</i>	9
Elegede	Field pumpkin	<i>Cucurbita moschata</i>	10
Ogunmo	Garden huckleberry	<i>Solanum scabrum</i>	11
<b>Oyo State</b>			
Osun	–	<i>Solanum zaccagnianum</i>	1
Tete Abalaye	White amaranth	<i>Amaranth viridis</i>	1
Ogunmo	Garden huckleberry	<i>Solanum scabrum</i>	2
Ewedu	Jute mallow	<i>Corchorus olitorius</i>	3
Igbagba/Gboma	African eggplant	<i>Solanum macrocarpon</i>	4
Soko	Quail grass	<i>Celosia argentea</i>	5
Ugu	Fluted pumpkin	<i>Telfairia occidentalis</i>	6
Odu	Black nightshade	<i>Solanum nigrum</i>	7
Ebolo	Fire weed	<i>Crassocephalum crepidoides</i>	8
<b>Ondo State</b>			
Ugu	Fluted pumpkin	<i>Telfairia occidentalis</i>	1
Igbagba/Gboma	African eggplant	<i>Solanum macrocarpon</i>	2
Tete Abalaye	White amaranth	<i>Amaranth viridis</i>	3
Soko	Quail grass	<i>Celosia argentea</i>	4
Elegede	Field pumpkin	<i>Cucurbita moschata</i>	5
Ogunmo	Garden huckleberry	<i>Solanum scabrum</i>	6
Worowo	Bologi	<i>Solanecio biafrae</i>	7
Odu	Glossy nightshade	<i>Solanum nigrum</i>	8
<b>Ekiti State</b>			
Abalaye	White amaranth	<i>Amaranth viridis</i>	1
Igbagba/Gboma	African eggplant	<i>Solanum macrocarpon</i>	2
Ugu	Fluted pumpkin	<i>Telfairia occidentalis</i>	3
Ewedu	Quail grass	<i>Celosia argentea</i>	4

(continued)



**Table 1** (continued)

Local name	English name	Scientific name	Order of economic importance
Waterleaf	Fire weed	<i>Crassocephalum crepidoides</i>	5
Odu	Field pumpkin	<i>Cucurbita moschata</i>	6
Soko	Quail grass	<i>Celosia argentea</i>	7
Worowo	Bologi	<i>Solanecio biafrae</i>	8
Ogunmo	Garden huckleberry	<i>Solanum scabrum</i>	9

Source: Field survey, 2016

**Table 2** Farmers' perception on rainfall and temperature change

Farmers' perception	Rainfall	Temperature
No change	10 (5.24)	10 (5.24)
Yes, increasing	8(4.19)	161(84.29)
Yes, decreasing	134(70.16)	14(7.33)
Erratic	38(19.90)	0
Indifference	1(0.52)	6(3.14)

Source: Field survey, 2016

elements of climate rainfall and temperature are considered in this study. Out of the 191 sample respondents, only 10 (5.24%) are of the opinion that there is no change in the climate as presented in Table 2. This result shows that farmers are well aware of climate change. This result is similar to Fadairo et al. (2019), who also found that awareness of climate variability and change was high among vegetables farmers.

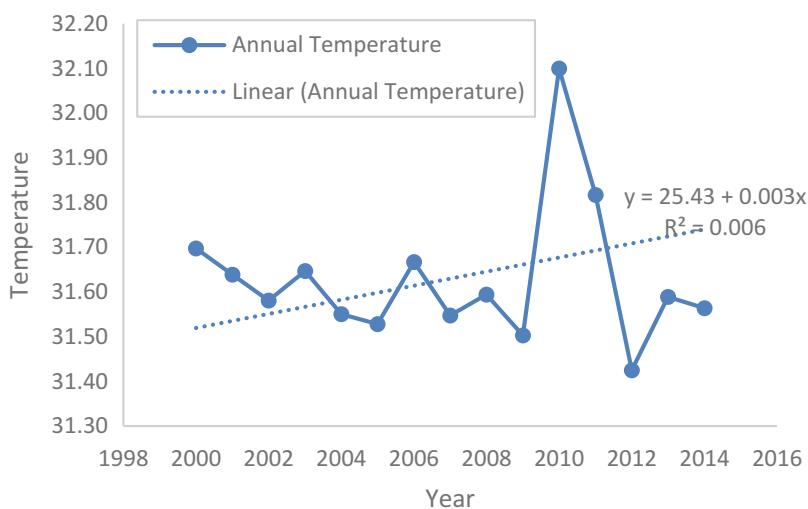
### Farmers' Perception of Change in Rainfall Versus Meteorological Data

The perception of UIVs farmers in the study area on the overall trend of average rainfall as presented in Table 2 shows that all the respondents who are aware of climate change perceived changes in the rainfall, although their perception of these changes differs. About 74% of the respondents perceived decrease in average rainfall; about 4% perceived increase in rainfall, while about 21% could not say categorically whether the rainfall increased or decreased, but noticed an erratic rainfall over the years. Only 1% are indifferent to the rainfall pattern. The trend analysis of rainfall from Meteorological data between 2000 and 2014 in the area under study is presented in Fig. 1. The trend shows that there is no particular trend in average annual rainfall, as the rainfall pattern has been erratic. In year 2000, the average annual rainfall is high and falls in 2001. In 2002, the rainfall increases, falls in 2003, remains a little steady in 2004, and falls in 2005. The highest average rainfall within the period under study is in 2008 and since then, the average annual rainfall keeps rising and falling, although the quantitative trend shows that there is increase in average annual rainfall amount in the study area. The result of regression analysis between rainfall and time shows that an increase in one-year period results

in a corresponding increase in the amount of average annual rainfall by 1.22 mm (Fig. 1). However, the perception of most farmers of rainfall shows a view contrary to the information contained in the meteorological recorded data. The majority of UIVs producers perceived reduction in rainfall. This lack of congruence could be as a result of the farmers assessing rainfall in relation to the needs of UIVs at a particular time; small change in quantity, onset, and cessation of rain over days make a big difference in the hearts of farmers, whereas the Meteorological data is more likely to measure total and large effects (Lemmi 2013).

### Farmers' Perception of Change in Temperature Versus Meteorological Data

In the case of average temperature, all the UIVs farmers who are aware of climate change perceived changes in average temperature over the years (Table 2). Majority (88.95%) of UIVs producers perceived increase in average annual temperature in the study area. Only 8% perceived decrease in the temperature, while the remaining percentage of respondents (3.31%) are indifferent to the changes in temperature. The trend analysis of the meteorological data of temperature between 2000 and 2014 shows an increasing trend. The regression between average annual temperature and time shows that an increase in one-year period results in an increase in the average temperature of the area by 0.003 °C (Fig. 2). Thus, farmers' perception appears to be in consonant with the statistical record of temperature from the meteorological station. This result is also in line with (Chepkoech et al. 2018), who also found increasing trend in the temperature of study area.



**Fig. 2** Annual temperature trend in Southwest Nigeria

### Farmers' Perception of Resultant Effects of Climate Change Variables

The outcome of changes in average annual rainfall and temperature results into different anomalies such as drought frequency, insects, pests and diseases infestations, loss of soil fertility, reduction in yield, among others (Chepkoech et al. 2018). Table 3 presents the perception of UIVs farmers to some of these anomalies brought about by climate change in the study area in relation to UIVs production. About 88%

**Table 3** UIVs farmers' perception of resultant effects of climate change variables

UIVs farmers' perceived effects of climate change	Frequency	Percentage
<b>Change in drought</b>		
No change	0	0.00
Yes, increasing	161	88.29
Yes, decreasing	14	7.33
Indifference	6	3.14
No response	10	5.24
<b>Change in pests and insects infestation</b>		
No change	0	0.00
Yes, increasing	145	75.92
Yes, decreasing	16	8.38
Indifference	11	5.76
No response	19	9.95
<b>Change in Soil fertility</b>		
No change	0	0.00
Yes, increasing	28	14.66
Yes, decreasing	122	63.87
Indifference	31	16.23
No response	10	5.24
<b>Change in UIVs Yield</b>		
No change	0	0.00
Yes, increasing	36	18.85
Yes, decreasing	141	73.82
Indifference	4	2.09
No response	10	5.24
<b>Change in annual Earnings</b>		
No change	0	0.00
Yes, increasing	36	18.85
Yes, decreasing	139	72.77
Indifference	5	2.62
No response	11	5.76
<b>Changes in the Land area allotted to UIVs</b>		
No change	0	0.00
Yes, increasing	129	67.54
Yes, decreasing	50	26.18
Indifference	1	0.52
No response	11	5.76

Source: Field survey, 2016

of the UIVs producers believe that occurrence of drought has increased over the years as a result of reduction and/or erratic pattern of rainfall. The excerpts of the farmers during the FGDs further establish the negative effects of drought on the production activities of UIVs:

The erratic rainfall has brought problem to farmers because most of what we plant did not germinate on time and some even got burnt in the soil as a result of prolonged drought  
FGD with Farmers in Ilesha, Osun State.

About 76% of the respondents indicated that the effect of insect infestation has increased greatly in recent times, compared to the past. The excerpts from the FGDs affirm this:

There is reduction in our output due to climate change; there are some insects destroying our farm produce. To the extent that we have to take some of the species of the insect to laboratory for the scientist to help us find solution to it because the insecticide we have been using are no longer effective

FGD with farmers in Ilesha, Osun State.

... also what we have experienced this year has never been experienced before. That we plant all vegetables and insect and pest spoil some specific vegetables. Pest also spoilt all the maize and some other crops.

FGD with farmers in Ile-Ife, Osun State.

There is no positive impact. Our expectation has been dashed because there is irregularity in rainfall. Our profits are low, insects infested our farm and destroyed it

FGD with farmers in Iwaroka, Ekiti State.

Also, the response of UIVs farmers to the effect of climate change on soil fertility is negative. About 64% of the farmers are of the opinion that soil fertility has decreased greatly. More so, most (73.82%) UIVs farmers experienced reduction in yield and, as a result of this, about 73% testified to the fact that this, invariably, has drastically reduced their earnings from UIVs production. Excerpts from the FGDs conducted buttress these facts thus:

Since there is irregularity in rainfall, we don't really get the normal output, so it has reduced our income

FGD with farmers in Igbobo, Oyo State.

Although, there is good market for vegetables now, but the insect infestation has reduced our output which resulted in low income, and this had brought financial difficulties on farmers

FGD with farmers in Ilesha, Osun State.

## **Comparison of Responses of UIVs to Changes in Rainfall**

An understanding of the responses of UIVs to the indirect effect of climate change variables such as yield reduction, insect, pests, and diseases infestations is very crucial. This will guide farmers on the type of climate change adaptation strategies to

adopt in order to reduce the negative impact of climate change on UIVs production. The responses of the farmers across the four States are harmonized and summarized in Table 4. Unanimously, the farmers across the four States agreed that the UIVs' response to resultant effects of climate change differs and it is premised on the type of UIVs and season. This finding is in an agreement with Chepkoech et al. (2018) who also found that the sensitivity of African Indigenous Vegetables to climate change variables is determined by the season and the type of vegetable, for instance, in the case of amaranth species, fluted pumpkin, jute mallow, and African eggplant; extreme rainfall does not really have effect on both their yield and the incident of insects and pests' infestations, although they experience moderate disease infestation such as yellowing of leaves. During the dry season, their yields are moderately low and moderate rate of pests and insects' infestation occur. The disease infestations are rare during this period for the vegetables.

During the high rainfall and low rainfall periods, osun, glossy nightshade, garden huckleberry, and quail grass are moderately affected in terms of yield, pests, insects, and disease infestations. In the case of field pumpkin and fire weed, there is moderate reduction in yield and disease infestation but not affected by pests and insects during the excessive rainfall period. Extremely low rainfall or dry spell reduced the yield moderately and the effect of insects and pests too is moderate and there is no disease infestation for field pumpkin. But for fire weed, the dry spell reduced the yield greatly; in fact, the fire weed may be totally unavailable in the market. While the yield of Bologi is moderately reduced by excessive rainfall, that of waterleaf is not affected. The two UIVs are not affected by insects and pests and diseases infestation during the extreme high and low rainfall but their yields are greatly reduced during the low rainfall. It is noteworthy that lots of nutrients are washed and leached away during the excessive rain fall period. From the result, it is obvious that excessive rainfall encourages diseases infestation while low rainfall or dry spell encourages insects and pests' infestation. The result is in harmony with Chepkoech et al. (2018) results. The ranking of the UIVs that are cultivated by the farmers in the study area in order of drought tolerance is also presented in Table 4; ugu is the most drought tolerant while Bologi is ranked last on the list.

### **Adaptation Strategies Adopted by the UIVs Farmers**

A number of adaptation strategies are adopted by the UIVs farmers in order to weather the negative effects of climate change (Fadairo et al. 2019) presented in Table 4. The adaptation strategies adopted by the UIVs farmers are presented in Table 5. From the Table, only about 15% of the farmers do not adopt any strategy. This result is similar to Mahouna et al. (2018), who also identified only 14.2% of the sample respondent as nonadopter of climate change adaptation strategy but at variance with Fadairo et al. (2019) who found that all vegetable farmers adopted one form of adaptation strategy or the other. From the discussion with the farmers, it was gathered that the most important adaptation strategies adopted by UIVs farmers

**Table 4** Comparison of responses of UIVs to resultant effects of changes in rainfall

UIVs	Response of UIVs to very high rainfall				Response of UIVs to very low rainfall				Order of drought tolerance
	Yield	Insects and pests infestation	Diseases infestation	Soil fertility	Yield	Insects and pests infestation	Diseases infestation	Soil fertility	
White amaranth	No change in yield	Not affected	Moderate infestation	Leached Nutrient	Moderate reduction in yield	Moderate infestation	Not affected	Moderate effect	5
Red amaranth	No change in yield	Not affected	Moderate infestation	Leached Nutrient	Moderate reduction in yield	Moderate infestation	Not affected	Moderate effect	5
Fluted pumpkin	No change in yield	Not affected	Moderate infestation	Leached Nutrient	Moderate reduction, tough leaves	Moderate infestation	Not affected	Moderate effect	1
Field pumpkin	Moderate reduction in yield	Not affected	Moderate infestation	Leached Nutrient	Moderate reduction in yield	Moderate infestation	Not affected	Moderate effect	4
Jute mallow	No change in yield	Not affected	Moderate infestation	Leached Nutrient	Moderate reduction, tough leaves	Moderate infestation	Not affected	Moderate effect	3
African eggplant	No change in yield	Not affected	Moderate infestation	Leached Nutrient	Moderate reduction in yield	Moderate infestation	Not affected	Moderate effect	2
Osun	Moderate reduction in yield	Moderate infestation of pests	Moderate infestation	Leached Nutrient	Moderate reduction in yield	Moderate infestation	Moderate infestation	Moderate effect	4

(continued)

Table 4 (continued)

UIVs	Response of UIVs to very high rainfall				Response of UIVs to very low rainfall				Order of drought tolerance
	Yield	Insects and pests infestation	Diseases infestation	Soil fertility	Yield	Insects and pests infestation	Diseases infestation	Soil fertility	
Glossy nighthshade	Moderate reduction in yield	Moderate infestation of pests	Moderate infestation	Leached Nutrient	Moderate reduction in yield	Moderate infestation	Moderate infestation	Moderate effect	4
Garden huckleberry	Moderate reduction in yield	Moderate infestation of pests	Moderate infestation	Leached Nutrient	Moderate reduction in yield	Moderate infestation	Moderate effect	Moderate effect	4
Quail grass	Moderate reduction in yield	Moderate infestation of pests	Moderate infestation	Leached Nutrient	Moderate reduction in yield	Moderate infestation	Moderate effect	Moderate effect	6
Fire weed	Moderate reduction in yield	Not affected	Moderate infestation	Leached Nutrient	High reduction in yield	-	-	-	7
Bologi	Moderate reduction in yield	Not affected	No infestation	Leached Nutrient	High reduction in yield	No infestation	Moderate effect	Moderate effect	9
Waterleaf	Not affected	Not affected	No infestation	Leached Nutrient	High reduction in yield	No infestation	Moderate effect	Moderate effect	8

**Table 5** Adaptation strategies adopted by the UIVs farmers

Adaptation strategy	Frequency	Percentage	Position
No adaptation	29	15.18	8th
Crop diversification	51	26.70	3rd
Changing time of planting	45	23.56	4th
Diversification to other nonagricultural activities	121	63.35	2nd
Agroforestry and perennial plantation	7	3.66	9th
Use of integrated pest management and use of fertilizer	39	20.42	7th
Cultivating along river banks	187	97.91	1st
Good practices (mixed cropping, crop rotation, mulching, organic fertilizer)	44	23.04	5th
Irrigation	41	21.47	6th

over the years is to cultivate UIVs along the river bank during the dry season and use upland during the wet season to reduce the incident of diseases and flood from excessive high rainfall. About 98% adopt this strategy. The information gathered further reveals that about 63% of UIVs producers are diversifying from agriculture to nonagricultural related businesses as a result of their unpalatable experiences in farming. Some of the excerpts from the FGDs show that many farmers are discouraged as a result of some of their experiences. The third popular adaptation strategy option is crop diversification. About 27% of the respondents indicated crop diversification as adaptation strategy they have adopted. An excerpt from the FGD in Ile-Ife, Osun State, shows this:

... that was why I changed to okra plantation. When I tried it and it performed better, I decided to change to okra cultivation

FGD with farmers in Ile-Ife, Osun State

Also, 23.56% changed time of planting, and about 23% also adopted agricultural good practices such as mulching, crop rotation, and mixed cropping. About 21% adopted irrigation, but the excerpts from the FGD show that where rain failed, some adopted irrigation system and it led to outbreak of insect infestations which pesticide could not handle. The excerpt from the FGD in Osun State reveals this thus:

The first step we took when the rain did not fall was to use irrigation. Different pests and insect infestations showed up. We used different insecticides to kill the insects, but chemical compositions were no longer effective like before.

FGD with farmers in Ilesha, Osun State

It was noteworthy that the least (3.66%) adaptation strategy adopted by the UIVs farmers is agroforestry and perennial plantation, and about 15% do not adopt any adaptation strategy.



## Variable Description of Adopters and Nonadopters of UIVs Producers

The description of the socioeconomic characteristics of UIVs farmers and other relevant variables to this study are summarized in Table 6. The information provided in the table shows that the nonadopters are significantly older than the adopters. There is no significant difference between their years of formal education, UIVs vegetable land area, access to climate change information, agro-ecological zone, and average monthly temperature of adopters and nonadopters in the study area. Meanwhile, the adopters had significantly higher mean values of the years of UIVs production experience, net revenue from UIVs, off-farm income, average monthly precipitation, farm distances from market and main road than the nonadopters.

**Table 6** Variables and summary statistics

Variable	Nonadopters		Adopters		Mean difference
	Mean	SD	Mean	SD	
Age of respondent	45.28	13.65	42.18	14.16	3.10***
Years of formal education	9.07	4.80	9.23	4.68	-0.17
Years of UIVs production experience	10.79	7.24	12.79	9.61	-2.00***
UIVs Land area	0.11	0.18	0.22	0.49	-0.12
Access to climate information (1/0)	0.48	0.51	0.73	0.45	-0.25
Agro ecological zone	0.69	0.47	0.85	0.36	-0.16
Net revenue	9,420,215	14,100,000	16,700,000	27,020,000	-7,276,625***
Off farm income	5,47,848.30	5,80,313.8	1,043,479	2,109,412	-4,95,630.40***
Average monthly temperature	31.44	2.33	31.66	2.36	-0.22
Average monthly precipitation	114.95	91.98	116.54	82.39	-1.59***
Farm distance from market	5.60	4.02	6.12	4.57	-0.52***
Farm distance from main road	1.70	1.58	2.21	3.41	-0.53***

\*\*\* = Significant at 1% level

## **Determinants of the Decision of UIVs Farmers to Adopt Climate Change Adaptation Strategies**

Binary logistic regression analysis was used to analyze the determinants of the decision to adopt climate change adaptation strategies by the UIVs farmers in the study area. Variables such as revenue from UIVs, age, sex, household size, education, marital status of the respondents, vegetable farm size, farm distance to market and main road, experience in vegetable farming, access to climate information, climate change awareness, and agroecological zone are included in the analysis. The results of the analysis reveal that the revenue generated from the UIVs business has a positive and significant influence at the 1% threshold on the adoption of climate change adaptation strategy. The more the revenue generated from the business, the more likely the producer will be willing to adopt adaptation strategy. This implies that adoption of adaptation strategy is not free and resources for the implementation must be available for farmers to adopt. The age of UIVs producers is significant at 10% level but negative. The implication of this is that as farmers increase in age the likelihood of adopting adaptation strategy reduces. This finding is in line with Uddin et al. (2014), that as farmers age, they lose interest in adopting climate change adaptation strategy. The number of years of experience in UIVs farming has positive and significant relation at 10% threshold on the adoption of adaptation strategy. This is expected, and more experience implies more competence in weather forecasting. This outcome is similar to the result of Mahouna et al. (2018) who also found that the more the experience of farmers the more the likelihood of adopting climate change adaptation strategies. Access to climate information is also significant and has positive influence at the 5% threshold on adoption of adaptation strategy. This implies that the more access farmers have to sources of information on climate change, the more likely they will adopt adaptation strategy to ease the negative effect of climate change on their business. More so, awareness of climate change is significant at 1% level and has positive effect on the likelihood of farmers to adopt adaptation strategy. This means that when farmers are aware and well informed about climate, the likelihood to adopt adaptation strategy will not be difficult. Agro ecological zone too is significant and positively determines the likelihood of farmers adopting adaptation strategy. This suggests that the effect of climate change in various agro ecological zones differ and as such, the need for climate change adaptation strategy may also differ. Lastly, access to loan is significant at 10% level and positively relates to choice of adopting adaptation strategy. Those farmers who have access to loan will likely adopt adaptation strategy since the strategies are not free (Table 7).

---

## **Conclusion and Recommendations**

This chapter presents a microlevel study on the perceived effect of climate change and adaptation strategy employed on UIVs business in Southwest Nigeria. To this end, data set from plot level survey of 191 UIVs farm was used in the analysis. UIVs

**Table 7** Determinants of the decision of UIVs farmers to adopt adaptation strategy

Adoption	Odds ratio	Standard error	z-value
Revenue	38.9202	55.3609	2.57***
Age of respondents	-0.9555	0.065	-1.64*
Sex of respondent	1.9052	1.2175	1.01
Household size	0.9895	0.0559	-0.19
Years of formal education	0.9603	0.0656	-0.59
Marital status	2.0791	2.3835	0.64
Experience in UIVs production	1.0680	0.0416	1.69*
Access to climate information	3.5169	1.9898	2.22**
Vegetable land area	3.3851	6.0988	0.68
Climate change awareness	46.7125	39.6536	4.53***
Agro ecological zone	3.0296	1.8863	1.78*
Farm distance to main road	1.0304	0.1398	0.22
Farm distance to market	0.9825	0.0710	-0.24
Membership of association	0.9301	0.5787	-0.12
Access to loan	4.4184	3.9790	1.65*
Constant	-9.97e-11	8.30e-10	-2.77***
Logistic regression	Number of observation = 191 Wald chi2 (15) = 63.84 Prob>chi2 = 0.0000 Pseudo R2 = 0.4018 Log likelihood = -47.5208		

\*, \*\*, \*\*\* = Significant at 10%, 5%, 1% level, respectively

production activities, adaptation strategies information, and meteorological data were also obtained. In conclusion, 13 economically viable UIVs are identified across the study area and their responses to the indirect climate change effect such as insects, pests, and diseases infestation, soil fertility, drought and yield, differ. While some UIVs are not affected by these climate change effects, some are moderately affected and to some others, the effect was great. The study also concludes that the occurrence of insects and pests' infestations is common whenever rain cease to fall for a long time while diseases infestation is common during the excessive rainfall in the study area during the raining season. The study further concludes that UIVs farmers adopt nine different adaptation strategies to ameliorate the effect of climate change variables on the UIVs business. The most prominent of them is the cultivating UIVs along river banks and the least practiced is agroforestry and perennial plantation.

Finally, the study concludes that the factors that determine the likelihood of farmers to adopt climate change adaptation strategy are revenue from UIVs, age of UIVs farmer, years of experience in UIVs production, access to climate information, climate change awareness, agro ecological zone, and access to credit. From the conclusion, the following recommendations are made:

- In the era of climate change, where many crops are failing, promotion of production, marketing, and consumption of UIVs is advocated for.
- Development of improved varieties of UIVs that are more tolerant to increased rainfall is needed.
- Information on climate change should be made available and accessible to farmers.
- Farmers should be trained on the right adaptation strategy to adopt, considering the type of crop they cultivate and the peculiarity of their agro-ecological zone.

**Acknowledgments** This work was supported by the UK Department for International Development under the Climate Impact Research Capacity and Leadership Enhancement (CIRCLE) Visiting Fellowship programme. Neither the findings nor the views expressed, however, necessarily reflect the policies of the UK Government.

---

## References

- Abewoy D (2018) Review on impacts of climate change on vegetable production and its management practices. *Adv Crop Sci Tech* 6(330):7. <https://doi.org/10.4172/2329-8863.1000330>
- Actionaid International (2011) On the Brink: who's prepared for a climate and hunger crisis. Retrieved from <http://www.actionaid.org/publications/brink-whos-best-prepared-climate-and-hunger-crisis>. 2011, in *Third World News*
- Adebooye OC, Opabode JT (2004) Status of conservation of the indigenous leaf vegetables and fruits of Africa, 3(December), pp 700–705
- Aju P, Labode P, Uwalaka R, Iwuanyanwu U (2013) The marketing potentials of indigenous leafy vegetables in southeastern Nigeria. *Int J AgriSci* 3(9):667–677. Retrieved from [www.inacj.com](http://www.inacj.com)
- Ayanwale A, Oyedele D, Adebooye O, Adeyemo V (2011) A socio-economic analysis of the marketing chain for under-utilised indigenous vegetables in Southwestern Nigeria. In: African crop science conference proceedings, pp 515–519
- Ayyogari K, Sidhya P, Pandit MK (2014) Impact of climate change on vegetable cultivation – a review. *Int J Agric Environ Biotechnol* 7(1):145–155. <https://doi.org/10.5958/j.2230-732X.7.1.020>
- Boko M, Niang I, Nyong A, Vogel C, Githeko A, Medany M (2007) Africa. In: Parry ML, Canziani OF, Palutikof JP, van der Linden PJ, Hanson CE (eds) *Climate change 2007: impacts, adaptation, vulnerability. Contribution of working group II to the fourth assessment report of the intergovernmental panel on climate change*. Cambridge University Press, Cambridge, UK
- Chepkoech W, Mungai NW, Stöber S, Bett HK, Lotze-Campen H (2018) Farmers' perspectives: impact of climate change on African indigenous vegetable production in Kenya. *Int J Clim Change Strat Manag* 10(4):551–579. <https://doi.org/10.1108/IJCCSM-07-2017-0160>
- Ching LL, Stabinsky D (2011) Ecological agriculture is climate resilient, Third World Network – TWN Durban Briefing Paper (No. 1). Retrieved from [www.twinside.org.sg](http://www.twinside.org.sg)
- Chivenge P, Mabhaudhi T, Modi AT, Mafongoya P (2015) The potential role of neglected and underutilised crop species as future crops under water scarce conditions in sub-Saharan Africa. *Int J Environ Res Public Health* 12(6):5685–5711. <https://doi.org/10.3390/ijerph120605685>
- Devi AP, Singh MS, Das SP, Kabiraj J (2017) Effect of climate change on vegetable production – a review. *Int J Curr Microbiol App Sci* 6(10):447–483. <https://doi.org/10.20546/ijemas.2017.610.058>
- Ebert AW (2014) Potential of underutilized traditional vegetables and legume crops to contribute to food and nutritional security, income and more sustainable production systems. *Sustainability (Switzerland)* 6(1):319–335. <https://doi.org/10.3390/su6010319>

- Enete IC (2014) Impacts of climate change on agricultural production in Enugu state, Nigeria. *J Earth Sci Clim Change* 5(9):3. <https://doi.org/10.4172/2157-7617.1000234>
- Eyzaguirre P, Padulosi S, Hodgkin T (1999) Priority setting for underutilized and neglected plant species of the Mediterranean region. In: Padulosi S (ed) IPGRI's strategy for neglected and underutilized species and the human dimension of agrobiodiversity. International Plant Genetic Resources Institute, Aleppo, pp 1–20
- Fadairo O, Williams PA, Nalwanga FS (2019) Perceived livelihood impacts and adaptation of vegetable farmers to climate variability and change in selected sites from Ghana, Uganda and Nigeria. *Environ Dev Sustain*. <https://doi.org/10.1007/s10668-019-00514-1>
- Guarino L (1997) Traditional Africa vegetables: promoting the conservation and use of underutilized and neglected crops. In: Proceedings of the IPGRI International Workshop on Genetic Resources of Traditional Vegetables in Africa, Rome
- Howden M, Soussana JF, Tubiello FN (2007) Adaptation strategies for climate change. *Proc Natl Acad Sci* 104:19691–19698
- Intergovernmental Panel on Climate Change (2014) Climate change 2014 synthesis report summary chapter for policymakers. IPCC
- IPGRI (2002) Neglected and underutilized plant species: strategic action plan of the International Plant Genetic Resources Institute, Rome
- Kothari CR (2004) Research methodology, methods and techniques (second rev). New age International (P) Limited, Publisher, New Delhi
- Lemmi LK (2013) Climate change perception and smallholder farmers' adaptation strategy: the case of Tole District, Southwest Showa Zone, Oromiya Regional State, Ethiopia. Department of Rural Development and Agricultural Extension, Haramaya University
- Mabhaudhi T, O'Reilly P, Walker S, Mwale S (2016) Opportunities for underutilised crops in southern Africa's post-2015 development agenda. *Sustainability* 8(4):302. <https://doi.org/10.3390/su8040302>
- Mahouna A, Fadina R, Barjolle D (2018) Farmers' adaptation strategies to climate change and their implications in the Zou Department of South Benin. *Environments* 5(15):17. <https://doi.org/10.3390/environments5010015>
- Maroyi A (2011) Potential role of traditional vegetables in household food security: a case study from Zimbabwe. *Afr J Agric Res* 6(26):5720–5728. <https://doi.org/10.5897/AJAR11.335>
- Nnamani C, Oselebe H, Agbatutu A (2009) Assessment of nutritional values of underutilized indigenous leafy vegetables of Ebonyi State, Nigeria. *Afr J Biotechnol* 8(9):2321–2324
- Omatseye TR (2009, September 28) Speech by the Director General, NIMASA, at the 2009 World Maritime Day Celebrations, Abuja, Nigeria. In: Iwori J (ed) GLOBAL WARMING: poverty to worsen in Nigeria. THISDAY Newspaper, p 31
- Padulosi S, Hoeschle-Zeledon I (2004) Underutilized plant species: what are they? *Leisa Magazine*, 5
- Padulosi S, Heywood V, Hunter D, Jarvis A (2011) Underutilized species and climate change: current status and outlook in crop adaptation to climate change. (eds: Yadav SS, Redden RJ, Hatfield JL, Lotze-Campen H, Hall AE). Blackwell, Oxford
- Raghuvanshi RS, Singh R (2001) Nutritional composition of uncommon foods and their role in meeting in micronutrient needs. *Int J Food Sci Nutr* 32:331–335
- Sambo BE (2014) Endangered, neglected, indigenous resilient crops: a potential against climate change impact for sustainable crop productivity and food security. *J Agric Vet Sci* 7(2):34–41
- Shrestha D (2013) Indigenous vegetables of Nepal for biodiversity and food security. *Int J Biodivers Conserv* 5(March):98–108. <https://doi.org/10.5897/IJBC11.124>
- Tanton T, Haq N (2008) Climate change: an exciting challenge for new and underutilized crops. In: Smartt J, Haq N (eds) New crops and uses: their role in a rapidly changing world. Centre for Underutilized Crops, University of Southampton, Southampton
- Uddin MN, Bokelmann W, Entsminger JS (2014) Factors affecting farmers' adaptation strategies to environmental degradation and climate change effects: a farm level study in Bangladesh. *Climate* 2:223–241. <https://doi.org/10.3390/cli2040223>

**Open Access** This chapter is licensed under the terms of the Creative Commons Attribution 4.0 International License (<http://creativecommons.org/licenses/by/4.0/>), which permits use, sharing, adaptation, distribution and reproduction in any medium or format, as long as you give appropriate credit to the original author(s) and the source, provide a link to the Creative Commons license and indicate if changes were made.

The images or other third party material in this chapter are included in the chapter's Creative Commons license, unless indicated otherwise in a credit line to the material. If material is not included in the chapter's Creative Commons license and your intended use is not permitted by statutory regulation or exceeds the permitted use, you will need to obtain permission directly from the copyright holder.





# Farmers' Adoption of Climate Smart Practices for Increased Productivity in Nigeria

# 27

B. E. Fawole and S. A. Aderinoye-Abdulwahab

## Contents

Introduction .....	496
Adoption Theory as a Conceptual Framework .....	497
Climate-Smart Agriculture (CSA) .....	500
Benefits of Climate-Smart Agriculture .....	501
Adoption of Climate-Smart Agricultural Practices by Rural Farmers in Nigeria .....	503
Challenges of Climate Smart Agriculture Practices .....	504
Conclusion and Recommendation .....	505
References .....	506

## Abstract

In a bid to reinforce the efforts of agricultural professionals within the domain of climate change studies and with particular emphasis on rural farmers in Nigeria, this chapter explores the mechanics for adoption of climate smart agricultural practices among rural farmers for an increased agricultural productivity. Climate-Smart Agriculture (CSA) is paramount to the success of farming activities today in the face of the menace of the impact of climate change. Climate Smart Agricultural

This chapter was previously published non-open access with exclusive rights reserved by the Publisher. It has been changed retrospectively to open access under a CC BY 4.0 license and the copyright holder is "The Author(s)". For further details, please see the license information at the end of the chapter.

B. E. Fawole

Department of Agricultural Extension and Rural Development,  
Federal University, Dutsinma, Nigeria  
e-mail: [bfawole@fudutsinma.edu.ng](mailto:bfawole@fudutsinma.edu.ng)

S. A. Aderinoye-Abdulwahab (✉)

Department of Agricultural Extension and Rural Development,  
Faculty of Agriculture, University of Ilorin, Ilorin, Nigeria  
e-mail: [aderinoye.as@unilorin.edu.ng](mailto:aderinoye.as@unilorin.edu.ng)

© The Author(s) 2021

W. Leal Filho et al. (eds.), *African Handbook of Climate Change Adaptation*,  
[https://doi.org/10.1007/978-3-030-45106-6\\_227](https://doi.org/10.1007/978-3-030-45106-6_227)

495

Practice (CSAP) is one of the major keys that agricultural development approaches aimed at; to sustainably increase productivity and resilience, while also reducing the effects; as well as removing emissions of greenhouse gases. It is pertinent to note that most of the CSAPs adopted by the rural farmers in this study are conservation agriculture, use of organic manure, crop diversification, use of wetland (Fadama), planting of drought tolerant crops, relocation from climate risk zones, prayers for God's intervention, and improvement on farmers' management skills. This study divulged and showcased the import of CSAP in boosting agricultural yield and also highlights the bottlenecks inhibiting agricultural farming practices such as lack of practical understanding of the approach, inadequate data and information, lack of suitable tools at local and national levels, supportive and enabling policy frameworks, and socioeconomic constraints at the farm level. The study concluded by recommending an aggressive awareness and mobilization campaign to boost the adoption of CSAPs in Nigeria.

---

**Keywords**

Rural areas · Agricultural risks and productivity · Policy · Relocation · Greenhouse gases

---

## Introduction

Agriculture plays a huge role in Africa's economy with about 70% of the continent's population practicing subsistence farming for their livelihood while they equally live in the rural areas. Hence, the significance of this sector in providing employment and motivating economic growth in a developing nation such as Nigeria cannot be undermined. Agriculture mainly hinges on environmental factors and any prolonged variations in average weather conditions can have significant impacts on production. Additionally; agriculture as practiced in the continent, is highly characterized by land tenure insecurity which continues to hamper agricultural growth for millions of smallholder farmers; while poor soil fertility, degraded ecosystems and climate variability are among other problems associated with agriculture in Africa (USAID 2016). Climate change adaptation has to do with any spontaneous and/or premeditated action/mechanism adopted to deal/cope with the impacts of, or reduce vulnerability to, a changing climate.

Adaptation should address immediate problems and anticipate future changes in order to mitigate adverse effects. The strategies applied in adaptation can be preventive or reactive while all the methods taken should aim at enhancing resilience and reducing vulnerability (IPCC 2012). There is a dire need to deliberately advance a rigorous implementation of the identified strategies for adaptation and mitigation. This is in a bid to minimize the effects of climate change in order that development in agriculture can be encouraged. Mitigation refers to measures that may either reduce the increase in greenhouse gases (GHGs) emissions or increase terrestrial storage of carbon, while adaptation refers to all the responses to climate change that may be



used to reduce vulnerability (Ifeanyi-obi and Nnadi 2014). Indeed, there have been deliberate efforts by Heads of States to integrate approaches that have been employed to solve the impacts of climate variability. Evidence is seen in the authorization of governments to support at least twenty-five million farming households to adopt Climate Smart Agriculture (CSA) by 2025. (African Climate Smart Agriculture Summit 2014).

The concept of CSA, which came into limelight in 2010, is defined as a form of agriculture that increases agricultural production and income; enhances adaptation and build resilience to climate change impact. CSA also helps to reduce the emissions due to Greenhouse gases (GHGs) and enhances the attainment of global food safety (World Bank 2010; FAO 2014). Climate-smart ideas include activities that would ensure minimum tillage; application of organic agricultural practices rather than inorganic methods that would further deplete the soil in the long term; crop rotation and mulching to reduce evapotranspiration; and composting and planting of legumes and cover crops which assist in moderating the long-term effects of climate change by giving an enduring environmental strength to the soil (Olorunfemi et al. 2019; Ojoko et al. 2017). This chapter therefore sets to explore the CSAPs available, the benefits accruable from practicing CSA in order to increase productivity and the challenges hindering their adoption in Nigeria.

---

## Adoption Theory as a Conceptual Framework

The choice of adopting a technology is preceded by a number of certain mental processes which include: Awareness, Interest, Evaluation, Trial, and Adoption. According to Ekong (2010), adoption process is the mental procedure from the first instance of learning of an idea/technology to the final stage of taking a decision to use it. The farmer's choice to accept or reject a technology is based on their perception of those stages earlier mentioned. This implies that a farmer can only decide to use a technology only if he was aware of it; develops interest in it; and possibly, after he must have tried it and becomes convinced that the technology is beneficial to him.

**Awareness stage:** At this first stage, the farmer is barely conversant with the existence of an innovation; it could be that he only became cognizant of the technology and may be deficient in the technicalities such as how to use the innovation, the cost; as well as the benefits of the innovation. The farmer may learn of the existence of the innovation through friends, relatives, mass media, extension agents or local cooperative organization. After being aware of the innovation, the farmer might crave for more information. He may want to understand how the invention works and also the benefits and usefulness. Consequently, the farmer can take the next step of making deep inquiries in order to access adequate information that would help him in reaching a decision.

**Interest stage:** during this second stage the farmer asks for detailed information concerning the technology. It is only normal that the farmer relies partly on their source (through which they became aware) of information to deepen their

knowledge about it. The farmer can also search for better understanding from other sources which hopefully spurs them to become interested in the technology. This makes the farmer to develop interest by asking further questions and collecting information about the new idea or new product to assess its potentialities. These line of questioning can make the farmer to become curious and begin to wonder how much he can benefit should he decide to try the idea/technology.

**Evaluation stage:** this is the stage where the farmer mentally appraises the applicability of the technology in light of the solution to his own circumstances. The farmer makes a mental assessment by asking several questions such as: Is it/this possible? Who do I know that has done it? What was their outcome? Can I also do it? What happened the last time someone tried it? The responses to these questions and many more that the farmer might have mentally asked would be the determinant of whether he would go ahead to try it or not? If the evaluation produces a negative result, the farmer could stop showing interest in the innovation and may eventually reject it. However, if the responses he got from his mental assessment were favorable, he may then be set to try the innovation practically.

**Trial stage:** this is the stage where the farmer essentially implements or applies the innovation on a small scale under his personal circumstances and managerial competence. The farmer could entirely handle the trial stage all alone or they may seek the help of change agents and sales promoters. In this stage, the farmer raises the question: how am I supposed to do it? The farmer uses the innovation on a trial/experimental basis on a portion or segment of their farm. The result, positive or negative, would then determine whether the farmer would take or discard the technology.

**Adoption stage:** The final stage of adoption is when the farmer eventually approves the innovation and has decided to continue using it on a full scale. In this stage, the farmer extends the use of the technology to their whole plots of land. Adoption involves an enduring acceptance and repeated utilization of the technology with the hope that it will help to ease a difficult farm situation. This suggests that a farmer may stop or discontinue the use of such innovation if subsequent outcomes do not prove reliable.

According to Adekoya and Tologbonse (2011), a prospective adopter has a number of characteristics to consider before concluding on whether to adopt an innovation or not. These characteristics are as listed:

1. **Relative advantage:** A technology must be perceived by the farmer as being better than the one currently in use. This can be measured in terms of profitability, low cost, and time saving ability. It could also be in terms of factors relating to social-prestige, convenience and satisfaction. The point that matters in this case is the discernment of advantage as perceived by the adopter.
2. **Compatibility:** This means that the new idea being professed is in consonance with the obtainable values, beliefs, ancient times experiences, and desires of prospective adopters. Hence, any innovation that does not conform with the standards of a community may not be accepted as fast as one that is compatible.

3. **Complexity:** Some technologies are easily and willingly understood by majority of farmers in a community; whereas, others are more difficult and will take more time before they get accepted. Therefore, new ideas should be comparatively easy to comprehend and utilize when compared to existing ones as innovations that are simple to comprehend are accepted more rapidly.
4. **Trial-ability:** An innovation should normally be easily adaptable. What this implies is that, it will be possible to try a technology on a small scale. Any innovation that can be experimented on an installment arrangement will usually be more readily accepted than ideas that are not separable.
5. **Observability:** Farmers would normally want to be able to see the outcome of a new idea so that they could be able to discuss such results with fellow farmers. If outcomes of innovation are readily seen by farmers, then the chances of accepting such innovation become higher; whereas if there are no clear observable outcomes, it may be difficult for such ideas to be replicated and accepted.
6. **Divisibility:** It is a great idea for a technology to be divisible; this means that the innovation can be tested with small units before buying the whole gadget. Purchase of tractors or harvesters is a one-time major investment and part of it cannot be bought in order to try it out in phases. However, such technology can be hired for initial use before deciding on whether to purchase. A farmer can however, purchase and utilize a little quantity of improved seeds, fertilizer or herbicides.
7. **Accessibility:** Innovations that are easily available are more readily accepted. In this case, it is not advisable for a change agent to push for the distribution of farming inputs that farmers either cannot afford or for which infrastructure does not exist; as this would be an indication that the technology is not accessible.
8. **Visibility:** The results of the mode of operation of a given innovation should be easily seen, i.e., visible. A farmer can see a new spraying pump which has been made easier to handle; hence the likelihood of adoption becomes greater.
9. **Cost:** It has been consistently observed that innovation may not be easily adopted if it is perceived to be costlier than what currently exists; it thus goes to say that a new idea may have a relative advantage over an old one; but could meet up with resistance if the currently used practice is a lot cheaper. Generally, the higher the cost of an innovation, the more slowly it is adopted.

However, Rogers (2003) as cited by Ray (2011) argued that the choice to accept any part of an innovation depends on a procedure which is known as the innovation-decision process. Innovation-decision is conceptualized as having five stages and each of these stages can only take place after a period of time has passed. The stages are:

1. Knowledge stage: One is believed to have acquired knowledge the very moment a person is exposed to the technology reality and has achieved some perception of how such knowledge functions. The meaning of this is that knowledge role is primarily cognitive or knowing. People who acquire knowledge at an early stage; are regarded as generally more highly educated and are perceived as having higher social status; they are also more open to both mass media and interpersonal channels of communication, and they have more contact with change agents.

2. Persuasion stage: One would have passed through the persuasion stage once a person forms an opinion about the new practice/idea; though this could only happen after going through several persuasive messages from development workers, sales promoters and close associates. The persuasion function is mainly connected or related to feelings and is thus; a stage laden with so much emotional attachment and/or factors. Hence, it is expected that the potential adopter may turn out to be more psychologically involved with the innovation and would actively seek information about the innovation/new practice. It is at this stage that the would-be adopter forms a good or bad attitude/impression towards the technology.
3. Decision stage: After being persuaded about the usefulness or benefits of an innovation, one would normally engage in activities which may culminate into either of two options; that is whether to take or discard the technology. Having observed that other people use the innovation, the potential adopter can choose to adopt or refuse the technology. People would adopt an innovation only if they are convinced of its usefulness and compatibility with their values and income.
4. Implementation stage: Implementation happens as soon as a person or other decision-making unit place a technology into use. At this stage the individual is generally concerned with where to get the innovation, how to use it and what operational problems will be faced and how those problems could be solved. Implementation might entail alteration in management of the venture and/or adjustment in the technology, to go well with the exact needs of the individual who accepts it.
5. Confirmation stage: This is the last stage in the innovation process when an individual finally accepts or rejects a new practice. Confirmation culminates in repeated use. Individuals seek reinforcement for the adoption decision they have made. The consequence is that they may exhibit continued adoption or exhibit discontinuance. Meanwhile, it is noteworthy to mention that the entire innovation-decision process has a sequence of options at every stage. For instance, in the knowledge function, the would-be adopter would have to decide on which of the innovation messages to attend to while they also have to make up their minds on which ones to disregard.

In the persuasion function, potential adopters must decide on the messages to seek out and the ones to ignore, whereas; in the decision function, the available options are different from what were obtainable in the previous stages. The decision stage presents with two possibilities which are either to accept or refuse a new idea. This decision involves an immediate consideration of having to try out an innovation or not to give it a try at all. Most farmers will accept an idea/technology only after trying it out; and it is after the trial that he can then determine its suitability.

---

## **Climate-Smart Agriculture (CSA)**

CSA derives from an attribute in its terminology; that is, smart way of practicing agriculture. It is a form of agriculture that sustainably increases agricultural output and earnings; it enhances adaptation and aims to build resilience to the effect of

climate change by reducing or eliminating Greenhouse Gases (GHGs) wherever possible, as well as advancing the attainment of global food safety (FAO 2014). CSA is mainly targeted at integrating the three broad areas of sustainable development which are the economic, social, and environmental components; by equally justifying food security, ecosystem management, and climate change problems.

Food security can be enhanced by maintaining an increasing agricultural production efficiency while the ecosystem can be more easily managed by adapting to, as well as building resilience to climate change. On the other hand, the climate change problems can largely be well mitigated by either working to lessen and/or eradicate greenhouse gases (GHG) emissions. However, CSA is never a pre-arranged condition, neither is it a given template that can be generally applied or practiced. Suffice to say that, it is a process that calls for site-specific assessments of the social, economic and ecological conditions to identify proper farming technologies that are appropriate in any given situation. It is important to note that a key component of CSA is the incorporated landscape method which suggests that the CSA practices that are being employed and/or applied in a given environment would follow the main beliefs of ecosystem management and sustainable land and water utilization. Climate-smart agriculture aims at supporting livelihoods at farm level by ensuring food security of smallholder farmers and helping to improve the management and utilization of natural resources. It also fosters the adoption of appropriate methods and skills for the production, processing and marketing of agricultural supplies. Whereas at the national level, CSA pursues legitimate and relevant technological and financial policies that would support nations to establish/entrench climate change adaptation into their agricultural sector. There is, at the national level, a considerable progressing efforts to promote CSA in Africa while ECOWAS also made efforts to support the mainstreaming of CSA into the ECOWAP/CAADP programs (ECOWAS 2015). In Nigeria specifically, there are research institutions and colleges owned by the Federal Government; who are working on CSA in order to render their own contribution to the fight against climate change related problems (FAO and ICRISAT 2019).

---

## **Benefits of Climate-Smart Agriculture**

Climate-smart agriculture, as noted earlier, underscores the importance of building evidence to highlight practicable alternatives to the existing non-climate friendly approaches. It also encourages important enabling activities that can translate into better productivity and a friendlier environment. Through CSA, attention can be drawn to agricultural systems (crop, livestock, aquaculture, and agroforestry) that support the ecosystem services as this would enhance productivity, adaptation and mitigation; in a way that would encourage smart farming practices in order to reduce the effect of climate change (Adedeji et al. 2017). The CSA process offers stakeholders, such as farmers and other main players in the sector; the techniques and gadgets, as well as management and styles required to regulate more challenging and tougher production systems.

The FAO, who has immensely contributed to the development of CSA in Africa, also trained numerous individuals on the CSA approach and have equally developed a program called Safe Approach to Fuel and Energy (SAFE) in northeast Nigeria (FAO 2019). The SAFE program is aimed at reducing the need for firewood and by extension, the release of greenhouse gas is further reduced. Among the documented efforts at reducing the impact of climate change is the Oxfam Nigeria and the European Union collaboration which designed a project named Pro-Resilience-Action (PROACT). PROACT started in Nigeria in 2016 with enhancement of food security as its purpose while helping farmers build enduring means of sustenance (FAO and ICRISAT 2019a). The project has Mubi South, Fufore, Song, and Guyuk local government areas (LGAs) of Adamawa State currently participating where certain relevant and appropriate climate-smart actions are being combined to support farmers become more resilient. Some of the actions, which are rolled out in phases, are provision of farm inputs and training of farmers' groups.

In the four locations of Adamawa State (Mubi South, Fufore, Song, and Guyuk), inputs such as fertilizers and water pumps are supplied to farmers while extension workers are being trained on rural investments and formation of loan groups in order to enable them access flexible financing services (FAO and ICRISAT 2019a). So far, about 700 farmer groups (women constitute more than half of the population) have been provided with farm inputs. The scheme has documented some level of success as rice growers have seen a boost of almost 100 percent despite the dry season rice production (Adedeji et al. 2017). This was made possible due to the distribution of inputs such as improved seeds, water pumps, among others. The project did not only focus on input provision for farmers as about 70 government extension workers in Kebbi and Adamawa States have received training on better environment-friendly agricultural practices for improved cereals production (Adedeji et al. 2017; FAO and ICRISAT 2019a). Farmer Training Fields (FTF) were then established wherein the extension workers in PROACT Communities assist farmers in order to boost their capacity as well as support them to adopt the best practices that can improve their yields and productivity. It has been observed through field evidences that the FTF program has contributed to higher acceptance of CSAPs and this has translated into enhanced food safety and income for farmers (FAO and ICRISAT 2019a).

In the short run, the project aims to handover improved farming skills to farmers as well as equip them to plant 500,000 trees to battle desertification and climate change; while in the long run, it is expected that about 1,400 community investments and loan groups would have been established. Another observable CSA effort is seen in adoption of terracing as a climate-smart practice in the southern and northern parts of Borno State as a result of the rocky topography of the area (FAO and ICRISAT 2019b). A farmer, while confirming the use of terracing (even without the knowledge or advent of CSA) for more than forty years, confirmed that it helped to combat the effects of soil erosion by preserving moisture and crop nutrients on the farm.

The farmer affirmed a higher yield of sorghum and maize on terraced farms (47% higher) when compared to non-terraced ones. Added to the advantage of terracing in the area is the assertion that farm events such as weeding and spraying are better managed on terraced farms while suggesting that farming in the entire southern part

of Borno might have been very unprofitable if terracing was not being practiced (FAO and ICRISAT 2019b). Among the manifestation of the benefits of CSAPs is yet another evidence as provided by a farmer, in Potiskum LGA of Yobe State, who planted improved variety of millet (SOSAT) and got higher yields over and above the traditional variety (Gwagwa) that he had been planting previously (FAO and ICRISAT 2019c). Given the nature of local farmers, he initially resisted the new SOSAT variety as a replacement for his Gwagwa local variety. Hence, he intercropped SOSAT and Gwagwa millets with sorghum and cowpea as commonly practiced around Potiskum. This was done for 4 years while monitoring the variations in yield (FAO and ICRISAT 2019c). The farmer realized 550 kg/ha from the traditional millet while SOSAT millet produced 900 kg/ha in the first year. The following 2 years, on the same plots, but only intercropped with cowpea without sorghum, produced 350 kg/ha of SOSAT over the traditional variety. The first year reflected a marked increase of 64% yield over the utilization of the traditional local variety while the next year produced yield increase of 88%. This field experiment is yet another indication that climate-smart options, such as planting of improved varieties, could help enhance crop output and diversification which can also potentially increase profits of farmers (Tiarniyu et al. 2018b; FAO and ICRISAT 2019c).

---

## Adoption of Climate-Smart Agricultural Practices by Rural Farmers in Nigeria

Smallholder farmers have, in the past, accidentally practiced CSA as part of their habitual farming system in Northern Nigeria (Fanen and Olalekan 2014). Similarly, it was also found in another study that the foremost strategy adopted by farmers to deal with climate change was to plant drought resistant varieties (Naswem et al. 2016). Other strategies used in mitigating the effect of climate change include: relocation from climate risk zones, prayers to God for divine intervention, multiple cropping, recycling of waste product, and improvement on farmers' management skills. According to Ojoko et al. (2017), the five most used CSAPs in Nigeria included conservation agriculture, application of organic manure, crop diversification, usage of wetland (Fadama), planting of drought tolerant crops, and agro-forestry. Tiarniyu et al. (2017) in their study also reported similar findings where the adoption of CSAPs included climate smart approaches such as planting of drought tolerant and early maturing varieties, application of organic compost, use of cultural practices such as intercropping and crop rotation, composting rather than burning, and erection of terraces on sloppy/hilly farmland.

In other studies, Onyeneke et al. (2018) also reported that mixed farming, high yielding cultivars, agro-forestry, and other cultural practices such as mulching and zero tillage, as well as membership in development associations were the CSAPs adopted by the farmers in their study. Further evidence had showed that farmers in Nigeria have continued to adopt climate smart practices to mitigate the effect of climate change while simultaneously increasing productivity. For instance, female farmers adopted agro-forestry in derived savannah, guinea savannah, and rain forest,

while the male farmers employed organic manure, zero tillage, and crop rotation in the same agro-ecological zones, respectively (Fapojuwo et al. 2018). However, it was observed that majority of farmers in the study never made use of the climate smart practices; hence low adoption rate because they were not even aware of the opportunities (Tiamiyu et al. 2018a). Nonetheless, planting of drought tolerant varieties and high yielding cultivars appear to be the most favored options accepted by farmers while only a few of the farmers used agro-forestry and integrated pest management as a smart way to curb the effect of climate change. Moreover, Adebayo and Ojogu (2019), in their study, had reported minimum or zero tillage, crop rotation, and other cultural practices such as mulching as the most favored CSAPs by farmers.

---

## Challenges of Climate Smart Agriculture Practices

The adoption of CSAPs is linked to a myriad of impediments as there is an array of socio-economic and institutional complications. As usual, the need for significant upfront expenditures on the part of poor farmers, inadequate access to technical information that are potential solutions to farmers' problems, and the inability of farmers to convert the knowledge gained into practice; are part of the challenges associated with the adoption of CSAPs. Furthermore, some procedures that are climatically smart in nature and which are also associated to sustainable soil management may not be compatible with farmers' customs; thereby leading to non-adoption as previous studies have shown that, the onward dissemination of ideas may greatly rely on knowledge in combination with social activities that farmers may not be capable of performing (World Bank 2018).

It had been reported that lack of funding portends a huge bottleneck in the acceptance of CSAP in Northern Nigeria while farmers also have little or no knowledge of CSAP; in addition to a poor understanding of the application of some of those practices by extension workers who would normally be the ones to disseminate technology to the farmers. Other challenges include a dearth of stakeholders such as nongovernmental organizations; who can drive the campaign for CSAPs in the region (Fanen and Olalekan 2014). Moreover, while dealing with climate change, desertification poses a big threat for people, farmers inclusive. Hence, the subtle drive for tree planting by a few organizations makes the situation more problematic; thereby suggesting a neglect of the root cause. The implication of this is that there is a real need for a holistic and aggressive mobilization for tree planting. Meanwhile, limited opportunities for local managers to partake in policy formulation/decisions at international and local levels is a further weakness in the effort to combat climate change impact by encouraging adoption of CSAPs. Other hindrances restraining farmers from using CSAPs include: lack of government's support, high cost of executing the practices, and insufficient training on the practices (Adebayo and Ojogu 2019). Specific challenges of CSA, according to Williams et al. (2015) are outlined:



1. Lack of practical understanding of the approach: The need for a full comprehension of protocols surrounding the use of CSAPs is important in order for messages to be clearly communicated to farmers. Thus, the effort for scaling up initiatives will depend on the understanding of the CSA idea by relevant stakeholders.
2. Inadequate data and information: It is always a herculean task for African nations both at national and local levels to access and utilize suitable tools for climatic and landscape level data.
3. Inadequate investment in CSA: Again, it has been repeatedly found that investments required to scale up adaptation and resilience in agriculture is lacking right from national up to farm levels. The Africa's Infrastructure Diagnostic Report (Foster and Briceño-Garmendia 2010) also reported a deficit in social infrastructure such as road, transportation, communication, power and water; which are high requirements for the uptake of CSAP.
4. Socio-economic constraints: Access to productive resources like land, transportation and water, as well as human resources were the limitations at the farm level.
5. Inadequate women empowerment: Women who contribute significantly to food production in Africa are largely marginalized when it comes to access to and control over productive resources. For instance, it was found in a previous study carried out in northern Nigeria that women do not own and control productive assets such as land, crop inputs, livestock inputs, and capital (Aderinoye-Abdulwahab et al. 2016) and that this makes them to be poorly empowered. It is noteworthy that such gender stereotypes relating to access to land rights, education, technologies, and credit; are among the countless stumbling blocks to women's effective contribution in the farming sector.
6. Poor funding and efficient risk-sharing schemes: Funding devices to support the uptake of CSAP are not yet popular in Africa nations. Whereas, huge investment is required for the transition to climate-smart agricultural development pathways as farmers continue to face the risk of accepting new technologies. Meanwhile, the benefits of the technologies often only come after several years/seasons of production, thus the realization of a wider coverage of CSAPs becomes problematic.
7. Difficulty in running trade-offs from the farmers' and policymakers' perspectives: The dissimilarity in objectives between farmer groups and policy makers continues to cause a difference of opinion in respect of priorities for resource management.

---

## Conclusion and Recommendation

The adoption of smart agricultural practice is an integral part for increasing agricultural productivity as it enhances adaptation to climate change. It also helps to reduce greenhouse gases emissions while enhancing the attainment of food security. The popular CSAPs adopted by rural farmers in Nigeria are: conservation agriculture, adoption of organic compost, use of wetland (Fadama), utilization of drought

tolerant crops, relocation from climate risk zones, and use of cultural and management practices such as mulching and prayers for divine intervention. The challenges militating against the adoption of CSAPs by farmers in the study include: poor funding, lack of practical understanding of the approach, inadequate access to information on CSAPs, and socio-economic constraints at the farm level.

It would, hence, be recommended that there is a dire need for an aggressive awareness and mobilization campaign for the use of CSAPs as a solution to climate change impact in order to increase farmers' productivity. Additionally, this chapter would also recommend that government and other stakeholders should ensure that productive resources such as land, planting technologies, education and other social amenities be made available and accessible to farmers generally, but more especially women; in order to facilitate easy uptake of climate smart practices. Moreover, there is a need to motivate and encourage farmers to adopt climate smart practices, and one way of achieving this is by incorporating funding devices to support CSAPs and other climate friendly support mechanisms in policy documents.

---

## References

- Adebayo AE, Ojogu EO (2019) Assessment of the use of climate smart agricultural practices among smallholder farmers in Ogun state. *Acta Sci Agric* 3(6):47–56
- Adedeji IA, Tiku NE, Waziri-Ugwu PR, Sanusi SO (2017) The effect of climate change on rice production in Adamawa State, Nigeria. *Agroecologia Croatica* 7(1):1–13. ISSN 1333-2422
- Adekoya AE, Tologbonse EB (2011) Adoption and diffusion of innovations; agricultural extension in Nigeria, 2nd edn. *Agric Exten Soc Niger*, Ilorin, pp 36–48
- Aderinoye-Abdulwahab SA, Dolapo AT, Matanmi BM, Adisa RS (2016) Ownership of productive resources: a panacea for empowering rural women in Kwara state, Nigeria. *J Prod Agric Technol* 12(1):17–26
- African Climate Smart Agriculture Summit (2014) Twenty-third ordinary session. Equatorial Guinea, Malabo. 26–27 June 2014. <http://africacsa.org/introducing-the-africa-csa-alliance-ascaa/>
- ECOWAS (2015) A Thematic Roundup of Research, decision-making support and capitalization-extension of endogenous and scientific knowledge for the CSA in the ECOWAS/UEMOA/CILSS region. Paper prepared for the High Level Forum of Climate-Smart Agriculture (CSA) Stakeholders in West Africa, Bamako, 15–18 June 2015
- Ekong EE (2010) An introduction and analysis of rural Nigeria, 3rd edn. Dove Educational Publishers, Uyo, pp 280–266
- Fanen T, Olalekan A (2014) Assessing the role of climate-smart agriculture in combating climate change, desertification and improving rural livelihood in Northern Nigeria. *Afr J Agric Res* 9 (15):1180–1191
- FAO (2014) Innovation in family farming. The State of Food and Agriculture Series. A production of Food and Agricultural Organization of the United Nations, Rome. E-ISBN 978-92-5-108537-0. Available at: <http://www.fao.org/3/a-i4040e.pdf>. 161p
- FAO (2019). <http://www.fao.org/faostat/en/#data/GT>
- FAO, ICRISAT (2019a) Climate-smart agriculture in the Adamawa state of Nigeria. CSA Country Profiles for Africa Series. International Center for Tropical Agriculture (CIAT); International Crops Research Institute for the Semi-Arid Tropics (ICRISAT); Food and Agriculture Organization of the United Nations (FAO), Rome. 22p

- FAO, ICRISAT (2019b) Climate-smart agriculture in the Borno state of Nigeria. CSA Country Profiles for Africa Series. International Center for Tropical Agriculture (CIAT); International Crops Research Institute for the Semi-Arid Tropics (ICRISAT); Food and Agriculture Organization of the United Nations (FAO), Rome. 22p
- FAO, ICRISAT (2019c) Climate-smart agriculture in the Yobe state of Nigeria. CSA Country Profiles for Africa Series. International Center for Tropical Agriculture (CIAT); International Crops Research Institute for the Semi-Arid Tropics (ICRISAT); Food and Agriculture Organization of the United Nations (FAO), Rome. 22p
- Fapojuwu OE, Ogunnaiké MG, Shittu AM, Kehinde MO, Oyawole FP (2018) Gender gaps and adoption of climate smart practices among cereal farm households in Nigeria. *Niger J Agric Econ* 8(1):38–49
- Foster V, Briceño-Garmendia C (2010) Africa's infrastructure. A time for transformation. A copublication of the Agence Française de Développement and the World Bank. World Bank, Washington, DC
- Ifeanyi-obi CC, Nnadi FN (2014) Climate change adaptation measures used by farmers in South-South Nigeria. *J Environ Sci Toxicol Food Technol* 8(4):1–6. <https://pdfs.semanticscholar.org/a63d/22bf8b8ebde892a7c9d761ee1653e0e11df6.pdf>
- IPCC (2012) Managing the risks of extreme events and disasters to advance climate change adaptation. a special report of working groups I and II of the Intergovernmental Panel on Climate Change (eds: Field CB, Barros V, Stocker TF, Qin D, Dokken DJ, Ebi KL, Mastrandrea MD, Mach KJ, Plattner G-K, Allen SK, Tignor M, Midgley PM). Cambridge University Press, Cambridge/New York, p 582
- Naswem AA, Akpehe GA, Awuaga MN (2016) Adaptation strategies to climate change among Rice farmers in Katsina-Ala local government area of Benue state, Nigeria. *IOSR J Agric Veter Sci* 9 (10):33–37
- Ojoko EA, Akinwunmi JA, Yusuf SA, Oni OA (2017) Factors influencing the level of use of climate-smart agricultural practices (CSAPs) in Sokoto state, Nigeria. *J Agric Sci* 62(3):315–327
- Olorunfemi TO, Olorunfemi OD, Oladele OI (2019) Determinants of the involvement of extension agents in disseminating climate smart agricultural initiatives: implication for scaling up. *J Saudi Soc Agric Sci*. <https://doi.org/10.1016/j.jssas.2019.03.0031-8>
- Onyeneke RU, Igeri CO, Uwadoka CO, Ogbeni JA (2018) Status of climate-smart agriculture in Southeast Nigeria. *GeoJournal* 83:333–346. <https://doi.org/10.1007/s10708-017-9773-z>
- Ray GL (2011) Extension communication and management, 8th edn. Kalyani Publishers, New Delhi, pp 147–170
- Rogers E (2003) The diffusion of innovations. (5th ed.). New York, NY: The Free Press
- Tiamiyu SA, Ugalahi UB, Fabunmi T, Sanusi RO, Fapojuwu EO, Shittu AM (2017) Analysis of farmers' adoption of climate smart agricultural practices in Northern Nigeria. In: Proceedings of the 4th International Conference on Agriculture and Forestry, vol 3, pp 19–26
- Tiamiyu SA, Ugalahi UB, Eze JN, Shittu MA (2018a) Adoption of climate smart agricultural practices and farmers' willingness to accept incentives in Nigeria. *Int J Agric Environ Res* 4 (4):198–205
- Tiamiyu SA, Ugalahi UB, Fabunmi T, Sanusi R, Fapojuwu E, Shittu A (2018b) Analysis of farmers' adoption of climate smart agricultural practices in Northern Nigeria, pp 19–26. <https://doi.org/10.17501/icoaf.2017.3104>
- USAID (2016) Climate smart agriculture in feed the future programs. Feed THE Future (The U.S. Government's Global Hunger & Food Security Initiative). Available at: <https://www.climatelinks.org/sites/default/files/asset/document/Framework%20CSA%20paper%20final%20%281%29.pdf>. 13p
- Williams TO, Mul M, Cofie O, Kinyangi J, Zougmore R, Wamukoya G, Nyasimi M, Mapfumo P, Speranza CI, Amwata D, Frid-Nielsen S, Partey S, Girvetz E, Rosenstock T, Campbell B (2015) Climate smart agriculture in the African context. Abdou Dlouf international conference center, Feeding Africa an Action Plan for African Agricultural Transformation

World Bank (2010) Development and climate change. World Development report 2010. World Bank, Washington, DC

World Bank (2018) Scaling up climate-smart agriculture through the Africa climate business plan. World Bank, Washington, DC

**Open Access** This chapter is licensed under the terms of the Creative Commons Attribution 4.0 International License (<http://creativecommons.org/licenses/by/4.0/>), which permits use, sharing, adaptation, distribution and reproduction in any medium or format, as long as you give appropriate credit to the original author(s) and the source, provide a link to the Creative Commons license and indicate if changes were made.

The images or other third party material in this chapter are included in the chapter's Creative Commons license, unless indicated otherwise in a credit line to the material. If material is not included in the chapter's Creative Commons license and your intended use is not permitted by statutory regulation or exceeds the permitted use, you will need to obtain permission directly from the copyright holder.





# Climate Change Adaptation Strategies Among Cereal Farmers in Kwara State, Nigeria

# 28

S. A. Aderinoye-Abdulwahab and T. A. Abdulkaki

## Contents

Agriculture and Climate Change .....	510
Focus Study Site .....	512
Agriculture and Cereal Production in Nigeria .....	513
The Impact of Climate Variability on Agriculture in Nigeria .....	514
Climate Change Adaptation Strategies for Cereal Farmers in Nigeria .....	516
Conclusion .....	519
Recommendations .....	520
References .....	520

## Abstract

Agriculture is the art and science of food production which spans soil cultivation, crop growing, and livestock rearing. Over the years, it has served as a means of employment and accounts for more than one-third of total gross domestic product. Cereals, which include rice, maize, and sorghum, are the major dietary energy suppliers and they provide significant amounts of protein, minerals (potassium and calcium), and vitamins (vitamin A and C). The growth and good yield of cereal crop can be greatly influenced by elements of weather and climate such as temperature, sunlight, and relative humidity. While climate determines the choice of what plant to cultivate and how to cultivate, it has been undoubtedly identified as one of the fundamental factors that determine both crop cultivation and

This chapter was previously published non-open access with exclusive rights reserved by the Publisher. It has been changed retrospectively to open access under a CC BY 4.0 license and the copyright holder is “The Author(s)”. For further details, please see the license information at the end of the chapter.

S. A. Aderinoye-Abdulwahab (✉) · T. A. Abdulkaki  
Department of Agricultural Extension and Rural Development, Faculty of Agriculture, University of Ilorin, Ilorin, Nigeria  
e-mail: [aderinoye.as@unilorin.edu.ng](mailto:aderinoye.as@unilorin.edu.ng)

livestock keeping. The chapter, though theoretical, adopted Kwara State, Nigeria, as the focus due to favorable weather conditions that support grains production. It was observed that the effect of climate change on cereal production includes: drastic reduction in grains production, reduction in farmers' profit level, increment in cost during production, diversification to nonfarming activities, and discouragement of youth from participating in agricultural activities. Also, the adopted coping strategies employed by farmers in the focus site were early planting, planting of improved variety, irrigation activities, alternates crop rotation, and cultivation of more agricultural areas. The chapter thus concluded that climate change has negative impact on cereals production and recommends that government should provide communal irrigation facilities that will cushion the effect of low rains on farmers' productivity, while early planting and cultivation of drought-resistant cultivars should be encouraged.

---

**Keywords**

Grains · Crop rotation · Early planting · Irrigation · Yield

---

## **Agriculture and Climate Change**

Our ancestors advanced from being hunter gatherers to live a more settled lifestyle since about a thousand years ago, residing in one place for a lengthy period rather than living a nomadic lifestyle. This change happened concurrently with the taming of different species of plants and animals, which were bred, kept or planted in close proximity rather than hunted. Over the periods, agriculture continued to advance although, up until the twentieth century, most of the work were undertaken by mankind and animals rather than machines. Such fauna and flora activities (which could also be natural), including human's method of cultivation as well changes in weather and climate, left the environment in a tough situation that we now refer to as climate change and its impact. Agriculture is largely reliant on weather and climate, hence climatic factors such as rainfall, sunlight, airstream, and temperature influence the distribution and productivity of crops (Sokoto et al. 2016).

Of all human endeavors, agriculture remains one of the most demanding on land. Land is thus in constant short supply given the effects of biophysical factors such as rain, temperature, and topography of an area, as well as unsustainable land management practices which include deforestation, uncontrolled soil nutrient mining, and cultivation on steep slopes (FAO 2015). The implication of such effects on land may comprise overgrazing, desertification, soil erosion, deforestation, among others and all of these further translate into shortage of land for human's endeavors. Perhaps the continued presence of these effects is one of the reasons why scholars have maintained that the ozone layer may eventually be depleted given that the earth is warming up (IPCC 2007; Mboera et al. 2012; FAO 2015) as a result of people's activities which enable greenhouse gases (GHG) like methane, water vapor, nitrous oxide, and carbon dioxide to trap heat into space.

Climate, a manifestation of weather and other atmospheric conditions, has largely been acknowledged as one of the fundamental indicators that determine both crop cultivation and livestock keeping. It is a long-term average weather conditions that directly or indirectly impact the events that play out on farms. Climatic conditions of any environment govern the choice of crop and how they will be planted, as well as the yields and nature of livestock to keep in a given location. This statement is alluded to in the work of Ajadi et al. (2011) where it was similarly shown that biophysical factors such as sunlight energy, temperature, humidity, and other climatic variables determine the global distribution and yield of crops and livestock. On the other hand, climate change is the long-term change in average temperature as a result of the earth's warming which may eventually translate into the depletion of the ozone layer. Although, an inconsistent phenomenon, climate change points clearly at threats to the future of people through the depletion of the ozone layer, thereby negatively impacting on all segments of human endeavor, agriculture inclusive. As a result of human and natural activities that release greenhouse gases (GHG) which had hitherto trapped heat within the atmosphere (Mboera et al. 2012), higher concentrations of these gases in the atmosphere leads to the earth's warming. These human activities could include but not limited to: use of fossil fuel, land use change, and agriculture (IPCC 2007; Mboera et al. 2012; Omumbo et al. 2011). Many people in developed regions prefer to assume that climate change is not real than to prepare to adjust their living standards to suit the effect of climate change (Mboera et al. 2012). Hence, there is a need to increase farmers' awareness on the effect of climate change as well as adequately prepare for its mitigation. Researches to proffer ease of living with climate change and its impact are therefore expedient.

It has equally been shown in another instance that the planet's temperature is increasing, leading to frequent changes in rainfall patterns and extreme events such as droughts (Zoellick 2009). The International Panel of Climate Change (IPCC 2007) also submitted that agriculture, forestry, and the change in land use, account for up to 25% of human induced GHG emissions while agriculture is the chief source of released methane and nitrous oxide, bearing in mind that these two gases constitute the substantial part of GHGs. Similarly, Odjugo (2010) stated that climate change is undeniable and its impacts are clearly seen in rising temperatures, low rainfalls, desertification, water scarcity, health, and agricultural problems. It has also been reported that several million hectares of crops and livestock have been destroyed due to climate-induced tragedies (FAO 2015). Climate change has therefore impacted on the economy of nations so much so that agriculture sector absorbs about 22% of the entire damage in developing countries (FAO 2015). Therefore, there is a dire need for farmers to be aware of the extent of destruction that the impact of climate change can constitute in their livelihoods as this will work to boost their preparedness for its mitigation. Reuben and Barau (2012) had similarly reported that incidences of low humidity during propagative stage will definitely result in poor yields of crops while the Food and Agriculture Organization (FAO) also poised that the crop sector is the most affected during unfavorable weather episodes (FAO 2015).

It is imperative to note that countries would feel the impact of climate change differently; while the effect may be positive in some areas, other climes might be

negatively affected. Some additional degree of climate change and its impact is unavoidable regardless of the amount of measures put in place to ameliorate or forestall it. As such, there is an inevitable need to adapt farming to resilient conditions of agricultural systems. The two major means of reducing climate impact are mitigation and adaptation. Adapting agriculture to climate change and sustaining adequate food production could help to resolve the current glitches. However, with growing levels of GHGs, climate change and its consequences will continue to pose new challenges as well as mete out untold hardship on people. Currently, agriculture (and related sectors) contributes about a quarter of human-induced GHG emissions (IPCC 2007; FAO 2015), so it is highly necessary to reduce these emissions and other unfavorable effects from our environment. Many times, decreasing resource inputs and increasing efficacy goes hand in hand with mitigating emissions. If we can reduce the concentration of GHGs in our atmosphere, then extreme climate circumstances in the future would have been reduced considerably, and thus, it will be easier to adapt to climate change.

This chapter will therefore dwell on the interconnectedness of agriculture, climate change, and the effects of climate change on grain production. It will as well highlight grain farmers' coping and adaptation strategies to the impact of climate change.

---

## Focus Study Site

Kwara State is located in a hot and humid region with two major seasons; it has tropical wet and dry climate (Olanrewaju 2009), each lasting for about 6 months. Kwara State has an annual rainfall range of 1000–1500 mm from March until early September, although this is gradually shifting forward due to climate variations; while the dry season used to be from October to March. Again, this is also on the moving trend as temperature continues to be on the high side up until April/May. Temperature is uniformly high and ranges between 25 °C and 30 °C in the wet season; while the dry season ranges between 33 °C and 34 °C. On average, the state is occupied by subsistence tuber, legume, and cereal farmers who depend solely on rain-fed agriculture; hence one can only imagine how climate change would impact on these farmers. The major occupation of the people of Kwara is largely agricultural-related as more than 70% of the population are farmers. Moreover, the plain to slightly gentle topography of Kwara State further makes it favorable for agricultural growth while other climatic patterns, vegetation, and the fertile soil make the state suitable for the farming of an extensive range of food crops such as cereals, cowpea, cassava, and tree crops, such as cashew and mango (Olanrewaju 2012). This review adopted Kwara State as a focus site because there are large number of cereal farmers in addition to favorable soil condition for production of grains such as rice, maize, millet, and sorghum, as this can favor low consumption of nutrient, low managerial procedure, as well as two planting seasons for rice and maize among others.



## Agriculture and Cereal Production in Nigeria

Nigeria is an agrarian country with a reasonable percentage of its population engaging in agriculture at subsistence level (Adhvaryu et al. 2019). Like most countries in Sub-Saharan Africa (SSA), farmers in Nigeria not only live in rural areas, but their agricultural holdings are generally minute with about two-thirds of the total production being practiced with the use of simple methods and the bush-fallow system of cultivation. Agriculture, as practiced widely in Nigeria and other developing countries, is highly subjected to climate variability, and Nigeria's comprehensive range of climate differences supports a broad variety of the production of food crops (Olanrewaju 2012). Of the vast area of land for cultivation in Nigeria, cereals like sorghum, millet, rice, and corn are predominantly grown, but maize has overtaken the other traditional cereals such as wheat in terms of cultivation and popularity. Grains are rich in starches and contain substantial amounts of protein, as well as some fat and vitamins. They are essentially the world's staple food with over 70% of the world's harvested area producing a billion and a half tons of grains annually (Sokoto et al. 2016). Despite this, cereal production is set for a global increase with wheat, maize, and barley accounting for most of the rise in cereal production, while rice production is likely to maintain the increase as produced in 2018 (FAO 2019).

Rice is a starchy cereal that contains fiber, protein, vitamins, and minerals. It is consumed by more than half of the world's population (Rathna Priya et al. 2019) and is increasingly an important crop in Nigeria, with some species growing within 3 months. Africa cultivates about half of the 14 million metric tonnes of the annual global rice production (FAO 2019), while Nigeria is the largest producer and the leader in terms of consumption as well as importation in Africa. Nigeria's production has steadily advanced from two million metric tonnes to 8.0 million metric tonnes between 2008 through 2018 with the aim of reaching 18 million tonnes by 2023 (FAO 2019). This is due to rice policy reforms by the Federal Government of Nigeria who in its bid to eliminate rice importation enacted the anchor borrower's scheme that have paved way for proliferation of rice farming in the country (FAO 2019). Rice is not usually grown in isolation but with other crops such as sorghum, maize, and sweet potato. Initially, rice was noted as a luxurious food but has fast become a regular diet in every home in the country.

In Nigeria, maize is equally a significant food and feed crop which maintains an essential status for rural food security (Stevens and Madani 2016). Introduced to Nigeria in the sixteenth century, maize is the fourth most utilized cereal ranked below sorghum, millet, and rice (FAOSTAT 2014). Maize production in Nigeria is above ten million metric tons (Mundi Index 2018; FAO 2019), and it accounts for almost half of the calories and protein consumed in Eastern and Southern Africa (ESA), and one-fifth of the calories and protein consumed in West Africa. It is a significant source of carbohydrate, protein, iron, vitamin B, and minerals. Additionally, maize is essential in the cropping system of the small-scale Nigerian farmer and is frequently grown in mixture with other crops such as legumes or even cereals

under traditional practice. This is not only because maize is relatively more affordable than other cereal crops, but it is also widely accepted in the region as edible plant (Sowunmi and Akintola 2010). Apart from millet, maize is the earliest grain that is harvested in any given season in Nigeria, hence offering respite to the usual food scarcity being experienced at such periods of the year while maize consumption is generally acceptable in various forms across the country (Mundi Index 2018).

It is now a common knowledge that farming activities, including cereal production, has put global populations at vulnerable climatic situations and many studies have evolved in the area (Adger et al. 2004). In Nigeria, the vulnerability to climate change can be seen in the overwhelming effects of recent climatic catastrophes in all the six geopolitical zones of the nation. The protracted droughts resulting in increased temperatures as currently being observed in the northern region and the late arrival and early cessation of rain (Apata et al. 2009) are manifestations of climate change impact. It is evidently clear that Nigeria is highly susceptible to the effect of climate change because of its wide (800 km) coastline which is prone to sea level rise and the various challenges related to the violent storms (Apata et al. 2009). In view of the foregoing, it has become expedient to assess the various adaptation strategies adopted by cereal farmers in Nigeria in order to better cope with the effect of climate change as well as serve as knowledge bridging gap for other farmers to leverage on. The next sections would highlight the effect of climate change on cereal production before drawing conclusion and recommendations that cereal farmers in the region where Kwara State is located can derive ideas from.

---

## **The Impact of Climate Variability on Agriculture in Nigeria**

Climate variability may have an indirect influence on the goal of poverty alleviation in developing countries (Skoufias et al. 2011) as efforts at reducing the variations in climate help to increase agricultural yields which ultimately translate into better incomes for farmers and improved food security for the populace. This suggests that there might be efforts from development experts that could nurture linkages between climate vulnerabilities and development policies. Perhaps, such efforts and policy debates could eventually address the impact of climate change on agricultural-related practices. Falling incidences of climate variability will cushion the vulnerability levels of farmers (Skoufias et al. 2011), and the effect of climate change will normally be felt either directly or indirectly on all segments of the environment to include: socio-economy, water resources, food security, human health, ecosystems, coastal zones, and other related sectors. Fluctuations in precipitation and melting of glaciers are pointers to acute water shortages, soil erosion, and/or flooding (IPCC 2007), and these will absolutely affect agriculture produce. These climatic variations would inadvertently result in crop losses and low profits for farmers.

The steady increase in temperatures has necessitated an unavoidable shift in crop growing seasons for farmers in Nigeria and this has affected sufficient food availability and variations in the spread of disease vectors (Odjugo 2010;

Apata et al. 2009). The variations in climate amplifies vulnerability of people to diseases through the disease-carrying vectors. Moreover, upsurge in temperatures can possibly result in increased rates of extinction of many species and habitats. This, in itself, is not favorable for the ecosystem, and in a like manner, pest and diseases migrate in response to climate change with serious consequences on agriculture and the entire planet (IPCC 2007; Earth Journalism Network 2016). Such irregular temperature patterns and movements of pests lead to erratic rainfall and sunshine patterns, thereby resulting in crops' instability. It is therefore apparent that there is a heightened (above global mean) warming rate on the lands as evaporative cooling has greatly reduced, and there exists a smaller thermal inertia when compared to those found in the oceans. Boko et al. (2007) reported a similar scenario for Nigeria where the authors stated that the warming rate in Nigeria was above the mean rate for Africa.

Extreme rainfall patterns and variations in Nigeria have become a serious production risk for agricultural production system that is largely rain-fed (Olayide et al. 2016). The rain-fed agricultural production system is vulnerable to seasonal variability which affects the livelihood outcomes of farmers who greatly depend on this system of production. Previous studies have also shown that varying temperature fluctuations, heat waves, relative humidity, and rainfall are bound to compromise agricultural production as substantial losses are observed in the yield of grains such as rice, millet, sorghum, and maize in Nigeria (Sokoto et al. 2016). It was similarly found that maize along with other cereals were more susceptible to climate variability with untold consequence on the yield (Bismark and Richard 2019). Similarly, it was found that yields and productivity of maize, millet, sorghum, and rice were negatively affected by unfavorable climatic conditions such as drought, excessive temperature, and low rainfall (Bamiro et al. 2020).

The complications that are linked to climate change are not the same across the country. Nigeria, for example, has a tropical climate with two precipitation regimes spanning the north and south of the equator. The north is typically low in precipitation and high in temperature while parts of southwest and southeast are distinguishingly lower in temperatures with high amount of rainfalls (Nkechi et al. 2016; Akande et al. 2017). Obviously, the northern climate can lead to grave ecological effects as demonstrated by aridity, drought, and desert encroachment in the north, and flooding and erosion in the South (Nkechi et al. 2016; Akande et al. 2017). It was further shown through vulnerability analysis that States in the north, especially north east and north west region, experience higher degrees of vulnerability to climate change than those in the south (Federal Ministry of Environment 2014; Madu 2016). These variations in the northern climate are further compounded by desertification, loss of the wetlands, with a disturbing decrease in the volume of surface water, flora, and fauna resources on land (Abdulkadir et al. 2017; Ebele and Emodi 2016). Interestingly, the Southwest and Southeast are relatively less vulnerable when compared to other parts of the country because of the eco-friendlier climate patterns as depicted by high precipitation and relative humidity. Although, despite the relatively less vulnerability of the southern region of the country, the South-South (Niger Delta region) is most susceptible, due to sea level rise, increased

rainfall, coastal destruction, and flooding, which has resulted in the dislodgment of many settlements (Matemilola 2019).

The form of vulnerability to climate change usually corresponds with agronomic activities in a given location (Madu 2016). The argument here is that the northern regions of Nigeria, which coincidentally have higher degrees of rurality, are more vulnerable to climate change (Madu 2016). Hence, the adoption of existing and new technologies for adapting to climate change and variability is a high priority for most part of Nigeria. Evidence from secondary data has shown that farmers in the focus study site (Kwara State is located in the northern part of Nigeria) are already feeling the impact of climate change in many ways (Sokoto et al. 2016). The effect of climate change on cereals production is firstly noticeable in a sharp increase in production costs and reduced grains production while this translates into decreases in farmers' profit level (Sokoto et al. 2016). Ordinarily, the cost during production could have been minimal and relatively stable but for the heightened climate variabilities. In developing countries including Nigeria, climate variability and change do encourage heat and moisture stresses thereby adding to an already long list of existing problems (Earth Journalism Network 2016). How then are countries in the tropical regions able to deal with climate change impacts?

---

## **Climate Change Adaptation Strategies for Cereal Farmers in Nigeria**

Adaptation is a method through which people make themselves better able to cope with an uncertain future. Adapting to climate change will therefore entail the application of efficient actions to lessen the adverse effects of climate change (or exploit the positive ones) by making the necessary modifications in order not to greatly feel the negative impact. Emerging countries, such as Nigeria, typically perceives industrialized countries as climes with reduced vulnerability and better adaptation strategies given that such regions are better able to realize the prospects in cold weather episodes and hence make calculated moves to strengthen their agricultural production (Achike and Onoja 2014). The international community through the UNFCCC are in serious deliberations to find an effective means to battle climate change. It therefore becomes pertinent for the international community to entrench, in their future decisions, processes that will assist developing nations with transfer of knowledge, technology, and financial resources to adapt at all levels and in all sectors.

Recent study offered that farmers in Africa use crop diversification to build resilience in the agriculture sector (Mango et al. 2018), although this method may not be a favorable means among certain other farmers. However, adaptation, regardless of whatever form it takes, is already considered a major and important integral part of any future climate change regime. Some of the known technologies in use for climate change variability and impacts include: crop diversification, the adoption of drought-tolerant and early-maturing varieties of crops, and planting of cover crops (Federal Ministry of Environment 2014; Achike and Onoja 2014). Studies have

shown that farmers in Nigeria are being supported by government and other non-governmental organizations to better adapt to climate change using these, as well as other methods to deal with climate change impact (Ifeanyi-obi and Nnadi 2014). In addition, relevant weather-related information and skills training that can enhance productivity can be offered by agricultural extension services (Akintonde and Shuaib 2016). Although the current irregularity of extension services in Nigeria is a limitation to the adaptation strategies (Akintonde and Shuaib 2016).

Other adaptation strategies used by farmers in SSA including Nigeria are: early planting of crops, a condition where crops would have enjoyed some reasonable amount of rain before it ceases. Rainy season, of the current year, in certain parts of Nigeria experienced a somewhat climate change, and this means that Kwara State, along with many other states in the country, did not enjoy rains in the months of July and August; supposedly, those months should have been the peak of rains when activities for farmers would normally climax. Thus, some farmers who tapped into the opportunity of early planting sowed particular grains in May/June (maize for instance) when there were initial heavy rains and those farmers were able to survive the drought occasioned by the lack of rains. However, most grains that would normally be planted later in July did not survive as this coincided with the cessation of rains in July and August and farmers lost their resources (monies, inputs, time, and energy).

Improved variety is another adaptation strategy in use in order to cope with climate change impact. Farmers now plant improved varieties that have high resistance to pest and diseases, requires low water, matures quickly, and with many more qualities. This strategy was found to be popular among cereal farmers in Nigeria. For example, close observation of rice farmers in Kwara State showed that they employed similar means to combat the impact of climate change within the region. Farmers now plant a locally crossbred rice variety from Kebbi State that germinates in 12 weeks while some other farmers are yet to tap into this innovation and are still growing older rice varieties that reach maturity in 4 months and above. The improved rice variety offers farmers the opportunity to cultivate and harvest rice twice in one growing season especially if such farmer leveraged on early planting strategy. The snag here, however, is that the improved seeds are more expensive, although on the flipside, farmers can produce seeds for the next growing season from the current one and can consequently save some costs in the next planting season. Again, this method may not work if prolonged rain shortages are experienced and there are no facilities for irrigation.

Crop rotation is also one of the strategies used by the farmers to assuage the impact of climate change. Farmers in SSA including Nigeria do not restrict themselves to sowing a mono-crop. They use grains and/or legumes to rotate across seasons. A farmer might plant corn along with other tuber crops such as cassava in one season, and then proceed to corn and cowpea in another season. There are times when farmers are able to predict what the next planting season would look like given their experiences from previous climate variation patterns and based on local climatic indicators, although their predictions may not always work as projected. For instance, farmers may envisage a favorable climate in the next growing season if

temperatures in the current year are on the high and rains were too scanty. In such a situation, a farmer can predetermine which crops would offer more yield with high precipitation and less vulnerability to such weather. At the return of the rains in Kwara State at the tail end of August and beginning of September this year, farmers who have suitable lands hastened to plant soybean as this crop require less amount of rainfall and would normally germinate within 12 weeks when it is expected that the little rain that would fall in the remaining part of the season would be enough to see the crop to harvest in November. At some other times, farmers may rely on weather forecasts from relevant government agencies to determine what the forthcoming growing season would look like and adequately prepare for the crops that would thrive better in such weathers. Such information can also be leveraged on to determine what crops offer relative advantage over others, in order to make decisions as to the crops to rotate with the other in subsequent seasons. Such calculations help the farmers to plan better as well as make calculated risks that can translate to reduced climate change impacts.

In addition, farmers in Kwara State have also applied crop diversification as another adaptation strategy. For example, farmers have changed the crops grown on previously cultivated lands from a particular cereal crop to another due to climatic changes. Land that was previously being farmed for rice production because of abundance of water have now been converted to cultivation of maize and sorghum after such lands have lost their water content due to enduring droughts. The adaptation strategies adopted by cereal farmers in Kwara State are as seen in similar works where it was reported that crop diversification, adoption of drought-tolerant cultivars, early-maturing varieties of crops, and planting of cover crops are among the adaptation strategies being employed by farmers in Nigeria (Federal Ministry of Environment 2014; Achike and Onoja 2014).

Irrigation and drainage activities were also adaptive measures that farmers in Nigeria usually put into consideration during planting operations in order to secure water for plants during dearth periods (for example, as seen in northern Nigeria) and also mitigate the impact of flooding should the need arise, especially in the coastal southern region of Nigeria. This will reduce crop loss during insufficient and excessive rainfall like the full 2 months break earlier described in the current rainy season in Nigeria. Secondary data collected, observations and experiences from previous and current planting seasons showed that farmers in northern Nigeria had relied on strategies like direct interventions such as dike building to prevent flooding, large-scale relocation of farmers from excessively eroded areas, new crop selection, building of dams to expand irrigation, and crop rotation in order to curb the menace of climate change. Methods such as this would also ensure adequate yield of crops by farmers. Rice farmers in Kwara State, for instance, constructed make-shift dams at several points on their farms, where rain water is usually collected/deposited for use during dearth periods. Unfortunately, such water gets dried up whenever there is protracted or intense water shortage and farmers will sometimes need to walk long miles to areas where there are other sources of water (wells and boreholes) in order to irrigate their farms. The current prolonged lack of rains in Kwara State led to huge

losses as farmers were not hitherto prepared and consequently could not cope well with the situation.

Another adaptation strategy adopted by cereal farmers in the focal site is cultivation of more agricultural areas. By this, it was observed that farmers chose not to wait until harvest period before they will discover heavy crop losses and/or damages; hence they became proactive by cultivating large expanse of lands to increase their productivity. Some farmers have increased their farm sizes through cultivation of more lands as this will make them generate more income as well as improve their livelihood. Interestingly, majority of farmers in Kwara State, like other parts of the country, do not own the lands where they farm. First of all, all lands in the country belong to the government and anyone who intends to take possession would have to seek the owner's (government) permission in the form of "registration of title" which attracts special charges. However, farmers have usually cultivated lands without the owner's permission and they are always ready to move to other expanse of lands whenever the rightful owners emerge to take over the lands. Farmers have occasionally recorded huge losses when such circumstances arise but they would rather take such risks as it has almost become a norm among them. It is only the large-scale commercial farmers that normally acquire the lands rightfully. Meanwhile, while farmers may be increasing their yields by cultivating more expanse of lands, this method is indirectly expanding land used for agricultural activities and will consequently increase their risks and exposure to climate change impacts.

Livelihood diversification is also one strategy being used by cereal farmers in the focus site. Some farmers who feel they could no longer cope with the climate change impacts have decided to change the means/source of livelihood. Some of the cereal farmers in Kwara State have attempted diversification to nonfarming activities as adaptation strategies while discouraging youths, who are becoming more interested in white collar jobs, from participating in agricultural activities. Hence, though sadly, some of the farmers have boycotted farming for artisan jobs as well as bicycle riding jobs in order to sustain their families.

---

## Conclusion

Agricultural activities play a major role in the development of any country, and the effect of climate change on agronomic activities cannot be underrated due to its direct impact on agricultural production. Climate change may be a global issue but its effects will automatically differ between geographical regions. While food production in some areas may suffer from extreme weather and temperatures, farming in other regions might benefit from longer growing seasons and warmer climates. Early planting, crop diversification, planting of improved variety, irrigation and drainage practices, crop rotation activities, and cultivation of more agricultural land areas were the adopted strategies used in the focus site to help farmers cushion the impact of climate change. Therefore, farmers need to continue to adopt those strategies to combat this situation, in order to keep sustaining their livelihoods.

## Recommendations

Based on observations and inferences highlighted, cereal farming, in Nigeria as a whole and particularly in the area of focus, would be enhanced if these recommendations are taken:

1. There is a need for meteorological agencies (for example, Nigerian meteorological agency – NiMet) to widen their scope and expand their methodology to ensure that small-scale farmers benefit from their forecasts, in order to reduce farm losses due to unfavorable weather episodes. This will make farmers to predetermine the crops and time to plant.
2. Rain-water collection systems can be made available by collaborative efforts of the farmers, while government and other stakeholders serve as buffer during dry season and early cessation of rainfall. This will help in situations like the one experienced this current season by farmers in Kwara State where farmers became helpless as a result of unexpected shortage of rains.
3. The public sector (government) can further encourage small-scale farmers by instituting favorable policies that will stimulate farmers to remain on the fields as well as enhance them to better cope with unfavorable climatic conditions. Such policies, like fertilizer subsidy and those enacted for increased rice production, would reduce cases of livelihood diversification where youths are seen to migrate to cities for alternative jobs.
4. Provision of communal irrigation facilities (every problem must not be solved at the instance of government) for use in times of water scarcity to avoid food shortages for the populace. This will also reassure farmers that their efforts would not be a waste and the fear of unexpected huge losses on their part can be allayed.

---

## References

- Abdulkadir A, Lawal MA, Muhammad TI (2017) Climate change and its implications on human existence in Nigeria: a review. *Bayero J Pure Appl Sci* 10(2):152–158. <https://www.ajol.info/index.php/bajopas/article/viewFile/170772/160195>
- Achike AI, Onoja AO (2014) Greenhouse gas emission determinants in Nigeria: implications for trade, climate change mitigation and adaptation policies. <https://www.journalijecc.com/index.php/IJECC/article/view/27273/51196>
- Adger WN, Brooks N, Bentham G, Agnew M, Eriksen S (2004) New indicators of vulnerability and adaptive capacity. Tyndall centre technical report, no 7. Tyndall Centre for Climate Change Research, University of East Anglia, Norwich
- Adhvaryu A, Nyshadham A, Tamayo J (2019) Managerial quality and productivity dynamics. Harvard Business School. Working paper 19–100
- Ajadi BS, Adeniyi A, Afolabi MT (2011) Impact of climate on urban agriculture: case study of Ilorin City, Nigeria. *Global J Human Soc Sci* 11(1)., Type: Double Blind Peer Reviewed International Research Journal Publisher: Global Journals Inc. (USA)
- Akande A, Costa AC, Mateu J, Henriques R (2017) Geospatial analysis of extreme weather events in Nigeria (1985–2015) using self-organizing maps. *Adv Meteorol*. <https://doi.org/10.1155/2017/8576150>
- Akintonde JO, Shuaib L (2016) Assessment of level of use of climate change adaptation strategies among arable crop farmers in Oyo and Ekiti States, Nigeria. *J Earth Sci Clim Chang* 7:369.



- <https://www.omicsonline.org/open-access/assessment-of-evel-of-se-of-climate-change-adaptation-strategiesamong-arable-crop-farmers-in-oyo-and-ekiti-states-nigeria-2157-7617-1000369.php?aid=80244>
- Apata TG, Samuel KD, Adeola AO (2009) "Analysis of climate change perception and adaptation among arable food crop, farmer in South Western Nigeria" Contributed paper at the International Association of Agricultural Economists 2009 conference, Beijing
- Bamiro O, Adeyonu A, Ajiboye B, Solaja S, Sanni SO, Faronbi O, Awe T (2020) Effects of climate change on grain productivity in Nigeria (1970–2014). IOP conference series. Earth Environ Sci 445:012058. <https://doi.org/10.1088/1755-1315/445/1/012058>
- Bismark MB, Richard K (2019) Climate Variability Effect on Food Crop Yield among the Smallholder Farmers in Lower Off in River Basin, Ghana. Journal of Agriculture and Environmental Sciences 8(2):66–74. Published by American Research Institute for Policy Development. <https://doi.org/10.15640/jaes.v8n2a9>
- Boko M, Niang I, Nyong A, Vogel C, Githeko A, Medany M, Osman-Elasha B, Tabo R, Yanda P (2007) In: Parry ML, Canziani OF, Palutikof JP, van der Linden PJ, Hanson CE (eds) Africa climate change: impacts, adaptation and vulnerability. Contribution of working group II to the fourth assessment report of the intergovernmental panel on climate change. Cambridge University Press, Cambridge, UK, pp 433–467
- Earth Journalism Network (2016) Introduction to climate change. Available at: <https://earthjournalism.net/resources/introduction-to-climate-change>
- Ebele NE, Emodi NV (2016) Climate change and its impact in Nigerian economy. J Sci Res Rep 10(6):1–13. <http://www.journaljsrr.com/index.php/JSRR/article/view/21917/40737>
- FAO (2015) Climate change and food systems: global assessments for food security and trade. In: Elbehri A (ed) A publication of the Food and Agricultural Organization, Rome. Available at: <http://www.fao.org/3/a-i4332e.pdf>
- FAO (2019) Food outlook – biannual report on global food markets. Rome. Licence: CC BY-NC-SA 3.0 IGO
- FAOSTAT (2014) The state of food and Agriculture, investing in Agriculture for a better future. <http://Faostat.fao.org>
- Federal Ministry of Environment (2014) United nations climate change Nigeria. National Communication (NC). NC 2. 2014. <https://unfccc.int/sites/default/files/resource/nganc2.pdf>
- Ifeanyi-obi CC, Nnadi FN (2014) Climate change adaptation measures used by farmers in south-South Nigeria. J Environ Sci Toxicol Food Technol 8(4). <https://pdfs.semanticscholar.org/a63d/22bf8b8ebde892a7c9d761ee1653e0e11df6.pdf>
- IPCC (2007) Climate change 2007: impacts adaptation and vulnerability. In: Contributions of working group II to the fourth assessment report of the intergovernmental panel on climate change. Cambridge University Press, Cambridge, UK
- Madu IA (2016) Rurality and climate change vulnerability in Nigeria: assessment towards evidence based even rural development policy. Paper presented at the 2016 Berlin conference on global environmental change, 23–24 May 2016 at Freie Universität Berlin. [https://pdfs.semanticscholar.org/508b/94cab07b84a703b44eca1089326cc98d7495.pdf?\\_ga=2.154518008.112403230.1572433568-162569160.1557482164](https://pdfs.semanticscholar.org/508b/94cab07b84a703b44eca1089326cc98d7495.pdf?_ga=2.154518008.112403230.1572433568-162569160.1557482164)
- Mango N, Makate C, Mapemba L et al (2018) The role of crop diversification in improving household food security in central Malawi. Agric Food Sec 7:7. <https://doi.org/10.1186/s40066-018-0160-x>
- Matemilola S (2019) Mainstreaming climate change into the EIA processing Nigeria: perspectives from projects in the Niger Delta region. Climate 7(2):29. <https://doi.org/10.3390/cli7020029>
- Mboera L, Mayala B, Kweka E, Mazigo H (2012) Impact of climate change on human health and health systems in Tanzania: a review. Tanzan J Health Res 13. <https://doi.org/10.4314/thrb.v13i5.10>
- Mundi Index (2018) Nigeria country profile. Available at: [https://www.indexmundi.com/nigeria/agriculture\\_products.html](https://www.indexmundi.com/nigeria/agriculture_products.html)
- Nkechi G, Onah N, Ali A, Eze E (2016) Mitigating climate change in Nigeria: African traditional religious values in focus. Mediter J Soc Sci 7(6):299–308. <https://www.mcser.org/journal/index.php/mjss/article/view/9612>

- Odjugo PAO (2010) Adaptation to climate change in the agricultural sector in the semi-arid region of Nigeria. Paper presented at the 2nd international conference: climate, sustainability and development in semi-arid regions, Fortaleza-Ceará, Brazil, August 16–20, 2010
- Olanrewaju RM (2009) Climate and the growth cycle of yam Plant in the Guinea Savannah Ecological Zone of Kwara state, Nigeria. *J Meteorol Clim Sci*:43–48
- Olanrewaju RM (2012) Effect of climate on yam production in Kwara State, Nigeria. *Environmental Issues*, Department of Geography and Environmental Management, University of Ilorin, Ilorin 3(1):30–34
- Olayide OE, Kow Tetteh I, Popoola L (2016) Differential impacts of rainfall and irrigation on agricultural production in Nigeria: any lessons for climate-smart agriculture? *Agric Water Manag* 178:30–36. <https://doi.org/10.1016/j.agwat.2016.08.034>. ISSN 0378-3774. Available: <http://www.sciencedirect.com/science/article/pii/S0378377416303286>
- Omumbo JA, Lyon B, Waweru SM, Connor SJ, Thomson MC (2011) Raised temperatures over Kericho tea estates: revisiting the climate in the east African highlands malaria debate. *Malar J* 10:2
- Rathna Priya T, Eliazer Nelson ARL, Ravichandran K (2019) Nutritional and functional properties of coloured rice varieties of South India: a review. *J Ethn Food* 6:11. <https://doi.org/10.1186/s42779-019-0017-3>
- Reuben J, Barau AD (2012) Resource use efficiency in yam production in Taraba state, Nigeria, *journal of agricultural science. Kamla-Raj* 3(2):71–77
- Skoufias E, Vinha K, Conroy HV (2011) The impacts of climate variability on welfare in rural Mexico, policy research working paper 5555. World Bank, Washington, DC
- Sokoto M, Tanko L, Abubakar L, Dikko A, Abdullahi Y (2016) Effect of climate variables on major cereal crops production in Sokoto state, Nigeria. *Am J Exp Agric* 10:1–7. <https://doi.org/10.9734/AJEA/2016/20020>
- Sowunmi FA, Akintola JO (2010) Effect of climatic variability on maize production in Nigeria. *Res J Environ Earth Sci* 1:19–30
- Stevens T, Madani K (2016) Future climate impacts on maize farming and food security in Malawi. *Sci Rep* 6:36241
- Zoellick RB (2009) *A climate smart future, the nation newspapers*. Vintage Press Limited, Lagos, p 18

**Open Access** This chapter is licensed under the terms of the Creative Commons Attribution 4.0 International License (<http://creativecommons.org/licenses/by/4.0/>), which permits use, sharing, adaptation, distribution and reproduction in any medium or format, as long as you give appropriate credit to the original author(s) and the source, provide a link to the Creative Commons license and indicate if changes were made.

The images or other third party material in this chapter are included in the chapter's Creative Commons license, unless indicated otherwise in a credit line to the material. If material is not included in the chapter's Creative Commons license and your intended use is not permitted by statutory regulation or exceeds the permitted use, you will need to obtain permission directly from the copyright holder.





# Dual Pathway Model of Responses Between Climate Change and Livestock Production **29**

Adetunji Oroye Iyiola-Tunji, James Ijampy Adamu,  
Paul Apagu John, and Idris Muniru

## Contents

Introduction .....	525
Climate Projection .....	527
Climate of Nigeria .....	527
Materials and Methods .....	528
Survey of Livestock Stakeholders .....	528
Climate Data and Analysis .....	529
Standardized Precipitation Index and Trend Analysis .....	530
Temperature Humidity Index .....	531
Results and Discussion .....	531
Rainfall Trend/Patterns in Nigeria from 1982 to 2019 .....	531
Comparison of Variations in Climatic Elements Among Sahel, Sudan, and Northern Guinea Savannah Zones .....	531
Precipitation .....	531
Rainfall Trend/Patterns in Guinea Savannah of Nigeria .....	533

This chapter was previously published non-open access with exclusive rights reserved by the Publisher. It has been changed retrospectively to open access under a CC BY 4.0 license and the copyright holder is “The Author(s)”. For further details, please see the license information at the end of the chapter.

A. O. Iyiola-Tunji (✉)

National Agricultural Extension and Research Liaison Services, Ahmadu Bello University, Zaria, Nigeria

e-mail: [tunjiyiola@naerls.gov.ng](mailto:tunjiyiola@naerls.gov.ng)

J. I. Adamu

Nigerian Meteorological Agency, Abuja, Nigeria

P. A. John

Department of Animal Science, Ahmadu Bello University, Zaria, Nigeria

I. Muniru

Department of Biomedical Engineering, Faculty of Engineering and Technology, University of Ilorin, Ilorin, Nigeria

e-mail: [muniru.oi@unilorin.edu.ng](mailto:muniru.oi@unilorin.edu.ng)

© The Author(s) 2021

W. Leal Filho et al. (eds.), *African Handbook of Climate Change Adaptation*,  
[https://doi.org/10.1007/978-3-030-45106-6\\_230](https://doi.org/10.1007/978-3-030-45106-6_230)

523

Relative Humidity .....	534
Atmospheric Temperature .....	534
The Concept of Temperature Humidity Index .....	535
Livestock Production Characteristics in Sahel, Sudan, and Guinea Savannah Zones of Nigeria .....	536
Livestock Population in Nigeria .....	540
Adaptive Measures Against the Effect of Climate Change on Livestock Production .....	545
Contribution of Livestock Production Activities Toward Climate Change .....	547
Adaptive Measures Toward Mitigation of Effect of Climate Change on Livestock .....	550
Pathway of Responses .....	553
Predicting Climatic Conditions Using Machine Learning Approach .....	555
Conclusion and Recommendations .....	557
References .....	557

## Abstract

This chapter was aimed at evaluating the responses of livestock to fluctuations in climate and the debilitating effect of livestock production on the environment. Survey of livestock stakeholders (farmers, researchers, marketers, and traders) was carried out in Sahel, Sudan, Northern Guinea Savannah, Southern Guinea Savannah, and Derived Savannah zones of Nigeria. In total, 362 respondents were interviewed between April and June 2020. The distribution of the respondents was 22 in Sahel, 57 in Sudan, 61 in Northern Guinea Savannah, 80 in Southern Guinea Savannah, and 106 in Derived Savannah. The respondents were purposively interviewed based on their engagement in livestock production, research or trading activities. Thirty-eight years' climate data from 1982 to 2019 were obtained from Nigerian Metrological Agency, Abuja. Ilela, Kiyawa, and Sabon Gari were chosen to represent Sahel, Sudan, and Northern Guinea Savannah zone of Nigeria, respectively. The data contained precipitation, relative humidity, and minimum and maximum temperature. The temperature humidity index (THI) was calculated using the formula:  $THI = 0.8 * T + RH * (T - 14.4) + 46.4$ , where T = ambient or dry-bulb temperature in °C and RH=relative humidity expressed as a proportion. Three Machine Learning model were built to predict the monthly minimum temperature, maximum temperature, and relative humidity respectively based on information from the previous 11 months. The methodology adopted is to treat each prediction task as a supervised learning problem. This involves transforming the time series data into a feature-target dataset using autoregressive (AR) technique. The major component of the activities of livestock that was known to cause injury to the environment as depicted in this chapter was the production of greenhouse gases. From the respondents in this chapter, some adaptive measures were stated as having controlling and mitigating effect at reducing the effect of activities of livestock on the climate and the environment. The environment and climate on the other side of the dual pathway is also known to induce stress on livestock. The concept of crop-livestock integration system is advocated in this chapter as beneficial to livestock and environment in the short and long run. Based on the predictive model developed for temperature and relative humidity in a sample location (Ilela) using Machine

Learning in this chapter, there is need for development of a web or standalone application that will be useable by Nigerian farmers, meteorological agencies, and extension organizations as climate fluctuation early warning system. Development of this predictive model needs to be expanded and made functional.

---

**Keywords**

Savannah · *Sudano-Sahel* · Climate change · Adaptation Livestock · Nigeria

---

**Introduction**

Livestock is important as sources of food (FAO 1993; Murphy and Allen 2003), fiber (Iyiola-Tunji 2012), and farm power (Srivastava 2006; Umar et al. 2013) in most part of sub-Saharan Africa. Adesogan et al. (2020) elaborated on the fact that the almost 800 million people who live in poverty (living on less than \$1.90 per day) and subsist on a diet heavily based on starchy foods. They elaborated that animal source food will be required for millions more people who are slightly better off in terms of their incomes because animal source food provide not only calories but, more importantly, the nutrients required for achievement of human development potential. The dependability of some livestock keepers transcends the basic uses of the products and by-products of livestock to their uses as a form of savings for the raining days. Schmidt (2008) argued in favor of wealth storage in the form of cattle as a rational investment decision. Bettencourt et al. (2015) presented livestock feature as living savings which can be converted into cash whenever its needed, as well as a security asset influencing access to informal credits and loans and being also a source of collateral for loans.

It is expected that as the population of humans is increasing, the demands for animal products will also be increasing (FAO 2011). However, the production environments from which most of our animals are coming from in Africa are not improving commensurately to the potential demands for the stocks. The breeds of animals that are indigenous to specific locations in Africa have the advantages of adaptability to the environment from which they have lived for several hundreds of years. The environments to which these animals are adapted are heavily laden with stress. This in turn leads to low productivities. Heat stress is an intriguing factor that negatively influences livestock production and reproduction performances (Berihulay et al. 2019).

The dynamics of the environment in sub-Saharan Africa is widely varied within and between regions. In Nigeria, there are humid forest in the South and different categories of Savannah Northward. According to Abdulkadir et al. (2015), the potential impact of climate change, rainfall variability patterns and the dynamic hydrologic regimes have continued to escalate land degradation and make it imperative that the broad ecoclimatic zones could have changed. Variability of climate elements can also predispose animals to diseases. The distribution and incidence of animal diseases, specifically vector borne disease, are directly influenced by climate

because the geographical distributions of vectors are predetermined by temperature and humidity (Kebede et al. 2018). Livestock production is being adversely affected by detrimental effects of extreme climatic conditions. Consequently, adaptation and mitigation of detrimental effects of extreme climates have played a major role in combating the climatic impact in livestock production (Khalifa 2003).

The level of aridity increases northward in the country. Haider (2019) reported on the challenges associated with climate change in Nigeria which are not the same across the country. The low precipitation in the North and high precipitation in parts of the South were reported to have led to aridity, drought, and desertification in the North and erosion due to flooding in the South (Onah et al. 2016; Akande et al. 2017). The more arid zones are the regions with the most population of livestock like cattle, sheep, and goats. Animals like camel and donkeys are exclusively found in the most arid regions of the country also. Over the years there had been reported cases of extreme high temperatures, drought, flooding, and some other climate-induced stressors. These phenomena always result in losses in productivity of the animals and accruable incomes to the farmers. So, in combating these problems, farmers (especially pastoralists) had adopted migration southward with their animals during the dry season when feed resources and water are not readily available. Some more adaptive measures along with the seasonal migration of stocks were evaluated in this chapter.

Apart from the effect of climate change on livestock which had been studied extensively, animals on higher production levels tend to be more sensitive to high temperature and humidity (Hahn 1989; Aydinalp and Cresser 2008; Nwosu and Ogbu 2011), there is also need for the understanding of the effect of livestock production activities that are capable of causing changes in climatic elements. Based on the submission of Brown (2019) and FAO report (<http://www.fao.org/news/story/en/item/197623/icode/>), rearing livestock generates 14.5% of global greenhouse gas emissions that are very bad for the environment. Livestock and their by-products account for million tons of carbon dioxide per year (Flachowsky and Kamphues 2012). Extensive system of livestock production plays a critical role in land degradation, climate change, water, and biodiversity loss. The problems surrounding livestock production cannot be considered in isolation. Economic, social, health, and environmental perspectives will be critical to solving some of these problems. There is need for development of a greater understanding of these complex issues so that we may encourage policies and practices to reduce the adverse effects of livestock production on climate, while ensuring that humans are fed and natural resources are preserved. A Human Society International report advocated that mitigating the animal agriculture sector's significant yet underappreciated role in climate change is vital for the health and sustainability of the planet, the environment, and its human and non-human inhabitants. Reducing greenhouse gasses (GHG) emissions, especially from animal agriculture is both urgent and critical (<https://www.humanesociety.org/sites/default/files/docs/hsus-report-agriculture-global-warming-and-climate-change.pdf>). This chapter however was aimed at evaluating the observed effects of fluctuation of climatic elements on livestock production and vice versa.

---

## Climate Projection

The climate of the future is not clear due to how factors such as socioeconomics, technology, land use, and emissions of greenhouse gases will change and unfold (van Vuuren et al. 2011). A climate change scenario represents a specific possible future climate with for example high amounts of green technology contra a scenario with low amount of green technology. The dominant climate change scenarios are the representative concentration pathways (RCP) family of climate change scenarios. There exist mainly four RCP scenarios which are the RCP2.6, 4.5, 6, and 8.5. The two latter numbers indicate the radiative forcing target level for the year 2100 given a specific timeline, where the radiative forcing is the net change in the energy balance of the earth system due to some forcing agent expressed in watt per square meters ( $W/m^2$ ) (Myhre et al. 2013; van Vuuren et al. 2011). These radiative forcers can be anthropogenic or natural, which can be greenhouse gas emissions or volcanic eruptions, respectively (Myhre et al. 2013).

The RCP2.6 trajectory signifies immediate anthropogenic intervention with strong climate change mitigation (van Vuuren et al. 2011). The RCP4.5 trajectory signifies stabilization of greenhouse gas emissions which like the RCP2.6 is also a scenario containing anthropogenic climate change mitigation but as prolific (Thomson et al. 2011). The RCP6 trajectory is similar to RCP4.5 but where climate change mitigation policies and technology implementations are not as strong (van Vuuren et al. 2011). The RCP8.5 trajectory signifies what is called as the “business as usual” trajectory with an increase in population, slow socioeconomic development, and slow innovation/implementation of technology (Riahi et al. 2011).

A core concept in the discussions around climate change is that of “adaptive capacity” or the potential of a society to adapt with the changes (if any) that might occur in the social ecological system from climate change (IPCC 2007a, b; McClanahan et al. 2008). Changes in climate have the potential to affect the agricultural industry which in turn can affect economic investment and population movements in countries. The livelihoods of many people, notably the poor and vulnerable, could be threatened if government and resource managers are not prepared for even the modest changes associated with climate change (Downing et al. 1997).

---

## Climate of Nigeria

The climate of Nigeria is dominated by the influence of three main wind currents: the Tropical Maritime (TM) air mass, the Tropical Continental (TC) air mass, and the Equatorial Easterlies (EE) (Ojo 1977). The TM and TC air masses meet along the Inter-Tropical Discontinuity (ITD), which is a key driver of Nigeria’s climate. The position of the ITD and oscillation during the year affects the spatial and temporal distribution of key climate characteristics of the country (Adegoke and Lamptey 1999). Following the annual movement of the ITD across the Equator, the rainfall season over Nigeria advances from the coast to the inland areas from March to

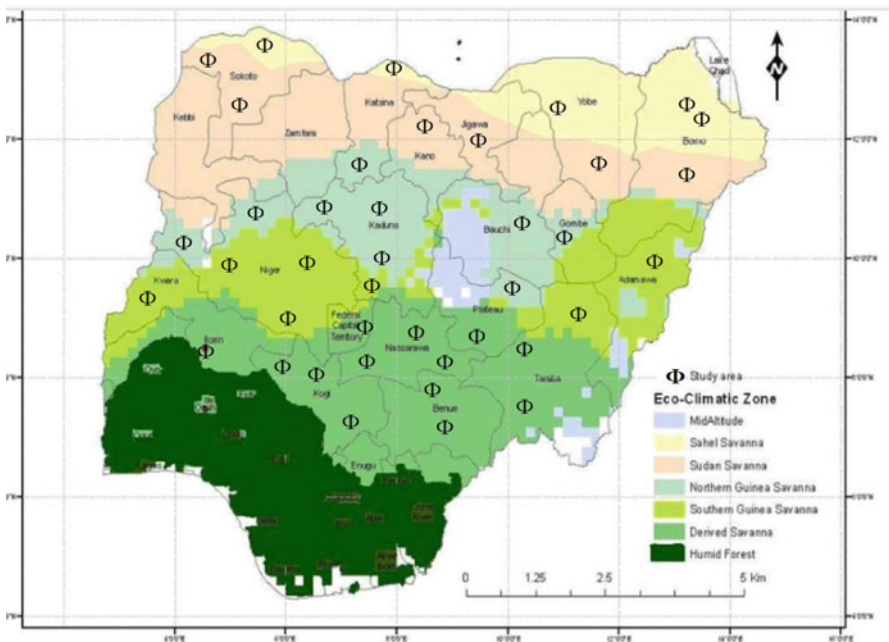
August and retreats from September to November, with a pronounced dry period between December and February. The rainfall patterns in Nigeria show the southern parts of the country with annual rainfall over 3000 mm and semiarid conditions in the north with annual rainfall less than 500 mm.

## Materials and Methods

### Survey of Livestock Stakeholders

A survey of livestock stakeholders (farmers, researchers, marketers and traders) was carried out in Sahel, Sudan, Northern Guinea Savannah, Southern Guinea Savannah, and Derived Savannah zones of Nigeria (Fig. 1). The regions under these ecoclimatic zones cut across all the 19 States and the Federal Capital Territory (FCT) of Nigeria. In total, 362 respondents were interviewed between April and June 2020. The survey instrument used was designed as an online questionnaire (for literate respondents). The other respondents who cannot fill the online form were administered printed questionnaire for the survey.

The distribution of the respondents was 22 in Sahel, 57 in Sudan, 61 in Northern Guinea Savannah, 80 in Southern Guinea Savannah, and 106 in Derived Savannah (Table 2). The respondents were purposively interviewed based on their engagement in livestock production, research or trading activities. The researchers were sourced



**Fig. 1** Ecoclimate zones of Nigeria showing the study areas



**Table 2** Production characteristics of livestock stakeholders in Savannah and Sudano-Sahelian zones of Nigeria ( $N = 326$ )

	Frequency	Percent (%)
<b>Primary occupation of stakeholders</b>		
Livestock farmers	203	62.3
Research scientist	92	28.2
Livestock marketer or trader	31	9.5
<b>Type of animals being reared by respondents</b>		
Cattle	99	30.4
Sheep	117	35.9
Goat	125	38.3
Donkey	5	1.5
Camel	12	3.7
Micro-livestock	72	22.1
Poultry	144	44.2
<b>Preferred management system as indicated by respondents</b>		
Intensive	163	50.0
Semi-intensive	133	40.8
Extensive	30	9.2
<b>Distribution of respondents according to climate zones</b>		
Sahel	22	6.7
Sudan	57	17.5
Northern Guinea Savannah	61	18.7
Southern Guinea Savannah	80	24.5
Derived Savannah	106	32.5
<b>Awareness of the concept of climate change</b>		
Yes	300	92.0
No	13	4.0
Maybe	13	4.0

$N$  is the number of respondents

through their institutional affiliations. The farmers and marketers were sourced through the Agricultural Development Programs and Ministry of Agriculture (or Livestock) of the 19 States in the Northern regions of Nigeria as well as FCT. Key informant interview was conducted with Alhaji Ibrahim Mohammed – Director, FADAMA and Infrastructural Development of Yobe State Agricultural Development Program, Yobe State. The primary data obtained from this work were analyzed using frequency counts and percentages through crosstab analysis of Statistical Package for Social Sciences (SPSS) Version 16.

## Climate Data and Analysis

Representative locations were chosen for Sahel, Sudan, and Northern Guinea Savannah. Ilela, Kiyawa, and Sabon Gari were chosen to represent Sahel, Sudan, and northern Guinea Savannah zone of Nigeria, respectively. Thirty-eight years'

climate data from 1982 to 2019 were obtained from Nigerian Metrological Agency, Abuja. The data contained precipitation, relative humidity, and minimum and maximum temperature. This chapter employed the use of grid data obtained from the US National Oceanic and Atmospheric Authority (NOAA) reanalyzed historic data and complimented with Soil and Water Assessment Tool (SWAT) data. The major climatic parameters used in this chapter are rainfall, relative humidity, and temperature. To understand the nature of rainfall variation and trend and to determine climate extremes, data from 1982 to 2019 (38 years) for all weather stations within the study area were used. Descriptive statistical methods such as mean and standard deviation were utilized. Furthermore, time series was used for the analysis of rainfall trend over time, and the Moving Average Technique was also used in the analyses of the data. This chapter employed the use of the 3-Year Moving Average. The moving average has the characteristics of reducing the amount of variation in a set of data. This property in the time series is used mostly to remove fluctuations that are not needed. The use of moving average resulted in the formation of new series in which each of the actual value of the original series is replaced by the mean of itself and some of the values immediately preceding it and directly following it Ayoade (2008). To estimate the value of a variable Y (i.e., rainfall), corresponding to a given value of a variable X (i.e., time), regression analysis was applied. This was accomplished by estimating the value of Y from a least-squares curve that fits the sample data.

## Standardized Precipitation Index and Trend Analysis

The Standardized Precipitation Index (SPI) calculation used was based on the long-term precipitation record for the desired period. This long-term record is fitted to a probability distribution, which is then transformed into a normal distribution so that the mean SPI for the location and desired period is zero (Edwards and McKee 1997). Positive SPI values indicate greater than median precipitation, and negative values indicate less than median precipitation. Because the SPI is normalized, wetter and drier climates can be represented in the same way, and wet periods can also be monitored using the SPI.

A correlation was done to determine how well a linear equation describes or explains the relationship between variables. From this analysis, the coefficient of determination was obtained, this is given by  $R^2$ . The standardized precipitation values were calculated for all the years from the use of the long-term mean, yearly mean, and the standard deviation using the equation below:

$$\varphi = \frac{X - \bar{X}}{\sigma}$$

where  $\varphi$  represents the standardized departure,  $x$  is the actual value of the parameter (annual rainfall),  $\bar{x}$  is the long term mean value of parameter (30 years rainfall average), and  $\sigma$  is the standard deviation.

Confidence test was performed on the dataset used and it was verified using 95% confidence interval. Coefficients of skewness, kurtosis, and variation were also investigated.

## Temperature Humidity Index

The temperature humidity index (THI) was calculated using the following formula:

$$\text{THI} = 0.8 * T + \text{RH} * (T - 14.4) + 46.4$$

where T = ambient or dry-bulb temperature in °C and RH=relative humidity expressed as a proportion, that is, 75% humidity is expressed as 0.75.

---

## Results and Discussion

### Rainfall Trend/Patterns in Nigeria from 1982 to 2019

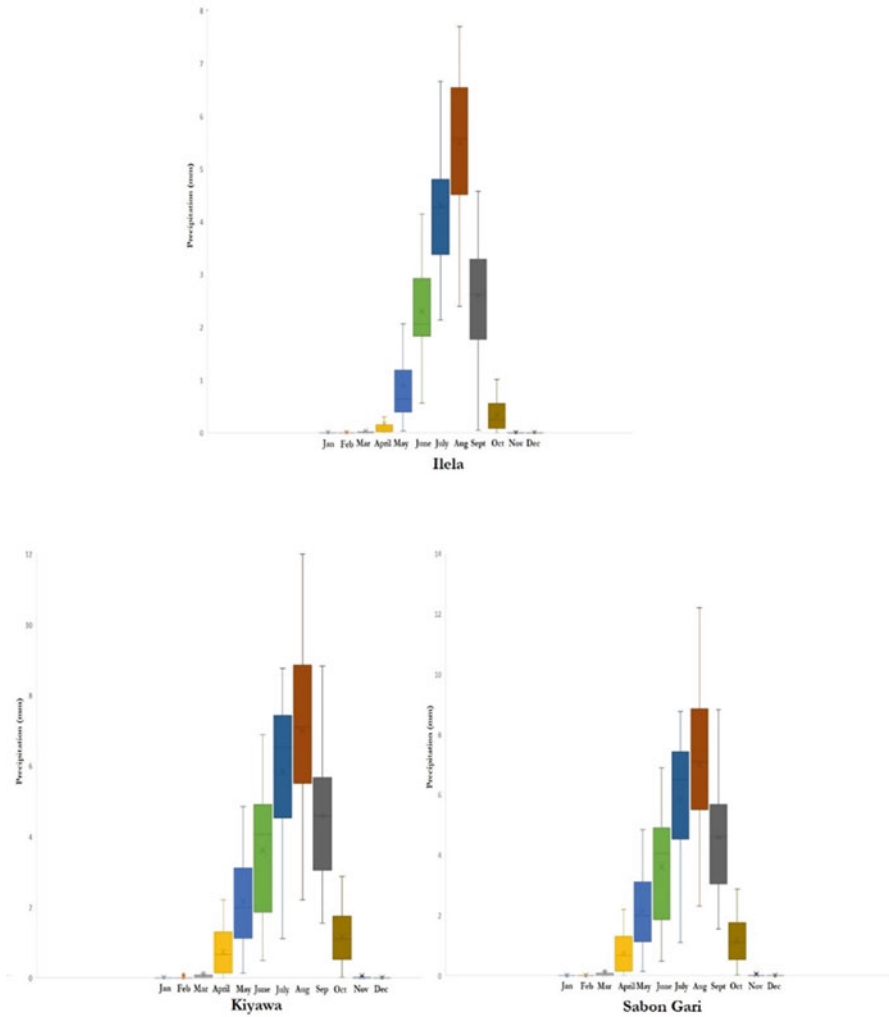
The analysis shows the standardized rainfall anomaly over different climatic zones in Nigeria from 1982 to 2019. In the coastal, tropical rainforest, guinea, Sudan savannah areas, it was observed that there are more wet years than dry years. But for the Sahel savannah, the dry years were more than the wet years during the 48 years study period. The result corresponds to IPCC projection stating that the coastal areas are prone to more wet years leading to the occurrence of flooding and rainfall induced erosion, while region around the Sahel will experience more of drought as a result of reduction in the total precipitation.

---

### Comparison of Variations in Climatic Elements Among Sahel, Sudan, and Northern Guinea Savannah Zones

#### Precipitation

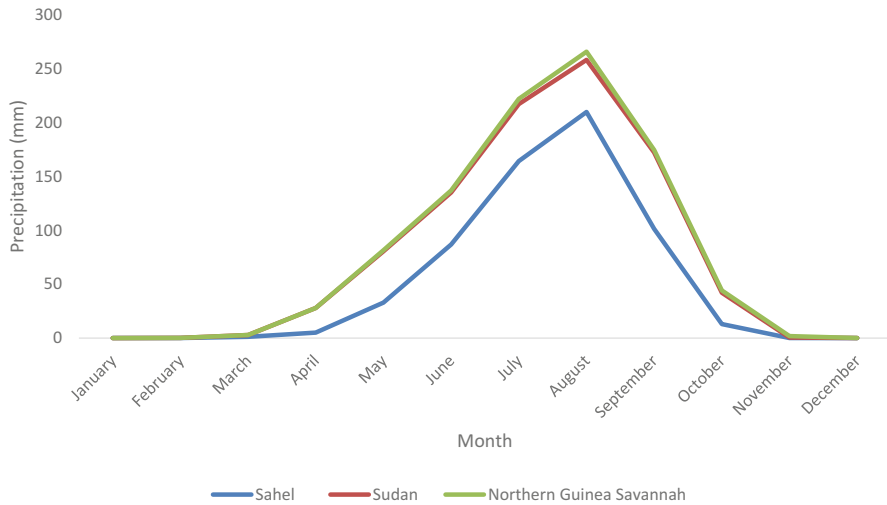
Figure 2 showed the weighted average precipitation for Sahel, Sudan, and Northern Guinea Savannah zones of Nigeria. Ilela in Sokoto State was used as a reference point for Sahel while Kiyawa, Jigawa State and Sabon Gari, Kaduna State were used as reference points for Sudan and Northern Guinea Savannah zones, respectively. The number of months with substantial period of precipitation was seven from April to October at Ilela (Sahel). The maximum precipitation (7.86 mm) was recorded in July. Similar trends of duration of precipitation were also observed at Kiyawa and Sabon Gari. However, the maximum amount of precipitation was 11.97 and 12.31 mm, respectively, for Kiyawa and Sabon Gari. Figure 3 showed the average total precipitation (mm) for Sahel, Sudan, and Northern Guinea Savannah zones of



**Fig. 2** Weighted average precipitation for Sahel, Sudan, and Northern Guinea Savannah zones of Nigeria for 1982 to 2019

Nigeria from 1982 to 2019. The average total volume of precipitations within the 38 years for the three zones were 614.79, 937.32, and 958.58 mm, respectively, for the Sahel, Sudan, and Northern Guinea Savannah zones. The volume of precipitation for Sudan and Northern Guinea Savannah were almost similar for most periods of the year except for July, August, and September when the volumes of rainfall was higher in Northern Guinea Savannah zones of Nigeria. The onset and end of rainfall in the two regions were similar.

Analyses of Standardized Precipitation Index (SPI) over the Sahel Savannah of Nigeria are presented in Fig. 5. The figure showed that in the first decade (1971–1980) and the second decade (1981–1990) the whole region had mostly



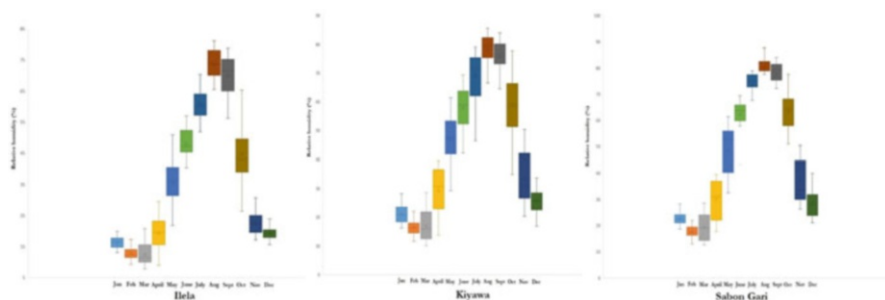
**Fig. 3** Average total precipitation (mm) for Sahel, Sudan, and Northern Guinea Savannah zones of Nigeria for 1982 to 2019

negative anomalies. This indicates the zone suffered from serious hydrological drought from 1971 to 1990. However, there was a recovery to positive anomalies in the third decade (1991–2000), fourth decade (2001–2010), and the current decade (2011–2018). The dry years were more than the wet years during the 48 years study period. The result shows the region recorded 27 dry years and 19 wet years which corresponds to IPCC (2007a) projection stating that the Sahel will experience more of drought as a result of reduction in the total precipitation. With the predominant dry years in the region, water erosion should not have been a problem. Areas affected by water erosion challenges in the region indicates the little rainfall amount recorded occurred at very short interval with high intensity thereby generating runoff. This rainfall pattern is typical under a changing climate.

The analysis shows rainfall trend over Sahel Savannah of Nigeria for 1982–2019 as shown in Fig. 1. From 1981 to 1997 rainfall was increasing and decreasing in cycle of 4–5 years, though the cycle was in a declining rainfall order. During the first decade (1982–1990), the pattern showed decreasing rainfall amount. The second decade (1991–2000) up to 2018 showed a steady increase in rainfall amount a little above the average for region. This trend showed by the moving average for the region is in line with the work of Nicholson and Palao (1993), who reported that rainfall in West Africa generally decreased with latitude with essentially zonal isohyets.

### Rainfall Trend/Patterns in Guinea Savannah of Nigeria

Analyses of Standardized Precipitation Index (SPI) over the Guinea Savannah of Nigeria clearly show that the first decade (1982–1991) had positive anomalies, and in the second decade (1981–1990) the whole region had mostly negative anomalies.



**Fig. 4** Weighted average of relative humidity for Sahel, Sudan, and Northern Guinea Savannah zones of Nigeria for 1982 to 2019

However, there was a recovery to positive anomalies in 1991–2000, 2001–2010, and 2011–2018. The dry years were more than the wet years during the 38 years study period. The result shows the region recorded 22 dry years and 15 wet years which corresponds to IPCC projection stating that the region will experience more of wetness as a result of increase in the total precipitation. This is an indication of increased rainfall pattern in the Guinea Savannah region of Nigeria.

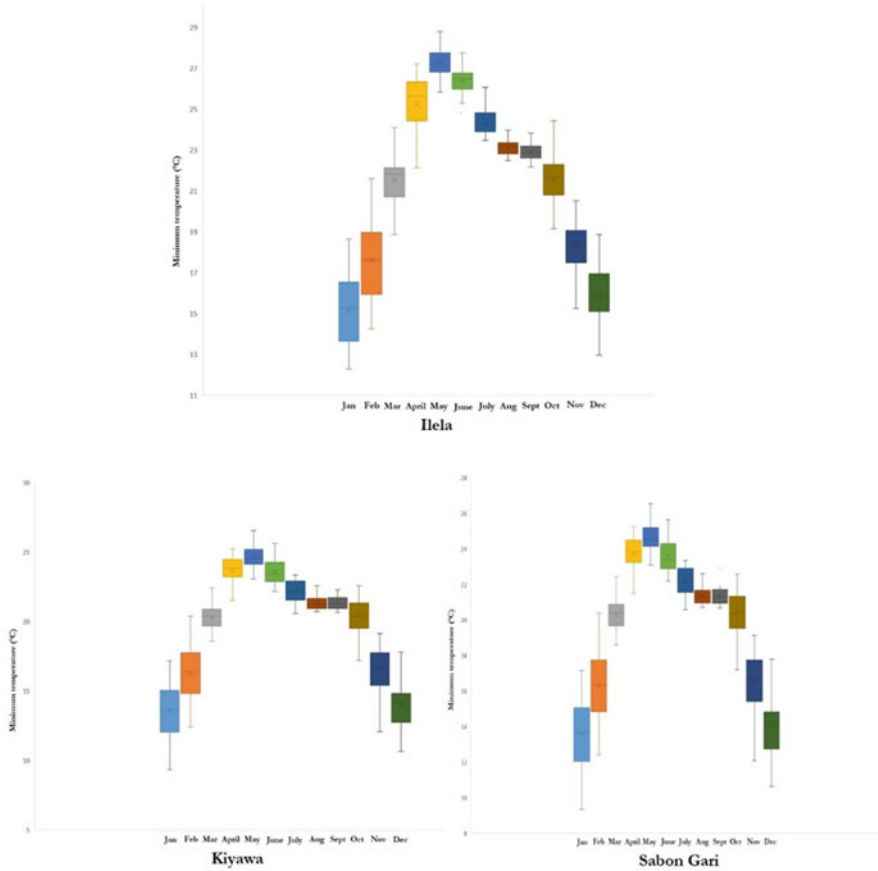
Figure 3 shows the rainfall trend over Guinea Savannah of Nigeria for 1971–2018. In the first decade (1971–1980) and the second decade (1981–1990), it was observed that rainfall was below normal (1971–2000) in the region. During the third (1991–2000), fourth (2001–2010), and current decade (2011–2018) it shows a steady increase in rainfall amount in the region above normal. This result is in line with the work of Nicholson and Palao (1993), who reported that rainfall in West Africa generally decreased with latitude with essentially zonal isohyets.

## Relative Humidity

The variations of relative humidity for the zones being considered in this chapter are depicted in Fig. 4. The highest proportions of relative humidity were recorded in August in the three zones being considered in this chapter. However, the amount of water in the atmosphere was lowest in March of every year across the three regions as shown in Fig. 4. The highest values for relative humidity were 81.11%, 85.55%, and 88.06% in Sahel, Sudan, and Northern Guinea savannah zones, respectively. The lowest value also follows similar trend of decreasing northward the zones with 7.77%, 10.09%, and 12.53%, respectively, for Sahel, Sudan, and Northern Guinea savannah zones.

## Atmospheric Temperature

Figures 5 and 6 show the minimum and maximum temperature in the Sahel, Sudan, and Northern Guinea Savannah zones of Nigeria as represented by Ilala, Kiyawa, and Sabon Gari. The highest value for minimum temperature was observed in May

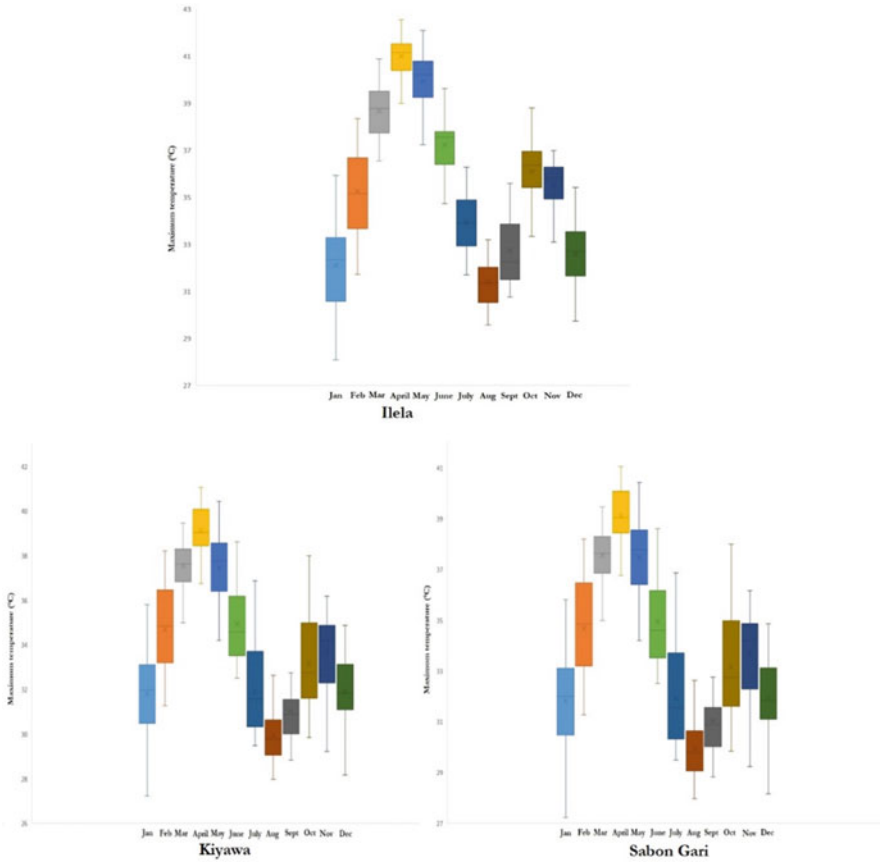


**Fig. 5:** Weighted average of minimum temperature for Sahel, Sudan, and Northern Guinea Savannah zones of Nigeria for 1982 to 2019

and the coldest temperature was in January. While the coldest temperature at Ilela, the Sahel climate, is 12.29 °C; the other two climate zones had similar values of 9.34 °C. Ilela had the highest value for the minimum temperature which was 28.76 °C which was followed by 26.55 °C recorded for Sabon Gari and the least among the three climate zones was 25.19 °C recorded by Kiyawa. The hottest average temperature recorded in all the three zones for the period under consideration in this chapter was 42.55 °C which was recorded at Ilela in the Sahel climate.

### The Concept of Temperature Humidity Index

Figures 7 and 8 show the temperature humidity index as calculated using minimum and maximum temperatures, respectively. Animals, especially cattle, start having mild stress from index of 72 to 78. Severe stress starts from 79 to 88 (Table 1). Using the minimum temperatures as reference, the animals in Sahel ecoclimate were mildly



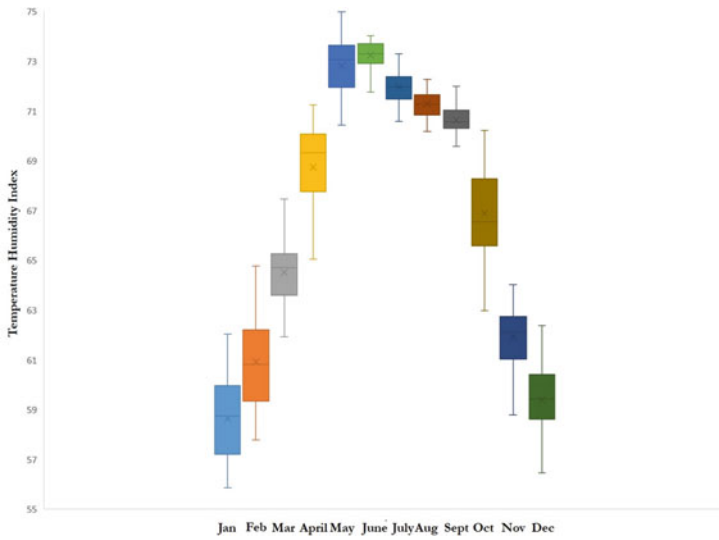
**Fig. 6** Weighted average of maximum temperature for Sahel, Sudan, and Northern Guinea Savannah zones of Nigeria for 1982 to 2019

stressed due to heat and relative humidity interactions in May, June, and some days of July. Considering the animals during the maximum temperatures; they were mildly stressed in January, February, and December. That is the period of *harmattan* in the region. However, the animals are severely stressed for most of the other periods of the year. There were occasions of very severe stress on the animals during some parts of May and June (Fig. 8).

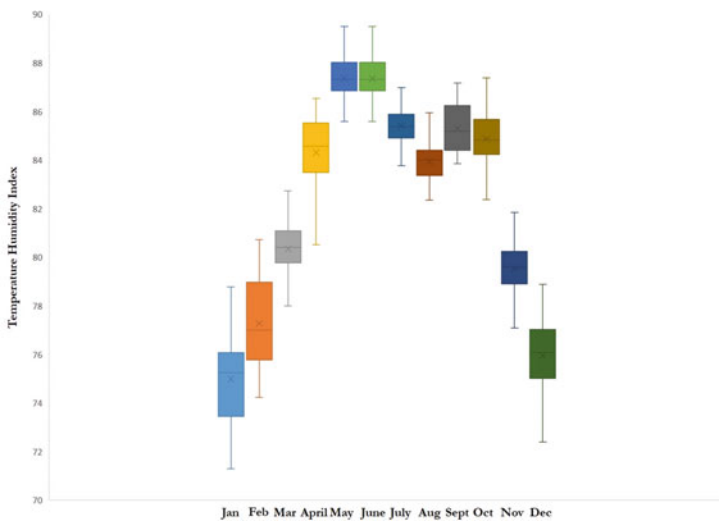
### Livestock Production Characteristics in Sahel, Sudan, and Guinea Savannah Zones of Nigeria

Table 2 shows the production characteristics of livestock stakeholders in the Savannah and *Sudano-Sahelian* zones of Nigeria. Majority of the respondents were livestock farmers (62.3%). Substantial proportions of the respondents were research





**Fig. 7** Temperature humidity index using minimum temperature at Ilela, Sokoto State, as reference point for Sahel ecoclimate zone



**Fig. 8** Temperature humidity index using maximum temperature at Ilela, Sokoto State, as reference point for Sahel ecoclimate zone. According to the information in Table 1

scientists (28.2%) that are dealing with livestock production in the various agro-ecological zones covered in this chapter. About 10% of the respondents were dealing in buying and selling of livestock and poultry. Half the number of the stakeholders interviewed about the interrelationships between climate change and livestock

**Table 1** The temperature humidity index chart

Temp		Relative Humidity (%)																
F	C	25	30	35	40	45	50	55	60	65	70	75	80	85	90	95	100	
77	25.0						72	72	73	73	74	74	75	75	76	76	77	MILD
78	25.6					72	73	73	74	74	75	75	76	76	77	77	77	STRESS
79	26.1				72	76	73	74	74	75	76	76	77	77	78	78	79	
80	26.7		72	72	73	76	74	74	75	76	76	77	78	78	79	79	80	
81	27.2	72	72	73	73	74	75	75	76	77	77	78	78	79	80	80	81	
82	27.8	72	73	73	74	75	75	76	77	77	78	79	79	80	81	81	82	
83	28.3	73	73	74	74	75	76	77	78	78	79	80	80	81	82	82	83	SEVERE
84	28.9	73	74	75	75	76	77	78	78	79	80	80	81	82	83	83	84	STRESS
85	29.4	74	75	75	76	77	78	79	79	80	81	81	82	83	84	84	85	
86	30.0	74	75	76	77	78	78	79	80	81	81	82	83	84	84	85	86	
87	30.6	75	76	77	77	78	79	80	81	81	82	83	86	85	85	86	87	
88	31.1	75	76	77	78	79	80	81	81	82	83	84	85	86	86	87	88	
89	31.7	76	77	78	79	80	81	82	83	84	85	86	86	87	88	89	89	
90	32.2	77	78	79	79	80	81	82	83	84	85	86	86	87	88	89	90	
91	32.8	77	78	79	80	81	82	83	84	85	86	86	87	88	89	90	91	
92	33.3	78	79	80	81	82	83	84	85	85	86	87	88	89	90	91	92	
93	33.9	79	80	80	81	82	83	84	85	86	87	88	89	90	91	92	93	VERY
94	34.4	79	80	81	82	83	84	85	86	87	88	89	90	91	92	93	94	SEVERE
95	35.0	80	81	82	83	84	85	86	87	88	89	90	91	92	93	94	95	STRESS
96	35.6	80	81	82	83	85	86	87	88	89	90	91	92	93	94	95	96	
97	36.1	81	82	83	84	85	86	87	88	89	91	92	93	94	95	96	97	
98	36.7	82	83	84	85	86	87	88	89	90	91	93	94	95	96	97	98	
99	37.2	82	83	84	85	87	88	89	90	91	92	93	94	96	97	98	99	
100	37.8	83	84	85	86	87	88	90	91	92	93	94	95	97	98	99	100	
101	38.3	83	86	86	87	88	89	90	92	93	96	95	96	97	99	100	101	
102	38.9	86	85	86	87	89	90	91	92	96	95	96	97	96	99	101	102	
103	39.4	86	86	87	88	89	91	92	94	95	96	97	98	100	101	102	103	
104	40.0	85	86	88	88	90	91	93	94	95	96	97	99	100	101	103	104	
105	40.6	86	87	88	89	91	92	93	96	96	97	98	99	100	101	104	105	DEAD
106	41.1	86	88	89	90	91	93	94	95	97	98	99	101	102	103	105	106	CATTLE
107	41.7	87	88	89	91	92	94	95	96	98	99	101	102	103	105	106	107	
108	42.2	87	89	90	92	93	94	96	97	98	100	101	102	104	105	106	108	
109	42.8	88	89	91	92	94	95	96	98	99	101	102	103	105	106	107	109	
110	43.3	88	90	91	92	94	96	97	98	100	101	102	104	105	106	108	110	
111	43.9	89	91	93	94	95	96	98	99	101	102	103	105	106	107	109	111	

Source Dr. Frank Wiersma (1990). Department of Agricultural Engineering, University of Arizona, Tucson. Downloaded from <http://www.veterinaryhandbook.com.au>

production preferred intensive management system of production. This can be explained because more than 40% of them are into commercial poultry production. Semi-intensive is a system of choice for ruminant animal production and it is preferred by 40.8% of the stakeholders interviewed in this chapter. Umunna et al. (2014) reported 56.3% of small ruminant producers rearing their stock through semi-intensive system.

The distribution of respondents was also shown in Table 3. The largest proportion of respondents (32.5%) was from Derived Savannah zone of Nigeria. This is commensurate to the very large land area of this zone when compared with some of the other zones (Fig. 1). The least population of respondents (6.7%) was from the Sahel zone. The Sahel zone in Nigeria is found at the uppermost portion of the country. Suleiman (2017) described the Sahel region of Africa as a 3,860-kilometer

**Table 3** Features of Savannah and *Sudano-Sahelian* zones being experienced by respondents

Feature	Sahel N=22	Sudan N = 57	Northern Guinea Savannah N = 61	Southern Guinea Savannah N = 80	Derived Savannah N = 106	Total N = 326
Seasonal variation in availability of natural forage	22 (100.0)	57 (100.0)	58 (95.1)	32 (40.0)	48 (45.3)	217 (66.6)
Extreme high temperatures during dry season	17 (77.3)	38 (66.7)	41 (67.2)	55 (68.8)	57 (53.8)	208 (63.8)
Low temperature during Harmattan	21 (95.5)	46 (80.7)	24 (39.3)	18 (22.5)	18 (17.0)	127 (39.0)
Low precipitation	19 (86.4)	39 (68.4)	17 (27.9)	20 (25.0)	23 (21.7)	118 (36.2)
Desert encroachment	13 (59.1)	26 (45.6)	13 (21.3)	22 (27.5)	19 (17.9)	93 (28.5)
Sunshine hours more than 12 hours	18 (81.8)	42 (73.7)	14 (23.0)	13 (16.3)	5 (4.7)	92 (28.2)
Abundance of grasses and other fodder crops	6 (27.3)	5 (8.8)	16 (26.2)	19 (23.8)	26 (24.5)	72 (22.1)
Low to moderate relative humidity	4 (18.2)	8 (14.0)	11 (18.0)	12 (15.0)	10 (9.4)	45 (13.8)

**Factors responsible for large population of livestock in Savannah and *Sudano-Sahelian* zones of Nigeria**

Abundance of grasses, legumes and other fodder crops	11 (50.0)	33 (57.9)	36 (5.9)	48 (60.0)	67 (63.2)	195 (59.8)
Large expanse of grassland	18 (81.8)	22 (38.6)	29 (47.5)	41 (51.3)	43 (40.6)	153 (46.9)
Low infestation of pathogens during wet season	6 (27.3)	27 (47.4)	15 (24.6)	32 (40.0)	30 (28.3)	110 (33.7)
Low infestation of pathogens during dry season	10 (45.5)	17 (29.8)	22 (36.1)	34 (42.5)	22 (20.8)	105 (32.2)
Mostly flat plane topography	5 (22.7)	11 (19.3)	16 (26.2)	20 (25.0)	21 (19.8)	73 (22.4)

N is the number of respondents; values in parenthesis are the percentages of their respective frequencies

arc-like land mass lying to the immediate South of the Sahara Desert and stretching East-West across the breadth of the African continent. He further stated that the region stretches from Senegal on the Atlantic coast, through parts of Mauritania, Mali, Burkina Faso, Niger, Nigeria, Chad, and Sudan to Eritrea on the Red Sea coast.

Almost all the respondents (92%) were aware of the concept of climate change and its other attribute of global warming. Very high awareness level of climate change (88%) was reported by Adebayo and Oruonye (2012) among farmers in Northern Taraba State.

The features that best describe Savannah and *Sudano-Sahelian* zones of Nigeria were presented in Table 3. Seasonal variation in availability of natural forage was reported by all the respondents interviewed in Sahel and Sudan zones. About 95% of the respondents in Northern Guinea Savannah zones corroborated the scarcity or non-availability of natural forages during the dry seasons. Life-threatening high temperature during dry season was also reported as 63.8% by 326 respondents. Low temperatures during *Harmattan* period were reported as 95.5%, 80.7%, 39.3%, 22.5%, and 17.0% by respondents from Sahel, Sudan, Northern Guinea Savannah, Southern Guinea Savannah, and Derived Savannah, respectively.

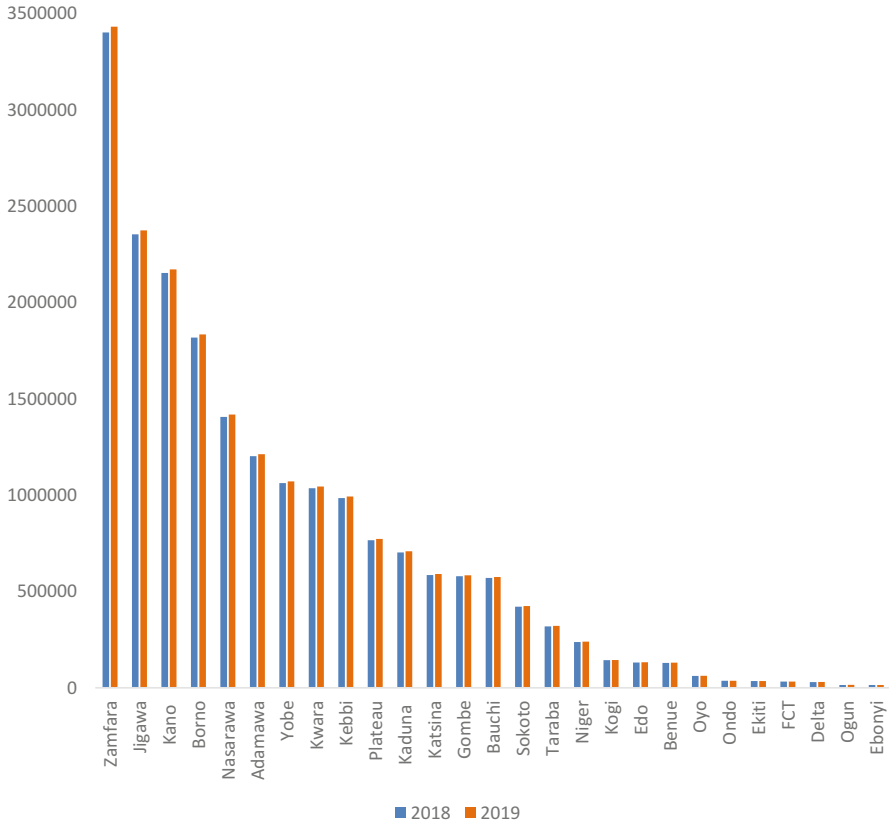
The *Harmattan* is a season in the West African subcontinent starting from November to mid-March. The season is highly dependent on air pressure variability in the Mediterranean area. The *Harmattan* period is dust laden and also characterized by low temperatures (Schwinghamart and Schutt 2008). In Sahelian parts of Africa, Aeolian dust transport is made possible by several wind systems (Jäkel 2004; Engelstaedter et al. 2006). One of the wind system is *Harmattan* (Schwinghamart and Schutt 2008).

Low precipitation was also reported in Table 3. The proportions of the respondents that stated low precipitation as a prominent feature of the climate system were highest for Sahel (86.4%) and lowest for Derived Savannah (21.7%). This is an indication that there is more aridity in the Sahel and less in the Derived Savannah. Variability in Sahel rainfall is inextricably connected with the variability of the atmospheric circulation. Annual mean rainfall in the Sahel of Nigeria is less than 200 mm (Biasutti 2019). The author opined that across the zones, abundance or scarcity of rainfall and its distribution over the rainy season and the associated maximum temperature extremes determines the success or failure of farming system with its antecedent effects on livestock production. Desert encroachments were reported as a feature of Sahel (59.1%) and Sudan (45.6%) zones. Nigeria is faced with rapid desert encroachment affecting 15 states in the North. Most of the States covered in this chapter were described as desertification frontline States by Olagunju (2015).

---

## Livestock Population in Nigeria

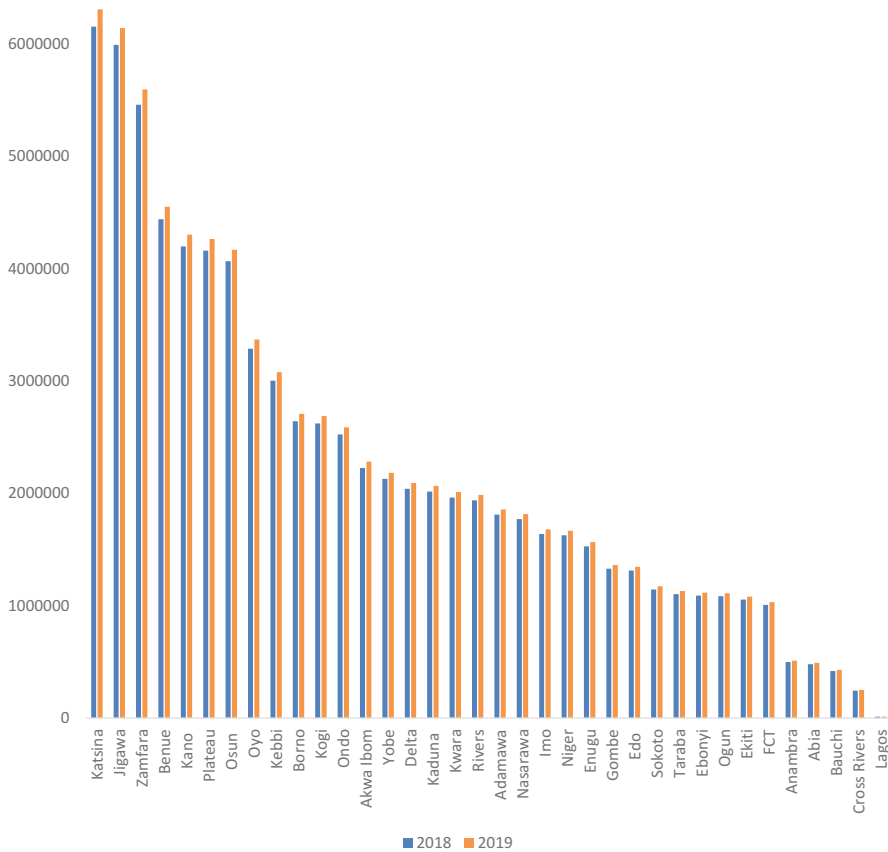
The total population of cattle in Nigeria was 20,407,607 in 2019 as against 20,231,589 in 2018. The distribution of cattle in States within Nigeria was illustrated through Fig. 9. Zamfara tops the list of States with 3,432,486 heads of cattle. The goat population in Nigeria was totaled at 46,757,458 in 2019. The highest population of goats (5,488,904) in 2019 was recorded in Katsina State (Fig. 10). Like as it is for cattle, Zamfara State tops the list of states for sheep production with the population size of 7,314,023 sheep (Fig. 11). These populations were reported in the Executive summary of Annual Performance Survey of National Agricultural Extension and Research Liaison Services in Nigeria (NAERLS 2019).



**Fig. 9** Cattle population in Nigeria. (Source: Federal Department of Animal Production and Husbandry Services, FMARD, Abuja (Reported by NAERLS 2019))

The total populations of donkeys in Nigeria were 978,402 and 979,380 for 2018 and 2019, respectively (NAERLS 2019). The beast of burden (donkey), a very resilient animal is found mostly in about 11 states of the country (all within Sahel, Sudan, and Northern Guinea Savannah Zone of Nigeria) with the highest population found in Zamfara State (331,641) in 2019. Other states with prominent populations of donkeys in 2019 were Sokoto (153,657), Borno (143,707), Kano (135,962), Kebbi (82,870), Jigawa (25,135), and Gombe (14,241). Some other states like Bauchi and Yobe had populations of donkeys that are less than 1,500.

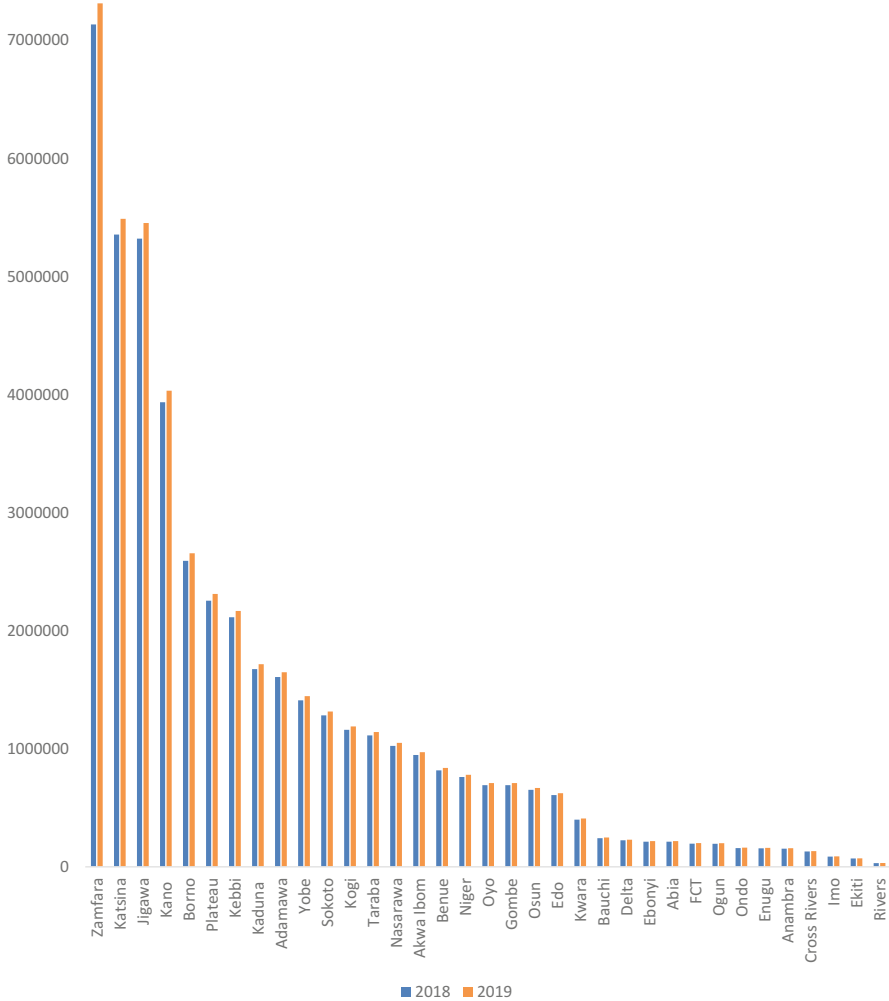
Camel is another livestock used as beast of burden in Nigeria. The total populations of camels in the country were 279,956 and 280,235 for 2018 and 2019, respectively. Almost half of all the camel population in Nigeria was found in Kano State with 128,104 heads of camel. Other states with some populations of camel in 2019 were Sokoto (60,346), Kebbi (50,483), Jigawa (12,851), Katsina (9,581), Bauchi (9,475), Niger (3,270), and Yobe (501). It was of note that the rate of increase in population of camel and donkey is very negligible. These animals (camel and donkey) are reported to



**Fig. 10** Goat population in Nigeria. (Source: Federal Department of Animal Production and Husbandry Services, FMARD, Abuja (Reported by NAERLS 2019))

be dwindling in number as there is increased consumption and less production, therefore ways of increasing the population of this animal should be scientifically exploited to avoid the extinction of the species (Nelson et al. 2015).

The possible factors responsible for large population of livestock in the Savannah and *Sudano – Sahelian* zones of Nigeria were presented in Table 3. On the top of the list of such factors is the abundance of grasses, legumes, and other fodder crops as indicated by 59.8% of the respondents. Large expanse of grassland was also said to be a prominent factor enabling large population of livestock on the semiarid zone of Sahel, Sudan, and the Guinea Savannahs. Other factors being reported in favor of the large population of livestock in the zones being considered in this chapter were low infestation of pathogens during wet and dry seasons with 33.7% and 32.2%, respectively. About 22% of the respondents stated that the flat plane topography in the zones might have contributed to the enormous populations of livestock being found in the zones. Lawal-Adebowale (2012) stated that the concentration of



**Fig. 11** Sheep population in Nigeria. (Source: Federal Department of Animal Production and Husbandry Services, FMARD, Abuja (Reported by NAERLS 2019))

Nigeria’s livestock-base in the northern region is most likely to have been influenced by the ecological condition of the region which is characterized by low rainfall duration, lighter sandy soils, and longer dry season. This submission was predicated by the fact that drier tropics or semi-arid regions are more favorable to the ruminants. However, concerted efforts need to be made at retaining the large population of livestock in these regions (Savannah and *Sudano-Sahelian*) because livestock production will be possibly limited in the future by climate variability as animal’s water consumption is expected to increase. There will be more demand for agricultural lands because of increase due to need for 70% growth in production, and food

security concern since about one-third of the global cereal harvest will be needed for livestock feed (Rojas-Downing et al. 2017).

Table 4 showed the stakeholders perception of the effect of changes on climatic elements of livestock production in the Savannah and *Sudano-Sahelian* zone of Nigeria. About 77% of all the respondents agreed to the fact that changes in climatic

**Table 4** Stakeholders' perception of effect of changes in climatic elements on livestock production in the Savannah and Sudano-Sahelian zones of Nigeria

	Sahel N = 22	Sudan N = 57	Northern Guinea Savannah N = 61	Southern Guinea Savannah N = 80	Derived Savannah N = 106	Total N = 326
<b>Changes in climatic elements affect livestock production in the zones</b>						
Strongly agree	10 (45.5)	11 (19.3)	19 (31.1)	24 (30.0)	38 (35.8)	102 (31.3)
Agree	7 (31.8)	31 (54.4)	23 (37.7)	45 (56.2)	42 (39.6)	148 (45.4)
Neutral	0 (0.0)	4 (7.0)	8 (13.1)	4 (0.5)	9 (8.5)	25 (7.7)
Disagree	1 (4.5)	4 (7.0)	2 (3.3)	2 (2.5)	4 (3.8)	13 (4.0)
Strongly disagree	4 (1.2)	7 (2.1)	9 (2.8)	5 (6.2)	13 (12.3)	38 (11.7)
<b>Perception about climatic elements that have the most variation in the zones</b>						
Atmospheric temperature	9 (40.9)	31 (54.4)	33 (54.1)	41 (51.2)	49 (46.2)	163 (50.0)
Rainfall	10	21	19	28	42	120 (36.8)
Sunshine hour	2 (9.1)	3 (5.3)	3 (4.9)	7 (8.8)	4 (3.8)	19 (5.8)
Relative humidity	0 (0.0)	2 (3.5)	4 (6.6)	2 (2.5)	8 (7.5)	16 (4.9)
Atmospheric pressure	1 (4.5)	0 (0.0)	1 (1.6)	2 (2.5)	3 (2.8)	7 (2.1)
Solar radiation	0 (0.0)	0 (0.0)	1 (0.3)	0 (0.0)	0 (0.0)	1 (0.3)
<b>Perception about the climatic elements that are capable of affecting livestock productivity when their variations are in the extreme</b>						
Atmospheric temperature	17 (77.3)	39 (68.4)	48 (78.7)	54 (67.5)	69 (65.1)	227 (69.6)
Relative humidity	2 (9.1)	12 (21.1)	14 (23.0)	17 (21.3)	35 (33.0)	80 (24.5)
Solar radiation	3 (13.6)	13 (22.8)	9 (14.8)	15 (18.8)	18 (20.0)	58 (17.8)
Sunshine hours	4 (18.2)	7 (12.3)	12 (19.7)	19 (23.8)	21 (19.8)	63 (19.3)
Greenhouse gases	2 (9.1)	4 (7.0)	9 (14.8)	4 (5.0)	7 (6.6)	26 (10.0)

N is the number of respondents; values in parenthesis are the percentages of their respective frequencies



elements affect livestock productivity. Kebede (2016) related the foremost reaction of animals under thermal weather as increase in respiration rate, rectal temperature, and heart rate. He further stated that the anticipated rise in temperature due to climate change is likely to aggravate the heat stress in livestock, adversely affecting their productive and reproductive performance and even death in extreme cases. The respondents observed that the climatic elements with most variations are atmospheric temperature (50.0%), rainfall (36.8%), and sunshine hour (5.8%). The climatic element with the least variation as being reported by the respondents is solar radiation (0.3%). Atmospheric temperature was also implicated by 69.9% of the respondents as a climatic element with the most debilitating effect on livestock when its variation is in the extreme. This was followed by relative humidity with 24.5% of the respondents stating that its effect can really affect livestock productivity.

### **Adaptive Measures Against the Effect of Climate Change on Livestock Production**

Useable adaptive measures toward reducing the effects of climate change on livestock production are presented in Table 5. About 55% of the respondents agreed that the use of adaptive measures in alleviating the effect of climate change on livestock is capable of reducing its debilitating effect on livestock. The rest of the respondents, about 45%, were either neutral or disagreed with the fact that adaptive measures can mitigate the effect of climate change. It will be necessary to educate those that disagree on this very important fact. To guide the evolution of livestock production systems under the increase of temperature and extreme events, better information is needed regarding biophysical and social vulnerability, and this must be integrated with agriculture and livestock components (Nardone et al. 2010). The specific adaptive measures used by livestock farmers in the study locations are shown in Table 5 as well. At the top of the adaptive features of choice by respondents is provision of housing facilities for animals which was indicated by about 60% of the respondents. Provision of abundant water and supplements feeding were also indicated as adaptive measures by 45.4% and 44.2% of the respondents, respectively. Planting of trees to provide shades for livestock was of great interest because of the sustainable effect of this adaptive measure to livestock production. Trees are known to absorb carbon dioxide produced by man and animals that is apart from their primary function of shades as intended by livestock farmers. Development of super-absorbent fake leaves was proposed by scientists (Vince 2012) as a means of modulating the global temperature. This method was proposed as capable of removal of greenhouse gas from the atmosphere. The benefits of the introduction of artificial plants will be centered on geoengineering the planet which will be beyond its cooling effects.

Timely control of internal and external parasites was a choice of adaptive measure by a third of the respondents (31.3%). This is expected to eliminate the stress on health status of the animals which will go a long way in stabilizing the internal physiological equilibrium of the animals. If properly done, the animals will have enough energy to

**Table 5** Useable adaptive measures toward reducing the effect of climate change on livestock production in Savannah and Sudano-Sahelian zones of Nigeria

Feature	Sahel <i>N</i> = 22	Sudan <i>N</i> = 57	Northern Guinea Savannah <i>N</i> = 61	Southern Guinea Savannah <i>N</i> = 80	Derived Savannah <i>N</i> = 106	Total <i>N</i> = 326
<b>Stakeholders perceptions about reducing the effect of climate change on livestock production through the use of adaptive measures</b>						
Strongly agree	2 (9.1)	5 (8.8)	0 (0.0)	0 (0.0)	0 (0.0)	7 (2.1)
Agree	10 (45.5)	31 (54.4)	28 (45.9)	45 (56.3)	58 (54.7)	172 (52.8)
Neutral	4 (18.2)	6 (10.5)	3 (4.9)	6 (7.5)	5 (4.7)	24 (7.4)
Disagree	0 (0.0)	4 (7.0)	1 (1.6)	0 (0.0)	5 (4.7)	10 (3.1)
Strongly disagree	6 (27.3)	11 (19.3)	29 (47.5)	29 (36.3)	38 (35.8)	113 (34.7)
<b>Adaptive measures used by livestock production stakeholders</b>						
Provision of housing for animals	17 (77.3)	41 (71.9)	35 (57.4)	51 (63.8)	50 (47.2)	194 (59.5)
Frequent cleaning of animal houses	6 (27.3)	17 (29.8)	24 (39.3)	24 (30.0)	31 (29.2)	102 (31.3)
Provision of supplement feeding	9 (40.9)	31 (54.4)	24 (39.3)	41 (51.3)	39 (36.8)	144 (44.2)
Provision of water in abundance	12 (54.5)	31 (54.4)	27 (44.3)	38 (47.5)	39 (36.8)	148 (45.4)
Timely control of internal and external parasites	7 (31.8)	17 (29.8)	19 (31.1)	28 (35.0)	32 (30.2)	103 (31.6)
Storage of excess feed materials	9 (40.9)	18 (31.6)	24 (39.3)	31 (38.8)	24 (38.8)	106 (32.5)
Cultivation of drought tolerant varieties of forage crops	4 (18.2)	18 (31.6)	19 (31.1)	27 (33.8)	23 (21.7)	91 (27.9)
Feeding of livestock with crop residues	8 (36.4)	16 (28.1)	20 (32.8)	23 (28.8)	25 (23.6)	92 (28.2)
Making of multi-nutrient blocks	3 (13.6)	8 (14.0)	10 (16.4)	14 (17.5)	13 (12.3)	48 (14.7)
Feeding of livestock with multi-nutrient blocks	7 (31.8)	10 (17.5)	7 (11.5)	12 (15.0)	11 (10.4)	47 (14.4)
Seasonal migration of animals	3 (13.6)	2 (3.5)	12 (19.7)	6 (7.5)	17 (16.0)	40 (12.3)

(continued)

**Table 5** (continued)

Feature	Sahel <i>N</i> = 22	Sudan <i>N</i> = 57	Northern Guinea Savannah <i>N</i> = 61	Southern Guinea Savannah <i>N</i> = 80	Derived Savannah <i>N</i> = 106	Total <i>N</i> = 326
Irrigation of pasture during dry season	5 (22.7)	7 (12.3)	13 (21.3)	21 (26.3)	8 (7.5)	54 (16.6)
Establishment of ranch	4 (18.2)	12 (21.1)	11 (18.0)	21 (26.3)	20 (18.9)	68 (20.9)
Planting of trees to provide shades for livestock	11 (50)	26 (45.6)	29 (47.5)	37 (46.3)	30 (28.3)	133 (40.8)
Storage of crop residues obtainable during crop harvest	7 (31.8)	14 (24.6)	20 (32.8)	23 (28.8)	22 (20.8)	86 (26.4)

*N* is the number of respondents; values in parenthesis are the percentages of their respective frequencies

combat stress from the environment. Storage of excess feed, especially during harvest, was stated as an adaptive measure by 32.5% of the respondents. This adaptive measure can be linked with another one that was also stated by the stakeholders, storage of crop residues obtainable during harvest (26.4%). These two measures are some of the important components of crop-livestock integration systems as discussed by Iyiola-Tunji et al. (2015). Feeding livestock with crop residues in a well-planned basis on the nutrient requirements and biomass needs of these animals will ensure adequate usage of the crop residues. Establishment of ranch, irrigation of pasture during dry season, making of multi-nutrient blocks, feeding of livestock with multi-nutrient blocks and seasonal migration of animals were of the other adaptive measures being carried out to combat the effect of climate change as reported by substantial proportion of the respondents. Integrating livestock and crop production will serve as a form of conservation, which will enable shifting from the traditional systems which is focused exclusively on livestock or crop to a new approach which sustainably combines both. **Agroforestry** (establishing trees alongside crops and pastures in a mix) as a land management approach can help maintain the balance between agricultural production, environmental protection, and carbon sequestration to offset emissions from the sector. Agroforestry may increase productivity and improve quality of air, soil, and water, biodiversity, pests and diseases, and improves nutrient cycling (Jose 2009; Smith et al. 2012).

### Contribution of Livestock Production Activities Toward Climate Change

Table 6 showed the contribution of livestock production activities toward climate change. A lot of the stakeholders interviewed (62.3%) were aware of the

**Table 6** Contribution of livestock production activities toward climate change

	Sahel <i>N</i> = 22	Sudan <i>N</i> = 57	Northern Guinea Savannah <i>N</i> = 61	Southern Guinea Savannah <i>N</i> = 80	Derived Savannah <i>N</i> = 106	Total <i>N</i> = 326
<b>Stakeholder awareness of contribution of livestock production activities to changes in climate and global warming</b>						
Yes	16 (72.7)	32 (56.1)	43 (70.5)	44 (55.0)	68 (64.2)	203 (62.3)
No	2 (9.1)	11 (19.3)	1 (1.6)	11 (13.8)	8 (7.5)	33 (10.1)
Maybe	1 (4.5)	2 (3.5)	9 (14.8)	6 (7.5)	7 (6.6)	25 (7.7)
<b>Livestock generates substantial proportions of global greenhouse gas emission that are very bad for the environment</b>						
Yes	14 (63.6)	28 (49.1)	35 (57.4)	35 (43.8)	62 (58.5)	174 (53.4)
No	5 (22.7)	16 (28.1)	11 (18.0)	33 (41.3)	24 (22.6)	89 (27.3)
Maybe	3 (13.6)	11 (19.3)	15 (24.6)	12 (15.0)	19 (17.9)	60 (18.4)
<b>Livestock and their by-products account for several millions tons of carbon dioxide production per year</b>						
Yes	12 (54.5)	22 (38.6)	25 (40.9)	28 (35.0)	57 (53.8)	114 (35.0)
No	7 (31.8)	21 (36.8)	13 (21.3)	27 (33.8)	25 (23.6)	93 (28.5)
Maybe	3 (13.6)	14 (24.6)	23 (37.7)	25 (31.3)	23 (21.7)	88 (27.0)
<b>Extensive system of livestock production plays a critical role in land degradation, climate change, water, and biodiversity loss</b>						
Yes	14 (63.6)	29 (5.1)	44 (72.1)	67 (83.8)	86 (81.1)	240 (73.6)
No	2 (9.1)	11 (19.3)	5 (8.2)	6 (7.5)	6 (5.7)	30 (9.2)
Maybe	5 (22.7)	14 (24.6)	9 (14.8)	7 (8.8)	14 (13.2)	49 (15.0)
<b>Economic, social, health, and environmental perspectives will be critical to solving the problems surrounding livestock production</b>						
Strongly agree	6 (27.3)	18 (31.6)	26 (42.6)	32 (40.0)	48 (45.3)	130 (39.9)
Agree	12 (54.5)	27 (47.4)	29 (47.5)	41 (51.3)	47 (44.3)	156 (47.9)
Neutral	3 (13.6)	5 (8.8)	0 (0.0)	5 (6.3)	7 (6.6)	20 (6.1)
Disagree	0 (0.0)	5 (8.8)	5 (8.2)	2 (2.5)	4 (3.8)	16 (4.9)
Strongly disagree	1 (4.5)	2 (3.5)	0 (0.0)	0 (0.0)	0 (0.0)	3 (0.9)

*N* is the number of respondents; values in parenthesis are the percentages of their respective frequencies

contribution of livestock production to climate change. Generations of substantial proportions of global greenhouse gases that are very bad for the environment were on the knowledge of more than half of the respondents (53.4%). Just about the third (35%) of the respondents were aware that livestock and their by-products account for several million tons of carbon dioxide production per year. Very large proportions (73.6%) of respondents were aware that extensive system of livestock production plays a critical role in land degradation, climate change, water, and biodiversity loss. About 90% of the respondents however believed that economic, social, health, and environment perspectives are critical to solving the problems of the contributions of livestock production to climate change and global warning. In 2006, an FAO publication entitled “Livestock’s long shadow – Environmental issues and options” indicated that the influence of livestock on the environment was much greater than it was considered. This provided detailed perspectives on the impact of livestock on water, biodiversity, and climate change. The issue on climate change and 18% estimated contribution of livestock to overall GHG emissions is the concern that attracted the most attention. The FAO (2006) estimated 18% anthropogenic GHG emissions from livestock industry is disapproved by Goodland and Anhang (2009) who noted that the figure under-tallies emissions from certain production activities, underestimates demand, and absolutely omits some categories of emissions. They estimated that livestock production is contributing about 51% of anthropogenic GHG emissions. Goodland and Anhang (2009) revealed that CO<sub>2</sub> from livestock respiration was ignored as a source of the GHGs from the FAO study (2006). Both manure and enteric fermentation contribute some 80% of methane emissions from agricultural activities and about 30–40% of the overall anthropogenic methane emissions (FAO 2006). The 62–89% of greenhouse emission recorded in this chapter was similar to the findings of FAO (2006). Similarly, there is an increasing awareness within the policy and research communities that fast growth in consumption and production of livestock commodities is contributing to variety of environmental problems. The main notable issue is livestock’s significant contribution to anthropogenic emissions. Majority of the revenue is generated by pigs, chickens, sheep, goats, beef, and dairy cattle. These five species of livestock generate 92% of the overall revenue from livestock in Africa. In most rural communities, livestock is the only property of the poor, but it is highly susceptible to climate changes and extremes (Easterling and Aggarwal 2007; FAO 2007; Calvasa et al. 2009). The influence of climate change is anticipated to increase the susceptibility of livestock industry and reinforce current factors that are having impact on livestock farming systems (Gill and Smith 2008). The overall GHG emissions from livestock supply chains are approximately 7.1 gigatons CO<sub>2</sub>-equivalent annually for the 2005 reference point forming about 14.5 % of all emissions induced by humans (IPCC 2007a). About 44 % of the livestock industry emissions are in the form of CH<sub>4</sub>. Nitrous oxide and carbon dioxide represent 29% and 27%, respectively. Livestock supply chains emit 9.2 gigatons CO<sub>2</sub>-eq of CO<sub>2</sub> annually or 5% of anthropogenic CO<sub>2</sub> emissions (IPCC 2007b). According to IPCC (2007b), 44% of anthropogenic CH<sub>4</sub> emissions or 3.1 gigatons CO<sub>2</sub>-eq of CH<sub>4</sub> every year and 53% of anthropogenic N<sub>2</sub>O emissions or 2 gigatons CO<sub>2</sub>-eq of N<sub>2</sub>O are produced annually. Similar results were observed in

this chapter, which reported that livestock products account for 88–93% (Table 6) of the carbon dioxide production per year.

### **Adaptive Measures Toward Mitigation of Effect of Climate Change on Livestock**

An adaptation such as the modification of production and management systems involves diversification of livestock animals and crops, integration of livestock systems with forestry and crop production, and changing the timing and locations of farm operations (IFAD 2010). Diversification of livestock and crop varieties can increase drought and heat wave tolerance, and may increase livestock production when animals are exposed to temperature and precipitation stresses. In addition, this diversity of crops and livestock animals is effective in fighting against climate change-related diseases and pest outbreaks (Kurukulasuriya and Rosenthal 2003; Batima et al. 2005; IFAD 2010). Changes in breeding strategies can help animals increase their tolerance to heat stress and diseases and improve their reproduction and growth development (Rowlinson et al. 2008; Henry et al. 2012). Adjusting animal diets can also be used as a mitigation measure, by changing the volume and composition of manure. GHG emissions can be reduced by balancing dietary proteins and feed supplements. If protein intake is reduced, the nitrogen excreted by animals can also be reduced. Supplements such as tannins are also known to have the potential to reduce emissions. Tannins are able to displace the nitrogen excretion from urine to feces to produce an overall reduction in emissions (Hess et al. 2006; Dickie et al. 2014). Some of the adaptable technologies for reducing the effect of livestock production activities on climate change and vice versa are also presented in Table 7 and discussions on each of them are presented below.

#### **Proper Livestock Health Management and Welfare**

On the top of the list of technologies as dictated by the respondents (63.2%) is proper livestock health management and welfare. Reducing greenhouse gas (GHG) emissions may seem like extra work that can hurt business, but in reality, best management practices for reducing GHG emissions can be economical (Lindgren 2019). Animals that are maintained in optimum health conditions and given adequate welfare will have improved production efficiency and reduction of methane production from digestion of feeds.

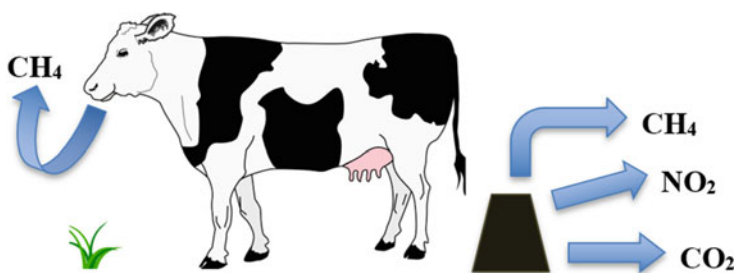
#### **Adequate Waste Management and Utilization**

Almost equally important technology is adequate waste management and utilization as proposed by 59.2% of the respondents. The major contribution to greenhouse gas emissions is methane (CH<sub>4</sub>) from ruminant animals through belching when the animals digest their feeds (Plate I). The other sources of the deleterious gases are from fecal waste excretion and storage. Adequate waste management and utilization is capable of reducing the quantity of the greenhouse gases

**Table 7** Adaptable technologies for reducing the effect of livestock production activities on climate change

Adaptable technologies	Sahel <i>N</i> = 22	Sudan <i>N</i> = 57	Northern Guinea Savannah <i>N</i> = 61	Southern Guinea Savannah <i>N</i> = 80	Derived Savannah <i>N</i> = 106	Total <i>N</i> = 326
Proper livestock health management and welfare	13 (59.1)	40 (70.2)	34 (55.7)	55 (68.8)	64 (60.4)	206 (63.2)
Adequate waste management and utilization	13 (59.1)	32 (56.1)	40 (65.6)	43 (53.8)	65 (61.3)	193 (59.2)
Crop-livestock integration system	9 (40.9)	28 (49.1)	32 (52.5)	36 (45.0)	59 (55.7)	164 (50.3)
Breeding for more productive animals	12 (54.5)	31 (54.4)	28 (45.9)	43 (53.8)	49 (46.2)	163 (50.0)
Use of methane reducing feed additives	9 (40.9)	21 (36.8)	21 (34.4)	13 (16.3)	22 (20.8)	86 (26.4)
Ranching	8 (36.4)	15 (26.3)	18 (29.5)	17 (21.3)	26 (24.5)	84 (25.8)

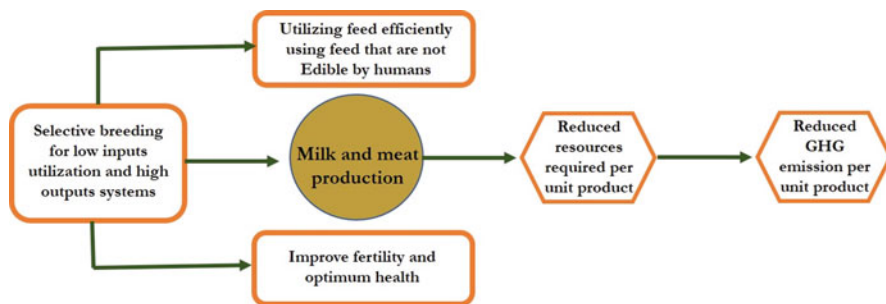
*N* is the number of respondents; values in parenthesis are the percentages of their respective frequencies

**Plate 1** Greenhouse gas emissions from cattle production. (Source: Lindgren (2019))

emissions. Livestock farmers in the Sahel, Sudan, and the Guinea Savannah zones of Nigeria use the fecal waste as organic fertilizers for crop production. There were occasions where the litter materials from poultry production are fed to cattle (Lamidi 2005).

### Crop-Livestock Integration Systems

A lot of the effect of livestock production on climate change can be eliminated if the farmers can engage in crop-livestock integration systems. About half of the respondents (50.3%) agreed to this fact. Ickowicz et al. (2012) presented three variants of CLIS in



**Fig. 12** Production efficiencies using management that can reduce GHG emissions beginning with selective breeding of a genotype for a particular system. (Adapted from Bell et al. (2012); modified by Iyiola-Tunji, A.O.) © 2012 Bell MJ, Eckard RJ, Pryce JE. Published in [short citation] under CC BY 3.0 license. Available from: <http://dx.doi.org/10.5772/50395>

arid and semiarid areas: (i) livestock only grazing systems, (ii) rainfed mixed crop-livestock systems, and (iii) irrigated mixed crop-livestock systems. CLIS combine cereal crops (mainly millet, cowpea, sorghum, cotton and groundnut) and majorly ruminant animal production activities in different proportions. Crop-livestock integration systems (CLIS) enable recycling of products and wastes between crop production and livestock production. These methods are capable of increasing feed resources availability during the dry season and also replenish the soil for crop production through the use of fecal wastes from livestock. The major engagement of agropastoralists in Nigeria involves CLIS in a way though biomass inputs and outputs recycling are not scientifically calculated by the farmers (Iyiola-Tunji et al. 2017).

### Breeding for More Productive Animals

Breeding for more productive animals was suggested by 50% of the respondents as an adaptive measure for reduction of greenhouse gas emissions. Selective breeding that is aimed at improving production efficiencies had been reported to result into increase productivity and gross efficiency by optimize the cost of production and reduce the number of animals that are needed to produce the same quantity of products (Bell et al. 2012). Reports from van de Haar and St. Pierr (2006) and Chagunda et al. (2009) related that more energy-efficient animals produce less waste in the form of methane and nitrogen excretion per unit product. The path toward reduced emission of greenhouse gases through selective breeding is depicted in Fig. 12. Animals that are selectively bred to utilize low inputs and give high outputs are expected to produce milk and meat (as the case may be) efficiently. The quantity of GHG emissions will be reduced once the number of animals put into productive is reduced.

### Use of Methane-Reducing Feed Additives

The use of methane reducing feed additives was stated by 26.4% of the respondents as being capable of reducing the effect of livestock production activities on GHG



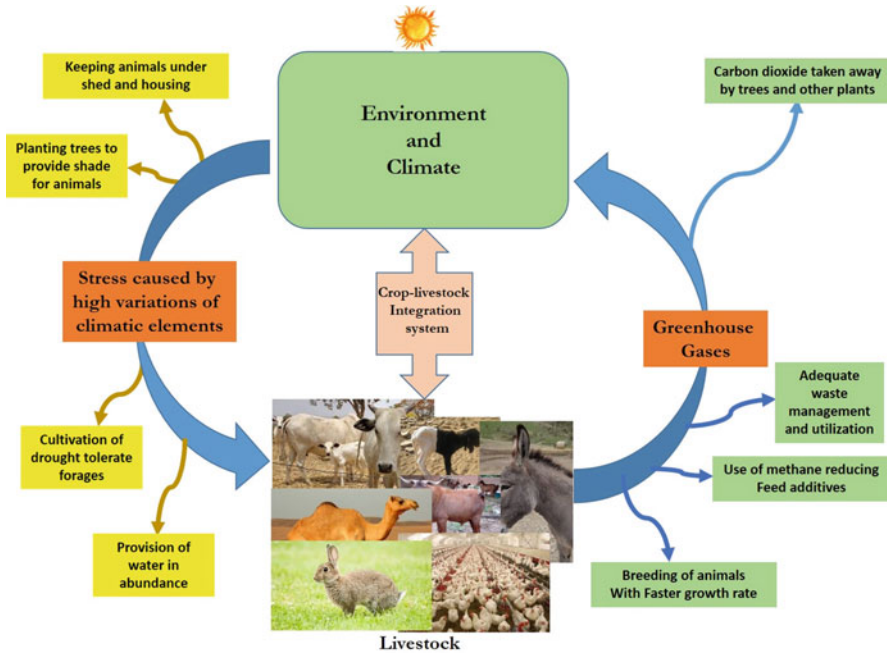
emissions. Kataria (2015) observed that the practice of using feed additives to mitigate enteric methane production is more prominent in developed countries of the world where ruminant livestock are kept in well-managed production systems and generally fed diets that are very high in digestibility and nutrients. The results of this practice according to the author are an efficient production (milk or meat) relative to the amount of methane emitted. Klop (2016) expressed the advantage of using feed additives to mitigate GHG emissions as they are supplied in such amounts that the basal diet composition will not be largely affected by the feed additives (Klop 2016). Methane-reducing feed additives and supplements inhibit methanogens in the rumen, and subsequently reduce enteric methane emissions (Curnow 2019). Methane-reducing feed additives and supplements can be synthetic chemicals, natural supplements and compounds, such as tannins, and seaweed fats and oils (Curnow 2019). van Zijderveld et al. (2010) had experimented with lauric acid, myristic acid, linseed oil, and calcium fumarate as additives and obtained favorable results in the reduction of GHG emissions. Sunflower oil and monensin offer the greatest reductions in methane without substantial reductions in diet digestibility (Beauchemin and McGinn 2006). It is of note that the practice of using feed additives as an adaptive measure to reduce GHG emissions in developing countries like Nigeria is almost nonexistent.

## Ranching

To further reduce livestock's greenhouse gas emissions while continuing to provide meat for a growing world population, beef cattle ranchers are proactively implementing methane-reducing methods to manage manure, improve soil health, and enhance herd efficiency. Ranching will enable farmers to consciously engage in practices that are capable of mitigating the effect of climate change on their livestock and also make attempt at GHG emissions from their livestock.

## Pathway of Responses

The dual pathways of responses between climate change and livestock production activities are depicted in Fig. 13. Activities from livestock have very high tendencies to impact negatively on the environment and eventually causing unfavorable variability of climate and its elements, which is indicated by the blue big (fat) arrow that goes away from livestock to the environment and climate. The major component of the activities of livestock that is known to cause injury to the environment as depicted in Fig. 13 is the production of greenhouse gases (shown in an orange box on the right-hand side of the pathway). From the respondents in this study, some adaptive measures were stated as having controlling and mitigating effect at reducing the effect of activities of livestock on the climate and the environment. When these measures such as planting of trees to absorb CO<sub>2</sub>, adequate waste management and utilization, feeding of livestock with methane reducing feed additives, and breeding of animals with faster growth rate are effectively deployed, the destruction of the environment will be reduced. Key breeding traits associated with climate change



**Fig. 13** Dual pathways of responses between climate and livestock

resilience and adaptation include thermal tolerance, low quality feed, high survival rate, disease resistance, good body condition, and animal morphology (Hoffmann 2008; Oseni and Bebe 2008). In general, developing countries have a weak capacity for high-tech breeding programs toward livestock improvement (IFAD 2002). Therefore, programs based on controlled mating methods are likely to be more appropriate. These programs usually do not produce immediate improvements. Improvements are usually not seen for at least one growing season, so a livestock producer must be able to incorporate long-term planning into production management strategies. Such measures could include:

- Identifying and strengthening local breeds that have adapted to local climatic stress and feed sources
- Improving local genetics through cross-breeding with heat and disease tolerant breeds

The environment and climate on the other side of the dual pathway is also known to induce stress on livestock. The respondents in this chapter stated that the components of the pathway that are in yellow boxes are capable of limiting the stress caused by high variations of climatic elements. The concept of crop-livestock integration system is advocated in this chapter as beneficial to livestock and environment in the short and long run.

### Predicting Climatic Conditions Using Machine Learning Approach

The ability to forecast climatic conditions is essential for proper planning in live-stock production. Machine learning (ML) approach leverages on past data to predict future events. Three (3) ML model were built to predict the monthly minimum temperature, maximum temperature, and relatively respectively based on information from the previous 11 months.

The methodology adopted is to treat each prediction task as a supervised learning problem. This involves transforming the time series data (Fig. 14) into a feature-target dataset using auto regressive (AR) technique.

The parameter (temp\_min or temp\_max or relative humidity) to be predicted is set as the target (dependent) variable and in each case be defined by

$$T \min (t)|T \max (t)|RH(t) = f[T \min (t - n), T \max (t - n), RH(t - n)] \quad (1)$$

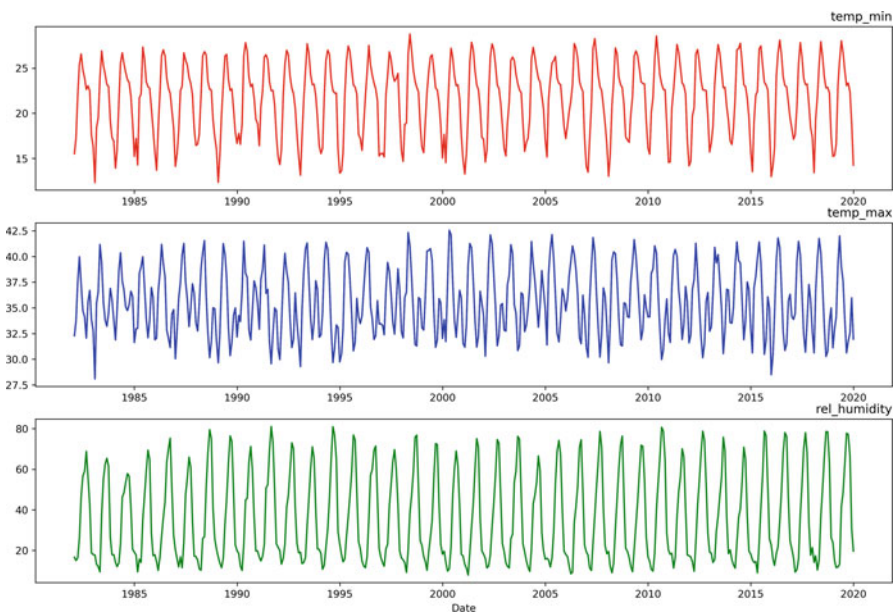
*t* is the prediction date.

*t-n* denotes the time lags, *n* is an integer between 1 and 11

*Tmin(t)*, *Tmax(t)*, *RH(t)* are temperatures and relative humidity to be predicted.

*Tmin(t-n)*, *Tmax(t-n)*, and *RH(t-n)* are minimum, maximum temperatures, and relative humidity, respectively, each time lag.

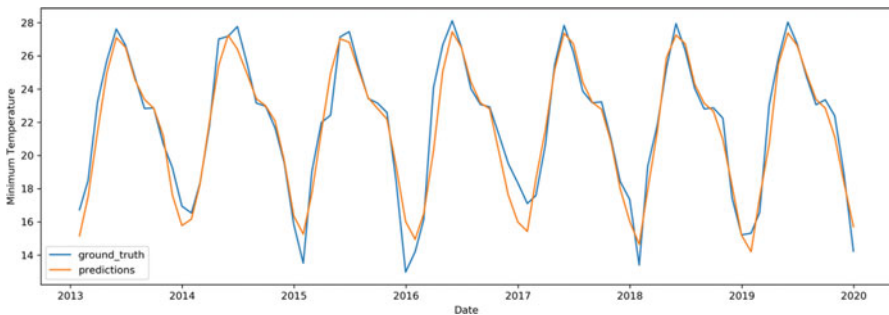
The transformation resulted in a dataset with 445 samples, each with 34 new features. In order to build an ML model, the samples were divided into 361 train



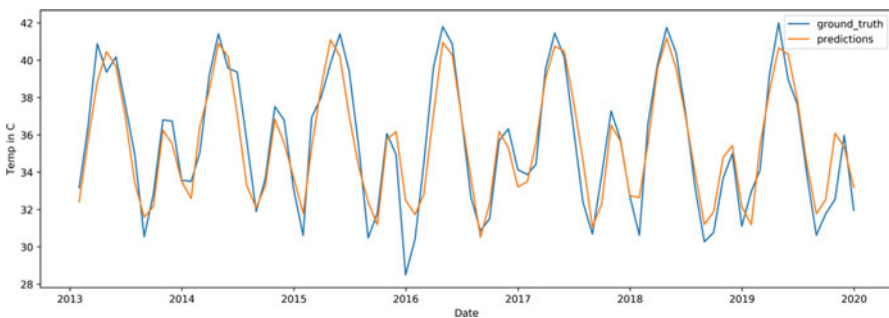
**Fig. 14** Time Series of Temperature and Relative Humidity (1982–2019)

(samples from 1982 to 2012) and 84 validations (samples from 2013 to 2019) sets. The Ensemble machine learning methods which are a stack of multiple learning algorithms were used to train our model. The choice of ensemble algorithm is to obtain better predictive performance than could be obtained from any of the constituent learning algorithms. For the three models that were built, the predictive accuracy measured by the  $R^2$  for minimum temperature, maximum temperature, and relative humidity are 0.9353, 0.8772, and 0.9569 respectively. The plots of the actual prediction and the ground truth for minimum and maximum temperatures and relative humidity are shown in Figs. 15, 16, and 17, respectively.

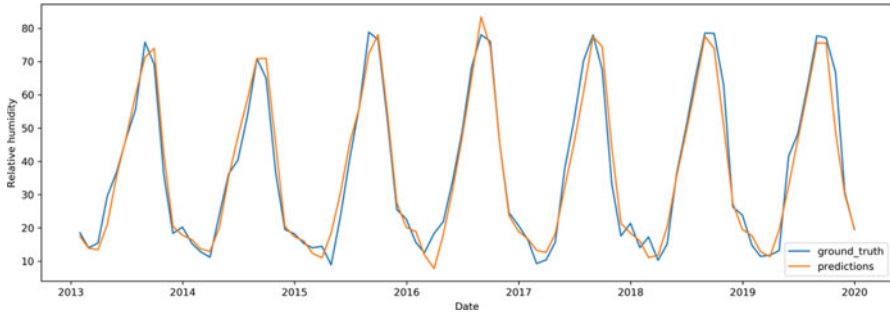
The usefulness of the model developed can be successfully used to predict minimum and maximum temperature as well as relative humidity of Ilela, Sokoto State (representative of Sahel ecoclimate zone). If these predictions are done appropriately, livestock farmers can use the predicted values to calculate temperature humidity index which is indication of level of stress to livestock. Farmers can in essence adjust their management practices accordingly to ensure adequate adaptation in reducing the anticipated stress that may come to their farm animals.



**Fig. 15** Plot of predicted and actual values for minimum temperature for Sahel



**Fig. 16** Plot of predicted and actual values for maximum temperature for Sahel



**Fig. 17** Plot of predicted and actual values for relative humidity for Sahel

## Conclusion and Recommendations

Large proportions of livestock stakeholders in Nigeria are aware of the effect of climate change on livestock production as well as the contributions of livestock production activities to climate change through GHG emissions. About 55% of the respondents agreed that the use of adaptive measures in alleviating the effect of climate change on livestock is capable of reducing its debilitating effect on livestock. The rest of the respondents, about 45%, were either neutral or disagreed with the fact that adaptive measures can mitigate the effect of climate change. It will be necessary to educate those that disagree on this very important fact. About 90% of the respondents however believed that economic, social, health, and environment perspectives are critical to solving the problems of the contributions of livestock production to climate change and global warming. Based on the predictive model developed for temperature and relative humidity in a sample location (Ilela) using Machine Learning in this chapter, there is need for development of a web or standalone application that will be useable by Nigerian farmers, meteorological agencies, and extension organizations as climate fluctuation early warning system. Development of this predictive model needs to be expanded and made functional.

## References

- AbdulKadir A, Usman MT, Shaba AH (2015) An integrated approach to delineation of the eco-climatic zones in Northern Nigeria. *J Ecol Nat Environ* 7(9):247–255
- Adebayo AA, Oruonye ED (2012) An assessment of the level of farmers awareness and adaptation to climate change in Northern Taraba State, Nigeria. In: Proceedings of the 2012 climate change and ICT conference by Centre for Climate Change and Environmental Research, Osun State University, Osogbo
- Adegoke J, Lamptey BL (1999) Intra seasonal variability of summertime precipitation in the Guinea Coastal Region of West Africa'. Paper presented at Cheikh Anta Diop University, Dakar, Senegal, June 1999

- Adesogan AT, Havelaar AH, Mckune SL, Eilitta M, Dahl GE (2020) Animal source foods: Sustainability problem or malnutrition and sustainability solution? Perspective matters. *Glob Food Secur* 25:1–7
- Akande A, Costa AC, Mateu J, Henriques R (2017) Geospatial analysis of extreme weather events in Nigeria (1985–2015) using self-organizing maps. *Adv Meteorol* 2017:11, Article ID 8576150. <https://doi.org/10.1155/2017/8576150>
- Aydinalp C, Cresser MS (2008) The effects of global climate change on agriculture. *Am Eurasian J Agric Environ Sci* 3(5):672–676
- Ayoade JO (2008) Techniques in climatology. Stirling-Horden Publishers Ltd, Ibadan, pp 42–118
- Batima P, Bat B, Tserendash L, Bayarbaatar S, Shiirev-Adya S, Tuvaansuren G, Natsagdorj L, Chuluun T (2005) Adaptation to climate change, vol 90. Admon Publishing, Ulaanbaatar
- Beauchemin KA, McGinn SM (2006) Effects of various feed additives on the methane emissions from beef cattle. *Int Congr Ser* 1293:152–155. <https://doi.org/10.1016/j.ics.2006.01.042>
- Bell MJ, Eckard RJ, Pryce JE (2012) Breeding dairy cows to reduce greenhouse gas emissions, livestock production, Khalid Javed, IntechOpen. <https://doi.org/10.5772/50395> <https://www.intechopen.com/books/livestock-production/breeding-dairy-cows-to-reduce-greenhouse-gas-emissions>. Accessed 25 Sept 2020.
- Berihulay H, Abied A, He X, Jiang L, Ma Y (2019) Adaptation mechanisms of small ruminants to environmental heat stress. *Animals* 9:75
- Bettencourt EMV, Tilman M, Narciso V, Carvalho MLS, Henriques PDS (2015) The livestock roles in the wellbeing of rural communities of Timor-Leste. *Braz J Rural Econ Soc* 53(1):S063–S080
- Biasutti M (2019) Rainfall trends in the African Sahel: characteristics, processes, and causes. *WIREs Clim Change* 10:e591. <https://doi.org/10.1002/wcc.591>
- Brown S (2019) How livestock farming affects the environment. <https://www.downtoearth.org.in/factsheet/how-livestock-farming-affects-the-environment-64218>. Accessed 10 July 2020
- Calvasa C, Chuluunbaatar D, Fara K (2009) Livestock thematic papers- tools for project design. International Fund for Agricultural Development (IFAD) publication. Retrieved from [www.ifad.org/lrkm/factsheet/cc.pdf](http://www.ifad.org/lrkm/factsheet/cc.pdf). Accessed 10 Dec 2015
- Chagunda MGG, Römer DAM, Roberts DJ (2009) Effect of genotype and feeding regime on enteric methane, non-milk nitrogen and performance of dairy cows during the winter feeding period. *Livest Sci* 122:323–332
- Curnow M (2019) Carbon farming: reducing methane emissions from cattle using feed additives. <https://www.agric.wa.gov.au/climate-change/carbon-farming-reducing-methane-emissions-cattle-using-feed-additives>. Accessed 25 Sept 2020
- Dickie A, Streck C, Roe S, Zurek M, Haupt F, Dolginow A (2014) Strategies for mitigating climate change in agriculture: abridged report. Climate focus and California environmental associates, prefaded with the support of the climate and land use Alliance. Report and supplementary materials available at [www.agriculturalmitigation.org](http://www.agriculturalmitigation.org)
- Downing TE, Ringuis L, Hulme M, Waughray D (1997) Adapting to climate change in Africa. *Mitig Adapt Strat Glob Chang* 2:19
- Easterling WE, Aggarwal PK (2007) Food, fibre and forest products. In: Parry ML, Canziani OF, Palutikof JP, Van der Linden PJ, Hanson CE (eds) *Climate change 2007- impacts, adaptation and vulnerability. Contribution of working group II to the fourth assessment report of the intergovernmental panel on climate change*. Cambridge University Press, Cambridge, pp 273–313
- Edwards DC, McKee TB (1997) Characteristics of 20th century drought in the United States at multiple time scales. *Climatology report no. 97-2*, Colorado State University Ft. Collins
- Engelstaedter S, Tegen I, Washington R (2006) North African dust emissions and transport. *Earth Sci Rev* 79:73–100
- FAO (1993) Livestock and improvement of pasture, feed and forage. FAO committee on agriculture, 12th session, item 7, 26 April to 4 May 1993, Rome, 19 pp

- FAO (2006) In: Steinfeld H, Gerber P J, Wassenaar T, Castel V, Rosales M, de Haan C (eds) *Livestock's long shadow – environmental issues and options* Food and Agriculture Organization of the United Nations, Rome
- FAO (2007) *Adaptation to climate change in agriculture, forestry, and fisheries: perspective, framework and priorities*. FAO, Rome
- FAO (2011) *Mapping supply and demand for animal-source foods to 2030*, by Robinson TP, Pozzi F. Animal production and health working paper no. 2, Rome
- Flachowsky G, Kamphues J (2012) Carbon footprints for food of animal origin: what are the most preferable criteria to measure animal yield? *Animals (Basel)* 2(2):108–126
- Gill M, Smith P (2008) Mitigating climate change: the role of livestock in agriculture. In: *Livestock and global change conference proceeding*. May 2008, Tunisia
- Goodland R, Anhang J (2009) *Livestock and climate change. What if the key actors in climate change were pigs, chickens and cows?* Worldwatch November/December 2009, Worldwatch Institute, Washington, DC, pp 10–19
- Hahn GL (1989) Bioclimatology and livestock housing: theoretical and applied aspects. In: *Proceedings of Brazilian workshop on animal bioclimatology*. Jaboticabal, p 15
- Haider H (2019) *Climate change in Nigeria: impacts and responses*. K4D (Knowledge, evidence and learning for development) Helpdesk report. [https://assets.publishing.service.gov.uk/media/5dcd7a1aed915d0719bf4542/675\\_Climate\\_Change\\_in\\_Nigeria.pdf](https://assets.publishing.service.gov.uk/media/5dcd7a1aed915d0719bf4542/675_Climate_Change_in_Nigeria.pdf)
- Henry B, Charmley E, Eckard R, Gaughan JB, Hegarty R (2012) Livestock production in a changing climate: adaptation and mitigation research in Australia. *Crop Pasture Sci* 63:191–202
- Hess HD, Tiemann TT, Noto F, Carulla JE, Kreuzer M (2006) Strategic use of tannins as means to limit methane emission from ruminant livestock. In: *International conference on Greenhouse gases and animal agriculture*, vol. 129, Elsevier International congress series, Zurich, Switzerland, pp 164–167
- Hoffmann I (2008) Livestock genetic diversity and climate change adaptation. *Livestock and global change conference proceeding*. May 2008, Tunisia
- Ickowicz A, Ancy V, Corniaux C, Duteurtre G, Pocard-Chappuis R, Touré I, Vall E, Wane A (2012) Crop–livestock production systems in the Sahel- increasing resilience for adaptation to climate change and preserving food security. Building resilience for adaptation to climate change in the agriculture sector. In: *Proceedings of a joint FAO/OECD workshop* (eds: Meybeck A, Lankoski J, Redfern S, Azzu N, Gitz V). <http://www.fao.org/3/i3084e/i3084e.pdf>
- IFAD (International Fund for Agricultural Development) (2010) *Livestock and climate change*. <http://www.ifad.org/lrkm/events/cops/papers/climate.pdf>
- IFAD (The International Fund for Agricultural Development) (2002) 'The rural poor' in world poverty report. IFAD, Rome
- IPCC (2007a) Summary for policymakers. In: *Climate change 2007: impacts, adaptation and vulnerability. Contribution of working group II to the fourth assessment report of the Intergovernmental Panel on Climate Change*: Parry ML, Canziani OF, Palutikof JP, Van der Linden PJ, Hanson CE. Cambridge University Press, 1000
- IPCC (2007b) *Climate change 2007: mitigation*. In: Metz B, Davidson O R, Bosch P R, Dave R and Meyer LA (eds) *Contribution of working group III to the fourth assessment report of the intergovernmental panel on climate change*. Cambridge University Press, Cambridge, UK/ New York
- Iyiola-Tunji AO (2012) Genetic analysis of growth rate and some reproductive traits of Balami, Uda and Yankasa sheep and their crosses. Unpublished PhD thesis submitted to School of Post Graduate Studies, Ahmadu Bello University, Zaria, Nigeria
- Iyiola-Tunji AO, Annatte I, Adesina MA, Ojo OA, Buba W, Nuhu S, Bello M, Saleh I, Yusuf AM, Tukur AM, Hussaini AT, Aguiri AO (2015) Evaluation of crop-livestock integration systems

- among rural farm families at adopted villages of National Agricultural Extension and Research Liaison Services. *J Agric Ext* 19(2):46–58
- Iyiola-Tunji AO, Adesina MA, Ojo OA, Buba W, Saleh I, Yusuf AM, Tukur AM, Bello M, Nuhu S (2017) Characterization of labour usage, harvest and processing activities among crop and livestock farming households at NAERLS-adopted villages. *Nig J Agric Ext* 18 (1):51–70
- Jäkel D (2004) Observations on the dynamics and causes of sand and dust storms in arid regions, reported from North Africa and China. *Erde* 135:341–367
- Jose S (2009) Agroforestry for ecosystem services and environmental benefits: an overview. *Agrofor Syst* 76:1–10
- Kataria RP (2015) Use of feed additives for reducing greenhouse gas emissions from dairy farms. *Microbiol Res* 6(6120):19–25
- Kebede D (2016) Impact of climate change on livestock productive and reproductive performance. *Livest Res Rural Dev* 28(2). <http://www.lrrd.org/lrrd28/12/kebe28227.htm>
- Kebede A, Tamiru Y, Haile G (2018) Review on impact of climate change on animal production and expansion of animal diseases. *Scholars J Agric Vet Serv* 5(4):205–215
- Khalifa HH (2003) Bioclimatology and adaptation of farm animals in a changing climate. In: Interactions between climate and animal production, European federation of animal science technical series, vol 7. Wageningen Academic Publishers, Wageningen, pp 15–29
- Klop G (2016) Low emission feed – using feed additives to decrease methane production in dairy cows. PhD thesis, Wageningen University, Wageningen, NL. 168 pages. ISBN 978-94-6257-894-4. <https://doi.org/10.18174/387944>
- Kurukulasuriya P, Rosenthal S (2003) Climate change and agriculture: a review of impacts and adaptations. Climate Change series paper no. 91, World Bank, Washington DC
- Lamidi OS (2005) The use of some non-conventional protein sources for fattening cattle. Unpublished PhD thesis submitted to the School of Post Graduate Studies, Ahmadu Bello University, Zaria
- Lawal-Adebawale OA (2012) Dynamics of ruminant livestock management in the context of the Nigerian Agricultural System. Livestock production chapter 4. Intech. pp 62–80. <https://doi.org/10.5772/52923>
- Lindgren J (2019) Reducing Greenhouse gas emissions from cattle production. Friday, October 4, 2019. <https://water.unl.edu/article/animal-manure-management/reducing-greenhouse-gas-emissions-cattle-production>
- McClanahan TR, Cinner JE, Maina J, Graham NAJ, Daw TM, Stead SM, Wamukota A, Brown K, Ateweberhan M, Venus V, Polunin NVC (2008) Conservation action in a changing climate. *J Soc Conserv Biol* 1(2):53–59
- Murphy SP, Allen LH (2003) Nutritional importance of animal source foods. *J Nutr* 133 (11):3932S–3935S
- Myhre G, Samset BH, Schulz M, Balkanski Y, Bauer S, Berntsen TK, Bian H, Bellouin N, Chin M, Diehl T, Easter RC, Feichter J, Ghan SJ, Hauglustaine D, Iversen T, Kinne S, Kirkevåg A, Lamarque J-F, Lin G, Liu X, Lund MT, Luo G, Ma X, van Noije T, Penner JE, Rasch PJ, Ruiz A, Seland Ø, Skeie RB, Stier P, Takemura T, Tsigaridis K, Wang P, Wang Z, Xu L, Yu H, Yu F, Yoon J-H, Zhang K, Zhang H, Zhou C (2013) Radiative forcing of the direct aerosol effect from AeroCom Phase II simulations. *Atmos Chem Phys* 13:1853–1877
- NAERLS (2019) <https://naerls.gov.ng/wp-content/uploads/2020/03/Agricultural-Performance-Survey-of-2019-Wet-Season-in-Nigeria-Executive-Summary.pdf>
- Nardone A, Ronchi B, Lacetera N, Ranieri MS, Bernabucci U (2010) Effect of climate change on animal production and sustainability of livestock system. *Livest Sci* 130:57–69
- Nelson KS, Bwala DA, Nuhu EJ (2015) The Dromedary camel: a review on the aspects of history, physical description, adaptations, behaviour/lifecycle, diet, reproduction, uses, genetics and diseases. *Niger Vet J* 36(4):1299–1317



- Nicholson SE, Palao IM (1993) A re-evaluation of rainfall variability in the Sahel. Part I. Characteristics of rainfall fluctuations. *Int J Climatol* 13(4):371–389
- Nwosu CC, Ogbu CC (2011) Climate change and livestock production in Nigeria: issues and concerns. *Agro Sci J Trop Agric Food Environ Ext* 10(1):41–60
- Ojo O (1977) *The climate of West Africa*. Heineman, London
- Olagunju TE (2015) Drought, desertification and the Nigerian environment: a review. *J Ecol Nat Environ* 7(7):196–209
- Onah NG, Alphonsus NA, Ekenedilichukwu E (2016) Mitigating climate change in Nigeria: African traditional religious values in focus. *Mediterr J Soc Sci* 7(6):299–308. <https://doi.org/10.5901/mjss.2016.v7n6p299>
- Oseni S, Bebe O (2008) Climate change, genetics of adaptation and livestock production in low-input systems. Paper presented at ICID+18 2nd international conference: climate, sustainability and development in semi-arid regions August 16–20, 2010, Fortaleza–Ceará, Brazil and Hoffmann I (2008) Livestock genetic diversity and climate change adaptation. Livestock and global change conference proceeding. May 2008, Tunisia
- Riahi K, Rao S, Krey V, Cho C, Chirkov V, Fisher G, Kindermann G, Nakicenovic N, Rafaj P (2011) RCP 8.5 – a scenario of comparatively high greenhouse gas emissions. *Climate Change* 109:33–57
- Rojas-Downing MM, Nejadhashemi AP, Harrigan T, Woznicki SA (2017) Climate change and livestock: impacts, adaptation and mitigation. *Clim Risk Manag* 16:133–144
- Rowlinson P, Steele M, Nefzaoui A (2008) Livestock and global climate change: adaptation I and II. In: Rowlinson P, Steel M, Nefzaoui A (eds) *Livestock and global climate change conference proceeding*. Cambridge University Press, Tunisia, pp 56–85
- Schmidt MI (2008) The relationship between cattle and savings: a cattle-owner perspective. *Dev South Afr* 9(4):433–444
- Schwanghart W, Schutt B (2008) Meteorological causes of Harmattan dust in West Africa. *Geomorphology* 95:412–428
- Smith JP, Pearce BD, Wolfe MS (2012) Reconciling productivity with protection of the environment: is temperate agroforestry the answer? *Renewable Agric Food Syst* 28(1):80–92
- Srivastava NSL (2006) Farm power sources, their availability and future requirement to sustain agricultural production status of farm mechanization in India. IASRI report, 57–68
- Suleiman M (2017) Sahel region, Africa. *The Conversation Newsletter*. <https://theconversation.com/sahel-region-africa-72569>
- Thomson AM, Calvin KV, Smith SJ, Kyle GP, Volke A, Patel P, Delgado-Arias S, Bond-Lamberty B, Wise MA, Clarke LE, Edmonds JA (2011) RCP4.5: a pathway for stabilization of radiative forcing by 2100. *Clim Chang* 109(1–2):77–94. <https://doi.org/10.1007/s10584-011-0151-4>
- Umar MA, Dalhatu M, Bello A, Nawawi H (2013) Animal traction as source of farm power in rural areas of Sokoto State, Nigeria. *Health Safety Environ* 1(1):23–28
- Umunna MO, Olafadehan OA, Arowona A (2014) Small ruminant production and management systems in Urban area of Southern Guinea Savannah of Nigeria. *Asian J Agric Food Sci* 2(2):107–114
- van de Haar MJ, St. Pierre N (2006) Major advances in nutrition: relevance to the sustainability of the dairy industry. *J Dairy Sci* 89(4):1280–1291
- van Vuuren DP, Edmonds J, Kainuma M et al (2011) The representative concentration pathways: an overview. *Clim Chang* 109:5–31. <https://doi.org/10.1007/s10584-011-0148-z>
- van Zijderveld SM, Fonken B, Dijkstra J, Gerrits WJJ, Perdok HB, Fokkink W, Newbold JR (2010) Effects of a combination of feed additives on methane production, diet digestibility, and animal performance in lactating dairy cows. *J Dairy Sci* 94:1445–1454. <https://doi.org/10.3168/jds.2010-3635>
- Vince G (2012) Sucking CO<sub>2</sub> from the skies with artificial trees. *Future*. BBC Program 4th October, 2012. <https://www.bbc.com/future/article/20121004-fake-trees-to-clean-the-skies>

**Open Access** This chapter is licensed under the terms of the Creative Commons Attribution 4.0 International License (<http://creativecommons.org/licenses/by/4.0/>), which permits use, sharing, adaptation, distribution and reproduction in any medium or format, as long as you give appropriate credit to the original author(s) and the source, provide a link to the Creative Commons license and indicate if changes were made.

The images or other third party material in this chapter are included in the chapter's Creative Commons license, unless indicated otherwise in a credit line to the material. If material is not included in the chapter's Creative Commons license and your intended use is not permitted by statutory regulation or exceeds the permitted use, you will need to obtain permission directly from the copyright holder.





# Corona Virus, Climate Change, and Food Security

# 30

Nkiru Theresa Meludu and Toyin Abolade

## Contents

Introduction .....	564
Conceptualizing the Pandemic Nature of Coronavirus .....	565
Symptoms Associated with COVID-19 (NCDC and Hopkins University 2020; WHO 2020) .....	566
Preventive Measures of COVID-19 .....	567
Strategies Implemented by the Government Globally to Control and Prevent the Spread of COVID-19 .....	567
Diagnosis of COVID-19 .....	568
Transformation of Situations Causing Typical Climate Change .....	568
Effects of Weather Variation on the Environment and Agriculture in Nigeria .....	569
Effects of Climate Change on Food Security .....	570
Concepts of Food Security .....	571
Food Insecurity .....	572
Effects of the Coronavirus 2019 (COVID-19) Pandemic and Climate Change on Food Security .....	573
Empirical Evidences Obtained Through Online Survey on COVID-19 Awareness and the Effect on Food Security .....	574
Conclusion .....	576
Recommendation .....	577
References .....	577

This chapter was previously published non-open access with exclusive rights reserved by the Publisher. It has been changed retrospectively to open access under a CC BY 4.0 license and the copyright holder is “The Author(s)”. For further details, please see the license information at the end of the chapter.

N. T. Meludu (✉) · T. Abolade  
Department of Agricultural Economics and Extension Faculty of Agriculture, Nnamdi Azikiwe University, Awka, Nigeria  
e-mail: [nt.meludu@unizik.edu.ng](mailto:nt.meludu@unizik.edu.ng)

---

**Abstract**

Coronavirus disease of 2019 (COVID-19) is a current pandemic causing lockdown of cities and countries. The nature of this disease and the global cases are still considered as deadly all over the world. Analogous was drawn between the current COVID-19 pandemic and some of the other contemporary crises of the world as regards to climate change in addition to food shortage. Also, Survey Monkey instrument was used to generate empirical evidences from 514 respondents on covid-19 awareness and the effect on food security. Effects of diseases on climate change, such as the increasing frequency and strength of extreme weather events or the expanding range and spread of diseases was considered. Then, the relationship between the COVID-19 pandemic and climate change was investigated. Prior to the pandemic, climate change already had adverse effects on agriculture and vice versa, which led to food insecurity. The need for fruits as well as leafy and root vegetables in peri-urban and urban areas is increasing, as well as the food shortage. A drop in agricultural production will be expected in the future if the pandemic continues for a few more months. The perception and adherence to the preventive measures for this pandemic were determined to reduce its spread and lessen its effect on agricultural production as well as to improve food security.

---

**Keywords**

Covid-19 · Climate outcomes · Consequences · Agriculture · Food insecurity

---

**Introduction**

A total of 17 sustainable development goals (SDGs) have been set to transform our world, namely: no poverty, zero hunger, good health and well-being, quality education, gender equality, clean water and sanitation, affordable and clean energy, decent work and economic growth, industry, innovation and infrastructure, reduced inequality, sustainable cities and communities, responsible consumption and production, climate action, life below water, life on land, peace and justice strong institutions, partnership to achieve the goals (United Nations Department of Economic and Social Affairs (UNDESA) 2015).

**SDGs** are the organized principles for addressing environmental improvement objectives and sustaining the capacity of the usual structure to offer natural resources, flora and fauna services upon which the economy and humanity depends is crucial.

This chapter identified some of the issues influencing climate change and the effect of climate change on food security. It also discussed coronavirus disease 2019 (COVID-19), which is the current pandemic causing lockdown of the entire economy due to its global occurrence (World Health Organisation (WHO) 2020). Some

empirical evidences were determined with the use of “Suervey Monkey” Instrument that generated responses from respondents from different parts different of Nigeria at the peak of the pandemic. This chapter highlighted the pandemic nature of COVID-19 and other hidden evidences in litreature. Essentially, some of the health constraints on climate change include the increasing occurrence of extreme weather events and the growing rate and spread of illnesses, such as malaria.

**COVID-19**, a persistent respiratory disease caused by corona virus is transmitted chiefly by contact with human and infected surfaces and the individual shows symptom of fever, cough, and shortness of breath and may advance to pneumonia, respiratory failure and death.

Furthermore, the relationship between pandemic and climate change was investigated, although climate change already had adverse effects on agricultural production, which led to food insecurity, especially in under developed countries. It is expected that agricultural production will drop in the subsequent years if COVID-19 pandemic persists for more months. The vulnerable groups include small-scale farmers, migrants, labourers/workers, nomads, and fisher folks who have been prevented from working on their farms and from taking care of their animals/fisheries will fell the effect. These groups also face difficulty in obtaining access to proper marketplaces to retail their produces and processed goods as a result of increased food prices and inadequate purchasing resources. Informal laborers are also affected leading to hike in labor cost and income losses because of delayed harvesting of the produce.

---

## Conceptualizing the Pandemic Nature of Coronavirus

COVID-19 could be described as a respiration set of severe acute respiratory syndrome coronavirus 2 (SARS-CoV-2) (World Health Organization (2020)). This virus spreads primarily between people during close contact, often through small drops of discharge from the nostrils once an infested individual sneezes or coughs into the air. The droplets usually drop to the ground/surfaces without being suspended in the air moving 2-m distances (Nigerian Centre for Disease Control (NCDC) 2020). People may contract the virus by touching polluted surfaces and then touching their faces (mouth, nose, and eyes). The first case of COVID-19 occurred in December 2019 in Wuhan, China’s Hubei Province. Then, it subsequently spread globally, which resulted in the ongoing 2019–2020 coronavirus pandemic (Hui et al. 2020; World Health Organization (WHO) 2020). COVID-19 has an incubation period of usually 2–14 days for people who develop symptoms; however, some people who are infected do not develop any form of symptoms and are thus called asymptomatic. While it is easy to isolate and treat infected people that develop symptoms, the asymptomatic patients cannot be easily identified, isolated, and treated, thus posing a great risk of spreading of the virus. This brings fear to the people and also has crippled many economies worldwide, affecting agricultural

production, thus causing food scarcity, hunger, and food insecurity. Interestingly, researchers worldwide are working tirelessly to develop vaccines/drugs and treatment regimes of the disease.

---

### **Symptoms Associated with COVID-19 (NCDC and Hopkins University 2020; WHO 2020)**

1. Cough – Coughing is a common impulse action that clears the throat of mucus or foreign irritants. While an individual coughs to free the throat at intervals, some amount of situations can lead more frequent coughing, which could be as a result of Covid-19.
2. Loss of appetite – This is referred to as anorexia and could be caused by a diversity of conditions and diseases. Some of these conditions could be temporal and rescindable, such as defeat of appetite or a side effect of medicine. Majority of the situations could be very severe, for instance, the consequences of disease causation (could be covid-19). Continuous absence of hunger should be evaluated by a healthcare professional.
3. Difficulty in breathing – This could be described as uneasiness and could be related to numerous diverse conditions. It is important to note that frequent incidents of shortness of breath could be a symptom of a severe illness (such as Corona virus) that needs attention.
4. High temperature/fever – The common body temperature is different for many people and changes during the day. If the body temperature is 38 °C, it is considered as a high fever. Several conditions could lead to fever, but it is usually caused by the body fighting an infection (may be covid-19).
5. Sneezing – This is a sudden reflex discharge of air from the nose and mouth due to irritation of the nostrils, which is caused by exasperation to the mucous membranes of the nose or throat. It may be very inconvenient and could be symptom of Corona virus.
6. Headache – Pain which occurs along the nerves, blood vessels, and muscles that is felt in the head. However, if it persists for 3 days, the doctor should be contacted because it could be an indication of an underlying disease.
7. Fatigue – This could be bodily, mental, or both, an indication which could be difficult to describe; however, words like tired, exhausted, and worn-out may be used.
8. Joint pains – This refers to the uneasiness and pain felt in some joints of the body, such as those of the shoulders, hips, elbows, and knees. Occasionally, joint pain is a result of an illness or injury.
9. Runny nose – This is an indication of several health situations resulting in the flow of secretion from the nostrils. This secretion protects material generated from the slimy tissue that lines the nasal cavity, which mixes with the saliva and drips down the back of the throat.

10. Sore throat – This is caused by a virus-related contamination, such as cold or influenza. It is also very important that symptoms are appropriately observed.

---

## **Preventive Measures of COVID-19**

There are preventive measures recommended to prevent COVID-19 infection, such as self-isolation when feeling sick; avoiding busy spaces; practicing good hygiene; proper handwashing; using alcohol-based sanitizers; maintaining social and physical distancing from others, especially those with symptoms; covering mouth while coughing and sneezing with tissues, which should be thrown properly in a closed dustbin; and preventing from touching the face with unwashed hands. Furthermore, mask should be used outdoor, where additional non-pharmaceutical techniques cannot be adhered, to reduce the rate of transmission (NCDC 2020; WHO 2020).

---

## **Strategies Implemented by the Government Globally to Control and Prevent the Spread of COVID-19**

1. Total and partial lockdown for weeks or months of states/regions affected by COVID-19
2. Enforcement of curfew between certain hours of the day to prevent people from going out and contracting the disease
3. Closure of the country/state borders (land, air, and waterways) to prevent further spread of the disease
4. Banning of the interstate movement
5. Fumigation of public places with disinfectants (marketplaces, parking areas, hospitals, congested areas, roads, etc.)
6. Enforcement of the use of surgical gloves, medical masks for healthcare givers, and fabric masks for non-medical personnel
7. Restriction of people's movements to only essential services (healthcare workers, security personnel, and journalists)
8. Opening of markets for some days of the week
9. Distribution of palliatives to the poorest of the poor in the country to enable citizens to fully comply with the total lockdown

However, some of the measures implemented to prevent the spread of the virus, such as fumigation of public spaces with chemicals and the use of personal protective equipment (PPE), which are not properly disposed, can lead to land, water, and air pollution, which will later negatively affect the environment, possibly resulting in environmental challenges and food insecurity and these could be worst in less-developed countries.

## Diagnosis of COVID-19

The seriousness of the pandemic differs from person to person. COVID-19 infection could show minor symptoms, such as ordinary flu or common cold, or no symptoms at all. As the infection progresses, the symptoms change based on gender, generational, and the type of underlying illness. People with mild symptoms of COVID-19 infection usually get better in 14 days or less, although it takes 21 to 30 days to achieve full recovery (NCDC 2020; WHO 2020). Older people or those with underlying diseases, such as hypertension, diabetes, cardiovascular diseases, chronic respiratory diseases, and cancers of any type, are susceptible to this infection (NCDC 2020), while children experience less severe symptoms. The mortality rate of adults less than 50 years who were infected with COVID-19 is less than 0.5%. Conversely, those older than 70 years had the highest mortality rate from the disease. The major problems related with COVID-19 include sepsis, excessive clotting, and damage to the vital organs in the body. Up to 30% of the individuals infected with COVID-19 exhibited elevated liver enzymes, known as *transaminases* (Sanders et al. 2020), resulting in organ failure and eventually death.

---

## Transformation of Situations Causing Typical Climate Change

Climate change is described as variation on usual climate conditions of an area across periods due to natural circumstances or artificial activities causing degradation of the environment (Nwosu 2012). Climate change is considered as a long-term shift in the average weather situation of a region, such as its typical temperature, rainfall, and wind patterns. This variation in weather indicates that the consequences estimated in a lot of countries will vary over the coming decades.

Weather variations are global phenomenon of climate transformation characterized through fluctuations observed on weather of the planet regarding temperature and precipitation, which are especially instigated through human activities (Food and Agriculture Organisation (FAO) 2002). The balancing of the weather condition to sustain ecosystems is under threat, as well as the future of humanity and the steadiness of the world economy.

In other words, climate change refers to the deviation in the geometric distribution of the average weather circumstances over a prolonged period of time. Climate change induces an increase in the occurrence of extreme weather events. The characteristics of weather variation poses risks to agricultural sustainability and results in food shortage, high level of poverty, and low level of human and physical development. Uninterestingly, weather variations negatively affect human health, water resources, land use, coastal infrastructure, and the environment (International Fund for Agricultural Development (IFAD) 2010), particularly in developing countries, such as Nigeria, where irrigation is not often practiced, as well as in regions that experience heavy rainfall, thus causing extreme flooding and leaching.



Thus, the apprehension of weather variation cannot be overemphasized which is based on the biggest problem facing the world, affecting everything and everyone, due to the fact that it plays an important environmental influence on ecosystem. Climate change affects the ecosystems in numerous ways, and intermingles with poor growth. The cumulative impacts could lead to intense environmental variations (United States Global Change Research Program (USGCRP) 2009). The severity and frequency of diseases are often related with unfavorable weather conditions and unpredicted health concerns spreading in regions where they have not occurred before.

The consequences of weather variation on the availability, accessibility and stability of food supplies can cause major alterations in people's diet choices, which in turn have consequences on the health of the households and low recovery rate from the pandemic.

Nelson et al. (2018) has reported that climate change is expected to alter global nutrient availability, thereby exerting aftermath effects on malnutrition. The increasing CO<sub>2</sub> levels are also expected to reduce the levels of proteins, iron, zinc, and vitamins B1, B2, B5, and B9 in staple foods and docosahexaenoic acid content of fish, which will cause malnutrition to millions of people worldwide after the COVID-19 pandemic (Colombo et al. 2019). COVID-19 pandemic and devastating consequences, and how to stop its spread have become the focus of the world. The greenhouse gases (GHGs) that significantly contribute to climate change, include carbon dioxide, methane, nitrous oxide, ammonia, and other trace gases (Intergovernmental Panel on Climate Change (IPCC) 2007). The other factors causing weather variations are natural causes and human activities. Human activities, such as fumigation and disinfection of public places and improper disposal of used PPEs during the COVID-19 pandemic, also immensely contribute to climate change. The scorching of fossil fuels and the conversion of land for forestry to other uses, including agriculture, are also examples of human activities. Conversely, the natural causes of climate change include variations in ocean currents and atmospheric circulation.

---

## **Effects of Weather Variation on the Environment and Agriculture in Nigeria**

The effects of weather variation on food production differ from one country to another which is dependent on the current climate condition affecting agricultural productivity differently. Nigeria, like all the other countries in the sub-Saharan Africa, is highly vulnerable to the impact of climate change. Climate change variations from 1960 and 1999 in parts of Nigeria presented visible incidences of deficiency for a cumulative period of approximately 8–18 years in some parts of Nigeria (Obioha 2009; Muhammed et al. 2011). Uncertainties about the farming season due to the changes in rainfall pattern resulted in crop failure, thus leading to food shortages because of poor harvests. An increase in rainfall is also favorable for

the outbreak of pests and crop diseases, which is detrimental to crop production. Specifically, pests and crop diseases are visible in response to weather variation, which hypothetically threaten livestock in the drier northern states of Nigeria (Food and Agriculture Organisation (FAO) 2002). Small-scale farmers face the problem of flooding, which destroys the infrastructure used to store or transport food from production areas to markets, thereby discouraging the farmers to produce more food (Aluko et al. 2008). Global warming also negatively affects the seafood and aquatic lives that are important to humans. In addition, climate change affects not only food security but also the livelihood of the people, thus obstructing the advancement of many developing and underdeveloped countries. It is quite obvious that the most serious challenge to agricultural production and mankind worldwide, especially in Africa, is climate change.

---

### Effects of Climate Change on Food Security

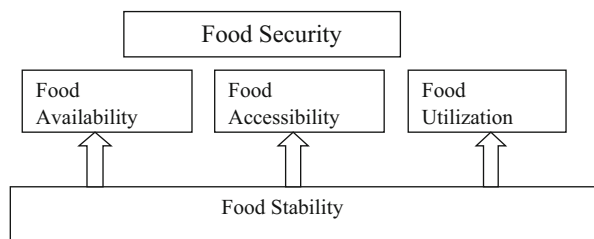
African countries that rely solely on natural resources and rainfed agriculture are more vulnerable to the risks of climate change (IFAD 2010). The consequences of climate change effects are irreversible, potentially disastrous to the entire nation, most especially the developing and underdeveloped nations. For example, it was estimated that by 2020, agricultural production would decline by 50% in some countries with rainfed agriculture (Nanki et al. 2010), and this will be worsened by the COVID-19 pandemic. The Intergovernmental Panel on Climate Change (IPCC) in 2008 analyzed that a temperature increase of 2.5 °C would result in a loss of 1.0–1.5% of the gross domestic product (GDP) in developed countries and 2–9% in developing countries. Generally, climate change causes floods, droughts, or tropical storms, which can take a major toll on a country's economy if a significant part of economic activity is sensitive to the weather and climate. Therefore, if the current trend of GHG emissions continues, the per capita GDP loss by 2022 will be as much as 3–35% (Tamirisa 2008; Harris et al. 2017). Africa is a good example of the influence of climate variability on a developing country's economy (USAID 2010; Zenebe et al. 2011). Boko et al. (2007) and IFAD (2010) reported that the rainfed agriculture and pastoral communities in Africa are dependent on annual rain and were identified to be more susceptible to the effects of climate change. Climate change have negative impacts on food production, especially livestock, in terms of CO<sub>2</sub> and methane emissions. Livestock uses about 32% of arable land, and cattle rearing causes up to 70% of land degradation and pollution. Therefore, if forests are lost, it will be difficult to fight climate change (Meludu 2019). The sheer quantity of animals being raised for human consumption is a threat to climate sustainability. Another scenario is that 1 ha of land for beef production will feed one person, the same hectare for rice production will feed 19 persons, and the same hectare for potato production will feed 22 persons. This competition is too high to achieve food security and eradicate poverty due to degradation and pollution.

## Concepts of Food Security

Food security exists at all periods with individuals having financial access to necessary, harmless, and nutritious food that provides adequate requirement for sustainable life expectancy (FAO 2002; Meludu 2009; Meludu and Ewebiyi 2010). Food security and food insecurity are considered to be dynamics that depend solely on causes of not having enough food and the management. However, the partial and total lockdown implemented worldwide due to the COVID-19 pandemic has affected numerous economic activities, such as food distribution, restaurants, hospitality industries, and transportation activities. During the COVID-19 pandemic, many countries closed their borders, preventing the free flow of goods in to different countries and even within the cities. This restriction caused constraints in food distribution and food hoarding, which posed great challenges to food security. This is especially to the vulnerable population including; aged people (senior citizens), children, pregnant women and those with immune-compromised status. Due to the pandemic, food prices have increased worldwide; staple foods such as wheat, *garri*, rice and beans, tubers, meats, fruits, and vegetables became expensive. Adequate and effective support to encourage unhindered transportation of food items from source locations to various destinations, home deliveries became necessary to reduce human interactions and prevent the possibility of getting infected. When food security is compromised, the consequence is food insecurity.

Food accessibility is affected by the production, distribution, and stability of food (Fig. 1). Food accessibility refers to the easy access to food that is essential to combat hunger and overcome food insecurity. An individual or household's access to food can be influenced by their income and health conditions. Consumers must be able to have the purchasing power in order to have access to food. Due to the COVID-19 pandemic, the rate of unemployment has increased, which resulted in food insecurity. Individuals need to eat sufficiently to develop strong immunity against the virus and to be physically healthy to be able to digest and utilize the nutrients in the food consumed. Food utilization can also be influenced by nutritional values, health status of an individual, safety of the food, and how it is prepared before consumption. Food will be well utilized when people strictly adhere to the important safety precautions against COVID-19. Food stability is guaranteed if the governments worldwide make adequate preparations to reduce the rate of

**Fig. 1** Dimension of food security. (Source: Francesco et al. (2011))



postharvest losses to make food available during this pandemic so that people will remain healthy and safe.

Therefore, to achieve all the highlighted dimensions of food insecurity, the pandemic should be dealt with accordingly to reduce its impacts on climate change so as to avoid food shortage. If adequately managed, the resultant effects will reduce the occurrence of food insecurity globally.

---

## Food Insecurity

Food insecurity could be considered as deficiency in access to adequate food amount in terms of quality and quantity. Inadequate diet and reduced immune system amplify vulnerability to diseases (Meludu 2011). Low diet is correlated with the increasing development of non-communicable diseases (NCDs) (Velmurugan et al. 2017).

Climate change-related incidents recurring everyday requires immediate action (Solly 2019). Therefore, a scientific innovation strategy for mitigating the impacts of climate change on agricultural systems is important. Increased food traceability aimed at preventing food loss due to contamination issues, prediction of extreme events is very german at this period of pandemic (Dhaliwal and Williams 2019; Fabregas et al. 2018; Nkurunziza et al. 2019).

Food contamination caused by climate change also threatens the achievement of the SDGs, namely SDG 2 (zero hunger), SDG 3 (good health and well-being), SDG 8 (decent work and economic growth), SDG 12 (responsible consumption and production), and SDG 13 (climate action) and indirect effect on the other SDGs. Labor scarcities impacted producers, processors, traders, and distribution companies in food distribution chains necessitate workforces to be in near vicinity. The United Nations World Food Programme (UNWFP) predicted that approximately 265 million people will experience increased food insecurity by the end of 2020.

Food insecurity can be illustrated by durations such as; chronic food insecurity is a long-standing food scarcity. Temporary food insecurity is a momentary circumstance of food insecurity where a populace agonizes from food insecurity transition at the time there is an unexpected drop in the capability to produce food for adequate nutritional status and lastly, Seasonal food insecurity is a condition that could happen from time to time.

Food insecurity “hot spots” according to the UNWFP include the following:

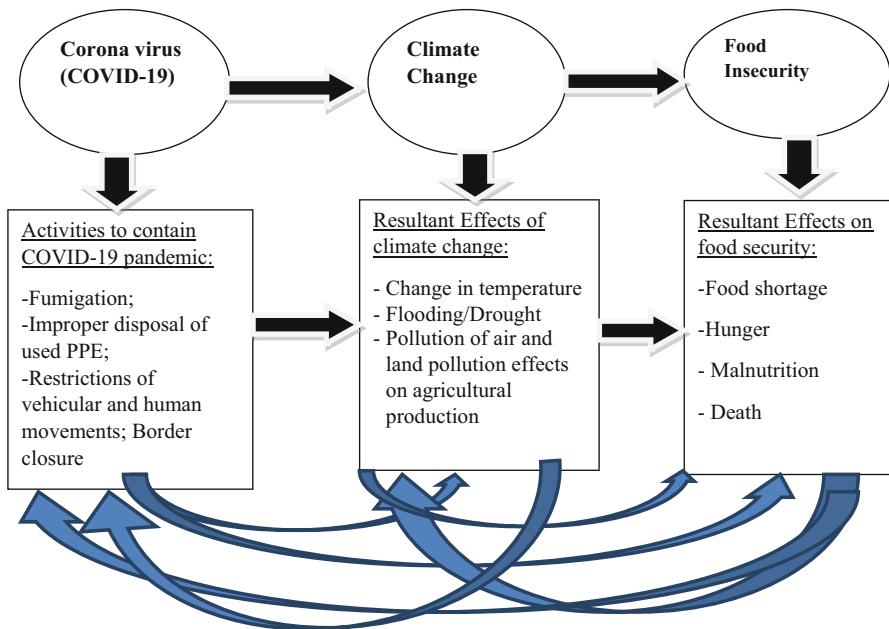
- Substantial conflict-affected states, where food supplies are problematic due to the pandemic. The Fulani nomads are also moving due to climate change which is destroying crops and agricultural land. Uninterestingly, many farmers and their families are displaced from their communities and killed
- Countries experiencing numerous emergencies due to climate change consequences that affect food production worldwide, accompanied by the high incidence of flood preventing farmers from going to their farms to plant

- Vulnerable individuals constantly experiencing food insecurity even before the pandemic
- Countries with significant currency depreciation and other product price failure (dropping the volume to import food)

### Effects of the Coronavirus 2019 (COVID-19) Pandemic and Climate Change on Food Security

The COVID-19 pandemic has negative effects on climate change which lead to food insecurity. The process of fumigating public places (markets, churches, parking areas, offices, and the entire environment) pollutes the air which eventually affects the weather condition (Fig. 2).

COVID-19 has caused a dramatic loss of human lives worldwide. It also presented an unprecedented challenge with deep social and economic consequences, including food insecurity and malnutrition. An impact on the crusade of labor force and the distribution of inputs has also caused unacceptable constraint to food production. However, agriculture and food-related logistic services was considered to be among the important concerns during the COVID-19 pandemic; thus, food production and distribution should not be compromised.

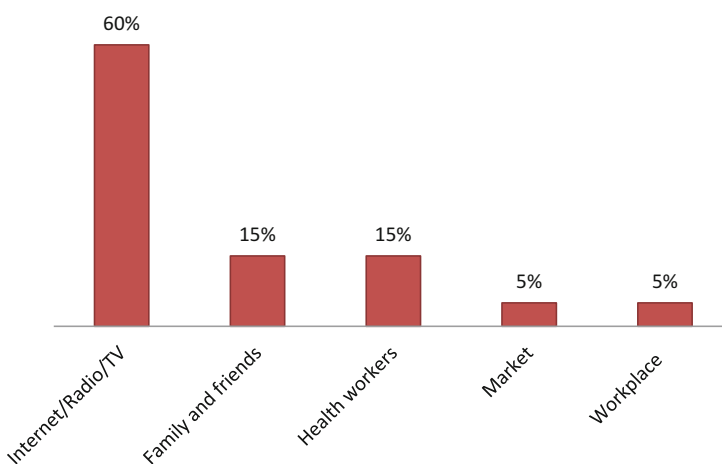


**Fig. 2** Conceptual framework of the interface between COVID-19, climate change, and food security

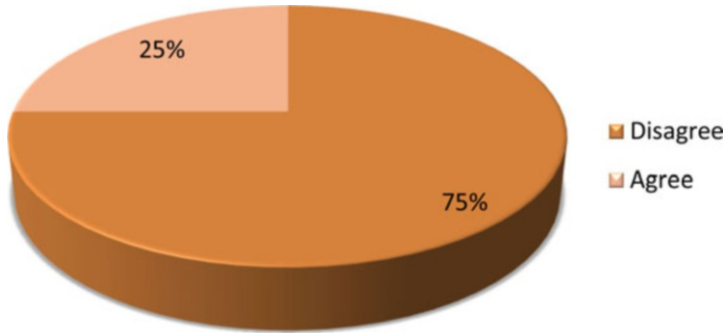
The government in every country adopted the idea of lockdown as part of the precautionary measures to stop the spread of COVID-19 among its citizens. On the contrary, this lockdown resulted in food shortage in that farmers, marketers, processors, and other stakeholders in the value/supply chain were unable to carry out their enterprise characteristics and the global food system has been destroyed.

### Empirical Evidences Obtained Through Online Survey on COVID-19 Awareness and the Effect on Food Security

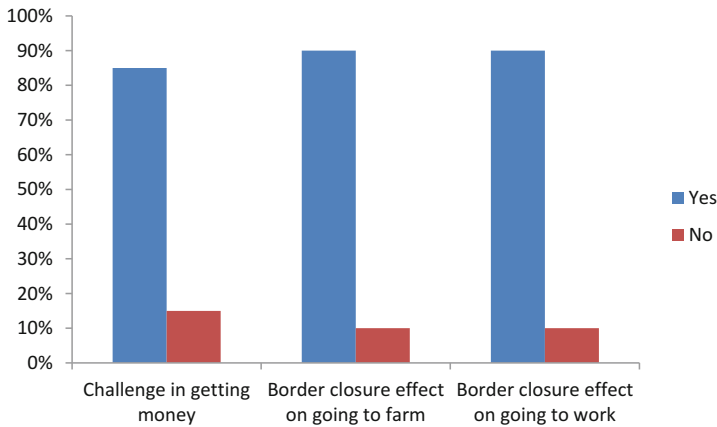
This study used SurveyMonkey (Monkey Survey 2020) to obtain answers to selected questions that were raised with regard to the effects of the COVID-19 pandemic on farming and food security. This study included 514 agricultural stakeholders as participants, of which 55.6% are male and 44.4% are female. It is so disappointing to note that many of these participants (45%) were not taking COVID-19 very seriously, and some were even unsure whether this disease is real or not. They considered it as politicians or rich man disease. This resulted in non-adherence to the safety measures implemented by the government, thereby causing the rapid spread of the disease. About 60% of the respondents learned of this pandemic through radio, television, and Internet, 15% from healthcare workers, 15% from family members, 5% from market places, and 5% from workplaces. This implies that many farmers did not have access to information and communications technologies (Fig. 3) or regular power supply. Thus, only a few people who had sufficient information were able to take adequate measures. This will cause many people to contract the virus, thereby leading to death and affecting agricultural activities which causes food insecurity.



**Fig. 3** Channel of information on the COVID-19 pandemic



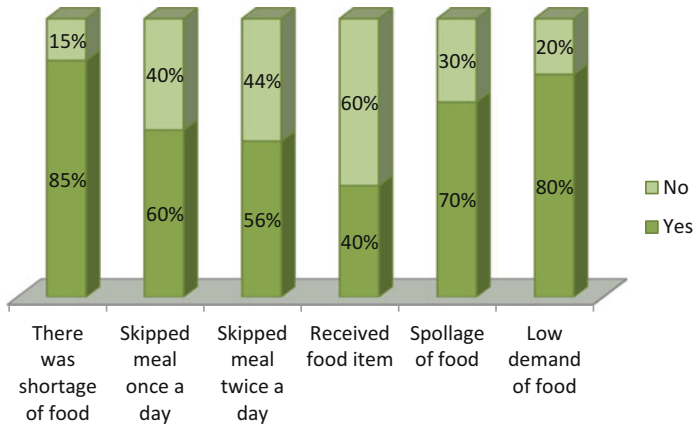
**Fig. 4** Farmers’ access to palliatives



**Fig. 5** Effect of COVID-19 on access to money, farm, and office work

During the period of the lockdown to contain COVID-19, when all economic activities were put on hold, many industries could not pay the salaries of their workers; thus, there was either a pay cut or staff layoff. Due to this, the purchasing power was affected and food accessibility became difficult to achieve. Majority (75%) of the respondents disagreed with the way the government handled the palliative distribution as not everyone was given, especially the farmers, whereas less than average (25%) agreed (Fig. 4).

Farmers that were supposed to be on the farm working were asked to stay home as one of the measures to prevent them from contracting the disease. Almost all (90%) the farmers adhered to this, and 85% did not have access to money (Fig. 5). Most crop and livestock farmers in the developing countries rely solely on rainfed agriculture, whereas only few depend on irrigation. Unfortunately, the peak of COVID-19 occurred at the beginning of the rainy season, which is in April. The farmers were unable to perform their seasonal farming activities. Eventually, this will result in food shortage and food insecurity. Transport route blockage hinders the



**Fig. 6** Distribution of the shortage of food, skipping of meals, food gift, spoilage of agricultural produce, and low demand for food

distribution of fresh goods; thus, high levels of postharvest loss and waste may be experienced.

Marketers play significant roles in ensuring adequate distribution of food products. During the pandemic, marketers were also asked to stay home for a period of weeks or months, depending on the number of index cases recorded in the region. During this period, marketing activities were disrupted as marketers could not buy or sell food as expected. Moreover, there were no available buses/trucks to transport goods and services; interstate borders were also closed. During this, food accessibility was a major challenge for households, thus, eventually leading to food insecurity. Processors are another category of people involve in food distribution. Due to lockdown, the raw materials used for food processing were not available. Therefore, much of foods processing/income were not achieved. This invariably resulted in food shortage and food insecurity and resulted in many (85%) households not having access to food. A high percentage of households reported skipping food once (60%) or twice (56%) a day (Fig. 6). Some crops are supposed to be harvested before the rain in flood-prone areas. However, due to the pandemic, they were left on the ground to spoil (70%). These measures also resulted in labor shortage which disrupted the production and processing of food, most especially for labor-intensive crops. Migrant workers left to their states, and those who stayed were not allowed to come out, which led to high labor cost even after the relaxation of some measures.

## Conclusion

Climate variation causes events that affect many economies and has been linked to poor food production even before the pandemic. Thus, more effects were felt as part of the pandemic consequences, which led to food shortages. Lockdown and closure of borders led to farm labor shortage and increase in food prices. In addition, the



amount of food that would have been produced by farmers reduced. Crops harvested by the farmers and ready for sale got wasted on the farm due to the movement restrictions. There were also few trucks available for transporting produces and food products, which led to an increase in transportation costs. Many low-income households, especially in the rural areas, could not afford to buy enough food to sustain the family, thereby causing hunger and malnutrition and lowering their immunity, which made them susceptible to diseases. This pandemic has affected the sustainable development goals toward achieving food security, namely, goal 1: no poverty, goal 2: zero hunger, goal 3: good health and well-being, goal 4: quality education, goal 5: gender equality, goal 6: clean water and sanitation, and goal 7: achieving human development goals and sustaining the ability of natural system to provide natural resources and ecosystem services by 2030.

---

## Recommendation

Timely and effective policies should be implemented to prevent more effects on climate variations and also to reduce the consequences of COVID-19 so that extreme poverty and hunger can be avoided. To overcome challenges on food price, an adequate price control mechanism and a price monitoring system for food produce must be in place to evaluate the actions. Quality supervision of food items by the appropriate organs of the government is very important in ensuring food safety and quality, especially during and after the pandemic. Countries are encouraged to produce their own agricultural products. People are now advised to engage in agriculture to reduce the effect of the pandemic on food security.

---

## References

- Aluko AP, Oyeleye B, Sulaiman ON, Ukpe IE (2008) Climate change: a threat to food security and environmental protection. In: Proceedings of the 32nd annual conference on forestry Association of Nigeria
- Boko M, Niang I, Nyong A, Vogel C, Githeko A, Medany M, Osman-Elasha B, Tabo R, Yanda P (2007) Climate Change 2007: impacts, adaptation, and vulnerability. In: Parry ML, Canziani OF, Palutikof JP, van der Linden PJ, Hanson CE (eds) Contribution of working group II to the fourth assessment report of the Intergovernmental Panel on Climate Change. Cambridge University Press, Cambridge, UK, pp 433–467
- Colombo SM, Rodgers TFM, Diamond ML, Bazinet RP, Arts MT (2019) Projected declines in global DHA availability for human consumption as a result of global warming. *Ambio* 37:1–16
- Dhaliwal DS, Williams MM (2019) Optimum plant density for crowding stress tolerant processing sweet corn. *PLoS One* 14(9):e0223107. [online]. Accessed 25 May 2020
- Fabregas N, Lozano-Elena F, Blasco-Escamez D, Tohge T, Martinez-Andujar C, Albacete A, Osorio S, Bustamante M, Riechmann JL, Nomura T, Conesa A, Alfocea FP, Fernie AR, Canno-Delgado AI (2018) Over expression of the vascular brassinosteroid receptor BRL3 confers drought resistance without penalizing plant growth. *Nat Commun* 9(1):4680
- FAO (2002) Report of the world food summit five years after. FAO, Rome
- Francesco B, Jessica F, Emile F (2011) The role of food and nutrition system approach in tackling hidden hunger. *Int J Environ Res Public Health* 8:358–373

- Harris JM, Roach B, Anne-Marie C (2017) The economics of global climate change. A GDAE Teaching Module on Social and Environmental Issues in Economics. Global Development and Environment Institute, Tufts University Somerville
- Hui DS, Azhar E, Madani TA, Ntoumi F, Kock R, Dar O (2020) The continuing 2019-nCoV epidemic threat of novel corona viruses to global health. *Int J Infect Dis* 91:264–266
- IFAD (2010) Livestock and climate change Livestock. The International Fund for Agricultural Development (IFAD) Livestock Thematic Papers. <http://www.ifad.org/lrkm/factsheet/cc.pdf>. Accessed 9 Aug 2013
- IPCC (2007) Summary for policymakers. In: Solomon S, Qin D, Manning M, Chen Z, Marquis M, Averyt KB, Tignor M, Miller HL (eds) *Climate change 2007: The physical science basis. Contribution of working group I to the fourth assessment report of the Intergovernmental Panel on Climate Change*. Cambridge University Press, Cambridge, UK/New York
- Meludu NT (2009) Food insecurity and nutritional status of children in rural households (A case of Iddo LGA, Oyo State). *Niger J Soc Work Educ* 8:40–60
- Meludu NT (2011) Farmers' awareness and utilization of disaster management strategies and training needs for sustainable food security and livelihoods in Nigeria. In: Brebbia CA, Kassab AJ, Divo EA (eds) *Disaster management and human health risk II: reducing risk, improving outcomes*. WIT Press, Southampton/Boston, pp 303–319
- Meludu NT (2019) Communicating knowledge of climate change in achieving zero hunger – sustainable development goal (SDG). Paper presented at the one day media round table discussion to the University on Communicating Knowledge on Climate Change Information for Sustainable Decision Making in Nigeria. By Centre for Sustainable Development Nnamdi Azikiwe University, Awka May, pp 1–4
- Meludu NT, Ewebiyi IO (2010) Policy development and opportunities in ICT for sustainable food and nutrition security in Nigeria. *Afr J Psychol Stud Soc Issues* 13(1):137–151
- Monkey Survey (2020) Survey Monkey, San Mateo, pp 1–23. <http://www.surveymonkey.com>. Accessed 5 May 2020
- Muhammed G, Jaliye MM, Usman S, Baniwa E (2011, March) Adaptive strategies to climate change variability and change in rural communities. In: *Proceedings of the 16th annual national conference of agricultural extension of Nigeria (AESON)*
- Nanki K, Million G, Beneberu S, Zegeye T, Gebeyehu S, Endale A (2010) Adapting to climate change in the water sector: assessing the effectiveness of planned adaptation interventions in reducing local level vulnerability. RiPPLE. Water-Aid-Ethiopia, Addis Ababa
- NCDC (2020) Covid-19 Nigeria. Available at [ncdc.gov.ng](http://ncdc.gov.ng). Accessed 7 June 2020
- Nelson G, Bogard J, Lividini K, Arsenault J, Riley M, Sulser TB, Mason-D'Croz D, Power B, Gustafson D, Herrero M, Wiebe K, Cooper K, Remans R, Rosegrant M (2018) Income growth and climate change effects on global nutrition security to mid-century. *Nat Sustain* 1(12):773–778
- Nkurunziza L, Chirinda N, Lana M, Sommer R, Karanja S, Rao I, Romero Sanchez MA, Quintero M, Kuyah S, Lewu F, Joel A, Nyamadzawo G, Smucker A (2019) The potential benefits and trade-offs of using sub-surface water retention technology on coarse-textured soils: impacts of water and nutrient saving on maize production and soil carbon sequestration. *Front Sustain Food Syst* 3. <https://doi.org/10.3389/fsufs.2019.00071>
- Nwosu LE (2012, March) Climate change and food security: implication for effective agricultural extension services in Nigeria. In: *Proceedings of the 17th annual national conference of agricultural extension of Nigeria (AESON)*
- Obioha EE (2009) Climate variability, environmental change and food security nexus in Nigeria. *J Hum Ecol* 26(2):107–121
- Oliva R, Ji C, Atienza-Grande G, Huguet-Tapia JC, Perez-Quintero A, Li T, Eom J-S, Li C, Nguyen H, Liu B, Auguy F, Sciallano C, Luu VT, Dossa GS, Cunnac S, Schmidt SM, Slamet-Loedin IH, Vera Cruz C, Szurek B, Frommer WB, White FF, Yang B (2019) Broad-spectrum resistance to bacterial blight in rice using genome editing. *Nat Biotechnol* 37(11):1344–1350

- Report of WHO-China Joint Mission on Corona Virus Disease 2019 (COVID-19). 16–24 February 2020. Accessed 3 May 2020
- Sanders JM, Monogue ML, Jodlowski TZ, Cutrell JB (2020) Pharmacologic treatment for Corona virus diseases 2019. A Review. PMID: 32282022. <https://doi.org/10.1001/jama.2020.6019>
- Solly M (2019) One climate crisis disaster occurs every week, UN official warns. *Smithsonian Magazine*, 8 July 2019. <https://www.smithsonianmag.com/smart-news/un-expert-warns-one-climate-crisis-disaster-occurs-every-week-180972573>
- Tamirisa N (2008, March) Climate change and the economy. Finance & Development. <http://www.imf.org/external/pubs/ft/fandd/2008/03/pdf/tamirisa.pdf>. Accessed 23 Apr 2020
- United Nations Department of Economic and Social Affairs (2015) Sustainable development goals. Available at <http://www.un.org/sustainabledevelopmentmaterials>. Accessed 21 May 2020
- United States Global Change Research Program (USGCRP) (2009) Global climate change impacts in the United States. In: Karl TR, Melillo JM, Peterson TC (eds) *United States global change research program*. Cambridge University Press, New York
- USAID (2010) Adapting to climate variability and change a guidance manual for development planning. [http://pdf.usaid.gov/pdf\\_docs/PNADJ990.pdf](http://pdf.usaid.gov/pdf_docs/PNADJ990.pdf). Accessed 9 Apr 2020
- Velmurugan, G., Ramprasath, T., Gilles, M., Swaminathan, K. And Ramasamy, S. (2017). Gut microbiota, endocrine-disrupting chemicals, and the diabetes epidemic. *Trends Endocrinol Metabol*, 28(8): 612–625. <https://doi.org/10.1016/j.tem.2017.05.001>
- World Health Organization (2020) WHO Director-General’s opening remarks at the media Briefing on COVID-19 (Press release) 11 March 2020. “Advice for Public”
- Zenebe G, Stage J, Alemu M, Atlaw (2011) Climate change and the Ethiopian economy. A computable general equilibrium analysis: environment for development discussion paper series October 2011, EfD DP 11-09. <http://www.rff.org/RFF/Documents/EfD-DP-11-09.pdf> <http://www.vanguard.com/2020/04/covid-19-maintaining-food-security-in-crisis-situations>. Accessed 9 Aug 2019

**Open Access** This chapter is licensed under the terms of the Creative Commons Attribution 4.0 International License (<http://creativecommons.org/licenses/by/4.0/>), which permits use, sharing, adaptation, distribution and reproduction in any medium or format, as long as you give appropriate credit to the original author(s) and the source, provide a link to the Creative Commons license and indicate if changes were made.

The images or other third party material in this chapter are included in the chapter’s Creative Commons license, unless indicated otherwise in a credit line to the material. If material is not included in the chapter’s Creative Commons license and your intended use is not permitted by statutory regulation or exceeds the permitted use, you will need to obtain permission directly from the copyright holder.





# Role of Small Grains in Adapting to Climate Change: Zvishavane District, Zimbabwe **31**

Tendai Nciizah, Elinah Nciizah, Caroline Mubekaphi, and Adornis D. Nciizah

## Contents

Introduction .....	582
Smallholder Farming in Zimbabwe .....	584
Farmers' Perceptions on Climate Change in Zvishavane .....	586
Smallholder Solutions for Climate Change .....	588
Characteristics and Impact of Small Grain Production on Climate Change Adaptation in Zvishavane District .....	589
Perceived Barriers to Small Grain Production in Zvishavane .....	591
Lack of Inputs .....	591
Labor Intensiveness .....	592
The Challenge of Quela Birds .....	592
Low Yields .....	593
Lack of Knowledge .....	593
Lack of Markets .....	593

This chapter was previously published non-open access with exclusive rights reserved by the Publisher. It has been changed retrospectively to open access under a CC BY 4.0 license and the copyright holder is "The Author(s)". For further details, please see the license information at the end of the chapter.

T. Nciizah  
Department of Sociology, Rhodes University, Makhanda, South Africa

E. Nciizah  
Department of Development Studies, Zvishavane Campus, Midlands State University,  
Zvishavane, Zimbabwe  
e-mail: [nciizah@staff.msu.ac.zw](mailto:nciizah@staff.msu.ac.zw)

C. Mubekaphi  
School of Agricultural, Earth and Environmental Sciences, University of KwaZulu-Natal,  
Scottsville, South Africa

A. D. Nciizah (✉)  
Soil Science, Agricultural Research Council – Institute for Soil, Climate and Water,  
Pretoria, South Africa  
e-mail: [nciizaha@arc.agric.za](mailto:nciizaha@arc.agric.za)

Low Extension Services and Government Support .....	594
Food Preferences .....	594
Interventions to Overcome the Barriers to Small Grains Adoption .....	595
Conclusions .....	596
References .....	596

## Abstract

Climate change has become one of the most profound threats to smallholder agriculture in semi-arid and arid areas. Farmers in this sector are especially vulnerable to climate change due to reliance on rain-fed agriculture, limited access to capital and technology among other challenges. While several potential adaptation options exist, many barriers hinder effective adoption of these practices, hence production in marginal areas remains very low. This chapter discusses crop adaptation through the adoption of small grains in Zvishavane rural, a semi-arid area in Zimbabwe. Small grains are conducive in hot areas; their drought-tolerant nature enables them to thrive in marginal areas making them an appropriate strategy in responding to climate change. However, several production and policy challenges associated with small grain production hinder their adoption by farmers. In view of this, this chapter discusses the potential of small grains as an adaptation strategy to climate change in Zvishavane District, Zimbabwe, and addresses potential challenges and opportunities for increased adoption and future research. The review showed that farmers in Zvishavane have perceived climate change due to noticeable changes in rainfall and temperature patterns in the past years. Despite small grain production being the best strategy due to drought and high temperature tolerance, an insignificant number of Zvishavane farmers is involved in small grain production. This is due to numerous barriers such as high labor demand associated with small grain production, the challenge posed by the quelea birds, food preferences, low markets, and low extension services and government support. It is therefore necessary to encourage adoption of small grains by developing improved varieties, adoption of climate smart agricultural practices, improved technical support, and access to markets among other interventions.

## Keywords

Adaptation · Climate change · Mitigation semi-arid areas · Small grain production · Smallholder farmers · Vulnerability

## Introduction

Climate change has become one of the major threats to rain-fed agriculture resulting in major drawbacks in agricultural production and food security. IPCC (2007) notes that climate change has significantly modified rainfall and temperature patterns in many parts of the world. There is strong evidence of erratic rainfall and a noticeable shortening of the agricultural seasons worsened by higher ambient temperatures resulting in perennial crop failure and frequent droughts across the world (Jerie and

Ndabaningi 2011). The adverse effects of climate change are more pronounced within the smallholder agricultural sector in Africa, including Zimbabwe, compared to the more technologically advanced and high resource input commercial sector. Generally, smallholder agriculture is practiced by families or households using only, or mostly, family labor and deriving from that work a large but variable share of their income, in kind or in cash (HLPE 2013). It therefore follows that the livelihoods of smallholder farmers largely depend on agriculture and are particularly vulnerable to several hazards. Consequently, if changing climatic conditions continue unabated, traditional rain-fed agricultural systems will become increasingly unsustainable with severe food security implications.

Temperature in the sub-Saharan Africa region is predicted to increase by between 1 °C and 2.5 °C by 2030, which will ultimately result in yield losses of up to 20% by the 2050s depending on region (IPCC 2007). Consistent with regional data, Zimbabwe's annual mean surface temperature has warmed by about 0.4 °C from 1900 to 2000 with the period from 1980 to date being the warmest on record. Moreover, the timing and amount of rainfall received are becoming increasingly uncertain, with current data showing that during the last 30 years there has been frequent droughts and rainfall has significantly decreased with shorter seasons (GoZ 2014). Consequently, the Food and Agriculture Organization (FAO 2007) observed that the crop failures have been a result of early termination of the rains in most seasons or low rainfalls in Zimbabwe, especially in semi-arid areas. Gukurume (2013) perceived that climate change in countries like Zimbabwe has presented insurmountable challenges to the agricultural sector as well as agricultural sustainability. Droughts, floods, increased temperature, increased rainfall variability, and declining precipitation negatively affected agriculture in Zimbabwe, with other districts recording almost nothing in terms of output (Zimbabwe Agricultural Sector survey 2019). The 2018/19 cropping season was marked by a late onset of rains, which resulted in abnormally dry conditions, affecting agricultural activities such as land preparation and planting (IPC Zimbabwe 2019).

The effects of climate change in Zimbabwe are exacerbated by the concentration of most smallholder farmers in marginal soils in semi-arid and arid areas located in the natural region IV and V, which makes them more vulnerable to climate change due to their low adaptive capacity. High temperature and erratic rainfall have resulted in constant low yields of the preferred maize staple in the country. Maize is not a drought-tolerant crop; hence, it is highly sensitive to harsh environmental conditions, which negatively affect the yield (Muzerengi and Tirivangasi 2019). There is therefore a need to implement adaptation and mitigation strategies that will ensure resilience to climate change. Adaptation has the potential to reduce adverse impacts of climate change and to enhance beneficial impacts and hence reduce vulnerability both in the short and long term (IPCC 2001). There are several adaptation interventions that have been suggested for smallholder farmers including but not limited to crop relocation, adjustment of planting dates, and crop variety; improved land management, e.g., erosion control and soil protection incorporating agroforestry (IPCC 2007). However, due to the vulnerability of maize to drought, there is the need to move away from the production of maize and look for alternative crops that

thrive under changing climatic conditions. Sharma et al. (2002) highlighted that there is an urgent need to focus on improving crops relevant to the smallholder farmers and poor consumers in the semi-arid areas. This chapter focuses on the adoption of small grain crops, which have been shown to thrive under harsh conditions, as one of the most viable strategies that must be consistently implemented in such semi-arid and arid areas as Zvishavane District in Zimbabwe, which are facing significant production challenges due to climate change. Zvishavane District has experienced recurrent droughts, inconsistency rainfall, and is consequently one of the districts that constantly faces food insecurity in the country. According to Mawere et al. (2013), for the past two decades, Zvishavane, among others in Zimbabwe and beyond, has witnessed pronounced increases in temperature, recurrent droughts, and unpredictable rainfall patterns, yet people mainly depend on rain-fed agriculture and natural resources for their livelihoods. This chapter discusses the potential of small grains as an adaptation strategy to climate change in Zvishavane District, Zimbabwe, and addresses potential challenges and opportunities for increased adoption and future research. The chapter will answer the following questions:

- (i) What are the Zvishavane farmers' perceptions on climate change?
- (ii) To what extent are farmers in Zvishavane adopting small grains?
- (iii) What are potential barriers/challenges and opportunities for increased adoption of small grain crops in Zvishavane District?

---

## Smallholder Farming in Zimbabwe

The smallholder sector is known for its small farms, mostly less than 2 hectares that are labor-intensive, uses traditional production techniques, and often lack institutional capacity and support (Louw 2013). The definition of smallholder farmer depends on the country; for instance, in Zimbabwe, smallholder farmers are typically farmers who are food insecure, predominantly in low rainfall areas who depend on rain-fed agriculture. Their reliance on rainfall for agricultural production exposes them to the risks posed by climate change. Smallholder farmers face challenges such as lack of infrastructure, reliance on rain-fed systems, highly degraded soils, a variety of chronic crop-affecting diseases, tough economic conditions due to poorly functioning markets, and limited access to credit, knowledge, and lack of farming skills (Mutekwa 2009). Lack of assets, information, and access to services deters smallholder farmers' involvement in possibly profitable markets. Moreover, most smallholder farmers are confronted with labor limitations as a result of HIV/AIDS, chronic illness, poverty, and illiteracy. Furthermore, smallholder farmers lack adequate knowledge, which leads to poor selection of cultivars, fertilizer application, and delayed planting of crops. As a result, the crop yields are negatively impacted. Worse still they are far from road networks to transport inputs, produce, and also access information and have a tendency to use inefficient modes of transport such as animals. In Zimbabwe there is nonexistence of investment in infrastructure, for instance, roads, storage, and market

facilities and this handicap the potential role of smallholder farmers. This problem is not only common in Zimbabwe but the rest of Africa as well as most African government policies are unsuitable and inconsistent, and do not provide an enabling environment for the development of the small grains sector.

Mutasa (2011) highlighted the reasons below as challenges or factors that farmers are faced with that also increase farmers' vulnerability to climate change.

- (a) Poor soil moisture holding capacity
- (b) Lack of necessary farming knowledge
- (c) Lack of draught power
- (d) Difficulties accessing the appropriate inputs on time
- (e) Inadequate farming space
- (f) Poor rains and/poor rainfall distribution
- (g) Communities' failure to fully recover from previous drought disasters
- (h) Poor fiscal policies resulting in hyperinflation and inaccessibility to cash especially after the dollarization of the economy
- (i) Poor governance evidenced by the suspension of humanitarian organizations' operations when they were greatly needed
- (j) Politicization of food assistance and input schemes (benefitting only supporters of a particular party)
- (k) Corruption associated with input facilities
- (l) Communities' focus on maize production at the expense of other traditional crops
- (m) Depletion of human resources and sources of income due to brain drain, HIV, and AIDS and other epidemics

All the above mentioned challenges affect their competitiveness and it leads to them having high transport costs to sell their products in the market and buy inputs. In addition, smallholder farmers face challenges in accessing markets due to inadequate infrastructure, low productivity levels, inconsistencies in supply, and low quality owing to poor post-harvest practices (FAO). Smallholder farmers do not make much income as they lack a reliable market and as a result sell their produce at their farm gates or local market where they sell below market value (Aaron 2012). They tend to be inconsistent in production due to lack of bargaining power and inability to reliably supply their products fresh to markets (Aaron 2012). Harvested crops are threatened by insects such as weevils, larvae, termites, and rodents such as rats; these insects may be present in the grains making it less marketable. Some of the pests are attributed to lack of storage facilities as some smallholder farmers store grain in their sleeping quarters whereas those who have structures tend to be in very poor conditions and hence cannot hinder pest attack.

Changing climatic conditions have become one of the major challenges affecting smallholder farmers in Zimbabwe and the rest of the world. In 2016 and 2017, Zimbabwe had a drought, which was aggravated by the impact of El Niño. Smallholder farmers tend to suffer from these disasters due to their low adaptive capacity, which increase their vulnerability, hence they have no means of recovering from the effect this has on their livelihoods. Most smallholder farmers have a tendency to



recover by selling their productive assets, such as their livestock or land. Moreover, these persistent droughts, which have taken place over the past few years due to changes in climate, continue to erode maize yields. For instance, maize yields have been reduced to less than  $1.5 \text{ ton ha}^{-1}$  against a potential yield of more than  $5 \text{ tons ha}^{-1}$  (de Jager et al. 2001).

Semi-arid and arid regions like Zvishavane district have some of the worst affected farmers in Zimbabwe. Zvishavane is a district in Zimbabwe bordered by Mberengwa, Chivi, and Shurugwi districts. The mean annual temperature is  $20 \text{ }^\circ\text{C}$  although high temperatures of up to  $30 \text{ }^\circ\text{C}$  have been recorded during the hot months from October to December (Nciizah 2014). The area receives an annual rainfall of about 450–600 mm placing it in region IV but during droughts there can be just 250 mm of rain (Oakland Institute Undated). According to the OCHA report (2012), region IV is subject to periodic seasonal droughts and severe dry spells during the rainy seasons, and crops can only be intensified by growing of drought-tolerant crops. Natural farming regions are a classification of the agricultural potential of the country, from natural region I ( $>1000 \text{ mm per annum}$ ), which represents high altitude wet areas to natural farming region V, which receives low and erratic rainfall averaging 550 mm per annum (Mugabe et al. 2007). The table below shows the agroecological regions in Zimbabwe and their characteristics.

Rainfall in Zvishavane has been erratic such that in some areas like Mazvihwa, rain-fed agriculture has become unreliable, worsened by droughts that have gripped the country (Nciizah 2014). Despite the hot climatic condition of the district, agriculture remains the main source of livelihoods (Mugiya and Hofisi 2017). Just like all areas in Zimbabwe, the main crop grown by smallholder farmers in Zvishavane is maize. Droughts and little rainfall in the district have led to low maize crop yields leading to food insecurity to be high in the area. According to ZimVac (2015), Zvishavane was one of the districts with the highest food insecurity levels with 42.2%. In 2016, the level went up with 50% households being food insecure, hence the need for adaptation and mitigation measures in smallholder farming areas (ZimVac 2016). Adaptation measures include adjustment of planting dates and crop variety, crop relocation among others. However, one of the most recommended approach is the growing of drought-tolerant crops such as small grains (Gukurume 2013; Muzerengi and Tirivangasi 2019; Musara et al. 2019). Adoption of small grains becomes a crucial necessity that must be embraced by households in the area. Small grains grown in the area are sorghum and millet, with finger millet being more common than pearl millet (Nciizah 2014).

---

## Farmers' Perceptions on Climate Change in Zvishavane

Smallholder farmers in Zvishavane perceive climate change using two variables, which are temperature and precipitation paying attention to events that have been occurring in the area for the past 10 to 20 years. Perceiving that climate is changing is crucial as it leads to adaptation. According to Jiri et al. (2015), perceptions help to shape smallholder farmers' coping and adaptation strategies. Adaptation is a

two-step process, which requires that farmers first notice that the climate has changed and then secondly, implement adaptation strategies. Farmers' ability to acknowledge the importance of adapting therefore largely depends on whether they have observed that there is climate change in the first place (Nciizah 2019). Most studies have shown that farmers who perceive that the climate is changing in line with the actual climate change records are most likely to adapt to climate change (Jiri et al. 2015). Simba et al. (2012) concurs that the most crucial element in spearheading adaptation options is for farmers to perceive climate change. Such farmers who perceive that the climate has changed, for instance, will be able to realize a sharp decrease in maize yields. Numerous studies have been done on farmers' awareness on climate change (Gbetibouo 2009). A study by Okonya et al. (2013) in Uganda showed that 99% of all households interviewed had observed a change in the climate in the last 10 years.

The greatest concern for farmers in Zvishavane is the drastic changes in rainfall patterns and temperature. This is confirmed by the records from meteorological centers. A study by Jiri et al. (2015) also confirmed the decline in rainfall and an increase in temperatures over the years. Similarly, Mutekwa (2009) showed that farmers in Zvishavane were mainly concerned with precipitation and temperature-related weather events, as the ones that are a real concern in relation to their agricultural activities. There are now more experiences in dry spells and cold spells. Murowa ward in Zvishavane is already a drought prone area and farmers indicated that dry spells have become more frequent and devastating in recent years (Mutekwa 2009). Farmers in the area now experience extremely high temperatures and very low rainfall. Maddison (2006) also reported a similar trend of increasing temperatures in his study in 11 African countries. Another concern for smallholder farmers in Zvishavane is the changing onset of the rainfall season, which was confirmed by a study done by Mawere et al. (2013) in Zvishavane and Chivi. The study revealed that the climatic conditions that have prevailed for the past 5 years or so in agro ecological regions IV and V were very hot with dry conditions. There was rainfall below average (300 mm per annum) with poor distribution giving high chances of dry spells. In the past, the area used to receive three groups of rainfall, which are Bumharitsva (August), Hukurahundi (September), and Munakamwe (November) per year. Now they only receive one rainy season (munakamwe), which is also not predictable (Mawere et al. 2013). In addition, the farmers used to receive the last rains in March but this is no longer the case. The rains are no longer predictable as they can come very late and end early, something that has proved to be challenging to the farmers.

In the same study by Mawere et al. (2013), it was discovered that 96% of the respondents acknowledged their awareness of the changes in their local weather pattern and climate change. Many smallholder farmers in the study perceived the following as indicators: less and less rainfall leading to droughts, dwindling farming seasons, unpredictable weather patterns, high temperatures, decrease in livestock and crop production, low fruit production of wild fruit trees, and extinction of some area-specific species. Many smallholder farmers in Zvishavane have noted that although the coldest month of the year in Zimbabwe is June, it has been becoming less cold and the hottest month and October has become hotter than the previous

years. It has also become apparent for most farmers that precipitation has been declining for years with more frequent drought occurrences. Drought occurrences have largely contributed to low yields and drastic effects on livestock production (Jiri et al. 2015). Farmers in Zvishavane have perceived inconsistent rainfall patterns and arid conditions in the area, which have led to the perennial flop of maize production (The Chronicle 2020). A survey done by International Crops Research Institute for the Semi-Arid Tropics (ICRISAT) noted that most farmers in Mberengwa and Zvishavane have been realizing very low yields from maize and other crops because of the effects of climate change (The Chronicle 2020).

Wetlands in Zvishavane have also declined over the years. Farmers in Zvishavane pointed out that their cattle used to drink water at wells and wetlands around the area but the wetlands are no longer there and they have to fetch water from distant places (Mawere et al. 2013). They also add that mountains in the area used to have wind storms signifying coming of heavy rains. This however no longer happens. Storms used to signify rainfall as well as animals such as ducks, baboons, rain bird-blue bird. Such animals are no longer existent as they have moved to other areas in search of food (Mawere et al. 2013).

---

## Smallholder Solutions for Climate Change

Climate change has rendered Zimbabwe's region IV a non-maize producing zone due to climate shocks, a situation that promotes food insecurity (Mugiya and Hofisi 2017). This has left the majority of people in semi-arid areas food insecure, which calls for the need for adaptation. Given the reliance of most people in Zimbabwe on rain-fed agriculture, it becomes pertinent to identify solutions that can be implemented in order to deal with the insurmountable challenges posed by climate change. There are a couple of solutions that have been identified in some studies inclusive of conservation agriculture, irrigation, and gardening. A study by Mutasa (2011) showed that farmers in Buhera and Chikomba districts have incorporated certain strategies to address droughts that are prevalent in the area. The strategies are inclusive of early cropping, staggered cropping, dry planting, and planting crops with a short maturity life. This study recommends the production of small grains in semi-arid areas like Zvishavane. Small grain production will likely curtail the numerous challenges faced by farmers in Zvishavane given the advantages posed by small grains. Small grains have always been there and are not new as they were there before the introduction of maize; they are an indigenous African crop with more nutritional benefits than maize.

Several studies have looked at how small grains can lead to food security especially in semi-arid areas (Leuschner and Manthe 1996; FAO 2006; Mukarumbwa and Mushunje 2010). They highlight the numerous advantages associated with small grain production. Among such advantages are their nutritious value, drought resistance, and how they can be stored for longer periods as compared to maize. Leuschner and Manthe (1996) pointed out that sorghum and millet are some of the most important cereal crops for communal farmers in Natural Regions

1 V and V of Zimbabwe. Their study showed that in regions with low and erratic rainfall like Zimbabwe's Natural Regions 1 V and V, small grains have the potential of stabilizing household food security. In a study by Taylor (2003), sorghum and millet are vitally important cereals for the maintenance of food security in Africa. FAO (2006) also supports that small grains are the answer to chronic food shortages to rural communities who reside in semi-arid regions, especially of the sub Saharan region.

---

## **Characteristics and Impact of Small Grain Production on Climate Change Adaptation in Zvishavane District**

As alluded to earlier, more than 475 million smallholder farmers across the globe cultivate less than 2 ha of land each (Lowder et al. 2016) on poor and marginal land with lack of access to technical or financial support that could help them invest in more climate-resilient agriculture (Morton 2007). These challenges are exacerbated by the effects of climate change, hence the need for appropriate adaptive and mitigation measure. Due to these challenges, smallholder farmers in semi-arid to arid areas continue to achieve very low yields. Growing small grains becomes an adaptation measure that smallholder farmers in areas prone to water and heat stress need to implement instead of maize, which is highly susceptible to water stress. Although maize is the preferred grain crop in Zvishavane and the rest of Zimbabwe, it is frequently written-off due to frequent droughts (Nciizah 2014) resulting in maize yields below 1 ton/ha. Consequently, small grain crops like millet and sorghum, which can better withstand drought conditions and offer more stable yields in the long term, are a better choice (Nciizah 2014; ICRISAT 2015). Small grains, particularly sorghum, adapt well to harsh climates and thus can grow in dry conditions due to their ability to tolerate heat, salt, and water stress, which makes them an ideal crop for semi-arid and arid areas (ICRISAT 2015).

There has been a conscious drive by the Government of Zimbabwe (GoZ) to urge farmers in arid and semi-arid to opt for small grain as a coping mechanism to climate change as evidenced by the increase in programs promoting sorghum production (GoZ 2014). The government of Zimbabwe has been working with international organizations such as FAO and ICRISAT to assist farmers in the country's marginal areas to focus more on the production of small grains such as sorghum and millet in order to counter poor yield and hence hunger. In Zimbabwe, small grains (sorghum, pearl, and finger millet) rank second after maize and consequently play a vital role in ensuring food security and nutrition (UNDP 2018b).

Droughts and dry spells have made smallholder farmers in Zvishavane to be expected to rely on irrigation schemes if they want to produce good maize yields. Unfortunately most of these farmers do not have the financial capacity to purchase the required equipment and the much needed fertilizers (Nciizah 2014). It is therefore vital for these farmers to concentrate more on small grain production compared to maize. Most of the farmers in the area are still concentrating on maize production with only a few household producing small grains. They still follow the norm of the

country whereby maize is the mainstay crop even in drier areas where small grains can be produced economically and sustainably (Rukuni et al. 2006). However, this needs to change as maize production is no longer conducive for semi-arid areas that are constantly facing droughts and erratic rainfall. Recently, Zvishavane faced a drought in the 2019/2020 season leading to crop failure. In such circumstances, full adoption of small grain adoption becomes a necessity if the area is to avoid zero crop yields. This is mainly because small grains have characteristics and properties that allow them to thrive in areas like Zvishavane.

Sorghum and millet are important traditional cereal crops in Africa (Chisi Undated). Notably these cereals are indigenous to the African continent (Musara et al. 2019), making them well adapted to the African semi-arid areas (Taylor 2003). These small grains have become favored because of their good adaptation to hard environments and their good yield of production. The grains are drought resistant as compared to maize, making them to thrive in areas that are hot and have limited rainfall. Water requirements over the growing period average 400 mm for sorghum and 300–350 mm for millet as compared to 500 mm that is required for maize (Orr et al. 2016). Hence, they are genetically adapted to drylands that face little and irregular rainfall, drought, and high temperatures than other cereals like maize. This makes them to be able to give some yields in years of low rainfall, especially when grown in a multi-cropped system, whereas maize will be a complete failure (Muzerengi and Tirivangasi 2019).

Sorghum and millet also have deeper roots than maize and can withstand higher temperatures without damage to the crop (Orr et al. 2016). Bang and Sitango (2003) point out that small grains are generally the most drought-tolerant cereal grain crops as they require little input during growth. They bring more nutritional value to people's diet compared to cereals like maize. Dube (2008) posits that some of the advantages of small grains like sorghum and millet over maize include the following: a smaller amount of flour is needed to cook the main meal compared to maize, and a meal cooked from small grains satisfies hunger for a longer period and gives more energy (which is especially important for persons who do heavy manual labor like farmers).

Specifically, looking at finger millet, it can be observed that the crop has valuable properties that make it more beneficial to grow in the semi-arid of Zvishavane. The cereal is drought resistance in nature, has high nutritional content and has the ability to produce with few inputs. Finger millet is a nutritious crop providing proteins, carbohydrates, minerals, and amino acids, especially methionine, which is lacking in the diets of numerous poor people who live on starchy foods (Bhatt et al. 2003). This goes the same with sorghum, which remains important for sustainability of small-holder farmers' subsistence, social and economic livelihoods in semi-arid areas (Musara et al. 2019). Sorghum grain contains 11.3% protein, 3.3% fat, and 56–73% starch (National Research Council, 1996). It is relatively rich in iron, zinc, phosphorus, and B-complex vitamins. Tannins, found particularly in red-grained types, contain antioxidants that protect against cell damage, a major cause of diseases and aging (National Research Council, 1996). Thus, sorghum and millet have the capability of providing the nutritional value that can boost the immune

system of people particularly poor families. They both have more health nutrients compared to maize, wheat, and rice and they improve the physical health of the elderly, the sick, children, and pregnant and nursing women. Another advantage of sorghum and finger millet maize is that they have a long shelf storage life as they can be stored for about 5 years compared to maize, which is only stored for about 2 years. Hence, they become conducive in Zvishavane, a place that is facing consistency drought and erratic rainfalls.

Although small grains are mostly suitable for Zvishavane, research conducted in the area shows that most smallholder farmers are still reluctant to fully adopt the grains. Mawere et al. (2013) in a study in Zvishavane stated that in as much as farmers reported that small grain crops performed much better than maize, most farmers still preferred growing maize. Similarly, Nciizah (2014) observed that an insignificant number of farmers were cultivating small grains in the area. Mugiya and Hofisi (2017) reported that while small grain crops prove to be a viable option to boost production in the background of climate change vulnerability, people in Zvishavane were not adopting such varieties enthusiastically, as adopting such varieties threatened their food preference. Hence, in Zvishavane, a significant number of households still prefer maize over small grain production. There are a number of barriers that have affected small grain production in Zvishavane. This has made the area to be consistently food insecure as smallholder farmers still grapple with inadequate yields.

---

## Perceived Barriers to Small Grain Production in Zvishavane

Despite the advantages associated with small grains, small grain production remains low with only a few farmers producing these around Zimbabwe and specifically in Zvishavane. Studies done in Zimbabwe have shown that small grain production continue to decline (Gukurume 2013). The production of small grains has been very low in Zvishavane and the decline in small grain production is due to a number of barriers, which are central to this chapter. As indicated by smallholder farmers in Zvishavane the major barriers to small holder production are labor constraints associated with small grain production, the challenge of birds (quelea birds), lack of inputs, and challenges associated with storage among other aspects. Studies have shown that small grain production is a good adaptive strategy, but is difficult to implement given the problems associated with the production of the crops. All barriers central to small grain production in Zvishavane are discussed below:

---

### Lack of Inputs

UNDP (2018a) carried out a study on the barriers to small grain production. Their study showed that there are constraints in accessing inputs that limits the uptake of small grains. Overall, the results of the study showed that there is overreliance of farmers on untreated seed, evidencing inefficiency of the formal market. The study

confirmed that treated and packed seed is not readily available in local markets or alternatively, if available, farmers do not afford the improved seed. This is the same case as what is transpiring in Zvishavane. There is limited access to small grain seeds, which reduces its production. In most cases, farmers end up using untreated seed, which largely contributes to poor yields.

While improved varieties of seeds have been released by NGOs in Zvishavane District, the seeds of these small grains are not readily available from the various seed producers (Nciizah 2014). Whether farmers in Zvishavane want to produce small grains or not, their choices are affected by limited seeds. Christian Care, a non-governmental organization (NGO) operating in Zvishavane, has distributed seeds to farmers but with limited stock, which has resulted in few farmers accessing it. In addition, given the limited seed stock of small grains and the easier accessibility of maize seeds most farmers end up preferring maize. Mugiya and Hofisi (2017) cited that in Zvishavane there is too much politicization of programs geared to boost productivity among small-scale farmers. Farmers in the area revealed that farm inputs (inclusive of seeds), which are meant to benefit smallholder farmers, are usually diverted for political initiatives impacting negatively on small grain production. In most cases farmers in Zvishavane end up planting sorghum seeds that they saved from their yield (Mugiya and Hofisi 2017). Most of these seeds are of very low quality, which impacts heavily yield.

---

## Labor Intensiveness

The cultivation of small grains is extremely laborious, from land preparation, weeding, bird scaring to harvesting and grain processing. Most farmers in the area rely on manual production methods, which explains why labor intensiveness is a major concern. Nciizah (2014) noted that 95% of farmers in Zvishavane pointed to the labor intensiveness associated with small grain production as a very significant challenge. The study also showed how weeding is made more challenging by the similarities that exist between the weed "*Eleusine Indica*" and finger millet. The two are so similar that in most cases one might end up removing the crop and leaving the weed. There is also so much labor associated with harvesting the small grains given that the seeds are too small to handle and so much is done manually. Because the seeds are small it takes skill and much effort to mill finger millet (Nciizah 2014; UNDP 2018a). Farmers also mentioned the labor demands associated with processing of small grains as one of the limiting factors. Farmers in the study mentioned how processing of small grains is laborious as it involves threshing and winnowing, which is also done manually.

---

## The Challenge of Quela Birds

Even though small grains are generally tolerant to diseases there is a huge challenge of damage by quela birds. Like in most studies (Nciizah 2014; UNDP 2018a), birds and animals are the major challenges in small grain production. According to

Nciizah (2019), the birds are attracted by the grain of the crops as the grains are exposed unlike those of maize, which is covered by leaves. Chasing birds is highly regarded as a strenuous activity that most farmers cannot embark on. Farmers in Zvishavane prefer producing maize as maize is prone to attacks by baboons and wild pigs, which are easier to scare away than birds which attack the crop in large numbers and are difficult to chase away (Nciizah 2014).

---

## Low Yields

In Zimbabwe, production of maize continues to dominate in the country's semi-arid regions as compared to small grains (Sukume et al. 2000). The lower productivity associated with small grains makes them very unattractive to communal farmers in semi-arid areas. Small grains also require large farm size, which is out of the reach for most farmers in Zvishavane. Given the limited farm size in most places in Zvishavane, most farmers then prefer producing maize. A few of those who produce small grains have large land size and can also provide labor required to produce these. Some studies have also discovered that small grains do not yield much crop residue as compared to maize, resulting in most farmers preferring maize production. According to Mapfumo et al. (2005), maize production provides crop residue for livestock, which the livestock largely depend on for survival during winter.

---

## Lack of Knowledge

Despite the evidently dismal performance of maize in the area as a result of the effects of climate change, most farmers have for years been disregarding and fiercely resisting advice from agricultural experts to plant small grains (The Chronicle 2020). Research has shown that people tend to be largely ill-informed about small grain production. Many farmers in Zvishavane ignored the calls to adopt small grain production and in many instances continued to produce maize despite the realization that they are likely to get very low yields due to drought (Nciizah 2014). This is largely attributed to taste preferences and the low yields associated with small grains. Due to unawareness and lack of prioritization of small grains, most farmers end up cultivating small grains in their worst part of arable land, which heavily impacts production yields.

---

## Lack of Markets

It has been found out that when it comes to selling small grains, it has a very low market as people prefer other agricultural produce like maize. This is also confirmed by a study done by FAO (1996), which explains that as incomes rise, consumers tend to purchase wheat, rice, and, in some cases, maize, rather than traditional coarse grains. This has resulted in farmers viewing small grains as having lower earnings than other crops. Nciizah (2014) showed that one major disadvantage of small grains



cited by Zvishavane farmers is the limited marketing opportunities. In the study farmers complained about the absence of a ready market for small grains. Farmers in Zvishavane do not rely on the Zimbabwe Grain Marketing Board (GMB) to buy small grains. According to Mugiya and Hofisi (2017), farmers complained that the GMB normally delays to pay farmers, a situation which further complicates their adaptation, as their purchasing power remains poor.

---

## Low Extension Services and Government Support

Mukarumbwa and Mushunje (2010), show that small grain production has been negatively affected by inadequate government support. Research has shown that sorghum and millet are the most drought-tolerant cereal grain crops suitable in semi-arid regions (Taylor et al. 2006). The agricultural extension services department (AGRITEX) and the Department of Meteorological Services have extensively been incapacitated as a result of the country's economic and political challenges over the past decades that resulted in brain drain of skilled staff (Mutasa 2011). This has had a negative impact on farmers' production capacity and delivery of information about appropriate seeds and production technology. Mukarumbwa and Mushunje (2010) in their study indicated that inadequate government support to promote small grain production has led to low productivity of these small grains. Mugiya and Hofisi (2017) indicated that NGOs in Zvishavane are allegedly accused of imposing programs on small-scale farmers. The study also revealed that this also applies to government officials like extension officers. Extension officers believe that small-scale farmers are rigid and thus end up forcing farmers to adopt small grains. The farmers end up facing a challenge as their perceptions end up being ignored.

---

## Food Preferences

A significant production constraint toward small grain production is food preferences. Most Zvishavane farmers significantly prefer maize due to taste preferences as compared to small grains. Mugiya and Hofisi (2017) reported that while small grain crops prove to be a viable option to boost production in Zvishavane in light of climate change, most farmers are not adopting small grains enthusiastically as it threatens their food preference. Such preferences affect the overall production of small grains. There remains a strong inclination to maize production as compared to small grain production. Maize is easily processed compared to small grains, which makes maize widely accepted. Jones (2011) pointed out food taste, media, and education as influential to people's food preference. Mugiya and Hofisi (2017) also indicated that children prefer maize to millet and sorghum. Food security in Zvishavane has been hindered due to farmers' rejection to produce small grains.

## Interventions to Overcome the Barriers to Small Grains Adoption

Despite the huge potential of small grain crops to provide a viable adaptation mechanism to climate change, adoption among smallholder farmers remains disappointingly low due to the barriers addressed above. There is need for practical solutions from all stakeholders that will make the crop attractive for smallholder farmers in drought prone regions such as Zvishavane District. A comprehensive review by UNDP (2018b) on emerging solutions to small grains value chains in Zimbabwe identified the following interventions;

- (i) Availing improved varieties
- (ii) Improved processing methods and equipment
- (iii) Improved post-harvest management
- (iv) Improved access to markets for both inputs and outputs

These interventions are likely to make small grain crops more attractive for smallholder farmers. For instance, Musara and Musemwa (2020) showed that the allocation of more land toward improved sorghum varieties by smallholder farmers resulted in improved food diversity and food access. Moreover, improved varieties are likely to be more resilient to elevated temperature and low rainfall conditions due to climate change. However, it is necessary for stakeholders to increase funding for the development of improved small grains varieties, which currently lags behind of maize. Nevertheless, it is important that breeders, seed companies, seeds suppliers, processors, and retailers work closely with smallholder farmers to effectively understand and incorporate farmers' preferences as the end users.

It is also important to note that while small grains like sorghum perform comparatively better than maize under harsh conditions, unfavorable soil conditions, extremes in weather, pests, and poor management practices negatively affect yield. Consequently, it is important to complement improved varieties with sustainable cropping practices. One of the most widely recommended approaches is climate smart agriculture (CSA), which entails agricultural practices that concurrently increase productivity, strengthens resilience to climate change (adaptation), reduces/removes GHGs (mitigation), and contributes to achieving food security and development objectives (FAO 2010). Examples of such practices include conservation agriculture, legume intercropping, agroforestry, organic agriculture, and improved pest, water, and nutrient management. These practices significantly improve soil health, which ultimately improves crop productivity. Improved cropping practices have a potential to improve yields, which may in turn increase adoption of small grains. An increase in the adoption of the crop may in turn make seed production more attractive for established seed companies, who currently do not see the benefit of producing small grain seed due to low sales. However, for farmers to adopt these sustainable agricultural practices, there is a need to strengthen technical support services. Poor technology as well is generally one of the most prevalent challenges to agricultural production and uptake of new technology in smallholder farming areas.

## Conclusions

The Chapter examined the role played by small grains in adapting to climate change in Zvishavane. Farmers in Zvishavane have perceived climate change as they have noticed changes in rainfall and temperature patterns in the past years. Such perceptions have been helpful in assisting many farmers to realize the need to adapt to climate change. The most appropriate way to adapt to climate change in the area as shown in this chapter is small grain production. Small grain production is the best strategy given that small grains are drought resistant and can withstand the hot temperatures in Zvishavane. However, despite this realization, an insignificant number of Zvishavane farmers are involved in small grain production. This is due to numerous barriers that have affected the smooth implementation of small grains. Such barriers are inclusive of the labor associated with small grain production, the challenge posed by the quelea birds, food preferences, low markets, and low extension services and government support. If nothing is done to mitigate these barriers, Zvishavane will continue to be a food insecure area. In this regard, the chapter highlighted possible interventions that can assist in helping farmers adopt small grains, which include the development of improved varieties, adoption of CSA practices, improved technical support, and access to markets. The labor intensiveness associated with small grain production requires technology and machinery that help in reducing manual labor. There is also need for policies promoting small grain production and processing to add value to small grains.

---

## References

- Aaron J (2012) A framework for the development of smallholder farmers through cooperative development. Directorate Co-operative and Enterprise Development Department: Agriculture, Forestry and Fisheries Republic Of South Africa. Available at: [https://www.nda.agric.za/doiDev/sideMenu/cooperativeandenterprisedevelopment/docs/FRAMEWORK-%20OF%20SMALL%20FARMERS%20\(2\).pdf](https://www.nda.agric.za/doiDev/sideMenu/cooperativeandenterprisedevelopment/docs/FRAMEWORK-%20OF%20SMALL%20FARMERS%20(2).pdf)
- Bang K, Sitango K (2003) Indigenous drought coping strategies and risk management in Papua New Guinea, Cgprt Monograph 43
- Bhatt A, Singh V, Shrotria PK, Baskheti DC (2003) Coarse grains of Uttaranchal: ensuring sustainable food and nutritional security. Indian Farmer's Digest, Luchnow
- Chisi (Undated) Sorghum and Millet Breeding In Southern Africa in Practice, Golden Valley Research Station, [www.afripro.org.uk](http://www.afripro.org.uk)
- Dube C (2008) The impact of Zimbabwe's Drought Policy On Sontala Rural Community In Matabeleland South Province, Msc Thesis, Department Of Geology, Geography And Environmental Studies, Stellenbosch University
- FAO (1996) Rome declaration on world food security and world food summit plan of action. World food summit 13–17 November 1996, Rome
- FAO (2006) Fertilizer use by crop in Zimbabwe. Rome, Italy
- FAO (2007) Climate change and food security, in United Nations Joint Press Kit for Bali Climate Change Conference, December 3–14, 2007, Bali
- FAO (2010) Climate-smart agriculture policies, Practices and Financing for Food Security, Adaptation and Mitigation. Rome, Italy. <http://www.fao.org/docrep/013/i1881e/i1881e00.pdf>
- Gbetibouo GA (2009) Understanding farmers' perceptions and adaptations to climate change and variability: the case of the Limpopo Basin, South Africa IFPRI discussion paper. International Food Policy Research Institute, Washington, DC, forthcoming

- Government of Zimbabwe (GoZ) (2014) Zimbabwe's climate change response strategy. Government of Zimbabwe, Ministry of Environment, Water and Climate, Harare
- Gukurume S (2013) Climate change, variability and sustainable agriculture in Zimbabwe's rural communities. *Rus J Agric Soc Econ Sci* 14(2):89–100
- HLPE (2013) Investing in smallholder agriculture for food security: a report by the high level panel of experts on food security and nutrition. HPLE report no. 6. Food and Agriculture Organization, Rome
- Integrated Phase Classification Acute Food Insecurity Analysis Zimbabwe (IPC) (2019) Integrated food security phase classification: evidence and standards for better food security and nutrition decisions. FAO, Rome
- Intergovernmental Panel on Climate Change (IPCC) (2001) Climate change 2001: impacts, adaptation vulnerability. Contribution of working group II to the third assessment report of the intergovernmental panel on climate change. Unep/Wmo, Geneva
- Intergovernmental Panel on Climate Change (IPCC) (2007) Climate change: synthesis report. Contributions of working groups I, II and III to the fourth assessment report of the intergovernmental panel on climate change. IPCC, Geneva
- International Crops Research Institute for the Semi-Arid Tropics (ICRISAT) (2015) "Is conservation agriculture an option for vulnerable households?" Briefing note 4, September. ICRISAT. Bulawayo, Zimbabwe
- de Jager A, Onduru D, Van Wijk MS, Vllaming J, Gachini GN (2001) Assessing sustainability of low-external input farm management systems with the nutrient monitoring approach: A case study in Kenya. *Agric Syst* 69:99–118
- Jerie S, Ndabaningi T (2011) The impact of rainfall variability on rainfed tobacco in Manicaland province of Zimbabwe. *J Sustain Dev Afr* 13(1):241–250
- Jiri O, Mafongoya P, Chivenge P (2015) Smallholder farmer perceptions on climate change and variability: a predisposition for their subsequent adaptation strategies. *J Earth Sci Clim Change* 6:277. <https://doi.org/10.4172/2157-7617.1000277>
- Jones S (2011). How does a food systems approach elucidate the food insecurity of Inuit in Canada? Global Environmental Change and Food Systems, GECAFS Working Paper7. University of Oxford
- Leuschner K Manthe CS (1996) Drought tolerant crops for Southern Africa. In: Proceedings of the SADC/ICRISAT regional sorghum and pearl millet workshop, 25–29 July 1994. Gaborone, Botswana
- Louw A (2013) Sustainable policy support for smallholder agriculture in South Africa: key issues and options for consideration. In: Greenburg S (ed) Smallholder and agro-food value chains in South Africa. PLAAS, Bellville
- Lowder SK, Scoet J, Raney T (2016) The number, size, and distribution of farms, smallholder farms, and family farms worldwide. *World Dev* 87:16–29
- Maddison D (2006) The perception of and adaptation to climate change in Africa. CEEPA discussion paper no. 10. Centre for Environmental Economics and Policy in Africa, University of Pretoria
- Mapfumo P, Mtambanengwe F, Giller KE, Mpeperek S (2005) Tapping indigenous herbaceous legumes for soil fertility management by resource-poor farmers in Zimbabwe. *J Agric Ecosyst Environ* 109:221–233. [Online]. Available from: <http://www.sciencedirect.com>
- Mawere M Madziwa BF Mabeza CM (2013) Climate change and adaptation in third world Africa: a quest for increased food security in semi-arid Zimbabwe. *Int J Human Soc Stud*. Issn 2321–9203
- Morton J (2007) The impact of climate change on smallholder and subsistence agriculture. *PNAS* 104:19680–19685
- Mugabe FT Hodnett M Senzanje A (2007) Comparative hydrological behaviour of two small catchments in semi-arid Zimbabwe. *J Arid Environ*. <https://doi.org/10.1016/J.Jaridenv.2006.11.016>
- Mugiya D, Hofisi C (2017) Climate change adaptation challenges confronting small scale farmers. *Environ Econ* 8(1):57–65. [https://doi.org/10.21511/ee.08\(1\).2017.06](https://doi.org/10.21511/ee.08(1).2017.06)
- Mukarumbwa P, Mushunje A (2010) Potential of sorghum and finger millet to enhance household food security in Zimbabwe's semi-arid regions: a review, contributed paper presented at the joint

- 3rd African Association of Agricultural Economists (AAAE) and 48th Agricultural Economists Association of South Africa (AEASA) Conference, Cape Town, South Africa, September 19–23, 2010
- Musara JP, Musemwa L, Mutenje M, Mushunje A, Pfukwa C (2019) Determinants of sorghum adoption and land allocation intensity in the smallholder sector of semi-arid Zimbabwe. *Span J Agric Res* 17(1):E0105. <https://doi.org/10.5424/Sjar/2019171-13115>
- Musara JP, Musemwa L (2020) Impacts of improved sorghum varieties intensification on household welfare in the mid-Zambezi Valley of Zimbabwe. *Agrekon* 59(2):254–267
- Mutasa M (2011) Climate change vulnerability and adaptation in failing states: Zimbabwe's Drought struggle: Paper prepared for the Initiative on Climate Adaptation Research and Understanding through the Social Sciences (ICARUS-2) meeting at the University of Michigan (5–8 May 2011) themed, "Vulnerability and Adaptation: Marginal Peoples and Environments." Although there are several climate change-induced impacts, this paper focuses on drought, which poses a huge challenge in rural rain-fed agro-economies
- Mutekwa VT (2009) Climate change impacts and adaptation in the agricultural sector: the case of smallholder farmers in Zimbabwe. *J Sustain Dev Afr* 11(2):237–256
- Muzerengi T, Tirivangasi HM (2019) Small grain production as an adaptive strategy to climate change in Mangwe District, Matabeleland South in Zimbabwe. *Jamba J Disaster Risk Stud* 11(1):A652. <https://doi.org/10.4102/Jamba.V11i1.652>
- Nciizah T (2014) The contribution of small grain production to food security in drought prone areas: the case of Zvishavane (2000–2014) A thesis Submitted in Fulfilment of the Requirements for the Degree of Master of Arts in Development Studies at Midlands State University
- Nciizah E. (2019). Understanding climate change and rural livelihoods in Zimbabwe: adaptation by communal farmers in Ngundu, Chivi District, A thesis Submitted in Fulfilment of the Requirements for the Degree of Doctor Philosophy of Rhodes University
- Oakland Institute and The Alliance For Food Sovereignty In Africa (AFSA) (Undated). [www.oaklandinstitute.org](http://www.oaklandinstitute.org), [www.afsafrica.org](http://www.afsafrica.org)
- OCHA (2012) Midlands province – natural farming regions. <http://ochaonline.un.org/zimbabwe>
- Okonya JS, Syndikus K, Kroschel J (2013) Farmers' perception of and coping strategies to climate change: evidence from six agro-ecological zones of Uganda. Received: OnlinePublished: July15, 2013. <https://doi.org/10.5539/jas.v5n8p25>
- Orr A, Mwema C, Gierend A, Nedumaran S (2016) Sorghum and millets in Eastern and Southern Africa. Facts, trends and outlook. Working paper series no. 62. ICRISAT research program, markets, institutions and policies. Patancheru 502 324. International Crops Research Institute for the Semi-Arid Tropics, Telangana. 76 Pp
- Rukuni M, Tawonezvi P, Eicher C, Munyuki-Hungwe M, Matondi P (2006) Zimbabwe's agricultural revolution revisited, University of Zimbabwe Publications. Harare, Zimbabwe
- Sharma KK, Crouch JH, Seetharama N, Hash CT (2002) Applications of biotechnology for crop improvement: prospects and constraints. *Vitro Cell Dev Biol—Plant* 163:381–395
- Simba F, Chikodzi D, Murwendo T (2012) Climate change scenarios, perceptions and crop production: a case study of semi-arid Masvingo province in Zimbabwe. *J Earth Sci Clim Change* 3:124. <https://doi.org/10.4172/2157-7617.1000124>
- Sukume C, Makudze E, Mabeza-Chimedza R, Zitsanza N (2000) Comparative economic advantage of crop production in Zimbabwe. Technical paper no. 99 Department of Agricultural Economics and Extension. University of Zimbabwe, Harare
- Taylor JRN (2003). Overview importance of sorghum in Africa [Online]. Available from: <http://www.sciencedirect.com/science?>
- Taylor JR, Schober TJ, Bean S (2006). Novel and non-food uses for sorghum and millets. *J Cereal Sci* 44:252–271
- The Chronicle (2020) Promotion of small grains pays dividends for farmers: [Chronicle.co.zw](http://Chronicle.co.zw)
- UNDP (2018a) Barrier analysis of small grains value chain in Zimbabwe, Technical Notes Series No. 3
- UNDP (2018b) Emerging solutions in small grains value chain in Zimbabwe, Technical Notes Series No. 4

- Zimbabwe Agricultural Sector Survey (2019) Edited by Mutenga T, The State of Zimbabwe's Agricultural Sector Survey 2019, Harare
- Zimbabwe Vulnerability Assessment Committee (ZimVAC) Market Assessment Report (2015) Food and Nutrition Council at SIRDC, Hatcliffe, Harare, Zimbabwe
- Zimbabwe Vulnerability Assessment Committee (ZimVAC), Rural Livelihoods Assessment (2016) Food and Nutrition Council (FNC) at SIRDC, Hatcliffe, Harare, Zimbabwe

**Open Access** This chapter is licensed under the terms of the Creative Commons Attribution 4.0 International License (<http://creativecommons.org/licenses/by/4.0/>), which permits use, sharing, adaptation, distribution and reproduction in any medium or format, as long as you give appropriate credit to the original author(s) and the source, provide a link to the Creative Commons license and indicate if changes were made.

The images or other third party material in this chapter are included in the chapter's Creative Commons license, unless indicated otherwise in a credit line to the material. If material is not included in the chapter's Creative Commons license and your intended use is not permitted by statutory regulation or exceeds the permitted use, you will need to obtain permission directly from the copyright holder.





# Constraints to Farmers' Choice of Climate Change Adaptation Strategies in Ondo State of Nigeria

# 32

George Olanrewaju Ige, Oluwole Matthew Akinragbe,  
Olalekan Olamigoke Odefadehan, and Opeyemi Peter Ogunbusuyi

## Contents

Introduction .....	602
Background .....	602
Description of the Study Area and Methodology .....	604
Study Area .....	604
Research Methods .....	604
Limitations of the Study .....	605
Results and Discussion .....	606
Socio-Economic Characteristics of the Respondent .....	606
Constraints to Choice of Adaptation Strategies Used by the Respondents .....	609
Relationship Between Some Socioeconomic Characteristic of the Respondents and Constraints to Choice of Adaptation Strategies .....	613
Conclusions .....	613
References .....	614

## Abstract

Nigeria being dependent on rain-fed agriculture and with low level of socio-economic development is highly affected and vulnerable to climate change. It

This chapter was previously published non-open access with exclusive rights reserved by the Publisher. It has been changed retrospectively to open access under a CC BY 4.0 license and the copyright holder is "The Author(s)". For further details, please see the license information at the end of the chapter.

G. O. Ige (✉) · O. M. Akinragbe · O. O. Odefadehan  
Department of Agricultural Extension and Communication Technology, School of Agriculture and Agricultural Technology, Federal University of Technology, Akure, Nigeria  
e-mail: [igego@futa.edu.ng](mailto:igego@futa.edu.ng); [omakinnagbe@futa.edu.ng](mailto:omakinnagbe@futa.edu.ng); [olalekanodefadehan@gmail.com](mailto:olalekanodefadehan@gmail.com)

O. P. Ogunbusuyi  
Department of Agricultural and Resource Economics, School of Agriculture and Agricultural Technology, Federal University of Technology, Akure, Nigeria  
e-mail: [ogunbusuyiopeyemi@gmail.com](mailto:ogunbusuyiopeyemi@gmail.com)

is crucial for farmers to adapt to the never ending climate change. However, there are constraints to adaptation strategies used by the farmers. This study therefore identified some of the constraints to the farmers' choice of climate change adaptation strategies in Ondo State, Nigeria. A multistage sampling procedure was used in selecting one hundred and sixty respondents for the study. Data collected with a well-structured interview schedule were analyzed using frequency, percentage, and mean statistic, while Pearson Product Moment Correlation was used to test hypothesis. Crops competing for nutrient, inadequate access to climate information, inadequate finance, scarcity of labor, and inadequate farm input supplies were among the major constraints to choice of climate change adaptation strategies used by the respondents. The study recommended that weather forecast information should be published and made available to the farmers through agricultural extension agents. Training on how to improve mixed cropping technique and avoid vulnerability should be pursued.

---

**Keywords**

Constraints · Climate change · Adaptation strategies · Farmers · Farm-inputs

---

## Introduction

### Background

Climate change is one of the major sources of risk in agriculture (De and Badosa 2015). In sub-Saharan Africa, it is set to hit the sector severely and cause suffering, particularly for smallholder farmers. The potential of agriculture to generate a more pro-poor growth process depends on the creation of new market opportunities that most benefit the rural poor (Culas and Hanjra 2011). This could be attributed to the fact that climate change affects the two most important direct agricultural production inputs: precipitation and rainfall (Deschenes and Greenstone 2006). Climate change also indirectly affects agriculture by influencing emergence and distribution of crop pests and livestock diseases, exacerbating the frequency and distribution of adverse weather conditions, reducing water supplies for irrigation, and enhancing severity of soil erosion (IPCC 1998).

Nigeria, which is dependent on rain-fed agriculture together with low level of socio economic development, is highly affected and vulnerable to climate change. Thus, a better understanding of farmers' concerns and their perception of climate change is crucial to design effective policies for supporting successful adaptation of the agricultural sector (Kumar and Sidana 2018). Adaptation helps farmers achieve their food, income, and livelihood security objectives in the face of changing climatic and socioeconomic conditions, including climate variability, extreme weather conditions such as droughts and floods, and volatile short-term changes in



local and large-scale markets (Kandlinkar and Risbey 2000). Farmers can reduce the potential damage by making tactical responses to these changes.

Adaptation strategies which are applicable to climate change are not exhaustive. These strategies vary with scope, approach, purpose, use, application, and timing. The choice of adaptation methods by farmers depends on various social, economic, and environmental factors (Bryan et al. 2013). Adaptation is therefore important for finding ways to help farmers adapt in the rural economies of Africa by providing effective adaptation strategies such as the use of irrigation facilities, improved and resistant crop varieties, modern farm mechanization among others in combating the adverse effect of climate change.

However, there are constraints to adaptation strategies of the farmers, which vary across countries. Satishkumar et al. (2013) categorized constraints faced by farmers in India into personal, institutional, and technical constraints. Small scale fragmented land holdings, low literacy level, inadequate knowledge of how to cope or build resilience, and traditional beliefs were categorized as personal constraints; poor access to extension services, poor access to information sources, and nonavailability of institutional credit were categorized as institutional constraints, while non-availability of drought tolerant varieties, lack of access to weather forecasting information, dependent on monsoon irrigation, high cost of irrigation facilities, shifting of cropping pattern, and lack of technical know-how were categorized as technical constraints.

Fagariba et al. (2018) ranked the constraints affecting farmers' efforts to curb the impact of climate change in Northern Ghana. The study reported unpredictable weather conditions to be the most serious constraint to climate change adaptation strategies. Inadequate government support, lack of access to weather information, land tenure issues, high cost of input, inadequate extension officers, lack of formal education, and poor soil fertility were the other constraints. Otitoju and Enete (2016) grouped the constraints to the use of adaptation strategies among food crop farmers in South-western Nigeria into four. The groups include public, institutional, and labor constraints; land, neighborhood norms, and religious beliefs constraints; high cost of inputs, technological and poor information on early warning systems constraints; and far farm distance, poor access to climate change adaptation information, off-farm job, and credit constraints. Evers and Pathirana (2018) submit that greater communication, cooperation, and coordination of both policy and scientific work that cut across both disciplinary and geographical boundaries are needed to help reduce uncertainties in future climate projections and inform adaptation decisions.

As site-specific issues require site-specific knowledge, it is very important, therefore, to clearly understand what is happening at community level, because farmers are the most climate vulnerable group. In the absence of such location specific studies, it is difficult to fine tune interventions geared towards alleviating the constraints faced by the local farmers. It is on this note that this study seeks to know the socio economic characteristics of the farmers' and also identify the constraints to farmers' choices of climate change adaptation strategies in the study area.

## Description of the Study Area and Methodology

### Study Area

The study was carried out in Ondo State, one of the 36 states in Nigeria, and a member of the Niger Delta commission (NDDC) in Nigeria. Ondo State was created on third of February 1976 from the former western state. It originally included what is now Ekiti state, before the separation in 1996 (ODGS 2016). It is bounded in the North West by Ekiti State, west central by Osun State, South East by Ogun State, South East by Edo and Delta states, and the South by the Atlantic Ocean. The state lies between latitude  $5^{\circ} 45'$  and  $8^{\circ} 15'$  north and longitude  $4^{\circ} 45'$  and  $6^{\circ} 05'$  east. Its land area is about 15,500 square kilometers (ODGS 2016).

Ondo State's climate is of two distinct seasons (wet and dry season). In the south, the mean monthly temperature is  $27^{\circ}\text{C}$  with a mean monthly range of  $2^{\circ}\text{C}$ , while mean relative humidity is over 75%. However, in the northern part of the state, the mean monthly temperature and its range are about  $30^{\circ}\text{C}$  and  $6^{\circ}\text{C}$ , respectively. The mean monthly relative humidity is less than 70%. Also, the mean annual total rain fall exceed 2000 mm. However, in the northern part, there is marked dry season from November to march when little or no rain fall, hence, the total annual rain fall in the North drops considerably to about 1800 mm (Fasina et al. 2016; ODSG 2016).

The natural vegetation is the high forest, composed of many varieties of hardwood timber such as *Melicia excelsa*, *Antaris toxicaria*, *Lophira alata*, *Terminalia superba*, and *Symphonia globulinifera*. An important aspect of vegetation of the state is the prevalence of tree crops. The major tree crops include cocoa, kola, rubber, coffee, oil palms, fruits, and citrus (Institute of Food Security, Environmental Resource and Agricultural Research (IFSERAR) 2010). Ondo state is predominantly an agricultural state with over 60% of its labor force deriving their income from farming. It is the leading Cocoa producing state in Nigeria. Other agricultural products include yam, cassava, cocoyam, plantain; thus, the state can support the cultivation of a large variety of crops. It also has the longest coastline in the Country which favor fishing activities in the riverine areas (IFSERAR 2010). The population of the study includes all arable crop farmers in Ondo State, Nigeria.

### Research Methods

#### Study Site Selection and Sampling Methods

A multistage sampling procedure was used in selecting the respondents for this study. In the first stage, two out of the three senatorial districts in the state were randomly selected. The selected senatorial districts are Ondo Central and Ondo North. The second stage involved a random selection of two (2) Local Government Areas (LGAs) from each of the two selected senatorial districts. The selected LGAs

are: Akure South, Ifedore, Ose, and Owo LGAs. The third stage involved purposive selection of four (4) villages, based on the predominance of arable crop farming in the LGAs, making a total of sixteen (16) villages. In the final stage, ten arable crop farmers were randomly selected. Thus, a total of one hundred and sixty (160) respondents constituted the sample size for the study. Data were collected with the aid of a well-structured interview schedule.

## Data Source and Collection Method

### Data Analysis

Data analytical techniques that were used in achieving the objectives for this study are descriptive statistics. They include frequency counts, percentage and mean.

The socio-economic characteristics of the farmers were analyzed using frequency, percentage, and mean statistic. To identify the constraints to choice of adaptation strategies used by the respondents, a list of possible constraints were made available for the farmers to tick on a three-point Likert-type scale of major constraint, minor constraint, and not a constraint, with the value of 2, 1, and 0, respectively. These values were added up to 3 and divided by 3 to get a mean value of 1. Any variables with mean value greater than or equals to 1 imply that they are constraints to climate change adaptation, while mean value of less than 1 implies that they are not a constraint. Any variable with a mean value of greater than or equals to 1.5 are major constraints. The responses were analyzed using mean statistic.

**Hypothesis  $H_0$ :** There is no significant relationship between some socio economic characteristics of the respondents and constraints to choice of adaptation strategies used by the respondents. This was tested using the Pearson Product Moment Correlation (PPMC).

## Limitations of the Study

The study covered only four (4) LGAs out of the eighteen (18) LGAs in the state. Only one hundred and sixty respondents out of several hundred thousands of arable crop farmers in the state were included in the study. This was due to the paucity of funds to carry out the study. A funded research can cover a larger sample for a similar study in the future. Furthermore, access to some farmers was very difficult due to bad access roads, which is a feature of many rural communities in Nigeria. Responses gotten from the respondents were based on memory recall which may not be perfectly and correctly stated. The effects of this limitation were minimized by repeating some questions but reframed, so as to confirm the response to the previous question. Uncooperative attitude of some farmers in terms of giving accurate information about themselves was another limitation. These limitations propelled the researchers to put extra effort to collect reliable data, which will be affected by the identified limiting factors.

## Results and Discussion

### Socio-Economic Characteristics of the Respondent

The distribution of respondents by their socio-economic characteristics is presented in Table 1. It was revealed that 38.8% were between 50 and 59 years of age, 24.5% were between 40 and 49 years, 20.7% were between 60 and 69 years, while 10.5% of the respondents were above 70 years of age. Also, 4.9% of the respondents were between 30 and 39 years, while only 0.6% of the respondents were less than 30 years of age. It was further revealed that the average age of the respondents was 54.6 years. This is an indication that arable crop farmers in the study area are fairly old, although they are still within the active age with the strength and vigor to carry out all the laborious activities involved in agricultural production. This agreed with the findings of Oluwasusi and Tijani (2013), who reported an average age of 53.9 years in a study conducted in Ekiti State, Nigeria.

Farming in the study area was dominated by the males (62.5%), while the female respondents accounted for 37.5% of the respondents. This might be attributed to the laborious nature of all the activities involved in arable crop production/farming in the study area. However, the females were believed to be more involved in the processing and marketing of farm by-products. This agreed with the findings of Ibitoye et al. (2014) who reported that the males dominated agricultural production in a study on the constraints to climate variability adaption among arable crop farmers in Ekiti State, Nigeria.

It was further revealed that majority (87.5%) of the respondents were married, while only 1.9% of them were still single, 6.3% of the respondents were divorced, while 4.4% of them were separated. The fact that majority of the farmers in the study area were married might be a reflection of the strong moral values attached to marriage institution in the study area. This also agreed with the findings of Ibitoye (2012) and Oguntade et al. (2014) who reported in their separate studies that arable crop farmers that are married dominated arable crop farming activities in Nigeria. Majority (62.5%) of the arable crop farmers in the study area were Christians, 32.5% of the respondents were Muslims, while 5.0% of the respondents practiced traditional religion.

Average household size of the respondents was 7 people. It was revealed that majority (71.2%) of the farming households had between 5 and 9 people, while 16.3% had less than 5 people in their household. However, 12.5% of the respondents had 10 people and above in their respective households. The average household size of about 7 people implied that the household size among farming households in the study area is fairly large. However, this is expected to be a very good source of labor (family labor) for their farming activities and it is expected to enhance their level of productivity.

It was observed that 28.1% of the respondents had no formal education, 21.9% completed primary school education, while 15.6% of them completed secondary school education. It was also revealed that 11.3% attempted primary school education, 8.1% of the respondents acquired adult education, 8.1% of the respondents

**Table 1** Socio-economic characteristics of the respondents

Socioeconomic characteristics	Frequency	Percentage (%)	Mean ( $\bar{X}$ )
<b>Age (years)</b>			54.6
<30 years	1	0.6	
30–39 years	8	4.9	
40–49 years	39	24.5	
50–59 years	62	38.8	
60–69 years	33	20.7	
70 years and above	17	10.5	
<b>Sex</b>			
Female	60	37.5	
Male	100	62.5	
<b>Marital status</b>			
Single	3	1.9	
Married	140	87.5	
Widowed	10	6.3	
Divorced	7	4.4	
<b>Religion</b>			
Christian	100	62.5	
Islam	52	32.5	
Traditional	8	5.0	
<b>Household size (number)</b>			7
<5 persons	26	16.3	
5–9 persons	114	71.2	
10 persons and above	20	12.5	
<b>Level of education</b>			
No formal education	45	28.1	
Adult education	13	8.1	
Attempted primary school	18	11.3	
Completed primary school	35	21.9	
Attempted secondary school	13	8.1	
Completed secondary school	25	15.6	
Attempted tertiary education	1	0.6	
Completed tertiary education	10	6.3	
<b>Farming experience (years)</b>			
<10 years	16	10.1	27.5
10–19 years	29	18.1	
20–29 years	41	25.5	
30 years and above	74	46.3	
<b>Farm size (hectares)</b>			
<1	114	71.4	0.91
1–1.99	28	17.5	
2–4.99	16	10	
≥5	2	1.1	

(continued)

**Table 1** (continued)

Socioeconomic characteristics	Frequency	Percentage (%)	Mean ( $\bar{X}$ )
<b>Annual income (₦)</b>			318,595.91
<100,000	14	8.7	
100,000–499,999	113	70.6	
500,000–999,999	28	17.5	
1,000,000 and above	5	3.2	

Source: Field Survey, 2017

attempted secondary school education, while 6.3% of them completed tertiary education. However, 0.6% of the respondents attempted education at tertiary level, without completing it. The fact that only 15.6% of the total respondents completed secondary school education and that only 6.3% of them completed tertiary education is an indication that the level of education among the farmers in the study area is low, in agreement with the findings of Oluwasusi and Tijani (2013). This is believed to have an effect on their level of awareness about climate change effects and also on their level of adoption on strategies in mitigating its effects.

It was further revealed that respondents that had farming experience of 30 years and above constituted 46.3% of the total respondents sampled for this study. However, 25.5% of the respondents were reported to have between 20 and 29 years of farming experience, 18.1% had between 10 and 19 years of farming experience, while only 10.1% of the total respondents had less than 10 years of farming experience. It was also revealed that the average years of farming experience among the arable crop farmers in the study area was 27.5 years. This is an indication that respondents are well experienced in farming activities in the study area. This is expected to enhance the knowledge of the farmers in how to select the appropriate measures to mitigate and cope with the effect of climate change in the study area, in agreement with the findings of Oguntade et al. (2014).

Majority (71.4%) of the respondents had less than one hectare of farm land, 17.5% have between 1–1.99 ha, while 10.0% of the respondents had a farm size of between 2 and 4.99 ha. However, 1.1% of the respondents had a farm size of five hectares and above. The average farm size was approximately one hectare. This suggests that respondents in the study area are small holder arable crop farmers, who practice farming on subsistence basis. This finding is in agreement with the findings of Babatunde (2008), who reported that majority of arable crop farmers in Nigeria are small holder farmers who practice subsistence farming on a small piece of land.

Majority of the respondents (70.6%) earned between ₦100,000 and ₦499,999 per annum, 17.5% of them earned between ₦500,000 and ₦999,999 per annum, while 8.7% of the respondents earned less than ₦100,000 per annum. However, 3.2% of the respondents earned above ₦1,000,000 per annum. The average annual income of the respondents was also revealed to be ₦318,595.91. This suggests that the average annual income of the respondents was fairly low. This could, however, be attributed to the fact that the arable crop farmers in the study are operating on a subsistence scale, with majority of them farming on less than one hectare of land as reported

earlier. The low income earned by the arable crop farmers might equally be due to low output that usually occurs as a result of the adverse effects of climate change. This is in agreement with the findings of Falola et al. (2012); also, low income earned by the arable crop farmers may also be as a result of extra costs incurred by the arable crop farmers in an attempt to mitigate the adverse effects of climate change.

## Constraints to Choice of Adaptation Strategies Used by the Respondents

Table 2 presents the constraints to choice of adaptation strategies used by the respondents in the study area. It was revealed that inadequate finance ( $\bar{X} = 1.8$ ), scarcity of labor ( $\bar{X} = 1.8$ ), and inadequate technical know-how knowledge ( $\bar{X} = 1.7$ ) were the major constraints militating against the choice of irrigation as a coping strategy to the effect of climate change in the study area. The problems of inadequate finance would not enable the arable crop farmers to acquire the necessary irrigation equipment and facilities which might be too expensive for them to acquire from the proceeds from their farming activities. Also, inadequate knowledge and technical know-how in operating the modern irrigation equipment will to a greater extent limit the farmers use of irrigation as an adaptation strategy to the effect of climate change in the study area.

It was further revealed that poor agricultural extension services ( $\bar{X} = 1.6$ ), high cost of fertilizer and other inputs ( $\bar{X} = 1.5$ ), as well as pest and diseases ( $\bar{X} = 1.6$ ) were the major constraints militating against the choice of planting of cover crops as a coping strategy to combat the effect of climate change in the study area. This implied that inadequate dissemination of information as a result of poor extension services limits the level of awareness of the farmers on the potentials the planting of cover crops has in reducing the effect of adverse climatic condition (e.g., drought) on arable crops in the study area. This is in conformity with the findings of Satishkumar et al. (2013) Also, high cost of fertilizer and other inputs required in planting and maintaining cover crops constrained some of the arable crop farmers to use the planting of cover crops to combat the adverse effect of climate change in the study area. This is in line with the findings of Otitoju and Enete (2016). High possible incidence of pest and disease infestation associated with the use of cover crops can also be a constraint to the use of cover crop in mitigating the effects of climate change in the study area.

It was further revealed that the major constraints militating against the use of weather forecasting as an adaptation strategy against the effects of climate change included inadequate access to climate information ( $\bar{X} = 1.8$ ). This corroborates the findings of Fagariba et al. (2018). This suggests that inadequacy of climatic information available to the arable crop farmers in terms of accuracy and consistency of metrological information greatly constrained them from choosing weather forecasting as an adaptation strategy against the effects of climate change. Also, the high cost of accessing the weather forecast information as well as the incompatibility of such information constrained the farmers in adopting weather forecasting as a reliable means of coping with the effect of climate change in the study area.

**Table 2** Constraints to choice of adaptation strategies used by the respondents

Constraints to adaptation strategies	Major constraints (2)	Minor constraints (1)	Not a constraint (0)	Mean ( $\bar{X}$ )	Std. dev.
<b>Irrigation</b>					
Inadequate finance	38 (86.4)	4 (9.1)	2 (4.5)	1.8*	0.5
Land related issue	35 (79.5)	1 (2.3)	8 (18.2)	1.6*	0.8
Scarcity of labor	37 (84.1)	6 (13.6)	1 (2.3)	1.8*	0.4
Inadequate technical know-how knowledge	36 (81.8)	2 (4.5)	6 (13.6)	1.7*	0.7
<b>Planting of cover crops</b>					
Poor agricultural extension services	38 (77.6)	3 (6.1)	8 (16.3)	1.6*	0.8
Farm distance	30 (61.2)	4 (8.1)	15 (30.7)	1.3	0.4
High cost of fertilizer and other inputs	34 (69.4)	6 (12.2)	9 (18.4)	1.5*	0.8
Pest and diseases	38 (76.0)	4 (8.0)	8 (16.0)	1.6*	0.8
<b>Use of weather forecasting</b>					
Inadequate access to climate information	30 (83.3)	3 (8.3)	3 (8.3)	1.8*	0.6
Cultural incompatibility	26 (72.2)	6 (16.7)	4 (11.1)	1.6*	0.7
It is expensive and depends on technologies	28 (77.8)	2 (5.6)	6 (16.7)	1.6*	0.8
Inconsistent government policies	22 (62.9)	5 (14.3)	8 (22.9)	1.4	0.6
<b>Use of resistant crop varieties</b>					
Availability of the varieties	44 (88.0)	1 (2.0)	5 (10.0)	1.8*	0.6
Cost of the varieties	41 (83.7)	–	8 (16.3)	1.7*	4.1
Farm distance	32 (65.3)	6 (12.2)	11 (22.4)	1.4	0.8
Off farm job and credits	34 (70.8)	5 (10.4)	9 (18.8)	1.5*	0.8
<b>Change in planting date</b>					
Poor agricultural program and service delivery	50 (82.0)	4 (6.6)	7 (11.5)	1.7*	0.7
Neighborhood norms and religious believes	29 (47.5)	11 (18.5)	21 (34.4)	1.1	0.9
Reduction in output	41 (67.2)	9 (14.8)	11 (18.0)	1.5*	0.8
Inadequate access to hybrid seeds	50 (82.0)	6 (9.8)	5 (8.2)	1.7*	0.6
<b>Change in harvest date</b>					
Inaccurate agro-metrological information	19 (79.2)	1 (4.2)	4 (16.7)	1.6*	0.8
Time of dissemination of agro-meteorological information	17 (70.8)	3 (12.5)	4 (16.7)	1.5*	0.8
Poor storage and processing facilities	16 (66.7)	2 (8.3)	6 (25.0)	1.4	0.9
High cost of farm operations	14 (58.3)	2 (8.3)	8 (33.3)	1.3	0.9

(continued)



**Table 2** (continued)

Constraints to adaptation strategies	Major constraints (2)	Minor constraints (1)	Not a constraint (0)	Mean ( $\bar{X}$ )	Std. dev.
<b>Use of sand bags by river banks</b>					
High cost of labor	9 (100.0)	–	–	2.0*	0.0
Inadequate finance and credit facilities	9 (100.0)	–	–	2.0*	0.0
Drudgery of making the sand bags	8 (88.9)	1 (11.1)	–	1.9*	0.3
Longer time in making the sand bags	8 (88.9)	–	1 (11.1)	1.8*	0.7
<b>Use of mulching materials</b>					
Over grazing of the land	25 (39.1)	6 (9.4)	33 (51.6)	0.9	0.5
Urbanization	21 (31.8)	9 (13.6)	36 (54.5)	0.8	0.9
High cost of labor in applying the mulching material	51 (73.3)	11 (16.7)	4 (6.1)	1.7*	0.6
Durability of the mulching materials	29 (44.6)	21 (32.3)	15 (23.1)	1.2	0.8
<b>Mixed cropping</b>					
Vulnerability to pest and diseases	42 (52.5)	11 (13.8)	27 (33.8)	1.2	0.9
Crops competing for nutrient	48 (60.8)	17 (21.5)	14 (17.7)	1.4	0.8
Depletion of the soil nutrient	38 (48.1)	17 (21.5)	24 (30.4)	1.2	0.9
Poor extension delivery services	35 (44.9)	19 (24.4)	24 (30.8)	1.1	0.9
<b>Crop rotation</b>					
Life span of the crop grown	11 (47.8)	6 (26.1)	6 (26.1)	1.2	0.9
Inadequate farm input supplies	15 (68.2)	6 (27.3)	1 (4.5)	1.6*	0.6
Depletion of the soil nutrient	8 (36.4)	3 (13.6)	11 (50.0)	0.9	0.9
Nonavailability of labor	6 (27.3)	8 (36.4)	8 (36.4)	0.9	0.8
<b>Use of intercropping</b>					
Complication of crop management and harvesting	7 (43.8)	3 (23.1)	3 (23.1)	1.3	0.9
Problem of separating seed crop yield	4 (30.8)	5 (38.5)	4 (30.8)	1.0	0.8
Community customs and laws	3 (25.0)	2 (16.7)	7 (58.3)	0.7	0.9
<b>Nonfarm income diversification</b>					
Government policies due to taxes	1 (8.3)	3 (25.0)	8 (66.7)	0.4	0.9
Inadequate finance and credit	23 (71.9)	1 (3.1)	8 (25.0)	1.5*	0.9
Poor skills	22 (66.7)	4 (3.0)	7 (24.2)	1.5*	0.8
Low wages and poor condition of work	24 (72.7)	1 (3.0)	8 (24.2)	1.5*	0.9

Key: 0–0.9 = Not a Constraint; 1.0–1.4 = Minor Constraint; 1.5 and above = Major Constraint  
 \*denotes major constraints

Note: Values in parenthesis are Percentages

It was further revealed in this study that the major factors militating against the use of resistant crop varieties as an adaptation strategy against the effects of climate change in the study area included nonavailability of the disease resistant varieties ( $\bar{X} = 1.8$ ), high cost of the varieties ( $\bar{X} = 1.7$ ), as well as off farm job and credits of the farmer ( $\bar{X} = 1.5$ ). The high cost, coupled with the unavailability of improved varieties of arable crops that are resistant to pest and diseases, is a major constraint preventing the arable crop farmers from adopting the use of resistant crop varieties to cope with the effect of climate change in the study area. Otitoju and Enete (2016) reported a similar finding.

Poor agricultural program and service delivery ( $\bar{X} = 1.7$ ), inadequate access to hybrid seeds ( $\bar{X} = 1.7$ ), and reduction in output ( $\bar{X} = 1.5$ ) were the major constraints militating against the use of change in planting date as an adaptation strategy against the effects of climate change in the study area. Also, inaccurate agro-metrological information ( $\bar{X} = 1.6$ ), time of dissemination of agro-metrological information ( $X = 1.5$ ), and poor storage and processing facilities ( $\bar{X} = 1.4$ ) were the major constraints militating against the use of change in harvest date as an adaptation strategy to the effects of climate change in the study area. This implied that inaccurate and unseemliness of agro-metrological information greatly constrains the arable crop farmers in the adoption of both change in planting and harvest dates as a coping strategy in combating the effects of climate change in the study area.

It was also observed that major constraints that militated against the use of sand bags by river banks as an adaptation strategy to the effects of climate change in the study area included high cost of labor ( $\bar{X} = 2.0$ ), inadequate finance and credit facilities ( $\bar{X} = 2.0$ ), and drudgery of making the sand bags ( $\bar{X} = 1.9$ ). This implied that the use of sand bags as an adaptation strategy might be very expensive for the arable crop farmers to adopt. Therefore, with the limited finance available to the arable crop farmers, it might be difficult to adopt the use of sand bags as an adaptation strategy to combat the effect of climate change in the study area. Also, drudgery of making the sand bags might be a discouraging factor preventing the farmers from adopting the use of sand bags as an adaptation strategy to combat the effect of climate change in the study area.

Furthermore, high cost of labor in applying the mulching material ( $\bar{X} = 1.7$ ) and the durability of the mulching materials ( $\bar{X} = 1.2$ ) were the major constraining factors militating against the use of mulching materials as an adaptation strategy against the effects of climate change in the study area. This suggests that the higher the cost of labor in applying the mulching materials, the lesser the adoption of mulching materials as an adaptation strategy in combating the effect of climate change in the study area. It was further observed that the constraints militating against the use of mixed cropping system as an adaptation strategy in the study area were minor ones. They included crops competing for nutrient ( $\bar{X} = 1.4$ ), vulnerability to pest and diseases ( $\bar{X} = 1.2$ ), and depletion of the soil nutrient ( $\bar{X} = 1.2$ ). This might be attributed to the fact that the practice of mixed cropping increase the vulnerability of the crops planted to different pests and diseases. Also, practicing mixed cropping will make the different crops compete for the limited available nutrients, and ultimately this will lead to quick depletion of soil nutrients.

**Table 3** PPMC Correlation between some socioeconomic characteristic of the respondent and constraints to choice of adaptation strategies

Variable	r-value	p-value	Decision
<b>Age</b>	-0.028	0.729	Not significant
<b>Household size</b>	0.122	0.128	Not significant
<b>Level of education</b>	-0.074	0.354	Not significant
<b>Farming experience (years)</b>	0.126	0.116	Not significant
<b>Farm size (plots)</b>	0.170 <sup>a</sup>	0.034	Significant

<sup>a</sup>Correlation is significant at the 0.05 level (2-tailed)

Furthermore, the major constraining factor against the use of crop rotation as an adaptation strategy to the effects of climate change was observed to be inadequate farm input supplies ( $\bar{X} = 1.6$ ), while the life span of the crop grown ( $\bar{X} = 1.2$ ) was a minor constraint. Moreover, there were only minor constraining factors against the use of intercropping as an adaptation strategy to the effects of climate change in the study area. They include complication of crop management and harvesting ( $\bar{X} = 1.3$ ) and problem of separating seed crop yield ( $\bar{X} = 1.0$ ). However, inadequate finance and credit ( $\bar{X} = 1.5$ ), poor skills ( $\bar{X} = 1.5$ ), and low wages and poor condition of work ( $\bar{X} = 1.5$ ) were the major constraints preventing the arable crop farmers from choosing nonfarm income diversification as an adaptation strategy against the effects of climate change in the study area.

### Relationship Between Some Socioeconomic Characteristic of the Respondents and Constraints to Choice of Adaptation Strategies

Table 3 presents the result of the null hypothesis which states that "There is no significant relationship between some socioeconomic characteristic of the respondent and the constraints to choice of adaptation strategies used by the respondent." It was revealed that the farm size of the respondent was the only socioeconomic characteristic that had a strong positive correlation ( $r = 0.170$ ;  $p = 0.034$ ) with the constraints to choice of climate change adaptation strategies used by the respondent in the study area. This suggests that constraints to choice of climate change adaptation strategies increases with increase in the farm size, implying that respondents with larger arable crop farms were faced with more constraints to choice of climate change adaptation strategies in the study area compared with those with smaller farm size.

### Conclusions

From the findings, it can be concluded that many of the farmers, who happened to be males, fairly old, and are arable crop farmers. The major constraints to the various adaptation strategies were inadequate finance, scarcity of labor, poor agricultural extension services, inadequate access to climate information, nonavailability of

resistant varieties, poor agricultural program, inaccurate agro-meteorological information, high cost of labor, low wages and poor condition of work, complication of crop management and harvesting, inadequate farm input supplies, and crops competing for nutrient. These constraints have hindered arable crop farmers in their choice of the identified adaptation strategies in coping with the adverse effect of climate change; it is also reduced farmers level of food production in a bid to ensure food security in the society and also elevate their own economic standard. Hence, respondents with larger arable crop farms were faced with more constraints to choice of climate change adaptation strategies in the study area compared with those with smaller farm size.

It is recommended that weather forecast information should be published and be made available to the farmers for them to be aware of situations to be prepared for at the beginning of each production season through agricultural extension agents. Also, training on how to improve the mixed cropping technique and avoid vulnerability should be pursued. This could also avert crop failure.

---

## References

- Babatunde RO (2008) Income inequality in rural Nigeria; evidence from farming household data. *Aust J Basic Appl Sci* 2(1):134–135
- Bryan E, Ringer C, Okoba B, Roncoli C, Silvestri S, Herrero M (2013) Adapting agriculture to climate change in Kenya: household strategies and determinants. *J Environ Manage* 114:26–35
- Culas RJ, Hanjra MA (2011) Some explorations into Zambia's post-independent policies for food security and poverty reduction. In: Contreras LM (ed) *Agricultural policies: new developments*. Nova Science Publishers, Hauppauge
- De UK, Badosa K (2015) Crop diversification in Assam and use of modern inputs under changing climate conditions. *Journal of Climatology and Weather Forecasting* 2(2):1–14
- Deschenes O, Greenstone M (2006) The economic impacts of climate change: evidence from agricultural output and random fluctuations in weather. *Am Econ Rev* 97(1):354–385
- Evers J, Pathirana A (2018) Adaptation to climate change in the Mekong River basin: introduction to the special issue. *Clim Change* 149:1–11
- Fagariba CJ, Song S, Baoro SKGS (2018) Climate change adaptation strategies and constraints in northern Ghana: evidence of farmers in Sissala West District. *J Sustain* 10(5):1–18
- Falola A, Fakayode SB, Akangbe JA, Ibrahim HK (2012) Climate change mitigation activities and determinants in the Rural Guinea Savannah of Nigeria. *Sustain Agric Res* 1(2). pp16
- Fasina OO, Ibitoye AL, Ibitoye O (2016) Determinants of change in work values in rural Nigeria: evidence from Ondo state. *J Cult Soc Dev* 24:20–27
- Ibitoye O (2012) Income inequality among arable crop farming households in rural and urban areas of Ekiti state, Nigeria. Unpublished M. Tech. Thesis in the Department of Agricultural and Resource Economics, Federal University of Technology, Akure
- Ibitoye O, Ogunyemi AI, Ajayi JO (2014) Constraints to climate variability adaption among arable crop farmers in Ekiti state, Nigeria. Paper presented at the annual national conference of Nigerian Association of Agricultural Economists (NAAE). Theme: climate change, agriculture and food security in Nigeria. The Federal University of Technology, Akure. 24th – 27th, February, 2014
- Institute for Food Security and Environmental Research (IFSERAR) (2010) Impact of climate change on peoples livelihood, wildlife resources and food security in Southwest Nigeria. Annual research report submitted to Institute for Food Security and Environmental Research (IFSERAR), University of Agriculture, Abeokuta

- Intergovernmental Panel on Climate Change (IPCC) (1998) The IPCC second assessment: climate change 1998. Cambridge University Press, Cambridge
- Kandlinkar M, Risbey J (2000) Agricultural impacts of climate change: if adaptation is the answer, what is the question? *Clim Change* 45:529–539
- Kumar S, Sidana BK (2018) Farmers' perceptions and adaptation strategies to climate change in Punjab agriculture. *Indian J Agric Sci* 88(10):1573–1581
- Ogutade AE, Ibitoye O, Ogunyemi AI (2014) Farmers' perception of climate variability and adaptation strategies for sustainable rice production in Ekiti state, Nigeria. Paper presented at the annual national conference of Nigerian Association of Agricultural Economists (NAAE). Theme: climate change, agriculture and food security in Nigeria. The Federal University of Technology, Akure. 24th – 27th, February, 2014
- Oluwasusi JO, Tijani SA (2013) Farmers' adaptation strategies to the effect of climate variation on yam production: a case study in Ekiti state, Nigeria. *Agrosearch* 13(2):20–31
- Ondo State Government (ODSG) (2016). [www.ondostate.gov.ng/new/people.php?festId=1](http://www.ondostate.gov.ng/new/people.php?festId=1). Date accessed: December, 2017
- Otitoju MA, Enete AA (2016) Climate change adaptation: uncovering constraints to the use of adaptation strategies among food crop farmers in south-west, Nigeria using principal component analysis (PCA). *Cogent Food Agric* 2:1. <https://doi.org/10.1080/23311932.2016.1178692>
- Satishkumar N, Tevari P, Singh A (2013) A study on constraints faced by farmers in adapting to climate change in rain-fed agriculture. *J Hum Ecol* 44(1):23–28

**Open Access** This chapter is licensed under the terms of the Creative Commons Attribution 4.0 International License (<http://creativecommons.org/licenses/by/4.0/>), which permits use, sharing, adaptation, distribution and reproduction in any medium or format, as long as you give appropriate credit to the original author(s) and the source, provide a link to the Creative Commons license and indicate if changes were made.

The images or other third party material in this chapter are included in the chapter's Creative Commons license, unless indicated otherwise in a credit line to the material. If material is not included in the chapter's Creative Commons license and your intended use is not permitted by statutory regulation or exceeds the permitted use, you will need to obtain permission directly from the copyright holder.





# Maize, Cassava, and Sweet Potato Yield on Monthly Climate in Malawi

# 33

Floney P. Kawaye and Michael F. Hutchinson

## Contents

Introduction .....	618
Maize, Cassava, and Sweet Potato Growth .....	619
Methodology .....	620
GROWEST Analysis .....	620
Results .....	623
Trends in Production and Yield of Maize, Cassava, and Sweet Potato .....	623
GROWEST Analyses .....	626
Discussion .....	632
Conclusion .....	634
References .....	635

## Abstract

Climate change and climate variability in Malawi have negatively affected the production of maize, a staple food crop. This has adversely affected food security. On the other hand, there have been increases in growing area, production, yield, consumption, and commercialization of both cassava and sweet potato. Factors behind these increases include the adaptive capacity of these crops in relation to climate change and variability, structural adjustment programs, population growth and urbanization, new farming technologies, and economic development. Cassava and sweet potato are seen to have the potential to contribute to food security and alleviate poverty among rural communities.

This chapter was previously published non-open access with exclusive rights reserved by the Publisher. It has been changed retrospectively to open access under a CC BY 4.0 license and the copyright holder is “The Author(s)”. For further details, please see the license information at the end of the chapter.

F. P. Kawaye (✉) · M. F. Hutchinson (✉)  
Fenner School of Environment and Society, Australian National University,  
Canberra, ACT, Australia  
e-mail: [Floney.Kawaye@anu.edu.au](mailto:Floney.Kawaye@anu.edu.au); [michael.hutchinson@anu.edu.au](mailto:michael.hutchinson@anu.edu.au)

This study used a simple generic growth index model called GROWEST to model observed yields of maize, cassava, and sweet potato across Malawi between 2001 and 2012. The method can be viewed as a hybrid approach between complex process-based crop models and typical statistical models. For each food crop, the GROWEST model was able to provide a robust correlation between observed yields and spatially interpolated monthly climate. The model parameters, which included optimum growing temperatures and growing seasons, were well determined and agreed with known values. This indicated that these models could be used with reasonable confidence to project the impacts of climate change on crop yield. These projections could help assess the future of food security in Malawi under the changing climate and assist in planning for this future.

---

**Keywords**

Climate change · Food security · Maize · Cassava · Sweet potato · Crop yield modelling

---

**Introduction**

Process-based simulation models and statistical models are commonly used to assess the impact of climate variability and climate change on food crop yields (Lobell and Asseng 2017). The former typically have complex plant and environmental data requirements, while the latter can have large uncertainties in fitted parameters that make application to climate change assessment difficult (Schlenker and Lobell 2010; Ray et al. 2019). This chapter examines a hybrid approach that statistically calibrates a simple generic plant growth model, called GROWEST, using spatially distributed yield and monthly climate data. The model parameters are robustly determined and hence able to provide baseline models suitable for assessing the potential yields of maize, cassava, and sweet potato in relation to projected climate change. The GROWEST plant growth index model was originally developed by Fitzpatrick and Nix (1970) and Nix (1981) and has been implemented by Hutchinson et al. (2002). It has been used to develop a global agroclimatic classification that has identified agroclimatic classes for Australia (Hutchinson et al. 2005) that have been used to support a wide variety of ecosystem assessments.

The model is applied to annual yield data for the eight Agricultural Development Divisions (ADDs) across Malawi and corresponding spatially distributed monthly climate data. Spatial climate data were available from 1981 to 2012. The maize analyses were restricted to the years 2006–2012 after the introduction of the Farm Input Subsidy Program (FISP) in 2005/06 which had a significant impact on maize yields. Reliable annual yield data were available for cassava for the period 2001–2011 and for sweet potato for the period 2006–2012. The yield model is based on regressing the logarithms of the observed crop yields on average weekly growth indices of the GROWEST model, with the average taken

over the respective growing season for each crop. Three key parameters of the GROWEST model, the optimum growth temperature and the starting and finishing weeks of the growth season, are tuned to the observed yield data for each crop. The regressions take into account variations in site and management conditions across different ADDs and are extended to take into account systematic increases in yields over time due to plant breeding programs, improvements in growing practice, and carbon dioxide fertilization. Robustly calibrated models are obtained for local, composite, and hybrid maize varieties and for cassava and sweet potato.

---

## Maize, Cassava, and Sweet Potato Growth

As noted by Kawaye and Hutchinson (2018), maize is a staple food crop in Malawi that is grown under both irrigation and rainfed farming systems. However, rainfed farming dominates as it covers about 99% of Malawi's agriculture, mainly on smallholder farms. Kawaye and Hutchinson (2018) further noted that rainfed maize is normally planted between November and December (the start of the rainy season). It grows rapidly during the high rainfall months of January and February and matures by early April. It is harvested in late April or early May. Maize yields in Malawi range from less than 1000 kg to over 4000 kg per hectare, depending on various factors including climate, location, seed variety, fertilizer use, labor, and policy-related factors including access to credit, input and output markets and extension services.

Cassava (*Manihot esculenta* Crantz) is a perennial woody shrub with an edible starchy tuberous root (Mathieu-Colas et al. 2009). Cassava grows under diverse ecological and agronomical conditions. It favors a warm moist climate with mean temperature of 24–30 °C (Nassar 2004; Mkumbira 2002). It can tolerate temperatures from 16 °C to 38 °C (Cock 1984). It does not favor excess soil moisture nor high salt concentrations nor pH above 8 (Nassar 2004; Mkumbira 2002). Cassava is normally planted early in the wet season, usually around mid-November. As a perennial crop, cassava has no definite lifetime or maturation period. After full development of the canopy, root growth slowly decreases and finally stops. This is the maturation point of cassava when maximum or near maximum yield is obtained. Cassava is harvested when the returns for production and utilization are maximized. Thus harvesting can be delayed to well after when the tubers have matured. The optimum time to harvest is 9–12 months (Mathias and Kabambe 2015) depending on various ecological factors such as rainfall, temperature, and soil fertility (Mathieu-Colas et al. 2009; Benesi 2005).

Sweet potato (*Ipomoea batatas* Lam) is an annual crop (Mathieu-Colas et al. 2009). It is widely grown in tropical, subtropical, and temperate areas between 40°N and 32°S. It grows best with air temperatures between 20 °C and 25 °C, and growth is restricted below 15 °C (Ramirez 1992). It can be cultivated across a wide variety of soil types and prefers lightly acid or neutral soils with a pH between 5.5 and 6.5 (Ramirez 1992). Sweet potato is commonly grown as an intercrop with maize and



planted early in the calendar year (FAO 2005). It can also be planted toward the end of the wet season in late April and grown on residual soil moisture. Like cassava, the growth period of sweet potato depends on various ecological factors, but it generally takes 4–5 months to mature (Mathieu-Colas et al. 2009).

---

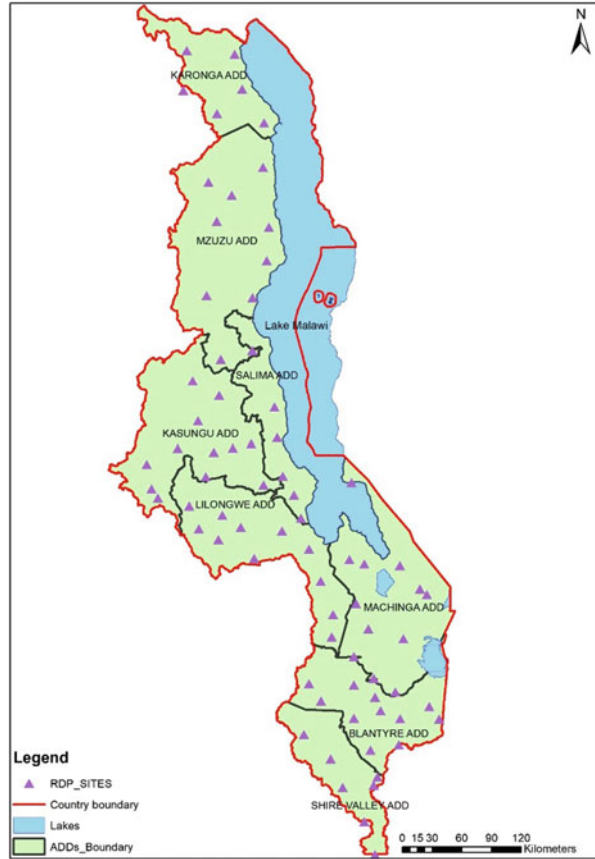
## Methodology

This study modelled the dependence of observed maize, cassava, and sweet potato yields on spatially distributed monthly climate to provide a basis for assessing the impact of projected climate change. The models were constructed by performing multilinear regressions of the logarithms of the observed yields on accumulated outputs from the GROWEST growth index model. The GROWEST model generates a generic, process-based, growth index that depends on weekly or monthly climate with a minimal number of parameters. The growth index varies between 0 (climate totally limiting for growth) and 1 (climate optimal for growth). It is normally assumed to be proportional to the rate of relative increase in plant biomass over time. The growth index is calculated as the product of three separate indices that incorporate the impact of temperature, solar radiation, and modelled soil moisture. The simplicity of the model, and its underlying process basis, makes it well suited to deriving robust calibrations of yield response to climate using yield data limited in quantity or quality. The modelling approach can be seen as a hybrid between complex crop simulation models and statistical analysis of growing season weather variables (Lobell et al. 2011). The critical parameters of the GROWEST model are able to be determined by maximizing the alignment of the GROWEST outputs with the observed crop yields using standard multilinear regression. These regression analyses are extended to take account of observed systematic increases in crop yields over time due to crop breeding programs, improvements in crop management, and possible carbon dioxide fertilization.

## GROWEST Analysis

The models were calibrated on yield data for each ADD over the periods for which both climate and reliable yield data were available, namely, 2006–2012 for the three main varieties of maize, 2001–2011 for cassava, and 2006–2012 for sweet potato. The GROWEST model was applied to monthly climate across all eight ADDs using interpolated monthly climate values at 74 points that approximately equi-sampled the cropping areas across the eight ADDs of Malawi as shown in Fig. 1. The interpolated climate values were obtained using thin plate smoothing splines as provided by the ANUSPLIN Version 4.4 package (Hutchinson and Xu 2013). The output growth indices (GIs) were averaged across each ADD to match the average yields reported for each ADD. The GROWEST model runs on a weekly time step but can be applied to monthly climate data by interpolating monthly data to weekly

**Fig. 1** Seventy-four sites sampling crop growing areas across the eight Agricultural Development Divisions (ADDs) of Malawi



data “on the fly.” It can provide weekly or monthly outputs. Weekly GROWEST outputs were used to obtain finer-scale demarcations of the fitted growing seasons.

A robust regression model was used to determine critical GROWEST parameters for all five crop varieties. Since the GROWEST model describes a relative growth rate, it is natural to formulate the regression model in terms of the natural logarithm of the observed yields. The log formulation has been used in other yield studies (Lobell et al. 2011) and appears to offer a natural separation between site and climatic effects on observed crop yields. A similar approach, but not applying the log transformation, was described by Kawaye and Hutchinson (2018). The regression model for the observed yields  $Z_{ij}$  for year  $Y_i$  and  $ADD_j$  ( $j = 1, \dots, 8$ ) was defined by:

$$\log(Z_{ij}) = a_j + b G_{ij} + c Y_i + \varepsilon_{ij}$$

where  $G_{ij}$  denotes the accumulated growth index for year  $Y_i$  and  $ADD_j$  and  $\varepsilon_{ij}$  denotes a zero-mean random error. The model parameters  $a_j$  and  $b$  were initially

fitted by least squares regression while setting  $c = 0$ . Three additional critical GROWEST parameters were optimized during this initial fitting of the model. These parameters were the optimum temperature of the temperature index, used in calculating the weekly growth index, and the first and last weeks of the fitted growing season, used to define the growing season period. The soil water balance parameters of the GROWEST model were set to default values with the soil water holding capacity set to 150 mm and the soil drying rate set to that of a clay loam soil. The soil water balance is an important component of the growth index, but it is not very sensitive to departures from these default parameter values.

For the three maize varieties, parameter  $c$  was fitted by refitting all parameters using least squares regression. For cassava and sweet potato, parameter  $c$  was fitted by least squares regression on year of the residuals of the data from the initial model. This removed instabilities when all parameters were fitted directly to the cassava and sweet potato data.

The model is robust with just ten parameters. It has a constant dependence of log (yield) on the climate-based accumulated growth index but has a site varying intercept to allow for different site and management conditions across different ADDs. The linear dependence on year via parameter  $c$  allows for underlying improvements in yield due to crop breeding programs, improvements in crop management, and possible carbon dioxide fertilization.

As in Kawaye and Hutchinson (2018), the GROWEST parameters were optimized by automating GROWEST runs and initial regressions using FORTRAN code and standard LINPACK numerical analysis software (Dongarra et al. 1979). Comprehensive analyses of the fitted models were computed using the standard regression package within Excel software. These analyses permitted the identification and removal of a small number of yield data outliers with large standardized residuals. These were associated with anomalies and accounting errors evident in the supporting yield data.

Once outliers were removed and GROWEST optimizations were complete, final comprehensive statistical analyses were computed, making due allowance for the three degrees of freedom associated with estimating the three GROWEST parameters. Standard errors of the fitted GROWEST parameters for the initial regressions were calculated from the diagonal elements of the inverse of the associated Hessian matrix. The Hessian matrix was estimated by calculating second-order finite differences of the residual sums of squares of the model with respect to the three fitted GROWEST parameters.

The final fitted models were applied to the associated growing areas for each ADD and each year. These outputs were aggregated across all ADDs to obtain modelled national yield and production for all crops analyzed. These values were compared with the tabulated national yield and production values to assess the performance of the models at the national scale.

With a view to assessing the potential impacts of climate change, the domains of the fitted temperature indices for each crop were compared with the distributions of the weekly temperatures that occurred across the ADDs over the fitted growing seasons.

## Results

### Trends in Production and Yield of Maize, Cassava, and Sweet Potato

Three main varieties of maize are cultivated in Malawi. These are (i) local (traditional) varieties, (ii) composite varieties, and (iii) hybrid varieties. There are major differences between the yield potentials of these varieties (Giertz et al. 2015; Pauw et al. 2010; Denning et al. 2009; JICAF 2008; Heisey and Smale 1995; Ngwira and Sibale 1986). Local varieties have the lowest yield. They are not subject to yield improvement programs, and harvested seed is recycled from year to year. Composite varieties have higher yields and are often more drought tolerant. They are subject to yield improvement programs but seed can be recycled. Hybrid varieties are the highest yielding and most expensive. They are subject to strictly controlled yield improvement programs, and harvested seed cannot be recycled.

Figure 2 compares growing areas and yields of these three maize varieties from 1984 to 2015. There has only been significant composite maize production since the late 1990s. There has been a steady increase in the area devoted to composite and hybrid varieties and a simultaneous reduction in local maize growing area. This shift has been encouraged by increasing climate stress, such as increasing temperatures, and poor access to farm inputs for local maize production. There is significant year-to-year variation in maize yields, with composite and hybrid yields particularly low from 2001 to 2005. This could be attributed in part to poor climate including low rainfall. The generally higher yields of composite and hybrid maize after 2005 coincide with the introduction of the Farm Input Subsidy Program (FISP). Kawaye and Hutchinson (2018) have presented evidence that FISP has made a significant improvement in composite and hybrid yields since 2006. The analysis of maize yields presented below is therefore restricted to the post FISP years.

Figure 3 shows that cassava and sweet potato production has been generally increasing. There was an abrupt increase in cassava yield in the year 2000 followed by a steady increase, while sweet potato yield has been steadily increasing since the mid-1990s. The abrupt increases in yields in earlier years suggest there have been major improvements in crop-growing practice, and perhaps recording practice, during the 1990s. The steady increase in yields since 2000 reflects increased policy and institutional support, such as the introduction of higher yielding varieties, and improved management practices to diversify the food security basket. The general increase in area under cultivation cassava and sweet potato since 2005 indicates that more farmers have been planting these crops on new land or on land withdrawn from or shared with maize. As noted above, this is due to an increasing reliance on cassava and sweet potato for food security, especially in maize deficit (drought) years.

There was a sharp drop in both yield and production for all crops (maize, cassava, and sweet potato) in the drought year of 2005. For the other years, major variations in production are largely explained by major variations in growing areas as shown in Figs. 2 and 3. On the other hand, minor year-to-year variations in yield are likely to be attributable to year-to-year climatic variations. The differing year-to-year

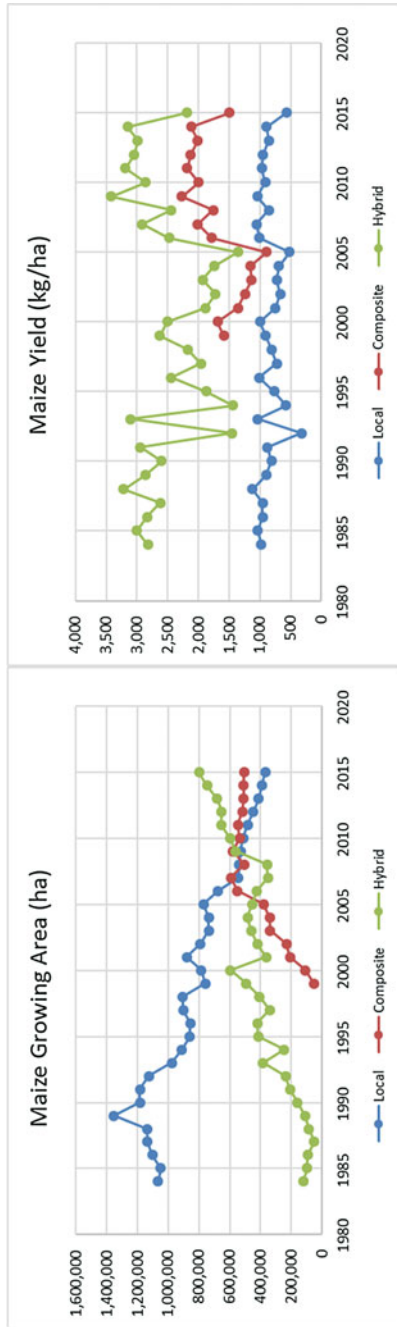
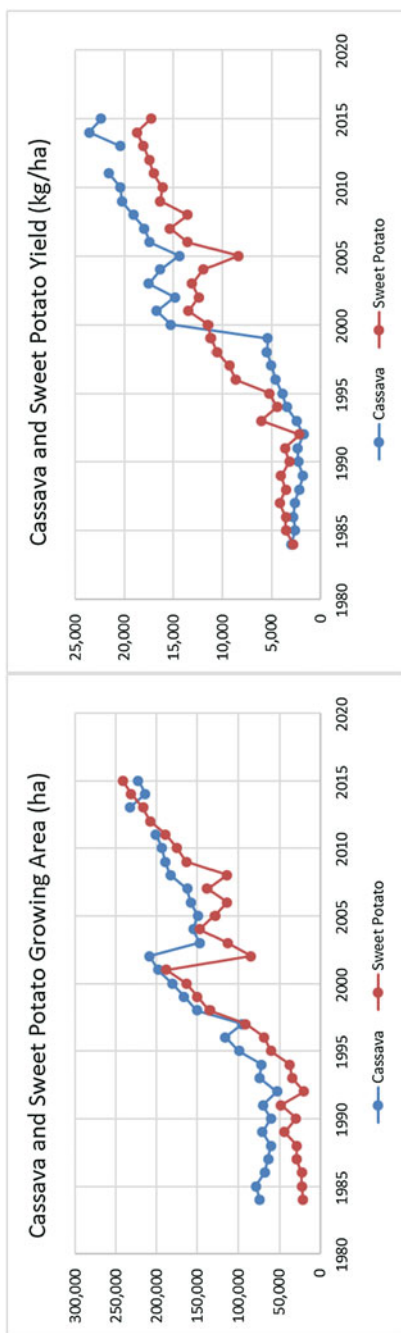


Fig. 2 Growing areas and total yield for local, composite, and hybrid maize from 1984 to 2015



**Fig. 3** Growing areas and total yield of cassava and sweet potato from 1984 to 2015

variations in yield and climate by ADD enable the calibration of the yield responses to monthly climate using the models described here.

## GROWEST Analyses

For each crop the model was initially fitted to the available yield data values with the optimum GROWEST temperature set to a commonly accepted value for each crop. The automated model fitting code was used to adjust the growing season to minimize the standard error of the fitted model. A small number of large standardized residuals for each model were found to correspond to anomalous growing areas or yields for particular RDPs making up the ADD yield data. These large outliers were removed from the analysis, and the three key GROWEST parameters, the optimum growing temperature and the beginning and end of the growing season, were finally optimized by minimizing the residual sum of squares of the fitted model. There were two outliers for each of the three maize analyses, none for the cassava analysis and four for the sweet potato analysis. The values of the three key GROWEST parameters were found to be quite critical to the overall performance of the model. This is in keeping with the finding of Wang et al. (2017) who similarly found that the shape and location of the temperature response function in process-based crop models are critical to their performance. The fitted GROWEST parameters are listed in Table 1.

The fitted starting weeks for the three maize varieties were remarkably similar. Allowing for a period of around 2 weeks from sowing to emergence when the maize plants begin to interact with the atmosphere, the fitted starting weeks corresponded to planting in early December when the wet season is underway. Composite and hybrid maize had fitted growing seasons lasting 13 and 12 weeks, while local maize had a somewhat longer fitted growing season of 15 weeks. These values are all in reasonable agreement with standard management practice. There is systematic variation in the fitted optimum growing temperatures. The fitted temperature for local maize is consistent with documented optimum temperatures of around 26 °C

**Table 1** Optimized GROWEST parameters and mean yield for each crop. Standard errors for each parameter value are provided in parentheses. Weeks are numbered sequentially 1–52 for each year

Crop	Number of data points	Optimum growing temperature (°C)	First week of growing season	Last week of growing season	Mean crop yield (kg/ha)
Local maize	54	24.5 (0.9)	52 (1.0)	15 (1.7)	928
Composite maize	54	28.9 (0.4)	52 (0.8)	13 (1.3)	1,981
Hybrid maize	54	30.2 (0.6)	51 (1.4)	12 (1.5)	2,883
Cassava	88	27.3 (0.6)	47 (2.0)	26 (2.9)	17,984
Sweet potato	52	23.4 (0.7)	7 (2.9)	22 (2.0)	15,920

for maize root growth and grain filling (Sánchez et al. 2014). The fitted temperature for composite maize is consistent with documented optimum temperatures of around 28 °C to 30 °C for maize growth from sowing to anthesis. The slightly higher fitted temperature for hybrid maize is consistent with documented optimum temperatures of around 31 °C for whole plant maize growth. The fitted parameter values indicate that hybrid and composite maize are better adapted to higher temperatures and have shorter growing seasons than the traditional local maize varieties. These are both accepted aims of maize breeding programs.

The fitted growing season for cassava corresponded to planting cassava in mid-November and effective growth terminating by around the end of June. This agrees with the usual growing practice for cassava reported above, with planting time somewhat variable from year to year depending on the arrival of rain and harvesting time variable according to a range of conditions. The latter is consistent with the larger standard error for the finishing week. The fitted optimum growing temperature for cassava is in good agreement with accepted values (Nassar 2004; Mkumbira 2002; Cock 1984).

The fitted growing season for sweet potato corresponded to planting sweet potato in early February and effective growth terminating by around the beginning of June. This is consistent with sweet potato being mainly grown as an intercrop with maize and planted after the maize crop is in place. The fitted optimum growing temperature for sweet potato is also in good agreement with accepted values (Ramirez 1992).

Statistics and key model parameter estimates for each crop are provided in Table 2. All of the model fits were highly statistically significant well beyond the 0.001% level. The performance of the model, with a single coefficient of the accumulated growth index and a different model intercept for each ADD, is remarkably consistent across all crops. Allowing the coefficient of the accumulated growth index to vary from ADD to ADD gave unstable behavior and did not improve the standard error of any model. This confirmed that the relative dependence of crop yield on climate via the accumulated growth index was effectively constant across all sites, justifying the use of a single parameter *b* across all ADDs.

**Table 2** Critical parameter estimates and the percent of yearly variance accounted for the fitted models for all five crops. Standard errors of the fitted parameter values are provided in parentheses

Crop	Number of data points	Model standard error	Parameter <i>b</i>	Parameter <i>c</i>	Percent yearly variance accounted for (%)
Local maize	54	0.141	2.79 (0.55)	0.000 (0.009)	38
Composite maize	54	0.141	3.33 (0.71)	0.013 (0.010)	36
Hybrid maize	54	0.150	2.61 (0.69)	0.032 (0.011)	34
Cassava	88	0.132	2.16 (0.34)	0.025 (0.004)	54
Sweet potato	52	0.070	0.85 (0.17)	0.016 (0.005)	47



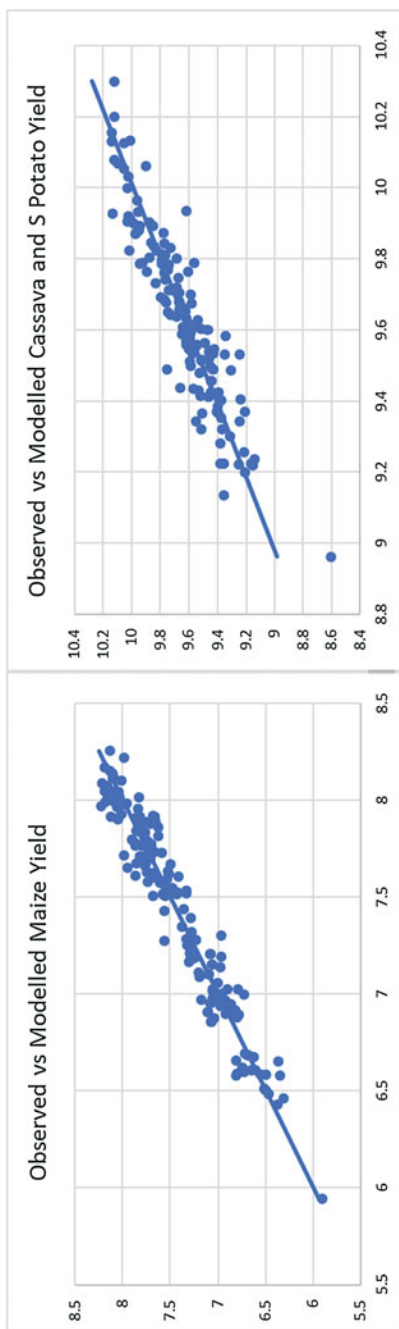
The standard errors of the fitted models are generally no more than 15%, and the fitted values of parameter  $b$  are mostly between 2 and 3 with relatively small standard errors of around 20%. The percent of yearly variation in crop yields explained by the model, after removing variation between sites, ranged from 34% for hybrid maize to 54% for cassava. These values are consistent with the finding of Ray et al. (2015) that climate variation explains around a third or more of crop yield variability.

The smaller value of parameter  $b$  for sweet potato suggests that the model has been less successful in calibrating the full impact of climate on tuber growth. This may have been contributed to by the relatively short data record available for sweet potato and the larger number of apparent accounting errors in the yield data. The variation in planting dates between the traditional early planting date in February and the less common late planting date at the end of the wet season may have also contributed to the less strong fitted dependence on climate via parameter  $b$ . On the other hand, the small model standard error suggests that sweet potato yields may be more stable in relation to climatic variability than cassava. Analysis of yield data over a larger number of years would help to resolve this question.

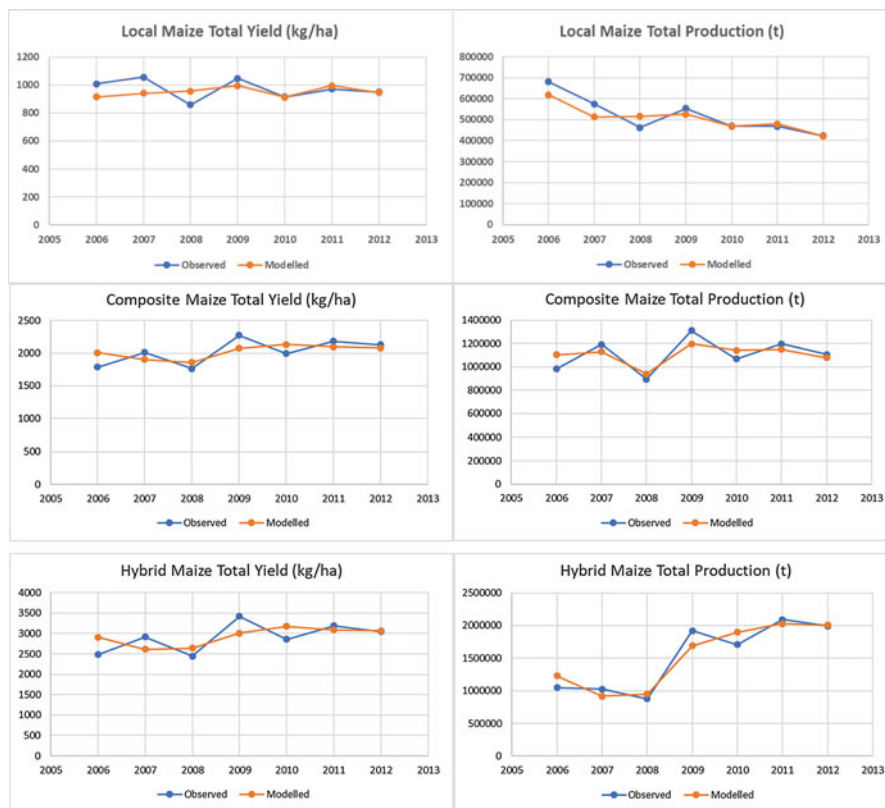
The underlying rates of increase in crop yields are well determined for all crops. The fitted rate of zero for local maize is consistent with no breeding program in place for local maize. The marginally statistically significant rate of increase for composite maize of 1.3% per year is consistent with the modest breeding program in place for composite maize, and the statistically significant rate for hybrid maize of 3.2% per year is consistent with the strong breeding program in place for hybrid maize. The fitted rates of increase of around 2% per year for sweet potato and cassava are consistent with breeding programs being in place for both crops.

Plots of the log (yield) data values versus modelled values are shown in Fig. 4. Individual plots (not shown) of the fitted model, as a function of accumulated GI for each ADD, show considerable scatter of the observed yield data about the fitted model, but the constant slope  $b$  of the fitted line across all ADDs is estimated with reasonable precision, as described above. Likely contributors to the scatter about the fitted model include changes in management practice from year to year, including variations in planting dates, inaccuracies in recording crop yields, and possible misalignments between the locations of the sites sampling climate across the ADDs and the main locations of crop growth. The monthly time scale of the supporting climate data is likely to have made only a small contribution to the scatter about the fitted model given that the largest departures from the fitted model are in every case attributable to clear accounting errors in particular resource development districts (RDDs) within each ADD rather than systematic climate-related anomalies across all RDDs in any ADD.

The smallest observed and modelled values in the plot for cassava are for the drought year 2005 in Shire Valley ADD. The drought was severe in the other southern Machinga and Blantyre ADDs but particularly severe for the Shire Valley ADD (FAO 2005). The plots in Fig. 4 show that the model is able to recognize most drought conditions with reasonable accuracy but somewhat overestimates cassava yield during particularly severe droughts.



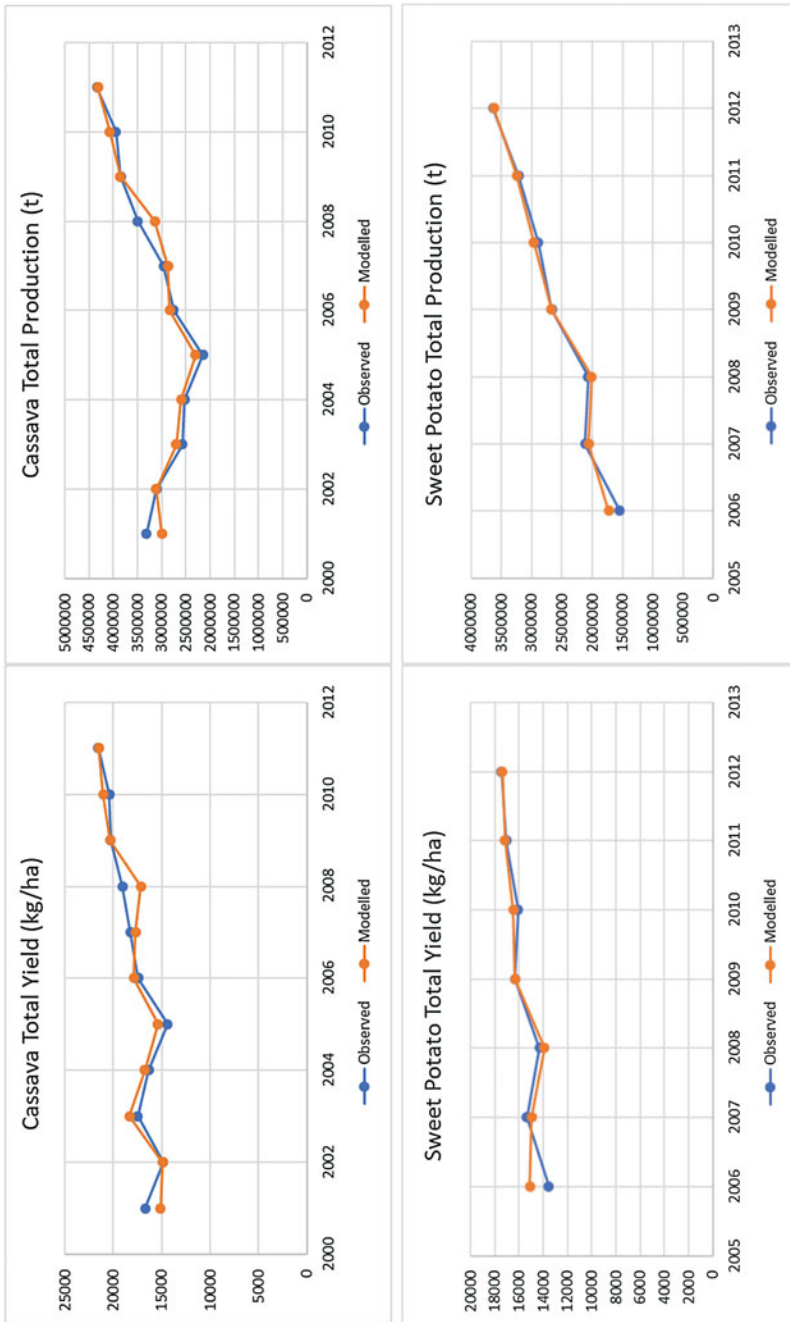
**Fig. 4** Log (ADD yield) versus log (modelled ADD yield) for maize, cassava, and sweet potato



**Fig. 5** Modelled and actual total yield and production for all three maize varieties

The models were finally assessed by their ability to explain the total yield and production across Malawi. The observed and modelled yield data were aggregated across all ADDs and plotted in Figs. 5 and 6. The spatially aggregated models provide accurate explanations of the observed values with average percentage differences from the actual annual values around 7% for the three maize varieties and less than 5% for cassava and sweet potato. The larger departures in these plots generally correspond with known accounting errors in the supporting yield data.

The fitted temperature index curves and the corresponding relative histogram of weekly temperatures observed over the fitted growing season for the 74 sites representing the eight ADDs across Malawi are plotted for local maize, hybrid maize, cassava, and sweet potato in Fig. 7. The plots show that the apparent temperature constraints on local maize and sweet potato are well matched to the observed weekly temperatures across Malawi, while the optimum temperatures of hybrid maize and cassava are somewhat larger than the mode of the observed weekly average temperatures. This suggests that projected future increases in temperature of



**Fig. 6** Modelled and actual total yield and production for cassava and sweet potato

around 2 °C would have minimal impact on local maize yield, perhaps slightly reduce sweet potato yield and moderately enhance yields of higher temperature adapted hybrid maize and cassava. Possible changes in soil moisture regimes also need to be taken into account to obtain a more complete estimate of the likely impact of projected future climate. Soil moisture status is particularly important in the grain filling stage of maize (Li et al. 2018).

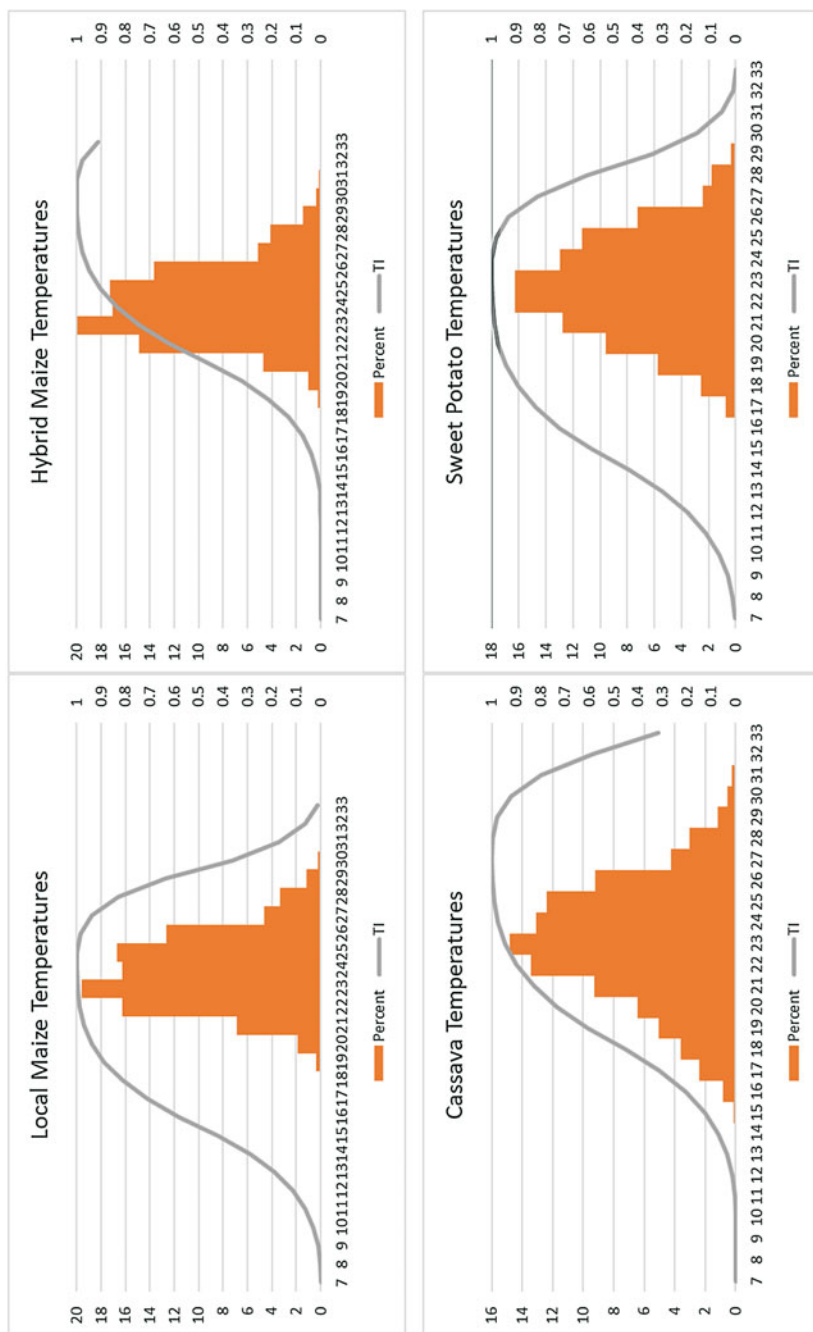
---

## Discussion

The fitted regressions on accumulated GI have provided reasonably accurate models of observed maize, cassava, and sweet potato yields for each ADD and are more accurate when aggregated to the national level. The model formulation is robust and able to fit well-determined trends on accumulated growth index, despite the uncertainty associated with the supporting data, including some imprecision in the location of actual crop growing areas and year-to-year variations in planting times and growing practice. Schlenker and Lobell (2010) have noted the particular difficulties in modelling cassava that this model has appeared to overcome.

The fitted growing seasons agree well with known practice. The fitted optimum temperatures also agree with generally accepted values for all five crops, with hybrid maize better adapted to higher temperatures than traditional local maize varieties. This close agreement with known values provides strong support for the adequacy of the fitted models in calibrating the climate dependencies of maize, cassava, and sweet potato yields. The formulation of the regression model has permitted an effective separation between site-specific effects (such as soil fertility and particular crop management practices) and climatic effects on relative plant growth. The site-specific effects are accounted for by a separate intercept for each ADD in the regression model, while the relative climatic effects appear to operate independently of different site conditions and can be effectively calibrated by a single factor across all ADDs. Allowing this factor to vary across the ADDs did not improve the fit of the model for any crop. The model formulation is similar to that employed by Lobell et al. (2011) but uses a specifically tuned nonlinear plant growth index instead of various growing season weather variables. The effectiveness of this modelling approach reflects the finding of Wang et al. (2017) that the form of the temperature response function is quite critical in the accuracy of crop simulation models. The functional form of the temperature indexes plotted in Fig. 7 is similar to the preferred functional forms described by Wang et al. (2017).

The single parameter for the climatic effects was an important factor in the robustness of the regression growth models. On the other hand, allowing a separate site-specific intercept for each ADD was an important factor in incorporating different conditions modifying yields across the different ADDs. The resulting robust statistical model could reliably detect data outliers, as confirmed by inspection of the supporting data for the contributing RDPs. The robustness of the spatial analyses of the supporting monthly climate data has also contributed to the robustness of the fitted growth models. The net result has been well-determined



**Fig. 7** Fitted temperature index curves (line) and observed monthly average temperatures (relative histogram) over the fitted growing season for local maize, hybrid maize, cassava, and sweet potato

coefficients calibrating the dependence of the three maize varieties and cassava and sweet potato yields on monthly climate via appropriately accumulated GI.

The models have simultaneously calibrated significant underlying increasing trends in yield over time that can be ascribed to improvements in plant breeding, crop management, and carbon dioxide fertilization. The fitted underlying trends of around 2% increase in yield per year for cassava and sweet potato may have been augmented by carbon dioxide fertilization. For such tubers there is around a 15% increase in tuber yield per 100 parts per million increase in atmospheric carbon dioxide concentration (Kimball 1983; Miglietta et al. 1998). In view of the prevailing rate of an increase in carbon dioxide concentration of two parts per million per year, this would give rise to an increase in tuber yield of around 0.3% per year over the analysis period. This is similar to the standard error of the fitted annual percentage increases in crop yield, making it difficult to discriminate from other increases in crop yield. It is not clear whether the fitted underlying percentage increases in crop yields will be maintained indefinitely. The impacts of improved production and reporting methods are likely to plateau in the future. However, ongoing improvements due to plant breeding and carbon dioxide fertilization are likely to continue, and the fitted trends of around 2% per year are remarkably consistent with the documented increase in world average cereal yields over the 50 years from 1961 to 2009 (Prohens 2011). It is unlikely that conventional crop breeding methods are able to maintain this rate of progress into the future, but Prohens (2011) argues that recent progress in molecular biology and genetic engineering offers great promise to further increase crop yields. Thus the fitted models should be able to be used, with appropriate qualifications, in assessing the impact of projected climate change.

---

## Conclusion

This study analyzed the impact of monthly climate on the observed yields of maize, cassava, and sweet potato across the eight ADD crop production regions of Malawi via a robust yield regression model that can be viewed as a hybrid approach between complex process-based models and statistical modelling using selected weather variables. It offers progress toward the eventual dissolution of the differences between these approaches as suggested by Lobell and Asseng (2017). A particular strength of the GROWEST model used here is its incorporation of a process-based temperature response function that could be readily tuned to maximize model performance. This reflects the finding of Wang et al. (2017) that appropriate parameterization of the temperature response function is critical to crop model performance. The tuning of the period of the effective growing season was similarly critical. An additional important contribution to the accuracy and robustness of the regressed GROWEST models is their effective separation of site-specific and climatic effects. This aspect is shared by the statistical modelling approach described by Lobell et al. (2011). Finally, the calibration of the model in terms of monthly, instead of daily, climate data offers robustness in delivering spatially distributed

climate data from limited point sources and in generating projected future climate data. Projecting daily precipitation data in particular is problematic with many approaches simply adjusting positive daily rainfall amounts but leaving daily rainfall occurrence structure unchanged. Such changes in daily precipitation structure can be subsumed within simple changes in monthly precipitation totals, although at the expense of losing some precision in the timing of precipitation within the month.

The main limitation of the modelling approach described here, and many others, is an assumption that management practice does not change significantly from year to year. This can be violated in periods of extreme drought or flooding when planting dates can be significantly delayed or disrupted. This assumption could also be violated in future scenarios when there could be a systematic shift in planting times in response to systematic changes in seasonal climate. Changes in planting density due to changes in intercropping practice are also possible. There is also an assumption that a fixed temperature response function applies over the entire growing season. The differing temperature optima over different stages of maize growth cited by Sánchez et al. (2014) suggest that the model could be usefully elaborated to reflect this, although at the expense of fitting additional model parameters. Despite these limitations, the GROWEST plant growth index model applied to spatially distributed monthly climate data has provided robust correlations between modelled and actual yields for all five crops examined. These correlations have yielded process-based parameter values that agree with known values, and the dependence on accumulated growth index has been fitted with enough precision for the models to be able to be used with reasonable confidence in projecting the impacts of climate change on future yields. The comparisons of the fitted temperature index curves with observed monthly average temperatures in Fig. 7 show that projected increases in temperature are likely to have minimal impact on local maize and sweet potato yield while yields of high temperature adapted hybrid maize and cassava are likely to be enhanced. Such projections need to be coordinated with projected changes in soil moisture levels.

---

## References

- Benesi IR (2005) Characterization of Malawian cassava germplasm for diversity, starch extraction and its native and modified properties. PhD thesis, Department of Plant Science, University of the Free State, Bloemfontein
- Cock JH (1984) Cassava. In: Goldsworthy PR, Fisher NM (eds) *The physiology of tropical field crops*. Wiley, Chichester, pp 529–550
- Denning G, Kabembe P, Sanchez P, Malik A, Flor R, Harawa R, Nkhoma P, Zamba C, Banda C, Magombo C, Keating M, Wangila J, Sachs J (2009) Input subsidies to improve smallholder maize productivity in Malawi: toward an African green revolution. *PLoS Biol* 17(1):e23
- Dongarra JJ, Moler CB, Bunch JR, Stewart GW (1979) *LINPACK user's guide*. SIAM Publications, Philadelphia
- Fitzpatrick EA, Nix HA (1970) The climatic factor in Australian grassland ecology. In: Moore RM (ed) *Australian grasslands*. ANU Press, Canberra
- Food and Agriculture Organization (FAO) (2005) *FAO/WFP Crop and Food Supply Assessment Mission to Malawi, June 2005*. <http://www.fao.org/3/J5509e/J5509e00.htm>



- Giertz A, Caballero J, Galperin D, Makoka D, Olson J, German G (2015) Malawi: agricultural sector risk assessment. World Bank Group report 99941-MW. World Bank, Washington, DC
- Heisey PW, Smale M (1995) Maize technology in Malawi: a green revolution in the making? CIMMYT research report no. 4. CIMMYT, Mexico
- Hutchinson MF, Xu T (2013) ANUSPLIN version 4.4 user guide. Fenner School of Environment and Society, The Australian National University. <https://fennerschool.anu.edu.au/research/products/anusplin>
- Hutchinson MF, Nix HA, McMahon JP McTaggart C (2002) GROWEST version 2.0. Centre for Resource and Environmental Studies. Australian National University, Canberra. <https://fennerschool.anu.edu.au/research/products/growest>
- Hutchinson MF, McIntyre S, Hobbs RJ, Stein JL, Garnett S, Kinloch J (2005) Integrating a global agro-climatic classification with bioregional boundaries. *Glob Ecol Biogeogr* 14:197–212
- Japan Association for International Collaboration of Agriculture and Forestry (JICA) (2008) The Maize in Zambia and Malawi. Accessed 10 Mar 2017. [http://www.apip-apec.com/ja/good-practices/files/The\\_Maize\\_in\\_Zambia\\_and\\_Malawi.pdf](http://www.apip-apec.com/ja/good-practices/files/The_Maize_in_Zambia_and_Malawi.pdf)
- Kawaye FP, Hutchinson MF (2018) Are increases in maize production in Malawi due to favourable climate or the farm input subsidy program? In: Alves F, Filho WL, Azeiteiro U (eds) Theory and practice of climate adaptation. Springer, Cham, pp 375–390
- Kimball BA (1983) Carbon dioxide and agricultural yield: an assemblage and analysis of 430 prior observations. *Agron J* 75:779–788
- Li Y, Tao H, Zhang B, Huang S, Wang P (2018) Timing of water deficit limits maize kernel setting in association with changes in the source-flow-sink relationship. *Front Plant Sci* 9:1326
- Lobell DB, Asseng S (2017) Comparing estimates of climate change impacts from process-based and statistical crop models. *Environ Res Lett* 12:015001
- Lobell DB, Bänziger M, Magorokosho C, Vivek B (2011) Nonlinear heat effects on African maize as evidenced by historical yield trials. *Nat Clim Chang* 1:42–45
- Mathias L, Kabambe VH (2015) Potential to increase cassava yields through cattle manure and fertilizer application: results from Bunda College, Central Malawi. *African J Plant Sci* 9(5):228–234
- Mathieu-Colas L, Bahers G, Makina LM (2009) CROP MANAGEMENT: roots and tubers trainer's guideline. Fiche AGRO – Cultures, Inter Aide Agro-Phalombe, Malawi
- Miglietta F, Magliulo V, Bindi M, Cerio L, Vaccari FP, Loduca V, Peressotti A (1998) Free air CO<sub>2</sub> enrichment of potato (*Solanum tuberosum* L.): development, growth and yield. *Glob Chang Biol* 4:163–172
- Mkumbira J (2002) Cassava development for small scale farmers: approaches to breeding in Malawi. Doctoral thesis. Swedish University of Agricultural Sciences, Uppsala, Sweden. Acta Universitatis Agriculturae Sueciae. Agraria 365. Tryck:SLU Service/Repro, Uppsala
- Nassar NMA (2004) Cassava: some ecological and physiological aspects related to plant breeding. *Gene Conserv* 3(13):229–245
- Ngwira LDM, Sibale EM (1986) Maize research and production in Malawi. In: Gelaw B (ed) To feed ourselves: proceedings of the first eastern, central, and southern African regional maize workshop. Mexico, CIMMYT
- Nix HA (1981) Simplified simulation models based on specified minimum data sets: the CROPEVAL concept. In: Berg A (ed) Application of remote sensing to agricultural production forecasting. Commission of the European Communities, Rotterdam, pp 151–169
- Pauw P, Thurlow J, van Seventer D (2010) Droughts and floods in Malawi. IFPRI discussion paper 00962. International Food Policy Research Institute, Washington, DC
- Prohens J (2011) Plant breeding: a success story to be continued thanks to the advances in genomics. *Front Plant Sci* 2:Article 51
- Ramirez P (1992) Cultivation harvesting and storage of sweet potato products. In: Machin D, Nyvold S (eds) Roots, tubers, plantains and bananas in animal feeding. Proceedings of the FAO Expert Consultation held in CIAT, Cali, Colombia 21–25 January 1991; FAO animal production and health paper – 95
- Ray DK, Gerber JS, MacDonald GK, West PC (2015) Climate variation explains a third of global crop yield variability. *Nat Commun* 6:5989

- Ray DK et al (2019) Climate change has likely already affected global food production. *PLoS One* 14(5):e0217148
- Sánchez B, Rasmussen A, Porter JR (2014) Temperatures and the growth and development of maize and rice: a review. *Glob Chang Biol* 20:408–417
- Schlenker W, Lobell DB (2010) Robust negative impacts of climate change on African agriculture. *Environ Res Lett* 5(1):014010
- Wang E et al (2017) The uncertainty of crop yield projections is reduced by improved temperature response functions. *Nat Plants* 3:17102

**Open Access** This chapter is licensed under the terms of the Creative Commons Attribution 4.0 International License (<http://creativecommons.org/licenses/by/4.0/>), which permits use, sharing, adaptation, distribution and reproduction in any medium or format, as long as you give appropriate credit to the original author(s) and the source, provide a link to the Creative Commons license and indicate if changes were made.

The images or other third party material in this chapter are included in the chapter's Creative Commons license, unless indicated otherwise in a credit line to the material. If material is not included in the chapter's Creative Commons license and your intended use is not permitted by statutory regulation or exceeds the permitted use, you will need to obtain permission directly from the copyright holder.





# Addressing Climate Change Vulnerability Through Small Livestock Rearing in Matobo, Zimbabwe

# 34

Keith Phiri, Sibonokuhle Ndlovu, Moreblessings Mpofu,  
Philani Moyo, and Henri-Count Evans

## Contents

Introduction .....	640
The Impact of Climate Change in Zimbabwe .....	641
Climate Change and Vulnerability .....	641
Adaptation Strategies in Zimbabwe .....	643
Study Site and Context .....	644
Materials and Methods .....	644
Results and Discussions .....	645
Small Livestock and Climate Change Nexus in Matobo .....	645
Constraints to Small Livestock Rearing .....	650
Institutional Mandate Response on Small Livestock Production .....	653
Conclusions .....	655
Recommendations .....	655
References .....	656

This chapter was previously published non-open access with exclusive rights reserved by the Publisher. It has been changed retrospectively to open access under a CC BY 4.0 license and the copyright holder is “The Author(s)”. For further details, please see the license information at the end of the chapter.

K. Phiri (✉) · P. Moyo

Fort Hare Institute of Social and Economic Research (FHISER), University of Fort Hare, East London, South Africa

e-mail: [kephirh@gmail.com](mailto:kephirh@gmail.com); [pmoyo@ufh.ac.za](mailto:pmoyo@ufh.ac.za)

S. Ndlovu · M. Mpofu

Department of Development Studies, Faculty of Humanities and Social Sciences, Lupane State University, Bulawayo, Zimbabwe

e-mail: [boomagwala@gmail.com](mailto:boomagwala@gmail.com); [moreblessingsncube@gmail.com](mailto:moreblessingsncube@gmail.com)

H.-C. Evans

School of Applied Human Sciences, Centre for Communication, Media and Society, University of Kwazulu-Natal, Durban, South Africa

e-mail: [henricount@gmail.com](mailto:henricount@gmail.com)

© The Author(s) 2021

W. Leal Filho et al. (eds.), *African Handbook of Climate Change Adaptation*,  
[https://doi.org/10.1007/978-3-030-45106-6\\_121](https://doi.org/10.1007/978-3-030-45106-6_121)

639

---

**Abstract**

Livestock rearing is a popular climate change adaptation strategy among farmers in Matobo District, Zimbabwe. In this chapter we reveal how farmers in Matobo District have benefited immensely from rearing small livestock in response to climate change. Although the descriptor “small livestock” generically refers to different types of livestock, in this chapter we limit it to goat and sheep rearing. The purpose of the chapter is (1) to discuss the efficacy of small livestock rearing as a response to climate change and (2) to use smallholder farmer’s narratives to evaluate the success of government interventions in enhancing small livestock production. Utilizing an inductive approach, data was gathered through five (5) key informants, five (5) focus group discussions, and 50 in-depth semi-structured interviews. Our study reveals that small livestock are suitable and adaptable to climate change impacts in Matobo. We recommend that government and its development partners prioritize and avail funds for the increased uptake of small livestock rearing among smallholder farmers in Matobo District and beyond.

---

**Keywords**

Adaptation · Climate change · Small livestock · Smallholder farmers · Matobo · Zimbabwe

---

**Introduction**

Small-scale communal livestock rearing plays an essential role in sustaining livelihoods in developing countries. Livestock is central to food security, nutrition, organic fertilizer (manure) production, non-mechanized ploughing, and income generation initiatives (Nandhini and Suganthi 2018). However, as climate change impacts are increasingly being felt across the world, poor countries are most affected owing to poor adaptive capacity and budgetary constraints compared to more developed countries in the global North (Chaudhury 2017). Developing countries’ vulnerability is worsened by their strong dependence on rain-fed agriculture and free range pasture-fed livestock, which are susceptible to the negative effects of changing climate (Dube and Phiri 2013; Brazier 2015; Apraku et al. 2018a). Livestock plays an essential role in sustaining the fragile economies of most developing countries, with more than half of the rural population being sustained by livestock production (Kaasschieter et al. 1992; Assan and Kumar 2009; Assan 2014). Kaasschieter et al. (1992) note that “the largest share of the world’s livestock population is found in developing countries: 61% cattle, 43% sheep, 79% goats, and 57% pigs.” Of the stated livestock, “the production of small livestock like goats and pigs strengthens the capacity of communities to adapt to climate change” (Ndlovu 2010; Girus et al. 2008). Small livestock have higher chances of surviving under climate change conditions like increased droughts compared to bigger livestock since they require smaller grazing land and less amount of water and are less affected by the depletion

of pastures. Assan (2014) argues that livelihoods sustainability in rural areas can be achieved through livestock production in the face of rapidly changing climate that weakens crop production especially in arid climates like Zimbabwe. It is against this backdrop that the International Union for Conservation of Nature and Natural Resources (2010) observes that rural livelihood systems in Southern Africa are converting from mixed crop-livestock to pure rangeland systems. Although livestock production in arid agroecological regions of Zimbabwe is yet to be endorsed as an agricultural policy, there is increased support for the uptake of livestock rearing from the government's Livestock Production Department (LPD).

Given the foregoing, the research thus examined the efficacy of small livestock production as a climate change adaptation strategy in Matobo District compared to the much traditionally desired cattle rearing. This switch is being pioneered by Khulasizwe which is a nongovernmental organization (NGO) operating in Matobo wards 3, 4, 10, and 19 with the aim of enhancing household livelihood security. Khulasizwe has thus far distributed goats to 380 households in the targeted wards (World Vision 2015). It is crucial to investigate community narratives (and experiences) about the effectiveness of this technical adaptation strategy. The study sought to answer the following research questions: What benefits (if any) are Matobo community members deriving from the switch to small livestock production? What has been the uptake of this strategy in the broader Matobo community over and above the project beneficiaries?

---

## The Impact of Climate Change in Zimbabwe

There is consensus that climate change is causing more socioeconomic, health, and environmental harm in developing countries (Van Aelst and Holvoet 2016; Kahsay and Hansen 2016; Apraku et al. 2018a, b). The harm is exacerbated by the fact that most of the population these countries is heavily reliant on the natural environment for survival, both of which are highly susceptible to climatic changes. Consequently, climate change is negatively impacting the livelihoods of the poor as well as deepening poverty in many developing countries (Africa Partnership Forum 2008; Nyong 2009; Phiri et al. 2014, 2019). In Zimbabwe, the adverse impacts of climate change are particularly felt in the rural areas where the majority of the population (67%) lives and mostly depend on agriculture-based livelihoods (ZIMSTAT 2013). Within the context of the unfolding adverse effects of climate change, vulnerable communities are adapting to these conditions by "rearing small drought resistant livestock such as goats" (Zimbabwe's National Climate Change Response Strategy 2014).

## Climate Change and Vulnerability

Climate-induced variability increases the vulnerability of rural livelihoods and reduces the ability of households to deal with risks, shocks, and stresses (Prowse and Scott 2008). Dulal et al. (2010) and Ndlovu et al. (2019) concur with the above

argument that, since households typically have limited assets, they are at increased risk (exposure) and their ability to cope is restricted. Cutter et al. (2000) and Dube et al. (2017) point out that livelihood vulnerability to climate change can be usefully understood as an outcome of biophysical and social factors. Firstly, biophysical climate change vulnerability refers to the level of exposure communities' physical impacts of sea level rise, increase in sea surface, or atmospheric temperatures. Secondly, social vulnerability is explained as partially the product of those factors that shape the susceptibility of communities to harm and those that govern their ability to respond. It also includes "place inequalities" – those characteristics of communities and the built environment, such as the level of urbanization, growth rates, and economic vitality – that contribute to the social vulnerability of particular places (Cutter et al. 2000; Shah et al. 2013).

Moss et al. (2001) add a third dimension as an external assistance, which is defined as "the degree to which a region may be assisted in its attempts to adapt to change through its allies and trading partners, diasporic communities in other regions, and international arrangements to provide aid." In contrast to the United Nations (2004), this conceptualization of vulnerability includes factors outside the vulnerable system, such as characteristics of the stressor and the expected level of external assistance.

Four dimensions have been identified as defining a vulnerable situation within the literature. The first dimension consists of human-environment system, population group, economic sector, geographical region, or natural system (Downing and Patwardhan 2004). They note that other researches limit vulnerability to social systems coupled with human-environment systems (Turner et al. 2003) whereas others apply it to any system that is potentially threatened by a hazard (Mcbean 2012). The second dimension is the attribute of concern. Examples of attributes of concern include human lives and health; the existence, income, and cultural identity of a community; and biodiversity, carbon sequestration potential, and timber productivity of a forest ecosystem (Downing and Patwardhan 2004).

The third dimension is the hazard. United Nations (2004) defines a hazard broadly as "a potentially damaging physical event, phenomenon or human activity that may cause the loss of life or injury, property damage, social and economic disruption or environmental degradation." Hence, a hazard is understood as some influence that may adversely affect a valued attribute of a system. A hazard is generally but not always external to the system under consideration. For instance, a community may also be threatened by hazardous business activities or by unsustainable land management practices within this community. Hazards are often distinguished into discrete hazards, denoted as perturbations, and continuous hazards, denoted as stress or stressor (Turner et al. 2003).

Finally, the fourth dimension is the temporal reference which denotes the point in time or time period of interest. Specifying a temporal reference is particularly important when the risk to a system is expected to change significantly during the time horizon of a vulnerability assessment, such as for long-term assessments of anthropogenic climate change (Downing and Patwardhan 2004).

## Adaptation Strategies in Zimbabwe

Adaptation strategies need to be understood using the concept of “adaptive capacity.” Adaptive capacity has been defined as the ability or potential of a system to respond successfully to climate variability and change, and this includes adjustments in both behavior and in resources and technologies (IPCC 2007). Other scholars define it as the potential of a system to adjust itself to change (Watts and Bohle 1993; Smit et al. 2000; Turner et al. 2003; Fussel and Klein 2006). According to Armitage and Plummer (2010: 6), adaptive capacity is:

generally referred to as the capability of a social-ecological system to be robust to disturbance, and to adapt to actual or anticipated changes (whether exogenous or endogenous). From a social systems vantage point adaptive capacity is determined by the suite of resources (technical, financial, social, institutional, political) held, and the social processes and structures through which they are mediated (i.e. governance).

From the perspective of the social sciences, adaptive capacity does not just explain how people cope with change but reflects an ability to learn, experiment, and foster innovative solutions in complex social-ecological circumstances (Cutter et al. 2003; Armitage and Plummer 2010). Therefore, the capacity of households and communities to adapt to climate change cannot be under emphasized. In response to the negative climate change impacts, smallholder farmers are adopting a variety of adaptation strategies in Zimbabwe. There is consensus that rural communities in Zimbabwe have not been mere passive victims of climate change but have been action oriented in adapting to climate variability (Gukurume 2013; Dube et al. 2018; Kahsay and Hansen 2016). Crop diversification, mixed crop livestock systems, changing planting times, and conservation farming are some of the strategies that have been adopted by communal farmers in Zimbabwe (Munhande et al. 2013; Musarurwa and Lunga 2012; Makuvaro et al. 2014).

In addition, Mano and Nhemachena (2006) argue that climate change has severely reduced chances of rain-fed crop farming in arid regions of the country such that they suggest livestock production as the most suitable strategy that can drive communities out of food insecurity and poverty. Gukurume (2013) notes that livestock production was on the increase in Bikita and other places in dry regions, indicating that farmers are replacing crops with livestock production in order to promote livelihood sustainability. The government through its departments is also encouraging farmers in areas prone to increased dry spells to invest more on livestock, because they can withstand the harsh weather conditions induced by climate change. Small stock like goats, sheep, and indigenous poultry are becoming dominant as people try to cope with drought in areas continuously receiving little rainfall (Gukurume 2013). However, Munhande et al. (2013) observed that climate change hugely contributes to extreme temperatures, severe water scarcity, and reduced fodder for livestock, especially large stock leading to poor animal production.

Water harvesting techniques (WHTs) are another climate change adaptation strategy available to communities. Rain-water harvesting (RWH) technologies are a range of techniques used for collecting, storing, and conserving rainfall and surface runoff in arid and semiarid regions (Mutekwa and Kusangaya 2006). WHTs are more amenable to “small livestock” because they consume less water compared to “large livestock” like cattle.

A very traditional and significant adaptation strategy that had been practiced particularly for rural communities is livestock herding. According to Leichenko and O’Brien (2002) livestock herding, including nomadic pastoralism, remains one of the indigenous strategies best adapted to frequent droughts in dry land areas such as in Namibia and Botswana. Seasonal movement of livestock, splitting up of herds, changing herd composition, and distributing livestock among relatives and friends in different areas minimize risk from droughts, floods, or diseases. Appropriation of the wetter areas and water sources for cultivation and fencing inhibits these crucial strategies, however.

---

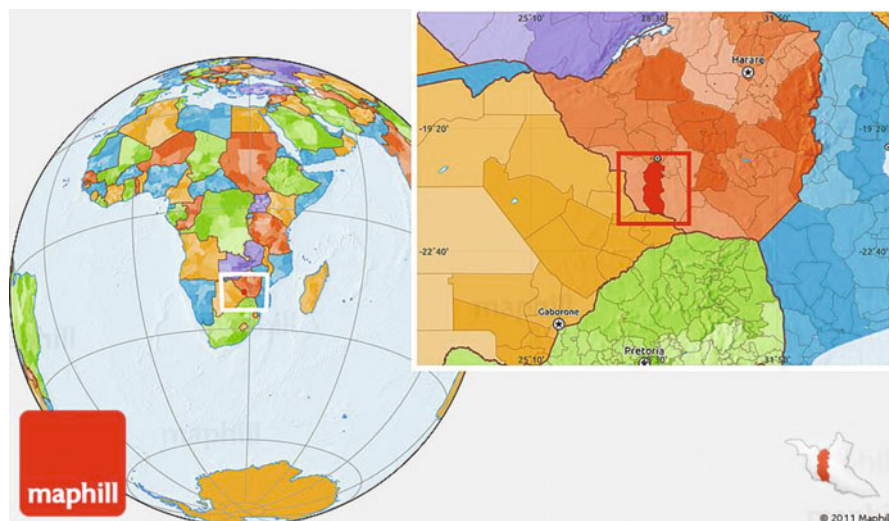
## Study Site and Context

The study was conducted in Matobo Rural District of Zimbabwe which lies in ecological regions IV and V characterized by low and erratic rainfall (450–650 mm/year) with very high temperatures. Of the 27 wards in Matobo District, the study wards were (Gwezha, ward 3; Marko, ward 4; Makhasa, ward 10; and Zamanyoni, ward 19). Climate change has worsened the already extreme weather patterns in the district. Drought is an example of this phenomenon that has affected Matobo District in a negative way. Data emerging from the interviewed farmers shows that the prolonged droughts have dried up natural water points such as streams, rivers, and swampy areas (Fig. 1). Consequently, their pastures and grazing lands for their livestock have been depleted. **The study was conducted from March to September 2017.**

## Materials and Methods

The research employed a qualitative methodology which was more suitable for capturing community narratives and experiences about the appropriateness and effectiveness of small livestock production within the context of a changing climate in Zimbabwe. As highlighted by Turner et al. (2003), the primary strength of the qualitative approach to cultural assessment is the ability to probe for underlying values, beliefs, and assumptions. Data collection tools employed included the use of in-depth semi-structured interviews (50 households), 5 focus group discussions, and 5 key informants conducted using purposive sampling in 4 selected wards of Matobo District of Zimbabwe. The limitations of the study are that findings on how small-holder farmers adapt to climate change through small livestock in Matobo District cannot be generalized to other districts in Zimbabwe and beyond. Success of these





**Fig. 1** Map of Zimbabwe (showing Matobo District)

technical climate change adaptation strategies is location specific. However, important lessons can be drawn from the narratives of the smallholder farmers in semiarid districts and go on to influence policy.

---

## Results and Discussions

### Small Livestock and Climate Change Nexus in Matobo

Small livestock, namely, sheep and goats, are relatively more adaptive to negative changing climatic conditions compared to cattle. Goats are both grazers and browsers, while cattle are limited to the latter (Girum et al. 2008). The chances of survival for small livestock are higher compared to cattle in the context of a changing climate. Moreover, on the basis of their size, the goats consume less from the pastures in a specified area in comparison to cattle that demand more feed due to their sheer size. The amount of water drunk by goats and sheep is far less than that of cattle. Small livestock have a comparative risk aversion advantage in that respect. The suitability and appropriateness of small livestock in a climate change environment are premised on the aforementioned characteristics.

### Goat Production

In the context of the study area, a key informant justified the rearing of small livestock when he explained that:

Even in times of drought, small stock (goats) herd will multiply because they reproduce at two to three times the rate of cattle. A goat may produce one to four kids in a year as opposed to one birth every one and a half years to two years for cattle. The farmers in Matobo can attest to that. It is a known fact in Matobo that goatherders fare well in comparison to cattle herders in general. (Key Informant 4, Khulasizwe Trust)

Furthermore, another important statement was made in respect to small livestock rearing in Matobo. Key informants 1 and 3 indicated that:

Small livestock are particularly important and useful during and after a drought or disaster period. It is easy for farmers who are keeping goats for instance, to sell the goats for cash, give goats as a gift, or slaughter for food or traditional ceremony. This is because the amount of money and food generated by a single goat is optimal for day to day transactions. (Key Informant 3, AGRITEX)

The most popular small livestock that the farmers keep are goats. Pigs are shunned because of religious reasons...and generally because they need to be fed a lot which is highly cost ineffective and therefore not sustainable particularly for rural communities who are already struggling enough to meet household needs. The sheep herd is relatively small as well because there is too much work involved in rearing them. Sheep need special care. (Key informant 1, World Vision)

Similarly, the views raised by interviewed smallholder farmers were in tandem with what was also raised by the key informants.

Three of the respondents from different wards commented that:

Small livestock are a good insurance against crop failure. When our harvest is low— we have an easy alternative that is of slaughtering a goat. We value our goats because they give us meat, milk and manure for our gardens. We also use the goat skin as a carpet and sell to obtain cash for petty trading. (Household Respondent 26, Marko)

Goats are doing very well for me despite the heavy rainfalls and hot temperatures this year. I started with 5 goats but I now have 27 goats in less than 3 years. They multiply faster compared to cattle provided that they are dosed regularly. I love rearing goats because they do not demand stock feed like cattle. Moreover, they can even feed on groundnuts and round nuts leaves. Goats are basically easy to maintain in a climate change environment. (Household Respondent 33, Makhasa)

I do not have a lot of goats myself but I have friends who are rearing a lot of them. I know of one farmer who possesses over 50 goats. From my observation, these small livestock don't collapse and die due to high temperatures and drought. They survive unlike cattle. They feed close to the homestead and can easily be watered by the owners. In times of crisis, goats can be exchanged for money or grains for food or feeding the community during a funeral wake. (Household Respondent 21, Zamanyoni)

A key informant from AGRITEX emphasized that even those who do not have cattle perceive goats and sheep as a symbol of wealth. One of the commentators in a focus group discussion indicated that there is a lot of contempt in society for one that does not have any kind of livestock and few villagers are likely to attend his funeral. For most farmers who do not have cattle, goats are a good source of relish during funerals when villagers gather in the bereaved homestead. The key informant added that small livestock are also kept for security reasons. They are likely to cushion the farmers during times of drought when the harvest from their fields is very low. They

can be eaten or exchanged for grain or sold for cash to buy other household consumables during hard times. This point was also raised by interviewed smallholder farmers earlier in the discussion. It is clear from the above comments that small livestock, specifically goats, play a pivotal role as a livelihood strategy in Matobo District.

The smallholder farmers are aware of the competitive advantage of rearing goats over cattle in their specific area of habitation. Firstly, as a source of food, goats are easily slaughtered to obtain meat to meet food needs at the household level or feeding community members in funeral wakes and traditional and cultural rituals like weddings. Goat milk is also a preferred source of food in selected households specifically for children. Secondly, goats are acknowledged to be easy to keep and maintain in a harsh climatic environment compared to cattle because they consume less food and are more drought resistant compared to cattle. Thirdly, goats are utilized by farmers as a medium of exchange to pay school fees, hospital bills, and other urgent needs of the households. Interviewed farmers unanimously indicated that it is easier to sell goats than cattle.

It emerged from the sampled respondents that the Matabele goat is common in Matobo District because it is an indigenous breed that has been kept there since time immemorial. However, the key informant from AGRITEX indicated other breeds like the Boer goat and Kalahari red are common in areas like Gwanda and Beitbridge. This is so on account of farmers' cross-breeding them due to the proximity and accessibility of South Africa at the Limpopo province. The Mashona goat is mainly confined to Mashonaland province of Zimbabwe (Table 1).

Experts in the field of small livestock rearing concur that goats are an effective strategy for adapting to climate change in the study area. Their views go beyond the perception of interviewed farmers who are yet to fully appreciate this knowledge beyond merely keeping goats as a tradition. The key informant from Khulasizwe justified the rearing of small livestock like goats over cattle for a number of reasons. He noted that:

Goats can withstand the harsh climatic changes and are not prone to collapsing like cattle. They feed on vegetation not used by other domestic species of animals since they are browsers. Goats do not easily succumb to diseases. Farmers living in marginal agricultural areas can keep them. Moreover, they are easy to handle and can be looked after by children and women. (Key Informant 4, Khulasizwe)

Another key informant from the Department of Livestock Production and Development gave a lengthy response in showing the viability and effectiveness of goats' production over cattle production. He narrated that:

Goats multiply very easily and flocks expand in a relatively short time forming a major part of the family asset base in a harsh changing climate. Goats have an economic advantage over large ruminants because they are cheap to buy hence they provide an opportunity for vulnerable people to own them. They can quickly and easily be sold off for cash to meet family emergency needs like health costs, educational needs, in times of death and therefore are an easily disposable asset during times of poverty and calamities. With goat rearing, there are none or few social, religious and cultural taboos associated with keeping them in Zimbabwe. (Key Informant 5, DLPD)

**Table 1** Common goat breeds in Zimbabwe

Goat breed	Characteristics
Matabele goat	This breed is found mostly in the southern part of the country. It is large framed animal
	Mature weight can reach up to 50 kg plus for males and between 35 and 40 kg females
	It is a dual-purpose breed (meat and milk production)
	Has multiple colors ranging from white through brown, mixed to black
	Can give birth to singles, twins, and triplets
	Adapted to local conditions
	Gestation period is between 145 and 154 days
Can be mated for the first time at 18 months of age	
Mashona goat	It is small-framed breed
	It is highly prolific
	Tolerant to local diseases
	Found in the northern parts of the country
	Mature weight is 30 and 35 kg for females and males, respectively
	Color ranges from white, mixed to black
	Edible and saleable proportion after dressing is 48% of the live body weight (equivalent to 12–14.5 kg)
	Sexual maturity is 7 months but a relatively slow growth rate. Goats are mainly kept for meat
They have good potential for selection to increase productivity	
Boer goat	It originates from South Africa and is well adapted to the southern parts of the country
	This is a large framed breed, with white body and a brown neck and head
	Adult female can grow up to 60–70 kg and males up to 70–90 kg
	It is mainly for meat production
	Very stocky body, well-muscled, strong bones
	Ears are pendulous and horns are prominent
	Very prolific breed, kidding rate of 1, 5 (three times in 2 years)
	50% twins and 7% triplets
Valuable for meat, milk, and skin but has been promoted for its meat potential	
Saanen goat	Originated from Switzerland or France
	Large size, white color with black spots on the nose, ears, and udder
	Hair coat is short; ears are erect and forward and upward
	Face is straight, slightly dished
	Good body conformation

Source: Khulasizwe File Report (2018)

From a technical point of view, it was evident that small livestock especially goats are a viable adaptation strategy to climate change effects. Key issues raised in support of their breeding were by virtue of their size in comparison to cattle; the risk of loss is small. It was suggested that for every cow one has an equivalent of six goats. The land size for communal farmers is small, and therefore keeping goats rather than cattle enables them to reach economies of scale. The eating habits of

goats (grazers and browsers) mean they have a more varied diet and can survive in drier areas. They basically can survive in any terrain that can either be hilly or flat terrain. In addition, it was revealed by the key informants that where water is scarce, goats can survive without drinking water for 2 days. However, the conscious decision to rear small livestock for the purpose of responding to climate change is yet to be understood by the smallholder farmers depending on efforts by government and its partners to spread that knowledge and the willingness of the respondents to accept that reality.

### **Sheep Production**

Data gathered from the study area also revealed that 20% of the interviewed farmers rear sheep. However, despite their resilience to the impact of climate change, they are not produced en masse in Matobo District in comparison to goats and chickens. The reasons given by two interviewed households were that:

Sheep easily get lost because they can hardly re-track their way back if they feed a distance away from home. Due to that fact, sheep demand more labour than other livestock since they require close attendance almost all the time. (Household Respondent 24, Gwezha)

Keeping sheep is hard work and not ideal for these reasons. When thieves and predatory animals like jackals and hyenas pounce in the night, they do not make any noise. We are not alerted that there is impending danger the same way goats make a loud noise when disturbed. As a result, we have lost quite a number of sheep due to this problem. We are therefore, reluctant to rear them in our village. (Household Respondent 40, Zamanyoni)

On a different note, the interviewed farmers who are rearing sheep had other reasons that they gave for doing so besides their adaptability to climate change. The reasons are purely religious beliefs. The following views confirm that:

We keep sheep for the purpose of enterprising especially with white garment churches known as apostolic sects. They believe that the tail of the sheep on which they extract fat brings good luck. Whether that is true or not is not an issue for me. As long as I can make money out of them, I do not care. I am keeping 53 sheep. It's a big market for me and my household. (Household Respondent 3, Marko)

Most of those households that keep sheep are superstitious. They believe that if you rear sheep your homestead can never be struck by lightning. Climate change has also come about with lightning and terrifying thunder. As a protection measure, sheep are kept to ward off that risk. For sure, I know no household in the village that has been struck by lightning that kept sheep. (Household Respondent 19, Makhasa)

The key informants acknowledged that specific farmers in the district held such indigenous knowledge beliefs about sheep being said to prevent lightning and the supernatural powers they possess to ward off bad luck and bring good fortune. Their belief system primarily informs their choice of rearing sheep. The production of sheep for the purpose of adapting to climate change is secondary under those circumstances. In this instance, small livestock keeping is a tradition passed on through generations and is not intended as a direct response to climate change. All household respondents kept one form of small livestock or another. However, it should be noted that it is not attributed to responding to climate change per se but a

continuation of what has always been the norm in the district since time immemorial. The findings also show that because of the traditional inclination to goat rearing, farmers' knowledge on which types of goats are reared is lacking and immaterial. Farmers in Matobo are not really concerned about the types of breeds that they are rearing; they keep whatever breed that they can access or obtain. This lack of knowledge on breed types has however an implication on the effectiveness of small livestock as adaptation options to climate change. Sustained and successful adaptation strategies demand a level of knowledge and understanding about livestock breeds and their resilience to the adverse effects of climate change.

### **Feminization of Small Livestock Rearing in Matobo**

In Matobo, rearing of sheep and goats is mostly relegated to women. While men do keep small livestock in Matobo, it is understood that it is a feminine exercise. On that basis, men play a peripheral role in small livestock rearing and would prefer to focus on owning cattle. It is an unwritten law that women (especially those that are married) may not slaughter a beast under any circumstances without prior approval of their husbands. This points to a strong patriarchal culture that is predominant even in climate change adaptation strategies.

---

### **Constraints to Small Livestock Rearing**

Despite the fact that small livestock have a comparative advantage in adapting to climate change over cattle in the study area, the production is beset by subtle challenges that threaten its viability and effectiveness. For instance, the key informant from the DLPD commented that:

While goats' production is a good option for adapting to climate change in Matobo, they have their own share of problems. Goats can be destructive animals only if overgrazing in areas occurs, resulting in reduced or loss of tree regeneration. Moreover, goats have a tendency to stray and eat neighbours' crops. Therefore, goats should be herded properly. (Key Informant 5, DLPD)

The respondents in the study area were more concerned about the security of their livestock more than anything else. Thieves and predatory animals like hyenas and jackals threatened the viability of their small livestock. The following comments were made during a focus group discussion:

Jackals are a big problem in our village. Four jackals can chase one goat till they catch and kill it. Sometimes we see the jackals during the day. They are so daring these days. I recently lost 3 of my goats as a result of jackals. Unless, one devises a mechanism of herding them throughout the day— they will get eaten. I am actually better off— my neighbor lost 12 goats within a month. Jackals are really a menace. (Marko Focus Group Discussion, Participant 2)

Stock theft is a common occurrence in our village. The incidences are rampant probably because of hunger perpetuated by what you call climate change. Crop yields are no longer enough to feed the communities throughout the year. Sadly, some people in the village resort

to stealing chickens and goats to make ends meet. I own 65 goats. I lost 13 just last year to thieves. It's not acceptable. (Zamanyoni Focus Group Discussion, Participant 9)

Hyenas have cost me a great deal of my goats. They target the kid goats especially. Twenty-one of my goats got eaten by hyenas. We cannot even hunt them down because it is a criminal offence. The government is not doing anything to protect our goats from the menacing hyenas. (Gwezha Focus Group Discussion, Participant 5)

The interviewed farmers also narrated that thieves are so daring in certain instances. It was noted that thieves can even drive goats in broad daylight when they have observed that they are not herded by any one. The villagers suspect that they sell them in nearby urban areas like Bulawayo where there is a ready meat market. The key informants from World Vision, Khulasizwe, AGRITEX, and DLPD confirmed the issues raised by farmers on losses of their small livestock as a result of thieves and predatory animals. As a result, some livestock security strategies have been developed by community members. Plate 1 a, b is a new idea of goat and sheep kraals in Matobo District.



**Plate 1** (a and b) Goat and sheep kraals

The key informant from DLPD commented that they are encouraging the construction of these kraals because:

...they are constructed in an elevated manner to prevent hyenas and jackals from killing the sheep and goats. They also serve the purpose of protecting the sheep from harsh weather conditions like intense heat and heavy rainfall. Traditional kraals which are constructed at ground level were not as secure as this new model. Thus, farmers are able to protect their livestock from being attacked and also prevent diseases caused by exposure from the heat and intense precipitation. (Key Informant 5, DLPD)

The Department of Livestock Production and Development in conjunction with local NGOs has been instrumental in encouraging farmers in the study area to construct these new kraals to preserve and protect their small livestock.

Another very important challenge that negatively affects the interviewed farmers is the diseases that reduce the number of their small livestock. Diseases like liver fluke, round worms, aching eyes, lump skin, pulp kidney, and heart water have affected livestock in the study area in varying degrees. In the face of these challenges, interviewed farmers seem to be helpless. There is little that they have done to treat their animals despite the few trainings received from the veterinary department. Farmers do not seem to understand the kind of diseases that are affecting their livestock. When asked about what kind of diseases affect their livestock, the farmers usually respond by describing what happened; they fail to state the disease that has led to the mortality of their livestock either in vernacular or in English. They just refer to them as *igazi (blood)*, or any other terms that describe the symptoms not the disease. Three interviewed farmers commented that:

Out of 35 goats, I lost all 16 in a single year through a strange disease, but could do nothing about it. I just watched helplessly. Some of us don't believe that drinking stagnant water can affect our livestock. Our goats used to drink from the same rivers and dams which are said to be causing their death. We don't understand why. We don't have money to buy the chemicals to treat our animals. (Household Respondent 41, Makhasa)

We have received training on how to identify diseases and cure them from the Veterinary Department. The medication for dosing and injecting our goats are both expensive and not accessible in Maphisa. Bulawayo is too far where we are referred to. We end up resorting to traditional medicines to cure our livestock. The Veterinary Department discourages us from doing so. But what other options do we have? (Household Respondent 27, Zamanyoni)

Goats and sheep are affected by liver fluke and bowels due to drinking stagnant water. There are no signs or symptoms for these two diseases, one just discovers after the death of the animal. I have lost three goats because of liver fluke. (Household Respondent 15, Gwezha)

Over and above the lack of disease knowledge, the expensive medication from the veterinary department is also responsible for the high mortality rate of goats and sheep. The farmers are too poor to purchase the recommended medication to cure their animals. Consequently, they suffer heavy losses due to diseases like liver fluke, round worms, aching eyes, lump skin, pulp kidney, and heart water. Farmers were clueless on how some of those diseases could be dealt with. Moreover, there is some resistance on dipping goats which solves the tick problem. Farmers are used to



dipping cattle. They are reluctant to dip goats and sheep. That attitude allows their livestock to easily succumb to tick borne diseases.

The views of the respondents concur with other studies which also show that communities in Africa grapple with what are called multiple stressors (Adger et al. 2003; Osbahr et al. 2008; Drimie and Gillespie 2010). Multiple stressors (in this case predatory animals and thieves) are other challenges that come about or are in existence when communities are attempting to adapt to climate change. These multiple stressors complicate the ability of farmers to adapt to climate change smoothly. The AGRITEX official summarized the challenges faced by interviewed farmers when he remarked that:

There are a number of challenges faced by the small livestock farmers ranging from diseases, thieves, predators and lack of finance to buy treatment for their livestock. For most of the constraints that they face, nothing has been done much to help them. For fear of retribution through current legislation, they watch as their livestock are mauled by the hyenas and jackals. They have not taken meaningful steps to address the diseases that affect their livestock. Thieves sometimes help themselves to their livestock and for those that are able to keep significant numbers they find themselves with a dilemma of markets to sell their livestock. (Key Informant 1, AGRITEX)

He however further suggested that the attitude of farmers also needs to be worked on. They do not classify themselves as goat farmers. They do not keep records. Livestock production is something to invest time and resources on. Few are taking steps to exploit the huge potential that lies with small livestock production. It was also apparent that interviewed farmers rear goats without an awareness of the type of breed which they keep. For all the interviewed farmers, a goat is appreciated just because it is a goat, what breed it is does not matter.

---

## **Institutional Mandate Response on Small Livestock Production**

The Livestock Veterinary Department in partnership with AGRITEX has been very instrumental in the study area in promoting small livestock rearing. The Livestock Veterinary Department offers technical support to the smallholder farmers at no charge to assist them to improve on small livestock production. Two household respondents from different wards remarked that:

The veterinary department has been very helpful to us as farmers in our village. They conduct training and workshops to teach us on small livestock breeding. We have been taught that are goats must be dosed and well-sheltered so that they are not exposed to too much heat and precipitation. Our goats are now dipping although some farmers still find it strange to do that because we grew up knowing it is cattle that dip. They respond fast even when there is an outbreak of a disease that affects our chickens as well. (Household Respondent 34, Makhasa)

I am one of the few farmers that have benefited from teachings facilitated by the Veterinary Department. I was trained at Maphisa to be a paravet for a week. Because of my passion in goat rearing I have over 50 goats now from the mere 14 I had before I was

trained. All my goats go for dipping every month. I dose them regularly. I have thus constructed this new kraal to prevent them from being mauled by hyenas and jackals. (Household Respondent 50, Zamanyoni)

However, another research participant in the study area had a different view on the role of the veterinary department. He exclaimed that:

Our Veterinary personnel are not well capacitated in our district in terms of resources to serve the farmers. They have lots of literature in their office but they have no transport to go around distributing the literature and equipping farmers as they should. They do not even have up to date statistics because they don't have the means to get to where the people are. (Household Respondent 22, Gwezha)

It was clear from the 67% interviewed farmers that the Livestock Veterinary Department is making great strides in capacitating smallholder farmers to enhance the production of small livestock in the study area. They acknowledged that they have received information through field visits on issues relating to small livestock dipping, dosing, climate friendly shelter, and dealing with diseases. However, 33% of the interviewed farmers felt that the department is limited by resource constraints from the central government. They argued that the technical experts from the veterinary rarely do field visits and that they only avail themselves during emergency situations such as disease outbreaks threatening small livestock. They also claimed that they occasionally come when they have a joint program with NGOs like World Vision. Given such a scenario, smallholder farmers are forced to be initiative and deal with some diseases using traditional medicine or fork out money to travel from their village to Maphisa Centre to get technical advice. There was also a concern that even if one travels to Maphisa, medicine is not readily available, and therefore farmers are compelled to further go to Bulawayo which is difficult due to financial constraints.

Khulasizwe (local NGO) which used to operate in the study area from 2009 to 2013 played a crucial role in the promotion of goat production. They mainly distributed three female goats per household to promote food security and create a market for Bulawayo butcheries where the demand for goat meat was high. The researcher identified two beneficiaries who had benefited from the Khulasizwe project. They commented that:

Khulasizwe gave me 3 goats in 2009. They also gave me and other beneficiaries cement, asbestos to build shelter for goats. Khulasizwe offered a 50/50 deal where you also paid half prize of stock and they paid the other half. They offered vaccines. This has improved livestock production in Matobo. I currently own 27 goats from the original 3 I received from Khulasizwe. (Household Respondent 49, Makhasa)

Goats have a huge potential of saving not only Matobo farmers but the whole nation from a potential disaster caused by climate change. There is therefore need for the government to help the small livestock farmers to go commercially and to produce for the nation. A little more of the government presence on the ground can make a huge difference. (Household Respondent 50, Makhasa)

---

## Conclusions

Farmers in the study area are agreed that goats and sheep have increased their adaptive potential in the face of adverse climatic condition. Unlike cattle, the survival rates of small livestock is high in the drought prone areas like Matobo District and have proved more viable and effective. Most households from the sample kept one form of small livestock irrespective of the knowledge on the breeds that they kept. The success and viability of small livestock production largely depend on the input of government and other stakeholders like the Department of Livestock Production and Development, Jairos Jiri, World Vision, and Khulasizwe working closely with farmers. Their contribution to farmers through expert training and provision of small livestock is key to successful adaptation. Therefore, that working relationship should be strengthened and maintained.

---

## Recommendations

Based on the above findings, this study recommends the following:

The government, at local and national level, can facilitate and implement adaptation strategies through policies that support farmers and make resources available. The government has documented action plans and strategies to tackle the challenges of climate change through the Ministry of Environment, Water and Climate. However, there is need for government to “walk the talk” and implement what is documented on paper and implement it on the ground. There is a discrepancy over what the government intends to do and what communities experience in their environment.

There is need for government and NGOs like AGRITEX, EMA, Department of Livestock Production and Development, World Vision, Khulasizwe, and Jairos Jiri to coordinate their activities. Research participants noted overlaps in how such programs are implemented. Coordination among them assists in avoiding or at least reduces overlap of activities. Climate change adaptation strategies if coordinated well can help in discovering of existing gaps in need of implementation.

Adoption of technical adaptation strategies like small livestock rearing should be broadened through knowledge dissemination and awareness in all wards. The challenge currently is that interventions target a few farmers and leave out others. Going forward, knowledge and training should be emphasized until communities fully appreciate the adaptation options suitable and appropriate for their areas. Raising awareness of climate change issues can be done through the local media and extension staff. Dissemination of climate change information from national and local meteorological stations to farmers through extension agents is also very critical.

## References

- Adger WN, Huq S, Brown K, Conway D, Hulme M (2003) Adaptation to climate change in the developing world. *Prog Dev Stud* 3(3):179–195
- Africa Partnership Forum (2008) Climate challenges to Africa: a call for action. Available from: <http://www.africapartnershipforum.org>
- Apraku A, Moyo P, Akpan W (2018a) Coping with climate change in Africa: an analysis of local interpretations in Eastern Cape, South Africa. *Dev South Afr*. <https://doi.org/10.1080/0376835X2018.1482199>
- Apraku A, Akpan W, Moyo P (2018b) Indigenous knowledge, global ignorance? Insights from an Eastern Cape Climate Change Study. *S Afr Rev Sociol* 49(2):1–21. <https://doi.org/10.1080/21528586.2018.1532813>
- Armitage D, Plummer R (2010) Integrating perspectives on adaptive capacity and environmental governance. In: *Adaptive capacity and environmental governance*. Springer, New York, pp 1–19
- Assan N (2014) Goat production as a mitigation strategy to climate change vulnerability in semi-arid tropics. *Sci J Anim Sci* 3(11):258–267
- Assan JK, Kumar P (2009) Introduction: livelihood options for the poor in the changing environment. *J Int Dev* 21(3):393–402. <https://doi.org/10.1016/j.foodpol.2008.01.003>
- Brazier A (2015) *Climate change in Zimbabwe facts for planners and decision makers*. Konrad Adenauer Stiftung, Harare
- Chaudhury M (2017) *Strategies for reducing vulnerability and building resilience to environmental and natural disasters in developing countries*. World Resources Institute, United Nations Department of Economic and Social Affairs, Division of Social Policy and Development, New York
- Cutter SL, Mitchell JT, Scott MS (2000) Revealing the vulnerability of people and places: a case study of Georgetown Country, South Carolina. *Ann Assoc Am Geogr* 90(4):713–737
- Cutter SL, Boruff BJ, Shirley WL (2003) Social vulnerability to environmental hazards. *Soc Sci Q* 84(2):242–261. <https://doi.org/10.1111/1540-6237.8402002>
- Downing TE, Patwardhan A (2004) Assessing vulnerability for climate adaptation. In: Lim B, Spanger-Siegfried E (eds) *Adaptation policy frameworks for climate change: developing strategies, policies, and measures*. Cambridge University Press, Cambridge
- Drimie S, Gillespie S (2010) Adaptation to climate change in Southern Africa: factoring in AIDS. *Environ Sci Pol* 13:778–784
- Dube T, Phiri K (2013) Rural livelihoods under stress: the impact of climate change on livelihoods in South Western Zimbabwe. *Am Int J Contemp Res* 3(5):11–25
- Dube T, Moyo P, Intauno S, Phiri K (2017) The gender-differentiated impacts of climate change on rural livelihoods labour requirements in Southern Zimbabwe. *J Hum Ecol* 58(1–2):48–56
- Dube T, Mlilo C, Moyo P, Ncube C, Phiri K (2018) Will adaptation carry the future? Questioning the long-term capacity of smallholder farmers' adaptation strategies against climate change in Gwanda District, Zimbabwe. *J Hum Ecol* 61(1–3):20–30
- Dulal HB, Brodnig G, Thakur HK, Green-Onoriose C (2010) Do the poor have what they need to adapt to climate change? A case study of Nepal. *Int J Justice Sustain* 15(7):621–635
- Fussel HM, Klein RJT (2006) Climate change vulnerability assessments: an evolution of conceptual thinking. *Clim Chang* 27:301–329. <https://doi.org/10.1007/s10584-006-0329-3>
- Girum G, Degefa T, Getachew G (2008) Risk perception and coping strategies among the Karrayu pastoralists of upper Awash Valley, Central Ethiopia. *Nomadic People* 12:93–107
- Gukurume S (2013) Climate change, variability and sustainable agriculture in Zimbabwe's rural communities. *Russ J Agric Socio-Econ Sci* 2(14):89–93
- Intergovernmental Panel of Climate Change (2007) *Climate change 2007: impacts, adaptation and vulnerability*. Working group II contribution to the Fourth Assessment Report of the Intergovernmental Panel on Climate Change. Cambridge University Press, Cambridge
- International Union for Conservation of Nature (2010) *Building climate change resilience for Africa livestock in sub-Saharan Africa*. World Initiative for Sustainable Pastoralism, Nairobi

- Kaasschieter GA, de Jong R, Schiere JB, Zwart D (1992) Towards sustainable livestock production in developing countries and the importance of animal health strategy therein. *Vet Q* 14(2):66–75
- Kahsay AG, Hansen LG (2016) The effects of climate and adaptation policy on agricultural production in Eastern Africa. *Ecol Econ* 121:54–64
- Khulasizwe Small Livestock Production in Matobo District (2018) Quartely Report. Unpublished
- Leichenko RM, O'Brien KL (2002) The dynamics of rural vulnerability to global change: the case of Southern Africa. *Mitig Adapt Strateg Glob Chang* 7:1–18
- Makuvaro V, Walker S, Munodawafa A, Masere TP, Murewi C, Chagonda I (2014) An overview of current agronomic practices of smallholder farmers in semi-arid Central and Western Zimbabwe. *Afr J Agric Res* 9(35):2710–2720
- Mano R, Nhemachena C (2006) Assessment of the economic impacts of climate change on agriculture in Zimbabwe: a Ricardian approach. CEEPA discussion paper no. 11. Centre for Environmental Economics and Policy in Africa, Pretoria
- McBean GA (2012) Integrating disaster risk reduction towards sustainable development. *Environ Sustain* 4:1–6
- Moss RH, Brenkert AL, Malone EL (2001) Vulnerability to climate change: a quantitative approach. Technical report PNNL-SA-33642, Pacific Northwest National Laboratories, Richland
- Munhande C, Mapfungautsi R, Mutanga P (2013) Climate risk management: actors, strategies and constraints for smallholder farmers in Zimbabwe: a case study of Chivi District. *J Sustain Dev Afr* 15(8):240
- Musarurwa L, Lungu W (2012) Climate change mitigation and adaptation: threats and challenges to livelihoods in Zimbabwe. *Asian J Soc Sci Humanit* 1(2):25–32
- Mutekwa V, Kusangaya S (2006) The contribution of rainwater harvesting techniques to rural livelihoods in Zimbabwe: the case of Ngundu Ward in Chivi District. *Bull Anim Health Prod Afr* 32(3):437–452
- Nandhini DU, Suganthi S (2018) Livestock importance in organic farming. *Approaches in Poverty, Dairy and Veterinary Sciences* 5(1). <https://doi.org/10.31031/APDV.2018.05.000602>
- Ndlovu L (2010) Food, nutrition and health. In: Swanepoel FJC, Stroebel A, Moyo S (eds) *The role of livestock in developing communities: enhancing multifunctionality*. CTA, Wageningen
- Ndlovu S, Mpfu M, Moyo P (2019) Debunking the effectiveness of in-kind transfers in alleviating urban household food insecurity in Bulawayo, Zimbabwe. *Dev South Afr*. <https://doi.org/10.1080/0376835X.2019.1584031>
- Nyong A (2009) Climate change impacts in the developing world: implications for sustainable development. In: Brainard L, Jones A, Purvis N (eds) *Climate change and global poverty: a billion lives in the balance?* Brookings Institution Press, Washington, DC
- Osbahr H, Twyman C, Adger WN, Thomas DSG (2008) Effective livelihood adaptation to climate change disturbance: scale dimensions of practice in Mozambique. *Geoforum* 39(6):1951–1964
- Phiri K, Ndlovu S, Chiname TB (2014) Climate change impacts on rural based women: emerging evidence on coping and adaptation strategies in Tsholotsho, Zimbabwe. *Mediterr J Soc Sci* 5(23):2545–2552
- Phiri K, Dube T, Moyo P, Ncube C, Ndlovu S (2019) Small grains “resistance”? Making sense of Zimbabwean smallholder farmers’ cropping choices and patterns within a climate change context. *Cogent Social Sciences* 5(1):1622485
- Prowse M, Scott L (2008) Assets and adaptation: an emerging debate. *IDS Bull* 39(4):42–52
- Shah KU, Dulal HB, Johnson C, Baptiste A (2013) Understanding livelihood vulnerability to climate change: applying the livelihood vulnerability index in Trinidad and Tobago. *Geoforum* 47:125–137
- Smit B, Burton I, Klein RJT, Wandel J (2000) An anatomy of adaptation to climate change and variability. *Clim Chang* 45:223–451
- Turner BL, Kasperon RE, Matson PA, McCarthy JJ, Corell RW, Christensen L, Eckley N, Kasperon JX, Luers A, Martello ML, Polsky C, Pusipher A, Yauch CA, Steudel HJ (2003) Complementary use of qualitative and quantitative cultural assessment methods. *Organ Res Methods* 6(4):465–481

- United Nations (2004) Living with risk: a global review of disaster reduction initiatives. United Nations International Strategy for Disaster Reduction, Geneva
- Van Aelst K, Holvoet N (2016) Intersections of gender and marital status in accessing climate change adaptation: evidence from rural Tanzania. *World Dev* 79C:40–50
- Watts MJ, Bohle HG (1993) The space of vulnerability: the causal structure of hunger and famine. *Prog Hum Geogr* 17(1):43–67
- World Vision (2015) Goat Rearing in Matobo District, Zimbabwe, Annual Report. Unpublished
- Zimbabwe's National Climate Change Response Strategy (2014) Government of Zimbabwe Ministry of Environment, Water and Climate: annual report. Institute of Environmental Studies, Harare
- ZIMSTAT (2013) Poverty and poverty datum line analysis in Zimbabwe 2011/12. ZIMSTAT, Harare

**Open Access** This chapter is licensed under the terms of the Creative Commons Attribution 4.0 International License (<http://creativecommons.org/licenses/by/4.0/>), which permits use, sharing, adaptation, distribution and reproduction in any medium or format, as long as you give appropriate credit to the original author(s) and the source, provide a link to the Creative Commons license and indicate if changes were made.

The images or other third party material in this chapter are included in the chapter's Creative Commons license, unless indicated otherwise in a credit line to the material. If material is not included in the chapter's Creative Commons license and your intended use is not permitted by statutory regulation or exceeds the permitted use, you will need to obtain permission directly from the copyright holder.





# Barriers to Climate Change Adaptation Among Pastoralists: Rwenzori Region, Western Uganda

# 35

Michael Robert Nkuba, Raban Chanda, Gagoitseope Mmopelwa, Akintayo Adedoyin, Margaret Najjingo Mangheni, David Lesolle, and Edward Kato

## Contents

Introduction .....	660
Methods .....	662
Study Area .....	662
Data Collection Methods and Sample Size .....	663
Results and Discussion .....	664
Socioeconomic Characteristics .....	664
Barriers to Climate Change Adaptation among Pastoralists .....	666
Sources of the Barriers .....	668
Origins of the Barriers .....	670

This chapter was previously published non-open access with exclusive rights reserved by the Publisher. It has been changed retrospectively to open access under a CC BY 4.0 license and the copyright holder is “The Author(s)”. For further details, please see the license information at the end of the chapter.

M. R. Nkuba (✉) · R. Chanda · G. Mmopelwa · D. Lesolle  
Department of Environmental sciences, Faculty of Science University of Botswana, Gaborone, Botswana  
e-mail: [mnkuba@gmail.com](mailto:mnkuba@gmail.com); [chandar@mopipi.ub.bw](mailto:chandar@mopipi.ub.bw); [gmmopelwa@mopipi.ub.bw](mailto:gmmopelwa@mopipi.ub.bw); [david.lesolle@mopipi.ub.bw](mailto:david.lesolle@mopipi.ub.bw)

A. Adedoyin  
Department of Physics, Faculty of Science, University of Botswana, Gaborone, Botswana  
e-mail: [akintayo\\_adedoyin@yahoo.com](mailto:akintayo_adedoyin@yahoo.com)

M. N. Mangheni  
Department of Extension and Innovation Studies, College of Agricultural and Environmental Sciences, Makerere University Kampala, Kampala, Uganda  
e-mail: [mnmangheni@gmail.com](mailto:mnmangheni@gmail.com)

E. Kato  
International Food Policy and Research Institute, Washington, DC, USA  
e-mail: [E.Kato@cgiar.org](mailto:E.Kato@cgiar.org)

Enablers of Adaptation in Uganda .....	672
Conclusion .....	673
References .....	673

## Abstract

This chapter discusses the barriers to climate change adaptation among pastoralists in the Rwenzori region in Western Uganda. Despite the implementation of adaptation programs by public and private agencies, pastoralists still have impediments to adapting to climate change. Data was collected using a household survey involving 269 pastoralists. The results revealed that the main barriers were poor access to climate change information, poor access to extension services, high cost of adaptation measures, poor access to credit, and insecure land tenure. There is need to improve capacity building of extension workers and other stakeholders in the dissemination of climate change information. Land tenure and land rights issues should be given high consideration in climate change adaptation policies and programs. Climate finance programs should be made more effective in addressing the high cost of adaptation.

## Keywords

Barriers · Adaptation · Climate change · Pastoralists · Rwenzori · Uganda

## Introduction

Climate change is one of the greatest threats to achieving the sustainable development goals related to eradicating poverty and hunger and ensuring clean water and life on land in Africa (IPCC 2018c). Despite the increased efforts at both national and international levels in the form of climate finance and programs, pastoralists still have barriers to adapting to climate change. Failure to adapt to climate change has resulted into high livestock mortality leading to a poor quality of life among pastoral households (IPCC 2014b). The impacts of global warming of 1.5 °C above pre-industrial levels are likely to lead to an increase in droughts and floods in Africa, especially in pastoral areas (IPCC 2018a). This could result in a failure to achieve sustainable development goals (IPCC 2018c). Pastoralists have adapted to climate change with various strategies that include livestock diversification, destocking, livestock migration, and engagement in nonfarm enterprises (Greenough 2018; IPCC 2014b). However, some pastoral households have been more vulnerable than others to climate change, resulting in loss of livestock (Greenough 2018). This implies that there are hindrances to adaptation.

Developing countries such as those in Africa still have challenges in addressing the hindrances, leading to an adaptation deficit when compared to developed countries in Europe (IPCC 2014a; Shackleton et al. 2015). These hindrances are categorized as limits and barriers. Barriers refer to impediments that can be easily



overcome, while limits refer to impediments that cannot be easily overcome (IPCC 2014a). Many scholars have written about the barriers to adaptation without scrutinizing their causes (Filho and Nalau 2018; Shackleton et al. 2015). Moser and Ekstrom (2010) argue that barriers have various causes which have to be addressed for successful adaptation to be achieved. The issues of concern include the context of the pastoral household, type of pastoral household, and the governance system of the natural resource. This suggests that smallholder pastoralists experience different barriers compared to large-scale pastoralists. Rangeland policies that promote sedentary pastoralism have different barriers compared to those that promote mobile pastoralism (Löf 2013; Shackleton et al. 2015). These policies have strong implications for the governance system and context of pastoralism. For example, sedentary policies in pastoralism have a detrimental effect on the land tenure system that does not promote herd mobility as a coping mechanism for droughts (Little et al. 2008). This then becomes a barrier.

The barriers that have been identified include economic, biophysical, financial, informational, sociocultural, governmental, and institutional (Alam et al. 2018; Antwi-Agyei et al. 2015; IPCC 2014a; Shackleton et al. 2015). Juana et al. (2016) reported that barriers identified among livestock farmers in Botswana included poor access to improved technology; lack of land, extension workers, credit, and markets; and government restrictions on land use. Muller and Shackleton (2014) showed that the main barriers to commercial livestock farmers in semiarid East Cape in South Africa were poor access to finance, lack information on climate change adaptation and climate information, and lack of government support. This shows that there are barriers that are unique to livestock farmers and pastoralists.

The “barrier to adaptations” diagnostic framework was used to analyze the causes of the barriers (Moser and Ekstrom 2010). This was in order to have a robust investigation of the causes of the barriers, leading to measures of overcoming them. The analysis took into account the sources of the barriers that include the pastoralists (actors), context (governance and economic setting), and socio-ecological system in the rangelands (system of concern) (Moser and Ekstrom 2010). The larger context refers to the level of socioeconomic development and the control of information flow at national and local government level associated with climate change adaptation. Governance refers to the laws, policies, implementation frameworks, and resource allocation at national and local government levels that are associated with the socio-ecological system. The socio-ecological system refers to rangelands, herdsman, and pastoral households. The socio-ecological system produces signals of environmental change (Moser and Ekstrom 2010) in terms of floods and droughts, although droughts have slow onset and may not be easily detected by the pastoralists. Early warning systems such as seasonal climate forecasts that are disseminated via mass media are not usually observed (Luseno et al. 2003). Pastoralists tend to use indigenous forecasts in their adaptation to extreme weather events despite their reliability and accuracy being affected by climate change (Speranza et al. 2010). Some pastoralists use both indigenous and scientific forecasts (Lybbert et al. 2007). The

analysis also took into consideration the temporal dimension of the barrier sources, which include recent occurrence (contemporary issue) or occurrence over a long time (legacy issue) (Moser and Ekstrom 2012). The purpose was to find out when the barriers came into play. The spatial jurisdiction origin of the barrier in relation to pastoralists includes proximate, referring to the origin of the barrier being within pastoralists' cycle of influence, and remote, referring to the origin of the barrier being outside the pastoralists' cycle of influence, for example, government policies (Moser and Ekstrom 2010). The idea was to examine which barriers were within the cycle of influence of the pastoralists.

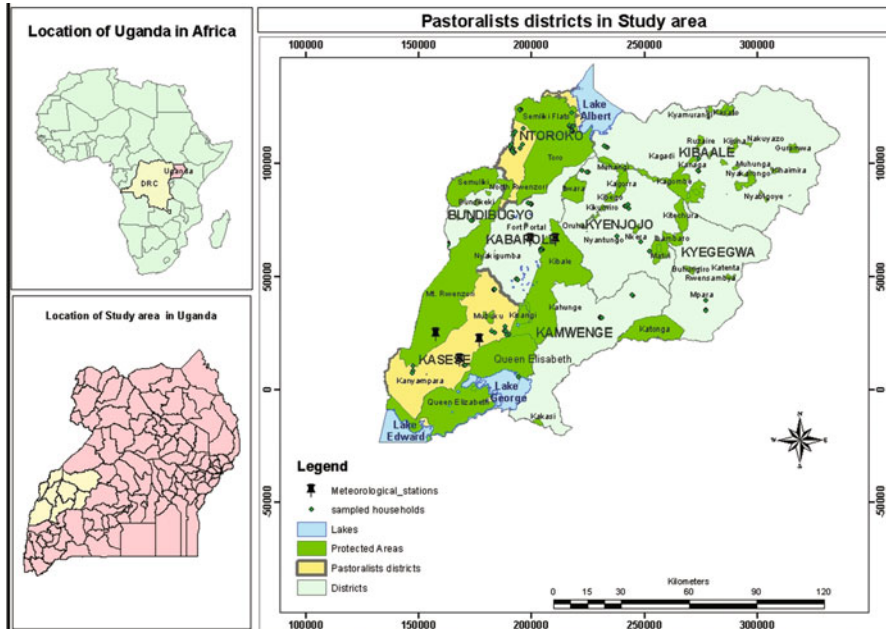
This chapter examines the barriers to adaptation among pastoralists in the Rwenzori region in Western Uganda. The key question is what are barriers to adaptation among pastoralists? The sources and origins of the barriers are examined to provide strategies for overcoming them. The objective is to generate empirical evidence that could be used by policymakers, development partners, extension workers, and nongovernmental organizations to address the barriers among pastoralists to improve their adaptation to climate related risks. The chapter contributes to pastoral literature that relates to barriers to climate change adaptation in Africa. The scope of this chapter addresses barriers among pastoralists in the tropical equatorial region in Western Uganda and does not cover arable farmers and pastoralists in semiarid areas.

---

## Methods

### Study Area

The study on barriers to adaptation among pastoralists was conducted in Kasese and Ntoroko districts found in the Rwenzori region in Western Uganda (Fig. 1). There are a few weather stations used to provide the climate data of the region. The rangelands in the study area are conducive to pastoralism and wildlife conservation, and wildlife protected areas (WPAs) exist in the area. WPAs include Queen Elisabeth National Park in Kasese district and Tooro-Semiliki Game Reserve in Ntoroko district (Fig. 1). As an adaptation strategy for climate change, pastoralists migrate to the eastern part of the Democratic Republic of Congo. Political instability in Eastern DR Congo tends to cause large numbers of pastoralists to migrate back to Uganda (KRC and RFPJ 2012). However, some pastoralists illegally graze in WPAs. The Uganda Wildlife Authority imposes heavy penalties on pastoralists who illegally graze in WPAs. The emphasis on sedentary pastoralism in government rangeland policies has led to a reduction in mobile pastoralism in Uganda (Wurzinger et al. 2006, 2009). The region has a bimodal rainfall distribution and experiences droughts and floods with increased frequency (NAPA 2007).



**Fig. 1** Location map of study area. (Source: Michael Robert Nkuba)

### Data Collection Methods and Sample Size

Data collection took place from August to October 2015 in the Rwenzori region. Household surveys gathered data on barriers to adaptations, socioeconomic characteristics, and use of indigenous forecasts (IFs) and/or scientific forecasts (SFs). A two-stage stratified sampling design was used (Cochran 1963), in which the strata were the districts and the second stage units were households. Stratified sampling was based on farming systems and agro-ecosystems in the Rwenzori region. Random sampling was used to select the respondents for the survey. The sample size was 778 households, with a 95% confidence level and a margin of error of 3.5%, based on the total population of the study area (the Rwenzori region and the Kibale district) of 102,496 households, according to Uganda population census report 2014. However, to allow for replacement in the sample of those who might back out of the study, and have good sizes for subsamples for those who use IF and SF and IF only, 19% of the statistically selected sample was included, giving a total study sample of 924. This was also to ensure a good sample size for subsamples (for those who use IF and SF and IF only). After data cleaning, 17 questionnaires were excluded from the analysis due to incomplete responses. Of the remaining 907 respondents, 580 were arable farmers, 269 pastoralists, and 57 agro-pastoralists. For this chapter, the sample size is 269 from pastoral areas in Kasese and Ntoroko districts. Data was analyzed

using Stata 12. The scope of this chapter addresses barriers among pastoralists in the tropical equatorial region in Western Uganda and does not cover arable farmers and pastoralists in semiarid areas.

## Results and Discussion

### Socioeconomic Characteristics

The descriptive characteristics show that respondents were mostly male (59%) (Table 1) with an average number of local cows produced in the previous last 12 months being 70 per pastoral household. Pastoralists mainly used both IFs and SFs (59%) or IFs only (41%) in their adaptation to climate-related risks (Table 2). The use of indigenous forecasts has enhanced climate change adaptation and disaster

**Table 1** Socioeconomic characteristics of respondents

Variable	Variable definition	Full sample ( <i>N</i> = 269)
Female	Gender of the respondent (1 if female)	0.41
Male	Gender of the respondent (1 if male)	0.59
No school	Respondent had no formal school education (1 if yes)	0.38(0.50)
Primary	Respondent attained primary education (1 if yes)	0.47(0.50)
Secondary education	Respondent attained ordinary or advanced secondary education (1 if yes)	0.12(0.33)
Farm experience	Farming experience of the respondent in completed years	27.72(13.84)
Age	Age of the respondent in completed years	44.26(13.25)
Kasese	Respondent resides in Kasese district (1 if yes)	0.17(0.38)
Ntoroko	Respondent resides in Ntoroko district (1 if yes)	0.81(0.40)
Drought experience	Respondent has had drought experience (1 if yes)	0.96(0.20)
Flood experience	Respondent has had flood experience (1 if yes)	0.82(0.39)
Herd mobility	Respondent practices herd mobility (1 if yes)	0.55(0.50)
Livestock diversification	Respondent practices livestock diversification (1 if yes)	0.54(0.50)
Livestock migration	Respondent practices livestock migration (1 if yes)	0.83(0.38)
Selling livestock	Respondent practices selling livestock (1 if yes)	0.51(0.50)
Well construction	Respondent practices well construction (1 if yes)	0.31(0.46)
Nonfarm	Respondent engages in nonfarm enterprises (1 if yes)	0.08(0.27)
Owns boats	Owns boats (1 if yes)	0 0.11(0 0.32)
Owns fishnet	Owns fishnet (1 if yes)	0.10(0 0.30)
Local cattle produced last 1 year	Local cattle produced in the last 12 months (numbers)	69.97(58.56)

Source: Field data 2015 Figures in parentheses are standard deviations

**Table 2** Use of IF only and IF and SF by pastoralists in the Rwenzori region

	Onset (%)		Cessation (%)		5-day (%)		Seasonal (%)		Total
	Full sample	Subsample	Full sample	Subsample	Full sample	Subsample	Full sample	Subsample	
IF and SF	50	84	43	73	35	59	30	50	59
IF only	40	99	38	95	33	82	24	60	41

Source: Survey data 2015 Full sample = 269, subsample IF and SF = 160, subsample IF only = 108

**Table 3** Pastoralists' land tenure and access to land

Variable	Variable definition	Full sample ( <i>N</i> = 269)
Customary	Customary (1 if yes)	0.34(0.47)
Freehold	Freehold (1 if yes)	0.14 (0.35)
Inheritance	Inheritance (1 if yes)	0.40(0.49)
Purchased	Purchased (1 if yes)	0.33(0.47)
Grabbed	Grabbed (1 if yes)	0.05(0.22)

Source: Survey data 2015 Figures in parentheses are standard deviations

**Table 4** Barriers to climate change adaptation among pastoralists

	Mean	Std. Dev.
Inadequate or no access to extension services	0.27	0.44
Inadequate or no information on climate change	0.49	0.50
Lack of access to credit facilities	0.18	0.38
Insecure land tenure or property rights	0.09	0.29
High cost of hired labor	0.15	0.36
High cost of adaptation measures	0.26	0.44
Labor shortages	0.08	0.27
No barrier	0.04	0.20

Source: Field Data 2015

management in Africa and South America (IPCC 2018b). Climate-related risks experienced were floods and droughts. The majority (47%) had attained primary education, and 38% had no formal education. The common adaptation methods were livestock migration, herd mobility, livestock diversification and livestock sales. Enablers to adaptation included access to land through purchasing (suggesting that functional land markets existed) and inheritance (Table 3). Pastoralists diversified their livelihoods to include other natural resources such as fisheries resources, which were demonstrated by ownership of boats and fishnets (Table 1).

### Barriers to Climate Change Adaptation among Pastoralists

The high cost of adaptation is a major barrier in wealthy pastoral households (Table 4). According to a key informant, it costs \$800 to construct a private dam, and sinking a borehole would cost \$5400 in the study area. These costs are high for smallholder pastoralists. The key informant also said that the government program, National Agricultural Advisory Services (NAADS), used to provide fence materials to a few model pastoralists. The NAADS program ended in 2014, and the cost of infrastructure development in pastoral areas is high. The fencing materials were provided to a few pasture demonstration farmers (Dalipagic and Elepu 2014; GoU 2018). The government also provided tractors for pasture improvement but not water

for pastoralists (NAADS 2017). Climate finance should address such barriers. The Uganda government provided support for the construction of over 650 communal valley dams and 135 private dams for ranches in the rangelands (Nema 2001). Some of these dams dried up during droughts resulting in livestock mortality and an increase in herd mobility (Zziwa et al. 2012). Lack of hydrographic surveys for communal valley dams, poor designing of water sources without taking into account the rangeland dynamics and context, poor maintenance, and lack of community ownership were the main factors that led to the poor performance of communal valley dams (Mugerwa et al. 2014; Nema 2001). Community involvement in the management of micro-dams is higher in the Southwest and Central regions of Uganda (40–50%) than in the North and Northwest regions, where it is very low (less than 10%) (Bashar et al. 2004).

The poor performance of valley dams has increased water scarcity in the rangelands, resulting in an increase of mobile pastoralism and sociopolitical conflicts (Nema 2007), yet the government built the water sources to promote sedentary pastoralism. Even in situations where there was good performance and management of the dams, there was land degradation of the rangelands surrounding the water source (Egeru et al. 2015). Individual pastoralists tend to manage their private water sources better than they manage communal ones. The Botswana government provides support to livestock farmers with infrastructural development assistance, such as for fencing materials, and construction of boreholes to improve their adaptive capacity against droughts (Pauw 2013). Climate finance should support pastoral initiatives toward adaptation by providing fencing materials and sustainable water sources in communal rangelands and paddocks (Denton 2010).

Poor access to climate change information and poor access to extension services were also important barriers to adaptation among pastoral households. Extension workers have not mainstreamed climate change information in their dissemination of extension messages, but emphasis has been put on livestock production (AfranaaKwapong and Nkonya 2015; GoU 2016; Nkonya et al. 2015). Furthermore, in Uganda (as elsewhere in Africa) the extension system has gone through many changes from a unified extension system (1981–2000) to a demand-driven extension under the NAADS (2001–2014), to the current single-spine extension system (2015 to date) (Barungi et al. 2016; GoU 2016; Rwamigisa et al. 2018). The extension services have been tailored to sedentary but not mobile pastoralism. The demand-driven extension system under NAADS was relevant not to mobile pastoralists but to sedentary pastoralists. The extension did not serve all the pastoralists but concentrated on a few, especially model farmers (AfranaaKwapong and Nkonya 2015; GoU 2016). Furthermore, pastoralists in remote areas did not access extension services (AfranaaKwapong and Nkonya 2015). There were also a limited number of qualified service providers in rural areas, resulting in services engaging unskilled and poor quality providers (Feder et al. 2011; GoU 2016). Most of the service providers had such a narrow scope of the subject matter that they were incompetent and lacked capacity to handle other aspects such as plant and animal diseases (GoU 2016; Rwamigisa et al. 2018). There was reportedly much political interference with the implementation of demand-driven extension service (Joughin and Kjær 2010;

Rwamigisa et al. 2018). This included the use of members of the Uganda Peoples Defence Forces in the distribution of inputs and various presidential directives on the implementation of the extension services, especially during election periods (Rwamigisa et al. 2018).

Poor access to credit facilities as a barrier mostly applied to small-scale sedentary pastoralists. Large-scale pastoralists tended to finance their livestock enterprises through destocking, using rural livestock markets (Bryan et al. 2013). Furthermore, these pastoralists diversified into fishing and other nonfarm enterprises (Nkuba and Sinha 2014). The large-scale pastoralists were much more involved in livestock migration to the DR Congo as a means of adapting to climate-related risk. During severe droughts, large-scale pastoralists incur losses but recover much more quickly than small-scale pastoralists (Little et al. 2001). According to key informants, about 10,000 cattle were lost in the Ntoroko district during the severe drought of 2011. In some cases, smallholders tend to resort to agro-pastoralism in a sedentary life after high livestock mortality due to severe drought (Berhanu and Beyene 2015).

Insecure land tenure or property rights (Table 4) was another barrier to climate change adaptation in pastoralism. The rangeland policy in Uganda supports sedentary pastoralism (Byakagaba et al. 2018), while pastoralists with land enjoy dual grazing rights. During the rainy season, they graze their livestock in the paddocks. However, during pasture and water scarcity periods, such as during long dry spells and droughts, they graze communally. The areas that used to be grazed communally have been taken up by crop farmers and wealthy pastoralists who have paddocks. Over the years, “the commons” have therefore shrunk in the Rwenzori region, yet the cattle population has not decreased substantially (GoU 2006). During political instability in the DR Congo, the livestock population in rangelands of Ntotoko is much higher than its carrying capacity. The debate concerning having titled land in rangelands and communal grazing land in the cattle corridor continues. Dual grazing rights of wealthy livestock farmers who have access to large acreages have also been reported in Botswana as a coping mechanism during severe droughts (Perkins 1996).

Labor shortages and the associated high cost of labor for pastoralism (Table 4) have been caused by the labor dynamics in the study region. Most herdsmen are youth, many of whom have resorted to nonfarm activities such as motorcycle hire services (commonly called *bodaboda*) in rural areas. Furthermore, there has been a mass migration of the youth from pastoral households to urban centers and towns in search of so-called greener pastures. Thus, the high demand for herdsmen in the face of a diminished labor supply in rangelands has led to the high cost of labor. The labor of herdsmen is in high demand for such adaptation strategies as livestock migration to the DR Congo, herd mobility to River Semiliki, and pasture lands in the neighborhood of the protected areas.

## Sources of the Barriers

The question that remains is whether pastoralists can overcome these barriers. As noted earlier, to answer this question, the sources of barriers needed to be identified



using the barriers to adaptations diagnostic framework. The sources were then analyzed using the three structural elements in the framework, namely, the actors (referring to pastoralists), governance (referring to policies, implementation frameworks, and laws that govern adaptation or hinder it), and socio-ecological system (life in the rangeland, sometimes referred to as system of concern) (Moser and Ekstrom 2010). The three structural elements were used to examine strategies of overcoming the barriers, as is reflected in the following discussion.

The high cost of adaptation was due to the poor performance of valley dams, an insufficient number of water sources in the rangelands, policy emphasis on support for communal water sources at the expense of individual pastoralists, and equity concerns where support was only given to a few model pastoralists. This suggests that the sources of barriers were principally governance (institutional), technological, and human resource concerns. As a solution, pastoralists could be supported in infrastructure development such as fencing and construction of dams (in communal rangelands) and of boreholes in paddocks for sedentary pastoralists using climate finance from both national and international agencies. The recent change in extension policy from demand-driven extension to single-spine may also help mainstream climate change in its implementation and take into account cost of adaptation (GoU 2016). This implies an increase in allocation of resources related to climate change adaptation. The poor performance of valley dams had a bearing on the hydrological dynamics in rangelands, implying that the socio-ecological system was also a source of barrier. This can be overcome by making good use of the available expertise in hydrology to carry out feasibility studies before the water sources are constructed. Human resources in hydrology and appropriate technology for the various agro-ecological zones from the Ministry of Water and Environment should be utilized to good effect, both in monitoring and in program design of water for agricultural production facilities (GoU 1999).

The source of barriers such as poor access to climate change information and poor access to extension services was governance (institutional concerns). From a governance perspective, rangeland and extension policies were not relevant to the context. Past extension policies, both the unified extension policy, which used the training and visit system, and the demand-driven policy under NAADS, did not meet the expected outcomes (Rwamigisa et al. 2018; World Bank 2007). This has been mitigated through the new extension policy based on the single-spine extension system, which also has mainstreamed climate change information in the extension messages (GoU 2016). However, the new rangeland policy is not compatible with the socio-ecological system (Byakagaba et al. 2018). Mobile pastoralism makes good use of fragile ecosystems in the rangelands under changing climate conditions (Bailey and Brown 2011; Weber and Horst 2011). Instead, the ultimate goal of the new policy is to convert hitherto mobile pastoralists into agro-pastoralists and sedentary farmers (Wurzinger et al. 2009). There is therefore need to lobby the policy-makers to take into account both mobile and sedentary pastoralism in the rangeland policy. There is also the problem of inadequate human resources in terms of extension officers to serve the entire country. Only 35% of the technical positions in local governments had been filled in 2016 (GoU 2016). This can be overcome

through increased supply and recruitment of qualified labor from tertiary agricultural institutions in the country, such as Makerere University and Bukalasa Agricultural College. Provision of incentives to extension staff is also critical to achieving sustainable outcomes.

Poor access to credit facilities is an actor-centric barrier. This can be overcome with pastoralists joining savings and credit organizations dedicated to pastoralists (Mpiira et al. 2014), probably supported by climate finance arrangements.

Insecure land tenure or property rights are governance-related barriers arising from concern related to the contradictory rangelands and land-use policies. The land policy promotes mobile pastoralism (GoU 2013) while land-use and rangeland policies discourage mobile pastoralism (GoU 2006); hence there is lack of policy coherence. This is another reason to lobby for change in the land-use and rangeland policies to take into account mobile pastoralism concerns.

The high cost of labor and labor shortages are governance-related and actor-centric barriers. From the governance perspective, there is a need for government policies that attract youth in rural areas of rangelands. The Ugandan government has passed a minimum wage law, but it is unclear how effective it will be in rangelands. From the actor perspective, pastoralists need to increase the amount of wages paid to herdsmen to attract more youth in the socio-ecological system.

### Origins of the Barriers

The origins of the barriers were investigated using temporal and spatial analysis (Table 5).

Lack of credit is a contemporary and proximate barrier, implying that it is within the cycle of influence of pastoralists and a more recent barrier that can be overcome. Wealthy pastoralists finance their enterprises from destocking using rural livestock markets. Destocking is also a climate change adaptation strategy. Thus, poor access to credit mostly applies to the poor sedentary pastoralists. There has been prevalence of savings and credit organizations (SACOs) in rural areas even among pastoralists (Mpiira et al. 2014).

The high cost of hired labor is a contemporary and legacy barrier, implying it is within the cycle of influence of pastoralists and has been in play over a long time. The rural-urban migration of youth in the socio-ecological system has led to an

**Table 5** Opportunities for influence and intervention to overcome the barriers

		Temporal	
Spatial Jurisdictional		Contemporary	Legacy
	Proximate	Lack of access to credit	High cost of hired labor
	Remote	Insecure land tenure, high cost of adaptation	Inadequate or no access to extension services Inadequate or no information on climate, labor shortages

Source survey data 2015. Adapted from Moser and Ekstrom (2010)

increase in the cost of labor. The youth nowadays prefer to engage in nonfarm activities such as the motorcycle hire business (popularly known locally as *bodaboda*), and move to urban centers. The promotion and implementation of universal primary education (UPE) even in pastoral areas has improved the skills of youth and provided opportunities outside the rangelands (Appleton 2001). Before the implementation of UPE, the cost of labor was very low as the supply of labor was high because many youth did not go to school. This barrier can be overcome by encouraging pastoralists to destock and by enabling them to obtain credit to finance their labor needs.

Insecure land tenure or property rights and the high cost of adaptation are contemporary and remote barriers, implying that they are a recent occurrence but outside the cycle of influence among the pastoralists due to change in government policies. Mobile pastoralism was commonly practiced in the cattle corridor in Uganda. The increase in human and livestock populations and conflicts among pastoralists and with pastoralists in the neighboring arable farming communities resulted in a change of government support, from mobile pastoralism to sedentary pastoralism. The change in rangeland land policy from mobile pastoralism to sedentary pastoralism is a result of armed conflict between arable farmers (from Teso) and pastoralists (the Karamanjong) in northeastern parts of Uganda. Before 1980, mobile pastoralism thrived in Uganda, until the Karamanjong got access to arms, which led to armed conflict in the rangelands (USAID 2011). The change in the land policy and act, with an emphasis on titling land, resulted in the shrinking of the commons in the rangelands, in turn resulting in an increase in insecure land tenure among the commoners (GoU 2013). This barrier could be mitigated through amending the land policy to provide for common grazing lands in land policy in the rangelands and to avoid titling every piece of land in Uganda. This debate has been ongoing among the various nonstate actors since the enactment of the land act in 2004 (Byakagaba et al. 2018). Blanket policy recommendations did not take into account the local setting in different parts of the cattle corridor.

The high cost of adaptation can be overcome through an increase in climate finance to include support to more pastoralists who are not model farmers, as is the current practice under the NAADS implementation framework. There has been a change in the national extension policy from the demand-driven to the single-spine NAADS, which is more inclusive and has taken into account equity concerns (GoU 2016).

Poor access to extension services and climate change information and labor shortages are legacy and remote barriers, implying that they lie outside the cycle of influence of pastoralists and have been in existence over a long period of time. Extension services should have provided the climate change information to the pastoralists, but the ineffective demand-driven extension policy had detrimental outcomes on both. This has fortunately been mitigated through the change in extension policy from the demand-driven to single-spine model (GoU 2016). The new policy promotes mainstreaming climate change information and providing services to all pastoralists.

Labor shortages are due to the failure of a minimum wage law and effective rural development strategies to address the rural–urban migration in Uganda. As observed earlier, educated youth will no longer work for very low incomes as herdsmen in pastoral areas. Recently government passed a minimum wage law whose outcomes are yet to be evaluated in rangelands. It is hoped that this will serve to retain youth in rangelands and promote urban-rural migration among the youth that have already left for urban areas. There is need for government to implement effective rural development strategies that would make rural areas more attractive to the youth. So far, strategies such as the Plan for Modernisation of Agriculture have not been effective in reversing the rural-urban migration of the youth.

It is noteworthy that the remote barriers are due to national policies such as extension and land policies that were heavily influenced by donors such the World Bank (Deininger 2003; Deininger and Binswanger 1999; Rwamigisa et al. 2018). Local ownership, support to home-grown initiatives, and bottom-up approaches to climate change adaptation would enhance and facilitate the development of the adaptive capacity of pastoralists against these barriers (World Bank 2007).

## Enablers of Adaptation in Uganda

Alongside barriers to climate change adaptation, studies have also identified adaptation enablers (Azhoni et al. 2018), such as human resource, institutional, governance, and economic enablers (Moser and Ekstrom 2012). In Uganda, climate change adaptation enablers include the following:

- *Human resources*, such as extension staff and climate change adaptation researchers, pastoralists with indigenous knowledge of climate change adaptation and forecasts.
- *Institutions*, such as climate change units and climate change policy, research centers for agricultural innovations, the Uganda National Meteorological Authority that provides early warning information and seasonal climate forecasts, mass media that disseminates climate and climate change information (GoU 2015).
- *Economic*, such as national and local government resource allocations to climate change adaptation initiatives, donor support from Denmark, the United States, Ireland, the United Kingdom, Belgium, Norway, the World Bank, the United Nations Development Programme, support for climate-smart agriculture from the Food and Agricultural Organisation of the United Nations, nonstate actors such as nongovernment organizations implementing climate change adaptation initiatives at local government level such as Oxfam, World Vision, Care, Volunteer Effort for Development Concerns (GoU 2015).
- *Political will* both at national and local government levels and parliamentary fora on climate change. The government provides mechanisms for flexible and negotiated cross-border access to pastoral resources under the land policy, such as access to rangelands in Eastern DR Congo (GoU 2013).

## Conclusion

The study has established that the barriers to pastoralism are mainly actor-centric and governance concerns. The main barriers were poor access to climate change information, poor access to extension services, high cost of adaptation measures, poor access to credit, and insecure land tenure. Some of the policies under which pastoralism is practiced hinder adaptation to climate change. A change in the policies will enhance adaptation; for example, the recent change from the unified extension system and demand-driven extension system to the single-spine system will help in overcoming poor access to extension services and climate change information. Climate finance programs should be made more effective in addressing the high cost of adaptation. Enhancing social capital can help in overcoming poor access to credit. A change in land-use and rangeland policies will help in mitigating insecure land tenure. Coherence of land, land-use, extension, and rangeland policies will enhance pastoral adaptive capacity. It is noteworthy that there are several enablers for climate change adaptation in Uganda, which could be exploited to good effect.

The key lessons learned are that policies associated with climate change adaptation either hinder or enhance the adaptive capacity of pastoral households. Enhancing social capital such as pastoralists' savings and credit groups facilitates access to credit, which improves the capacity to overcome some barriers. Climate finance should be administered in an equitable manner to improve the adaptive capacity for both wealthy and poor households in rural areas.

Future prospects for overcoming barriers in developing countries lie in the identification of the origins and sources of the barriers for effective policy interventions. Policy coherence in climate change adaptation implementation is critical to achieving sustainable development goals, especially Goals 13 and 15, which address the problems of climate change and terrestrial ecosystems, respectively. Mainstreaming climate change in, and effective implementation of, rural development policies will improve the ability of pastoralists to overcome the barriers to climate change adaptation. Rangeland policies should promote both mobile and sedentary pastoralism.

**Acknowledgments** The authors are grateful for the support during the research from research assistants and the respondents who made this research a reality through their favorable cooperation. This research was self-financed by the lead author for data collection, and special thanks to Nassali Mercy Nkuba for moral support. We are grateful to Kabarole Research and Resource Centre for their collaboration during the field work and the Government of Uganda for permission to carry out the study. Special thanks to Susane Moser and Julia Ekstrom for the insights in the diagnostic framework. This research is part of PhD work for Michael Robert Nkuba, who wishes to thank the University of Botswana for waiving tuition costs.

---

## References

- AfranaaKwapong N, Nkonya E (2015) Agricultural extension reforms and development in Uganda. *J Agric Extd Ural Dev* 7(4):122–134
- Alam GM, Alam K, Mushtaq S, Khatun MN, Leal Filho W (2018) Strategies and barriers to adaptation of hazard-prone rural households in Bangladesh Limits to Climate Change Adaptation. Springer, Swirtezzland, (pp. 11–24)

- Antwi-Agyei P, Dougill AJ, Stringer LC (2015) Barriers to climate change adaptation: evidence from Northeast Ghana in the context of a systematic literature review. *Clim Dev* 7(4):297–309
- Appleton S (2001) What can we expect from universal primary education? In: Uganda's recovery: the role of farms, firms, and government. The World Bank, Washington, DC, pp 371–406
- Azhoni A, Jude S, Holman I (2018) Adapting to climate change by water management organisations: enablers and barriers. *J Hydrol* 559:736–748
- Bailey DW, Brown JR (2011) Rotational grazing systems and livestock grazing behavior in shrub-dominated semi-arid and arid rangelands. *Rangel Ecol Manage* 64(1):1–9
- Barungi M, Guloba M, Adong A (2016) Uganda's Agricultural Extension Systems: How appropriate is the Single Spine Structure? Research report No 15. Economic Policy Research Centre. Makerere University-Kampala
- Bashar K, Kizaa M, Chane B, Seleshi Y (2004) Assessment of existing micro dams in Ethiopia, Sudan and Uganda. Micro-dam Group Nile Basin Capacity Building Network River Engineering. River Structure Research Cluster. Addis Ababa
- Berhanu W, Beyene F (2015) Climate variability and household adaptation strategies in Southern Ethiopia. *Sustainability* 7(6):6353–6375
- Bryan E, Ringler C, Okoba B, Roncoli C, Silvestri S, Herrero M (2013) Adapting agriculture to climate change in Kenya: household strategies and determinants. *J Environ Manage* 114:26–35. <https://doi.org/10.1016/j.jenvman.2012.10.036>
- Byakagaba P, Egeru A, Barasa B, Briske DD (2018) Uganda's rangeland policy: intentions, consequences and opportunities. *Pastoralism* 8(1):7
- Cochran WG (1963) *Sampling Technique*. (Vol. 2nd Edition.). New York.: John Wiley and Sons Inc
- Dalipagic I, Elepu G (2014) Agricultural value chain analysis in northern Uganda: Maize, rice, groundnuts, sunflower and sesame. Against Hunger (ACF) International. Kampala, Uganda
- Deininger KW (2003) Land policies for growth and poverty reduction. World Bank Publications, Washington DC
- Deininger K, Binswanger H (1999) The evolution of the World Bank's land policy: principles, experience, and future challenges. *World Bank Res Obs* 14(2):247–276
- Denton F (2010) Financing adaptation in least developed countries in West Africa: is finance the 'real deal'? *Clim Pol* 10(6):655–671
- Egeru A, Wasonga O, MacOpiyo L, Mburu J, Tabuti JR, Majaliwa MG (2015) Piospheric influence on forage species composition and abundance in semi-arid Karamoja sub-region, Uganda. *Pastoralism* 5(1):12
- Feder G, Birner R, Anderson JR (2011) The private sector's role in agricultural extension systems: potential and limitations. *J Agribus Dev Emerg Econ* 1(1):31–54
- Filho WL, Nalau J (2018) Introduction: limits to adaptation. Springer, Cham
- Government of Uganda (GoU) (1999) National water Policy. Ministry of Water and Environment. Kampala, Uganda
- Government of Uganda (GoU) (2006) The Uganda National landuse Policy. Ministry of Land Housing and Urban Development Kampala, Uganda
- Government of Uganda (GoU) (2013) The Uganda National land Policy. Ministry of Land Housing and Urban Development Kampala, Uganda
- Government of Uganda (GoU) (2015) National climate change Policy. Ministry of Water and Environment. Kampala, Uganda
- Government of Uganda (GoU) (2016) National Agricultural Extension Policy. Ministry of Agriculture, Animal industry and Fisheries. Entebbe, Uganda
- Government of Uganda (GoU) (2018) Guidelines For Use Of Production And Marketing Grant By Local Governments For Fy 2018/19. Ministry of Agriculture, Animal industry and Fisheries. Entebbe, Uganda
- Greenough KM (2018) Pastoralists shifting strategies and perceptions of risk: post-crisis recovery in Damergou, Niger. In: Limits to climate change adaptation. Springer, Switzerland, pp 129–142
- IPCC (2014a) Climate change 2014: adaptation opportunities, constraints, and limits. Retrieved from Cambridge University Press, Cambridge, UK/New York

- IPCC (2014b) Climate change 2014: impacts, adaptation, and vulnerability. Part B: regional aspects. Retrieved from Cambridge University Press, Cambridge, UK/New York
- IPCC (2018a) Impacts of 1.5 °C of Global Warming on Natural and Human Systems. Retrieved from Cambridge University Press, Cambridge, UK/New York
- IPCC (2018b) Strengthening and implementing the global response. Retrieved from Cambridge University Press, Cambridge, UK/New York
- IPCC (2018c) Sustainable development, poverty eradication and reducing inequalities. Retrieved from Cambridge University Press, Cambridge, UK/New York
- Joughin J, Kjær AM (2010) The politics of agricultural policy reform: the case of Uganda. *Forum Dev Stud* 37(1):61–78
- Juana JS, Okurut FN, Makepe PM, Kahaka Z (2016) Climate change perceptions and adaptations for livestock farmers in Botswana. *Int J Econ Issues* 9(1):1–21
- KRC & RFPJ (2012) Stuck in the Mist: Contextual Analysis of the Conflicts in the Rwenzori Region. KRC (Kabarole Research and Resource Centre ) and RFPJ (Rwenzori Forum for Peace and Justice). Fort Portal, Uganda
- Little PD, Smith K, Cellarius BA, Coppock DL, Barrett C (2001) Avoiding disaster: diversification and risk management among East African herders. *Dev Chang* 32(3):401–433
- Little PD, McPeak J, Barrett CB, Kristjanson P (2008) Challenging orthodoxies: understanding poverty in pastoral areas of East Africa. *Dev Change* 39(4):587–611
- Löf A (2013) Examining limits and barriers to climate change adaptation in an Indigenous reindeer herding community. *Clim Dev* 5(4):328–339
- Luseno WK, Mcpeak JG, Barrett CB, Little PD, Gebru G (2003) Assessing the value of climate forecast information for pastoralists: evidence from Southern Ethiopia and Northern Kenya. *World Dev* 31(9):1477–1494. [https://doi.org/10.1016/S0305-750X\(03\)00113-X](https://doi.org/10.1016/S0305-750X(03)00113-X)
- Lybbert TJ, Barrett CB, Mcpeak JG, Luseno WK (2007) Bayesian herders: updating of rainfall beliefs in response to external forecasts. *World Dev* 35(3):480–497. <https://doi.org/10.1016/j.worlddev.2006.04.004>
- Moser SC, Ekstrom JA (2010) A framework to diagnose barriers to climate change adaptation. *Proc Natl Acad Sci* 107(51):22,026–22,031
- Moser SC, Ekstrom JA (2012) Identifying and overcoming barriers to climate change adaptation in San Francisco Bay. California Energy Commission. Sacramento, CA 95814, USA
- Mpiira S, Kiiza B, Katungi E, Tabuti J, Staver C, Tushemereirwe W (2014) Determinants of net savings deposits held in savings and credit cooperatives (SACCOs) in Uganda. *J Econ Int Financ* 6(4):69–79
- Mugerwa S, Kayiwa S, Egeru A (2014) Status of livestock water sources in Karamoja sub-region, Uganda. *Resour Environ* 4(1):58–66
- Muller C, Shackleton SE (2014) Perceptions of climate change and barriers to adaptation amongst commonage and commercial livestock farmers in the semi-arid Eastern Cape Karoo. *Afr J Range Forage Sci* 31(1):1–12
- NAADS (2017) NAADS Strategic Plan 2015/16 – 2019/20. Ministry of Agriculture, Animal industry and Fisheries. Entebbe, Uganda
- NAPA (2007) Uganda National Adaptation Plans of Action. Ministry of Water and Environment. Kampala, Uganda
- NEMA (2001) State of the Environment Report for Uganda 2001. National Environment Management Authority (NEMA), Kampala, Uganda
- NEMA (2007) State of the Environment Report for Uganda 2007. National Environment Management Authority (NEMA), Kampala, Uganda
- Nkonya E, Place F, Kato E, Mwanjololo M (2015) Climate risk management through sustainable land management in Sub-Saharan Africa. In *Sustainable Intensification to Advance Food Security and Enhance Climate Resilience in Africa*. Springer, Switzerland, (pp. 75–111)
- Nkuba MR, Sinha N (2014) Aquaculture and fishers' livelihood diversification in Uganda –an empirical analysis. Paper presented at the IASTED international conference environment and water resource management (AfricaEWRM 2014), Gaborone

- Pauw P (2013) The role of perception in subsistence farmer adaptation in Africa: enriching the climate finance debate. *Int J Clim Change Strategies Manage* 5(3):267–284
- Perkins J (1996) Botswana: fencing out the equity issue. Cattleposts and cattle ranching in the Kalahari Desert. *J Arid Environ* 33(4):503–517
- Rwamigisa PB, Birner R, Mangheni MN, Semana A (2018) How to promote institutional reforms in the agricultural sector? A case study of Uganda's National Agricultural Advisory Services (NAADS). *Dev Policy Rev* 36(5):607–627
- Shackleton S, Ziervogel G, Sallu S, Gill T, Tschakert P (2015) Why is socially-just climate change adaptation in sub-Saharan Africa so challenging? A review of barriers identified from empirical cases. *Wiley Interdiscip Rev Clim Change* 6(3):321–344
- Speranza CI, Kiteme B, Ambenje P, UrsWiesmann, Makali S (2010) Indigenous knowledge related to climate variability and change: insights from droughts in semi-arid areas of former Makueni District, Kenya. *Clim Change* 100:295–315. <https://doi.org/10.1007/s10584-009-9713-0>
- USAID (2011) Climate Change and Conflict in Uganda: The Cattle Corridor and Karamoja. CMM Discussion Paper No 3 USAID. Kampala, Uganda
- Weber KT, Horst S (2011) Desertification and livestock grazing: the roles of sedentarization, mobility and rest. *Pastoral Res Policy Pract* 1(1):19
- World Bank (2007) World Development report 2008. Agriculture for Development. World Bank. Washington DC, USA
- Wurzinger M, Ndumu D, Baumung R, Drucker A, Okeyo A, Semambo D et al (2006) Comparison of production systems and selection criteria of Ankole cattle by breeders in Burundi, Rwanda, Tanzania and Uganda. *Trop Anim Health Prod* 38(7):571–581
- Wurzinger M, Okeyo AM, Semambo D, Souml J (2009) The sedentarisation process of the Bahima in Uganda: an emic view. *Afr J Agric Res* 4(11):1154–1158
- Zziwa E, Kironchi G, Gachene C, Mugerwa S, Mpairwe D (2012) The dynamics of land use and land cover change in Nakasongola district. *J Biodivers Environ Sci* 2(5):61–73

**Open Access** This chapter is licensed under the terms of the Creative Commons Attribution 4.0 International License (<http://creativecommons.org/licenses/by/4.0/>), which permits use, sharing, adaptation, distribution and reproduction in any medium or format, as long as you give appropriate credit to the original author(s) and the source, provide a link to the Creative Commons license and indicate if changes were made.

The images or other third party material in this chapter are included in the chapter's Creative Commons license, unless indicated otherwise in a credit line to the material. If material is not included in the chapter's Creative Commons license and your intended use is not permitted by statutory regulation or exceeds the permitted use, you will need to obtain permission directly from the copyright holder.







# Rethinking Climate-Smart Agriculture Adoption for Resilience-Building Among Smallholder Farmers: Gender-Sensitive Adoption Framework

# 36

Sizwile Khoza, Dewald van Niekerk, and Livhuwani NemaKonde

## Contents

Introduction .....	678
Criticism Directed at CSA .....	680
The Concept of CSA in a DRR Context .....	681
Methodology .....	682
Findings .....	684
Ownership of Land .....	684
Participation in CSA Technology Development .....	684
CSA Options Available for Farmers .....	685
CSA Goals for Farmers .....	685
Discussion .....	686
Gender-Equitable Resilience in CSA Adoption .....	686
Enablers for CSA Adoption .....	688
Strategies to Improve CSA Adoption .....	690
Gender-Equitable Resilience Capitals .....	691
Risk Information: Generation and Access .....	692
Risk-Informed Decision-Making .....	693
Gender-Sensitive CSA Technology Development .....	693
Operationalization of the Framework .....	694
Key Lessons, Study Limitations, and Future Research Prospects for CSA .....	695
Conclusions .....	696
References .....	696

This chapter was previously published non-open access with exclusive rights reserved by the Publisher. It has been changed retrospectively to open access under a CC BY 4.0 license and the copyright holder is “The Author(s)”. For further details, please see the license information at the end of the chapter.

S. Khoza (✉) · D. van Niekerk · L. NemaKonde  
Unit for Environmental Sciences and Management, African Centre for Disaster Studies, North-West University, Potchefstroom, South Africa  
e-mail: [sizwilenk@gmail.com](mailto:sizwilenk@gmail.com); [dewaldvn@acds.co.za](mailto:dewaldvn@acds.co.za); [livhuwani.nemakonde@acds.co.za](mailto:livhuwani.nemakonde@acds.co.za)

---

**Abstract**

This study identifies the need for holistic understanding of gender-differentiated climate-smart agriculture (CSA) adoption by smallholder farmers who are at the frontline of climate-related hazards and disasters in Africa. CSA adoption is predominantly informed by a parochial linear approach to farmers' decision-making processes. Resilience-building and adaptation, which forms the second pillar of CSA and can enhance understanding of the CSA adoption nuances at farmer level, often receives less attention in adoption investigations. To appreciate CSA adoption from a resilience perspective, this study focused on resilience-building based on the interlinkage between CSA and disaster risk reduction and applied a resilience perspective in a gendered approach to CSA adoption by smallholder farmers. Through primary data collected in an exploratory sequential mixed method design, the study presents a proposed normative gender-sensitive CSA adoption framework to guide CSA implementation strategies and policies. The framework is anchored in resilience thinking, and some of its key components include gender-sensitive CSA technology development, risk-informed decision-making by heterogeneous smallholder farmers, gender-sensitive enabling factors, resilience strategies, gender equitable and equal ownership, and control of and access to resilience capitals. The proposed framework can be used to improve CSA adoption by smallholder farmers by addressing gendered vulnerability and inequality that influence low adoption.

---

**Keywords**

Climate-smart agriculture · Disaster risk reduction · Gender · Adoption · Resilience · Framework

---

**Introduction**

Climate change threatens the achievement of sustainable development, undeniably presenting complex developmental challenges in less developed regions. The impetus is to find solutions to the dilemmas that disasters related to climate change present, especially in regions such as Southern Africa, which are categorized as climate change hotspots (Müller et al. 2014). In recent agricultural seasons, Southern Africa has faced devastating and unprecedented climate change-related disasters, often resulting in Member States declaring a state of disaster. Some climate-related disasters affect only one country, such as the floods in Malawi in the 2014–2015 agricultural season that caused the country to declare a state of disaster due to floods (Murray et al. 2016). Others transcend national boundaries, for example, the El Niño–Southern Oscillation-induced drought of 2015–2016 that caused Eswatini, Lesotho, Malawi, Namibia, and Zimbabwe to declare state of drought emergency (Nhamo et al. 2019). Other examples include the fall armyworm *Spodoptera frugiperda* infestation of 2017–2018 and cyclones Idai and Kenneth in the

2018–2019 season. The result of these disasters is that the food security, poverty alleviation, and sustainable development ambitions of individual countries and the affected regions are hampered (Lipper et al. 2018). One of the chief concerns is the effect of climate-related disasters on smallholder farming, which in most developing countries is estimated to constitute at least 70% of the population, with the agriculture sector contributing at least a third of gross domestic product (Diao et al. 2010).

Consequently, current development discourse in Africa is concerned with exploring resilience-building strategies for smallholder farming households so that they may become resilient in the face of climate-related disasters (Speranza et al. 2014; Lipper et al. 2018). With each climate-related disaster, there is a growing need to change from conventional agricultural farming toward new, unfamiliar, and uncommon farming technologies perceived to contribute toward resilience-building. It is for this reason that climate-smart agriculture (CSA) has gained prominence as a possible panacea to the developmental challenges presented by climate change, specifically in relation to smallholder farming in Africa (Arslan et al. 2018). CSA recognizes that climate change amplifies developmental challenges, hence its conceptualization based on three pillars, viz., (1) improved food and agricultural productivity, (2) resilience-building and adaptation, and (3) mitigation through the reduction of greenhouse gas emissions from agricultural activities (Asfaw et al. 2015; Chandra et al. 2017a). CSA is a livelihood-oriented integration of the triple wins of sustainable intensification, resilience-building, and climate mitigation (Taylor 2018). The adoption of CSA technologies and strategies provides one option for resilience-building. Consequently, there is growing focus on adoption of CSA technologies by smallholder farmers (Kpadonou et al. 2017; Nyasimi et al. 2017), although there are still some shortcomings in the understanding of CSA adoption. This chapter seeks to offer an in-depth understanding of the tensions between gender inequality and CSA adoption and of the existing limitations to resilience-building through CSA. The research departed from a resilience perspective applied on the CSA pillar that seeks to build resilience and promote the adaptation of smallholder farmers. It was conducted in two regions sharing almost similar disaster profiles, namely, Malawi and Zambia.

Findings show that low CSA adoption can be attributed to gender disparities in ownership of resilience capitals, inadequate provision for equal participation of smallholder farmers in CSA technology development, a lack of diverse CSA options that farmers could adopt, and the failure to sustain household food security, income generation, and improved quality of life through CSA. This chapter accentuates that increasing climate risk compels an exploration of measures to address these shortcomings of CSA. Furthermore, the paper emphasizes heightened need to pursue alternative gender-sensitive pathways that may help address gender disparities. Such disparities in smallholder farming societies continue to be a barrier not only to CSA adoption but also to resilience-building in the face of climate change. In pursuit of alternative approaches to addressing barriers to CSA adoption and increasing its uptake by smallholder farmers, this chapter presents a normative gender-sensitive CSA adoption framework that can be adapted and used in developing regions, ultimately contributing to resilience-building.

## Criticism Directed at CSA

The conceptualization of CSA envisions that humanity could address some of its developmental challenges, such as the negative effects of climate change, population growth, and the corresponding increases in food demand, poverty, and sustainable development (Williams et al. 2015). Unfortunately, despite its positive attributes, CSA has also been met with some skepticism that cannot be ignored in a gendered approach to CSA adoption. The main criticism is insufficient consideration of power relations and inequalities (Chandra et al. 2017b). While Taylor (2018) considers power disparities at a global level between countries of the North and the South, this study considers these aspects at a farmer level. Further dissensions over CSA emanate from its failure to promote participation of local communities, with technologies and research dominantly unidirectional and top-down (Chandra et al. 2017a). Other scholars caution that when CSA fails to pay attention to social issues, its implementation may actually magnify preexisting social imbalances such as gender inequality (Murray et al. 2016; Collins 2017). When considered within the context of the pivotal role women play in smallholder farming, current CSA scholarship has insufficiencies when it comes to the appreciation of the gender dimensions in the CSA adoption decision-making process. Yet, for many African societies, the gender composition in the smallholder farming sector validates the relevance of gender as an investigative element.

Previous work by Khoza et al. (2019) shows that underlying gender inequality, patriarchy, and other social imbalances manifest as gender-differentiated, sociocultural, sociopsychological, and gendered vulnerability drivers that shape decisions on whether to adopt, dis-adopt, or not adopt CSA technologies. This emanates from a focus on CSA as solving the dilemma of climate change through technical fixes to increase food production. The provision of technological solutions for resilience requires consideration of their social implications, the absence of which has resulted in growing concern over the observed adoption paradox. Failure to address the underlying gender inequalities and vulnerabilities may have ramifications for resilience-building for smallholder farmers. Additionally, an existing understanding of CSA adoption is framed within a simplistic linear approach, which is insufficient when gender and resilience-building dimensions are brought into consideration. Thus, this study was conducted with the aim to explore the application of a resilience perspective to CSA to address the underlying gender inequality and gendered vulnerability in order to improve CSA adoption by diverse men and women smallholder farmers.

The shortcomings of CSA have also been linked to the issue of a conceptual misnomer, arising from a general conceptualization of CSA that includes policies, technologies, and practices at farmer, landscape, and ecosystem levels (Lipper et al. 2014). While some literature labels CSA as an already compromised concept pushing a hegemonic agenda for the developed countries (Taylor 2018), the concept has the potential to address some of the challenges African societies face with climate change. Having considered the concerns, this study situates CSA adoption assessment at a farmer level and with a deliberate focus on technologies and practices that farmers have to adopt. Some scholars highlight the need for alternative

frameworks to address the shortcomings of CSA (Taylor 2018; Glover et al. 2019). This gives currency to the application of resilience thinking in CSA adoption, and a reconnaissance of CSA that leverages on its relationship with disaster risk reduction (DRR) can help address some of the highlighted shortcomings.

## The Concept of CSA in a DRR Context

The second pillar of CSA is “resilience-building and adaptation,” which underpins the interconnectedness of CSA and DRR (FAO 2013). This relationship paves the way for the application of a DRR lens to CSA in order to explore opportunities for improving CSA adoption by smallholder farmers. The climate-related risks and disasters affecting smallholder farming as already outlined in the introduction of this chapter give credence to such an approach. Moreover, at a farmer level, the demarcations between adaptation, resilience-building, and DRR are indistinct, as farmers are more concerned with surviving each disaster event.

A DRR approach to CSA draws attention to issues of vulnerability reduction, while CSA implementation in smallholder farming provides a vehicle to deliver both risk reduction and adaptation simultaneously (FAO 2013). A DRR approach to CSA could help resolve some of the shortcomings of CSA as highlighted in the preceding section. Greater strides have been made in DRR than in CSA, for example, in terms of the appreciation of resilience-building, indigenous knowledge systems, and the application of socio-ecological system concept to understand resilience-building and community-based participation (FAO 2013; Coetzee et al. 2016). Therefore, CSA could draw from progress made in DRR this far as a way of resolving the adoption challenges. Unfortunately, there has been minimal scholarly interrogation of CSA from a DRR perspective. Yet, at a time when increased climate risk threatens to wipe out the development gains made in agriculture so far, such a consolidated approach could better cross-examine CSA adoption. Furthermore, the relationship of DRR and resilience provides basis to interrogate CSA adoption from a disaster resilience perspective.

Disaster resilience is framed as an *ability*, where a system and its units are able to anticipate, absorb, accommodate, and recover from a disturbance by bouncing back or bouncing forward timeously and efficiently (Manyena et al. 2011). The system and its units may have the ability to change without loss of basic structure and functions, or self-organize, attaining incremental capacity to learn, adapt, and change through absorptive, adaptive, or transformative capacities (Béné et al. 2016). When smallholder farmers make decisions to adopt CSA technologies and practices, that is essentially indicative of their aspirations to be resilient to climate vagaries. Resilience of a system or its units, which in this study were individual farming households in a farming system, is better appreciated by considering resilience principles. This includes maintenance of redundancy and diversity, management of intra-system connectivity, feedbacks, promotion of social learning, participation and inclusion, embracing polycentricity, and understanding that agricultural systems are complex adaptive systems (Carpenter et al. 2012; Coetzee et al. 2016). Therefore, in assessing CSA adoption challenges from a resilience perspective, we argue that these

resilience principles can be applied to assess barriers to CSA adoption and may help identify required improvements to build the resilience of farming households and communities.

Absorptive resilience is when households are able to contend with the negative effects of climate disasters through persistent coping and resistance, without any distinct changes to function or structure (Bennett et al. 2014), for example, when households cope with a drought through humanitarian interventions such as food aid distribution. Adaptive resilience is when the agricultural system or its units have the ability to learn from acquired or experiential knowledge and to make adjustments in response to disasters (Walker et al. 2004). In adaptive resilience, the aim is to make adjustments for continued functioning within a household or system. Transformative resilience refers to the capacity for change in structure and function of the system or households owing to disturbance. Transformation is more concerned with changes made in behaviors, cultural ethos, stereotypes, institutions, and policy direction (Walker et al. 2004). Thus, transformation depends on interrogation of the status quo and advocating for pragmatic changes in structure or function to be instituted. Adaptation and transformation are long-term and essential dimensions of resilience from a development standpoint. It is important to bear in mind that the three dimensions should not be pursued separately in linear fashion. It is important to harness the existing synergies among them (Béné et al. 2016).

Accordingly, for the majority at-risk rural smallholder farmers, CSA offers a pragmatic relevant conduit to pursue resilience. The assorted CSA options (see Table 1) contribute or have the potential to contribute to the three resilience dimensions, so it is worth mentioning that CSA implementation and policies should not elevate any one dimension and subordinate the others. Rather, in building on the synergistic relationships of absorption, adaptation, and transformation, CSA can help smallholder farmers and their systems become resilient.

In the context of smallholder farming in developing regions where CSA is promoted, it is key to recognize the heterogeneity of the farmers (Khoza et al. 2019).

The diversity among smallholder farmers draws attention to existing inequalities that relate to vulnerability and shape power, agency, ownership and control of resources, decision-making, and participation within farming systems (Ensor et al. 2018). This magnifies the need for resilience-building in CSA to pay attention to the skewed landscape within which CSA adoption decisions have to be made by different farmers. Ultimately, this mandates that over and above absorptive and adaptive resilience, transformation is required in CSA. This compels the interrogation of existing social imbalances that determine whether a smallholder farmer will adopt, dis-adopt, or not adopt CSA.

---

## Methodology

An exploratory sequential mixed method design (Teddlie and Tashakkori 2009) was applied in Chikwawa, Malawi, and Gwembe, Zambia, to gather empirical data at a local level where smallholder farmers interface with climate-related disasters and

**Table 1** Climate-smart agriculture options

CSA options	Examples
<i>Crop management</i>	Intercropping
	Crop rotation
	Crop diversification
	Improved seed varieties
	Value chains and marketing
	Improved postharvest storage
	Agro-processing
<i>Livestock management</i>	Fodder crops
	Feedlots
	Improved breed
	Rotational grazing
	Grassland restoration and conservation
<i>Soil and water management</i>	Basin/mechanized conservation farming
	Solar-powered irrigation
	Rehabilitation of degraded landscapes
<i>Agroforestry</i>	Woodlots
	Fruit trees
	Nitrogen-fixing trees
	Multipurpose trees
<i>Integrated food-energy systems</i>	Biogas stoves
	Energy-saving stoves
<i>Infrastructure</i>	Roads
	Housing
	Mobile network
<i>Access to climate information</i>	ICT platforms/information hubs
<i>Fisheries</i>	Aquaculture
	Capture fisheries

Adapted from FAO (2013)

where resilience-building is essential. The study was conducted between 2017 and 2019, with data collection in February and March 2018. The initial phase entailed qualitative data collection through semi-structured face-to-face interviews from purposively selected key informants at district level and focus group discussions (FGDs) at ward level. A total of 16 interviews and 6 FGDs were conducted (3 in each country: men only, women only, and mixed men and women). Thematic qualitative data analysis informed the design of an instrument used in quantitative cross-sectional data collection. In the quantitative cross-sectional survey, a total of 102 smallholder farmers were interviewed, 51 from each study site. The cross-sectional survey served to explore the generalizability of the themes established from the qualitative findings. In order to capture the perspectives and contexts of the gender dimensions in CSA adoption, the study placed emphasis on qualitative findings. This is in line with the methodological provisions of a mixed method

research design (Teddlie and Tashakkori 2009). The quantitative data was analyzed with SPSS version 26 for descriptive statistics that established the distribution and trends.

---

## Findings

### Ownership of Land

The findings revealed that in Chikwawa, the average land owned by men household heads was 1.4 ha, while for women, it was 0.7 ha. In Gwembe, 40% of women-headed households who indicated they rented land did so for CSA purposes. While men household heads generally rented land in addition to what they owned, the women rented land because they were landless. Land ownership by women in Africa is a contentious issue (Doss et al. 2015), and these findings call for renewed effort to address the issue. Land ownership influences the adoption of agricultural technologies and practices; therefore, if CSA is to contribute to resilience-building, there is a need for equal distribution of land as a starting point toward equitable resilience (Matin et al. 2018).

### Participation in CSA Technology Development

The qualitative findings established that CSA technology development occurred in a top-down manner, with smallholder farmers not engaged in technology development as they are generally considered as recipients “who receive your technology you have developed for them” (NGO respondent, Chikwawa). In both study sites, field days and demonstration plots were identified as opportunities for farmer participation in technology development. However, respondents acknowledged that even these events were top-down as they mainly showcased technologies that had been developed *for* the farmer, and technologies developed *with* the farmers’ involvement were rare, if any. Currently, no mixed approach to CSA technology development that comprises technologies developed *for* and *with* the farmers is being considered. This may be due to the perception that farmers are technology recipients, as reflected by some interviewees: “they cannot contribute anything in technology development... what do farmers know that they can contribute in CSA?” (Government Department Respondent, Gwembe).

These sentiments were corroborated by quantitative findings that established that there was minimal participation among farmers in technology development irrespective of gender. In Chikwawa, 25% of the households, with over 70% of these being male household heads, stated that they had been involved in meetings when conservation farming and irrigation schemes were first brought to their communities. In Gwembe, 11% of the farmers acknowledged participation in similar meetings. At both study sites, those who participated in meetings went on to become adopters as they benefited from the respective CSA projects.



However, this is insufficient as participation should also include problem identification, evaluation of options, and eventual selection of technologies that farmers know will address their problems. This would leave room for the consideration of indigenous knowledge systems, which can also be considered as alternatives to solve the problems farmers face. For example, in Chikwawa, farmers shared how they used a fish broth to control the fall armyworm before pesticides were available. Scientific research could be incorporated to explore how indigenous knowledge can be harnessed in CSA.

## **CSA Options Available for Farmers**

The qualitative findings established that conservation farming was the major form of CSA that farmers have adopted, and confirmation from quantitative findings revealed that 100% of farmers practicing CSA at both sites stated that they used improved seed varieties (ISVs) and soil moisture conservation techniques. At both study sites, less than 40% of sampled households were engaged in more than one form of CSA. In Chikwawa, other forms of CSA included small-scale irrigation schemes, while in Gwembe, a new aquaculture project was at inception stage at the time of data collection. In Gwembe, less than 20% of interviewed farmers had also been previously involved in improved livestock breed projects. However, the qualitative findings showed that there were concerns that conservation farming alone was insufficient in addressing farmers' needs as explained by practitioners:

...we know that crop production is always vulnerable, we also need to bring in livestock for the farmers, to help them when crops fail...especially goats which they can sell when crops fail. (Respondent from Government Department, Chikwawa)

The quantitative findings showed that livestock ownership differed between male and female heads of households. At both sites, married men owned the most cattle, with average cattle ownership in Chikwawa being two heads, while in Gwembe, it was eight. More female household heads owned cattle in Gwembe than in Chikwawa, 16% and 7%, respectively. When these trends are viewed from an intersectionality perspective, intersection of gender with education and wealth status can be noted as the women who owned cattle in Gwembe were predominantly retired professionals who were categorized as better-off in the community wealth rankings.

## **CSA Goals for Farmers**

In Chikwawa, qualitative findings established that the intended CSA outcomes of improved agricultural productivity and resilience-building were not being achieved by means of the CSA options available to farmers. Evidence of these shortcomings of CSA was linked to humanitarian food assistance. Qualitative findings indicated that there was no major difference in terms of food security between CSA farmers

and those who were not involved in any form of CSA because “we see it when it comes to food aid, they all need assistance because they will be all food insecure” (Respondent from Government Department, Chikwawa). More concerning were sentiments from non-adopters who indicated a lack of motivation to adopt available CSA options because “we are all the same, CSA does not make them any better than us” (Discussants in mixed gender FGD, Chikwawa). These findings were confirmed by the quantitative survey where 100% of farmers who adopted conservation farming also reiterated that they benefited from food aid each year because of low crop yields. Farmers using ISVs raised concerns about their susceptibility to the fall armyworm, claiming that their traditional open-pollinated varieties (OPVs) were better resistant.

In Gwembe, a different scenario emerged when assessing whether CSA options were able to contribute to food security and resilience-building. Qualitative findings established that while yields increased through conservation farming, there were postharvest crop losses as farmers could not sell their surplus anywhere. Quantitative findings confirmed these sentiments as 100% of the farmers who were practicing conservation farming techniques were utilizing less than half of their arable land for CSA to “avoid high yields that they would still lose through spoilage,” as farmers concurred during household survey in Gwembe.

---

## Discussion

### Gender-Equitable Resilience in CSA Adoption

The findings presented in this chapter show that men and women farmers may not be realizing benefits of the CSA activities they are involved in. Findings further show that currently, CSA is not contributing toward the resilience of farmers as they are still prone to food insecurity, often relying on food aid to see them through to the next season. This creates a dependency syndrome and demotivation farmers in CSA adoption. Moreover, dominance of conservation farming leaves farmers vulnerable to climate hazards that have a negative effect on crop production. Findings illuminate the insufficiencies of current CSA and gaps that continue to hinder CSA adoption, especially among women farmers. This chapter accentuates that a resilience framing of CSA leaves room for broader consideration of the decision-making context within which smallholder farmers live. On that basis, a normative gender-sensitive CSA adoption model (Fig. 1) is proposed.

The aim of the framework is to provide a normative approach to improve CSA adoption, especially by diverse women smallholder farmers in developing regions, considering their central role in farming activities. The framework is conceptualized from a resilience viewpoint, enabling a more holistic approach to the issues that may enhance decision-making by different groups of farmers, especially diverse women smallholder farmers. There is a need for gender transformation at various CSA implementation levels, starting at household level up to national and global levels. Transformation requires various strategies and enablers to be put in place to create

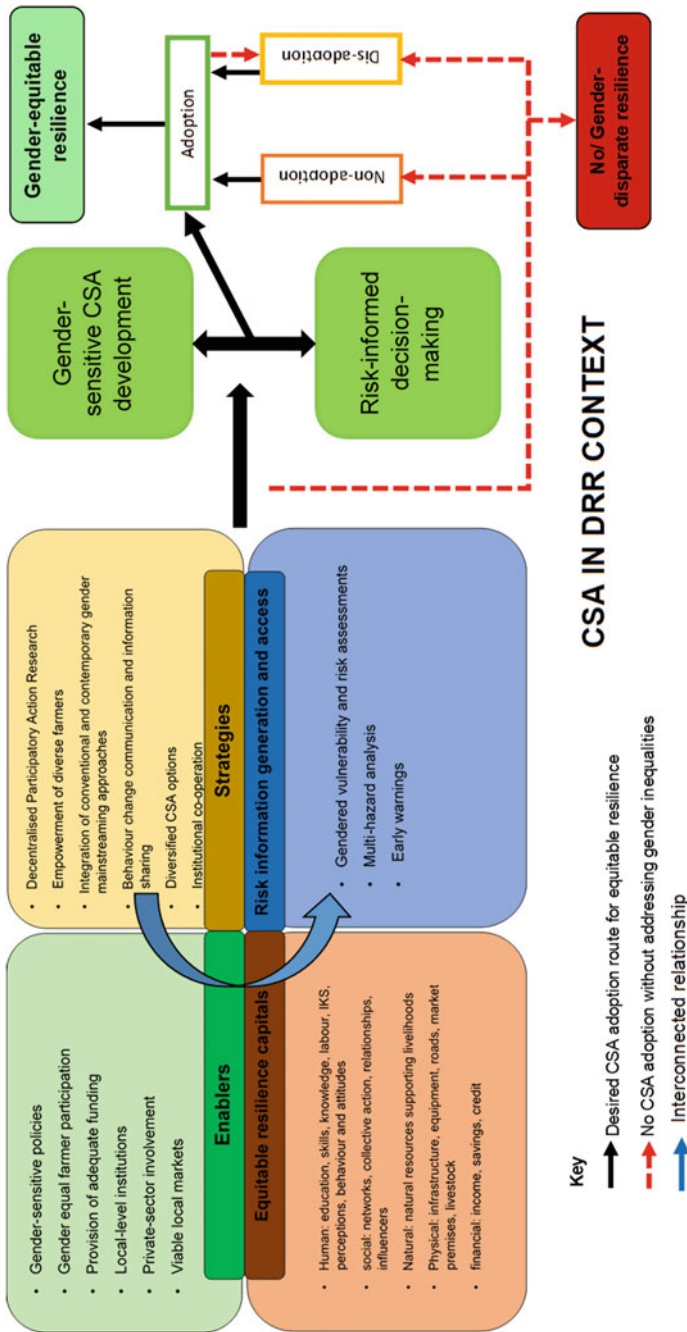


Fig. 1 Proposed gender-sensitive CSA adoption framework

equality and address gendered vulnerability, which should potentially result in improved CSA adoption at household level. The gender-sensitive CSA adoption framework comprises various interconnected components that should be used from a gender perspective throughout, aimed at transformation toward more egalitarian-resilient societies. In the proposed framework, the desired adoption route likely to help achieve gender-equitable resilience is illustrated with black arrows, and the undesired route likely to result if gender disparities are not addressed is shown with red dotted arrows. The blue curved arrow shows that the enablers, strategies, gender equality, and risk information are all interconnected, interacting to inform gender-sensitive technology development and risk-informed decision-making. The framework components are discussed in the following subsections.

## **Enablers for CSA Adoption**

### **Gender-Sensitive Policies**

The findings of this study show that there are preexisting gender inequalities at household level which may be perpetuated by gender-blind CSA implementation. This chapter suggests that an improvement in CSA adoption by women farmers would require gender-sensitive policies to ensure that issues of gender inequality are addressed to achieve gender parity. This requires a holistic assessment of CSA that will consider implementation strategies and resilience capitals, not just limited to the technological benefits of CSA. There is need for policies directly or indirectly linked to CSA to be assessed for their implications on different genders. This should include land tenure systems, marriage and property inheritance laws, technology development, as well as economic empowerment, which all affect CSA adoption decisions (Doss et al. 2015; Khoza et al. 2019).

### **Gender-Equal Farmer Participation**

CSA presents various opportunities where farmers should be engaged for active participation in CSA technology development. However, study findings showed that currently, farmers' participation in CSA is mainly as recipients of already developed technologies and CSA information. CSA is characterized by top-down approaches which may fail to pay attention to critical gender issues that hinder adoption. This study reiterates the need for CSA implementation to ensure equal participation of farmers in technology development and identification of CSA options to adequately meet the resilience needs of diverse farmer categories. There should also be gender-equal participation in the co-creation of knowledge through research in gendered risk assessments, vulnerability assessments, and multi-hazard analysis. Gender-equal participation of farmers will likely assist with the identification of gender-differentiated barriers of CSA adoption and opportunities that can be harnessed to improve adoption across different genders.

When smallholder farmers are given equal opportunities to participate in various aspects of CSA, this is likely to also bring to the fore critical contextual gender issues

and to facilitate transformation. Gender-equal participation may potentially enable bottom-up engagement in CSA, where farmers can also contribute their knowledge and experiences. This is especially important when considering the role of indigenous knowledge systems in CSA. Ultimately, equal participation of farmers allows CSA to engage with their various realities, ensuring farmers have a voice in the design and ownership of CSA projects and technologies. When farmers are given the space to participate in various components of CSA, not just as recipients, they are more likely to adopt CSA. This will also enhance sustainability of CSA in communities.

### **Provision of Adequate Funding**

There is no doubt that technological requirements of CSA are likely to be costly and beyond the reach of many individual farming households. For instance, capital investment for some CSA options, such as irrigation schemes and aquaculture, may be costly. This means that at a higher national and global scale, there is a need to improve funding for CSA projects. This can be achieved through multiple funding streams. For example, at a national level, countries should fulfil commitments of the Malabo Declaration that states that African governments should allocate 10% of their public spending to agriculture (AU 2014). Other funding sources could be explored through other government sectors. For instance, on the basis of its relationship with DRR, disaster risk management (DRM) departments could also provide part of the funding required for CSA. Similarly, at a global level, multiple sources may be explored apart from specific CSA projects, such as resilience-building, climate change adaptation, or DRR funds.

Importantly, CSA funding should ensure that funds provided address the resource needs of local-level institutions, such as the provision of vehicles, information and communication technology equipment, and recruitment of more extension agents. This will likely improve quality of gender-specific contact extension services provided to the farmers. This may also compel strategic direction toward the integration of local-level institutions.

### **Local-Level Institutions**

Strong operational relationships among local government and nongovernmental institutions are required to facilitate gender-sensitive CSA adoption. According to Carpenter et al. (2012), polycentricity is key to resilience, often helping to promote connectivity within systems and facilitating learning. This is key in CSA where diverse institutions need to work together. These institutions are the first-level responders to different hazards affecting smallholder farmers; hence, their cooperation is necessary to improve adoption of diverse CSA options. Local-level institutional cooperation and collective action remain essential in the provision of extension services, information dissemination, and facilitation of gender transformation in communities. Ultimately, a polycentric approach enhances the delivery of CSA with precision and efficiency to meet gender-specific farmer resilience needs.

### **Private Sector and Viable Markets**

The findings reveal that one major drawback of CSA adoption by both men and women farmers is the lack of improved quality of life as a result. This was connected to a lack of economic opportunities, resulting in farmers failing to earn meaningful income from the sale of surplus produce. This chapter recommends that innovative strategies be implemented to involve the private sector in CSA to ensure win-win scenarios for farmers and business. CSA adoption is negatively affected by unviable local markets, and an enabling environment for CSA adoption should consider creation of viable local markets where farmers can buy and sell CSA inputs and outputs. This may help create a thriving local economy and increase the income earned from CSA to meet household needs.

### **Strategies to Improve CSA Adoption**

#### **Decentralized Participatory Action Research**

The gender disparities identified in the study magnify the need for CSA adoption to be informed by participatory action research (PAR), which can be achieved with an enabling environment for gender-equal participation of smallholder farmers. PAR may facilitate engagement with farmers, giving them a platform to share their experiences in gender issues that demotivate them from adopting CSA or drive them to discontinue CSA. Furthermore, PAR should be decentralized, allowing research to be conducted at the local epicenter of climate disasters. The strength of PAR in driving CSA adoption is the recognition of farmers as both sources and consumers of knowledge, with their involvement in research tapping into local knowledge, perspectives, and realities. At the same time, they are able to use the information from PAR to inform their CSA adoption decisions. Decentralization of PAR to local level should be gender-sensitive, identifying best ways to examine challenges and opportunities for specific groups of farmers in CSA. Farmer participation will illuminate sociopsychological behaviors, attitudes, and perceptions of diverse groups, ensuring that precise and complete information equips farmers' decision-making. PAR is also essential in creating a platform for behavior change communication and information sharing.

#### **Diversity of Livelihoods and CSA Options**

Considering CSA from a resilience perspective magnifies the need for CSA to move beyond dominance of conservation farming as revealed in this study. If CSA is to contribute to resilience of diverse smallholder farmers, then there is a need to provide diversified CSA options in addition to conservation farming. Diversified CSA options ensure redundancy so that in the face of a climate-related disaster affecting one component of the farming systems, farmers have other alternatives to rely on (Carpenter et al. 2012). The dominant focus on conservation farming could help explain protracted food insecurity and vulnerability, with farmers often relying on food aid assistance. Therefore, a resilience lens in CSA advocates for transformation

toward consideration of other livelihoods and CSA options. This may include income generation through sale of improved livestock breeds, honey from apiculture, or fish from aquaculture, among others. Diversity and redundancy should improve the resilience of farmers, and gender should be considered to assess which CSA options would be relevant to each category of farmers.

### **Empowerment of Diverse Women Farmers**

In view of the study findings, this chapter accentuates the need for the empowerment of communities in general and women in particular to equip them to be able to articulate their resilience needs and to demand more space to participate in different aspects of CSA. The heterogeneity of women smallholder farmers is suggestive of their corresponding diverse resilience needs. This is essential when considering issues of economic empowerment in CSA. CSA adopters have not been able to derive tangible economic benefits, yet this is one of the goals of CSA. Empowerment of farmers means they will participate in technology development, contributing toward defining relevant CSA options they need, and they will participate in decision-making at various levels from intra-household level going up.

Empowerment in CSA should ensure that women farmers can share their experiences, practice autonomy and agency, and be able to collectively come together to tackle structural bottlenecks affecting their adoption decisions. However, this requires a transformation from traditional gender mainstreaming approaches that have shaped empowerment efforts in the past, toward an integrated approach that also considers contemporary approaches such as intersectionality, African feminisms, and positive masculinity (Arndt 2002; Davis 2008). Studies have shown insufficiencies of traditional gender mainstreaming approaches in addressing gender inequality and patriarchy in agriculture (Khoza et al. 2019). The integration of traditional and contemporary approaches may compensate for the weaknesses of each approach applied on its own. Empowerment should address practical gender needs while also ensuring that attention is paid to structural gender issues that may hinder especially women household heads from adoption of CSA. Empowerment should also pave way for participation and inclusion of farmers, especially women, in the various aspects of CSA as explained in earlier sections. This remains an essential vehicle of transformation.

### **Gender-Equitable Resilience Capitals**

Based on the study findings, this chapter highlights that a resilience framing of CSA adoption compels consideration of gender inequality and gendered vulnerability with regard to access to and control and ownership of resilience capitals (Mayunga 2007). The gender constructions that determine who owns, has access, and controls resilience capitals should be assessed in CSA as they shape farmers' adoption decisions. In order to achieve resilience-building through CSA, there is a need for deliberate strategies aimed at establishing gender equality and equity in the ownership, control of, and access to social, natural, physical, financial, and human

resilience capitals. This will require CSA to engage with disparities and to improve especially the ownership of resilience capitals such as farming equipment, livestock, land, and finance by women farmers. This will not only enable them to cope with climatic disturbances but will also ensure they are equipped to build back better or bounce forward from each disturbance. Paying attention to resilience capitals also helps illuminate key vulnerability issues that dispose farmers to either dis-adoption or non-adoption of CSA. Creating gender equality and equity in resilience capital ownership will require innovation in tackling the socioculturally entrenched patriarchal systems and women's subordination, and contemporary gender mainstreaming approaches may be useful in this regard.

While addressing identified gender inequality issues may not be the primary mandate of agricultural departments, a resilience framing emphasizes polycentricity and collective action. Other development actors need to be involved in CSA, such as gender, DRM and community development departments, NGOs, women's rights activists, and local leaders. These structures already exist at a local level, although agriculture departments may need to lead the integration to ensure that the expertise of various groups is channeled toward addressing inequality and vulnerability in pursuit of resilience.

### **Risk Information: Generation and Access**

Any attempt to improve CSA adoption requires strategies to ensure supply of adequate information to aid farmers during decision-making. Collective action, participation, and inclusion are key to the generation of risk information. Processes to generate risk information are undertaken by governments, NGOs, and donor agencies in many countries. These are usually in the form of vulnerability and risk assessments, as well as hazard analysis. However, there is a need to move beyond simple gender-disaggregated data generated in these processes to critically engage with the gender implications of collected data in terms of resilience-building. Risk information is not only useful to technocrats and practitioners, but farmers should also have access to the information for decision-making. Knowledge is required to make informed decisions. Across different gender groups, its creation and acquisition is important in decision-making. The proposed framework advocates for the involvement of farmers in knowledge co-creation, which will harness valuable indigenous knowledge, especially with regard to climate hazards and early warnings. This means attention should be paid to access to gender-sensitive risk communication. Gender-sensitive risk information is also requisite in development of gender-sensitive CSA technologies.

A systemic approach helps appreciate that CSA adoption decisions are not only based on technological benefits of CSA options. Farmers consider other risks that affect their resilience capitals negatively or positively within the wider system context. For instance, for many communities, disease epidemics such as HIV/AIDS remain a health risk that threatens agricultural labor provision in households. Therefore, any adoption improvement strategy should engage farmers to identify



what other risks they face in their contexts, and this may be achieved through gender vulnerability and risk assessments, as well as multi-hazard analyses that should endeavor to obtain in-depth qualitative perspectives on systemic risks.

## **Risk-Informed Decision-Making**

Adoption decisions of men and women smallholder farmers are influenced by various factors depending on their gender roles (Khoza et al. 2019). Importantly, decision-making for men and women household heads should be viewed within the multifaceted context in which decisions are made and have to be risk-informed. There is a need to acknowledge different factors and drivers that shape decision-making for different genders. A resilience framing of CSA accommodates risk-informed decision-making (RIDM) even at smallholder farmer level (Weichselgartner and Pigeon 2015). RIDM acknowledges that decision-making is not in simple linear fashion as traditionally understood. It is a more comprehensive analytical approach that interrogates and seeks to understand complex interactions between people, risks, hazards, and systems. Risk-informed decisions pay attention to qualitative information from gender-differentiated risk assessments (Gardoni et al. 2016), narratives, and realities that shape decisions by different farmers. However, Apostolakis (2004) caution against the exclusive use of risk assessments to inform decisions, necessitating a more consolidated approach where gender vulnerability assessments and multi-hazard analyses can also feed into decision-making.

## **Gender-Sensitive CSA Technology Development**

Findings of this study showed that smallholder farmers, irrespective of gender, were not directly involved in the development of CSA technologies. Rather, technology development was a top-down process where farmers were viewed as recipients. However, this chapter argues that if CSA adoption is to be improved, there is a need for farmers to participate in technology development. CSA technology development should be two-way, with provision for consideration and development of local farmer innovations for further scaling up. Development and dissemination of CSA technology should be participatory to generate and manage perspectives that may determine adoption decisions made especially by the women farmers. CSA technology development should therefore be informed by the gender analyses that recognize gender roles and interactions with technology in relation to culture, behaviors, attitudes, and social influences (Ngigi et al. 2018; Khoza et al. 2019). Development of CSA technology should appreciate and address any underlying disparate distribution of resilience capitals. Failure to consider these underlying factors and corresponding strategies to address them may manifest as low adoption of CSA by women farmers.

Additionally, through gender analyses, CSA technology development can consider existing and projected changes in gender roles. CSA technology may seek to

improve current gender roles, or transform them, depending on identified inequalities and farmer needs (Nyasimi and Huyer 2017), where technologies can be developed to help bridge the gender productivity gap and contribute to equitable resilience across the heterogeneity of smallholder farmers. For instance, women in men-headed households and women who were household heads lamented labor demands of basin conservation farming which they felt increased their workload, while they have other reproductive and community roles too. Moreover, caution should be exercised to ensure that CSA does not reinforce gender stereotypes, for instance, when CSA projects target women only for energy-saving stove distribution.

Critical to gender-sensitive technology development is the cost of CSA technologies. Women who are already less economically empowered than men are less likely to be able to afford costly new CSA technologies. CSA focus should also be on women's economic empowerment. Ultimately, rural women need appropriate CSA technologies that can transform their contexts and realities where necessary, helping them to become more resilient. This can be achieved by engaging the diverse groups of women to establish their practical and structural gender needs. Gender-sensitive CSA technology development should be as pragmatic and transformative as possible in pursuit of resilience.

---

## **Operationalization of the Framework**

This chapter suggests that utilitarian value of the framework lies in its ability to identify and confront issues of inequality and social disparities in a broader context, which may pave way for decision-making that favors CSA adoption by smallholder farmers. Operationalization of this framework should start at a district level and bring together communities and experts from diverse disciplines such as agriculture, DRM, climate change, gender, community development, local leaders, businesses, weather services, research institutions, and NGOs. Most of these disciplines are already represented at district level, although there is a need to transition toward collective integrated operations. The agriculture department may maintain the leadership and coordinating mandate, ensuring representation and multidirectional participatory engagement, communication, and information dissemination. The use of the framework can then feed into large-scale administrative processes at the provincial and national levels. Some components of the framework are already addressed by ongoing activities, such as vulnerability assessments and hazard and risk assessments. However, a gender lens should be applied in these processes, which should include smallholder farmers in their diversity, and findings from assessments should be used to inform all DRR components, not just for response through humanitarian food assistance.

The proposed framework is worth exploring as it derives value from the participatory nature of its formulation and has a strong focus on social dimensions in CSA adoption. As such, it addresses some of the gaps in current appreciation of CSA adoption, which seems to elevate the technological merits of CSA at the expense of

the equally important social dimensions. This framework's ingenuity also lies in that it speaks to the insufficiencies of a linear approach to CSA. Challenges may arise in that the framework was developed independent of any existing CSA project, which means that its uptake by different institutions is not guaranteed. Nevertheless, it does present a normative approach to improving CSA adoption so that men and women smallholder farmers can be enabled to "build back better equally, leaving no-one behind," which should form the core of resilience and sustainable livelihood outcomes in Africa.

### **Key Lessons, Study Limitations, and Future Research Prospects for CSA**

Several key lessons can be drawn from this study that applied a resilience framing to the interrogation of gender dimensions in CSA adoption. Firstly, at local level where loss and damage from each disaster event worsen food insecurity and poverty, there is an amplified urgency for gender-equitable resilience-building through CSA. This compels improvement of CSA adoption by at-risk smallholder farmers. Drawing on resilience principles may give strategy direction in CSA implementation at the local level. Resilience principles such as the maintenance of redundancy and diversity, management of intra-system connectivity, feedbacks, promotion of social learning, participation and inclusion, embracing polycentricity, and understanding that agricultural systems are complex adaptive systems all play an essential role in pursuit of gender-equitable resilience in CSA.

Secondly, there remains need to address gender inequality as it stands in the way of CSA adoption and inhibits the successful pursuit of resilience. Areas of focus should include the promotion of active and equal participation of smallholder farmers, especially vulnerable, at-risk women in CSA technology development. CSA technologies should not merely be developed *for* the smallholder farmers, but *with* them, creating space for consideration of their innovations and indigenous knowledge systems to suit their gender-specific resilience needs.

Lastly, it is essential to shift from risk-based decision-making toward risk-informed decision-making, starting at household level right up to institutional level where CSA support is provided. This is dependent on an appreciation of the fact that CSA adoption decision-making is not linear and only based on the technological benefits of CSA in the face of climate change, but rather occurs within a multifaceted decision-making context, which may differ along gender lines.

Further studies on CSA can adapt and replicate the study methodology in similar developmental contexts and disaster profiles. This study did not test the applicability of the proposed gender-sensitive CSA adoption framework. Future studies can test the applicability of the proposed framework in any of the Southern African countries or in other developing regions. The key is sensitivity to site-specific contexts on issues of gender, inequality, power, and agency. CSA adoption itself is a difficult variable to assess by means of a cross-sectional survey. Longitudinal studies can be considered in future research.

## Conclusions

The assessment of the gender dimensions of CSA adoption by smallholder farmers anchored in resilience thinking enriches understanding of the inherent challenges specifically faced by women farmers. The study highlights several factors that drive gender-differentiated vulnerability and contribute to low CSA adoption by at-risk women farmers. These factors include gender disparities in ownership of resilience capitals, limited participation of farmers in CSA technology development, narrow CSA options that can be adopted by farmers, and the limited tangible benefits realized from CSA. There is a need to improve the adoption of CSA by diverse smallholder farmers and to meet their gender-specific resilience requirements in the face of climate-related disasters. This can be achieved through the creation of an enabling environment and implementation of strategies that can facilitate gender-sensitive CSA technology development and the equal participation of smallholder farmers. The farmers should be assisted to make risk-informed decisions by improving generation and access to risk information through participatory action research. Gender equity and equality in the ownership of resilience capitals can contribute to gender-equitable resilience in smallholder farming. In conclusion, this study reiterates the importance of a gendered approach to CSA to improve adoption by smallholder farmers who directly interface with inclement climate hazards.

## References

- African Union (AU) (2014) Implementation strategy and roadmap to achieve the 2025 vision on CAADP. African Union, Addis Ababa
- Apostolakis GE (2004) How useful is quantitative risk assessment? *Risk Anal* 24(3):515–520
- Arndt S (2002) Perspectives on African feminism: defining and classifying African-feminist literatures. *Agenda* 17(54):31–44
- Arslan A, Asfaw S, Cavatassi R, Lipper L, McCarthy N, Kokwe M, Phiri G (2018) Diversification as part of a CSA strategy: the cases of Zambia and Malawi. In: Lipper L, McCarthy N, Zilberman D, Asfaw S Branca G (eds) *Climate smart agriculture: building resilience to climate change*. Springer, Cham
- Asfaw S, Bishop-Sambrook C, Diei Y, Firmian I, Henninger N, Heumesser C, Huyer S, Kristjanson P, Lefter C, Lehel S (2015) Gender in climate-smart agriculture: module 18 for gender in agriculture sourcebook. World Bank Group, Washington, DC
- Béné C, Headey D, Haddad L, von Grebmer K (2016) Is resilience a useful concept in the context of food security and nutrition programmes? Some conceptual and practical considerations. *Food Sec* 8(1):123–138
- Bennett E, Carpenter S, Gordon L, Ramankutty N, Balvanera P, Campbell B, Cramer W, Foley J, Folke C, Karlberg L (2014) Toward a more resilient agriculture. *Solutions* 5(5):65–75
- Carpenter S, Arrow K, Barrett S, Biggs R, Brock W, Crépin A-S, Engström G, Folke C, Hughes T, Kautsky N (2012) General resilience to cope with extreme events. *Sustainability* 4(12):3248–3259
- Chandra A, McNamara KE, Dargusch P (2017a) Climate-smart agriculture: perspectives and framings. *Clim Pol* 18(4):1–16
- Chandra A, McNamara KE, Dargusch P (2017b) The relevance of political ecology perspectives for smallholder climate-smart agriculture: a review. *J Polit Ecol* 24(1):821–842
- Coetzee C, Van Niekerk D, Raju E (2016) Disaster resilience and complex adaptive systems theory: finding common grounds for risk reduction. *Disaster Prev Manag* 25(2):196–211

- Collins A (2017) Saying all the right things? Gendered discourse in climate-smart agriculture. *J Peasant Stud* 45(1):1–17
- Davis K (2008) Intersectionality as buzzword: a sociology of science perspective on what makes a feminist theory successful. *Fem Theory* 9(1):67–85
- Diao X, Hazell P, Thurlow J (2010) The role of agriculture in African development. *World Dev* 38(10):1375–1383
- Doss C, Kovarik C, Peterman A, Quisumbing A, van den Bold M (2015) Gender inequalities in ownership and control of land in Africa: myth and reality. *Agric Econ* 46(3):403–434
- Ensor J, Forrester J, Matin N (2018) Bringing rights into resilience: revealing complexities of climate risks and social conflict. *Disasters* 42(2):287–305
- Food and Agriculture Organisation (FAO) (2013) Climate-smart agriculture sourcebook. FAO, Rome
- Gardoni P, Murphy C, Rowell A (2016) Risk analysis of natural hazards: interdisciplinary challenges and integrated solutions: risk analysis of natural hazards. Springer, Cham
- Glover D, Sumberg J, Ton G, Andersson J, Badstue L (2019) Rethinking technological change in smallholder agriculture. *Outlook Agric* 48(3):169–180
- Khoza S, Van Niekerk D, Nemaconde LD (2019) Understanding gender dimensions of climate-smart agriculture adoption in disaster-prone smallholder farming communities in Malawi and Zambia. *Disaster Prev Manag* 28(5):530–547
- Kpadonou RAB, Owiyo T, Barbier B, Denton F, Rutabingwa F, Kiema A (2017) Advancing climate-smart-agriculture in developing drylands: joint analysis of the adoption of multiple on-farm soil and water conservation technologies in West African Sahel. *Land Use Policy* 61:196–207
- Lipper L, Thornton P, Campbell BM, Baedeker T, Braimoh A, Bwalya M, Caron P, Cattaneo A, Garrity D, Henry K (2014) Climate-smart agriculture for food security. *Nat Clim Chang* 4(12):1068–1072
- Lipper L, McCarthy N, Zilberman D, Asfaw S, Branca G (2018) Climate smart agriculture: building resilience to climate change. Springer, Cham
- Manyena B, O'Brien G, O'Keefe P, Rose J (2011) Disaster resilience: a bounce back or bounce forward ability? *Local Environ* 16(5):417–424
- Matin N, Forrester J, Ensor J (2018) What is equitable resilience? *World Dev* 109(9):197–205
- Mayunga JS (2007) Understanding and applying the concept of community disaster resilience: a capital-based approach. In: Summer academy for social vulnerability and resilience building, Munich
- Müller C, Waha K, Bondeau A, Heinke J (2014) Hotspots of climate change impacts in sub-Saharan Africa and implications for adaptation and development. *Glob Chang Biol* 20(8):2505–2517
- Murray U, Gebremedhin Z, Brychkova G, Spillane C (2016) Smallholder-farmers and climate smart agriculture: technology and labor-productivity constraints amongst women smallholders in Malawi. *Gend Technol Dev* 20(2):117–148
- Ngigi MW, Müller U, Birner R (2018) Farmers' intrinsic values for adopting climate-smart practices in Kenya: empirical evidence from a means-end chain analysis. *Clim Dev* 10(7):614–624
- Nhamo L, Mabhaudhi T, Modi A (2019) Preparedness or repeated short-term relief aid? Building drought resilience through early warning in Southern Africa. *Water SA* 45(1):75–85
- Nyasimi M, Huyer S (2017) Closing the gender gap in agriculture under climate change. *Agric Dev* 5(30):37–40
- Nyasimi M, Kimeli P, Sayula G, Radeny M, Kinyangi J, Mungai C (2017) Adoption and dissemination pathways for climate-smart agriculture technologies and practices for climate-resilient livelihoods in Lushoto, Northeast Tanzania. *Climate* 5(3):1–22
- Speranza CI, Wiesmann U, Rist S (2014) An indicator framework for assessing livelihood resilience in the context of social–ecological dynamics. *Glob Environ Chang* 28(9):109–119
- Taylor M (2018) Climate-smart agriculture: what is it good for? *J Peasant Stud* 45(1):89–107
- Teddlie C, Tashakkori A (2009) Foundations of mixed methods research: integrating quantitative and qualitative approaches in the social and behavioral sciences. Sage, Thousand Oaks

- Walker B, Holling CS, Carpenter S, Kinzig A (2004) Resilience, adaptability and transformability in social–ecological systems. *Ecol Soc* 9(2):1–9
- Weichselgartner J, Pigeon P (2015) The role of knowledge in disaster risk reduction. *Int J Disaster Risk Sci* 6(2):107–116
- Williams TO, Mul ML, Cofie OO, Kinyangi J, Zougmore RB, Wamukoya G, Nyasimi M, Mapfumo P, Speranza CI, Amwata D (2015) Climate smart agriculture in the african context. In: *Feeding Africa: an action plan for African agricultural transformation*. African Development Bank, Dakar

**Open Access** This chapter is licensed under the terms of the Creative Commons Attribution 4.0 International License (<http://creativecommons.org/licenses/by/4.0/>), which permits use, sharing, adaptation, distribution and reproduction in any medium or format, as long as you give appropriate credit to the original author(s) and the source, provide a link to the Creative Commons license and indicate if changes were made.

The images or other third party material in this chapter are included in the chapter's Creative Commons license, unless indicated otherwise in a credit line to the material. If material is not included in the chapter's Creative Commons license and your intended use is not permitted by statutory regulation or exceeds the permitted use, you will need to obtain permission directly from the copyright holder.





# Rainfall Variability and Adaptation of Tomatoes Farmers in Santa: Northwest Region of Cameroon

# 37

Majoumo Christelle Malyse

## Contents

Introduction .....	700
Location of the Study and Research Methodology .....	702
Location of the Study Area .....	702
Methodology .....	702
Conclusion and Future Prospects .....	709
Future Prospects .....	710
References .....	710

## Abstract

The Santa agrarian basin being one of the main market gardening basins in Cameroon and one of the producers of tomatoes in the country is vulnerable to the impact of rainfall variability. The spatiotemporal variability of rainfall through the annual, monthly, and daily fluctuations has greatly affected the market gardening sector in general and tomatoes production in particular. Thus, given rise to the research topic “Rainfall variability and adaptation of tomatoes farmers in Santa North west region of Cameroon,” its principal objective is to contribute to better understanding of the recent changes occurring in tomatoes production and productivity in Santa. To attain this objective, a principal hypothesis was formulated that rainfall variability instead of unnatural conditions or human constraints justifies changes observed in tomatoes production in Santa and resulting adaptation strategies developed by peasants and stakeholders.

This chapter was previously published non-open access with exclusive rights reserved by the Publisher. It has been changed retrospectively to open access under a CC BY 4.0 license and the copyright holder is “The Author(s)”. For further details, please see the license information at the end of the chapter.

M. C. Malyse (✉)

Department of Geography, University of Dschang, Dschang, Cameroon

e-mail: [majounachristelle@gmail.com](mailto:majounachristelle@gmail.com)

© The Author(s) 2021

W. Leal Filho et al. (eds.), *African Handbook of Climate Change Adaptation*,  
[https://doi.org/10.1007/978-3-030-45106-6\\_138](https://doi.org/10.1007/978-3-030-45106-6_138)

699

Our study came out with several findings, among which includes rainfall events in Santa fluctuate in time and in space with reduction in the number of rainy day and increase in the intensity of rainfall events causing soil erosion, infertility, and frequent crop diseases, insects, and pests. Extreme events such as drought and flooding have equally become frequent in the area especially during the different cycles of tomatoes production disrupting the agricultural calendar and causing crop failure and decrease in yields with Pearson's correlation of 0.017. This positive value shows that there is a relationship between annual rainfall and tomatoes output in Santa. Tomatoes farmers in Santa are struggling to adapt locally to this situations, but their efforts are still limited especially due to their low level of education and poverty. Finally, it was seen that the output of tomatoes over the years in Santa has a strong correlation with rainfall. Based on the findings of this study, the government is called upon to assist farmers in their adaptation options.

---

**Keywords**

Rainfall variability · Tomatoes production · Extreme events · Santa agrarian basin · Market gardening

---

**Introduction**

The change in global climate system is now undeniable, and it is human-induced as it has been concluded to a large extent by scientists during the past decade (IPCC 2007). Climate variability in general and rainfall variability in particular are very important environmental problems affecting mankind today with the highland areas being very sensitive to the change in rainfall pattern and its related impacts. Tsalefac (1999) in his work on climate variability in the western highlands of Cameroon brought out some aspects. He studied the relationship that exists between climate variability, land-use pattern, and the economic crisis that brings into question the sustainability of land use in the region. As such, this work explores the state of rainfall variability in Santa and some of the adaptation options adopted by tomatoes farmers in Santa. It's aim is to elucidate how changing rainfall pattern in space and in time as well as an increase in extreme weather events which includes dry spells, torrential rains, flooding, and droughts, which has greatly affected tomatoes yields, incidence of weeds, insects, pest and diseases, the economic cost of tomatoes production and how farmers are struggling to adapt to these changes?. This work analyzes tomatoes yields with production cost from 2001 to 2011 with efforts to understand how they have varied with the current rainfall changes. It focuses on extreme weather events on tomatoes production in Santa using examples from recent past such as severe drought of 1999 and 2004 that greatly disrupted the agricultural calendar. Finally, with the current rainfall and tomatoes scenarios serving as models, this work looks at better adaptation options



that could limit the impact of rainfall variability on tomatoes production and boost tomatoes production in Santa.

The study of Zorom et al. (2013) and Rodriguez Solorzano (2014) on climate variability and adaptation practices by farmers shows the adoption of numerous adaptation strategies to cope with drought conditions. Some of the strategies adopted included the diversification of nonfarm activities such as selling of poultry and rearing of livestock as alternative measures as well as the reduction of food intake. Again, some farmers also engage in the cultivation of dry season irrigated vegetables. They further argued that these practices help farmers to distribute climate risk over different activities which strengthen their financial capacities to be able to raise their purchasing power.

These adaptation strategies adopted by tomatoes farmers in Santa range from changing production techniques to the adoption of improved tomatoes species, irrigation, and the use of agrochemicals and the diversification of activities. Stakeholders' adaptation ranges from the provision of agrochemicals to farmers finance to the provision of farm tools and farm equipment to farmers to help them improve on their production.

Tomatoes production which is a major market gardening crop in Santa has been witnessing a change in the daily, monthly, and annual rainfall in the area.

Variation in the date of onset, amounts, and the retreat of rainfall has affected the growth of tomatoes over the years.

However, the inability of tomatoes farmers to master and cope with rainfall especially the coming of rains has been a major setback to current and future tomatoes production as according to most of the peasants, rainy season during the past years has been very fluctuating and does not begin in mid-March as in the past years; rather, it begins in February and at times comes late and most of the time very irregular, making the availability of water for irrigation very difficult. The few streams and watershed whose water up wells the water needed by plants are vast declining in quantity; this has been a natural occurrence, and these farmers and their crops have an average chance of survival. They loss income, time, and crops.

Dry spells as well as rainy days recorded on this area have been responsible for the outbreak of diseases such as septoria leaf spot, anthracnose, and *Verticillium* which leads to a fall in yields. This is particularly worrisome because farmers have very little strategies as they have resorted in the use of pesticides which has both negative and positive impacts on both the plant and the environment. Most of the time, pesticides are being washed away by heavy downpour due to the fact that most farmers do not know the best times to apply these pesticides. Heavy downpours have led to rapid depletion of the soils in some areas which have completely destroyed large portions of lands with crops. With all these, farmers in Santa have tried to make up for this loss by augmenting the dosage of fertilizers to beef up growth and productivity, but these fertilizers are very bad for the longevity of crops. Looking on the above explanations, the following question will guide us throughout this work: How does rainfall impact tomatoes farming in Santa? What are the farmers doing to remedy the situation?

## **Location of the Study and Research Methodology**

### **Location of the Study Area**

Santa is one of the 32 subdivisions in the northwest region located between latitude 5°42' N to 5°53' N of the equator and longitude 9°58' E to 10°18' E of the Greenwich meridian. It falls within the western highlands agroecological zone and covers a surface area of about 532,67 km<sup>2</sup>. It covers some villages, namely, Akum, Baba II, Pinyin, Baligham, Matazem, and Santa (Njong, Ntarrah, and Mbei), which are our zone of study. This area lies some 20 km from Bamenda and is commonly called “the gateway into the northwest region” with an altitude from 1000 to 2600 m, making the area suitable for the cultivation of market garden crops especially tomatoes (Fig. 1).

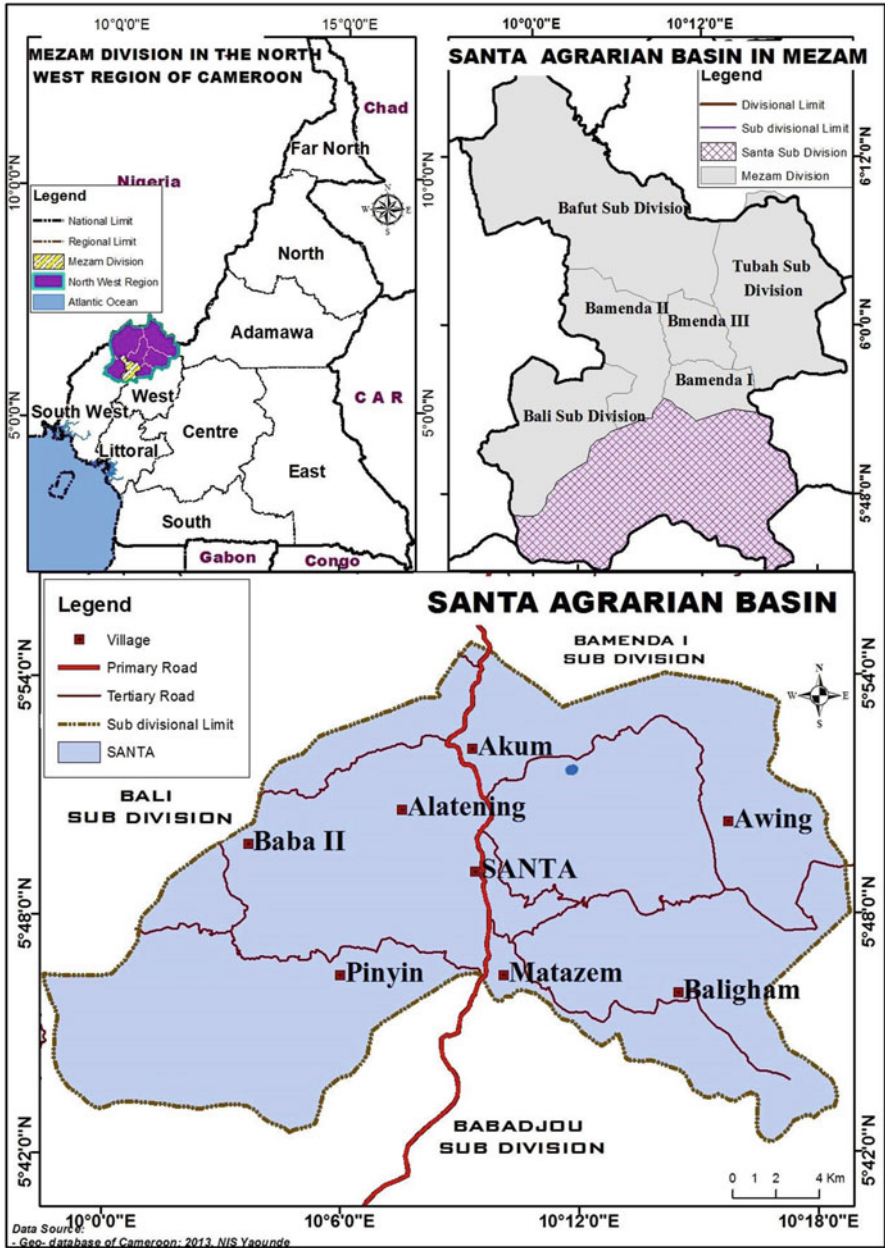
### **Methodology**

#### **Data Collection**

Primary data was collected from key informant such as tomatoes farmer, agricultural extension officers (MINADER and ACEFA), and field officers of research institutes (IRAD). This information was obtained through observations, interviews, and questionnaires. Field observation was very important in making a correlation of questionnaire response by the farmers to the actual remarkable activities in the farm. Field visits were made at different tomatoes farming sites in Santa where different farming, impacts of rainfall variability on tomatoes plants, and adaptation practice were applied with the help of some main tomatoes farmers. A total of 100 questionnaires were taken to the different selected villages, of which 39 were distributed in Ntarrah, 22 in Njong, and 39 in Mbei. Interviews were equally conducted with Farmers in the area who knew the area and had experience in tomatoes production. However, rainfall and output data was equally a secondary data of this study, of which the rainfall data here was obtained from two meteorological stations: Santa and Bamenda stations. The rainfall data used in the study ranged from 1963 to 2011 for the Bamenda station and from 1981 to 2006 for the Santa station. The different quantity of tomatoes harvested by farmers between the years 2001 and 2011 was obtained from the subdivisional delegation of agriculture for Santa and was used hand in globe with the rainfall data to show how rainfall variability has impacted on tomatoes production output over the years in Santa.

#### **Presentation of Results and Discussions**

The state of rainfall variability in Santa is analyzed based on the interannual and monthly anomalies as well as variability in rainfall intensity and rainy days which has really show evidence of rainfall variability in Santa this has greatly impacted



**Fig. 1** Location and layout of the Santa agrarian Basin. (Source: Extracted from Fogwe and Zoum 2014)

tomatoes production in different ways which includes the attack of tomatoes crops by diseases, insects and pest, soil erosion causing infertility of soils, inaccessibility, water shortages most farmers have come out with several adaptation strategies to adapt to the impact of rainfall variability in Santa which has greatly decrease the yields of farmers.

**State of Rainfall Variability in Santa**

**Interannual Anomalies in Santa**

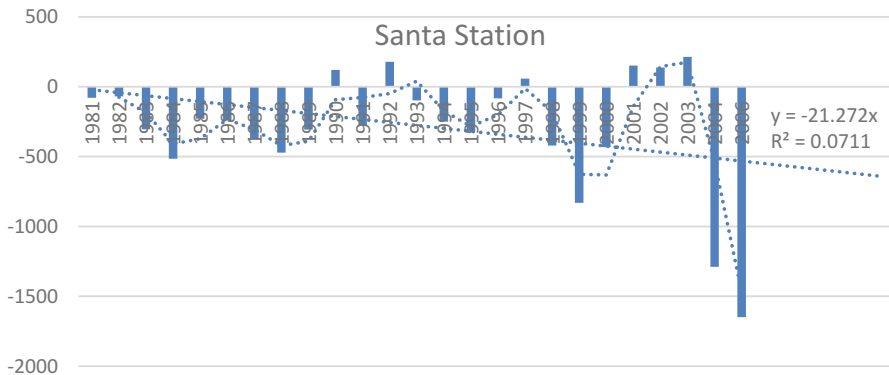
The situation in Santa demonstrates more negative anomalies than positive anomalies as seen.

Figure 2 shows rainfall anomalies in Santa. As already mentioned, years with positive anomalies are fewer than years with negative anomalies. The few years that registered rainfall over the annual average for the periods were 1990, 1992, 1997, 2001, 2002, and 2003. On the other hand, most years had rainfall lesser than the annual average such as the period from 1981 to 1989, 1993 to 1996, 1998 to 2000, and 2004 to 2006. Within these years of less rainfall, the period 2004 to 2006 stands out exceptionally and indicates dry periods.

**Rainfall Variability in Santa**

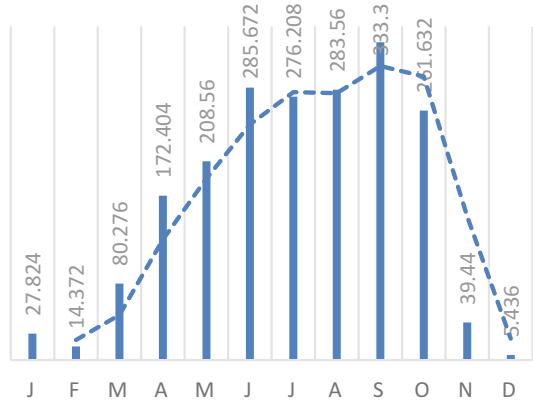
The variability of rainfall equally manifests on monthly basis. Generally, the monthly rainfall pattern affects the seasonal pattern. This area falls within the humid tropical climate with two distinct seasons, a short dry season and a long rainy season. Dry season months record lower rainfall amounts than rainy season months in both Santa and Bamenda stations. Tomatoes production in Santa depends on the pattern of rainfall as it provides water and moisture for plant growth.

Figures 3 and 4 indicate that rainfall is lower for the months of January, February, November, and December. These months are the dry season months. The amounts begin to rise from March which marks the beginning of the rainy season, and the

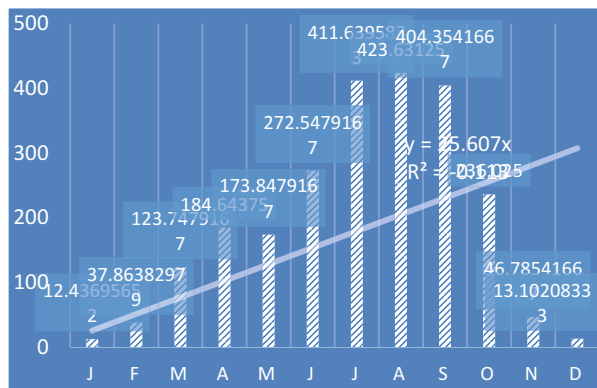


**Fig. 2** Interannual anomalies

**Fig. 3** Monthly rainfall variability in Santa station



**Fig. 4** Monthly rainfall variability in Bamenda station



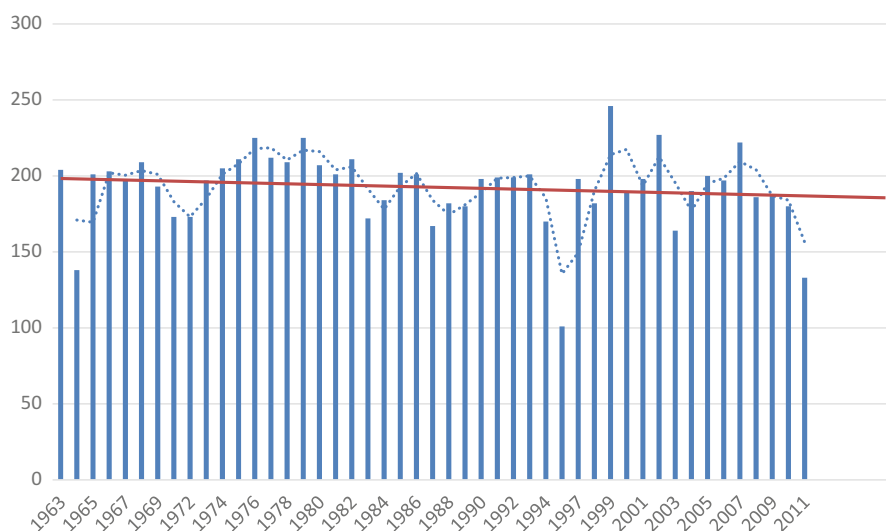
highest amounts are registered in the months of June, July, and August. These months are at the mid of the rainy season.

This trend is the same for both stations, but there is an indication of spatial variability when referring to the two stations. It is observed that rainfall amounts vary within the same months in both stations.

**Variability in the Number of Rainy Days and Rainfall Intensity**

Variation in the number of rainy days and changes in rainfall intensity are some powerful indicators of rainfall variability. This change has a link with fluctuations in the dates of onset and departure of rains. Generally, a rainy day refers to a day that records at least 1 mm of rainfall. The number of rainy days varies according to seasons, but when observed annually, we noticed the days have been fluctuating over the past years in Santa.

Figure 5 shows variability in rainy days from 1963 to 2011 in Santa. The highest number of rainy days was recorded in 1999 (225 days), 1976 (222 days), and 2002



**Fig. 5** Interannual fluctuation in rainy days in Santa. (Source: Fieldwork 2018)

**Table 1** Farm-level adaptation strategies

	Variables	Frequency	Percentages
1	Crop diversification	17	17.34
2	Use of agrochemicals	54	55.10
3	Mixed cropping	4	4.08
4	Irrigation farming	13	13.26
5	Changing crop varieties	10	10.20
	Total	98	100

Source: Fieldwork 2018

(207 days). On the other hand, 1964, 1995, and 2011 had the least number of rainy days (138 days, 101 days, and 133 days, respectively). The annual difference in rainy days is about 124 days which is very large. This is an indicator of rainfall variability because it affects the frequency and intensity of rainfall.

### Peasant Adaptation to Rainfall Variability on Tomatoes Production in Santa

Peasants in Santa have adopted several adaptation options to reduce the impact of rainfall variability on tomatoes production. These impacts are numerous, and the capacity to adopt varies according to farmers and the farm sizes. These adaptation options can be classified into two groups: the farm-level adaptation options and the nonfarm-level adaptation options (Table 1).

Tomatoes farmers in Santa use the farm-level adaptation options such as the use of new species of tomatoes, pesticides, and agrochemicals, changing farming

**Photo 1** Improved variety of tomatoes (F-hybrid species). (Source: Photo by Majoumo 2018)



methods, and irrigation methods in order to reduce the impact of rainfall variability on their tomatoes farms.

### **Adaptation to Improved Varieties of Tomatoes**

The use of improved varieties of tomatoes by most farmers in Santa has been a major response to drought and pest. The new variety used by farmers in this area is the F1-hybrid. According to one of the farmers interviewed (Photo 1):

Hybrids are plants that are a result of cross pollination and they have advantages compared to open pollinated varieties they mature earlier and are uniformly than the other species and are resistant to change in seasons and diseases. (NGU 2018)

### **Adaptation Through Irrigation**

Irrigation is one of the major adaptive strategies that could improve tomatoes yields in era of climate variability (Olwoch and Tshiala 2010). Tomatoes are not resistant to drought. Yields decrease considerably after the short period of water deficiency. It is important to water the plants regularly during flowering and fruit formation. The amount of water that is needed depends on the type of soils. Irrigation is one of the adaptive measures used by famers in Santa during periods of drought and low rainfall. Some of the different irrigation methods used by farmers in Santa on their farms includes the use of water pipes and watering canes to obtain water from wells to water farms, as can be seen in Plate 1.

From Plate 1, Photo 1 shows the sprinkler irrigation method used by tomatoes farmers in Santa to irrigate their farms during period of no rainfall or prolonged dry season, Photo 2 shows the water pipes used by farmers to connect water into their



**Plate 1** The different methods of irrigation used by tomatoes farmers in Santa

farms, and Photo 3 shows another local way of irrigation where farmers dig holes where there is water and use watering canes to carry water to water their farms.

### **Cropping System and Change in the Technique of Production as an Adaptation Option**

Most farmers in Santa use poor farming methods to cultivate their crops which has greatly reduced their yields and also makes the area vulnerable to extreme climatic conditions such as flooding, droughts, as well as soil erosion. Tomatoes farmers in Santa are moving from monoculture to mixed cropping, crop rotation, and intercropping to avoid the risk of reduction in yields as well as crop failure and to equally allow the soils to regain its fertility. It was observed that tomatoes farmers in Santa mix tomatoes with crops such as green beans and lettuce and most of them do carry out intercropping on tomatoes farms.

### **Adaptation Through the Use of Agrochemicals and Fertilizers**

The application of agrochemicals and fertilizers is common to all tomatoes farmers in Santa. The application of agrochemicals and fertilizers improves soil fertility and eradicates crop diseases, insects, and pests. Also, the use of agrochemicals especially fertilizer is a good adaptation strategy that improves tomatoes yields (Tshiala and Olwoch 2010). Most of the farmers in this area apply the NPK 20:10:10 fertilizer in order to increase fertility of their soils especially soils that have been rendered fertile during heavy rainfall or changing rainfall. With the growth of diseases and pest in Santa that affect tomatoes crops, most farmers adapt to use agrochemicals for their crops. An example of pesticide used by farmers in Santa is the CLEANZEB BLUE.



**Table 2** Nonfarm-level adaptation

	Variables	Frequency	Percentages
1	Diversification of nonfarm activities	45	45.91
2	Migration	53	54.08
	Total	98	100

Source: Fieldwork 2018

### **Diversification to Off-Farm and Nonfarm-Level Activity Adaptation Strategies**

Diversification to nonfarm and off-farm activities is one of the adaptive measures that is not popular to tomatoes farmers in Santa, but it was much preferred by most them as it was seen that most of the farmers in that area do carry out other activities such as trading, bike riding, and dress making, just to name a few. Some of these farmers even migrate to other areas in search of jobs especially in urban centers as shown in Table 2.

Table 2 shows the different off-farm adaptation options adopted by farmers in Santa. 54.08% of farmers say they diversify into nonfarm activities such as trading, teaching, and bike riding, just to name a few, while 45.91% migrate to other areas to obtain lands that are more fertile and to areas they think do not suffer from extreme weather conditions or in search for jobs. Respondent explained that the tomatoes business is the main source of livelihood bequeathed to them by their forefathers.

## **Conclusion and Future Prospects**

This study has been able to come out with the state of rainfall variability on tomatoes production in Santa and some of the adaptation options adopted by farmers to remedy the situation. Rainfall events in Santa fluctuate seriously around the mean values. Data from two meteorological stations were analyzed and show yearly, monthly, and daily rainfall variability.

Spatial rainfall variability in the area shows that rainfall has become intense and fall over short duration varying from one area to another. This was analyzed in this work due to the fact that data for this study was obtained from two stations found on the same geographical locations. Temporally, as years goes by, rainfall is becoming very unreliable and varies greatly within the same months.

Extreme weather events such as heavy rains, drought, and flooding are increasingly becoming common in Santa, their occurrence determines the length of growing period, distorts the plants through diseases insects and pest during the plants life cycle, soil lost through flooding and erosion is one of the characteristics of rainy seasons in this area. Most of the farmers in the area are becoming aware of the situation as they have perceived the presence of rainfall variability in the area through the different ways in which it manifest.

In order to adapt to the situation, most of the farmers resorted in the use of irrigation, agrochemicals, mixed cropping, and diversification in nonfarm activities which have greatly helped them to improve on their productivity over the past years.

## Future Prospects

The introduction of various adaptation strategies by the government and/or stakeholders, including the method of distribution of the agricultural inputs, was found to be very uncertain and partly unacceptable by most farmers in the study area. Thus, there is a need of further studies in this area to explore and develop the best method that will be efficient and effective.

Furthermore, an improvement in agricultural research will provide a backbone for adaptation measures. This is because research rapidly changing situations is different from research for stable conditions. Therefore, traditional knowledge is a suitable entry point but very insufficient in a changing situation. So tomatoes varieties need to be developed for future conditions as their applicability cannot be assessed at the location where they may be used in the future. The results of the research have to be published in an environment in which methods and crop varieties are accessible for use.

The analysis of the effect of rainfall variability on tomatoes production indicates that farmers do face production losses since the study area is vulnerable to rainfall and tomatoes production and tomatoes are one of the market gardening crops mostly cultivated by farmers in Santa. It is very important to develop a drought-resistant tomatoes variety that can withstand drought and extreme weather conditions and help to improve yields. It is therefore imperative that institutes such as crop research institutes like IRAD in the country develop more resistant drought varieties to withstand extreme weather conditions.

---

## References

- Fogwe ZN, Zoum BC (2014) Perception and adaptation ajustements to climate variability by Farmers within thé Santa agrarian Basin, 27–31pp.
- IPCC (2007) The fourth assessment report
- Olwoch JM, Freddy TM (2010) Thé impact of climate change and vraiblility on tomatoes production in thé limpopo province South Africa, 88–99pp
- Rodriguez S, C. (2014) Unintended outcomes of farmers' adaptation to climate variability: deforestation and conservation in Calakmul and Maya biosphere reserves. *Ecology and Society*. Vol. 19, No 2 , 2pp
- Tsalefac M (1999) Variabilité climatique, crise économique et dynamique des milieux agraire sur les Haute terres de l'ouest Cameroun. Thèse de Doctorat d'Etat de lettre et the science humaine, spécialité, option climatologie, Université de Yaoundé, 564p
- Tshiala MF, Olwoch JM (2010) Impact of climate variability on tomato production in Limpopo province, South Africa. *Afr J Agric RES*. 13-20p
- Zorom M, Barbier B, Mertz O, Servat E (2013) Diversification and adaptation strategies to climate variability: a farm typology for the Sahel. *Agric Syst* 116:7–15

**Open Access** This chapter is licensed under the terms of the Creative Commons Attribution 4.0 International License (<http://creativecommons.org/licenses/by/4.0/>), which permits use, sharing, adaptation, distribution and reproduction in any medium or format, as long as you give appropriate credit to the original author(s) and the source, provide a link to the Creative Commons license and indicate if changes were made.

The images or other third party material in this chapter are included in the chapter's Creative Commons license, unless indicated otherwise in a credit line to the material. If material is not included in the chapter's Creative Commons license and your intended use is not permitted by statutory regulation or exceeds the permitted use, you will need to obtain permission directly from the copyright holder.





# Rainfall Variability and Quantity of Water Supply in Bamenda I, Northwest Region of Cameroon

# 38

Zoyem Tedonfack Sedrique and Julius Tata Nfor

## Contents

Introduction .....	714
Literature Review .....	715
Climate Variability and Water Supply .....	715
Adaptation to Climate Variability .....	716
Location of Study Area and Research Methodology .....	717
Location of the Study Area .....	717
Research Methodology .....	719
Results and Discussions .....	719
Interannual Rainfall Variability and Anomalies .....	720
Monthly Rainfall Variability and Anomalies .....	721
Fluctuation in Number of Rainy Days and Rainfall Intensity .....	722
Analyses of Rainfall Variability in Bamenda I Using Climatic Indices .....	723
Impacts of Rainfall Variability on Water Supply .....	725
Adaptation Measures .....	728
Conclusion and Future Prospects .....	732
Future Prospects .....	732
References .....	732

## Abstract

Bamenda I municipality found in the humid tropic is endowed with a dense hydrological network which makes it a water catchment for the entire region. Paradoxically, the region still suffers problems of water shortage. This is due to the spatial and temporal variability in rainfall that greatly affects water supply

This chapter was previously published non-open access with exclusive rights reserved by the Publisher. It has been changed retrospectively to open access under a CC BY 4.0 license and the copyright holder is “The Author(s)”. For further details, please see the license information at the end of the chapter.

Z. T. Sedrique (✉) · J. T. Nfor

Department of Geography, Planning and Environment, University of Dschang, Dschang, Cameroon  
e-mail: [saiyddouk@gmail.com](mailto:saiyddouk@gmail.com); [jtnfor2007@yahoo.com](mailto:jtnfor2007@yahoo.com)

© The Author(s) 2021

W. Leal Filho et al. (eds.), *African Handbook of Climate Change Adaptation*,  
[https://doi.org/10.1007/978-3-030-45106-6\\_139](https://doi.org/10.1007/978-3-030-45106-6_139)

713

through its impacts on surface and groundwater. For this reason, we came up with the research topic “**Rainfall variability and quantity of water supply in Bamenda 1, Northwest Region of Cameroon.**” The objective of this study is to examine the manifestations of rainfall variability, and how it affects quantity of water supply in the humid tropics. Rainfall data use for this study comprised of annual, monthly, and daily rainfall over a period of 55 years. Water supply data was made of monthly and annual supply. With these data, a Pearson’s correlation was computed, and it gave a value of 0.701, with a rainfall proportion of 49.14% and 50.86% for other factors. The seasonality and the Standardized Precipitation Index were equally analyzed. At the end of the study, results showed that rainfall events in Bamenda I fluctuates with time and in space. It equally presented a reduction in the number of rainy days from 204 days in 1663 to 155 in 2018. This led to a reduction in length of rainy season and in rainfall amounts. In addition, the area has witnessed sedimentation of riverbeds and water reservoirs due to erosion and deposition during high rainfall peaks. Equally, floods observed during high rainfall episodes have become a potential threat to water infrastructures imposing exceptional water shortages during the rainy seasons. Due to these, actors in the water supply sector are putting in measures to remedy the situation.

---

**Keywords**

Rainfall variability · Water supply · Stream flow · Water catchment · Vulnerability · Adaptation measures · Bamenda I

---

**Introduction**

The Intergovernmental Panel on Climate Change (IPCC 2008) relates that there is a consensus that increases atmospheric greenhouse gases and will result in climate change which will cause: rise in sea levels, increased frequency of extreme climatic events including intense storms, heavy rainfall events, and droughts. This will increase the frequency of climate-related hazards on water resources. There is less consensus on the magnitude of change in climatic variables, but several studies have shown that climate change will affect the availability and demand for water resources. Tsalefac (2007) and Wilby et al. (2006) defended the idea that if global warming averagely increases, isotherms will be displaced, leading to a modification of ecosystems and hydrological cycle, and therefore consequent impacts on both surface and groundwater. Climate variability in general and rainfall variability in particular are ills that are affecting mankind today with highland areas being the most vulnerable to the changes in climatic patterns and its related impacts on water resources. As such, this work explores the state of rainfall variability in Bamenda I and its impacts on the quantity of water supply. Our aim is to show how changing rainfall pattern in space and in time as well as extreme weather events such as torrential rains, floods, and droughts have led to disastrous impacts on the water resource and on the water system.

This work analyzes rainfall data from 1963 to 2018 as well as water supply data from 2012 to 2018 with efforts to understand how quantity of water supply has varied with the past and current changes in rainfall patterns. It focuses on the impacts of extreme rainfall events on water supply in the Bamenda I municipality. According to the national plan of action for integrated water resource management (PANGIRE 2013), Cameroon has a dense river network and both surface and groundwater resources are available but not evenly distributed, and both physical and human factors influences the state and availability of its fresh water resources. These factors include climate change, sedimentation of riverbeds, floods, deforestation, physical and chemical contamination, as well as government policies on both waste management and fresh water management. The Bamenda I municipality, found in the humid tropics ought to have had abundant water due to its geographical, geomorphological, geological, and hydrological features. Paradoxically, this region suffers problems of water supply. This is due to the past and current episodes of seasonal droughts and floods caused by heavy and varying rainfall patterns that continue to affects discharge in river basins. The seasonal fluctuations in the quantity of water supply in this locality are equally attributed to the variations in daily, monthly, and annual rainfall variability. These variations have greatly affected the supply of water to the catchment (surface stores), as well as to reservoirs and consequently to different supply points despite the water potentials in the municipality. This work therefore considers rainfall variability as a major constraint to quantity of water supply in the Bamenda I municipality and aims at bringing the impacts of rainfall variability on water supply.

---

## Literature Review

### Climate Variability and Water Supply

Much has been said on rainfall (climate) variability and water supply, both in the long term and short term. The impacts of climate on water supply can therefore be seen below.

A group of researchers, Beniston (2003), Sadjin et al. (2005), and Martin Dahinden (2010), who studied mountain and climate change, stand for the idea that mountains are among the most sensitive regions to climate change and that some of the most visible indicators of climate change comes from mountain areas. Their ideas were that mountains are water towers of the world as they provide fresh water to more than half of the world's population, but these areas are also among the most sensitive and vulnerable to climate change.

According to Adefolalu (1993) in his study on precipitation, evapotranspiration, and the ecological zones in Nigeria, he explained the fact that during rainy season, it is not expected to have precipitation on daily basis. However, when breaks of equal or more than three pentads (15 days) occur, they are considered serious anomalies. Also, climate change (prolonged dryness) can lead to the drying up of springs, and it is projected to reduce renewable surface water and groundwater resources

significantly in most dry subtropical regions. This will intend to increase the frequency of meteorological droughts (less rainfall) which is likely to increase the frequency of hydrological drought (less surface water and ground water).

Jiduana et al. (2011) explained the variations in the evolution of rainfall patterns and laid emphasis on the fact that the quantity of rainfall and its duration is experiencing a simultaneous decrease in Nigeria which is remarkable to about 78.6% while the intensity of the rainy days and rainy season decreased equally to 77.3%. The study equally permitted to analyze that there has been a regression in the stream flow data over the past years in Nigeria, and this is due to a fall in the quantity of rainfall of about 76.8% affecting the level of stream flow, the stream's transportation capacity, and time of annual recharge. Therefore, it is seen that changes in climate parameters has a potential impact on water supply.

Tsalefac et al. (2007), in their contributions to a book titled *Afrique Centrale, le Cameroun et les changements globaux*, prospected that a certain number of potential consequences of climate change can be seen in a more or less precise manner. If global warming averagely increases, isotherms will be displaced, leading to a modification of ecosystems, mutations in major vegetation types with a great reduction in the forest surface (wood). Drought will increase in the tropical latitudes and thereby increase the risks of extreme weather conditions. This will lead to a reduction in surface and groundwater. Also, certain ecosystems that are very fragile will be particularly sensible to climate change, notably the mountain and coastal ecosystems.

## Adaptation to Climate Variability

In the phase of hydrological changes and fresh water-related impacts, vulnerability, and risk due to climate change, there is need for adaptation and for increasing resilience. Managing the changing risks due to the impact of climate change is the key to adaptation in the water sector and risk management should be part of decision-making and treatment of uncertainty (IPCC 2014). To exploit the impacts of climate change on fresh water, adaptation is generally required; there is growing agreement that an adaptive approach to water management can successfully address uncertainty due to climate change.

According to a group of scholars Mark et al. (2008), adaptation strategies to rainfall variability include household water treatment and safe storage (HWTS), water storage and conservation techniques, water reclamation and reuse technics, increasing use of water-efficient fixtures and appliances. These strategies are grouped in to six typology of adaption technologies which are diversification of water supply, groundwater recharge, preparation for extreme weather events, resilience to water quality degradation, storm water control and capture, and water conservation.

Another group of researchers, ML Parry et al. (2007), in water supply sanitation (WSS) propose sector-specific models, which included upgrading existing infrastructure to meet future challenges and cope with the risks associated with climate

change. Example, installation of pre-sedimentation pond or riverbank filters for pretreatment, shifting from shallow wells to more reliable sources of water supply, such as surface water and confined aquifers. It was equally concerned with improving water supply through master plan and long-term investment plan including an inventory of groundwater resources. They equally implemented complementary measures, which included the introduction of disaster and climate risk assessment, and improving general framework for risk assessment and management, establishing system for managing floods and other climate and water-related disasters. According to them a proper adaptation could equally be done through protecting water intake facilities from flooding, protecting pumping stations and treatment plants or other facilities potentially exposed to flooding and encouraging the use of alternative water sources, such as (treated) wastewater reuse and rainwater harvesting, to minimize dependence on freshwater and secure access to stable sources of water. Recent experience in Moldova confirms that well properly designed and operated basic treatment plants can deliver even under extreme weather conditions.

---

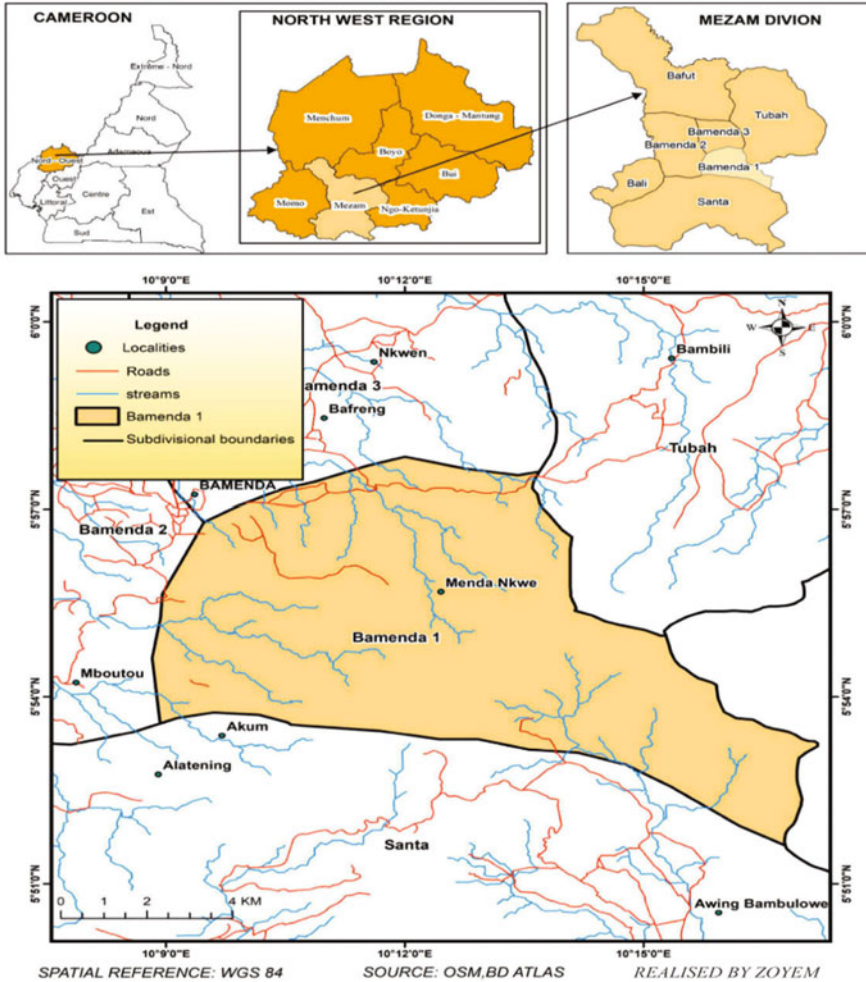
## Location of Study Area and Research Methodology

### Location of the Study Area

Bamenda I subdivision is situated Southeast of Mezam division, one of the seven divisions of the Northwest region of Cameroon. It is located within latitude 5°51" to 5°58" north of the equator and longitude 10°8" to 10° 17" east of the Greenwich meridian, (Fig. 4). It falls within the humid tropical climatic zone and covers a total surface area of about 110 km<sup>2</sup> with one main village (Bamendakwe) comprising of about 13 quarters, namely, Abangoh, Achichum, Alahnting, Aningdoh, Banche, Nkar, Ayaba, Ntanche, Ntafebuh, Nta'afi, Moyo, Keneleri, and Abumuchi. This municipality is situated at the entry to Bamenda town, and it is oriented 366 km northwest of the Cameroon capital with an altitudinal range from about 1269 to 2606 m above sea level.

As seen on Fig. 1, the Bamenda I municipality is bounded to the north by Bamenda III subdivision, to the south by Santa, to the east by Tubah and Balikumbat, and to the west by Bamenda II subdivision (Flyer Bamenda I council 2018). It is connected to the national territory by the national road N°6. Its geographical location falls within the Guinean climate type. This climate varies from one area to another, and it equally varies with altitudes (thermal gradient) and seasons. The climate is marked by two distinct seasons which are the dry and rainy season. The rainy season is usually from around mid-March to mid-October and sometimes extends to November. The rainfall ranges between 2000 and 2500 mm per annum and highest amounts are recorded in July and August. Heavy torrential rainfall in this area usually results from strong Southwest Monsoon winds blowing into the country from the Atlantic Ocean. These rainfall amounts lead to a considerable recharge of the water table and consequently an increase in stream volume, thereby leading to adequate supply of water to the entire municipality.





**Fig. 1** Location of the study area

On the other hand, dry northeast trade winds from the Sahara Desert blow to the national territory through the northern part of the country, from November to January. The dry season is usually from mid-October and or November to around mid-March. Strong winds and heavy cloud cover characterize the area due to convectional heating. The altitudinal range gives it a highland average temperature of about 19.4 °C with about 18 °C around water catchments, confirming the reduction of temperatures with altitudes. Equally, this area registers average relative humidity of about 76.9%. These moderate temperatures are friendly to water conservation as very little is lost through evaporation. On the other hand, high humidity conditions the availability of moisture in the atmosphere. The area also receives

insulations of about 6–8 h/day, reaching its peak in January when the northeast trade winds sweeps across the area. This leads to some cloud formations on the highlands of Mendankwe, and during such occurrences, potential cases of convectional rainfall are recorded. These climatic parameters are favorable for the natural supply of water to the catchments and subsequently to the water system there by qualifying this area as a watershed for the entire locality. It is clearly seen on Fig. 1, as most rivers take their rise from the municipality and flows to different areas.

The area is equally located on the western highland plateau, along the Cameroon dorsal, which runs from Mount Cameroon in the southwest passing through Mount Manengouba and Mount Bamboutos in the west, and stretching to Mount Oku in the northwest. High altitudes with series of mountain chains are common in this area. The locality therefore presents a wide range in its relief forms, with altitudes ranging from 1269 to 2606 m. This range permits an ample downflow of water to the rest of the municipality and beyond. The zone is therefore considered a watershed for the entire region since most rivers and streams draining the region take their rise from its highlands.

## **Research Methodology**

### **Data Collection**

Both qualitative and quantitative data were gotten from respondents in the zone of study, and the data was from primary as well as secondary sources. Primary data was mostly qualitative and comprised of observations made, interviews conducted, and questionnaires administered to both the water management committee and the local population. This information was obtained using questionnaires and interview guides, where 99 questionnaires were successfully administered to seven quarters and returned. Secondary data were both quantitative and qualitative. Quantitative secondary data comprised of the total quantity of water abstracted and supplied in Bamenda I from 2012 to 2018, collected from the Cameroon Water Utility Corporation (CAMWATER), and of rainfall data for Bamenda Station from 1963 to 2018, collected from the chief in charge of the meteorological station at the Northwest Regional Delegation of Transport. These data were used firstly to characterize rainfall events in the Bamenda I municipality, secondly to determine the Standardized Precipitation Index (SPI) and the rainfall seasonality index, and finally the Pearson's correlation coefficient.

---

## **Results and Discussions**

Manifestations of rainfall variability in Bamenda I was evaluated through analyses of interannual rainfall variability and anomalies, analyses of monthly rainfall variability and anomalies, fluctuation in number of rainy days and in rainfall intensity, and through the application of climatic indices. Also, the Pearson's correlation

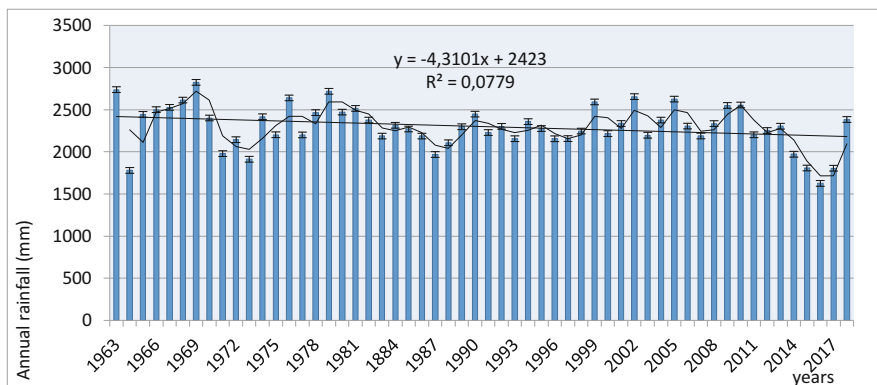
coefficient was used to evaluate the extent to which manifestations in rainfall affect water supply quantity. These manifestations have consequent impacts on water resource availability or stream discharge in catchments, on riverbanks and on the water systems. This is due to heavy downpours that cause massive erosion in the drainage basin, landslides along river banks, and sedimentation in water reservoirs.

## Interannual Rainfall Variability and Anomalies

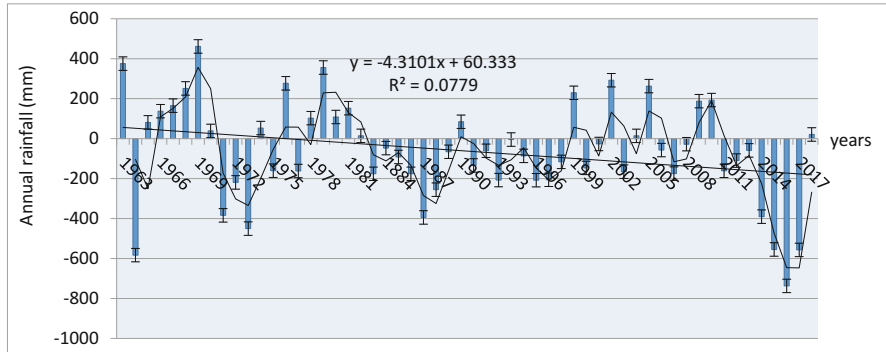
Rainfall variability in Bamenda I manifest through fluctuations in annual rainfall amounts seen as some years registered more rainfall amounts than others. It equally manifest through annual rainfall anomalies as seen on Figs. 2 and 3, respectively.

As seen on Fig. 2, there have been great variations in annual rainfall amounts over the study period. This is seen as some years registered high rainfall amount (above the means of 2362 mm), while others registered low rainfall amounts (below the mean). High amounts of rainfall where registered in 1963 (2800 mm), in 1969 (2900 mm), in 1981 (2500 mm), and in 2018 (2400 mm), while low rainfall amounts were registered in 1972 (2200 mm), in 1973 (1800 mm), in 2014 (2000), and in 2016 (1600 mm). There have been a general fall in rainfall amount over the past 55 years, indicated by the depressing trend line. This is in line with global trends of falling rainfall with time due to changing climate, IPCC (2008).

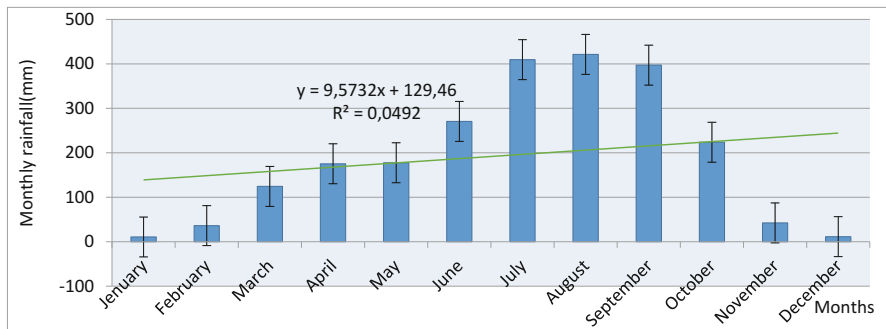
On the other hand, Fig. 3 illustrates rainfall anomalies, and it is seen as some years registered positive rainfall anomalies and others negative rainfall anomalies. Example positive anomalies were recorded in years like 1963, 1969, 1976, 1979, and in 2002. They registered anomalies ranging between 300 and 500 mm, while negative anomalies were recorded in 1964, 1973, 2015, 2016, and 2017 with anomalies between 400 and 900 mm. Negative anomalies registered a frequency 60% against 40% for positive anomalies reason for the falling trends.



**Fig. 2** Interannual rainfall variability in Bamenda up station. (Source: Author (2019))



**Fig. 3** Interannual rainfall anomalies in Bamenda I station. (Source: Author (2019))



**Fig. 4** Monthly rainfall variability. (Source: Author (2019))

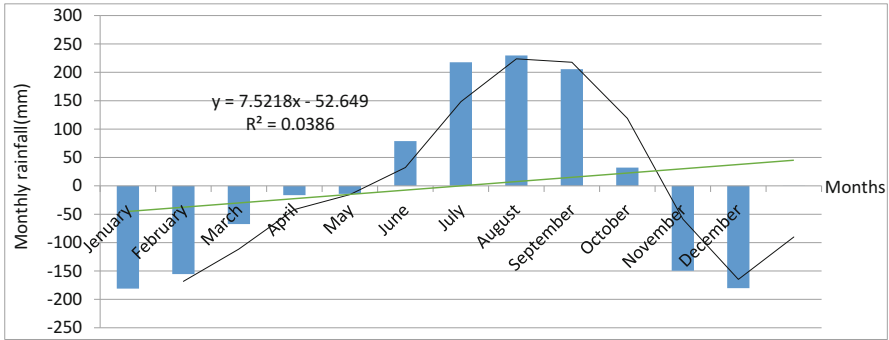
**Monthly Rainfall Variability and Anomalies**

Rainfall variability equally manifests through fluctuations in monthly rainfall amounts and anomalies, but fluctuations follow a seasonal pattern. The mean monthly rainfall was calculated at 191.68 mm and fluctuations went both below and beyond the mean, indicating variations rainfall (Fig. 4).

As seen on Fig. 4, rainfall amounts are lower in months of January with about 10 mm, February with 35 mm, November (42 mm), and December with about 11 mm, as they all register rainfall below the mean of 191.68 mm. The rainfall begins to rise in the months of March (120 mm), which mark the beginning of the rainy season. Its reaches its peak in July (410 mm), and August (420 mm), and starts falling around October (220 mm).

Rainfall variability in the Bamenda I municipality is equally indicated by monthly rainfall anomalies. This is seen as some months record positive rainfall anomalies while others record negative anomalies (Fig. 5).

Figure 5 on the other hand illustrate monthly rainfall anomalies, and it is seen that negative anomalies were recorded in some rainy months (March, April and May).



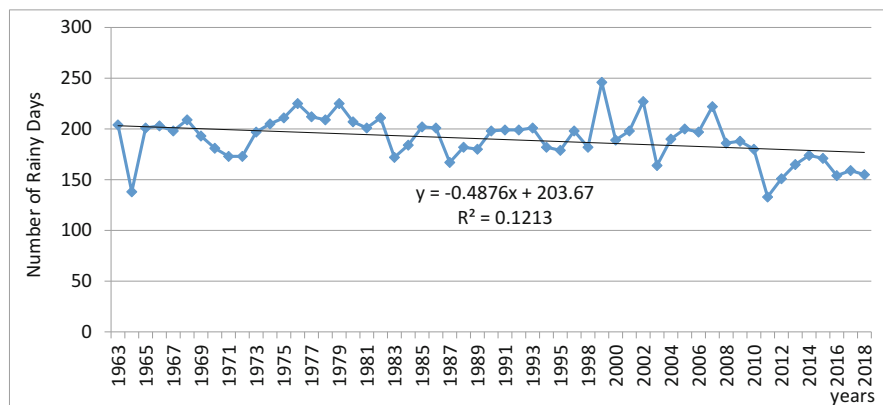
**Fig. 5** Monthly rainfall anomalies. (Source: Author (2019))

This is paradoxical because negative anomalies are expected in months of the dry season, but they are instead recorded in rainy months. This may be accounted for by the late onset of rains leading to an increase of the length of the dry season. This will lead to a drop in the water table, thereby reducing water level in catchment and thus exacerbating water shortages. This confirms the results of Hayward et al. (1987) that “an increase in the length of time for recharge of ground water due to prolonged dry season will cause a drop in the water table and a drying up of some streams and springs on which people depend for survival.”

## Fluctuation in Number of Rainy Days and Rainfall Intensity

Variation in the number of rainy days and changes in rainfall intensity are other indicators of rainfall variability. This variation has a link with fluctuations in the dates of onset and retreat of rains. This link is seen as years with late onset and early retreat will have a higher tendency of registering less rainy days but with higher rainfall intensity while years with early onset and late retreat will have higher chances of recording many rainy days but less rainfall intensities.

Figure 6 shows variability in rainy days in Bamenda up station from 1963 to 2018. This study period has registered a lot fluctuation in number of rainy days as some years registered close to 250 rainy days annually and others about 130 rainy days. Highest number of rainy days were recorded in 1999 (249 days) and in 2007 (225 days). On the other hand, 1964 and 2011 had the least number of rainy days (135 days and 130 days, respectively). The annual difference in number of rainy days is about 119 days, which is much enough to attest that there have been variations in rainfall within the study area. This is because fluctuations in number of rainy days will obviously lead to fluctuations in frequency and intensity of rainfall. This is felt as years with less rainy days and more rainfall amount record high rainfall intensity, while those with more rainy days and less rainfall amount record less rainfall intensity. This is because less rainfall amount is rationed within



**Fig. 6** Number of rainy days. (Source: Author (2019))

**Table 1** Classification of SPI values, categories, and corresponding proportions

SPI value	Category	Probability (%)
2.00 or more	Extreme wet	0.3
1.5 to 1.99	Severely wet	2.4
1.00 to 1.49	Moderately wet	11.2
<b>0 to 0.99</b>	<b>Mildly wet</b>	<b>30.1</b>
<b>0 to -0.99</b>	<b>Mild drought</b>	<b>37.4</b>
-1.00 to -1.49	Moderate drought	14.2
-1.50 to -1.99	Severe drought	4.4
-2 or less	Extreme drought	0

Source: McKee et al. (1993)

the many rainy days and consequently, low rainfall intensity, whereas with the few rainy days, much rainfall amount is pouring per unit area, and hence high rainfall intensity.

## Analyses of Rainfall Variability in Bamenda I Using Climatic Indices

Climatic indices were equally used to characterize rainfall variability in Bamenda I, and both the seasonality and the standardized precipitation index were used (Tables 1 and 2).

### The Standardized Precipitation Index (SPI)

The Standardized Precipitation Index (SPI) is a tool used primarily for defining and monitoring drought and floods (rainfall situation). It equally serves as a method of

assessing climatic variability. It was developed by McKee et al. in 1993. It was therefore used to assess the situation of rainfall variability in Bamenda I (Table 1).

As seen on Table 1, 0.3% of the study period registered SPI values greater than or equal to 2.00 indicating extreme wet conditions. This implies that the probability of occurrence of extreme floods in Bamenda I is 0.3%. Equally, 2.4% of the study period registered values between 1.5% and 1.99% corresponding to severely wet conditions. Also, 11.2% recorded moderately wet and 30.1% recorded mildly wet conditions. To what concerns drought conditions, 37.4% lived mild drought, 14.2% lived moderate drought, and 4.4% lived severe drought conditions, but no situation of extreme drought was witnessed. The SPI therefore indicates that mild wet and mild drought conditions are most common in Bamenda I since they have the highest probability of occurrence.

### The Seasonality Index

The seasonality of precipitation refers to the tendency for a place to have more rainfall in certain months than in others. It therefore determines the rainfall regime of a particular place (length of seasons). This makes use of the seasonality index (SI) of Walsh and Lawler (1981). Table 2 presents the seasonality index for Bamenda I.

Table 2 shows the scale (class limit) of the seasonality index and their corresponding seasonal regime. The seasonality index for Bamenda up station is calculated at an overall value of **0.901**, and as seen on the scale, this value falls within the limit **0.80 to 0.99**. This means that the rainfall regime for Bamenda station portrays a markedly seasonal with a long drier season instead of a seasonal regime. Instead of seasonal because humid tropics (Bamenda) are characterized by two distinct seasons, so we should normally have a “seasonal” rainfall regime with a well-defined rainy and dry season but instead of a seasonal regime, it shifted to a “markedly seasonal with long drier season.” This is a clear indicator of a variation in rainfall, and it also indicates that rainfall in Bamenda I has been reducing gradually, leading to higher trends of drought occurrence. This result is in line with that of Jiduana et al. (2011), in Northern Nigeria, which emphasizes on the fact that “rainfall amounts and its duration is experiencing a general decrease.” This explains why rainy months of March, April, and May portray negative anomalies, with rainfall

**Table 2** Rainfall seasonality index and corresponding regimes

Seasonality index class limit	Rainfall regime
≤0.19	Very equable
0.20–0.39	Equable but with a definite wetter season
0.40–0.59	Rather seasonal with a short drier season
0.60–0.79	Seasonal
<b>0.80–0.99</b>	<b>Markedly seasonal with long drier season</b>
1.00–1.19	Most rain in 3 months or less
≥1.20	Extreme, almost all rain in 1–2 months

Source: Walsh and Lawler (1981)

below the normal. This fall in rainfall and occurrence of droughts will obviously lead to a fall in the general quantity of water supply in Bamenda I.

## Impacts of Rainfall Variability on Water Supply

This section deals with the effects of variation in rainfall on water supply. These variations in rainfall pattern and amount have caused several impacts on the water system. They include intense erosion within river channel leading to occurrence of landslides, sedimentation in water collection chambers leading to its blockage, and erosion along pipeline network leading to breakage. Also, meteorological droughts lead to shrinking of rivers and springs. It equally shows the Pearson's correlation coefficient between monthly rainfall amount and water supply.

### Pearson's Correlation Coefficient Between Rainfall Variability and Water Supply

The Pearson's correlation coefficient is a measure of the linear correlation between two variables. It is a tool for determining the strength of a relationship existing between two variables. It was therefore used to establish the relationship between rainfall and water supply in Bamenda I.

From Table 3, the Pearson's correlation coefficient is 0.701. This positive value shows a direct relationship between monthly rainfall and monthly water supply in Bamenda I. Meaning that an increase in rainfall amount will lead to an increase in quantity of water supply while a fall in rainfall will condition a fall in water supply quantity (in monthly or seasonal bases). This is because an increase in rainfall amount due to the outbreak of the rainy season will progressively recharge the water table and increase its level thereby increasing the volume and level of surface and groundwater, respectively, this will consequently increase quantity of water abstracted and supplied in the municipality.

Though the correlation coefficient indicates a strong positive relationship (+0.701), it is not up to a total positive relationship (+1), implying that other factors influence quantity of water supply in Bamenda I. To determine their contribution, the coefficient of determination was calculated, and the proportion of rainfall was determined. This coefficient gave an  $R^2$  value of 0.49 and a rainfall proportion of 49.14%. This percentage shows the contribution of rainfall on the changes observed in quantity of water supply, therefore the remaining 50.86% indicates the contribution of other factors. These factors include demographic increase, urban expansion, infrastructural, and managerial factors.

**Table 3** Pearson's correlation coefficient between monthly rainfall variability and water supply

Variables tested	Pearson's correlation coefficient (r)	Coefficient of determination ( $R^2$ )	Proportion of rainfall in the change
Rainfall (mm) and water supply ( $m^3$ )	0.701	0.49	49.14%

Source: Author (2019)



### High Rainfall Intensity and the Water System

Occurrence of torrential rains in this area is usually accompanied by heavy downpours, which generally constitutes more of overland flow than infiltration. This is because the steep topography limits chances of infiltrate and rather permits runoff. These conditions will therefore lead to occurrence of surface runoffs, which flow into rivers and increase their volumes. This increase in river volume will increase its force and action within the channel, and this will lead to the occurrence of landslides along its banks. On the other hand, runoffs mostly transport sediments and debris, which ends up blocking water intakes and damaging transmission pipes, thereby preventing water input and output into and out of the system (Plate 1).

As seen on Plate 1, landslides occur due to intense erosive activities along the river course due to intense rainfall episodes (Photo 1). Equally, the transportation of sediments and deposition within the river channel leads to blockage of water collecting chambers and consequently, no inputs into the water system. Also, the occurrence of gully erosion will lead to the exposure of and further damage on pipelines and in such situations, outputting will be hindered, (Photo 3). When these phenomena take place, the entire water system is disrupted, and water crises are witnessed in the municipality.

### Droughts and Natural Supply

When meteorological droughts persist, hydrological droughts develop. The term “drought” can have different meaning to different people, depending on how a water deficiency affects them (Moreland et al. 1993). To the people of Bamenda I, droughts are condition of persistent dryness that leads to a reduction in stream flow and groundwater levels, thereby causing water shortages. Prolonged occurrences of this drought therefore lead to shrinking of their water sources (streams, springs, and wells) and in some cases, it leads to the complete disappearance of some streams, (Plate 2).

As seen on Plate 2, there is a drastic fall in the volume of stream flow (Photo 1), shrinking of springs (Photo 2), and complete disappearance in stream flow as seen on Photo 3. These situations are found in Nkar, Ntanche, and Alahnting, respectively.



**Plate 1** Impacts of heavy downpour on the water system



**Plate 2** Impacts of drought on natural supply



**Plate 3** Impacts of drought on supply points

This is caused by three main factors: firstly by lack of precipitations to recharge surface and groundwater, secondly by prolonged evaporation that lead to direct water lost, and lastly by uptake and transpiration from vegetation that reduce both ground- and surface water. Intense insulation and high temperatures often amplify this situation. This result supports the thesis of Adefolalu (1993). On the idea that “climate change can lead to drying up of springs and is projected to reduce surface and ground water resources significantly in most subtropical regions.” This reduction in stream flow will reduce quantity of natural supply, thereby reducing input of water to the system, and this will lead to a drastic reduction in total quantity of water supplied within the municipality.

This fall in supply has led to the shutdown of most public supply spots since available water quantity is no longer sufficient to supply all points, (Plate 3).

Plate 3 illustrates shutdown of water supply points due to scarcity in water resource. This is the case of Akumbele and Ntafebuh on Photos 1 and 2, respectively. This occurs because a fall in natural supply due to meteorological drought will lead to a reduction in input to the water system. This reduced in input will lead to a

reduction in the quantity of water abstracted and stored in reservoirs, consequently, there will be shutdown of most public supply points since water quantity is no longer enough to freely satisfy the population.

## Adaptation Measures

Households and stakeholders have put in place a wide range of measures to adapt to rainfall variability and reduce its effects on water supply in Bamenda I. They range from drilling of boreholes and wells, spring source coverage, use of rainwater collection systems (during rainfall episodes), and through the application of water catchment protection and management measures such as construction of life fences, planting of water friendly trees, slanting and enlarging river banks, and engaging the local population in catchment protection.

### Drilling of Boreholes Wells

Surface water sources have become exposed and vulnerable to climatic and environmental hazards such that people were forced to adapt through use of alternative water source. This change was from the use and dependence on surface water sources to groundwater source, which are less exposed and sensitive to the effects of climatic hazards. These surface water sources include boreholes and well.

### Spring Source Coverage

To reduce the effects of runoffs, mudflow, and consequent pollution on spring source, the local population constructs protective layers on spring sources. These layers are locally constructed using cement and sand (Plate 4, Photo 2). This is done by joint contribution from the inhabitants of the quarters concerned.

### Use of Rainwater Collection System

The use of rainwater over the years has gained its importance as a valuable alternative or supplementary water resource. This is due to the growing scarcity of



**Plate 4** Adaptation to climate-induced effects on water sources

ground- and surface water caused by extreme weather conditions. Households therefore witness water shortage and seizures in the dry season as well as in the rainy season. Seizures in the rainy season are often because of intense rainfall that creates damages around stream catchments preventing water inputs and limiting supply. To remedy water shortage during these periods, some households install rainwater collection systems to increase their water supply. Others use containers to collect water dripping directly from roofs. All these measures are clearly illustrated on Plate 4.

Plate 4 illustrates adaptation measures mainly by the local population to combat the effect of climate extreme on water sources in order to maintain and perhaps increase domestic supply quantity. Photos 1, 2, and 3 show use of wells, spring source coverage, and rainwater collection system, respectively.

Photo 1 shows a domestic well, and it consists of a digged hole down to the water level. Its water is stored within the hole, and its depth is less compared to that of a borehole. This water source is less vulnerable to climatic extremes, and it ensures a steady supply regardless of seasons. Its steady supply is because it is alimented by aquifers, which are less vulnerable to extreme weather conditions. This water source is therefore used as an adaptive source.

The arrow in Photo 2 points out the protection chamber constructed on a spring outflow. This is to prevent the runoff and mudflow into spring sources. This preventive measure will ensure steady water supply without interruptions especially during and after rainy periods. This situation is common in Ntanche and Aningdoh, respectively. Photo 3 illustrates a household rainwater collection system and this system is used to harvest and store water from roofs during rainfall episodes. Rainwater harvesting and storage is done with pipes, which are connected to gutters permitting to link water from the roof to the storage containers. Water is harvested and stored for further use, especially when the stream supply system fails.

Other domestic measures of adapting to water shortage brought by extreme weather conditions include: increase use of storage containers, buying mineral water from shops and from water vendors, regulating water use, use of stream water, and practicing of household water treatment and storage measures. Those with borehole at times use generators to pump water into reservoirs during periods of power failures. This is common in dry season due to a fall in dam discharge caused by excess meteorological drought that reduces water recharge in the dams. This reduction in water recharge reduces power supply to the electrical system, and this increases the rate of power failures. As such, those with electrical-based water systems are forced to use alternative power supply measures to electrify their systems. The frequency of implementation of adaptation measures depends on the extent to which rainfall variability affects their sources of supply.

### **Adaptation Through Catchment Protection and Water Management Measures**

Water catchment management (WCM) refers to a range of measures and policies implemented on water catchment in order to reduce environmental, climatic, and anthropogenic actions. It equally involves the management of water catchment

through taking precautionary measures to prevent or reduce environmental and climatic hazards on drainage basins and or catchment areas. It also concerns the sustainable use of water resource and land within the watershed. Actors involved in these activities include the Ministry of Water and Energy (MINEE), the Cameroon Water Utility Corporation (Camwater), and the Bamenda I sub divisional council. There is equally the role of the local community and anonymous individuals. These WCM measures are aimed at providing sustainable supply of water in terms of both quantity and quality of water. They include:

- **Construction of life fences.**

To fight against erosion, there was the planting of life fences round the water catchment areas, both by the subdivisional council and the Camwater. These fences are made of wires and backed up by trees to prevent excess erosion from the surrounding into catchment and river channels. They equally help to prevent grazers from invading the catchment with their cattle. All these measures reduce the rate of damages by erosion on river channel as well as prevent the abuse of water resource by grazer.

- **Planting of water friendly trees.**

To combat the problem of excess hydrological droughts in Bamenda I, there was a massive planting of water conservation trees (50,000 *Pygeum africanum* tree) around water catchments. This was done by both the Bamenda I subdivisional council and the Bamendakwe Development and Cultural Association (BAMEDCA). This tree has a little quantity of water uptake and disfavors transpiration. It equally has a large canopy that sheds the catchment and prevents evaporation. Its roots equally hold soil particles together, thereby limiting occurrence of landslides in water catchment. On the other hand, there is a strict restriction on the planting of eucalyptus trees around water catchments. This is due to their high water needs and uptake. All these reduce the level of water lost, thereby conserving water within catchments and ensuring sustainable supply.

- **Slanting and enlarging riverbanks.**

Due to the occurrences of landslides along river courses, there was the need to dig along riverbanks in other to gentle the slopes and reduce the action of gravity, which often bring down landmasses along steep riverbanks. Slanting in most cases widens the riverbed, this reduces both the level and the strength of river flow, and this will therefore reduce the erosive action of the river on its banks. This activity is at times accompanied by the planting of trees along river banks which hold soil particles together and reduce the movement and land masses into river channels. This activity is mostly carried out by Camwater.

- **Engaging local population in catchment protection.**

This involves giving scientific knowledge to the local population on how the catchment operates, thereby permitting them to protect the water catchment at the local level and ensuring a lasting supply of water in catchments. This includes sensitizing the local population (especially those around the catchment) on sustainable agricultural practices around the catchment, such as the importance of agroforestry and antislope wise cultivation in other to prevent and reduce

excess erosion and deposition of sediments in river channels. It equally concerns placing restrictions on practices such as grazing within water catchment, farming, and deforestation along river courses. It also involves restriction on waste disposal in river channels and around water catchments, since solid and liquid waste disposal in rivers and open space leads to diverse kind of health problems including water and airborne diseases (Achancheng et al. 2003). On the other hand, this is concerned with the massive participation of the entire community around water catchment during activities such as planting of trees and building of life fences. A reduction in these activities and participation of the local population will provide a friendly milieu for conservation of water in the catchments and hence to improve water resources while ensuring the productivity of any water body for the community that depends on it.

Adaptation measures are equally implemented on storage and distribution facilities. This was in a bit to increase water collection, storage, and hence distribution.

### **Adaptation on Storage Facilities**

To address the problem of water lost to the environment by natural springs, amendments were made on spring sources and reservoirs constructed on them to collect and store flowing water. There was equally the construction of water tower to abstract and store water from aquifers, all these in a bit to store water and prepare for periods of high water demand. Doing so equally reduces the direct impacts of climate extremes on springs especially pollution from runoff and mudflow due to intense rains. This was done by the Bamenda I subdivision council and by the Cameroon-China cooperation. These reservoirs were constructed at Menka, Abangoh, and Mendankwe with a carrying capacity of 18 m<sup>3</sup> each.

### **Adaptation on Distribution Facilities**

To limit the damaging action of erosion, floods, and other external factors on pipelines, the water management committee proceeded to the use of metallic pipes on strategic points (in highly vulnerable zones to erosive actions) on the distribution network. There was equally a considerable increase in depth of pipelines especially in areas with loosed soil particles. These were aimed at minimizing damages on pipe network in other to maintain supply. The water management committee equally puts in place distribution trucks (mobile reservoir) to ensure supply especially to extreme quarters on the distribution network. This is mostly common in the dry season where pressure is not enough to pump water to all localities due to low water levels in reservoirs. This service is common in Achichum, which is furthest on the distribution network, and sometimes in Ayaba, which is higher in altitude. In most cases, the trucks are recharged in areas with adequate water supply and distributed in those with limited supply. All these facilities will therefore increase supply in periods of shortages and in vulnerable zone, thereby increasing the total quantity of water supply in Bamenda I. In addition, during situations where available water cannot adequately satisfy the entire population, there is water rationing to ensure equitable supply to all subscribers.

## Conclusion and Future Prospects

Rainfall is one of the climate parameters which affect water in the entire drainage basin, thereby leading to consequent effects on rivers and their tributaries. This study was based on the impact of rainfall variability on the quantity of water supply in the Bamenda I municipality. Rainfall amounts in the municipality fluctuate around the normal. Its variability is indicated through fluctuations in interannual rainfall variability and anomalies, and through monthly rainfall variability and anomalies. These anomalies are either positive or negative indicating periods of more or less rainfall amounts. Rainfall variability equally manifests through variations in number of rainy days and through fluctuations in rainfall intensity. The rainfall regime was gotten using climatic indices, and the Pearson's correlation coefficient was conducted to determine how quantity of water supply responds to rainfall variability. However, rainfall conditions seasonal variation in quantity of water supply to an extent, since supply is generally higher in rainy than dry seasons (direct relationship), though some cases occurred where periods of intense rainfall instead leads to a drastic reduction in supply (inverse relationship). Extreme weather events such as heavy rains, flooding, and drought are increasingly becoming common in the municipality. Their occurrence distorts the functioning of both the hydrological cycle and the water system, thereby affecting the quantity of water supply in the municipality.

### Future Prospects

Since the study was carried out in the Bamenda I municipality (Bamenda highlands), there is need for further research to expand the geographical scope of the study, in other to do a comparative study of two different drainage basins or water catchments to assess the level of responsiveness of water resources to rainfall variability.

Result from the study showed that beside rainfall variability, there exist other factors, which greatly affect quantity of water supply in Bamenda I. Therefore, further research should be carried out in other to access the validity of these factors.

Equally, an improvement in hydrological research will provide a room for adaptation measures. This is because more research in the domain of water supply will identify more threat to the natural functioning of water catchments (drainage basins), and therefore more suggestion will come up to improve adaptation measures on water catchment.

---

## References

- Achancheng E, Lydie SA, Temitope DT, Corntin YC (2003) Urban cities and waste generation in developing countries: a GIS evaluation of two cities in Burkina Faso
- Adefolalu (1993) Precipitation, evapotranspiration and the ecological zones in Nigeria Dhaka. [http://www.wateraid.org/documents/plugin\\_documents/060721\\_tubewell\\_guidelines.pdf](http://www.wateraid.org/documents/plugin_documents/060721_tubewell_guidelines.pdf)
- Flyer, Bamenda I Council (2018) Physical and human environment of Bamenda I. <http://www.google.com/search?q=pangire+date+of+creation&client=ucweb-b&channel=sb>

[http://www.who.int/water\\_sanitation\\_health/publications/vision\\_2030\\_summary\\_policy\\_implications.pdf](http://www.who.int/water_sanitation_health/publications/vision_2030_summary_policy_implications.pdf)

- Hayward O, Mata LJ, Arnell NW, Döll P, Kabat P, Jiménez B (1987) Climate and Chlorophyll: Long-term trends in the central North Pacific Ocean
- IPCC (2008) Climate change and water. Intergovernmental Panel on Climate Change Working Group II technical support. Jewitt, G.P.W, Schulze R.E (1999). Verification of the ACRU model for forest hydrology applications. *Water SA* 25:483–489
- IPCC (2014) Managing the risks of extreme events and disasters to advance climate change adaptation. A special report of Working Groups I and II of the intergovernmental panel on climate change. Cambridge University Press, Cambridge
- Jiduana GG, Dabi DD, Dia RZ (2011) The effects of climate change on water and agricultural activities in selected settlements in the Sudano-Sahelian Region of Nigeria. *Arch Appl Sci Res* 3:154–165
- Mark E, Andrew A, Joseph L, Jamie B (2008) HWTS education: a hidden success in emergency situations” Presentation at the “Water and Health: Where Science Meets Policy” conference. Chapel Hill, USA. October 26, 2010
- McKee TB, Giddingset, Nolan J (1993) Standard precipitation index (SPI) and methods of accessing rainfall variability. The Relationship of Drought Frequency and Duration to Time Scales. 8th Conference on Applied Climatology, Anaheim, 17–22 January 1993
- Moreland (1993), Burdon DJ (1985). Groundwater against drought in Africa. In *Hydrogeology in the Service of Man, Mémoires of the 18th Congress of the International Association of Hydrogeologists*. Cambridge. [http://iahs.info/redbooks/a154/iahs\\_154\\_02\\_0076.pdf](http://iahs.info/redbooks/a154/iahs_154_02_0076.pdf) Accessed 11 November 2010
- PANGIRE (2013) Plan D’Action National de Gestion Intégrée des Ressources en Eau: Etat des lieux du secteur
- Parry ML, Palutik JP, Van Der Lind PJ (2007) Water supply sanitation (WSS) in Moldova, climate change: impacts, adaptation and vulnerability. Contribution of working group II to the Intergovernmental Panel on Climate Change. Cambridge University Press, Cambridge
- Tsalefac M (2007) Variabilité climatique, crise économique et dynamique des milieux agraires sur les Hautes terres de l’ouest Cameroun. Thèse de Doctorat d’Etat de lettre et de science humaine, spécialité, option climatologie, Université de Yaoundé, 564p
- Tsalefac M, Ngoufor R (2007) Afrique Centrale, le Cameroun et les changements globaux
- Walsh R.P.D, Lawler D.M (1981) Methods of determining seasonality index and methods of accessing rainfall regimes. *Rainfall seasonality: Description, spatial patterns and change through time*
- Wilby RL (2006) Van Vliet and Zwolsman (2008) A framework for assessing uncertainties in climate change impacts, low-flow scenarios for river Thames, UK Sustainable land and water management policies and practices: a pathway to environmental sustainability in large irrigation systems. *Land Degrad Dev* 19:469–487

**Open Access** This chapter is licensed under the terms of the Creative Commons Attribution 4.0 International License (<http://creativecommons.org/licenses/by/4.0/>), which permits use, sharing, adaptation, distribution and reproduction in any medium or format, as long as you give appropriate credit to the original author(s) and the source, provide a link to the Creative Commons license and indicate if changes were made.

The images or other third party material in this chapter are included in the chapter’s Creative Commons license, unless indicated otherwise in a credit line to the material. If material is not included in the chapter’s Creative Commons license and your intended use is not permitted by statutory regulation or exceeds the permitted use, you will need to obtain permission directly from the copyright holder.







# Climate Change Adaptation: Implications for Food Security and Nutrition

# 39

Caroline Fadeke Ajilogba and Sue Walker

## Contents

Introduction .....	736
Climate Change and Reality .....	737
Climate Change Adaptation and Mitigation .....	739
Food Production and Climate Change .....	739
Climate Change Impact on Food Availability .....	742
Climate Change Impact on Food Accessibility .....	743
Climate Change Impact on Food Utilization .....	743
Climate Change Impact on Food System .....	744
Impact of Climate Change Adaptation on Food Security and Nutrition .....	744
Crop Diseases and Effects on Crop Yields .....	745
Climate Change Impact on the Spread of Plant and Animal Pests and Diseases .....	746
Climatic Conditions Favoring Crop Diseases: Wheat Rust Disease Example .....	746
Climatic Change Impact Postharvest .....	747
Climate Change Impact on Microbial Biodiversity .....	748
Ocean Acidification .....	749
Conclusions .....	749

This chapter was previously published non-open access with exclusive rights reserved by the Publisher. It has been changed retrospectively to open access under a CC BY 4.0 license and the copyright holder is “The Author(s)”. For further details, please see the license information at the end of the chapter.

C. F. Ajilogba

Division of Agrometeorology, Agricultural Research Council – Soil, Climate and Water,  
Pretoria, South Africa

e-mail: [ajilogbac@arc.agric.za](mailto:ajilogbac@arc.agric.za)

S. Walker (✉)

Division of Agrometeorology, Agricultural Research Council – Soil, Climate and Water,  
Pretoria, South Africa

Department of Soil, Crop and Climate Sciences, University of the Free State, Bloemfontein, South  
Africa

e-mail: [walkers@arc.agric.za](mailto:walkers@arc.agric.za)

© The Author(s) 2021

W. Leal Filho et al. (eds.), *African Handbook of Climate Change Adaptation*,  
[https://doi.org/10.1007/978-3-030-45106-6\\_142](https://doi.org/10.1007/978-3-030-45106-6_142)

735

Recommendations .....	749
Conflict of Interest .....	750
References .....	750

## Abstract

It is apparent that climate change affects every facet of life as no living organism lives outside of the universal environment (air, water, land), and all of these are affected by one or more climate or weather conditions. Climate affects agriculture and vice versa as they are deeply interconnected. The effect of climate change on agriculture goes a long way to increase or decrease food security and invariably food nutrition through its impacts on agricultural lands. This is because the more food insecurity there is, the more issues of undernutrition are observed.

This chapter studies the different ways climate and climate change affect crop production through the different sections of agriculture in terms of plant diseases and biocontrol, food production, livestock rearing, fish production, forestry, and microbial diversity. It goes further to look at the different ways nations and communities are adapting to climate change to mitigate the challenges of food insecurity and nutrition. Finally, some of the solutions that can be pilot tested at the community level, which can later be cascaded to national and regional levels, are also emphasized. Other recommendations that can become a research focus to forestall this threat are also highlighted and would be important in policy development.

## Keywords

Climate change · Environment · Food availability · Food production · Food security · Nutrition · Soil · Weather

## Introduction

Food security has been affected by a change in climate and weather conditions globally. Recently it is also obvious that food nutrition security needs to be addressed. Agriculture is important for food security in two ways: it produces the food people eat and (perhaps even more important) it provides the primary source of livelihood for 36% of the world's total workforce (ILO 2007). The Food and Agriculture Organization (FAO) of the United Nations (UN) defined food security at the World Food Summit in 1996 as “when all people, at all times have physical and economic access to sufficient, safe and nutritious food to meet their dietary needs and food preferences for an active and healthy life” (Food and Agriculture Organization 1996). Food security transcends food availability (production, distribution, and exchange) but also include how food is accessed (affordability, allocation and preference), utilized (food safety, nutrition, and social value) and also how it is distributed in the supply chain (food stability) (Ziervogel and Frayne 2011). This also means that it is not just about food but how available food is. And even when

it is available, communities and individuals might be food insecure if they are not able to access food either because of monetary incapacitation or because of lack of knowledge of where to acquire the food, based on their livelihoods and socioeconomic level. It could also be as a result of how safe the food is especially in terms of processes followed during food preparation (Ziervogel and Ericksen 2010).

Agriculture, forestry, and fisheries have all been affected by climate change, and they have contributed to the increase in greenhouse gas emissions, thus affecting climate change negatively. The solution to climate change also partly lies within this sector, if agriculture is able to mitigate climate change through reduction of greenhouse gas emission during sustainable agricultural practices (Al et al. 2008).

Adaptation to climate change can constitute a range of interventions across all levels from individuals to communities to regional and national level. As observed by Bierbaum et al. (2013), communities can initiate their climate adaptation efforts in numerous ways. For example, in the United States, some diverse strategies employed by different communities to combat the issue of climate change include:

- Focusing on internal operations
- Beginning with a sector that is particularly vulnerable to climate change
- Integrating climate change concerns into existing planning approaches
- Conducting a community-wide assessment

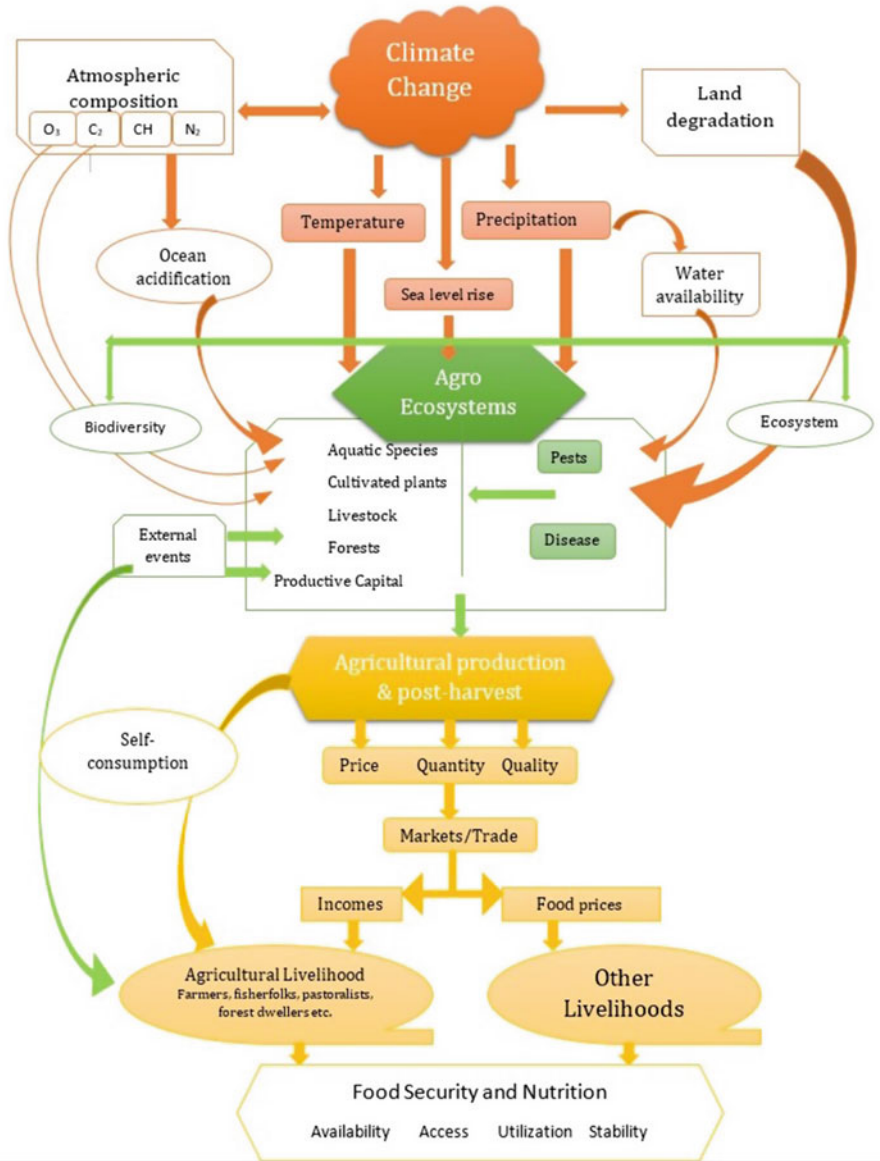
The results from these experiments with adaptation strategies demonstrate that there is no “one size fits all” adaptation process or adaptation action (Bierbaum and Stults 2013). This is quite important to note in adaptation plans; however, the information required and the approached to adaptation can be similar across regions and sectors. Therefore, strategies that encourage data and best practices sharing, practical approaches, collaborative, and integrative processes will be important in developing adaptation plans in different countries.

---

## Climate Change and Reality

Climate change occurs when changes in the Earth’s climate system result in new weather patterns that last for at least a few decades and maybe for millions of years. Effects of climate change are seen in the frequency and severity of extreme weather events including droughts, floods, new rainfall patterns, and heatwaves. Increases in temperature have led to an escalation in the distribution of weeds, pests, and diseases some of which are a threat to marine life, plants, animals, and humans. In the same vein, an increase in extreme weather events has led to soil erosion (by water and wind) and loss of arable land for forestry and agriculture.

Impact of climate change on food production cannot be overemphasized; it is enormous and felt more acutely in developing and the least developed nations (Fig. 1). Flooding and droughts have been observed to ruin crops and pastures already being cultivated on the fields. Losses due to floods and droughts between



**Fig. 1** The interrelatedness between climate change, food security and nutrition showing the impact of climate change on food security. (Adapted from FAO 2016)

2004 and 2014 have been estimated to be over 100 billion USD globally (Food and Agriculture Organization 2015; Brida et al. 2013).

Agriculture and fisheries are extremely climate dependent. Temperature and carbon dioxide (CO<sub>2</sub>) increases in some areas can increase some agricultural

productivity. Nevertheless, the higher demand for nutrients, soil moisture, water availability, and other requirements must also be met in order to realize these benefits. Changes in drought and flood frequency as well as intensity can present severe threats for farmers and ranchers and therefore threaten food safety (Ziska et al. 2016). In addition, warmer water temperatures are likely to trigger a change in the habitat ranges of many species of fish and shellfish, which may threaten ecosystems. Furthermore, climate change could make it harder to produce food and fish and raise livestock in the same way and in the same places as in the past (Chen 2015).

---

## Climate Change Adaptation and Mitigation

Adaptation to climate change is a way of responding to global climate change (also called “climatic change” or “anthropogenic climate change”). According to The Intergovernmental Panel on Climate Change (IPCC), adaptation is sequence of modifications to actual or expected climate and the impacts of the modification. Adaptation is aimed at mitigating or preventing harm or manipulating beneficial possibilities within human systems. Sometimes, the contributions of human beings enhance adaptations to these modifications and its impacts (IPCC 2014). This requires intentional efforts in the human environmental system to adapt behavioral patterns, lifestyles, and perceptions that can lower the risk to human lives and livelihoods, while mitigation involves coordinated actions to reduce long-term emissions of greenhouse gases (Al et al. 2008). In contrast, climate change mitigation means reducing greenhouse gas emissions and short-term sequestration and processing of coal and even more significantly by making infrastructural decisions that will reduce risk by reducing long-term emissions. While the entire food system is a producer of greenhouse gas emissions, still the most important component is primary production. Incentives are required to encourage producers, agribusinesses, and managers of biodiversity to follow good practices to mitigate climate change.

---

## Food Production and Climate Change

Climate change will affect food production and welfare of food animals (i.e., livestock, poultry, and fish) in several different ways. Consider the production of livestock that will probably be restricted by climate change as consumption of water by livestock is expected to increase by a factor of three. The need for arable land for pastures and feed production will increase because of a 70% increase in demand for agricultural products. Food safety issues also become important because around one-third of the world’s cereal harvest is used for animal feed (Rojas-Downing et al. 2017). Furthermore, 14.5% of global greenhouse gas (GHG) is produced by the livestock industry. The livestock sector will therefore be a key player in reducing GHG emissions and enhancing global food security in the future (Rojas-Downing et al. 2017; Gerber et al. 2013).

Climate change and competition for land together with water and food security are likely to adversely affect livestock production at a time when it is most wanted (Thornton 2010). The output efficiency of feed conversion ratios for food, dairy, and egg production could be felt as a result of losses due to climate change. Increasing temperatures can also lead to death of food animals, as was noted by the deaths of more than 30,000 dairy cows in California and also in reduction of the overall production of milk in 2006 (Pitesky et al. 2014). Temperature affects most of the critical factors for livestock production, such as water availability, weight gain (feed conversion ratio), reproduction (semen quality, cow calf efficiency), and general health. A combination of increases in temperature, CO<sub>2</sub>, and variability in precipitation influences the quantity, quality, and availability of forage and grain feed crops. Livestock diseases are affected primarily by an increase in the variation in temperature and precipitation (Thornton 2010).

Changes in land use, food production, animal production, manure, storage and transportation, and livestock all influence local and global weather patterns. Production of feed and manure releases CO<sub>2</sub>, nitrous oxide (N<sub>2</sub>O), and methane (CH<sub>4</sub>), thereby influencing climate change. Therefore, livestock production systems increase emissions of CH<sub>4</sub>. The production and transportation of animal products and improvements in land use contribute to increased CO<sub>2</sub> emissions. Research on the impact of climate change on livestock production is still minimal and need renewed attention (IPCC 2014).

Insects are ectotherms and are highly sensitive to their surrounding environmental conditions particularly the temperature; therefore temperature is a major factor affecting their reproduction (Kambrekar et al. 2015). This means increases in temperature for both edible and disease-causing insects could increase their reproductive cycle up to five cycles in a single year, which could affect farm food production negatively in terms of crop stress and yield loss. For beneficial insects, this increase in temperature will lead to increase in their metabolism (Kambrekar et al. 2015). Perhaps this provides an opportunity to develop new food systems based on insect production, either as feed for livestock and fish or directly for human consumption.

The possible effects of changing climate on insects could result in outbreaks, migration, change in biodiversity, species extinction, change in host shift, and emergence of new pests or biotypes. Due to the climate change, there is an increase in insect pest population, more outbreaks of insects, increased number of generations, as well as development of resistant biotypes (Moore and Allard 2008).

Fish plays an important role as a source of nutrients and micronutrients for human consumption, and fishing is a crucial food-producing sector and a source of livelihood for coastal farmers. Both fisheries and aquaculture make a significant contribution to food security and the livelihoods of millions of people as job creators, nutritious food providers, revenue generators, and economic growth through harvesting, processing, and marketing fish. Especially susceptible to climate change are small-scale fisherfolk and small-scale aquaculture. Their vulnerability is the function of both their location and their circumstances of vulnerability and disadvantage. Fishing and fishing communities are exposed to extreme climatic conditions and natural hazards, such as hurricanes, cyclones, sea level rise, ocean

acidification, flooding, and coastal erosion, as they are mostly situated on the coastline. Millions of people living in the lowlands of coastal regions and the floodplains cannot escape regular flooding. Climate change affects living conditions as well as physical well-being of humans across many agro-forest ecosystems of the world (FAO 2016).

Forests are a climate-stabilizing force. They control habitats, preserve biodiversity, play an integral role in the carbon cycle, improve living conditions, and provide goods and services that can boost sustainable growth (Bonan 2008). A forest's position in climate change is that it both causes and mitigates greenhouse emissions; therefore, there are both pros and cons. Impacts of climate change on forests result from variations in atmospheric CO<sub>2</sub> concentration, and shifts in temperature and precipitation regimes, as well as an increase in climate variability reflected by increasing frequency and severity of extreme events. Change in climate will affect tree photosynthesis, rates of growth, leaf phenology, seed production, and cycling of nutrients (van der Meer et al. 2002). In some regions, forest form a vital resource for the community. For example, tropical forests cover about one third of the Kafa highland region of Ethiopia where a multiple tenure system exists for the utilization of the forest resources (Zewdie 2003). These include sharecropping and allocation of trees to sons when they come of age. However, the beekeeping and wood processing skills also need to pass from one generation to the next to maintain sustainable livelihoods (Zewdie 2003). Therefore, climate change effects on such forests will have a major impact on the livelihoods of the people.

The land management sector, the second largest driver of greenhouse gas emissions after the energy sector, accounts for around 25% of global emissions. Around half of these come from deforestation and habitat destruction (5–10 Gt CO<sub>2</sub>e per year). Planting of forests and commercial plantations are among the most important strategies to address climate change effects. It is estimated that 2.6 billion tons of carbon dioxide, which is one-third of CO<sub>2</sub> from burning fossil fuels, is absorbed annually by forests. Projections show that there are nearly two billion square kilometers of worldwide degraded land – an area the size of South America – that can open up opportunities for restoration. Therefore, forest growth and preservation is an important solution to address the impact of climate change.

There are four major strategies available to mitigate carbon emissions through forestry activities:

- By reforestation (Bierbaum et al. 2013)
- Increasing the carbon content of natural forests on both stand and landscape scales
- Expansion of the use of forest products that replace CO<sub>2</sub> emissions from fossil fuels sustainably
- Reducing deforestation and degradation emissions

Climate also adversely affects the production of food crops that are highly sensitive to climate parameters. Long-term trends in average rainfall and temperature, interannual variability in climate, shocks during specific phenological stages,

and extreme weather events affect food production (IPCC 2012). Some crops are more tolerant to certain stress types than others, and different stress types affect each crop species in different ways at each phenological development stage (Simpson 2017). Even though, crop yields are expected to decline under climatic conditions in the future, crop yields are already being affected as indicated by recent research (Ray et al. 2019).

As climate changes, crop production strategies must change also. There will always be some uncertainty associated with modeling the complex relationships between agricultural yields and future climate scenarios.

## Climate Change Impact on Food Availability

Food availability is determined by the physical quantities of food that are produced, stored, processed, distributed, and exchanged (Al et al. 2008). Food production is affected by climate especially in regions where biochemical processes are being influenced by climate change. Some of these influences could be positive, negative, or even neutral (Allen Jr 1991). Location is a determinant of how the effect of climate change will be experienced in different regions (Leff et al. 2004). In temperate regions where elevated levels of CO<sub>2</sub> will increase plant growth and development, greenhouse fertilization effect is beneficial so crop yields will also increase. Such increase is observed to be as high as 0–10% increase in crops with very high photosynthetic efficiency, while those crops with lower efficiency have higher increase from between 10% and 25%. In such scenarios, the assumption is that the level of CO<sub>2</sub> in the atmosphere will increase to 550 parts per million (Tubiello et al. 2007; IPCC 2007). In some cases, increase in temperature between 1 °C and 3 °C is beneficial to plants in temperate regions; however, in tropical and seasonally dry regions, the impact is negative on crops especially cereals that are already growing near to their optimal temperature regime. Nevertheless, the impact is negative on all crops when the increase in mean temperature is more than 3 °C (IPCC 2007).

Such temperature increase will also impact livestock production as the growth of feed crops is also compromised and become an indirect effect on livestock production (Porter and Semenov 2005). Direct effects are related to exposure to solar radiation that then affects the exchange of heat between the animal and the environment (Rust and Rust 2013). This is critical, as many livestock breeds are not tolerant of high temperatures (Rust and Rust 2013). Forage production from rangelands in Africa is sensitive to changes in climate and will have a substantial impact on the livelihoods of more than 180 million people who raise livestock on rangelands (Boone et al. 2018). Climate effects on forage quality that depends on nutrient composition and affects digestibility, partitioning of metabolized products in the digestive tract, and intake of forage by animals will strongly affect animal performance.

Some drastic changes in the farming system sometimes have to be introduced, such as a change from sheep and cattle to goats, as they are the only domesticated



animals with a versatile ability to adapt to a changing climate more readily than any other ruminants. Generally, goats are less affected by the harsh hot dry climates compared with other ruminants. Some of their ability to adapt is due to their habit of browsing together with the anatomical advantage of the upper lips. Therefore, goats can thrive well with limited feedstuffs, especially in arid and semiarid regions (Pragna et al. 2018). Another advantage is that during feed scarcity, goats can reduce their metabolic processes to conserve energy resource (Yadav et al. 2013). Therefore, they provide a continued supply of meat despite increases in temperature and frequencies of drought.

### **Climate Change Impact on Food Accessibility**

“Climate change is becoming something we can taste” (Little 2019). According to Little (2019), this is the age of diversity and accessibility of food. Food accessibility is a function of being able to maintain and manage what one is entitled to, which is defined as the collection of assets (including legal, political, economic, and social) needed by a person to gain access to food (Sen 1989, cited in FAO 2003, Sage 2014).

Food accessibility refers to ability to own food, distribute it, and make food choices which allows people to turn their hunger effectively into demand (Sage 2014). Since food accessibility focuses on the power of households/individuals to be able to spend money, and the group dynamics of access to food, poverty, and vulnerability are key functions of it (Ziervogel and Frayne 2011).

Households have been observed not to grow their foods independently but either buy, trade, or exchange them (Du Toit and Ziervogel 2004). The ability to acquire food by households can be impacted by climate as it influences either the job opportunities or the availability of such foods may influence non-availability of some foods leading to increase in price, which could also make such foods unaffordable, thereby impacting on individual’s nutrition and health. When there is an increase in price, low-income earning families are at the receiving end, so when they cannot purchase such foods, they either eat less preferred foods or reduce quantities of food eaten, making food prices very important to food security (Pretty et al. 2005).

### **Climate Change Impact on Food Utilization**

Food utilization refers to how food is used and how individuals can obtain vital nutrients from the food they eat. This includes the nutritional benefits of the food, the nature and method of processing the food, and the way the society views each food that also determines when if and when such foods should be eaten. Also included are the knowledge of the quality and health of the food, which determine if there would be nutrient loss or the susceptibility of the food-to-food-borne diseases if below standard (FAO 2008).

When there is insecurity of food, dietary diversity is reduced, and this could lead to non-availability of nutritious food that form basis of balanced diet of the populace. This scarcity could be as a result of water scarcity, drought, or labor from climate change and variability. This impact of climate change on food utilization is indirect because its effect is ultimately felt on the effect of income and capacity to purchase a diversity of foods.

The way the food is utilized by the body affects the nutritional status of individuals and informs the susceptibility of such individuals to diseases. This is observed as changes in human health that has been affected by new disease patterns created as a result of the response of different pests and vectors to climate change. As climate change increases, there are more waterborne infections and diseases in areas that are prone to flooding. This is because there will be increase in the population of pests and vectors, and new diseases will emerge, which can affect plant's growth and ultimately the food chain. As a result of the diseases, people's physiological capacity to obtain necessary nutrients from the foods consumed will be affected. Therefore, they can become nutritional food insecure despite the supply of food being sufficient (FAO 2008).

### **Climate Change Impact on Food System**

Yields of crops particularly crops grown on an annual basis will fluctuate as a result of the change in rainfall and temperature patterns; these changes will affect the continuous supply of such crops (Al et al. 2008; Ali et al. 2014). Droughts and floods will become more frequent because of climate change, and this will adversely affect stability and availability of food leading to food security. Therefore, in local communities, the food system will be adversely affected by the timing and amount of rainfall in different seasons because most agricultural systems in such communities are rainfed (Al et al. 2008; Ali et al. 2014).

Grain reserves are used to mitigate for crop failures in disaster situations and to sustain food aid programs for displaced persons and refugees. For grain to be kept as reserves, they have to be properly stored or preserved correctly. When humidity and temperature increase because of climate change, some areas become unfit to store the grains, and additional funding will be required to store or preserve them. Invariably because of the higher cost, the ability of many underdeveloped countries to maintain sufficient grain reserves is limited or grain reserves can be inadequate to respond to natural or human disaster (Al et al. 2008; Edame et al. 2011).

---

### **Impact of Climate Change Adaptation on Food Security and Nutrition**

A significant effect of global climate change is the altering of global rainfall patterns, with certain effects on agriculture (Ali et al. 2014). Climate change will have variable impacts on agriculture based on multiple factors including changes in temperature, precipitation, and humidity (Pitesky et al. 2014). Rainfed

**Table 1** The impact of climate change on food security

Climate change	Impacts
Increase in average temperature	Reduced quantity and reliability of agricultural yield
	Increased heat stress in livestock
	Destruction of crops or lowering crop productivity
	Decline in certain fish stocks due to increased sea temperature
Change in amount of rainfall	Reduced water availability for crop and livestock
	Heavy reliance on irrigation
	Poor quality of crops due to deteriorating water quality
Increased severity of drought	Decreased crop yield
	Increased probability of fire
Increased intensity of extreme events	Soil erosion
	Increased land degradation and desertification
	Inability to cultivate land
	Damage to crops and food stores

Source: Masipa (2017)

agriculture constitutes 80% of global agriculture. Many of the 852 million poor people in the world live in parts of Asia and Africa that depend on rainfall to cultivate food crops. Climate change will modify the components of the water balance, namely, rainfall, evaporation, runoff, and soil moisture storage. This means that the full crop water requirement will not be satisfied in such a growing season. Extended drought can cause the failure of small and marginal farms with resultant economic, political, and social disruption, more than is currently observed (Table 1).

## Crop Diseases and Effects on Crop Yields

Crop diseases are very important because of their economic impact (Esler et al. 2012), and how they are managed can have a large influence on agricultural productivity (Savary et al. 2012; Carroll et al. 2017). The growing population of the world and the overall reduction in global production of staples such as rice and wheat due to climate change (Ray et al. 2019) are two fundamental challenges that need to be tackled, with crop protection against diseases having an obvious role to play in bringing solutions to these challenges. Crop diseases affect the life cycles of any growing plant. They affect crop production from seedling stage through budding, flowering, and fruiting until harvesting. Crop diseases that occur during seedling and budding stages will in most cases cause the death of the plants as the growing point is damaged. These deaths lead to complete crop failure and high losses. In addition, losses at the time of harvest in most cases cause the reduction in yield in terms of size and quality and thus also a reduction in overall production (Savary et al. 2012). Therefore, loss of crops caused by pests, infections, or even weeds or animal attacks is a risk to farmers, their family or household income, and food security worldwide. Losses of crops due to yield reduction can be defined

qualitatively and quantitatively (Cerda et al. 2017) in terms of the reduction in the value of the crop or the financial gain from crop sales.

In order to assess crop loss based on decrease in yield of crop, the variance between the real yield ( $Y$ ) and the attainable yield that can be obtained ( $Y_a$ ) is taken into consideration as  $Y_a - Y$  according to the definition of crop loss by Esker et al. (2012). The attainable yield can be achieved based on the different climatic and environmental conditions at specific locations without the impact of pests, pathogens, and weeds as well as other influences that may decrease yields within available production techniques. These climatic conditions among others include temperature, rainfall, solar radiation, and soil composition. The influence of pests, diseases, and other limiting factors in the actual sense and in real-life situation is reflected on the real yield (Esker et al. 2012; Savary et al. 2006).

Plant diseases are not just important because of their impact on crop yield, which is quantitative, but also their impact on the quality of the grain or product. As crops are attacked by disease pathogens, toxins are released into these crop which reduces the quality of the crop and can also cause infection in both animals and humans (Gururani et al. 2012).

## **Climate Change Impact on the Spread of Plant and Animal Pests and Diseases**

Climate change can influence trends in seasons and the prevalence of disease-causing organisms and vectors and therefore also the use of herbicides and fungicides (Boxall et al. 2008). These reactions will vary among crops and geographical location. As a result of climate variability, the use of pesticide is expected to increase in the United States (Chen and McCarl 2001). Nevertheless, the estimated effects of climate change on pesticide use are a function of the type of crop and the geographical location. For example, from the United States, in Kansas and Colorado, the projected use of pesticides on wheat increased by 14% and decreased by 10%, respectively, while that of Illinois differed based on which crops was planted with increases on corn and decreases on soybean by 10% and 3%, respectively (Harrus and Baneth 2005). This shows that when there is an increase in temperature due to climate variability, there could be an outbreak of pests, pathogens, and/or vectors and their hosts (Lake et al. 2012). This outbreak could also lead to the use of more biocides and veterinary medicines in livestock management and eventual resurgence of antibiotic-resistant pathogens in both animal and human populations (Lake et al. 2012; Kemper 2008).

## **Climatic Conditions Favoring Crop Diseases: Wheat Rust Disease Example**

As climate changes, the way disease pathogens adapt to the environment also changes leading to new disease occurrences (Fig. 1). For example, it was observed

that warmer weather conditions favor the establishment and progress of wheat stem rust infection (Saunders et al. 2019). In certain regions of the world, during early growing season, high temperatures are experienced. This can cause the wheat plants that mature early to be at risk of the stem rust infection due to not being able to resist the buildup of the fungal inoculum (Saunders et al. 2019). This is because stem rust mainly needs warmer conditions for infection (Saunders et al. 2019). For example, in Germany in 2013, winter wheat production was hindered by a wet winter with low temperatures, and early warm summer temperatures led stem rust infection afterward. (Olivera Firpo et al. 2017).

## Climatic Change Impact Postharvest

Over 80% of attainable yield of cotton and over 50% for other crops would be affected by pests and diseases with resulting effects on humankind. These effects which also include spoilage during postharvest and storage are felt more in resource-poor regions (Oerke 2006). It is estimated that an average of 13% of global harvest is lost to pests and diseases, and an average of 9% to postharvest losses especially in developing countries that lack the infrastructures to store harvested crops (Oerke 2006). In some cases, such infrastructures are destroyed due to climate change such as storms, hurricanes, and tornadoes (Agrios 2005). Also, destruction caused as a result of plant diseases can be far reaching and alter the course of society and political history (Chakraborty and Newton 2011).

Storms have led to loss of crops, livestock, and infrastructure and increase in the cost of grains as a result of increase in production cost. This increase also leads to lack of resource power of the minority poor in gaining access to food and invariably increases food insecurity.

The production and quality of essential food crops are hindered by plant diseases, which also affect food quality and safety. Besides reducing yield, they have significant effects on human and animal health. As a result of global climate change, the challenge of mycotoxins and pesticide residues are serious safety issues to be mitigated (Miraglia et al. 2009). Mycotoxins are important as they cause serious health issues because of the interactions between fungus and plant cells, which are also stimulated by conducive weather conditions and the soil type. In some areas like the United States, increases in temperature increased the production of mycotoxins such as aflatoxins, while in other regions like Australia, increase in temperature could be effective in the reduction of fungal growth and invariable mycotoxin production (Russell et al. 2010; Lake et al. 2012).

Climate change may affect the transport of pathogens and chemicals into food from flooding and wind bearing aerosols from contaminated environments and may change the composition of the transported materials (Plumlee et al. 2005; Boxall et al. 2008). This is also observed in the transportation of food crops from the farm before it is consumed where higher temperatures can favor the growth and replication of bacterial population like *Salmonella* spp. leading to food poisoning (Lake et al. 2012).

## Climate Change Impact on Microbial Biodiversity

Climate change affects the diversity and types of macro- and microorganisms globally. Biodiversity can be measured at three levels, that is, genetic, species, and ecosystem level. Agriculture and the livelihood of most people globally depend on the genetic diversity of species and the types of species within the ecosystem (ten Kate and Laird 1999). Based on the adverse effect of chemicals in agriculture, and on human health and the environment, the use of chemicals is gradually being phased out to accommodate other techniques and technologies that can control plants and animal's pests and diseases and reduce adverse effects currently experienced by living things and the environment.

In order to achieve agricultural biodiversity, diseases and pests must be dealt with since they are one of the most deadly blows to food security. Seven thousand plant species and several thousand animal species have been used historically for human nutrition and health requirements (Toledo and Burlingame 2006). However, since the 1900s, only 12 crops and 14 animal species now provide most of the world's food, so there is a very real threat to global biodiversity and also food security.

Soil biological management techniques can improve crop yield and quality, especially through controlling pests and diseases and enhancing plant growth. Soil biodiversity determines the resource use efficiency, as well as the sustainability and resilience of low-input agro-ecological systems, which ensure the food security of much of the world's population, especially the poor (Paoletti et al. 2000). Part of the value placed on soil biodiversity is seen in biological control of pests and pathogens that improve plant health and thus also crop production and invariably improving local food security.

### Biocontrol of Plant Diseases

Biocontrol is one of the integrated disease management practices that help to reduce yield loss of crops (Thurman et al. 2017). It is the control of plant diseases by applying living biological agents or exudates from such biological agents to the plants. The application could be via foliar application to the leaves or via the roots or seed inoculation prior to planting. Most biocontrol agents (BCA) are either from the bacterial or fungal families with a few from the viral and nematodal families (O'Brien 2017; Ajilogba and Babalola 2019). Some BCAs are either rhizospheric or endospheric microbes, as they attack the pathogens using different modes including phosphate solubilization, antagonism, and hydrogen cyanide production (Ajilogba and Babalola 2016). One important fact about biocontrol is that they are specific to pathogens and sometimes to crops making them very effective. Their effectiveness is also determined by the mode of inoculation, duration of inoculation, time of inoculation, and whether they are applied singly or in a mixture. Climate change also influences biocontrol because changes in the environment affect different dimension of agricultural production. In the context of climate change, with increasing temperature and variable rainfall patterns, changes are also observed in the cycling of nutrients and amount of soil water as a result of decreases in rainfall. The rainfall pattern also affects the patterns of incidence of plant pests, pathogens, and diseases, and invariably food production and security are ultimately affected (Lin 2011; Fuhrer 2003; Jones and Thornton 2003).

---

## Ocean Acidification

This is more of a recent phenomenon with climate change. It is one of the potentially most harmful and deleterious effects of climate change. Over 30% of carbon dioxide produced in the atmosphere is absorbed by sea and oceans leading to the production of acids when carbon dioxide mixes with water. Most marine creatures cannot survive at low pH. Fish production is at a risk both directly and indirectly. The basic producers in the food chain such as planktons are also at risk, and this creates a reduction in food available to the large fish that consume them directly such as tuna, making them at risk of starving. Increasing acidity could harm shellfish by weakening their shells, which are created by removing calcium from seawater (Doney et al. 2014). Acidification also threatens the structures of sensitive ecosystems upon which some fish and shellfish rely (Hatfield et al. 2014; Ziska et al. 2016). Fish is not only a source of proteins and healthy fats but also a unique source of essential nutrients, including long-chain omega-3 fatty acids, iodine, vitamin D, and calcium. Therefore, the effects on climate change on the acidity of the oceans will cause a decrease in annual fish caught and processed at a good source of protein for humankind. Particularly in the Asian-Pacific region, fish protein forms a vital component of the diet (Needham and Funge-Smith 2014). It is not only true for small island states, with their strong dependence upon fisheries; it was also found in continental Asian countries even far inland due to large rivers, waterways, and many rice paddies. Therefore, the importance of fish in the diet should not be overlooked in discussions on nutrition and food security and expected changes under the climate change conditions.

---

## Conclusions

Climate change is a reality, both at global and the regional scales. The magnitude of change is still uncertain and highly variable, as is the timing of the change. However, the severe nature of the impacts which climate change could have on all sectors of Africa's economy is becoming clear. The ability of individuals and communities to adapt to climate change depends on their vulnerability, exposure, and adaptive capacity. In turn, this is related to their financial and social capital, such as social networks and community cohesion.

---

## Recommendations

Adaptation is a key factor that will shape the future severity of climate change impacts on food production; therefore, consideration of additional food such as underutilized crops and/or neglected foods can play a role in increasing food and nutrition supply.

There is, therefore, a need for an integrated policy approach to protect the arable land.

Further assistance needs to be given to small-scale farmers in rural areas in order to strengthen their crop production.

The restoration of forestation should be encouraged in order to make adequate use of forests to address climate change.

Globally and whenever necessary, nations should specifically relate their mitigation and adaptation initiatives to their policy decisions on environmental sustainability in agriculture industry. These policies should both be holistic and anti-poor in order to bridge the gap on the unequal effect that climate change may have on the different agricultural industries.

Consideration should be given to the economic, institutional, and social impacts of climate change by making policies that will target the global poor and vulnerable especially gender based in order to help them create communities that are resilient and robust.

Disasters caused by climate change in agriculture communities demand immediate emergency relief response and comprehensive facilities such as shelters especially in the animal farming communities. Such developments frequently involve initiatives that will provide opportunities for people to develop societies and cooperatives that are stronger and more productive and thereby becoming more self-reliant.

Adaptation and mitigation measures and strategies for climate change need to be designed and implemented through widely understood processes. Affected agricultural communities, organizations, the poor, and other vulnerable groups must be allowed to participate as stakeholders.

Global and national relevant indicators to ensure the participation of the poor and vulnerable should be developed; this could be done by keeping gender-stratified data to predict and determine the impacts of climate change on them and also their geographic locations.

Other recommendations include availability of suitable technology and decision support tools, removal of institutional barriers, and need for basic research to increase knowledge and information.

---

## Conflict of Interest

Authors have no conflicts of interest to report.

**Acknowledgments** The authors want to thank the National Research Foundation for the grant to the first author and the Agricultural Research Council – Soil, Climate, Water (ARC-SCW) for logistics.

---

## References

- Agrios G (2005) Plant pathology, 5th edn. Elsevier Academic Press, London
- Ajillogba CF, Babalola OO (2016) RAPD profiling of *Bacillus* spp. with PGPR potential and their effects on mineral composition of tomatoes. *J Hum Ecol* 56(1–2):42–54



- Ajillogba CF, Babalola OO (2019) GC–MS analysis of volatile organic compounds from Bambara groundnut rhizobacteria and their antibacterial properties. *World J Microbiol Biotechnol* 35(6):83
- Al W, Orki G, Clima O (2008) Climate change and food security: a framework document. FAO, Rome
- Ali F, Thaver I, Khan SA (2014) Assessment of dietary diversity and nutritional status of pregnant women in Islamabad, Pakistan. *J Ayub Med Coll Abbottabad* 26(4):506–509
- Allen LH Jr (1991) Effects of increasing carbon dioxide levels and climate change on plant growth, evapotranspiration, and water resources. In: *Managing water resources in the west under conditions of climate uncertainty*. Proceedings of a colloquium, 14–16 Nov 1990, Scottsdale, AZ. National Academy Press, Washington, DC, pp 101–147
- Bierbaum R, Stults M (2013) Adaptation to climate change. *Mich J Sustain* 1. <https://doi.org/10.3998/mjs.12333712.0001.004>
- Bierbaum R, Smith J, Lee A, Blair M, Carter L, Stuart Chapin F III, Fleming P, Ruffo S, McNeeley S, Stults M, Wasley E, Verduzco L (2013) A comprehensive review of adaptation in the United States: more than before, but less than needed. *Mitig Adapt Strateg Glob Chang* 18(13):361–406. <https://doi.org/10.1007/s11027-012-9423-1>
- Bonan GB (2008) Forests and climate change: forcings, feedbacks, and the climate benefits of forests. *Science* 320(5882):1444–1449
- Boone RB, Conant RT, Sircely J, Thornton PK, Herrero M (2018) Climate change impacts on selected global rangeland ecosystem services. *Glob change Biol* 24(3):1382–1393
- Boxall AB, Hardy A, Beulke S, Boucard T, Burgin L, Falloon PD, Haygarth PM, Hutchinson T, Kovats RS, Leonardi G (2008) Impacts of climate change on indirect human exposure to pathogens and chemicals from agriculture. *Environ Health Perspect* 117(4):508–514
- Brida A-B, Owiyo T, Sokona Y (2013) Loss and damage from the double blow of flood and drought in Mozambique. *Int J Glob Warming* 5(4):514–531
- Carroll CL, Carter CA, Goodhue RE, Lawell C-Y (2017) Crop disease and agricultural productivity. National Bureau of Economic Research, Cambridge, MA
- Cerda R, Avelino J, Gary C, Tixier P, Lechevallier E, Allin C (2017) Primary and secondary yield losses caused by pests and diseases: assessment and modeling in coffee. *PLoS One* 12(1): e0169133
- Chakraborty S, Newton AC (2011) Climate change, plant diseases and food security: an overview. *Plant Pathol* 60(1):2–14
- Chen X (2015) Climate change: causes, impacts and adaptation. Project supported by Governor State University Intellectual Life Grant, pp 1–9
- Chen C-C, McCarl BA (2001) Pesticide usage as influenced by climate: a statistical investigation. *Clim Chang* 50(1–2):475–487
- Doney S, Rosenberg AA, Alexander M, Chavez F, Harvell CD, Hofmann G, Orbach M, Ruckelshaus M (2014) Oceans and marine resources. In: *Climate change impacts in the United States. The third national climate assessment*. U.S. Global Change Research Program, Washington, DC. <https://doi.org/10.7930/J0RF5RZW>
- Du Toit A, Ziervogel G (2004) Vulnerability and food insecurity: background concepts for informing the development of a national FIVIMS for South Africa. Background paper for FIVIMS-ZA consortium. <http://www.agis.agric.za/agisweb/agis.html>
- Edame EG, Ekpenyong AB, Fonta WM, Duru EJC (2011) Climate change, food security and agricultural productivity in Africa: issues and policy directions. *Int J Humanit Soc Sci* 1(21):205
- Esker PD, Savary S, McRoberts N (2012) Crop loss analysis and global food supply: focusing now on required harvests. *CAB Rev* 7(052):1–14
- FAO (2003) Focus on Food Insecurity and Vulnerability – A review of the UN System Common Country Assessments and World Bank Poverty Reduction Strategy Papers. FIVIMS Secretariat and Wageningen University and Research Centre. <https://www.fao.org/DOCREP/006/Y5095E/Y5095E00.htm>
- FAO (2008) Climate change and food security: a framework document. Food and Agricultural Organization of United Nation, Rome, Italy
- Food and Agriculture Organization (FAO) (1996) Rome Declaration on world food security. FAO, Rome

- Food and Agriculture Organization (FAO) (2015) The impact of natural hazards and disasters on agriculture and food security and nutrition: a call for action to build resilient livelihoods. Food and Agriculture Organization of the United Nations, Rome
- Food and Agriculture Organization (FAO) (2016) Climate change and food security: risks and responses. Food and Agriculture Organization of the United Nations, Rome
- Fuhrer J (2003) Agroecosystem responses to combinations of elevated CO<sub>2</sub>, ozone, and global climate change. *Agric Ecosyst Environ* 97(1–3):1–20
- Gerber PJ, Steinfeld H, Henderson B, Mottet A, Opio C, Dijkman J, Falcucci A, Tempio G (2013) Tackling climate change through livestock: a global assessment of emissions and mitigation opportunities. FAO, Rome
- Gururani MA, Venkatesh J, Upadhyaya CP, Nookaraju A, Pandey SK, Park SW (2012) Plant disease resistance genes: current status and future directions. *Physiol Mol Plant Pathol* 78:51–65
- Harrus S, Baneth G (2005) Drivers for the emergence and re-emergence of vector-borne protozoal and bacterial diseases. *Int J Parasitol* 35(11–12):1309–1318
- Hatfield J, Takle G, Grotjahn R, Holden P, Izaurrealde RC, Mader T, Marshall E, Liverman D (2014) Agriculture. In: Climate change impacts in the United States. The third national climate assessment. U.S. Global Change Research Program, Washington, DC
- ILO (2007) Employment by sector. In: Key indicators of the labour market (KILM), 5th edn. ILO, Geneva
- IPCC (2007) The physical science basis. Contribution of working group I to the fourth assessment report of the Intergovernmental Panel on Climate Change. Cambridge University Press, Cambridge, UK. 996pp
- IPCC (2012) Managing the risks of extreme events and disasters to advance climate change adaptation. In: CB Field, V Barros, TF Stocker, et al., editors. A Special Report of Working Groups I and II of the Intergovernmental Panel on Climate Change. Cambridge University Press, Cambridge, NY, USA
- IPCC (2014) Climate change 2014, impacts, adaptation, and vulnerability, Part A: global and sectoral aspects, working group II contribution to the fifth assessment report of the Intergovernmental Panel on Climate Change. Cambridge University Press, Cambridge, UK
- Jones PG, Thornton PK (2003) The potential impacts of climate change on maize production in Africa and Latin America in 2055. *Glob Environ Chang* 13(1):51–59
- Kambrekar D, Guledagudda S, Mohankumar A (2015) Impact of climate change on insect pests and their natural enemies. *Karnataka J Agric Sci* 28:814–816
- ten Kate K, Laird SA (1999) The commercial use of biodiversity: access to genetic resources and benefit-sharing. Earthscan, London
- Kemper N (2008) Veterinary antibiotics in the aquatic and terrestrial environment. *Ecol Indic* 8(1):1–13
- Lake IR, Hooper L, Abdelhamid A, Bentham G, Boxall ABA, Draper A, Fairweather-Tait S, Hulme M, Hunter PR, Nichols G, Waldron KW (2012) Climate change and food security: health impacts in developed countries. *Environ Health Perspect* 120(11):1520–1526. <https://doi.org/10.1289/ehp.1104424>
- Leff B, Ramankutty N, Foley JA (2004) Geographic distribution of major crops across the world. *Glob Biogeochem Cycles* 18(1):GB1009. <https://doi.org/10.1029/2003GB002108>
- Lin BB (2011) Resilience in agriculture through crop diversification: adaptive management for environmental change. *Bioscience* 61(3):183–193
- Little A (2019) The fate of food what we'll eat in a bigger, hotter, smarter world. *Libr J* 144(5):138
- Masipa TS (2017) The impact of climate change on food security in South Africa: current realities and challenges ahead. *Jamba* 9(1):1–7
- Miraglia M, Marvin H, Kleter G, Battilani P, Brera C, Coni E, Cubadda F, Croci L, De Santis B, Dekkers S (2009) Climate change and food safety: an emerging issue with special focus on Europe. *Food Chem Toxicol* 47(5):1009–1021
- Moore B, Allard G (2008) Climate change impacts on forest health: insect pests, diseases and invasive alien species. In: International conference on adaptation of forests and forest

- management to changing climate with emphasis on forest health: a review of science, policies and practices, p 170
- Needham S, Funge-Smith SJ (2014) The consumption of fish and fish products in the Asia-Pacific region based on household surveys. FAO Regional Office for Asia and the Pacific, Bangkok, Thailand. RAP Publication 2015/12. 87pp
- O'Brien PA (2017) Biological control of plant diseases. *Australas Plant Pathol* 46(4):293–304
- Oerke E-C (2006) Crop losses to pests. *J Agric Sci* 144(1):31–43
- Olivera Firpo P, Newcomb M, Flath K, Sommerfeldt-Impe N, Szabo L, Carter M, Luster D, Jin Y (2017) Characterization of *Puccinia graminis* f. sp. *tritici* isolates derived from an unusual wheat stem rust outbreak in Germany in 2013. *Plant Pathol* 66(8):1258–1266
- Paoletti MG, Dufour DL, Cerda H, Torres F, Pizzoferrato L, Pimentel D (2000) The importance of leaf-and litter-feeding invertebrates as sources of animal protein for the Amazonian Amerindians. *Proceedings of the Royal Society of London. Series B: Biol Sci* 267(1459):2247–2252
- Pitesky M, Gunasekara A, Cook C, Mitloehner F (2014) Adaptation of agricultural and food systems to a changing climate and increasing urbanization. *Curr Sustain Renew Energy Rep* 1:43. <https://doi.org/10.1007/s40518-014-0006-5>
- Plumlee GS, Foreman WT, Griffin DW, Lovelace JK, Meeker GP, Demas CR (2005) Characterization of flood sediments from hurricanes Katrina and Rita and potential implications for human health and the environment. In: *Science and the storms: the USGS response to the hurricanes of 2005*. US Geological Survey, Denver, pp 245–256
- Porter JR, Semenov MA (2005) Crop responses to climatic variation. *Philos Trans R Soc B Biol Sci* 360(1463):2021–2035
- Pragna P, Chauhan SS, Sejjan V, Leury BJ, Dunshea FR (2018) Climate change and goat production: Enteric methane emission and its mitigation. *Animals* 8(12):235. <https://doi.org/10.3390/ani8120235>
- Pretty JN, Ball AS, Lang T, Morison JI (2005) Farm costs and food miles: an assessment of the full cost of the UK weekly food basket. *Food Policy* 30(1):1–19
- Ray D, West PC, Clark M, Gerber JS, Prishchepov AV, Chatterjee S (2019) Climate change has likely already affected global food production. *PLoS One* 14(5):e0217148. <https://doi.org/10.1371/journal.pone.0217148>
- Rojas-Downing MM, Nejadhashemi AP, Harrigan T, Woznicki SA (2017) Climate change and livestock: impacts, adaptation, and mitigation. *Clim Risk Manag* 16:145–163
- Russell R, Patterson M, Lima N (2010) How will climate change affect mycotoxins in food? *Food Res Int* 43:1902–1914
- Rust JM, Rust T (2013) Climate change and livestock production: A review with emphasis on Africa. *S Afr J Anim Sci* 43:255–267
- Sage C (2014) Impacts of climate change on food accessibility. In *Handbook of Global Environmental Change* Springer Science + Business Media, pp 709–715
- Saunders DG, Pretorius ZA, Hovmøller MS (2019) Tackling the re-emergence of wheat stem rust in Western Europe. *Commun Biol* 2(1):51
- Savary S, Teng PS, Willocquet L, Nutter FW Jr (2006) Quantification and modeling of crop losses: a review of purposes. *Annu Rev Phytopathol* 44:89–112
- Savary S, Ficke A, Aubertot JN, Hollier C (2012) Crop losses due to diseases and their implications for global food production losses and food security. *Food Secur* 4(4):1–19
- Simpson BM (2017) Preparing smallholder farm families to adapt to climate change. *Managing crop resources. Pocket guide 2*. Catholic Relief Services, Baltimore
- Thornton PK (2010) Livestock production: recent trends, future prospects. *Philos Trans R Soc Lond B Biol Sci* 365(1554):2853–2867. <https://doi.org/10.1098/rstb.2010.0134>
- Thurman JH, Crowder DW, Northfield, TD (2017) Biological control agents in the Anthropocene: current risks and future options. *Curr Opin Insect Sci* 23:59–64. <https://doi.org/10.1016/j.cois.2017.07.006>
- Toledo A, Burlingame B (2006) Biodiversity and nutrition; a common path toward global food security and sustainable development. *J Food Compos Anal* 19:477–483

- Tubiello FN, Amthor JS, Boote KJ, Donatelli M, Easterling W, Fischer G, Gifford RM, Howden M, Reilly J, Rosenzweig C (2007) Crop response to elevated CO<sub>2</sub> and world food supply: a comment on “Food for thought. . .” by Long et al., *Science* 312: 1918–1921, 2006. *Eur J Agron* 26(3):215–223
- Van der Meer PJ, Jorritsma ITM, Kramer K (2002) Assessing climate change effects on long-term forest development: adjusting growth, phenology, and seed production in a gap model. *Forest Ecol Manag* 162(1):39–52
- Yadav B, Gynendra S, Verma AK, Dutta N, Sejian V (2013) Impact of heat stress on rumen functions. *Vet World* 6:992–996
- Zewdie Y (2003) Forest access: policy and reality in Kafa, Ethiopia. *Leisa-leusden* 19:21–22
- Ziervogel G, Ericksen, PJ (2010) Adapting to climate change to sustain food security. *Wiley Interdiscipl Rev: Climate Change* 1(4):525–540
- Ziervogel G, Frayne B (2011) Climate change and food security in Southern African cities. Urban food security series. Queen’s University and AFSUN, Kingston/Cape Town
- Ziska L, Crimmins A, Auclair A, DeGrasse S, Garofalo JF, Khan AS, Loladze I, Pérez de León AA, Showler A, Thurston J, Walls I (2016) Food safety, nutrition, and distribution. In: The impacts of climate change on human health in the United States: a scientific assessment. U.S. Global Change Research Program, Washington, DC

**Open Access** This chapter is licensed under the terms of the Creative Commons Attribution 4.0 International License (<http://creativecommons.org/licenses/by/4.0/>), which permits use, sharing, adaptation, distribution and reproduction in any medium or format, as long as you give appropriate credit to the original author(s) and the source, provide a link to the Creative Commons license and indicate if changes were made.

The images or other third party material in this chapter are included in the chapter’s Creative Commons license, unless indicated otherwise in a credit line to the material. If material is not included in the chapter’s Creative Commons license and your intended use is not permitted by statutory regulation or exceeds the permitted use, you will need to obtain permission directly from the copyright holder.





# *Brachiaria* Grass for Climate Resilient and Sustainable Livestock Production in Kenya

# 40

D. M. G. Njarui, M. Gatheru, and S. R. Ghimire

## Contents

Introduction .....	756
Methodology .....	758
Description of the Study Area .....	758
<i>Brachiaria</i> Grass Validation Trial .....	759
Treatments, Field Design, and Management .....	760
Data Collection and Statistical Analysis .....	760
Weather and Agronomy Data .....	760
Forage Quality Analysis .....	761
Soil Mineral Analysis .....	761
Participatory Evaluation of <i>Brachiaria</i> Grass Cultivars .....	761
On-Farm Evaluation of <i>Brachiaria</i> Grass Cultivars .....	762
Strategies Used to Upscale <i>Brachiaria</i> Grass Cultivars .....	762
Statistical Data Analysis .....	763
Results and Discussion .....	763
<i>Brachiaria</i> Grass Validation Trial .....	763
<i>Brachiaria</i> Grass On-Farm Trials .....	767

This chapter was previously published non-open access with exclusive rights reserved by the Publisher. It has been changed retrospectively to open access under a CC BY 4.0 license and the copyright holder is “The Author(s)”. For further details, please see the license information at the end of the chapter.

D. M. G. Njarui (✉) · M. Gatheru  
Kenya Agricultural and Livestock Research Organization (KALRO), Katumani, Kenya  
e-mail: [donaldnjarui@yahoo.com](mailto:donaldnjarui@yahoo.com)

S. R. Ghimire  
The Biosciences eastern and central Africa – International Livestock Research Institute  
(Beca-ILRI) Hub, Nairobi, Kenya

Participatory Selection of <i>Brachiaria</i> Grass Cultivars .....	768
Upscaling <i>Brachiaria</i> Grasses Cultivars .....	772
Conclusions and Way Forward .....	773
References .....	774

## Abstract

*Brachiaria* grass is a “climate smart” forage that produces high amount of palatable and nutritious biomass for livestock and performs well in infertile soils, sequesters carbon in soil, and provides several environmental benefits. The objective of the study was to validate the productivity of *Brachiaria* grass and upscale the suitable cultivars for improved livestock feed resources in Kenya. We assume integrating *Brachiaria* grass into mixed crop-livestock system will enhance feed availability and livestock productivity, leading to increased food and nutrition security. Farmer participatory approach was adopted to evaluate and promote four *Brachiaria* grass (*Brachiaria decumbens* cv. Basilisk, *B. brizantha* cvs. Xaraes, Piata, and MG-4) in the Central Highland and Eastern Midland of Kenya. The extension/advisory approaches used to promote *Brachiaria* grass cultivars included field days, village knowledge centres, agricultural shows, posters, and linkages with other institutions through multi-actor platform established under the InnovAfrica project. Generally, *Brachiaria* grass cultivars were more productive than the control (Rhodes grass) in most harvests reaching peak of 5.1–7.7 t/ha in the fifth harvest. For Rhodes grass, DM was less than 4 t/ha in all harvest and died by sixth harvest. Similarly, based on farmers’ evaluation using phenotypic traits, the *Brachiaria* grass cultivars had higher score than Rhodes grass except cv. Piata. The mean score ranged from 2.75 to 3.19 for *Brachiaria* cultivars, while for Rhodes the mean score was 2.63. Within 2 years of intervention, over 4000 farmers in the 2 project sites and additional 1500 farmers from other parts of the country have planted the *Brachiaria* grass. The demand for *Brachiaria* grass seeds is increasing due to benefits gained, e.g., increased milk production from dairy cattle fed on the grass. Our study will quantify the associated benefits from cultivation of *Brachiaria* grass with respect to a set of ecological, food and nutrition security, and social-economic indicators.

## Introduction

There is wide empirical evidence that livestock plays an important economic role in Kenya. The livestock subsector contributes about 12% to the national Gross Domestic Product in the country (RoK 2019). Livestock serves multiple purposes that include food and nutritional security. Livestock is sold to generate income; provide manure and draft power for crop production, skins, and transport; and serve in social-cultural function and source of prestige within the pastoral society. The effects of climate change have challenged the sustainability of livestock

sector. The changing pattern and frequency of extreme climatic conditions such as droughts and floods have great impacts on livestock and the associated livelihoods (Freier et al. 2012; Schilling et al. 2012). Extreme climatic events such as droughts and heavy rains are expected to become more frequent in the Horn of Africa and part of East Africa (Christensen et al. 2007; World Bank 2013). Climate change leads to reductions in livestock productivity by indirectly compromising the availability of forages (Martin et al. 2016). The impacts on forage availability and quality may include changes in herbage growth, changes in composition of vegetation, and overall changes in herbage quality (Thornton et al. 2009).

In the mixed crop-livestock production systems where dairy farming is practiced, several forage innovations have been in use to alleviate livestock feed shortage. Napier grass is the most widely cultivated forage in the humid and subhumid regions of Kenya, and over 90% of dairy farmers depend on it, but it is threatened by smut and stunting diseases. These diseases have been reported to cause damage ranging from 5% to 90% (Lusweti et al. 2004). There is need to introduce climate smart technologies to improve resilience and sustainable livestock systems to climate change. One option is the *Brachiaria* grass which is a “climate smart” and increases livestock productivity (Muinga et al. 2016; Ngila et al. 2016).

*Brachiaria* is one of the important tropical forage grasses of African origin. It is widely cultivated in South America, Australia, and East Asia and has demonstrated success in transformation of beef and dairy industries (Ghimire et al. 2015). The perennial *Brachiaria* grass species produce high tonnage of foliage biomass, possess large root systems, sequester carbon into soils, is adapted to drought and low fertility soils, and provide several environmental benefits and ecosystem services (Djikeng et al. 2014; Njarui et al. 2016).

Although native to Eastern and Central Africa, its use as livestock feed has been extremely limited in the region including Kenya. Improved *Brachiaria* grass cultivars identified in evaluations conducted in Eastern Midlands (EM) region of Kenya can bridge the gap on livestock feed scarcity. However, there is limited information available on the productivity of different *Brachiaria* cultivars in different agroecological zones (AEZ) of Kenya. For instance, only a limited number of farmers are aware on benefits of *Brachiaria* grass to livestock productivity. The dry matter (DM) yield of *Brachiaria* grass varies in different AEZ and is influenced by a range of factors including cultivars, moisture, soil fertility, pest and disease, and management options. To achieve a sustainable impact of *Brachiaria* grass in Kenyan livestock sector, a wide-scale adoption of this grass is necessary. This requires selection of right cultivars for a given production environment prior to integration in the farming system, and engaging farmers in the cultivar selection would be crucial for adoption and scaling of the technology. The objective of the study was to validate the productivity of *Brachiaria* grass and upscale the suitable cultivars for improved livestock feed resources in Kenya.

## Methodology

### Description of the Study Area

The study was carried out in Kirinyaga County in Central Highlands (CH) and Kangundo subcounty in EM (Fig. 1). These sites differ in agroecological characteristics and diversity in farming system. *Brachiaria* grass had been tested and found to be suitable in the EM and hence was upscaled among the smallholder crop-livestock farmers who keep dairy cattle for commercial production. We adopted farmer participatory approach to evaluate and promote *Brachiaria* technologies in the CH and EM of Kenya using a novel extension approach – i.e., the Village Knowledge Centre (VKC) supported by innovative institutional approach – multi-actor platforms (MAP) that was established and being operational under the InnovAfrica project ([www.innovafrika.eu](http://www.innovafrika.eu)). On the other hand, *Brachiaria* grasses were evaluated in the CH since no research had been conducted on this grass in the region. The biophysical, farming system and other features of study sites are described below.

*Kirinyaga County:* Kirinyaga is one of the counties in the CH of Kenya. It is located between latitudes 0° 1' and 0° 40' South and longitudes 37° and 38° East and

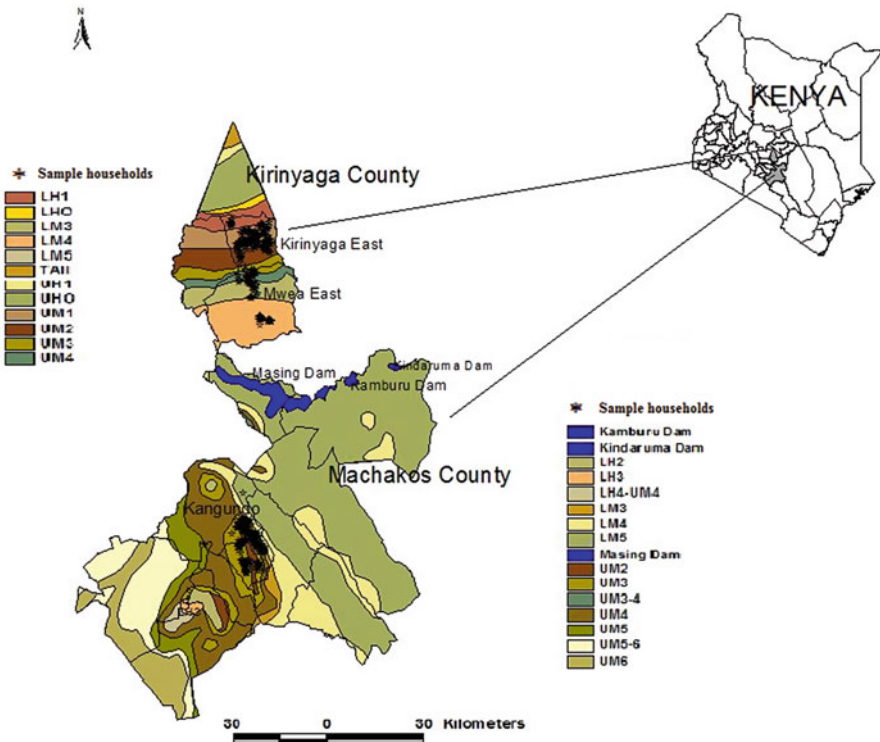


Fig. 1 Map showing project study sites



covers an area of 1478 km<sup>2</sup>. The altitude ranges from 1200 to 1700 m above sea level (asl), but in the northern side, it rises to 5200 m at the top of Mt. Kenya. The major soil is Humic Nitosols (Jaetzold et al. 2006). According to 2009 census, the population stood at 528,054 persons comprising 154,220 households (KNBS 2010).

Rainfall is bimodal, the long rains occurring from March and May and the short rains from October to December with average annual rainfall from 1200 to 1500 mm, which is well distributed and reliable for forage production. Temperature ranges from 12 °C to 27 °C (Jaetzold et al. 2006). Farming is predominantly mixed crop-livestock system. The main cash crop are rice, tea, and coffee, while maize, beans, bananas, and sweet potatoes are the main food crops but are often sold to generate income. Major livestock are cattle, goats, sheep, and poultry. Dairy farming is an important enterprise and is based on exotic cattle and their crosses, mainly under stall feeding system. Napier grass is the main feed resource, while banana stems, sweet potatoes, and crop residues are fed during the dry season.

The *Brachiaria* grass validation trial was conducted at Kamweti Agricultural Training Centre (ATC) in Kirinyaga County. Kamweti ATC lies on the southern slopes of Mt. Kenya at an altitude of 1755 m asl. The soil characteristics from samples taken (0–30 cm depth) indicated that the texture of the soil was sandy clay, with average pH of 4.87, total nitrogen content (0.23%) and organic carbon about 2.5%.

*Kangundo subcounty*: Kangundo, a subcounties of Machakos County, lies between latitudes 0° 45' and 1° 31' South and longitudes 36° 45' and 37° 45' East With altitude range of 800–1600 m asl. This subcounty has an area of 177 km<sup>2</sup> with population of about 94,367 (KNBS 2010). The predominant soils are Luvisols, Acrisols, and Ferralsols derived from the Precambrian “basement-complex” rocks (Simpson et al. 1996). They are often shallow, contain low organic matter and high sand content (Kusewa and Guiragossion 1989), but are well drained.

Rainfall pattern is similar to Kirinyaga County but is lower and ranges from 800 to 1050 mm annually. Inter-seasonal rainfall variation is large with coefficient of variation of between 45% and 58% (Keating et al. 1992). Temperatures vary from 14 °C to 29 °C with February and September being the hottest months and July and August the coolest months.

Maize is the most important cereal and is commonly intercropped with beans, cowpea, and pigeon pea. Coffee is an important cash crop in the Upper Midlands AEZ. The dairy cattle are mainly kept under stall feeding where feed is delivered. Improved forages such as Napier and Rhodes grass are planted but occupy only in a small proportion on the farm. Seasonal shortfall of feed resources is common due to prolonged drought and erratic rainfall and poor management of pastures.

## ***Brachiaria* Grass Validation Trial**

The *Brachiaria* grass cultivars tested in this study were identified from an evaluation conducted on several accessions and cultivars in Kenya (Njarui et al. 2016). They were found to be productive and had positive responses to livestock productivity. The objective of the validation trial was to evaluate the growth and productivity of

best bet *Brachiaria* grass cultivars. The validation trials were managed by researchers and were conducted at Kamweti ATC involving farmers.

---

## Treatments, Field Design, and Management

Four best bet *Brachiaria* grass cultivars, namely, *Brachiaria decumbens* cv. Basilisk, *B. brizantha* cvs. MG-4, Piata, and Xaraes, were compared with Rhodes grass – a commonly cultivated grass in the region. The treatments were arranged in a randomized block design with three replications in plot sizes of 4 m × 5 m with 1 m alley between plots. Ten rows were planted in each plot at interrows spacing of 50 cm. The land was ploughed and harrowed to a fine tilth before planting the seeds. The seeds were drilled by hand along shallow furrows of about 0.5–1 cm deep at a rate of 5 kg/ha for all the grasses and covered lightly with soil. Triple Super Phosphate fertilizer (TSP 46% P<sub>2</sub>O<sub>5</sub>) was applied in the planting furrows prior to sowing the seeds at a rate of 40 kg/ha P.

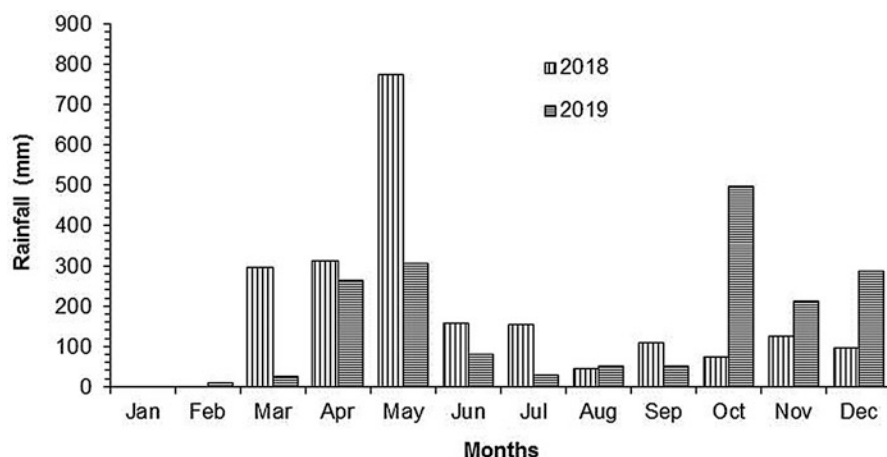
The trial was established in March 2018, during the long rains (LR) season (March–May). A standardization cut was made after the end of first wet season in June 2018 in all plots to stimulate uniform plant growth. Calcium ammonium nitrate (CAN, 26% N) was applied at a rate of 50 kg N/ha/season and commenced after the standardization cut. The fertilizer was broadcasted in the plots and covered slightly using hand hoes, approximately 1 week after onset of rainy season. The plots were kept weed-free by weeding using handheld hoes until the grass were fully established.

---

## Data Collection and Statistical Analysis

### Weather and Agronomy Data

Rainfall data was recorded from the weather station near the experimental plots. The first wet seasons (LR 2018) was regarded as the establishment phase and subsequent seasons as production phase. During the production phase, the data collected included plant numbers, tiller numbers, plant height, pests and diseases damage, and dry matter (DM) yield at 8 weeks interval. Numbers of plants were determined by counting plants within a 1 m<sup>2</sup> frame, randomly placed over two central rows. Tiller numbers and plant height were recorded for four plants in the same quadrat. Plant height was measured for from ground to the tip of plant. Pests and diseases damage were rated on a 1–5 scale; where 0 = no damage and 5 = highest damage. For dry matter (DM) yield determination, an area of 2 m × 2 m fixed quadrat was sampled by cutting the plants to around 5 cm stubble height using handheld sickles. The fresh materials were weighed, a subsample taken where necessary, and dried at 105 °C for 48 h. The rainfall at Kamweti ATC from January 2018 to December 2019 is given in Fig. 2. The total monthly rainfall in March and April 2018 was greater than 2019 rainfall recorded during the same months, whereas October and December rainfall was higher in 2019 than in 2018.



**Fig. 2** Monthly rainfall during the experimental period, March 2018–December 2019 at Kamweti ATC, Kenya

### Forage Quality Analysis

The herbage was analyzed for phosphorus, calcium, crude protein (CP), fibers, lignin, and ash for samples harvested in July 2019. The samples were dried at 65 °C in an oven to a constant weight and then ground with a hammer mill fitted with a 1 mm sieve, and about 200 g was preserved for analysis. Ash was determined by heating the samples at 550 °C for 8 h in a muffle furnace. Crude protein was determined using Micro-Kjeldahl according to the method of Association of Official Analytical Chemists (AOAC) (1990). The neutral detergent fiber (NDF), acid detergent fiber (ADF), and acid detergent lignin (ADL) were determined using the Ankom method of Van Soest et al. (1991).

### Soil Mineral Analysis

The soil samples were taken from a depth of 0 to 30 cm in each grass plot and air-dried. Analysis was carried out for organic carbon (OC), total N, K available P, and pH. Soil pH was measured in water (soil/water ratio of 1:2.5). The N was determined following the Micro-Kjeldahl method after Bremner and Keeney (1965), while P was measured by ascorbic acid method (Watanabe and Olsen 1965). The total OC and K were measured according to methods described by Okalebo et al. (2002).

### Participatory Evaluation of *Brachiaria* Grass Cultivars

The criterion for evaluation of the *Brachiaria* grasses was developed through a focus group discussion of 26 farmers randomly selected from the region. Scientists and

extension officers guided the farmers. A pairwise ranking matrix was used to rank the listed plant attributes in their order of importance which were then applied in the *Brachiaria* evaluation process. At the end of wet season, 72 farmers (26 females, 46 males) participated in the evaluation of the *Brachiaria* grass cultivars and Rhodes grass in the validation trial established at Kamweti ATC. The field assessment was based on grass phenotypic traits (visual herbage production, tillering capacity, height, hairiness, and easy to cut). For each trait, farmers recorded their individual scores for each individual grass cultivars in an evaluation form using a Likert scale of 1–4, where, 1 = poor, 2 = average, 3 = good and 4 = very good.

### **On-Farm Evaluation of *Brachiaria* Grass Cultivars**

Farmers who had previously participated in the project household baseline survey in Kangundo subcounty and Kirinyaga County were selected for *Brachiaria* grass on-farm trials. The criteria for selection of farmers were based on ownership of dairy cattle, willingness to participate in data collection, and ability of farmers to establish at least 0.1 ha of *Brachiaria* grass. The farmers were trained on establishment, management, and harvesting of the grasses. Individual farmers were provided with seeds of two cultivars (either Piata, Xaraes, or Basilisk). A total of 84 and 74 farmers received *Brachiaria* seeds in Kangundo subcounty and Kirinyaga County, respectively. Only 16 farmers were monitored in each site, and a farmer was considered as a replication. The land was prepared using local practices and sown in March and April 2018. Close supervision and monitoring was undertaken through joint action with farmers, extension, and researchers. A range of data was collected for assessment of ecological, food and nutrition security, and social-economic impact. For the ecological impact, the data collected includes *Brachiaria* biomass yield, soil organic carbon, effect of *Brachiaria* on milk production, and acreage under *Brachiaria*, while for the food and nutrition security impact, the data include availability of milk, level of consumption of milk, and dietary diversity. For the social-economic impact, the data collected include people aware of the technology, people growing *Brachiaria*, income from *Brachiaria*, and milk sales.

### **Strategies Used to Upscale *Brachiaria* Grass Cultivars**

Different extension and advisory services (EAS) have been used to upscale the suitable *Brachiaria* grass cultivars in Kangundo and Kirinyaga counties and other areas in Kenya. Some of the EASs include VKC, field days, agricultural shows, posters, and linkages with other institutions with support of multi-actor platform. VKC is a digital-based system linking farming communities with shared interests through smart phones and social media platforms such as WhatsApp. The VKC has been adopted to disseminate technology. The process involved sensitizing farmers on benefits of the grass, providing information on planting, management, and

harvesting followed by seed distribution. Each farmer was provided with seeds of two *Brachiaria* cultivars (40 g of each cultivar) enough to cover an area of 160 m<sup>2</sup>.

## Statistical Data Analysis

From the validation trial only data on plant tillers, height and dry matter yield were analyzed at each harvest. Likewise the values for forage quality were also statistically evaluated. The participatory evaluation scores from each farmer were entered in Microsoft Excel spreadsheet and a mean score for each criterion calculated for each grass cultivar by gender. The data were subjected to Analysis of Variance (ANOVA) using the statistical software GenStat 15 for windows (VSN International Ltd 2013). And where significant differences occurred, the means were separated using the Fisher's protected least significant difference (LSD) test at  $p < 0.05$ .

## Results and Discussion

### *Brachiaria* Grass Validation Trial

#### (i) Plant Height

Table 1 shows the mean plant height of four *Brachiaria* grass cultivars and Rhodes grass. Plant height at each harvest period varied among the grass cultivars and showed significant differences ( $p < 0.05$ ). Rhodes grass was taller than all the *Brachiaria* cultivars in the first three harvests and in the

**Table 1** Mean plant height (cm) of four *Brachiaria* grass cultivars and Rhodes grass (at 8 weeks cutting interval) at Kamweti ATC, Kenya

	2018		2019			
	Harvest 1	Harvest 2	Harvest 3	Harvest 4	Harvest 5	Harvest 6
Grass cultivars	29 Sept	20 Nov	15 Jan	12 Mar	4 July	22 Aug
<i>Brachiaria decumbens</i> cv. Basilisk	21.8 <sup>B</sup>	31.5 <sup>B</sup>	18.4 <sup>B</sup>	5.7 <sup>A</sup>	63.9 <sup>B</sup>	9.2 <sup>A</sup>
<i>Brachiaria brizantha</i> cv. MG-4	18.5 <sup>B</sup>	37.3 <sup>B</sup>	18.5 <sup>B</sup>	7.2 <sup>A</sup>	75.4 <sup>B</sup>	8.9 <sup>A,B</sup>
<i>Brachiaria brizantha</i> cv. Piata	13.5 <sup>B</sup>	43.0 <sup>B</sup>	11.0 <sup>B</sup>	7.0 <sup>A</sup>	27.9 <sup>C</sup>	6.4 <sup>C</sup>
<i>Brachiaria brizantha</i> cv. Xaraes	12.5 <sup>B</sup>	35.5 <sup>B</sup>	11.0 <sup>B</sup>	5.2 <sup>A</sup>	24.6 <sup>C</sup>	7.2 <sup>B,C</sup>
Rhodes grass cv. KAT R3 (control)	48.6 <sup>A</sup>	86.7 <sup>A</sup>	55.0 <sup>A</sup>	7.6 <sup>A</sup>	103.6 <sup>A</sup>	– <sup>a</sup>
LSD ( $p < 0.05$ )	13.1	12.3	14.2	N.S. <sup>b</sup>	17.3	1.9

Means with different superscript in the same column differ significantly at  $P < 0.05$

<sup>a</sup>Rhodes grass dried therefore no plants were measured

<sup>b</sup>N.S. not significant

fifth harvest, but in the fourth harvest, there was no significant difference among grass cultivars tested (Table 1). Lack of significance difference among the grasses in the fourth harvest was mainly due to poor rainfall experienced during the growing period, which reduced the growth of all grasses. Similarly, the low plant height in sixth harvest was attributed to low rainfall and low temperatures in 2019 (see Fig. 2)

(ii) *Tiller Numbers*

All the *Brachiaria* cultivars had higher tiller numbers than Rhodes grass at all harvests (Table 2). Xaraes recorded the highest number of tillers in most of the harvests. Tiller numbers increased from less than 100 tillers/plant at first harvest to greater than 120 tillers/plant in the fourth harvest for all the *Brachiaria* cultivars and Rhodes and declined in subsequent harvest except for Basilisk which increased slightly in fifth harvest. *Brachiaria* forms a massive root development, and hence nutrient uptake is likely to be high allowing the plant to continue increase in tillers. Reduce tillers number in fifth and sixth harvest were attributed to low rainfall and temperatures (see Fig. 2). The higher tillering ability of *Brachiaria* grass than Rhodes grass is due to difference in growth habit where *Brachiaria* forms rhizomes, while Rhodes grass spreads by stolon. Moreover, number of tillers is an indicator of resource use efficiency and increases the chances of survival and influences herbage yield (Laidlaw 2005) if water and nutrients are not limiting.

(iii) *Dry Matter Yield*

Six harvests for the DM yield were conducted during the production phase (Fig. 3a–f). There were no significant differences ( $p > 0.05$ ) on DM yield among the *Brachiaria* cultivars and Rhodes grass in the first three harvests and

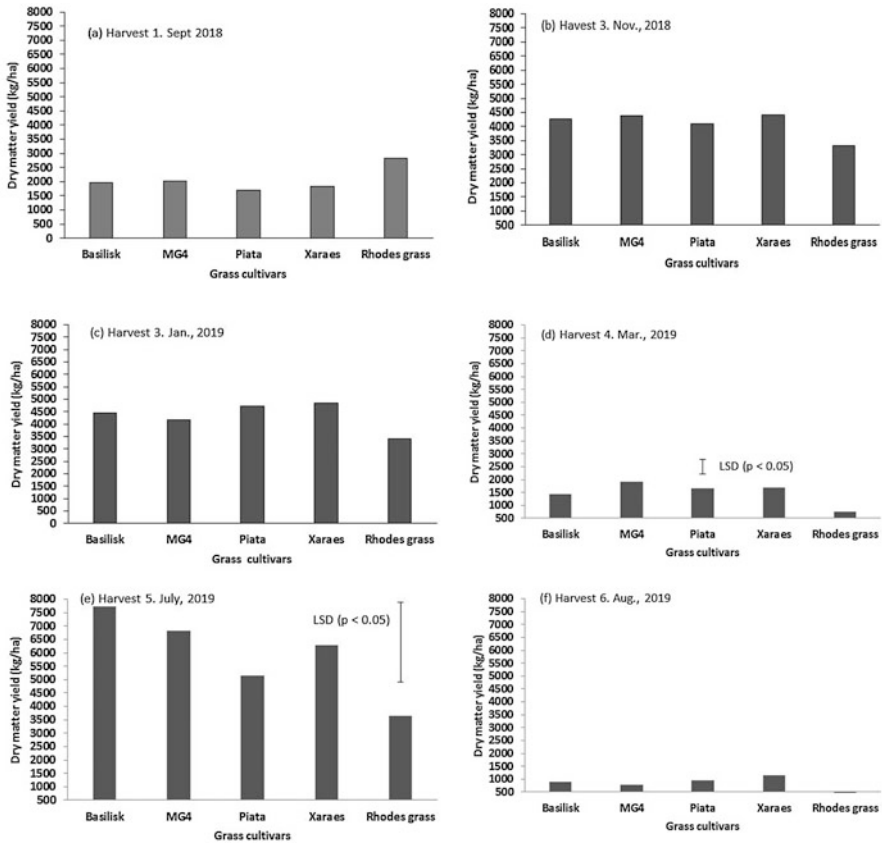
**Table 2** Mean number of tillers/plant of four *Brachiaria* grass cultivars and Rhodes grass (at 8 weeks cutting interval) at Kamweti ATC, Kenya

	2018		2019			
	Harvest 1	Harvest 2	Harvest 3	Harvest 4	Harvest 5	Harvest 6
Grass cultivars	29 Sept	20 Nov	15 Jan	12 Mar	4 July	22 Aug
<i>Brachiaria decumbens</i> cv. Basilisk	83.3 <sup>A,B</sup>	116.3 <sup>A</sup>	127.7 <sup>A</sup>	140.3 <sup>B</sup>	163.3 <sup>A</sup>	137.3 <sup>A</sup>
<i>Brachiaria brizantha</i> cv. MG-4	89.3 <sup>A,B</sup>	95.3 <sup>A</sup>	121.3 <sup>A</sup>	126.0 <sup>B</sup>	110.5 <sup>B</sup>	102.4 <sup>A</sup>
<i>Brachiaria brizantha</i> cv. Piata	72.7 <sup>B,C</sup>	78.7 <sup>A</sup>	142.7 <sup>A</sup>	151.7 <sup>B</sup>	131.1 <sup>A,B</sup>	120.8 <sup>A</sup>
<i>Brachiaria brizantha</i> cv. Xaraes	103.0 <sup>A</sup>	108.7 <sup>A</sup>	156.3 <sup>A</sup>	183.3 <sup>A</sup>	167.5 <sup>A</sup>	184.5 <sup>A</sup>
Rhodes grass cv. KAT R3 (control)	46.7 <sup>C</sup>	34.7 <sup>B</sup>	45.7 <sup>B</sup>	48.7 <sup>C</sup>	31.4 <sup>C</sup>	– <sup>a</sup>
LSD ( $p < 0.05$ )	30.3	43.5	55.3	29.9	46.5	N.S. <sup>b</sup>

Means with different superscript in the same column differ significantly at  $P < 0.05$

<sup>a</sup>Rhodes grass dried therefore no plants were measured

<sup>b</sup>N.S. not significant



**Fig. 3** Dry matter yield of four *Brachiaria* grass cultivars and Rhodes grass harvested every 8 weeks at Kamweti ATC, Kenya

sixth harvest. Significant ( $p < 0.05$ ) difference in yield was recorded in the fourth (Fig. 3d) and fifth harvests (Fig. 3e). In the fourth harvest, all *Brachiaria* cultivars outyielded Rhodes grass, but yields were not significantly different among themselves (Fig. 3). Similar studies by Nyambati et al. (2016) in an area that has unimodal rainfall pattern showed no significance difference among the same *Brachiaria* cultivars, but their yields were higher than those of Rhodes grass. However, in the fifth harvest, only Basilisk had higher ( $P < 0.05$ ) DM yield (7.7 t/ha) than Rhodes grass (3.6 t/ha) but did not differ significantly with the other *Brachiaria* grass cultivars. Generally, *Brachiaria* yields were relatively higher in the second (4.1–4.4 t/ha), third (4.1–4.8 t/ha), and reached peak in the fifth (5.1–7.7 t/ha) harvests, and this was attributed to moisture availability. The first harvest (Fig. 3a) was conducted during the long dry season, while the fourth (Fig. 3d) was carried out toward the end of the short dry season. The second and third harvest was conducted during the wet season. The DM yields were appreciably higher than yield recorded by Njarui et al. (2016) in EM.

**Table 3** Chemical composition (% of DM) of *Brachiaria* grass cultivars and Rhodes grass harvested at Kamwetii ATC, Kenya

Grass cultivars	Calcium	Phosphorus	CP	ADF	NDF	ADL	Ash
<i>Brachiaria decumbens</i> cv. Basilisk	0.15 <sup>A</sup>	0.37 <sup>A</sup>	11.60 <sup>A</sup>	41.49 <sup>B</sup>	67.21 <sup>B,C</sup>	6.94 <sup>B</sup>	9.81 <sup>B</sup>
<i>Brachiaria brizantha</i> cv. MG-4	0.16 <sup>A</sup>	0.24 <sup>A</sup>	11.60 <sup>A</sup>	40.40 <sup>B</sup>	67.37 <sup>B,C</sup>	7.05 <sup>A,B</sup>	9.62 <sup>B</sup>
<i>Brachiaria brizantha</i> cv. Piata	0.13 <sup>A</sup>	0.53 <sup>A</sup>	11.73 <sup>A</sup>	36.82 <sup>C</sup>	65.02 <sup>C,D</sup>	6.00 <sup>B</sup>	9.54 <sup>B</sup>
<i>Brachiaria brizantha</i> cv. Xaraes	0.12 <sup>A</sup>	0.38 <sup>A</sup>	12.16 <sup>A</sup>	38.16 <sup>C</sup>	64.58 <sup>D</sup>	5.90 <sup>B</sup>	11.0 <sup>A</sup>
Rhodes grass cv. KAT R3 (control)	0.18 <sup>A</sup>	0.34 <sup>A</sup>	10.19 <sup>A</sup>	44.86 <sup>A</sup>	71.40 <sup>A</sup>	8.61 <sup>A</sup>	7.87 <sup>C</sup>
LSD (P < 0.05)	N.S. <sup>a</sup>	N.S.	N.S.	1.94	2.60	1.39	0.93
CV (%)	6.5	4.9	2.1	2.6	2.1	10.7	5.2

CP crude protein, ADF acid detergent fiber, NDF neutral detergent fiber, ADL acid detergent lignin  
Means with different superscript in the same column differ significantly at P < 0.05

<sup>a</sup>N.S. not significant

#### (iv) Forage Quality Composition

The result of forage quality analysis is presented in Table 3. The calcium, phosphorus, and CP content were not significantly different among the tested grasses. Significant differences were recorded in ADF, NDF, ADL, and ash content. Rhodes grass had higher ADF and NDF than *Brachiaria* grass cultivars, while the ADL content did not differ from that of MG-4. Xaraes had the highest ash content (11%), and the Rhodes grass had the lowest. However, all *Brachiaria* cultivars contained more CP than those reported from the Eastern Midland (7–10%) by Njarui et al. (2016) but were lower than that reported from a similar region – CH (12–15%) by Nyambati et al. (2016). The lower CP content from this study was attributed to difference in the sampling time as the grasses were harvested during the dry season and growth was poor. Nevertheless, CP ≥ 11% during the dry season is an indication that *Brachiaria* can provide good quality feed in CH. All the *Brachiaria* met the minimum level of CP required for ruminant maintenance (7%) and milk production (11%). Moreover, the NDF was below 72%, above which generally decreases DM intake. All the *Brachiaria* cultivars had lower ash content (12–15%) than those reported by Njarui et al. (2016).

#### (v) Soil Nutrients

There was no statistical significance difference (p > 0.05) on soil properties (pH, N, org C, P, and K) among the tested *Brachiaria* grass cultivars and the Rhodes grass (Table 4). However, the total N (0.20–0.21%) and organic carbon contents (2.2–2.3%) in all *Brachiaria* cultivars were higher than the Rhodes



**Table 4** Effects of *Brachiaria* grass cultivars and Rhodes grass on soil pH, organic carbon, and nutrients (nitrogen, phosphorus, and potassium), 18 months after planting

Grass cultivars	Soil pH (1:2.5 soil:H <sub>2</sub> O)	Nitrogen (%)	Org. carbon (%)	Phosphorus (ppm)	Potassium (me %)
<i>Brachiaria decumbens</i> cv. Basilisk	4.84	0.21	2.28	20.0	0.09
<i>Brachiaria brizantha</i> cv. MG-4	4.89	0.21	2.34	18.3	0.11
<i>Brachiaria brizantha</i> cv. Piata	4.74	0.20	2.29	15.0	0.09
<i>Brachiaria brizantha</i> cv. Xaraes	5.01	0.21	2.33	21.7	0.09
Rhodes grass cv. KAT R3 (control)	4.91	0.16	1.74	20.0	0.11
LSD (P < 0.05)	N.S. <sup>a</sup>	N.S.	N.S.	N.S.	N.S.
CV (%)	3.6	13.9	15.4	22.3	15.9

<sup>a</sup>N.S. not significant

grass. The org C contents in the *Brachiaria* fields will improve the organic matter content of the soils, which in turn will enhance soil fertility and increase productivity. This makes *Brachiaria* grass suitable for adaptation and mitigation measures to climate change effects in Kenya and possibly in other sub-Saharan African countries. However, the effect of *Brachiaria* on soil pH would require relatively a longer period.

### ***Brachiaria* Grass On-Farm Trials**

The mean DM yield of *Brachiaria* grass cultivar in Kirinyaga and Kangundo is given in Table 5. There were no statistical significant differences ( $p > 0.05$ ) on DM yield among the *Brachiaria* cultivars grass within and between sites. Of the 16 farms monitored in each site, there were large variations in yield for each *Brachiaria* cultivars tested.

The large difference in yield between farms for a given cultivar was attributed to farmers' failure to follow recommended agronomic practices such as proper plant spacing, lack of weeding at establishment, limited use of fertilizer, etc. Generally, where the yields were poor the grasses were established in eroded and less fertile part of farm and no fertilizer application. In contrast in farms where the yields were high, the land was well terraced, and farmer had adopted proper soil conservation practices. Additionally, farmers had applied either cattle manure or inorganic fertilizer or both. The higher yield achieved in Kirinyaga was attributed to more rainfall experienced from June to October unlike in Kangundo where there was no rains resulting in the cessation of plant growth.

**Table 5** Mean DM yield among the *Brachiaria* grass cultivars in Kirinyaga and Kangundo study sites

<i>Brachiaria</i> grass cultivars	Kirinyaga	Kangundo	LSD ( $p < 0.05$ )
	DM yield (kg/ha)		
<i>Brachiaria decumbens</i> cv. Basilisk	6702 (1704–18,156)	5485 (1081–12,204)	N.S.
<i>Brachiaria brizantha</i> cv. Piata	6884 (2548–15,363)	6447 (3510–10,922)	N.S.
<i>Brachiaria brizantha</i> cv. Xaraes	5108 (1733–12,962)	5680 (1175–12,856)	N.S.
LSD ( $p < 0.05$ )	N.S. <sup>a</sup>	N.S.	

Values in parenthesis are range of DM yield

<sup>a</sup>N.S. not significant

### Box 1

**Effects of *Brachiaria forage* on social-economic conditions:** By August 2019 approximately 1320 smallholder farmers (18.2% females) mainly involved in dairy cattle farming had been provided with *Brachiaria* grass seeds in Kirinyaga County. In Kangundo, 720 smallholder farmers (23% were females) received the seeds. Report from field indicates that each farmer has given out splits to at least two other farmers. Conservative estimate put the numbers of farmers to over 4000 farmers implying a high rate of uptake of the technology in the project areas. Seeds were also distributed to 1200 farmers in Nyeri County and over 300 farmers in other parts of Kenya. So far, the project has not found any farmer who has abandoned growing *Brachiaria*. Farmers are enthusiastic about the grass, and a good number have expanded the acreage under *Brachiaria* grass. Farmers have also reported increase in milk production from dairy cattle fed *Brachiaria* grasses. However, there were variation in terms increase, but the values were within the range of 15–40% recorded by Muinga et al. (2016). This implies *Brachiaria* has contributed to increased milk availability for consumption at household level and for sale to generate income. However, there are plan to carry out on-farm feeding trial jointly with farmers to ascertain the actual benefits of *Brachiaria* in term of milk production. In Kirinyaga, youths have formed groups with aim of baling *Brachiaria* hay for sale to generate income. (Source: Field Survey)

### Participatory Selection of *Brachiaria* Grass Cultivars

During the FGD, farmers identified 16 plant attributes that are important when selecting grasses (Table 6). Grasses that give high milk yield when fed to livestock were ranked first followed by highly nutritious grasses while color was the least important criteria. These findings were consistent with earlier work carried

**Table 6** Pairwise ranking matrix of farmers' criteria in selecting grasses for livestock production in Kirinyaga, Kenya

Plant attributes	FG	T	DT	HT	DR	PA	PR	HMY	HNV	LH	DGC	EC	PE	EE	EM	HBV	Total	Rank
Fast growth (FG)		T	DT	HT	DR	PA	PR	HMY	HNV	LH	FG	EC	PE	EE	EM	HBV	1	15
Tall (T)			DT	HT	DR	PA	PR	HMY	HNV	LH	DGC	EC	PE	EE	EM	HBV	1	14
Drought tolerant (DT)				HT	DR	PA	PR	HMY	HNV	LH	DT	EC	PE	EE	EM	HBV	3	13
High tillering (HT)					DR	PA	PR	HMY	HNV	LH	HT	EC	PE	EE	EM	HBV	4	12
Disease resistant (DR)						PA	DR	HMY	HNV	DR	DR	DR	DR	DR	DR	DR	12	3rd
Highly palatable (PA)							PA	HMY	HNV	LH	PA	EC	PE	EE	EM	HBV	7	9
Pest resistance (PR)								HMY	HNV	PR	PR	PR	PR	PR	PR	PR	11	5
Give high milk yield (HMY)									HMY	HMY	HMY	HMY	HMY	HMY	HMY	HMY	15	1st
High nutritive value (HNV)										HNV	HNV	HNV	HNV	HNV	HNV	HNV	14	2nd
Less hairy (LH)											LH	LH	PE	EE	EM	HBV	7	10
Dark green color (DGC)												EC	PE	EE	EM	HBV	0	16
Easy to cut (EC)													PE	EE	EM	HBV	6	11

(continued)

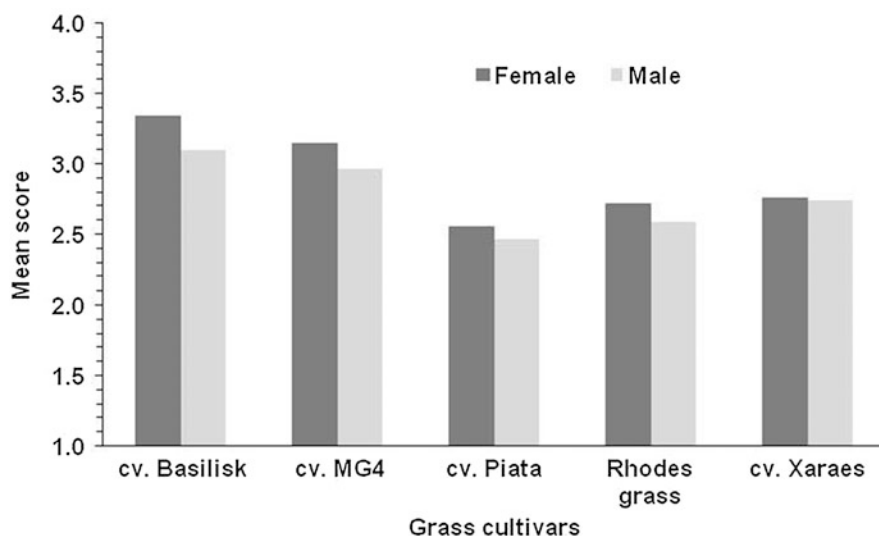


elsewhere in Kangundo by Gatheru et al. (2016). They reported that forages that gave high milk yield when fed to cattle and nutritionally balanced were priority traits in selecting feed for livestock. There were significant differences ( $p < 0.05$ ) in farmers' scores for herbage, tillers, and tallness between the cultivars (Table 7). Overall, Basilisk had the highest mean score for the five attributes followed by MG-4, while Piata had the lowest. There were no significant differences on farmers' scores for hairiness and ease of cutting between the cultivars. The ranking order for the cultivars was not different between females and male farmers (Fig. 4).

**Table 7** Farmers' mean scores for selected criteria from evaluation of *Brachiaria* cultivars

Grass cultivars	Selection criterion					Mean score	Rank
	Herbage production	Tillering capacity	Height at harvest	Hairiness	Easy to cut		
Basilisk	3.40	3.36	3.23	2.66	3.28	3.19	1
MG-4	3.19	3.19	2.70	2.99	3.09	3.03	2
Piata	2.32	2.49	2.00	2.67	3.01	2.50	5
Xaraes	2.63	2.79	2.21	2.99	3.12	2.75	3
Rhodes grass	2.16	1.85	3.13	2.97	3.03	2.63	4
LSD ( $p < 0.05$ )	0.31	0.29	0.29	N.S. <sup>a</sup>	N.S.		

<sup>a</sup>N.S. not significant

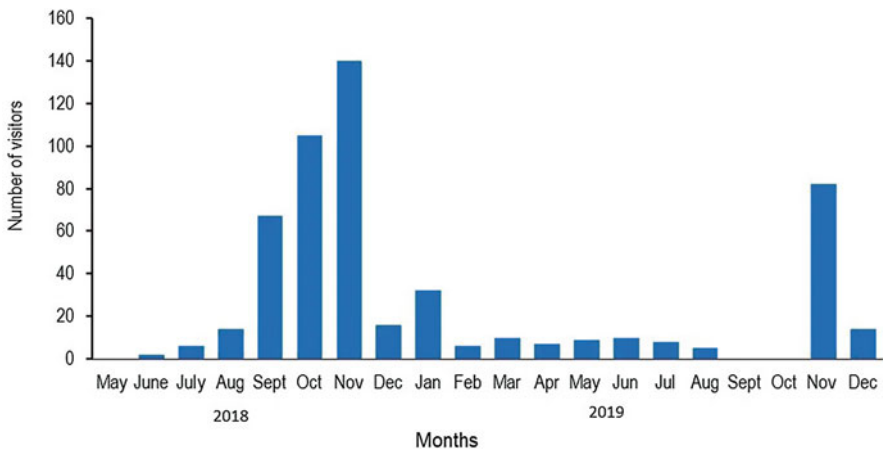


**Fig. 4** Evaluation score for *Brachiaria* grass cultivars and Rhodes grass categorized by gender

## Upscaling *Brachiaria* Grasses Cultivars

*Multi-actor Platform:* The multi-actor platform (MAP) members are composed from institution in private sectors, policy makers, dairy cooperative societies, extension services, farmers, and researchers. The MAP members were involved at InnovAfrica project inception phase during planning, site selection, and development of implementation framework. The MAPs have contributed in *Brachiaria* grass validation trial particularly in selection of farmers and development of selection criteria. They participate in field project evaluation and monitoring every 6 months and provide useful feedback to correct any divergence from the planned activities. They are also involved in upscaling of *Brachiaria* grass technologies through field days and distribution of seeds. For example, one MAP member who is committee of Mukurwe-ini Wakulima Dairy Cooperative Society has distributed seeds to over 1200 farmers who are members of the society in Nyeri County.

*Village knowledge Centre:* One VKC was established in Kangundo village of Kangundo subcounty in May 2018. From May 2018 to December 2019, a total of 530 people (comprising of farmers, extension agents the public sector, and non-governmental organization) and other stakeholders visited the VKC (Fig. 5) primarily to get information on *Brachiaria* grasses and on other issues (e.g., horticulture, poultry, bee, rabbits, microfinance). Most of the visitors to the VKC were over 50 years old. The VKC has connected over 300 farmers on social media (two WhatsApp Group). These have provided a platform where information on cultivation of *Brachiaria* grass including management, conservation, and feeding is shared. However, social networking is an important mean for promoting technology adoption (Brhane et al. 2019).



**Fig. 5** Number of visitors to the Village Knowledge Centre from May 2018 to December 2019 in Kangundo, Kenya

**Box 2 Other *Brachiaria* Upscaling Strategies Adopted**

*Field days:* In May 2018, a farmer field day was held in Kangundo village to provide first-hand information to farmers and relevant stakeholders on *Brachiaria*-livestock value chain and related technologies and its impact on the feed security and livestock productivity. A total of 93 people representing smallholder dairy farmers, members of a small-scale dairy processing group, County extension agents, local leaders, and InnovAfrica partners attended.

*Agricultural show and exhibition:* InnovAfrica project participated in Agricultural Show of Kenya (ASK), Machakos Branch, in June 2018 and 2019 to create awareness on the *Brachiaria* technologies. The grasses were planted in small plots within the ASK ground for exhibition to farmers. Posters with details on the establishment, management, and nutritive quality of the grasses were also displayed. In 2018 an estimated 770 show attendants (farmers, scholars, and students) visited the *Brachiaria* grass plots, and the number increased to 1050 in 2019.

*Posters:* The project has also adopted posters to create farmer awareness on the availability of *Brachiaria* grass seeds for planting. Over 550 and 770 posters written in vernacular were distributed in Kirinyaga County and Kangundo subcounty, respectively. The posters were displayed at strategic locations where they were easily visible. This included trees along rural roads, in market centers, petrol stations, churches, dairy cooperatives, premises, and other public buildings where the local people visit frequently.

*Agricultural Training Centre:* The project has partnered with Kamweti ATC and Wambugu ATC in Kirinyaga and Nyeri Counties, respectively, to accelerate the upscaling of *Brachiaria* grass technology. These Centers normally organize field days, train farmers, and conduct demonstrations on proven technologies on crops, forages, and livestock. The role of the ATCs is to bulk the *Brachiaria* grass and distribute splits to farmers.

---

## Conclusions and Way Forward

This study is a farmer led experimentation to test *Brachiaria* grass for livestock production in Kirinyaga County and upscaling it in Kangundo subcounty. The validation trial showed that all the *Brachiaria* grass cultivars were more productive than the control (Rhodes grass) in most of the harvests. Similarly, based on phenotypic traits used by farmers to evaluate the grass, all the *Brachiaria* grass cultivars had higher mean score than Rhodes grass. Thus, *Brachiaria* has a potential to improve the feed availability in the region tested and other areas of Kenya and enhance food and nutrition security. The org C contents in the *Brachiaria* fields will improve the organic matter content of the soils which in turn will enhance soil fertility and increase productivity. This makes *Brachiaria* grass suitable for use in

adaptation and mitigation measures to climate change effects in Kenya and possibly in other SSA countries. Over 4000 farmers are now engaged in cultivation *Brachiaria* grass in the study sites and additional 1500 farmers in other parts of Kenya, because of increased awareness by the InnovAfrica project using innovative EASs including VKC, ASK, posters, social media, and MAPs engagement. The demand for *Brachiaria* seeds is increasing due to benefits gained in terms of increased milk from livestock fed on the grass. Nevertheless, there is need to continue to upscale *Brachiaria* grass using already existing avenues and/or establish new ones.

**Acknowledgements** This is funded by the European's Union H2020, research and innovation program under Grant Agreement No. 727201.

---

## References

- Association of Official Analytical Chemists (AOAC) (1990) Official methods of analysis of the AOAC, 15th edn. AOAC, Arlington, pp 1–1298
- Bremner JM, Keeney DR (1965) Steam distillation methods for determination of ammonium, nitrate and nitrite. *Anal Chem Acta* 32:485–495
- Brhane G, Fantaye Belay F, Gebreselassie T, Desta D (2019) Enhancing sorghum yield through demonstration of improved sorghum varieties in Tanqua-Abergelle Wereda, Central Zone of Tigray, Ethiopia. *J Agric Ext Rural Dev* 11:11–16. <https://doi.org/10.5897/JAERD2018.1020>
- Christensen NJH, Hewitson B, Busuioc A, Chen A, Gao X, Held I, Jones R, Kolli RK, Kwon W-T, Laprise R, Magana Rueda V, Mearn SL, Menendez CG, Raisanen J, Rinke A, Sarr A, Whetton P (2007) Chapter 11: Regional climate projections. In: *Climate change 2007: the physical science basis. Contribution of working group I to the Fourth Assessment Report of the Intergovernmental Panel on Climate Change*. Cambridge University Press, Cambridge, pp 847–940
- Djikeng A, Rao IM, Njarui D, Mutimura M, Caradus J, Ghimire SR, Johnson L, Cardoso JA, Ahonsi M, Kelemu S (2014) Climate-smart *Brachiaria* grasses for improving livestock production in East Africa. *Trop Grassl-Forrajess Trop* 2(1):38–39
- Freier KP, Bruggemann R, Scheffran J, Finckh M, Schneider UA (2012) Assessing the predictability of future livelihood strategies of pastoralists in semi-arid Morocco under climate change. *Technol Forecast Soc Chang* 79(2):371–382
- Gatheru M, Njarui DMG, Gichangi EM (2016) Participatory evaluation and selection of suitable *Brachiaria* grass cultivars for production in the semi-arid eastern Kenya. In: Njarui DMG, Gichangi EM, Ghimire SR, Muinga RW (eds) *Climate smart Brachiaria grasses for improving livestock production in East Africa – Kenya experience*. Proceedings of the workshop held in Naivasha, Kenya, 14–15 Sept 2016. Nairobi, pp 124–131
- Ghimire S, Njarui D, Mutimura M, Cardoso J, Johnson L, Gichangi E, Teasdale S, Odokonyero K, Caradus J, Rao I, Djikeng A (2015) Climate-smart *Brachiaria* for improving livestock production in East Africa: emerging opportunities. In: Vijaya D, Srivastava M, Gupta C, Malaviya D, Roy M, Mahanta S, Singh J, Maity A, Ghos P (eds) *Sustainable use of grassland resources for forage production, biodiversity and environmental protection*. Proceedings of 23rd International Grassland Congress, 20–24 Nov 2015, New Delhi, pp 361–370
- Jaetzold R, Schmidt H, Hornetz B, Shisanya C (2006) *Farm management handbook of Kenya*, vol. II: natural conditions and farm management information. Part C: East Kenya Subpart C2 Coast Province, 2nd edn. Ministry of Agriculture and GIZ, Nairobi
- Keating BA, Siambi MN, Wafula BM (1992) The impact of climatic variability on cropping research in semi-arid Kenya between 1955 and 1985. In: Probert ME (ed) *A search for strategies*



- for sustainable dryland cropping in semi-arid Eastern Kenya. ACIAR proceedings no. 41, Canberra, pp 16–25
- Kenya National Bureau of Statistics (KNBS) (2010) The 2009 Kenya population and housing census: vol. II: population and household distribution by socio-economic characteristics. Kenya National Bureau of Statistics, Nairobi, p 438
- Kusewa P, Guiragossion V (1989) Research priorities for enhancing crop productivity in marginal areas of Kenya. In: Agricultural research in Kenya, achievements, challenges and prospects. Proceedings of the 1st KARI scientific conference held at Panafric Hotel Kenya, 14–16 Aug 1989, pp 21–36
- Laidlaw A (2005) The relationship between tiller appearance in spring and contribution of dry-matter yield in perennial ryegrass (*Lolium perenne* L.) cultivars differing in heading date. *Grass Forage Sci* 60:200–209
- Lusweti CM, Nandasaba J, Onginjo E, Asena D (2004) Preliminary results of disease survey on Napier grass in selected sites of Western Kenya. Pasture research annual report 2004. National Agricultural Research Centre, Kitale
- Martin R, Linstädter A, Frank K, Müller B (2016) Livelihood security in face of drought – assessing the vulnerability of pastoral households. *Environ Model Softw* 75:414–423
- Muinga RW, Njunie MN, Gatheru M, Njarui DMG (2016) The effects of *Brachiaria* grass cultivars on lactation performance of dairy cattle in Kenya. In: Njarui DMG, Gichangi EM, Ghimire SR, Muinga RW (eds) Climate smart *Brachiaria* grasses for improving livestock production in East Africa – Kenya experience. Proceedings of the workshop held in Naivasha, Kenya, 14–15 Sept 2016. Nairobi, pp 229–237
- Ngila P, Njarui DM, Musimba NK, Njunie MN (2016) Performance of Galla goats fed different cultivars of *Brachiaria* in the coastal lowlands of Kenya. *J Fish Livest Prod* 5:210. <https://doi.org/10.4172/2332-2608.1000210>
- Njarui DMG, Gichangi EM, Ghimire SR, Muinga RW (eds) (2016) Climate smart *Brachiaria* grass for improving livestock production in East Africa – Kenya experiences. Kenya Agricultural and Livestock Research Organization, Nairobi, p 271. <https://cgspace.cgiar.org/handle/10568/79797>
- Nyambati EM, Ayako W, Mailu S, Chelimo EJ, Njarui DMG (2016) Production and nutritive quality of *Brachiaria* grass cultivars subjected to different cutting intervals in the cool sub-humid highlands of central Kenya. In: Njarui DMG, Gichangi EM, Ghimire SR, Muinga RW (eds) Climate smart *Brachiaria* grasses for improving livestock production in East Africa – Kenya experience. Proceedings of the workshop held in Naivasha, Kenya, 14–15 Sept 2016. Nairobi, pp 62–69
- Okalebo JR, Gathua KW, Woomer PL (2002) Laboratory methods of soil and plant analysis: a working manual, 2nd edn. TSBF-CIAT and SACRED Africa, Nairobi, p 128
- RoK (Republic of Kenya) (2019) Ministry of Agriculture, Livestock, Fisheries and Irrigation, State Department for livestock. Draft National Livestock Policy, Kenya, p 75
- Schilling J, Freier KP, Hertig E, Scheffran J (2012) Climate change, vulnerability and adaptation in North Africa with focus on Morocco. *Agric Ecosyst Environ* 156:12–26
- Simpson JR, Okalebo JR, Lubulwa G (1996) The problem of maintaining soil fertility in Eastern Kenya. A review of relevant research. ACIAR monograph no. 41, Canberra, p 60
- Thornton PK, van de Steeg J, Notenbaert A, Herrero M (2009) The impacts of climate change on livestock and livestock systems in developing countries: a review of what we know and what we need to know. *Agric Syst* 101:113–127
- Van Soest PJ, Robertson JD, Lewis BA (1991) Methods for dietary fibre, neutral detergent fibre and non-starch polysaccharides in relation to animal nutrition. *J Dairy Sci* 74:3583–3597
- VSN International Ltd (2013) Genstat for windows, 15th edn. VSN International Ltd, Hemel Hempstead
- Watanabe FS, Olsen SR (1965) Test of an ascorbic acid method for determining phosphorus in water and sodium bicarbonate extracts from soils. *Soil Sci Soc Am J* 29:677–678
- World Bank (2013) Turn down the heat: climate extremes, regional impacts, and the case for resilience – a report for the World Bank by the Potsdam Institute for Climate Impact Research and Climate Analytics. World Bank, Washington, DC, p 254

**Open Access** This chapter is licensed under the terms of the Creative Commons Attribution 4.0 International License (<http://creativecommons.org/licenses/by/4.0/>), which permits use, sharing, adaptation, distribution and reproduction in any medium or format, as long as you give appropriate credit to the original author(s) and the source, provide a link to the Creative Commons license and indicate if changes were made.

The images or other third party material in this chapter are included in the chapter's Creative Commons license, unless indicated otherwise in a credit line to the material. If material is not included in the chapter's Creative Commons license and your intended use is not permitted by statutory regulation or exceeds the permitted use, you will need to obtain permission directly from the copyright holder.





# Climate Change Adaptation Through Sustainable Water Resources Management in Kenya: Challenges and Opportunities

# 41

Shilpa Muliyl Asokan, Joy Obando, Brian Felix Kwena, and Cush Ngonzo Luwesi

## Contents

Introduction .....	778
East African Community and Climate Change Impacts .....	779
Kenya: Country Climate and Water Profile, Climate Change Impacts .....	780
Wise Water Management Toward Climate Change Adaptation .....	781
Climate Resilience Through Water Management .....	782
Water: A Cross-Cutting Factor in Agenda 2030 SDGs .....	784
Conclusion .....	785
References .....	785

## Abstract

Water is the medium through which society experiences the most dramatic and direct manifestations of climate change. At the same time, water has a critical

This chapter was previously published non-open access with exclusive rights reserved by the Publisher. It has been changed retrospectively to open access under a CC BY 4.0 license and the copyright holder is “The Author(s)”. For further details, please see the license information at the end of the chapter.

S. M. Asokan (✉)

Climate Change and Sustainable Development, The Nordic Africa Institute, Uppsala, Sweden

e-mail: [shilpa.asokan@nai.uu.se](mailto:shilpa.asokan@nai.uu.se)

J. Obando

Department of Geography, Kenyatta University, Nairobi, Kenya

e-mail: [obandojoy@yahoo.com](mailto:obandojoy@yahoo.com); [obando.joy@ku.ac.ke](mailto:obando.joy@ku.ac.ke)

B. F. Kwena

Kenya Water for Health Organization, Nairobi, Kenya

e-mail: [felix.brian@kwaho.org](mailto:felix.brian@kwaho.org)

C. N. Luwesi

University of Kwango, Kenge, Democratic Republic of Congo

e-mail: [cushngonzo@gmail.com](mailto:cushngonzo@gmail.com)

© The Author(s) 2021

W. Leal Filho et al. (eds.), *African Handbook of Climate Change Adaptation*,  
[https://doi.org/10.1007/978-3-030-45106-6\\_148](https://doi.org/10.1007/978-3-030-45106-6_148)

777

role to play in climate change adaptation and is central towards achieving Africa Water Vision 2025, and the targets set for the 2030 Agenda for Sustainable Development as well as the Kenya Vision 2030. There are fundamental challenges that need to be addressed in order to achieve sustainable water resources management, mainly, the inherent uncertainty associated with the changing climate, the inflexibility in infrastructure and institutions that manage water, and the poor integration of all stakeholders and sectors in water resources management. This study investigates the challenges and opportunities in implementing integrated water resources management and its critical role towards climate change adaptation. A preliminary assessment of sustainable management of water resources and its role in effective climate change adaptation and resilience building in Kenya is carried out through questionnaire survey and stakeholder interactions. Climate change-induced uncertainty, diminishing water sources aggravated by growing water demand, weak institutional and financial governance, and lack of transparency and stakeholder inclusiveness are identified as the main challenging factors that need to be addressed to build a climate resilient society. The study furthermore emphasizes the critical role of water management in achieving Agenda 2030, the Paris Agreement on Climate Change, and the Sendai Framework for Disaster Risk Reduction.

---

**Keywords**

Climate change · Water resources management · Climate change adaptation · Climate resilience · Sustainable development · Agenda 2030

---

**Introduction**

Our climate is changing and is affecting societies and their livelihoods (IPCC 2018). Climate change translates to water crisis in our everyday lives through the increasing uncertainty in water availability, decreasing water quality, and increasing competition over diminishing water resources (UN-Water 2019). According to the World Economic Forum's 2015 assessment of global risks, water crisis was ranked number one with the potential to severely affect poor and vulnerable population across countries and sectors (WEF 2015). As climate change impacts intensify and the populations and their water demands grow, water stress is likely to increase.

The International Food Policy Research Institute has warned the global community that if business-as-usual continues, by 2050, about 4.8 billion people and approximately half of the global grain production will be at risk because of water stress (Water Resources Group 2016). According to FAO (2013), the rate of increase in water use is more than twice the rate of increase in population during the last century. This increase in water use combined with climate change-induced uncertainty in water availability will aggravate the situation of regions that are already under water stress.

This decade marked a surge in global floods and extreme rainfall events by more than 50% with an occurrence rate that is four times higher than in 1980 (EASAC 2018). According to the Organization for Economic Cooperation and Development (OECD) Environmental Outlook (OECD 2012), the number of people at risk from floods by 2050 is estimated to be about 1.6 billion, and the associated economic risk is expected to be around US\$ 45 trillion.

The UN World Water Development Report (WWAP 2019) findings show that the number of people affected and the number of people killed by water-related emergencies such as inadequate water and sanitation, droughts, and flooding are much higher than that due to earthquakes and epidemics and conflicts globally. According to EM-DAT (2019), during the past two decades, floods and droughts have caused more than 166,000 deaths leading to a total economic damage of about US\$700 billion.

In Africa, the increase in floods, droughts, and storms has severely affected the livelihoods of population through lack of safe and clean drinking water, crop failures, food shortages, lack of clean energy, etc. According to the World Bank report (2019), Africa has experienced increasing climate and water risks with more than 2,000 natural disasters since 1970, of which about 1,000 happened in the last decade. According to OECD (2012), between 75 and 250 million people in Africa are projected to be under increased water stress, and agricultural production can reduce by up to 50% in some regions by 2020. The rainfall projections in Africa indicated that Southern Africa will become drier and Eastern and Western Africa will become wetter with increased risk of floods (UNDP 2018). The recent water crisis in South Africa, the food crisis in Sahel, and disastrous cyclones in Mozambique are reminders of society's vulnerability and unpreparedness in the wake of climate change reality, which in most of the cases are aggravated by incompetent institutional and financial capacities.

According to the UN Environment Adaptation Gap Finance Report (UNEP 2018), the global estimates of the costs of climate change adaptation in developing countries are between US\$140 billion and US\$300 billion by 2030 (which is two to three times higher than the earlier estimates cited in the Intergovernmental Panel on Climate Change [IPCC] report). By 2050, the estimates can plausibly be four to five times higher – US\$280 billion to US\$500 billion. For Africa, this would mean that the resources that would have otherwise directed for economic growth, to overcome poverty and to achieve the United Nations Sustainable Development Goals [SDGs] are now to be diverted toward climate change adaptation and resilience building initiatives.

---

## **East African Community and Climate Change Impacts**

Climate model projections for East Africa indicate that rainfall and temperature will become extreme and intense in the future affecting both the quantity and quality of surface and groundwater in the region. This will severely affect the accessibility to

safe and clean drinking water, health, food security, and energy resources (EAC and USAID 2018; Luwesi and Di Luyundi 2019). Adapting to these changes will require not only accurate knowledge of the frequency and severity of the extreme events but also planning and implementation of critical interventions to curb disasters across the East African Community (EAC). Moreover, this is highly important for the smooth implementation of the water targets of the African Union Agenda 2063, the Africa Water Vision 2025, and the 2030 Agenda for Sustainable Development, including the Kenya Vision 2030. The EAC has thus a long way to go for eliminating poverty, hunger, and food insecurity to give its citizens the right to healthy and productive lives.

---

## **Kenya: Country Climate and Water Profile, Climate Change Impacts**

The National Water Policy of Kenya was developed in 1999 and based on that Water Act was established in 2002 (National Water Master Plan 2030 2013). The constitutional reforms of 2010 in Kenya introduced decentralization policy which came into effect in 2013 (Alexis and Lumbasi 2016). Since then the country has undergone significant transition through devolving governance to the 47 newly established counties. Moreover, the country's 2016 Climate Change Act formulated a comprehensive law and policy to guide national and subnational responses to climate change. The Water Resources Management Authority (WRMA) was reformed to Water Resources Authority (WRA) with a mandate that includes regulation, protection, and dissemination of information on water resources. Furthermore, WRA undertakes climate actions in terms of mitigation and adaptation to minimize the effects of global warming and climate change.

With the projected increase in temperature of about 2.5 °C between 2000 and 2050, and with rainfall becoming more intense and less predictable, Kenya is considered as very vulnerable to the impacts of climate change. The arid and semiarid lands (ASALs) in the north and the east of the country are particularly at risk because of the increased occurrence of drought and the associated food and water security challenges. The increased frequency of droughts, floods, and landslides in the Rift Valley Province and the increased floods and saltwater intrusion in the coastal areas are also posing challenges that demands efficient actions at national level to improve the adaptive capacity and resilience of the population (Government of the Netherlands 2019).

About 80% of the country's geographical area is arid or semiarid, and the main source of sustenance is pastoral and subsistence agriculture. The livelihoods of the poor are severely affected by the climate crisis and are having a severe impact on country's socioeconomic development (Mwendwa and Giliba 2012). A questionnaire survey conducted by Mwendwa and Giliba (2012) found recurrent droughts and changes in rainfall patterns to be the most important indicators of the effects of climate change and food shortage, hunger, famine, water scarcity, low yields, and high poverty levels as the most important impacts of climate change in Kenya.

According to Ng'ang'a (2006), the 2004/2005 drought resulted in a prolonged famine in the less rainfall areas in the country. Decreasing lake surface area, for example, in the case of Lake Naivasha, has affected water quality, quantity, and navigability and has affected its biodiversity (Mironga 2005).

In urban areas, the impacts of climate change are visible mainly in informal settlements, where the risks arising from droughts and floods are severe. The risks in rural areas arise because of the dependence of rural population on the increasingly diminishing and degraded water sources. The major challenges faced by the peri-urban and rural population are the limited management capacity and low operating revenues. According to Mureithi et al. (2018), the lack of access to finance is also a major constraint as funding tends to be generally allocated to develop new water systems in very low-income areas with poor access rather than on restoring an already existing but poorly performing water supply scheme.

---

## Wise Water Management Toward Climate Change Adaptation

It is crucial to acknowledge that water is not just a sector that has been impacted by climate change. The central role of water in adapting to the climate change-driven variations has been increasingly recognized over the past decade. However, water's ability to address climate change adaptation still faces many challenges. The inherent uncertainty associated with the changing climate, the inflexibility in infrastructure, and institutions that interact with water, in addition to the lack of an integrated approach in water resources management, are the fundamental challenges that need to be addressed at global, regional, and local scale (UN-Water 2019).

Water is inextricably linked with food and energy. Addressing climate change adaptation through effective water management is an opportunity by which the governance, infrastructure, and financing mechanisms can be transformed, leading to a holistic development of the community. It is highly important that the national policies should reflect on climate change adaptation strategies that are being followed in similar hydroclimatic parts of the world and at the same time incorporate the locally developed adaptation techniques to improve its climate resilience. Increased water stress coupled with increasing future water demands will require tough decisions on how to allocate water resources between competing water uses, including for climate change mitigation and adaptation.

Wise water management can be achieved through effective, efficient, and participatory management of water resources. Scarcity of water leading to drought can be addressed through increased rain water harvesting and water storage to capture the minimal available water at the source. These water harvesting structures will also aid in enhancing groundwater recharge, thereby improving the resilience of the society to future low surface water availability. In order to address the problems of excess water because of floods, the Water Resources Authority is in the process of developing plans to prepare the society towards flood disasters.

Application of innovative climate technology on the ground through sensor data, models, and weather forecasting improved water distribution systems, avoiding

leakages and thereby decreasing loss through nonrevenue water are delivering positive outcomes. According to a recent report (Global Center on Adaptation 2019), researchers at Jomo Kenyatta University of Agriculture and Technology in Kenya in collaboration with Wageningen University and Research in the Netherlands is planning to launch the Climate Atlas, a localized weather monitoring system, with the aim of providing local rainfall and temperature projections across the 47 counties in Kenya for the period 2050–2100. The overall aim of this project is to protect Kenya's food supply for the future years. Another report by UNFCCC (2019) discussed a readiness proposal by Ghana on "Integrated Climate Monitoring and Early Warning System" aimed at strengthening the country's capacity to build an early warning system for droughts. In cities, nature-based solutions through restoration of degraded ecosystems in the buildup areas can improve the adaptive capacity. The city area can be envisaged as a catchment unit, and the effective capturing and managing of stormwater can make the city more resilient.

---

## Climate Resilience Through Water Management

Adapting to climate change after the occurrence of a disaster is a reactive approach. Building resilience on the other hand is the ability to adapt to and transform and recover from that hazard in a timely, efficient, and sustainable manner. The first step towards achieving resilience is to have access to the relevant information, for example, through public campaign or by collaborating with established networks. Participatory vulnerability assessments at grassroots level are critical. Furthermore, resources should be available to make assessment and to ensure and facilitate processes leading to resilience. For instance, one need to prioritize the most critical climate change impact in a region based on the exposure, sensitivity, and adaptive capacity of the population to that impact. Based on that, a monitoring and evaluation system has to be designed and organizational capacity need to be build. Ensuring political commitment as well as facilitating implementation of public private partnerships can aid in short-term development of resilience. The final step is to develop necessary institutional arrangements that support long-term adaptation measures.

In Kenya, the relevant policy and legislative framework has been put in place to guide the country's response to the challenges of climate change. Climate change adaptation and resilience has been set in the National Adaptation Program (NAP) and is operationalized through the National Climate Change Action Plan (NCCAP). This is done by mainstreaming adaptation across all sectors in the national planning, budgeting and implementation processes, and taking cognizant of the fact that climate change is a cross-cutting sustainable development issue with economic, social, and environmental impacts (GoK 2016). The other policy documents include the National Drought Management Authority Act 2016, National Policy for Disaster Risk Management 2013, the National Climate Change Response Strategy (NCCRS) 2010, and the Climate Change Act 2016.

Climate resilience through effective water management can be achieved through sustainable implementation of integrated water resources management. Functional



water governance mechanisms can reduce disasters and build capacity for adaptation and thereby improve resilience. Locally designed and implemented water storage and flood control structures and nature-based solutions, for instance, lakes as natural water storage structures and floodplains as natural excess runoff absorbers, are some examples on climate resilience through wise water management. Healthy ecosystem services are dependent on well-functioning river basins, which in turn can support agriculture and fisheries, wastewater treatment, drinking water provision, groundwater recharge, and coastal protection among others. In Zambia, the natural underground water reservoirs were protected through proper waste disposal, hence improving aquifer health and usage, thereby benefiting the local population in Lusaka (IWA 2019).

Building resilience through empowerment of the climate change-affected community has been reported in many parts of the world. One such example is the Osukuru United Women's Network in Uganda (Global Resilience Partnership 2019). The major climate change impact faced by this community was flooding and the associated displacements and health issues. This women's network initiated campaigns and improved the resilience of the community by building trenches around the houses to prevent floodwater from entering their homes. With more and more people joining this network, the success rate is high. However, there are challenges in the sustainable functioning of the network, for instance, financial viability, capacity building, training, mobility, etc. Enhanced climate resilience thus includes strong economic growth, resilient ecosystems, and sustainable livelihoods. It is noted that through climate financing (Odhengo et al. 2019) and public-private partnerships, there will be opportunities for progress in Kenya

The core approach in building resilience includes creating awareness, building social capital, improving technical capacities, and thereby empowering the community. Community-based vulnerability assessment and development of resilience action plan and promoting joint action through multi-stakeholder groups aid in faster adaptation. Furthermore, by making the livelihood-dependent economies diverse and flexible can also improve the community's resilience to climate change. Knowledge, learning, innovation, and clean technology are key towards achieving climate resilience. Smart agricultural technology such as integrated weather and market advisories inform farmers on what and when to grow and harvest, where to sell their produce, etc.

Questionnaire survey and stakeholder discussions including governmental, non-governmental, and other organizations in Kenya are ongoing. According to the survey results, climate change impacts that are being experienced in the region are manifold – floods, droughts, storms, and its associated impacts on the society and the ecosystem. One major impact is on agriculture and food production, especially on the subsistence farming. Decline in agricultural produce has reduced the marginal GDP in the agriculture sector. This along with the fluctuations in world market prices and changes in geographical distribution of trade regimes has caused an increased number of people at risk of hunger and food security. Extreme weather conditions have affected water supply and water quality, thereby affecting human health. The increased demand coupled with the decreasing supply of source water resources has

led to conflicts over water sharing. The timely dissemination of relevant climate information to the most vulnerable sections of the society is yet another major challenge that needs to be addressed.

The sustainable management of water resources faces major challenges because of climate change-induced uncertainty, diminishing water resources, increased water scarcity, and lack of protection of water sources through regulation. Community engagement and stakeholder participation especially from the vulnerable communities are crucial, and ownership and control of water resources are found to have resulted in more active participation of stakeholders. Incorporation and mainstreaming of innovation and technology are increasingly applied but have more scope for improvement. Climate change adaptation through rainwater harvesting, water storage development, and climate smart agriculture is followed by communities with support from government. The major constraint in the wise management of water resources is the long-term sustainable finance and funding mechanisms.

Kenya has identified climate change and disaster risk management as two of the three thematic areas in their National Plan. The nationally determined contributions (NDC) identify mainstreaming of climate change adaptation in the water sector as one of the priority adaptation strategies (Ministry of the Environment of the Republic of Kenya 2013). Adaptation strategies include development of water resources monitoring and early warning assessments.

---

## **Water: A Cross-Cutting Factor in Agenda 2030 SDGs**

The achievement of Agenda 2030 Sustainable Development Goals are dependent on improved and sustainable water management (UNESCO and UN-Water 2020). There are multiple interlinkages of SDG 6 on water to the other 16 SDGs and also intralinkages within the SDG 6 connecting water and sanitation, water quantity and quality, IWRM, and community engagement in IWRM. The institutional and financial investment in achieving SDG 6 through resilient water management will inherently advance the progress of other SDGs through: overall poverty reduction (SDG 1); water security supporting the food and agriculture sector and thereby eradicating hunger (SDG2); quality water toward good health (SDG3); safe, segregated toilets and menstrual hygiene improves girls' access to education (SDG 4); gender equality in public and working life (SDG 5); access to energy and hydro-power as one solution for sustainable energy (SDG 7); inclusive and productive economic growth and employment through water (SDG 8); resilient and sustainable water infrastructure (SDG 9); reduced inequalities through accelerated and inclusive action on water supply and sanitation (SDG10); sustainable and equitable urban development (SDG 11); equitable use and efficient water resources management (SDG 12); combating climate change impacts through climate-resilient water resources management (SDG 13); water quality and water resources management upstream on the land and along the rivers impacts coastal and marine ecosystem (SDG 14); increasing sustainable management of soil (SDG 15); promoting peaceful societies and accountable and inclusive institutions through effective water

governance (SDG 16); and building commitments and accountability in the water sector, institutional coordination of water programs, mobilizing funding, and improved technology through strengthened means of implementation (SDG 17). Acknowledging the significance of water in these interlinkages and increasing efforts in addressing the challenges to achieve SDG 6 will automatically advance progress in climate change adaptation through wise water resources management and will help build resilient communities.

Although water is not explicitly mentioned in the Paris Agreement or in the Sendai Framework, it is important to acknowledge its relevance in achieving most of the mitigation and adaptation strategies and targets. The United Nations Framework Convention on Climate Change (UNFCCC) assessed the link between climate change and integrated water resources management such as watershed protection, waste- and stormwater management, water conservation, recycling, and desalination (UNFCCC 2019), where water governance is emerging as a leading domain for resilience to climate change.

---

## Conclusion

Climate change primarily impacts society through several disasters, such as floods, droughts, storms, etc. which then severely affects human security and socio-economic development of the region. Building and enhancing resilience to these disasters through effective water management are crucial, and water can play a major role in achieving effective climate change adaptation. Furthermore, disasters are recognized as opportunities to revitalize livelihoods, environment, and economies that can then lead to communities that are more resilient.

Innovative technologies in water supply and management and active participation of civil society, government, and private sectors can improve urban resilience. An integrated water resources management is imperative for attaining both rural and urban resilience as it safeguards their livelihoods and food security. It is also essential to ensure inclusiveness and meaningful participation of all stakeholders and include indigenous adaptation practices and traditional knowledge.

National and regional climate policy and planning should follow an integrated approach to climate change and water management. It is extremely important that the national adaptation strategies assist the vulnerable sections of the society and improve their resilience to the climate change impacts. Furthermore, increased investment is needed in institutions, capacity development, better data collection, assessment, and sharing.

---

## References

- Alexis S, Lumbasi L (2016) The impact of decentralization in Kenya, Trinity College London, Masters in Development Practice 2016, AidLink enabling communities in Africa tackle poverty
- EAC, USAID (2018) Climate change vulnerability and adaptation in East Africa, current and future climate change. [https://www.climatelinks.org/sites/default/files/asset/document/2018\\_USAID-](https://www.climatelinks.org/sites/default/files/asset/document/2018_USAID-)

- PREPARED-TetraTech\_VIA-East-Africa-Current-Future-CC-Factsheet.pdf. Accessed 27 Mar 2019
- EASAC (European Academies' Science Advisory Council) (2018) Extreme weather events in Europe: preparing for climate change adaptation: an update on EASAC's 2013 study. <https://easac.eu/publications/details/extreme-weather-events-in-europe/>
- EM-DAT (Emergency Events Database) (2019) The emergency events database. Centre for Research on the Epidemiology of Disasters (CRED), Université catholique de Louvain, Brussels. [www.emdat.be](http://www.emdat.be)
- FAO (2013) Coping with water scarcity: an Action framework for agriculture and food security. FAO water reports no. 38. FAO, Rome. [www.fao.org/3/a-i3015e.pdf](http://www.fao.org/3/a-i3015e.pdf)
- Global Center on Adaptation (2019) How mapping changes on a local level will help Kenyan farmers. [https://gca.org/solutions/how-mapping-changes-on-a-local-level-will-help-kenyan-farmers?utm\\_sq=g9atrsd0w0](https://gca.org/solutions/how-mapping-changes-on-a-local-level-will-help-kenyan-farmers?utm_sq=g9atrsd0w0). Accessed 27 Mar 2020
- Global Resilience Partnership (2019) Thriving in the face of surprise, uncertainty and change, Resilience Insights 2019. <http://grpinsightsreport.info/>. Accessed 31 Oct 2019
- GoK (2016) Kenya National Adaptation Plan: 2015–2030, Enhanced climate resilience towards the attainment of Vision 2030 and beyond, Government of Kenya, July 2016.
- Government of the Netherlands (2019) Climate change profile, Kenya. Report by the Ministry of Foreign Affairs, Government of the Netherlands.
- IPCC (2018) Summary for policymakers. Global warming of 1.5°C. An IPCC special report on the impacts of global warming of 1.5°C above pre-industrial levels and related global greenhouse gas emission pathways, in the context of strengthening the global response to the threat of climate change, sustainable development, and efforts to eradicate poverty. IPCC, Geneva. [www.ipcc.ch/sr15/chapter/spm/](http://www.ipcc.ch/sr15/chapter/spm/)
- IWA (2019) Nature-based solutions: the advantage of being a developing country. <https://iwa-network.org/nature-based-solutions-the-advantage-of-being-a-developing-country/>. Accessed 30 Oct 2019
- Luwesi CN, Di Luyundi TM (2019) A quick appraisal of the impact of environmental changes on undernutrition in Kenge Health Zone, DRC. *Biomed J Sci Techn Res* 18(3):19–26. <https://doi.org/10.26717/BJSTR.2019.18.003145>
- Ministry of the Environment of the Republic of Kenya (2013) The National Water Master Plan 2030. The Republic of Kenya. <https://wasreb.go.ke/national-water-master-plan-2030/>
- Mironga JM (2005) Environmental implications of water hyacinth infestation in Lake Naivasha, Kenya. In: 11th World lakes conference, Nairobi, Kenya, 31st October to 4th November 2005, Pp: 580 - 592, Proceedings Volume II, Ministry of Water and Irrigation International Lake Environment Committee.
- Mureithi PM, Luwesi CN, Mutiso MN, Förch N, Nkpeebo AY (2018) Legal and market requirements for water finance. In: Beyene A, Luwesi, CN (eds) Africa: the Kenya water sector reforms case in innovative water finance in Africa, A guide for water managers, volume 1: water finance innovations in context. The Nordic Africa Institute, Uppsala, Sweden.
- Mwendwa P, Giliba RA (2012) Climate change impacts and adaptation strategies in Kenya. *Chin J Popul Resour Environ* 10(4):22–29. <https://doi.org/10.1080/10042857.2012.10685104>
- National Water Master Plan 2030 (2013) The project on the development of the National Water Master Plan 2030, final report volume 1, Executive summary
- Ng'ang'a JK (2006) Climate change impacts, vulnerability and adaptation assessment in East Africa, UNFCCC African regional workshop on adaptation, 21–23 September 2006, Accra
- Odhengo P, Atela J, Steele P, Orindi V, Imbali F (2019) Climate finance in Kenya: review and future outlook, discussion paper
- OECD (2012) OECD environmental outlook to 2050, OECD Publishing. <https://doi.org/10.1787/9789264122246-en>. Accessed 30 Oct 2019
- UNDP (2018) Climate change adaptation in Africa, UNDP synthesis of experiences and recommendations. UNDP/GEF, New York
- UNEP (2018) The adaptation gap report 2018. United Nations Environment Programme (UNEP), Nairobi, Kenya. <https://www.unenvironment.org/resources/adaptation-gap-report>

- UNESCO, UN-Water (2020) United Nations World Water Development report 2020: water and climate change. UNESCO, Paris
- UNFCCC (2019) How developing countries are scaling up climate technology action, Article 19 Nov 2019. <https://unfccc.int/news/how-developing-countries-are-scaling-up-climate-technology-action>
- UN-Water (2019) Climate change and water, UN-Water policy brief. <https://www.unwater.org/publications/un-water-policy-brief-on-climate-change-and-water/>. Accessed 28 Oct 2019
- Water Resources Group (2016) Annual report, Partnerships for transformation, water security partnerships for people, growth and the environment
- WEF (2015) Global risks 2015, 10th edn. World Economic Forum. [http://www3.weforum.org/docs/WEF\\_Global\\_Risks\\_2015\\_Report15.pdf](http://www3.weforum.org/docs/WEF_Global_Risks_2015_Report15.pdf). Accessed 18 Nov 2019
- World Bank (2019) This is what it's all about: building resilience and adapting to climate change in Africa. [https://www.worldbank.org/en/news/feature/2019/03/07/this-is-what-its-all-about-building-resilience-and-adapting-to-climate-change-in-africa?cid=EXT\\_WBEmailShare\\_EXT](https://www.worldbank.org/en/news/feature/2019/03/07/this-is-what-its-all-about-building-resilience-and-adapting-to-climate-change-in-africa?cid=EXT_WBEmailShare_EXT). Accessed 31 Oct 2019
- WWAP (2019) The United Nations World Water Development report 2019, Leaving no one behind, UNESCO World Water Assessment Programme. UNESCO, Paris

**Open Access** This chapter is licensed under the terms of the Creative Commons Attribution 4.0 International License (<http://creativecommons.org/licenses/by/4.0/>), which permits use, sharing, adaptation, distribution and reproduction in any medium or format, as long as you give appropriate credit to the original author(s) and the source, provide a link to the Creative Commons license and indicate if changes were made.

The images or other third party material in this chapter are included in the chapter's Creative Commons license, unless indicated otherwise in a credit line to the material. If material is not included in the chapter's Creative Commons license and your intended use is not permitted by statutory regulation or exceeds the permitted use, you will need to obtain permission directly from the copyright holder.





# Impacts of Environmental Change on Fish Production in Egypt and Nigeria: Technical Characteristics and Practice

# 42

M. L. Adeleke, D. Al-Kenawy, A. M. Nasr-Allah, M. Dickson, and Desalegn Ayal

## Contents

Introduction .....	790
Methodology .....	791
The Study Area .....	791
The Design .....	794
Sample and Sample Techniques .....	794
Data Collection Tools .....	795
Results and Discussion .....	795
Socioeconomic Characteristics of Fish Farmers in Egypt and Nigeria .....	795
Technical Characteristics of Fish Farming System and Operation in Egypt and Nigeria .....	796
Environmental Changes Impacts on Fish Production in Egypt and Nigeria .....	799
Conclusion and Recommendations .....	803
References .....	804

This chapter was previously published non-open access with exclusive rights reserved by the Publisher. It has been changed retrospectively to open access under a CC BY 4.0 license and the copyright holder is “The Author(s)”. For further details, please see the license information at the end of the chapter.

M. L. Adeleke (✉)

Department of Fisheries and Aquaculture Technology, The Federal University of Technology, Akure, Akure, Nigeria

e-mail: [mladeleke@futa.edu.ng](mailto:mladeleke@futa.edu.ng); [mosunmolalydia@yahoo.com](mailto:mosunmolalydia@yahoo.com)

D. Al-Kenawy · A. M. Nasr-Allah · M. Dickson  
WorldFish, Abbassa, Abou-Hammad, Sharkia, Egypt

D. Ayal

Center for Food Security Studies, College of Development Studies, Addis Ababa University, Addis Ababa, Ethiopia

© The Author(s) 2021

W. Leal Filho et al. (eds.), *African Handbook of Climate Change Adaptation*,  
[https://doi.org/10.1007/978-3-030-45106-6\\_153](https://doi.org/10.1007/978-3-030-45106-6_153)

789

---

**Abstract**

A survey approach was applied to examine the technical characteristics of fish farming practice in Egypt and Nigeria. Critical issues such as floods and other vices were considered in bringing out the inference and level of aquaculture in both countries. Multistage sampling technique was used to select the study area and the number of respondents. Both primary and secondary data were used in the analysis. Eighty fish farmers were randomly selected from each of the country, making a total of 160 respondents. The socioeconomic characteristics revealed that aquaculture is an antique venture in Africa with Egypt taking the lead, i.e., 99% of the respondents practice in large-scales production of more than 11 Fadden/acre per, and 100% males depend mainly on agricultural drainage water for their earthen ponds. Ninety-eight percent cultured tilapia (*Oreochromis niloticus*) which was believed to have originated from the Nile River. In terms of financial performance and partial economic analysis, tilapia production commands more sales in Egypt, while catfish (*Clarias*) production is seen as a promising venture in Nigeria. The fish farmers have various perceptions and reactions toward environmental changes factors such as cost of labor/manpower and inputs, poor water quality, and fish extension services, and climate change impedes aquaculture development in the countries. To achieve the scale of aquaculture expansion as observed in Asian and other developed part of the world, efforts should be geared toward continental and regional integration in order to encourage aquaculture practices in Nigeria and other parts of Africa. More so, government intervention and incentives should be paramount in Egypt to reduce the excessive exploitation of the private input suppliers.

---

**Keywords**

Technical · Environmental · Fadden · Tilapia and catfish

---

**Introduction**

Aquaculture is an organized process in which the cultivation of aquatic animals and plants in fresh, brackish, and marine water is made, to increase fish production above the level that would be produced naturally (FAO 2016). Fish is the most-traded food commodities worldwide; more than 3.1 billion people depend on it for their average per capita intake of animal protein which is about 20%. Aquaculture has increased the world per capita fish supply to 20 kg in 2014 (FAO 2016). Global fish forecast model predicts that the share percentage of capture fisheries is expected to fall by half in 2030 compared to the 60% global production in 2011 after growing only by 2.8 million. Aquaculture is expected to grow by 30 million tons over this same period. In terms of food fish production, the model predicts that aquaculture will contribute 62% of the global supply by 2030 (FAO 2016). The problem of feeding the more than 9 billion people in the world by 2050 in the context of climate change

and uncertainty (World Bank 2013) will be rightly addressed if improved aquaculture management is adhered.

Aquaculture seems to be multilocational and isolated. The Egyptians were probably the first in the world to culture fish as far back as 2500 B.C. from Japanese Resource Council, Science and Technology Agency as cited in Jhingran (1987). Aquaculture production in Egypt far exceeds that of the rest of the other Africa countries. It is a 2.2 billion USD in 2015. Egyptian aquaculture currently provides almost 79% of the country's fish needs, with almost all the output coming from small- and medium-sized privately owned farms (GAINS 2015).

Aquaculture was introduced into Nigeria in the 1950s. Recently, it is one of the fastest growing agricultural enterprises in the country. It impacted the nation's economy in terms of contributing over 1 million metric tons to Gross Domestic Product (GDP). It is best alternatives to meet protein demand; it is a business with brighter opportunities. Despite the fact that aquaculture is an age-old practice in some regions of the world, it is relatively new in most African countries and is significant to the economic, livelihood, and nutritional welfare of the populace. From all indications, Egypt has the largest aquaculture industry in Africa (Sumaila et al. 2014).

Therefore, the research questions, what are the technical factors to be considered in order to shrink the disparities? And environmental changes impact on fish production in Africa. This chapter classically, therefore, examines the technical characteristics of fish farming (Aquaculture) practice and impacts of environmental change on fish production in Egypt and Nigeria. Specifically, the socioeconomic characteristics of the respondents were determined using Kobocollect, fish farming system and operation were examined, and critical issues and institutional framework were considered bearing in mind the fish farmers' awareness on environmental changes.

---

## Methodology

### The Study Area

Egypt (see Fig. 1) is located between 30° 06' N and 31° 25' E. Based on the US estimates, the current population of Egypt is 94,660,721 which is equivalent to 1.27% of the total world population (Worldometers 2017), and the total land area is 995,560 km<sup>2</sup> (384,388 sq. mi). The climate is arid where most of the rains fall in the winter months with an average of 2–5 mm (0.1–0.2 in)/year with the exception of the Northern coast which sometimes can be as high as 410 mm (16.1 in) between the period of October and March (Worldometers 2017). The temperature range from 49.1 °F to 73.4 °F in low wind and sometimes average high temperatures vary from 62.6 °F in wintertime to 89.6 °F in summertime were recorded.

The Nile is the primary water source of Egypt and provides more than 95% of all water available to the country. Over 60 million people are connected with the agricultural sector which constitutes 20% of GDP and consumes about 80% of the

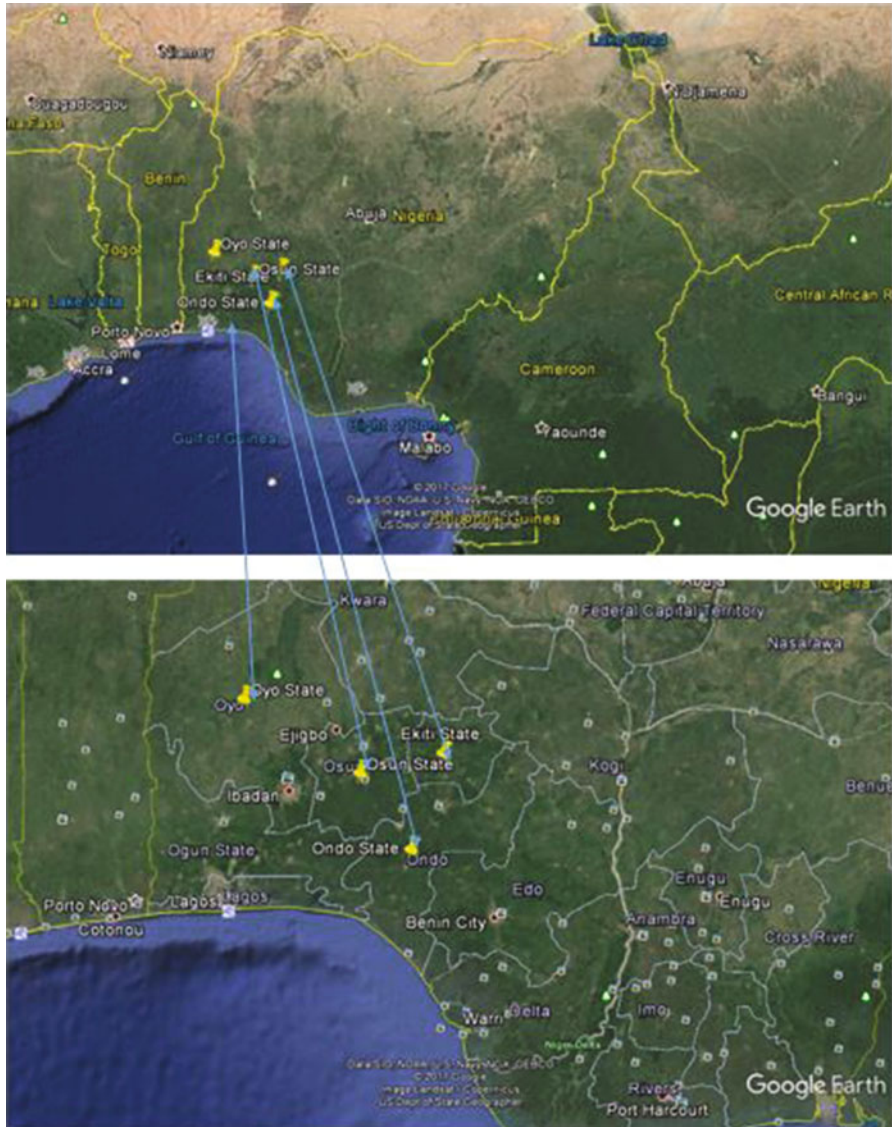




**Fig. 1** Google Earth Map showing the study area in Egypt. (Source: Authors creation, 2017)

water budget. Aquaculture in Egypt is supported by water from irrigated agriculture and lakes such as lakes Burullus, Manzala, and Idku all located in Egypt.

Nigeria (see Fig. 2) lies exclusively within the tropical zone in West Africa. It borders with the Republic of Benin in the west, Chad and Cameroon in the East, and Niger in the North. The current population is 190,423,532 which is equivalent to 2.55% of the total world population and ranked 7th in the list (Worldometers 2017). The total land area is 910,802 km<sup>2</sup> (351,662 sq. mi) with 9° 82' 00" N; 8° 67' 530" E coordinates (see Fig. 2). The northeast and southwest winds are the two principal wind currents that make Nigeria to be distinguished with two distinct seasons: a wet season from April to October, with generally lower



**Fig. 2** Google Earth Map showing the study area in Nigeria. (Source: Authors creation, 2017)

temperatures, cloudy and rainy weather upshot of the southwest wind current. There are wide climatic variations in the country depending on the season and region. Nigeria got her name from the river, Niger River. Nigeria is indeed blessed with marine, brackish, and freshwater in addition to lakes, rivers, deltas, reservoirs, dams, rain, floodplains, inland, and coastal waters to support fisheries and aquaculture in the country.

## The Design

In this research, explanatory mixed research design was applied to address specific objectives of the research work. The selected research design allows to collect data from different sources using various data collection tools. Quantitative data were collected using semi-structured and open-ended questions from key informants. Focus Group Discussion (FGD) checklists were also used to collect data. While, quantitative data was collected using questionnaire survey from the sampled fish farmers households. The questionnaire was used to collect data on the socioeconomic characteristics of the respondents, technical characteristics of the fish farms, the critical issues (water shortage, water quality, floods, and other vices), institutional framework, and respondents' perceptions of the environmental changes. Experienced male (six) and female (six) enumerators were recruited and trained.

## Sample and Sample Techniques

A multistage sample technique was used to select the study area and respondents. Egypt and Nigeria were purposely selected because of the green and blue water-type availability for aquaculture, respectively. In Egypt, Kafr El Sheikh (KFS), Bahera, Shakia, and Port Said Governorates were purposely selected due to their aquaculture practice. Likewise in Nigeria, Ekiti, Ondo, Osun, and Oyo states were selected purposely in southwest of the country. This is because the states are in the same geopolitical zones. In the Egypt and Nigeria sites, a total of 160 fish farmers' households were selected using proportional random sampling method (see Table 1). The data collection was carried out between January and April, 2017, in Egypt and Nigeria.

**Table 1** Distribution of questionnaire survey participants sample fish farmer households

No.	Egypt			Nigeria		
	Site	Total fish farmer households	Sample size	Site	Total fish farmer households	Sample size
1.	Kafr El Sheikh	35	35	Ekiti state	20	20
2.	Bahera	15	15	Ondo state	20	20
3.	Shakia	15	15	Osun state	20	20
4.	Port Said	15	15	Oyo state	20	20

Source: Authors Computed Field Survey

## Data Collection Tools

Data collections were done by a six paired (male and female) trained enumerators who were trained on the use of Kobocollect and questionnaire administration. Data collections were done using Kobocollect application on the tablets/IPhones; in some cases, structured questionnaires, the completed questionnaire, were later keyed into the Kobocollect. Interview schedule and Focus Group Discussions (FGD) were also employed to get responses from the fish farmers in accordance to the set objectives and scope of the research work. KoboToolBar supported the participants to collect data online and offline especially during a logistical constraint. It gives room for backed up into secure servers. The questionnaire with similar content was prepared in two languages: English and Arabic. The English version was administered in Nigeria, while the Arabic version was administered on the respondents in Egypt.

---

## Results and Discussion

### Socioeconomic Characteristics of Fish Farmers in Egypt and Nigeria

The results of the Kobocollect analysis of the fish farmers' socioeconomic characteristics are presented in Table 2.

**Gender:** refers to the socially built characteristics such as norms, roles, and relationship of and between groups of women and men (male or female). Like age classification, it also varies from society to society. The result showed that the percentage of male fish farmers in Nigeria was 93% and that of the female was 7%. Though, this chapter revealed there was no female fish farmers in Egypt. This suggests that females might have been involved in other activities apart from fishing. The result also revealed that more males were in aquaculture than the females in both countries. This might be due to the fact that aquaculture production is more of manual labor/blue-collar job in which more physical energy are required. They are also likely to be involved in other fish farming activities like processing and marketing couple with their home cares which were sometimes uncounted (Adeleke 2013). The result also agrees with the study of Olufayo (2012); Adeleke and Fagbenro (2013) that women participate not only in the traditional fisheries sectors of fish processing and marketing but also in the nontraditional sectors of aquaculture, fisheries research, education, and extension.

**Fish farming as main occupation:** In Egypt, 89% of the respondents took fish farming as the main occupation, whereas the rest (11%) considered it as their secondary occupation. On the other hand, the result revealed that 41% of the respondents in Nigeria ranked fish farming as the main occupation, while majority (59%) chose it as the secondary occupation; other occupation engaged by the respondents in the study areas were civil servant, trading, carpentry, tailoring, teaching, agribusiness, and driver. This suggests that aquaculture in Nigeria is still

**Table 2** Socioeconomics characteristics of the fish farmers in Egypt and Nigeria

Category or variable	Egypt	Nigeria
	Frequency (%)	Frequency (%)
<b>Gender</b>		
Male	79 (100.0)	74 (92.5)
Female	–	6 (7.5)
Total	79 (100.0)	80 (100.00)
<b>Fish farm as main occupation</b>		
Yes	70 (88.6)	33 (41.25)
No	9 (11.4)	47 (58.75)
Total	79 (100.0)	80 (100.00)
	<b>Mean ± S.E.</b>	<b>Mean ± S.E.</b>
Fish farming experience (years)	18.6 ± 1.10	6.46 ± 1.22
Farm distance from residents (km)	22.27 ± 6.41	4.7 ± 1.07
Number of household	6.28 ± 0.34	4.57 ± 2.83
Number of children under 18 years	2.96 ± 0.24	1.4 ± 1.17
Number of adult above 60 years	0.19 ± 0.07	0.41 ± 0.29
Number of male in the household	3.27 ± 0.19	2.36 ± 2.46
Number of female in the household	3.00 ± 0.21	2.2 ± 1.67

Source: Authors Computed Field Survey

at the developmental stage. Aquaculture production in Nigeria at present is fairly insignificant at 5000 tons/year (FAO 2000). FAO estimates that this could be increased to about 650,000 tons. Recent researches showed that aquaculture in Nigeria has potential to contribute to both food security and economic development of the country but is still in a promising business. Despite the fact that aquaculture is an age-old practice in Egypt, it is still contributing immensely to the country's GDP, employment, and food security as it is doing relatively in most countries and is significant to the economic, livelihood, and nutritional welfare of the populace.

### Technical Characteristics of Fish Farming System and Operation in Egypt and Nigeria

Parameters such as scale of operation, types of pond, source of water, access to water, water quality parameters, types of fish produced/cultured species, fish with highest production and demand, venture profitability, continuity, and inputs sources were considered. The results were analyzed and presented accordingly.

*Scale of operation and purpose for rearing fish:* The study revealed that small-, medium-, and large-scale farming operations were practiced in the study areas (see Table 3). The scale of operations determined the purpose of rearing fish as designated by this study. Small-scale production implies for household consumption; medium-scale production is meant for household consumptions and sales, while large-scale production does mean for fully commercial/industrial/exports. The

**Table 3** Technical characteristics of fish farming system and operation in Egypt and Nigeria

Indicators	Egypt	Nigeria
	Frequency (%)	Frequency (%)
<b>Purpose for rearing fish</b>		
Small scale (household)	–	50 (62.5)
Medium scale (household and sales)	1 (1.3)	24 (30.0)
Large scale (commercial/industrial/exports)	78 (98.7)	6 (7.5)
Total	79 (100)	80 (100)
<b>Types of pond</b>		
Earthen ponds	78 (98.7)	70 (87.5)
Others (concrete, plastic, collapsible tanks, vats)	1 (1.3)	10 (12.5)
Total	79 (100)	80 (100)
<b>Source of water</b>		
Stream	–	29 (36.25)
River	5 (6.3)	9 (11.25)
Groundwater/well/boreholes	–	28 (35.0)
Rain catchment/reservoirs	–	16 (20.0)
Lake water	10 (12.7)	–
Agricultural drainage water	61 (77.7)	–
Mixed drainage and Nile water	3 (3.8)	–
Total	79 (100)	80 (100)
<b>Problems as regards the water source</b>		
Yes	63 (79.7)	33 (41.25)
No	16 (20.3)	47 (58.75)
Total	79 (100)	80 (100)
<b>Have you taken precautionary measures</b>		
Yes	45 (57.0)	21 (26.25)
No	34 (43.0)	59 (73.75)
Total	79 (100)	80 (100)

Source: Authors Computed Field Survey

results revealed that none of the respondents in Egypt practice small-scale fish production; only 1% of them were operating their farms on medium scale, while 99% operate more than ten Fadden. This shows that fish production in Egypt is in a large-scale operation.

On the other hand, 63% and 30% in Nigeria represented those that operate their fish farms on small scale and medium scale, respectively, while only 7% operated their fish farms on a large scale. The result also revealed that aquaculture in Nigeria is in small scale (93%) as compared to Egypt. The result indicates that fish farming operation in Nigeria is still at the subsistence level where production is mainly for the households with little or nothing for the market/sale. This implies that Nigeria will depend on import of fish to meet the demand of the common people.

The result supports that Egypt has achieved the scale of expansion and growth in aquaculture (Adeleke and Matthias 2017). Hence, aquaculture in Egypt is a 2.2 billion USD a year industry and has been supporting the country's GDP in recent

years, making it the ninth largest global aquaculture producer in 2012 and by far the largest in Africa and the Middle East (FAO 2016). Efforts should be geared toward encouraging and promoting aquaculture practices in Nigeria in order to meet the demand of the households and consumers. Large-scale production should also be encouraged in order to expand the local and international market.

*Types of pond:* 99% of the fish farmers in Egypt cultured their fish in earthen ponds, while in Nigeria, 88% cultured their fish in earthen ponds. One percent and 12% of the fish farmers in Egypt and Nigeria, respectively, represent other types of ponds such as concrete, plastics, collapsible, and fiber tanks and vats. The results of the study revealed that earthen ponds are commonly used in both countries. The percentages of other types of ponds like plastics or tanks are more in Nigeria (12%) than in Egypt (1%). Because of the culture and environment, tilapia is most commonly grown fish species in Egypt. It can do well in earthen ponds where natural food is required; it cannot survive in very low or too high temperature. In contrast in Nigeria, catfish can be raised in an enclosure or tanks where it can thrive, and no artificial aeration is required, but artificial food is required for the survival of the enclosed fish. It implies that ponds type is a very vital parameter to be considered in aquaculture business.

*Source of water:* the results of the study revealed that fish ponds can get water from various water sources depending on the availability, location, and law. In Egypt, the following water sources and percentages were identified: lake (13%), river (6%), agricultural drainage water (78%), and mixed drainage and Nile (45%). It was observed that most of the fish farmers relied on agricultural drainage water. The result is not far-fetched from the fact that aquaculture is the last user of water in Egypt because it made use of reused water. According to the water policy in Egypt. On the other hand, the percentages of the sources of water in Nigeria are represented as follows: 36% stream, 11% river, 35% groundwater/boreholes, and 20% rain catchment/reservoirs. It was observed that in Nigeria, most of the water was fresh-water sources; this also determined the type of fish to be cultured.

Apparently Egypt represents a good example of a green aquaculture because 78% of the fish farmers depend solely on agricultural drainage water while Nigeria is good representation of a blue aquaculture because the water sources were mainly fresh water hence, the type of fish to be cultured. In Egypt, recent research showed that the use of aquaculture drainage water for agriculture is better preferred to the existing practice of agriculture drainage water for aquaculture. The use of aquaculture drainage water is best practice due to its numerous advantages. Aquaculture drainage water contained a lot of nutrients for the crops than the agricultural drainage water which might at the same time not be good for the cultured fish. Efforts should be geared to convince the government in Egypt to pay more attention to the reused of aquaculture drainage water for effective and maximum utilization of water in the country. Eighty percent (80%) of the fish farmers in Egypt that the source/s of the water to their farms/ponds is/are challenging while only 20% believe the source/s of water is/are good and not challenging (Table 3). Despite the natural and blue water sources in Nigeria, 41% believed the water source/s posed a serious problem to their fish farms, while 59% were comfortable with the water source/s to their fish farms.

In Egypt, the problem that was highlighted and emphasized mainly on water sources was pollution, while in Nigeria, the problem was water shortage as a result of dry season. In Egypt, 57% of the respondents have taken precautionary measures as regards reducing the effect of pollution on the water source that enters their farms by checking the water qualities, filter the water when pumping, treatment of water and pond, but 43% are yet to take any precautionary measures. The reason might be due to the fact that they are constrained to the available water source to be used for aquaculture in the country. In Nigeria, 60% of the fish farmers have alternative source of water such as getting water from other ponds, buying water from water tankers, damming of stream water to pump into the pond, boreholes, or well, and reducing stocking density, to their fish farms during dry season in Nigeria, while 40% of the fish farmers have not taken any precautionary measures. The reason might not be far-fetched from the facts that most of the fish farmers in Nigeria practice on subsistence level, and lack of capital is also a limiting factor from the Focus Group Discussion (FGD). Freshwater is the major water source in Nigeria and there are no restriction as to the use of water in the country, is a great opportunity and advantage for citizens who are willing to practices aquaculture to really venture into it because aquaculture is “no restriction of person.”

## **Environmental Changes Impacts on Fish Production in Egypt and Nigeria**

Table 4 presents the impacts of environmental changes on aquaculture in the study areas. The study revealed that 76% of the fish farmers in Egypt were aware of the environmental changes and its impacts on aquaculture. From the FGD, the fish farmers highlighted some observed effect of environment change on the fish production in their countries. In Egypt, the following were highlighted: reduction in rain and increase in level of temperature particularly during summer period (July); movement of the fish in the pond; sudden suffocation/floating of fish and death; low oxygen; extreme cold during winter; increase rate of fish mortality; weather change; negative change in fish feeding habit; observable differences in weather temperature; breeding time changes as the weather changes; outbreak of diseases that affect the fish resulting into fish death; sudden death of fish without reasons; change in climate in Europe; appearance of disease; increase humidity; and extreme temperature. While in Nigeria, change in raining pattern and hot temperature; pollution of air; observation of weather change; reduction in water level; negative change in fish feeding habit; flood; present of climate that is affecting hatchery; and changes in fish habit were the observed environmental changes in aquaculture practice in the country.

The research presented the evidences that there were similarities and disparities in environmental changes manifestations in both countries. The level of environmental changes' awareness of the respondents in both countries might be as a result of their level of education (Table 2). Education gave them edge on the changes that are occurring in their environment either positively or otherwise. It implies that



**Table 4** Environmental changes impacts on fish production in Egypt and Nigeria

Parameters	Egypt	Nigeria
	Frequency (%)	Frequency (%)
<b>Do you have idea of what climate change means</b>		
Yes	60 (76)	76 (95)
No	19 (24)	4 (05)
Total	79 (100.0)	80 (100.0)
<b>Time to first experience the change</b>		
<i>Value (years)</i>		
0–5	46 (58.3)	38 (47.5)
6–10	10 (12.7)	11 (13.8)
11–20	3 (3.8)	3 (3.8)
21–30	–	3 (3.8)
31 and above	20 (25.4)	25 (31.3)
Total	79 (100.0)	80 (100.0)
<b>Means of environmental changes awareness</b>		
<i>Value (source)</i>		
Media	29 (36.7) <sup>a</sup>	66 (82.5) <sup>a</sup>
History	64 (81.0) <sup>a</sup>	53 (66.3) <sup>a</sup>
Personal observation and fish farming experience	–	10 (12.5) <sup>a</sup>
Workshop/studies	–	5 (6.3) <sup>a</sup>
Total	79 (100.0)	80 (100.0)

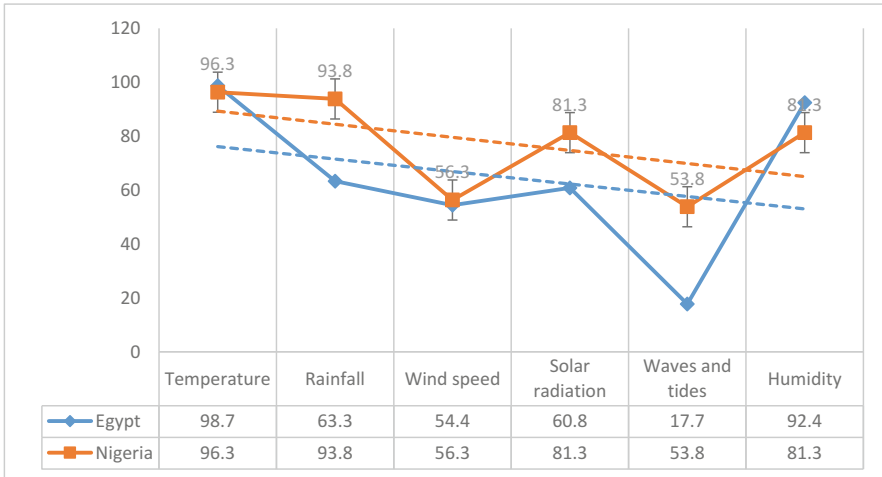
Source: Authors Computed Field Survey

<sup>a</sup>Multiple responses

respondents in both countries are acquaintance with the changes in their environments (Maddison 2007; Nhemachena et al. 2014). Respondents' multiple responses on other means of environmental changes' awareness might not be unlikely from the global climate change program going round the world because it has brought much anxiety to all countries of the world, hence, the multiple responses.

### Environmental Changes Parameters in the Study Areas

Some environmental parameters such as temperature, rainfall, wind speed, solar radiation, waves and tides, and relative humidity were further considered in the study to ascertain their effect on aquaculture practice and production in both countries. The result revealed that 99% of the fish farmers in Egypt were aware of the change in environment as a result of temperature. Sixty-three percent ascertained that rainfall pattern and volume has also changed in the country. Fifty-four percent believed that there are changes in the environment as a result of the change in wind speed. Also, 61% perceived that the change in solar radiation has affected the environment and impacted their fish production. Waves and tides are other environmental parameters that 18% of the fish farmers in Egypt perceive it change and effect on fish production. Also, 92% of the respondents further ascertained the fact that changes in relative humidity have impacted their fish production.



**Fig. 3** Environmental changes parameters in the study areas. (Source: Authors Computed Field Survey)

In Nigeria, 96% of the respondents ascertained that temperature change is an environmental factor that affects their fish production in the country. Ninety-four percent perceived change in rainfall pattern and volume, 56% perceived change in wind speed, 81% perceived change in solar radiation, and 54% perceived change in waves and tides, while 81% also perceived change in relative humidity as environmental factors that have change in recent years (Fig. 3 and Table 4).

The FGD revealed the effects of these environmental parameters on fish production in both countries. Death of fish/mortality; reduction in fish production/growth rate; frozen of fish in winter/low temperature; rise in cost of inputs; and weakness/low appetite in fish were observed in Egypt. Some of the measures taken by the fish farmers to alleviate the adverse effect of the environmental changes were to improve their management practices and also change their production season as the environment is changing. The effects on aquaculture as expressed by the fish farmers in Nigeria were as follows: low fish production; low feeding in fish; reduction in fish growth rate; more stress for farmers; color of water changes; flooding; and death of fish. Based on the Focus Group Discussion (FGD), the following measures were adopted by the fish farmers in Nigeria change feeding formula/pattern and time, low stocking, pumping or alternative water sources, constant change of water, study/observe the weather before feeding, minimize feeding in the morning and more in the evening, stop stocking, freshwater and good feeding, removing fish to the other ponds and applying alternative means.

**Critical Issues on the Study**

*Change in fish production in recent years in the study areas:* Change here means positive or negative, increase/decrease, and adverse/mild depending on the previous position of operation of the fish farms/farmers. In Egypt, 96% confirmed that there

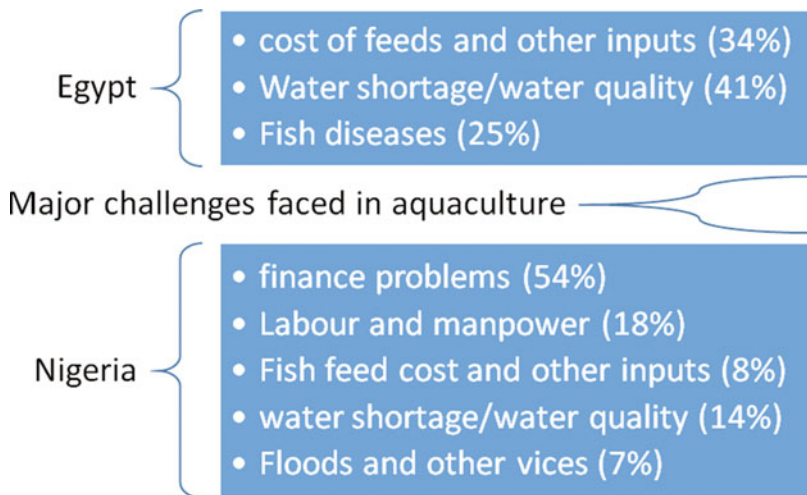
has been change in fish production in recent years. This might have been to the various problems such as change in climatic factors which have direct impacts on fish production and pollution of water to the fish farms (agricultural drainage water). The chapter reveals that, climate change affects and impacts agricultural crops, the end users of the irrigated water will suffer directly or indirectly from the effects. Policy makers should look into the plight of the fish farmers in the country and make available use of other means of water to aquaculture. In the contest of Nigeria, the fish farmers (71%) did not affirm any serious problems during the course of this study. The reason might be to the fact that aquaculture is still at a promising stage which is best described as the first stage of production (stage 1) where there are still increasing rate of returns (IRR).

Other critical issues observed from the study as presented in Table 5. Most of the respondents (92% in Egypt and 79% in Nigeria) do not belong to any cooperative society. Bearing in mind the numerous advantages of belonging to a group, unlike in other section of agriculture, e.g., the Cocoa Farmers Association in Nigeria. In addition, the fish farmers in both countries were deprived of the benefits of the

**Table 5** Critical issues

Parameters	Egypt	Nigeria
	Frequency (%)	Frequency (%)
<b>Has there been any change in fish production in recent years</b>		
Yes	60 (95.9)	23 (28.75)
No	19 (24.1)	57 (71.25)
Total	79 (100.0)	80 (100.0)
<b>Does your fish production meet the demand of the consumers</b>		
Yes	35 (44.3)	44 (55.0)
No	44 (65.7)	36 (45.0)
Total	79 (100.0)	80 (100.0)
<b>Major challenges faced in fish farming</b>		
Finance	–	43 (53.75)
Labor/man power	–	14 (17.5)
Fish feed cost and other inputs	27 (34.2)	6 (7.5)
Water shortage/water quality	32 (40.5)	11 (13.75)
Fish disease	20 (25.3)	–
Vices (thief and flood)	–	6 (7.5)
Total	79 (100.0)	80 (100.0)
<b>Do you belong to any cooperative society</b>		
Yes	6 (7.6)	17 (21.25)
No	75 (92.4)	63 (78.75)
Total	79 (100.0)	80 (100.0)
<b>Do you have access to extension agents</b>		
Yes	17 (21.5)	8 (10.0)
No	62 (78.5)	72 (90.0)
Total	79 (100.0)	80 (100.0)

Source: Authors Computed Field Survey



**Schematic 1** Major challenges faced in aquaculture in the study areas

extension agents as revealed by the results of the study: Egypt 76% while Nigeria 90%. These issues were observed as critical; hence, urgent or future attention should be provided in order to protect the future strides of aquaculture in both countries.

*Major challenges faced in aquaculture in the study areas:* The cost of fish feeds and other inputs contributed to the challenges facing aquaculture; 34% of the fish farmers established this fact. The result buttressed the dependence on private input suppliers who supplied most of the fish farmers on credit and later get all the gains/profit of the fish farmers; hence, the fish farmers have no say in his farm. That is why most of the fish farmers wanted to quit fish business in Egypt. Forty-one percent were facing water problems; this has to do with the agricultural drainage that they were using, and many of them were not comfortable but have no choice because it is the entitled water for aquaculture in the country. Twenty-five percent were faced with fish disease problems. This suggests urgent call for policy makers for intervention. Finance is the major problem facing aquaculture in Nigeria. Most of the respondents (54%) confirmed that finance is the major challenge unlike in Egypt where water is the major delinquent (Schematic 1).

## Conclusion and Recommendations

The research revealed that there were similarities and disparities in environmental changes indications in Egypt and Nigeria. Though the level of environmental changes awareness of the respondents in both countries varies, the fish farmers were aware of the environmental changes and its impacts on aquaculture. Aquaculture is an age-old practice in Egypt; however it is still contributing immensely to the country's GDP, employment, and food security as it is doing relatively in most

countries and is significant to the economic, livelihood, and nutritional welfare of the population. Conversely, Nigeria's aquaculture has the potential to contribute to both food security and economic development of the country, but it is still in a promising business. Efforts should be geared to address the critical issues such as climate change and other environmental factors that affect aquaculture practice in Nigeria. Continental and regional integration of aquaculture practices should be encouraged in Nigeria and other parts of Africa.

## References

- Adeleke ML (2013) Socioeconomic characteristics of the artisanal fisherfolks in the coastal region of Ondo State, Nigeria. *J Econ Sustain Dev* 4(2):2013133. [www.iiste.org](http://www.iiste.org). ISSN 2222-1700 (Paper) ISSN 2222-2855 (Online).
- Adeleke ML, Balogun AA (2013) Occurrence of climate change and its effects on the fishing activities in the coastal region of Ondo State, Nigeria. *Int J Dev Econ Sustain* 1(1):1–13
- Adeleke ML, Fagbenro OA (2013) Livelihood diversification and operational techniques of the artisanal fisherfolks in the coastal region of Ondo State, Nigeria. *Int J Innov Res Dev* 2(1):262–273
- Adeleke ML, Matthias W (2017) Chapter 13: Adaptation of the artisanal fisher folks to climate change in the coastal region of Ondo State, Nigeria. In: Leal Filho W (ed) *Innovation in climate change adaptation, climate change management*. Springer, Cham, pp 177–193. [https://doi.org/10.1007/978-3-319-25814-0\\_13](https://doi.org/10.1007/978-3-319-25814-0_13)
- FAO (2000) Fishery country profile, Nigeria. FID/CP/NIR Rev. 4. Food and Agriculture Organization of the United Nations, Rome
- FAO (2010) National Aquaculture Sector Overview. Egypt. National Aquaculture Sector Overview fact sheets. Text by Salem AM, Saleh MA In: FAO Fisheries and Aquaculture Department [online], Rome. Updated 16 Nov 2010 (cited 17 Apr 2015). [http://www.fao.org/fishery/countrysector/naso\\_egypt/en](http://www.fao.org/fishery/countrysector/naso_egypt/en)
- FAO (2012) The state of world fisheries and aquaculture 2012. FAO, Rome
- Food and Agricultural Organisation FAO (2016) The state of world fisheries and aquaculture 2016. Contributing to food security and nutrition for all. Rome. 200 pp
- French GT, Awosika LF, Ibe CE (1995) Sea level rise and Nigeria: potential impacts and consequences. *J Coast Res Spec Issue* 14:224–242
- GAINS Reports (2015) The state and development of aquaculture in Egypt. <https://gain.fas.usda.gov/.../The%20State%20and%20Development%20of%20Aquacu...> Nov 6, 2016
- Jhingran VG (1987) Lectures at ARAC for the Senior Aquaculturists course. Nigerian Institute for Oceanography and Marine Research Project RAF/82/009
- Maddison D (2007) The perception of and adaptation to climate change in Africa. Policy research working paper 4308. The World Bank, Development Research Group, Sustainable Rural and Urban Development Team, Washington, DC
- Nhemachena C, Mano R, Mudombi S, Muwanigwa V (2014) Perceptions on climate change and its impact on livelihoods in Hwange district, Zimbabwe. *Jamba J Disaster Risk Stud* 6(1):123. <https://doi.org/10.4102/jamba.v6i1.123>
- Olufayo MO (2012) The gender roles of women in aquaculture and food security in Nigeria. IIFET 2012 Tanzania Proceedings
- Sumaila UR, Christophe B, Alice T (2014) Fishing for the future: trends and issues in global fisheries trade. December 2014
- Worldometers (2017) Elaboration of data by United Nations, Department of Economic and Social Affairs, Population Division. World population prospects: 2017. [www.worldometers.info](http://www.worldometers.info)
- World Bank (2013) The Fish to 2030: Prospect for Fisheries and Aquaculture World Bank Report Number 83177-GLB (December 2013)

**Open Access** This chapter is licensed under the terms of the Creative Commons Attribution 4.0 International License (<http://creativecommons.org/licenses/by/4.0/>), which permits use, sharing, adaptation, distribution and reproduction in any medium or format, as long as you give appropriate credit to the original author(s) and the source, provide a link to the Creative Commons license and indicate if changes were made.

The images or other third party material in this chapter are included in the chapter's Creative Commons license, unless indicated otherwise in a credit line to the material. If material is not included in the chapter's Creative Commons license and your intended use is not permitted by statutory regulation or exceeds the permitted use, you will need to obtain permission directly from the copyright holder.



---

## **Part II**

# **Climate Change, Technologies, and Resources Management**



# Sustainable Urban Drainage Practices and Their Effects on Aquifer Recharge

# 43

Getrude Gichuhi and Stephen Gitahi

## Contents

Introduction .....	810
Related Works and Existing Gaps .....	812
Aquifers .....	814
Research Framework .....	815
Proposed Solutions .....	816
Substituting Alternative Water Source Control .....	817
Management of Aquifer Recharge .....	820
Management of Discharge of Water .....	824
Conclusions .....	825
References .....	826

## Abstract

Between 1994 and 2006, an 18% increase of freshwater flow into the earth's ocean was recorded, as well as extreme weather events such as prolonged drought and intense floods. Following this period was an era of increased evaporation from oceans and seas, which heightened global warming in Africa. This chapter proposes the use of man-made aquifers recharge processes as methods of draining water into the soil before the runoff water reaches water bodies. **Source control** involves controlling the volume of water entering drainage systems or rivers by cutting off runoff water through storing for reuse or evapotranspiration as seen in green roofs. **Pre-treatment** is the use of trenches to filter and remove

This chapter was previously published non-open access with exclusive rights reserved by the Publisher. It has been changed retrospectively to open access under a CC BY 4.0 license and the copyright holder is "The Author(s)". For further details, please see the license information at the end of the chapter.

G. Gichuhi (✉) · S. Gitahi

Department of Research and Innovation, Strathmore University, Nairobi, Kenya

e-mail: [ggichuhi@strathmore.edu](mailto:ggichuhi@strathmore.edu); [stephen.gitahi716@strathmore.edu](mailto:stephen.gitahi716@strathmore.edu)

© The Author(s) 2021

W. Leal Filho et al. (eds.), *African Handbook of Climate Change Adaptation*,  
[https://doi.org/10.1007/978-3-030-45106-6\\_67](https://doi.org/10.1007/978-3-030-45106-6_67)

809



contaminants from water before getting to water bodies. **Retention systems** on the other hand is controlling the rate at which water is discharged to waterways by providing water storage areas such as ponds, water retention areas, etc., while **Infiltration Systems** are areas that allow natural soaking of stormwater runoff to the ground naturally recharging the water table. The proposed methods will see replenishing of the water table, a great leap in the efforts of curbing global warming. This practice can easily be adopted by both individuals and government as we build more and more buildings creating a balance between the need for human settlement and the natural way of water replenishing itself. The methods do not introduce extra costs to an already existing budget. In some cases, the methods help to reduce the costs of projects especially in urban areas. Africa which hosts many of the growing countries sees and will continue to experience surges in urbanization. For such, these methods presented in this topic will be, if implemented, a best method to solve the urban drainage problems before this even occurs.

---

### Keywords

Aquifer · Hygiene and sanitation · Groundwater recharge · Global warming · Urban water balance · Universal water security · Topographical land

---

## Introduction

Since 1990, water rise in the sea and oceans has been recorded and is now more visible than any other time in human history (The Ocean Portal Team 2018). The highest attributed factor has been melting of glaciers on ice topped mountains and concrete constructions. This ice melts and flows as runoff water into small water collection points such as ponds and swamps to bigger water bodies such as rivers, lakes and oceans increasing water flow into water bodies. All these changes result in an increased global water cycle where water moves cycles through evaporation, precipitation, and runoff, an aftermath of increased rate of global warming.

Methods of mitigating the negative effects of climate change in Africa have become a big issue. Individual companies and governments in Africa are trying to implement resilient ways that adapt to the effects of climate change. African countries are prone to the effects of climate change especially because of the higher levels of industrialization. On the other hand, developed countries that have implemented ways of harnessing water and avoiding runoff water directly to catchment areas at all costs is something Africa has not been able to fully accomplish (The United Nations-Water 2015). According to a report by UNEP, by 2020, between 75 million to around 200 million people in the African continent are projected to experience water stress due to climate change (UN Environment Programme 2020). In this twenty-first century, most countries in Africa are becoming urbanized; modern housing, infrastructure, access to water, and implementation of technology has become common (Ogwu 2019). Narrowing down to East Africa, Kenya is the

most urbanized country and then followed by Rwanda. Cities are evolving and the idea of implementing sustainable urban drainage is still an issue as they improve the topography of cities.

Kenya's fastest growing cities include Nairobi, Mombasa, Thika, Machakos, Nakuru, Malindi, and Kisumu. Untapped but identified as potentially stable upcoming cities include, Tatu city and Konza city. This research identifies these two areas as the best place to promote sustainable urban drainage (SUD) systems and aquifer recharge is implemented. Other cities will follow the example set by these two as the benefits come to play. The total population for Kenya currently is at 54 million, according to the 2019 census; Nairobi, the capital city has just over four million people (Kenya Data Portal 2019). Water Security in a country is one of the major issues facing each country worldwide. According to Sustainable Water Partnership, water security is the adaptive capacity to safeguard the sustainable availability of, access to, and safe use of an adequate, reliable, and resilient quantity and quality of water for health, livelihoods, ecosystems, and productive economies (Viala 2016). UN Water defines water security as the ability of a community to protect their sustainable ways of accessing quality water (UN Water 2013). This is very vital especially to areas that have a huge population. Insufficient water in some areas is caused by drying up of the aquifers, while some areas are faced with excess water either due to flash floods, or rainwater runoff, which in turn leads to less aquifer recharge. These imbalances are a clear result of insufficient aquifer recharge. With no improved strategies to better ways of harnessing water, especially with the current climate projections showing irregular weather patterns, aridity of these cities is prone to increase at a very high rate. A case point is Two Rivers Phase II project, a modern residential center hosting a mall in Nairobi and Kiambu Counties in Kenya, which if the runoff water is not taken care of, the drying up of aquifers might kick off. Water in Two Rivers in which the development seats are likely to rise. Coastal areas are also facing similar issues. A case of concern there is salty water finding its way into the water table recharging the aquifers and thus making the water for consumption saline.

Rural-Urban transformation has improved the topography of most countries in Africa. Although, this has culminated in the improvement of settlement areas as well as the economic status of residents, it has heightened developmental challenges such as making water runoff move to a collection base settled in one area, which either flows to other big catchment areas or slowly evaporates. This chapter aims to put more emphasis on ensuring that sustainable urban drainage systems are implemented in a bid to see that boreholes that source water from aquifers are managed responsibly ensuring water availability and safety. Africa has not yet formulated the policy of adapting the best practices of sustainable urban drainage systems and natural aquifer recharge methods. Aridity of land, increase of saline water, drying up of aquifers, and increased water wastage, especially with increased upcoming constructions, are an indication of the state of globalization and effects of climate change in a country. Sustainable Urban Drainage Systems are drainage networks that act as collection points, transport, treat, retain, infiltrate and drain runoff water in sustainable ways that are beneficial for living things and the world in general (Hidrologia

Sostenible n.d.). Given this background, the aim of this chapter is to review the status of sustainable urban drainage and Aquifer recharge within African context, highlighting some technological advances to be used in the current scientific and topographical challenges of climate change.

---

## Related Works and Existing Gaps

This chapter uses referencing points, of developed countries, and how they implemented the SUDs, which affects the natural recharge of Aquifers. According to Matos (2003), drainage systems are not necessarily a rule when it comes to construction of infrastructures, and runoff water would cause flooding of the roads or clogging of the sewers. On the other hand, Tim (2008) speaks of the Christian era, where drainage systems constructed by the Romans in the BC to AD are still functioning till date. Introduction of sanitation began in Italy after an incident of septic tank sinking due to floods and the country was forced to eliminate flooding areas and adapt underground channels, which was a wake-up call to other European countries in adapting sanitation systems (Poletto and Tassi 2012).

The use of green gardens in developed countries that substitute farming due to construction of buildings covering the whole land makes it necessary to adapt previous ways of MAR. An important agenda highlighted in this chapter is to understand how policies are followed to the latter for avoidance of implementing after math eqs. A study conducted in the United Kingdom regarding their technical, legal, and planning methods of control for urban runoff water in their country was done to ensure countries that do not have policies created to govern engineers before starting projects (Woods et al. 2015). Governance of Aquifers needs to be implemented. There are three aspects done in developed countries as to the governance of aquifers, management of discharge of water, management of recharge, and substituting alternative water sources.

Management of discharge of water from the aquifers currently is important as drawings from these sources are at a high rate, especially due to the domestic use of the water. Some countries use water mainly for commercial use while others use water to pump for electricity, irrigation and domestic use as well. As depletion of aquifers becomes more and more real, countries are forced to dig deeper boreholes with extra costs to incur to reach water levels (Dillo et al. 2011). These scenarios put more weight on the need to ensure recharge of the aquifers is managed well. Management of Recharge to the aquifers can be implemented both artificially and naturally. If 95% of the land is covered with soil and grass then the possibility of water sipping into the soil is most likely to happen faster reducing the amount of water that flows into water bodies. With increased urbanization, more innovative methods of recharging of aquifers are practiced by directing water to catchment bodies, and using filtration methods that enable water to be soaked into the soil and thus refilling the aquifers. Other alternative ways of using water sources include using rainwater and customizing it for consumption use.

Due to urbanization, most countries experience a lot of runoff water, which therefore needs a number of managements of aquifer recharge procedures through identifying a number of solutions that gets back to the aquifers. These processes have been practiced before, and there is a need to introduce them in developing countries especially due to the increase of urbanization in these same countries. Use of permeable floors could be one of the implementing ways.

There are other substituting alternative water sources, which are currently used all over the world. Some authors have done research on how to tap water and collect it in a catchment where one can fetch for domestic use. Other water sources enhancements include channeling rain water through use of gutters, tapping water from a river into a house. More methods have been adapted in today's world to ensure that they have sources of water. Some negative points have been brought forward, such as some of these ways being harmful to the humans and the animals. A case study was carried out in Kilifi County in Kenya where the test was to find out the presence of arsenic in water and the pH of the same water. According to the World Health Organization (2003), pH of consumable water should be between 6.5 and 7.5.

A study research was done on SUDs in low-income countries in Africa outlining the disadvantages that runoff water instills such as soil erosion and siltation (Reed 2004). Some special cases have been raised, for instance, constructing riparian lands and coastal areas. These areas have a land mass that is not stable with fault lines that aid in the recharge of aquifers experience. Kenya has had cases of demolition of buildings due these buildings being on riparian lands, this was a threat not only to the SUDs not being observed but also to the lives of people who were meant to live and operate in such areas. Other concerns raised, is the groundwater overexploitation in the coastal regions and these buildings being on riparian lands. Groundwater over-exploitation in the coastal regions leads to intrusion of salty water (Geiger 2020). This chapter will help us understand the options that a country has in case it is forced to build on riparian lands.

Some practices recommended in this chapter exist in developed countries and can be very effective in African countries in understanding climate change and how to deal with the effects of those changes. There are challenges facing the Kenyan topography such as cases of constructions being done on riparian lands. Such areas are not stable and could result in the collapse of such buildings. It has resulted in the government demolishing such houses and prosecuting responsible constructors for not adhering to the rules and policies that guide the said industry. Coastal lands on the other hand have cases of saline water recharging the aquifers, making it difficult for consumption especially to humans. The best result in these situations is to ensure filtration methods are used.

Policy making for engineers and owners is one of the proposals for governments to implement. Adaptive measures of some proposed solutions are suggested in order to ensure smooth implementation of SUDs and aquifer recharge as well. These include filtration methods and systems of reducing salinity and the productive measures of constructing buildings in riparian lands. Resolving these issues with the proposed methods will see an increase in the amount of water that goes back to the water table, replenishing it, as opposed to flowing into the ocean and seas. On a

concrete surface, 95% of water on the surface runs off, only 5% gets absorbed into the soil. With natural aquifers taken into account in the landscape planning and designing, the 95% of the runoff water will be adsorbed to soil, resulting in only 5% of the water being drained to the oceans and seas. This mode of replenishing the water table ensures that wells and boreholes dug in arid and semi-arid areas do not dry up fast. The benefits of this extend to what such areas can do in their economic ventures and other activities made capable by the presence of stable water supply.

---

## Aquifers

When Water soaks into the soils from the rivers, melted ices, and rain, it is concentrated in one area that forms its own settlement, which is referred to as an aquifer. This settlement of water is formed in different bowl-like areas that form a well and are all in different areas with different levels. A number of aquifers formed in one area are referred to as the water table level forming the zone underneath the ground. There are two types of aquifers, the confined aquifers and the unconfined aquifers. Confined aquifers are one that is way below almost at the bedrock of the rocks and formed by permeable rocks due to the pressure of non-permeable rocks. However, getting to the confined areas at times seems difficult and collapsing of the rocks could hinder reaching the aquifers when drilling boreholes. Unconfined aquifers are the ones that are directly refilled with the water soaking directly from the surface of rivers or when in a swampy area or irrigation is taking place. The unconfined aquifers are the ones that rise or drops depending on the amount of water stored.

Aquifers in rural areas and with a water source around are less tapped as compared to an arid area. In semi-arid areas where these boreholes are drilled with the changing weather conditions and less water source reservoirs, humans turned to aquifers, through drilling boreholes in pursuit of water. Sometimes the water turns to be saline, depending on the locality. For instance, coastal areas tend to have more saline aquifers as compared to fertile moisture soil with cold weather conditions. As urbanization in coastal areas increases, the drilling of boreholes is increasingly at a higher rate. This in turn, due to unconfined aquifers being empty, is refilled with saline water from the ocean. This is reusable, however not as drinkable water for humans nor animals as well.

Consistent use of these aquifers without recharges is only sustainable for a few decades. According to Kansas States University in Manhattan, a 4-year research of the Ogallala Aquifer was conducted to identify the use of aquifers for irrigation and consumption use in Kansa, they found out that continued use with no recharge could cause depletion of food production in that area (Chow 2013). Glaciers melting sorted that situation for a while with the chances of aquifer usage to be in survival for 50 years, after it only used up to 30% of the water.

Glacier melts in areas whose topographical land is associated with mountains and areas that are cold and can experience snow. Africa, has very minimal of such topography and therefore, a few proposed solutions on ways to manage the discharge

of the water from the aquifers, how to recharge them and alternative ways of water use to avoid depletion of the groundwater.

## Research Framework

Looking at the sustainable urban drainage practices that are done to the developed countries and the effects of aquifer recharge, there is an understanding that SUDs consideration will be established in Africa. With a different topography, there is a need for an analysis of the geographical area to determine any potential trends that are made or can be made. The analysis done is to determine a number of things, the risk factors involved in case an SUD is proposed in that area, and the number of SUDs to be implemented in that area, and the demographics as well. After analysis, the topographic area will help in determining the type of qualitative criteria to be used for the SUDs.

Criteria	Relevance	Category
Guidance documents	These are the documents to be used as the implementation process for the SUDs in Africa. The use of these documents either required by the government or voluntarily offered to the government by the implementing partner shows the extent to which the SUDs would have effects on the aquifer recharge. These guidance documents can be used as practices that any organization or individual looking into SUDs should have, and also used as ways to overcome over implementation of SUDs in one area	Guidance documents not specified to SUDs but to construction – Policy constructions documents Standard government guidance for a country from the National Construction Authority Relevant government planning policy statements concerned with hydrology, and water as natural resource, e.g., a) delivering sustainable development policy b) Planning and pollution control policy c) Disaster and risk management policy – This looks deeper into drought and floods as ways of managing disasters and risks in a county
National Construction Authority Consultation	In order to ensure involvement, in the case of Kenya, it is important to ensure the National Construction Authority is involved for assessing the area, and the risk factors that could be involved	Consulting the National Construction Authority of a country, for location intelligence analysis, through the use of documents, records of previous assessments, reports, and telephone and email conversations.
Constrains	Financial constraints in case of a collapse of a borehole drilled or a pond created are some of the constraints involved when it comes to implementation of SUDs	Other constraints could be through desktop and site survey CLA not specified and not included in analysis due to no knowledge of contamination at site. 1 – CLA through desktop survey only. 2 – Desktop and site survey

(continued)

Criteria	Relevance	Category
SUDs type	This chapter categorizes SUDs into substituting alternative water sources control, Management of Aquifer recharge, and Management of Discharge of water	<b>Substituting alternative water sources control</b> (a) Green roofs (b) Rainwater harvest (c) Redirecting water retention systems <b>Management of Aquifer Recharge</b> (a) Infiltration systems (b) Treating municipal wastewater (c) Treating storm water (d) Treating irrigation water <b>Management of Discharge of water</b> (a) Retention systems (b) Wetlands
Numbers	Identifies current practice and baseline data	Types of SUDs to be used in that area
Size	Identifies current practice and baseline data	How large or small will the SUDs be used
Efficiency	Identifies current practice and baseline data	How sustainable is the SUD used
Maintenance	Identifies current practice, baseline data, potential barriers, ways to overcome them, and trends	How frequent should it be maintained and treated
Good practices	Africa as a developing continent, most of the topographical area is improving day by day, which makes runoff water become a potential problem especially to rural areas. Therefore, different mitigation process of water should be implemented in the policy making and as part of construction when it comes to buildings and roads	Use of best practices. Evidence of National Construction Environmental Management Plan or equivalent.

## Proposed Solutions

On the account that there is uncertainty when it comes to climate change and the shortage of water especially in Africa, adaptation strategies on water usage and refilling of aquifers should be prioritized. Clear projections on water demands in the future are merely determined by the climate change, sustainability imbalances between freshwater, and demand for it (Taylor et al. 2009). There is a huge difference of climate change association in developed countries as compared to the developing countries. In addition, the fact that most countries in Africa are in the sub-Saharan desert, the usage of water is more likely to be at a higher demand and also depletes at a higher rate.

Although, some of these solutions are implemented in other countries, recommending them to African countries, suits best especially during this time of globalization. African countries are known to be experiencing different kinds of weather conditions, as compared to developed countries. The Sub-Saharan desert covers most parts of Africa. Solutions proposed in this chapter targets what African countries would experience when it comes to recharge of aquifers as well as substitute water sources. Runoff water and the impact it has on climate change has the need of ensuring that the community is able to implement SUDs and redirect water to aquifers. This chapter discusses the methods to be used in African Countries in the management of discharge of water, management of recharge, and substituting alternative water sources.

### **Substituting Alternative Water Source Control**

It is clear that using water from Aquifers is not only the one area that humans should depend on if it is for consumption at home or commercial level. There are other means of attaining water with source control implemented. Source control is a way of managing the volume of water entering drainage systems or catchment areas by cutting off runoff water either to be redirected into another source stored for reuse or evapotranspiration or to absorb into the soil as a way of recharging the aquifer (Geiger 2020). Mostly runoff water will be from rainwater, flash floods, or melting of glaciers. Besides, source control can be exercised when the water is settled in one area with no use of it. Wet areas are an example of how source control can be used.

A country's topography has around four features that affect how humans will cultivate and settle around that area (National parks Association n.d.). These are the landforms, which include the hills, valleys, gullies, and mountains, etc. These places act as animals settling places but as a tourist attraction to humans, which affects the economic status of a country. A water source is another feature of land topography, which mostly includes the rivers, swamps, coastal oceans, etc., which have a great impact on affecting our sources of water. Vegetation includes the national parks, the farmlands, etc., acting as the main source of food to both humans and animals. Manmade topographic features, which fall under the category that most humans ensure that they plough and invest in, comprises of buildings, roads, property boundaries etc.

The four features of land topography have a huge effect on aquifer recharge; the recharging of the aquifers depends on how much is interrupted. For instance, if the sources of water, rivers, swamps, oceans are polluted, the same water used to recharge the aquifers will reach the table water polluted which becomes harmful to human beings and animal consumption. On the other hand, if manmade features of the topography are not structured in a way that allows runoff water to seep back to the ground the possibility of the aquifer to recharge is of bare minimal. The untapped areas such as landforms and vegetation are most likely to have the water table to be fully recharged or at least for use through soil moisture and suitable for plantations.



## Green Roofs

The level of a city becoming smart has better ways of ensuring that it implements source control mechanisms. Green roofs are a way of turning barren landscapes into a living network of gardens (Willem 2005). It is a type of urban agriculture and a way of saving space and at the same time living expenses are reduced. Green roofs have a number of advantages such as:

- (a) Reduction of runoff water – one of the main aspects that African Countries are trying to fight
- (b) Act as a temperature buffer for the home. The plants combat the natural heat and coolness from the atmosphere
- (c) Economical potential of cultivating food from the green roofs

Green roofs comprise a multilayered system that covers the roof of a building with vegetable landscaping. The roof is likely to consist of an impermeable layer, a growing medium, and a drainage layer. The impermeable layer aids in the survival of the plants by increasing the retention time of water in the substrate layer thus increasing the soil moisture. The Substrate layer or the growing medium layer retains the water and uses the right amount of organic and mineral proportions. The drainage system is the most important part in setting up the Green Garden. There are different types of drainage systems; however, the ideal one is that which provides good circulation and evacuation while at the same time offering water supply to the crops. In today's modern green garden drainage system, they use rigid and open mesh structures plastic sheets (Critical Concrete 2018).

Although, not to say that green roofs should be used in places where aquifer recharge is a priority, it only states that it can be used as an alternative source of acquiring water for consumption use and irrigation use as well. The implementation of Green roofs especially in urban areas of a country ensures hydrologic-hydraulic invariances in that area. This is one of the main areas that this chapter tries to focus.

## Rainwater Harvest

Rainwater harvesting refers to different methods used to channel rainwater into an area where it can be used for other purposes (Black et al. 2012). There are various types of rain water harvesting systems used in different countries, which depends on the cost, size, and the complexity of the technology involved. However, the main aim is to ensure utilization of rainfall to be used as an alternative source of water both domestically and commercially. The beauty of it is that it can be used in a small or large industry or even at the homestead level. With the current climate changes, using resources to ensure the survival and usage of clean water in the future has been one of the ways to fight drought.

The collection of rainwater from rooftops, or other surfaces or even open space into a catchment area is known as rainwater harvesting. This harvested rainwater could be used commercially, domestically, or for farming purposes (irrigation). On the other hand, harvesting rainwater could act as an advantage by providing stormwater management especially in urban areas thus leading to detention pools,

which are used to recharge aquifers. Slow runoff water has a higher chance of soaking into the ground, which has other advantages such as reducing contamination and avoidance of soil saturation.

The types of rainwater harvesting include:

1. Domestic rainwater harvesting. There are two types of harvesting systems used especially in developed countries: gravity systems and pump feed systems. Gravity systems are positioned at the top of a building, which uses gravity to propel water to different parts of the house. Examples are the use of gutters to direct water to the tanks. Pump feed systems on the other hand, is when water is pumped upward toward different water holding objects or tanks to be used for domestic use. Drilling of boreholes is an example of pump feed systems.
2. Commercial rainwater harvesting. There are different types of harvesting systems that are used in large farms. The most common one is water butts, which is one of the common harvesting systems used in the UK. Water butts are barrel-like or bin-like tanks that collect water from drain pipes to store water that could be reused for farm use (The Renewable Energy Hub UK 2018).

Although, at times the collected water may not be user friendly, the level of treatment when it comes to harvested rainwater depends on the use required and the dimensions of the size of a home or industry. Water required for Aquifer Recharge will definitely undergo a strict way of treatment as compared to one used for irrigation purposes. Also, water required for human consumption will require strict treatment unlike farm use or irrigation; some TDS would be left in the water in order to give nutrients to the plants.

### **Redirecting Water in Retention Systems**

Urbanization in today's world is more of covering all land with cement, leaving only the rural with soil. This significantly increases the runoff water to drainage systems, which are redirected to the rivers or other water catchments. In Rural areas the rate at which water soaks back to the soil and absorbed back to the soil is at around 95% as compared to an urban area, in which the water soaks only 5% that at least lands on soil, leaving only 95% running off. Urbanization in a retro sense has its effects on affecting water that flows. However, there are precautions that engineers can take when constructing buildings and roads.

In cases of riparian lands, as stated earlier in the two rivers case, policies and design ideas ought to be structured to ensure that water is not blocked. Water flowing rates, its magnitude, frequency, and duration should be part of the measures that are included when constructing in riparian lands. In addition, these features can determine at what rate and amount it will soak into the ground and down to the aquifers. Therefore, channelling the water and either use it is another means of source of water for commercial use or constructing measurable ways of ensuring that there is no runoff water. For swampy areas, at times the ground is too full to absorb more water and will result in flooding of homes, in this case there should be a channel that redirects where this water needs to be absorbed back to the ground in a land that is a bit semi-arid.

Riparian land has been managed before using three practical methods, the Proper Functioning Condition (PFC), the Hydrogeomorphic Approach (HGM), and the index of Biological Integrity (IBI). In spite of the advancements in technology, African Countries have not yet implemented such strategies. PFC is a qualitative approach and depends on the knowledge and judgment of a team of experts. HGM and IBI on the other hand are based on quantitative data gathered and analyzed from unaltered to degraded sites prior to assessor's involvement (National Research Council 2002).

## **Management of Aquifer Recharge**

### **Infiltration Systems**

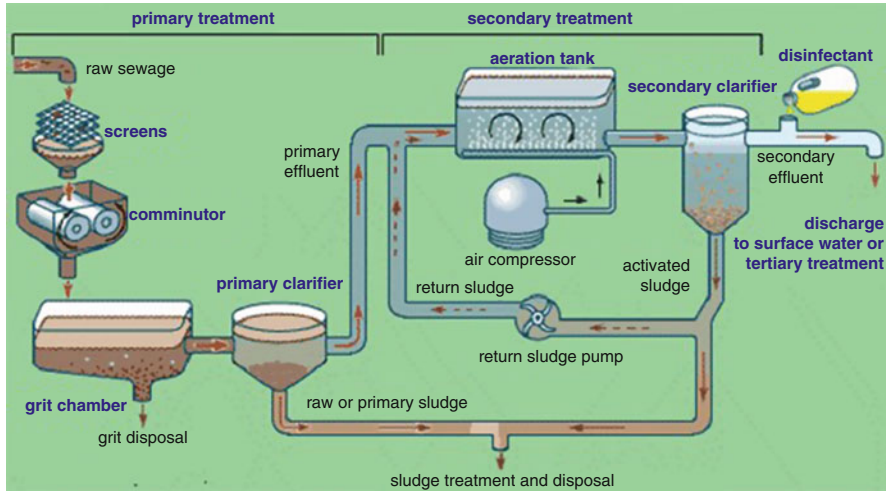
In the intent of refilling deep aquifers, a process involved, happens at a gradual rate through the unsaturated zone all the way to the aquifers. Although, there are underlying factors that depend whether the aquifer is suited in an area where it was used repeatedly then refilling it might take ages to do so. The creation of infiltration systems will look into a number of risk assessments, which include, land cover, soil characteristics, soil saturation, slope of the land, and evapotranspiration (Alley et al. 1999).

Dependency on water and the rate at which the water is used while it depletes in the aquifers depends on the population of a country; it is not only used by humans but also animals. Controlled ways of recharging the aquifers need to be implemented in order to ensure safety for the consumption of water. There are two ways of recharge, artificial recharge and Natural recharge. Artificial recharge is the process by which excess surface water is directed into the ground either by spreading on the surface, using recharge wells or altering natural conditions to increase infiltration. It is a way of storing water in case of a shortage.

There are a number of ways recharged water can be used. It can be redirected to semi-arid areas and arid areas for consumption and irrigation schemes. In coastal areas, with the use of artificial recharge, since it is fresh, this could be used as a control mechanism in avoiding seawater or saline water intrusion to the aquifers. There are three types of infiltration systems for aquifer recharge as a source of water, Treated Municipal Wastewater, Storm-water runoff, and irrigation water. In order to implement infiltration systems, risk assessments should be conducted by the government to ensure safety measures are in order. Infiltration systems largely influence ground stability and water quality as the latter flows to water streams. Examples of such systems are infiltration trenches, basins, and permeable paving.

### **Treating Municipal Wastewater**

For the Municipal water of a country ensures that it treats and input infiltration systems there are a number of things they would consider. The quantity and quality of wastewater in an area, the commercial and industrial establishment off an area, and the condition of the sewer system. The municipality has to analyze the wastewater at their disposal and then run the ingredients they are to concentrate and



**Fig. 1** Figure of the treatment process of Municipal Wastewater Infiltration process. (Eschool 2018).

dissolve. Untreated wastewater contains an amount of microorganisms' concentration. These factors include originality of the water used, the general health of the contribution population (are they in a slum area or in an urban area), and the infectious agents that survived outside the hosts under a variety of environmental conditions (The viruses, in a group become resistant to the environment that kills bacteria). Wastewater treatments are classified in primary, secondary and advanced level (Fig. 1).

The wastewater is first pumped to the system, and as a primary treatment, it is screened, then taken through to the grit chamber where the solid and huge particles are released, and finally to the secondary stage through the clarifier. The secondary treatment stage incorporates aeration process, which after takes the advanced treatment stage, which is the final stage before the water is directed to the aquifers for refilling or tanks for industrial or household use.

#### a) Primary treatment of municipal wastewater

This is the first step that includes screening of the state of the wastewater and grit removal. Once the water is screened, large solid particles are removed to avoid any interference at a late stage of treatment. Grit chambers are created as part of the infiltration systems to remove sand, seeds, glasses, eggshells, etc. There are other preliminary treatment operations such as the flocculation, odor control, chemical treatment, and pre-aeration. Primary treatment has very little effect when it comes to the removal of other biological species, which means it does not remove viruses at this stage

#### b) Secondary treatment of Municipal wastewater

This step is intended to remove soluble and colloidal biodegradable organic matter and other suspended solids (SS). This treatment involves an aerobic

biological process whereby microorganisms oxidize organic matter in the wastewater.

**c) Advanced treatment of Municipal wastewater**

This is the third stage of removal of nutrients, for instance, phosphorus and nitrogen and SS. This is the physical, chemical, or biological treatment process used to accomplish a degree of treatment. It removes SS and dissolved substances either organic or inorganic in nature. This is necessary especially if there is a direct injection into the aquifers for recharge. The major processes in this stage include, coagulation-sedimentation, filtration, nitrification, denitrification, phosphorus removal, carbon adsorption, and reverse osmosis.

**Stormwater Runoff**

Stormwater runoff is one of the main contributors when it comes to aquifer recharge. However, pollution of the stormwater may contaminate the aquifers as well once they reach them, which needs treatment before they reach the aquifers. It is erratic in quantity and the timing as well could be when flash floods happen, or when a heavy rain has occurred. According to Larry, he tends to believe that season has a major impact when it comes to storm-water runoff quantity and the base flow (Mays 2001). The topography of an area has a major impact when it comes to stormwater pollution concentration, which tends to filter the pollutants. Impervious surfaces on driveways, parking areas, gutter drainage systems, and roads reduce infiltration of runoff and runoff to the ground.

Detention ponds are constructed for specifically recharging groundwater through the bottom of the pond. The water filters slowly through the ponds and to the aquifer, they are created deep enough to prevent water plant growth but shallow enough to prevent anaerobic conditions formed at the bottom. Inspection is necessary occasionally to ensure that treated water is what recharges the aquifers.

As a concept of salt evaporation ponds, water is directed into a pond where it is stored while it slowly soaks into the ground to the aquifers. In Kenya, Kitui District, Sand dams were created in order to store water, although this was only done in large-scale farms. A sand dam is constructed as a small dam, in and onto a riverbed of a seasonal river, where it is accumulated with sand. The sand layer acts as a filter for removing contamination and enabling water to reach the aquifers and recharge them. With areas that frequently receive huge rainfalls, there are chances of groundwater levels being high considering the use of multiple sand dams.

Subsurface dams is another way of ensuring an aquifer recharge is exercised. They are created in semi-arid areas at the seasonal riverbanks, by digging a trench to the bedrock or other impervious layer. This is something that is exercised in Brazil and can be implemented in Kenya especially in semi-arid counties, such as Kilifi county. To prevent particles soaking into the ground, use of canvas when creating the trench is necessary to act as filters, which could puncture the fabric used.

**Treating Storm-Water**

Hydrogeologists ensure that they calculate the right places for constructions on ponds and measure input when it comes to treating the water to be used to refill

**Fig. 2** Figure of Filtration process for stormwater runoff (Fluence News Team 2017).



the aquifers, as well as calculating the right places that have aquifers that have enough water to be used. Sedimentation is the process of allowing suspended particles in water to settle out of the suspension under the effect of gravity. These particles become sludge, which is assisted by mechanical means that cause it to thicken (Bache and Gregory 2007).

Although removal of particles can vary from one version to the other, the variations of storm-water filtration may include vegetation filtration, drainage systems, and impervious pavements. The settlement of particles in ponds varies in different ponds in different areas. Therefore, when it comes to filtration either natural cause of treatment could occur when it comes to biodegradation, biotransformation, and bioaccumulation or the sedimentation process (Fig. 2).

### **Irrigation Water**

Irrigation is considered one of the most important roles in food production in pursuit of food security of a country. Although exploitation of aquifer water for irrigation, and consumption use, particularly during dry season, has caused the groundwater level to decline in semi-arid and arid areas, there is no direct recharge of shallow aquifers. With the increasing use of groundwater, the rise of hydrogeological and climate change problems are becoming major setbacks of certain countries. However, Irrigation Return Flow (IRF) is a promising way of recharging the aquifers for better sustainability in the future.

Irrigation return flow is the excess drainage water collected from irrigated farmland, which is considered as not evapotranspiration or evacuated by surface water and is returned to the aquifer (Dewandel et al. 2008). Depending on the types of crops, there are likely to be a number of agricultural chemicals applied, with a varying range of quantity input to enable growth and avoid pests. Irrigation is mostly used in semi-arid and arid areas; this increases the salinity of the IRF to three times that of normal water.

### **Treatment**

Numerous things are involved in the irrigation return flow water that includes TDS, nitrogen and phosphorous compounds, pesticides residues, and, at times, metallic substances. There are different kinds of technologies that have been implemented in

different countries, especially with advanced technology, to ensure removal of such pollutants.

Reverse osmosis system is one of the technologies used; it is a process that uses a permeable membrane to remove TDS. The first step of reverse osmosis is the sediment filter. It is a polypropylene sediment pre-filter that removes SS from the water. Then the carbon granule filter is activated, which removes the chlorine and other organic substances, unpleasant color, tastes, and odors from the sediment water. The third stage is to activate the carbon block filter, which removes the remaining chlorine and organic substance without the carbon fines. The RO Membrane is the fourth stage that rejects the wide spectrum of impurities including bacteria and viruses. Finally, the polishing resin carbon filter dissolves gases to ensure freshness and natural tasting clean water (Hydrolink Technologies 2014).

Farm-led management is another implementation that most developed countries are undertaking. This involves training farmers on crop selection in relation to soils, methods of increasing yields, community-based pond water monitoring, and evaluation and knowledge management on aquifers. Besides that, training the farmers on the consequences of excessive use and implementation of well-directed aquifer protection measures has helped farmers to understand the quantity of water usage, fertilizers, and wastes to use.

## **Management of Discharge of Water**

When water moves out of the saturated area or ground to the surface through springs or seeps, it is referred to as groundwater discharge. However, at times, groundwater discharge can be controlled, where water is pumped to a retaining tank or catchment basin. To ensure that water is used at a manageable rate, to avoid depletion of groundwater, control has to be instilled to ensure that this happens. There are various ways to ensure this happens, through creation of retention systems, existence of wetlands, and others.

### **Retention Systems**

These are water systems meant to control the rate at which water is discharged to waterways by providing water storage areas such as ponds and small-scale basins. Retention systems are systems used to store water that is likely to be used for a longer period unlike detention systems that only store water for a short period and thereafter redirect filtered water back to the ground to refill the aquifers.

A case in point is, as the rainfall season approaches, seasonal rivers tend to overflow and at times cause flood in certain areas especially ones that are arid. In this case, building of retention systems to pump water from the river to the systems could help in the use of the water during dry seasons.

### **Wetlands**

Another way that discharge of groundwater happens is through the existence of wetland areas. The riparian lands as well as the swampy areas are in balance due to

the discharge of the groundwater. Though wetlands also come with various benefits of ensuring that the soil is hydric and at the same time maintaining the ecosystems habitant in these areas, the increase of groundwater discharge to springs and streams dampens the amplitude of flow fluctuations thus sustaining associated wetland environments. As a control mechanism, artificial wetlands are best ways to mitigate stormwater runoff issues.

---

## Conclusions

This chapter recommends the smart infrastructure management methods and mitigation of rainwater and runoff through practices that direct water to catchment areas with a purpose of meeting the needs of saving water and utilization of water especially for African Countries. The focus on African countries is due to some falling under dry regions which means the possibilities of these countries being faced with reduction of water in the 50 years from now would be high in case they do not observe the different methods of mitigating water. Besides, the use of these mitigation processes has socioeconomic impacts, which include the reduction of negative impacts of disaster risk management such as floods and drought on social life and reduction of energy costs, which is economical to a country.

Most countries in Africa are currently adapting the advanced technologies such as Internet of Things (IoT), and Artificial Intelligence, either, in their cities, homes, or work environments. Implementation of MAR with such technologies has a likelihood of ensuring quality, and sufficient water for most African countries, thus improving the country's economic status. The main agenda is to ensure that we avoid urban flooding in African Countries, with the implementation of infrastructures that help in redirecting runoff water to refill aquifers when already treated. This chapter suggested a number of solutions such as permeable pavements, implementation of green roofs, retention systems, rainwater harvesting methods, and use of catchment areas.

Policy-making guidelines is another way to direct constructors on how to implement certain measures when constructing a structure that could distract water flow to reach the aquifers when treated and safe. Use of these guidelines ensures to incorporate the decision making and avoid constraints such as environmental constraints (instability) and financial constraints (more expenses in water treatments and retention systems).

Water harvesting and other techniques have been used to help preserve water before runoff, the use of man-made aquifer recharge methods as a form of SUDs is a natural and more efficient way of helping runoff water to seep back to the water table and ensure a balance. This allows the table to follow its natural way of seeping in between permeable rocks from saturated to unsaturated areas. While trying to curb global warming, this is a step toward managing the effects of the melting ice caps through the natural replenishing of the water table. This practice can easily be adopted by everyone as we build more and more buildings creating a balance between the need for human settlement and the natural way of water replenishing itself.



## References

- Alley W, Reilly TE, Franke OL (1999) Sustainability of ground-water resources. CIR. U.S. Dept of the Interior. U.S Geological Survey. <https://doi.org/10.3133/cir1186>
- Bache DH, Gregory R (2007) Flocs in water treatment. The International Water Association Publishing
- Black J, Maimbo M, Oduor A, Cherogony K, Meerman K (2012) Rainwater harvesting inventory of Kenya. An overview of techniques, sustainability factor and stakeholders. <https://doi.org/10.13140/2.1.2299.5208>
- Chow D (2013) Water woes: vast US aquifer is being tapped out. *Live Science*. Retrieved from <https://www.livescience.com/39186-kansas-aquifer-water-depletion.html>
- Critical Concrete (2018, December 18) Retrieved from critical concrete website: <https://criticalconcrete.com/green-roof/>
- Dewandel B, Ganolfi JM, De Condappa D, Ahmad S (2008) An efficient methodology for estimating irrigation return flow coefficients of irrigated crops at watershed and seasonal scale. *Web of Science Core Collection* 22(11):1700–1712. <https://doi.org/10.1002/hyp.6738>
- Dillo P, Enrique F, Albert T (2011) Management of aquifer recharge and discharge processes and aquifer storage Equilibrium. Thematic Paper
- Eschool (2018) Wastewater treatment types. Retrieved from <https://eschool.iaspaper.net/wastewater-treatment-facts/wastewater-treatment-types/>
- Fluence News Team (2017, May 8) Fluence. Retrieved from Fluence: <https://www.fluencecorp.com/what-is-stormwater/>
- Geiger WF (2020) Sustainable water management chance for mega cities in developing countries. In: International symposium on new directions in urban water management
- Hidrologia Sostenible (n.d.) Hidrologia sostenible. Retrieved from Hidrologia Sostenible: <http://hidrologiasostenible.com/sustainable-urban-drainage-systems-suds/>
- Hydrolink Technologies (2014) Hydrolink technologies. Retrieved from Hydrolink Technologies: <http://hydrolink.co.ke/reverse-osmosis-systems>
- Kenya Data Portal (2019) Kenya data portal. Retrieved from Kenya Data Portal: <https://kenya.opendataforafrica.org/>
- Matos JS (2003) Aspectos Históricos a Actuais da Evolução da Drenagem de Águas Residuais em Meio Urbano. *Revista Engenharia Civil*, Lisboa
- Mays LW (2001) Stormwater collection systems design handbook. McGraw Hill Professional, New York
- National parks Association (n.d.) National parks association of NSW. Retrieved from National Parks Association: <http://www.bushwalking101.org/recognising-topographic-features/>
- National Research Council (2002) Riparian areas: functions and strategies for management. Consensus Study Report. <https://doi.org/10.17226/10327>
- Ogwu M (2019) Towards sustainable development in Africa: the challenge of urbanization and climate change adaptation. (P. a. Cobbinah, Ed.) *The geography of climate change adaptation in Urban Africa*. pp. 29–55. Retrieved from [https://doi.org/10.1007/978-3-030-04873-0\\_2](https://doi.org/10.1007/978-3-030-04873-0_2)
- Poleto C, Tassi R (2012) Sustainable urban drainage systems. Federal University of Technology, Brazil
- Reed B (2004) Sustainable urban Drainage in Low-income Countries. Water, Engineering and Development Centre. Loughborough University Leicestershire. Loughborough University, UK
- Taylor RG, Koussis AD, Tindimugaya C (2009) Groundwater and climate in Africa. *Hydrological Science Journal* 655–664. <https://doi.org/10.1623/hysj.54.4.655>
- The Ocean Portal Team (2018) Ocean portal. Retrieved from Ocean Portal: <https://ocean.si.edu/through-time/ancient-seas/sea-level-rise>
- The Renewable Energy Hub UK (2018) The renewable energy hub UK. Retrieved from The Renewable Energy Hub UK Website: <https://www.renewableenergyhub.co.uk/main/rainwater-harvesting-information/types-of-rainwater-harvesting/>
- The United Nations-Water (2015) Water for a sustainable world. United Nations Educational, Scientific and Cultural, de Fontenoy

- Tim II (2008) Trabalho de Integralização Multidisciplinar II. Termo de Referência
- UN Environment Programme (2020) UN environment programme. Retrieved from UN Environment Programme: <https://www.unenvironment.org/regions/africa/regional-initiatives/responding-climate-change>
- UN Water (2013) UN - water. Retrieved from UN - Water: <https://www.unwater.org/publications/water-security-infographic/>
- Viala E (2016) USAID. Retrieved from USAID
- Willem VC (2005) Rooftop gardening
- Woods BB, Wilson S, Udale-Clarke H, Illiman S, Scott T, Ashley R, Kellagher (2015) The SUDS manual. Construction Industry Research and Information Association, London
- World Health Organization (2003) pH in drinking-water. Guidelines for drinking-water quality, 2. Marketing and Dissemination, World Health Organization. Geneva 27, Switzerland

**Open Access** This chapter is licensed under the terms of the Creative Commons Attribution 4.0 International License (<http://creativecommons.org/licenses/by/4.0/>), which permits use, sharing, adaptation, distribution and reproduction in any medium or format, as long as you give appropriate credit to the original author(s) and the source, provide a link to the Creative Commons license and indicate if changes were made.

The images or other third party material in this chapter are included in the chapter's Creative Commons license, unless indicated otherwise in a credit line to the material. If material is not included in the chapter's Creative Commons license and your intended use is not permitted by statutory regulation or exceeds the permitted use, you will need to obtain permission directly from the copyright holder.





# Building Livelihoods Resilience in the Face of Climate Change: Case Study of Small-Holder Farmers in Tanzania

# 44

Saumu Ibrahim Mwashu and Zoe Robinson

## Contents

Introduction .....	830
Background .....	830
Description of the Study Areas and Methodology .....	831
Study Area .....	831
Research Methods .....	831
Results and Discussion .....	835
Maximizing Existing Household Assets: Household Decision-Making and Female Empowerment .....	836
Building the Household Assets Base .....	837
Managing Natural and Physical Capital: Managing Slow Variables .....	839
Livelihood Diversification .....	843
The Role of Government in Building Small-Holder Farmer Resilience and Adaptation to Climate Change .....	843
Conclusion .....	844
References .....	845

## Abstract

The impacts of climate change are already being felt on human and environmental systems, with the brunt of the impacts being felt by communities in the Global South, particularly small-holder farmers due to their poverty levels and greater direct dependency on natural resources for their livelihoods. Hence, there is a need to understand how to build small-holder farmers' resilience to climate change. Climate change adaptation strategies need to build livelihood resilience

This chapter was previously published non-open access with exclusive rights reserved by the Publisher. It has been changed retrospectively to open access under a CC BY 4.0 license and the copyright holder is "The Author(s)". For further details, please see the license information at the end of the chapter.

S. I. Mwashu (✉) · Z. Robinson

School of Geography, Geology and the Environment, Keele University, Staffordshire, UK

© The Author(s) 2021

W. Leal Filho et al. (eds.), *African Handbook of Climate Change Adaptation*,  
[https://doi.org/10.1007/978-3-030-45106-6\\_49](https://doi.org/10.1007/978-3-030-45106-6_49)

829

in the face of climate change as well as address the factors that contribute to farmers' vulnerability. This chapter draws from a mixed-method study conducted in three villages each in a different agro-ecological zone in the Kilimanjaro region, Tanzania, to explore how to build farmers' livelihood resilience through addressing factors that increase livelihood vulnerability to climate change. These farmers' livelihoods are vulnerable because of both the impacts of climate variability on the farmers' livelihood assets and certain social and environmental structures and characteristics. Building small-holder farmers' livelihood resilience that can ensure the desired levels of livelihood outcomes in the face of climate variability and change, requires integration of strategies across household resource management as well as farm-based livelihood assets, and a holistic rather than piecemeal approach to small-holder farmers' livelihoods.

---

**Keywords**

Climate change · Adaptation · Small-holder farmer · Livelihoods · Resilience

---

## Introduction

### Background

The impacts of climate change are expected to affect human and environmental systems across the globe but the more devastating impacts are projected to occur in developing countries particularly affecting small-holder farmers (Serdeczny et al. 2017). Many small-holder farmers especially in Sub-Saharan Africa farm and live in an extremely challenging environment. The production environment is characterized by reliance on rain-fed agriculture, a low level of economic diversification, and low livelihood productivity (Output per unit of input (Yu et al. 2002)) (Di Falco and Veronesi 2013). Climate change is expected to intensify existing challenges and thus there is an urgent need for adaptation of the livelihoods of small-holder farmers to enable them to thrive in the face of climate change.

Addressing how to build resilient small-holder farmers' livelihoods through adaptation to climate change is vital for food security as well as livelihood development (Afifi et al. 2014). To address these issues, considerable emphasis is placed by researchers on describing specific locally relevant agricultural or natural resource management practices or innovations that could potentially deal with impacts of extreme events at the farm/household level. However, it is important to note that the application of these strategies is context-specific and that several constraints exist that may limit farmers' capacity to optimize their benefits. Therefore, there is a need to develop adaptation tailored to the need of that community (Ebi and Burton 2008). The context-specific adaptations result from examining the vulnerability of the target community empirically, and utilizing community experience and knowledge to examine exposure and sensitivity of the community to climate change (Ebi and Burton 2008). The context-specific adaptation strategies or practices based on

examination of adaptation needs of the specific community will generate more practical measures (Ebi and Burton 2008). Adaptation based on this approach is less developed (Paavola 2008), and this research helps fill this gap by presenting potential adaptation strategies that small-holder farmers in the Kilimanjaro region of Tanzania can use to adapt to increasing climate variability. Further information about the exposure and sensitivity of these small-holder farmer communities can be found in Mwasha (2020).

---

## Description of the Study Areas and Methodology

### Study Area

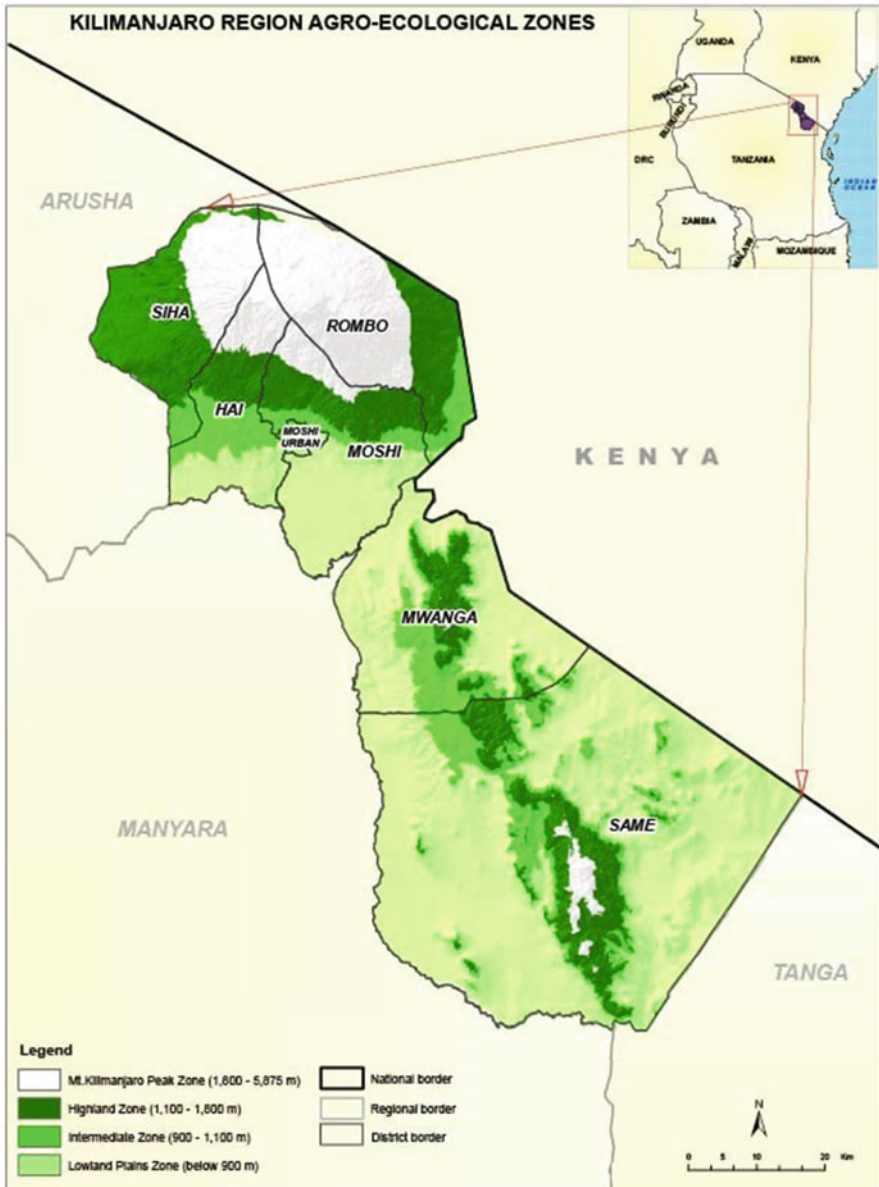
The study was conducted in the Kilimanjaro region located in the North-eastern part of the Tanzania mainland. The region is divided into four agro-ecological zones; the forest reserve and Kilimanjaro mountain peak where no farming activities take place, and the highland, midland, and lowland zones where farmers are located (Fig. 1). Although all zones receive rainfall twice a year, the amount in each zone differs. Characteristics of the different zones are shown in Table 1.

### Research Methods

#### Underpinning Theoretical Frameworks

Two lenses of analysis were used in this research; a livelihood approach drawing on the sustainable livelihood framework of the UK Department for International Development (DFID) (1999) and socio-ecological resilience drawing primarily on the work of Biggs et al. (2012, 2015). The sustainable livelihood framework is an analytical structure to facilitate understanding of broad factors that constrain or enhance livelihood opportunities, and puts people and their access to assets (financial, human, social, natural, and physical) at the center of this understanding (Reed et al. 2013). This framework also considers livelihood diversification as a risk management strategy and the role of institutions' structures and processes in shaping peoples' livelihoods (Ellis 2000). One of the main proponents of the use of a sustainable livelihood framework to studies of climate change resilience of poor communities is Tanner et al. (2015). They argued for resilience studies to incorporate a livelihood approach in order to pay attention to fundamental issues of human agency and empowerment, putting people at the center by focusing on capacities for human (rather than environmental) transformation.

Biggs et al. (2012, 2015) distinguish between resilience as a property of social-ecological systems (SES) and resilience as an approach and set of assumptions for analyzing, understanding, and managing change in SES. As a system property, they define resilience of SES as the capacity of an SES to sustain human well-being in the face of change, both through buffering shocks and also through adapting or transforming in response to change (Biggs et al. 2015). In order to analyze or build the



**Fig. 1** Location of the Kilimanjaro region and different agro-ecological zones. (Source: Author 2020)

resilience of a system, Biggs et al. (2012, 2015) identify seven principles. The first principle refers to diversity and redundancy. Diversity involves the provision of different options for responding to change, achieved by ensuring variety (the number of different elements), balance (the number of representatives of each element), and

**Table 1** Key characteristics of the three agro-ecological zones included in this study (information from Soini 2005; O'Brien et al. 2008; Regional socioeconomic profile, 2014)

Zone	Altitude (m above sea level)	Soil fertility	Rainfall (mm/a)	Temperature range (°C)	Population density (people/km <sup>2</sup> )	Major crops	Livestock and additional comments
Highland	1100–1800	High	1250–2000	15–20	650	Wheat, beans, barley, coffee, banana, fruits, round potatoes	Majority of livestock are stall-fed. Some families own or rent plots of land in other zones particularly in the lowland zone.
Midland	900–1100	Moderate	800–1250		250	Coffee, banana, maize, beans	Dairy cattle, goats, pigs, rabbits, poultry farming
Lowland	<900		700–900	Average annual >30	50	Maize, cotton, rice, sorghum, cassava, pigeon peas	Beef cattle, goats, pigs, sheep. Provides fodder during the dry season for animals in all zones. Livestock mostly freely grazed because of the availability of open spaces especially after crops have been harvested

disparity (how different the elements are from one another). Redundancy describes the replication of elements within a system. The second principle is to manage connectivity, focusing on the way in which parts of an SES interact with each other. The third principle is to manage feedbacks and slow variables, such as long-term changes to environmental assets such as soil fertility. The fourth principle is to foster complex adaptive system thinking. The fifth principle is to encourage learning and experimentation. The sixth principle is to broaden participation and the seventh to promote polycentric governance systems. This chapter draws primarily on principles one to three, further analysis of the principles in the context of this study can be seen in Mwasha (2020).

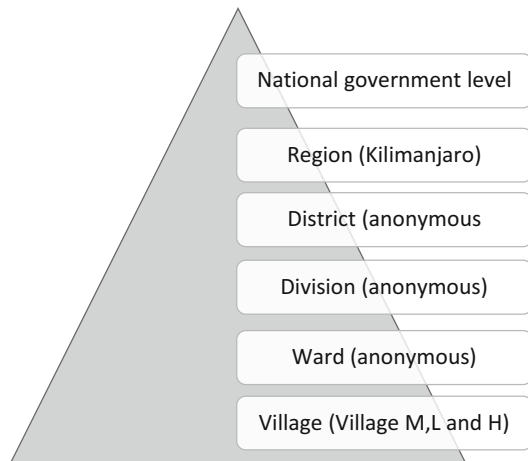
### Study Site Selection and Sampling Methods

The administrative structure in which the villages included in this study site is shown in Fig. 2. The district in which the study was conducted was selected in discussion with the regional environmental officer (who oversees activities related to the environment in the region) based on preset criteria: accessibility, evidence of climate change, and the presence of the three agro-ecological zones. The Kilimanjaro region has seven districts, but only some have three agro-ecological zones. Simple random sampling was used to select one ward from each agro-ecological zone in the selected district, and to pick one village in each ward. The district, ward, and villages are not named in order to maintain anonymity.

### Data Sources, Collection Methods, and Analysis

Data were gathered from individual household surveys of household heads (who were all small-holder farmers) in the study villages, focus group discussions in each village, interviews with key informants, and researcher observations. Although the survey did not ask about the total household size because I wanted to understand the labor force, the regional socioeconomic profile (2014) shows that the Kilimanjaro

**Fig. 2** Administrative structure in Tanzania





region had an average household size of 4.3 in 2012 which is the lowest in the country compared to a national average household size of 4.8 in the same year. The household surveys collected quantitative and qualitative data on the household heads' perceptions of the impact of climate change on the livelihood assets and farm production practices utilized by the household. The total numbers of interviewed households were 47, 35, and 24 in the highland, midland, and lowland zones, respectively. The total numbers of village for highland, midland, and lowland were 946, 702, and 483, respectively. Except in the lowland zone where the focus group was mixed gender, the midland and highland focus groups were gender-based. The focus group discussions explored trends in crop production, soil fertility, animal keeping, water availability, and management practices and their implication to climate change adaptation, as well as information about social factors that contribute to small-holder farmers' vulnerability to climate change. Interviews were held with five key informants (a community development officer; a representative from the Tanzania Coffee Research Institute; a district and village agriculture extension officer; and a network of farmers' groups in *Tanzania which is Nongovernmental Organization*) to understand their roles in helping farmers successfully adapt to climate change, factors that hinder farmers' adaptation ability, and potential solutions. Observations in the villages by the researcher were used to inform understanding of existing farm production practices. The data were collected in the Swahili language and translation was carried out by the researcher alongside data transcription. Details of the socioeconomic characteristics of the villages and measures contributing to livelihood vulnerability are found in Mwashia (2020) thesis.

The household survey data arises from closed-ended questions and open-ended questions with brief answers. The analysis of closed question data was carried out using SPSS descriptive statistics and qualitative data were manually coded using in vivo coding and descriptive coding, and grouped under the themes identified and entered into SPSS for analysis.

Data from the key informant interviews and focus groups were manually analyzed (Basit 2003). The transcription text was analyzed using evaluative coding based on the research questions (Smith and Firth 2011). The codes developed were categorized into different topics and then linked to form themes (Saldana 2009; Smith and Firth 2011).

---

## Results and Discussion

This section is structured around four key areas of focus to support small-holder farmer adaptation to increase resilience to climate change. The first section focuses on the role of maximizing existing household assets, focusing specifically on human and social capital. The second section focuses on the management of physical and natural capital, also referred to as managing slow variables in reference to one of Biggs et al.'s (2015) resilience principles. The third section looks at the role of livelihood diversification, a key component of the sustainable livelihoods framework (DFID 1999), in building livelihood resilience to climate change, and Biggs et al.'s (2012, 2015) principles for

building resilience. The fourth section explores the role of government in supporting small-holder farmers' adaptation and resilience to climate change.

### **Maximizing Existing Household Assets: Household Decision-Making and Female Empowerment**

The way in which a household's assets in terms of income and produce are utilized have a major role in building livelihood resilience. Both male and female focus group participants in the highland and midland zones gave examples of how division in household responsibilities (i.e., responsibility for keeping the family fed, sheltered, educated, clothed) and divided ownership of resources within households (i.e., certain cash crops typically belonging to male members of the household) could lead to resources being used without consideration of what is best for the whole household. Focus group participants in the highland and midland zones viewed it as preferable to have joint ownership of assets and shared household responsibilities, where what is produced in the household is considered to belong to the whole family; with couples planning together how those resources are used, creating more transparent and balanced decision-making in the household. In the lowland focus group discussion, division of ownership, and household obligation were said to have no impact on household resilience. However, as the lowland focus group was mixed gender, participants may not have been willing to discuss the issues arising from different gender roles within the household. The details of division of household obligations of gender roles are found in Mwashu (2020).

Achieving more balanced decision-making around resource use within households is supported by wider policies that promote the empowerment of women through increasing access to education and financial capital. The need to support female empowerment was supported in discussions within both gender focus groups in the highland and midland zones as there was no direct question asked about this matter but it came up during the discussion about household resource use and its impact on household resilience to climate variability and change. The empowerment of women is also reported in the literature as increasing household resilience to climate change (Almario-Desoloc 2014). However, not all women in the Kilimanjaro region, and Tanzania in general, have access to these opportunities (Kato and Kratzer 2013), and the slow pace of change requires other strategies to be adopted in some households to address problems of household resource utilization stemming from household inequities. In the highland and midland, there was discussion of how some women would hide some crop produce to be able to use this in times of adversity; showing how individual household strategies are used in helping build household resilience.

Another strategy farmers in all focus groups reported to use to build resilience relates to food storage systems especially after harvest to give food a longer life and protect it from damage. The focus group participants in all three zones mentioned the use of storage tanks which are tightly sealed after being filled with food, especially maize and beans (other crops were also mentioned by female

participants), as their main method of storing food, to provide reserve food stocks in times of limited harvests. Although there was no specific question asked about food storage systems, these discussions came about while exploring hunger periods in the study area.

## **Building the Household Assets Base**

Small-holder farmer livelihoods depend on the quality of the assets (human, social, financial, and natural capitals) to which a household has access. The available assets form the foundation upon which livelihoods are built and define the ability of the people in question to execute different livelihoods strategies (Chambers and Conway 1992; DFID 1999; Ellis 2000; Scoones 2009). The discussion below explores ways to further build human and social capital (assets) which were perceived by respondents to be decreasing in the study area, and through this build resilience to climate change.

### **Building Human Capital**

Human capital can be defined as the available labor force within a household to contribute to agricultural production, income generation, and household management. The household surveys identified that human capital was negatively affected as a result of malaria which has intensified by increasing temperatures allowing the geographic spread of mosquitoes particularly into the highland zone.

Adaptation strategies are needed to deal with an increase in malaria and its impact on human capital (Onwujekwe et al. 2000; Teklehaimanot and Mejia 2008; Asenso-Okyere et al. 2011). Teklehaimanot and Mejia (2008) summarized malaria control strategies as follows:

- Provision of early diagnosis and prompt treatment
- Selective and sustainable use of preventive measures, including vector control
- Prevention, early detection, and containment of epidemics
- Strengthening local abilities and applied research

These strategies require actions at both government and household level. Households are responsible for using preventive measures such as mosquito bed nets, managing the environment to reduce mosquito habitats, and going to the hospital when they get ill for diagnosis and treatment. The government is responsible for educating people about control measures, ensuring access to control measures and medical services, and investing in research on prevention and treatment of malaria diseases. Poverty also plays a crucial role in explaining why certain population groups are more vulnerable to malaria, because of the inability to pay for insecticide-treated bed nets and access to medical health (Teklehaimanot and Mejia 2008). In the study area, the household survey showed that most families were provided with free mosquito nets by the government to prevent malaria disease.

### Building Social Capital

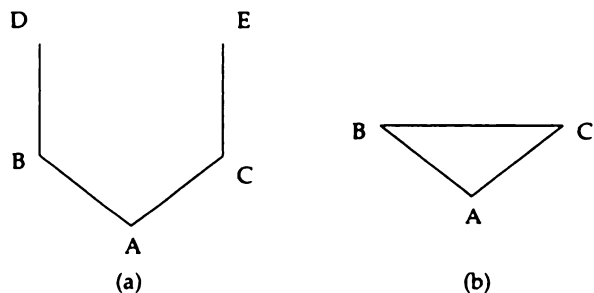
The household surveys in this study show a perceived decrease in social capital (described as support that households provide to each other) partly caused by climate variability reducing the amount of crop yield. Social capital is important as it can help households survive the impacts of poverty (Baiyegunhi 2014) through providing security in times of distress and access to resources (Grech 2012). There are different ways that households or individuals can build social capital. Baron et al. (2000) identified two different aspects of social relations that can build social capital for households and individuals: (i) obligations, expectations, and trustworthiness; and (ii) norms and effective sanctions.

One core element of social capital is where people are willing to help each other and do things for each other, relating to Baron et al.'s (2000) "obligations, expectations, and trust." For example, if an individual (named A) does something for B, and trusts B to reciprocate in the future, this establishes expectations in A and an obligation on the part of B. As A does the same to more people, and these people are trustworthy and responsible, this creates good safety nets for A in the event that something happens to A. This study revealed one practice based on these concepts of social capital, in the saving of food resources by one household for another, to be taken back in times of need. This area of social capital was the preserve of females in the communities who reported to support each other in this way.

Social capital can also be developed through the development of norms and sanctions (Baron et al. 2000). However, these can be fragile as some people can misuse them for personal interest. Norms and sanctions relevant to this study include the promotion of norms that encourage family members and neighbors to act selflessly in support of others, which may be reciprocated, providing positive motivations. For example, a household which does not support another household may not be supported if they need help themselves (negative motivation), while the household which supports another during difficult times may be positively motivated by the possibility of needing support themselves in the future.

These aspects that develop social capital for households and individuals are strengthened by social structures with high interconnectedness and interdependency between all actors (Fig. 3; Baron et al. 2000). This can be seen as another form of social capital; the connectivity of social structures that allow the proliferation of obligations and expectations. For example, in a less connected "open structure"

**Fig. 3** Social networks without closure (a) and with closure within the social networks (b). (Source: Baron et al. 2000)



(Fig. 3a) individual A can carry out actions that negatively affect D and E who are not acquainted with each other, and therefore cannot unite to control the negative effects from A. In contrast, Fig. 3b shows that all actors are connected and therefore there will be stronger motivation for A to avoid negative effects on other actors.

The household survey and information from the community development officer shows that in the study area some households have developed structures that facilitate social capital. They support each other by forming groups based on similarities between members such as family relations, friends, or similar work space or type. The groups work as informal saving and credit institutions, and members get different services such as access to loans and social support in case they face shocks in their life. Based on information from key informants, there is some nongovernment organization capacity building of these groups by providing training into how groups select leaders and develop financial management and group policy. The government encourages group members to register through the community development office to increase accountability but most are reluctant to register because of registration fees. More government-subsidized training and waiving of registration fees could improve social capital in the area.

Drawing on the insights from Baron et al. (2000), households and individuals can improve their social capital by their own acts to support others and by developing trusted networks of individuals and households within their community, increasing their sources of support for times of adversity. Village-level initiatives based around these principles could also help develop social capital through promoting norms, trust, and responsibility and interconnectedness at the community level. Government-level initiatives can also help support more formalized social support networks such as credit unions.

## **Managing Natural and Physical Capital: Managing Slow Variables**

This subsection adopts the concept of managing “slow variables” as used in Biggs et al.’s (2012; 2015) resilience framework. Slow variables are those variables that change slowly and can take time for changes in them to be noticed. The slow variables considered in this study focus on soil and water, two key areas of natural capital on which small-holder farmers depend, and which the results show have been affected negatively by management practices. Drawing on the study’s focus group discussions, household surveys, key informant interviews, and wider literature, this section describes strategies to ensure the adequate supply of water for agriculture, and strategies to improve soil fertility in the face of declines in these “slow variable” assets.

### **Managing Water Resources**

Poor decisions and practices made by farmers, such as crop choice and inadequate water source management practices, can affect agricultural productivity particularly under weather-related stress (Bot and Benites 2005). This section looks at how farmers will need to adapt to climate change by choosing appropriate crops to

grow by considering plant traits with tolerance of water stress, conservation of water sources, and employing farming practices that encourage water infiltration and conserve soil moisture.

### **Planting Crops That Can Survive Climate Variability**

Data collected in the study area demonstrated that in all three zones the types of agricultural produce grown by farmers threatens the capacity of the existing water resources to sustain agricultural production in the area, particularly as available water resources are perceived to have decreased. Cultivation of high value, high water demand crops, particularly horticultural produce such as tomatoes, cucumbers, onions, and carrots, has increased, increasing pressure on water resources. Although there are benefits to practicing horticulture as produce can be harvested in a relatively short time, the viability of these choices of crop is in question because of the capacity to sustain production in the long-term with trends of declining water availability. In contrast, traditional maize varieties are perceived to take a long time to mature (~6 months) which makes them vulnerable to the more variable rainfall patterns, potentially preventing the crops from reaching maturity. One solution is to replace traditional maize seeds with early maturing maize varieties which can survive the increased rainfall variability. In addition, planting drought-resistant crops such as millet is another strategy for managing the effects of decreasing rainfall amount and increasing variability. However, the results from this study show that the use of these crops is low in all three zones. As some farmers have negative attitudes toward crops like millet and cassava (another drought-resistant crop), there is the need for the government to encourage farmers to grow these crops through the development of an effective market for these crops. Government can also play a role in supporting further research into alternative drought-resistant crops but with a need to ensure that these will meet the needs and wants of small-holder farmers.

### **Conservation of Water Sources**

Across all three zones, there are a number of different practices that were discussed as being important for the conservation of water resources, including encouraging on-farm tree planting and avoiding the cutting down of trees. The relationship between trees and water resources is complicated (Ellison et al. 2017). However, there is some indication that increasing tree planting on farms can help preserve water resources through the effect of shading to reduce evaporative loss from soils (Clement et al. 2016).

The use of farming techniques for increasing infiltration, reducing surface runoff and evaporation, and improving soil water availability is essential in dealing with weather-related shocks (Biazin et al. 2012). There was evidence of these practices in the study area. For example, in the highland zone the use of terraces was reported to help control soil erosion, as well as reducing surface runoff and increasing infiltration (Biazin et al. 2012). In the lowland zone, farmers reported using minimal tillage in order to protect soil moisture.

### **Rainwater Harvesting**

Rainwater harvesting may also increase productivity from existing rainfall. The harvesting systems mentioned by focus group participants can be categorized into two types: earth dams and spate irrigation. Focus group participants in all three zones reported the need for earth dams especially in the lowland zone, to harvest available rainwater and use it for supplemental irrigation.

The use of spate irrigation was mentioned in the focus group in the lowland zone, where floodwaters from the highlands are channeled to nearby fields through gravity or water pumps to irrigate farms in the lowlands. This approach is used to cope with dry spells by taking advantage of the rain happening in upland areas even though it has ceased in lowland areas, as the rainy seasons last longer in the highland and midland zones relative to the lowland zone.

In addition to providing additional water sources, farmers with access to spate irrigation reported other benefits such as improved soil fertility, reducing the use of fertilizer on their farms because the spate water comes with eroded materials that are nutrient-rich. Although this strategy has many benefits it may come with other challenges because large flash floods can potentially cause damage to crops and prepared land (Komakech et al. 2012), although this was not mentioned by any focus group or household survey participant.

In addition to direct interventions such as water-conservation farming practices, wider systemic issues leading to poverty need to be addressed, because in some cases it is these systemic issues that push farmers in this area to inappropriately use water sources as a survival strategy. For example, as a result of reliable crop market, farmers chop down trees to sell timber as alternative source of income.

### **Managing Soil Fertility**

Management of soil fertility particularly where weather-related shocks are experienced is vital for reducing the impact of climate change on soils as well as improving water productivity (Biazin et al. 2012). Soil fertility-related land management practices include appropriate use of fertilizer and soil conservation methods to reduce erosion and maintain organic matter (Clair and Lynch 2010; Kaczan et al. 2013). Farmers in the study area identified strategies to increase soil fertility and conserve soil moisture such as mulching by retaining crop residues in fields, intercropping, the use of organic fertilizers, minimal tillage, and agroforestry as potential adaptation strategies. However, comparison between zones shows that while retaining crop residues, intercropping and use of organic fertilizers were mentioned in all three zones, minimal tillage was not discussed as a strategy in the midland and highland zones. In addition, the role of agroforestry was debated in the lowland zone, with the majority of participants believing agroforestry to be appropriate in the midland and highland zones but not in the lowland zone because they perceive the crops grown in the lowland zone (see Table 1) do not require the shade provided by trees.

Focus group participants believed that given the increased nature of climate variability and projected climate change, the benefits from retaining crop residues in fields were more important than ever. However, although maintaining crop

residues in fields was seen as an important potential adaptation measure to build livelihood resilience to climate variability, it was also acknowledged that this is hindered by the free grazing of animals by livestock keepers residing in the lowland zone. This was particularly problematic for farmers in the highland zone who also held farmland in the lowland zone, and were not able to monitor their land in the lowland zone. In addition, the need for fodder for livestock kept in the midland and highland zones was partly met by the transport of crop residues from the lowland zone. Participants reported that the nature of the issues faced meant that farmers now needed to find the balance between livestock feed and improving agricultural soils through retaining crops residue.

In dealing with competing crop residue demands, agricultural intensification can help increase the amount of biomass produced which can be divided between livestock and that which can be retained in the soils. In addition, free-grazing animals in the lowland zone should be discouraged to motivate farmers to retain part of the residues in the farms. Livestock keepers should be encouraged to sell some of their livestock and retain only that which they can maintain using their own resources.

Agroforestry was also mentioned as a potential adaptation strategy to address issues of declining soil fertility in the study area in all focus group discussions. The household survey results showed that participants believed this strategy to have both socioeconomic and environmental benefits. Research literature has also reported several benefits of agroforestry, including an increase in soil organic matter, erosion control, reduced sensitivity to harsh weather, natural pest and disease control, and provision of an alternative source of income (Reyes et al. 2005; Nair 2007; Nguyen et al. 2013; Pumariño et al. 2015; Sepúlveda and Carrillo 2015; Schwab et al. 2015). It is important to acknowledge that, in the survey results, there were a small number of respondents who disagreed about the benefits of agroforestry (particularly in the lowland zone) when combined with cereal crops like maize. However, studies do suggest that there is potential for agroforestry within maize production (e.g., Garrity et al. 2010), which offers opportunity to explore further types of trees that could be relevant in the study area to be integrated with maize, but the acceptance of farmers would need to be developed.

The use of organic fertilizer from livestock is another potential strategy to enhance agricultural productivity (Clair and Lynch 2010) and was reported by focus group participants and key informants. However, farmers reported that the main challenge of using organic fertilizer was the inconvenience for some associated with transferring manure from the homestead where cattle are kept to the farm fields which could be up to 5 km from households. There are several potential ways to address these issues, including farmers cooperating with neighboring farm owners to hire transport and share the transportation costs. This shows the importance of social capital (in terms of a strong supportive community willing to work collectively) to address a range of issues. However, it should be acknowledged that any additional costs may be prohibitive for the poorest farmers highlighting that mechanisms to address financial capital and systemic issues leading to poverty underpin many different solutions.



## Livelihood Diversification

Small-holder farmers in the study area have access to three different areas of livelihood contribution: (i) crop production for subsistence, (ii) livestock keeping for subsistence, and (iii) off-farm income activities, including small business such as small shops, street vending, and sale of agricultural products for income. The results from this study show that not all households diversify their livelihoods even though in the focus group discussions in all three agro-ecological zones it was reported that households should ensure they have more than one livelihood option as a risk management strategy, particularly important in the face of increased climate change variability. Given the types of livelihood options practiced in the study area, there are some similar dependencies in almost all livelihood options. For example, crop production and livestock keeping are all dependent on natural capital such as soil fertility and water resource availability. This suggests that if the flow and stock of these resources are affected by climate change or climate variability, the main livelihood contributions will be affected even where there is some diversity in income. Drawing on Biggs et al.'s (2012, 2015) resilience principles, it is clear that greater resilience can be achieved with greater disparity in the diversification options, and therefore having different livelihood options based around agriculture may provide less resilience than including diversification away from agriculture.

## The Role of Government in Building Small-Holder Farmer Resilience and Adaptation to Climate Change

This subsection looks at the role of government in helping farmers to adapt to climate change in the Kilimanjaro region of Tanzania. The discussion is divided into two areas: (i) the role of government officials (e.g., agriculture extension officers and community development officers); (ii) government policies and directives. Nongovernmental Organizations also often play an important role in tackling livelihood adaptations in the Global South (e.g., Kajimbwa 2006; Oshewolo 2011). However, the role of NGOs was not a focus of this study and only one NGO was included as a key informant interview, nor were NGOs brought up by study participants in the discussions of livelihood resilience and adaptation to climate change. Government officials provide small-holder farmers with access to different services. For example, connections between farmers and agriculture extension services are an important way of providing farmers with timely and relevant knowledge on agricultural aspects of livelihood management (Fosu-Mensah et al. 2012) especially where traditional knowledge systems do not work in responding to climate change (Shackleton et al. 2015). The need to improve access to agriculture extension officers was mentioned by some respondents in the household survey as well as in key informant interviews. Access to extension officers by small-holder farmers could be improved by allocating more extension service providers to farmers as well as providing the service providers with improved means of transport to facilitate their transport to the small-holder farmer villages. The community

development officers differ to agriculture extension officers in that they work with farmers to provide financial capital. However, the existing financial support given to women and youth group projects was reported to be inadequate compared to the demand. Therefore, the government needs to provide other sources of support such as credit, which farmers can exploit as access to financial capital is essential to facilitate adaptation (Deressa et al. 2011; Ndamani and Watanabe 2015; Belay et al. 2017).

There are a number of policy areas that were identified in the study where government could make adjustments to create more favorable conditions to support farmers' adaptation to climate change. These include: the 2007 Warehouse Receipt System (WRS) introduced to help farmers take advantage of price fluctuations by enabling farmers to store crops in warehouses and sell them when prices are high (MAFAP 2013). There was low use of WRS, especially for cereal crops. The government needs to increase the capacity of cooperatives unions, farmers' organizations, and savings and credit cooperatives to be able to implement the WRS for the variety of crops that are produced in the study area.

There are several areas of regulations where there is weak implementation causing availability of fake agricultural inputs in the market. Examples include, the Seeds Act (2003) which regulates the production and trade of all varieties of agricultural seeds including the mandatory provision of seeds for quality assurance; the Fertilizer Act (2009) regulates and controls the quality of fertilizer, either domestically produced or imported; and the Tropical Pesticides Research Institute Act (1979) which regulates research on pesticides for the purpose of ensuring their quality. The study participants reported poor implementation of these regulations with negative effects on the farmers. This shows a need for the government to ensure existing laws and policies are implemented more effectively to achieve the intended results. There were also government actions which small-holder farmers directly referred to as having a negative effect on their livelihoods. These included an export ban on crops preventing farmers from maximizing income in times of food scarcity in other countries (but supporting food security within Tanzania); government appropriation of resources (particularly water) for urban areas; and the lack of implementation of a requirement for using scales for measurement of agricultural produce meaning that farmers often ended up being short-changed by unscrupulous buyers.

---

## Conclusion

This chapter discusses areas of focus to build the livelihood resilience to climate change of small-holder farmers in the Kilimanjaro region of Tanzania, drawing on results from a study of three villages in the region and key informant interviews. Building small-holder farmers' livelihood resilience needs to be tackled at different spatial and temporal scales; from individual farmer decisions to government interventions, from short-term to long-term strategies, and in different spheres from household management practices, agricultural practices, livelihood diversification,

to the building of community and social capital, and the development of wider regulatory and economic systems.

These results highlight the importance of scale and context. Even a single region, such as the Kilimanjaro region studied here, is not a homogenous block. Although there were some similarities across the three agro-ecological zones such as the importance of measures to build social capital, control malaria disease, and the overall management of slow variables, there were some distinctions in the actual practices for management of slow variables as well as the existing social structures affecting resilience within the household. For example, the use of terraces and agroforestry was perceived as relevant in the highland and midland zones while leaving crop residues, minimal tillage, and drought-resistant crops were articulated more in the lowland zone. However, it should also be remembered that these zones do not exist in isolation, for example, some small-holder farmers own land in a different zone to the one in which they live, water resources from the highland zone travel through the midland and lowland zone, and forage for livestock may be sourced from a different zone. Therefore, changes implemented in one zone also have the potential to impact other zones, requiring adaptation measures to both respond to the specific context of an area and understand the interconnections between areas.

Combining a socioecological resilience framework and sustainable livelihood framework provides an important approach to understand small-holder farmers' assets bases as well as their vulnerability and sensitivity to climate change (Mwasha 2020). This combined framework also helps to understand the barriers to climate change adaptation strategies as well as strategies to build resilience to climate change across different temporal and spatial scales and spheres. Building resilience principles into sustainable livelihoods thinking clearly has a role to play in addressing the resilience to climate change of small-holder farmer livelihoods in the study region and likely throughout the Global South.

---

## References

- Affi T, Liwenga E, Kwezi L (2014) Rainfall-induced crop failure, food insecurity and out-migration in same-Kilimanjaro, Tanzania. *Clim Dev* 6(1):53–60. <https://doi.org/10.1080/17565529.2013.826128>
- Almario-Desoloc MS (2014) Women empowerment and climate change adaptation in northern Quezon. *Asia Pac J Multidiscip Res* 2(4):14–21
- Asenso-Okyere K, Asante FA, Tarekegn J, Andam KS (2011) A review of the economic impact of malaria in agricultural development. *Agricultural economics* 42(3):293–304
- Baiyegunhi LJS (2014) Social capital effects on rural household poverty in Msinga, KwaZulu-Natal, South Africa. *Agrekon*. Taylor & Francis 53(2):47–64
- Baron S, Field J, Schuller T (2000) *Social capital: critical perspectives*. Oxford University Press, Oxford
- Basit T (2003) Manual or electronic? The role of coding in qualitative data analysis. *Educ Res*. Taylor & Francis 45(2):143–154
- Belay A et al. (2017) Smallholder farmers adaptation to climate change and determinants of their adaptation decisions in the Central Rift Valley of Ethiopia. *Agriculture and Food Security*. *BioMed Central* 6(1):1–13. <https://doi.org/10.1186/s40066-017-0100-1>

- Biazin B, et al. (2012) Rainwater harvesting and management in rainfed agricultural systems in sub-Saharan Africa – a review. *Phys Chem Earth*. Elsevier Ltd, 47–48:139–151. <https://doi.org/10.1016/j.pce.2011.08.015>
- Biggs R et al (2012) Toward principles for enhancing the resilience of ecosystem services. *Annu Rev Environ Resour* 37:421–448
- Biggs R, Schlüter M, Schoon ML (2015) Principles for building resilience: sustaining ecosystem services in social-ecological systems. Cambridge University Press, Cambridge, MA
- Bot A, Benites J (2005) The importance of soil organic matter: key to drought-resistant soil and sustained food production. Food & Agriculture Organization of the United Nations, Rome
- Chambers R, Conway G (1992) Sustainable rural livelihoods: practical concepts for the 21st century. Institute of Development Studies (UK)
- Clair SBS, Lynch JP (2010) The opening of Pandora's Box: climate change impacts on soil fertility and crop nutrition in developing countries. *Plant and Soil* 335(1–2):101–115
- Clement M, Mwakilila S, Norbert J (2016) Implications of land use and climate change on water balance components in the Sigi Catchment, Tanzania. *J Geograph Assoc Tanzania* 39(1)
- Deressa TT, Hassan RM, Ringler C (2011) Perception of and adaptation to climate change by farmers in the Nile basin of Ethiopia. *J Agric Sci*. Cambridge University Press 149(1):23–31
- DFID UK (1999) Sustainable livelihoods guidance sheets. London: DFID, 445
- Di Falco S, Veronesi M (2013) How can African agriculture adapt to climate change? A counterfactual analysis from Ethiopia. *Land Econ* 89(4):743–766. <https://doi.org/10.3368/le.89.4.743>
- Ebi KL, Burton I (2008) Identifying practical adaptation options: an approach to address climate change-related health risks. *Environ Sci Policy*. Elsevier 11(4):359–369
- Ellis F (2000) Rural livelihoods and diversity in developing countries. Oxford university press, Oxford
- Ellison D, et al. (2017) Trees, forests and water: cool insights for a hot world. *Glob Environ Change*. Elsevier 43:51–61
- Fosu-Mensah BY, Vlek PLG, MacCarthy DS (2012) 'Farmers' perception and adaptation to climate change: a case study of Sekyedumase district in Ghana. *Environ Dev Sustain*. Springer 14(4):495–505
- Garrity DP, et al. (2010) Evergreen agriculture: a robust approach to sustainable food security in Africa. *Food Secur*. Springer 2(3):197–214
- Grech S (2012) Disability, communities of poverty and the global south: debating through social capital. In: *Inclusive communities*. Brill Sense, Boston, pp 69–84
- Kaczan D, Arslan A, Lipper L (2013) Climate-smart agriculture: A review of current practice of agroforestry and conservation agriculture in Malawi and Zambia. Rome: United Nations Food and Agriculture Organization
- Kajimbwa M (2006) NGOs and their role in the global south. *Int J Not-for-Profit L* 9:58
- Kato MP, Kratzer J (2013) Empowering women through microfinance: evidence from Tanzania. *ACRN J Entrepreneurship Perspect* 2(1):31–59
- Komakech HC, Van der Zaag P, Van Koppen B (2012) The Last Will Be First: Water Transfers from Agriculture to Cities in the Pangani River Basin, Tanzania. *Water Alternatives* 5(3)
- MAFAP (2013) Review of food and agricultural policies in the United Republic of Tanzania. MAFAP Country Report Series, FAO, Rome, Italy
- Mwashu SI (2020) Livelihoods, vulnerability, and adaptation to climate change of small-holder farmers in Kilimanjaro, Tanzania. Unpublished PhD thesis, University of Keele, UK
- Nair PR (2007) The coming of age of agroforestry. *Journal of the Science of Food and Agriculture* 87(9):1613–1619

- Ndaman F, Watanabe T (2015) Farmers' perceptions about adaptation practices to climate change and barriers to adaptation: A micro-level study in Ghana. *Water* 7(9):4593–4604
- Nguyen Q, Hoang MH, Öborn I, van Noordwijk M (2013) Multipurpose agroforestry as a climate change resiliency option for farmers: an example of local adaptation in Vietnam. *Climatic change* 117(1–2):241–257
- O'Brien G, et al. (2008) Climate adaptation from a poverty perspective. *Clim Policy*. Taylor & Francis 8(2):194–201
- Onwujekwe O, Chima R, Okonkwo P (2000) Economic burden of malaria illness on households versus that of all other illness episodes: a study in five malaria holoendemic Nigerian communities. *Health policy* 54(2):143–159
- Oshewolo S (2011) Limited policy engagement of non-governmental organizations: a guilt trip on the Nigerian state. *J Sustain Dev Africa* 13(1):142–152
- Paavola J (2008) Livelihoods, vulnerability and adaptation to climate change in Morogoro, Tanzania. *Environ Sci Policy*. Elsevier 11(7):642–654
- Pumariño L, Sileshi GW, Gripenberg S, Kaartinen R, Barrios E, Muchane MN, Midega C, Jonsson M (2015) Effects of agroforestry on pest, disease and weed control: a meta-analysis. *Basic and Applied Ecology* 16(7):573–582
- Reed MS, et al. (2013) Combining analytical frameworks to assess livelihood vulnerability to climate change and analyse adaptation options. *Ecol Econ*. Elsevier 94:66–77
- Reyes T, Quiroz R, Msikula S (2005) Socio-economic comparison between traditional and improved cultivation methods in agroforestry systems, East Usambara Mountains, Tanzania. *Environ Manag*. Springer, 36(5):682–690
- Saldana J (2009) Chapter 1: An introduction to codes and coding. In J Saldaña (Ed.) *The coding manual for qualitative researchers* (pp. 3–21). Thousand Oaks, CA: Sage
- Schwab N, Schickhoff U, Fischer E (2015) Transition to agroforestry significantly improves soil quality: A case study in the central mid-hills of Nepal. *Agriculture Ecosystems & Environment* 205:57–69
- Scoones I (2009) Livelihoods perspectives and rural development. *J Peasant Stud*. Taylor & Francis 36(1):171–196
- Sepúlveda RB, Carrillo AA (2015) Soil erosion and erosion thresholds in an agroforestry system of coffee (*Coffea arabica*) and mixed shade trees (*Inga* spp and *Musa* spp) in Northern Nicaragua. *Agriculture Ecosystems & Environment* 210:25–35
- Serdeczny O et al. (2017) Climate change impacts in Sub-Saharan Africa: from physical changes to their social repercussions. *Regional Environmental Change* 17(6):1585–1600. <https://doi.org/10.1007/s10113-015-0910-2>.
- Shackleton S, et al. (2015) Why is socially-just climate change adaptation in sub-Saharan Africa so challenging? A review of barriers identified from empirical cases. *Wiley Interdiscip Rev Clim Chang*. Wiley Online Library, 6(3), pp. 321–344
- Smith J, Firth J (2011) *Qualitative data analysis: the framework approach*. Nurse researcher. RCN Publishing Company 18(2):52–62
- Soini E (2005) Land use change patterns and livelihood dynamics on the slopes of Mt. Kilimanjaro, Tanzania. *Agric Syst*. Elsevier 85(3):306–323
- Tanner T, et al. (2015) Livelihood resilience in the face of climate change. *Nat Clim Change*. Nature Publishing Group 5(1):23
- Teklehaimanot A, Mejia P (2008) Malaria and poverty. *A N Y Acad Sci*. Wiley/Blackwell (10.1111), 1136(1):32–37
- Yu B, Fulginiti LE, Perrin RK (2002) Agriculture productivity in Sub-Saharan Africa. Annual Meetings of the American Agricultural Economics Association. California

**Open Access** This chapter is licensed under the terms of the Creative Commons Attribution 4.0 International License (<http://creativecommons.org/licenses/by/4.0/>), which permits use, sharing, adaptation, distribution and reproduction in any medium or format, as long as you give appropriate credit to the original author(s) and the source, provide a link to the Creative Commons license and indicate if changes were made.

The images or other third party material in this chapter are included in the chapter's Creative Commons license, unless indicated otherwise in a credit line to the material. If material is not included in the chapter's Creative Commons license and your intended use is not permitted by statutory regulation or exceeds the permitted use, you will need to obtain permission directly from the copyright holder.





# Climate Change Adaptation: Opportunities for Increased Material Recycling Facilities in African Cities

# 45

Gamuchirai Mutezo, Jean Mulopo, and Dumisani Chirambo

## Contents

Introduction .....	850
Towards Zero Carbon Cities .....	850
Objectives and Chapter Outline .....	851
Literature Review .....	852
Evolution of Sustainable Urban Planning in African Cities .....	852
Climate Change Adaptation .....	854
State of Waste Management in Africa .....	855
Material Recycling Facilities .....	859
Research Approach .....	861
Case Studies .....	863
Urbanization Dynamics .....	863
Urban Waste Impediments .....	864
Current and Proposed Strategies .....	865
Role of Informal Waste Collectors .....	867
Nationally Determined Contributions .....	869
Proposed Recommendations and Conclusion .....	869
References .....	871

This chapter was previously published non-open access with exclusive rights reserved by the Publisher. It has been changed retrospectively to open access under a CC BY 4.0 license and the copyright holder is “The Author(s)”. For further details, please see the license information at the end of the chapter.

G. Mutezo (✉) · J. Mulopo

School of Chemical and Metallurgical Engineering, Faculty of Engineering and Built Environment, University of the Witwatersrand, Johannesburg, South Africa  
e-mail: [mutezo.gamuchirai@gmail.com](mailto:mutezo.gamuchirai@gmail.com); [Jean.Mulopo@wits.ac.za](mailto:Jean.Mulopo@wits.ac.za)

D. Chirambo

Seeds of Opportunity, Blantyre, Malawi  
e-mail: [sofopportunity@gmail.com](mailto:sofopportunity@gmail.com); [info@seedsofopportunity.org](mailto:info@seedsofopportunity.org)

© The Author(s) 2021

W. Leal Filho et al. (eds.), *African Handbook of Climate Change Adaptation*,  
[https://doi.org/10.1007/978-3-030-45106-6\\_61](https://doi.org/10.1007/978-3-030-45106-6_61)

849

---

**Abstract**

Africa's urban morphology is expected to develop at a steady rate between 2020 and 2050. Population growth, rising urbanization rates, growing energy consumption, and industrialization are only a few of the reasons causing these changes. Likewise, waste production is projected to rise from 125 million tons in 2012 to 244 million tons annually by 2025. Around 60.0% and 80.0% of African waste is made up of organic material, which is a viable methane source. Fly tipping, free disposal, landfilling, and incineration have been used as a large-scale waste treatment system in most African cities. However, with the anticipated morphological changes, these solutions are no longer viable in the future due to lack of airspace, availability of urban land for new landfill sites, and concerns over carbon emissions. This chapter discusses the potential for improved adoption of material recycling facilities (MRF) in urban environments as an incentive to support waste diversion from landfills, decentralize waste separation activities, and increase the transformation of waste materials into valuable raw materials. A case study is discussed for Ethiopia, Ghana, and South Africa with the goal of explaining current processes, urban planning initiatives required for greater implementation, and how they can be interpreted as adaptation initiatives.

---

**Keywords**

African cities · Urban morphology · Waste management · Methane · Material recycling facilities

---

**Introduction****Towards Zero Carbon Cities**

Africa has 1.3 billion people (Worldometer 2020) and is the second largest continent after Asia. Many regional studies consider the socio-economic promise of the continent, propelled by urbanization, industrialization, and demographic growth. Achieving this potential would be confronted with a variety of obstacles. Solid waste management is currently one such problem particularly in urban areas. Ten of the fastest growing cities over the next decade are expected to be in Africa. Such cities include Luanda (Angola), Yaoundé (Cameroon), Dar es Salaam (Tanzania), Kumasi (Ghana), Kampala (Uganda), Lusaka (Zambia), Douala (Cameroon), Mbuji-Mayi (Congo), Antananarivo (Madagascar), and Tshwane (South Africa) (Knight Frank 2017). When these cities expand, accumulation of industrial waste becomes expected. Most African cities are generally planned and organized based on colonial urban planning (Home 2015). Little or no town planning has been undertaken since independence. That means little or no concern other than landfills and open dumps built in the 1960s and 1970s for urban waste management.



The main issue is the effect on carbon emissions in all municipal solid waste and cities. The African continent is vulnerable to climate change impacts. Urban areas are critical for effective adaptation to climate change (Revi et al. 2014). More than 50.0% of the world lives in urban areas and these communities partake in industrial practices that generate greenhouse gas (GHG) pollution. Socio-economic inequalities have also seen a dramatic rise in informal settlements in regions that are vulnerable to climate threats, such as natural disasters, public health, damage to homes, and income disruption. Inadequate provision of infrastructure and service delivery are exacerbating risks, especially for low-income households (Revi et al. 2014), and the pace of urbanization has exceeded the ability of many governments to handle it. In 2018, nine African cities pledged to achieve zero carbon cities by 2050. The cities include Accra (Ghana), Addis Ababa (Ethiopia), Dakar (Senegal), Lagos (Nigeria), as well as cities of Cape Town, Durban, Johannesburg, and Tshwane (South Africa). Nairobi (Kenya) and Abidjan (Côte d'Ivoire) are still expected to pledge. Drastic policy, human intervention, and finances will be required to reduce emissions from transport, construction, energy production, and waste management sector (The Economist 2018).

Waste management practices in Africa are not the most effective. Landfill alone contributes between 3.0% and 5.0% of overall industrial emissions (Zhang et al. 2019). Much of the academia and industry focuses on encouraging recycling practices not only as a method of waste disposal from landfills and open dumps, but also as a measure of climate adaptation and mitigation. Africa recycles only 4.0% of its total solid waste (Mohee and Simelane 2015; UNEP 2018). Before landfilling, further exploration of waste collection, separation, and beneficiation is necessary. More Material Recycling Facilities (MRFs) should be considered to boost recycling practices, waste data collection, and alleviate African cities from disposal pressures. Countries such as the United Kingdom have state-of-the-art engineered facilities that divert approximately 50,000 tons of waste per annum from landfills (Ali and Courtenay 2014). In the African context, academic research pertaining to MRF adoption and implementation is far and few in-between while industry or commissioned research is available but restricted between client and supplier. There is a global motivation to dispose of waste from open dumps and landfills as well as to reduce the contribution to emissions. With growth and urbanization proliferating in the coming decade, it is our view that urban planning has a role to play in rising MRFs as a way of mitigating the projected volumes of waste in urban areas.

## Objectives and Chapter Outline

Urbanization and population growth are anticipated to be significant drivers of climate change and pollution in the Global South. Currently, cities accommodate over half of the global population, generate approximately 82.0% of global GDP, account for 70.0% of global energy consumption, and account for over 70.0% of greenhouse gas emissions (Godfrey and Zhao 2016). However, it is estimated that by 2050 global, urban population will exceed 6.7 billion and that nearly 80.0% of

population growth will take place in low and middle income countries, where populations are already rising by over one million people per week (C40 Cities Climate Leadership Group 2016). There is therefore an urgent concern to increase climate change mitigation and adaptation efforts in African cities. Thus, the main objective of this chapter is to determine how material recycling facilities can be used as tools to facilitate climate change adaptation (and mitigation) in African cities.

To this end, the approach used consisted of exploratory case studies of three waste disposal activities in Ethiopia, Ghana and South Africa, and a review of secondary data, consisting of project reports and scholarly articles. The report is organized as follows: section “[Literature Review](#)” addresses the evolution of urban planning in Africa and contextualizes the relationship between climate change and waste management in Africa as well as the rationale for improving waste management and introduces Material Recycling Facilities, how they are planned and designed. The aim is for readers to have an appreciation before going into the case studies. Section “[Research Approach](#)” discusses the exploratory case study approach. Section “[Case Studies](#)” discusses whether Ethiopia, Ghana and South Africa have urban, waste management, and climate change adaptation plans, strategies, and projects relating to MRFs. Section “[Proposed Recommendations and Conclusion](#)” offers climate change and waste management practitioners recommendations and concludes with an assessment of urban planners’ roles and responsibilities.

---

## Literature Review

### Evolution of Sustainable Urban Planning in African Cities

Africa’s towns and cities are shaped by laws imported from British colonial rule from the 1920s (Home 2015). Urban Planning, interchangeably referred to as Town and Regional Planning or City Planning, is a discipline within the built environment that is concerned with designing and developing land use (Lubida et al. 2019). It was officially recognized as a profession in the latter twentieth century (Home 2015). Key considerations range from transportation, engineered utilities (water, electricity, sewerage systems), infrastructure, communication, and social amenities (schools, hospitals, parks, economic activities). Spatial and land use planning are the most predominant specializations in the field of urban planning. This is a dynamic activity that requires juggling social, cultural, environmental, and political influences (Lubida et al. 2019). Decisions surrounding zoning, subdivision, and urban planning are taken by land use authorities, in consultation with different stakeholders (Home 2015). Amenities such as waste management have not been deliberate in planning strategies. While there is a global push for cities to become more environmentally responsive and to implement mitigation and adaptation initiatives through policies and strategies – Sustainable Development Goal 13, Target 13.2 – current urban systems are not conducive. A large part of African cities are still centered around colonial town planning principles and regulation, with a morphology characterized

by informalities – informal settlement, informal structures, and informal waste pickers.

Postindependence, there was very little evidence of the evolution of land use planning, especially the form that supports sustainability. Throughout the 1980s and 2000, several academics started to re-invent postmodern planning, one driven by economic development and environmentalism (Okeke and Nwachukwu 2019). An increasing body of literature on urban sustainability and innovative planning approaches has begun to shift urban development patterns (Lwasa and Njenja 2012). The term “green technology” was identified as a tool for modern urban planning. This includes deliberate coordination of activities that are energy efficient and promote renewable energy, recycling activities, and more. There are different technologies that contribute towards sustainable urban planning, such as the implementation of enhanced municipal waste management (Laffta and Al-rawi 2018). Four types of eco-technologies that urban planners can start implementing more are:

1. Environmental Technology: a range of technologies relating to waste management, access to water and energy
2. Information Technology: hardware and software coupled with environmental sensor technology to collect environmental data
3. Geographic Information Systems: collect, share, manipulate geographic data and incorporate with Urban Information Systems to guide design and development of land use and environmental plans
4. Communication Technology: software to transfer data and knowledge to different environments

Green technologies are most prevalent and commercialized in Denmark, Sweden, Japan, India, Iraq, Finland, Canada, and the United States of America, just to name a few (Laffta and Al-rawi 2018). Opportunities for African planners to leapfrog are bountiful. Such tools can be used not only for sustainable urban development and waste management but as part of climate mitigation and adaptation strategies. Kenya is not far from realizing the benefits of green technologies. Urban planners are responsible for solid waste management. The National Solid Waste Management Strategy is used to incorporate solid waste management and best practices into urban plans. The plans are then subjected to a Strategic Environmental Assessment, which assesses aspects such as sustainability, proposed waste management programs, as well as relevant services and facilities (Ozoike-Dennis et al. 2019). The authors further state that *solid waste management* (SWM) plans are included in the *Nairobi Integrated Urban Development Master Plan* (NIUPLAN). The SWM plans focus on “improving waste collection and transportation system, closing open landfills, and constructing Material Recovery Facilities, where waste material is to be separated to compost biodegradable material, and recycle non-biodegradable material.” In South Africa, municipal departments in charge of solid waste management are required to develop Integrated Waste Management Plans as stipulated in the National Environment Management: Waste Act (59 of 2008). The IWMPs include practical aspects of

managing waste in municipalities. It is one of the sector plans that feed into and is guided by the Integrated Development Plans (Sango et al. 2014).

## Climate Change Adaptation

The mean annual temperature in Africa increased by 1.7 °C in the last two decades of the twenty-first century and temperatures are expected to increase faster than the global average in the last two decades (Revi et al. 2014). It negatively impacts on livelihoods, health and sanitation, access to water, agricultural production, and urban infrastructure as well as slows down sustainable development (Reda and Tripathi 2011). Climate change demands new sustainable development strategies through mitigation and adaptation measures. Africa generates just 4.0% of global pollution, but will suffer serious consequences (Reda and Tripathi 2011). Field et al. (2014, p. 1104) define adaptation as a “response strategy to anticipate and cope with impacts that cannot be (or are not) avoided under different scenarios.” Adaptation has to do with strategies and plans that can be implemented. They should be linked to development strategies and plans and disaster risk management. By doing this, developmental benefits are identified for the shorter term while reducing vulnerabilities in the longer term (Mimura et al. 2014). The importance of adaptation is influenced by how the issues are outlined (Mimura et al. 2014). They are heterogeneous and very few have been monitored and evaluated in great detail. The process of adaptation planning is a complex social process that can create unrealistic expectations. It is done at a national level and implemented at a local level. However, poor coordination as well as recent and quality data can also impede the transition from planning to implementation, as is the case for many developing and developed countries (Mimura et al. 2014).

Accordingly, adaptation responses differ from context to context and involve a multiscale perspective which takes into account cultural, social, environmental, and institutional factors. If climate change is moderate, sustainable development will be greater and if it is high, sustainable development has less impact (Field et al. 2014). It involves designing strategies in the sense of waste management which reduce generation. Given the expected population growth, waste generation is unavoidable. Several primary practitioners interested in adaptation responses are environmental planners as they are planning for physical environments, environments impacted by disasters of climate change (Mimura et al. 2014). They build land use plans enabling or avoiding climate-risk projects (Revi et al. 2014, p. 8). City planning and land management are important (but certainly not the only) resources for policymakers to create climate-resilient city systems and construct capacity for sustainable urban growth at local level, connecting adaptation and mitigation steps, and enhancing livelihoods and quality of life for urban communities. Attention should shift to integrated development planning (Reda and Tripathi 2011). Today, African cities face a critical urban situation marked by a failure of governance structures in the face of increasing waste production combined with strong demographic growth and proliferation of slums and poverty. Strengthening waste management capability is

critical for fostering smart urban growth and maintaining cities' democratic, economic, and social stability.

Greenhouse gas emissions from urban waste in developing countries are expected to increase drastically in future (Friedrich 2013) which may result in increased emissions from the waste sector. Increasing recycling, anaerobic digestion, and composting activities can reduce emissions. Waste material is not the only aspect of the value chain contributing towards emissions. Collection and transportation consume approximately 5 dm<sup>3</sup> (liters) of diesel per ton of waste, which accounts for 15 kg CO<sub>2</sub>e emissions from landfilling alone range from 145 to 1,016 kg CO<sub>2</sub>e per ton of wet waste. Aerated and turned windrow composting releases between 172 and 186 kg CO<sub>2</sub> per ton of wet waste (Friedrich 2013).

Globally, landfills contribute 3.0% to 5.0% of total global emissions (Zhang et al. 2019) because methane gas is the main carbon emission (Couth and Trois 2012). In Africa, it remains the cheapest and most common disposal method. Landfills are categorized as controlled or uncontrolled dumping or semi/medium/highly engineered facilities. The status of landfill classification structures in sub-Saharan Africa between 2000 and 2018 was evaluated by Idowu et al. (2019). To name a few, they identified 31 landfill sites across South Africa, Botswana, Cameroon, Ghana, Uganda, Kenya, Tanzania and found that 80.0% were listed as 0 and 1 (where 0 was classified as open dumpsites and 1 as controlled tipping). Classifications as non-engineered landfills make it difficult to beneficiate waste and manage environmental impacts such as leachate, groundwater contamination, air borne particulates, and pollution. Vaccari et al. (2019) conducted a technical review of leachate characteristics in landfills and open dump engineering in developing countries. The authors found 21 engineered landfills and 13 dumpsites across Africa as well.

## State of Waste Management in Africa

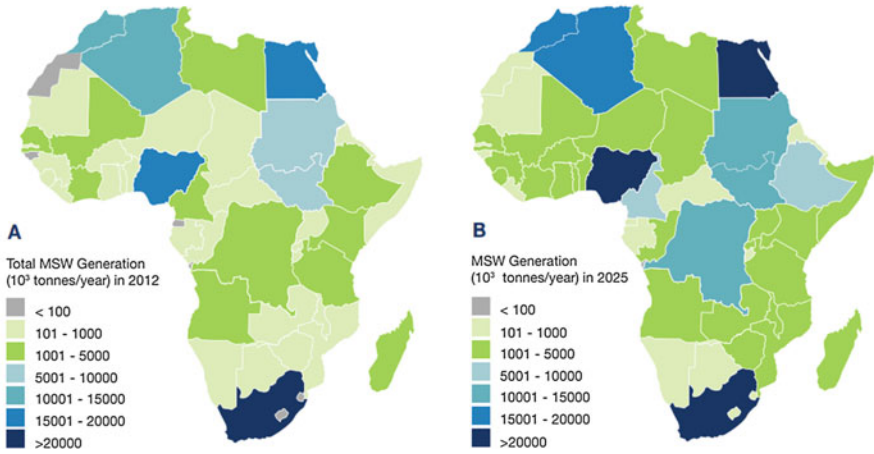
Local authorities in developing countries are facing significant waste management problems as a result of an increasingly rapid rise in locally generated quantities and the complexification of the forms of waste to be handled. Informal waste collection is also used as an external constraint: it usually takes place under unstable social and environmental circumstances and, a priori, makes waste disposal more complex, managed by a multitude of minor actors. Moreover, data on waste quantities, characteristics, and source is a major impediment particularly for proper planning, implementation, monitoring, and evaluation. Most of the data in this section is based on 2005 and 2012 statistics, which was also used to forecast waste proliferation by various regional bodies, namely, the United Nations Environmental Programme. The daily ratio is the amount of waste generated per capita and per day. Its knowledge is a crucial phase in the introduction of waste management approaches. The amount of waste produced is always very heterogeneous and variable depending on the region, the lifestyles and culture, and the socio-economic level. Changes in lifestyles, living habits, consumption, and demographic growth have a significant effect on the quantity and typology of waste generated. This development often varies from one

city to another within the same region, or from one district to another within the same city also according to peoples “living conditions.” In sub-Saharan Africa, though per capita waste production rates are lower than in other areas of the world, high population growth, combined with increasing urbanization, would increase unbearably waste generation beyond existing capacities. In this regard, Kaza et al. (2018) forecasts that the overall quantity of waste in Africa will double from 174 million tons per year in 2016 (2.1 billion tons globally) to 269 million tons by 2030 (3.4 billion tons per year in 2025). Africa’s waste generation accounts for 9.0% of total global waste generation (Kaza et al. 2018). Developing countries generally have an average annual production of waste per capita ranging from 180 kg to 240 kg, a quantity that is likely to double as a result of industrialization and the evolution of production and consumption patterns if adequate measures are not taken to influence this progression.

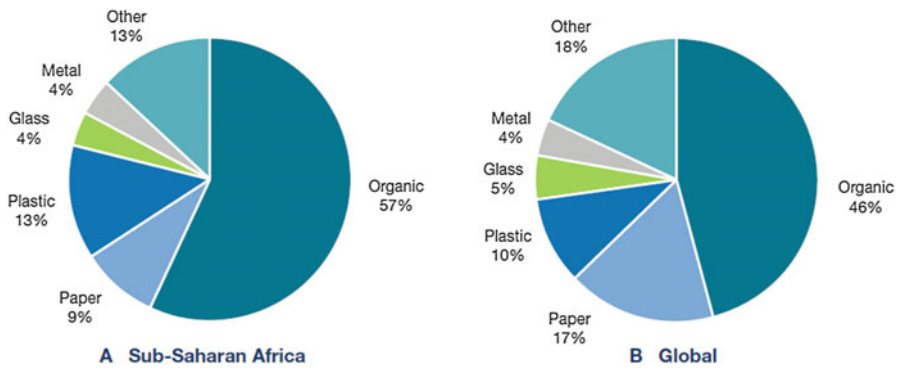
*Waste Services and Infrastructure:* Municipalities are responsible for providing waste related services in most African cities (Friedrich 2013; UNEP 2018). Infrastructure includes but not limited collection, transportation, recycling, treatment, disposal, and beneficiation in some cases. However, expensive and insufficient capacity limits their ability to provide sound infrastructure and quality services to all its customers. Lack of payment by customers has a direct impact on municipalities’ waste management budget, which restrains their ability to ensure quality services and infrastructure. To deal with this issue, private sector companies and community based organizations partner with municipalities (UNEP 2018). There is a relationship between Willingness to Pay (WTP), affordability, and quality of services rendered.

*Waste Generation:* In 2012 Africa generated an estimated 125 million tons, 65.0% of which was sub-Saharan Africa (80 million tons), and by 2016 it was an estimated 174 million tons. Waste generation is expected to more than double to 244 million tons per annum by 2025 (UNEP 2018) to 269 million tons in 2030 and 516 million tons by 2050 (Kaza et al. 2018). Some of Africa’s big economies, comprising of Algeria, Nigeria, South Africa, Ethiopia, and Egypt, are expected to be some of the biggest generators of waste. The forecasted growth is likely to adversely impact the climate if adaptation and mitigation measures are poorly implemented (Fig. 1).

*Waste Composition:* Waste composition has direct implications about how it is collected and disposed. Increasing raising living conditions are correlated with a qualitative shift in waste. As a country’s income rises, the biodegradable ratio of the waste often declines as plastic, paper, and other industrial material waste rises (Hoorweg and Bhada-Tata 2012). The environmental effects of such a qualitative mutation are negative as nonbiodegradable waste takes more time to decompose. For Africa, the organic component is still the largest and emits a lot of methane, but it is likely to decline with the economies “industrialization movement.” Fifty seven percent (57.0%) of MSW comprises of organic matter (Couth and Trois 2012; Mohee and Simelane 2015; UNEP 2018), followed by plastic (13.0%), paper and cardboard (9.0%), glass and metal (4.0%each), and other material (13.0%). However, composition varies from country to country, depending on economic activities, income level, consumer attitudes, and culture (UNEP 2018) (Fig. 2).



**Fig. 1** Total MSW generation ( $10^3$  tons/year) of African countries in 2012 (a) and 2025 (b)<sup>3</sup> (UNEP 2018)



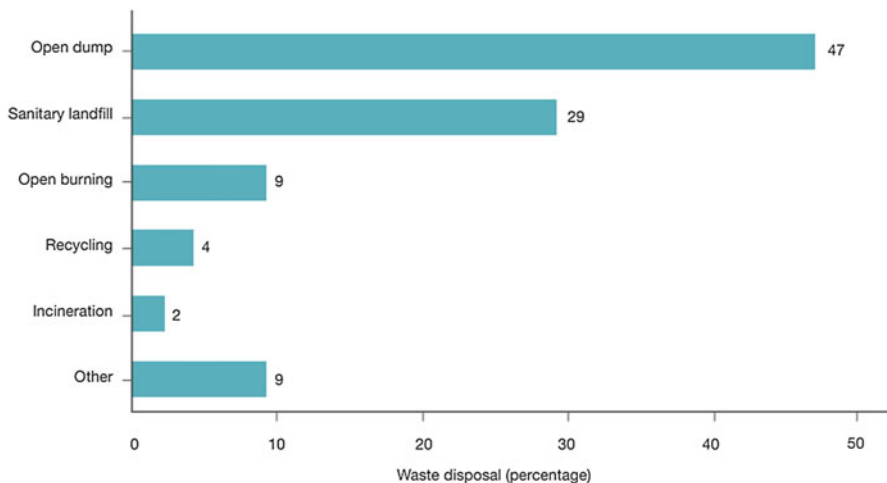
**Fig. 2** Municipal solid waste composition (UNEP 2018)

*Waste Collection:* Uncollected waste remains very large in Africa. It might be necessary to note, however, that certain African cities have adopted improved management selection techniques. Some work has shown a spike in private-sector collections (UNEP 2018). Choosing a treatment method entails multiple economic, social, and environmental factors such as waste generation, population density, and location of waste collection centers (Mohee and Simelane 2015). Unregulated landfills and informal recycling are the main waste disposal methods in African countries and there is a high demand for waste services and low supply. Majority of the budget for MSW in developing countries is spent on waste collection yet only 55.0% of total waste generated was collected. Although waste collection is expected to increase to 69.0% by 2025 (UNEP 2018), where it will be disposed remains a

concern. Collection services are most present in urban areas compared to suburban and rural areas. A common practice is door-to-door collection, by both public and private sector contractors. In peri-urban areas, community-based organizations are very important.

*Disposal Methods:* Landfilling and open dumping are the most common waste practice on the continent because both are considered the cheapest forms of disposal (UNEP 2018). Landfills are categorized differently, but the most common categories are controlled and uncontrolled. The nature of landfills and open dumps have little to no consideration for human health and the environment. Poor sanitary engineering and waste treatment results in groundwater contamination, leachate overflow, and an unpleasant stench. Across most landfills and open dumps in Africa, scavenging activities are inevitable (Idowu et al. 2019). Households near disposal sites are exposed not only to waste-borne diseases, but sharp objects and dangerous chemical excretions. Furthermore, GHG emissions are exacerbated due to poor waste minimization prior to disposal and open burning (9.0%). As the sites become full, the disposed waste is burned in order to reduce volumes and create more space (Fig. 3).

*Opportunities for waste recycling:* Most literature about recycling acknowledges the opportunities presented by such activities. In the African context, a lack of empirical data is one of the reasons why it is not a common practice particularly within the public sector. Recycling is not a well-known method in most municipalities, and this may be attributed to a lack of knowledge. Recycling activities are done by private contractors and informal waste pickers and they represent only 4.0% of total recycling activities on the continent (UNEP 2018). Although these are positive strides, waste material from developed countries continues to be dumped and lead to new waste streams, and most municipalities are not well equipped with the necessary logistics required for handling recycling. The informal sector, which comprises of mainly waste pickers, largely practices recycling for economic reasons. They play an important part towards reducing



**Fig. 3** Methods of end-of-life MSW disposal in Africa (UNEP 2018)



carbon emissions (Nzeadibe 2013; Oduro-Appiah et al. 2019). Recyclables such as plastic, glass, paper, and metals are supplied to commercial businesses. Organic waste which releases the most emissions due to its CH<sup>4</sup> composition is seldom recovered for large-scale impactful composting. Waste pickers in South Africa save municipalities an average of US\$30 – US\$70 million annually in landfill airspace, with little to no financial or operational support (Godfrey et al. 2016).

## Material Recycling Facilities

There are many alternative waste management options available but not all are economically or contextually viable for the continent. Recycling activities and energy recovery technologies are currently being implemented but both on a very small scale. Technologies that can be reviewed are biological treatment, mechanical biological treatment, thermal treatment (incineration, gasification, and pyrolysis), and material recycling facilities (UNEP 2018). As mentioned in previous sections, Africa's recycling rate is only 4.0% annually. Municipalities are impeded by financial and infrastructure costs and private sector recyclers' business models do not cater to all waste producers due to affordability. Informal sector recyclers are an important aspect of the waste value chain (Godfrey et al. 2016). Material recycling facilities are an integral part of an integrated waste management model and offer a great opportunity for all the role-players to converge. The study focuses on material recycling facilities due to their ability to be implemented immediately, contextually, and cost-effectively.

*Defining MRFs:* An MRF is a plant where waste is received, sorted, and processed for revenue generation and to reduce negative environmental externalities (Hosansky 2018; Zafar 2019). The plants can be classified either as dirty or clean. Dirty MRFs process mixed waste which requires a lot of manual labor while clean MRFs tend to process waste that was separated at source and reduces waste contamination. MRF sizes vary from context to context. Zafar (2019) states that small MRFs process less than 10 tons per day and price ranges between US\$500,000 and US\$1 million. Price determinants are costs of building material, location, and the level of automation required. Large MRFs process more than 100 tons per day and are usually located in large cities. Due to the high automation process, the budget runs into millions of dollars. In a study by South Africa's Department of Environmental Affairs (2019), large MRFs can process between 1,200 and 1,500 tons of waste per month while small MRFs can process between 300 and 500 tons per month. Despite the varying sizes, MRFs have an important role within the waste value chain, primarily to improve waste separation and reduce waste streams before implementing additional management methods – see Fig. 4.

*Role-players and Decision-Makers:* there are many role-players along the waste value chain and their level of involvement is based on different contexts. Traditional actors include municipalities, private sector (business and industry), the informal market, waste producers, and civil society. Effective or noneffective coordination determines the level of successful implementation. During the planning stages, different levels of planning and decision-making constituencies in municipalities

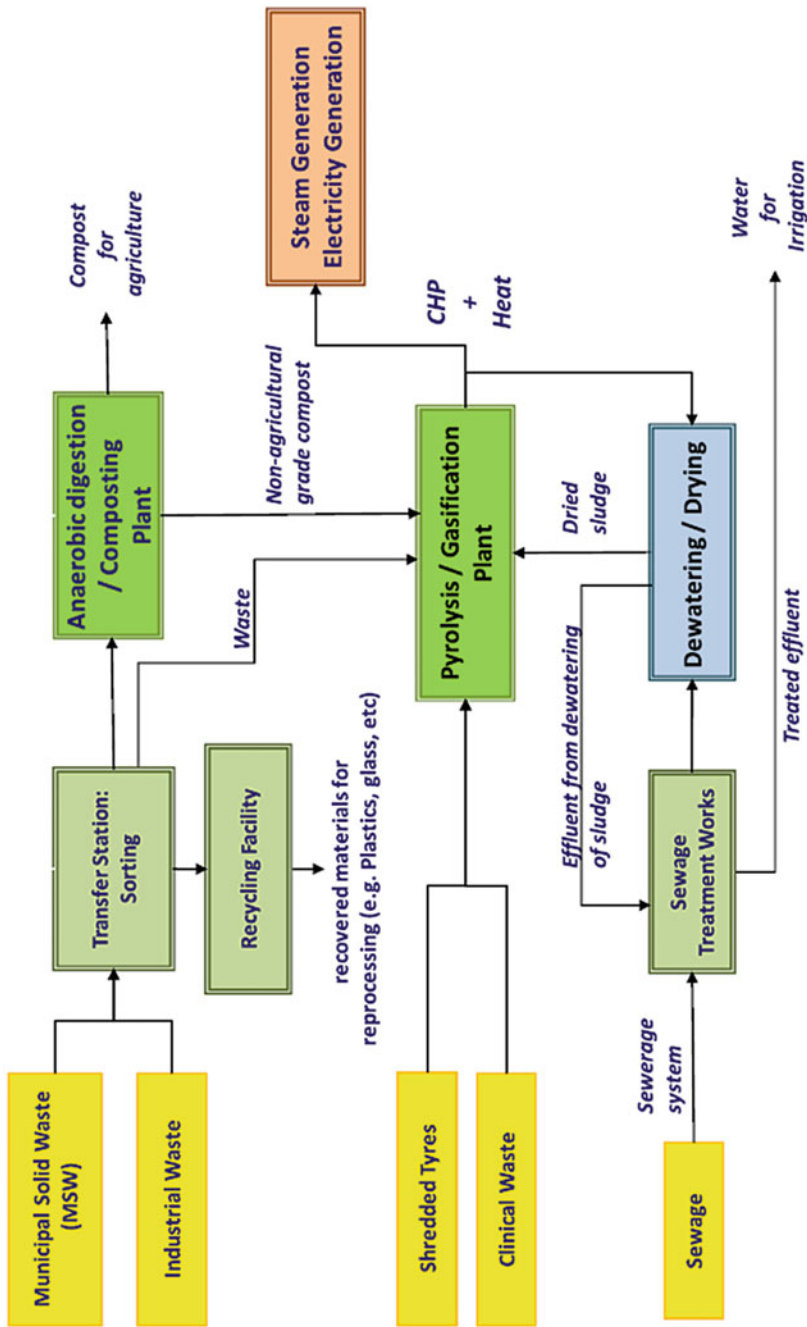


Fig. 4 Integrated waste treatment system (Trois 2014)

are involved. They need to be aligned to ensure sustainable waste management is implemented. According to Sango et al. (2014, p. 223) “*stakeholders in solid waste management include, but are not limited to, solid waste managers, technical/utility managers, municipal managers, chief financial officers, mayors, councillors and the public at the local municipal level.*” Their lack of involvement can negatively or positively impact technical design due to incorrect data, poor policy, and regulation considerations and accurate budgeting for building material and equipment. This is seen in the growing body of literature encouraging informal waste pickers to be integrated into solid waste management strategies.

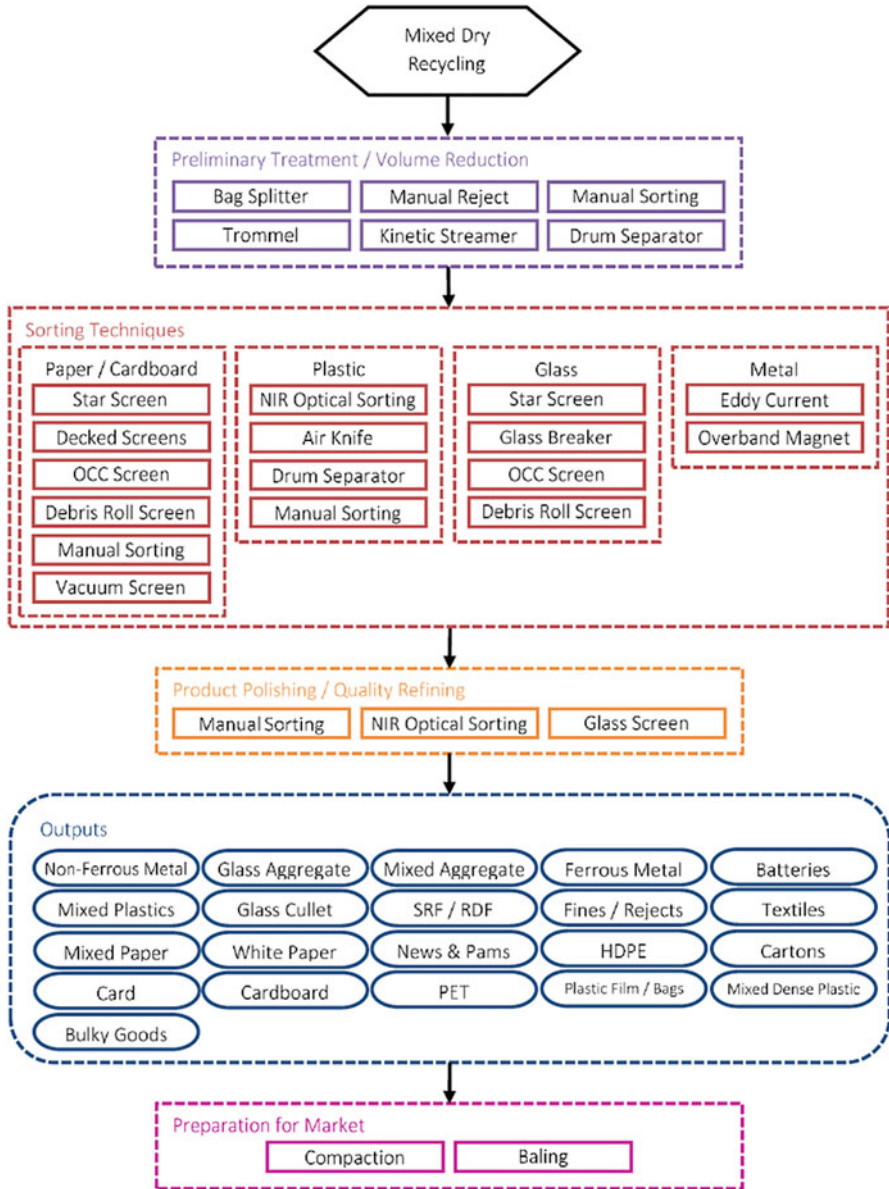
*Technical Design Considerations:* Good knowledge and data on waste quantities and characteristics are imperative to an MRF’s efficiency. However, 100.0% material recovery is not guaranteed due to the quality of materials and sorting efficiency as well as market conditions. Figure 5 presents a technical design for a proposed dirty MRF in South Africa. When waste arrives at the plant – either in waste bags or trucks – it is taken for preliminary treatment where waste volumes are reduced. Equipment such as bag splitters is used together with manual laborers to tear waste bags in preparation for sorting. At this stage, recyclables are sorted depending on the waste characterization (paper, plastic, glass, and metal). The quantities determine whether sorting will be entirely manual, semi-automated, or fully automated. Manual sorting is still important particularly for quality control purposes (Cioca et al. 2018; Department of Environmental Affairs 2019). The recyclables are then compacted and prepared for the market, for composting, and anaerobic digestion or residual is taken to the landfill.

*Financing and Economic Instruments:* It is important to standardize what a big and small MRF design will look like. The design should consider waste generation quantities and offtake markets for recyclables, supply and demand principles. Although mechanical MRFs are considered more economic because they can process 3.0 tons per hour with approximately seven operators compared to manual MRFs that process 1.0 ton per hour with 12 operators (Cioca et al. 2018), labor intensive activities should be highly considered in the African context because of job creation opportunities. Financing models range from public-private partnership, to fully publicly owned and operated. The proposed model is a public-private partnership where risks are shared and efficiency is maximized (Department of Environmental Affairs 2019). Economic instruments such as subsidies and taxes are designed to change consumer behavior. In the case of waste, they aim to reduce waste generation or induce waste diversion from landfills and dumps to recovery and recycling activities. Furthermore, they can also be used as a source of revenue for municipalities and implement service delivery (Nahman and Godfrey 2010).

---

## Research Approach

An exploratory case study research approach was used. This involved empirical investigation of current consideration of MRFs in urban, waste management, and climate adaptation plans and strategies in selected African countries. The exploratory approach is intended to provide an understanding of what is available and set



**Fig. 5** Material recycling facility process (Department of Environmental Affairs 2019)

precedent for future investigation with participants and be more descriptive. Ethiopia, Ghana and South Africa were identified as targeted case studies based on three primary criteria: countries with the fastest growing cities in the respective regions, cities that committed to become zero carbon by 2050, and cities with some data on recycling, landfills, and open dumps – see Table 1. Selecting a case study

**Table 1** Case study selection criteria of cities

Fastest growing	Committed to be carbon free	With landfills and open dumps
Angola (Luanda)	<i>Ethiopia (Addis Ababa)*</i>	Botswana
Cameroon (Douala)	<i>Ghana (Accra)*</i>	Cameroon
Cameroon (Yaonde)	Ivory Coast (Abidjan)	Dem.Rep of Congo
Dem.Rep of Congo (Mbuyi-Mayi)	Kenya (Nairobi)	<i>Ethiopia*</i>
<i>Ghana (Kumasi)*</i>	Nigeria (Lagos)	Gambia
Madagascar (Antananarivo)	Senegal (Dakar)	<i>Ghana*</i>
<i>South Africa (Tshwane)*</i>	South Africa (Cape Town)	Guinea Bissau
Tanzania (Dar es Salaam)	South Africa (Durban)	Kenya
Uganda (Kampala)	<i>South Africa (Johannesburg)*</i>	Namibia
Zambia (Lusaka)	South Africa (Tshwane)	Nigeria
		Sierra Leone
		<i>South Africa*</i>
		Tanzania
		Uganda
		Zimbabwe

**KEY:** \* = countries with the fastest growing cities that are committed to being carbon free and have landfills/open dumps

per region allows for a comparative exploration. Secondary and grey literature provided further support and rationale for selecting these three countries. Two challenges experienced with Francophone and Lusophone countries were firstly, limited availability of recent data and secondly, some available data is presented in French and Portuguese.

## Case Studies

Based on the range of impediments identified in section “[Literature Review](#),” the case studies explore whether the identified countries have urban, waste management, and climate change adaptation plans, strategies, and projects relating to MRFs. Discussions are themed according to factors used to determine suitable MRF design and adaptation planning, such as (1) Urbanization Dynamics, (2) Urban Waste Impediments, (3) Current and Proposed Strategies, (4) Role of Informal Waste Collectors, as well as (5) Nationally Determined Contributions (NDCs) focusing on waste management technologies.

### Urbanization Dynamics

As in many African countries, rapid urbanization in Ethiopia, Ghana, and South Africa is a result of increasing economic activities particularly in large cities. Addis

Ababa is the capital city and seat of the Federal Republic of Ethiopia. It has a current population of 3.3 million (23.8% of all urban dwellers) and extends across 540 km<sup>2</sup> of land space. The administration is known as a City Government and it has 10 subcities known as *Kebele*. In Western Africa, the City of Accra – which is part of the Greater Accra Metropolitan Assembly – is the capital city of Ghana and accounts for 20.0% (1.5 million) of the country's total population (The World Bank 2017). More than 53.0% of Ghana's total population currently reside in urban areas and this figure is projected to reach 65.0% by 2030. The Accra Metropolitan Assembly (AMA) is responsible for all local government activities within Greater Accra. Further down south, the City of Johannesburg (CoJ) is the largest city in South Africa. With a population of 5.6 million (66.4%) spanning across 11 regions and 1,645 km<sup>2</sup> of land space. Like its counterparts, the City of Johannesburg Metropolitan Municipality is responsible for service delivery. Provision of basic amenities and infrastructure has not kept up with the urbanization rates in all three cities, thus resulting in more urban tensions such as social unrest and sprawling which induce climate change impacts.

## Urban Waste Impediments

Waste management and poor sanitation infrastructure are a few of the services that governments continue to grapple with especially in low income areas. In 2013 Accra was generating 2,200 metric tons of waste per day and approximately 1,500 to 1,800 tons was collected by private sector. Between 2017 and 2018, generated quantities increased to 3,000 tons per day (Accra Metropolitan Assembly 2019). Waste collection and transportation alone cost the metropolitan GHC 450,000 (approximately US\$77,000) per month and an additional GHC 240,000 (approximately US\$41,000) to maintain dumpsites, resulting in 58.0% of waste and sanitation budget being spent on collection and transportation (Accra Metropolitan Assembly 2019). One of the factors that made collection and transportation difficult was the city's spatial planning. Oteng-Ababio et al. (2013) stated that “*Accra did not have the advantage of being a wholly planned city, since spatial planning was introduced after the town had developed on its own. Spatial planning is inconsistent at best, with semblances of colonial-era planning in (some) indigene areas such as Old Accra and Korle Gonno in Ga Mashie while migrant communities such as Nima, Sabon Zongo and Old Fadama continue to grow unplanned. Such unplanned settlements tend to be classified as ‘poverty pockets’ in the city, with a history of poor municipal investment in infrastructure services and under- and unemployment (particularly among the youth)*” (p. 98), resulting in lasting impacts on sanitary service delivery. Tuani (2008) resonates with the authors by stating that the unplanned nature of the city increased waste management issues, in particular land acquisition for landfills/open dumps and waste disposal sites. Additional challenges include poor separation at source, limited recent data, and limited optimization of other disposal plants.

Similarly, in Addis Ababa, waste collection and disposal are poorly managed. Citizens generate 730,000 metric tons of waste per annum (between 2,200 and 3,000 tons per day). Koshe landfill is the only landfill and biggest one in the city. It is located 13 km in the outskirts of Addis Ababa and the travel distances from other parts of the city make it inaccessible and costly. This results in poor collection and disposal in the nearest area. Just over 65.9% is collected by the metropolitan municipality and the remainder is disposed in unauthorized areas such as open fields, streets, ditches, and any available space within the city. Citizens do not have conviction in the metropolitan's ability to deliver waste management services, resulting in limited to no cooperation with waste related operations. Urban development and sprawling are occurring at a rate that government cannot service all households (Geda et al. 2011). Poor urban and road infrastructure make it difficult to collect data in highly dense settlements, further exacerbating effective implementation. The same sentiments are shared by Johannesburg where residents generate 1,492,000 tons of waste per annum and the four landfills cannot continue taking (City of Johannesburg Municipality 2011). Although other disposal measures such as recycling and composting are part of the city's management strategy, effective implementation is challenged by urbanization dynamics. In 2015, the Department of Environmental Affairs estimated that Johannesburg had between 5 and 8-years landfill airspace remaining (Department of Environmental Affairs 2018). Fast track to 2020, at least 5 years are up and pressure is increasing with population growth.

## Current and Proposed Strategies

In Accra, AMA introduced two collection methods to help streamline collection and transportation: Communal Container Collection (CCC) and HtH (house-to-house). Households were required to pay a monthly collection fee, but those residing in low-income areas were daily and weekly wage-earners, they could not afford the service. Furthermore, areas where CCCs were located had bad road infrastructure. This presented locality and accessibility challenges. Since then there has been an increase in private sector participation, particularly waste collection. Affordability remains an impediment. Because waste was poorly collected, it was difficult for AMA to promote source separation. The ripple effect was poor planning and implementation of other disposal methods like composting, digestion, and recycling. Almost a decade later, waste management officials cite (1) community awareness, (2) effective collection systems, (3) limited disposal capacity, and (4) unplanned nature as ongoing challenges. Figure 6 discusses an investigation of Accra's urban planning, waste management and climate change plans and strategies to ascertain consideration for MRFs as an adaptation tool.

In the far East, containers are placed in common places each Kebele, close to main roads where waste trucks can access. Pushcarts are used to collect waste from each household at a fee. Those who cannot afford the fees carry their own waste to the container. Services are provided by Kebele workers and street sweepers (Cheru 2016). In 2017, the Reppie Waste-to-Energy Facility was commissioned, producing 25 MW of

#### Plans and Strategies - Accra

Accra Spatial Development Framework (2017) recognizes the various challenges presented by poor waste collection and disposal propelled by insufficient infrastructure and urbanization. It proposes that AMA 'explores job creation and economic opportunities associated with engineering service delivery, for example decentralize waste collection to locals / individuals. Furthermore, preparation and implementation of sanitation action plans for all leading urban centers, including related statutory regulations and by-laws ensuring effective collection, disposal and treatment of solid, liquid and toxic waste. The ASDF also proposes New Solid Waste Management Schemes and Environmental and Land-Use Policies but is not explicit about disposal methods, location determination or MRFs. Although it states that district level climate change mitigation and adaption strategies must be developed in order to plan for and implement requirements for climate change, additional details are not provided. However, detailed consideration is given in the Ghana National Climate Policy (2013). The policy recognizes the opportunities presented by beneficiating waste, problems with land acquisition for waste disposal as well as the need to increase recycling activities as means to reduce carbon emissions. It is reported that in April 2020, AMA entered into a public-private partnership (PPP) for Waste Transfer Site and Material Recovery Facility (MRF). Zoomlion currently operates a 200-tonne recycling plant in Accra. No reference of MRFs in Integrated Urban Environmental Sanitation Master Plan (IUESMP), Metropolitan Land Use and Transport Plan for Greater Accra Region, Emergency Solid Waste Management Improvement Programme 13 (E-SWMIP), the Accra Climate Strategy and Integrated Urban Environmental Sanitation Strategy and Master Plan.

**Fig. 6** Investigation and discussion of MRF consideration in Accra. (Source: Author's own compilation)

electricity. The facility is located next to Koshe Landfill site and waste has since been diverted for incineration instead, thus reducing emissions. There are traces of recycling activities but on a small scale at disposal sites (Geda et al. 2011). Private sector, community-based organizations, informal waste pickers, and international donor agencies are the main participants promoting some levels of at source separation and income generating activities. IGNIS was a joint project between Ethiopian and German partners. The project started in 2014, with the aim of implementing *income generation and climate protection by valorizing municipal solid waste in a sustainable way in emerging mega cities*. Strategies included creating individual waste recycling projects that could create employment and income opportunities while reducing GHG emissions. The project lasted until 2018 and provided valuable data to waste management agencies, namely composting (Gerji and Ataklet Tera Composting pilots) and biogas (Sidest Kilo and Menelik II preparatory School pilot) (Cheru 2016). Figure 7 also investigates Addis Ababa's urban planning, waste management, and climate change plans and strategies to ascertain consideration for MRFs for adaptation.

Johannesburg has better waste management infrastructure and initiatives. Pikitup is CoJ's waste management agency responsible for collection and disposal across 11 regions. As with many cities on the continent, increasing urbanization trends are causing strain on quality service delivery. CoJ has numerous private-public-partnerships throughout the waste value-chain to reduce the high costs of collection and disposal incurred. Most PPPs fall within waste collection and disposal. Formal urban areas have scheduled collection dates and residents have municipal bins. Some informal areas do have some sort of waste service and others do not. This results in pockets of illegal dumping. There are four landfill sites in different ends of Johannesburg and all four have reached their airspace capacity. Although CoJ has championed waste diversion activities such as recycling, composting, and pilot projects for small scale biogas projects, there is a need to increase these activities. The recycling sector is relatively well established compared to Accra and Addis Ababa. Associations such as South African Plastics Recycling Organization, National Recycling Forum, and the Institute



**Plans and Strategies – Addis Ababa**

Addis Ababa City Structure Plan (2017-2027) shares strategic plans and land use tools to improve urban development in the city. It recognises waste and climate related challenges as well as the need for improved recycling activities. The CSP states that it is preferable to make use of a mix of centralized and decentralized offsite and onsite liquid waste management systems as well as wastewater treatment technologies that do not consume large tracts of land. Interestingly, the plan proposes that three transfer stations with material recovery facilities (south, east, west) should be developed at each waste transfer station. The Draft Work Plan for Addis Ababa - Climate and Clean Air Coalition, prepared by the U.S. Environmental Protection Agency (2015) addresses the direct relationship between climate change and improved waste management.

The World Bank has a number of urban and climate change related projects underway in Addis Ababa. 'Enhancing Urban resilience Programme' was launched in 2013 to help cities strengthen their ability to prepare for and adapt to changing conditions, and to withstand and recover rapidly from disruptions related to climate change, natural disasters, and other shocks and stresses. The programme serves as an umbrella for delivering the analysis, rationale, and support local governments need to make resilience part of their urban management agendas. The 'Urban Local Government Development Project' (2008-2014) was designed to financially support the Ethiopian government "to support improved performance in the planning, delivery, and sustained provision of priority municipal services and infrastructure by urban local governments", inclusive of waste infrastructure.

**Fig. 7** Investigation and discussion of MRF consideration in Addis Ababa. (Source: Author's own compilation)

**Plans and Strategies – Johannesburg**

Various national policies require municipalities to develop Integrated Waste Management Plans (IWMPs) and Integrated Development Plans (IDPs) every five years. The IWMP recognizes that development planning in the City must also consider waste service provision and therefore early engagement and communication between planners and those involved in waste management is needed. Composting facilities, MRFs and buy back centers are noted as action plans for waste diversion. Similarly, the IDP 2018/19 acknowledges the need to improve waste management infrastructure supportive of waste minimization and recycling as well as climate change. CoJ has Environmental Sustainability Strategy and Action Plan (2019) encourages spatial transformation in cities. This includes applying existing and develop municipal planning instruments to integrate and secure ecological infrastructure into the urban fabric.

Tedcor piloted a materials recovery facility (MRF) in Wadeville, near Germiston in Gauteng, in partnership with local buy-back centers. Droplets for Life – a private waste management company - have their own MRF situated in Wadeville, Gauteng. They receive waste through this facility from clients and from their own waste. The facility processes approximately between 25 to 30 tons of recycling per month and employed 12 people currently from the disadvantage background. Training and up-skilling were provided to them according to their job specification. In 2014 CoJ commissioned a dirty MRF pilot at the Robinson Deep landfill in Turffontein, Johannesburg, Gauteng under the 'Separation at Source Programme'. The facility was processing 4,970 tons per annum of recyclable materials in 2014. MRFs do not tend to go beyond pilot stage due to low rate of recyclable recovery (Simelane, 2016)

**Fig. 8** Investigation and discussion of MRF consideration in Johannesburg. (Source: Authors own compilation)

of Waste Management of Southern Africa collaborate with private sector, civil society, and academia to promote greater adoption. As with this Figs. 6, 7, and 8 discusses MRF consideration as an adaptation tool for Johannesburg.

## Role of Informal Waste Collectors

Informal waste collectors play an integral role along the waste value chain. Through their activities, waste collectors assist municipalities to collect, separate, and recycle

waste material because they do not have sufficient financial and nonfinancial capacity to provide efficient waste management alone. They operate in similar approaches despite not being recognized or integrated in municipalities' strategies and plans. Due to socio-economic factors, waste collectors continue to operate alongside the municipalities, collecting waste from household to household, designated communal containers and institutions.

In Accra, informal waste collectors continue alongside AMA but are not officially recognized. Known as *Kaya Bola*, they typically port waste from households or markets for a fee, separate the various material, and sell the recyclables for an income. Not being legitimized by local government induces ill-treatment and hostile social environment that keep them operating in an unorganized/informal manner (Oteng-Ababio et al. 2013). Presently, *Kaya Bola* collect and sort 25.0% of total waste generated for income but dispose worthless material in open drains and streams. The only sanitary landfill known as *Knope* has reached its capacity, leaving a few operational dumpsites scattered across the region, namely, *Oblogo* and *Sarbah* (Tuani 2008; Baah and Kharlamova 2018). It is located 37.0 km outside Accra which makes collection and transportation fees very high (The World Bank 2017). The distance and nature of road infrastructure from waste producers to *Knope* or other dumpsites is too far for informal waste pickers, more so for the small transport modes they use, for example, *motorkings* (Accra Metropolitan Assembly 2019).

Presently, informal waste collectors are not recognized as part of Addis Ababa's integrated waste management system. They are seen more as a potential enemy rather than partner (Cheru 2016). Waste pickers collect and sort for valuable recyclables and take them to sell at the *Merkato Market* place, the biggest market in Ethiopia. Various buyers are located there, ranging from independent buyers to factories. In Johannesburg, the lack of landfill space is increasing pressure on the municipality to integrate informal waste collectors along the waste value chain. The *Wastepickers Empowerment Programme* was launched in 2011 with the aim of creating a database of waste collectors in the metropolitan, skills training, assistance to establish cooperatives, provide protective clothing, and assist with fund raising. A pilot program was launched in 2014 and more than 500 waste collectors were registered and benefited from various skills training and personal protective equipment while 55 cooperatives participated in separation at source (Baker et al. 2016). The program can be scaled to other regions in Johannesburg but some lessons from the pilot would need to be considered:

- Consultation with different municipal stakeholders and recycling associations
  - Identifying suitable sites for sorting and storage
  - Establishment of guidelines for waste collectors
- Identification of waste collectors
- Sourcing external funding for training and equipment

There are opportunities to still officially integrate informal waste collectors in the city's strategies and plans. Associations such as the *African Reclaimers Organization* represent collectors' views in this regard. The Department of Environmental Affairs estimates that there are over 62,000 waste collectors in the country, with 40.6% operating as *trolley-pushers* (Mathye 2019).

Overall, various proposals and plans drafted by international organizations such as The World Bank and the African Development Bank stress the need to integrate informal waste pickers into waste management and increase waste transfer stations as strategies for climate adaptation. Their involvement in the waste value chain would boost collection rates and income.

## Nationally Determined Contributions

The Paris Agreement requires every country to produce Nationally Determined Contributions (NCD). These are climate change policies detailing each country's plans towards adaptation and mitigation. Ethiopia, Ghana, and South Africa developed their NCDs. Ethiopia's plan recognizes carbon dioxide (CO<sub>2</sub>), methane (CH<sub>4</sub>), and nitrous oxide (N<sub>2</sub>O) as priority gases that need to be mitigated by 2030. Key sectors producing these gases are agriculture, forestry, transport, industry, as well as waste and cities. In its medium to long term actions, drought relief is an action point where the government will "ensure the uninterrupted availability of water services in urban areas to make them comfortably and productively habitable irrespective of droughts through planning and construction of dams or deep wells, deployment of water saving technologies, and wastewater treatment infrastructure." South Africa's NCDs target agriculture, land use, and waste as targeted sectors for GHG reductions. However, energy is the primary focus.

Lastly, Ghana's adaptation and mitigation commitments strongly feature solid waste management in urban areas while ensuring positive socio-economic derivatives. The country committed to adopting alternative urban solid waste management by 2030. As an adaptation policy action, Ghana committed to building standards for urban waste management through city-wide infrastructure planning. Three mitigation action points include:

- Improve effectiveness of urban solid collection from 70.0% to 90.0% by 2030 and dispose all to an engineered landfill for phase-out methane recovery from 40.0% in 2025 to 65.0% by 2030.
- Scale up 200 institutional biogas in senior high schools and prisons nationwide.
- Double the current waste to compost installed capacity of 180,000 ton/annum by 2030.

There is an opportunity for MRFs to feature as adaptation or mitigation actions depending on each country's resources, more so for Ethiopia and South Africa.

---

## Proposed Recommendations and Conclusion

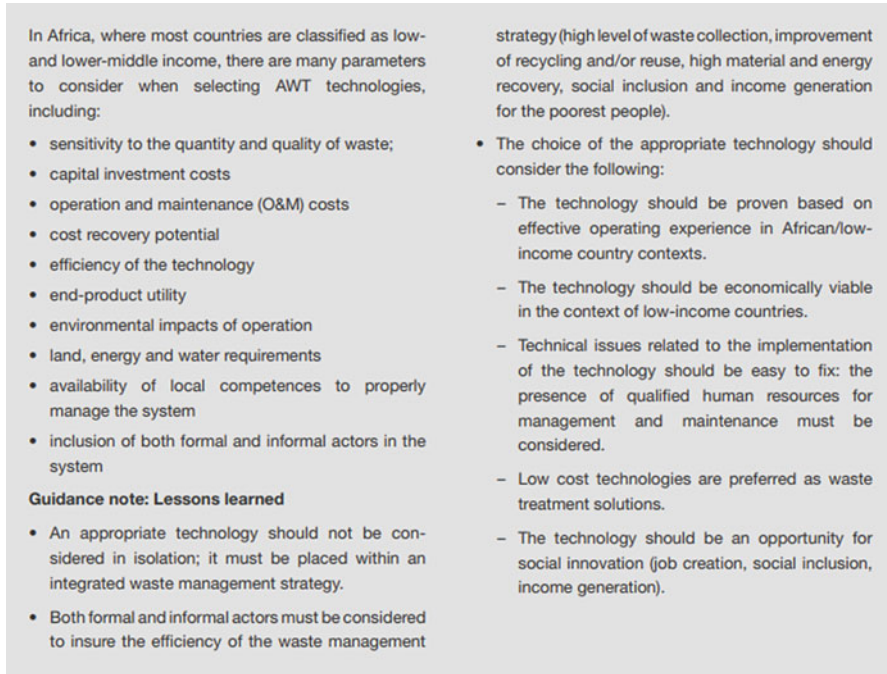
It is evident from current strategies and plans in all three cities that there are opportunities for improved MRF adoption as well as consideration. Urban planners are responsible for designing and developing land, specializing in spatial and land use planning traditionally. Their involvement was seen in activities, decisions,

strategies, and plans for infrastructure development and service provision which are prepared at local government, as seen in Accra's Spatial Development Framework, City of Johannesburg's Integrated Waste Management, and Addis Ababa's Urban Renewal Initiative. As part of the planning process, waste management and/or climate change officials could be included in the process. This was evident in the case of Kenya.

It was also evident that there is a need for the planning process to evolve with the profession and embrace the global push for sustainability and climate change by being more cognizant about waste management and climate change. A central point where all three disciplines converge is land: access to suitable land for disposal, proximity of land to citizens, and possibilities of land inducing negative or positive climate change impacts. In addition, knowledge and implementation of MRFs is generally unknown, with the exception of South Africa, where the Department of Environmental Affairs have taken interest. Climate change adaptation already

**Table 2** MRFs as a climate adaptation strategy

Challenge	Recommendation	Adaptation strategy
Local governments spend at least 50% of total waste budget on waste collection and disposal	Consider exploring small-scale decentralized MRFs to address waste collection, transportation, logistics as well as improve data collection and beneficiation opportunities – climate adaptation strategy	Include more waste management and climate change matters in urban plans Integrate informal waste pickers in city waste management plans to create job in the informal sector
Waste generation and quantities are exacerbated by urbanization and population growth, straining local governments' ability to provide services	Using plans and strategies, planners identify land closer to waste producers and socio-economic activities driving waste generation	Use Green Technology such as GIS and IT to map generation hot spots, determine material flows and data
	Decentralize MRFs on a smaller scale to improve access. Closer to informal communities, shorter distance to travel and potentially more material recovery	Design MRFs guided by technical and social dynamics around identified site
Informal waste pickers are not recognized by local governments despite positive impact in the waste sector	Decentralized small MRFs can assist to streamline waste pickers involvement Create associations or cooperatives for informal waste pickers	Provide training and technologies to women and people in informal communities to enable recycling of waste into other marketable products (e.g., paper briquettes, etc.)
		Develop zones in cities, suburbs and settlements to streamline the collection of waste by informal waste pickers



**Fig. 9** Measures to determine appropriate waste technologies (UNEP 2018)

involves plans and strategies, thus once again there is an opportunity to improve adoption and implementation of MRFs as a land-use and adaptation strategy, and urban planners can aid to drive that inclusion. Table 2 below suggests how including MRFs can be considered as a climate change adaptation measure for the three cities and beyond:

*For MRF Facility Design:* it is important to determine and measure the appropriateness of waste technologies for the continent because of varying drivers, pressures, and parameters (Fig. 9).

Although Africa contributes 4.0% of the world's GHG emissions, with these proposed adaptation strategies, many cities can reduce future emissions and leapfrog into full sustainability despite the current urban and waste related challenges.

## References

- Accra Metropolitan Assembly (2019) Accra Resilience Strategy
- Ali M, Courtenay P (2014) Evaluating the progress of the UK's material recycling facilities: a mini review. *Waste Manag Res* 32:1149–1157. <https://doi.org/10.1177/0734242X14554645>
- Baah D, Kharlamova M (2018) The impact of landfill sites in Accra-Ghana on the surrounding environment. Peoples's Friendship University of Russia, Moscow
- Baker M, Mamela S, Rampete N (2016) Empowerment of waste pickers in the City of Johannesburg, creating an enabling environment for the informal waste sector to participate in municipal

- waste service delivery. In: Proceedings of the 23rd WasteCon Conference 17–21 October 2016, Emperors Palace, Johannesburg, South Africa, p 7
- C40 Cities Climate Leadership Group (2016) New perspectives on climate finance for cities: finance solutions for new and emerging infrastructure approaches to urban climate mitigation and adaptation. Siemens and Citi, London
- Cheru M (2016) Solid waste management in Addis Ababa – a new approach to improving the waste management system. Metropolia University of Applied Sciences, Helsinki
- Cioca L, Ferronato N, Viotti P et al (2018) Risk assessment in a materials recycling facility: perspectives for reducing operational issues. *Resources* 7:85. <https://doi.org/10.3390/resources7040085>
- City of Johannesburg Municipality (2011) City of Johannesburg integrated waste management plan. City of Johannesburg, Johannesburg
- Couth R, Trois C (2012) Sustainable waste management in Africa through CDM projects. *Waste Manag* 32:2115–2125. <https://doi.org/10.1016/j.wasman.2012.02.022>
- Department of Environmental Affairs (2018) South Africa state of waste – a report on the state of environment. First draft. Department of Environmental Affairs, Pretoria
- Department of Environmental Affairs (2019) Design guide for material recovery facilities (MRF) in South Africa. Department of Environmental Affairs, Pretoria
- Field CB, Barros VR, Dokken DJ et al (2014) Climate-resilient pathways: adaptation, mitigation, and sustainable development. In: *Climate change 2014 impacts, adaptation, and vulnerability*. Cambridge University Press, Cambridge, pp 1101–1131
- Friedrich E (2013) An investigation into the emissions of greenhouse gases associated with the disposal of solid waste in the eThekweni municipality. University of KwaZulu-Natal, Durban
- Geda N, Sundaraa R, Seboka B (2011) Challenges and opportunities in municipal solid waste management: the case of Addis Ababa City, Central Ethiopia. *J Hum Ecol* 33:179–190. <https://doi.org/10.1080/09709274.2011.11906358>
- Godfrey N, Zhao X (2016) Financing the urban transition for sustainable development: better finance for better cities, contributing paper for the sustainable infrastructure imperative: financing for better growth and development. New Climate Economy, London/Washington, DC
- Godfrey L, Strydom W, Phukubye R (2016) Integrating the informal sector into the South African waste and recycling economy in the context of extended producer responsibility – CSIR briefing note. CSIR, Pretoria
- Home R (2015) 4-colonial urban planning in Anglophone Africa. In: *Urban planning in sub-Saharan Africa: colonial and post-colonial planning cultures*, 1st edn. Routledge, New York
- Hoomweg D, Bhada-Tata P (2012) *What a Waste: A Global Review of Solid Waste Management*. World Bank, Washington DC
- Hosansky D (2018) Materials recovery facility. Encyclopædia Britannica, Inc.
- Idowu IA, Atherton W, Hashim K et al (2019) An analyses of the status of landfill classification systems in developing countries: sub Saharan Africa landfill experiences. *Waste Manag* 87:761–771. <https://doi.org/10.1016/j.wasman.2019.03.011>
- Kaza S, Yao L, Bhada-Tata P, Van Woerden F (2018) *What a waste 2.0: a global snapshot of solid waste management to 2050*. The World Bank, Washington DC
- Knight Frank (2017) Real estate markets in a continent of growth and opportunity: Africa report 2017/18. Knight Frank LLP, London
- Laffta S, Al-rawi A (2018) Green technologies in sustainable urban planning. *MATEC Web Conf* 162:05029. <https://doi.org/10.1051/mateconf/201816205029>
- Lubida A, Veysipanah M, Pilesjo P, Mansourian A (2019) Land-use planning for sustainable urban development in Africa: a spatial and multi-objective optimization approach. *Geodesy Cartogr* 45:1–15. <https://doi.org/10.3846/gac.2019.6691>
- Lwasa S, Kinuthia-Njenga C (2012) Reappraising Urban Planning and Urban Sustainability in East Africa. In: Polyzos S (ed) *Urban Development*. InTech
- Mathye E (2019) *Changing to a better, greener future*. Department of Environmental Affairs, Pretoria

- Mimura N, Pulwarty RS, Duc DM et al (2014) Chapter 15 – Adaptation planning and implementation. In: *Climate change 2014: impacts, adaptation, and vulnerability. Part A: global and sectoral aspects. Contribution of working group II to the fifth assessment report of the intergovernmental panel on climate change*. Cambridge University Press, Cambridge/New York, pp 869–898
- Mohee R, Simelane T (eds) (2015) *Future directions of municipal solid waste management in Africa*. Africa Institute of South Africa, Pretoria
- Nahman A, Godfrey L (2010) Economic instruments for solid waste management in South Africa: opportunities and constraints. *Resour Conserv Recycl* 54:521–531. <https://doi.org/10.1016/j.resconrec.2009.10.009>
- Nzeadibe TC (2013) Informal waste management in Africa: perspectives and lessons from Nigerian garbage geographies: informal waste management in Africa. *Geogr Compass* 7:729–744. <https://doi.org/10.1111/gec3.12072>
- Oduro-Appiah K, Afful A, Kotey VN, De Vries N (2019) Working with the informal service chain as a locally appropriate strategy for sustainable modernization of municipal solid waste management systems in lower-middle income cities: lessons from Accra, Ghana. *Resources* 8:12. <https://doi.org/10.3390/resources8010012>
- Okeke DC, Nwachukwu MU (2019) Resilient Cities for New Regionalism in Africa. <https://doi.org/10.5281/ZENODO.3459178>
- Oteng-Ababio M, Melara Arguello JE, Gabbay O (2013) Solid waste management in African cities: sorting the facts from the fads in Accra, Ghana. *Habitat Int* 39:96–104. <https://doi.org/10.1016/j.habitatint.2012.10.010>
- Ozoike-Dennis P, Spaling H, Sinclair AJ, Walker HM (2019) SEA, urban plans and solid waste management in Kenya: participation and learning for sustainable cities. *J Environ Assess Pol Manag* 1950018. <https://doi.org/10.1142/S1464333219500182>
- Reda AG, Tripathi NK (2011) *Mainstreaming climate change adaptation in urban planning in Africa*, p 12. Asia Institute of Technology, Chiang Mai
- Revi A, Satterthwaite DE, Aragón-Durand F et al (2014) Chapter 8 – Urban areas. In: *Climate change 2014: impacts, adaptation, and vulnerability. Part a: global and Sectoral aspects. Contribution of working group II to the fifth assessment report of the intergovernmental panel on climate change*. Cambridge University Press, Cambridge/New York, pp 535–612
- Sango T, Kissoon S, Basson L, Munganga G (2014) *Development of the waste economy in the Western Cape: a decision support tool for integrated municipal waste management*. Institute of Waste Management of Southern Africa, Somerset West, Cape Town
- The Economist (2018) African cities pledge zero carbon emissions. <https://country.eiu.com/article.aspx?articleid=536845837&Country=Kenya&topic=Economy>. Accessed 23 Mar 2020
- The World Bank (2017) *Concept project information document integrated safeguards data sheet Greater Accra climate resilient and integrated development project P164330*. The World Bank, Accra
- Trois C (2014) *Current RDI to find alternative solutions – anaerobic digestion of organic waste*. Department of Science and Technology, Durban
- Tuani E (2008) *Managing urbanization and waste disposal in West Africa – feature article*. The International Solid Waste Association, Accra
- UNEP (2018) *Africa waste management outlook*. United Nations Environment Programme, Nairobi
- Vaccari M, Tudor T, Vinti G (2019) Characteristics of leachate from landfills and dumpsites in Asia, Africa and Latin America: an overview. *Waste Management* 95:416–431. <https://doi.org/10.1016/j.wasman.2019.06.032>
- Worldometer (2020) *Population of Africa (2020)*. <https://www.worldometers.info/world-population/africa-population/>. Accessed 30 Apr 2020
- Zafar S (2019) *Introduction to materials recovery facility | EcoMENA*. <https://www.ecomena.org/materials-recovery-facility/>. Accessed 23 Mar 2020
- Zhang C, Xu T, Feng H, Chen S (2019) Greenhouse gas emissions from landfills: a review and bibliometric analysis. *Sustainability* 11:2282. <https://doi.org/10.3390/su11082282>

**Open Access** This chapter is licensed under the terms of the Creative Commons Attribution 4.0 International License (<http://creativecommons.org/licenses/by/4.0/>), which permits use, sharing, adaptation, distribution and reproduction in any medium or format, as long as you give appropriate credit to the original author(s) and the source, provide a link to the Creative Commons license and indicate if changes were made.

The images or other third party material in this chapter are included in the chapter's Creative Commons license, unless indicated otherwise in a credit line to the material. If material is not included in the chapter's Creative Commons license and your intended use is not permitted by statutory regulation or exceeds the permitted use, you will need to obtain permission directly from the copyright holder.







# Farm-Level Impacts of Greenhouse Gas Reductions for the Predominant Production Systems in Northern Nigeria

# 46

Taiwo B. Ayinde, Benjamin Ahmed, and Charles F. Nicholson

## Contents

Introduction .....	876
Overview of Greenhouse Gas Emissions from Agriculture in Nigeria .....	876
Impacts of Climate Change on Agriculture in Nigeria .....	877
Adaptation and Mitigation Strategies for Nigerian Agriculture .....	878
Farm-Level Impacts of GHG Emissions Mitigation Strategies in Sudano-Sahelian and Sudan Savanna Ecological Zones in Northwestern Nigeria .....	879
Current Production Practices as Adaptation or Mitigation Strategies .....	881
Farm-Level Trade-Offs Between Income and GHG Emissions .....	886
Conclusions .....	887
Appendix 1: Detailed Description of the Optimization Model Used to Assess Trade-Offs Between Household Welfare (Income) and Farm-Level GHG Emissions .....	887
The Farm-Level Optimization Model .....	887
References .....	895

## Abstract

This chapter summarizes the sources of greenhouse gas (GHG) emissions from different economic sectors in Nigeria and emphasizes those arising from agriculture and forestry. The impacts of climate change on agricultural systems in

This chapter was previously published non-open access with exclusive rights reserved by the Publisher. It has been changed retrospectively to open access under a CC BY 4.0 license and the copyright holder is “The Author(s)”. For further details, please see the license information at the end of the chapter.

T. B. Ayinde (✉)

Samaru College of Agriculture, Division of Agricultural Colleges, Ahmadu Bello University (ABU), Zaria, Nigeria

B. Ahmed

Department of Agricultural Economics, ABU, Zaria, Nigeria

C. F. Nicholson

Nijmegen School of Management, Radboud University, Nijmegen, Netherlands

© The Author(s) 2021

W. Leal Filho et al. (eds.), *African Handbook of Climate Change Adaptation*,  
[https://doi.org/10.1007/978-3-030-45106-6\\_4](https://doi.org/10.1007/978-3-030-45106-6_4)

875

Nigeria are likely to be large, motivating the need for additional knowledge to assess current practices and formulate appropriate modifications for both mitigation and adaptation. Some current farming practices are believed to be adaptive, but further study would provide better assessments. We also analyzed the trade-offs between household income and GHG emissions at two contrasting sites in northern Nigeria. A farm optimization model maximizing the value of crop, livestock, and tree production activities in a single representative year assessed the potential impacts for GHG reductions of 10% and 25% and the maximum allowable reductions of 26% and 30% on farm activities and income. Emissions reductions of 10% reduced annual household incomes by less than 5% but required substantive changes, especially in livestock owned. Maximum possible GHG emissions reductions (while still meeting minimum household consumption needs) would require marked changes in production pattern and would lower household incomes by 22–44%. We did not assess effects over longer periods, where the role of livestock as a key asset may imply additional negative impacts. Productivity-enhancing technologies that would simultaneously reduce GHG emissions and increase incomes are needed for smallholder farms to play a larger role in climate change mitigation without the burden of reduced incomes and greater risk. This suggests the need for programmatic and policy actions both by national agricultural research systems and the Consultative Group for International Agricultural Research (CGIAR).

---

**Keywords**

Climate change · Agriculture · Nigeria

---

**Introduction**

Agriculture is the major employer of labor in Nigeria (Hansen et al. 2017) for over 70% of the estimated 200 million inhabitants (United Nations Department of Economic and Social Affairs: Population Division 2020). Almost 80% of over 70 million hectares of Nigerian land areas are under rainfed agricultural production that translates to about 40% of national Gross Domestic Product (GDP) (World Bank 2020). Agriculture is also a major contributor to greenhouse gas (GHG) emissions, as described below.

---

**Overview of Greenhouse Gas Emissions from Agriculture in Nigeria**

Agriculture was the largest of the four major sectors that contributed to Nigeria's GHG emissions in 2015. Agriculture, Forestry, and Other Land Use (AFOLU) accounted for two-thirds of total net national emissions of Teratonnes (Tt) CO<sub>2</sub> equivalent (CO<sub>2</sub>-eq). The AFOLU sector includes emissions from land use,

livestock, and removals from harvested wood products. Land use accounted for an estimated 421 Tt CO<sub>2</sub>-eq, or about 90% of emissions from AFOLU. One principal source of land-use emissions is methane (CH<sub>4</sub>) and nitrous oxide (N<sub>2</sub>O) from burning of rice, maize, sugarcane, and wheat residue biomass. Other sources include direct and indirect emissions of N<sub>2</sub>O from nitrogen-based synthetic fertilizers used in managed soils, indirect emissions of N<sub>2</sub>O from manure management, and direct CH<sub>4</sub> emissions from rice cultivation. For livestock, enteric fermentation and manure management for cattle, sheep, and goats contributed 29 Tt CO<sub>2</sub>-eq, with the remaining amounts from camels, mules, swine, and horses. Enteric fermentation was 90% of total livestock-related emissions, with the remainder from paddock, range, and pasture and solid storage systems of manure management. N<sub>2</sub>O and methane CH<sub>4</sub> were the most important GHG from manure management.

Total GHG emissions continue to increase. In 2019, the United States Aid for International Development (USAID) reported a 25% increase of 98 Mt. CO<sub>2</sub>-eq in the country's overall GHG emissions from 1990 to 2014. The average annual change in total emissions was 1% and was mainly from the land-use change and forestry (LUCF) sector. Similarly, a trend assessment from the period 2000 to 2015 showed that AFOLU remained the highest emitter of GHG throughout the years under review (Federal Republic of Nigeria 2018). Emission from land-use category, forest land remaining forest land remained the principal source, and it increased by 25% during the period, whereas removals through HWPs declined by 28%. There was an estimated 37% increase in emissions from rice cultivation, livestock production, manure management, and nitrogen-based synthetic fertilizers in managed soils over the entire period. The increase was attributed to the increase in livestock populations and more utilization of nitrogen-based synthetic fertilizers in managed soils as well as forest biomass loss. Thus, Nigeria's emissions are projected to grow to around 900 million tons per year in 2030, which translates to around 3.4 tons per person (Change Climate Response Policy 2015).

## Impacts of Climate Change on Agriculture in Nigeria

Changes in climate, in particular, the frequency or severity of extreme events, are likely to have serious implications for rainfed agricultural production. Given the diversified socioeconomic conditions of agriculture in Nigeria, climate change could affect crop yields, disease patterns, and compound ecological disasters that include quelea bird's invasion, floods, and drought (Ajetomobi et al. 2015). However, the impacts are likely to vary by region. A vulnerability analysis conducted in 2014 by Nigerian's Federal Ministry of Environment indicated that states in the north experience higher degrees of vulnerability to climate change than those in the south (Haider 2019).

Many crops are sensitive to the modest changes in rainfall and temperature (Haider 2019). For example, the annual mean temperature needed for photosynthesis and growth is about 29 °C for maize and soybean. Currently, mean annual temperatures ranges from 30 °C to 34 °C. A mean annual temperature of 33 °C is desirable

for cotton, and temperature above this threshold can be harmful to plant development (Ajetomobi et al. 2015). The combination of increasing temperature and lower rainfall has hastened desert encroachment, with loss of the wetlands, and rapid reductions in the amount of surface water, flora, and fauna resources on land. Kebbi and Jigawa states observed 5–10% reductions in millet yields due to *Quelea* bird invasion, in addition to drought in Katsina, whereas Sokoto, Zamfara, Kaduna, and Kano states reported between 10% and 25% loss in groundnut yield from heavy floods (National Agricultural Extension and Research Liaison Services (NAERLS) & Planning Research and Statistic Department (PRSD), 2012). Rainfall intensity and distribution have been altered from the usual 500–1000 mm per year. Flooding in 2012 resulted in 363 deaths, massive economic loss, and the displacement of more than 3.8 million people. The total value of destroyed physical and durable assets was reported to be 1.48 trillion (US\$9.5 billion) or about 2% of the rebased GDP of US\$510 billion (Change Climate Response Policy 2015).

Under the business-as-usual scenario of the Change Climate Response Policy (2015), Nigerian agricultural productivity could decline by up to 50% by 2080, with reductions in GDP as large as 4.5% even by 2050. Consequently, in the absence of mitigating measures, there would be steady depletion of vegetation and grazing resources in affected regions. This could also prompt massive emigration and resettlement of people to areas less threatened by desertification. Subsequently, exacerbating communal clashes among herdsmen and farmers and inter-ethnic clashes (Haider 2019).

## Adaptation and Mitigation Strategies for Nigerian Agriculture

Climate change mitigation is the improvement of agricultural production practices to reduce GHG emission, while adaptation involves the uptake of agricultural practices to be more suitable for a modified climate in a particular location (IPCC 2007). Nigeria is now implementing the reduction of emissions due to deforestation and forest degradation (REDD) (USAID 2019), through the national community-based forest resources management program. Other mitigations and adaptation strategies include the adoption of climate-adapted crops (e.g., drought-tolerant and early maturing varieties of crops) and in the livestock sector, improved feed, pasture, ranch, and paddock management systems (Change Climate Response Policy 2015). Programs are also being implemented to reduce the volume of irrigation water, while making more effective use of rainwater and groundwater. Other efforts are directed at providing early-warning seasonal climate forecasts to facilitate adaptation in a given growing season.

However, such adaptation and mitigation strategies are location- and context-specific and are described as autonomous or opportunist adaptation (Haider 2019). Planned adaptation strategies require additional knowledge about appropriate levels of inputs, tillage practices, and assessment of the future environmental conditions (e.g., rainfall, temperature, and relative humidity). Research to assess and implement actions for both adaptation and mitigation. Simulation modeling can support

assessment of adaptation strategies, particularly when experimental data are limiting and future environmental conditions uncertain (Nicholson et al. 2011; Kopainsky and Nicholson 2015). Consistent with the ongoing need for site-specific quantitative studies, the remainder of this chapter describes the use of modeling to assess the impacts of potential mitigation strategies on smallholder farming systems in the Northwestern area of Nigeria (Ayinde 2019).

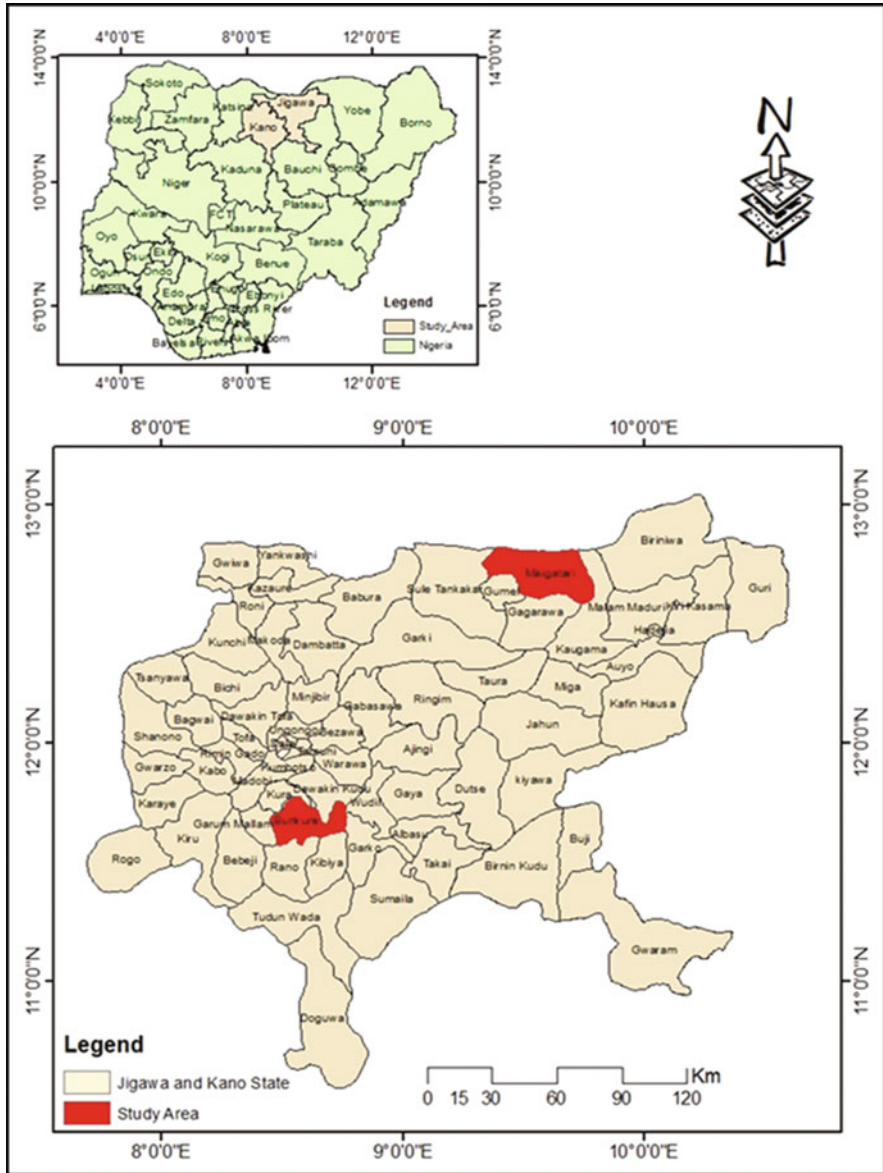
---

## **Farm-Level Impacts of GHG Emissions Mitigation Strategies in Sudano-Sahelian and Sudan Savanna Ecological Zones in Northwestern Nigeria**

An important question concerns the trade-offs among agricultural production, household incomes, and environmental impacts. To date, there are few studies that examine what actions would be required to reduce GHG emissions from smallholder agriculture production systems, and to understand the implications for household well-being. Northwestern Nigeria provides a conducive context for quantitative assessment of farm-level GHG mitigation strategies because it is a highly degraded region with higher degrees of vulnerability to climate change (Haider 2019). Within this region, differences in agro-ecology and production systems necessitate separate assessment of GHG-reduction strategies. Ayinde (2019) thus explored the production practices at two sites, the Bunkure (Sudan Savanna ecology) and Maigateri (Sudano-Sahelian ecology) local government areas (LGAs) located in Kano and Jigawa States, respectively (Fig. 1). The objective of the analysis was to describe predominant farming systems and discuss the extent to which they are consistent with either adaptation or mitigation strategies, and to evaluate quantitatively the impacts on agricultural production and potential trade-offs between household revenue and GHG emissions.

Kano and Jigawa differ in multiple respects, which facilitates a comparative analysis of mitigation strategies at the farm level. Kano is the most-extensively irrigated state in the country for the cultivation of rice, sugarcane, and vegetables, which are important emitters of GHG (IPCC 2013; Dunkelberg et al. 2014). Jigawa is characterized by shorter rainfall duration that does not support irrigated farming but sustains hardier shrubs and trees. In the LGAs of both states, however, mixed farming of grain and legume crops, trees, and livestock keeping are practiced.

Ayinde (2019) used participatory rural appraisal (PRA) and key informant interviews to characterize existing production systems at both study sites. Data were collected on the economic and environmental performance of the predominant production systems, land preparation, retaining of trees on crop field, use of tree branches and stem for firewood, use of crop residue as mulch, modified planting dates, use of early maturing crop variety, and agrosilvopastoral system. Emphasis were on trees that could serve multiple purposes of dry season feed, enriching soil Nitrogen, increasing protein and energy content in fodder while mitigating GHG emissions. This information was necessary to assess whether the production practices employed aligned with either a mitigation or adaptation strategy. The key



**Fig. 1** Locations of the study sites Maigateri in Jigawa State and Bunkure in Kano State

informant interviews provided data of estimates of household-level expenditures on tree, crop, and livestock activities (See the assumed structure of inputs and outputs in the tree-crop-livestock production optimization model Appendix Table A1), the cost of animal draught, and the cost of manure applied. The description of the key specific

inputs used in the current production practices were necessary to estimate the GHGs emissions (CH<sub>4</sub>, N<sub>2</sub>O, CO<sub>2</sub>, and non-CO<sub>2</sub>) in Appendix Tables A2.1 and A2.2.

The emission factors (EF) used to estimate GHG emissions to specific farm activities were obtained from IPCC Tier 1 default equations as well as methods from Standard Assessment of Mitigation Potentials and Livelihoods in Smallholder System (SAMPLES; [www.samples.ccafs.cgiar.org](http://www.samples.ccafs.cgiar.org)) that corresponds to the predominant production systems in the study region. Data on dry matter (DM), metabolizable energy (ME), and crude protein (CP) that corresponded to the tree and crop yield levels were obtained from secondary sources such as feed composition tables or journal articles and grey literature including Feedipedia; FAO source: (<http://www.fao.org/ag/againfo/themes/documents/PUB6/P620.htm>); and (Dupriez and De Leener 1998).

To assess the potential impacts on agricultural production patterns and full household income scenarios evaluated a baseline (current practices and emission levels) and required GHG reductions of 10%, 25%, and the maximum reductions consistent with meeting assumed household consumption needs (26% and 30% reductions compared to the baseline). See the detailed description of the optimization model used to assess trade-offs between household welfare (income) and farm-level GHG emissions in Appendix 1.

## Current Production Practices as Adaptation or Mitigation Strategies

A key finding was that farmers were aware of the multiple uses and economic value of trees for wood, food, fuel, fodder, soil protection, and soil reclamation (Table 1),

**Table 1** Tree and crop (cereal and legume) production practices reported by households in Bunkure and Maigateri

Crop type and production practice	Bunkure		Maigateri	
	N = 50		N = 55	
	Frequency	Percentage	Frequency	Percentage
Trees				
Retained trees on crop field	50	100	55	100
Firewood	19	38	11	20
Cereal				
Predominant cereal grown	26	52	29	53
Use of improved sorghum varieties	11	22	16	29
Construction	13	26	14	25
Fuel	11	22	11	20
Legume				
Predominant legume grown	30	60	29	53
Sell	45	90	42	76
Fodder to own livestock	4	8	10	18
Soil amendment	1	2	3	6

similar to previous studies (Change Climate Response Policy 2015; UN-REDD Programme 2015). Consequently, not all trees were lopped on crop fields. For instance, 30% and 44% of farmers in Bunkure and Maigateri LGAs, respectively, predominantly allowed their Neem (*Azadirachta indica*) trees to remain on the crop fields validating the finding of (Bayala et al. 2011). About 36% (Bunkure) and 42% (Maigateri) of farmers sowed some selected trees that are used mainly as live fences around their farms with 38% of its biomass mostly used as fuel in Bunkure LGA and 31% as manure in Maigateri LGA.

Furthermore, of all the trees allowed to remain on the farm, none met the criteria for the study (i.e., dry season feed, enriching soil nitrogen, increasing protein and energy content in fodder while mitigating GHG emissions like Locust-beans (*Parkia biglobosa*), Camel's foot/*Kalgo* (*Piliostigma reticulatum*) and are distinctively the most popular leguminous tree owned by 10% in Bunkure LGA and 24% of farmers in Maigateri LGA. Personal conversation with staff members of the outstation office of Forestry Research Institute of Nigeria (FRIN), in Samaru (Zaria, Kaduna State) revealed that Locust-beans/*Dorowa* (*Parkia biglobosa*), *Kalgo* (*Piliostigma reticulatum*), and *Gawo* (*Acacia albida*) trees were generally not planted because their seedlings or seeds were undomesticated thus, virtually unavailable. It is further compounded by the long period of growth (Bayala et al. 2014). However, efforts of FRIN were said to be underway to ensure the availability of Locust-beans (*Parkia biglobosa*) seeds or seedlings for propagation with growth period under 7 years as against the natural one of between 12 to 15 years.

Sorghum was the predominant cereal grown by over 50% of farmers in the two study locations. Most farmers in both LGAs (50% and 53%), reported that their sorghum residues comprised an adaptation plan for dry season supplementary feed/feed reserve for their ruminant livestock. About 60% of farmers in Bunkure LGA cultivated Soybean while, 53% in Maigateri LGA cultivated groundnut as their predominant legumes. Despite the numerous benefits of soybean and groundnut residue biomass for nitrogen fixation and GHG mitigation when used for soil amendments as an adaptation strategy, majority of farmers in Bunkure and Maigateri LGA sold their crop residue biomass. The implication of these practices are consequential as it may lead to more emissions of CH<sub>4</sub>, CO<sub>2</sub>, and N<sub>2</sub>O, which may result in accelerated nutrient depletion from burning of bushes and crop residues, leaching, and acid rains (NH<sub>3</sub> volatilization) from the application of inorganic fertilizer (IPCC 2013). Once there is accelerated nutrient depletion, there may be gross production declines.

Farmers in the study zones claimed that unplanned consumption by free ranging livestock reduced the incentives for use of crop residues soil amendments. Therefore, except by-laws and community conventions are in place to restrict free grazing, the use of biomass for soil amendment faces constraints for the poorly sourced farmers of Bunkure and Maigateri LGAs, who would rather sell their crop residue than have them consumed by free-ranging livestock.

Adaptation strategies such as change in sowing dates and use of early maturing varieties were adopted by most farmers in the regions. However, such practices in addition to mulching are merely coping/autonomous or opportunist strategies by



**Table 2** Livestock production reported by households in Bunkure and Maigateri

Livestock characteristic	Bunkure		Maigateri	
	N = 50		N = 55	
	Frequency	Percentage	Frequency	Percentage
Livestock				
Predominant breed of sheep	25	50	30	55
Predominant breed of goat	32	64	40	73
Seasonal tethering/cut and carry	19	38	15	37
Intensive/peri-urban ruminant husbandry	1	2	1	2

farmers as described by Haider (Haider 2019). More is required of these practices in terms of investment in infrastructure, subsidies, research, innovation, and tax regimes to attain planned adaptation strategies.

Livestock production is a major activity among smallholder farmers in Bunkure and Maigateri, LGAs. During the focus group discussions, farmers reported that most crops were sold immediately after harvest. Revenues from crop sales were used to purchase animals, particularly ruminant livestock. The Red Bororo (100%) is the major breed of cow in Maigateri LGA, whereas Sokoto Gudali is reared by 60% of farmers in Bunkure LGA (Table 2). A cow, 5 sheep, and 6 goats are the average herd size of cattle, sheep (Uda), and goats (Red Sokoto or Maradi Breed) owned per household in Bunkure. Households in Maigateri owned an average of 2 cows, 12 sheep, and 14 goats. Livestock is fattened for up to 7 months and then sold. Part of the revenues generated from livestock sales is used to acquire farm inputs for another planting season.

Farmers in Bunkure and Maigateri LGAs believe a successful adaptation strategy is “compound dairy” (a traditional system of milking in which animals are confined to the compound rather than allowed to graze). The cows supply the family with fluid milk for consumption and any excess above household needs is sold or processed into other dairy products. In this system, dairy animals were either tethered and fed on traditional cut and carry using cereal/legume crop residue or allowed to graze freely around the compounds in the day and confined in the night in the wet season. It was the most widely practiced adaptation mechanism among all households as confirmed by 98% of households.

A key issue with the compound dairy is whether it is possible to achieve higher productivity per animal from increased grain cultivation, without increasing GHG emissions. The use of concentrates or cultivation of pastures for supplementary feeding of indigenous Zebu and Ndama breeds of cattle is uneconomical and of doubtful feasibility (Ayantunde et al. 2007). Because, there is no strong evidence of economies of scale, due to under-utilized family labor and the ability of ruminants to exploit low-value roughage, including that gathered or grazed from public lands (Mcdermott et al. 2010). Moreover, higher-productivity breeds cannot generally replace indigenous Zebu and Ndama breeds of cattle, as these breeds are not suitable for North-western Nigeria (Ayantunde et al. 2011). Although studies confirm

**Table 3** Optimal farm-level tree-crop-livestock production decisions for the three scenarios in Bunkure and Maigateri LGA

Outcome or activity	Bunkure				Maigateri				
	Units	Baseline	Difference with – 10% GHG reduction	Difference with – 25% GHG reduction	Maximum GHG reduction	Baseline	Difference with – 10% GHG reduction	Difference with – 25% GHG reduction	Maximum GHG reduction
<b>Tree</b>									
Locust beans/ Carmel's foot	Ha	<b>2</b>	0	–0	–1	<b>2</b>	0	0	0
<b>Crop</b>									
Sorghum	Ha	<b>1</b>	0	0	0	<b>1</b>	0	0	0
Soybean/ groundnut	Ha	<b>0</b>	0	0	0	<b>3</b>	0	–0	–2
<b>Animals</b>									
Cow	Head	<b>0</b>	0	0	0	<b>1</b>	–0	–1	–1
Sheep	Head	<b>10</b>	–5	–5	–5	<b>5</b>	–1	–1	–1
Goats	Head	<b>5</b>	0	0	0	<b>4</b>	0	0	0
<b>GHG emissions per farm</b>	Kg CO <sub>2</sub> eq /yr	<b>2943</b>	2649	2207	2175	<b>3057</b>	2751	2293	2124
<b>Revenues</b>									
Locust beans/ Carmel's foot	000 ₦/ yr	<b>2316</b>	0	–4746	–6754	<b>8606</b>	0	0	0
Sorghum	000 ₦/ yr	<b>8334</b>	0	0	0	<b>7430</b>	0	0	0
Soybean/ groundnut	000 ₦/ yr	<b>3004</b>	0	0	0	<b>1105</b>	0	–1606	–6051

Cow	000 ₦/ yr	7226	7723	0	0	1983	-2937	-1145	-1145
Sheep	000 ₦/ yr	2191	-1071	-1061	-1061	7385	-1955	-1955	-1955
Goats	000 ₦/ yr	1230	0	0	0	6165	0	0	0
Cost of purchased inputs									
Locust beans/ Carmel's foot	000 ₦/ yr	1722	0	-3529	-5022	6002	0	0	0
Sorghum	000 ₦/ yr	3493	0	0	0	1976	0	0	0
Soybean/ groundnut	000 ₦/ yr	218	0	0	0	2499	0	-3633	-1369

improved feeding and manual management system as mitigation strategies that reduce total emissions of CO<sub>2</sub>, CH<sub>4</sub>, and N<sub>2</sub>O in the livestock sector, the extent to which this is possible requires further study to determine appropriate strategies for location-specific reductions.

## **Farm-Level Trade-Offs Between Income and GHG Emissions**

GHG reductions of up to 26% were possible with assumed minimum levels of household consumption in Bunkure LGA (Table 3), but reduction would require reductions in farm-level revenue of more than 20%. Reductions were achieved essentially from reductions in the sales of sheep meat, locust bean pod, branch, and trunk in addition to a reduction in the sales of sheep manure (Appendix Table A3). Maximum possible decreases in GHG emissions require reduction of livestock to minimum assumed household consumption levels and a reduction in profitable locust bean production through reduction in land area by 29%. Similarly, quantities of purchased input used for locust bean production, reduced significantly for urea, seeds, and agricultural pesticides. Below 26%, the model could not attain feasible adaptation strategies because it could not meet household requirements as assumed.

In Maigateri LGA, GHG reductions of up to 30.5% could be attained with minimum levels of household consumption. However, such reductions in GHG emissions would require reductions in farm-level revenue of about 44%. Reductions in GHG emissions were accomplished primarily decreases in groundnut, cow, and sheep production and from up 100% reduction in the sales in the livestock component as well as 55.7% reduction in sales of groundnut grain in the crop component. Maximum GHG emissions reduction implied decreases in groundnut production, in addition to the reduction of livestock to minimum assumed household consumption levels.

By implication, the assessment of trade-offs that indicate potential pathways for increased agricultural productivity with fewer negative environmental effects, are usually location- and context-specific, thus difficult to generalize, categorize, and describe in contrasting socio-ecological contexts (e.g., Thornton et al. 2018). Yet, it could be futile to identify win–win production without a framework to generalize them into policy recommendations and developmental actions. The major contribution of this chapter is the establishment of a generic conceptual framework that can be used across farms of different agro-ecological zone. Particularly for comparative assessment and prioritization of policy options, that could be scaled up from local/community or farm level to regional or country levels.

However, better understanding of trade-offs is needed to attain win–win scenario (Steenwerth et al. 2014; Klapwijk et al. 2014; Kanter et al. 2016). More accurate indices and numbers could be achieved with the use of system dynamic model analyses (Serman 1989; Kopainsky and Nicholson 2015), and could be considered as suggestion for further studies.

## Conclusions

This chapter has documented the importance of agriculture and land use in the generation of GHG emissions in Nigeria, and the need for both adaptation and mitigation strategies in smallholder agriculture. The farm-level impacts provide information needed to formulate appropriate mitigation and adaptation strategies for going forward in climate-smart agriculture. A key finding from the farm-level analysis is that revenue generated decreases with GHG emissions mitigation and adaptation. Maximum possible GHG emissions reductions (while still meeting minimum household consumption needs) would require marked changes in production pattern and would lower household incomes. There appear to be no win-win adaptation strategies with current production practices and technologies that both increase revenue generation and reduce GHG. Productivity-enhancing technologies that would simultaneously reduce GHG emissions and increase revenue are needed for smallholder farms to play meaningful climate change mitigation and adaptation strategies in Nigeria without the burden of reduced incomes and greater risk. We also did not assess effects over longer periods, where the role of livestock as a key asset may imply additional negative impacts. This suggests the need for programmatic and policy actions to be taken by both national agricultural research systems and the Consultative Group for International Agricultural Research (CGIAR) to promote climate-smart agriculture in Nigeria.

**Acknowledgments** This study was conducted with the financial support of the Standard Assessment of Mitigation Potentials in Smallholder Farmers Livelihood System (SAMPLES), a CGIAR Research Program on Climate Change, Agriculture, and Food Security (CCAFS).

---

## Appendix 1: Detailed Description of the Optimization Model Used to Assess Trade-Offs Between Household Welfare (Income) and Farm-Level GHG Emissions

### The Farm-Level Optimization Model

The farm model (Eq. 1) assessed the potential trade-offs between GHG reductions and farm revenue with the aim to identify the impacts of possible mitigation strategies and facilitate future analysis of potential adaptation opportunities through production practices that result in both reduced emissions and increased farm incomes.

The objective function  $Z$  maximizes net household full revenue generated, given by:

$$Z = - \sum_{m=1}^{12} W_m \cdot X_m^L - \sum_{i=1, j=1}^{i=4, j=6} P_i \cdot X_{ij}^I + \sum_{j, p=1}^{20} C_{jp} \cdot X_{jp}^P \quad (1)$$

where

$W_m$  = Wage paid per hour of hired labor in month  $m$

$X_m^L$  = Hours of labor hired by the household in month  $m$

$X_{ij}^I$  = Purchased input  $i$  for tree or crop production activity  $j$

$P_i$  = Price of purchased input  $i$  per unit

$C_{jp}$  = Unit value per kg for subproduct  $p$  of tree, crop, or livestock activity  $j$

$X_{jp}^P$  = Production of subproduct  $p$  of tree, crop, or livestock activity  $j$

The objective function maximizes the total value of products derived from activities  $j = 1$  to 6 locust bean and camel's foot in Bunkure and Maigateri, respectively. Represented as tree species. Branches and trunk of the Locust bean and Camel's foot trees can be used to meet household firewood requirements. Sorghum, legumes species are predominantly soybean in Bunkure and groundnut in Maigateri. While livestock includes cows, goats, and sheep production. "Full income" is specified as sum of product sold by the household. In addition to the opportunity cost of product consumed by the household less the costs of hired labor and the value of purchased inputs  $i = 1$  to 4 that include fertilizer (NPK mix and urea), agricultural chemicals, manure, and seed for grains and legumes. Each of the products has subproducts that are either sold to generate revenue or used as internally generated inputs (Table A3) or used as internally generated inputs on the farm (Table A1). A total of 20 ( $j, p$ ) combinations of activities and subproducts are represented.

Land is one of the basic farm household resource constraint and the predominant land type (upland) used for rainfed production is modeled with the following equation:

$$L \geq \sum_{j=1}^6 L \cdot X_j^P \quad (2)$$

which shows that the total land available to the household,  $L$ , must be greater than or equal to total land used for annualized production activities  $j, X_j^P$ . Thus, for model simplification, the agricultural activities were assumed to be yearly. Land rental is excluded to avoid unbounded solutions.

A labor constraint signifies that the sum of household labor  $H_m$  and or hired labor,  $X_m^L$  available must exceed or meet total labor required for agricultural production activities,  $X_j^P$

$$H_m + X_m^L \geq \sum_{j=1}^7 a_{jm}^L \cdot X_j^P \quad (3)$$

The purchase of inputs used for production activities is given by the product of the activity  $X_j^P$  and the fixed coefficient  $a_{ij}^I$

$$a_{ij}^I \cdot X_j^P \leq X_{ij}^I \quad (4)$$

Inputs produced on-farm and used for other production include tree fodder, crop residue biomass, manure, and milk. Tree fodder and crop residues are used as animal feed or soil amendment. Tree components were partitioned using formula adapted from Powell et al. (1995) and Bayala et al. (2014). Residue obtained as by-product from sorghum production were derived, using formula for harvest index adapted from Powell et al. (1995). Similarly, manure is used as fertilizer, while milk is used to feed young livestock. Formula for calculating manure production was in line with Powell et al. (1995) and Ayantunde et al. (2000). The relationships are represented by this equation:

$$\sum_{j'} a_{j'j}^R \cdot X_{j'}^P \geq \sum_j a_{j,j}^R \cdot X_j^P \tag{5}$$

The equation above requires that the amount available from the sum of production of  $j'$  sources must be greater than or equal to the sum of farm-generated resource used. The model includes constraints for animal nutrient requirements: dry matter (DM, kg/day), crude protein (CP, g/day) and metabolizable energy (ME, in mega joules, MJ) FAO, [http://www.fao.org/ag/againfo/themes/documents/PUB6/P6\\_20.htm](http://www.fao.org/ag/againfo/themes/documents/PUB6/P6_20.htm): that states the recommended daily ME for maintenance of sheep and goat is 5.1 and for cow producing less than 5 lit per day is 46 ME MJ/day. Recommended daily CP and DM requirement is 3% animal body weight, with average weight of 350 kg cow, 20 kg sheep, and 20 kg goat translating to 400, 32, and 32 g CP/day, respectively

The constraint in equation 6 requires the diet fed to livestock must be less than or equal to the nutritional requirements for metabolizable energy (ME), crude protein (CP), and dry matter (DM) is represent thus:

$$\sum_{j',p} a_{j',p,n}^{NS} \cdot X_{j',p}^{USE} \forall j \in \text{animal}, (j',p) \in \text{feeds} \geq a_{j,n}^{NR} \cdot X_j^P \tag{6}$$

which indicates that the sum of the  $(j,p)$  the product of feeds allocated to animals of type  $j$ ,  $X_{j',p}^{USE}$  and the nutrient content of those feeds,  $a_{j',p,n}^{NS}$ , must exceed the required  $n = 3$  nutrients for animals of type  $j$ ,  $a_{j,n}^{NR} \cdot X_j^P$

Products  $(j, p)$  allocated to household use  $X_{j,p}^{HH}$ , also must meet minimum household consumption requirement  $HHR_{j, p}$ , as follows:

$$HHR_{j,p} \leq X_{j,p}^{HH} \tag{7}$$

A balance constraint ensures that uses of products  $(j, p)$  for household consumption, sales, or use in production is less than or equal to the total sources supplied:

$$X_{j,p}^{HH} + X_{j,p}^{SALES} + \sum_{j'} a_{j'j}^R \cdot X_{j'}^P \leq a_{j,p}^{YLD} \cdot X_{j,p}^P \tag{8}$$

**Table A1** Assumed structure of inputs and outputs in the tree-crop livestock production optimization model

Activity (j)	Inputs	Output	Saleable output	Consumed output
Locust bean and Camel's foot trees	Seeds, urea fertilizer, pesticides, labor, manure	Fodder, pod, pod valve, bran, branches, and trunk	Fodder, pod, pod-valve, bran	Pod, branches, and trunk
Sorghum	Seeds, urea, and NPK fertilizer, pesticides, labor, manure	Grain, fodder, bran	Fodder, bran	Grain
Soybean and groundnut	Seeds, urea, and NPK fertilizer, pesticides, labor, manure	Grain, fodder, bran, hull	Grain, fodder, bran, hull	Grain
Cow	Sorghum Stover/straw, Soyhull/groundnut residue biomass	Meat, milk, manure	Meat, milk, manure	Milk
Goat	Sorghum Stover/straw, Soyhull/groundnut residue biomass	Meat, manure	Meat, manure	Meat
Sheep	Sorghum Stover/straw, Soyhull/ groundnut residue biomass	Meat, manure	Meat, manure	Meat

An additional constraint requires that the sum of GHG emissions  $a_j^{GHG}X_j^P$  generated in the predominant farm practices must equal total GHG emissions per farm:

$$\sum_{j=1}^6 a_j^{GHG}X_j^P = GHG \quad (9)$$

which is used in the specification of alternative scenarios about required GHG emissions reductions per farm. For simplicity,  $a_j^{GHG}$  does not include the effects of emissions from application of lime, pre-farm operations during storage, and transportation as well as all mechanized farm operations, as these are minimal in this farming system.

The Tier 1 default methods and emission-factors (EFs) from the 2006 version of the guidelines that considered management practices with soils containing N inputs (Table A2.1) was employed. The default Carbon (C) produced is less than the estimated C harvested, and dead wood and litter stocks present in the predominant production system are at equilibrium and specified as zero. The Tier 1 default EF of 0.20 representing 20% for CO (NH<sub>2</sub>)<sub>2</sub> was assumed for calculating annual CO<sub>2</sub> emissions from urea application in kg C/yr. Amounts of CO<sub>2</sub> equivalents were calculated by multiplying CO<sub>2</sub>-C emissions values obtained by 44/12. Non-CO<sub>2</sub> emissions due to fire were estimated from the product of land area, (hectare), mass of fuel available for combustion, (tons ha<sup>-1</sup>), combustion factor values, and emission



**Table A2.1** Assumed values of GHG emissions related to land use, Bunkure and Maigateri LGAs

Type of emissions	Bunkure			Maigateri		
	Locust bean (kg CO <sub>2</sub> eq/ha/ year)	Sorghum (kg CO <sub>2</sub> eq/ha/ year)	Soybean (kg CO <sub>2</sub> eq/ha/ year)	Camel's foot (kg CO <sub>2</sub> eq/ha/ year)	Sorghum (kg CO <sub>2</sub> eq/ha/ year)	Groundnut (kg CO <sub>2</sub> eq/ha/ year)
Non-CO <sub>2</sub> from burning	127.5	127.5	127.5	127.5	127.5	127.5
Direct N <sub>2</sub> O soils	10.1	142.3	12.3	6.6	146.4	11.4
Indirect N <sub>2</sub> O soils	2.3	21.6	0.0	1.1	25.6	0.0
Urea application	36.7	73.3	0.0	18.3	32.1	18.3

**Table A2.2** Assumed values of GHG emissions related to animal numbers, Bunkure and Maigateri LGAs

Type of emissions	Bunkure			Maigateri		
	Cows (kg CO <sub>2</sub> eq/TLU/ year)	Sheep (kg CO <sub>2</sub> eq/TLU/ year)	Goats (kg CO <sub>2</sub> eq/TLU/ year)	Cows (kg CO <sub>2</sub> eq/TLU/ year)	Sheep (kg CO <sub>2</sub> eq/TLU/ year)	Goats (kg CO <sub>2</sub> eq/TLU/ year)
CH <sub>4</sub> emissions	987.0	172.2	109.6	987.0	172.2	109.6
N <sub>2</sub> O emissions	186.7	20.8	24.4	186.7	20.8	24.4

**Table A3** Optimal farm-level tree-crop-livestock production decisions for the three scenarios in Bunkure and Maigateri LGA

Outcome or activity	Units	Bunkure				Maigateri			
		Baseline	Difference with -10% GHG reduction	Difference with -25% GHG reduction	Maximum GHG reduction	Baseline	Difference with -10% GHG reduction	Difference with -25% GHG reduction	Maximum GHG reduction
<b>Sales of products</b>	Kg/yr								
<b>Tree</b>									
Locust beans/Camel's foot pod		<b>3383</b>	0	-697	-993	<b>1180</b>	0	0	0
Locust beans/Camel's foot fodder		<b>0</b>	0	284	0	<b>0</b>	372	372	0
Locust beans/Camel's foot branch		<b>3045</b>	0	-1073	-1527	<b>0</b>	0	0	0
Locust beans/Camel's foot trunk		<b>1361</b>	0	-2790	-3970	<b>4745</b>	0	0	0
<b>Crop</b>									
Sorghum bran		<b>0</b>	0	66	0	<b>0</b>	31	31	0
Soybean/groundnut grain		<b>0</b>	0	0	0	<b>2601</b>	0	-385	0
Soybean bran/groundnut meal		<b>0</b>	0	3	0	<b>0</b>	13	11	0

(continued)

**Table A3** (continued)

Outcome or activity	Units	Bunkure				Maigateri			
		Baseline	Difference with -10% GHG reduction	Difference with -25% GHG reduction	Maximum GHG reduction	Baseline	Difference with -10% GHG reduction	Difference with -25% GHG reduction	Maximum GHG reduction
Soy/hull/groundnut haulms		<b>1</b>	0	0	0	<b>0</b>	104	804	0
<b>Animals</b>									
Cow meat		<b>43</b>	46	0	0	<b>160</b>	-24	-93	-93
Cow milk		<b>0</b>	146	0	0	<b>187</b>	-48	-187	-187
Cow manure		<b>257</b>	275	0	0	<b>811</b>	-120	-468	-468
Sheep meat		<b>142</b>	-131	-142	-142	<b>36</b>	-36	-36	-36
Sheep manure		<b>983</b>	-481	-521	-521	<b>503</b>	-133	-133	-133
Goat manure		<b>555</b>	0	0	0	<b>432</b>	0	0	0

factor ( $\text{g kg}^{-1}$  dry matter burnt) for various type of burning. The carbon dioxide equivalents ( $\text{CO}_2\text{eq}$ ) factor was set at zero based on the assumption that the conversion of CO and  $\text{NO}_x$  has weak global warming potential.

$\text{N}_2\text{O}$  emissions include volatilization and leaching from manure management system (MMS) and managed soil (MS). Other  $\text{N}_2\text{O}$  losses considered are annual amount of N in crop residues (above and below ground), including N-fixing crops, and from forage/pasture renewal, returned to soils annually, ( $\text{kg N yr}^{-1}$ ). DAP composition for Nitrogen (N) content in 50 kg bag of NPK fertilizer with urea excluded is 0.20 kg N. All emissions were converted to  $\text{N}_2\text{O}$  by multiplying 44/28 with values obtained

In ruminant livestock production, MMS and enteric fermentation result in  $\text{CH}_4$  emissions in (Table A2.2). The EFs for sheep, goat, and mature cow grazing on large areas in developing countries were used. One TLU represents 250 kg live weight; equivalent of 1 camel, 1.43 cattle, 10 sheep/goats according to Ayantunde et al. (2011). All results were converted to carbon-dioxide equivalents ( $\text{CO}_2\text{eq}$ ). In accordance with IPCC, a unit of  $\text{CO}_2$ ,  $\text{CH}_4$ , and  $\text{N}_2\text{O}$  represents 1, 21, and 310 units of  $\text{CO}_2\text{eq}$ , respectively

To implement scenarios requiring farms to reduce GHG emissions from current levels, an additional constraint was developed to ensure GHG emissions generated from the predominant production practice is less than the assumed amount:

$$\sum_{j=1}^6 a_j^{GHG} X_j^P \leq GHGLIM \quad (10)$$

## References

- Ajetomobi J, Olusanya A, Gbadegesin A (2015) AGRODEP working paper 0016 the potential impact of Climate Change on Nigerian agriculture. International Food Policy Research Institute, Washington, DC. <https://doi.org/http://ebrary.ifpri.org/cdm/ref/collection/p15738coll2/130099>
- Ayantunde AA, Fernandez-Rivera S, Hiernaux PHY, van Keulen H, Udo HMJ, Chanono M (2000) Effect of nocturnal grazing and supplementation on diet selection, eating time, forage intake and weight changes of cattle. *Anim Sci* 71:333–340
- Ayantunde AA, Delfosse P, Fernandez-Rivera S, Gerard B, Dan-Gomma A (2007) Supplementation with groundnut haulms for sheep fattening in the West African Sahel. *Trop Anim Health Prod.* <https://doi.org/10.1007/s11250-007-9009-1>
- Ayantunde AA, Leeuw JD, Turner MD, Said M (2011) Challenges of assessing the sustainability of (agro) -pastoral systems. *Livest Sci* 139(1–2):30–43. <https://doi.org/10.1016/j.livsci.2011.03.019>
- Ayinde TB (2019) Economics of optimum tree-crop-livestock intensification and green house gas emissions in smallholder production system in North-western Nigeria. Unpublished Ph.D. thesis at the Department of Agricultural Economics, Ahmadu Bello University, Zaria
- Bayala J, Kalinganire A, Tchoundjeu Z, Sinclair F, Garrity D (2011) Conservation agriculture with trees in the West African Sahel – a review (No. 14). ICRAF, World Agroforestry Centre, Nairobi
- Bayala J, Ky-dembele C, Kalinganire A, Olivier A, Nantoumé H (2014) A review of pasture and fodder production and productivity for small ruminants in the Sahel. World Agro Forestry Center, Bamako. Retrieved from [www.worldagroforestry.org](http://www.worldagroforestry.org)

- Change Climate Response Policy (2015) Nigeria's intended nationally determined contribution 1 summary. Federal Republic of Nigeria
- Dunkelberg E, Finkbeiner M, Hirschl B (2014) ScienceDirect sugarcane ethanol production in Malawi: measures to optimize the carbon footprint and to avoid indirect emissions. *Biomass Bioenergy* 71:37–45. <https://doi.org/10.1016/j.biombioe.2013.10.006>
- Dupriez H, De Leener P (1998) Tree and multistorey agriculture in Africa. Technical Centre for Agricultural and Rural Cooperation(CTA)
- Federal Republic of Nigeria (2018) Federal Republic of Nigeria First Biennial Update Report ( BUR1 ) of the Federal Republic of Nigeria under the United Nations Framework Convention on First Biennial Update Report (BUR1) of the Federal Republic of Nigeria. [https://doi.org/https://unfccc.int/sites/default/files/resource/Nigeria%20BUR1\\_Final%20%282%29.pdf](https://doi.org/https://unfccc.int/sites/default/files/resource/Nigeria%20BUR1_Final%20%282%29.pdf)
- Haider H (2019) Climate change in Nigeria: impacts and responses. UK Department for International Development (DFID), K4D and other government departments
- Hansen JW, Araba D, Hellin J, Goslinga R (2017) A roadmap for evidence-based insurance development for Nigeria's farmers. Wageningen: CGIAR research program on climate change, agriculture and food security (CCAFS). Available online at: [www.ccafs.cgiar.org](http://www.ccafs.cgiar.org)
- Inter-Governmental Panel on Climate Change (IPCC) (2007) In: 4th assessment report. Impacts adaptation and vulnerability. Cambridge
- Inter-Governmental Panel on Climate Change (IPCC) (2013) Summary for policymakers. In: Stocker TF, Qin D, Plattner GK, Tignor MMB, Allen SK, Boschung J, Nauels A, Xia Y, Bex V, Midgley PM (eds) Climate Change 2013: the physical science basis. Cambridge University Press, Cambridge/New York
- Kanter DR, Musumba M, Wood SLR, Palm C, Antle J, Balvanera P et al (2016) Evaluating agricultural trade-offs in the age of sustainable development. *Agric Syst.* (in Press)
- Klapwijk C, van Wijk M, Rosenstock T, van Asten P, Thornton P, Giller K (2014) Analysis of trade-offs in agricultural systems: current status and way forward. *Curr Opin Environ Sustain* 6:110–115
- Kopainsky B, Nicholson FC (2015) System dynamics and sustainable intensification of food systems: complementarities and challenges. In: The 33rd international conference of the system dynamics society, 19–23 July 2015. Cambridge, MA, pp 15–22
- Mcdermott JJ, Staal SJ, Freeman HA, Herrero M, Van De Steeg JA (2010) Sustaining intensification of smallholder livestock systems in the tropics. *Livest Sci* 130:95–109. <https://doi.org/10.1016/j.livsci.2010.02.014>
- National Agricultural Extension and Research Liaison Services (NAERLS), & Planning Research and Statistic Department (PRSD). (2012). In: Agricultural Performance Survey Report of 2012 Wet Season in Nigeria, NAERLS, Ahmadu Bello University. (In: *Agricu*, p. 222.). Zaria, Nigeria: NAERLS Press
- Nicholson CF, Tedeschi LO, Lellis Vieira ACG (2011) The application of system dynamics modelling to enhance profitability and sustainability in Latin American livestock systems. In: Paper presented at the II Simposio Internacional Genómica y Modelación en los Nuevos Escenarios de la Ganadería Bovina Tropical. Palmira
- Powell JM, Fernandez-Rivera S, William TO, Renard C (1995) Livestock and sustainable nutrient cycling in mixed farming Systems of Saharan Africa. In: Powell C, Fernandez-Rivera JM, William S, Renard TO (eds) Proceedings of an international conference, Addis Ababa, p 568
- Steenwerth KL, Hodson AK, Bloom AJ, Carter MR, Cattaneo A, Chartres CJ, . . . , Jackson LE (2014) Climate-smart agriculture global research agenda: scientific basis for action. *Agric Food Sec* 3(1):11
- Sterman JD (1989) Modeling managerial behavior: misperceptions of feedback in a dynamic decision-making experiment. *Manag Sci* 35(3):321–339
- Thornton PK, Whitbread A, Baedeker T, Cairns J, Claessens L, Baethgen W et al (2018) A framework for priority-setting in climate smart agriculture research. *Agric Syst* 167(October):161–175. <https://doi.org/10.1016/j.agsy.2018.09.009>
- United Nations Department of Economic and Social Affairs: Population Division (2020) Nigeria population clock (live). <https://doi.org/https://countrymeters.info/en/Nigeria>

- United States Aid for International Development (USAID) (2019) Greenhouse gas emissions in Nigeria
- UN-REDD Programme (2015) Draft report National Programme Annual Report Federal Republic of Nigeria. UN-REDD programme
- World Bank (2020) Nigeria – agricultural land (hectares). <https://doi.org/https://tradingeconomics.com/nigeria/agricultural-land-hectares-wb-data.html>

**Open Access** This chapter is licensed under the terms of the Creative Commons Attribution 4.0 International License (<http://creativecommons.org/licenses/by/4.0/>), which permits use, sharing, adaptation, distribution and reproduction in any medium or format, as long as you give appropriate credit to the original author(s) and the source, provide a link to the Creative Commons license and indicate if changes were made.

The images or other third party material in this chapter are included in the chapter's Creative Commons license, unless indicated otherwise in a credit line to the material. If material is not included in the chapter's Creative Commons license and your intended use is not permitted by statutory regulation or exceeds the permitted use, you will need to obtain permission directly from the copyright holder.





# GIS-Based Assessment of Solar Energy Harvesting Sites and Electricity Generation Potential in Zambia

# 47

Mabvuto Mwanza and Koray Ulgen

## Contents

Introduction .....	900
Geographical Description .....	903
Solar Photovoltaic Power Plant Siting Considerations .....	904
Environmental and Social Issues .....	904
Restricting Issues .....	904
Potential Site Identification and Mapping .....	907
Solar PV Potential Site Identification and Mapping .....	907
Available Land Area .....	911
Electricity Generation Potential .....	912
Potential Site and Electricity Generation Potential .....	921
Solar PV Potential Sites and Mapping .....	921
Available Suitable Land Area .....	921
Electrical Power and Electricity Generation Potential .....	927
Conclusion .....	941
References .....	943

## Abstract

Land and environment are some of limited nature resource for any particular country and requires best use. Therefore, for sustainable energy generation it is often important to maximize land use and avoid or minimize environmental and social impact when selecting the potential locations for solar energy harvesting. This chapter presents an approach for identifying and determining the potential sites and available land areas for solar energy harvesting. Hence, the restricting and enhancing parameters that influence sites selection based on international

---

M. Mwanza (✉)

Department of Electrical and Electronic Engineering, School of Engineering, University of Zambia, Lusaka, Zambia

K. Ulgen

Ege University, Solar Energy Institute, Bornova/Izmir, Turkey

e-mail: [koray.ulgen@ege.edu.tr](mailto:koray.ulgen@ege.edu.tr)

© The Author(s) 2021

W. Leal Filho et al. (eds.), *African Handbook of Climate Change Adaptation*, [https://doi.org/10.1007/978-3-030-45106-6\\_60](https://doi.org/10.1007/978-3-030-45106-6_60)

899



regulation have been imposed to the Laws of Zambia on environmental protection and pollution control legislative framework. Thus, both international regulations and local environmental protection and pollution control legislative have been used for identifying the potential sites and evaluating solar PV electricity generation potential in these potential sites. The restricting parameters were applied to reduce territory areas to feasible potential sites and available areas that are suitable for solar energy harvesting. The assessment involved two different models: firstly the assessment of potential sites and mapping using GIS, and secondly, evaluation of the available suitable land areas and feasible solar PV electricity generation potential in each provinces using analytical methods. The total available suitable area of the potential sites is estimated at 82,564.601 km<sup>2</sup> representing 10.97% of Zambia's total surface area. This potential is equivalent to 10,240.73 TWh annual electricity generation potential with potential to reduce CO<sub>2</sub> emissions in the nation and achieve SDGs. The identification of potential sites and solar energy will help improve the understanding of the potential solar energy can contribute to achieving sustainable national energy mix in Zambia. Furthermore, it will help the government in setting up tangible energy targets and effective integration of solar PV systems into national energy mix.

---

#### Keywords

Sustainable systems · Potential sites · Solar energy harvesting · Renewable energy · Zambia

---

## Introduction

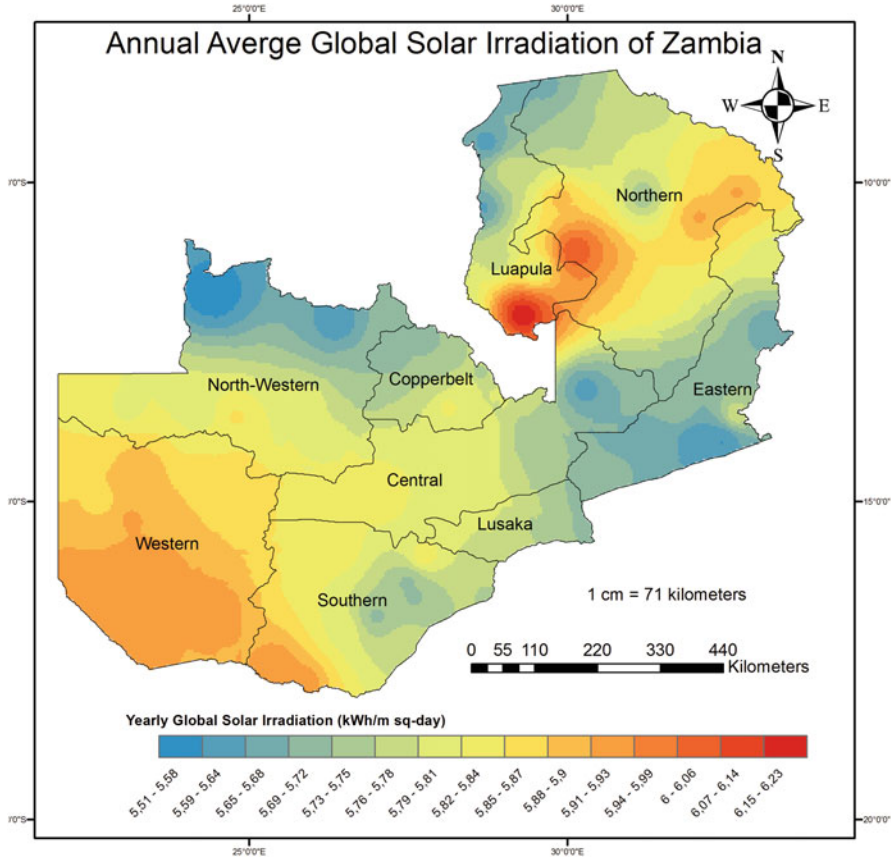
The purpose of meeting human basic needs and curbing climate change by reducing greenhouse gas emissions both at local and global levels has led to search for and establishment of energy policies for promoting renewable energy (Samuel and Owusu 2016; Sanchez-Lozano and García-Cascales 2014). The energy policies not only emphasized on promoting renewable energies but also on protecting natural resources and supporting natural environmental sustainability (Ivan 2015). Electricity generation from solar energy is in constant increase across the globe, but its share in the total energy production locally and globally still remains low as compared to fossil fuels. However, due to continual PV price decrease, increase in efficiency and maturity of technology in the last decades, feed-in tariffs including other incentives in many countries, has led to remarkable boom in photovoltaic (PV) technologies deployment and development both at utility-scale and residential levels across the globe (Robert 2014). According to International Energy Agency (IEA), the production of electricity from solar energy is expected to continue growing up to between 20% and 25% by 2050 (SEFI/UNEP 2009; Yassine 2011; Yassine and Adel 2012).

Despite of the remarkable boom in the application of solar PV technologies across the world, the application of these technologies in the electricity production in many developing countries like Zambia is still very negligible (Bowa 2017). However,

there are only a few examples of small isolated solar systems used by communities, schools, companies, private households, hospitals, and health centers. These systems are often used to meet the daily energy needs and to cover up energy needs during load-shedding period (MMWED 2008; Bowa 2017). One of the largest solar systems installed by government so far through Rural Electrification Authorities (REA) was built in 2010 in Samfya district Northern Province (installed capacity of 60 kW) (Bowa 2017). According to Bowa (2017), the estimated total installed capacity of solar photovoltaic-based power plants as of 2016 was more than 2 MW (small off-grid systems). Hence, despite of the country being located in most favorable solar belt (MMWED 2008) and receiving significant higher solar irradiation than most of world's largest solar energy utilizing countries, solar energy application for electricity generation has remained negligible. According to Meteorological Department of Zambia, the country has monthly average solar radiation incident rate of 5.5 kWh/m<sup>2</sup>-day (Gauri 2013; MMWED 2008; Walimwipi 2012; IRENA 2013). The solar radiation intensity across the country varies with western part of country having the highest annual average of approximately 5.86 kWh/m<sup>2</sup>-day and the eastern part with the lowest of 5.68 kWh/m<sup>2</sup>-day as shown in Fig. 1. Therefore, Zambia has a favorable climate conditions for utilization of solar energy for both production of electricity and thermal use. The total annual average global solar radiation ranges from 1981 kWh/m<sup>2</sup> in parts of North-Western, Eastern, Northern, Central, and Southern provinces to 2281 kWh/m<sup>2</sup> in parts of Luapula, Northern, and Western provinces of Zambia as illustrated in Fig. 2.

In order to increase access to electricity for all, the Government of Republic of Zambia has set targets and plans to encourage deployment and development of renewable energy facilities across the country, with hydropower and solar energy based on photovoltaic technologies expected to experience the greatest growth. However, despite of several tools being available across the globe for estimating the solar energy potential for particular location, these tools do not fully take into consideration the environmental and social issues. In addition, the surface land areas and the natural environment are some of the world scarce natural resources that require selection of the best use of these rare resources (Ronald 2016). Therefore, in order to safeguard the natural environment and consider best use of available surface land areas, energy planning and site selection for promotion and deployment of renewable energy technologies in individual countries has become one of the most challenging aspect more especially in developing countries like Zambia.

In addition, unified planning and poor site selection for intermitted renewable energy source based power plant have resulted in mismatch between the grid capacity and PV power plant output during peak time in some parts of the world (Siheng et al. 2016; Ming 2015). On the other hand, arbitrary site selection and neglecting the transmission line available reserve margin in the procedure have resulted in some PV power plant exceeding the local transmission line reserve margin and grid unable to transmit the energy to the load centers during peak hours (Chinairn 2013; Aly Sanoh 2014; Quansah 2016). Therefore, preliminary estimation and mapping of potential sites, available areas, and technical energy yield potential for intermitted renewable energy source based power plant

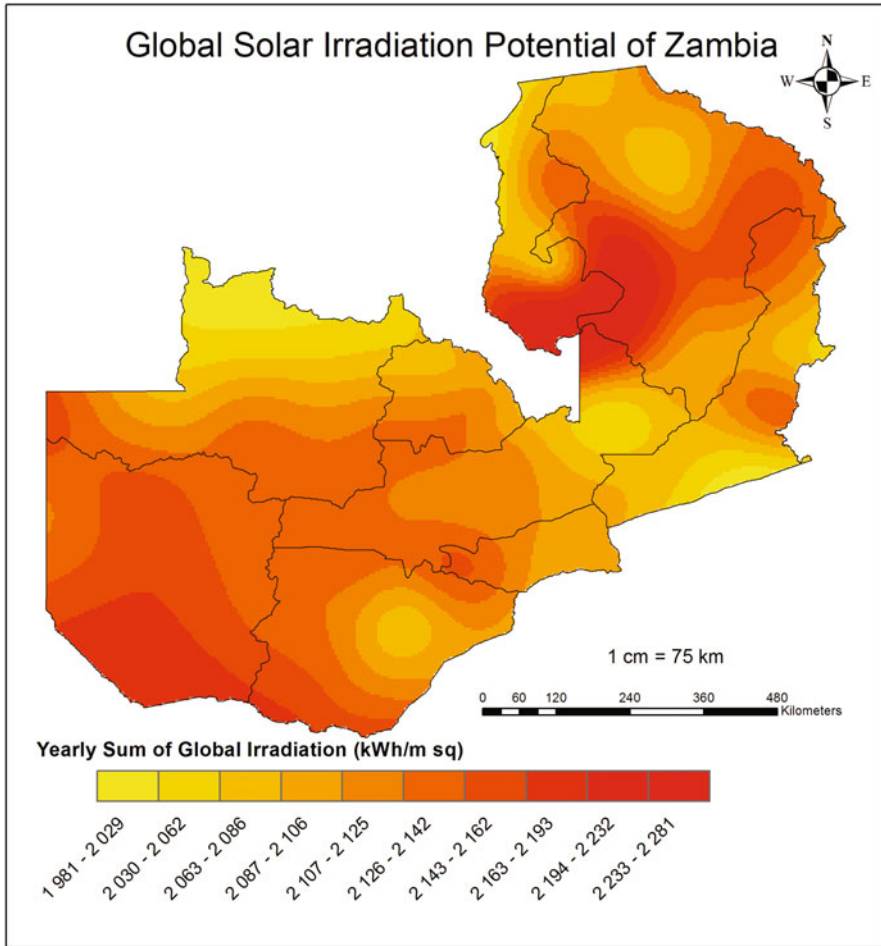


**Fig. 1** Annual average horizontal solar irradiation

deployment while considering social acceptability and supporting natural environmental sustainability can be helpful to overcome these problems (Siheng et al. 2016). Doing so also helps to avoid and minimize potential negative environmental and social impacts associated with deployment of these technologies. The preliminary estimates and mapping of potential sites and technical energy yield potential for solar photovoltaic power plant development, however, have not been made in most developing countries like Zambia due to various reasons.

However, selection of potential site and evaluation of technical electricity generation potential requires a number of finer spatial resolution data, since not all locations of any particular country are suitable for deployment of these technologies due to local landscape terrain, climate, and environmental regulations (Suri 2005).

This chapter aims at providing a method for identifying and mapping a series of the potential sites and the available land areas suitable for solar energy harvesting in Zambia. The chapter further provides a method for assessing the electricity generation potential from solar energy based on commercially available solar photovoltaic technologies and available land areas. The evaluations in this chapter considered the



**Fig. 2** Annual total global solar radiation intensity (Mwanza et al. 2016a)

modules of the solar PV systems mounted at optimal tilt position to the ground. The analysis focused on solar radiation, available areas, and typical energy that can be generated from the PV system considering the solar PV module characteristics and available solar radiation of the potential sites. The results of this study are important as it provides summarized information with regard to suitable potential sites, available land area, and technical electricity generation potential that can be attained from using solar photovoltaic technologies across Zambia.

## Geographical Description

Zambia is unique country endowed with variety and abundant nature resources, such as wildlife resources, watercourse resources, forests resources, minerals resources,

and renewable energy resources. Its abundant renewable energy resources such as solar energy are heavily untapped. The country is also blessed with unique climate and geography of flatland in most part of the country. It is situated between latitudes  $8^{\circ}$  and  $18^{\circ}$  south of the equator and longitudes  $22^{\circ}$  and  $34^{\circ}$  east of prime meridian. The country is landlocked by eight countries, Zimbabwe and Botswana to the South, Angola to the West, Democratic Republic of Congo and Tanzania to the North, Malawi and Mozambique to the East, and Namibia to the Southwest (Mwanza et al. 2016a).

---

## Solar Photovoltaic Power Plant Sitting Considerations

### Environmental and Social Issues

Solar energy is clean, free, and unlimited renewable energy sources that can be used for variety of purposes including pumping water for irrigations, drying and preparing food, and most importantly for electricity generation. However, just like any other alternative energy supply option, solar photovoltaic technology deployments at utility-scale are not free from imposing negative effects on both the environment and society ([www.energy.gov](http://www.energy.gov)) (Wang and Prinn 2010; Union of Concerned Scientists 2015). Most of these effects depend on development size, site, and the type of technology deployed and also site selection and environmental guidance procedure. The environmental and social impacts associated with renewable energy technology development are mainly grouped as listed in Table 1 (Ahmed Aly 2017; Turlough 2017; Shifeng and Sicong 2015; Kaoshan et al. 2015; Fylladitakis 2015; Saidur et al. 2011; Gipe 1995; Interior Department 2010; Damon and Vasilis 2011; U.S 2016; Geoffrey and Tidwell 2013; England 2011; Tsoutsos 2005, 2009).

### Restricting Issues

The potential impacts associated with utilization of renewable energy technology have potential to hinder or delay deployment and development of solar photovoltaic technologies or facilities in potential sites. Table 2 and Figs.3, 4, 5, 6, 7, 8, 9, 10, 11, and 12 list solar PV systems deployment restricting issues that have, among others, been considered for inclusion, as appropriate, in the available land area, technical electricity generation potential, and potential sites assessment for sustainable solar photovoltaic facilities development in Zambia based on highlighted environmental and social impacts ([www.energy.gov](http://www.energy.gov); Abdolvahhab Fetanat 2015; Alami et al. 2014; Ahmed et al. 2017; Arthur Bossavy 2016; Addisu and Mekonnen 2015; Marcos Rodrigues 2010; Anthony Lopez 2012). Restricting criteria data are features that

**Table 1** Summarized environmental and social impacts induced by solar photovoltaic power Plants

Type of impact	Causes	Factors contributing	Effects
Noise pollution	Inverter noise due to internal electronics, transformer noise, construction noise	Air temperature, humidity, ground surface material, background noise, heavy machinery, human activity	Sleep disturbance, hearing losses, headaches, irritability, fatigue, constrict arteries, weaken immune systems, annoyance, or dissatisfaction
Air and water pollution	PV module: Toxic materials, heavy machinery & transformers: Oil, switchgear breaker gas SF <sub>6</sub> , ground clearing and grading	Fire, module cracking, leaking machinery due to poor maintenance, leakages in switchgear, transformers, & machinery, access roads & ground preparing	Death, injuries, loss of ecosystem, contamination of soil, water, and air
Water use	Periodic maintenance: PV module surface cleaning, construction activity, dust abatement activities	Dust, wind, location, size of facility, system performance, unpaved roads	Reduced underground water recharge, reduced surface water flow, agriculture water problem, wildlife water problem, human water problem
Climate Change & Greenhouse gas (GHG) emissions	Concrete and steel for PV array mounting foundations	Size of PV array, location of facility	CO <sub>2</sub> emission; global warming
Wildlife & Habitat loss	Excavation, grading, ground clearing, road & electrical grid construction	Location, landscape topography, size of facility, distance to road and electrical grid	Loss of feeding, nesting or roosting grounds for animals, birds, ecosystem disturbance, wildlife reduction
Visual impact	Distance to residential areas, size of facility, night lights at power plant, human perception	Scenic backgrounds, local landscape topography, local landscape between solar plant and viewers, location of solar farm, color of PV panels, layout of solar farm; irregular or regular, clear skies	Aesthetic effects, public health, negative perception of solar energy technologies, visual effect

(continued)

**Table 1** (continued)

Type of impact	Causes	Factors contributing	Effects
Land use/ Soil & Land Degradation, fugitives dust	Power grid & access road construction, PV array foundation excavation, removal of surface plants, wastewater and oil from construction machinery, excess wastes from construction: Plastics, metal, glues, & inks	Layout of solar PV farms, location of solar PV farm, landscape topography, type of PV technology, tilt angle of modules, distance to access road and electrical grid, office wastes	Deforestation, soil erosion, loss of habitat, landslide, floods, air and water pollution, ecosystem disturbance, fugitive dust

**Table 2** Restricting issue datasets

Type of impact eliminated, minimized or avoided	Site descriptions	Detail nature of sites descriptions
Water use, Wildlife & Habitat Loss	Wildlife sites	National parks and game reserves
Visual impact, Noise Pollution & Land use/degradation, fugitives dust	Community interest sites	Airfields, historical sites, archaeological sites, traditional and cultural heritage sites, national monuments sites and tourism sites, religious significance sites
Water use, land use/degradation	Agriculture sites	Crop areas and potential agriculture areas
Fugitive dust, water use, air/Noise Pollution & Visual Impact, land use	Settlement sites	Rural/urban and residential areas: Towns, cities, villages, and areas used extensively for recreation and aesthetic reasons
Water pollution, Wildlife & Habitat Loss, land degradation	Surface water bodies and surrounding sites	Rivers, lakes, streams, waterfalls, and wetlands
Land degradation, Wildlife & Habitat Loss	Landscape	Land elevation and slope (>5degrees), areas prone to flooding and natural hazards, zones prone to erosion or desertification, zones of high biological diversity, areas supporting populations of rare and endangered species,
Land use, Wildlife & Habitat Loss, fugitive dust, water, air and soil pollution, visual impact	Right of way	Transmission, roads and railroads network right of way
Wildlife & Habitat Loss, climate Change & Greenhouse gas (GHG) emissions, land degradation	Forest and surrounding sites	Forests: Low need-leaved deciduous forest and moderate evergreen deciduous forest, shrub-lands: Closed to open shrub-land and open shrub-land, grassland: Sparse grassland, indigenous forest

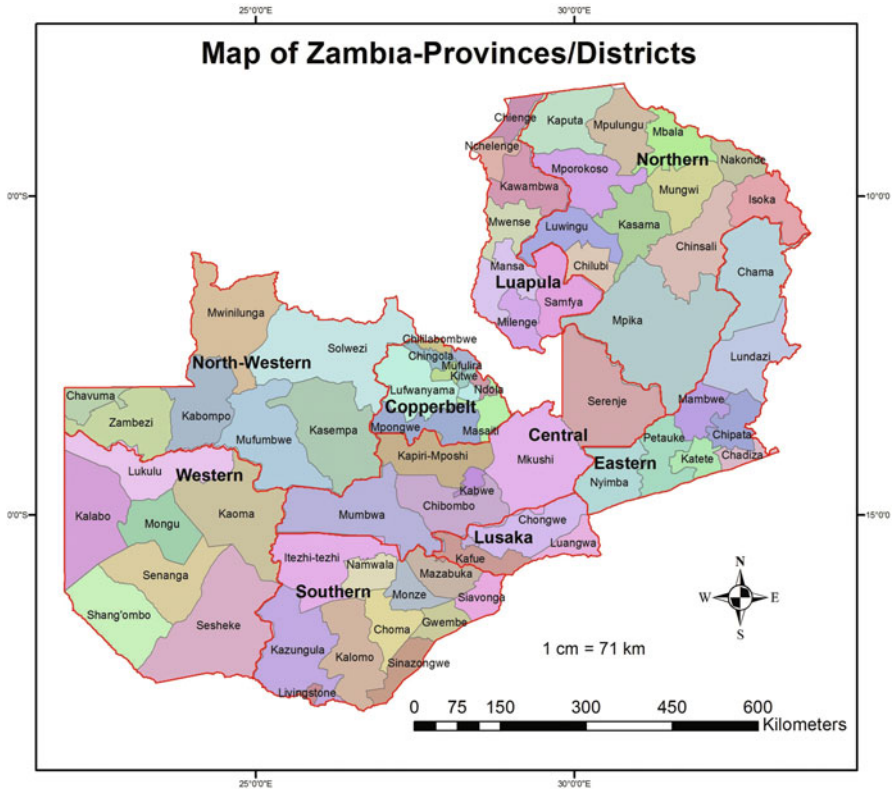


Fig. 3 Administrative boundary map

pose restrictions or limitations, that is, unsuitable or not preferred areas based on legislative laws of the country and nature.

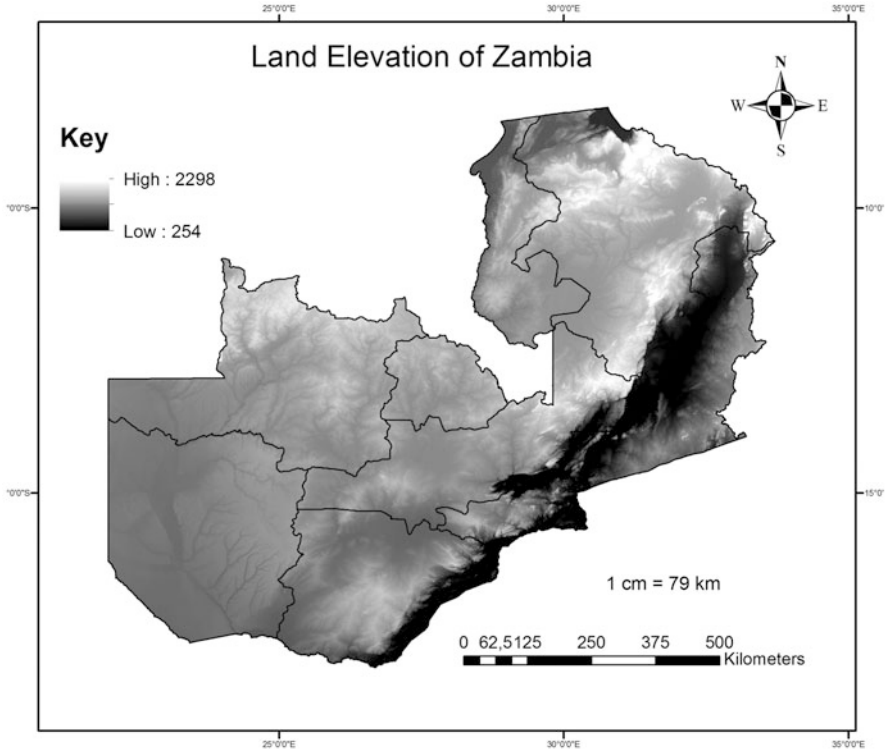
## Potential Site Identification and Mapping

### Solar PV Potential Site Identification and Mapping

In order to assess the potential sites suitable for utility-scale solar photovoltaic deployment based on literatures surveyed and the laws of Zambia on environmental for development of any industry or plant on a particular site and restrictions datasets summarized in Table 2. Thus, the following environmental and social impacts and issues illustrated in Table 3, among others, are considered for inclusion, as appropriate, in the selection of suitable sites for solar energy facilities (ECZ 1994).

These maps included land elevation map (DEM), land use/cover layer map, town and village location map, community interest sites map, national parks map, surface water bodies map, roads and railway map, study area boundaries, and transmission

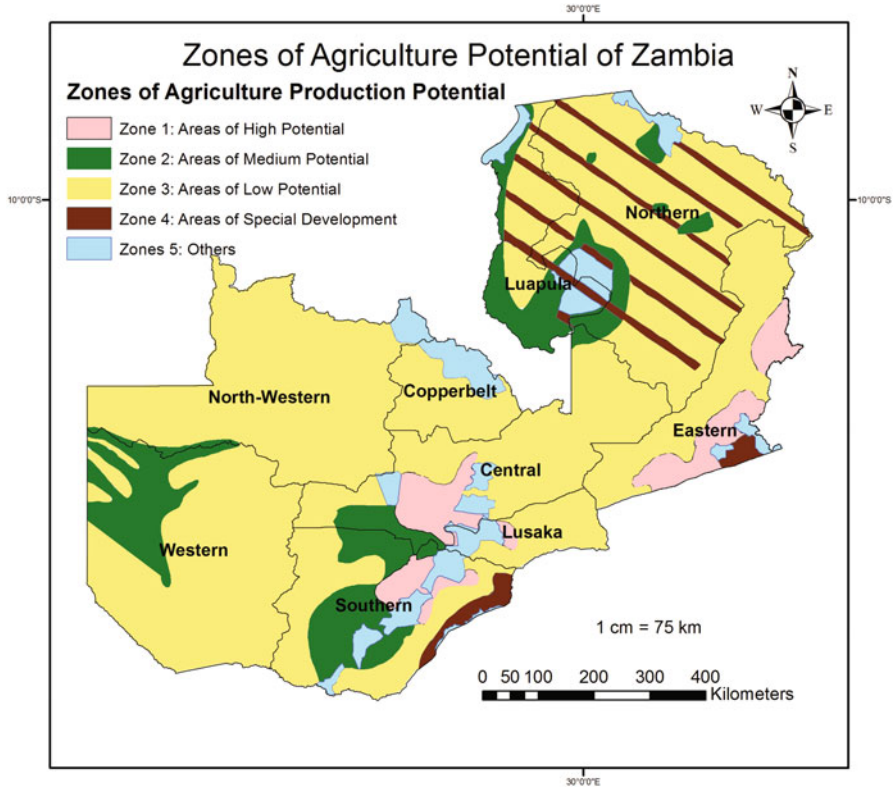




**Fig. 4** Land digital elevation map

line maps (Nazli Yonca 2010; Sanchez Lozano et al. 2013, Brewer 2014, Chao-Rong Chen 2014, Charabi and Gastli 2011, Lopez 2012, Janke 2010; Uyan 2013). The rationale used for each restrictions are as follows:

- **Land Use/Cover (C6, C9):** This dataset has 10 classes including bare land, closed to open shrubland, open shrubland, sparse grassland, croplands, urban settlement, water courses, wetland, and forest sites; low need-leaved deciduous forest and moderate evergreen forest. For deployment of solar PV power plants only bare lands, sparse grassland and open shrubland were considered suitable due to easy accessibility considering an emerging economy and also to reduce land clearing costs.
- **Wildlife Sites (C2):** this dataset considers areas such as national parks, game reserves, and other natural resources since development in these sites will have adverse impact on birds, animals, and ecology, thus any construction in these areas may face public and international resistance. Therefore, these areas and the surrounding areas within the buffer of 2 km were considered not suitable (Nazli Yonca 2010).



**Fig. 5** Zones of agriculture production potential

- **Settlement and Community Interest Sites (C4, C1):** The dataset consists of settlement areas for both rural and urban such as airfields, airports, towns, villages, and other dwelling areas and community interest sites. Here a buffer of 3 km is considered to avoid aforementioned impacts and increase public safety and acceptance. All areas outside the buffer were considered suitable (Joss and Watson 2015).
- **Land Elevation (C7):** As it is expected that no one will install solar PV power plants in gorges or higher elevation due to construction costs. Thus, this dataset considered all higher and lower elevations such as mountains and gorges with steeper slopes above  $5^{\circ}$  as unsuitable areas.
- **Surface Water Bodies (C8):** In this dataset all surface water bodies such as rivers, streams, lakes, including waterfalls, and wetlands were considered as protected areas in order to avoid water pollution. Thus, a buffer of 2 km was considered with all areas outside buffer being suitable.
- **Roads and Railways Network (C3):** The dataset considers roads and railway network to be restriction since no one is supposed to build on roads or railway and

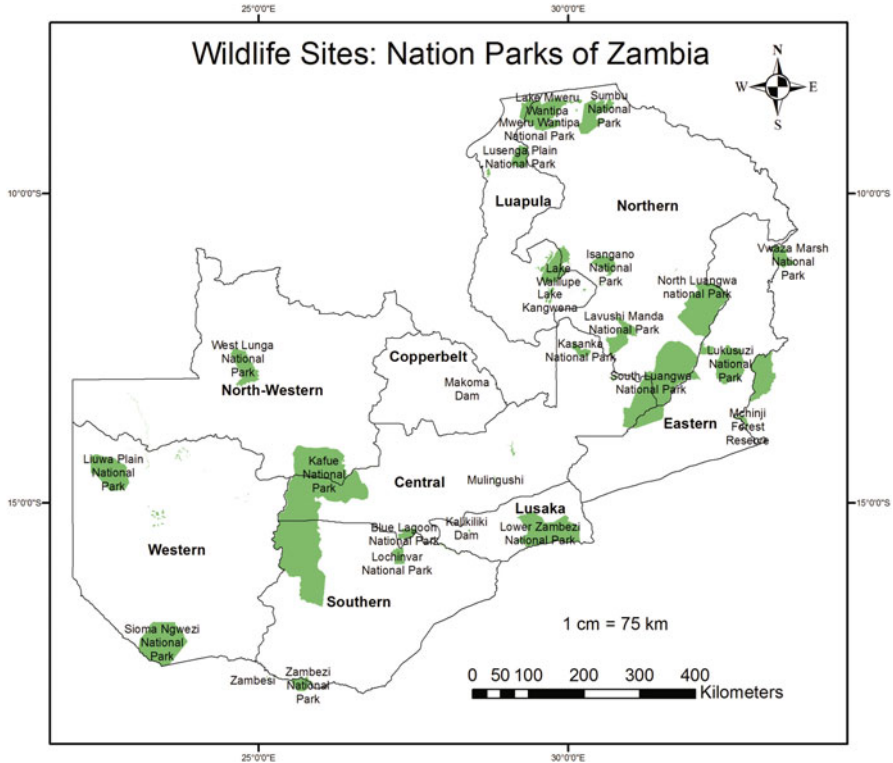
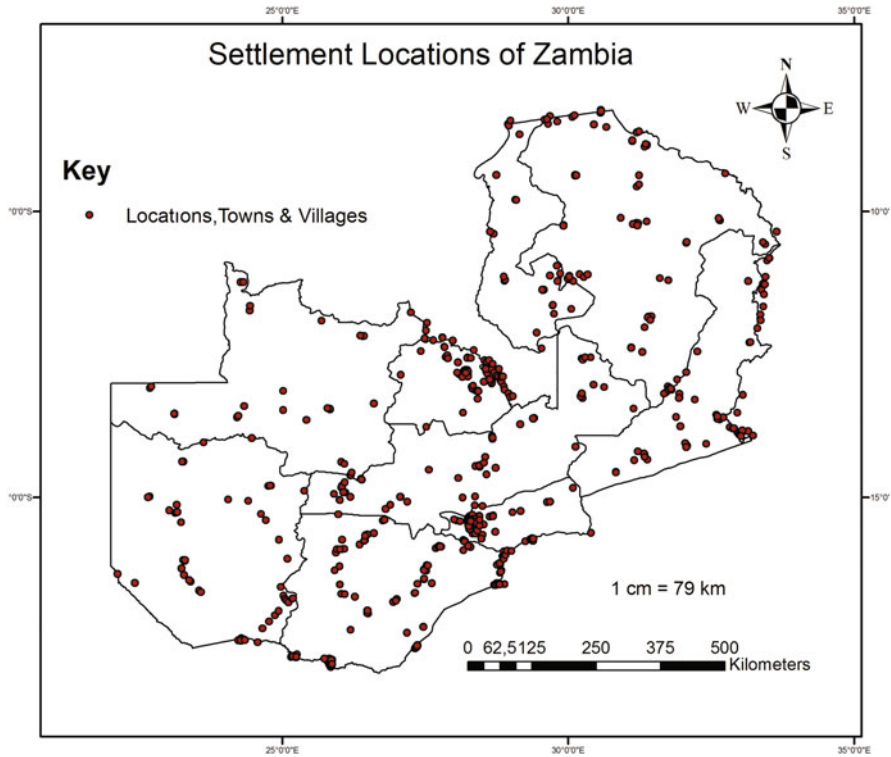


Fig. 6 Wildlife areas: national parks

also for the safety of the public. Hence, a 0.5 km buffer has been considered in order to increase public safety and also reduce cost of constructing access road which usually leads to land use/degradation, wildlife and habitat loss, fugitive dust, and air and soil pollution to the site and surrounding areas. Thus, the areas outside the buffer are considered suitable.

- **Transmission Line Network (C5):** In this dataset the right of way for transmission line were considered as unsuitable area for solar PV power plants, thus a 0.5 km buffer was used. Any areas within the buffer were considered unsuitable. The 0.5 km buffer were considered so that the cost of constructing new transmission lines is reduced, but at the same time to avoid conflict with right of way for transmission lines and avoid land use/degradation, wildlife and habitat loss, fugitive dust, water, and air and soil pollution to the site and surrounding areas.

After creating buffers, and changing some features from vector to raster, in order to evaluate available areas and identify/map feasible potential sites, the created buffers for the restricting layers were overlaid on each other using GIS spatial analysis. Figure 13 below shows the summarized analysis procedure.



**Fig. 7** Settlement and community interest sites

### Available Land Area

In order to estimate the available suitable areas for solar photovoltaic power plant development based on aforementioned restrictions issues, a new factor called Area Suitability factor  $f_{SF}$  was introduced. It is defined as the ratio of total grid cells of suitable surface area to the total cells of the study surface area. The factor is estimated based on study area grid cells; here the total grid cells for study surface area are evaluated considering the sum of restricted and suitable surface areas' cells. Hence the factor depends on the ratio of available suitable area and surface area of the study area and it is calculated using the expression below.

$$f_{SF} = \left( \frac{C_{CSA}}{C_{CSA} + C_{CRA}} \right) = \frac{C_{CSA}}{C_{TSSA}} \tag{1}$$

where  $C_{CSA}$  is the total number of cells of suitable areas,  $C_{CRA}$  is the total number of cells of restricted areas, and  $C_{TSSA}$  is total number of cells of study area.

Therefore, the total available suitable land areas for each district and for Zambia were evaluated using expression 2 given below

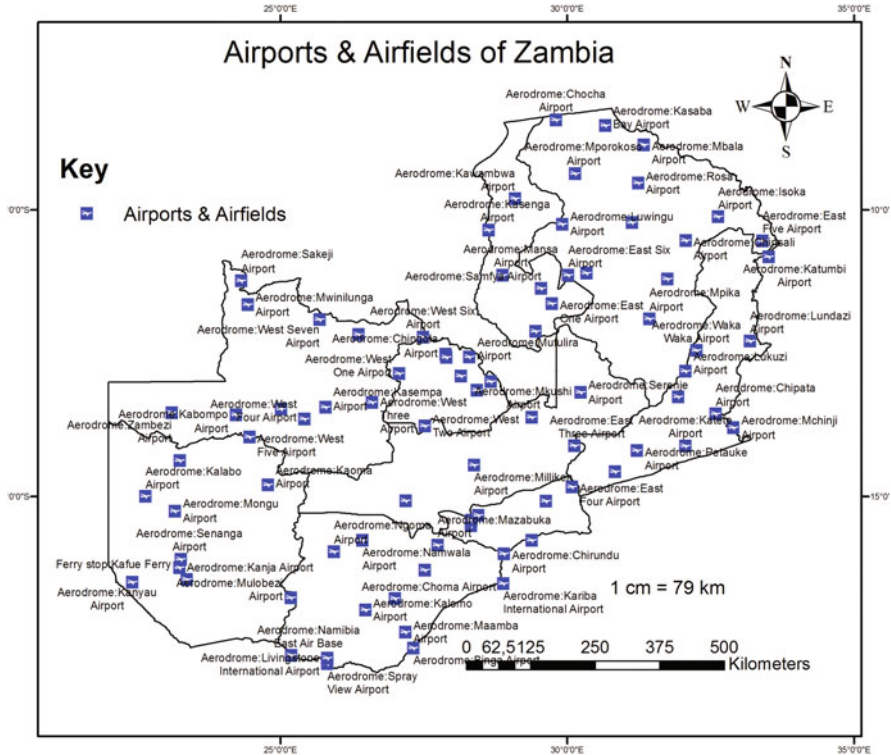


Fig. 8 Airports and airfield

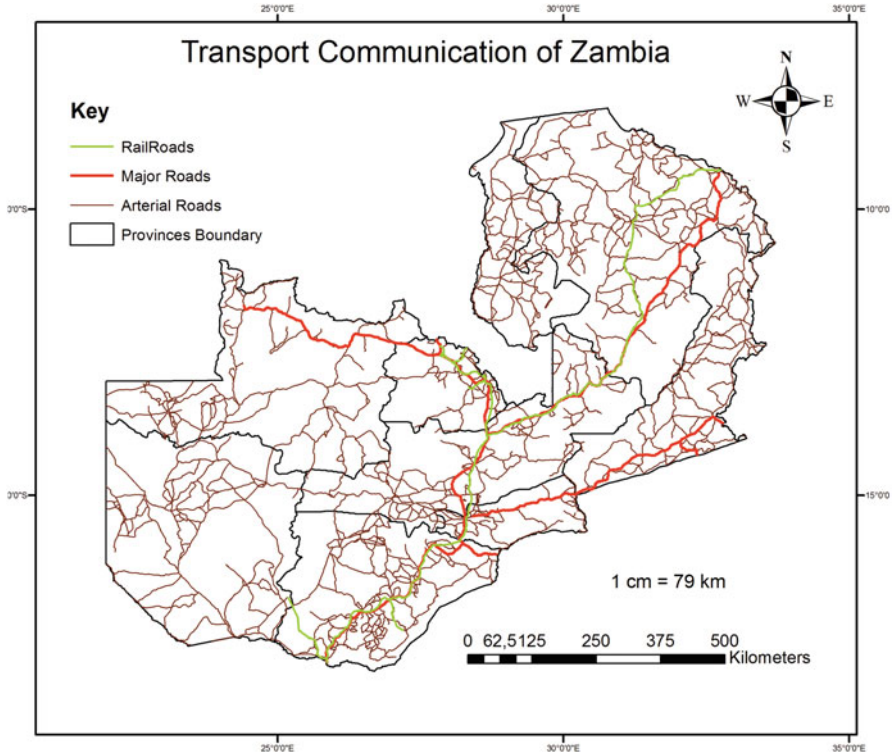
$$A_{ADS} = f_{SF} \cdot A_{TSA} \tag{2}$$

where  $A_{ADS}$  is total available suitable areas ( $\text{km}^2$ ), and  $A_{TSA}$  is total surface area of the study area ( $\text{km}^2$ ).

### Electricity Generation Potential

#### Solar Energy Potential in Zambia

According to the literature and data undertaken by Meteorological Department of Zambia, the country has a significant potential of solar energy for both electrical power production and thermal from solar energy technologies. The country has average peak sunshine of about 6–8 hours per day and monthly average solar radiation of  $5.5 \text{ kWh/m}^2\text{-day}$  throughout the year (MMWED 2008; Walimwipi 2012). According to International Renewable Energy Agency (IRENA 2012), the country has the highest total yearly solar radiation of  $2,750 \text{ kWh/m}^2\text{-year}$  with the highest average temperature of  $30 \text{ }^\circ\text{C}$ , which presents good opportunity for solar systems deployment (IRENA 2012).



**Fig. 9** Road and railroad networks

### Performance of PV System

In order to evaluate the performance of grid connected PV power plants, the following performance indices are normally used: yields, normalized losses, and system efficiencies, performance ratio, and capacity factor – (British Standard 1998). However, in this chapter final yield, performance ratio and capacity factor have been adopted for analyzing the PV system performance of the various types of PV technologies commercially available on the market (Table 3) considering Zambia's weather condition. In addition, several PV technologies have been considered in the evaluation of technical electricity generation and power potential: firstly, because the energy generation by PV power plants with same peak power and receiving same amount of solar irradiation differs depending on the type of technology employed in the power plants, and secondly, the amount of peak power that can be installed at a given land area differ with PV technologies as shown in Table 4. Hence, it can be concluded that the type of cell technology has greater influence in the amount of land area needed for a peak power installation, the higher the efficiency the lower the land requirements for the peak power capacity installation (Martin-Chivelet 2016).

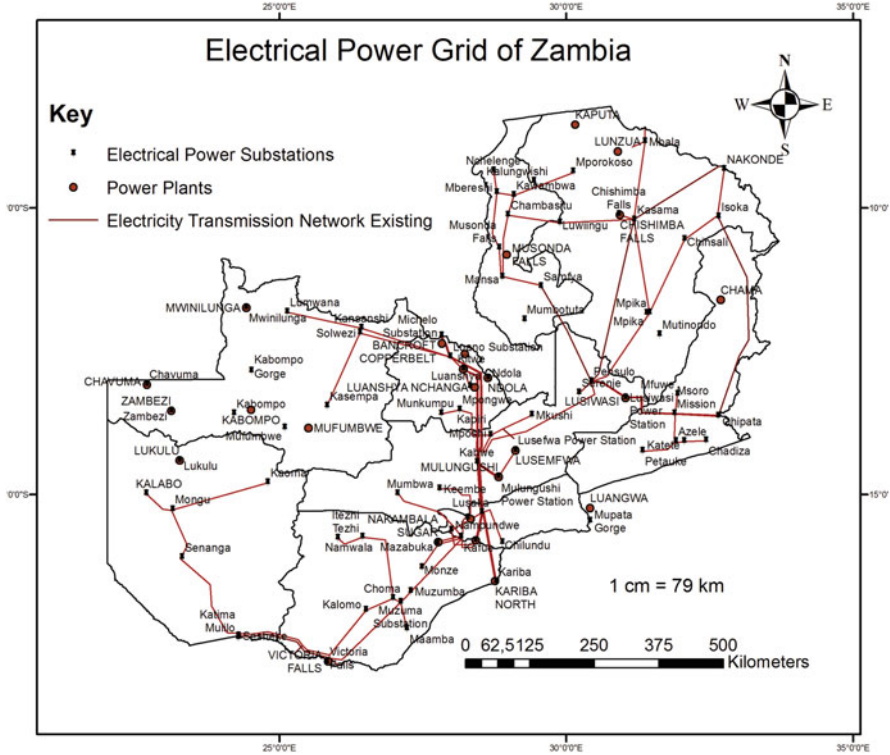


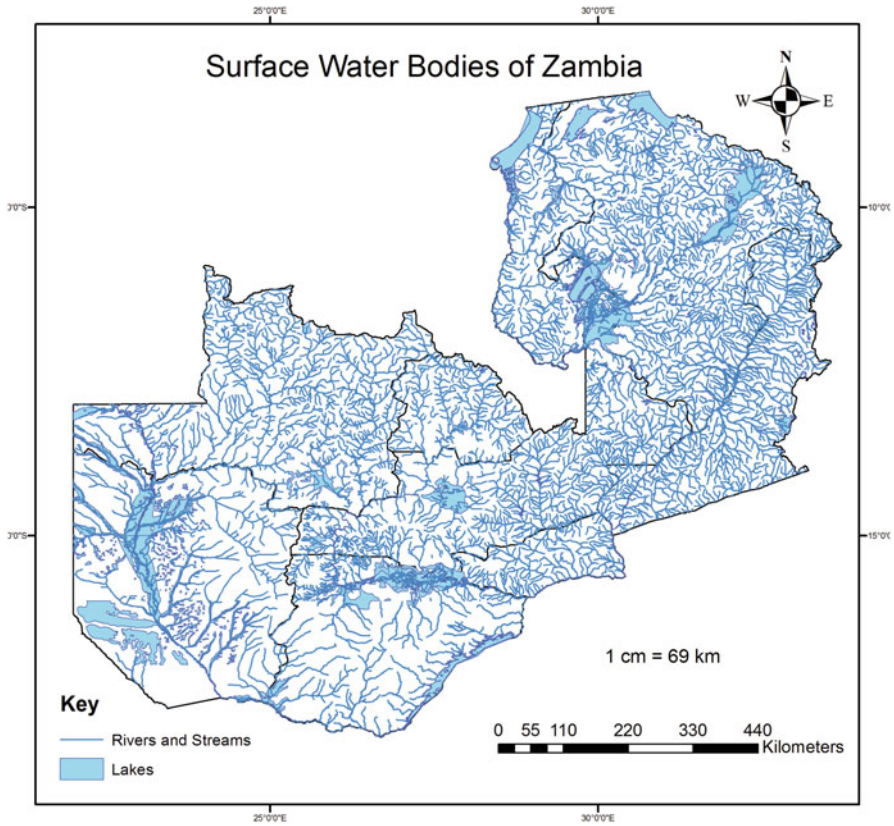
Fig. 10 Existing electrical network

**Energy Model of PV Array**

The solar energy resources are the key determinants of PV system electricity generation (IRENA 2012). The higher the solar energy resources, the more output yield of a PV systems per kilowatt. However, higher temperatures, dust, shading, balance of system inefficiencies, and PV technology characteristics have negative impact on the PV system energy yield (Didler 2012). Therefore, the electricity generated and supplied to grid by PV system considering these negative impacts has been estimated using Eq. 3:

$$E_A = A_{PV} \cdot H_R \cdot \eta_p (1 - \lambda_p) (1 - \lambda_c) \tag{3}$$

where  $E_A$  is energy output of PV system (MWh/year),  $H_R$  is solar radiation on the surface of module (kWh/m<sup>2</sup>-day),  $A_{PV}$  is PV system active area (m<sup>2</sup>),  $\eta_p$  is module efficiency under STC condition,  $\lambda_p$  is miscellaneous module losses due to dusty covering, and  $\lambda_c$  is losses due to power conditioning unit and cable losses. Module efficiency is a function of its nominal efficiency,  $\eta_n$ , which is measured at STC  $T_r = 25\text{ }^\circ\text{C}$  (Didler 2012). It has been calculated as:



**Fig. 11** Surface watercourses and streams

$$\eta_p = \eta_r \cdot [1 - \beta(T_c - T_r)] \tag{4}$$

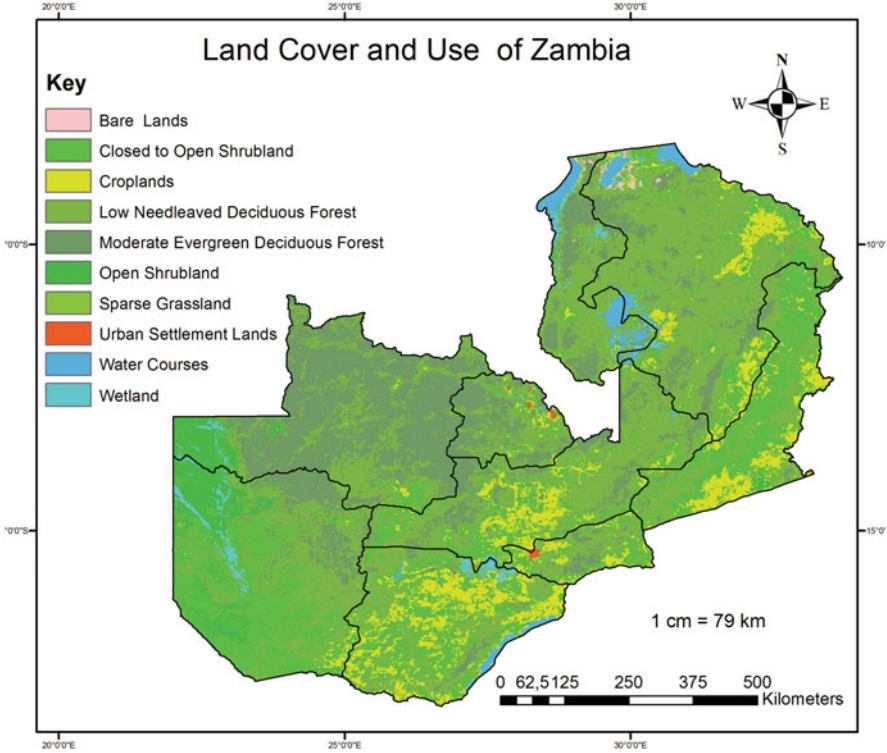
where  $\beta$  is a temperature coefficient for module efficiency,  $T_c$  is a module temperature due to air temperature, and  $T_r$  is STC reference temperature.

Module temperature is related to the average monthly ambient air temperature,  $T_a$ , for a local condition has been calculated using Eq. 5 (Didler 2012).

$$T_c; = T_a + \frac{G_T}{G_{T,NOCT}} \left( \frac{9.5}{5.7 + 3.8V_w} \right) (T_{c,NOCT} - 20)(1 - \eta_m) \tag{5}$$

where  $G_T$  is solar irradiance ( $W/m^2$ ),  $T_a$  is ambient air temperature ( $^{\circ}C$ ), and  $V_w$  is wind speed(m/s) for the location,  $T_{c,NOCT}$  is nominal operating cell temperature (Table 3), it depends on type of PV technology,  $\eta_m$  is the factor less than 1 and normally neglected and  $G_{T,NOCT}$  is  $800 W/m^2$ .





**Fig. 12** Land aspects

**Performance Ratio Model**

Performance ratio is denoted by PR, this factor is important as it shows the overall effect of losses on the PV array’s rated output power due to the PV array temperature, incomplete use of the solar irradiation, and PV system component inefficiencies or failures. It is calculated as (British Standard 1998).

$$PR = \frac{Y_F}{Y_R} = \frac{E_{AC}}{G\eta_{STC}} \tag{6}$$

where G-standard test condition solar radiance (1 kW/m<sup>2</sup>) and η<sub>STC</sub>-array efficiency at standard test condition given as.

$$\eta_{STC} = \frac{P_{PV}}{GA_{PV,A}} \tag{7}$$

where A<sub>PV,A</sub>-Active array area (m<sup>2</sup>) and P<sub>PV,A</sub>- array rated power (kW<sub>P</sub>).

**Table 3** Environmental and social consideration for site selection in Zambia (ECZ 1994)

Issues	Considerations	Effect description
<i>Ecological</i>	(a) <i>Biological diversity:</i>	<ul style="list-style-type: none"> <li>• Effect on number, diversity, breeding sites, etc. of flora and fauna</li> <li>• Effect on the gene pools of domesticated and wild sustainable yield</li> </ul>
	(b) <i>Sustainable use including:</i>	<ul style="list-style-type: none"> <li>• Effect of soil fertility</li> <li>• Breeding populations of fish and wildlife (game)</li> <li>• Natural regeneration of woodland and sustainable yield</li> </ul>
	(c) <i>Ecosystem maintenance including:</i>	<ul style="list-style-type: none"> <li>• Effects of proposal on food chains</li> <li>• Nutrient cycles</li> <li>• Aquifer recharge, water run-off rates, etc.</li> <li>• Aerial extent of habitats</li> <li>• Biogeographical processes</li> </ul>
<i>Social, economic, and cultural</i>	<ul style="list-style-type: none"> <li>• Effects of generation or reduction of employment in the area</li> <li>• Social cohesion or disruption (resettlement)</li> <li>• Immigration (including induced development when people are attracted to a development site because of possible enhanced economic opportunities)</li> <li>• Communication-roads opened up, closed, re-routed</li> <li>• Local economic impacts</li> </ul>	
<i>Land scope</i>	<ul style="list-style-type: none"> <li>• Views opened up or closed</li> <li>• Visual impacts (features, removal of vegetation, etc.)</li> <li>• Compatibility with surrounding areas</li> <li>• Amenity opened up or closed, e.g., recreation facilities</li> </ul>	
<i>Land use</i>	<ul style="list-style-type: none"> <li>• Effects on land uses and land potential in the project area and in the surrounding areas</li> <li>• Possibility of multiple use</li> </ul>	
<i>Water</i>	<ul style="list-style-type: none"> <li>• Effects on surface water quality and quantity</li> <li>• Effects on underground water quality and quantity</li> <li>• Effect on the flow regime the water course</li> </ul>	
<i>Air quality</i>	<ul style="list-style-type: none"> <li>• Effects on the quality of the ambient air of the area</li> <li>• Type and amount of possible emissions (pollutants)</li> </ul>	

### Capacity Factor Model

This is a model used to show the amount of energy delivered to the grid by an electric power generation system (Ayompe 2014). It is defined as the ratio of the output actual annual energy generated by PV system to the amount of energy the PV system would generate if it is operated continuously at full rated power for 8,760 hours in a year and it is expressed as (Ayompe 2014; Kynakis 2009; British Standard 1998).

$$CF. = \frac{E_{AC}}{8760 \times P_{PV}} = \frac{PR \times H_t}{8760 \times P_{PV}} \quad (8)$$

where CF is capacity factor (%),  $E_{AC}$  is Actual annual energy output (kWh/year), and  $P_{PV}$  is Full rated PV power (kW<sub>p</sub>).

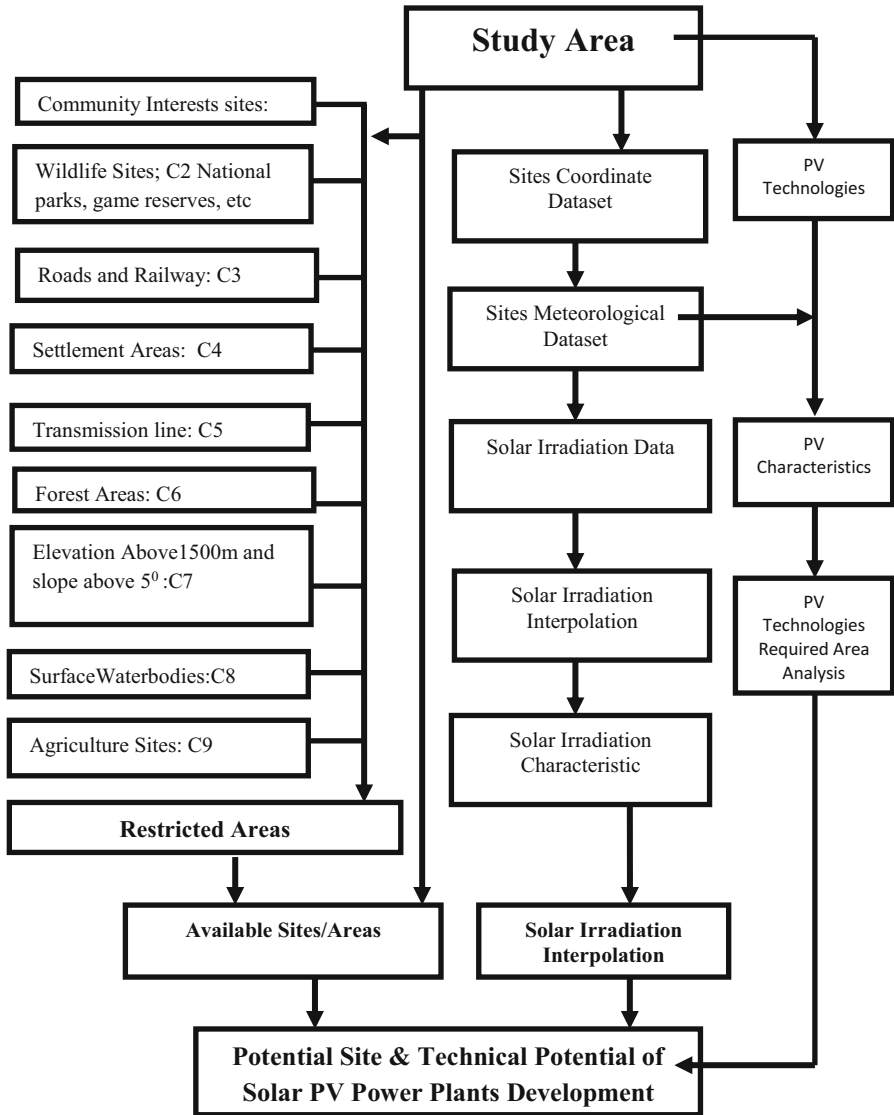


Fig. 13 Analysis Procedure

### Solar Energy Potential Model

#### Theoretical Solar Energy Potential Model

Theoretical solar energy potential involves the assessment of the total solar energy that is received at the surface of the study area. This potential involves identifying the study area boundary and the size of the study land area, including total annual

**Table 4** PV technology parameters

PV technology parameters	PV technologies					Reference
	mc-Si	Pc-Si	a-Si	CIS	CdTe	
Efficiency (%)	23	16	7–10	12.1	11.2	IRENA 2012
Temp. Coeff. $\beta$ (%/°C)	0.41	0.43	0.27	0.26	0.25	Suprava and Pradip 2015
Active PV area needed (m <sup>2</sup> /kW)	7	8	15	10	11	IRENA 2012
Total PV system area needed (m <sup>2</sup> /MW)	14,000	16,000	30,000	20,000	220,000	Estimated
NOCT (°C)	47	45	40.3	45.6	45	Suprava and Pradip 2015
Max. PV module (W)	320	320	300	120	120	IRENA 2012
BOS losses (%)	8	8	8.13	11.33	11.33	Various sources
Dust factor (%)	5	5	5	5	5	Various sources

average solar radiation magnitude. The theoretical potential has been calculated using Eq. 9:

$$E_{TH} = A_S \cdot H_P \quad (9)$$

where  $E_{TH}$  is theoretical solar energy potential (MWh/year),  $A_S$  is study area active surface area (km<sup>2</sup>), and  $H_R$  is total annual average solar irradiance (MWh/km<sup>2</sup>-year).

### Geographical Solar Energy Potential Model

Geographical solar energy potential involves assessing the solar energy that is received on the available and suitable land area of the active surface land area of study area (Lopez 2012). Hence, the process of assessing this potential involved firstly excluding all the protected and restricted areas from the active surface area of the study area under consideration (Yan-wei 2013; Lopez 2012).

Therefore, the remaining surface land area is taken as the most suitable land area of the total study area surface land area for solar energy technologies development. In this study, the geographical solar energy potential has been estimated using Eq. 10 given below:

$$E_G = A_{AOS} \cdot H_R \quad (10)$$

where  $E_G$  is geographical solar energy potential (kWh/year),  $A_{ADS}$  is Available Suitable Area (m<sup>2</sup>), and  $H_R$  is total annual average solar radiation (kWh/m<sup>2</sup>-year).

### Solar PV Technical Power Potential Model

The process of assessing the feasible solar PV technical potential, that is, the maximum power capacity that can be installed for any country without environmental and social impacts involves firstly by excluding restricted areas and areas not suitable for utility-scale PV systems development within the defined boundaries. Furthermore, considering technical characteristics of solar PV technologies (Table 3) to convert the solar energy to electrical energy, the total solar energy that is received at the surface of the solar PV module and the area required by the PV system and its supporting infrastructures. Hence, the technical solar PV potential has been estimated using Eq. 11 (Yan-wei 2013; Lopez 2012):

$$P_{TP} = \left( \frac{A_{ADS}}{A_{PVSA}} \right) \cdot P_{PD} A_{PV} \quad (11)$$

where  $P_{TP}$  is Solar PV Power Potential (MW),  $A_{PVSA}$  is Solar PV system and Supporting Infrastructure Occupied Area per MW ( $\text{km}^2/\text{MW}$ ),  $A_{ADS}$  is Available Suitable Area for Study Area ( $\text{km}^2$ ),  $A_{PV}$  is total geographical occupied area by PV system and supporting infrastructure ( $\text{km}^2$ ), and  $P_{PD}$  is solar power density of the area ( $\text{MW}/\text{km}^2$ ).

### Solar PV Systems Electricity Generation Technical Potential Model

The total AC electricity generated by the PV system is the sum of the electricity produced by all array in the PV power plant measured at the point where the system fed to utility grid. The total daily  $E_{AC,DP}$  and monthly  $E_{AC,mP}$  AC energy generated by plant are expressed as (Ali et al. 2016; Tripathi et al. 2014; Siyasankari and Babu 2015):

$$E_{AC,DP} = \sum_{t=1}^{24} E_{AC,t} \quad (12)$$

$$E_{AC,mP} = \sum_{d=1}^N E_{AC,DP} \quad (13)$$

where  $N$  is number of days in the month, and  $E_{AC,t}$  is energy produced by PV power plant per hour (kWh).

Utility-scale photovoltaic are large-scale solar PV power plant that can be deployed within the boundaries of the country on an open space land area (Lopez 2012). Several studies have considered that the modules covers the available suitable areas on horizontal; however, the method proposed in this study seeks to consider the active area of PV arrays only and also the supporting infrastructures in the evaluation of technical potential. The process of assessing the extractable electricity generation potential from the sun for any country involves firstly by excluding areas not suitable for utility-scale PV systems within the defined boundaries, and secondly, considering technical characteristics of PV systems to convert the solar energy to electrical

energy and the area required by the PV system and its supporting infrastructures. In this study the technical solar energy potential was estimated using Eq. 14 (Yan-wei 2013; Lopez 2012):

$$E_T = P_{TP} \cdot CF \cdot T_{TSH} \quad (14)$$

where  $E_T$  is Solar PV Electricity Generation Potential (MWh/year),  $P_{TP}$  is the technical power potential (MW),  $CF$  is Study Area Capacity factor (%), and  $T_{TSH}$  is the hours of the whole year (8,760 hours/year).

---

## Potential Site and Electricity Generation Potential

### Solar PV Potential Sites and Mapping

Figure 14 presents the map of solar PV potential suitable sites evaluated for Zambia, which indicates that the country has large land areas suitable for solar PV power plant development both at district and provincial levels. The aim of this case was focused on mapping the potential sites suitable for PV power plant installation with minimized or no environmental and social impacts. Therefore, all limiting factors considered not suitable for PV systems and those areas likely to have environmental and social issues were eliminated in the analysis using GIS spatial analysis. Hence, the Solar PV Potential Sites atlas shows that the country has the largest suitable site for solar PV power plant development in the Southern Province with Lusaka Province having the least. However, it can be observed that the available suitable areas are distributed throughout the country, hence providing opportunity for wide deployment of the solar PV technologies across the country. In addition, the atlas also shows that regions near to the national power grid contain suitable sites for easy integration of these technologies into the national energy mix and national power grid. The atlas provides essential information for sites close to villages and towns far from the grid offering opportunity for mini off-grid systems. Therefore, the atlas offers vital information for setting targets for electrification of both rural and urban areas of the country.

### Available Suitable Land Area

Table 5 shows the annual average solar irradiation, total surface area and the available suitable areas for each district of Zambia. This reveals significant differences in suitable available areas within the 75 districts and 9 provinces across the country due to the availability of the aforementioned restricting factors considered in the evaluation. It can be observed that the districts in Eastern Province have lowest ratios of suitable area to surface areas in the ranges of 1.57 to 11.61% mainly due to the availability of restricting factors such as escapement, protected areas (e.g., National Parks, Zones of higher Agriculture Potential), and agriculture activities.



**Fig. 14** Potential suitable sites for utility-scale solar PV power plant deployment

The provincial total suitable areas available for utility-scale solar photovoltaic power plants development as shown in Table 6 ranged from 2,151.70 km<sup>2</sup> (Lusaka) to 16,593.56 km<sup>2</sup> (Southern). As earlier stated, Eastern Province has the lowest annual average solar irradiation and also the overall percent suitable area (6.61%) whereas Southern Province has the largest (19.33%). However, Lusaka Province due to its size and population has the lowest overall suitable area (2,151.70 km<sup>2</sup>) followed by Copperbelt (4,475.66 km<sup>2</sup>) and highest being the Southern Province

**Table 5** Available suitable areas in the districts of Zambia

Province	Districts	Coordinates		Annual solar irradiation	Total surface area	Percentage suitable area	Total suitable area	
	Sites	S (°)	E (°)	(kWh/m <sup>2</sup> -day)	(km <sup>2</sup> )	(%)	(km <sup>2</sup> )	
Eastern	Chama	11.216	33.162	5.79	18,152	8.07	1,464.8664	
	Chipata	13.641	32.646	5.78	6,172	1.71	105.5412	
	Chadiza	14.061	32.417	5.58	2,541	4.72	119.9352	
	Petauke	14.248	31.322	5.65	8,495	11.61	986.2695	
	Katete	14.051	32.047	5.59	3,969	6.86	272.2734	
	Lundazi	12.281	33.173	5.65	13,517	1.57	212.2169	
	Nyimba	14.557	30.822	5.69	10,444	10.41	1,087.2204	
	Mambwe	13.550	31.756	5.71	5,918	5.47	323.7146	
	-	-	-	-	<b>69,208</b>	<b>6.61</b>	<b>4,572.0376</b>	
	Total	-	-	-	-	-	-	-
Lusaka	Chongwe	15.336	28.670	5.72	11,728	11.45	1,342.856	
	Kafue	15.765	28.181	5.72	5,658	10.39	587.8662	
	Luangwa	15.305	30.037	5.64	4,062	5.00	203.1000	
	Lusaka	15.403	28.287	5.72	447	4.00	17.8800	
	-	-	-	-	<b>21,896</b>	<b>9.83</b>	<b>2,151.7022</b>	
	Total	-	-	-	-	-	-	
	Southern	Choma	16.805	27.004	5.71	7,010	18.54	1,299.654
		Gwembwe	16.494	27.598	5.71	4,048	11.81	478.0688
		Itezhi-tezhi	15.734	26.054	5.83	16,310	23.78	3,878.518
		Kalomo	17.025	26.477	5.80	13,808	22.71	3,135.7968
Kazungula		17.550	25.425	5.92	18,375	23.78	4,369.575	
Livingstone		17.843	25.840	5.92	755	12.16	91.8080	
Mazabuka		15.856	27.751	5.83	6,432	17.30	1,112.736	
Monze		16.278	27.488	5.71	4,685	14.47	677.9195	
Namwala		15.739	26.455	5.83	5,216	5.16	269.1456	
Siavonga		16.502	28.746	5.75	4,284	17.31	741.5604	
Sinazongwe	17.220	27.477	5.77	4,898	11.00	538.7800		

(continued)



Table 5 (continued)

Province	Districts	Coordinates	Annual solar irradiation	Total surface area	Percentage suitable area	Total suitable area
<b>Total</b>	-	-	-	<b>85,823</b>	<b>19.33</b>	<b>16,593,5621</b>
Luapula	Chieng	8.653	29.166	3,391	5.77	195,6607
	Kawambwa	9.800	29.078	9,651	8.67	836,7417
	Mansa	11.197	28.893	10,096	23.77	2,399,8192
	Milenge	12.082	29.295	5,930	9.64	571,6520
	Mwense	10.392	28.666	6,654	11.80	785,1720
	Nchelenge	9.361	28.742	3,632	7.46	270,9472
	Samfya	11.353	29.491	5.80	8.98	1,006,9274
	<b>Total</b>	-	-	-	<b>50,567</b>	<b>11.998</b>
North Western	Chavuma	13.079	22.681	4,434	47.17	2,091,5178
	Kabompo	13.593	24.203	14,295	6.15	879,1425
	Kasempa	13.459	25.840	22,061	4.28	944,2108
	Mufumbwe	13.678	24.796	19,734	4.12	813,0408
	Mwinilunga	11.738	24.428	21,191	4.26	902,7366
	Solvezi	12.168	26.384	30,232	6.44	1,946,9408
	Zambezi	13.539	23.115	13,879	28.37	3,937,4723
	<b>Total</b>	-	-	-	<b>125,826</b>	<b>9.15</b>
Available suitable areas in the districts of Zambia						
Province	Districts	Coordinates	Solar irradiation	Total surface area	Percentage suitable area	Total suitable area
Northern	-	S(°)	E(°)	(km <sup>2</sup> )	(%)	(km <sup>2</sup> )
	Chinsali	10.542	32.080	14,939	4.12	615,4868
	Chilubi	11.073	30.130	5,187	3.58	185,6946
	Isoka	10.150	32.660	9,344	5.05	471,8720
	Kaputa	8.472	29.662	5.67	16.16	2,075,4288
	Kasama	10.201	31.193	5.88	10.86	1,150,0740
	Luwingu	10.250	29.916	5.73	11.96	1,043,0316

Mbala	8.847	31.371	5.77	8.662	11.37	984.8694
Mpika	11.824	31.440	5.83	40,025	6.38	2,553.5950
Mporokoso	9.373	30.125	5.75	12,028	12.44	1,496.2832
Mpulungu	8.771	31.124	5.77	10,351	7.53	779.4303
Mungwi	9.609	32.212	5.84	10,051	8.37	841.2687
Nakonde	9.354	32.723	5.84	4,445	18.45	820.1025
<b>Total</b>	-	-	-	<b>147,186</b>	<b>8.84</b>	<b>13,017.1369</b>
Central	14.703	28.106	5.80	13,298	10.50	1,396.2900
Kabwe	14.435	28.435	5.80	1,594	5.95	94.8430
Kapiri-Mposhi	13.955	28.674	5.80	12,120	13.11	1,588.9320
Mkushi	13.995	29.474	5.72	22,552	8.06	1,817.6912
Mumbwa	15.006	27.059	5.83	21,755	10.59	2,303.8545
Serenje	13.253	30.284	5.62	23,075	12.35	2,849.7625
<b>Total</b>	-	-	-	<b>94,394</b>	<b>10.65</b>	<b>10,051.3732</b>
Copperbelt	12.353	27.834	5.70	938	15.00	140.7000
Chingola	12.538	27.837	5.70	1,766	13.95	246.3570
Kalulushi	12.844	28.026	5.74	1,121	16.00	179.3600
Kitwe	12.809	28.216	5.74	889	21.67	192.6463
Luanshya	13.152	28.413	5.80	950	16.22	154.0900
Lufwanyama	12.678	27.279	5.70	11,316	11.05	1,250.4180
Masaiti	13.280	28.408	5.80	3,703	19.73	730.6019
Mpongwe	13.529	28.144	5.82	8,465	14.71	1,245.2015
Mufulira	12.557	28.240	5.74	1,145	15.91	182.1695
Ndola	12.980	28.628	5.74	1,035	14.89	154.1115

(continued)

**Table 5** (continued)

Province	Districts	Coordinates	Annual solar irradiation	Total surface area	Percentage suitable area	Total suitable area
<b>Total</b>	-	-	-	<b>31,328</b>	<b>14.29</b>	<b>4,475,6557</b>
Western	Kalabo	14,998	5,86	18,065	23.49	4,243,4685
	Kaoma	14,817	5,85	22,099	4.90	1,082,8510
	Lukulu	14,408	5,89	15,589	21.09	3,287,7201
	Mongu	15,274	5,90	10,125	4.00	405,0000
	Senanga	16,120	5,93	15,205	9.53	1,449,0365
	Sesheke	16,747	5,91	29,423	6.97	2,050,7831
	Shang'ombo	16,317	5,92	15,880	10.09	1,602,2920
<b>Total</b>	-	-	-	<b>126,386</b>	<b>11.17</b>	<b>14,121,1512</b>

**Table 6** Provincial total suitable areas for utility-scale solar photovoltaic power plants

Province	Annual solar irradiation (kWh/m <sup>2</sup> -day)	Total area (km <sup>2</sup> )	Suitable area (km <sup>2</sup> )	Percent suitable area (%)
Lusaka	5.70	21,896	2,151.7022	9.82
Luapula	5.78	50,567	6,066.9202	12.00
Central	5.76	94,394	10,051.3732	10.65
Copperbelt	5.75	31,328	4,475.6557	14.29
Northern	5.83	147,186	13,017.1369	8.84
N/Western	5.74	125,826	11,515.0616	9.15
Western	5.89	126,386	14,121.1512	11.17
Southern	5.80	85,823	16,593.5621	19.33
Eastern	5.68	69,208	4,572.0376	6.61
Zambia	<b>5.78</b>	<b>752,614</b>	<b>82,564.6007</b>	<b>10.97</b>

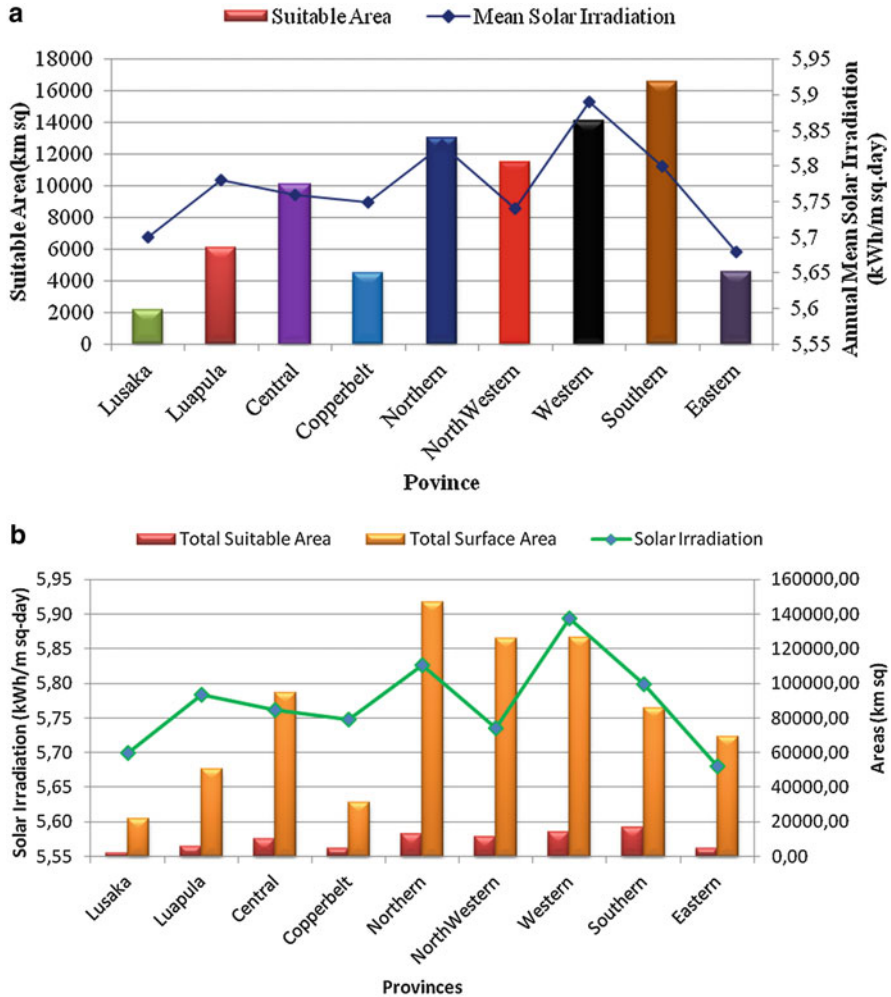
(16,593.56 km<sup>2</sup>) (Fig. 15a, b). In short, comparing only available suitable areas where installation of PV system is suitable, Southern province has about 7.71 times more suitable area than Lusaka Province. However, there are large differences in surface area size between the two provinces, with Lusaka having 3.92 times less surface area than Southern Province. The country has approximately 10.97% equivalent to 82,564.60 km<sup>2</sup> of the total suitable surface land area for development of utility-scale solar PV power plant (Table 6).

## Electrical Power and Electricity Generation Potential

Table 7 shows district solar energy theoretical and geographical energy potential. Since these potentials depend on the solar irradiation and available surface area and available geographical suitable areas. Hence areas with larger surfaces and receiving the higher solar irradiation such as Northern, Western, and North-Western have the highest overall theoretical potential whereas areas with larger suitable areas such as Southern, Western, Northern, North-Western, and Central Provinces have higher geographical solar energy potential (Table 8 and Fig. 16).

The district-based solar PV technical power potential by technology (Table 9) shows that crystalline silicon based solar PV technologies possess large potential due to less land requirements for installation, with monocrystalline-silicon technology having the largest technical power potential of 5,897.46 GW whereas amorphous-silicon having the lowest potential of 2,752.16 GW due to huge land requirements. The variation in power potential per district is highly depended on the available suitable areas in each district which is as a result of local geographical and terrain features.

The provincial solar PV technical power potential per technology (Table 10 and Fig. 17) shows that Southern Province, followed by Western have the highest potential and Lusaka Province being the lowest. Figure 18 shows the comparison



**Fig. 15** (a) Provincial total suitable areas for utility-scale solar photovoltaic power plants. (b) Comparison of provincial total surface areas and suitable areas for utility-scale solar photovoltaic power plants

of solar PV technologies peak power potential for Zambia, with monocrystalline silicon having the largest whereas amorphous silicon having the lowest potential.

In absolute numbers, the highest electricity generation can be generated in the Southern, Western, Northern, North-Western, and Central Provinces due to large available suitable land areas for utility-scale solar PV system development (Table 12 and Fig. 19). Table 11 illustrates the district solar PV technical electricity generation potential by technology. Just like technical power potential it can be observed that districts with large suitable areas have the largest electricity generation potential.

**Table 7** District solar energy theoretical and geographical potential

Province	Districts	Annual solar irradiation (kWh/m <sup>2</sup> -day)	Total surface area (km <sup>2</sup> )	Total suitable area (km <sup>2</sup> )	Theoretical potential (TWh/year)	Geographical potential (TWh/year)
Eastern	Sites					
	Chama	5.79	18,152	1,464.8664	38,361.53	3,095.78
	Chipata	5.78	6,172	105.5412	13,021.07	222.66
	Chadiza	5.58	2,541	119.9352	5,175.25	244.27
	Petauke	5.65	8,495	986.2695	17,518.81	2033.93
	Katete	5.59	3,969	272.2734	8,098.15	555.53
	Lundazi	5.65	13,517	212.2169	27,875.43	437.64
	Nyimba	5.69	10,444	1,087.2204	21,690.62	2,257.99
	Mambwe	5.71	5,918	323.7146	12,334.00	674.67
	<b>Total</b>			<b>69,208</b>	<b>4,572.0376</b>	<b>143,482.03</b>
Lusaka	Chongwe	5.72	11,728	1,342.856	24,485.72	2,803.61
	Kafue	5.72	5,658	587.8662	11,812.77	1,227.35
	Luangwa	5.64	4,062	203.1000	8,362.03	418.10
	Lusaka	5.72	447	17.8800	933.25	37.33
	<b>Total</b>			<b>21,896</b>	<b>2,151.7022</b>	<b>45,554.63</b>
Southern	Choma	5.71	7,010	1,299.654	14,609.89	2,708.67
	Gwembwe	5.71	4,048	478.0688	8436.64	996.37
	Itezhi-tezhi	5.83	16,310	3,878.518	34,706.86	8,253.29
	Kalomo	5.80	13,808	3,135.7968	29,231.54	6,638.48
	Kazungula	5.92	18,375	4,369.575	39,704.70	9,441.78
	Livingstone	5.92	755	91.8080	1,631.40	198.38
	Mazabuka	5.83	6,432	1,112.736	13,686.97	2,367.85
	Monze	5.71	4,685	677.9195	9,764.24	1,412.89
	Namwala	5.83	5,216	269.1456	11,099.39	572.73
	Siavonga	5.75	4,284	741.5604	8,991.05	1,556.35
	Sinazongwe	5.77	4,898	538.7800	10,315.43	1,134.70

(continued)

Table 7 (continued)

Province	Districts	Annual solar irradiation	Total surface area	Total suitable area	Theoretical potential	Geographical potential
<b>Total</b>			<b>85,823</b>	<b>16,593,5621</b>	<b>181,630.34</b>	<b>35,117.56</b>
Luapula	Chienge	5.67	3,391	195,6607	7,017.84	404.93
	Kawambwa	5.78	9,651	836,7417	20,360.71	1,765.27
	Mansa	5.76	10,096	2,399,8192	21,225.83	5,045.38
	Milenge	6.23	5,930	571,6520	13,484.52	1,299.91
	Mwense	5.63	6,654	785,1720	13,673.64	1,613.49
	Nchelenge	5.62	3,632	270,9472	7,450.32	555.79
	Samfya	5.80	11,213	1,006,9274	23,737.92	2,131.67
	<b>Total</b>		<b>50,567</b>	<b>6,066,9202</b>	<b>106,760.30</b>	<b>12,808.87</b>
North Western	Chavuma	5.81	4,434	2,091,5178	9,402.96	4,435.38
	Kabompo	5.79	14,295	879,1425	30,210.34	1,857.94
	Kasempa	5.80	22,061	944,2108	46,703.14	1,998.89
	Mufumbwe	5.84	19,734	813,0408	42,064.99	1,733.08
	Mwinilunga	5.51	21,191	902,7366	42,618.28	1,815.54
	Solwezi	5.60	30,232	1,946,9408	61,794.21	3,979.55
	Zambezi	5.80	13,879	3,937,4723	29,381.84	8,335.63
	<b>Total</b>		<b>125,826</b>	<b>11,515,0616</b>	<b>263,421.22</b>	<b>24,107.19</b>
Northern	Districts	Solar irradiation	Total surface area	Total suitable area	Theoretical potential	Geographical potential
		(kWh/m <sup>2</sup> -day)	(km <sup>2</sup> )	(km <sup>2</sup> )	(TWh/year)	(TWh/year)
	Chinsali	5.90	14,939	615,4868	32,171.14	1,325.45
	Chilubi	6.04	5,187	185,6946	11,435.26	409.38
	Isoka	5.90	9,344	471,8720	20,122.30	1,016.18
	Kaputa	5.67	12,843	2,075,4288	26,579.23	4,295.20
	Kasama	5.88	10,590	1,150,0740	22,728.26	2,468.29
	Luwingu	5.73	8,721	1,043,0316	18,239.54	2,181.45
	Mbala	5.77	8,662	984,8694	18,242.61	2,074.18

Mpika	5.83	40,025	2,553.5950	85,171.20	5,433.92
Mporokoso	5.75	12,028	1,496.2832	25,243.77	3,140.32
Mpulungu	5.77	10,351	779.4303	21,799.72	1,641.52
Mungwi	5.84	10,051	841.2687	21,424.71	1,793.25
Nakonde	5.84	4,445	820.1025	9,474.96	1,748.13
<b>Total</b>		<b>147,186</b>	<b>13,017.1369</b>	<b>313,025.37</b>	<b>27,683.98</b>
Central	5.80	13,298	1,396.2900	28,151.87	2,955.95
Kabwe	5.80	1,594	94.8430	3,374.50	200.78
Kapiri-Mposhi	5.80	12,120	1,588.9320	25,658.04	3,363.77
Mkushi	5.72	22,552	1,817.6912	47,084.07	3,794.98
Mumbwa	5.83	21,755	2,303.8545	46,293.55	4,902.49
Serenje	5.62	23,075	2,849.7625	47,333.75	5,845.72
<b>Total</b>		<b>94,394</b>	<b>10,051.3732</b>	<b>198,511.37</b>	<b>21,138.12</b>
Copperbelt	5.70	938	140.7000	1,951.51	292.73
Chililabombwe	5.70	1,766	246.3570	3,674.16	512.55
Chingola	5.74	1,121	179.3600	2,348.61	375.78
Kitwe	5.74	889	192.6463	1,862.54	403.61
Luanshya	5.80	950	154.0900	2,011.15	326.21
Lufwanyama	5.70	11,316	1,250.4180	23,542.94	2,601.49
Masaiti	5.80	3,703	730.6019	7,839.25	1,546.68
Mpongwe	5.82	8,465	1,245.2015	17,982.20	2,645.18
Mufulira	5.74	1,145	182.1695	2,398.89	381.66
Ndola	5.74	1,035	154.1115	2,168.43	322.88

(continued)



**Table 7** (continued)

Province	Districts	Annual solar irradiation	Total surface area	Total suitable area	Theoretical potential	Geographical potential
<b>Total</b>			<b>31,328</b>	<b>4,475.6557</b>	<b>65,726.77</b>	<b>9,390.02</b>
Western	Kalabo	5.86	18,065	4,243.4685	38,639.23	9,076.35
	Kaoma	5.85	22,099	1,082.8510	47,186.89	2,312.16
	Lukulu	5.89	15,589	3,287.7201	33,514.01	7,068.11
	Mongu	5.90	10,125	405.0000	21,804.19	872.17
	Senanga	5.93	15,205	1,449.0365	32,910.46	3,136.37
	Sesheke	5.91	29,423	2,050.7831	63,469.82	4,423.85
	Shang'ombo	5.92	15,880	1,602.2920	34,313.50	3,462.23
<b>Total</b>			<b>126,386</b>	<b>14,121.1512</b>	<b>271,908.65</b>	<b>30,380.45</b>

**Table 8** Provincial solar energy theoretical and geographical potential

Province	Annual average solar irradiation (kWh/m <sup>2</sup> -day)	Total surface area (km <sup>3</sup> )	Total suitable area (km <sup>2</sup> )	Theoretical energy potential (TWh/year)	Geographical energy potential (TWh/year)
Lusaka	5.70	21,896.00	2,151.70	45,554.63	4,476.62
Luapula	5.78	50,567.00	6,066.92	106,760.30	12,808.87
Central	5.76	94,394.00	10,051.37	198,511.37	21,138.12
Copperbelt	5.75	31,328.00	4,475.66	65,726.77	9,390.02
Northern	5.83	147,186.00	13,017.14	313,025.37	27,683.98
Northwestern	5.74	125,826.00	11,515.06	263,421.22	24,107.19
Western	5.89	126,386.00	14,121.15	271,908.65	30,380.45
Southern	5.80	85,823.00	16,593.56	181,630.34	35,117.56
Eastern	5.68	69,208.00	45,720.38	143,482.03	9,478.75
Zambia	5.77	752,614.00	82,564.60	1,590,020.67	174,581.55

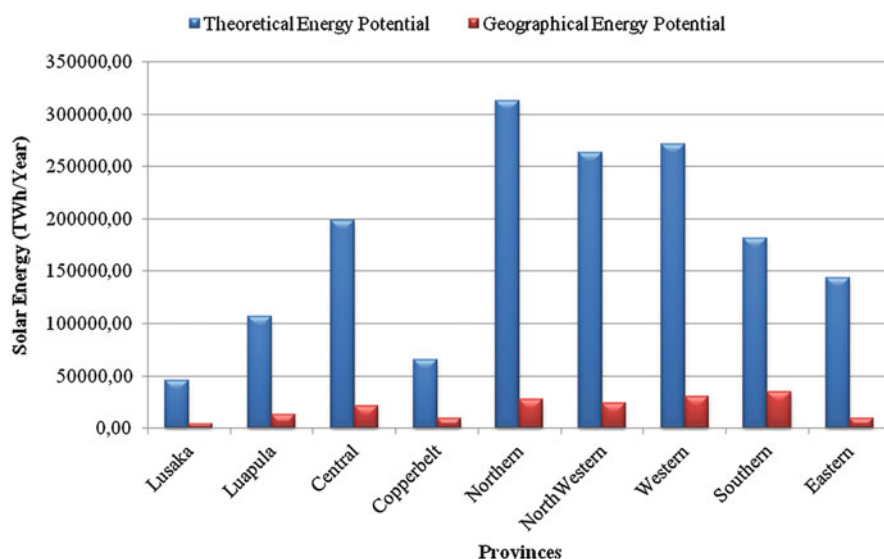
**Fig. 16** Provincial solar energy theoretical and geographical potential

Table 12 and Fig. 19 show that Southern Province, followed by Western Province have the highest potential while Lusaka province has the lowest potential for electricity generation from solar PV based technologies due to aforementioned issues. Figure 20 shows a comparison of the provincial theoretical and geographical solar energy potential and the technical solar electricity potential. It is worth noting that due to technical characteristic of the solar cell technologies and land requirements the technical solar electricity generation potential is lower as compared to the solar energy received on these potential sites. Hence, this presents the need to select

**Table 9** District solar PV technical power potential by technology

Province	Districts	Technical power potential (GW)				
		mc-Si	pc-Si	a-Si	CIS	CdTe
Eastern	Chama	104.63	91.55	48.83	73.24	66.58
	Chipata	7.54	6.60	3.52	5.28	4.80
	Chadiza	8.57	7.50	4.00	6.00	5.45
	Petauke	70.45	61.64	32.88	49.31	44.83
	Katete	19.45	17.02	9.08	13.61	12.38
	Lundazi	15.16	13.26	7.07	10.61	9.65
	Nyimba	77.66	67.95	36.24	54.36	49.42
	Mambwe	23.12	20.23	10.79	16.19	14.71
<b>Total</b>	-	<b>326.57</b>	<b>285.75</b>	<b>152.40</b>	<b>228.60</b>	<b>207.82</b>
Lusaka	Chongwe	95.92	83.93	44.76	67.14	61.04
	Kafue	41.99	36.74	19.60	29.39	26.72
	Luangwa	14.51	12.69	6.77	10.16	9.23
	Lusaka	1.28	1.12	0.60	0.89	0.81
<b>Total</b>	-	<b>153.69</b>	<b>134.48</b>	<b>71.72</b>	<b>107.59</b>	<b>97.80</b>
Southern	Choma	92.83	81.23	43.32	64.98	59.08
	Gwembwe	34.15	29.88	15.94	23.90	21.73
	Itezhi-tezhi	277.04	242.41	129.28	193.93	176.30
	Kalomo	223.99	195.99	104.53	156.79	142.54
	Kazungula	312.11	273.10	145.65	218.48	198.62
	Livingstone	6.56	5.74	3.06	4.59	4.17
	Mazabuka	79.48	69.55	37.09	55.64	50.58
	Monze	48.42	42.37	22.60	33.90	30.81
	Namwala	19.22	16.82	8.97	13.46	12.23
	Siavonga	52.97	46.35	24.72	37.08	33.71
Sinazongwe	38.48	33.67	17.96	26.94	24.49	
<b>Total</b>	-	<b>1,185.25</b>	<b>1,037.10</b>	<b>553.12</b>	<b>829.68</b>	<b>754.25</b>
Luapula	Chienge	13.98	12.23	6.52	9.78	8.89
	Kawambwa	59.77	52.30	27.89	41.84	38.03
	Mansa	171.42	149.99	79.99	119.99	109.08
	Milenge	40.83	35.73	19.06	28.58	25.98
	Mwense	56.08	49.07	26.17	39.26	35.69
	Nchelenge	19.35	16.93	9.03	13.55	12.32
	Samfya	71.92	62.93	33.56	50.35	45.77
<b>Total</b>	-	<b>433.35</b>	<b>379.18</b>	<b>202.23</b>	<b>303.35</b>	<b>275.77</b>
North Western	Chavuma	149.39	130.72	69.72	104.58	95.07
	Kabompo	62.80	54.95	29.30	43.96	39.96
	Kasempa	67.44	59.01	31.47	47.21	42.92
	Mufumbwe	58.07	50.82	27.10	40.65	36.96
	Mwinilunga	64.48	56.42	30.09	45.14	41.03
	Solwezi	139.07	121.68	64.90	97.35	88.50
Zambezi	281.25	246.09	131.25	196.87	178.98	
<b>Total</b>	-	<b>822.50</b>	<b>719.69</b>	<b>383.84</b>	<b>575.75</b>	<b>523.41</b>

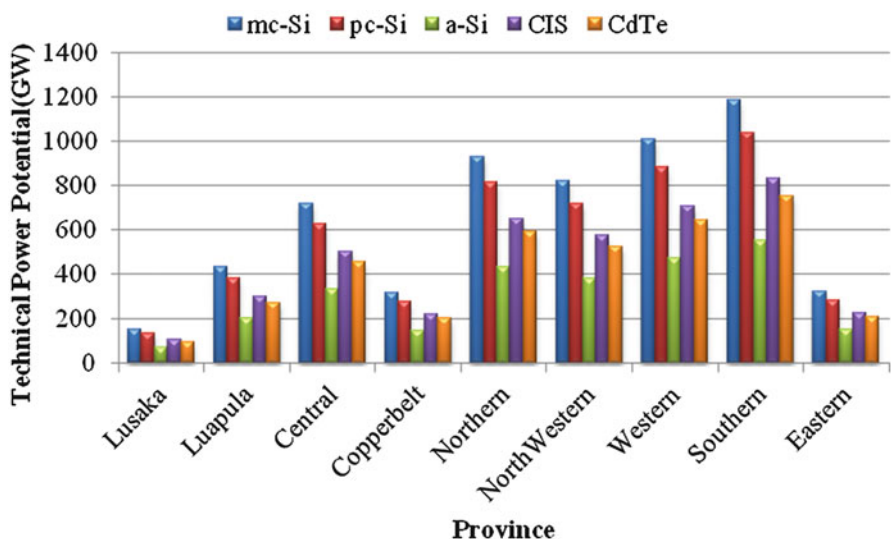
(continued)

**Table 9** (continued)

Province	Districts	Technical power potential (GW)				
		mc-Si	pc-Si	a-Si	CIS	CdTe
Province	Districts	Technical power potential (GW)				
		Mc-Si	Pc-Si	a-Si	CIS	CdTe
Northern	Chinsali	43.96	38.47	20.52	30.77	27.98
	Chilubi	13.26	11.61	6.19	9.28	8.44
	Isoka	33.71	29.49	15.73	23.59	21.45
	Kaputa	148.24	129.71	69.18	103.77	94.34
	Kasama	82.15	71.88	38.34	57.50	52.28
	Luwingu	74.50	65.19	34.77	52.15	47.41
	Mbala	70.35	61.55	32.83	49.24	44.77
	Mpika	182.40	159.60	85.12	127.68	116.07
	Mporokoso	106.88	93.52	49.88	74.81	68.01
	Mpulungu	55.67	48.71	25.98	38.97	35.43
	Mungwi	60.09	52.58	28.04	42.06	38.24
	Nakonde	58.58	51.26	27.34	41.01	37.28
Total	-	<b>929.80</b>	<b>813.57</b>	<b>433.90</b>	<b>650.86</b>	<b>591.69</b>
Central	Chibombo	99.74	87.27	46.54	69.81	63.47
	Kabwe	6.77	5.93	3.16	4.74	4.31
	Kapiri-Mposhi	113.50	99.31	52.96	79.45	72.22
	Mkushi	129.84	113.61	60.59	90.88	82.62
	Mumbwa	164.56	143.99	76.80	115.19	104.72
	Serenje	203.55	178.11	94.99	142.49	129.53
Total	-	<b>717.96</b>	<b>628.21</b>	<b>335.05</b>	<b>502.57</b>	<b>456.88</b>
Copperbelt	Chililabombwe	10.05	8.79	4.69	7.04	6.40
	Chingola	17.60	15.40	8.21	12.32	11.20
	Kalulushi	12.81	11.21	5.98	8.97	8.15
	Kitwe	13.76	12.04	6.42	9.63	8.76
	Luanshya	11.01	9.63	5.14	7.70	7.00
	Lufwanyama	89.32	78.15	41.68	62.52	56.84
	Masaiti	52.19	45.66	24.35	36.53	33.21
	Mpongwe	88.94	77.83	41.51	62.26	56.60
	Mufulira	13.01	11.39	6.07	9.11	8.28
	Ndola	11.01	9.63	5.14	7.71	7.01
Total	-	<b>319.69</b>	<b>279.73</b>	<b>149.19</b>	<b>223.78</b>	<b>203.44</b>
Western	Kalabo	303.10	265.22	141.45	212.17	192.88
	Kaoma	77.35	67.68	36.10	54.14	49.22
	Lukulu	234.84	205.48	109.59	164.39	149.44
	Mongu	28.93	25.31	13.50	20.25	18.41
	Senanga	103.50	90.56	48.30	72.45	65.87
	Sesheke	146.48	128.17	68.36	102.54	93.22
	Shang'ombo	114.45	100.14	53.41	80.11	72.83
Total	-	<b>1,008.65</b>	<b>882.57</b>	<b>470.71</b>	<b>706.06</b>	<b>641.87</b>

**Table 10** Provincial solar PV technical power potential per technology

Province	Technical Power Potential (GW)				
	mc-Si	pc-Si	a-Si	CIS	CdTe
Lusaka	153.69	134.48	71.72	107.59	97.80
Luapula	433.35	379.18	202.23	303.35	275.77
Central	717.96	628.21	335.05	502.57	456.88
Copperbelt	319.69	279.73	149.19	223.78	203.44
Northern	929.80	813.57	433.90	650.86	591.69
North-Western	822.50	719.69	383.84	575.75	523.41
Western	1,008.65	882.57	470.71	706.06	641.87
Southern	1,185.25	1,037.10	553.12	829.68	754.25
Eastern	326.57	285.75	152.40	228.60	207.82
Zambia	<b>5,897.46</b>	<b>5,160.28</b>	<b>2,752.16</b>	<b>4,128.24</b>	<b>3,752.93</b>

**Fig. 17** Provincial solar PV technical power potential per technology

suitable solar cell technology for application in the solar energy harvesting systems for optimal solar energy utilization.

Figure 21 shows the comparison of solar PV technologies for electricity generation potential for Zambia considering the available suitable areas and the technology characteristics. It is observed that monocrystalline provides the highest electricity generation potential followed by polycrystalline and least amorphous. This is mainly due to the differences in amount of land area requirements for the same peak power and the ability of the technology to convert the solar energy into electrical energy (efficiency).

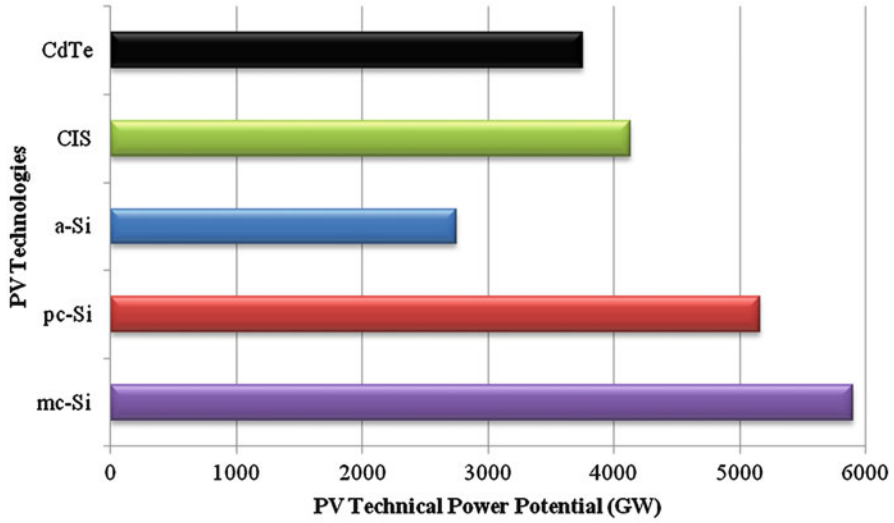


Fig. 18 Comparison of solar PV technical power potential per technology of Zambia

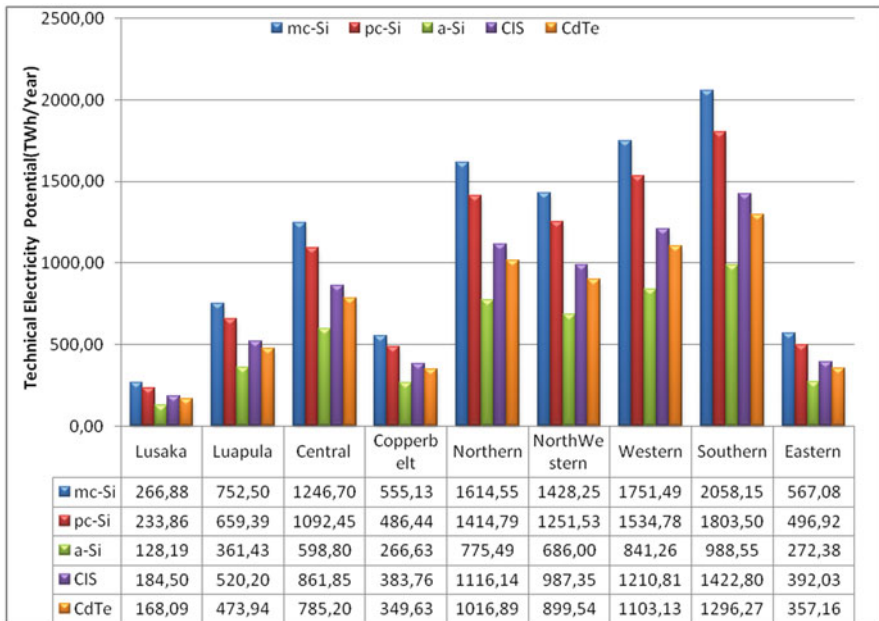


Fig. 19 Provincial solar PV technical electricity generation potential

**Table 11** District solar PV technical electricity generation potential by technology

Province	Districts sites	Technical electricity generation potential (TWh/Year)				
		Solar PV technologies				
		mc-Si	pc-Si	a-Si	CIS	CdTe
Eastern	Chama	181.69	159.21	87.27	125.60	114.43
	Chipata	13.09	11.47	6.29	9.05	8.24
	Chadiza	14.88	13.04	7.15	10.28	9.37
	Petauke	122.33	107.19	58.76	84.57	77.05
	Katete	33.77	29.59	16.22	23.35	21.27
	Lundazi	26.32	23.07	12.64	18.20	16.58
	Nyimba	134.85	118.17	64.77	93.22	84.93
	Mambwe	40.15	35.18	19.29	27.76	25.29
Total	-	<b>567.08</b>	<b>496.92</b>	<b>272.38</b>	<b>392.03</b>	<b>357.16</b>
Lusaka	Chongwe	166.56	145.95	80.00	115.14	104.90
	Kafue	72.91	63.89	35.02	50.41	45.92
	Luangwa	25.19	22.07	12.10	17.41	15.87
	Lusaka	2.22	1.94	1.07	1.53	1.40
Total	-	<b>266.88</b>	<b>233.86</b>	<b>128.19</b>	<b>184.50</b>	<b>168.09</b>
Southern	Choma	161.20	141.25	77.43	111.44	101.53
	Gwembwe	59.30	51.96	28.48	40.99	37.35
	Itezhi-tezhi	481.06	421.54	231.06	332.56	302.99
	Kalomo	388.94	340.82	186.81	268.88	244.97
	Kazungula	541.97	474.91	260.31	374.67	341.35
	Livingstone	11.39	9.98	5.47	7.87	7.17
	Mazabuka	138.02	120.94	66.29	95.41	86.93
	Monze	84.08	73.68	40.39	58.13	52.96
	Namwala	33.38	29.25	16.03	23.08	21.03
	Siavonga	91.98	80.60	44.18	63.58	57.93
Sinazongwe	66.83	58.56	32.10	46.20	42.09	
Total	-	<b>2,058.15</b>	<b>1,803.50</b>	<b>988.55</b>	<b>1,422.80</b>	<b>1,296.27</b>
Luapula	Chienge	24.27	21.27	11.66	16.78	15.28
	Kawambwa	103.78	90.94	49.85	71.75	65.37
	Mansa	297.66	260.83	142.97	205.77	187.47
	Milenge	70.90	62.13	34.06	49.02	44.66
	Mwense	97.39	85.34	46.78	67.32	61.34
	Nchelenge	33.61	29.45	16.14	23.23	21.17
	Samfya	124.89	109.44	59.99	86.34	78.66
Total	-	<b>752.50</b>	<b>659.39</b>	<b>361.43</b>	<b>520.20</b>	<b>473.94</b>
Northwestern	Chavuma	259.42	227.32	124.60	179.34	163.39
	Kabompo	109.04	95.55	52.37	75.38	68.68
	Kasempa	117.11	102.62	56.25	80.96	73.76
	Mufumbwe	100.84	88.37	48.44	69.71	63.51
	Mwinilunga	111.97	98.12	53.78	77.40	70.52
	Solwezi	241.48	211.61	115.99	166.94	152.09
	Zambezi	488.38	427.95	234.57	337.62	307.59
Total	-	<b>1,428.25</b>	<b>1,251.53</b>	<b>686.00</b>	<b>987.35</b>	<b>899.54</b>

(continued)

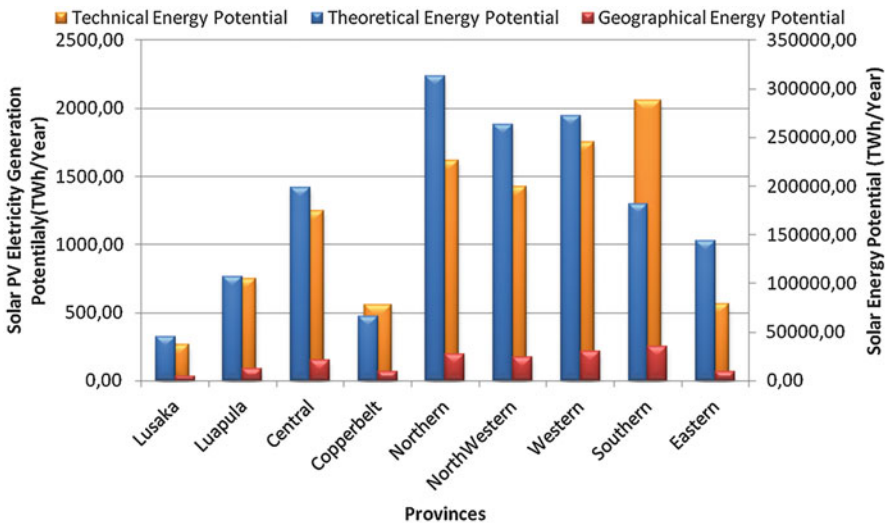
**Table 11** (continued)

Province	Districts sites	Technical electricity generation potential (TWh/Year)				
		Solar PV technologies				
		mc-Si	pc-Si	a-Si	CIS	CdTe
Northern	Chinsali	76.34	66.90	36.67	52.77	48.08
	Chilubi	23.03	20.18	11.06	15.92	14.51
	Isoka	58.53	51.29	28.11	40.46	36.86
	Kaputa	257.42	225.57	123.64	177.96	162.13
	Kasama	142.65	125.00	68.51	98.61	89.84
	Luwingu	129.37	113.36	62.14	89.43	81.48
	Mbala	122.116	107.04	58.67	84.45	76.94
	Mpika	316.173	277.54	152.13	218.96	199.48
	Mporokoso	1851.59	162.63	89.14	128.30	116.89
	Mpulungu	96.168	84.71	46.43	66.83	60.89
	Mungwi	104.35	91.43	50.12	72.13	65.72
Nakonde	101.72	89.13	48.86	70.32	64.07	
Total	-	<b>1,614.55</b>	<b>1,414.79</b>	<b>775.49</b>	<b>1,116.14</b>	<b>1,016.89</b>
Province	Districts	Technical electricity generation potential (TWh/year)				
		Solar PV technologies				
	Sites	Mc-Si	Pc-Si	a-Si	CIS	CdTe
Central	Chibombo	173.19	151.76	83.18	119.72	109.08
	Kabwe	11.76	10.31	5.65	8.13	7.41
	Kapiri-Mposhi	197.08	172.70	94.66	136.24	124.13
	Mkushi	225.45	197.56	108.29	155.86	142.00
	Mumbwa	285.75	250.40	137.25	197.54	179.97
	Serenje	353.46	309.73	169.77	244.35	222.62
Total	-	<b>1,246.70</b>	<b>1,092.45</b>	<b>598.80</b>	<b>861.85</b>	<b>785.20</b>
Copperbelt	Chililabombwe	17.45	15.29	8.38	12.06	10.99
	Chingola	30.56	26.78	14.68	21.12	19.25
	Kalulushi	22.25	19.49	10.69	15.38	14.01
	Kitwe	23.89	20.94	11.48	16.52	15.05
	Luanshya	19.11	16.75	9.18	13.21	12.04
	Lufwanyama	155.09	135.90	74.49	107.22	97.68
	Masaiti	90.62	79.41	43.53	62.64	57.07
	Mpongwe	154.45	135.34	74.18	106.77	97.27
	Mufulira	22.60	19.80	10.85	15.62	14.23
Ndola	19.11	16.75	9.18	13.21	12.04	
Total	-	<b>555.13</b>	<b>486.44</b>	<b>266.63</b>	<b>383.76</b>	<b>349.63</b>
Western	Kalabo	526.33	461.21	252.80	363.85	331.50
	Kaoma	134.31	117.69	64.51	92.85	84.59
	Lukulu	407.79	357.33	195.86	281.90	256.83
	Mongu	50.23	44.02	24.13	34.73	31.64
	Senanga	179.73	157.49	86.33	124.25	113.20
	Sesheke	254.36	222.89	122.17	175.84	160.21
	Shang'ombo	198.74	174.15	95.46	137.39	125.17
	-	<b>1,751.49</b>	<b>1,534.78</b>	<b>841.26</b>	<b>1,210.81</b>	<b>1,103.13</b>
<b>Zambia</b>	-	<b>10,240.73</b>	<b>8,973.66</b>	<b>4,918.72</b>	<b>7,079.44</b>	<b>6,449.86</b>



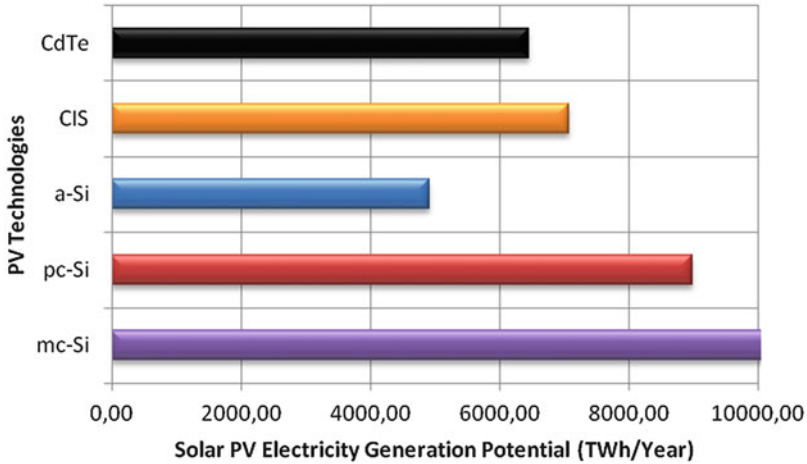
**Table 12** Provincial solar PV technical electricity generation potential by technology

Provinces	Technical Electricity Generation Potential (TWh/Year)				
	Solar PV technologies				
	mc-Si	pc-Si	a-Si	CIS	CdTe
Lusaka	266.88	233.86	128.19	184.50	168.09
Luapula	752.50	659.39	361.43	520.20	473.94
Central	1,246.70	1,092.45	598.80	861.85	785.20
Copperbelt	555.13	486.44	266.63	383.76	349.63
Northern	1,614.55	1,414.79	775.49	1,116.14	1,016.89
Northwestern	1,428.25	1,251.53	686.00	987.35	899.54
Western	1,751.49	1,534.78	841.26	1,210.81	1,103.13
Southern	2,058.15	1,803.50	988.55	1,422.80	1,296.27
Eastern	567.08	496.92	272.38	392.03	357.16
Zambia	<b>10,240.73</b>	<b>8,973.66</b>	<b>4,918.72</b>	<b>7,079.44</b>	<b>6,449.86</b>



**Fig. 20** Comparison of theoretical, geographical, and technical solar energy potential

While Zambia has abundance suitable areas (Fig. 14) and almost evenly distributed sunlight (Figs. 1 and 2) across the country, the focus on surface and suitable areas in the nine provinces and solar irradiation levels, the following can be identified. These factors however should be considered in the planning of national energy mix and also for management of electricity in the national grid once the penetration of solar PV technologies increases and becomes a significant part in the national electricity generation.



**Fig. 21** Comparison of solar PV cell technologies electricity generation potential

- The highest theoretical solar energy potential is in Northern Province (313,025.37TWh/year) due to large surface areas of the province.
- However, the highest geographical and technical solar energy potential for solar electricity generation is in Southern Province (35,117.56TWh/year) due to large available suitable areas.
- From highest yield point of view, due to abundance of sunlight received by Western province (5.89kWh/m<sup>2</sup>-day), the annual yields per installed solar PV systems peak are expected in Western province as compared to the rest of the country.
- Comparing the PV technologies, large electricity generation differences can be observed not only at district level but also at provincial levels. Table 13 indicates crystalline silicon based PV technologies have higher electricity generation potential as compared to thin film per square kilometer.

Table 13 summarizes the estimated solar PV technical electricity generation and solar PV power capacity potential in Zambia for each nine (9) provinces investigated in this chapter.

## Conclusion

This chapter provides an approach for identifying and mapping the potential sites for sustainable development of solar PV technologies based power plants using GIS spatial analysis. The chapter has integrated the geographical and technological factors as well as the Laws of Zambia on environmental protection and pollution control legislative framework for evaluating the electricity generation potential and feasible sites suitable for sustainable PV systems deployment across Zambia.

**Table 13** National solar PV technical electricity generation potential

Provinces	Annual average solar irradiation (kWh/m <sup>2</sup> -day)	Total surface area (km <sup>2</sup> )	Total suitable area (km <sup>2</sup> )	Theoretical energy potential (TWh/Year)	Geographical energy potential (TWh/year)	Technical Power Potential (GWp)						Technical electricity generation potential (TWh/Year)					
						Solar PV technologies			Solar PV technologies			Solar PV technologies			Solar PV technologies		
						mc-Si	pc-Si	a-Si	CIS	CdTe	mc-Si	pc-Si	a-Si	CIS	CdTe	mc-Si	pc-Si
Lusaka	5.70	21,896	2,152.70	45,554.63	4,476.62	153.69	134.48	71.72	107.59	97.80	266.88	233.86	128.19	184.50	168.09		
Luapula	5.78	50,567	6,066.92	106,760.30	12,808.87	433.35	379.18	202.23	303.35	275.77	752.50	659.39	361.43	520.20	473.94		
Central	5.76	94,394	10,051.37	198,511.37	21,138.12	717.96	628.21	335.05	502.57	456.88	1,246.70	1,092.45	598.80	861.85	785.20		
Copperbelt	5.75	31,328	4,475.66	65,726.77	9,390.02	319.69	279.73	149.19	223.78	203.44	555.13	486.44	266.63	383.76	349.63		
Northern	5.83	147,186	13,017.14	313,025.37	27,683.98	929.80	813.57	433.90	650.86	591.69	1,614.55	1,414.79	775.49	1,116.14	1,016.89		
Northwestern	5.74	125,826	11,515.06	263,421.22	24,107.19	822.50	719.69	383.84	575.75	523.41	1,428.25	1,251.53	686.00	987.35	899.54		
Western	5.89	126,386	14,121.15	271,908.65	30,380.45	1,008.65	882.57	470.71	706.06	641.87	1,751.49	1,534.78	841.26	1,210.81	1,103.13		
Southern	5.80	85,823	16,593.56	181,630.34	35,117.56	1,185.25	1,037.10	553.12	829.68	754.25	2,058.15	1,803.50	988.55	1,422.80	1,296.27		
Eastern	5.68	69,208	4,572.038	143,482.03	9,478.75	326.57	285.75	152.40	228.60	207.82	567.08	496.92	272.38	392.03	357.16		
<b>Zambia</b>	<b>5.77</b>	<b>752,614</b>	<b>82,564.60</b>	<b>1,590,020.67</b>	<b>174,581.55</b>	<b>5,897.46</b>	<b>5,160.28</b>	<b>2,752.16</b>	<b>4,128.24</b>	<b>3,752.93</b>	<b>10,240.73</b>	<b>8,973.66</b>	<b>4,918.72</b>	<b>7,079.44</b>	<b>6,449.86</b>		

Thus, this chapter shows that Zambia has vast available solar energy technical potential for PV electricity generation. The larger PV electricity generation potential variability at district and provincial level is highly linked with the local geographical features and terrain which affect the availability of suitable area and also local solar energy resource. Therefore, integration and generation of electricity from PV systems has greater potential to mitigate the current energy shortage and increase access to energy for all in Zambia. Furthermore, the suitable land areas in almost all districts and provinces is large enough for solar energy harvesting at utility-scale PV system capable of covering the present and future total electricity demands for Zambia. The identified potential sites have a total of available suitable area of 82,564.601 km<sup>2</sup> representing 10.97% of Zambia's total surface area equivalent to 5,897.46 GW technical power potential. This translates to 10,240.73TWh/year electricity generation potential considering annual average solar irradiation of 5.78 kWh/m<sup>2</sup>-day and monocrystalline silicon solar PV technology mounted at optimal tilt angle. This potential has capacity to reduce CO<sub>2</sub> emission and contribute to achieve energy access for all and Sustainable Development Goals (SDGs).

The identification of potential sites and solar energy potential analysis will help improve the understanding of the potential solar energy, and PV technology can contribute to achieving sustainable national energy mix and increasing energy access for all in Zambia. Furthermore, it will help the government in setting up tangible energy targets and effective integration of solar PV systems into national energy mix. Hence, it is hoped that the suitability map established and the technical potential evaluated will help guide the decision makers and also the investors for planning future electricity generation targets and investment across the country and achieve the 2030 development goals.

---

## References

- Abdolvahhab Fetanat EK (2015) A novel hybrid MCDM approach for offshore wind farm site selection: a case study of Iran. *Ocean Coast Manag* 109:17–28. <https://doi.org/10.1016/j.ocecoaman.2015.02.005>
- Addisu D, and Mekonnen PV (2015) A web-based participatory GIS (PGIS) for offshore wind farm suitability within Lake Erie, Ohio. *Renew Sust Energ Rev* 41:162–177. <https://doi.org/10.1016/j.rser.2014.08.030>, ScienceDirect
- Ahmed Aly SS (2017) Solar power potential of Tanzania: identifying CSP and PV hot spots through a GIS multicriteria decision making analysis. *Renew Energy* 113:159–175. <https://doi.org/10.1016/j.renene.2017.05.077>, ScienceDirect
- Ahmed HHA et al (2017) Energy performance, environmental impact, and cost assessment for a photovoltaic plant under Kuwait climate condition. *Sustainable Energy technologies & Assessments* 22:25–33
- Alami Merrouni A, Mezrhab A, Mezrhab A (2014) CSP sites suitability analysis in the eastern region of Morocco. *Energy Procedia* 49:2270–2279. <https://doi.org/10.1016/j.egypro.2014.03.240>
- Ali HM, Hojabri M, Hamada HM, Samsuri FB, Ahmed MN (2016) Performance evaluation of two PV technologies (c-Si and CIS) for building integrated photovoltaic based on tropical climate condition: a case study in Malaysia, energy and buildings. <http://dxdoi.org/10.1016/j.enbuild.2016.03.052>

- Aly Sanoh AS (2014) The economics of clean energy resource development and grid interconnection in Africa. *Renew Energy* 62:599–609. <https://doi.org/10.1016/j.renene.2013.09.017>, ScienceDirect
- Anthony Lopez BR (2012) U.S. renewable energy technical potentials: a GIS based analysis. NREL, U.S. Department of Energy. National Renewable Energy Laboratory (NREL, Colorado. NREL/TP-6A20-51946
- Arthur Bossavy RG (2016) Sensitivity analysis in the technical potential assessment of onshore wind and ground solar photovoltaic power resources at regional scale. *Appl Energy* 182:145–153. <https://doi.org/10.1016/j.apenergy.2016.08.075>
- Ayompe LD (2014) An assessment of the energy generation potential of photovoltaic systems in Cameroon using satellite-derived solar radiation datasets. *Sustainable Energy Technologies and Assessments* 7:257–264
- Bowa CM (2017) Solar photovoltaic energy progress in Zambia: a review. SAUPEC 2017, 25th Southern African Universities Power Engineering Conference, 30 January-01 February, 2017. Stellenbosch, South Africa: SAUPEC 2017
- Brewer JR (2014) Solar PV site suitability using GIS analytics to evaluate utility scale solar power potential in the U.S: South West Region. Department of Civil and Environmental Engineering. Brigham: Brigham Young University. Retrieved April 2017
- British Standard (1998) Photovoltaic system performance monitoring, guidelines for measurement, data exchange and analysis:BS EN 61724:1998, IEC 61724: 1998. BSI 05.1999, British Standard
- Chao-Rong Chen C-CH-J (2014) Ahybrid MCDM model for improving GIS-based solar farms site selection. (C.-S. Jwo, Ed.) *International Journal of Photoenergy*:1–9. <https://doi.org/10.1155/2014/925370>
- Charabi Y, and Gastli A (2011) PV site suitability analysis using GIS-based spatial fuzzy multi criteria evaluation. *Renew Energy* 36:2554–2561. <https://doi.org/10.1016/j.renene.2010.10.037>, ScienceDirect
- Chinairm (2013) Photovoltaic industry: abandoned projects on the plateau. Chinairm. Retrieved January 2016, from <http://www.chinairm.com/print/3042250.html>
- Damon T, and Vasilis F (2011) Environmental impacts from the installation and operation of large-scale solar power plants. *Renew Sust Energy Rev* 15:3261–3270
- Didler TG (2012) The RETScreen model for assessing potential of PV projects. RETScreen England, N (2011) Solar Parks: maximising environmental benefits. Natural England
- Fylladitakis E (2015) Environmental impacts of photovoltaic systems. Brunel University, London
- Gauri SS (2013) Zambia renewable readiness assessment. International Renewable Energy Agency (IRENA), Lusaka
- Geoffrey TK, and Tidwell VC (2013) Water use and supply concerns for utility-scale solar projects in the southwestern United States. Sandia National Laboratories, Livermore
- Gipe P (1995) *Wind energy comes of age*. Wiley, New York
- Interior Department, U (2010) Impacts of solar energy development and potential mitigation measures. I Draft solar programmatic environmental impact statement, vol 1, pp 1–302. N/A: Federal Register. Accessed in July 2017
- IRENA (2012) Renewable energy technologies: cost analysis series volume1: power sector issue4/ 5. International Renewable Energy Agency (IRENA) working Paper
- IRENA (2013) Zambia renewable readiness assessment 2013. International Renewable Energy Agency (IRENA), Lusaka
- Ivan PR (2015) Analysis of insolation potential of Knjazevac Municipality (Serbia) using multi-criteria approach. *Renewable and Sustainable Energy Review*
- Janke JR (2010) Multicriteria GIS modeling of wind and solar farms in Colorado. *Renew Energy* 35:2228–2234. <https://doi.org/10.1016/j.renene.2010.03.014>. ScienceDirect
- Joss JW, and Watson MD (2015) Regional scale wind farm and solar farm suitability assessment using GIS-assisted multi-criteria evaluation. *Landsc Urban Plan* 138:20–31. <https://doi.org/10.1016/j.landplan.2015.02.001>. ScienceDirect

- Kaoshan D et al (2015) Environmental issues associated with wind energy-a review. *Renew Energy* 75:911–921. <https://doi.org/10.1016/j.renene.2014.10.074>
- Kynakis EK (2009) Performance analysis of a grid connected photovoltaic park on the island of Crete. *Energy Convers Manag* 50(3):433–438
- Lopez AR (2012) U.S renewable energy technical potentials: a GIS-based analysis. Technical Report NREL/TP-6A20–5146, United States
- Marcos Rodrigues CM (2010) A method for the assessment of the visual impact caused by the large scale deployment of renewable energy facilities. *Environ Impact Assess Rev* 30:240–246. <https://doi.org/10.1016/j.eiar.2009.10.004>
- Martin-Chivelet N (2016) Photovoltaic potential and land use estimation methodology. *Energy* 94: 233–242. <https://doi.org/10.1016/j.energy.2015.10.108>
- Ming ZS (2015) Is the “Sun” still hot in China? The study of the present situation, problems and trends of the photovoltaic industry in China. *Renew Sust Energy Rev* 23:1224–1237
- MMEWD (2008) National energy policy. Ministry of Mines, Energy and Water Development of Zambia, (MMEWD), Lusaka
- Mwanza M, et al. (2016a) Assessment of solar energy source distribution and potential in Zambia. ISEM2016, 3rd international symposium on environment and morality, 4–5 November 2016. Alanya-Turkey: ISEM2016
- Mwanza M, et al. (2016b) The potential of solar energy for sustainable water resource development and averting national social burden in rural areas of Zambia. ISEM2016, 3rd international symposium on environment and morality, 4–6 November 2016. Alanya-Turkey: ISEM2016
- Nazli Yonca A (2010) GIS-based environmental assessment of wind energy systems for spatial planning: a case study from western Turkey. *Renewable and Sustainable Energy Review* 14:364–373. <https://doi.org/10.1016/j.rser.2009.07.023>. ScienceDirect
- Quansah DA (2016) Solar photovoltaics in sub-Saharan Africa-addressing barriers, unlocking potential. *Energy Economics Iberian Conference (Energy Procedia)* 106:97–110. Lisbon, Portugal: ELSEVIER, ScienceDirect. <https://doi.org/10.1016/j.egypro.2016.12.108>
- Robert CD (2014) Using the sun to decarbonize the power sector: the economic potential of photovoltaics and concentrating solar power. *Appl Energy* 135:704–720
- Ronald CE (2016) GIS-based multi-criteria decision analysis in natural resource management. *GIS-Based Multi-Criteria Decision Analysis*. University of Tsukuba
- Saidur R, Rahim NA, Islam MR, Solangi KH (2011) Environmental impact of wind energy. *Renew Sust Energy Rev* 15(5):2423–2430. Accessed in July 2017
- Samuel AS, and Owusu PA (2016). A review of Ghana's energy sector national energy statistics and policy framework. *Civil Environ Eng*:1–27. Retrieved January 2017
- Sanchez Lozano JM et al (2013) Geographical information system (GIS) and multi criteria decision making (MCDM) methods for the evaluation of solar farms locations: case study in south eastern Spain. *Renewable and Sustainable Energy Review* 24:544–556. <https://doi.org/10.1016/j.rser.2013.03.019>. ScienceDirect
- Sanchez-Lozano JM, and García-Cascales MS (2014). Identification and selection of potential sites for onshore wind farms development in region of Murcia, Spain. *Energy*, 73(–), 311–324. <https://doi.org/10.1016/j.energy.2014.06.024>. ScienceDirect
- SEFI/UNEP (2009) Global trends in sustainable energy investment (online). SEFI/UNEP. Retrieved from <http://sefi.unep.org/english/globaltrends2009.html>;
- Shifeng W, and Sicong W (2015) Impact of wind energy on environment; a review. *Renew Sust Energy Rev* 49:437–443. <https://doi.org/10.1016/j.rser.2015.04.137>
- Siheng W et al (2016) Selecting photovoltaic generation sites in Tibet using remote sensing and geographic analysis. *Sol Energy* 133:85–93. <https://doi.org/10.1016/j.solener.2016.03.069>. ScienceDirect
- Siyasankari S, and Babu JSC (2015) Performance evaluation and validation of 5MW<sub>p</sub> grid connected solar photovoltaic plant in South India. *Energy Convers Manag* 100(2015):429–439, ScienceDirect

- Suprava C. & Pradip K.S., (2015), Technical mapping of solar photovoltaic for the coal city of India, *Renewables: Wind, Water, and Solar* (2015) 2:11, DOI 10.1186/s40807-015-0013-1
- Suri DQ (2005) PV-GIS: a web-based solar radiation database for the calculation of PV potential in Europe. *International Journal of Sustainable Energy* 24:55–67
- The Environmental Council of Zambia (1994) Chapter 204 of the Laws of Zambia, the environmental protection and pollution control act. Ministry of Legal Affairs, Government of the Republic of Zambia, Lusaka
- Tripathi B, Yadav P, Rathod S, Kumar M (2014) Performance analysis and comparison of two silicon material based photovoltaic technologies under actual climatic conditions in Western India. *Energy Convers Manag* 80:97–102
- Tsoutsos T, et al (2005) Environmental impacts from the solar energy technologies. *Energy Policy* 33:289–296
- Tsoutsos T et al (2009) Visual impact evaluation of a wind park in a Greek Island. *Appl Energy* 86: 546–553
- Turlough G (2017) A case study identifying and mitigating the environmental and community impacts from construction of a utility-scale solar photovoltaic power plant in eastern Australia. *Sol Energy* 146:94–104
- U.S. (2016). [www.energy.gov](http://www.energy.gov). Retrieved November 2016, from Office of Energy Efficiency & Renewable Energy
- Union of Concerned Scientists (2015) Environmental impacts of renewable energy technologies. Accessed in August, 2016 from Union of Concerned Scientists: Science for a healthy planet and safer world: [www.ucsusa.org/clean-energy/renewable-energy/environmental-impacts#bf-toc-0](http://www.ucsusa.org/clean-energy/renewable-energy/environmental-impacts#bf-toc-0)
- Uyan Mevlut (2013) GIS-based solar farms site selection using analytic hierarchy process in Karapinar region, Konya/Turkey. *Energy, Renewable and Sustainable Energy Review* 28:11–17. <https://doi.org/10.1016/j.rser.2013.07.042>. ScienceDirect
- Walimwipi HS (2012) Investment incentives for renewable energy in southern Africa: case study of Zambia. International Institute for Sustainable Development (IISD), Lusaka
- Wang C, and Prinn RG (2010) Potential climate impacts and reliability of a very large-scale wind farm. *Atmospheric Chemical and Physical* 10:2053–2061
- Yan-wei SA (2013) GIS-based approach for potential analysis of solarPV generation at the regional scale: a case study of Fujian Province. *Energy Policy* 58:248–259
- Yassine CA (2011) PV site suitability analysis using GIS-based spatial fuzzy multi-criteria evaluation. *Renew Energy* 36:2554–2561
- Yassine C, and Adel G (2012) Spatio-temporal assessment of dust risk maps for solar energy system using proxy data. *Renew Energy* 44:23–31. <https://doi.org/10.1016/j.renene.2011.12.005>, ScienceDirect

**Open Access** This chapter is licensed under the terms of the Creative Commons Attribution 4.0 International License (<http://creativecommons.org/licenses/by/4.0/>), which permits use, sharing, adaptation, distribution and reproduction in any medium or format, as long as you give appropriate credit to the original author(s) and the source, provide a link to the Creative Commons license and indicate if changes were made.

The images or other third party material in this chapter are included in the chapter's Creative Commons license, unless indicated otherwise in a credit line to the material. If material is not included in the chapter's Creative Commons license and your intended use is not permitted by statutory regulation or exceeds the permitted use, you will need to obtain permission directly from the copyright holder.





# Panel Analysis of the Relationship Between Weather Variability and Sectoral Output in Kenya

# 48

Olga Nekesa Mulama and Caroline Wanjiru Kariuki

## Contents

Introduction .....	948
Theoretical and Empirical Context .....	951
Theoretical Context .....	951
Empirical Context .....	952
Interactions Between the Variables Used in This Research .....	954
Approach to Identify the Relationship Between Weather Variability and Sectoral Output .....	955
Data Collected .....	955
Model on the Relationship Between Weather Variability and Sectoral Output .....	956
Procedure .....	957
Establishing the Relationship Between Weather Variability and Sectoral Output .....	957
Unit Root Test .....	957
Long-Run Relationship Between Temperature and Sectoral Output .....	958
Effect of Weather Variability on Sectoral Output .....	958
Conclusion .....	960
References .....	961

## Abstract

Climate change and economic growth are closely connected. Climate change has the potential to reduce economic growth in developing countries due to their limited ability to respond to the negative impacts of a changing climate. A better understanding of weather variability can enhance climate change policies, which

This chapter was previously published non-open access with exclusive rights reserved by the Publisher. It has been changed retrospectively to open access under a CC BY 4.0 license and the copyright holder is “The Author(s)”. For further details, please see the license information at the end of the chapter.

O. N. Mulama · C. W. Kariuki (✉)  
Strathmore Institute of Mathematical Sciences, Nairobi, Kenya  
e-mail: [olga.mulama@strathmore.edu](mailto:olga.mulama@strathmore.edu); [cwkariuki@strathmore.edu](mailto:cwkariuki@strathmore.edu)



would help to support economic growth in these countries. As such, this research sought to examine if there is a long-run relationship between sectoral output and weather variables (temperature and rainfall) and to analyze the effect of weather variability on sectoral output using a panel of 13 sectors in Kenya.

A Pedroni cointegration test was carried out to find out if there exists a long-run relationship among the variables and thereafter, a fully modified ordinary least squares regression was conducted to establish the effect of weather variability on sectoral output. The results indicate that there is a long-run relationship between temperature and sectoral output. Moreover, temperature has a larger effect on sectoral output compared to rainfall. With the evidence gathered from this research, it can be concluded that weather variability has an economic effect on sectoral output in Kenya. Given this, the Kenyan government needs to take a keen interest in understanding the effect of weather variability on the economy and in the broader picture, take steps to mitigate climate change.

---

**Keywords**

Weather variability · Climate change · Temperature · Rainfall · Sectoral output · Economic growth · Kenya · Panel data · Cointegration · Fully modified OLS

---

**Introduction**

Weather refers to the temporary conditions of the atmosphere, which is the layer of air that surrounds the earth. There are various factors that can change the atmosphere such as temperature, air pressure, humidity, wind speed, wind direction, altitude, and topography, among others. Together, these factors determine the weather in a certain area (National Centers for Environmental Information 2018). On the other hand, climate refers to the state of the weather over a long period of time in a specific area. Predictable weather is important for social and economic planning as it results in sustainable development. However, climate change could affect health, infrastructure, transportation systems, as well as energy and food supplies. There is also a global challenge of acute water scarcity, which can be attributed to the extreme temperatures. On a global scale, there is a cry for environmental conservation since extreme weather occurrences have been found to be directly linked to the environment's state. Through their research, Mortimore et al. (2009) provide insight on the pattern that developing countries have recorded in terms of extreme weather occurrences. The authors find that there has not been much investment and development to aid in preventing the damages that come with extreme weather occurrences in these countries. Developing countries are currently faced with considerable development constraints and to top it off, their poor coping and adaptation strategies to a changing environment push them deeper into development issues. The agricultural, livestock, fisheries, tourism, energy, forestry, health, and water sectors usually take the biggest blow when extreme weather events take place due to their relation and dependent nature on weather. The labor force and industries are also affected due to extreme

weather events and this eventually ends up having an adverse effect on the peace and stability of a country.

In Kenya, the country's wildlife and other tourist attractions are vulnerable to the impact of climate change. Ferrara's (2015) research revealed that tourism in Kenya would be significantly affected by a change in wildlife migration patterns (e.g., wildebeest migration) caused by changing weather. Consequently, this would have a negative effect on the country's economy given that tourism is one of the major contributors to Kenya's Gross Domestic Product (GDP). Mount Kenya, which is another major tourist attraction, has snowcaps that are melting due to increased global temperatures. Additionally, the Kenyan economy is highly dependent on agriculture which contributes approximately 33% to the nation's GDP. The agricultural sector in Kenya employs about 40% of the total population with more than 70% coming from rural areas (Food and Agriculture Organization 2019). The Food and Agriculture Organization (2019) also reports that farmers who are used to rain-fed farming systems are being pushed to areas that are vulnerable to drought due to increased human population. Furthermore, the unpredictability of weather patterns resulting from climate change does not favor their farming practices. In many developing countries, households face difficulty in adapting to climate change and very few households make a step and change their farming practices in response to climate change. Okoba et al. (2013) argue that despite the possibility to change this, many households are unable to make the costly investment and join the bandwagon in the agricultural shift. Despite developing countries having information on extreme weather occurrences, the impact of the occurrence of an extreme weather event is still very high. News of extreme weather patterns across Africa is increasingly becoming frequent and policymakers can no longer overlook this effect, which is a result of climate change. As temperatures continue to rise as a result of global warming, there are bound to be water shortages in Africa causing droughts and in the short term, occurrences of flash floods as well. The cycle effect is that agricultural output will be affected thus causing a drop in rural incomes for farmers who depend on agriculture and resulting in a decline in consumption and investment.

Evidently, climate and agriculture are highly correlated as discussed by Linke et al. (2015) who carried out a research on the relationship between climate and social instability in Kenya. Agriculture is highly dependent on favorable weather conditions. Low output from farming during unfavorable weather conditions would result in low returns on the farmers' investment and in the next agricultural season, farmers may not have enough capital to invest for their next harvest. This is a vicious cycle whereby output that is affected by the weather would affect levels of income and this in turn affects the input necessary to produce more and the cycle continues. Dell et al. (2012) seek to bring out the evidence that in fact weather and economic variables do have a direct relationship. Their research examined the relationship between temperature shocks and economic growth in both rich and poor countries. Their findings show that higher temperatures reduce agricultural output, industrial output, and political stability. Not only do changes in the weather affect the agricultural and industrial sectors of a country, but the health of the population as well. The general health of a population is usually at risk in cases of extreme weather occurrences like

drought and floods. In Kenya, infectious disease outbreaks such as waterborne, rodent-borne, and vector-borne diseases have been associated with flooding especially in areas with poor drainage systems (Okaka and Odhiambo 2018). Moreover, being on the equator, the temperate climate provides a perfect breeding ground for mosquitoes that spread malaria. Yanda and Mubaya (2011) report a rise in mosquito population in the occurrence of erratic weather where the spread of malaria and other waterborne diseases causes Kenya's income to shrink in affected areas. This is because the current labor force must attend to their sick family members and current and/or future labor force could also decrease should they succumb to diseases. Furthermore, the World Health Organization (2018) reports that diseases transmitted by insects are emerging and reemerging and epidemics are reported more frequently than before in Africa. Evidence points to climate change being a major contributor to this public health crisis. With the weak adaptive mechanisms in developing nations, adverse weather patterns are bound to have a huge impact on the entire economy affecting the majority of the population. Thus, there is a need for policymakers to plan accordingly and most especially conserve the environment and thus the economy for future generations. The erratic nature of weather patterns without adequate adaptation mechanisms has cost Kenya much more than it would have cost the country to put in place preventative measures that would reduce the scale of damage. For example, During the El Niño that occurred in 1997, Kenya made losses of up to USD one billion (Ngecū and Mathu 1999). The lack of preparation in the country adversely affected physical infrastructure due to the heavy downpour and further affected road, air, and rail transport networks.

Given this, Nyangena (2016) studied the impact of weather variability (rainfall and temperature) on economic growth in Kenya. Nyangena (2016) cited the need for further empirical explorations and as such, this research analyzed the effect of weather (temperature and rainfall) variability on sectoral output in Kenya using panel data. Specifically, this research sought to establish if there is a long-run relationship between temperature, rainfall, and sectoral output in Kenya and to determine the effect of temperature and rainfall on sectoral output in Kenya. The sectors captured in this research were agriculture and forestry; mining and quarrying; manufacturing; electricity and water; construction; wholesale and retail trade; hotels and restaurants; transport and communication; financial intermediation; real estate, renting, and business services; public administration; education; and other services.

It is important to remember the past so as to model better decisions for the future. Consequently, this chapter will make a contribution to literature by providing a deeper understanding of the effect of weather variability on economic output in Kenya using historical data. This will ultimately aid policymakers in planning and making decisions that will have a positive effect on the welfare of future generations. More specifically, the findings from this research will provide further insights on the effect of weather (temperature and rainfall) variability on sectors that contribute to Kenya's economic growth. Further, the results will assist environmentalists in campaigning for environmental conservation and promote the use of environmentally friendly products, methods, and clean energy. Institutions such as The National Environment Management Authority of Kenya and the Green Belt Movement

together with the Ministry of Environment and Natural Resources and are not only involved in environmental campaigns but also advocate for policies and strategies that will help conserve the environment and mitigate the effects of climate change. The Ministry of Agriculture also stands to make more informed decisions that will benefit farmers and offer insight on policies regarding food security in Kenya related to weather variability.

---

## Theoretical and Empirical Context

### Theoretical Context

#### Chaos Theory

Making future weather forecasts is hard. It is only predictable to forecast the weather behavior in the future when a trend is observed from some initial weather conditions. Stephens et al. (2012) state that it is easier to predict climate than weather because weather is governed by an imbalance of the world's energy forces. A chaotic system is purely deterministic assuming absolute dynamism to the extent of exhibiting unpredictability in standard statistical tests, rendering it chaotic. Chaos theory, as described by Lorenz (1963) is the confusion, disorder, unpredictability, turbulence, and uncertainty in a spectrum of things. A chaotic system is one that is affected by initial occurrences and dynamic nonlinear patterns that are not fundamentally random. Understanding the initial points is fundamental for predictability to hold. Weather patterns are nearly impossible to predict due to their chaotic nature. However, with the advent of computers and their ability to handle massive amounts of data, there is a better possibility of predicting the weather. An essential observation would be to see how many times the weather predictions have merged with the actual weather occurrences. As observed from past weather occurrences, there is generally a disparity most times and this is attributed to the possibility of climate change taking place. A general standard stochastic test can be useful in distinguishing a set of randomness and chaos.

#### Climate Change Theories

Hulme (2009) describes climate science as a function of the limits of science itself. Mathematicians working on climate systems find that uncertainties in climate prediction arise not only from initial conditions and forcing scenarios but also from model formulation. Further, the anthropogenic global warming theory admits that the climate system is naturally chaotic. Most people are familiar with anthropogenic global warming, which is manmade global warming. Under the theory of anthropogenic global warming, it holds that manmade greenhouse gases are the main cause of global warming that has occurred during the past 50 years. As the years have progressed, loopholes have been found in this theory and new evidence shows that other natural factors contribute to modern global warming. The theory of anthropogenic global warming is contested by other theories, some of which include the theory of the Bio-thermostat, which claims negative feedback from biological and

chemical processes offset whatever positive feedback might be caused by the rising carbon dioxide levels (Idso and Singer 2009). Sud et al. (1999) observed cloud coverage and formation. They found that the cloud coverage acted as a thermostat to regulate sea surface temperatures to a temperature of 28 °C and 30 °C. In a separate theory on human forcing, Matsui and Pielke (2006) explain that human activities such as deforestation, aerosols and ozone, coastal development, and jet contrails (the trail left behind by jets) transform the earth's surface. Additionally, carbon dioxide emissions as a result of human activities play a dominant role on long-term climate change. The US Global Change Research Program (2014) reports changes in the earth's climate due to the earth warming, with a key indicator of climate change being extreme weather and climate events.

### **Economic Growth**

The neoclassical theory on economic growth states that the stock of capital, supply of labor, and technological developments are factors that affect the growth of an economy. The theory further explains the law of diminishing returns where increasing capital and labor have a limited impact on increasing economic growth. The new economic growth theories criticized the neoclassical theories stating that labor productivity does not have diminishing returns but rather has increasing returns and emphasis is put on the type of capital investment. Smith (1776) emphasized the dependency of economic growth on labor efficiency through division of labor. Additionally, Montesquieu and De Secondat (1748) argued that excess heat made men slothful and dispirited. As such, adverse climatic conditions affect laborers' well-being and this in turn affects their output ultimately affecting economic growth. Moreover, the Malthus theory predicts that economic growth may have limitations caused by changes in the climate, overpopulation, and scarcity of resources.

In his earlier studies, Barro (1999) explains that the growth rate of real per capita GDP was associated with higher levels of schooling. This is because an additional year in school enhances workforce capability to work and increases productivity. Real GDP per capita as used in this context is the measure of the economy's total output in a country divided by the population and further adjusted for inflation. Workers level of education is a measure of human capital and is directly related to productivity. Under the Harrod–Domar theory, capital formation is given more weight on its effect on economic growth. The Harrod–Domar theory emphasizes the importance of national savings and productivity of capital investment as central to economic growth. The growth of an economy is dependent on demand created from newly generated income such that output produced by new investments can be fully absorbed. Ultimately, this should increase the production capacity of the economy. This theory further assumes that labor and capital are complementary to each other.

### **Empirical Context**

A report by the Intergovernmental Panel on Climate Change (2014) warned that global temperatures are expected to increase by an estimate of 4 °C by 2100 (World Bank

2012). Considering these projections, economists and policymakers are faced with the need to quantify the impact of weather patterns, specifically rising temperatures on economic activity. Nordhaus (2010) cites the significant effects of extreme weather events on the level of the US GDP. According to Dell et al. (2012), in their analysis of the relationship between temperatures and aggregate economic activity, hot countries tend to be poor, with national income falling 8.5% per degree Celsius in the world cross-section. With the recent interest in climate change, it is a matter of concern to understand the impact of the weather on all aspects of life. Colacito et al. (2019) estimated the effect of temperature on the growth rate of US GDP using a panel of the US states. From their estimates, they concluded that if the current trend in rising temperatures does not change, then a drop of economic growth by up to one third could occur. Further, in their estimation, they found that summer and fall exhibited opposite signs. Summer and fall had opposite effects on the US Gross State Product (GSP). This meant that rising temperatures during summer decreased economic growth as estimated by GSP and a significant rise during fall as the temperatures decreased. There has been a difficulty in concluding the general effect of weather patterns using annual data as each year presents different seasons. This heterogeneous effect can be dealt with by using more frequent data to represent the weather patterns.

In their inquiry, Linke et al. (2015) speculated that the future will get warmer, wetter, and wilder climates will be experienced. Ultimately, there is and still will be a surge of migrants and new wars. Intercommunity battles for resources increase conflicts and violence driven by calculation and political gain. According to the Food and Agriculture Organization of the United Nations (2019), increased competition for natural resources in Kenya has sparked escalated conflicts in some of the areas. Abidoye and Odusola (2015) examined the link between economic growth and climate change and found that the vulnerability of most African economies to climate change is of concern. A fair majority of the working population largely depend on informal employment in economic sectors that are sensitive to climate change (such as agriculture, forestry, energy, tourism, coastal, and water resources). Temperature was seen to have a negative impact on GDP growth where a 1 °C change in temperature would result in an inverse change in GDP growth by 0.67%. Given this, there is a need to manage the impact of climate change on Africa's economy to ensure developmental growth. In another article, Deryugina and Hsiang (2014) explored within-country variation in the United States and found that daily temperature above certain thresholds (15 °C and 30 °C) reduces the productivity level. In a related paper, Zivin and Neidell (2014) find that warmer temperatures reduce labor supply in the United States, thus providing an economic rationale for why climate change might affect economic activity in a developed economy. There has been a correlation between poverty and heat as suggested by Montesquieu and De Secondat (1748), who argue that excess heat made men slothful and dispirited.

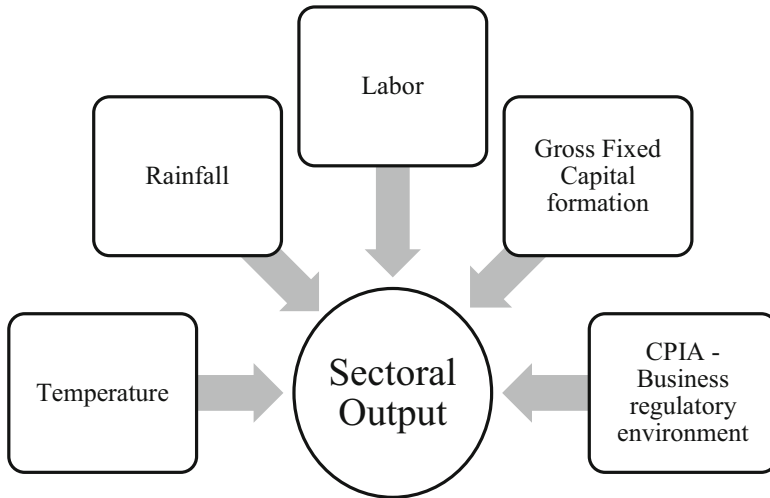
Several other studies have focused on agriculture specifically and there is an evident inverse relationship between agricultural productivity and extreme weather occurrences although this is dependent on the crop type. Beyond agricultural constraints as a result of climate change, Awuor et al. (2008) found that floods lead to serious loss of life and property, which coastal towns such as Mombasa face

as a result of climate change. Mombasa is a major contributor to Kenya's GDP through tourism, industries, imports, and exports and serves both Kenya and landlocked countries around it. Floods lead to loss of life, displacement of people, and destruction of infrastructure. Floods can occur at any time despite weather or climate patterns influencing when and where these floods occur (Smith 2002). Although drought affects more people than floods do, disease outbreaks such as malaria, typhoid, bilharzia, and dysentery have been seen to cripple labor productivity. Flood disasters are associated with the presence of flood hazards due to the nature of the terrain or flood vulnerability, which is attributed to poor regulation, poor land use, degradation of water catchment areas, poverty, population pressures, and settlement patterns (Opere 2013).

In a more recent research done in Kenya, Nyangena (2016) explored the relationship between GDP per capita, annual temperature changes, and annual rainfall and found that a unit change in temperature resulted in approximately 142 times change in GDP per capita arguing that temperature has a greater effect on GDP than rainfall. The empirical literature in Kenya revealed some inconsistencies with other bodies of literature that have sought out to explore the role of weather and climate changes in economic growth (Nyangena 2016). The findings of earlier studies revealed that temperature variability had an inverse relationship with economic growth (e.g., Colacito et al. 2019; Dell et al. 2012) whereas Nyangena (2016) found a positive relationship between temperature and economic growth. Nyangena (2016) determined the long-run relationship between economic growth and weather and used a vector error correction model to analyze the impact of weather variability on economic growth. On the other hand, this research aims to analyze the effect of weather variability on 13 different sectors in the Kenyan economy as opposed to the economy at an aggregate level. The sectors included in this research are: agriculture and forestry; mining and quarrying; manufacturing; electricity and water; construction; wholesale and retail trade; hotels and restaurants; transport and communication; financial intermediation; real estate, renting, and business services; public administration; education; and other services. Additionally, this chapter will also provide insight as to whether there is a long-run relationship between weather variability and output from the 13 sectors that contribute to Kenya's overall economic growth.

## **Interactions Between the Variables Used in This Research**

The dependent variable in this research was sectoral output (measured using GDP per sector) focusing on the following sectors: agriculture and forestry; mining and quarrying; manufacturing; electricity and water; construction; wholesale and retail trade; hotels and restaurants; transport and communication; financial intermediation; real estate, renting and business services; public administration; education; and other services. The sectors were chosen based on availability of historical information. GDP per sector is the contribution that the sector has on overall GDP. The independent variables were temperature, rainfall, gross fixed capital formation, labor, and the business regulatory environment captured using the country policy and institutional assessment (CPIA) (Fig. 1).



**Fig. 1** Interactions between the variables used in this research

The Cobb–Douglas function drives the concept behind the variables chosen. Labor and capital should have a positive relationship with output, and in this case, the sectoral output is expected to have a positive relationship with gross capital formation because increased investments are expected to increase production and as such there would be more output, which is plowed back to investments and the cycle continues. The CPIA rating is expected to have a positive relationship with sectoral output where policy improvements would positively impact output growth. Labor is also expected to have a positive relationship with sectoral output because the labor force is key to increasing productivity up to a certain level. An increase in productivity due to labor just like capital formation should result in an increase in output, which would be eventually plowed back as investments, which could take the form of increased labor opportunities. The weather variables (rainfall and temperature) on the other hand are expected to have an inverse relationship with sectoral output should there be a significant increase or decrease. For example, in the case of agriculture, a significant increase or decrease in temperature and/or rainfall will affect agricultural yield, reducing production and in the long-run causing a decline in output, which is GDP per sector in this case.

## **Approach to Identify the Relationship Between Weather Variability and Sectoral Output**

### **Data Collected**

This research sought to determine the effect of temperature and rainfall on sectoral output in Kenya and further establish if there is a long-run relationship between temperature, rainfall, and sectoral output in Kenya. This research studied the sample



overtime using past information, which made it possible to establish the direction and magnitude of the effect of the independent variables on the dependent variable.

According to the data availability on Kenya National Bureau of Statistics, the Kenyan economy has 13 economic sectors. The major industries include agriculture, forestry, fishing, mining, manufacturing, energy, tourism, and financial services. For this chapter, data on all 13 economic sectors over a period of 10 years, from 2008 to 2017 was used to establish the effect of weather variability on the economy. To capture the effects of weather variability of economic sectors in Kenya, the start year of the research was 2008 but due to the unavailability of the most recent data on weather in Kenya, this research was limited to the years 2008–2017. Weather is generally described using the following atmospheric conditions: Temperature, wind, precipitation, and sunlight. Being in the tropics (at the equator) precipitation is generally experienced as rainfall and as such, due to limited data, the variables used to measure weather variability in this chapter are rainfall and temperature over a period of 10 years from 2008 to 2017.

The data used was collected from secondary sources and comprised observations of variables over time with a cross-sectional dimension based on economic sectors. As such, panel data was used for this research. Variables used were temperature in degrees Celsius, rainfall in millimeters, GDP per sector in local currency, gross fixed capital formation in local currency, labor, and CPIA. The data for temperature in degrees Celsius, rainfall in millimeters were obtained from the World Bank Climate Change portal. Data for GDP per sector in local currency were obtained from the Kenya National Bureau of Statistics. Gross fixed capital formation data in local currency, which was measured as the annual net increase in physical assets was obtained from the World Bank Development Indicators. The data for labor, which measures the number of people employed was also obtained from the World Bank Development Indicators, while the CPIA data, which measures the implication of the legal, regulatory, and policy environments that help or hinder private businesses in investing, creating jobs, and becoming more productive was obtained from the World Bank Country Policy and Institutional Assessment database. All variables used for this research had an annual frequency.

## **Model on the Relationship Between Weather Variability and Sectoral Output**

A panel data model was estimated and used to analyze the data. This model was used to provide information on the effect of temperature and rainfall on sectoral output in Kenya and was estimated using the fully modified ordinary least squares (FMOLS) method. All the variables were transformed into natural logarithms thus allowing the coefficient estimates to be interpreted as elasticities. The dependent variable of the model was GDP per sector (sectoral output) defined as the share that each sector contributes toward GDP. The independent variables were temperature measured in degrees Celsius and rainfall in millimeters. Additionally, following the Cobb-Douglas function of measuring productivity, the gross fixed capital formation was

included to account for capital and labor force was used to account for human capital. The business regulatory environment was also captured using the country policy and institutional assessment (CPIA). Below is the econometric model:

$$\ln GDP \text{ per sector}_{it} = \beta_0 + \beta_1 \ln Capital \text{ formation}_{it} + \beta_2 \ln Labor_{it} + \beta_3 \ln Temp_{it} + \beta_4 \ln Rain_{it} + \beta_5 \ln CPIA_{it} + \omega_{it}$$

Where:  $\beta_0$  is the intercept, which is the same for all the sectors and over time.  $\beta_1$  to  $\beta_5$  are slope parameters. The subscript  $i$  refers to an individual sector and  $t$  refers to the years from 2008 to 2017.  $\omega_{it} = \varepsilon_i + u_{it}$ .  $\varepsilon_i$  measures the random deviation of each sector's intercept from the common intercept term  $\beta_0$  and  $u_{it}$  is the residual term for sector  $i$  at time  $t$ . *Capital formation* is the net increase in physical assets, *Labor* captures the number of people employed, *Temp* captures temperature in degrees Celsius, *Rain* captures rainfall in millimeters, and *CPIA* captures the business regulatory environment as a rating (1 = low to 6 = high).

## Procedure

Before investigating the existence of a long-run relationship between weather variability and sectoral output, a unit root test was carried out. Unit root tests are used to find out if a series of variables is stationary or nonstationary. When a series is stationary, the variables are time-invariant and are better suited for making forecasts. This research employed the Im, Peseran, and Shin (IPS) unit root test. Next, a test for the existence of a long-run relationship between weather variability and sectoral output using a cointegration test was carried out. A panel cointegration approach was employed and the principal idea was to investigate the existence of a long-run relationship among the nonstationary variables. Finally, a fully modified ordinary least squares (FMOLS) procedure was adopted to estimate the effect of weather variability on sectoral output. Pedroni (1996) brings forth the FMOLS as a solution to tackling non-exogeneity and serial correlation problems. Additionally, FMOLS addresses the problem of nonstationary variables as well as simultaneity biases.

---

## Establishing the Relationship Between Weather Variability and Sectoral Output

### Unit Root Test

In order to establish whether the distribution of the variables used in this research does not change with time (stationarity), unit root tests were carried out. The results in Table 1 are a result of conducting an Im, Peseran, and Shin (IPS) panel unit root test at level, first difference, and second difference. When conducting a unit root test, the null hypothesis is the presence of a unit root and rejecting the null means that the variable is stationary. The null hypothesis is rejected when the p-value is smaller than

**Table 1** Unit root test results

Variable	Level	First-order difference	Second-order difference
GDP per sector	-0.4362 (1.000)	-2.8004 <sup>a</sup> (0.0001)	
Temperature	0.2327 (1.000)	-2.4535 (0.2990)	-2.3519 <sup>a</sup> (0.0022)
Rainfall	-3.8568 <sup>a</sup> (0.0000)		
Capital formation	-1.5808 (0.1887)	-3.2164 <sup>a</sup> (0.0000)	
Labor	-0.8516 (0.9791)	-0.5463 (0.9995)	-3.0059 <sup>a</sup> (0.0000)
CPIA	-2.3886 <sup>a</sup> (0.0010)		

P-values in parenthesis

<sup>a</sup>Statistically significant at the 5% level of significance

**Table 2** Panel cointegration results

Test	Level
Modified Phillips-Perron test	3.0714 <sup>a</sup> (0.0011)
Phillips-Perron	1.9829 <sup>a</sup> (0.0237)

P-values in parenthesis

<sup>a</sup>Statistically significant at the 5% level of significance

0.05 ( $p < 0.05$ ). At level, the null hypothesis is rejected for rainfall and CPIA indicating stationarity. At first difference, the null hypothesis is rejected for GDP per sector and capital formation and finally, at second difference, the null hypothesis is rejected for temperature and labor.

## Long-Run Relationship Between Temperature and Sectoral Output

Next, cointegration was tested. This test was used to find out if there exists a long-run relationship between sectoral output and temperature. Rainfall is not taken into account in this test as it is a stationary variable at level. The p-values in Table 2 are the values in parenthesis and are highlighted by an asterisk at a 95% confidence level. Given that the p-values of the cointegration tests are less than 0.05 ( $p < 0.05$ ), the null hypothesis of no cointegration is rejected. This result indicates that there is a long-run relationship between sectoral output and temperature, which answers the research objective of establishing if there is a long-run relationship between weather variability and sectoral output in Kenya. The long-run relationship between the temperature and sectoral output supports the findings of Nyangena (2016) who found that weather and output in Kenya had a long-run relationship.

## Effect of Weather Variability on Sectoral Output

After establishing the presence of a long-run relationship between sectoral output and temperature, a method known as fully modified ordinary least squares (OLS)

**Table 3** Fully modified ordinary least squares results

Variable	Coefficient	P-value	Standard error
Temperature	-4.0229	0.7086	10.7312
Rainfall	0.1920	0.6976	0.4927
CPIA	0.7531	0.7624	2.4837
Capital formation	-0.8404	0.4746	1.1710
Labor	8.2220 <sup>a</sup>	0.0102	3.1398

<sup>a</sup>Statistically significant at the 5% level of significance

was used to establish the relationship between weather variability and sectoral output. The results of the estimation are shown in Table 3.

The results in Table 3 show that there is a negative effect of temperature in degree Celsius on sectoral output, where a 1% increase in temperature leads to a 4.02% decrease in sectoral output holding all other factors constant. Regarding rainfall in millimeters, there is a positive relationship with sectoral output where a 1% increase in rainfall would result in a 0.19% increase in sectoral output holding all other factors constant. Colacito et al. (2019) also found an increase in temperature resulted in possible declines in economic growth. As seen in this chapter, there also exists an inverse relationship between temperature and sectoral output. Moreover, the inverse relationship between temperature and sectoral output is of a higher magnitude in comparison to the relationship between rainfall and sectoral output. This is consistent with the findings of Ochieng et al. (2016) who reported that temperature has a bigger effect on crop production in Kenya than rainfall. This chapter also supports the findings of Van-Passel et al. (2012) who argued that agricultural output is positively affected by rainfall when received on season and is good for overall economic performance. Even though this chapter found that rainfall has a positive effect on sectoral output, one should also keep in mind that continued heavy rain is likely to cause economic losses in Kenya as revealed by Ngecū and Mathu (1999) in their research. This research cannot particularly rule out this effect as it does not consider the seasonality of weather and the shocks therein.

The business regulatory environment as measured by the Country Policy and Institutional Assessment (CPIA) has a positive relationship with sectoral output where a 1% increase in the CPIA rating would result in an increase of sectoral output by 0.75% holding all other factors constant. The findings of this chapter also support the research carried out by Kimenyi et al. (2016) who reported that policy improvement would result in economic transformations and sustained economic growth in the sectors in Kenya.

Additionally, labor, which is the number of people employed, also has a positive relationship with sectoral output. A 1% increase in labor would result in an 8.22% increase in sectoral output holding all other factors constant. These results support the findings of Kimenyi et al. (2016) who found a positive correlation between human capital and productivity growth in Kenya. Further, they discuss the role of investment in education to improve the quality of human capital and spur rapid economic growth in the country.

Finally, capital formation and sectoral output have a negative relationship where a 1% increase in capital formation results in a 0.84% decrease in sectoral output holding all other factors constant. These results are different from the analysis carried out by Ongo et al. (2014) who find that technical progress and infrastructural development have a positive association with economic growth in the Economic and Monetary Community of Central Africa. Interestingly, the findings from Zeb (2013) indicate that the quality of capital falls as temperature increases and results in a drop in economic growth. With the exception of labor, all other variables in the model are not statistically significant. This indicates that weather variability in Kenya does not have a significant direct impact on sectoral output in the country. However, the annual nature of the data used in this research meant that the seasonal effects of weather variability on sectoral output were not captured, which may have led to the weather variables being statistically insignificant. Due to the unavailability of quarterly data (labor, gross fixed capital formation, and CPIA – business regulatory environment), this chapter was unable to take into account the seasonal effects of these variables.

---

## Conclusion

The results from this chapter indicate the presence of a long-run relationship between sectoral output in Kenya and temperature. Furthermore, there is an inverse relationship between temperature and sectoral output, which shows that an increase in temperature will lead to a decrease in sectoral output in Kenya. On the other hand, this research finds a positive relationship between rainfall and sectoral output, which reveals that an increase in rainfall in the country is likely to lead to an increase in GDP per sector. Kenya's economy is highly reliant on the agricultural sector with most small-scale farmers relying on rain-fed farming. As such, an increase in consistent rainfall will lead to increased agricultural output as long as the rainfall is not in excess. Additionally, findings from this chapter show that the business regulatory environment as measured by the World Bank CPIA rating has a positive relationship with sectoral output. This implies that a better policy and institutional framework will lead to higher output in the various sectors in Kenya. The number of people employed also has a positive relationship with sectoral output. Gross fixed capital formation, which measures the annual net increase in physical assets has a negative relationship with GDP per sector in Kenya.

With the evidence gathered from this research, it can be concluded that weather variability has an economic effect on output from the different sectors in Kenya. This suggests that the Kenyan government needs to take a keen interest in understanding and addressing the effects of weather variability and in a broader picture, the effect of climate change on each sector of economy. Some of the sectors may bear more of the brunt due to their dependent nature on weather. However, none of the sectors in the Kenyan economy will be left unaffected due to the effects of changing weather patterns and in the long term, climate change. Therefore, the Kenyan government should ensure that it fully supports the National Adaptation Plan, which is supported

by the Climate Change Act that was enacted into law in May 2016. Additional support and increased partnerships will also be required for Kenya to achieve its climate adaptation goals. For example, Kenya needs to actively take a broader perspective that encompasses other countries including those outside the African continent in its environmental conservation discussions. This is because the impact of climate change affect all countries across the globe. As much as temperature and rainfall levels in Kenya are not at extreme levels, there has been a notable change in the weather patterns and the effects are starting to be felt. Given this, Kenya should consider being more aggressive in its reforestation campaign throughout the country. This will help to remove excess carbon dioxide emissions from the atmosphere, thus reducing the severity of weather pattern changes and in the long-run, mitigate climate change. Further research could be carried out to investigate the effect of weather variability on the Kenyan economy using data with a higher frequency. This would help to factor in the effect of climatic seasons in the country on the economy.

---

## References

- Abidoye B, Odusola A (2015) Climate change and economic growth in Africa: an econometric analysis. *J Afr Econ* 25:1–25. <https://doi.org/10.1093/jae/eju033>
- Awuor C, Orindi V, Adwera O (2008) Climate change and coastal cities: the case of Mombasa, Kenya. *Environ Urban* 20:231–242
- Baro R (1999) Determinants of economic growth: implication of the global evidence for Chile. *Cuad Econ* 36(107):443–478
- Colacito R, Hoffmann B, Phan T (2019) Temperature and growth: a panel analysis of the United States. *JMCB* 51:313–368. <https://doi.org/10.1111/jmcb.12574>
- Dell M, Jones B, Olken B (2012) Temperature shocks and economic growth: evidence from the last half century. *Am Econ J Macroecon* 4:66–95
- Deryugina T, Hsiang S (2014) Does the environment still matter? Daily temperature and income in the United States. NBER Working Paper (No. w20750; w20750)
- Ferrara E (2015) *The atlas of climate change: mapping the World's greatest challenge*. University of California Press, Berkeley
- Food and Agriculture Organization of the United Nations (2019) Kenya at a glance: the agriculture sector in Kenya. Retrieved from <http://www.fao.org/kenya/fao-in-kenya/kenya-at-a-glance/en/>
- Hulme M (2009) *Why we disagree about climate change*. Cambridge University Press, Cambridge, UK
- Idso C, Singer S (2009) *Climate change reconsidered*. The Heartland Institute, Chicago
- Intergovernmental Panel on Climate Change (2014) Summary for policymakers. Contribution of working group II to the fifth assessment report of the intergovernmental panel on climate change. Cambridge University Press, New York
- Kimenyi M, Mweha F, Ndung'u N (2016) Kenya economic growth, labor market dynamics, and prospects for a demographic dividend. In: Borat H, Tarp F (eds) *Africa's lions: growth traps and opportunities for six African economies*. Brookings Institution Press, Washington, DC, pp 4, 109–4, 144
- Linke M, O'Loughlin J, McCabe T, Tir J, Witmer F (2015) Rainfall variability and violence in rural Kenya: investigating the effects of drought and the role of local institutions with survey data. *Glob Environ Chang* 34:35–47
- Lorenz EN (1963) Deterministic nonperiodic flow. *J Atmos Sci* 20:130–141
- Matsui T, Pielke RA (2006) Measurement based estimation of the spatial gradient of aerosol radiative forcing. *Geospatial Res Lett* 33:L11813

- Montesquieu B, De Secondat C (1748) *The spirit of laws*. Batoche books: Kitchener, London
- Mortimore M, Anderson S, Cotula L, Davies J, Faccar K, Hesse C, Wolfangel C (2009) *Dryland opportunities: a new paradigm for people, ecosystems and development*. International Union for Conservation of Nature and Natural Resources (IUCN), Gland
- National Centers for Environmental Information (NCEI) (2018) <http://www.ncei.noaa.gov/news/weather-vs-climate>. Accessed 14 Mar 2020
- Ngecũ WM, Mathu EM (1999) The El-Nino-triggered landslides and their socioeconomic impact on Kenya. *Environ Geol* 38(4):277–284
- Nordhaus WD (2010) The economics of hurricanes and implications of global warming. *Clim Change Econ* 1:1–20
- Nyangena OM (2016) *The impact of weather variability on economic growth in Kenya*. University of Nairobi Press. [https://papers.ssrn.com/sol3/papers.cfm?abstract\\_id=3161257](https://papers.ssrn.com/sol3/papers.cfm?abstract_id=3161257)
- Ochieng J, Kirimi L, Mathenge M (2016) Effects of climate variability and change on agricultural production: the case of small scale farmers in Kenya. *NJAS - Wageningen J Life Sci* 77:71–78
- Okaka FO, Odhiambo BDO (2018) Relationship between flooding and out break of infectious diseases in Kenya: a review of the literature. *J Environ Public Health*. <https://doi.org/10.1155/2018/5452938>
- Okoba B, Bryan E, Ringler C, Roncoli C, Silvestri S, Herrero MT (2013) Adapting agriculture to climate change in Kenya: household strategies and determinants. *J Environ Manag* 114:26–35
- Ongo NB, Vukenkeng AW, Seppo MP (2014) Mechanisms of the influence of human capital on economic growth: a panel data analysis of CEMAC region. *Asian Econ Financ Rev* 4(5):625–640
- Opere A (2013) *Floods in Kenya*. In: Paron P, Olago DO, Omuto CT (eds) *Developments in earth surface processes*. Elsevier, Oxford
- Pedroni P (1996) Fully modified OLS for heterogeneous cointegrated panels and the case of purchasing power parity. Working paper in Economics 96(020). <https://web.williams.edu/Economics/pedroni/WP-96-20.pdf>
- Smith A (1776) *An inquiry into the nature and causes of the wealth of nations*. (Cannan ed.) <https://oll.libertyfund.org/titles/smith-an-inquiry-into-the-nature-and-causes-of-the-wealth-of-nations-cannan-ed-vol-1>
- Smith L (2002) What might we learn from climate forecasts? USA: *Proc Natl Acad Sci* 99(Suppl 1):2487–2492
- Stephens G, Li JL, Wild M, Clayson C, Loeb N, Kato S, Andrews T (2012) An update on Earth's energy balance in light of the latest global observations. *Nat Geosci* 5(10):691–696
- Sud Y, Walker G, Lau W (1999) Mechanisms regulating sea-surface temperatures and deep convection in the tropics. *Geophys Res Lett* 26(8):1019–1022
- U.S. Global Change Research Program (2014) *Global change*. Retrieved from Extreme weather: <https://nca2014.globalchange.gov/highlights/report-findings/extreme-weather>
- Van Passel S, Massetti E, Mendelson RO (2012) A ricardian analysis of the impact of climate change on european agriculture. *Nota Di Lavoro*, 83
- World Bank (2012) *Turn down the heat: why a 4C warmer world must be avoided*. Potsdam Institute for Climate Impact Research and Climate Analytics. <https://openknowledge.worldbank.org/handle/10986/11860>
- World Health Organization (2018, November 7) *Climate change increases risk of outbreaks in Africa*. Retrieved from WHO Africa: <https://www.afro.who.int/news/climate-change-increases-risk-outbreaks-africa>
- Yanda PZ, Mubaya CP (2011) *Managing a changing climate in Africa: local level vulnerabilities and adaptation experiences*. African Books Collective. <http://www.africanbookscollective.com/books/managing-a-changing-climate-in-africa>
- Zeb A (2013) Climate change and economic growth in Nordic countries: an application of smooth coefficient semi-parametric approach. *Int J Soc Sci* 11(3):159–171
- Zivin J, Neidell M (2014) Temperature and the allocation of time: implications for climate change. *J Labor Econ* 32(1):1–26

**Open Access** This chapter is licensed under the terms of the Creative Commons Attribution 4.0 International License (<http://creativecommons.org/licenses/by/4.0/>), which permits use, sharing, adaptation, distribution and reproduction in any medium or format, as long as you give appropriate credit to the original author(s) and the source, provide a link to the Creative Commons license and indicate if changes were made.

The images or other third party material in this chapter are included in the chapter's Creative Commons license, unless indicated otherwise in a credit line to the material. If material is not included in the chapter's Creative Commons license and your intended use is not permitted by statutory regulation or exceeds the permitted use, you will need to obtain permission directly from the copyright holder.







# Agro-ecological Lower Midland Zones IV and V in Kenya Using GIS and Remote Sensing for Climate-Smart Crop Management

49

Hilda Manzi and Joseph P. Gweyi-Onyango

## Contents

Introduction .....	966
Climate Change and Its Impacts in Lower Midland Agro-ecological Zones IV and V .....	966
Climate Variability in Agro-ecological Lower Midland Zones IV and V Soil, Air, and Land Surface Temperature Variations .....	972
Precipitation Amount, Rate, and Soil Moisture Variations .....	978
Evapotranspiration Variations .....	982
Contribution of GIS and Remote Sensing in Agro-ecological Zone Evaluations .....	984
Climate-Smart Crop Management .....	985
Conclusion .....	986
References .....	987

## Abstract

Food production in Kenya and Africa in recent past has experienced vagaries of weather fluctuations which ultimately have affected crop yield. Farming in Kenya is localized in specific Agro-ecological zones, hence understanding crop growth responses in particular regions is crucial in planning and management for purposes of accelerating adoption. A number of strategies for adoption and adaptation to changing weather patterns have been deployed yet only limited challenges have been partially addressed or managed. This chapter examines previous methods used in classifying agro-ecological zones and further provides additional insightful parameters that can be adopted to enable farmers understand and adapt better to the current

This chapter was previously published non-open access with exclusive rights reserved by the Publisher. It has been changed retrospectively to open access under a CC BY 4.0 license and the copyright holder is “The Author(s)”. For further details, please see the license information at the end of the chapter.

H. Manzi (✉) · J. P. Gweyi-Onyango  
Department of Agricultural Science and Technology, Kenyatta University, Nairobi, Kenya  
e-mail: [gweyi.joseph@ku.ac.ke](mailto:gweyi.joseph@ku.ac.ke)

variable and unpredictable cropping seasons. The chapter scrutinizes past and current documented information on agro-ecological zonal valuations coupled with the use of earth observation components such as air temperature at surface, land surface temperature, evapotranspiration, soil, temperature, and soil and moisture content in order to better understand and effectively respond to new phenomena occurring as a result of climate change in the marginal agricultural areas. Significant variations in precipitation, ambient temperature, soil moisture content, and soil temperature become evident when earth observation data are used in evaluation of agro-ecological lower midland zones IV and V. The said variations cut across areas within the agro-ecological zones that have been allocated similar characteristics when assigning cropping seasons. The chapter summarizes the outcomes of various streams of contributions that have reported significant shifts or changes in rainfall and temperature patterns across Kenya and wider Eastern Africa region. The chapter highlights the need for re-evaluation of the agro-ecological zones based on the recent earth observation datasets in their diversity. The research emphasizes the use of multiple climate and soil-related parameters in understanding climate change in the other marginal areas of Kenya.

---

**Keywords**

Climate change · Length of growth period · Cropping seasons · Earth observation data

---

## Introduction

### Climate Change and Its Impacts in Lower Midland Agro-ecological Zones IV and V

The worrying trends and implication of the changing climatic patterns and extreme weather events have been previously documented (Donat et al. 2013; Schneider et al. 2018). One of the major concerns is the shift in weather patterns and its adverse effect on rain-fed agriculture. Previous work (Pearce 2000; Rosenzweig, and le Parry 1994) have shown the vulnerability of most developing countries to climate change. Seo et al. (2009) evaluated the effects of climate variability in Africa and singled out the semi-arid areas as the most sensitive while the productive areas such as the high to medium wet zones becoming even more useful for agriculture. These researchers highlight the role that agro-ecological zones play to bring out the understanding of climate change and further emphasize the role of climate change on the impact on crops and livestock in light of changing economic value. They further observed that climate resilience is built more on net crop and livestock revenue combined rather than crop or livestock alone, particularly the African region. Mendelsohn (2008) links markets and places the largest economic impact of climate change upon agriculture. Furthermore, studies in developing countries have pointed to challenges in placing the economic value to agriculture due to lack of data on farm performance,

as argued by Mendelsohn (2008). The author draws parallels from tropical and subtropical agriculture and is of the opinion that both regions are more sensitive to climate change compare to temperate zones and that the level of effect emanate more on climate scenarios at hand than agriculture practices or level of farming activities. In addition, the climate variability differs from one country to another and differences are also evident within regions in the countries (Mendelsohn 2008).

Kenya has experienced extreme rainfall events in every 3 years cycle on average based on the 1989–2011 analysis (Ndirangu et al. 2017). In the same period, severe droughts and changes in rainfall variability have become inevitable. These have severely affected farmers who depend on rain-fed agriculture and have eventually become victims of climate variability and extreme weather events. Furthermore, the global financial and economic crisis have made the situation worse through the disruption of agricultural supply chains and market, weakening the ability of the agricultural sector to address food security. Despite intervention in agriculture, crop, and livestock production system are still sensitive to drought and other extreme weather events especially in arid and semi-arid areas as indicated by Ndirangu et al. (2017). This confirms the existence of fragile local mechanism for coping and poor resilience to cushion against future climate change shocks. Ochieng (2015) discusses the impact of climate change on agricultural production and considers rainfall and temperature has having positive effects on the revenues of most crops. Fluctuation of temperature and rainfall in growing seasons is known to cause serious problems in normal plant processes, hence crop losses are inevitable. The findings by Ochieng (2015) stressed the significance of the longstanding effects of climate change in terms of temperature changes to have an adverse effect on crop production compared to interim effects. The impacts of temperature in this respect significantly override those of rainfall fluctuations. Fischer (2006) predicted that the global warming phenomenon would lead to higher temperatures and modify precipitation levels which to far extent have had an impact on the productivity of land suitable for agriculture. These are some of the current events being experienced in countries such as Kenya. He further concluded that the integration of agro-ecological zonal methodologies and socioeconomic models could provide right tools for land use planning and resource development.

Farming in most parts of Africa, Kenya included, revolves around agro-ecological zones. It is the *agro-ecological* zones as defined by FAO (1978) and improved by Jiitzold and Kutsch (2000) through the farm management guidelines that determine where crops can be suitably grown. In this agro-ecological zones, cropping seasons have been identified based on the length of growing periods. In addition, FAO (1978) defines agro-ecological zoning (AEZ) as the use of soil parameters, natural features, and climate characteristics to demarcate areas potential for agricultural production. The particular parameters used in the agro-ecological zoning and cropping pattern assign more focus on the climatic and soil, chemical, and physical parameters and their requirements by crops and on the management systems under which the crops are grown. Each zone has a similar definition to ensure its suitability to support certain functions. This kind of evaluation calls for certain recommendations designed to improve the existing land-use suitability situation, either through increasing advocacy for production or by barring use due

to land degradation. Moreover, the studies on agro-ecological zoning put emphasis on the use of FAO classification of 1978 which looks at the ability of agricultural land to support crop production through length of growing period, temperature, and precipitation. According to FAO (1978), this length of growing period is understood to be the period where rainfall and stored soil moisture is greater than half of the evapotranspiration. This, therefore, simply means the longer the growing season, the more the plants to be planted, the longer the period for plant carbon fixation, and the higher the yields. Vrieling et al. (2013) indicate that the length of growing period is analyzed based on weather station data, which are unfortunately quite scarce in Africa or depend coarse rainfall satellite data that are not reliable. The findings reported by Vrieling et al. (2013) clearly show that there are high variability in length of growth period in arid and semi-arid areas. This is further confirmed by the high crop failure rate in the same regions.

Length of growth periods derived from earth observation data such as GIMMS Normalized Difference Vegetation Index generation 3 (NDVI3g) dataset provided useful information for mapping of farming system as well as study of climate variability. The other option for assessing the length of growing periods is documented elsewhere (De Beurs and Henebry 2010; White et al. 2009) and consider use of time-series remote sensing data. The remote sensing methods have been found to be convenient in providing useful information for understanding cropping patterns especially at the start and end of seasons. If such information is properly harnessed can provide early warning systems that can be leveraged on for efficient planning. Henricksen (1986) discussed the need for proper definition of agro-ecological zones in Africa. According to him, it would enhance the ease in collecting and updating agro-ecological data and further give a better latitude for proper definition of the cropping seasons.

The role of agro-ecological zone in defining the crop environment in Kenya, has been generated from the agro-climatic zones. An agro-ecological zone is therefore defined by its relevant agro-climatic factors, especially the moisture supply and differentiated as well by soil patterns. The aim is to provide a frame-work for the natural land use potential. The main zones are therefore differentiated by their ability to provide temperature and water requirements for the specific crops in that particular agro-ecological zone. This is related to the climatic yield potentials as calculated from the computer. Once these zones are established, they are comparatively run alongside the Braun's climatic zones of the precipitation/evaporation index as shown by Le Page et al. (2017). The comparability is expected to have variances due to the influence of the length and intensity of arid periods, a factor that has also to be considered. New agro-ecological zoning methodologies have been done and found to be effective in assessing crops against climate vulnerability (Le Page et al. 2017).

Climatic changes have caused drastic weather patterns over the years where more consideration other than length of the growing period are needed. The current length of growing periods are characterized by intensive precipitation whose distribution is poor while at the same time high temperatures are experienced in-between period of precipitation cessation. Inclusion of earth observation data, therefore, becomes very critical in understanding developing climate variability within the existing

agro-ecological zones and thereafter necessitating technologies that can accommodate significant changes. Earth observation data and remote sensing technologies have improved and hence provide near real-time observations. Moreover, the placement of rain gauges which determine the precipitation data is sparse and may not reflect microclimatic changes that have occurred over the years as argued by Vrieling et al. (2013). The evaluation of agro-ecological zone focuses on changes in precipitation, temperatures, and soil characteristics which have necessitated the interpretation of changes in growing periods over the years using earth observation data. Furthermore, there has been a pressing need to adapt climate-smart crops for the various regions in Kenya. Coincidentally, climate-smart crop management in the twenty-first century is the new paradigm shift that may be panacea to majority of rain-fed smallholder farmers to cope with climate change. This chapter therefore calls for use of earth observation data such as soil surface moisture data, varied temperature parameters, varied precipitation parameters, and other relevant parameters that can enable the evaluation of cropping seasons based on gridded variation found within the agro-ecological zones from earth observation datasets.

Previous studies have shown that rainfall levels are bound to decrease, increase, or remain the same under most climate scenarios albeit with a lot of extremes in some scenarios, while the temperature are likely to increase. It is these impacts and implications of such reports that have necessitated the need to reevaluate the agro-ecological zonation and infer whether there any significant changes in the growing periods. Ayugi and Tan (2019) revealed a rise in temperature which might contribute to hydrological droughts in the arid and semi-arid areas in future. Additional information have pointed out the need to analyze for specific trends and thereafter characterize areas in terms of vulnerability to climate, particularly the semi-arid areas of Africa, Kenya included. King'uyu et al. (2000) noted significant changes over the surface temperature based on data collected in 71 stations for the period 1939–1992 in Eastern Africa. Unfortunately, geographical variability in nighttime temperature was difficult to interpret thereby calling for further research. Nsubuga and Rautenbach (2018) did a review of climate change and variability in Uganda and confirmed a growing trend in changes in temperature and rainfall and, moreso, in the Eastern Africa region where Kenya and Uganda lie. Hastenrath (2001) and Schreck and Semazzi (2004) have also done extensive work on climate change in East Africa and significantly provided information on changes in weather patterns over years. These reviews of scientific research findings have created a better understanding of the recent climate changes and variabilities in Kenya and provide further information for use in future research and adaptive actions.

The use of earth observation data in climate change monitoring cannot be overemphasized. Earth observation data have provided important insights into important parameters such as biological, physical, and chemical in its bid to address climate change needs and adaptation strategies (Guo et al. 2015). The capacity of earth observation data is advanced in terms of temporal and spatial scales. The complexity in the study of climate change in the aspects of atmosphere, oceans, and lands, make earth observation data an important option as stressed by Guo et al. (2015). The launch of various datasets by NASA and their availability to near real

time open a huge platform for addressing climate change issues in Africa. The current chapter attempts to integrate a number of these options to give insights to climate-smart agricultural option in these fragile agro ecological zones IV and V with an aim of providing strong adaptation and adoption strategies to variable weather and cropping seasons.

This chapter focuses on the agro-ecological zones IV and V of the marginal lands of Tharaka-Nithi, Meru, Makueni, and Machakos counties that run along a similar agro-climatic belt in Eastern Kenya. These areas cover semi-arid region where most farmers depend on rain-fed agriculture for livelihood. These areas are characterized by crops as such green grams, sorghum, millet, and pigeon peas. Agro-ecological zones IV and V are classified as a Lower Midlands that are found in semi-arid areas (FAO 1996). According to FAO (1978), the various cropping patterns in the two rainy seasons are evaluated as having the following characteristics:- very short to short and very short cropping seasons, very short to short and very short to short cropping seasons, very short to very short to short cropping seasons, two very short cropping seasons, very uncertain and very short to short cropping season, and finally very uncertain and very short cropping season for Tharaka Nithi. Part of Meru that form part of the agro-climatic belt of Tharaka-Nithi have similar cropping pattern. Machakos' lower midlands zone V is also characterized by very short and very short to short cropping seasons, very short and very short cropping seasons, and finally very short to short and very short to short cropping seasons. Kitui, on the other hand, has very short to short and short to very short cropping seasons, very short and very short cropping seasons, very uncertain and short to short cropping seasons for both zones IV and V (Jiitzold and Kutsch 2000). The average rainfall and temperatures for Tharaka Nithi, Meru, Makueni, Kitui, and Machakos lower midland zones IV and V as documented by the farm management hand book of Kenya is illustrated in Table 1. Illustration of the these zones are also shown in Fig. 1.

### **Earth Observation Products in Climate Change Monitoring**

Time average, soil moisture content underground, land surface skin temperature, multiyear monthly mean surface temperature, air temperature, total precipitation flux, total surface precipitation flux, total surface precipitation, precipitation rate, combined gauge precipitation, monthly precipitation, climatology rainfall flux, and monthly evapotranspiration for varied periods products were obtained from earth observation Geospatial Interactive Online Visualization and Analysis Infrastructure (GIOVANNI) NASA web portal. The products used were precipitation rates in mm/day with a spatial resolution of 0.25° for the period 1998–2019. Precipitation rates here refers to rainfall intensity. Another product used was amount of precipitation on monthly basis recorded as mm/day for the period 1998–2017 packaged as time average maps at 0.5° spatial resolution. Thirdly, soil moisture content underground at 0–10 cm, 10–40 cm, and 40–100 cm was also evaluated. The products were obtained from NOAA through the GLDAS model for the period 2000–2019. Alongside these, the soil temperature at 0–10 cm, 10–40 cm, and 40–100 cm was obtained from Atmospheric Infrared Sounder (AIRS)/National Oceanic and Atmospheric Administration (NOAA) products for the period 1998–2014 at 0.25° spatial

resolution. Another temperature parameter examined was the products of air temperature at surface day time and night time as obtained from AIRS/STM for the period 2002–2016 at 1° spatial resolution. Further products on evapotranspiration from NLDAS/MOSO for the period 1998–2014 at 0.25° spatial resolution. The dataset used for this study are general time average maps for periods not less than 10 years to bring various phenomena of variation in the area of study. These phenomena are meant to provide current insight into climate change variability and influence in agro-ecological lower midland zones IV and V. The remote sensing product analyses were done using QGIS, Terrset software, and other GIS software. This was to get current status of the agro-ecological lower midland zones IV and V and whether there are any indications that can lead to change in cropping season and suitability of crops. Other products examined include time average products on amount and distribution of the precipitation as compared to studies done by Jitold

**Table 1** Characterization of lower midland zone V based on cropping season, annual temperature, and annual average rainfall – Jatzold and Kutsch 2000)

Name of the county	Agro-ecological zones IV and V	Cropping season in the two rainy seasons	Annual mean temperature in °c	Annual average rainfall in mm
Tharaka Nithi and Meru	V	Very short to short and very short to short	24–22.9	800–900
		Very short to short and very short		Too small
		Very short and very short to short		750–870
		Very short and very short		650–850
		Very uncertain and very short to short		630–660
		Very uncertain to very short		600–700
	IV	Short to very short and short to very short	23.5–21.0	820–920
Machakos and Makueni	V	Very short to short and very short to short	24–21.6	650–750
		Very short and very short to short		600–800
		Very uncertain and very short to short		600–700
		Very uncertain to very short		690–700
		Very short and very short		No data

(continued)

**Table 1** (continued)

Name of the county	Agro-ecological zones IV and V	Cropping season in the two rainy seasons	Annual mean temperature in °C	Annual average rainfall in mm
	IV	Short to very short and short to very short	22.0–21.0	700–850
		Very short to short and short to very short		700–800
Kitui	V	Very short and very short to short	24.0–23.0	650–790
		Very short and very short		600–780
		Very uncertain and very short to short		600–750
		(Very short) and very short		600–650
		Very uncertain and very short		550–630
	IV	Short to very short and short	24.0–20.9	800–1000
		Very short to short and short to very short		750–880
		Very short and short to very short		700–820
		Very uncertain and short to very short		720–820

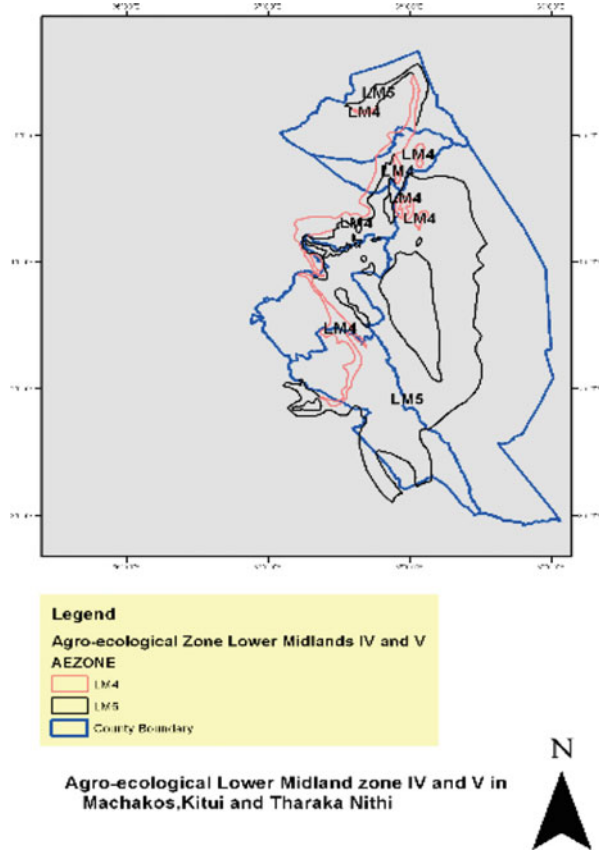
and Kutsch (2000) that are mostly used for national policy planning on cropping season in Kenya through the farm management guideline books.

### **Climate Variability in Agro-ecological Lower Midland Zones IV and V Soil, Air, and Land Surface Temperature Variations**

This chapter gives a brief overview of air temperatures, land surface temperature, and multiyear land surface skin temperature daytime for the period 2000 to 2016 that depict an upward trend in temperature changes (Figs. 2 and 3, respectively) for zones IV and V. These areas that include parts of Makueni and Kitui show temperatures of between 26 °C and 31°C while Machakos, Tharaka, and parts of Meru have temperature ranges of 24–26°C. These temperatures changes compared closely with those earlier reported by Jiitzold and Kutsch (2000) (Table 1) with annual average temperature ranges of 22–24 °C for Machakos, Kitui, and Makueni indicating an increasing trend in temperature. Tharaka Nithi and parts of Meru temperature fluctuate between 24–26 °C and 22–24 °C, respectively. The trend of temperature



**Fig. 1** Agro-ecological lower midland zone IV and V in Machakos, Kitui and Tharaka Nithi



variations confirms reports by previous studies (Nsubuga et al. 2014; Omondi et al. 2014), an indication of increase in temperature trends and variability over East Africa. The challenge of variations from one locality to another as highlighted by Omondi et al. (2014) may be solved through having gridded earth observations data. Earth observation data provide spatial resolution smaller compared to data collected from various in situ stations whose spatial resolutions are usually very wide due to unavailability of adequate and well-distributed weather or radar station in Kenya. There are pockets of temperature variations as shown on the time-average maps of air temperature for the period 2002–2016 which is a 14-years-period for both daytime and nighttime (Fig. 2). This is an indication that over the years, different areas within the agro-ecological zones of lower midland IV and V have experienced climate variability in terms of temperature changes. This may also imply that the length of growing periods of crops are different within the same zone. Vrieling et al. (2013) is of the opinion that the distribution of crop and farming systems go hand in hand with the length of growing period. They further note that length of growing period in Africa (Kenya included), have been determined by weather station data with poor spatial distribution.

Climate change over the years has been studied and confirmed to cause a fluctuation in the length of growing periods as shown by Gregory et al. (2005). Moreover, Ayugi and Tan (2019) brings out the importance of surface air temperature as one of the parameters to be considered and blends well with the current finding in regard to agro-ecological lower midland zone IV. Ayugi and Tan (2019) further highlights the significant role of this type of products in the assessment of climate change variability for interpretation of the overall climate state in Kenya. His observations depict a trend of increasing temperatures in the period between 1971 and 2010. Similar inferences are drawn from the earth observation climate products for air temperature at surface for the period 2002 to 2016 in the similar areas. The air temperature at surface (Fig. 2) varies significantly within the agro-ecologies of lower midland zones IV and V. These datasets if generally compared to data by Jiitzold and Kutsch (2000) in Table 1 are possible to infer that there is an increasing trend in temperature. Rise in temperatures were predicted to increase between 1 °C and 2.5 °C on average, with a predictive temperature change in 2020 being between 1 °C and 2 °C for 2030 and 2.5 °C for 2040 (Eitzinger et al. 2011). These predictions are likely to change crop suitability for various regions as further argued by Eitzinger et al. (2011) based on research that displays maps with changing suitability of tea growing area in Kenya. He further cautions that areas between 1400 and 2000 meters above

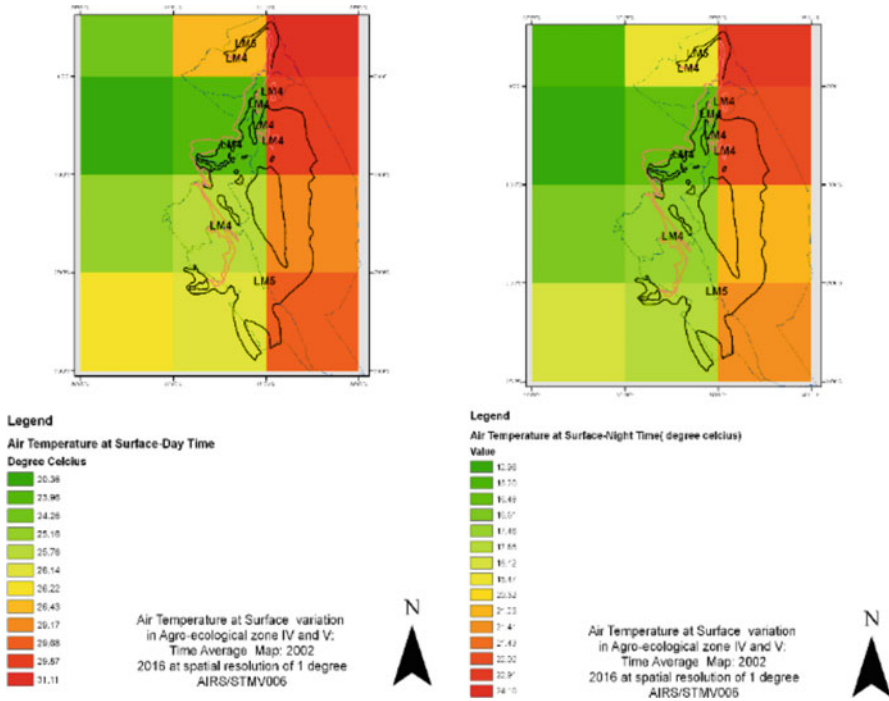


Fig. 2 Air temperature at surface variation in agro-ecological lower midland zone IV and V

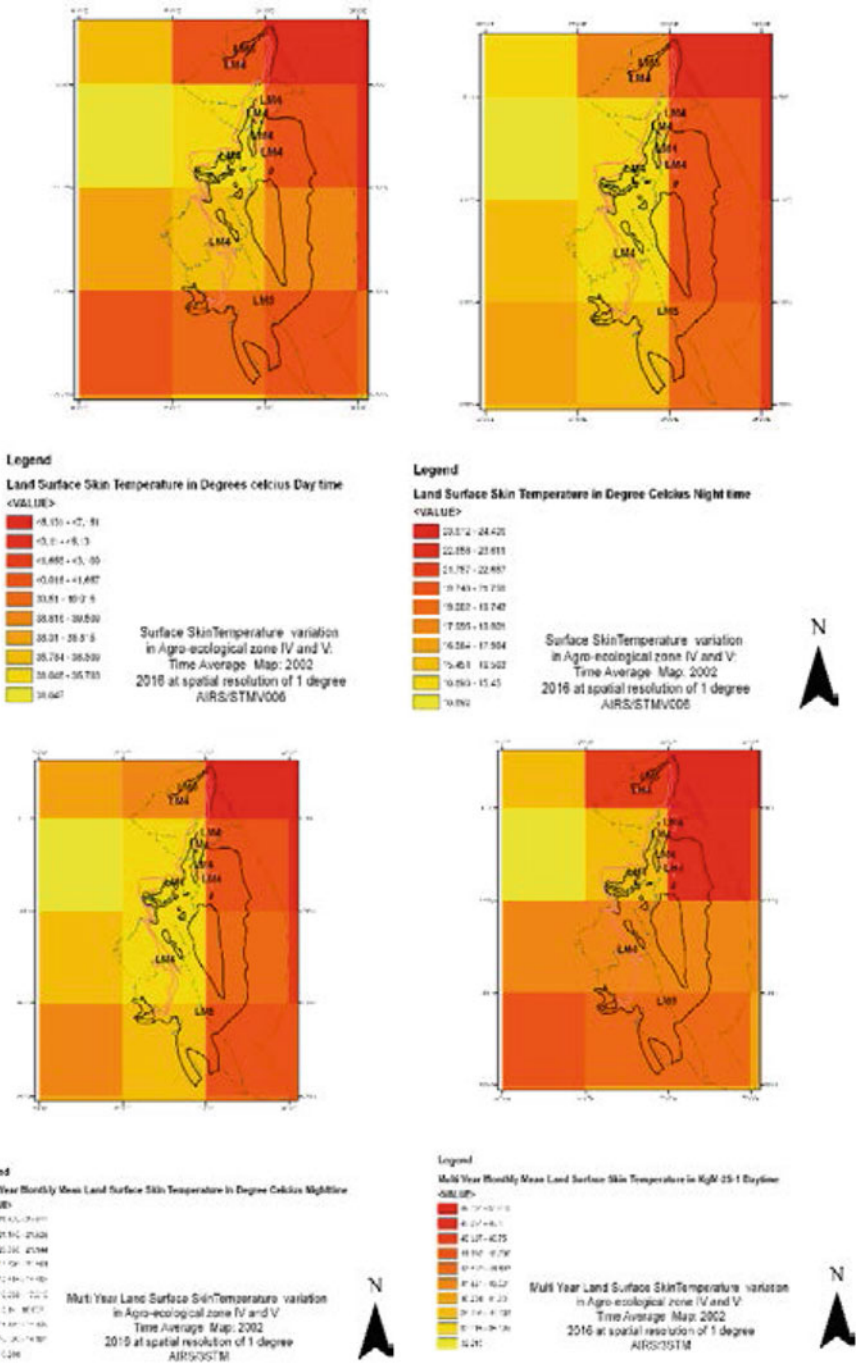


Fig. 3 Land surface skin temperature variations in agro-ecological lower midland zone IV and V

sea level are likely to be regions that will experience the highest changes in suitability for crops.

Additionally, this chapter made effort to deeply make observations on monthly Land surface skin temperatures for the period 2002–2016 at 1° spatial resolution to further improve on understanding of the analysis. Figure 3 shows significant variations within the agro-ecological lower midland zones IV and V. Such variability in land surface temperatures in any area is a manifestation of variation of vegetation responses to water stress (Sun 2009; Pinheiro et al. 2006). Land surface temperature has been confirmed to be a very important parameter for environmental as well as climate studies (Pinheiro et al. 2006). It is also important to note that currently, weather stations provide limited data on spatial patterns of temperatures over large areas as shown by Assiri (2017). This leaves interpretation of the land surface temperatures from satellite imagery a viable option. It would, therefore, be prudent to argue that land surface temperature is a key parameter in understanding crop water stress within any agro-ecological zone.

The significance of land surface temperatures in climate monitoring cannot be ruled out in the extreme weather event scenarios as reported by Sun (2009). Furthermore, Vlassova et al. (2014) emphasize land surface temperature as an important parameter in soil-vegetation transfer modeling in most terrestrial environments. This parameter becomes even more important in evaluating cropping seasons and assessment of length of growing periods in such areas. Time average maps of multi-year monthly daytime and nighttime land surface temperatures for the period 2002–2016 are also presented for agro-ecological zones IV and V (Fig. 3). Evidently, there are significant variations across the entire agro-ecological lower midlands zones IV and V area as also confirmed by the monthly daytime and nighttime temperatures for the same period. Assiri (2017) demonstrated high correlation between moderate resolution imaging spectroradiometer (MODIS) satellite nighttime land surface temperature which also had high correlation with station-based minimum temperatures as compared to the daytime land surface temperatures. The accuracy and effectiveness of MODIS land surface temperature was further corroborated by those of Kenawy et al. (2019). Apparently, Sun (2009) showed that land surface temperature uses/values to be quite wide and included but not limited to hazard prediction, water management in agriculture, crop management, in terms of crop stress monitoring and yield forecasting and nonrenewable resource management. In addition, the authors provide contribution to work done regarding assimilation of land surface temperatures in soil moisture monitoring through the surface energy balance assimilation scheme.

This chapter also makes observations on soil temperatures for 0–10 cm, 10–40 cm, and 40–100 cm for the period 1998–2014 at a spatial resolution of 0.25° since the focus of understanding agro-ecological zones currently suitable for certain crops and the cropping seasons. These products do not seem to show significant differences among the various soil depths (Fig. 4). This could probably be attributed to vegetation cover, an important element in thermal conditions of soils (Holmes et al. 2008). This condition has the ability to influence the vertical differentiation of soil temperatures as previously revealed by Skawina et al. (1999). What was striking is

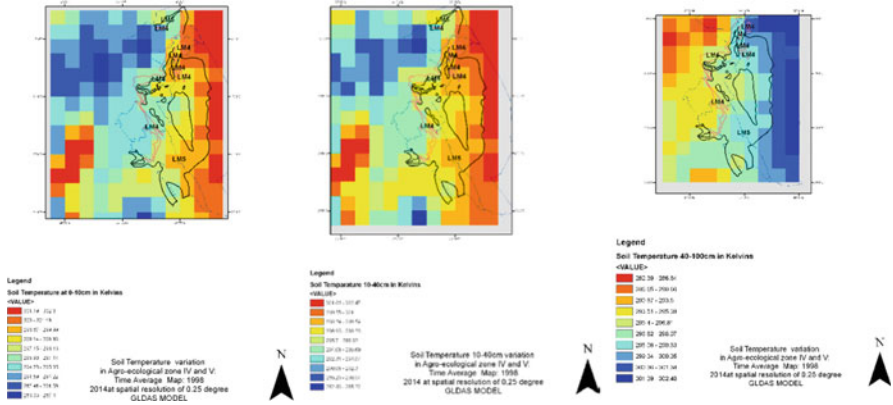


Fig. 4 Soil temperature variations in agro-ecological lower midland zone IV and V

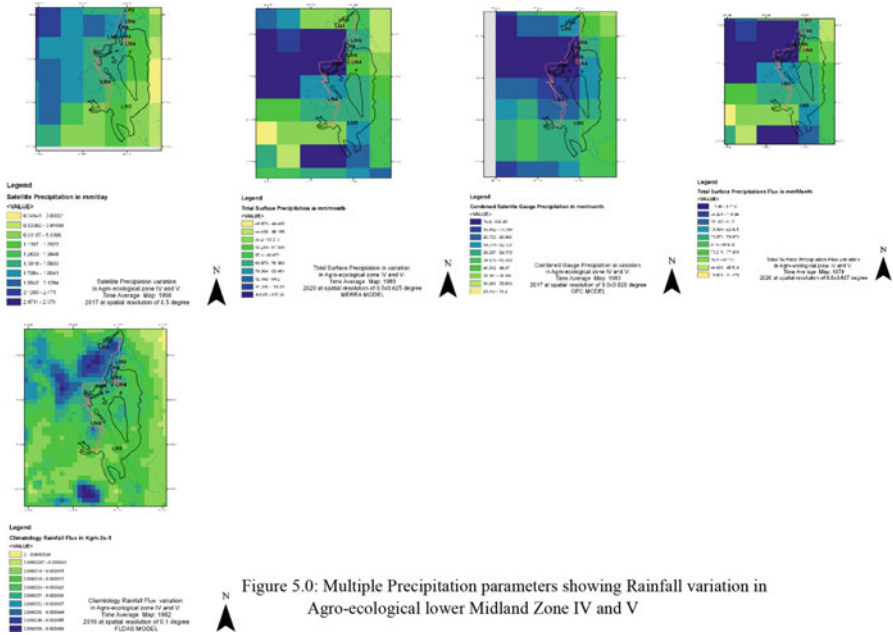


Figure 5.0: Multiple Precipitation parameters showing Rainfall variation in Agro-ecological lower Midland Zone IV and V

Fig. 5 Multiple precipitation parameters showing rainfall variation in agro-ecological lower midland zone IV and V

the significant variation identified within the agro-ecological lower midland zones IV and V with the soil temperatures varying across Makueni, Machakos, Tharaka Nithi all the way to the small parts of Meru, i.e., the ranges are 26.85–22.85, 20.85–24.85, 24.85–26.85, and 17.85–23.85, respectively, for all areas (see Fig. 5). These observations summarize quite significant and clear changes that have been taking

place within the zones over a long period as result of climate variability and extreme weather events. Similar observations have been reported before by Buckman and Brady (1971) who stressed the significance of soil in agriculture since it is the medium upon which crops are grown. They confirm that significant chemical and biological reactions begin when certain temperatures are optimal in the soil media. Moreover, Skawina et al. (1999) demonstrated the significance of weather conditions on the thermal properties of soil. This, therefore, means that significant climate variability influence soil temperatures positively or negatively and thereby affecting crop growth.

Soil temperature parameters therefore become extremely important factors to consider in agro-ecological zone characterization as shown by studies of Osińska-Skotak (2007) who reported that soil temperatures were influenced by meteorological situations taking place. Onwuka (2018) confirms that soil temperatures are affected by environmental factors especially by controlling the heat on the soil surface and heat dissipated from the soil down the profile. The importance of soil temperature cannot be overemphasized in this chapter. Indeed Sabri et al. (2018) showed that biological processes such as seed germination, seedling emergence, plant root growth, and the availability of key nutrients are components dependent on soil temperature, moreso the transmission of water inside the plant. In addition, injuries in the plant tissue at root zone can occur as a result of fluctuation in temperatures (lower or higher) as attested by Decker (1955). This could imply that soil temperatures fluctuation could be the reason for high soil-borne diseases due to injury of plant tissues. It could also be the explanation for high soil-borne disease incidences associated with climate change. Schollaert Uz et al. (2019) documents the role that remote sensing datasets can play in linking different climatic variability events to pest and disease incidences. In this chapter, the coupling of crop models to pest and diseases model together with climates are considered as new frontiers to enabling monitoring of pests and diseases outbreaks under extreme weather events for early preventative measures.

---

## Precipitation Amount, Rate, and Soil Moisture Variations

Several earth observation products modeled for precipitation analysis were used in this chapter for understanding variations within the agro-ecological lower midland zones IV and V as shown in Fig. 5. The first product we considered was the average time maps for precipitation monthly for the period 1998–2017 (recorded in mm/day) at spatial resolution of  $0.5^\circ$ . This revealed variations in precipitation amounts within these areas. The amounts varied across the areas in consideration with Kitui and Makeni showing a range between 1.39 and 0.9 mm/day, while Machakaos had precipitation amounting to 1.59–1.89 mm/day and Tharaka Nithi and Meru exhibiting 1.39–1.89 mm/day and 1.26–1.59 mm/day, respectively. Another product of interest that observed was the total monthly surface precipitation in mm/day for a spatial resolution  $0.5 \times 0.625^\circ$  for the period 1980–2020. This product also showed significant variation within the agro-ecological lower midland zones IV and V where

places like Makueni and Kitui showed precipitation amounts of 63.67–44.43 mm/month with small pockets showing higher precipitation amounts of 70.36–82.49 mm/month. Machakos area had rainfall ranges between 70.36 and 94.2 mm/month with some small areas to the North East experiencing precipitation amounts of 94.2–118.04 mm/month. Finally, Tharaka Nithi and parts of the drier Meru experienced precipitation amounts of 70.36–118.04 and 53.4–48.2 mm/month, respectively. The combined satellite gauge precipitation monthly in mm/month at spatial resolution of  $0.5^\circ$  for the period 1983–2017 also formed an interesting observation set. There were clear and interesting variations on precipitation amounts within the agro-ecological lower midland zones IV and V. This product specifically showed 49.17–62.72 mm/month for Makueni and Kitui, while for Machakos the precipitation ranges between 69.96 and 101.61 mm/month. Tharaka Nithi and Meru show precipitation amount of 59.77–101.61 mm/month with a small area to the northeast showing 41.51–49.17 mm/month. Finally, the time average maps of climatology of rainfall flux monthly for the period 1982–2016 at spatial resolution of  $0.1^\circ$  in  $\text{Kg/m}^{-2}/\text{s}^{-1}$  was also observed. The observation pointed to the fact that substantial variations existed within the area of the agro-ecological lower midland zones IV and V. All products showed a significant rise in precipitation amount for areas, especially Makueni, Kitui, and Machakos. We observe that these areas have experienced gradual increase in rainfall amounts in some pockets, e.g., Machakos as compared to earlier reports by Jiitzold and Kutsch (2000), implying a rising trend. On the contrary, Makueni and Kitui areas seem to register a downward trend in precipitation (see Fig. 5 and Table 1). Over the years, these semi-arid regions have been described to be regions of limited precipitation (Slatyer and Mabbutt 1964). However, Managua (2011) had conflicting views, indicating a rise in rainfall for the period 2020–2050 for most parts of Kenya. These scenarios of high unprecedented rainfall are currently being experienced in Kenya.

Precipitations in the marginal areas have been described to undergone considerable positive change, indicating trends of increasing rainfall amounts in some pockets. Other studies have reported conflicting (negative trends), indicating the failure to include the changing Indian Ocean weather patterns; – something that may affect climate data modeling along semi-arid regions as argued by Herrero et al. (2010). Vrieling et al. (2013) gave a comprehensive descriptive dataset on changes in weather patterns which showed an increasing trend in the dry period between the short and long rains and this has been happening at the expense of short rains. Interestingly, Elbasit et al. (2014) has also demonstrated that there is a good agreement between satellite Tropical Rainfall Measuring Mission (TRMM) 3B43 products and the monthly rain gauge information, confirming increasing trend in rainfall and the reliability on Tropical Rainfall Measuring Mission (TRMM) earth observation products for climate monitoring.

The variations observed and scenarios of higher precipitations in some part of the agro-ecological lower midlands zones IV and V call for future evaluation of the cropping season as well as the length of growth periods. The proper and reliable estimation of onset and cessation of precipitation is critical in rain-fed agriculture in the semi-arid areas as emphasized by Fiwa (2014). Incidentally, existing information

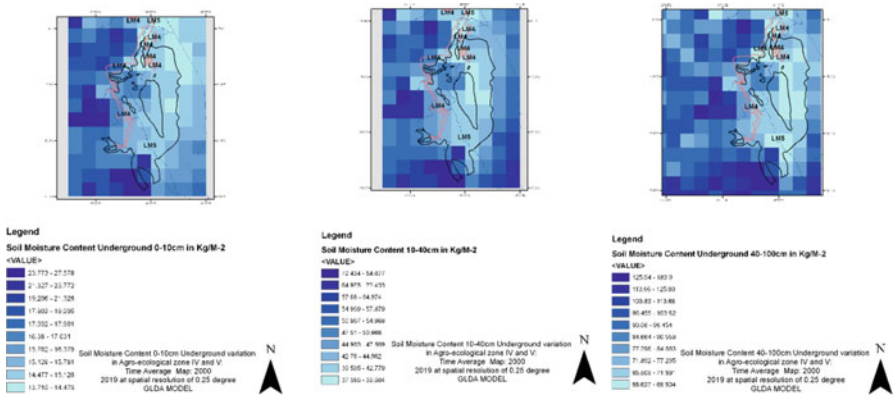
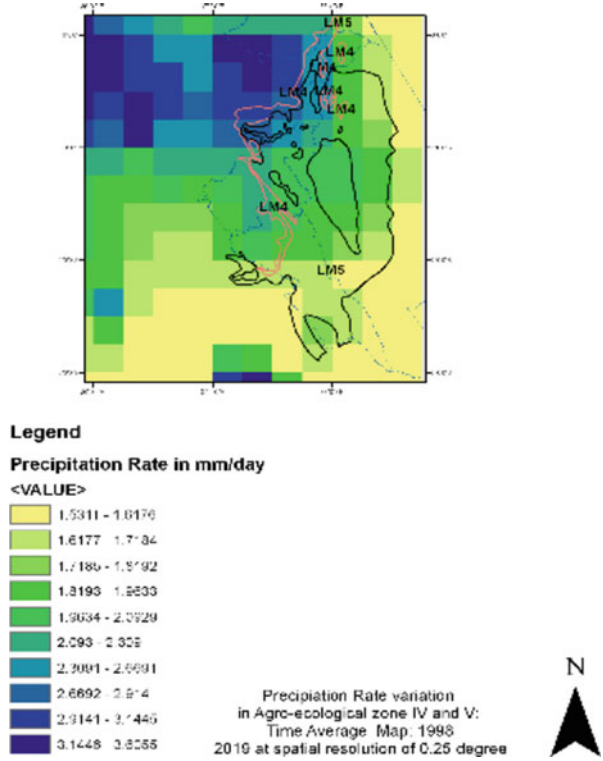
shows that the relationship between precipitation onset, cessation, and length of growing period becomes very important in the planning of agricultural activities especially among smallholder farmers in Africa (Fiwa et al. 2014). In this chapter, therefore, we are of the opinion that there is an upward increase in precipitation in these marginal areas and but the absolute increase the precipitations have vast variability. Aming et al. (2014) also identified precipitation extremes and higher variabilities in arid and semi-arid parts of Africa, the findings which seem to be in line with our observations in these agro-ecological lower midland zones IV and V of Kenya. Fluctuation and variations in the rainfall have also been confirmed by Camberlin (2009) with indications showing serious variations from one weather station to another, especially in the long rains of East Africa. The growing developments in satellite-based rainfall assessments provide a cheaper alternative to rainfall data that is available for free online (Kumar and Reshmidevi 2013). The collection of rainfall data using passive or active remote sensing techniques has a potential to bring a more informed way of handling climate change in Africa and moreso Kenya with huge landmass represented by arid and semi-arid regions. These methods of rainfall data collection can be described as brightness temperature for passive method (Hengl et al. 2010) and attenuation of the radar power at several heights to estimate surface rain for the active method (Skolnik 1962; Meneghini et al. 1983; Hengl et al. 2010).

Rainfall intensity from earth observation data is known to show variations within the agro-ecological lower midland zones IV and V (Fig. 6). Higher precipitation rates are associated with areas of high precipitation as shown in Fig. 6. High precipitation rate is associated with runoff and hence low soil moisture content (Mutiga et al. 2013). This further affects the length of growing period and expected cropping seasons. Notably, high runoff is associated with low productivity of soil and causes severe risk in agriculture as result of climate hazard (Gatot et al. 2001). Furthermore, it is known that soils experiencing high runoff as result of high rainfall intensity are normally very low infertility due to the percolation of soil nutrients. Rainfall intensity monitoring in agro-ecological zone of marginal areas of Kenya is key since high level of runoff in the semi-arid areas are highly associated with precipitation rates as well as poor farming practices. Fiwa et al. (2014) asserts that rainfall intensity monitoring using weather satiation is a real challenge across Africa. Thies (2008) evaluated rainfall intensity data from satellite imagery differentiation techniques and concludes that they offer potential for improved rainfall rate. This allows for spatiotemporal near real-time information on rainfall distribution. This kind of data and techniques in Africa will definitely address the challenges facing climate-smart crop management under extreme weather events whenever they will be fully available.

Additional products considered included soil moisture content below the ground at 0–10 cm, 10–40 cm, and 40–100 cm, soil temperatures at 0–10 cm, 10–40 cm, and 40–100 cm, see (Fig. 7). These additional products provide information on moisture availability for the various crops within the agro-ecological lower midland zones IV



**Fig. 6** Daily precipitation rate variation in agro-ecological lower midland zone IV and V



**Fig. 7** Soil moisture content underground variations in agro-ecological lower midland zones IV and V

and V. This chapter makes a contribution on knowledge on increased variability in soil moisture content across the entire study area. This can be attributed to the diverse variance in soil types and soil characterizes as well as canopy cover. This can also be related to the various changes in climatic;- soil related weather parameters. Other factors affecting soil moisture contents are human-induced activities that cause land degradation (FAO 2002). Degraded soils have very low water retention capacity hence low soil moisture content. The role that soil moisture content plays in crop development cannot be overemphasized. Every crop requires good soil moisture content to stimulate activities between the shoot and the root zone. Soil moisture contents are identified as key factor determining length of growth period which impact on cropping seasons and crop suitability in any agro-ecological zones.

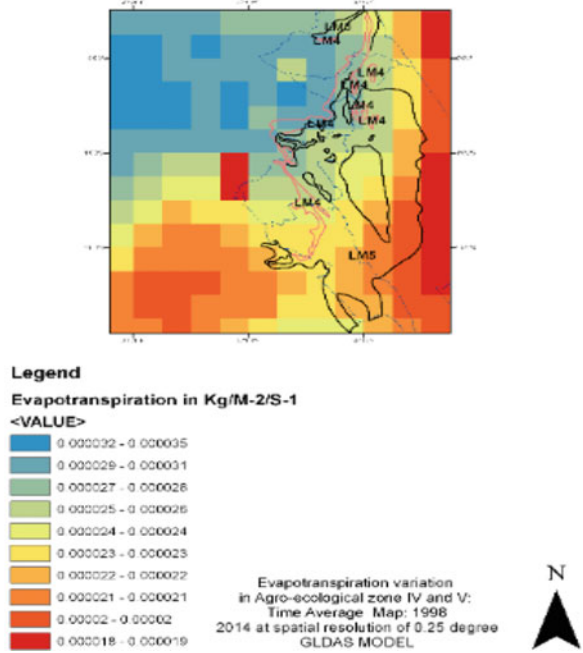
Kamara and Jackson (1997) states that soil moisture is a better indicator of water availability to the crop than rainfall amount. Improved soil moisture management can only take place when analysis of soil moisture content are carried out and are well understood. Understanding soil moisture content scenarios assist in working toward high water retentions in the soil which eventual reduction in soil runoff in some cases. In semi-arid regions, the issue of soil moisture becomes very important since moisture stress in crop is one of the key determinants of crop failure. In other studies, Pellarin et al. (2020) has shown that soil moisture content can be used to infer precipitation using PRISM Model. This kind of modeling is said to provide useful information concerning crop yield estimates and irrigation demands over large areas. In his research, comparison made with weather station information showed that there was high correlation proving the significance and the role that soil moisture content below ground plays in understanding shifting precipitation patterns. Overall soil moisture content is vital in understanding cropping season, i.e., low soil moisture levels are indications of declining length of growing period for crops. The biggest challenge identified by this chapter is existence of many soil moisture algorithms and products that cannot be compared to other parameters such as precipitation as propounded by Pellarin et al. (2020). He further indicated the need for analysis that can integrate other parameters such as precipitation for the proper validation of satellite soil moisture and also system that can determine the relationship between different soil moisture products.

---

## Evapotranspiration Variations

The other parameter that this chapter observed is evapotranspiration. The monthly evapotranspiration earth observation reported here are for the period 1998–2014 at spatial resolution of 1° and recorded in  $\text{Kgm}^{-2} \text{s}^{-1}$  (see Fig. 8). The values indicated a variation in evapotranspiration across the agro-ecological lower midland zones IV and V area. There were no products for comparison with previous periods in order to understand any changes in evapotranspiration. Areas like Meru agro-ecological lower midland zones IV and V revealed higher evapotranspiration rates. This could be explained by high vegetation cover known to be in this region and high soil moisture content. Evapotranspiration is directly related to soil moisture content and

**Fig. 8** Evapotranspiration variation in agro-ecological lower midland zone IV and V



atmospheric moisture demand (Fischer et al. 2008). Further Fisher et al. (2008) shows that soil moisture is as a result of precipitation while atmospheric moisture emanates from radiation that is controlled by surface and atmospheric temperatures.

Areas in Kitui and Makueni experience very low Evapotranspiration, which could also be due to low vegetation covers that are characteristic of these areas. These indicate that areas of high evapotranspiration rates are likely to have longer growing period. Table 1 classifies these areas and reveal that they have similar short cropping season as those with very low evapotranspiration rates. Evapotranspiration as shown by studies of Jiitzold and Kutsch (2000) shows variations in the length of growing periods which eventually determine the cropping seasons. In this case, the evapotranspiration employed statistical methods of Penman & McCulloch with albedo for green grass being 0.2; McCulloch (1965). This is not to imply its inadequacy but rather the need for improvement. Liou and Kar (2014) confirms that evapotranspiration at a global or regional scale can be done by combining surface parameters obtained from remote sensing data and surface meteorological variable and vegetation characteristics. Marshall and Funk (2014) describes evapotranspiration as an important component in the energy, water, and geochemical cycles that influence climate properties and further says that its interaction with drivers of climate change remain unexplored in Africa.

A combination of a number of parameters and variables in a climate change scenario is likely to improve evapotranspiration analysis and interpretation. This

would further improve on the assessments of cropping seasons. Marshall and Funk (2014) in his discussion points out the usefulness of satellite imagery in representing important characteristics of evapotranspiration over Africa. Similar results have been reported by Dai (2010) who showed rising temperatures in Africa and a decreasing evapotranspiration as result of low precipitation and low soil moisture content. Satellite imagery products through available remote sensing techniques can enhance the availability of spatial and temporal datasets of Normalized Difference Vegetation Index (NDVI), Leaf Area Index (LAI), fraction of incidence sunlight that reflects, surface radiations, and radiometric surface temperatures that are indirectly related to evapotranspiration (Liou and Kar 2014). Further Henricksen (1986) present extensive report on the length of growing period model that was used that seem to work well in drought simulations in Africa. He pointed out the inability of the model to analyze moisture level below 1 month and the assumption of the model concerning runoff and deep percolation.

---

## **Contribution of GIS and Remote Sensing in Agro-ecological Zone Evaluations**

The suitability of gridded climate indices in monitoring climatic variation is demonstrated in Donat et al. (2013) studies. The gridded climatic indices can enable near real-time monitoring of events as well as their placement for long-term use at both global and regional scales. Boitt et al. (2014) in his studies on the impact of climate change on agro-ecological zones and this chapter has made quite a number of inferences from their work regarding GIS and remote sensing. There are significant shifts in agro-ecological zones based on datasets analyzed and projections for future in 2050. These shifts and changes can be picked at approximately 1 km and significantly identified as “zone shift.” Boitt et al. (2014) further concluded that multivariate clustering under a GIS environment is a very informative tool for agro-ecological zone definition. Global agro-ecological zone module V is the latest model for defining crop suitability for various regions. This module utilizes various climate datasets such as number of rainy days; mean minimum, mean maximum temperature; diurnal temperature range; cloudiness; wind speed and vapor pressure (IIASA/FAO 2012). Among this climate dataset, soil parameters are accommodated extensively (IIASA/FAO 2012). Its use among African countries is still limited and therefore needs to be scaled for adoption to the benefit of smallholder farmer levels. Its adoption is generally challenged by the limited use of GIS and remote sensing datasets in most African countries (Rowland et al. 2007). This module could provide the new insights into understanding climate variability and its impact on cropping seasons. Its use in evaluating existing information on agro-ecological zones of lower midland IV and V is paramount.

Wango et al. (2018) explore the suitability of WorldClim dataset in climate analysis and monitoring in the advent of climate change. All previous studies highlighted the role of GIS and remote in transforming the understanding of climate variability, thereby successfully addressing the climate change issues in Kenya and

Africa at large. For example, Henriksen (1986) emphasize the use of satellite remote sensing to capture and monitor the climate variability occurring year after year. Another research by Bartoszek et al. (2015), for Poland, affirms the use of satellite data as useful source of temporal and spatial variability of information on climate. FAO (2017) in the report on review of remote sensing tools, products, and methodologies points out, the issues that Africa is facing, when it comes to improved crop production forecasting. The reports highlights the improvement in technologies related to remote sensing and the mode of communication which are at varying levels of development. Further, the reports mention the problems of various institutions, especially the government, to integrate and use effectively remote sensing products. This in the end has affected timely crop forecasting across the continent. Finally, there are readily available good products of early warning system that Africa should take advantage of since they are free.

---

## Climate-Smart Crop Management

According to Mungai (2017), smallholder farmers in the East African region are facing unprecedented challenges in pursuit of increased production under increased climate change and variability. His work further gives highlights on the dire need for information on possible risk and viable management strategies. Information on risk stem from understanding the climate variability within the agro-ecological zones where farming is defined as discussed in previous sections of this chapter. Nsubuga and Rautenbach (2018) concluded that climate variability is bound to have considerable effects in terms of food availability, especially on the agriculture depended populations. They further point out that climatic variations and differences will continue to have a significant role in the geographic distribution of crop production. Understanding climate variations within agro-ecological zones and their influence on the soil environment is key in climate-smart crop management. The parameters selected in this chapter present time average maps that have shown increasing variations over years as result of climate change. Scaling down satellite imagery and remote sensing technologies for use by smallholder farmer presents one possible solution for the reduction of the impact of climate variability on food security. Previous studies have presented the challenges therein while highlighting various solutions that can be adopted. Nsubuga and Rautenbach (2018) in their reviews highlighted the importance of rainfall measurements in Uganda but failed to show a downward trend in rainfall amount yet there has been as shift precipitation rates as well as end and start of seasons. We looked at some of the climate-smart crop management practices that have been suggested and implemented. The chapter underpins the importance of climatic variability evaluation at agro-ecological zone level scaled down to farmers needs for successful climate-smart crop management. Food and Agriculture Organization (FAO) focus on climate-smart crop production pushes for crop production and practices that enable climate change and mitigation. In this view, different methods have been recommended and used. One of the approaches that has been advocated for is cropping systems which are believed to

cushion farmers against climate change shocks. The other is the use of quality seeds and plantings adapted to the various environments. Sustainability and the resilience of a production system is believed to be achieved through improved crop varieties suited for a wide range of agro-ecosystem FAO (2013).

Changes in temperature, precipitation, assessment of evapotranspiration characteristics and soil temperature-moisture regimes necessitate for new frontiers in the management of crops through introduction of adoptable technologies. Report by FAO (2013) on climate-smart crop production pushes for agricultural systems that are very efficient in terms of inputs while at the same having less variability. This will enable sustainability through the stability in the outputs hence more resilient in nature and therefore able to cushion against climate change shock and long-term variability. On the other hand, climate-smart intervention by smallholder farmers cannot be ignored (Ullah et al. 2019). Even though most of the local coping strategies and mechanism may be weak as earlier mentioned, they can be strengthened by incorporating them in technology-based smart inventions.

Another adaptation for climate-smart agriculture is through crop modeling that focuses on building early warning monitoring systems that effectively alter the overall management of the crop in volatile climate environment (Ullah et al. 2019). In his studies, he highlights the use of weather data smart interventions that involve close monitoring of climate variability and relaying of information to relevant stakeholders. This is bound to improve further if implemented under an environment of well evaluated and monitored agro-ecological zoning. This means, the cropping seasons and length of growing period variations within agro-ecological zones will be factored in. The advent of weather data smart intervention and yield forecasting through crop modeling place the use of satellite imagery in products provision in crucial place. Weather data smart intervention cannot forget platforms of forecasting more frequently to the farmers. Stigter (2010) gave focus on the importance of such advisory services in his studies. Zuma-Netshiukhwi et al. (2016) in his study emphasizes on the need for agro-meteorological knowledge transfer or extension services to end-users such as farmers and other relevant stakeholders. Further, he discusses the need for downscaling of seasonal climate to lower resolutions that can address the farmers' needs. Abura (2017) argues that there is need for meteorological department to streamline climate advisory services to the locals so that livelihoods risk as result of climate change can be reduced. This can be done by training of agricultural extension officer who in most developing countries work hand in hand with the smallholder farmers.

---

## Conclusion

This chapter concludes that variation within agro-ecological lower midland zones IV and V does exist and changes have been occurring over a long period of time. All the products from GIOVANNI NASA Earth data website have shown enormous variations. Secondly, earth observation products used alongside in situ information have the potential of improving agro-ecological zoning and the interpretation of the

cropping season and crop suitability. Thirdly, climate studies that have relayed conclusive information on agro-ecological zones have focused more on rainfall with exclusion of more datasets that can provide more insight in terms of understanding climatic trends and cropping systems.

Fourthly, use of more varied datasets that focus on varied precipitation parameters, varied temperatures parameters, evapotranspiration, thermal conditions of soil, and soil moistures content are likely to improve on the understanding of length of growing period, hence enabling the adoptions of crop varieties that are climate-smart for particular regions. The low adoption of earth observation products and technologies in remote sensing poses a problem in the monitoring of climate variability in Africa. Effective assessment of length of growing periods from climate information for Africa need to be strengthened and improved through adoption of earth observation products alongside in situ surveillance. Finally, the climate-smart crop management must be considered to cut across the various sectors and not agriculture alone if successful implementation is to be achieved. Agricultural systems can achieve climate-smart objectives through continuous monitoring of activities being undertaken at the agro-ecological zones level since they form very important platforms of crop productions in Kenya. This study confirms that climate-smart crop management under extreme weather in Kenya is unavoidable. This management will stem from the adoptions of technologies, strategies, and policies that focus on climate monitoring, evaluation of exiting agro-ecological zones, and adoption of agro-ecosystems that can support sustainable agriculture. In addition, future studies on climate change impact on marginal areas should consider focusing on further reclassification of agro-ecological zones in Kenya and evaluation of cropping season using both satellite imagery and in situ information to compensate for challenges and gaps experienced in previous studies. This will assist smallholders' farmers in addressing the current challenges that they have as a result of climate variability. Soil moisture assessment and integration and its inter-comparison to other parameters still remain a challenge that needs to be addressed.

---

## References

- Abura BA, Hayombe PO, Tonui WK (2017) Rainfall and temperature variations overtime (1986–2015) in Siaya county, Kenya. *Int J Educ Res* 5:11–20
- Aming P, Awange JL, Forootan E, Ogallo A, Girmaw B, Fesseha I, Kululetera V, Mbatii M, Kilavi M, King M, Adek P, Njogu A, Badr M, Musa A, Muchiri P (2014) Changes in temperature and precipitation extremes over the Greater Horn of Africa region from 1961 to 2010. *1277(June 2013): 1262–1277*. <https://doi.org/10.1002/joc.3763>
- Assiri ME (2017) Assessing MODIS land surface temperature (LST) over Jeddah. *Polish J Environ Stud* 26:1461–1470. <https://doi.org/10.15244/pjoes/68960>
- Ayugi BO, Tan G (2019) Recent trends of surface air temperatures over Kenya from 1971 to 2010. *Meteorol Atmos Phys* 131:1401–1413. <https://doi.org/10.1007/s00703-018-0644-z>
- Bartoszek K, Siłuch M, Bednarczyk P (2015) Characteristics of the onset of the growing season in Poland based on the application of remotely sensed data in the context of weather conditions and land cover types. *Eur J Remote Sens* 48:327–344

- De Beurs KM, Henebry GM (2010) Spatio-temporal statistical methods for modeling land surface phenology. In: Hudson IL, Keatley MR (eds) *Phenological research: methods for environmental and climate change analysis*. Springer, Dordrecht, pp 177–208
- Boitt MK, Mundia CN, Pellikka P (2014) Modelling the impacts of climate change on agro-ecological zones—a case study of Taita Hills, Kenya. *Univers J Geosci* 2:172–179. <https://doi.org/10.13189/ujg.2014.020602>
- Buckman HC, Brady NC (1971) *Soil and its properties* (in polish). PWRiL Press, Warsaw
- Camberlin P, Moron V, Okoola R et al (2009) Components of rainy seasons' variability in equatorial East Africa: onset, cessation, rainfall frequency and intensity. *Theor Appl Climatol* 98:237–249. <https://doi.org/10.1007/s00704-009-0113-1>
- Dai A (2010) Drought under global warming. *Interdiscip Rev Clim Change* 3(6):617–617. <https://doi.org/10.1002/wcc.81>
- Decker WL (1955) Determination of soil temperatures from meteorological data. *Retrospect Teses Dissert* 13252. <https://lib.dr.iastate.edu/rtd/13252>
- Donat MG, Alexander LV, Yang H et al (2013) Global land-based datasets for monitoring climatic extremes. *Bull Am Meteorol Soc* 94:997–1006. <https://doi.org/10.1175/BAMS-D-12-00109.1>
- Eitzinger A, Laderach P, Quiroga A, et al (2011) Future climate scenarios for Kenya's tea growing areas. pp 1–27
- Elbasit MA, Adam EO, Khalid Abu-Talib1, Ahmed F, Yasuda H, Ojha CSP (2014) Validation of satellite-based rainfall measurements in arid and semi-arid regions of sudan. *Proc 10th Int Conf AARSE*
- FAO (1978) *Agro-ecological zoning, guidelines*, Food and Agricultural Organization of the United Nations, Rome
- FAO (1996) *Agro-ecological zoning, guidelines*. Food and Agricultural Organization of the United Nations, Rome
- FAO (2002) Conservation agriculture – optimizing soil moisture for palnt production; the significance of soil porosity. In *FAO Soils Bulletin No. 79*. FAO, Rome. ISBN 92-5-104625 5. 69 p
- FAO (Food and Agriculture Organization) (2013) *Climate smart agriculture source book main report* E-ISBN 978-92-5-107721-4 (PDF). <https://www.fao.org/climatechange/climatesmart> Climate-Smart@fao.org
- FAO (Food and Agriculture Organization) (2017) *Review of the available Remote sensing tools, products, methodologies and data to improve crop production forecasts*, Rome 2017, <https://www.fao.org/publications>. ISBN 978-92-5-109840-0
- Fischer G, Shah M, Van H, Nachtergaele F (2006) *Agro-ecological zones assessment*
- Fischer G, Nachtergaele F, Prieler S, Velthuizen HT, van Verelst L, Wiberg D (2008) *Global Agro-ecological zones: model documentation*. Food Agri Organ UN
- Fiwa L, Vanuytrecht E, Wiyo KA, Raes D (2014) Effect of rainfall variability on the length of the crop growing period over the past three decades in central Malawi. *Clim Res* 62:45–58. <https://doi.org/10.3354/cr01263>
- Gatot IS, Duchesne J, Forest F, et al (2001) Rainfall-runoff harvesting for controlling erosion and sustaining upland agriculture development. pp 431–439
- Gregory PJ, Ingram JSI, Brklacich M (2005) Climate change and food security. *Philos Trans R Soc B Biol Sci* 360(1463):2139–2148. <https://doi.org/10.1098/rstb.2005.1745>
- Guo HD, Zhang L, Zhu LW (2015) Earth observation big data for climate change research. *Adv Clim Chang Res* 6:108–117. <https://doi.org/10.1016/j.accre.2015.09.007>
- Hastenrath S (2001) Variations of east African climate during the past two centuries. *Clim Chang* 50:209–217. <https://doi.org/10.1023/A:1010678111442>
- Hengl T, AghaKouchak A, Tadic MP (2010) Methods and data sources for spatial prediction of rainfall. In Testik FY, Gebremichael M (eds) *Rain-fall: state of the science*. American Geophysical Union (AGU), pp 186–214 New Age International Publisher.
- Henricksen BJ (1986) Determination of agro-ecological zones in Africa: ILCA activities and expectations. *ILCA Bull* 23:15–22



- Herrero M, Ringler C, Steeg J, Van De, Koo J, Notenbaert A (2010) Climate variability and climate change and their impacts on Kenya's agricultural sector. ILRI, Nairobi, Kenya 1–56. <https://doi.org/10.5539/jsd.v6n2p9>
- Holmes TRH, Owe M, De Jeu RAM, Kooi H (2008) Estimating the soil temperature profile from a single depth observation: a simple empirical heat flow solution. *Water Resour Res* 44:1–11. <https://doi.org/10.1029/2007WR005994>
- IIASA/FAO, 2012. Global agro-ecological zones (GAEZ v3.0). IIASA/FAO, Laxenburg/Rome
- Jiitold R, Kutsch H (2000) Agro-ecological zones of the tropics, with a sample from Kenya. April 1982
- Kamara SI, Jackson IJ (1997) A new soil-moisture based classification of raindays and dry days and its application to Sierra Leone. *Theor Appl Climatol* 56(3–4):199–213. <https://doi.org/10.1007/BF00866427>
- Kenawy AM, Hereher ME, Robaa SM (2019) An assessment of the accuracy of MODIS land surface temperature over Egypt using ground-based measurements. *Remote Sens* 11. <https://doi.org/10.3390/rs11202369>
- King'uyu SM, Ogallo LA, Anyamba EK (2000) Recent trends of minimum and maximum surface temperatures over eastern Africa. *J Clim* 13:2876–2886. [https://doi.org/10.1175/1520-0442\(2000\)013<2876:RTOMAM>2.0.CO;2](https://doi.org/10.1175/1520-0442(2000)013<2876:RTOMAM>2.0.CO;2)
- Kumar DK, Reshmidevi TV (2013) Remote sensing applications in water resources. *J Indian Inst Sci* 93(2):163–187
- Le Page Y, Vasconcelos M, Palminha A, Melo IQ, Pereira JMC (2017) An operational approach to high resolution agro-ecological zoning in West-Africa. *PLoS ONE* 12(9): e0183737. <https://doi.org/10.1371/journal.pone.0183737>
- Liou YA, Kar SK (2014) Evapotranspiration estimation with remote sensing and various surface energy balance algorithms-a review. *Energies* 7(5):2821–2849. <https://doi.org/10.3390/en7052821>
- Managua C (2011) Future climate scenarios for Uganda Tea growing areas. Managua, CIAT
- Marshall M, Funk C (2014) Examining evapotranspiration trends in Africa Examining evapotranspiration trends in Africa. <https://doi.org/10.1007/s00382-012-1299-y>
- McCulloch JSG (1965) Tables for the rapid computation of the Penman estimate of evaporation. *E Afr Agric J* 30:286
- Mendelsohn R (2008) The impact of climate change on agriculture in developing countries. *J Nat Resour Policy Res* 1:5–19. <https://doi.org/10.1080/19390450802495882>
- Meneghini R, Eckerman J, Atlas D (1983) Determination of rain rate from a spaceborne radar using measurements of total attenuation. *IEEE Trans Geosci Remote Sens* 1:34–43
- Mungai C (2017) Adoption and dissemination pathways for climate-smart agriculture technologies and practices for climate-resilient livelihoods in lushoto, Northeast Tanzania. *Climate* 5:63. <https://doi.org/10.3390/cli5030063>
- Mutiga JK, Su Z, Woldai T (2013) Corrigendum to “using satellite remote sensing to assess evapotranspiration: case study of the upper Ewaso Ng'iro North Basin, Kenya”. *Int J Appl Earth Obs Geoinf* 23(1):411. <https://doi.org/10.1016/j.jag.2012.10.011>
- Ndirangu S, Mbogoh S, Mbatia O (2017) Effects of land fragmentation on food security in three agro-ecological zones of embu county in Kenya. *Asian J Agri Ext Econ Soc* 18(4):1–9. <https://doi.org/10.9734/ajaees/2017/34321>
- Nsubuga FW, Rautenbach H (2018) Climate change and variability: a review of what is known and ought to be known for Uganda. *Int J Clim Chang Strateg Manag* 10(5):752–771. <https://doi.org/10.1108/IJCCSM-04-2017-0090>
- Nsubuga FWN, Botai OJ, Olwoch JM, Rautenbach CJd W, Bevis Y, Adetunji AO (2014) La nature des précipitations dans les principaux sous-bassins de l'Ouganda. *Hydrolog Sci J* 59(2):278–299. <https://doi.org/10.1080/02626667.2013.804188>
- Ochieng J, Kirimi L, Mathenge M (2015). Effects of climate variability and change on agricultural production: the case of small scale farmers in Kenya. *NJAS Wagen J Life Sci* 77:71–78. <https://doi.org/10.1016/j.njas.2016.03.005>. (2016)

- Omondi PA o, Awange JL, Forootan E et al (2014) Changes in temperature and precipitation extremes over the Greater Horn of Africa region from 1961 to 2010. *Int J Climatol* 34:1262–1277. <https://doi.org/10.1002/joc.3763>
- Osińska-Skotak K (2007) Studies of soil temperature on the basis of satellite data. *Int Agrophys* 21 (3):275–284
- Onwuka B (2018) Effects of soil temperature on some soil properties and plant growth. *Adv Plants Agric Res* 8:34–37. <https://doi.org/10.15406/apar.2018.08.00288>
- Parry M, Rosenzweig C, Iglesias A et al (1994) Climate change and world food security: a new assessment. *Glob Environ Chang* 9. [https://doi.org/10.1016/S0959-3780\(99\)00018-7](https://doi.org/10.1016/S0959-3780(99)00018-7)
- Pearce D (2000) Policy frameworks for the ancillary benefits of climate change. *Assess Ancillary Benefits Costs Greenh Gas Mitig* 517–560
- Pellarin T, Román-Cascón C, Baron C et al (2020) The precipitation inferred from soil moisture (PrISM) near real-time rainfall product: evaluation and comparison. *Remote Sens* 12:481. <https://doi.org/10.3390/rs12030481>
- Pinheiro ACT, Privette JL, Guillevic P (2006) Modeling the observed angular anisotropy of land surface temperature in a savanna. *IEEE Trans Geosci Remote Sens* 44:1036–1047
- Rowland J, Wood E, Tieszen LL, Lance K, Khamala E, Siwela B, Adoum A, Brown M (2007) Review of remote sensing needs and applications in Africa prepared by : contributors : development 1–124. <https://doi.org/10.13140/RG.2.1.1101.3849>
- Sabri NSA, Zakaria Z, Mohamad SE, Jaafar AB, Hara H (2018) Importance of soil temperature for the growth of temperate crops under a tropical climate and functional role of soil microbial diversity. *Microb Environ* 33(2):144–150. <https://doi.org/10.1264/jsm2.ME17181>
- Schneider U, Becker A, Ziese M, Rudolf B (2018) Global precipitation analysis products of the GPCP. *Glob Precipitation Climatology Cent* 1–14
- Schollaert Uz S, Ruane AC, Duncan BN et al (2019) Earth observations and integrative models in support of food and water security. *Remote Sens Earth Syst Sci* 2:18–38. <https://doi.org/10.1007/s41976-019-0008-6>
- Schreck CJ, Semazzi FHM (2004) Variability of the recent climate of eastern Africa. *Int J Climatol* 24(6):681–701. <https://doi.org/10.1002/joc.1019>
- Seo SN, Mendelsohn R, Dinar A et al (2009) A Ricardian analysis of the distribution of climate change impacts on agriculture across agro-ecological zones in Africa. *Environ Resour Econ* 43:313–332. <https://doi.org/10.1007/s10640-009-9270-z>
- Skawina T, Kossowski J, Stępniewski W, Walczak R (1999) Physical properties of soils (in polish). In: Zawadzki S (ed) *Soil science*. PWRiL Press, Warsaw
- Skolnik MI (1962) Introduction to radar. *Radar Handbook*, 2
- Slatyer RO, Mabbutt JA (1964) Hydrology of arid and semiarid regions. Section 24 V.T
- Stigter K, Walker S, Das HP, Huda S, Dawei Z, Jing L, Chunqiang L, Hurtado IHD, Mohammed AE, Abdalla AT, Bakheit NI, Al-Amin NKN, Yurong W, Kinama JM, Nanja D, Haasbroek PD (2010) Meeting farmers' needs for agrometeorological services: an overview and case studies
- Sun Y (2009) Retrieval and application of land surface temperature. *Geo-UtexasEdu* 1:1–27
- Thies B, Nauß T, Bendix J (2008) Precipitation process and rainfall intensity differentiation using meteosat second generation spinning enhanced visible and infrared imager data. *J Geophys Res Atmos* 113:1–19. <https://doi.org/10.1029/2008JD010464>
- Ullah W, Wang G, Ali G et al (2019) Comparing multiple precipitation products against in-situ observations over different climate regions of Pakistan. *Remote Sens* 11:628. <https://doi.org/10.3390/rs11060628>
- Vlassova L, Perez-Cabello F, Nieto H et al (2014) Assessment of methods for land surface temperature retrieval from landsat-5 TM images applicable to multi-scale tree-grass ecosystem modeling. *Remote Sens* 6:4345–4368. <https://doi.org/10.3390/rs6054345>
- Vrieling A, De Leeuw J, Said MY (2013) Length of growing period over Africa: variability and trends from 30 years of NDVI time series. *Remote Sens* 5:982–1000. <https://doi.org/10.3390/rs5020982>
- Wango TJJ, Musiega D, Mundia CN (2018) Assessing the suitability of the worldclim dataset for ecological studies in Southern Kenya. *J Geogr Inform Syst* 10(06):643–658. <https://doi.org/10.4236/jgis.2018.106033>

- White MA, de Beurs KM, Didan K, Inouye DW, Richardson AD, Jensen OP, O’Keefe J, Zhang G, Nemani RR, van Leeuwen WJD et al (2009) Intercomparison, interpretation, and assessment of spring phenology in North America estimated from remote sensing for 1982–2006. *Glob Chang Biol* 15:2335–2359
- Zuma-Netshiukhwi GN, Stigter KC, Walker S (2016) Improving agricultural decision making using weather and climate information for farmers, south-western Free State, South Africa. *Net J Agric Sci* 4:67–77

**Open Access** This chapter is licensed under the terms of the Creative Commons Attribution 4.0 International License (<http://creativecommons.org/licenses/by/4.0/>), which permits use, sharing, adaptation, distribution and reproduction in any medium or format, as long as you give appropriate credit to the original author(s) and the source, provide a link to the Creative Commons license and indicate if changes were made.

The images or other third party material in this chapter are included in the chapter’s Creative Commons license, unless indicated otherwise in a credit line to the material. If material is not included in the chapter’s Creative Commons license and your intended use is not permitted by statutory regulation or exceeds the permitted use, you will need to obtain permission directly from the copyright holder.





# Water Resource Management Frameworks in Water-Related Adaptation to Climate Change

# 50

Godfrey Odongtoo, Denis Ssebuggwawo, and Peter Okidi Lating

## Contents

Introduction .....	994
Background .....	994
Analytical Framework .....	996
Adaptation and ICT Frameworks .....	996
Objective .....	997
Methods .....	997
Study Hypotheses .....	997
Data Collection .....	998
Data Analysis .....	998
Results and Discussion .....	999
Respondents' Profile .....	999
Demographic Information of the Respondents .....	1000
Evaluation of Outer Measurement Model .....	1000

---

This chapter was previously published non-open access with exclusive rights reserved by the Publisher. It has been changed retrospectively to open access under a CC BY 4.0 license and the copyright holder is "The Author(s)". For further details, please see the license information at the end of the chapter.

---

G. Odongtoo (✉)

Department of Computer Engineering, Busitema University, Tororo, Uganda

Department of Information Technology, Makerere University, Kampala, Uganda

D. Ssebuggwawo

Department of Computer Science, Kyambogo University, Kampala, Uganda

e-mail: [dssebuggwawo@kyu.ac.ug](mailto:dssebuggwawo@kyu.ac.ug)

P. O. Lating

Department of Electrical and Computer Engineering, Makerere University, Kampala, Uganda

e-mail: [plating@cedat.mak.ac.ug](mailto:plating@cedat.mak.ac.ug)

© The Author(s) 2021

W. Leal Filho et al. (eds.), *African Handbook of Climate Change Adaptation*,

[https://doi.org/10.1007/978-3-030-45106-6\\_24](https://doi.org/10.1007/978-3-030-45106-6_24)

993

Business Benefit .....	1003
Conclusion, Recommendation, and Future Research .....	1003
Conclusion .....	1003
Recommendation .....	1004
Lesson Learned and Future Studies .....	1004
Future Studies .....	1004
References .....	1004

## Abstract

This chapter addresses the use of partial least squares–structural equation modeling (PLS-SEM) to determine the requirements for an effective development of water resource management frameworks. The authors developed a quantitative approach using Smart-PLS version 3 to reveal the views of different experts based on their experiences in water-related adaptation to climate change in the Lake Victoria Basin (LVB) in Uganda. A sample size of 152 was computed from a population size of 245 across the districts of Buikwe, Jinja, Mukono, Kampala, and Wakiso. The chapter aimed to determine the relationship among the availability of legal, regulatory, and administrative frameworks, public water investment, price and demand management, information requirements, coordination structures, and analytical frameworks and how they influence the development of water resource management frameworks. The findings revealed that the availability of legal, regulatory, and administrative frameworks, public water investment, price and demand management, information requirements, and coordination structures had significant and positive effects on the development of water resource management frameworks. Public water investment had the highest path coefficient ( $\beta = 0.387$  and  $p = 0.000$ ), thus indicating that it has the greatest influence on the development of water resource management frameworks. The  $R^2$  value of the model was 0.714, which means that the five exogenous latent constructs collectively explained 71.4% of the variance in the development. The chapter suggests putting special emphasis on public water investment to achieve an effective development of water resource management frameworks. These findings can support the practitioners and decision makers engaged in water-related adaptation to climate change within the LVB and beyond.

## Keywords

Climate change · Lake Victoria Basin · PLS-SEM · Water resource management frameworks

## Introduction

### Background

There is an increasing pressure on water resources in the Lake Victoria Basin (LVB) due to rapid population growth, increased urbanization and industrialization, uncontrolled environmental degradation, and pollution (Dauglas et al. 2014;

Bakibinga-ibembe et al. 2011). These pressures still remain as a big challenge to the sustainable management of water resources (Mongi et al. 2015). Moreover, the LVB remains to be an important water resource for five countries, namely, Uganda, Kenya, Tanzania, Rwanda, and Burundi. The LVB is the largest freshwater lake in Africa with a surface area of 68,800 km<sup>2</sup>. It provides resources for fishing, agriculture, medicine, forestry, water transport, and other economic activities (Odongtoo et al. 2018). Its surrounding area is affected by increasing commercial activities and inadequate provision of sanitation services, among others (Okurut 2010; Wafula et al. 2014). These affect the landscape and water resources around the lake, making the water unsuitable for use.

According to Oyoo-Okoth et al. (2010), there is a combination of four analyzed heavy metals in the water samples of the LVB showing similar presence of heavy metal in the waters within the lake. This can be attributed to the fact that human activities, such as industrialization and agricultural practices, seriously contribute to the degradation and pollution of the environment, which adversely affect the water bodies, as noted by Devi et al. (2018). Increased human activities, such as poor land use, uncontrolled abstractions, and water pollution, greatly reduce the quantity and quality of the available water resources.

Globally, water resources are facing severe degradation due to pollution and inefficient water resource management strategies (Wang et al. 2015). It has been reported that water pollution causes approximately 14,000 deaths per day, mostly due to drinking water contamination caused by untreated sewage in developing countries (Devi et al. 2018). Rinawati et al. (2013) argued that these challenges create potential major threats to global biodiversity around water bodies, such as the LVB. The above authors further observed that this is true of the biodiversity around LVB as noted by Case (2006). The most recent statistics show that cities and small towns within the LVB are rapidly growing (Dauglas et al. 2014). The best examples of the growth pattern of towns and cities can be observed in Mwanza in Tanzania, Jinja and Port Bell in Uganda, and Kisumu in Kenya. Both population growth and urbanization have negative impacts on the quality and quantity of water resources. Some of these impacts include eutrophication and siltation, in addition to water pollution, as a result of increased runoff from bare lands as deforestation persists around the LVB (Ondieki 2015). Muhweezi (2014) also noted that biodiversity and ecosystem-specific goods and services around the LVB are likely to be adversely affected in the future by water pollution. It can be inferred that these challenges revolve around poor management of water resources. Failure to address such challenges will cause serious problem to the lives of many people who depend on the LVB.

Poor management of the scarce water resources can lead to climate change. The climate is continuously changing and is getting worse over time. Moreover, extreme weather conditions are occurring more frequently than before, thus negatively affecting the agricultural sector, consequently leading to food shortages. Farmers from different age groups acknowledge an increase in temperature, and they agree that the temperature is increasing with time (Mongi et al. 2015).

According to Leal et al. (2015), water is one of the essential resources for human being, and its availability has great impacts on the environmental, political, and economic situations. This means that water resources have to be managed well. Water resource management is the activity of planning, developing, distributing, and managing the optimum use of water resources (Okurut 2010). Ssozi et al. (2015) defined water resource management as the development of political, social, economic, and administrative systems to develop and manage water resources. According to the technical committee of the Global Water Partnership, Integrated Water Resources Management (IWRM) is a process that promotes the coordinated development and management of water, soil, and other related resources to maximize the resultant economic and social welfare in an equitable manner without compromising the sustainability of vital ecosystem (ITU-T 2010).

## Analytical Framework

Water resource management has been recently developed due to the improvement in water technology, natural events, economic developments, and changing social needs. The current trend in water management changed from technical to a combination of technical and sociopolitical perspectives (Demetropoulou et al. 2010). This led to an increase in stakeholders and public participation. It is therefore necessary to establish a framework to guide practitioners and managers in water resource management. For managers and decision makers to conduct good analysis, it is necessary to use analytical frameworks to promote logical thinking in a systematic manner.

## Adaptation and ICT Frameworks

According to Akoh et al. (2011), the frameworks of Information and Communication Technology (ICTs) in mitigating climate change and adaptation are still relatively new. Frameworks on adaptation to climate change can be considered in three ways: first, to emphasize the potential of ICTs to reduce vulnerability to climate change by building resilience; second, to focus on delivering different types of information needed to achieve effective climate change adaptation; and third, to emphasize a disaster risk management framework focusing on the reduction of community vulnerabilities and management and recovery from emergencies as they arise.

According to the 1992 Dublin Conference on water and the Rio de Janeiro Summit on sustainable development (White 2013), the four key principles adopted were as follows: first, freshwater is a finite and vulnerable resource essential to life, development of irrigation, industrial and transport sector, and the environment; second, water development and management should be based on a participatory approach, involving users, planners, and policy makers at all levels; three, women play a central part in the provision, management, and safeguarding of water; and

fourth, water has an economic value in all its competing uses and should be recognized as an economic good.

---

## **Objective**

The objective of this chapter was to apply a PLS-SEM to evaluate the requirements for the development of water resource management framework in water-related adaptation to climate change in Uganda's side of the LVB.

---

## **Methods**

In evaluating the requirements for the development of water resource management framework in water-related adaptation to climate change, PLS-SEM was used. The proposed model was analyzed in two different stages: first, the model was composed of measurement models that define the relationship between latent indicators and their manifest variables, and second, a structural model showing the relationship between the manifest variables. A total of 24 factors which were obtained from the literature review were named as the observed variables and were divided into six groups: availability of legal, regulatory, and administrative frameworks, analytical framework, public water investment, information requirements, coordination structures, and pricing and demand management. These six groups were called exogenous latent constructs. Thus, an effective water resource management framework is influenced by the six major constructs.

## **Study Hypotheses**

Based on the objectives of the research, the hypothesized model was developed. Quantitative data to test the hypothesis was collected from experts in water resource sectors and was subjected to Smart-PLS test. Some of the hypotheses passed the test and were therefore accepted, whereas the others that failed the test were rejected. Hypothesis 1 (H1): Availability of legal, regulatory, and administrative frameworks has a significant and positive effect on the development of water resource management frameworks. Hypothesis 2 (H2): Analytical framework has a significant and positive effect on the development of water resource management frameworks. Hypothesis 3 (H3): Public water investment has a significant and positive effect on the development of water resource management frameworks. Hypothesis 4 (H4): Information requirements has a significant and positive effect on the development of water resource management frameworks. Hypothesis 5 (H5): Coordination structures has a significant and positive effect on the development of water resource management frameworks. Hypothesis 6 (H6): Pricing and demand management has a significant and positive effect on the



development of water resource management frameworks. This hypothesis design was adapted from Shahid et al. (2018).

## Data Collection

The data collection procedures involved three important phases. In the first phase, preliminary variables were obtained to formulate hypotheses using the materials in the review of literature, such as books, journals, and conference materials. In phase two, a pilot study was conducted to ensure consistency and completeness to help modify the questionnaire. Lastly, the questionnaire survey was conducted to obtain the opinion of the respondents. This study procedure was adapted from Shahid et al. (2018). Data collection was performed in the Buikwe, Jinja, Mukono, Kampala, and Wakiso districts in Uganda. The above districts were chosen based on the fact that those areas heavily depend on the LVB and at the same time were immensely affected by the decline in water resources. The key stakeholders that were engaged in this chapter included employees from the LVB Commission, the LV Fishery Organization, District Environmental Officers, District Forestry Officers, NEMA, Ministry of Water and Environment, National and Regional Policymaking and Communication Organs, and key community leaders. To calculate the sample size, Slovin's formula was used,  $n = \frac{N}{1 + Ne^2}$ , where  $n$  denotes the sample size,  $N$  denotes the population size, and  $e$  denotes the error margin. The population size of 245 was used with a confidence interval of 95% and error margin of 5%, generating a sample size of 152.

The questionnaire was composed of two sections. Section one consisted of the respondents' personal information. Section two consisted of variables appropriately grouped into six categories based on the nature of the measurements/constructs: availability of legal, regulatory, and administrative frameworks (LRA), analytical frameworks (AF), public water investment (PW), information requirements (IR), coordination structures (CS), and pricing and demand management. The questionnaires were administered to different stakeholders with an experience of more than 5 years in the water resource sector, such as executives, managers, water engineers, and IT officers. During the 4 months of study, valuable opinions from experts were obtained and incorporated in the model.

## Data Analysis

The hypothesized structural model was analyzed using Smart-PLS version 3. Smart-PLS has advantages over other regression-based methods: First, it is capable of evaluating several latent constructs with various manifest variables and is considered as the best technique for multivariate analysis (Shahid et al. 2018). Second, it is suitable for evaluating the constructs when the sample size is less than 200 in comparison with other SEM software, such as AMOS, which require a sample size of more than 200. In this specific chapter, the sample size was 152 and therefore

justifies the use of Smart-PLS. Smart-PLS involves a two-step procedure, namely, evaluation of the outer measurement model and evaluation of the inner structural model (Henseler et al. 2009).

## Results and Discussion

### Respondents' Profile

Table 1 shows the demographic information of the respondents. The respondents were selected from a wide range of professionals engaged in the water resource sector. About 61.8% of the interviewed experts were male. Majority of the interviewed individuals were in the middle age group (30–39 years) (34.9%), followed by the young age group (20–29 years) (31.6%), (40–49) years were 23.7%. Those aged 50 years and above only accounted for 9.9% of the total population. This research is part of a bigger study conducted to develop a water resource management ICT model in the LVB.

**Table 1** Demographic information

Response item	Count	Percent
<b>Gender Distribution</b>		
Female	58	38.2
Male	94	61.8
Total	152	100.0
<b>Age Group</b>		
20–29 years	48	31.6
30–39 years	53	34.9
40–49 years	36	23.7
50–59 years	14	9.2
Above 59 years	1	0.7
Total	152	100.0
<b>Qualification</b>		
PhD	4	2.6
Masters	68	44.7
Bachelors	67	44.1
Diploma	13	8.6
Total	152	100.0
<b>Designation</b>		
Manager/Administrator	33	21.7
Staff/Employee	100	65.8
Systems Administrator	8	5.3
Client/Customer	1	0.7
Total	152	100.0

## Demographic Information of the Respondents

In Table 1, the highest percentage (44.7%) of the respondents have acquired master's degree, followed by bachelor's degree (44.1%), diploma (8.6%), and PhD (2.6%). The highest category of workers (65.8%) was staff/employee, followed by managers/administrators (21.7%), system administrators (5.3%), and ICT technicians (6.6%).

The level of education, the designation, the age, and the sex have significant effects on the perception of a person with regard to information. Older people tend to have more experiences, whereas highly educated ones display more in-depth knowledge on the subject matter of research. A low level of education has an impact on the use and adoption of technologies. The designation status is related more to the skills in the management of water resources. This promoted trust on the outcome of this study.

## Evaluation of Outer Measurement Model

### Outer Loading

In order to determine whether what was hypothesized was in line with the collected data, PLS-SEM was employed. PLS-SEM is very suitable for theory building and for examining the complex relationship of the models. The outer measurement model was used to calculate the reliability, internal consistency, and validity of the observed variables together with the unobserved variables (Gabriel et al. 2016). Consistency evaluations were based on a single observed and construct reliability tests, whereas convergent validity and discriminant validity were used for validity assessment. The observed variables with an outer loading of at least 0.7 are acceptable and should therefore be retained, whereas those with values less than 0.7 should be dropped (Shahid et al. 2018; Smith et al. 2014). From Table 2, the outer loadings of the retained variables ranged between 0.819 and 0.917 which are more than 0.7 and

**Table 2** Construct reliability and validity

Main constructs	Item	Outer loading	T-statistics	CR	AVE
Availability of legal, regulatory, and administrative Frameworks	LRA2	0.799	12.766	0.812	0.683
	LR3	0.853	16.156		
Coordination structures	CS2	0.773	10.034	0.839	0.724
	CS4	0.922	40.008		
Information requirements	IR1	0.890	34.942	0.886	0.796
	IR2	43.681	43.681		
Public water investments	PW11	13.500	13.5	0.742	0.591
	PW13	9.463	9.463		
Price and demand managements	PDM2	14.359	14.359	0.810	0.681
	PDM3	19.859	19.859		

therefore valid. The variables, namely, collection and allocation, reuse of waste water, and water resource management, were dropped since their outer loading were below 0.7. Composite reliability (CR) was used for internal consistency evaluation in the construct reliability.

### Average Variance (AVE)

To establish convergent validity on the construct, average variance extracted (AVE) is normally used. It is the grand mean value of the squared loadings of the indicators associated with the construct and is the sum of the squared loadings divided by the number of indicators. An AVE value of at least 0.50 shows that the construct explains more than half of the variance of its indicators (Hair et al. 2011). As shown in Table 2, the AVE values are greater than 0.5; therefore, both their convergent validity and internal validity are acceptable for this measurement model. In Table 3, the cross-loading of all observed variables are greater than the inter-correlations of other constructs in the model. The Fornell–Larcker criterion is a very good approach for assessing discriminant validity. It compares the square root of the AVE values with the latent variable correlations. The square root of each construct’s AVE should be greater than its highest correlation with any other construct (Shahid et al. 2018). Therefore, these findings confirmed the cross-loading assessment standards which provided acceptable validation for the discriminant validity of the measurement model.

Using the t-test approach, some of the items that measure each construct were either retained or dropped, depending on whether the t-values are more or less than 2.76. The t-values must be greater than 2.76 for it to be retained as a measure for the variable (Hair et al. 2013; Shadfar and Malekmohammadi 2013). In Table 2, all the t-values of the retained items in measuring each construct are greater than 2.76.

**Table 3** Discriminant validity for water resource management frameworks

	<i>LRA</i>	<i>CS</i>	<i>IR</i>	<i>PDM</i>	<i>PDM</i>
Availability of legal, regulatory, and administrative frameworks (LRA)	0.827				
Coordination structures (CS)	0.615	0.851			
Information requirements(IR)	0.092	0.135	0.892		
Price and demand management (PDM)	0.532	0.575	0.072	0.825	
Public water investment (PWI)	0.029	0.067	0.308	0.054	0.769

**Table 4** Path coefficient

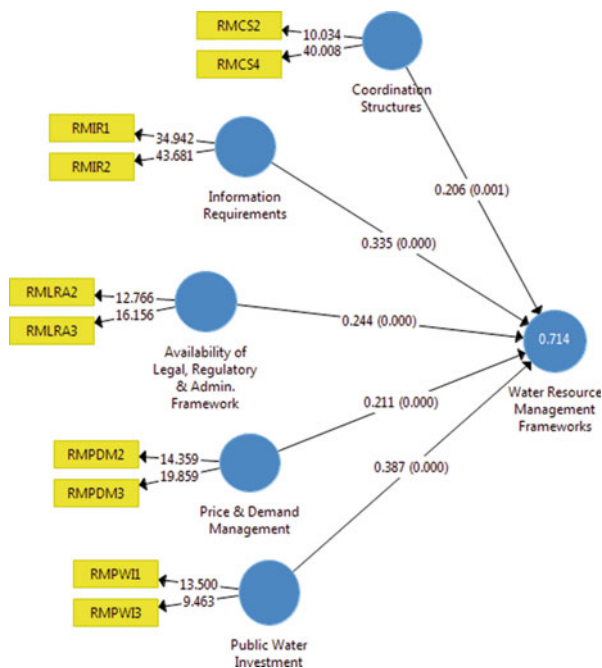
Hypothesized path	Standardized $\beta$	P-values
Availability of legal, regulatory, and administrative frameworks	0.244	0.000
Coordination structures (CS)	0.206	0.001
Information requirements(IR)	0.335	0.000
Price and demand management (PDM)	0.211	0.000
Public water investment (PWI)	0.387	0.000

### Estimation of Path Coefficients (b) and P-values

The significance of the hypotheses was tested by calculating the *beta* ( $\beta$ ) values. The  $\beta$  values indicate the measure of the effect the variable has on the model. The higher the values, the stronger the effect, and it is always  $< 1$ . As shown in Table 4, both the  $\beta$  and  $p$  values of every path in the hypothesized model were calculated.

In (H1), researchers hypothesized that availability of legal, regulatory, and administrative frameworks would significantly and positively influence the development of water resource management frameworks. The findings in Table 4 and Fig. 1 confirm that Availability of Legal, Regulatory, and Administrative Frameworks of water-related factor significantly influenced the development of water resource management frameworks ( $\beta = 0.244, p < 0.000$ ). Hence, H1 was excellently confirmed. Furthermore, the findings from Table 4 and Fig. 1 hypothesized that the (H3) public water investment-related factor positively influenced the development of water resource management frameworks ( $\beta = 0.387, p < 0.000$ ), showing that (H3) was effectively approved. Information requirements (IR) significantly and positively influenced the development of water resource management frameworks ( $\beta = 0.335, p < 0.000$ ). Coordination structure (CS)-related factor was positive and significant ( $\beta = 0.206, p < 0.001$ ), thus greatly supporting. The effect of price and demand management-related factor ( $\beta = 0.211, p < 0.000$ ) was also confirmed, thereby supporting (H6). The greater the  $\beta$  coefficient, the stronger the effect of an exogenous latent construct on the endogenous latent construct. Analytical frameworks were dropped from the list because they failed both the t-test and the outer loading test.

**Fig. 1** The graphical representation of all path coefficients of the water resource management frameworks



The  $R^2$  value of the model was 0.714, which means that the five exogenous latent constructs collectively explained 71.4% of the variance in the development of water resource management frameworks. The study suggests putting special emphasis on the public water investment factor to achieve an effective development of water resource management frameworks. These findings can support the practitioners and decision makers engaged in water-related adaptation to climate change within the LVB and beyond.

### **Limitation of the Study**

The limitation and constraint of the chapter came from the fact that it was not possible to visit all the countries of the East African Community due to logistical constraints. This will be part of the future works when the current logistical constraints are solved.

---

### **Business Benefit**

In accordance with the complete analysis of the measurement models and structural model, some of the hypotheses were statistically significant and hence were accepted, whereas the others failed the analysis. The results of this chapter support a richer and accurate picture of the factors influencing the development of effective water resource management frameworks. It is therefore important to consider the availability of legal, regulatory, and administrative frameworks, coordination structures, information requirements, price and demand management, and public water investment factors in the development of effective water resource management frameworks. The information obtained from this chapter will also enrich the body of knowledge that will benefit other researchers in the field of water resource management.

---

### **Conclusion, Recommendation, and Future Research**

#### **Conclusion**

The key contribution of this chapter was the empirical identification of the constructs that can influence the development of effective water resource management frameworks and also the investigation of the fundamental issues affecting the constructs observed by water experts in the LVB. The results of the chapter revealed that availability of legal, regulatory, and administrative frameworks, coordination structures, information requirements, price and demand management, and public water investment had significant positive effects on the development of water resource management frameworks. This therefore suggests that emphasis should be put on the above variables. The final results of the partial least squares–structural equation modeling revealed that public water investment had the highest path coefficient ( $\beta = 0.387$ ), thus indicating a major influence on the water resource management

frameworks. Therefore, water resource managers should pay more attention to public water investment factors during the development of water resource management frameworks.

## Recommendation

This chapter recommends that for a successful development of water resource management frameworks, emphasis should be put on availability of legal, regulatory, and administrative frameworks, coordination structures, information requirements, price and demand management, and public water investment. Since public water investment had the highest path coefficient ( $\beta = 0.387$ ) with a major overall influence on the development of water resource management frameworks, more emphasis should be put on it.

## Lesson Learned and Future Studies

This chapter revealed that majority of the people engaged in different activities around the LVB are unaware of the dangers posed by their economic activities. Moreover, the local leaders lack effective and efficient means of disseminating and sharing information on the LVB and the impact of human activities on ecosystems, biodiversity, and water resources.

## Future Studies

The areas for further research may focus on the study of how effective water resource management frameworks influence the design of an effective water resource management ICT model for an integrated water resource management of the LVB .

---

## References

- Akoh B, Livia B, Perry J-E, Creech H, Karami J, Echeverria D, ... Gass P (2011) Africa transformation-ready: the strategic application of information and communication technologies to climate change adaptation in Africa. Prepared for the African Development Bank, the World Bank and the African Union, Bristol
- Bakibinga-ibembe DJ, Said AV, Mungai WN (2011) Environmental laws and policies related to periodic flooding and sedimentation in the Lake Victoria Basin of East Africa. *Afr J Environ Sci Technol* 5(5):367–380
- Case (2006) Climate change impacts on East Africa. A review of the scientific literature. WWF-World Wide Fund for Nature (formerly World Wildlife Fund), Gland

- Dauglas WJ, Hongtao W, Fengting L (2014) Impacts of population growth and economic development on water quality of a lake: case study of Lake Victoria Kenya water. *Environ Sci Pollut Res* 21:5737–5746. <https://doi.org/10.1007/s11356-014-2524-5>
- Demetropoulou L, Nikolaos N, Papadoulakis V, Tsakiris K, Koussouris T, Kalogerakis N, Koukaras K (2010) Water framework directive implementation in Greece: introducing participation in water governance – the case of the Evrotas River Basin Management Plan. *Environ Policy Gov* 20:336–349
- Devi SP, Jothi S, Devi A (2018) Data mining case study for water quality prediction using R tool. *Int J Sci Res Comput Sci Eng Inform Technol* 3(1):262–269
- Gabriel C, Christian MR, Jörg H, José L (2016) Prediction-oriented modeling in business research by means of PLS path-modeling. *J Bus Res* 69(10):4545–4551
- Hair JF, Ringle C, Sarstedt M (2011) PLS-SEM: indeed a silver bullet. *Market Theory Pract* 19:139–151
- Hair FJ, Ringle MC, Sarstedt M (2013) Partial least square structural equation modelling: rigorous application, better results and higher acceptance. *Long Range Plan* 46:1–12
- Henseler J, Ringle C, Sinkovics R (2009) The use of partial least squares path modeling in international marketing. *Adv Int Market* 20:277–319
- Leal FW, Trinchera DJ, Vogt J (2015) Towards sustainable water use: experiences from the projects AFRHINET and Baltic flows. In: Leal Filho W, Sümer V (eds) *Sustainable water use and management, green energy and technology*. Springer, Cham
- Mauree V (2010) ICT as an enabler for smart water management. ITU-T Technology Watch Report, ITU Telecommunication Standardization Bureau, p 23
- Mongi HJ, Mvuma AN, Kucel S, Tenge AJ, Gabriel M (2015) Accessibility and utilization of mobile phones for governance of water resources in the Lake Victoria Basin: constraints and opportunities in Tanzania. *Afr J Environ Sci Technol* 9(5):438–450
- Muhweezi AB (2014) An overview of climate change and biodiversity in Uganda. African and Latin American Resilience to Climate Change Project. <https://doi.org/AID-OAA-TO-11-00064>
- Odongtoo G, Ssebugwawo D, Okidi LP (2018) Factors affecting communication and information sharing for water resource management in Lake Victoria. In: *Handbook of climate change and biodiversity*. Springer, Cham, pp 211–222
- Okurut T (2010) Integrated environmental protection approaches: strengthening the role of water supply operators in resource conservation. In: 15th international African water congress and exhibition commonwealth resort, Munyonyo, Kampala, Uganda
- Ondieki MC (2015) Aspects of water quality and water pollution control in vulnerable environments. *J Geogr Earth Sci* 3(2):83–93
- Oyoo-Okoth E, Wim A, Osano O, Kraak MHS, Ngure V, Makwali J, Orina PS (2010) Use of the fish endoparasite *ligula intestinalis* (L., 1758) in an intermediate cyprinid host (*Rastreneobola argentea*) for biomonitoring heavy metal contamination in Lake Victoria, Kenya. *Lakes Reserv Res Manag* 15:63–73
- Rinawati F, Stein K, Lindner A (2013) Climate change impacts on biodiversity – the setting of a lingering global crisis. *Biodiversity* 5:114–112
- Shadfar S, Malekmohammadi I (2013) Application of structural equation modeling (SEM) in restructuring state intervention strategies toward paddy production development. *Int J Acad Res Bus Soc Sci* 3(12):576
- Shahid H, Fangwei Z, Ahmed FS, Ali Z, Muhammad SS (2018) Structural equation model for evaluating factors affecting quality of social infrastructure projects. *Open Access J Sustain* 10:1415
- Smith RG, Davis AS, Jordan NR, Atwood LW, Daly AB, Grandy AS, . . . Yannarell AC (2014) Structural equation modeling facilitates transdisciplinary research on agriculture and climate change. *Crop Sci* 54:475–483



- Ssozi F, Blake E, Rivett U (2015) Designing for sustainability: involving communities in developing ICT interventions to support water resource management. <https://doi.org/978-1-905824-51-9>
- Wafula JD, Wang H, Li F (2014) Impacts of population growth and economic development on water quality of a lake: case study of Lake Victoria Kenya water (Garrigues P, ed). Springer, Berlin/Heidelberg
- Wang Z, Song H, Watkins DW, Ong KG, Xue P, Yang Q, Shi X (2015) Cyber-physical systems for water sustainability: challenges and opportunities. *IEEE Commun Mag* 53(5):216–222
- White C (2013) Integrated water resources management: what is it and why is it used? Retrieved from <https://globalwaterforum.org/2013/06/10/integrated-water-resources-management-what-is-it-and-why-is-it>

**Open Access** This chapter is licensed under the terms of the Creative Commons Attribution 4.0 International License (<http://creativecommons.org/licenses/by/4.0/>), which permits use, sharing, adaptation, distribution and reproduction in any medium or format, as long as you give appropriate credit to the original author(s) and the source, provide a link to the Creative Commons license and indicate if changes were made.

The images or other third party material in this chapter are included in the chapter's Creative Commons license, unless indicated otherwise in a credit line to the material. If material is not included in the chapter's Creative Commons license and your intended use is not permitted by statutory regulation or exceeds the permitted use, you will need to obtain permission directly from the copyright holder.





# Retracing Economic Impact of Climate Change Disasters in Africa: Case Study of Drought Episodes and Adaptation in Kenya

# 51

Mary Nthambi and Uche Dickson Ijioma

## Contents

Introduction .....	1008
Climate Change Adaptation Measures in the Agriculture Sector of Sub-Saharan Africa ....	1010
Methodology .....	1011
Study Area .....	1011
Methods .....	1014
Results and Discussion .....	1015
Drought Identification and Historical Trend Analysis .....	1015
Evaluation of Economic Impacts of Drought on the Agriculture Sector in Kenya .....	1018
Statistical Analysis of Drought Impact on Selected Economic Indicators .....	1022
Identified Climate Change Adaptation Measures in Makueni County .....	1024
Conclusions .....	1027
References .....	1028

## Abstract

Valuation studies have shown that drought occurrences have more severe economic impact compared to other natural disasters such as floods. In Kenya, drought has presented complex negative effects on farming communities. The main objective of this chapter is to analyze the economic impacts of drought and

This chapter was previously published non-open access with exclusive rights reserved by the Publisher. It has been changed retrospectively to open access under a CC BY 4.0 license and the copyright holder is “The Author(s)”. For further details, please see the license information at the end of the chapter.

M. Nthambi (✉)

Department of Environmental Economics, Brandenburg University of Technology Cottbus-Senftenberg, Cottbus, Germany

U. D. Ijioma

Department of Raw Material and Natural Resource Management, Brandenburg University of Technology Cottbus-Senftenberg, Cottbus, Germany

e-mail: [ijiomuch@b-tu.de](mailto:ijiomuch@b-tu.de); [u.d\\_ijioma@yahoo.com](mailto:u.d_ijioma@yahoo.com)

© The Author(s) 2021

W. Leal Filho et al. (eds.), *African Handbook of Climate Change Adaptation*,  
[https://doi.org/10.1007/978-3-030-45106-6\\_66](https://doi.org/10.1007/978-3-030-45106-6_66)

1007

identify appropriate climate change adaptation measures in Kenya. To achieve this objective, an empirical approach, combined with secondary data mined from World Bank Climate Knowledge Portal and FAOSTAT databases, has been used in three main steps. First, historical links between population size and land degradation, temperature and rainfall changes with drought events were established. Second, economic impacts of drought on selected economic indicators such as quantities of staple food crop, average food value production, number of undernourished people, gross domestic product, agriculture value added growth, and renewable water resources per annum in Kenya were evaluated. Third, different climate change adaptation measures among farmers in Makueni county were identified using focused group discussions and in-depth interviews, for which the use of bottom-up approach was used to elicit responses. Findings from the binary logistic regression model show a statistical relationship between drought events and a selected set of economic indicators. More specifically, drought events have led to increased use of pesticides, reduced access to credit for agriculture and the annual growth of gross domestic product. One of the main recommendations of this chapter is to involve farmers in designing and implementing community-based climate change adaptation measures, with support from other relevant stakeholders.

---

**Keywords**

Drought · Agriculture sector · Logistic regression · Climate adaptation · Kenya

---

**Introduction**

The agriculture sector in sub-Saharan Africa accounts for about 30% of the gross domestic product (GDP) and 40% exports in the region (Calzadilla et al. 2013). The sector is characterized by rainfed extensive crop and pastoral systems with low yields below potential (Amjath-Babu et al. 2016). The overreliance on rainfed systems has made the region prone to impacts of increasing temperatures, declining precipitation, changes in surface water run-off, and increased carbon dioxide (CO<sub>2</sub>) (World Bank 2008). Low precipitation and high temperatures have reduced surface moisture content and increased evapotranspiration rates respectively causing soil degradation. Frequent weather-related disasters such as floods, droughts, tropical cyclones, and landslides have led to deaths and loss of livelihoods (Lumbroso 2017).

Drought is one of the most recurring climate change disasters for countries on the horn of Africa. This extreme weather event has occurred due to lack or inadequate precipitation leading to water shortage for plants, human, and animal consumption (Muller 2014; Maity et al. 2016). Its occurrence has been associated with global climate change, as there exist scientific evidence associating increased human activities with global climate change shocks such as floods and droughts (IPCC 2007). There are four types of droughts: meteorological (shortage in rainfall),

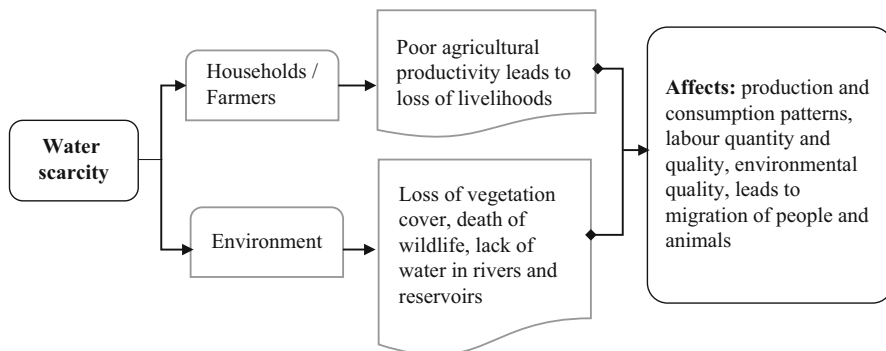
hydrological (insufficient water in rivers and reservoirs), agricultural (inadequate soil moisture), and socioeconomic droughts (Maity et al. 2016).

In sub-Saharan Africa, droughts are common and their economic impacts in general have not been adequately studied. The reason behind this could be the complex nature of drought as it presents complex effects to lives on earth (Wang et al. 2014). Drought accounts for about 5% of the natural disasters but the losses that it causes account for about 30% of what is caused by other natural disasters (Wang et al. 2014). It aggravates water scarcity problem by affecting both surface and groundwater resources leading to reduced water supply, quality, and disruption of wetlands (Mishra and Singh 2011). When it persists for months or years, it causes conflicts between pastoral communities due to competition for the diminishing water and pasture resources (Uexkull 2014; Martin et al. 2016).

To demonstrate the economic impacts of drought, this chapter follows the framework by Freire-González et al. (2017). The authors establish many pathways and the drivers that contribute to the economic impacts of drought, which they classify into two categories: primary and secondary. The primary impacts of drought are those that affect economic agents such as industries, households, government, and the environment, while the secondary impacts lead to fires, desertification, and migration of people, as well as animals (Freire-González et al. 2017). Further, drought affects tangible assets such as land and vegetation cover differently from other natural disasters such as earthquakes, storms, or floods that affect buildings, machines, and other assets. In the long term, drought leads to soil degradation, damages to buildings due to soil sagging, as well as the ecosystems due to excessive groundwater abstractions without enough rainfall to replenish it (Freire-González et al. 2017). Drought leads to an increase in temperature causing excessive loss of water through evapotranspiration thus reducing water availability and quality. People are affected differently by drought depending on their geographical location (Freire-González et al. 2017). For example, the impact of drought on people in developing countries is more pronounced due to limited financial capacity to cope with effects such as malnutrition, starvation, increased pests and disease vectors such as malaria and dengue fever-causing mosquitoes (Freire-González et al. 2017), economic burden, and in extreme cases, death. Freire-González et al. (2017) framework focuses on how water scarcity caused by drought affects the households and the environment (Fig. 1).

It is important to focus on drought because it exacerbates the water scarcity situation, coupled with the fact that Africa is one of the driest continents in the world (Mishra 2014). Drought severely affects the water sector in many parts of SSA region, and the impact of the drought on the sector negatively affects the economy.

Some of the effects of drought on the agricultural productivity are also tabulated (Table 1), and the resulting socioeconomic impacts. The analysis gives a broad picture of the effects of drought on the agricultural productivity and the social aspects of the farmers. In some regions of America, the costs relating the effects of drought on the crop and livestock sectors among households have been quantified. For instance, Craft et al. (2017) carried out a study in Kentucky, USA, and reported a reduction in livestock and hay produced, estimated at a cost of \$143.4 due to



**Fig. 1** Impacts of water scarcity caused by drought on households and environment (Adapted from Freire-González et al. 2017)

**Table 1** Impacts of drought on agricultural productivity and resulting socioeconomic impacts

Description	Impacts on productivity	Socio-economic effects
Cropping systems	Shift planting and harvesting dates	High market food prices
	Partial or total crop failure	Starvation and malnutrition
	Decreased crop yields	Decrease in farmers’ income
Livestock	Decrease in forage from grasslands	Conflicts over pasture
	Increased livestock deaths	Decrease in household income
	Decrease in the quality of meat and milk	From livestock sales
Soil properties and soil health	Insufficient soil moisture for plant growth	Loss of vegetation cover
	Death of soil micro-organisms	Desertification
Hydrological cycle	Reduced water levels in rivers and reservoirs or no water at all	Increase in water prices
	Water scarcity	Conflict over scarce water and pasture resources

water shortage caused by drought. However, the quantitative analysis of the impacts of drought on livestock and crop production in SSA has not yet been estimated due to paucity of available data and research capacity. In the context of SSA, a general qualitative analysis based on previous studies such as Wang et al. (2014), Kusangaya et al. (2014), and Adams et al. (1998) is used in this chapter to draw a close context.

## Climate Change Adaptation Measures in the Agriculture Sector of Sub-Saharan Africa

Climate change adaptation is one of the coping strategies supported by the United Nations Framework Convention on Climate Change (UNFCCC) to help developing countries, to reduce the negative effects of climate change (UNFCC 2015;

Deressa et al. 2009). Countries in sub-Saharan Africa express their adaptation needs in a policy document known as the Intended Nationally Determined Contributions (INDCs) (UNFCC 2015). The implementation of the INDCs is supported by several stakeholders such as government institutions, non-governmental organizations (NGOs), donor organizations, the World Bank, and the United Nations Environmental Programs involved in environment and climate change adaptation implementation in SSA region. These organizations have so far supported adaptation strategies in the agriculture sector such as small-scale irrigation of crop in areas where rains have failed, crop and livestock diversification, changes in planting dates, use of soil and water conservation techniques, namely terracing, mulching, and organic manure application (Nthambi et al. 2021; Bryan et al. 2013; Calzadilla et al. 2013; Francisco et al. 2010). Previous research has treated climate change adaptation measures in agriculture as a private good because this only involves individual farmers' adapting to the situation to reduce the local impacts of climate change (Lavoro 2010; Hasson et al. 2010). The effectiveness of these adaptation measures depends on the amount of resources available to support the adaptation process. Adaptation measures can, however, be categorized into two classes: autonomous and anticipatory (public). Autonomous adaptation measures are adjustments to respond to climate variability such as (rainfall) by individual farmers. This could be adopting suitable cropping types, changes in planting dates, and investment in irrigation technologies among other strategies (Calzadilla et al. 2013).

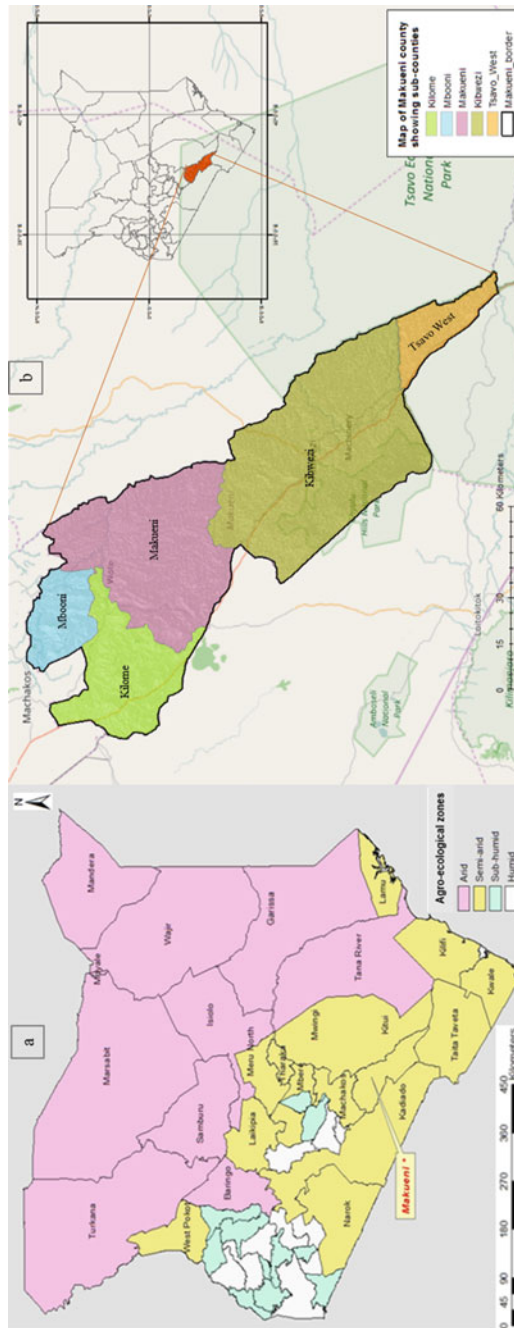
Anticipatory (public) adaptation is a planned measure to respond to climate change which is based on a public policy characterized by acceptability, flexibility, and net benefits (Dinar et al. 2008, c.f. Calzadilla et al. 2013). There are already existing studies from different countries in SSA region that have suggested autonomous adaptation measures (Alemayehu and Bewket (2017); Gebrehiwot and van der Veen (2013); Tessema et al. (2013); Deressa et al. (2011); Amdu (2010)). However, there are limited studies that have sought to address the anticipatory (public) climate change adaptation approach from both a scientific and public policy perspective.

---

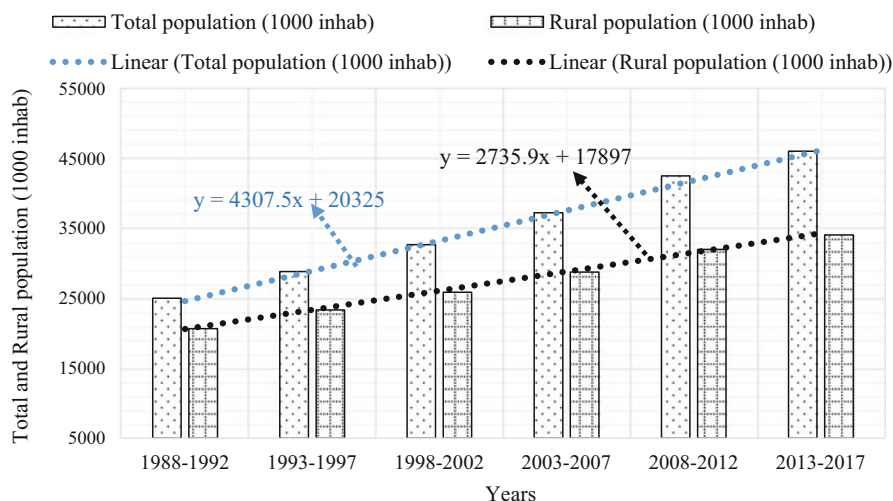
## Methodology

### Study Area

Kenya is one of the SSA countries in the East African region. It covers an area of 581,309 km<sup>2</sup>, which consists of 98.1% land and 1.9% water mass (GoK 2010). The agro-ecological zone distribution map of Kenya is shown in Fig. 2a, and this map identifies four main climate zones including humid, subhumid, semi-arid, and arid regions within the administrative map of Kenya. About 82% of the land mass represents arid and semi-arid areas (ASALs) (Kabubo-Mariara 2009; Rosenzweig et al. 2004), which are naturally prone to drought events. In Kenya, most



**Fig. 2** Map of Kenya showing (a) the distribution of agro-ecological zones across the counties and (b) the sub-counties in Makueni, the case area in Kenya



**Fig. 3** Total and rural population (1000 inhabitants) between 1988 and 2017 in Kenya (Data source: FAOSTAT 2017)

households found in the ASAL region have limited financial capability to respond to weather shocks such as the severe drought events (Ng'ang'a et al. 2016).

One of the counties in the ASALs region of Kenya in focus is Makueni County. It is situated in the eastern part of Kenya and lies between Latitudes  $1^{\circ} 35'$  and  $3^{\circ} 00''$  South and Longitudes  $37^{\circ} 10' E$  and  $38^{\circ} 30' E$ . It covers an area of  $8034.7 \text{ km}^2$  (GoK 2013) I has four sub-counties (Fig. 2b). Households in Makueni County hold a base area of 1.58 hectares which is more in comparison to the national household land holding size of 0.97 hectares. The area experiences a bimodal rainfall pattern of between 300 mm and 1200 mm/annum (GoK 2013). The County's average temperature ranges between  $20.2^{\circ} \text{C}$  and  $35.8^{\circ} \text{C}$  (SACRED AFRICA 2011). It is prone to frequent droughts which are caused by inadequate rainfall leading to loss of fodder and food crop productivity. The drought events affect crop farming in the lower areas of the County making the communities living there to take a shift from crop production to animal production (GoK 2013).

One of the main drivers of climate change in Kenya is land degradation resulting from unsustainable land use practices due to a growing population. Land degradation occurs mainly due to the excessive conversion of woodlands into agricultural and settlement areas to cater for the increasing demand for food and shelter among households (Shadeed and Lange 2010). The estimated population in Kenya is approximately 46 million people out of which 34 million people live in rural areas (FAOSTAT 2017). Since the late 1980s, there has been an increasing population trend in the rural areas and the total number of inhabitants in Kenya (Fig. 3). The increase in rural population (Fig. 3) means an increasing dependence on agricultural activities to sustain the daily livelihood of the rural populace.



Muriuki et al. (2011) argue that the population growth in Kenya over the years has led to the massive movement of people from humid and sub-humid areas to arid and semi-arid areas. Resulting land degradation from these migrations has partly contributed to increased temperature and drought frequencies in Kenya since has potential to cause an interruption to the hydrological and ecosystem cycles.

## Methods

The selected data mined from databases of the World Bank and the UN FAO websites to evaluate the impact of drought consisted of climate indicators (temperature and rainfall values), population size, average food value, number of undernourished persons, renewable water resources, agriculture value added annual percentage growth, pesticide use, producer prices (US dollars), credit to agriculture (US dollars), and annual % growth of GDP for a period of over 20 years. The time series trend analyses of rainfall, temperature, population size, average food value, number of undernourished persons, renewable water resources, and agriculture value added annual percentage growth were done. Logistic regression model of the economic indicators (pesticide use, producer prices (US dollars), credit to agriculture (US dollars), and annual percentage growth of GDP) datasets were implemented in STATA to demonstrate the relationship between drought events and the selected variables. A binary coding approach was adopted to separate the years when drought events occurred which were coded as 1 and 0 otherwise. The binary logit model estimates the relationship between drought and several other independent variables. The model is applied to variables which are within  $(0 \dots 1)$  and  $(-\infty \dots \infty)$  and is expressed in eqs. 1, 2 and 3 as specified in Bera et al. (2020).

$$c = \beta_0 + \beta_k x_k \quad (1)$$

$$c = \log_e \left[ \frac{P}{1-P} \right] = \text{logit}(P) \quad (2)$$

where  $P$  represents the probability of a drought event causing an impact to the agriculture sector.  $c$  represents the  $\text{logit}(P)$  and it is related to the independent variables.  $\beta_0$  denotes the constant value,  $\beta_k$  represents the coefficient estimates for the  $x$  factors.  $x_k$  represents selected indicators that explain the dependent variable. In terms of the probability that drought events influence the independent variables, the model can be formulated as follows:

$$P = \frac{\exp(\beta_0 + \beta_k x_k)}{(1 + \exp(\beta_0 + \beta_k x_k))} \quad (3)$$

To demonstrate the willingness of smallholder farmers to be involved in an appropriate anticipatory climate change adaptation strategy, focused group discussions were conducted among three population groups in Makueni County. The population consisted of farmer groups, NGOs dealing with agriculture and

environmental issues in each of the agro-ecological zones, and government institutions charged with the responsibility of food security and environmental protection. The selection of these three populations was guided by the Agricultural Sector Development Strategy (ASDS) 2009–2020. Six focused group discussions were conducted with six registered farmer groups (a total of 190 farmers; 60 males and 130 females) between February and March 2015. The semi-structured interviews consisted of 17 key informants from the NGOs and government institutions which were used to supplement the information obtained from the smallholder farmers in the focus group discussions. In both cases, farmers and officials of NGOs and government institutions were asked to identify different adaptation measures based on the status quo then.

---

## Results and Discussion

### Drought Identification and Historical Trend Analysis

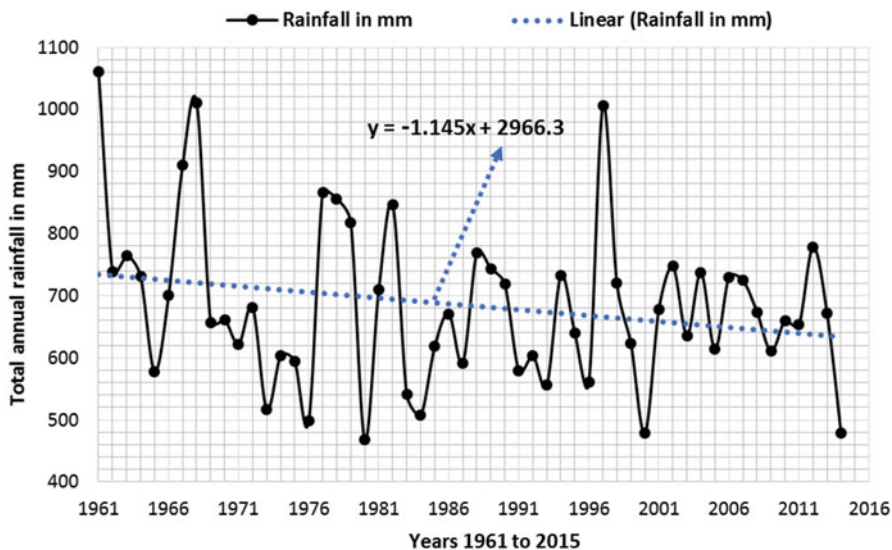
#### Drought Episodes

The meteorological drought is responsible for hydrological and agricultural droughts types in Kenya. However, a successful integrated water resources management can help prevent the socioeconomic drought caused by the two droughts types. The socioeconomic drought is driven by factors of demand and supply of crop and livestock products (AMS 1997). The meteorological drought events in Kenya recorded were experienced between 1991–2, 1992–3, 1995–6, 1998–2000, 2004, 2006, 2008–9 (Ochieng et al. 2016), 2010–11, 2014–15, and 2016–17 (Reliefweb 2017). These episodes affected the agriculture sector and posed a risk on the food production systems. They caused an imbalance in the production and consumption patterns, which are very important components of food security (Kogan et al. 2013; Li et al. 2009; Tubiello et al. 2007). Previous studies in Kenya show that the agriculture sector is adversely affected by drought events leading to water scarcity, food insecurity, and conflict among pastoral communities (Muriuki et al. 2011). In some cases, people, livestock, and wildlife have lost their lives through starvation (Ombis 2013). The most recent instances occurred on February 10, 2017, and the government of Kenya responded by declaring drought a national disaster. This is because 2.7 million people faced the risk of starvation and about 23 out of a total of its 47 Counties were alarm areas, requiring urgent food and water aid (Reliefweb 2017). The declaration simply means high opportunity costs of other sectoral developments would be lost in pursuing food and cash transfers to the affected people in areas such as the Southeast, coastal lowlands, and the northern parts of the country. Although these impacts of drought are real in Kenya, there are limited scientific documentation to evaluate the impact of drought due to paucity of data. Moreso, there is limited literature which have studied the frequent droughts and linked them to the historical changes in the rainfall and temperature trends in the area.

## Rainfall Trends

Over the past decades, scientists have carried out studies demonstrating how rainfall variability and increase in temperature have affected the agriculture sector and/or have a likelihood of causing catastrophes in the future. In East Africa, the annual rainfall amounts have declined considerably since the 1990s thus marking the region with frequent severe droughts between 2004–2005, 2009–2011 (Bloszies and Forman 2015) and 2014–2017 (Reliefweb 2017). The severe droughts have caused failures in rainfed crop production systems leading to food insecurity, famine, and political instability in most parts of northern Kenya, and other countries on the horn of Africa such as Ethiopia, southern Sudan (Bloszies and Forman 2015), and Somalia. Kenya has two main rainy seasons between January to May and October to December and a dry season from June to August. However, since the 1960s the amounts of rainfall received have reduced and are expected to reduce in the coming years. Trend analysis of data from World Bank (2017) database demonstrates a declining trend of precipitation and a high variability of rainfall characterized by extreme highs and lows over the past 55 years (Fig. 4).

A Kolmogorov-Smirnov (K-S) on the rainfall data from 1961 to 2016 indicates a normal distribution of rainfall. However, a Mann-Kendall (MK) statistic test at 95% and 99% indicate significant annual and seasonal variations of rainfall. The changes in seasonal and annual variations represent a reducing rainfall trend (Fig. 4). The trendline in the illustration indicates decreasing rainfall trend (see blue dotted linear) over time. A further decline may be expected if the diagram does not take into account the years of El Niño/Southern Oscillation (ENSO) rains which represent a climate change shock. For instance, the El Niño rains caused massive flooding and



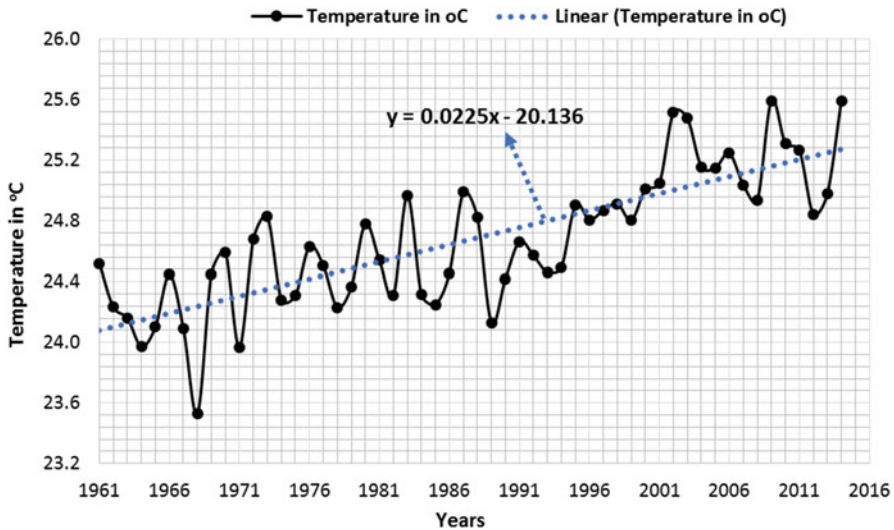
**Fig. 4** Total annual rainfall in mm between 1961 and 2014 in Kenya (Data source: World Bank 2017)

mudslides in 1998 (Bloszies and Forman 2015). The severe floods in 1998 caused deaths, extensive damage to infrastructure leaving many households isolated and displaced (FAO 1998). If the years of El Niño rains are excluded from Fig. 4, the rainfall trend would probably be expected to decrease further.

### Temperature Trends

Since the 1960s the mean annual temperature in Kenya has increased by 1.0 °C at a mean rate 0.21 °C per decade. The increase is higher between March and May (0.29 °C) and low between June and September (0.19 °C) per decade (World Bank 2017). In the last 55 years, trend analysis of temperature data from the World Bank (2017) has increased by 1.1 °C. The increase in temperature affect the agriculture sector as the soil organic matter is depleted leading to degradation (Kirschbaum 1995). Soil degradation affects crop growth, and causes poor production yield. This is because there is a high correlation between soil organic carbon pool and climate (Kirschbaum 1995). The increase in temperature leads to an increase in humidity in the atmosphere due to high evapotranspiration rates (Tian and Yang 2017). The analysis of the temperature time series of Kenya is illustrated in Fig. 5. The result of the trend in the temperature changes is expected to increase further as shown by the trend (blue dotted linear line) line. The temperature increase in Kenya explains the local warming and drying of the country which has manifested in the form of frequent severe drought events since the 1990s.

Global warming has been associated with increased drought frequencies over the last five decades in Kenya. Yin et al. (2014) argue that the dry to very dry areas have doubled in the world due to effect of rising temperature. In Kenya, it is evident that



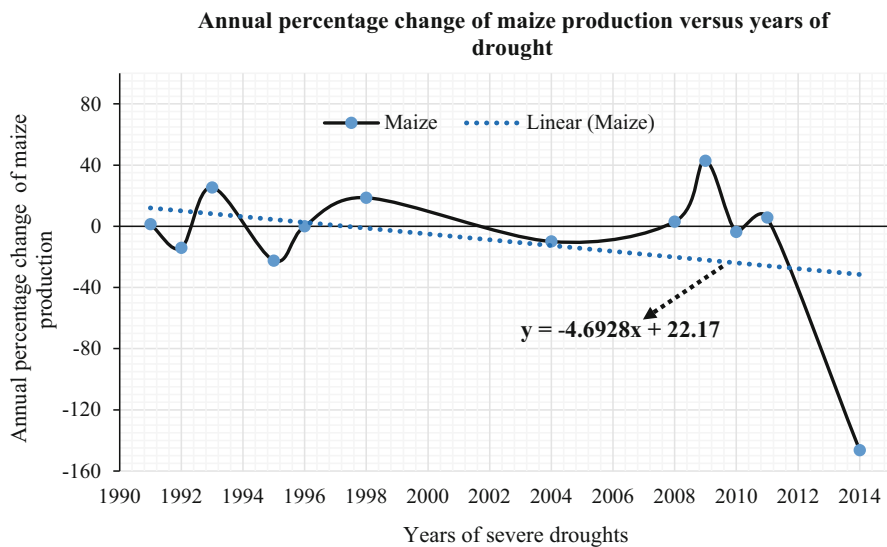
**Fig. 5** Mean annual temperature between 1961 and 2014 in Kenya (Data source: World Bank 2017)

the temperature increase has led to further drying in many parts of the arid and semi-arid region, for example, in the south-east, coastal areas, and northern parts of the country. This has increased the cases of land-related conflicts, as viable agricultural crop lands encroach into meadows meant for animals of pastoralists who graze in these areas (Reliefweb 2017).

## Evaluation of Economic Impacts of Drought on the Agriculture Sector in Kenya

### Impact of Drought on Maize Production

The impact of the global climate change has been linked to the negative effects of economies, governance structures, and communities (Linke et al. 2015). Therefore, many developing economies and poor communities that depend on the agricultural produce can be badly affected due to the change. For instance, maize is one of the staple food crop in Kenya and contributes significantly toward food security (MALF 2017). The dwindling trend in its production since the 1990s can be attributed to severe droughts, especially during periods of drought episodes. To illustrate this, the trend in the annual percent change of maize yields corresponding to periods of drought between 1991 and 2014 declined (blue dotted trend line) (Fig. 6). The annual percentage changes in maize production were positive for the years when the drought events of 1991, 1993, 1998, 2008, and 2011 occurred. They became negative in 1992, 1995, 2004, 2010, and 2014 and zero for drought event of 1996.



**Fig. 6** Annual percentage change in maize production between 1991 and 2014 in Kenya (Data source: FAOSTAT 2017)

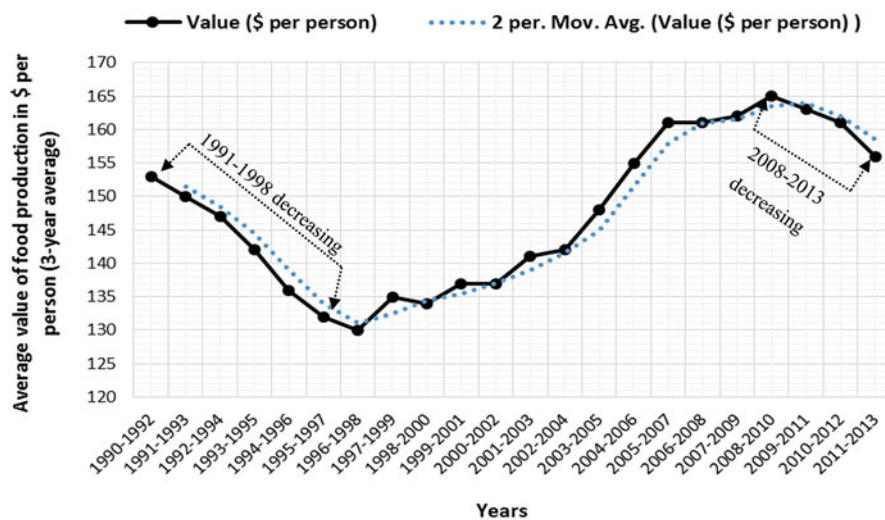
During these drought events there were low maize yields and this led to increase in maize prices and higher demand for substitute food types such as rice, wheat, and root crops among others. The increased demand in the substitute food crop for the staple maize, forced the prices of these crop to go higher.

### Impact of Drought on the Average Food Value Production

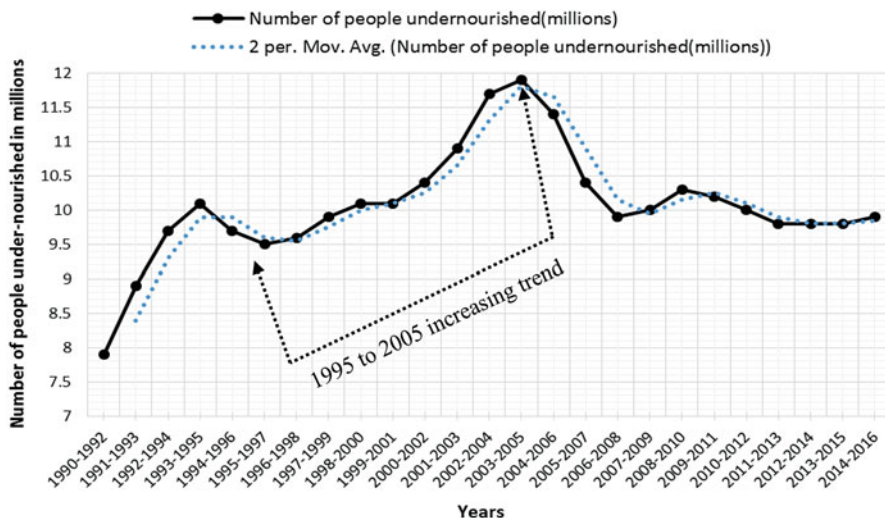
Drought affects the average value of food production expressed in dollars per capita. Average value of food production is a country-wide measure of the absolute economic size of the food production sector (Land Portal 2018). The relationship between rainfalls and average food value revealed that there were drought events between 1991–1998 and 2008–2013. During this period, the average food value in dollars per capita followed a declining trend (Fig. 7). The average food value indicator is estimated over 3 years moving average to reduce the impacts of production errors resulting from complexities that occur due to disparities in major food stocks (Land Portal 2018). The two-person moving average curve (blue dotted curve) in Fig. 7 smoothens the short-term fluctuations in the average food value and shows an increasing or decreasing trend in the long term.

### Impact of Drought on the Number of Undernourished People

The agriculture sector in Kenya provides means of livelihood to more than 80% of the population (Faostat 2019). The population of undernourished people between 1990 and 2016 remained relatively high corresponding to the period of drought episodes in the country. These numbers of people are estimated to be in danger of calorie inadequacy and are under hunger threat (World Hunger Education Service 2016). They are thus at a risk of malnourishment. The analysis of the data revealed that the number of



**Fig. 7** Average value of food production in dollars per person (3 – year average) in Kenya (Data source: FAOSTAT 2017)



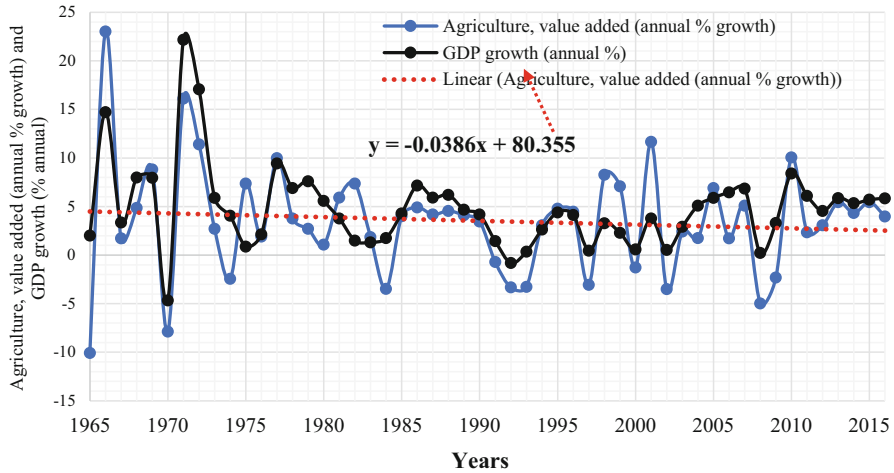
**Fig. 8** Number of undernourished people in millions (three-years average) in Kenya (Data source: FAOSTAT 2017)

undernourished people has been fluctuating, but relatively increasing in number, as shown in the trend plot (Fig. 8). For instance, between 1995 and 2005 there is a noticeable increase in the number of people under the threat of hunger in Kenya due to the 11 drought events that occurred between 1995 and 2005. The implication of this fact is that frequent severe drought events can be a threat to the Sustainable Development Goal (SDG 2) of the United Nations on the eradication of hunger and malnourishment because drought limits food availability to the people.

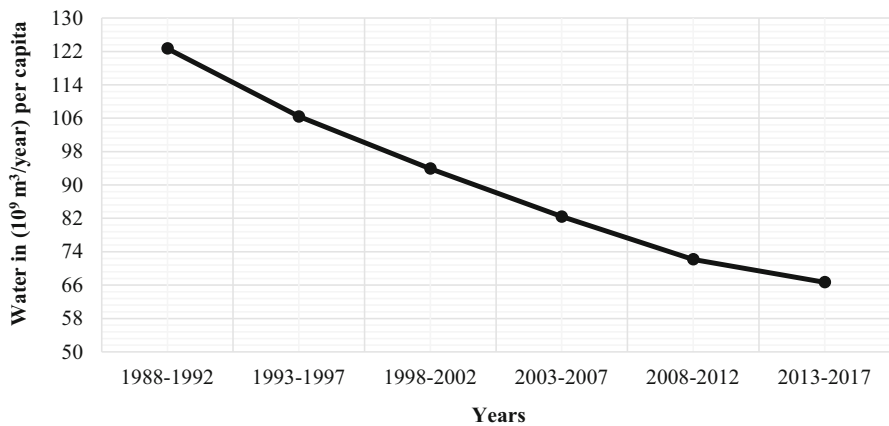
Thus, the number of undernourished people in Kenya have remained high regardless of efforts to meet SDG 2 of ensuring zero (0) hunger. Ensuring zero (0) means ending hunger by achieving food security through access to the right amounts and quality of food from sustainable agricultural practices. To understand the relationship between food and drought, or hunger and water scarcity can be correlated as common phenomena (Loewenberg 2014). This is due to overreliance on rain-fed agriculture which is highly vulnerable to the frequent severe droughts in Kenya. An estimated 75% of the population in the country derive their livelihoods from crop and livestock production (Loewenberg 2014), half of whom survive on less than a dollar a day. People who live on less than a dollar a day to meet their food and water needs are said to be poor (Nthambi et al. 2021; Loewenberg 2014).

### Impact of Drought on the Gross Domestic Product (GDP)

The agriculture sector contributes approximately 25.9% to the GDP in employment and in providing food to local communities in Kenya (Ochieng et al. 2016). This means that the impact of drought on the agriculture sector is likely to affect the national GDP. Data from the World Bank (2017) show that agriculture, value-added annual % growth values are negative during the years of drought in Kenya. For example, the annual % growth for the valued added in agriculture 1991 (-1%), 1992



**Fig. 9** Agriculture, value added annual % growth versus GDP annual % growth between 1965 and 2016 in Kenya (Data source: World Bank 2017)



**Fig. 10** Total renewable water resources in m<sup>3</sup> per capita in Kenya (Data source: FAOSTAT 2017)

(−3%), 1993 (−3%), 2008 (−5%), and 2009 (−2%) (Fig. 9). The agriculture, value-added annual % growth describes the net value output of the agriculture sector obtained by summing up all the outputs minus intermediate inputs. When agriculture, value-added annual % growth curve is compared with that of the GDP % annual growth in Kenya for the period between 1965 and 2016, the curves behave similarly. That is, as agriculture, annual % growth increases, the GDP annual growth % also increases and vice versa (Fig. 9). These trends suggest that the agriculture sector correlates linearly to the GDP. This means that the impact of drought on the agriculture sector will lead to negative value-added annual % growth, which in turn leads to the reduction of the GDP annual growth %.



### Impact of Drought on Water Security

Kenya is water-scarce and has only about 3–4% of its land cover composed of wetlands. The country experiences loss of wetlands estimated at 7% per annum due to the expansion of land for crop and livestock production (Böhme et al. 2016). Therefore, severe droughts have led to decline in surface and groundwater recharge. The total renewable water resources per capita per year between 1988 and 2017 have followed a declining trend (Fig. 10). Total renewable water resources are internal and external water resources (both surface water and groundwater) generated through the hydrological cycle (FAO 2016). The internal water resources are generated through endogenous precipitation while external water resources are the resources that enter the country through the transboundary flow from external surface and groundwater resources (FAO 2016). With the total renewable water resource being finite and the population continuing to grow, the water consumption per capita will dwindle. The drought events will have very harsh impact on the population. Hence, alternative water sources and conservation techniques are required to supplement the deficits caused by the drought.

### Statistical Analysis of Drought Impact on Selected Economic Indicators

Table 2 shows the descriptive statistics of the dataset obtained from FAOSTAT 2019, consisting of some economic indicators used in the binary logit regression model. These indicators represent independent variables that were hypothesized to be influenced by drought in the agriculture sector. The producer prices represent the average cost of producing a ton of maize – the staple food crop per annum. The annual growth of GDP (%) is the macroeconomic indicator representing the status of the economy in which agriculture, forestry, and fisheries are major contributors. Credit to agriculture represents the average amounts of loans that producers in the agriculture sector, forestry and fisheries, household producers, cooperatives, and agro-businesses have borrowed from private/commercial banking sectors per year (FAOSTAT 2019) to support agricultural production.

Regression results (Table 3) show that pesticide use has a positive relationship with drought events while the coefficient estimates of producer prices, number of undernourished persons, GDP, and credit to agriculture have a negative relationship with drought events.

**Table 2** Descriptive statistics of economic indicators influenced by drought from 1991 to 2016

Economic indicators	Mean	Standard deviation
Pesticide use in tons	0.44	0.26
Producer prices (US dollars)	224.38	84.39
Number of under-nourished persons	10.15	0.86
Annual growth in gross domestic product (%)	7.59	12.023
Credit to agriculture (US dollars)	387.69	273.61

**Table 3** Summary of the results of the binary logit regression model

Choice (drought/no drought)	Coefficient	Std. Err	z	P >  z	95% Conf. Interval
Pesticide use	9.787	2.956	3.31	0.001***	3.993
Producer price	-0.024	0.0131	-1.85	0.064	-0.050
Undernourished	-1.467	0.9917	-1.48	0.139	-3.411
GDP	-0.176	0.0619	-2.85	0.004***	-0.298
Credit resources	-0.013	0.0047	-2.73	0.006**	-0.022
Constant	-1979.512	11.857	-166.94	0.000	-2002.8
Number of observations	26				-1956.3
Wald chi <sup>2</sup> (5)	158.7				
Prob > chi <sup>2</sup>	0.000				
Log likelihood	-12.659				

Pesticide use has a positive coefficient of variation and significant relationship with drought events. Increasing drought episodes means increased use of pesticides to control disease causing pests and vectors.

During drought events, soil moisture reduces the level of pesticide uptake. Moisture-deficient crops attract insects as such crops are unable to produce metabolites that prevent them from being susceptible to pest attacks (Yihdego et al. 2018). The annual growth percent of GDP is negative and statistically significant to drought events. Drought decreases food availability leading to decline in agriculture value added %. During drought events, farmers' ability to borrow money to support agricultural inputs declines as collateral for loans in form of farm assets becomes less available and valuable.

## Identified Climate Change Adaptation Measures in Makueni County

### Autonomous Climate Change Adaptation Measures

Makueni county has pilot private ponds already in place that are owned by a few households (Fig. 11a, b). Water accumulates in the ponds during the rainy season, and the farmers use it to irrigate the farm and/or fish farming. A standard water pond



**Fig. 11** Water ponds for harvesting during rainwater (a) dry season and (b) filled pond in the rainy season (Photos taken by Mary)



**Fig. 12** An example of a household owned water pond for irrigating a kales/vegetable garden showing (b) drip and (c) furrow irrigation (Photos taken by Mary)

holds a minimum of 200,000 L of water and can be used by an individual farmer to farm an acre of maize and vegetables for approximately three seasons (Fig. 12). However, the disadvantage of this adaptation measure is that most farmers are unable to purchase the polythene sheet used as an inner lining of the water pond because it is costly (KES 70,000 exchange rate @ 103.2270 KES = 1 USD as at June 2015). The plastic layer is used to prevent the harvested rainwater from permeating into the groundwater. However, these water ponds can be a health hazard and that can lead to the drowning of livestock and children if not well guarded, as well as act as a breeding ground for malaria-causing mosquitoes.

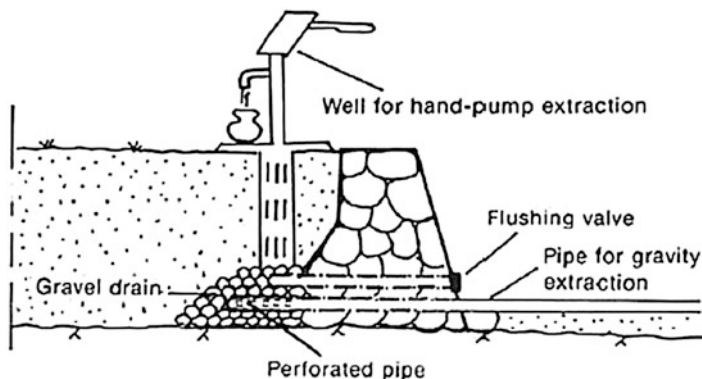
### Anticipatory Climate Change Adaptation Measures

Anticipatory climate change adaptation coping strategies to climate change are those public adaptation measures provided to the rural communities through the support of organized groups such as the farmer networks/groups, NGOs, and government institutions. These measures are in most cases capital intensive and might require highly skilled technical input to put them in place. A universal set of community-based water projects suggested include boreholes, earth dams, shallow wells, water tanks, subsurface, and sand storage dams. The communities chose a sand storage dam as the best option because of the following reasons; (1) it is the world's cheapest way of providing rainwater to communities in arid and semi-arid areas, (2), a sand storage dam creates an indigenous, reliable, clean water supply up to about 1000 people, (3), water sinks through the sand to the bedrock preventing it from evaporation and pollution as compared to water in shallow wells, and (4) it saves farmers a lot of stress regarding land disputes since it is constructed along seasonal rivers which are owned by the government and (5) sand storage dam reduces the risk of flooding and increases chances of water availability during the dry seasons. A sand dam is constructed across a shallow riverbed such as an ephemeral stream and water is extracted using pumps. An example of sand dam is shown in the following photograph (Fig. 13).

A subsurface sand dam is an underground facility that can be used as an alternative to the surface dams. It has some advantages over the conventional surface

**Fig. 13** A sand storage dam construction in Makueni County during the dry season (Photo taken by Mary)





**Fig. 14** Cross-section of water extraction from a sand-storage dam (modified from Hanson and Nilsson 1986)

dam because it prevents excessive loss of water through evaporation and does not support the breeding of vectors such as malaria-causing mosquitoes on it. However, the subsurface dam is constructed below the ground level to tap from the flowing groundwater in the natural aquifers. It also has enhanced surface permeability to cause faster infiltration of rainwater to the groundwater during the rainy season. The sand-storage dam stores water in the sand which accumulates naturally behind a dam wall (Onder and Yilmaz 2005). The wall constructed across the seasonal river should be tight and stable to withstand the pressure of running water downstream. The riverbanks of the sand storage dam ought to be protected from erosion on sloppy areas and the dam bottom (Nilsson 1988). According to Hanson and Nilsson (1986), the extraction of the water from the sand storage dam can either be through pumping or gravity. The use of gravity means a drain is placed at the reservoir bottom in the upstream direction of the sand storage dam or a pipe downstream as shown in Fig. 14. The construction of a sand storage dam has four stages: the first stage deals with the capacity of the dam. It is described by the height of the dam wall to be constructed and the quantity of water it is expected to hold.

The second stage involves a careful selection of a proper water pumping mechanism and how to incorporate it into the sand storage dam design. The third step involves the protection of the dam banks through the planting of trees on the sloppy areas both downstream and upstream of the river where the sand storage dam is constructed. The fourth stage involves a careful selection of the donor (management structure) to support the construction of the wall and one that would organize the farmers who will be involved in the construction process. The loss of benefit accruing from the choice of management structure in the area has been fully documented in Nthambi et al. (2021). Farmers should be involved in the four phases and the actual construction process of the selected climate adaptation measure. Other forms of participation can be accounted through contribution of labor time or cash for the purchase of raw materials.

## Conclusions

The frequent severe drought events in SSA region have heavily affected the growth of the agriculture sector, forcing crop and livestock farmers to work under very dry conditions in countries such as Kenya. In this chapter, the impacts of drought on the economy of Kenya were discussed, and a possible climate change adaptation measures demonstrated using a case study area in one of the counties. The findings can be summarized in three main ways. First, the analyzed climate indicators revealed frequent drought episodes, which have led to direct and indirect economic impacts on the agriculture sector and the economy. The analysis shows drought events have a positive relationship with pesticide use and negative relationship with credit resources, producer prices, number of undernourished people, and annual percentage growth of gross domestic product (GDP). Again, drought events negatively affect the number of undernourished people as the quantities of crop yields, for example, maize as the staple food crop in Kenya reduces. During the years of drought events, the agriculture value added % growth declines reducing the annual GDP. Producers and households' access to credit resources reduce during drought episodes. The amount of water from renewable water resources also declines due to decreasing rainfall amounts causing water scarcity.

Second, farmers and households can adapt to the negative impacts of drought using either autonomous or anticipatory climate adaptation measures. The major concern is the dryness that comes with drought events, and given the arid and semi-arid nature in most parts of Kenya, rainwater harvesting in sand dams would be the most suitable adaptation measure to reduce the impact of drought. Generally, farmers in the area prefer a sand dam over water ponds or boreholes. However, the lack of financial support hamper farmers' desire to execute this type of anticipatory climate change adaptation measure.

Third, from a methodological perspective, the use of available secondary data to avail important literature required for climate change research in SSA region was promoted. It demonstrates a simple way of relating climate variables with economic indicators using existing qualitative and quantitative approaches. In terms of determining suitable climate change adaptation measures, we consulted stakeholders to suggest the adaptation measures and propose a practical approach to implement them.

Two main recommendations were suggested in this chapter. First, the Kenya National Adaptation Plan (NCCAP) 2015–2030 highlights financing as one of the limitations in the mainstream of climate change adaptation in the water sector. The country is keen on providing adequate water management strategies that can ameliorate the water scarcity problem caused by drought events. We established the involvement of stakeholders to participate in constructing sand dams to harvest rainwater across seasonal rivers. Thus, the NCCAP, 2015–2030 should integrate community participation strategy to provide local materials such as water, sand, and stones or cash when possible, as a way for farmers to partially finance the provision of adaptation measures for sustainable water harvesting techniques. A bottom-top approach to adaptation measure is necessary to understanding farmers' willingness

to take part in adaptation projects such as the construction of a sand dam in the SSA region.

The National Drought Management Authority (NDMA) in Kenya, charged with the responsibility to identify risks, end drought emergencies, and ensure adaptation for sustainable livelihoods, should encourage farmers to form community-based organizations. NDMA should also encourage farmers to form farmer networks/groups and register them under the Self-help Association Bill (2015) to provide legal protection to farmers who wish to participate in sand storage dam construction. Membership of community-based organization would encourage collective action efforts that enhance trust among farmers thus strengthening stakeholders' participation in community adaptation projects. Government institutions and non-governmental organizations should work with farmer networks to ensure adaptation measures are implemented in a way that is acceptable to the communities that benefit from them.

---

## References

- Adams MR, Hurd BH, Lenhart S, Leary N (1998) Effects of global climate change on agriculture: an interpretative review. *Clim Res*:19–30
- Alemayehu A, Bewket W (2017) Determinants of smallholder farmers' choice of coping and adaptation strategies to climate change and variability in the central highlands of Ethiopia. *Environ Dev*:77–85
- Amdu B (2010) Analysis of farmers' perception and adaptation to climate change and variability: the case of Choke Mountain, east Gojjam., Available via <http://docplayer.net/60845560-Analysis-of-farmers-perception-and-adaptation-to-climate-change-and-variability-the-case-of-choke-mountain-east-gojjam.html>. Accessed 21 Jan 2018
- American Meteorological Society (1997) American meteorological society policy statement: meteorological drought bulletin. *Am Meteorological Soc* 78:847–849
- Amjath-Babu TS, Krupnik TJ, Kaechele H, Aravindakshan S, Sietz D (2016) Transitioning to groundwater irrigated intensified agriculture in sub-Saharan Africa: an indicator-based assessment. *Agri Wat Manag* 168:125–135
- Bera B, Saha S, Bhattacharjee S (2020) Forest cover dynamics (1998 to 2019) and prediction of deforestation probability using binary logistic regression (BLR) model of Silabati watershed, India. *Trees, Forests and People* 2:100034
- Bloszies C, Forman SL (2015) Potential relation between equatorial sea surface temperatures and historic water level variability for Lake Turkana, Kenya. *J Hydrol* 520:489–501
- Böhme B, Becker M, Dieckkrüger B, Förch G (2016) How is water availability related to the land use and morphology of an inland valley wetland in Kenya? *Phy Chem Earth, Parts A/B/C* 93:84–95
- Bryan E, Ringler C, Okoba B, Roncoli C, Silvestri S, Herrero M (2013) Adapting agriculture to climate change in Kenya: household strategies and determinants. *J Env Manag* 114:26–35
- Calzadilla A, Zhu T, Rehdanz K, Tol RSJ, Ringler C (2013) Economywide impacts of climate change on agriculture in sub-Saharan Africa. *Ecol Econ* 93:150–165
- Craft KE, Mahmood R, King SA, Goodrich G, Yan J (2017) Droughts of the twentieth and early twenty-first centuries: influences on the production of beef and forage in Kentucky, USA. *Sci Total Environ* 577:122–135
- Deressa T, Hassan RM, Alemu T, Yesuf M, Ringler C (2009) Analyzing the determinants of farmers' choice of adaptation methods and perceptions of climate change in the Nile Basin of Ethiopia. *Glob Environ Chang* 19:248–255

- Deressa TT, Hassan, RM, Ringler C (2011) Perception of and adaptation to climate change by farmers in the Nile basin of Ethiopia. *J Agr Sci* 149 (1):23–31
- Dinar A, Hassan R, Mendelsohn R, Benhin J (2008) Climate change and agriculture in Africa: impact assessment and adaptation strategies. EarthScan London series
- FAO (1998) Global information and early warning system on food and agriculture, special report. <http://www.fao.org/docrep/004/w7832e/w7832e00.htm>. Accessed 10 Jul 2017
- FAO (2016) Food and Agriculture Organization of the United Nations: In Statistics. <http://www.fao.org/nr/water/aquastat/data/query/index.html?lang=en>. Accessed 19 Sep 2017
- Faostat (2017) Food and Agriculture Organization of the United Nations: In Statistics <http://www.fao.org/faostat/en/> Accessed 25 Jul 2017
- Faostat (2019) Credit to agriculture. <http://www.fao.org/faostat/en/#data/IC>. Accessed 10 Dec 2019
- Francisco A, Fredrik C, Maria AN (2010) Farmers' adaptation to climate change. A framed field experiment. Environ for Dev Discussion paper series <http://www.rff.org/files/sharepoint/WorkImages/Download/EfD-DP-09-18-REV.pdf>. Accessed 20 Sep 2017
- Freire-González J, Decker C, Hall JW (2017) Methodological and ideological options. The economic impacts of droughts: a framework for analysis. *J. Ecol Econ* 132:196–204
- Gebrehiwot T, van der Veen A (2013) Climate change vulnerability in Ethiopia: disaggregation of Tigray region. *J E Afr Studies* 7(4):607–629
- GoK (2010) Constitution of Kenya. <http://www.kenyalaw.org/lex/actview.xql?actid=Const2010>. Accessed 18 Mar 2017
- GoK (2013) Makeni County Annual Development plan 2013–14. <http://makueni.go.ke/sites/default/files/2013%20Annual%20Development%20Plan.pdf>. Accessed 19 Mar 2017
- Hanson G, Nilsson A (1986) Ground-water dams for rural-water supplies in developing countries. *Groundwater* 24(4):497–506
- Hasson R, Löfgren Å, Visser M (2010) Climate change in a public goods game: investment decision in mitigation versus adaptation. *J. Ecol Econ* 70:331–338
- IPCC (2007) IPCC Fourth Assessment Report (AR4). [https://www.ipcc.ch/publications\\_and\\_data/publications\\_ipcc\\_fourth\\_assessment\\_report\\_wg1\\_report\\_the\\_physical\\_science\\_basis.htm](https://www.ipcc.ch/publications_and_data/publications_ipcc_fourth_assessment_report_wg1_report_the_physical_science_basis.htm). Accessed 6 Apr 2018
- Kabubo-Mariara J (2009) Global warming and livestock husbandry in Kenya: impacts and adaptations. *J Ecol Econ* 68:1915–1924
- Kirschbaum MUF (1995) The temperature dependence of soil organic matter decomposition and the effect of global warming on soil organic C storage. *Soil Bio Biochem* 27(6):753–760
- Kogan F, Adamenko T, Guo W (2013) Global and regional drought dynamics in the climate warming era. *Rem Sen Letters* 4(4):364–372
- Kusangaya S, Warburton ML, Garderen EMV, Jewitt GPG (2014) Impacts of climate change on water resources in southern Africa: a review. *Phys Chem Earth* 67-69:47–54
- Land Portal (2018) Average value of food production (constant I\$ per person) (3-year average). <https://landportal.org/book/indicator/fao-21011-612>. Accessed 10 Aug 2017
- Lavoro ND (2010) Adapting and mitigating to climate change: balancing the Choice under uncertainty. Sustainable dev Series: Fondazione Eni Enrico Mattei. <http://www.feem.it>. Accessed 29 July 2015
- Li Y, Ye W, Wang M, Yan X (2009) Climate change and drought: a risk assessment of crop-yield impacts. *Clim Res* 39(1):31–46
- Linke AM, O'Loughlin J, McCabe TJ, Tir T, Witmer FDW (2015) Rainfall variability and violence in rural Kenya: investigating the effects of drought and the role of local institutions with survey data. *Glob Environ Chang* 34:35–47
- Loewenberg S (2014) Breaking the cycle: drought and hunger in Kenya, special report. *Lancet* 383 (9922):1025–1028
- Lumbroso D (2017) How can policymakers in sub-Saharan Africa make early warning systems more effective? The case of Uganda. *Int J Disaster Risk Reduction* 27:530–540
- Maity R, Suman M, Verma NK (2016) Drought prediction using a wavelet-based approach to model the temporal consequences of different types of droughts. *J Hydrol* 539:417–428



- MALF (Ministry of Agriculture, Livestock and Fisheries) (2017) Economic Review of Agriculture (ERA). [http://www.kilimo.go.ke/wp-content/uploads/2015/10/Economic-Review-of-Agriculture\\_2015-6.pdf](http://www.kilimo.go.ke/wp-content/uploads/2015/10/Economic-Review-of-Agriculture_2015-6.pdf). Accessed 27 Mar 2017
- Martin R, Linstädter A, Frank K, Müller B (2016) Livelihood security in face of drought – assessing the vulnerability of pastoral households. *Environ Model Softw* 75:414–423
- Mishra AK (2014) Climate change and challenges of water and food security. *Int J Sustainable Built Environ* 3:153–165
- Mishra AK, Singh VP (2011) Drought modelling – a review. *J Hydrol* 403(1-2):157–175
- Muller JCY (2014) Adapting to climate change and addressing drought-learning from the red cross red crescent experiences in the horn of Africa. *Weather Climate Extremes* 3:31–36
- Muriuki G, Seabrook L, Seabrook L, McAlpine C, Jacobson C, Price B, Baxter G (2011) Land cover change under unplanned human settlements: a study of the Chyulu Hills squatters, Kenya. *Landsc Urban Plan* 99(2):154–165
- Ng'ang'a KS, Bulte EH, Giller KE, McIntire JM, Rufino MC (2016) Migration and self-protection against climate change: a case study of Samburu County, Kenya. *World Dev* 84(2016):55–68
- Nilsson A (1988) Groundwater dams for small-scale water supply. IT publications, London
- Nthambi M, Markova-Nenova N, Wätzold F (2021) Quantifying Loss of Benefits from Poor Governance of Climate Change Adaptation Projects: A Discrete Choice Experiment with Farmers in Kenya. *Ecol Econ* 179:106831
- Ochieng J, Kirimi L, Mathenge M (2016) Effects of climate variability and change on agricultural production: the case of small-scale farmers in Kenya. *NJAS –Wageningen J Life Sci* 77:71–78
- Ombis GO (2013) Study of climate change impacts using disaster risk reduction interventions to enhance community resilience, case of Makueni County. [http://erepository.uonbi.ac.ke/bitstream/handle/11295/71725/Ombis\\_Study%20of%20climate%20change%20impacts%20using%20disaster%20risk%20reduction%20interventions%20to%20enhance%20community%20resilience.%20Case%20of%20Makueni%20county..pdf?sequence=4](http://erepository.uonbi.ac.ke/bitstream/handle/11295/71725/Ombis_Study%20of%20climate%20change%20impacts%20using%20disaster%20risk%20reduction%20interventions%20to%20enhance%20community%20resilience.%20Case%20of%20Makueni%20county..pdf?sequence=4). Accessed 15 Apr 2018
- Onder H, Yilmaz M (2005) Underground dams. A tool of sustainable development and management of groundwater resources. *Eur Wat* 11(12):35–45
- Reliefweb (2017) Kenya: drought – 2014–2018. <http://reliefweb.int/disaster/dr-2014-000131-ken>. Accessed 15 Feb 2017
- Rosenzweig C, Strzepek KM, Major DC, Iglesias A, Yates DN, McCluskey A, Hillel D (2004) Water resources for agriculture in a changing climate: international case studies. *Global Environ Chang* 14:345–360
- SACRED AFRICA (2011) Sorghum marketing baseline survey for Nakuru and Makueni Counties for the KAPAP project technical report, Kenya Agricultural Productivity Programme [Unpublished report]
- Shadeed S, Lange J (2010) Rainwater harvesting to alleviate water scarcity in dry conditions: a case study in Faria catchment, Palestine. *Wat Sci Eng* 3(2):32–143
- Tessema Y, Aweke C, Endris G (2013) Understanding the process of adaptation to climate change by small-holder farmers: the case of east Hararghe zone, Ethiopia. *Agri Food Econ* 1(1):13
- Tian Q, Yang S (2017) Regional climatic response to global warming: trends in temperature and precipitation in the yellow, Yangtze and Pearl River basins since the 1950s. *Quat Int* 440:1–11
- Tubiello FN, Soussana JF, Howden SM (2007) Crop and pasture response to climate change. *Proc Natl Acad Sci USA* 104(50):19686–19690
- Uexkull NV (2014) Sustained drought, vulnerability and civil conflict in sub-Saharan Africa. *Pol Geog* 43:16–26
- UNFCCC (2015) Adoption of the Paris agreement. UNFCCC, Paris (2015) <https://unfccc.int/resource/docs/2015/cop21/eng/109r01.pdf>. Accessed 22 Sep 2017
- Wang Q, Wu J, Lei THB, Wu Z, Liu M, Mo X, Geng GLX, Zhou H, Liu D (2014) Temporal-spatial characteristics of severe drought events and their impact on agriculture on a global scale. *Quat Int* 349:10–21
- World Bank (2008) World development report 2008: agriculture for development. World Bank Washington, DC. [https://siteresources.worldbank.org/INTWDR2008/Resources/WDR\\_00\\_book.pdf](https://siteresources.worldbank.org/INTWDR2008/Resources/WDR_00_book.pdf). Accessed 12 Feb 2018

- World Bank (2017) Climate Knowledge Portal for Development Practitioners and Policymakers. retrieved from [http://sdwebx.worldbank.org/climateportal/index.cfm?page=downscaled\\_data\\_download&menu=historical](http://sdwebx.worldbank.org/climateportal/index.cfm?page=downscaled_data_download&menu=historical). Accessed 13 Jun 2017
- World Hunger Education Service (2016) World hunger and poverty facts and statistics 2016. <https://www.worldhunger.org/2015-world-hunger-and-poverty-facts-and-statistics/>. Accessed 10 Oct 2017
- Yihdego Y, Salem SH, Muhammed HH (2018) Agricultural pest management policies during drought: case studies in Australia and the state of Palestine. *Nat Hazards Rev* 20(1):05018010
- Yin Y, Zhang X, Lin D, Yu H, Wang J, Shi P (2014) GEPIC-V-R model: a GIS-based tool for regional crop drought risk assessment. *Agri Wat Manag* 144:107–119

**Open Access** This chapter is licensed under the terms of the Creative Commons Attribution 4.0 International License (<http://creativecommons.org/licenses/by/4.0/>), which permits use, sharing, adaptation, distribution and reproduction in any medium or format, as long as you give appropriate credit to the original author(s) and the source, provide a link to the Creative Commons license and indicate if changes were made.

The images or other third party material in this chapter are included in the chapter's Creative Commons license, unless indicated otherwise in a credit line to the material. If material is not included in the chapter's Creative Commons license and your intended use is not permitted by statutory regulation or exceeds the permitted use, you will need to obtain permission directly from the copyright holder.





# Rural Farmers' Approach to Drought Adaptation: Lessons from Crop Farmers in Ghana

# 52

Hillary Dumba, Jones Abrefa Danquah, and Ari Pappinen

## Contents

Introduction .....	1034
Study Areas .....	1035
Data Collection and Sampling Procedure .....	1036
Data Processing and Analysis .....	1037
Results and Discussion .....	1037
Farm Household Characteristics and Adaptation Capacity .....	1037
Constraints to Drought Adaptation .....	1039
Determinants of Adoption of Drought Adaptation Measures .....	1041
Conclusions .....	1048
References .....	1048

## Abstract

Sub-Saharan Africa is considered to be highly vulnerable to climate change-related disasters particularly drought. Farmers in Ghana have learnt to co-exist with it by resorting to various approaches. This study sheds light on farmers' adaptation to drought in Ghana. The cross-sectional survey design was used to

This chapter was previously published non-open access with exclusive rights reserved by the Publisher. It has been changed retrospectively to open access under a CC BY 4.0 license and the copyright holder is "The Author(s)". For further details, please see the license information at the end of the chapter.

H. Dumba

Institute of Education, College of Education Studies, University of Cape Coast, Cape Coast, Ghana

J. A. Danquah (✉)

Department of Geography and Regional Planning, Faculty of Social Sciences, College of Humanities and Legal Studies, University of Cape Coast, Cape Coast, Ghana  
e-mail: [jones.danquah@ucc.edu.gh](mailto:jones.danquah@ucc.edu.gh)

A. Pappinen

School of Forest Sciences, Faculty of Science and Forestry, University of Eastern Finland, Joensuu, Finland

collect data from a random sample of 326 farmers and six purposively selected lead farmers from six farming communities. Questionnaire and in-depth interviews were used for data collection. The data were analyzed using descriptive and inferential statistics. The study revealed a significant variation between locations and use of drought adaptation approaches. The study showed that the most common drought adaptation measures comprise locating farms on riverine areas, drought monitoring, formation of farm-based organizations for dissemination of climate information, application of agro-chemicals, changing planting dates, cultivating different crops, integrating crop and livestock production, changing the location of crops, diversifying from farm to non-farm income-generating activities, and cultivation of early maturing crops. Therefore, it was recommended, among other things, that Non-Governmental Organizations (NGOs) should assist the government to construct small-scale irrigation facilities and provide drought-resistant crops to further boost the capacity of farming communities in Ghana.

---

**Keywords**

Rural Communities · Subsistence Farmers · Drought · Adaptive Capacity

---

**Introduction**

Climate change has occurred and still occurring. Among all climate change-induced disasters, drought is the costliest and most devastating climatic disaster that imposes untold adverse consequences on human activities. Its recurrent occurrence is associated with high level of vulnerability among farming households (Makoka 2008; United Nations 2010). It severely affects agriculture in rural areas as well as trade and food security in both developed and developing economies of the world. Drought is particularly hazardous to communities which depend on agriculture for livelihood (Diaz et al. 2016). Incidence of drought is prevalent in Ghana, with the 1983 being the severest and most destructive in the history of the country (Owusu and Waylen 2009). Drought conditions impose consequences on crop yield and food security (Van de Giesen et al. 2010). Previous report indicated that persistent drought conditions affected all investments in the agricultural sector in the country. Unreliable rainfall, prolonged droughts, coupled with high temperatures have severely affected sustainable agriculture in the country (Armah et al. 2011; Dietz et al. 2013). Ajzen's (1985) theory of planned behavior argues that individuals perform certain planned actions known as behaviors in response to the achievement of a target. Given the serious problems posed by drought to agriculture in Ghana, farmers practice adaptation to overcome or reduce the resultant vulnerability.

Families whose livelihoods depend on farming activities need a variety of adaptation strategies to mitigate the harmful impacts of climate change and. This

will help them to maintain their livelihoods (Uddin et al. 2014). Adaptation serves as the means to mitigate a system's vulnerability to hazardous events. Adaptation reflects farmer's adaptive capacity. It is a process through which a society makes better adjustments and changes in order to adapt to an unforeseen situation in the future (Smit and Wandel 2006; United Nations Framework Convention on Climate Change (UNFCCC) 2011). Adaptation refers to the process of adjustment to the actual or expected climate, its variability, and concomitant effects (Intergovernmental Panel on Climate Change (IPCC) 2014; Quandt and Kimathi 2016). It is a means to build a system's capacity, resilience, and to adjust to the impact of climate change with the ultimate aim of reducing vulnerability. It is a process through which a society makes better adjustments and changes in order to cope with an unforeseen situation in the future (Smit and Wandel 2006). It may involve adjustments in technologies, lifestyles, infrastructure, ecosystem-based approaches, basic public health measures, and livelihood diversifications to reduce vulnerability (IPCC 2014). It may also serve as means to optimizing the potential benefits of climate change. Numerous studies have examined farmers' adaptation to climate change in different locations and contexts (Mabe et al. 2014; Obayelu et al. 2014; Shongwe et al. 2014). However, these studies are not only predominantly quantitative but also based broadly on farmers' adaptation to climate change. Farmers' adaptation to climate change is dependent upon specific climate change events and hence, may differ from one climatic event to another. The measures that farmers employ to adapt to other climate change events may differ from strategies employed to adapt to drought. Therefore, a clear understanding of farmers' adaptation to drought is desirable for designing and implementing appropriate drought adaptation strategies to enhance sustainable agriculture in Ghana. The study will expand theoretical knowledge and understanding of drought adaptation planning. Specifically, the study will shed more light on farmers' planned behavior towards drought. This will provide the necessary information and reference material for other researchers and drought management policy-makers. The study also explored only farmers' views on the use of both on-farms and off-farm measures to combat drought.

## Study Areas

Three agro-ecological locations, namely, Wa West (Savannah zone), Nkoranza North (Transitional zone), and Wassa East (Forest zone) of Ghana were chosen as the sites for this study (Fig. 1). Evidence indicates that rain-fed agriculture constitutes the main livelihood activity in the selected agro-ecological locations. For instance, crop farming (96.1%) is the major activity undertaken by households in the Wassa East District while most households (97.2%) in the Wa West District are engaged in crop farming as the main economic activity. Similarly, almost all agricultural households (98.5%) in the Nkoranza North District are involved in crop farming (Ghana Statistical Service 2013, 2014).

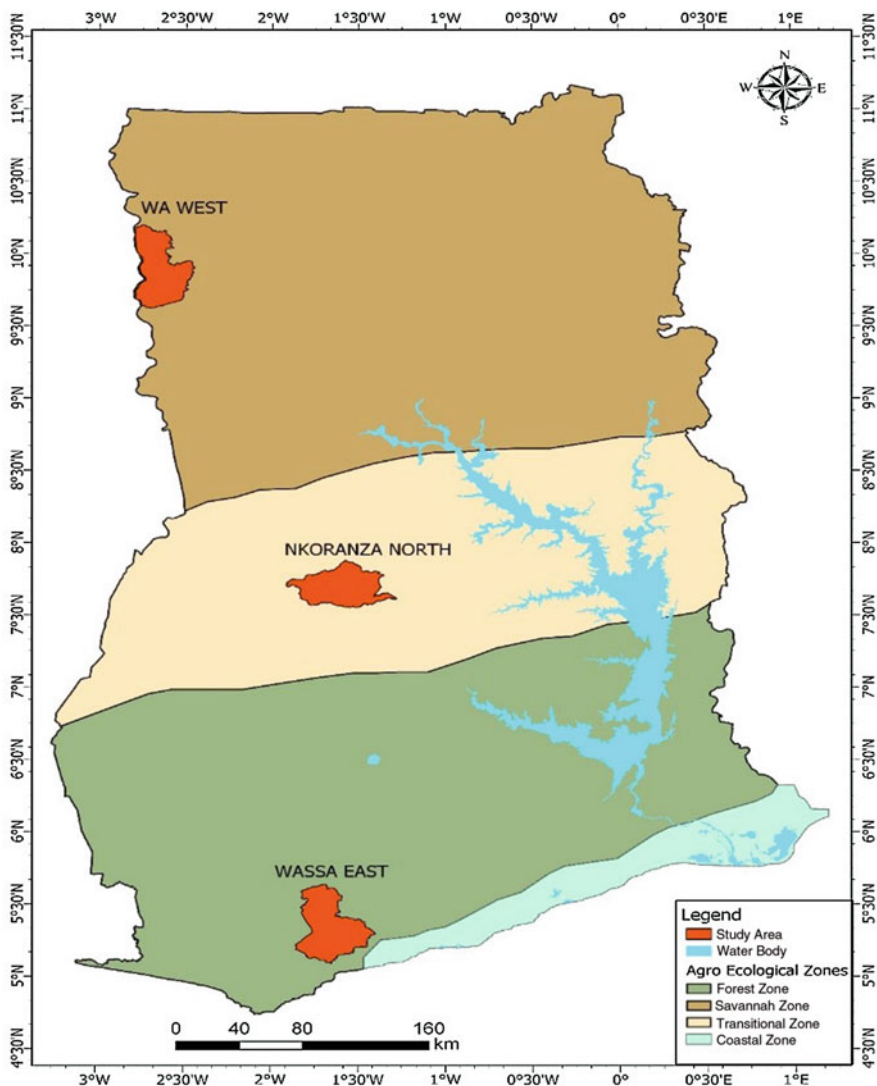


Fig. 1 Map of selected agro-ecological locations

### Data Collection and Sampling Procedure

The study employed cross-sectional survey design because it has some practical advantages over longitudinal and experimental designs. Cross-sectional design helps to capture large factual numeric and descriptive data from a large sample that represents a wide target population on a one-shot basis (Bhattacharjee 2012). Out of a total population of 1765 household farmers, 326 participants were randomly selected using Yamane’s (1967) formula. In generally, farming is a male-dominated

activity in Ghana (Food and Agriculture Organization (FAO) 2012). However, harvesting, processing, and marketing is usually done by the female. Traditionally, the head of each household in these study areas is a male. However, in the absence of a male head the de facto female heads or de jure household heads were interviewed (See, Danquah 2015). Both qualitative and quantitative data were collected using structured questionnaire and in-depth interview guide.

## Data Processing and Analysis

The first step in the process of analyzing qualitative data was data transcription. The tape recordings were listened to several times so as to get a complete sense of the data. All the transcribed data was categorized into patterns by following the guidelines prescribed by Miles and Huberman (1994) (cited in Cohen et al. 2011). Five points scale Likert estimation was used to assess or rate farmers' perception to sets of constraints to drought adaptation. The Likert scale ranging from "*Strongly Disagree (5)*" to "*Strongly Agree (1)*". We also employed Pearson Chi-Square Test Statistic Tool in the analyses. This helped to compare farmers' adaptation practices across the three selected agro-ecological zones. In addition, Phi and Crammer's V were generated as measures of contingency coefficient to explore the strength of the association between the agro-ecological zones and farmers' adaptation strategies (Prematunga 2012). Problem Confrontation Index (PCI) was used as modified procedure adopted from Elias (2015) and Talukder (2014), and was computed as follows:

$$PCI = [5(P_{SA}) + 4(P_A) + 3(P_N) + 2(P_D) + (P_{SD})]$$

Where:

$P_{SD}$  = Frequency of farmers who rated the problem as strongly disagree

$P_D$  = Frequency of farmers who rated the problem as disagree

$P_N$  = Frequency of farmers who rated the problem as not sure

$P_A$  = Frequency of farmers who rated the problem as agree

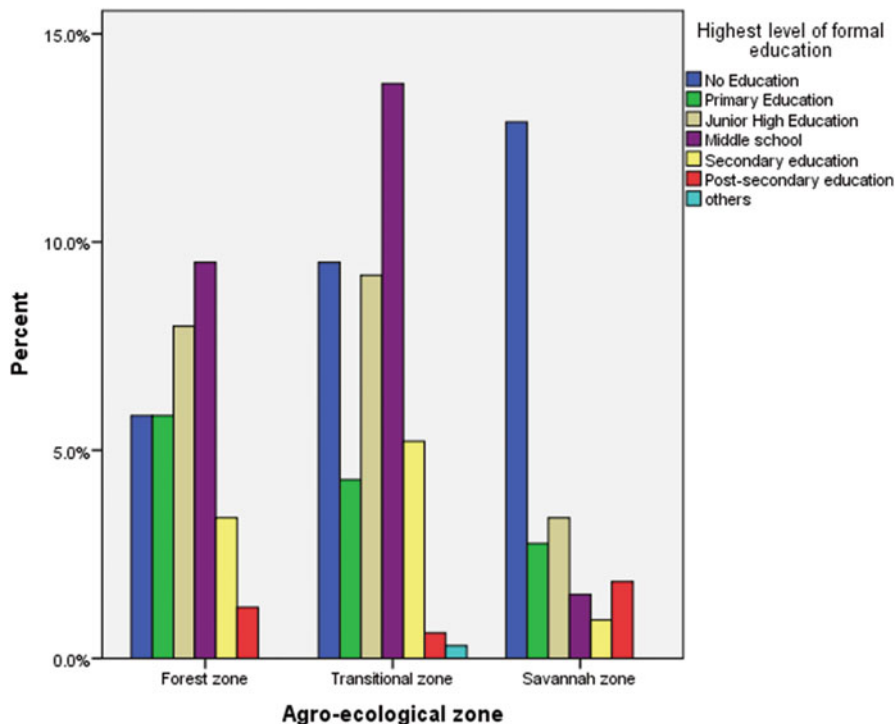
$P_{SA}$  = Frequency of farmers who rate the problem as strongly agree

---

## Results and Discussion

### Farm Household Characteristics and Adaptation Capacity

We asked participants to indicate their level of formal education, age, years of schooling, farming experience, farm size, landholding, household size, and dependents (Fig. 2). The proportion of farmers in the Forest agro-ecological zone who obtained middle school education (9.51%) is less than the proportion of farmers in Transitional agro-ecological zone with middle school education (13.80%). This



**Fig. 2** Farmers' level of education across agro-ecological zones

implies that most farmers in the Forest and Transitional zones had completed middle school compared to their farming counterparts in the Savannah zone where majority (12.88%) had no education.

The educational background of farmers presupposes that these farmers would have knowledge and understanding of climatic events as well as climate change adaptation. According to Apata, (2011), education among farmers can promote climate change adaptation. Similarly, other empirical evidence from a study conducted by Abdul-Razak and Kruse (2017) indicated that farmers with formal education had high adaptive capacity while farmers without formal education had low adaptive capacity to cope with climate change and variabilities

The minimum age of the farmers was 18 years while the maximum age was 87 years (Table 1). The mean age of the farmers was 43.9 years (Mean = 43.99, SD = 14.12). Similarly, the result as shown in Table 1 is indicative that the participants have been farming for almost 19 years (Mean = 18.96, SD = 13.45). Thus, the average farming experience is 18.96 years while the minimum and maximum years of farming experience are 1 year and 76 years, respectively. Farming experience contribute to the level of knowledge on climate change adaptation and risk management (Montle and Teweldemedhin 2014). It is also clear from the results that the selected farmers had an average of 6.83 acres (Mean = 6.83, SD = 6.80).



**Table 1** Descriptive statistics of farm household characteristics

Variable	<i>N</i>	Min	Max	Mean	SD
Age (in years)	326	18.00	87.00	43.99	14.12
Years of schooling	326	0.00	22.00	6.89	4.79
Farming experience (in years)	326	1.00	76.00	18.96	13.45
Farm size (in acres)	326	1.00	55.00	6.83	6.80
Landholding size (in acres)	326	2.00	250.00	13.77	16.66
Household size	326	1.00	25.00	6.37	3.56
Number of dependents	326	0.00	10.00	2.83	2.08

Moreover, farmers had 1.0 acre and 55.0 acres as minimum and maximum farm size, respectively. It was revealed that most of the farmers who had large farms cultivated both cash and food crops. For instance, most farmers in the Forest zone planted vast acres of cocoa whereas some farmers in the Transitional zone cultivated cashew plants on large scale. The results show that farmers' farm estate landholding ranged from at least 2.0 acres to a maximum of 250 acres, with average landholding of 13.77 acres. This implies that access to land to undertake agricultural activities may not constitute a problem to the rural farmers (see, e.g., Kassaga and Kotey 2001).

The minimum and maximum household size were 1 and 25 persons, respectively. The average household size was found to be six (Mean = 6.37, SD = 3.56) and the number of dependents in households ranged from zero to a maximum of 10. Households had about three dependents on the average (Mean = 2.83, SD = 2.08). Household size constitutes labor endowment of the farm household and it is an integration part of on-farm labor provision in smallholder farming systems (Deressa et al. 2009).

## Constraints to Drought Adaptation

Farmers may have knowledge and information on drought adaptation. However, these farmers may not be capable of adapting to drought because certain factors that can hinder their adaptation behavior (see, e.g., Ajzen 1987, 2006). The results highlight that there are several challenges that confront farmers. It is evident from the results shown in Table 2 that a majority of 261 farmers (85.3%) agreed that shortage of water for irrigation is problem that confronts their capacity to cope with the impacts of drought on their farming activities. The associated PCI indicates that shortage of water for irrigation ranks first among all the problems that farmers face. This situation can be attributed to the absence of major water sources coupled with reduced precipitation in the selected agro-ecological zones (Owusu and Waylen 2009). The shortage of water poses a challenge to farmers who would have otherwise wished to irrigate their farms during episodes of drought. This confirms results of a study by Abid et al. (2015) that shortage of water for irrigation is challenge that limits farmers adaptation to drought. Furthermore, the results indicate that out of the

**Table 2** Constraints to farmers adaptation to drought

	Strongly disagree		Disagree		Not sure		Agree		Strongly agree		Rank
	<i>n</i>	%	<i>N</i>	%	<i>n</i>	%	<i>N</i>	%	<i>n</i>	%	
Constraints to adaptation	15	4.6	30	9.2	3	0.9	162	49.7	116	35.6	1312
Shortage of water for irrigation	25	7.7	38	11.0	3	0.9	127	40.0	134	41.2	1288
Unavailability of financial resources	14	4.3	49	15.0	3	0.9	159	48.8	101	31.0	1262
High cost of agricultural inputs	30	9.2	107	32.8	7	2.1	127	39.0	55	16.9	1048
Inadequate labor force	16	4.9	143	43.9	7	2.1	112	34.4	48	14.7	1011
Inadequate knowledge	45	13.8	109	33.4	3	0.9	116	35.6	53	16.3	1001
Inadequate access to extension services	21	6.4	173	53.1	7	2.1	82	25.2	43	13.2	931
Inadequate time for planning	70	21.5	131	40.2	4	1.2	68	20.9	53	16.3	881
Inadequate access to weather information	82	25.2	138	42.3	4	1.2	67	20.6	35	10.7	813

NB: <sup>a</sup>Problem Confrontation Index (PCI)

326 respondents, a majority of 85.3% farmers agreed that unavailability of financial resources serve as a constraint to their effort to adapt to drought (Table 2). This was ranked as the 2nd problem that confronts their capacity to adapt to drought. Lack of finance has been cited as the common problem that considerably hampers most farmers from adopting improved varieties of seed to combat drought (Fisher et al. 2015; Pardoe et al. 2016). High cost of agricultural inputs was rated or ranked 3rd and Inadequate labor force 4th by the farm household heads within the three ecological zones the study was conducted. However, farmers were least concern about access to land for their farming activities. This was ranked 9th on the list of factors influencing farm household ability to adapt to drought in the study area. Invariable, it was expected that extension education and information to weather forecast should feature prominently on top of the ranking, but turned out otherwise. Lack of agriculture extension services and climate base information in the form of weather forecast have been cited as the policy constraints to adaptation strategies of smallholder farmer in the tropics, particularly in sub-Saharan Africa including Ghana (Naab et al. 2019).

## Determinants of Adoption of Drought Adaptation Measures

This section focuses on the presentation and discussion of main results on farmers' adoption or non-adoption of various drought adaptation measures. It also discusses farmers' socio-demographic factors as determinants of drought adaptation strategies. Table 3 presents the results with respect to farmers' drought adaptation across the three agro-ecological locations in Ghana. The application of agro-chemicals as a drought adaptation measure is significantly associated with agro-ecological locations as shown by the ( $\chi^2 = 43.98$ ; DF = 2,  $N = 326$ ),  $p < 0.001$ ). It is indicative from the results that majority of farmers (90.7%) in Nkoranza North in the Transitional zone applied agro-chemical compared to farmers in the Daboase and Wechaiu (54.5% and 63.2%, respectively) who adapted to drought through the application of agro-chemicals. Most crop farmers in Daboase in the Transitional zone adopted the application of agro-chemicals compared to other farmers in the Forest zone because the Forest oxisol soil has higher moisture holding capacity and fertility and therefore more capable of supporting crop production. On the whole, the study reveals that most farmers (72.1%) in the selected study areas adopted application of agro-chemicals as measure to adapt to drought. This finding is consistent with results of previous studies that applying both organic and inorganic fertilizer on farmlands is a method of mitigating low crop yield associated with unreliable rainfall pattern and prolonged dry spell (Kurothe et al. 2014; Kloos and Renaud 2014; Pardoe et al. 2016).

The results as shown in Table 3 indicate that majority of farmers in Daboase in the Forest zone do not resort to migration as a drought adaptation measure. Out of the 110 farmers in the Forest zone who participated in the survey, an overwhelming majority of 101 (91.8%) did not employ migration while only nine farmers (8.2%) resorted to migration as a measure to reduce their vulnerability to drought.

**Table 3** Adaptation measures across agro-ecological zones ( $N = 326$ )

Adaptation Measures	Agroecological Zones						Over all adoption	$\chi^2$	$p$ -value	Phi
	Forest( $n = 110$ )		Transitional ( $n = 140$ )		Savannah( $n = 76$ )					
	A (%)	NA (%)	A (%)	NA (%)	A (%)	NA (%)				
Application of agro-chemicals	60 (54.5)	50 (45.5)	127 (90.7)	13 (9.3)	48 (63.2)	28 (36.8)	235 (72.1)	43.98	0.001***	0.37
Changing planting time	52 (47.3)	58 (52.7)	119 (85.0)	21 (15.0)	63 (82.9)	13 (17.1)	234 (71.8)	49.33	0.001***	0.39
Migration	9 (8.2)	101 (91.8)	46 (32.9)	94 (67.1)	48 (63.2)	28 (36.8)	103 (31.6)	63.04	0.001***	0.44
Cultivation of different crops	44 (40.0)	60 (60.0)	16 (11.4)	124 (88.6)	5 (6.6)	71 (93.4)	261 (80.1)	42.58	0.001***	0.36
Changing location of crops	68 (61.8)	42 (38.2)	21 (15.0)	119 (85.0)	62 (81.6)	14 (18.4)	223 (68.4)	70.34	0.001***	0.47
Soil moisture conservation practices	12 (10.9)	98 (89.1)	47 (33.6)	93 (66.4)	28 (36.8)	48 (63.2)	87 (26.7)	21.39	0.001***	0.27
Cultivation of drought-tolerant crops	16 (14.5)	94 (85.5)	21 (15.0)	119 (85.5)	16 (21.1)	60 (78.1)	53 (16.3)	1.68	0.430 <sup>NS</sup>	0.07
Cultivation of early maturing crops	68 (61.8)	42 (38.2)	131 (93.6)	9 (6.4)	65 (85.5)	11 (14.5)	264 (81.0)	41.66	0.001***	0.36

Diversifying from farm to non-farm activities	48 (43.6)	62 (56.4)	69 (49.3)	71 (50.7)	45 (59.2)	31 (40.8)	165(50.6)	4.38	110 <sup>NS</sup>	0.10
Integrating crop with livestock production	53 (48.2)	57 (51.8)	84 (60.0)	56 (40.0)	47 (61.8)	29 (38.2)	184(56.4)	4.68	0.970 <sup>NS</sup>	0.12
Home gardening	50 (45.5)	60 (54.5)	48 (34.3)	92 (65.7)	32 (42.1)	44 (57.9)	130(39.9)	3.41	0.180 <sup>NS</sup>	0.10
Water harvesting practices	19 (17.3)	91 (82.7)	9(6.4)	131 (93.6)	19 (25.0)	57 (75.0)	47(14.4)	14.87	0.001 <sup>***</sup>	0.21
Changing size of farm land	84(60)	56(40)	41 (37.3)	69 (62.7)	36 (47.4)	40 (52.6)	161(49.4)	12.89	0.001 <sup>***</sup>	0.20
Drought monitoring	41 (37.3)	69 (62.7)	91 (70.0)	42 (30.0)	45 (59.2)	31 (40.8)	184(56.4)	27.15	0.001 <sup>***</sup>	0.30

NB: \* Implies significant, NS implies not significant at 0.05 (2-tailed), A Adopted, NA Not Adopted  
 $p < 0.05^*$ ,  $p < 0.01^{**}$ ,  $p < 0.001^{***}$

Moreover, out of the 140 farmers in Nkoranza North in the Transitional zone that participated in the study, it was found that a greater proportion of farmers (67.1%) did not adopt migration as drought adaptation measure. Thus, migration is not a common drought adaptation strategy in the Forest as well as the Transitional zones of Ghana. This contradicts findings of Yang et al. (2015) that migration is the commonest drought adaptation strategy among farmers in the Ningxia Hui Autonomous Region of North-western China. Most farmers in the Forest and Transitional zones of Ghana do not adapt to drought through migration because there are various livelihood options and crop diversification strategies that assist them to adapt to the hardships imposed by drought (Asante et al. 2017). For instance, various artisanal activities, trading or business ventures, seeking employment in craft and cottage industries, and other sources of off-farm income generating abound in the forest belt of Ghana and hence, most farmers in this area do not over dependent on rain-fed agriculture. However, there are more cases of migration among farmers in Wechaiu in the Transitional zone compared to farmers in Daboase in the Forest zone (see Derbile et al. 2016). This is because some farmers in the Forest zone migrated either from the Savannah zone, Transitional zone, or neighboring communities in Cote d'Ivoire to undertake cocoa cultivation since the rainfall pattern in the Forest is more favorable to farming activities (Jarawura 2013).

The results suggest that farmers in the Savannah zone are more likely to adapt to drought and rainfall variability through migration to other places compared to farmers in the Forest and Transitional zones of Ghana. This collaborate the findings Van der Geest (2011) and Jarawura (2013), that rainfall variability and climate change slightly account for the out-migration of farmers from the three northern regions to Brong Regions of Ghana. When there are drought conditions some farmers migrate to other areas to engage in other livelihood activities. There is a statistical highly significant relationship between agro-ecological zones and farmers' adoption of migration as a drought adaptation measure ( $\chi^2 = 63$ ; DF = 2;  $N = 326$ ;  $p < 0.001$ ).

Migration among farmers is dependent on agro-ecological location. The phi value (0.44) indicates that is a positive significant moderate difference between farmers' migration patterns and agro-ecological zones. This is because the severity of drought differs from one agro-ecological zone to another (Adepetu and Berthe 2007).

The results indicated that out of the 110 farmers interviewed in Daboase in the Forest zone, 89.1% were nonadopters of soil moisture conservation practices as an adaptation strategy. However, relatively small proportion of the farmers (10.9%) in this zone adopted soil conservation practices. Similarly, nonadopters were 66.4% and 63.2% in Transitional and Savannah zones respectively. Collectively, across all the ecological zones studied out of 326 farmers interviewed only 87 farmers employed soil conservation measures. This represents a total of 26.7% farmers.

Moreover, it was revealed that only 53 (16.3%) out of the 326 farmers in the three agro-ecological zones cultivated some sort of drought-tolerant crops as drought adaptation measure. The results show that most farmers in the agro-ecological location do not cultivate crops that are drought-resistant. Only a small proportion of farmers in the various agro-ecological zones indicated that they cultivated some

crops that are resistant to drought conditions. Farmers non-adoption of drought-resistant crop varieties can be attributed to the fact that most farmers in Ghana do not have access to drought-tolerant crops. This contradicts the results of previous works by Udmale et al. (2014) that rural farmers widely cultivate less water intensive and drought tolerant crops as adaptation options to drought.

The results show that a majority of 264 farmers (81.0%) out of the 326 farmers in the three agro-ecological zones adopted the cultivation of early maturing crops as a measure to adapt to drought. The adoption of early maturing crops is highly dependent upon agro-ecological zone. Most farmers in the Savannah and Transitional zones cultivate early maturing crops compared to the proportion of farmers in the Forest zone who cultivate early maturing. The results of this current study corroborate the findings of various previous studies (Bawakyillenuo et al. 2016; Pardoe et al. 2016) that farmers resort to the cultivation of early maturing crops as a climate change adaptation strategy.

The study also revealed that farmers have been adapting to drought by integrating both farming and non-farming activities as similarly found by a previous study by Balama et al. (2013). From the results out of the 326 farmers, a little over half (50.6%) diversified from farm to non-farm income generating activities in order to adapt to the impact of drought. Majority of farmers (59.2%) who diversified farm to non-farm income generating activities were located in Wechaiu in the Savannah zone.

The study further indicated that most farmers (56.4%) integrated livestock production with crop production as drought adaptation measure. This is because farmers seek solace in livestock rearing when their crops fail as a result of drought. Farmers do experience decline in crop productivity as a result of drought. Therefore, they have seen the need to engage in livestock rearing to augment their farming activities. Similarly, Balama et al. (2013) has found that local farmers in Kilombero District of Tanzania integrated crop farming into livestock production as a climate change adaptation strategy. The results in Table 3 indicate that most farmers in Wechaiu in the Savannah zone (61.8%) as well as those in the Transitional zones (60.0%) integrated livestock rearing with crop production compared to farmers in the Forest zone (48.2). This confirms results of a study by Bawakyillenuo et al. (2016) that integrating livestock rearing into crop production is common climate change adaptation method being adopted by farmers in rural Savannah zone of northern Ghana. This is because the vegetation and climatic features within the Savannah and Transitional zones are more favorable to livestock rearing compared to the Forest zone. However, this is not significant ( $\chi^2 = 4.68$ ; DF = 2,  $N = 326$ ;  $p > 0.05$ ).

There is moderate significant association between the proportion of farmers who employed water harvesting practices and agro-ecological zone ( $\chi^2 = 14.87$ ; DF = 2;  $N = 326$ ,  $p < 0.001$ ). A majority of farmers (93.6%) in the Transitional zone and farmers in Savannah (75.0%) employed water harvesting practices as drought adaption measure compared to number of farmers in the Forest zone (82.7%) who did not employ water harvesting practices to combat drought. Most farmers in the Savannah and Transitional zones experienced severe drought conditions and acute

water shortage than farmers in the Forest zone (Armah et al. 2011). This in keeping with the fact that farmers in the Savannah and Transitional zones need to harvest rainwater and store it for domestic use and animal consumption as well. However, farmers in the Forest may have unimpeded access to riverine water supply throughout the year due to high level of precipitation (Armah et al. 2011).

The results show strong relationship between change in farm sizes and agro-ecological zones ( $\chi^2 = 12.89$ ;  $DF = 2$ ;  $N = 326$ ,  $p < 0.001$ ). Variation in farm size as a drought adaptation strategy is dependent upon agro-ecological location. The proportion of farmers who change their farm sizes as drought adaptation mechanism varies across the agro-ecological zones (sensu, Hansen et al. 2004). The settler farmers in the Transitional zone have fixed portions of land for farming, whereas the native farmers have most of their land occupied by cashew plantation. Hence, such farmers may find it difficult to increase their farm size. Farmers in the Savannah zone may not even change their farm sizes because fertile lands are limited in supply. Hence, farmers are fixated to the same parcel of land. Moreover, the farmers may find it unrewarding and time-consuming to clear new parcel of land for cultivation in the midst of unpredictable and scanty rainfalls. However, majority of farmers 84 (60.0%) in Daboase in the Forest zone stated that they changed their farm sizes in order to deal with the impacts of drought. Finally, the results indicate that out of the 140 farmers in Nkoranza North in the Transitional zone, 70.0% in this zone adopted drought monitoring as drought adaptation strategy, particularly constant listen to weather news on radio and TV stations on daily basis. During an interview in the Transitional zone, a male farmer indicated that:

*I always listen to 'weather man' on FM radio in order to know the on-set of rains before I even begin to prepare for farming. Sometimes before I go to farm, I have to listen to 'weather man' to know whether it would rain on that day or not (Male farmer, Transitional zone).*

Similarly, a majority of 45 farmers (59.2%) in the Savannah zone indicated that they employed drought monitoring as a tool for preparing for impending drought conditions and to improve their resilience to drought vulnerability. The plurality of radio stations as well as the availability of agricultural extension officers in the study areas provide easy access to weather information. Hence, most farmers continually monitor weather and climatic conditions before they plant their crops. Regarding drought monitoring, a lead farmer in the Savannah zone hinted during an interview schedule that:

*We do not sow arbitrarily in this area. We usually 'study' the weather pattern to predict the arrival of rains before sowing seeds (Male lead farmer, Savannah zone).*

However, majority of 69 farmers, representing 62.7% of the 110 farmers who participated in the survey in the Forest zone did not practice drought monitoring. The climatic conditions in this zone is quite conducive for agriculture. The farmers in this zone hardly experience severe drought that lasts long as compared



to farmers in the Savannah and Transitional zones. Moreover, the soil in the Forest zone holds moisture. Hence, farmers in this zone do not really have to monitor the rainfall pattern as farmers in the Savannah and Transitional zones would do. Overall, more than half of farmers (56.4%) practice drought monitoring. This shows that drought monitoring is mostly being practiced by farmers as a method of adapting to drought in the selected agro-ecological zones. This confirms the results of a study by Pardoe et al. (2016) that farmers “follow the rain” until they are well-convinced that the rain would not fail them before they sow their seeds. It is obvious that drought monitoring is highly statistically and significantly related to agro-ecological zones ( $\chi^2 = 27.15$ ; DF = 2,  $N = 326$ ;  $p < 0.001$ ). This is because various agro-ecological zones have different amount of precipitation and soil moisture content to support farming activities. The phi value (0.30) indicates that there is a moderate significant relationship between drought monitoring and agro-ecological zones. Therefore, the decision of a farmer to monitor and time drought would depend upon a particular zone where he is located. Rather than employing only scientific and orthodox strategies to adapt to drought, the study also revealed that the farmers also employ prayers and supplications as means to adapt to drought conditions. They offer supplications to Him so that He would cause the rain to fall. This could be so because farmers have sociocultural perception about climate change and drought. Some farmers attribute the occurrence of climate and drought to the intention of God and other deities (Jarawura 2013). Hence, farmers combine both spiritual and scientific means to adapt to drought.

*Traditionally, we usually call on deities to intercede for us to get the rains. We go round the community to pour libation asking the gods of the land to cause rains to fall. And if it rains, we thank them [gods] by making animal sacrifice. (Male farmer, savannah zone). During droughts, we throw a challenge to the gods of the land to let it rain to prove that they are living gods (Male farmer, Transitional zone).*

In conclusion, farmers employed both scientific and unscientific methods to adapt to drought in the selected agro-ecological locations in Ghana. The study reveals that drought adaption measures differ significantly among farmers in the Forest, Transitional and Savannah zones of Ghana. This finding is in harmony with results of various studies (Jarawura 2014; Abid et al. 2015; Bawakyillenuo et al. 2016) that climate and drought adaptation strategies are numerous and their implementation differs from place to place. This is because farmers' knowledge of drought adaption and their adaptive capacities as well as rainfall and soil properties differ from place to place. Therefore, farmers in various geographical locations would adapt to drought by adopting different mechanisms. However, the most commonly adopted drought adaptation measures comprise application of agro-chemicals, changing of planting date, cultivating different crops, integration of crop and livestock production, changing the location of crop on yearly basis, diversifying from farm to non-farm income generation activities, cultivation of early maturing crops, and drought monitoring.

## Conclusions

Farmers' adaptation to drought differs across various agro-ecological locations in Ghana and they adapt to drought by employing mixed adaptation strategies. The most commonly used drought adaptation strategies include application of agro-chemicals, changing planting dates, cultivation of different crops, changing location of crops, cultivation of early maturing crops, diversification to non-farm activities, integrating crops and livestock production, as well as drought monitoring. Moreover, farmers' choice of specific drought adaptation strategies is a determinant of various factors. Farmers' ecological location acts as the major significant determinant of their adoption of all the eight drought adaptation measures. Finally, farmers with access to credit facilities and extension services are more likely to adopt farm-based drought adaptation measures and less likely to diversify to non-farming activities. Ministry of Food Agriculture (MoFA) and the National Disaster Management Organization should provide drought relief measures and safety net programs for vulnerable smallholder farmers. This also calls for the introduction and implementation of crop insurance schemes where farmers would be given the opportunity to indemnify their crops against possible loss associated with drought. As a matter of mitigating farmers' vulnerability to drought, both governmental organizations such as MoFA and National Climate Research Institute, and other non-governmental organizations should help develop, introduce, and implement affordable drought adaptation technologies in farming communities. The introduction and cultivation of drought-resistant crops, water harvesting, and conservative agriculture practices should be promoted among farmers in the country.

---

## References

- Abdul-Razak M, Kruse S (2017) The adaptive capacity of smallholder farmers to climate change in the northern region of Ghana. *Clim Risk Manag* 17:104–122
- Abid M, Scheffran J, Schneider UA, Ashfaq M (2015) Farmers' perceptions of and adaptation strategies to climate change and their determinants: the case of Punjab province, Pakistan. *Earth Syst Dyn* 6:225–243
- Adepetu AA, Berthe A (2007) Vulnerability of rural sahelian households to drought: options for adaptation. A final report submitted to assessments of impacts and adaptations to climate change (AIACC), Project No. AF 92. Retrieved from [http://www.start.org/Projects/AIACC\\_Project/Final\\_Reports/Final](http://www.start.org/Projects/AIACC_Project/Final_Reports/Final)
- Ajzen I (1985) From intentions to actions: a theory of planned behaviour. In: Kuhl J, Beckmann J (eds) *Action-control: from cognition to behaviour*. Springer, Heidelberg, pp 11–39
- Ajzen I (1987) Attitudes, traits, and actions: dispositional prediction of behaviour in personality and social psychology. In: Berkowitz L (ed) *Advances in experimental social psychology*. Academic, New York, pp 1–63
- Ajzen I (2006) Theory of planned behaviour. Retrieved from <http://people.umass.edu/~ajzen/tpb.diag.html#null-link>
- Apata TG (2011) Factors influencing the perception and choice of adaptation measures to climate change among farmers in Nigeria. Evidence from farm households in Southwest Nigeria. *Environ Econ* 2(4):74–83

- Armah FA, Odoi JO, Yengoh GT, Obiri S, Yawson DO, Afrifa EKA (2011) Food security and climate change in drought-sensitive savannah zones of Ghana. *Mitig Adapt Strateg Glob Chang* 16(3):291–306
- Asante WA, Acheampong E, Kyereh E, Kyereh B (2017) Farmers' perspectives on climate change manifestations in smallholder cocoa farms and shifts in cropping systems in the forest-savannah transitional zone of Ghana. *Land Use Policy* 66:374–381
- Balama C, Augustino S, Eriksen S, Makonda FSB, Amanzi N (2013) Climate change adaptation strategies by local farmers in Kilombero District, Tanzania. *Ethiop J Environ Stud Manag* 6 (6):724–736
- Bawakyillenuo S, Yaro JA, Teye J (2016) Exploring the autonomous adaptation strategies to climate change and climate variability in selected villages in the rural northern savannah zone of Ghana. *Local Environ* 21(3):361–382
- Bhattacharjee A (2012) *Social science research: principles, methods, and practices*. University of South Florida, Tampa
- Cohen L, Manion L, Morrison K (2011) *Research methods in education*, 6th edn. Routledge, New York
- Danquah JA (2015) Analysis of factors influencing farmers' voluntary participation in reforestation programmes in Ghana. For Trees Livelihoods. <https://doi.org/10.1080/14728028.2015.1025862>
- Derbile EK, Jarawura FX, Dombo MY (2016) Climate change, local knowledge and climate change adaptation in Ghana. In: Yaro J, Hesselberg J (eds) *Adaptation to climate change and variability in rural West Africa*. Springer, Cham. [https://doi.org/10.1007/978-3-319-31499-0\\_6](https://doi.org/10.1007/978-3-319-31499-0_6)
- Deressa TT, Hassan RM, Ringer C, Alemu T, Yesuf M (2009) Determinants of farmers' choice of adaptation methods to climate change in the Nile Basin of Ethiopia. *Glob Environ Chang* 19 (2):248–255
- Diaz HM, Hurlbert M, Warren J (2016) Final research report of the rural communities' adaptation to drought. Canadian Plains Research Center, Regina. <http://www.parc.ca/vacea/assets/PDF/rcadrep.pdf>
- Dietz T, van der Geest K, Obeng F (2013) Local perceptions of development and change in Northern Ghana. In: Yaro J (ed) *Rural development in Northern Ghana*. Nova Science Publishers, New York, pp 17–36
- Elias AZM (2015) Farmers' problem confrontation in crop diversification at southern region of Bangladesh. *J Agroecol Nat Resour Manag* 2(3):230–233
- Fisher M, Abate T, Lunduka RW, Asnake W, Alemayehu Y, Madulu RB (2015) Drought tolerant maize for farmer adaptation to drought in sub-Saharan Africa: determinants of adoption in eastern and southern Africa. *Climate Change* 133(2):283–299
- Food and Agricultural Organization (2012) Gender inequalities in rural employment in Ghana: an overview. Retrieved from <http://www.fao.org/docrep/016/ap090e.pdf>
- Ghana Statistical Service (2013) Ghana living standard survey. Ghana Statistical Service, Accra
- Ghana Statistical Service (2014) 2010 population and housing census: district analytical report. Nkoranza North. Ghana Statistical Service, Accra
- Hansen J, Marx S, Weber E (2004) The role of climate perceptions, expectations, and forecasts in farmer decision making: The Argentine Pampas and South Florida. Final Report of an IRI Seed Grant Project. International Research Institute for Climate Prediction (IRI), The Earth Institute at Columbia University
- Intergovernmental Panel on Climate Change (IPCC) (2014) *Climate change 2014: impacts, adaptation, and vulnerability. Part B: regional aspects. Contribution of working group II to the fifth assessment report of the Intergovernmental Panel on Climate Change*. Cambridge University Press, Cambridge
- Jarawura FX (2013) Drought and migration in northern Ghana. Doctoral thesis, University of Ghana, Legon
- Jarawura FX (2014) Perceptions of drought among rural farmers in the Savelugu district in the northern Savannah of Ghana. *Ghana J Geogr* 6:102–120
- Kassaga K, Kotey NA (2001) *Land management in Ghana: building on traditional and modernity*. International Institute for Environment and Development, London

- Kloos J, Renaud FG (2014) Organic cotton production as an adaptation option in north west Benin. *Outlook Agric* 43(2):91–100
- Kurothe RS, Kumar G, Singh R (2014) Effect of tillage and cropping systems on runoff, soil loss and crop yields under semiarid rain fed agriculture in India. *Soil Tillage Res* 140:126–134
- Mabe FN, Sienso G, Donkoh S (2014) Determinants of choice of climate change adaptation strategies in northern Ghana. *Res Appl Econ* 6(4):75–94
- Makoka D (2008) The impact of drought on household vulnerability: the case of rural Malawi. Paper presented at the 2008 United Nations University (UNU-EHS) Summer Academy on Environmental Change, Migration and Social Vulnerability. Retrieved from <http://mpr.ub.uni-muenchen.de/15399>
- Miles MB, Huberman AM (1994) *An expanded source book: qualitative data analysis*, 2nd edn. Sage, London
- Montle BP, Teweldemedhin MY (2014) Assessment of farmers' perceptions and the economic impact of climate change in Namibia: case study on small-scale irrigation farmers (SSIFs) of Ndonga Linena Irrigation Project. *J Dev Agric Econ* 6:443–454
- Naab FZ, Abubakarib Z, Ahmed A (2019) The role of climate services in agricultural productivity in Ghana: the perspectives of farmers and institutions. *Clim Serv* 13:24–32
- Obayelu OA, Adepoju AO, Idowu T (2014) Factors influencing farmers' choices of adaptation to climate change in Ekiti state, Nigeria. *J Agric Environ Int Dev* 108(1):3–16
- Owusu K, Waylen P (2009) Trends in spatio-temporal variability in annual rainfall in Ghana (1951–2000). *Weather* 64(5):115–120
- Pardoe J, Kloos J, Assogba NP (2016) Seasonal variability: impacts, adaptations and the sustainability challenge. In: Yaro JA, Hesselberg J (eds) *Adaptation to climate change and variability in rural West Africa*. Springer International Publishing, Cham, pp 41–57
- Prematunga RK (2012) Correlational analysis. *Aust Crit Care* 25:195–199
- Quandt A, Kimathi YA (2016) Adapting livelihoods to floods and droughts in arid Kenya: local perspectives and insights. *Afr J Rural Dev* 1(1):51–60
- Shongwe P, Masuku MB, Manyatsi AB (2014) Factors influencing the choice of climate change adaptation strategies by households: a case of Mpolonjeni Area Development Programme (ADP) in Swaziland. *J Agric Stud* 2(1):86–98
- Smit B, Wandel J (2006) Adaptation, adaptive capacity and vulnerability. *Glob Environ Chang* 16:282–292
- Talukder Md R (2014) Food security assessment in Sylhet Haor area emphasizing homestead productivity and agricultural resource utilization. A thesis submitted to Bangabandhu Sheikh Mujibur Rahman Agricultural University in partial fulfillment of the requirement for the degree of Master of Science in agronomy. Sheikh Mujibur Rahman Agricultural University, Bangladesh
- Uddin MN, Bokelmann W, Entsminger JS (2014) Factors affecting farmers' adaptation strategies to environmental degradation and climate change effects: a farm level study in Bangladesh. *Climate* 2:223–241
- Udmale P, Ichikawa Y, Manandhar S, Shidaira H, Kiem AS (2014) Farmers' perception of drought impacts, local adaptation and administrative mitigation measures in Maharashtra State, India. *Int J Disaster Risk Reduct* 10:250–269
- United Nations (2010) *Natural hazards, unnatural disasters: the economics of effective prevention*. World Bank, Washington, DC
- United Nations Framework Convention on Climate Change (UNFCCC) (2011) *Assessing climate change impacts and vulnerability: making informed adaptation decisions*. Retrieved from [www.unfccc.int/adaptation](http://www.unfccc.int/adaptation)
- Van de Giesen K, Liebe J, Jung G (2010) Adapting to climate change in the Volta Basin, West Africa. *Curr Sci* 98(8):1033–1037
- Van der Geest K (2011) *The Dagara farmer at home and away. Migration, environment and development in Ghana*. PhD dissertation, University of Amsterdam. African Studies Centre, Leiden
- Yamane T (1967) *Statistics: an introductory analysis*, 2nd edn. Harper and Row, New York
- Yang J, Tan C, Wang S, Wang S, Yang Y, Chen H (2015) Drought adaptation in the Ningxia Hui Autonomous Region, China: actions, planning, pathways and barriers. *Sustainability* 7:15029–15056

**Open Access** This chapter is licensed under the terms of the Creative Commons Attribution 4.0 International License (<http://creativecommons.org/licenses/by/4.0/>), which permits use, sharing, adaptation, distribution and reproduction in any medium or format, as long as you give appropriate credit to the original author(s) and the source, provide a link to the Creative Commons license and indicate if changes were made.

The images or other third party material in this chapter are included in the chapter's Creative Commons license, unless indicated otherwise in a credit line to the material. If material is not included in the chapter's Creative Commons license and your intended use is not permitted by statutory regulation or exceeds the permitted use, you will need to obtain permission directly from the copyright holder.





# Smart Climate Resilient and Efficient Integrated Waste to Clean Energy System in a Developing Country: Industry 4.0

# 53

Anthony Njuguna Matheri, Belaid Mohamed, and Jane Catherine Ngila

## Contents

Introduction .....	1054
Paris Agreement on Climate Change .....	1055
Climate-Land-Water-Energy-Food Nexus .....	1056
Energy Security and Pursuit of Water, Food, and Earth System Resilience .....	1058
Water Security and Pursuit of Energy, Food, and Earth System Resilience .....	1061
Food Security and Pursuit of Water, Energy, and Earth System Resilience .....	1062
Biophysical and Biogeochemical Land-Climate Systems .....	1063
Nexus Contributions to Job Market .....	1064
Carbon Tax .....	1064
Data-Driven Nexus .....	1065
Industry 4.0 in Nexus and Climate Resilient .....	1065
Modelling of the Water-Energy-Food-Land-Climate Nexus .....	1066
Adaptation of Climate Change Technology Transfer in Developing Countries .....	1068
Nexus and Research Gap .....	1069
Analytics Framework .....	1069
Nexus Securities and Environmental Protection .....	1072
Policy and Governance (Coordination and Collaboration) for Climate Change .....	1073

This chapter was previously published non-open access with exclusive rights reserved by the Publisher. It has been changed retrospectively to open access under a CC BY 4.0 license and the copyright holder is “The Author(s)”. For further details, please see the license information at the end of the chapter.

A. N. Matheri (✉) · B. Mohamed

Department of Chemical Engineering, University of Johannesburg, Johannesburg, South Africa  
e-mail: [mbelaid@uj.ac.za](mailto:mbelaid@uj.ac.za)

J. C. Ngila

Department of Chemical Science, University of Johannesburg, Johannesburg, South Africa

Academic Affair, Riara University, Nairobi, Kenya

e-mail: [jcngila@riarauniversity.ac.ke](mailto:jcngila@riarauniversity.ac.ke)

© The Author(s) 2021

W. Leal Filho et al. (eds.), *African Handbook of Climate Change Adaptation*,  
[https://doi.org/10.1007/978-3-030-45106-6\\_69](https://doi.org/10.1007/978-3-030-45106-6_69)

1053

Equity, Climate Change, and Environmental Justice .....	1074
Conclusion and Recommendations .....	1076
References .....	1077

## Abstract

Climate change impacts a natural and human system on the entire globe. Climate-related extreme weather such as drought, floods, and heat waves alters the ecosystems that society depends on. Climate, land, energy, and water systems (CLEWS) are a critical aspect of high importance on resource availability, distribution, and interconnection. The nexus provides a set of guidelines to South Africa that aims on creating a level playing field for all sectors while achieving the aims of the SDGs that are cross-sectoral and multilevel approaches to climate change. The nexus expressed three domains that included resources, governance, and security. It integrated a smart climate resilient with inclusion of the governance and involvement of the stakeholders. Recognition of spatial and sector interdependencies should inform policies, investment and institutional for enhancing nexus security and climate change towards making transition green carbon deals. The nexus offers an integrated approach that analyzes the trade-offs and synergies between the different sectors in order to maximize the efficiency of using the resources that adapt institutional and optimum policy arrangements. Economic transformation and creation of employment through green economy is one of the COP26 green deal agendas in curbing the carbon emissions (green house emission, industrial processes, fuel combustion, and fugitive emissions) as mitigation to climate change, which is cost-effective and economically efficient. The future climate change policy in the developing countries is likely to be both promoted by climate technology transfer and public-private cooperation (cross-sector partnership) through the technology mechanism of the nexus and inclusion of the gender.

## Keywords

Adaptation · CLEWS · Climate change · Climate technology · Ecosystem · Green economy · Policy · Resilience · SDGs · Nexus

## Introduction

Green revolution, disruption of the natural resources and social-economic impact are becoming increasingly in Industry 4.0 (Fourth Industrial Revolution-4IR). The is due to enhancement of the adaptive capacity for the complex global challenges in advanced nexus approach to the sustainable management of climate change, land use, water, energy, and food. This serve the paradigmatically that was isolated and understanding of the interrelation of the WEF, human well-being, resilient ecosystem, climate change that coexists within the planetary boundaries. The shift in society disruption legion of unfortunate solution to an environment or development

challenges that end up creating new, unforeseen problems and dilemma (Newell et al. 2019; Matheri et al. 2020). The nexus describes the interconnections and interdependencies between the land, water, energy, and food (LWEF) sectors. These interdependencies of the LWEF securities have received growing attention in the past years by researchers and policy-makers. Lack of understanding of the nexus has been described as a major global economic challenge by the World Economic Forum. This put forward the nexus approach as a fundamental shift for sustainable development (Hassan et al. 2018). A review on the LWEF and land utilization needs to be addressed on policy-making and decision-making concerning the nexus framework and climate change. This bridges the gap between science and policy in the implementation of nexus. More importantly, the nexus can also support achieving the United Nations Sustainable Development Goals (SDGs), 2030 Agenda, because of its close relation to three SDGs: SDG2 “zero hunger,” SDG6 “clean water and sanitation for all,” SDG7 “affordable and clean energy,” and SDG13 “climate action” (Tashtoush et al. 2012).

The nexus is expressed into three domains that include resources, governance, and security. The domain requires inclusion of the policy and institution expertise, natural resources use, environmental science, and engineering expertise for the mutual perspective of multiple decision-making, solution, and resource recovery (Scott et al. 2015, 2018). The priorities areas for climate change include decarbonization of the economy, digitization, decentralization of the production, transition of 100% renewable energy, carbon taxation (tax the polluters not people), access to sustainable finance, assist small island and least developing countries, support people affected by climate change, increase accessibility and availability of the jobs and livelihood, nature-based solutions, stronger commitments by the major emitters, and commitments to achieve carbon neutrality by 2050 (United Nation (UN) 2020). The focus is placed on implementation of the nexus concepts with a smart climate resilient on nexus regional dialogue programs by United Nations (UN) bodies, World Bank, GIZ, European Union (EU), Africa Union (AU), Middle East and North Africa (MENA), and World Economic Forum among others.

## Paris Agreement on Climate Change

Climate change results in disruption of national economies that affect the countries, communities, living standards, and flora and fauna. With likely shift of the climate zones, long-term, changes of the rainfall patterns, and raising of the temperature, climate change shock is expected to increase frequency putting pressure in energy, food, water supply, and competition of land ownership in unaffected areas (Stocker et al. 2013; Carter and Gulati 2014). The historic Paris agreement provides countries with strong global climate change response by keeping the temperature rise below 2–1.5 °C. It encourages parties and stakeholders to reduce the impacts of the climate change (ambition and implementation to ensure highest mitigation and adaptation efforts by all parties with building climate resilience).



The intergovernmental climate change panels have recorded the following:

- 1901–2010: Warm oceans and diminishing snows and ice by 1.07 million km<sup>2</sup> with rise of the sea levels by 19 cm
- 1880–2012: Increase of the temperature by 0.85 °C due to warmer climate
- 1990 to date: Global emission of the CO<sub>2</sub> that has increased by 50%

The agreement solidifies international cooperation on investment of a low-emission economy (green economy) that contains transparency framework, mutual trust, and confidence. Industry 4.0 is overseeing the scalable, affordable solutions that are more resilient to the economy and mostly helping the developing countries toward the low-carbon economy. Major technologies and institutions will see a shift of containing and ensuring that global warming does not exceed the threshold. SDG 13 defines the commitment by strengthening resilience and adaptive capacity; integrating climate change strategies, policies, and planning; creating awareness on adaptation, mitigation, and impact reduction; and implementing meaningful mitigation again and transparency through UNFCCC (United Nation Framework Convention on Climate Change) framework and inclusion of the marginalized communities and planning and management (SDGs, UN 2019). The impact of the climate change will be amplified through interdependence and interconnection among the resources, land, water, energy, and food.

---

## Climate-Land-Water-Energy-Food Nexus

The global web of mutual interlinkages defines the climate-land-water-energy-food nexus on societal changes that drive growth and demand. The ongoing disruption of the environment is likely to alter the accessibility or availability of land, energy, water, and food that is central to climate change policies and natural resource management (Markantonis et al. 2019). Holistic and integrated approaches to resource planning and management have been largely embraced by decision-makers and stakeholders although the benefits of the nexus approach may appear obvious to its advocates. The nexus is related to integrated management, consumption, economic resources, policy, security, and approach. The nexus concept needs to be approached beyond the research and development domain.

The WEF nexus has emerged as a useful disruption in Industry 4.0 in understanding multiple interdependencies that coexist between land use, water, energy, food, and climate change. It is a multidisciplinary that cuts across both state and non-state sectors. The WEF has potential to unlock groundbreaking solutions to complex problems with appropriate models and climate change mitigation. The is expressed as National Development Plans (NDP) and United Nations Sustainable Development Goals (SDG) that are emerging in the international agenda at the World Economic Forum on understanding the link between use of resources in providing universal basic rights and climate protection (Seeliger et al. 2018). This was welcomed by the Conference of Parties (COP) by the UNFCCC on



**Fig. 1** The water-energy-food nexus concept. Source: IW: LEARN, Germany 2014

enhancement of climate technologies' development and knowledge transfer through the technology mechanisms of greater public-private cooperation (cross-sector partnerships). This is through the action on climate and SDGs, climate technology, education, youth, gender, having open-source information and intellectual properties, climate finance, adaptation and resilience, and capacity building (Forsyth 2007; Forsyth 2005; COP25 2019a, b). Figure 1 shows the WEF nexus concept.

The nexus can provide technology, innovation, and analytical framework by complementing design principles and new policy perspectives for the CLEWS' security policy. Building future planned actions on nexus needs advanced research and development (R&D) such as cost action and Horizon 2020. The role of the WEF nexus is gaining increasing attention in the region from developing countries, which is a partner in the Nexus Regional Dialogues Programme (NRDP) with an aim to create an enabling environment that drives implementation and cross-sectoral engagement of nexus investment projects. The intention is to provide decision-makers with prospects where the theory of the nexus concept has been made operational.

The C40 cities program seeks to build and identify opportunities and build evidence benefits of climate action synergies within the climate, water, and energy nexus. C40 cities have built a platform of networks, adaptation, communications, finance, and other programs on taking bold climate actions that are healthier and more sustainable to resilient cities (C40 2020).

Specific to Agenda 2030, 4 of the 17 SDGs are directly related to the food, water, and energy sectors (Tashtoush et al. 2012; United Nation (UN) 2015):

- SDG 2 (Zero Hunger): End hunger, achieve improved nutrition and food security, and promote sustainable agriculture.
- SDG 6 (Clean Water and Sanitation): Ensure availability and sustainable management of sanitation and water for all.
- SDG 7 (Affordable and Clean Energy): Ensure access to reliable, affordable, sustainable, and modern energy for all.
- SDG 13 (Climate Action): Taking action to combat climate change and the impacts.

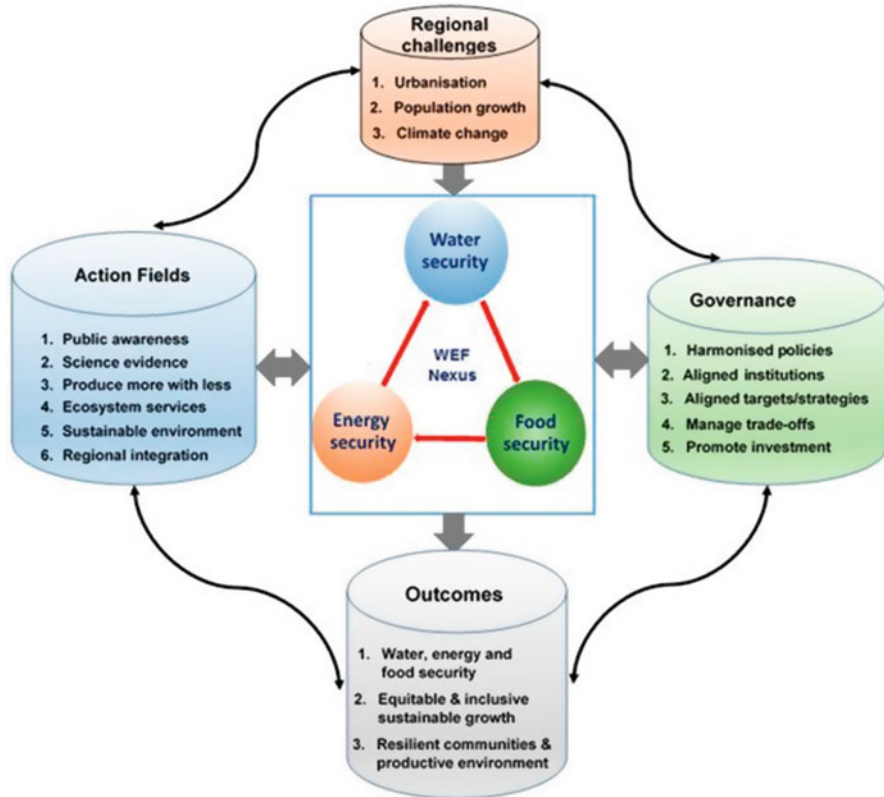
Although these four goals directly relate to the individual areas of climate change, water, energy, and food security, progress in 12 of the 17 SDGs is directly related to the sustainable use of resources. Some goals cannot be achieved without a holistic view of the nexus.

## **Energy Security and Pursuit of Water, Food, and Earth System Resilience**

Energy security exists where there is uninterrupted availability of energy sources and distribution at an affordable price to the consumers. With frequent power rationing (load shedding) in many African countries that ranges in hours, this remains a dream in achieving adequate energy production, stable tariffs, relax policies on independent power production (IPP), political stability, intelligent distribution of energy, green buildings, smart metering, energy auction, bidding and pricing, self-driving cars, electronic cars, energy storage, smart cars, high-speed trains, next-generation GPS devices, autonomous vehicles, gyroscopic vehicles, smart roads, hyperloops, micro-mobility, intelligent electric vehicle networks, etc. All of this lies on policies and politics.

The food challenges from energy perspectives include increasing food cooling systems; energy-intensive farm operations; local food chains that is minimizing transport energy; extended crop seasons; artificial intelligence and blockchain technology on food tracking systems; use of remote sensing technology (i.e., drone use for mapping, irrigation, and spraying) to monitor food production, spraying and irrigation; use of hydroponic and aeroponics for urban farming; use of drone to monitor crop production and pest controls; use of robotics technology in farming; and use of artificial intelligence in detecting crop diseases at an early state which all needs intensive use of energy and technology literacy.

The water challenges from energy perspectives include energy intensive of desalination, water reuse, rising demand for carbon-free energy systems, climate change raises water needs of energy, water allocation to energy generation, water capture from atmosphere (humid ambient air) using solar-powered devices, and



**Fig. 2** Conceptual framework of the regional water-energy-food nexus action plan

decentralized wastewater treatment (online wastewater treatment and monitoring using sensors).

The future of transportation lies on our behavior, culture, taboos, and way of life. How often one drives the vehicles, the mode of transport we take, the types of fuels we use, an investment in public transportation, compensation due to shift and investment on green energy (green funding), congestion charges, and more vehicle-pooling and ride-hailing services justify dependence toward zero emission and thus mitigation to climate change. Figure 2 shows the conceptual framework of the water-energy-food action plan (Nhamo et al. 2018; Chirisa and Bandauko 2015).

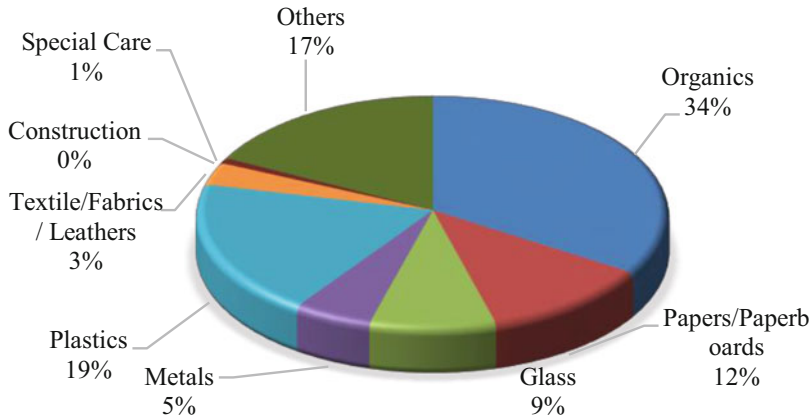
### **Reliable Integrated Waste Management and Nexus**

The populace development, urbanization, economic advancement, and improvement in expectations for everyday comforts in disruption of Industry 4.0 (4IR) have increased the amount of the waste generation in the cities and reintroduction of the emerging contaminants into waste streams. These wastes pose sanitary, health hazard, and environmental risks. These contaminants end up in water bodies and landfills, prompting to pollution of the entire environment, thus putting a high strain

on social, economic, health sector, and climate change. Tackling integrated waste management disruption and energy security requires stipulated regulation and policies that coordinate waste administration frameworks. The future of digital disruption and transformation of industrial platform, energy-water-food generation lies on the decarbonation, decentralization, electrification, and digitalization (sustainable industrialization and diversification in the digital era). Technologies in the era of digital transformation are becoming commercially viable to the integrated systems and services that enable sustainable management and efficient integrated waste management (IWM), energy production, and use. Reliable IWM and data provide an all-inclusive resource for a critical, comprehensive, and informative evaluation of IWM options in all integrated waste management programs. Optimized programmed operations using predictive analytics (i.e., conventional and AI modelling), big data, blockchain, e-citizens, fintech, and data mining are the fundamental apparatuses generally used to assess the policy impact and technology of savvy arrangements, just as to design the most ideal approaches to move from current to more intelligent urban areas. There are several obstacles confronting municipal solid waste management within the cities. Some of such obstacles are interrelation of urbanization and economic growth; change of living standards that causes complexity of the waste stream; overstretching of the superannuated infrastructure; lack of location and facilities to expedite waste separation at source; Intelligent Network Infrastructure (tracking collectors, IoT bins, automated recycler with incentive to users, available recycle plants); and integrated waste management technologies that are handy and costly compared to landfilling and composting. Detachment of waste at the source and embracing zero waste financial motivation urge a family to diminish squander.

The organic waste can be changed over to vitality utilizing waste to vitality elective courses that incorporate transformation, gasification, combustion, pyrolysis and liquefaction, organic procedures, aging, hydrolysis, and anaerobic assimilation for biogas and biomethane creation. An investigation waste quantification to assess the sustainability, characterization to assess the composition, and anaerobic digestion to assess the amount and quality of energy (CH<sub>4</sub>) generated by the City of Johannesburg were carried by a team of researchers (University of Johannesburg). The outcomes indicated that 1,444,772 tons per annum of local waste were created in the city of six million residents consistently as announced by the City of Johannesburg (CoJ), South Africa Pikitup (2017). Littering alone costs the city 5.7 million dollars every year, while illicit dumping costs another 6.2 million dollars for each annum. Organic waste can be changed over to vitality utilizing waste or vitality elective courses that incorporate transformation, gasification, combustion, pyrolysis and liquefaction, organic procedures, aging, hydrolysis, fermentation, and anaerobic assimilation for biogas and biomethane creation. Recyclable squander (paper/paperboards, plastics, and glass) was the second biggest part 12%, 19%, and 9%, respectively (Matheri et al. 2018a, b; Matheri 2016, 2020; Fig. 3).

The generated biomasses had potential of the alternative clean fuel production to meet the energy security and climate change mitigation. The physiochemical properties of the biomass showed the energy value equivalent to natural gas. The generated energy will contribute to a reliable, affordable, carbon-neutral, sustainable



**Fig. 3** Quantification of waste generated by the City of Johannesburg, South Africa

form of modern energy. This will help in the development of the conservation of biodiversity, waste management, poverty eradication, and adequate waste to energy recovery management strategies and improve living standards of the citizens (Matheri 2016). The energy system disruption will assist to bridge the gap in the implementation of the SDGs and fourth industrial revolution. The high number of plastic calls for the introduction of the bioplastics to protect the flora and fauna. This adds up pressure on the added value recycling and reduction of waste to landfills. The climate change future policy in developing countries is likely to be both promoted by climate technology transfer and public-private cooperation (cross-sector partnership) through the technology mechanism of the nexus and inclusion of the gender.

### **Water Security and Pursuit of Energy, Food, and Earth System Resilience**

Water is inseparably linked to food and energy production. The interdependence of energy on water is seen in transport, extraction, power generation, irrigation of biofuel crops, processing of fossil fuels, fuel cells, energy storage, etc. (Birol 2012). The emerging issues are cultivated on the regions that are facing adoption of the appropriate water management policies, water scarcity, and approaches fostering the allocation and sustainable use of resources while promoting economic growth. Due to human activities and availability of the water resources, Africa is one of the most vulnerable regions. In order to maximize the efficiency of using the resources, nexus is offering an integrated approach that analyzes the synergies and trade-offs between different sectors whereas adapting optimum institutional and policy arrangements (Markantonis et al. 2019). Lifecycle approaches are widely used by the industry for the assessment of the risk water management. The absence of lifecycle database to complement developing countries' databases is a challenging

issue that extensively improved the national accounting system. More positive economic opportunities are created in desalination technologies, smart metering, leak detection (prevent water loss), online water treatment, sensor technology in parameters detection, and smart use of ecosystems to collect and store water and carbon. Water security encourages the population to increase capacity of sustainable water access with adequate quality and quantities for human well-being, sustaining livelihoods and socioeconomic development. This ensures the protection against water-borne diseases, emerging contaminants, and water-related disasters by preserving a climate with peaceful ecosystems and political stability (Hassan et al. 2018; Matheri 2020; UN Water 2013).

The food challenges from water perspectives include raises irrigation demands, diminishing institutional that influences the irrigation schemes, groundwater pumped variables, production shifts poleward, higher elevation, water and wastewater treatment and reuse of the resources (Scott et al. 2018). The energy challenges from water perspectives include low water footprint solar PV and wind, dry cooled thermogeneration, water footprint of multiple energy portfolios, energy generation degrades water quality, energy generation from water resources (hydropower, fuel cells, anaerobic digestion), and energy storage (Scott et al. 2018). Construction of the decentralized solar-powered desalination systems in the dry areas will be one of the game changer deployments of the sustainable technology solution in disadvantaged communities in developing countries. This helps bring millions of liters and address perennial water shortage and thus reduction of water-borne diseases.

### **Water Pricing**

Water pricing currently is often underestimated which is fundamentally of importance in the economic issues that affect the implementation of the nexus on water use. Water pricing is an economic instrument which efficiency depends on the designed and implementation of the WEF nexus framework and investment. This is with regard to the policy choice, economic pursuit, realities, environmental, social, opportunity cost, and cultural cost. Developing countries' adaptation of the EU members' states law and policies on water pricing is one of the key goals in sustainable development (Markantonis et al. 2019).

### **Food Security and Pursuit of Water, Energy, and Earth System Resilience**

Food production needs energy, productive land, and water to grow crops, process food, and maintain livestock. Organic fraction of waste can also be put into value by converting and generating energy via anaerobic digestion and fermentation processes, while other technologies go more to gasification and direct combustion to generate energy and organic fertilizers (Matheri 2020). Such bidirectional links are complicated by the specific external factors that modify the chemical and physical characteristics and composition of water flows. Food consumption (changing dietary habits) and generation of the food waste have large effects on the nexus. This is yet to

be accounted in SDGs and cannot be treated with isolation from one another and alternative in the attainable chosen pathways in the water and food systems. Food security exists when everyone, at all times, has economic and physical access to adequate nutritious, safe, and sufficient food that meets their specific dietary preference and needs for an healthy and active life (Hassan et al. 2018). The water challenges from food perspectives include land degradation (salinization), water use, wastewater use for food production, supplemental irrigation of rainfed land, high water footprint of agriculture, and ensuring water allocation to irrigation. The energy challenges from food perspectives include mitigate hydropower-farming trade-offs, energy intensification of agriculture, energy intensification of the biofuel production and food transport, and competition between energy production and food security. One of the futures of food in climate change is podcast on the plant-based meat change to counteract the intensive use of energy.

## Biophysical and Biogeochemical Land-Climate Systems

The evidence of the land cover matters and climate systems is on early paleoclimate model studies and impacts on human-induced deforestation at margined regions. Changes from land conditions due to human activities affect the global climate change. This is driven by changes in emission removals of the GHGs (e.g., CH<sub>4</sub>, CO<sub>2</sub>, N<sub>2</sub>O) by biogeochemical effects. Any land redistribution and local changes on the water vapor and energy between the land and atmosphere influence the biophysical effects on regional climate. The terrestrial biosphere interacts with oceans through influx of nutrients, carbon cycle, water, and particles. This interaction affects crop yield, frequency heat waves, intensive heat waves, rainfall, and air quality. Land has net sources of 441% of the CH<sub>4</sub> emission between 2006 and 2017. IPCC has established GHG inventories and earth system models (ESM) on deforestation and afforestation as to reduce the anthropogenic CO<sub>2</sub> emission. This combines biophysical and biogeochemical processes to the land-climate system processes. IPCC reports that about one-quarter of 2030 mitigation pledges by countries in initial nationally determined contributions (NDCs) under Paris Agreement is expected to come from land-based mitigation (Jia et al. 2019). Some of the mitigation responses have a response option on technical potential for >3 GtCO<sub>2-eq</sub> year<sup>-1</sup> by 2050 through reduction of the carbon dioxide. These technical aspects include afforestation, waste to energy (bioenergy), wastewater recycle, and carbon capture and storage (carbon dioxide removal-CDR). The estimate includes sustainability and cost consideration with social-economic consideration on the climate changes or non-GHG climate forcing. Rising CO<sub>2</sub> concentration limits stomatal opening of the moisture content in the soil, thus reducing transpiration (land-based water cycle/hydrological on climate change). This increases the aerosol levels, declines surface winds, and increases solar radiation to the ground. The impact of the climate-related extremes on land includes the disruption of the water-energy-food production and supply chain, alteration of the ecosystems, hydrological cycle, surface temperature, atmosphere composition, morbidity and mortality, and damages of the infrastructure



and settlements and human health. Advanced knowledge and optimization of the mitigation and adaptation with coordination of the sustainable land use and management across all sectors are required to achieve better livelihood, food security, energy security, and water security and improve human health, biodiversity, quality of the local environment, and equitable sustainable development. This is through the modification of the regional and global climate change, seasonal and annual climate variation, extreme weather, and human activities on the land, e.g., deforestation, afforestation, and forest management. Incorporating land-climate processes into climate projection allows emotional intelligence and artificial intelligence to take shape through understanding land's response to climate action and better quantify the potential of land-based response options for the mitigation of climate change (Jia et al. 2019).

---

## **Nexus Contributions to Job Market**

When developing or implementing a nexus, approaches with regard to minimization of high transaction costs should be an added value in economic measurement. Furthermore, energy and water generation and distribution have high characteristics of being monopolized in the developing countries. This creates merits and demerits to the end users. In general, the CLEWS' nexus has great potential to create new job opportunities and improving living standards in the developing countries. There is a higher need to accelerate the process of the WEF management of emergence of new employment opportunities. Investment of the research and development and implementations on nexus approaches could induce a positive economic effect through job creation. Other disrupted sectors should further be redeveloped, attracting additional meaningful investments and producing new employments within a nexus framework of policies and governance, auditing, and monitoring. Governments have the biggest role to play in the nexus implementation either by making relevant policies or providing funding that subsidizes new technologies and contributes to the welfare of society and enrichment of the emerging market gap.

---

## **Carbon Tax**

Developing countries' economic transformation and creation of employment through green economy and digitalization will be one of the COP26 green deal agendas. This is with the transition of the national development goals (NDG) 2030 and transition of the low-carbon economy and sustainable development goals as per the economic partnership agreement between the European Union (EU) and developing countries. The commitment through policy-making is paramount in the carbon taxation. The carbon tax is levied on carbon content of fuels (energy and transport sector) and carbon emission trading in the form of carbon pricing (CO<sub>2</sub> equivalent tax/pollution tax). The tax offers potentially cost-effective means of the reduction of the greenhouse gas emissions by shifting the cost from society to companies that

create the emissions (the more the emission, the more the cost). South Africa has spearheaded the developing countries in the carbon tax 2019 (carbon tax act No.15 of 2019) meant to curb the carbon emissions (green house emission, industrial processes, fuel combustion, and fugitive emissions) as mitigation to climate change, which is cost-effective and economically efficient. The cost of the impact of climate change to food pricing, water, infrastructure, health, conflict, and disasters tends to shift to polluters (global economy shifts toward lower carbon economy). The impact of crop disease and rainfall changes, extreme storms and drought, and temperature changes has shift changes in food prices and food security. This has direct impact on the carbon taxation (Republic of South Africa ZA 2019).

---

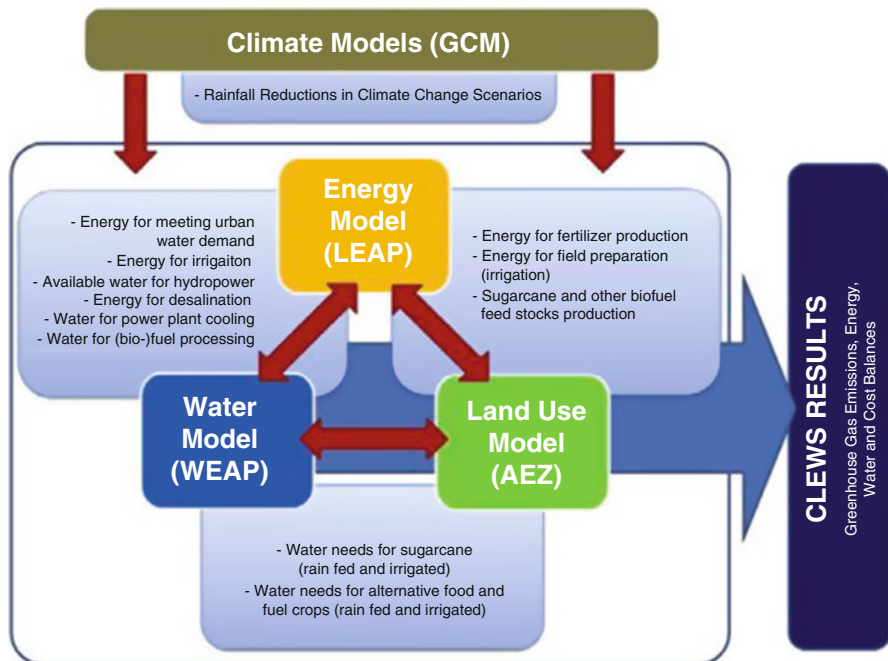
## Data-Driven Nexus

It is a big challenge to relatively obtain national data for the nexus. Small numbers of bodies (e.g., IRENA, World Bank, IEA, UN) share production, transformation, and consumption data. This remains a key challenge in the mitigation of climate change. Examples of data include water evaporations rates from hydro-powers, flood controls or irrigation, water requirement in energy production and food production, mixed SI units on the data presentations, pattern use of water with regard to locations. Data gap is even larger if fully life cycle of the technology is considered (Ferroukhi et al. 2015).

Matters concerning the big data in nexus' availability and accessibility should be of high priority in policy-making. Nexus is based on a holistic environmental and economic perspective, which should use reliable, consistent, and comprehensive data. It is also imperative that data source across the nexus sectors is comparable in terms of resolution and accuracy. Efficiency in implementation of the nexus is dependent on high-accuracy economic databases that support sustainability. Research and development, scientific institutions, and stakeholders can initiate the collection of open data, in order to build a sustainable database for analyzing the nexus. This can add value and be generated only through workable partnerships between the private-public sector, NGOs, knowledge institutes, and local and regional stakeholders (Markantonis et al. 2019).

## Industry 4.0 in Nexus and Climate Resilient

The nexus pillars of sustainable development need to be explored in the numerical modelling (i.e., economic modelling; kinetic modelling; life cycle assessment (LCA); WEF modelling; multi-criteria decision analysis (MCDA); CLEWS' modelling; resource flow; network analysis; remote sensing, geospatial, and hydrologic models; finance models; climate models; material and energy models; land-use models; institutional analysis; environmental management; indicator models; social science and integration models; system analysis) (Albrecht et al. 2018). The climate change estimation is based on the sparse station coverage, particularly on scrutiny of



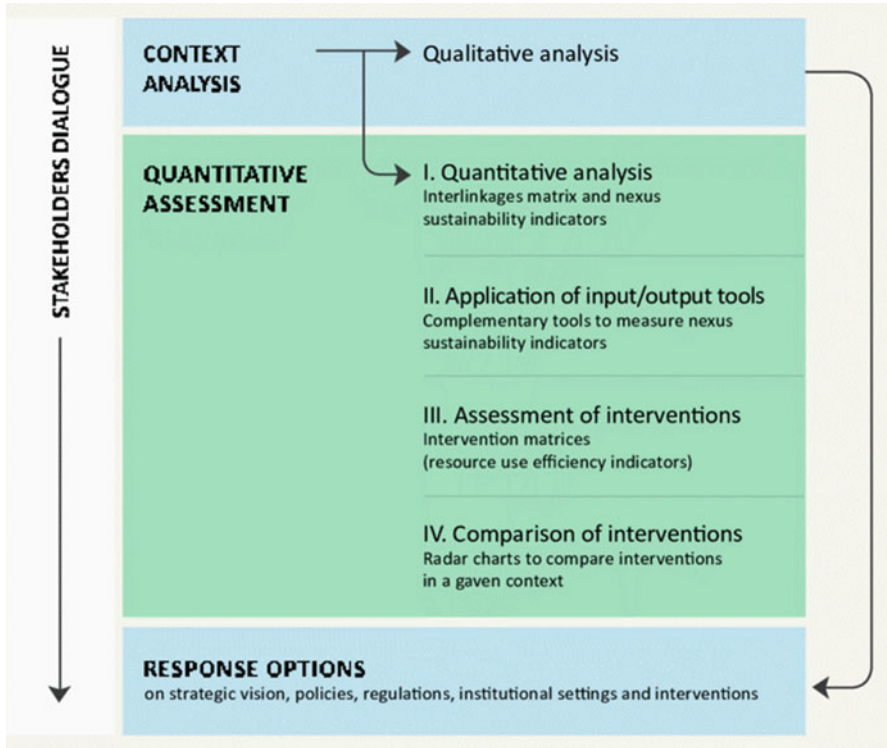
**Fig. 4** The CLEWS' framework founded upon the LEAP, WEAP, AEZ, and GCM models

GDP data. Lack of transparency in data sources and collection methods, lack of details on methods of aggregation, and lack of metadata have led to differences between GDP estimates, adjustment to historical data, nonrandom errors, and inhomogeneity in time series. Good quality data is paramount to reliable physical and economic modelling of the nexus and climate sector (Conway et al. 2015). Climate, land, energy, and water systems (CLEWS) are integrated. The CLEWS' resource assessment and interlinkages with new paradigms are presented in Fig. 4 (Howells et al. 2013; Welsch et al. 2014).

The CLEWS serve as highlights and dynamics that overlook the system approach to sustainable development. The CLEWS' framework is developed by integrating the LEAP (energy), WEAP (water), GCM (general circulation model, climate), and AEZ (agroecological zoning, land) to produce the GHG emissions, water, and energy balance. The model outcome exercises policy development and resource assessment approach through linking existing single-resource modelling tools (Howells et al. 2013; World Bank Group (WBG) 2016).

### Modelling of the Water-Energy-Food-Land-Climate Nexus

The climate-water-energy-food-land are indirectly and directly interlinking. Nexus unique assessment and monitoring is based on indicators and interlinkages to better



**Fig. 5** FAO component of the nexus assessment

understand the potential synergies and trade-offs. Quantification and characterization are mostly needed in decision-making. Nexus modelling and framework are classified as (Hassan et al. 2018; Bizikova et al. 2013):

- Type of models: quantitative analysis models, simulation models, and integrated models
- Geographical scale in addressing intercountry levels

Figure 5 indicates the components of the nexus assessment (Hassan et al. 2018).

For example, assuming change in water ( $\Delta W$ ), reduces freshwater availability and create shift in energy ( $\Delta E$ ) with limiting cooling power that leads to load shedding (power rationing) and water scrubber thus increase shift of climate change ( $\Delta C$ ) and land use. The interlinkages are unique and can go to any directions. The 20 interlinkages are summarized below:

- Water: WL, WF, WE, WC
- Energy: WL, EF, EC, EW
- Land: LF, LW, LC, LE

- Food: FE, FE, FL, FC
- Climate: CF, CW, CE, CL

The analysis of the interlinkages can be analyzed well by the use of artificial intelligence tools (e.g., artificial neural network, ANN), statistical tools (e.g., multi-criteria decision analysis (MCDA)), and conventional modelling concepts. The nexus pathways can be restructured in the first to fourth order. Similar nexus can be constructed with fourth-order interlinkages for the whole nexus making it 120 (Laspidou et al. 2018). The multicentric approach will add complexity with inter-connection, trade-offs, and drives on nexus assessments (Simpson and Jewitt 2019).

---

## **Adaptation of Climate Change Technology Transfer in Developing Countries**

Currently, combating anthropogenic climate change in developing countries is carried out through the transfer of environmentally sound technologies (EST). This is a widely recognized priority for global environmental policy. Climate change technology transfer and policy analytics are of high success factors underlying collaboration between private and public sectors in developing countries. Climate change future policies in developing countries are likely to both be promoted by climate technology transfer and public-private cooperation (cross-sector partnership) through the technology mechanism of the water-energy-food nexus and inclusion of the gender. Building partnership mechanisms can reduce cost and increase local clean development mechanisms (CDM). The difficulties in achieving the CDM include first a sidelined investment by investors on diversifying a project away from cheap forms of climate change mitigation by increasing cost and broader development outcomes. Second, the technology dividends are uncertain and often reflect on preference of host government or deliberative processes involving the stakeholders. Third, green climate fund shortage or project investment guidelines combine production cost, human capacity, and innovator multi-disciplinary. Overcoming the barrier allows the smart climate-resilient and efficient integrated energy-water-food nexus system in a developing country: Industry 4.0 with climate change friendly investment to proceed quicker and implement the development dividend (Forsyth 2007). The costs of climate technology transfer and increase local representation in establishing the development dividend can be reduced by cross-sector partnerships (CSPs). CSPs can comprise of orthodox public-private partnerships, where governments make contracts with a private-sector company in order to provide Intelligent Network Infrastructure or services more efficient than the state (Forsyth 2005, 2007). Climate change policy and technology transfer minimize the transaction costs, strengthen the collaboration, build capacity, increase public trust and accountability, and enhance environmental governance under the climate change convention and application of the CDM (Forsyth 2005; COP25 2019b).

---

## Nexus and Research Gap

The concept of the nexus has been received in the business, academics, and policy sectors with a few implemented projects on the ground. The major discussion is how to implement and shift from the ideal concept of the theory based on practice and policies. The nexus methodology emphasis on water-food is majorly researched on hydrological, ecological, and agronomic integrated models and analysis with limited focus on the governance issues of the resources. Versatile methodology to quantify the interlinkages between the WEF and climate change is required. Improving the formulating existing methodology and practices is of high priority to advancing the adoption of the nexus approach. Lack of the reliable data (big data/open source) in the digitalization, electrification, decentralization, and decarbonation world (fourth industrial revolution, Industry 4.0) is a major barrier toward implementation of the WEF nexus approach. Lack of the reliable comprehensive analytic tools is another highlighted concern. Development of critical soft skills (sciences/social/business, STEM) in integrated software and online platform is helpful in addressing the potential synergies and trade-offs in the nexus. Convectional models and AI-based models' development is of a big challenge, and a big question is how nexus and climate change interact and are quantified. In providing important strategies for the SDGs, the integrated models and managements for developing countries is enhanced.

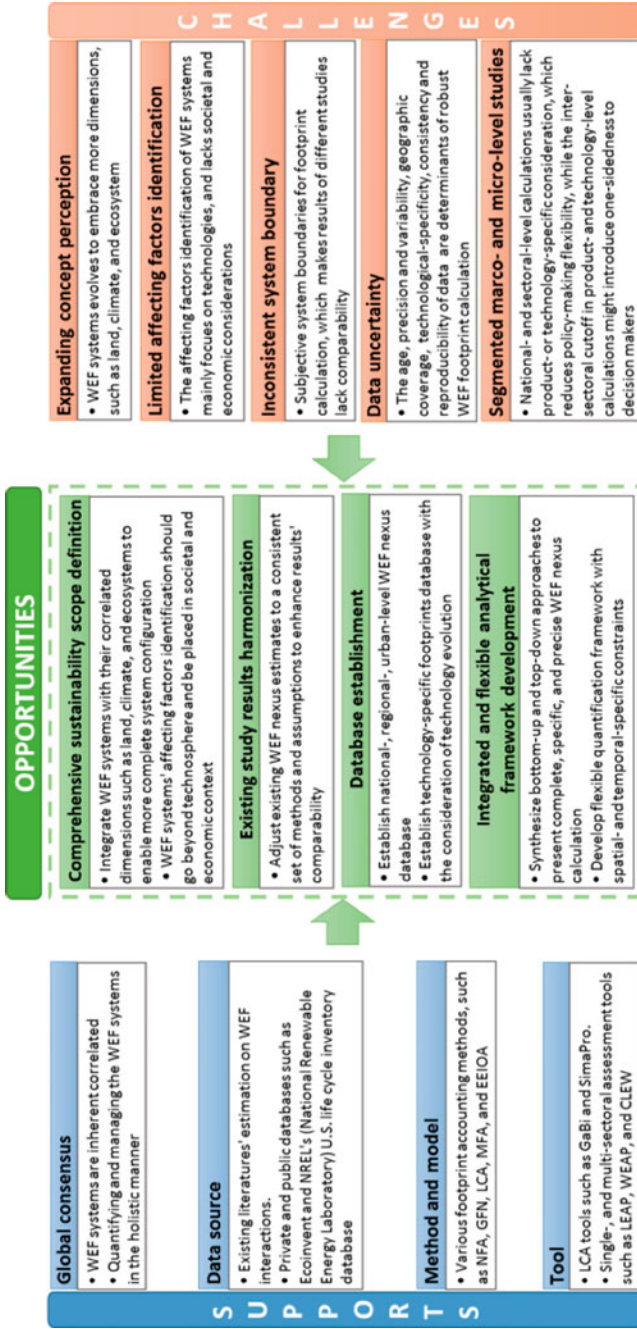
Climate change on the WEF is another critical aspect of high importance on resource availability, distribution, and interconnection to the WEF. How does climate change affect the nexus? What are the impacts of climate change to the nexus? Which agent of change needs to be implemented in WEF NEXUS? Is there political good will in the addressing climate change? What are the governance and policy coordination in place? These fundamental aspects can be addressed based on smart climate-resilient and efficient climate change adaptation, international commitment, corporation and stewardship, new and refurbished green infrastructure projects, green funding, reward and awarding the environmental champions, and payment for ecosystem services (Hassan et al. 2018). The methodological challenge, supports, and opportunities that are associated with robust quantification of the WEF nexus are indicated in Fig. 6 (Chang et al. 2016):

---

## Analytics Framework

The nexus provides a set of guidelines that aims in creating a great and equal level playing field for all sectors while achieving the aims of the SDGs that are multilevel approach and cross-sectoral to climate change. This comprises of six categories (Hoff et al. 2019):

- Nexus framing creates specific understanding on key issues from that which explores the interlinkages between the different sectors and resources.



**Fig. 6** Methodological challenge, supports, and opportunities that are associated with robust quantification of the WEF nexus

- Nexus opportunities create a category on how to identify a new approach and adding values in context by improving cross resources productivity, reducing resources and environmental degradation, reducing human insecurities/unemployment/poverty, and increasing climate resilience.
- Technical and economic nexus (nexus savings) assesses possible potential benefits from implementation of nexus approaches through multifunctioning production systems, cross resources, and cross-sector recycling.
- Stakeholders' involvement specifies different types and levels of stakeholders involved in the nexus, e.g., private-public sectors and civil society in overseeing the implementations.
- Conditions' framework addresses factors such as policies, technical solution, scalability, initialization, bridging mechanisms, integration of SDGs and NDGs, and innovations (start-ups, incubation, and entrepreneurship).
- Monitoring and evaluation (M&E) serves as an indicator for the required data for implementation of the nexus. This is because it is dynamic objectives, composition of stakeholders, and processes.

The overall methodology of the WEF nexus management approach is performed in three steps (see Fig. 7): (1) overview characterization (identifying and quantifying the connectivity between nexuses), (2) integrated models and analysis (climate-land-energy-water) of the nexus system, and (3) performing future management scenarios to help policy and decision-making (Tashtoush et al. 2012).

The nexus framework is seconded by the holistic resources planning showed in Fig. 8 (Kulat et al. 2019).

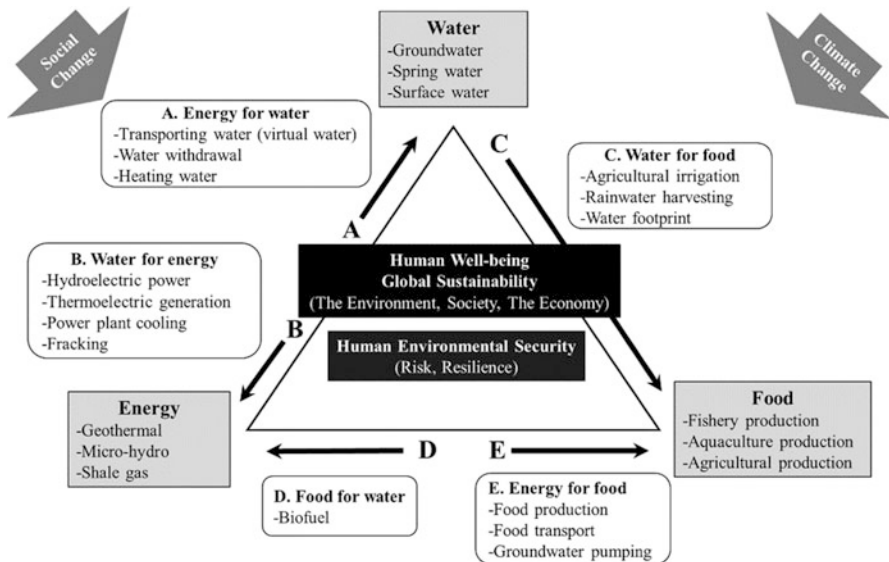
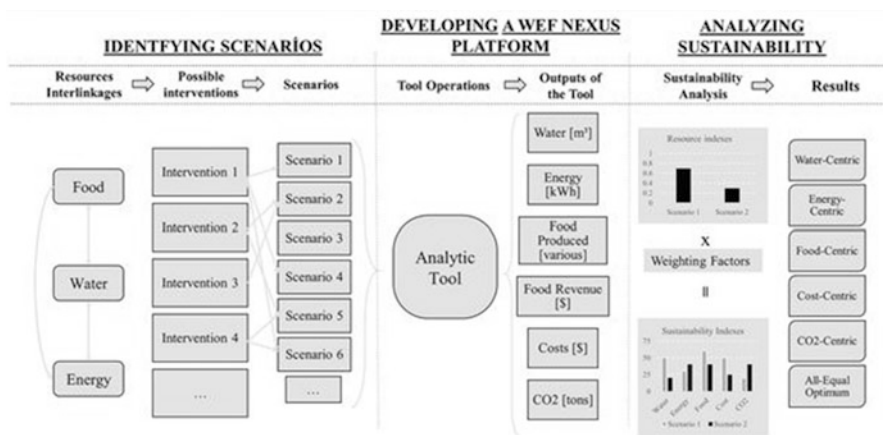


Fig. 7 Water-energy-food nexus analytics framework



### Nexus Securities and Environmental Protection

Climate change intensifies high competition and trade-offs between the WEF resources. The potential impact of the climate change is manifested by rise in temperature, more energy demand, and more water demand. Urbanization and population increase (industrialization) account for the 75% of the energy consumption and emission of the 75% of the greenhouse gases (GHGs). This creates high opportunities for the decentralization, decarbonization, and digitalization systems that improve the resource efficiency and implementation of the nexus approached. Suitable adaptation of the climate change demands efficient use of water, energy, and food resources to fight against vulnerability. Figure 9 illustrates the conceptual



**Fig. 8** Holistic water-energy-food nexus resources planning

**Fig. 9** Conceptual framework of the water-food-energy nexus and climate change integration

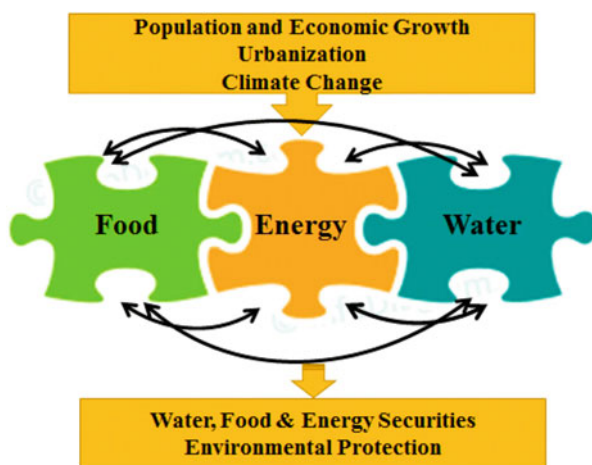


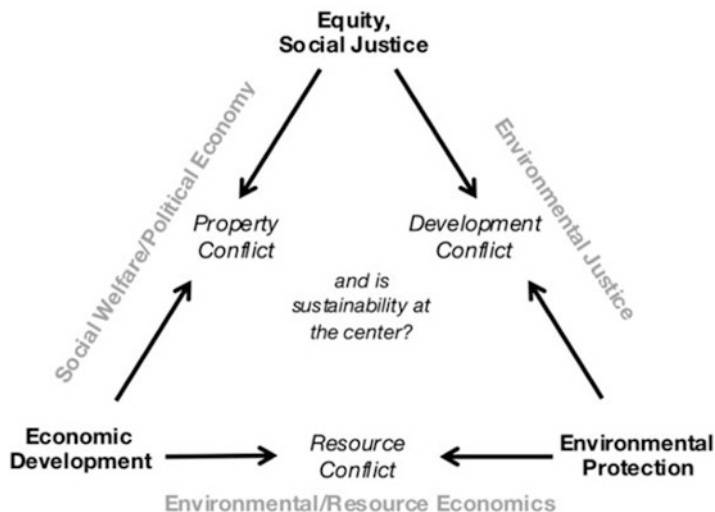
diagram of the WEF nexus with link between the WEF and climate change integration (Tashtoush et al. 2012).

The global emission of carbon dioxide has increased with almost 50% since 1990. The SDGs and NDGs cannot be achieved without addressing the climate emergence (SDGs, UN 2019). The region that is vulnerable to climate change encourages to adapt measures that are implementable and have surety of the WEF security. Enhancing efficiency of small-scale water supply systems and consolidated small services helps reduce vulnerability to climate change of the systems (policy initiative to adapt the climate change in water sector); collaboration in data collection and analysis to mitigation of climate change are key to sustainability of the WEF nexus. Adaptation of the climate change can be improved by building ecological networks that connect ecological to local governments, thus improving decision-making. Spatial equilibrium models seek to optimize resource allocation in various scales, thus providing realistic estimates of the value and into accounting alternative use of the disrupting technology. WEF nexus needs to be integrated to a smart climate resilient with inclusion of the governance and stakeholders. This serves as a comprehensive tool in decision-making toward sustainable resources in climate change (Volk 2014; Daher and Mohtar 2015). Recognition of spatial and sector interdependencies should inform policies, investment, and institutions for enhancing WEF security and climate change (Conway et al. 2015).

---

## **Policy and Governance (Coordination and Collaboration) for Climate Change**

Climate gas (GHG) emissions and climate risks in countries are not only city government's concerns but also rural government oversight concerns (climate governance). The drivers, consequences, and dynamics of climate change cut across jurisdictional boundaries that require collaboration and coordination of governance across nongovernment and government sectors. Climate change governance is within broader political and social-economic context negotiable with Conference of the Parties (COP) to the UNFCCC (Romero-Lankao et al. 2018). Strategies, policies, and plans provide guidelines and framework for practical coordination and collaboration on CLEWS. Overarching climate change policies integrate the practical collaboration and giving timeline to the policies and their inclusion of climate changes and nexus. Persistence of these strategies recognized a gap in governance (policies and planning). The emphases on a formal model of contract may disincentivize regular collaboration and not only the barrier to cross-sector collaboration and coordination but budge and financial agreements. The issues of the regional security (power imbalance) are a sector interest overriding the climate change agenda. The integrations of the national-level strategies, planning, policies, and age and gender inclusion encourage action on climate change (Pardoe et al. 2018). Increase policy synergies among transformative investments that require a holistic approach with process innovation that fueled a higher level of nonhuman and human capital. Formation of the transboundary with globalized decision-makers



**Fig. 10** Three fundamentals of planning

creates integration and enhances benefits through the climate-land and WEF nexus and equitable distribution. Creation and promotion of the gender equality environment enhances the nexus investments and implementations with enhanced family wealth that widens skills and knowledge (Mishra et al. 2019; RES4 Africa Foundation 2018). Collaborative, informed decision-making and equitable needs in transformation response of the climate change as well as fundamentals of the legal framework, leadership, land-use regime, land ownership, energy use, food production and distribution, public participation, information sharing, financial resources, growth, and ethos shape the climate change governance (Romero-Lankao et al. 2018). The three fundamentals of planning are presented in Fig. 9. It consists of the development conflict, resources, and property with three broad political/social institutions to manage environmental justice, regulation, environmental economics, and social welfare (Campbell 2013; Fig. 10).

Despite deficiency, state, government, provinces, municipalities, counties, and nongovernmental and governmental action on addressing climate change the jurisdiction over many dimensions of adaptation and mitigations reside on financial and technical capability and policies that hold greatest potential to create legitimate and effective response strategies (Romero-Lankao et al. 2018).

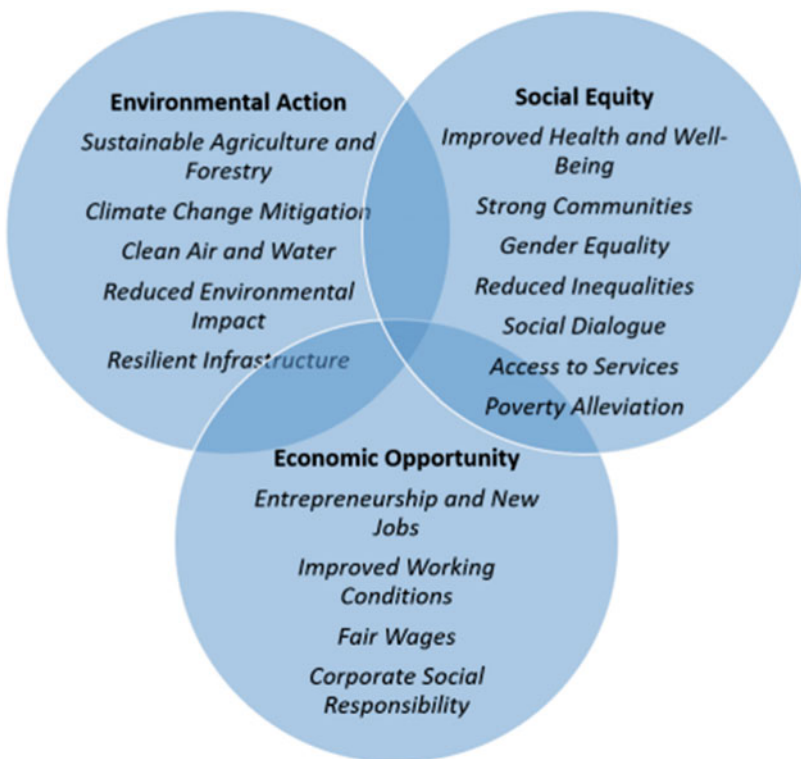
---

## Equity, Climate Change, and Environmental Justice

Major cities are characterized by socioeconomics of different diversifications that are often accompanied with the stratification on gender, race, professional classes, cultures, age, ethnicity, and ability. This gives rise to endure climate stresses and

minimize climate risks. Lower social class, disadvantages in the community, hazard prone areas, ethnics, and racial minorities increase their susceptibility to the impact of climate change and reduce their capacity to adapt (Rosenzweig et al. 2015).

Climate change vulnerability is driven by (1) resource influence by social characteristics, (2) ineffective planning and absence of community engagement due to governance and institutional weaknesses, (3) failure of the urban developers in providing accessibility to critical infrastructures and services, and (4) occupational health that leads to physical exposure at different levels. As the climate event such as drought in prone areas becomes more frequent and intense, this can increase the scale and depth of poverty overall. Gender inequality is pervasive and cuts across to disability, income, and literacy that in turn contribute to differential consequences of climate change. Mobilization of the resources increases environmental justice, and equity of climate change requires participation of the locals, international bodies in involvement of the nontraditional resources, finance civil society, public-private sector, monitoring and evaluation, and principles of transparency (Reckien et al. 2018). Figure 11 indicates the interconnected benefits and dimensions of inclusive climate action.



**Fig. 11** Interconnected benefits and dimensions of inclusive climate action (Reckien et al. 2018)

The primary goal in achieving environmental justice and equity in climate change is for the urban climate policies to foster human beings, economic and sustainable social development, social capital, access to land, security tenure, risk reduction infrastructure, access to CLEWS; integrate community and stakeholders, in decision-making; adjust climate change policies by ensuring resilience and equity goals; and develop a periodic monitoring and evaluation using fair indicators and progress measurement, resilience objective and feasibility, equitable resources, budgetary transparency, resource allocation scheme, and equitable resilience outcomes (Rosenzweig et al. 2015; Reckien et al. 2018).

---

## Conclusion and Recommendations

The CLEWS nexus is a concept of integration that accesses the resources such as water, food, and energy that are inextricably dependent and linked to one another and have a strong interaction with the environment and climate change. The interlinkages exist between nexuses that manifest in providing exploring opportunities that explore the disruption, policies, and alternatives for increasing the use of resources and sustainable resources management and minimizing the environmental impacts. The nexus and climate resilience offer great opportunities that integrate and manage the disruptive technology in a more sustainable manner by promoting local and regional cooperation and peace; harmonizing the policies, legislation, and strategies; creating proper resource coordination; improving resilience; and reducing vulnerability to attainment of the region integration in-line with SDGs. The impact of the climate-related extreme on land includes the disruption of the water-energy-food production and supply chain, alteration of the ecosystems, morbidity and mortality, and damages of the infrastructure, settlements, and human health. Advanced knowledge and optimization of the mitigation and adaptation with coordination of the sustainable land use and management across all sectors are required to achieve better livelihood, food security, energy security, and water security improve human health, biodiversity, quality of the local environment, and equitable sustainable development. Climate action future policy in developing countries is likely to be promoted by climate technology transfer and public-private cooperation (cross-sector partnership) through the technology mechanism of the water-energy-food nexus and inclusion of the gender. Building partnership mechanisms can reduce cost and increase local clean development mechanisms (CDM). Agenda 2030 sustainable development, Paris agreement, and national development policies are alignments to advance climate-resilient development and green deal that enhance sustainable future.

Recommendations arising include:

1. Great investments into nexus with strong collaboration of the multidisciplinary.
2. Governments should work together to achieve green circular economy with smart and intelligent novel solutions.
3. SDGs 17 need to be widely explored and policies clarified.

4. Development of new tools to investigate the interconnection of the WEF nexus with land and climate change.
5. Research and development should be enhanced before decision-makings on sustainability and efficiency.
6. Better understanding is required of the trade-offs between nexus and ecosystems.
7. It is important to take action of the spatial reach of intersectoral interdependencies (pricing, control instruments, and command) and effects in the multi-level governance systems to ensure appropriate participation by affected sectors and stakeholders.
8. Data shortages should be reduced by encouraging open-source digitalized systems with capacity building support on sustainable monitoring and data management systems.
9. Introduction and enhancement of the existing free trade movement on the borders will enhance reaching the SGDs more than expected.
10. Use of the artificial intelligence solutions (nexus and climate change digitalization) on WEF and land and climate change applicability in decision support management, i.e., machine/deep learning, blockchain, remote sensing, IoT, big data, etc.
11. Introduction of the climate change coding (code for climate change and nexus) will enhance early data analytics and action (action toward digitalization, digital earth).
12. Enhanced, efficiency and accessibility of the green climate funding will enable preparation, implementation, and strategic workstreams of national determined contributors and adaptation-related elements of the Paris Agreement. The mechanism will minimize and address loss and damages associated with climate change impacts of developing countries' parties.

**Acknowledgments** The authors wish to acknowledge the South Africa Water Research Commission (WRC), Project No. K5/2563 for funding; University of Johannesburg (UJ); Enel Foundation; European Union Institute; Process, Energy, Environmental Technology Station (PEETS) funded by Technology Innovation Agency (TIA) through the Department of Science and Technology (DST); SANEDI; City of Johannesburg (CoJ); Gladtech International, Kenya; South Africa's wastewater treatment plants; Innovation Hub; and water utilities, managements, and staffs for capacity building and knowledge transfer.

---

## References

- Albrecht TR, Crootof A, Scott CA (2018) The water-energy-food Nexus: a systematic review of methods for nexus assessment. *Environ Res Lett* 13(4):043002
- Birol F (2012) World energy outlook 2012. International Energy Agency, Paris, p 633
- Bizikova L, Roy D, Swanson D, Venema HD, McCandless M (2013) The water-energy-food security nexus: towards a practical planning and decision-support framework for landscape investment and risk management. International Institute for Sustainable Development, Winnipeg
- C40 (2020) <https://www.c40.org/cities>. Accessed June 2020

- Campbell SD (2013) Sustainable development and social justice: conflicting urgencies and the search for common ground in urban and regional planning. *Mich J Sustain* 1
- Carter S, Gulati M (2014) Climate change, the food energy water Nexus and food security in South Africa. *Understanding the Food Energy Water Nexus*, WWF-SA
- Chang Y, Li G, Yao Y, Zhang L, Yu C (2016) Quantifying the water-energy-food nexus: current status and trends. *Energies* 9(2):65
- Chirisa I, Bandaoko E (2015) African cities and the water-food-climate-energy nexus: an agenda for sustainability and resilience at a local level. In: *Urban forum* 26(4):391–404. Springer, Netherlands
- Conway D, Van Garderen EA, Deryng D, Dorling S, Krueger T, Landman W, Lankford B, Lebek K, Osborn T, Ringle C (2015) Climate and southern Africa's water–energy–food nexus. *Nat Clim Chang* 5(9):837–846
- COP25 (2019a) Enhanced Lima work programme on gender and its gender action plan. [https://unfccc.int/resource/cop25/cop25\\_auv\\_13gender.pdf](https://unfccc.int/resource/cop25/cop25_auv_13gender.pdf). Accessed June 2020
- COP25 (2019b) Enhancing climate technology development and transfer through the technology mechanism. [https://unfccc.int/resource/cop25/cop25\\_auv\\_9\\_TEC\\_CTCN.pdf](https://unfccc.int/resource/cop25/cop25_auv_9_TEC_CTCN.pdf). Accessed June 2020
- Daher BT, Mohtar RH (2015) Water–energy–food (WEF) Nexus tool 2.0: guiding integrative resource planning and decision-making. *Water Int* 40(5–6):748–771
- Ferroukhi R, Nagpal D, Lopez-Peña A, Hodges T, Mohtar RH, Daher BT, Mohtar S, Keulertz M (2015) Renewable energy in the water, energy & food nexus. IRENA, Abu Dhabi
- Forsyth T (2005) Enhancing climate technology transfer through greater public–private cooperation: lessons from Thailand and the Philippines. In: *Natural resources forum*. Wiley Online Library
- Forsyth T (2007) Promoting the “development dividend” of climate technology transfer: can cross-sector partnerships help? *World Dev* 35(10):1684–1698
- Hassan TA, Muhammad K, Ian M, Lars R, Justyna S (2018) The water-energy-food security Nexus; a review on Nexus literature and ongoing Nexus initiatives and policy-makers. *Nexus Regional Dialogue Programme (NRD)*
- Hoff H, Alrahaife SF, El Hajj R, Lohr K, Mengoub FE, Farajalla N, Fritzsche K, Jobbins G, Özerol G, Schultz R (2019) A Nexus approach for the MENA region – from concept to knowledge to action. *Front Environ Sci* 7:48
- Howells M, Hermann S, Welsch M, Bazilian M, Segerström R, Alfstad T, Gielen D, Rogner H, Fischer G, Van Velthuis H (2013) Integrated analysis of climate change, land-use, energy and water strategies. *Nat Clim Chang* 3(7):621–626
- Jia G, Shevliakova E, Artaxo P, De Noblet-Ducoudré N, Houghton R, House R, Kitajima K, Lennard C, Popp A, Sirin A, Sukumar R, Verchot L (2019) Land–climate interactions. In: *Climate change and land*. IPCC special report on climate change, desertification, land degradation, sustainable land management, food security, and greenhouse gas fluxes in terrestrial ecosystems
- Kulat MI, Mohtar RH, Olivera F (2019) Holistic water-energy-food Nexus for guiding water resources planning: Matagorda County, Texas case. *Front Environ Sci* 7:3
- Lapidou CS, Kofinas DT, Mellios NK, Witmer M (2018) Modelling the water-energy-food-land use-climate Nexus: the Nexus tree approach. In: *Multidisciplinary digital publishing institute proceedings*
- Markantonis V, Arnaud R, Karabulut A, El Hajj R, Altinbilek D, Awad I, Brugemann A, Vangelis C, Mysiak J, Lamaddalena N (2019) Can the implementation of the water-energy-food Nexus support economic growth in the Mediterranean region? The current status and the way forward. *Front Environ Sci* 7:84
- Matheri AN (2016) *Mathematical modelling for biogas production*. University of Johannesburg, Johannesburg
- Matheri AN (2020) *Mathematical modelling of biological wastewater treatment and bioenergy production processes*. PhD Thesis, Chemical Engineering, University of Johannesburg

- Matheri AN, Ntuli F, Ngila JC, Seodigeng T, Zvinowanda C, Njenga CK (2018a) Quantitative characterization of carbonaceous and lignocellulosic biomass for anaerobic digestion. *Renew Sust Energy Rev* 92:9–16
- Matheri AN, Mbohwa C, Ntuli F, Belaid M, Seodigeng T, Ngila JC, Njenga CK (2018b) Waste to energy bio-digester selection and design model for the organic fraction of municipal solid waste. *Renew Sust Energy Rev* 82:1113–1121
- Matheri AN, Eloko NS, Ntuli F, Ngila JC (2020) Influence of pyrolyzed sludge use as an adsorbent in removal of selected trace metals from wastewater treatment. *Case Stud Chem Environ Eng*
- Mishra A, Appadurai AN, Choudhury D, Regmi BR, Kelkar U, Alam M, Chaudhary P, Mu SS, Ahmed AU, Lotia H (2019) Adaptation to climate change in the Hindu Kush Himalaya: stronger action urgently needed. In: *The Hindu Kush Himalaya assessment*. Springer, Cham, pp 457–490
- Newell JP, Goldstein B, Foster A (2019) A 40-year review of food–energy–water nexus literature and its application to the urban scale. *Environ Res Lett* 14(7):073003
- Nhamo L, Ndlela B, Nhemachena C, Mabhaudhi T, Mpandele S, Matchaya G (2018) The water-energy-food nexus: climate risks and opportunities in southern Africa. *Water* 10(5):567
- Pardoe J, Conway D, Namaganda E, Vincent K, Dougill AJ, Kashaigili JJ (2018) Climate change and the water–energy–food nexus: insights from policy and practice in Tanzania. *Clim Pol* 18(7):863–877
- Reckien D, Lwasa S, Satterthwaite D, McEvoy D, Creutzig F, Montgomery M, Schensul D, Balk D, Khan I (2018) Equity, environmental justice, and urban climate change: climate change and cities: second assessment report of the urban climate change research network. Cambridge University Press, New York, pp 173–224
- Republic of South Africa ZA (2019) Carbon tax act 15 of 2019. [https://www.gov.za/sites/default/files/gcis\\_document/201905/4248323-5act15of2019carbontaxact.pdf](https://www.gov.za/sites/default/files/gcis_document/201905/4248323-5act15of2019carbontaxact.pdf). Accessed June 2020
- RES4 Africa Foundation (2018) Applying the water-energy-food nexus approach to catalyse transformational change in Africa. RES4Africa Foundation
- Romero-Lankao P, Burch S, Hughes S, Auty K, Aylett A, Krellenberg K, Nakano R, Simon D, Ziervogel G (2018) Governance and policy; climate change and cities: second assessment report of the urban climate change research network. Cambridge University Press, New York, pp 585–606
- Rosenzweig C, Solecki W, Romero-Lankao P, Mehrotra S, Dhakal S, Ali Ibrahim S (2015) The urban climate change research network (UCCRN) second assessment report on climate change and cities (ARC3–2), and the UCCRN hubs. Cambridge University Press, New York
- Scott CA, Kurian M, Wescoat JL (2015) The water-energy-food nexus: enhancing adaptive capacity to complex global challenges. In: *Governing the nexus*. Springer, pp 15–38
- Scott CA, Albrecht TR, De Grenade R, Zuniga-Teran A, Varady RG, Thapa B (2018) Water security and the pursuit of food, energy, and earth systems resilience. *Water Int* 43(8):1055–1074
- SDGs, UN (2019) Goal 13: take urgent action to combat climate change and its impacts. <https://www.un.org/sustainabledevelopment/climate-change/>. Accessed June 2020
- Seeliger L, De Clercq WP, Hoffmann W, Cullis JDS, Horn AM, De Witt M (2018) Applying the water-energy-food nexus to farm profitability in the middle Breede catchment, South Africa. *S Afr J Sci* 114(11–12):1–10
- Simpson GB, Jewitt GPW (2019) The development of the water-energy-food nexus as a framework for achieving resource security: a review. *Front Environ Sci* 7:8
- Stocker TF, Qin D, Plattner M, Tignor SK, Boschung J, Nauels A, Xia Y, Bex V, Midgley PM (2013) Summary for policymakers. Climate change, the physical science basis. Contribution of working group I to the fifth assessment report of the intergovernmental panel on climate change. Cambridge University Press, Cambridge, UK/New York. IPCC-XXVI/Doc.4
- Tashtoush FM, Al-Zubari WK, Shah A (2012) A review of the water–energy–food nexus measurement and management approach. *Int J Energy Water Resour* 3:1–14
- UN Water (2013) What is water security. Infographic, 8
- United Nation (UN) (2015) Transforming our world: the 2030 agenda for sustainable development resolution adopted by the general assembly. A/RES/70/1



- United Nation (UN) (2020) Report of the secretary-general on the 2019 climate action summit and the way forward in 2020. <https://www.un.org/en/climatechange>. Accessed June 2020
- Volk M (2014) Ecosystem services and river basin models: international conference. In: “Sustainability in the Water-Energy-Food Nexus” C03 Special Session: Ecosystems and their Services in the Nexus, May 19–20, 2014. Bonn
- Welsch M, Hermann S, Howells M, Rogner HH, Young C, Ramma I, Bazilian M, Fischer G, Alfstad T, Gielen D (2014) Adding value with CLEWS—modelling the energy system and its interdependencies for Mauritius. *Appl Energy* 113:1434–1445
- World Bank Group (WBG) (2016) Southern Africa energy-water nexus. Report no: ACS19178, World Bank

**Open Access** This chapter is licensed under the terms of the Creative Commons Attribution 4.0 International License (<http://creativecommons.org/licenses/by/4.0/>), which permits use, sharing, adaptation, distribution and reproduction in any medium or format, as long as you give appropriate credit to the original author(s) and the source, provide a link to the Creative Commons license and indicate if changes were made.

The images or other third party material in this chapter are included in the chapter's Creative Commons license, unless indicated otherwise in a credit line to the material. If material is not included in the chapter's Creative Commons license and your intended use is not permitted by statutory regulation or exceeds the permitted use, you will need to obtain permission directly from the copyright holder.





# Greenhouse Gases Emissions in Agricultural Systems and Climate Change Effects in Sub-Saharan Africa **54**

Winnie Ntinyari and Joseph P. Gweyi-Onyango

## Contents

Introduction .....	1082
The Approach Used .....	1084
Key Strategies for Reducing Greenhouse Gases Emissions and Mitigation of Climate Change .....	1084
Adopting Improved Nutrient Management in the Agricultural Lands .....	1084
Proper Management of Residue and Adoption of Appropriate Tillage Methods .....	1086
Introduction of Carbon-Sequestering Grass Species .....	1087
Livestock and Manure Management Strategies in SSA .....	1088
Adopting Bioenergy as GHG Emission Reduction Strategy .....	1092
Reduction of GHG Through Genetic Selection of Animals .....	1094
Adopting to Isotopic Tracers in the Agricultural Field .....	1094
Management of Emissions in Rice by Adoption of Efficient Varieties .....	1095
Development of Flexible Technology-Forcing Regulations .....	1096
Minimizing Enteric Fermentation and Food Wastes .....	1097
Use of Biochar to Minimize GHG Emissions .....	1097
Compositing of Solid Manure Before Applying to Crop Fields .....	1098
Integrated Farming Systems .....	1099
Barriers to Mitigation GHG Emission and Climate Change in Sub-Saharan Africa .....	1100
Need for More Research .....	1101
Conclusions .....	1102
References .....	1102

This chapter was previously published non-open access with exclusive rights reserved by the Publisher. It has been changed retrospectively to open access under a CC BY 4.0 license and the copyright holder is “The Author(s)”. For further details, please see the license information at the end of the chapter.

W. Ntinyari (✉) · J. P. Gweyi-Onyango  
Department of Agricultural Science and Technology, Kenyatta University, Nairobi, Kenya  
e-mail: [gweyi.joseph@ku.ac.ke](mailto:gweyi.joseph@ku.ac.ke)

---

**Abstract**

Climate change has been viewed to result from anthropogenic human activities that have significantly altered the Nitrogen (N) cycle and carbon cycles, increasing the risks of global warming and pollution. A key cause of global warming is the increase in greenhouse gas emissions including methane, nitrous oxide, and carbon among others. The context of this chapter is based on a comprehensive desktop review on published scientific papers on climate change, greenhouse emissions, agricultural fertilizer use, modeling and projections of greenhouse gases emissions. Interestingly, sub-Saharan Africa (SSA) has the least emissions of the greenhouses gases accounting for only 7% of the total world's emissions, implying that there is overall very little contribution yet it has the highest regional burden concerning climate change impacts. However, the values could be extremely higher than this due to lack of proper estimation and measurement tools in the region and therefore, caution needs to be taken early enough to avoid taking the trend currently experienced in developed nations. In SSA, agricultural production is the leading sector in emissions of N compound to the atmosphere followed by energy and transportation. The greatest challenge lies in the management of the two systems to ensure sufficiency in food production using more bioenergy hence less pollution. Integrating livestock and cropping systems is one strategy that can reduce methane emissions. Additionally, developing fertilizer use policy to improve management of fertilizer and organic manure have been potentially considered as effective in reducing the effects of agriculture activities on climate change and hence the main focus of the current chapter.

---

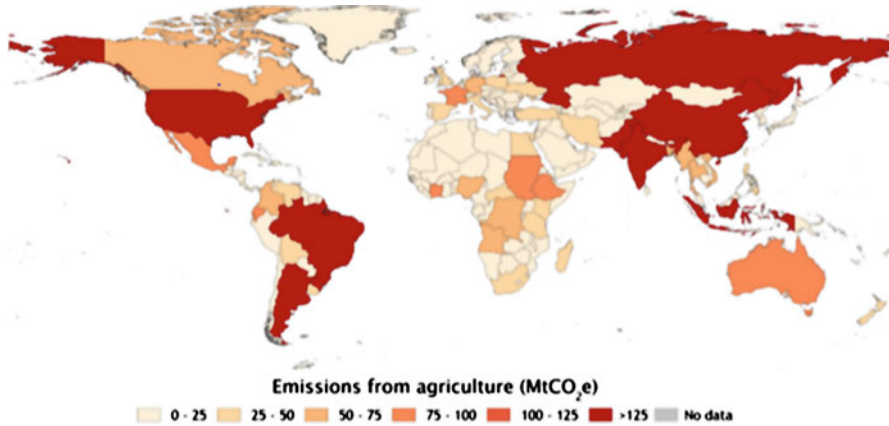
**Keywords**

Modeling · Pollution · Environment · Mitigation · Nitrous oxide · Carbon dioxide · Methane

---

**Introduction**

Globally, agriculture is the main contributor to greenhouse gases emissions (GHG) that is estimated to be between 10% and 20% of the total anthropogenic GHG emissions (Allen et al. 2020). From a baseline scenario, it is projected that GHG emissions from agriculture will be 1.7 gigatonnes by 2050. The GHG concentration especially CO<sub>2</sub> has increased by 40% since preindustrial times due to fossil fuels burning and also land-use changes. Current arable land cultivation practices have raised a great concern on the increase of GHG to the atmosphere. In sub-Saharan Africa, the effects are quite crucial but diverse as it has been associated with the variations of the season (rainy and dry) (Awazi and Tchamba 2019). As a result, this has significantly impacted the level of productivity, leading to food insecurity in this region. According to the US Environmental Protection Agency in 2010, the agricultural sector is the leading source of global GHG and accounts for 53% of carbon dioxide CO<sub>2</sub> emissions (Ronaghi et al. 2018). The distribution of CO<sub>2</sub> emissions is



**Fig. 1** Showing contribution of agriculture to GHG emission in global perspective. (Adapted from Malaka 2017)

globally spread as shown in Fig. 1, with most of sub-Saharan African countries emitting in the ranges of 0–75 MtCO<sub>2</sub>e.

The main four sources of emissions from the agricultural sector include cropland soil management, rice cultivation, ruminant livestock enteric fermentation, and livestock manure management (Beach et al. 2015). According to Tongwane and Moeletsi (2018), half of Africa’s total agricultural emissions were from enteric fermentation in 214 which signifies how great this source is. The GHG emissions in sub-Saharan Africa are estimated using Intergovernmental Panel on Climate Change guidelines in various subsystems of agriculture including crop production, animal manures, and methane emissions from livestock.

The main GHG fluxes from agricultural land include nitrous oxide (N<sub>2</sub>O), carbon dioxide (CO<sub>2</sub>), and methane (CH<sub>4</sub>). The emissions of these gases (CH<sub>4</sub>) and (N<sub>2</sub>O) in agricultural land have increased by 17% from 1990 to 2005 globally (Popp et al. 2010). It is also anticipated that the GHG emissions will increase soon due to modern land-use changes that the sub-Saharan Africa region has adopted (Popp et al. 2010). Although the fluxes are anticipated to be high, there are various uncertainties in the estimates provided due to large insufficient temporal and spatial representation of emissions from agricultural soils (Mwanake et al. 2019). In SSA, these changes have significantly impacted the climatic patterns leading to more extended droughts and excessive rainfall that does not support agricultural productivity at the field level. Furthermore, organic soils are important sources of GHG emissions with about 35 thousand Giga grams of CO<sub>2</sub> as of 2010 demonstrated in SSA (Malaka 2017). Though there is no clear quantification data, there no doubt that there are some emissions from due to lack of management of crop residues since most of the agricultural waste in the land is openly burned or left free for livestock grazing. The burning of savannas and grassland fires that is common with the sub-Saharan African region is another greater contributors to GHG emissions (Malaka 2017). Due to this huge contribution of GHG emissions to the ecosystems, agriculture becomes an integral part that SSA and the whole globe should focus on to stabilize the

emissions and save the current and future generations from the devastating effects of climate change. Therefore, this chapter will explore several available options and strategies that have the potential of mitigating GHG emissions from agriculture and minimize the impact of climate change.

---

## **The Approach Used**

To acquire information of this chapter, we used the Google Scholar search engine to identify relevant peer-reviewed research articles published in high impact journals. A total of 53 articles were used that ranged from experimental, reviews, and policy papers. Keywords used in Google Scholar search engine were sub-Saharan Africa, GHG, emissions, management of emissions from the agriculture sector, climate change, agricultural sectors, management, agricultural systems, modeling, emissions, and global warming. The chapter focused broadly on various methods that have been suggested by the global panel, policies, and guidelines of the Intergovernmental Panel on climate change.

---

## **Key Strategies for Reducing Greenhouse Gases Emissions and Mitigation of Climate Change**

### **Adopting Improved Nutrient Management in the Agricultural Lands**

In sub-Saharan Africa, there is a problem of declining nutrient levels in cultivatable land which is due to poor nutrient management among the farmers. Most of the farmers lack the know-how on efficient use of the available fertilizers with minimal N loss but with improved crop yield (Galloway et al. 2003). To achieve this, farmers should be enlightened through policies and extension on various ways of fertilizer use that minimize the extent of nutrient loss to the environment that contribute to emissions of gases such as nitrous oxide (Huang et al. 2019). Improvement of nutrient use efficiency has a high potential of minimizing the N<sub>2</sub>O emissions from cropland that are generally generated by the soil microbes from the surplus of N and indirect emissions from carbon dioxide from fertilizer companies (Galloway et al. 2003). Some of the recommended practices that farmers can adopt lie in the 4 R principle, which entails the use of the right source (fertilizer with higher efficiency), right rate, right timing, and right placement as expounded by Cassman et al. (2003). The proper placements of these fertilizers lead to fewer losses since there is a concomitant improvement in the plant uptake through making nutrients more accessible by the roots hence restricting available pathways for emissions. An important viable option for reducing losses is by reducing nitrification. Use of nitrification inhibitors for the case of nitrogen use is a promising strategy that has the huge potential of slowing the release processes that contribute to the formation of N<sub>2</sub>O emissions (Coskun et al. 2017). Use of improved crop varieties with higher N uptake and use efficiencies will lead to a reduction in the nutrient loss since such crop

idiotypes fully utilize the applied and available nutrient for use hence less losses in the form of GHG emissions (Sanz-Cobena et al. 2017).

Improved nutrient management is considered a better and viable strategy to overcome the challenges associated with the impacts of climate change in crop and food insecurities. According to García-Marco et al. (2016), adopting improved agronomic practices can lead to higher yields and promote the generation of more carbon that can be used to increase the soil carbon storage hence fewer losses to the environment. Some of the practices suggested by García-Marco et al. (2016) are extending crop rotations, use of improved varieties as mentioned earlier in this text, and using mixed cropping with perennial crops that will result to more carbon storage underground.

Emissions of GHG can also be reduced through practicing intensive cropping systems that minimize overreliance of pesticides and other agricultural inputs and consequently reduce the extent of emissions to the environment (Hoekman and Broch 2018). Besides, farmers/growers can use the cover crops that provide additional carbon to the soil and may help in extracting the available unused N by the next crops hence resulting to reduction of  $N_2O$  emissions (Oberthür et al. 2019). Use of Global Positioning Systems (GPS) guidance and variable rate technology are useful in applying inputs and hence allowing farmers to optimize nutrients with consequent less GHG emissions. In addition, the use of slow-release fertilizers such as prilled urea can be an efficient way of reducing  $N_2O$  emissions from cropland. Moreover, the use of biofertilizer has been advocated as an alternative to the more soluble and more reactive N sources as documented by excellent reviews by Ntinyari and Gweyi-Onyango (2018). Locally available nitrification inhibitors can also be useful in reducing the amount GHG from applied fertilizers to cropping systems. Soil pH management is also critical towards the management of  $N_2O$  emissions from the soil. Furthermore, the influence of pH on  $N_2O$  emissions more profound in soils that have high nitrate levels. According to the existing literature, pH contributes between 3 and 10 folds in incidences denitrification (Šimek and Cooper 2002). However, the good news is that use of liming in management of pH is something feasible among many farmers within sub-Saharan Africa if given fertilizer subsidies. Liming is a good option since is technically feasible and is affordable at a small scale levels. Nutrient use models are other useful tools in quantifying emissions from respective farms through the nutrient budget methods. These tools are key in estimating farm emissions by considering key components of nutrients inputs and nutrient outputs in given farms. In this case, it can be used to make a rough estimate of the amount of inputs required for specific crops to help in the reduction of emissions. Another option is the use and application of the soil systems budgets which record all the nutrient transformation related to emissions, for example, leaching, denitrification, and ammonia volatilization. This points to the fact that modeling tools are essential in linking the soil nutrients as well as a proxy resource for nutrient management and economic benefits to farmers.

Organic soils also need to be properly managed as they have the highest accumulation of carbon over the years. Avoiding row crops and tubers and deep ploughing using heavy machinery has been pointed out as one of the strategies that reduce the emissions of  $N_2O$  and  $CO_2$  (Smith et al. 2008). In sub-Saharan

Africa, a large fraction of the arable land has been degraded due to soil erosion, loss of organic matter, acidification, and other processes. These have to a greater extent affected the potential of the soil in holding/storing of carbon (Smith et al. 2008). Therefore, there is need for reclaiming land by application of organic substrates like manures, biosolids, reducing tillage, and leaving crop residues in the soils. With these practices in the farm, high nitrogen use efficiency is anticipated and this will minimize the emissions of  $N_2O$ .

### **Proper Management of Residue and Adoption of Appropriate Tillage Methods**

Advancing methods of weed control and machinery used in farming systems is another available way of reducing  $N_2O$  emissions from the soils. This is explained by the fact that soil disturbances tend to stimulate the soil carbon loss through enhanced erosion that result in soil carbon loss. However, the tillage method is dependent on the climatic conditions of the soils, considering that some reduced tillage options may have great effects of  $N_2O$  emissions from cropland (Feng et al. 2018). In tillage systems where growers/farmers retain crop residues, they tend to increase the soil carb since these residues act as precursors of soil organic matter which is a main store of carbon in soils. Mostly in the case where paddy crop growing is practiced, it has been found that no-tillage has a significant decrease in methane  $CH_4$  emissions. Furthermore, recycling of crop residues has been reported to be of help in preventing the release and/or deposition of aerosols and GHGs that are generated during burning (Feng et al. 2018). Biomass burning is always thought to be a key contributory factor to climate change since it releases methane in notable amounts. This is a common practice in Kano plains in Western Kenya under rice production. This implies that there is a need to manage fire concerning biomass burning in agricultural fields. Reducing biomass burning will also go a long way in minimizing the emissions of hydrocarbons and reactive nitrogen emissions that react to form tropospheric ozone (Leng et al. 2019). This is explained by the fact that smoke composes of aerosols which can have either warming or cooling effects of the atmosphere, hence directly or indirectly contributing to climate change. In this light, reducing the frequency of or the intensity of fires will contribute to landscape carbon density in soil and biomass. To minimize the emissions, mitigation of the radiant forcing is expected to entail fire suppression strategies such as reducing fuel load through vegetation management and also burning of biomass at the time of year when  $CH_4$  and  $N_2O$  are less emitted (Leng et al. 2019).

Crop rotation is advocated since it has given beneficial outcome through improving the quality of soils, with reported overall increment of as much 50% in terms of organic carbon into soils (Paustian et al. 2019). This practice creates resilience in cropping systems and helps the world to be able to combat climate change effects and hence can be a better option for SSA, where this is practiced already in noticeable scale. Through this approach, it is possible to sequester carbon for long-term storage of the atmospheric carbon. In this regard, this alternative offers the best solution to counter the greenhouse gases emissions in

the ecosystem. In addition, more yields are obtained from the cropping systems, which helps reduce the direct impacts of climate-related contributions to food insecurity. In soil management, there is also a need to bring in low-cost inhibitors that regulate nitrogen processes in the soils. However, this requires knowledge on the sources of the GHG using various soil microbial process that can help to bring mitigation of the same on board. Diversifying on the crop rotations will also provide another strategy to minimize GHG emissions from agriculture in SSA. Diversification of crops helps in improving the productivity in the different and diverse agro-ecosystems in SSA and also lower the carbon footprint. The choice of these crops can be guided depending on the ecological requirements in various growing zones within the region. Another option in minimizing emissions is through intensifying rotations in cropping systems through fallowing. Fallowing promotes nitrogen mineralization hence increasing available nitrogen for use by crops and minimize the amount of organic matter hence less carbon is stored in the soils. Most of the farmers prefer burning of various crop residues in their farms which contributes to climate change in various ways. It contributes to releases of GHGs like  $\text{CH}_4$  and also generates hydrocarbon and reactive nitrogen emissions that react to for tropospheric zones. Burning also destroys existing grass and also blackens the soil spoiling its quality and ability to sequester carbon. As a mitigation practice, farmers should rescue the frequency and the extent of fires for less  $\text{CH}_4$  and  $\text{N}_2\text{O}$  emissions (Smith et al. 2008).

## Introduction of Carbon-Sequestering Grass Species

Introduction of improved grasses that have a high level of production or with adaptations to C allocation to deeper roots has a great potential of increasing the soil carbon (Yang et al. 2019). For instance, using deep-rooted grasses in savannas has been associated with increased rates of carbon accrual hence less is emitted to the atmosphere. Cultivating of legumes into grazing lands has also been associated with the promotion of soil C storage and perhaps reduces  $\text{N}_2\text{O}$  emissions (Garnett et al. 2017). Grasses also act as cover crops that have long-term potential for reducing GHG emissions through agriculture that comes from agricultural activities. The grasses have the potential of absorbing and retaining stored carbon in the soil. The roots and shoots of cover crops feed bacteria, fungi, and earthworms and other soil organisms that have a significant contribution to the soil carbon levels over time. In the land that is left fallow, there is a need to convert the lands to grassland to sequester more carbon and create a balance of the carbon in the soils for a longer period. The most beneficial aspects of grassland are that they can stay longer without ploughing hence reducing emissions of  $\text{N}_2\text{O}$  from the soils. In grasslands, intensity grazing has an influence on the density of the grasses and allocation of carbon into the grass fields. It has been reported that carbon accrual on optimally grazed land has been often greater compared to ungrazed grasslands. Also, irrigation of grasslands has also high promotion of the soil carbon gains. Also alleviating deficiencies of nutrients in grassland through use of fertilizer or other organic amendments will promote carbon soil storage (Smith et al. 2008).



## Livestock and Manure Management Strategies in SSA

Livestock, specifically ruminants such as cattle and sheep, are important sources of CH<sub>4</sub> estimated to 18% of the global anthropogenic of this gas. In Table 1, there is a high chance of methane emissions that are more prevalent in the year 2000 compared with those likely to be there in the year 2030. These percentages represent a great share that needs to be mitigated using possible strategies that are available to the local farmers (Swamy and Bhattacharya 2006). According to the current statistics, the current population of livestock is anticipated to increase in 2030 based on the projections with sub-Saharan Africa, leading in the population as demonstrated in Fig. 2 (Herrero et al. 2008). This means that there is a need to come up with strategies for minimizing CH<sub>4</sub> from livestock systems. Some of the mitigation practices that can be used to reduce CH<sub>4</sub> emissions from livestock rearing include but not limited to improving the feeding practices. Feeding animals with more concentrates other than forages has been reported to reduce the rate of.

CH<sub>4</sub> for reducing. Other practices that can be used to minimize the level of CH<sub>4</sub> emissions are adding oils to the diet, as this is key in improving pasture quality since it improved animal productivity that reduces the proportion of energy lost as CH<sub>4</sub>. A high intake of protein feeds is also associated with reduced N<sub>2</sub>O emissions to the environment.

Another strategy of managing livestock methane emissions is the use of specific agents and dietary additives that can have the ability to suppress methanogenesis process. Some of the additives include Ionophores antibiotics that can minimize methane emissions in the livestock systems (Gibson 2002). Halogenated compounds inhibit methanogenic bacteria and their effects although they can have reduced feed intake. These have not yet been used extensively in SSA and have a huge potential of adopting. The bovine somatotropin (bST) and hormonal growth implants do not specifically suppress CH<sub>4</sub> formation, but by improving animal performance they can reduce emissions per kilogram of animal product (Cerri 2010), which is also another viable option. Adoption of longer-term management changes and animal breeding will enhance reduction of methane output per kilogram of an animal. With improved animal production efficiency, there are reduced lifetime emissions (Wall et al. 2010). Supplements can also be used in reducing methane emission in the livestock. Some of the supplements include oils, fats, tannins, probiotics, and marine algae. It has been reported that methane abatement between 10% and 25% is possible when feeding ruminants dietary oils. Also, plant secondary compounds like condensed tannins have proved to reduce methane production by 13–16% through curbing the process of methanogens.

Other available methane suppressers that are used in combating protozoal infections. Specialized proteins targeting methane-producing microbes will also constitute an effective alternative towards the management of emission from livestock. Moreover, plant saponins that occur naturally in many of the existing plant families have the potential to reduce methane and can be effective in the current measure towards minimizing the concentration of GHG in the atmosphere. Enteric methane emissions can be reduced through manipulation of the microbial communities in the

**Table 1** Methane emissions by domestic ruminants in different livestock production systems in Africa 2000–2030. (Adapted from Novak and Fiorelli 2010)

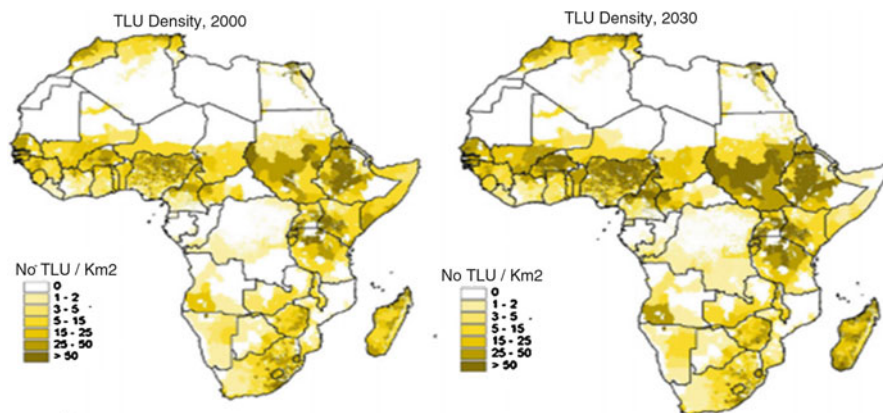
System <sup>a</sup>	2000			2030			Differences 2000–2030									
	Cattle <sup>b</sup>	Goats <sup>b</sup>	Sheep <sup>b</sup>	Total <sup>b</sup>	Methane/ km <sup>2b</sup>	Cattle <sup>b</sup>	Goats <sup>b</sup>	Sheep <sup>b</sup>	Total <sup>b</sup>	Methane/ km <sup>2c</sup>	Cattle <sup>c</sup>	Goats <sup>c</sup>	Sheep <sup>c</sup>	Total <sup>c</sup>	Methane km <sup>2c</sup>	
Livestock grazing																
Arid	1704.6	211.8	290.5	2206.9	123.6	2187.4	266.2	327.9	2781.5	157.3	0.28	0.26	0.13	0.26	0.26	0.27
Humid	217.7	24.6	14.6	256.9	179.5	261.1	29.4	14.9	305.4	318.8	0.20	0.20	0.02	0.19	0.78	0.78
Temperate	175.1	9.1	28.5	201.2	772.8	71.6	5.8	18.3	95.7	842.6	-0.59	-0.36	-0.36	-0.52	0.09	0.09
Total	2097.4	245.4	333.6	2665.0	136.3	2520.1	301.4	361.1	3182.7	169.7	0.20	0.23	0.08	0.19	0.24	0.24
Mixed																
Arid	2190.9	164.2	166.3	2521.5	650.6	4273.0	328.1	292.3	4893.4	986.5	0.95	1.00	0.76	0.94	0.52	0.52
Humid	494.2	71.9	38.9	605.1	427.5	804.0	160.8	71.0	1035.8	587.8	0.63	1.24	0.82	0.71	0.37	0.37
Temperate	1120.2	36.6	56.4	1213.2	1932.3	885.2	26.8	42.2	954.2	2958.2	-0.21	-0.27	-0.25	-0.21	0.53	0.53
Total	3805.3	272.8	261.7	4339.8	733.2	5962.2	515.7	405.5	6883.4	977.1	0.57	0.89	0.55	0.59	0.33	0.33
Other	451.0	49.0	41.9	541.9	135.3	614.6	79.3	62.7	756.7	203.5	0.36	0.62	0.50	0.40	0.50	0.50
Total methane from enteric fermentation	6353.7	567.3	637.1	7546.7	256.0	9097.0	896.5	829.3	10822.8	366.7	0.43	0.58	0.30	0.43	0.43	0.43
Total methane from manure	190.6	17.0	19.1	226.4	7.7	272.9	26.9	24.9	324.7	11.0	0.43	0.58	0.30	0.43	0.43	0.43
Total methane emissions for African domestic ruminants	6544.4	584.3	656.2	7773.1	263.7	9369.9	923.4	854.2	11147.5	377.7	0.43	0.58	0.30	0.43	0.43	0.43

(continued)

**Table 1** (continued)

System <sup>a</sup>	2000				2030				Differences 2000–2030							
	Cattle <sup>b</sup>	Goats <sup>b</sup>	Sheep <sup>b</sup>	Total <sup>b</sup>	Methane/ km <sup>2b</sup>	Cattle <sup>b</sup>	Goats <sup>b</sup>	Sheep <sup>b</sup>	Total <sup>b</sup>	Methane/ km <sup>2c</sup>	Cattle <sup>c</sup>	Goats <sup>c</sup>	Sheep <sup>c</sup>	Total <sup>c</sup>	Methane km <sup>2c</sup>	
By environment																
Arid	3895.5	376.1	456.8	4728.4	217.6	6460.5	594.3	620.2	7675.0	339.0	0.66	0.58	0.36	0.62	0.56	
Humid	711.9	96.5	96.5	861.9	302.9	1065.2	190.2	85.9	1341.2	493.1	0.50	0.97	0.60	0.56	0.63	
Temperate	1295.3	45.7	84.9	1414.4	1592.4	956.7	32.6	60.6	1049.9	2407.1	-0.26	-0.29	-0.29	-0.26	0.51	
Other	451.0	49.0	41.9	541.9	135.3	614.6	79.3	62.7	756.7	203.5	0.36	0.62	0.50	0.40	0.50	

<sup>a</sup>Methane from enteric fermentation<sup>b</sup>In million kg<sup>c</sup>As a proportion of 2000 values



**Fig. 2** Showing spatial distribution of livestock in Africa in the year 2000 and projected for 2030 (Herrero et al. 2008)

stomach of ruminants. This can be done through injecting/administering specific vaccines, drugs, or supplements that contribute to the reduction of methane. Other methods include; biological methods can be adopted to reduce the ability of the livestock to reduce methane production in domesticated animals. For instance, the virus that attacks microbes in the rumen of the ruminants can be used to ensure animals produce less GHG. Methanotrophs which are microbes can also be introduced in the animals to help in the breakdown of produced into other wastes. The bovine somatotropin and hormonal growth implants is also a possible option but it does not suppress methane formation but rather improved the general performance of animals hence minimizing the intensity of GHG.

Manure management should be given priority as it is associated with significant amounts of  $N_2O$  and  $CH_4$  during storage. However, the magnitude of the emissions varies depending on the structure. World over, there are no well-defined measures and policies of manure use and management since most of the grazing is done in open fields. For manure stored in lagoons or tanks, methane emissions can be minimized by covering or cooling of the sources. Other preliminary information has also suggested that covering manure heaps can significantly reduce  $N_2O$  emissions (Dennehy et al. 2017). In addition, emissions from manure can be curtailed by altering feeding practices and also precision application when it comes to cropland. Methane digesters/anaerobic digester can also be used as an alternative strategy to the reduction of GHG although it is expensive to install. This is since maintaining anaerobic digester requires basic knowledge in wastewater and electrical generation hence high investment costs that can be managed by respective governments. Adopting anaerobic digestion offers an excellent strategy towards the reduction of the  $CH_4$  and  $CO_2$  to the ecosystem. The process offers natural existing bacteria that decompose organic matter resulting in biogas (Wang et al. 2017). In return, the biogas can be used to burn fuel and reduce emissions of GHG from fossils. Other practices that need to be put into consideration include:

- Application placement (e.g., slurry injection)
- Application timing
- Application amounts (e.g., controlled rate systems)
- Export of manure (from the agricultural system)

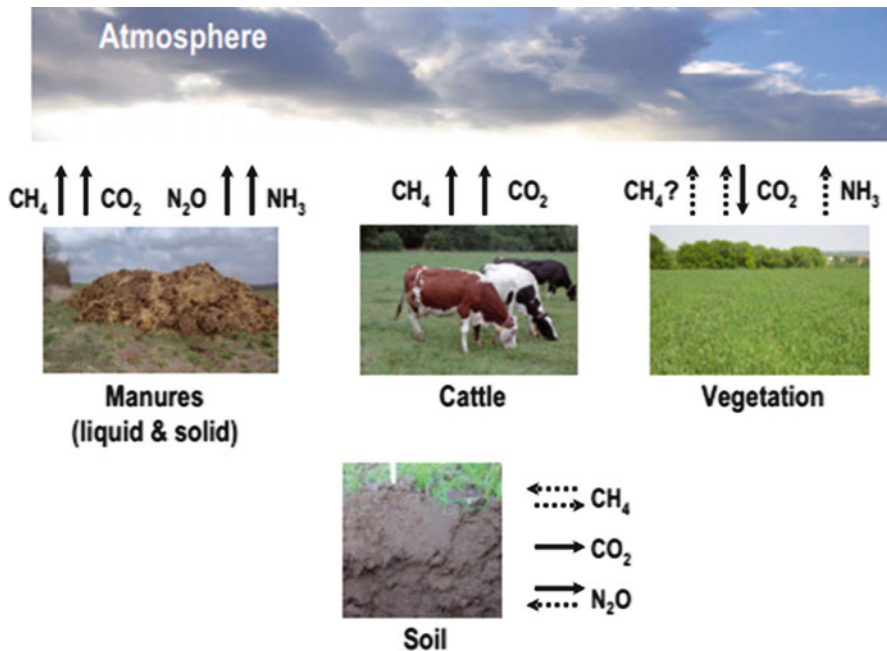
GHG models can be developed at whole-farm level approaches to help in mitigation of various emissions specifically from dairy farms. The advantage of using models in dairy farms is their ability to simulate calculations of CH<sub>4</sub> and N<sub>2</sub>O emissions although the models may considerably vary but they give information on the current and future trends upon application of given measures.

Following the Intergovernmental Panel on Climate Change standard emission factors, it is confirmed that nitrogen deposited from urine and feces is converted to nitrous oxide twice the rate from the fertilizers used in farms. From the projections done for 2050, it is shown clearly that that in open pasture method, if no mitigation is put into practice, there is a possibility of having 25% increment on the emissions. In open field grazing strategy, the farmers can use chemical nitrification inhibitors as a way of preventing the transformation of the nitrogen is excreted in urine and feces to nitrous oxide. The other option is the introduction of biological nitrification, for example, use of the *Brachiaria* grass that has been reported to generate almost zero N<sub>2</sub>O emissions. Therefore, this a grass that the breeders can focus on to have the particular trait transferred in mostly grown grasses in pastures fields (Fig. 3).

Use of methane digesters is another excellent successful strategy for consideration in SSA but will require government intervention especially in extending facilities from e large to small scale farmers to be able to encourage innovation. The respective governments should come into a collaboration to develop the most cost-effective technologies and this can be achieved through funded programs by innovators. In addition, there is a need to have programs that will enable early detection and remediation of leakages from digesters. The collected manure can also be used to make biogas which provides an additional source of renewable energy hence has higher chances of reducing GHG emissions. This is an economical method since it will save the farmers from using fossil fuels in cooking since they can generate power from their farms. It is also feasible to acidify slurry produced mostly in the zero-grazing sectors to enhance to reduce conversion and formation of methane.

## **Adopting Bioenergy as GHG Emission Reduction Strategy**

Crops and residues have high potential as sources of feedstocks for energy as a replacement of fossil fuels. Many of the materials that have been proposed for bioenergy role are grain, crop residue, cellulosic crops, and various tree species (Haberl et al. 2012). The advantage of these products is that they can be burned directly but later processed to generate fuel liquid. Although this process also produces CO<sub>2</sub>, it is associated with the original CO<sub>2</sub> from the atmosphere for the process of photosynthesis hence displaces the CO<sub>2</sub> that could be produced from fossils. The



**Fig. 3** Greenhouse gas and ammonia fluxes in the main compartments of a mixed crop-dairy system. (Adapted from Novak and Fiorelli 2010)

energy used in growing and processing the feedstock of bioenergy has a net benefit to the atmospheric CO<sub>2</sub> (Eloka-Eboka et al. 2019). The existing interaction of an expanding bioenergy sector land use and other ecosystems services such as food production has not been exploited potentially; for instance, through assessment modeling, sub-Saharan Africa has been listed as one of the promising regions for bioenergy. It is estimated that in 2050, 65% of the expected agricultural energy emissions will arise from farm energy use. In this regard, there is a need to reduce the amount of farm energy used from fossil to nonfossil use. Mitigation on the use of diesel fuels by tractors and other heavy equipment will be an effective move but requires transitions to hydrogen power that comes from solar and wind power. Also, battery-powered equipment and synthetic carbon-based fields will provide an alternative strategy. Use of these kinds of renewable energy in farms where mechanization is highly practiced will help in mitigating 85% of the total emissions from the synthesis of nitrogen fertilizers. Considering bioenergy as an option of mitigating GHG and saving our planet from climate change impacts, there is a need to make major transitions that are essential in exploiting the great potential of this particular source of energy (Smith et al. 2008). Bioenergy or use of biofuels implies a decrease in the dependence on fossil fuels and chemicals. The energy supplied from the use of plant-based fuels has the potential of decreasing GHG flow to the atmospheres. The biofuels will enable GHG mitigation through three key factors that include lower and

competitive prices compared to fossil energy sources, ease in their production since the plants are grown during the entire year, and ecological and economic benefits of biofuels due to their environmentally friendly nature. Through these strategies, it will be efficient in mitigation of climate change effects in sub-Saharan Africa, though this will take longer to be achieved compared to other considered options.

## **Reduction of GHG Through Genetic Selection of Animals**

Dairy is being one of the highest emitters of GHG to the atmosphere that requires critical strategies right from the selection of the best animals to reduce methane production. More focus should be put forward on the selection of cows that have less production of CH<sub>4</sub> per unit according to Table 2. The impact of increasing genetic potential of the production stock is to increase the daily live weight gain of livestock for meat production or by nutrition hence leading to reduction of methane product per unity of the product. However, faster growth for slaughter implies that more feed will be needed to meet the required weight within a short time (de Haas et al. 2017). Therefore, this also means that the genetic selection has also to consider the type of grasses that can meet the requirements of such animals within the set time.

A high growth genotype leads to low emissions hence providing a promising measure towards mitigation of the climate change as a result of concentration in the atmosphere (Martinez-Fernandez et al. 2018). In addition, the use of environmentally fit genotypes is fundamental to increasing efficiency of converting feed to beef. In an experiment conducted in a farm in Northern Territory, methane production was lower by 31% in per tonne of the weaned weight within a given time because of a genetic characteristic of animals that can be weaned early to reduce the total emissions in the livestock sector (Mottet et al. 2017).

## **Adopting to Isotopic Tracers in the Agricultural Field**

Stable isotopes that do not emit radiation such as nitrogen-15 and carbon 13 on small experimental fields are good options. This method allows then to analyze the efficiency of the crops to consume nitrogen and the accumulation of carbon in the soils. For instance, nitrogen-15 technique is widely used by scientist to track and advise farmers on the amount of chemical fertilizer/manure needed by the plants as one of the ways to reduce increased emissions to the ecosystems (Slaets et al. 2016). Nitrogen-15 isotopic techniques can also be used by scientist to identify the sources of nitrous oxide in production and this forms an important pathway of reducing the emission of the gas to the atmosphere. Therefore, this technique has the potential of measuring the impact of climate and provides a way of mitigation.

Carbon-13 has also been used in the assessment of the soil quality by identifying the content of organic sources of carbon in the soil. This is also a crucial favor in promoting the optimal application of the agricultural practices hence reducing GHG emission. Stable isotope can also be essential in the generation of information on

**Table 2** Feeding strategy and genetic selection in the management of GHG emissions. (Adapted from Novak and Fiorelli 2010)

Mitigation options for livestock management		CH <sub>4</sub>	N <sub>2</sub> O	CO <sub>2</sub>	NH <sub>3</sub>
Feeding strategy	Adding linseed lipids to the diet	↘?	–	–	–
	Increasing the proportion of concentrate in the diet	↘ from animals ↗ from slurry?	↗ or ↘? (from slurry <sup>a</sup> )	↗ (fossil energy + soil)	↗ or ↘? (from slurry <sup>a</sup> )
	Increasing the proportion of maize silage in the diet	↘ from animals	–	–	–
	Introducing legumes into grazed grasslands	↘	↗?	↘?	↗?
	Limiting excess N in the diet	↗?	↘	–	↘
Genetic selection	Selecting cows with low enteric	↘?	–	–	–
	CH <sub>4</sub> production				↘ <sup>b</sup> or ↗?
	Selecting high-yielding cows	↘ or ↗?	–	–	–
Herd characteristics	Reducing the replacement rate	↘?	–	–	↘
	Reducing the number of milking cows	↘	↘	↘	

<sup>a</sup>Depending on the N content of the concentrate compared to the roughage

<sup>b</sup>Results from Lovett et al. (2006)

↘: the mitigation option decrease the emissions

↗: the mitigation option increase the emissions

“↘ or ↗”: both tendencies have been shown

–: no information was given on this compound

0: studies have shown that this option had no significant effect on this compound.

?: the result needs to be confirmed by more studies.

GHG production and transport within a soil ecosystem. Importantly, stable isotopes have the potential of studying how GHG exchange with soils and atmosphere. This information is useful to enable researchers to understand the pathways of GHG, as well as the magnitude, as well as the magnitude is hence given rational recommendations (Zhu et al. 2019). However, this method is expensive and local farmers cannot afford to use to make various estimates. Therefore, the use of experimental reference sites can be useful in giving recommendations over a geographical position with similar activities.

## Management of Emissions in Rice by Adoption of Efficient Varieties

Rice production in flooded or paddy rice contributes to at least 10% of global agriculture production. There are various suggestions that have high technical



potential to mitigate rice emissions and that many of the options have a high potential of giving economic gains through yields and reduce the amount of water used in irrigation. Focusing on yield increase will give a promising measure towards reducing emission in rice production per unit area (Saha et al. 2018). This is in agreement with the FAO's forecast that increasing the rate of yield in paddy will also contribute to emission reduction in rice. Removing rice straws from paddies before reflooding to reduce methane production is also advised as one of the practices that farmers can embrace. The straws may be used for Bioenergy production (Joint 2018). Reducing the rate of flooding will reduce methane-producing bacteria where farmers can draw water down during the middle of the growing seasons. Another option is the breeding for rice varieties with lower emissions of methane in the systems. Experiments in other regions such as China and Japan have shown that drawdown can reduce methane emissions by up to 90% (Müller et al. 2016). Use of the system of Rice Intensification that aims at reducing irrigation water at farm-scale is also an adaptable technique that farmers can use to minimize methane emissions in their rice fields. In rice irrigation, farmers should be advised to reduce the duration of flooding to minimize the populations of the methane-producing bacteria. In this regard, rice can be planted in a dry field other than flooding them and also they can reduce water during the middle days of the growing season. Breeding of lower methane rice will be another strategy that researchers should focus on to introduce both upland and lowland rice-growing irrigation systems. Water management in irrigation through the expanding area on irrigation could be more effective in increased carbon storage in the soils. Draining of agricultural fields in humid regions will help in suppressing N<sub>2</sub>O emission through improved aeration in soils. This strategy has been used in other regions such as China and Japan since it also increases yield and saves on irrigation water hence can also be adopted for the sub-Saharan Africa region.

## **Development of Flexible Technology-Forcing Regulations**

The GHG emissions are strong issues that need to be regulated by the governments more so in sub-Saharan Africa counties where the governments have not invested much on controlling emissions due to their low-income capabilities. This is since if this issue remains a voluntary service, most of the individuals are not likely to take it as seriously as it is taken globally (Inglesi-Lotz and Dogan 2018). Therefore, there is a need to have flexible regulations that are designed to spur the technological development for the needed change. For instance, in case of fertilizer use, countries should develop regulatory systems that are similar to those developed in the United States or other places to increase the fuel efficiency of fleets of time (Nyamoga and Solberg 2019). Also, fertilizer manufacturers and importers will be required to sell fertilizers with increased efficiencies. Fertilizers regulation needed to be brought into consideration, for instance, the manufacturer should be barred from releasing any fertilizer product that does not have a coat to enhance its slow release and minimize N<sub>2</sub>O emissions in cropping systems.

## Minimizing Enteric Fermentation and Food Wastes

Enteric fermentation has the highest accountability of emissions from agriculture. It is part of the digestive systems of herbivorous animals that have a large four-compartment stomach with a complex microbial environment that enables it to digest complex carbohydrates. The process of digestion produced methane as a byproduct hence contributing to its accumulation in the atmosphere. In this regard when animals are kept for long, the more they produce methane, and therefore, this should be shortened and ensure the levels of methane per production unit are minimal (Owen and Silver 2015). The three main existing options to mitigate this kind of fermentation and emissions are

1. Improving the quality and digestibility of feed
2. Providing supplements and additives and reduce methane
3. Optimizing the health and reproductive capacity of the herds

Food and Agriculture Organization (FAO) has approximated that food wastes contribute to almost a third of the world's GHG. This is more so in sub-Saharan Africa due to the culture of people holding a social gathering with several types of edibles available hence providing a wide range of choice. These foods are potential sources of GHG emissions with key gases produced being carbon dioxide, methane, nitrous oxide, and hydrofluorocarbons especially in countries without any existing policies on food loss and waste management (Capone et al. 2016). This calls for the development of a monitoring framework for developing countries especially in sub-Saharan countries through installing simple tools that can be used in the traceability of GHG emissions. According to the Intergovernmental Panel on Climate Change (IPCC), the lowering of food wastes will help in reducing the rate of GHG emissions and concentration in the environment. In this regard, there is a requirement for the respective government to come up with policies and campaign to enlighten the locals on the need to reduce their food wastes as one of the factors for environmental sustainability and to alleviate the serious threats of climate change that are currently experienced (Edenhofer et al. 2011).

## Use of Biochar to Minimize GHG Emissions

Biochar is an organic material rich in carbon that is produced by the heating of biomass in the limited supply of oxygen. It is mainly produced as an additive to soils to improve nutrient retentions and carbon storage. In recent research, there has been growing interest in the use of biochar as an amendment to improve soil health, decrease net N<sub>2</sub>O emissions and methane, and to store carbon in the soils. Biochar has been recognized as one of the possible materials to enhance reduction of CO<sub>2</sub> concentration in the environment. The advantage of biochar is sufficiently used to reduce GHG emission in the atmosphere for a prolonged time. It also allows a net reduction on the emissions in the entire lifecycle including both direct and indirect

land uses (Kumar et al. 2020). It has been documented that biochar has the potential of reducing anthropogenic CO<sub>2</sub> in the atmosphere by 12%. Biochar has a low degradation process which helps in increasing its potential to store more carbon in the soils compared to other materials.

### **Compositing of Solid Manure Before Applying to Crop Fields**

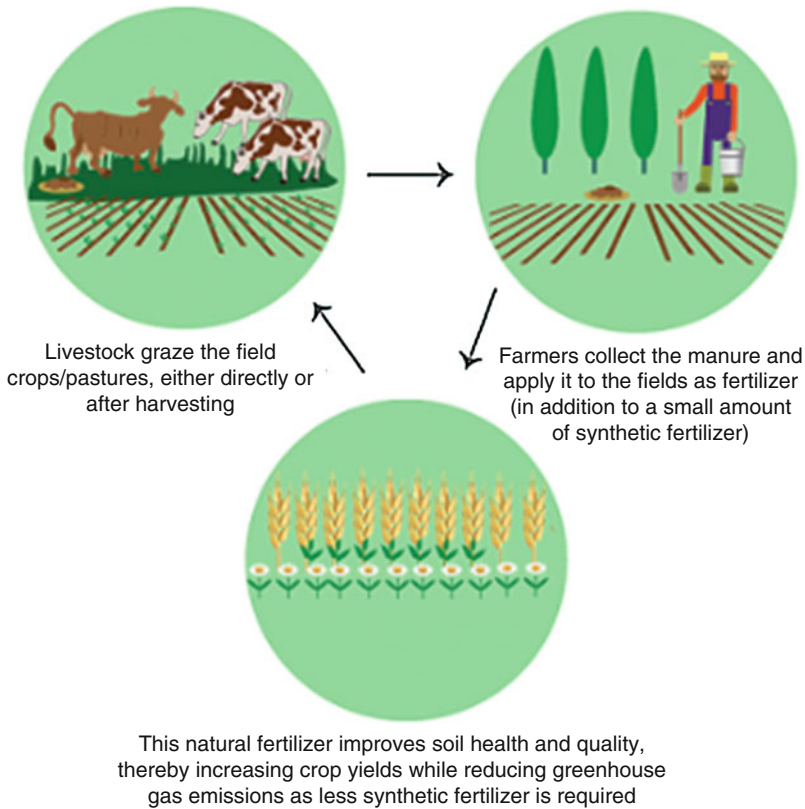
In many organic systems, composting of solid manure before applying to the field is encouraged. This method offers the advantage of producing a more stable product, free of weeds and toxins and easier to spread in the cropping systems. Through compositing it is subjects manure to the aerobic composition at temperatures of around 60 °C. Since this method requires frequent turning of the heaps, the method makes it more vulnerable for NH<sub>3</sub> losses; however, after application to the cropping fields, there are minimal losses since remaining N is mainly bound organically (Kumar et al. 2020). The mechanical turning of the composted manure is associated with lower N<sub>2</sub>O and CH<sub>4</sub> compared to the anaerobic method; hence, this should be considered for the whole management systems right from manure storage to supplication to soils in the fields. It has been estimated that compositing lowers N<sub>2</sub>O and CH<sub>4</sub> emissions; although significant amounts of CO<sub>2</sub> are emitted during the composting process, it is not considered as a net source of CO<sub>2</sub> in the entire agricultural chain. In addition, since composted manure is less degradable than fresh manure, application of this is a greater source of carbon storage in the soil and thus reduces the rate of CO<sub>2</sub> emissions. The rapid incorporation of manure in the soils as an improved technique of application is associated with fewer emissions and is more cost-effective (Joint 2018). This kind of incorporation should be done during the first hours after application. Through this method, a significant N<sub>2</sub>O emissions in the soils will be reduced. Farmers should also consider using farmyard manure over liquid slurry for reduced GHG emissions.

In crop production as agriculture, subsystem offers various mitigation of greenhouse gases specifically the CO<sub>2</sub> and N<sub>2</sub>O that are main gases in this level. The limitation of net CO<sub>2</sub> can be achieved through increasing the rate of carbon storage to soils or by the plant. This is achieved through slowing return of stored carbon into the atmosphere via mineralization (Stanton et al. 2018). Most importantly, N<sub>2</sub>O mitigation should focus specifically on improving the nitrogen use efficiency of crops since N<sub>2</sub>O is generated from the soils. In crop production, farmers should also avoid compacting during tillage since this may increase N<sub>2</sub>O emission due to the conducive environment created for anaerobic zones within the soil structures. During the incorporation of plant, farmers should be advised to use plant contents with low N content since high N content in the tissue will trigger mineralization and denitrification that can alleviate the levels of N<sub>2</sub>O emissions. Tackling the interlinked problems on land degradation, climate change mitigation is a promising strategy that can produce promising results for both farmers and government (Zerhusen et al. 2019).

## Integrated Farming Systems

The integrated farming system is another way to reduce GHG emission and promotes the fight against climate change. The integrated systems are based on nuclear techniques that have been put into practice in some counties within sub-Saharan Africa including Kenya and Uganda. The practices are aiming at maximizing the recycling of nutrients that are found in animal manure and crop residues. This will ensure there is a reduction in the chemical fertilizers use and this will enhance the reduction of GHG from agricultural land (Stanton et al. 2018). This is a practical strategy since farmers can recycle nutrients as livestock mainly feeds on herbs and grasses that are excreted in form of manure then farmers can collect the manure and apply in fields, which is a way of returning many nutrients into the soil as illustrated in Fig. 4.

This strategy is feasible and practically possible in sub-Saharan Africa since it has been applied in other regions and does not require high investment but rather involves a set of regulations and extension to enlighten farmers on the benefits of



**Fig. 4** Illustration of how an integrated system can reduce greenhouse gas emissions. (Adapted from Gamett 2011)

this process. Integrated cropping–livestock practices have been used in Brazil and have given a successful out management plan in the use of land more efficiently. As a result, the GHG emission from urine and dung was reported to reduce by 89% from respective farms. Polyculture is another agronomic practice that can be used to mitigate emissions of GHG and help in combating the adverse effects of climate change. Polyculture entails growing of multiple crops in the same space to increase local biodiversity and increase the soil carbon. Agroforestry is another agronomic practice that can be encouraged as a strategy to minimize GHG emission in agriculture. This practice entails integrating crops or livestock and trees either for timber, firewood, or any other wood products. The agroforestry provides buffer strips in the riparian land as well as increasing carbon stock in the soils since they increase carbon sequestration hence emissions of CO<sub>2</sub> to the atmosphere (Garnett 2011). Changes in consumption habits have substantial effects on the reduction of GHG emissions. Therefore, this calls for addressing how our food from agriculture is distributed across a supply chain. In particular, many of the environmental bodies have a recommended reduction of consumption of meat and other dairy products to enhance the reduction of GHG emissions from agricultural production. This implies that if consumers can adhere to this strategy and focus on well-grown crop products will have a significant effect on the overall concentration of GHG in the atmospheres. How this requires policy regulations and consumers' willingness to adapt to this kind of change. Although it is difficult to some communities that rear livestock as the main agricultural activity, they could be advised to minimize meat consumption, which may be from 5 to 2 days a week.

## **Barriers to Mitigation GHG Emission and Climate Change in Sub-Saharan Africa**

Although there are various opportunities to combat GHG emissions and reduce impacts of climate in Africa, there are key barriers that may hinder adoption and achievement of these goals. There is a challenge on lack of awareness among the farmers on the bottom line impacts of climate change and causes that emanate from their cropping-livestock systems. A great population of the farmers in sub-Saharan Africa are not aware of the existing option, either high or low cost. This is since there is less focus on the ground level to address the issue; in this regard mitigation of GHG and reducing the impact of climate change more focus on starting ground level for the change to experience. Moreso, there is the existence of unsureness about the practicality of the available measure among the leaders and activist of climate change actions; hence, less awareness has been created to date. There is also the existence of complex interactions as farmers do not know the bottom line of the unintended consequences on the complexity of interaction during the adoption of what is believed to make a change to GHG emissions from agriculture (Mehra et al. 2018). Regulations and policies are also other barriers towards adoption and application of the existing measure. Some of the verification and regulation are quite expensive, and the fact that sub-Saharan Africa is a low-income region confirms the

weight of the barrier. In addition, new regulatory regimes may require structuring the existing regulation before the implementation of proper governing policies.

Adopting some of the options may be against the social norms of the culture with diverse cultures being dominant in sub-Saharan Africa. For instance, manure management may be viewed as a dirty practice by some communities or religious beliefs hence making its management difficult. Besides, most farmers may fear loss aversion and may be adamant towards investing on best practices as advised by regulators. The existing extension services have the challenge of meeting farmers need and they create doubt on bits of advice they receive from them. Also, the government is slow in making clear on the role of extension officer and to what extent do they need to give communal seminars on critical issues such as climate change and GHG emissions (Allen et al. 2020). Development and transfer of technologies is another underlying barrier in the management of GHG emissions and mitigation of climate change. This is due to limited human and institutional capabilities to enhance proper dissemination of new information. Technological barriers exist in the limitation of generating and applying the developed solution to handle the problem. Technologies development and transfer remain crucial components for sustainable increase of productivity and mitigation of climate effects. Ecological barriers exist because mitigation potential in agriculture subsystems is mainly site-specific even within the same cropping systems. The limited resources in Sub-Saharan Africa pauses an ecological barrier towards management of GHG and climate changes impacts. The frequent drought in Africa may limit the exact measurement and application of the mitigation measures at the farm level. In addition, due to high levels of poverty in the region, there is a likelihood that affording good equipment for mitigation will be hard hence have to rely on donors from other regions.

---

## **Need for More Research**

Mitigation of GHG emissions is a critical area that currently requires a lot of investment in research, because these gases are complex and emitted from day to day activities that men perform to earn a daily living. Due to the adverse effects, they are causing damage to our ecosystems; identification of scientifically proven measures and option needs to be analyzed and scrutinized keenly through research. The researcher should focus more on agriculture although other sectors such as transport, energy, and industrialization have an equivalent measure. Although several measures have been documented to curb and minimize the rate of emissions, there is a need to have additional measures and strongly emphasize on their adoption through policy regulations. The research should focus on both generating new technologies and management systems with lower emission rates. Therefore, this requires the collaboration of governments in the sub-Saharan each to generate funds that can motivate and facilitate scientists in agricultural discipline to focus more on GHG about to actual quantification of the emissions as well as documenting available measures in the current context. Generation of more knowledge through research will provide cost-benefit analysis concepts to help in the assessment of the trade-off

in the climate change mitigation options (Garnett 2011). The discoveries through research will enhance the provision of information and rationale on taking actions to mitigate GHG emissions. In addition, it will form a basis on informing decision-makers and policymakers in the whole system.

---

## Conclusions

In the light of adverse climate change effects being experienced in sub-Saharan countries currently, several opportunities to mitigate GHG in agriculture exist and can be realized through overcoming several barriers. There is a need to assign mitigation measures on the key causes of climate change hence more emphasis on greenhouse gases emitted from agriculture. The key GHGs – CO<sub>2</sub>, N<sub>2</sub>O, and CH<sub>4</sub> – are not only produced in the farm setting but other sectors including energy, transport, and industries have a significant contribution. However, more potential lies in the agricultural sector that is widely spread in major regions of sub-Saharan Africa. Critical elements that require proper management are livestock systems and crop production that have shown to have the highest emission of the main GHG to the ecosystems. Therefore, to protect and improve the quality of our planet, there is a need to apply measures including manure management, improved fertilizer use efficiency, genetic selection of animals with less methane emission, minimizing enteric fermentation and floodwaters in agriculture and dairy subsystems. Developments of feasible and technological solutions to minimize GHG at small scale level, adopting bioenergy, growing of grass species with carbon sequestration effects, integrating crop-livestock system, and managing emission in paddy rice through proper use of irrigation water and biochar application among others. Putting all measures discussed in the current chapter will help reduce the impacts of climate change in sub-Saharan and improve the quality of air and environment health in general. Regardless of several feasible options existing to mitigate GHG emissions and climate change in agriculture, to achieve these measures, there is a need for collaborative efforts between governments and the locals to carry out the required ground activities. There is the existence of certain barriers that limit the potential of management. Some of these barriers include policy and regulation, inadequate human and institutional capabilities, unstructured extension services, fear of loss aversion among farmers, and absence of platforms for disseminating new technologies. For any of the above-discussed measure, decision-makers need to make a consideration to the extent to which it moves away or closer to making the environment safer and still maintaining sustainable agricultural production with less GHG emissions.

---

## References

- Allen J, Pascual KS, Romasanta RR, Van Trinh M, Van Thach T, Van Hung N, Chivenge P (2020) Rice straw management effects on greenhouse gas emissions and mitigation options. In: Sustainable rice straw management. Springer, Cham, pp 145–159
- Awazi NP, Tchamba MN (2019) Enhancing agricultural sustainability and productivity under changing climate conditions through improved agroforestry practices in smallholder farming systems in Sub-Saharan Africa. *Afr J Agric Res* 14(7):379–388

- Beach RH, Creason J, Ohrel SB, Ragnauth S, Ogle S, Li C, Salas W (2015) Global mitigation potential and costs of reducing agricultural non-CO<sub>2</sub> greenhouse gas emissions through 2030. *J Integr Environ Sci* 12(sup 1):87–105
- Capone R, Adriana C, Lee TKW (2016) Food losses and waste: global overview from a Mediterranean perspective. *Mediterra* 2016. Zero Waste in the Mediterranean. Natural Resources, Food and Knowledge/International Centre for Advanced Mediterranean Agronomic Studies (CIHEAM) and Food and Agriculture Organization of the United Nations (FAO)–Paris: Presses de Sciences Po, 193
- Cassman KG, Dobermann A, Walters DT, Yang H (2003) Meeting cereal demand while protecting natural resources and improving environmental quality. *Ann Rev Environ Resource* 28:315–358. <https://doi.org/10.1146/annurev.energy.28.040202.122858>
- Cerri C (2010) Management practices for greenhouse gas emission reduction and carbon removal in Brazilian agriculture, livestock and forestry. Centro de Energia Nuclear na Agricultura/Universidade de São Paulo, Piracicaba
- Coskun D, Britto DT, Shi W, Kronzucker HJ (2017) Nitrogen transformations in modern agriculture and the role of biological nitrification inhibition. *Nat Plants* 3(6):1–10
- de Haas Y, Pszczola M, Soyeurt H, Wall E, Lassen J (2017) Invited review: phenotypes to genetically reduce greenhouse gas emissions in dairying. *J Dairy Sci* 100(2):855–870
- Dennehy C, Lawlor PG, Jiang Y, Gardiner GE, Xie S, Nghiem LD, Zhan X (2017) Greenhouse gas emissions from different pig manure management techniques: a critical analysis. *Front Environ Sci Eng* 11(3):11
- Edenhofer O, Pichs-Madruga R, Sokona Y, Seyboth K, Kadner S, Zwickel T, Matschoss P (eds) (2011) Renewable energy sources and climate change mitigation: special report of the inter-governmental panel on climate change. Cambridge University Press, Cambridge, MA
- Eloka-Eboka AC, Bwapwa JK, Maroa S (2019) Biomass for CO<sub>2</sub> sequestration encyclopedia of renewable and sustainable materials; Elsevier Inc. All rights reserved. <https://doi.org/10.1016/B978-0-12-803581-8.11029-X>
- Feng J, Li F, Zhou X, Xu C, Ji L, Chen Z, Fang F (2018) Impact of agronomy practices on the effects of reduced tillage systems on CH<sub>4</sub> and N<sub>2</sub>O emissions from agricultural fields: a global meta-analysis. *PLoS One* 13(5):e0196703
- Galloway JN, Aber JD, Erisman JW, Seitzinger SP, Howarth RW, Cowling EB, Cosby BJ (2003) The nitrogen cascade. *Bioscience* 53:341–356. [https://doi.org/10.1641/0006-3568\(2003\)053\[0341:TNC\]2.0.CO;2](https://doi.org/10.1641/0006-3568(2003)053[0341:TNC]2.0.CO;2)
- García-Marco S, Abalos D, Espejo R, Vallejo A, Mariscal-Sancho I (2016) No-tillage and liming reduce greenhouse gas emissions from poorly drained agricultural soils in Mediterranean regions. *Sci Total Environ* 566:512–520
- Garnett T (2011) Where are the best opportunities for reducing greenhouse gas emissions in the food system (including the food chain)? *Food Policy* 36:S23–S32
- Garnett T, Godde C, Muller A, Röös E, Smith P, De Boer IJM, Van Zanten HHE (2017) Grazed and confused?: ruminating on cattle, grazing systems, methane, nitrous oxide, the soil carbon sequestration question-and what it all means for greenhouse gas emissions. FCRN, Oxford
- Gibson AI (2002) Mitigation options for greenhouse gas emissions from agriculture. University of London, London
- Haberl H, Sprinz D, Bonazountas M, Cocco P, Desaubies Y, Henze M, Lange E (2012) Correcting a fundamental error in greenhouse gas accounting related to bioenergy. *Energy Policy* 45:18–23
- Herrero M, Thornton PK, Kruska R, Reid RS (2008) Systems dynamics and the spatial distribution of methane emissions from African domestic ruminants to 2030. *Agric Ecosyst Environ* 126(1–2):122–137
- Hoekman SK, Broch A (2018) Environmental implications of higher ethanol production and use in the US: a literature review. Part II–biodiversity, land-use change, GHG emissions, and sustainability. *Renew Sust Energ Rev* 81:3159–3177
- Huang R, Wang Y, Liu J, Li J, Xu G, Luo M, Gao M (2019) Variation in N<sub>2</sub>O emission and N<sub>2</sub>O related microbial functional genes in straw-and biochar-amended and non-amended soils. *Appl Soil Ecol* 137:57–68



- Inglesi-Lotz R, Dogan E (2018) The role of renewable versus non-renewable energy to the level of CO<sub>2</sub> emissions: a panel analysis of sub-Saharan Africa's Big 10 electricity generators. *Renew Energy* 123:36–43
- Joint FAO (2018) Rice production guidelines: best farm management practices and the role of isotopic techniques (No. IAEA-TECDOC-1847). Joint FAO/IAEA Division of Nuclear Techniques in Food and Agriculture
- Kumar S, Meena RS, Datta R, Verma SK, Yadav GS, Pradhan G, . . . Mashuk HA (2020) Legumes for carbon and nitrogen cycling: an organic approach. In: Carbon and nitrogen cycling in soil. Springer, Singapore, pp 337–375
- Leng LY, Ahmed OH, Jalloh MB (2019) A brief review on climate change and tropical peatlands. *Geosci Front* 10(2):373–380
- Lovett DK, Shalloo L, Horan B, Dillon P, O'Mara FP (2006) Effect of Holstein–Friesian strain and feeding system on greenhouse gas emissions from pastoral dairy production systems. In: International Congress Series, vol 1293. Elsevier, pp 335–338
- Malaka SF (2017) Estimation of greenhouse gas emissions from agriculture in the eastern Free State, South Africa (Doctoral dissertation, University of the Free State)
- Martinez-Fernandez G, Duval S, Kindermann M, Schirra HJ, Denman SE, McSweeney CS (2018) 3-NOP vs. halogenated compound: methane production, ruminal fermentation and microbial community response in forage-fed cattle. *Front Microbiol* 9:1582
- Mehra P, Baker J, Sojka RE, Bolan N, Desbiolles J, Kirkham MB, Gupta R (2018) A review of tillage practices and their potential to impact the soil carbon dynamics. In: Advances in agronomy, vol 150. Academic Press, pp 185–230
- Mottet A, Henderson B, Opio C, Falcucci A, Tempio G, Silvestri S, Gerber PJ (2017) Climate change mitigation and productivity gains in livestock supply chains: insights from regional case studies. *Reg Environ Chang* 17(1):129–141
- Müller A, Bautzen L, Meier M, Gättinger A, Gall E, Chatzinikolaou E, Ullmann L (2016) Organic farming, climate change mitigation and beyond. Reducing the environmental impacts of EU agriculture. IFOAM EU, Brussels
- Mwanake RM, Gettel GM, Aho KS, Namwaya DW, Masese FO, Butterbach-Bahl K, Raymond PA (2019) Land use, not stream order, controls N<sub>2</sub>O concentration and flux in the upper Mara River basin, Kenya. *J Geophys Res Biogeo* 124(11):3491–3506
- Novak SM, Fiorelli JL (2010) Greenhouse gases and ammonia emissions from organic mixed crop-dairy systems: a critical review of mitigation options. *Agron Sustain Dev* 30(2):215–236
- Nyamoga GZ, Solberg B (2019) A review of studies related to charcoal production, consumption, and greenhouse gas emissions in Tanzania. In: Agriculture and ecosystem resilience in Sub Saharan Africa. Springer, Cham, pp 357–399
- Oberthür S, Hermwille L, Khandekar G, Obergassel W, Rayner T, Wyns T, and Melkie M (2019) Key concepts, core challenges and governance functions of international climate governance: deliverable 4.1; COP21-results and implications for pathways and policies for low emissions European societies
- Owen JJ, Silver WL (2015) Greenhouse gas emissions from dairy manure management: a review of field-based studies. *Glob Chang Biol* 21(2):550–565
- Paustian K, Larson E, Kent J, Marx E, Swan A (2019) Soil C sequestration as a biological negative emission strategy. *Front Clim* 1(8):1–11
- Popp A, Lotze-Campen H, Bodirsky B (2010) Food consumption, diet shifts and associated non-CO<sub>2</sub> greenhouse gases from agricultural production. *Glob Environ Chang* 20(3):451–462
- Ronaghi M, Saghalian S, Reed M, Mohammadi H (2018) The impact of the agricultural sector in developing countries that produce natural gas on greenhouse gas emissions. *Int J Food Agric Econ (IJFAEC)* 6(1128–2019-555):53–69
- Saha S, Chatterjee D, Swain CK, Nayak AK (2018) Methane emission from wetland rice agriculture-biogeochemistry and environmental controls in projected changing environment. In: Advances in crop environment interaction. Springer, Singapore, pp 51–85

- Sanz-Cobena A, Lassaletta L, Aguilera E, Del Prado A, Garnier J, Billen G, Plaza-Bonilla D (2017) Strategies for greenhouse gas emissions mitigation in Mediterranean agriculture: a review. *Agric Ecosyst Environ* 238:5–24
- Šimek M, Cooper JE (2002) The influence of soil pH on nitrification: progress towards the understanding of this interaction over the last 50 years. *Eur J Soil Sci* 53:345–354
- Slaets J, Mayr L, Heiling M, Zaman M, Resch C, Weltin G, Dercon G (2016) Protocol development for continuous nitrogen-15 measurement of N<sub>2</sub>O and its isotopomers for real-time greenhouse gas tracing
- Smith P, Martino D, Cai Z, Gwary D, Janzen H, Kumar P, Scholes B (2008) Greenhouse gas mitigation in agriculture. *Philos Trans R Soc B Biol Sci* 363(1492):789–813
- Stanton CY, Mach KJ, Turner PA, Lalonde SJ, Sanchez DL, Field CB (2018) Managing cropland and rangeland for climate mitigation: an expert elicitation on soil carbon in California. *Climatic Change* 147(3–4):633–646
- Swamy M, Bhattacharya S (2006) Budgeting anthropogenic greenhouse gas emission from Indian livestock using country-specific emission coefficients. *Curr Sci*:1340–1353
- Tongwane MI, Moeletsi ME (2018) A review of greenhouse gas emissions from the agriculture sector in Africa. *Agric Syst* 166:124–134
- Wall E, Simm G, Moran D (2010) Developing breeding schemes to assist mitigation of greenhouse gas emissions. *Animal* 4(3):366–376
- Wang Y, Dong H, Zhu Z, Gerber PJ, Xin H, Smith P, Chadwick D (2017) Mitigating greenhouse gas and ammonia emissions from swine manure management: a system analysis. *Environ Sci Technol* 51(8):4503–4511
- Winnie N, Gweyi-Onyango J (2018) Biofertilizers as an alternative to inorganic fertilizers in sub-Saharan African: is the adoption the missing link? *Elixir Agric* 114:49564–49551
- Yang Y, Tilman D, Furey G, Lehman C (2019) Soil carbon sequestration accelerated by the restoration of grassland biodiversity. *Nat Commun* 10(1):1–7
- Zerhusen B, Maze M, Effenberger M (2019) Hands-on model for assessing the green-house gas emissions and the fossil energy consumption of agricultural biogas plants. *Landtechnik* 74(5):118–134
- Zhu XC, Di DR, Ma MG, Shi WY (2019) Stable isotopes in greenhouse gases from soil: a review of theory and application. *Atmosphere* 10(7):377

**Open Access** This chapter is licensed under the terms of the Creative Commons Attribution 4.0 International License (<http://creativecommons.org/licenses/by/4.0/>), which permits use, sharing, adaptation, distribution and reproduction in any medium or format, as long as you give appropriate credit to the original author(s) and the source, provide a link to the Creative Commons license and indicate if changes were made.

The images or other third party material in this chapter are included in the chapter's Creative Commons license, unless indicated otherwise in a credit line to the material. If material is not included in the chapter's Creative Commons license and your intended use is not permitted by statutory regulation or exceeds the permitted use, you will need to obtain permission directly from the copyright holder.





# Use and Impact of Artificial Intelligence on Climate Change Adaptation in Africa

# 55

Isaac Rutenberg, Arthur Gwagwa, and Melissa Omino

## Contents

Introduction .....	1108
Scoping AI in Africa .....	1110
Case Studies of General Applications of AI in Africa .....	1111
Review of African AI Focusing on Climate Change Issues .....	1113
Geospatial Technologies .....	1114
The Private Sector, and Converging Exponential Technologies .....	1116
University Activity .....	1118
The Potential of AI .....	1119
Challenges and Future Applications .....	1119
Scope of the Problem .....	1119
Ethical Issues of Predicting Climate Change Impacts .....	1120
Data Inadequacies .....	1121
Conclusions .....	1122
References .....	1122

## Abstract

Although Climate Change is a global phenomenon, the impact in Africa is anticipated to be greater than in many other parts of the world. This expectation is supported by many factors, including the relatively low shock tolerance of many African countries and the relatively high percentage of African workers engaged in the agricultural sector. High-income countries are increasingly turning their focus to climate change adaptation, and Artificial

---

This chapter was previously published non-open access with exclusive rights reserved by the Publisher. It has been changed retrospectively to open access under a CC BY 4.0 license and the copyright holder is “The Author(s)”. For further details, please see the license information at the end of the chapter.

---

I. Rutenberg (✉) · A. Gwagwa · M. Omino  
CIPIT, Strathmore University, Nairobi, Kenya  
e-mail: [irutenberg@strathmore.edu](mailto:irutenberg@strathmore.edu)

Intelligence (AI) is a critical tool in those efforts. Algorithms using AI are making better predictions on the short- and long-term effects of climate change, including predictions related to weather patterns, floods and droughts, and human migration patterns. It is not clear, however, that Africa is (or will be) maximally benefitting from those AI tools, particularly since they are largely developed by highly developed countries using data sets that are specific to those same countries. It is therefore important to characterize the efforts underway to use AI in a way that specifically benefits Africa in climate change adaptation. These efforts include projects undertaken physically in Africa as well as those that have Africa as their focus. In exploring AI projects in or about Africa, this chapter also looks at the sufficiency of such efforts and the variety of approaches taken by researchers working with AI to address climate change in Africa.

---

**Keywords**

Africa · Climate change · Artificial intelligence · Algorithms · Data · Adaptation · Migration

---

**Introduction**

The deepest roots of climate change begin with the second industrial revolution and the widespread adoption of fossil fuel-based machinery. As the world enters the fourth industrial revolution, the adoption of advanced technologies such as artificial intelligence (AI) introduces complex challenges and opportunities for the now-inevitable and as-yet-undetermined issues of climate change. This chapter explores those challenges and opportunities, and whether or to what extent the fourth industrial revolution will enhance Africa's ability to cope with climate change.

Technologies associated with the fourth industrial revolution (4IR) include blockchain, the Internet of things (IoT), artificial intelligence, cloud computing, quantum computing, advanced wireless communications, and 3D printing, among others. Although these technologies are, at times and in various ways, interrelated, this chapter focuses mainly on AI and the impact that it will have on Africa's ability to cope with climate change. This focus is not, however, meant to imply that other 4IR technologies will not be important. Indeed, some technologies such as the widespread connectivity of sensors that accompany the development of IoT will likely have substantial positive impact on the ability of African nations to gather useful data. An example of this is Upepo Technologies, described below, that is using IoT devices to monitor water distribution points throughout Kenya. Other technologies may have mixed or negative impact: cryptocurrencies based on blockchain technology have so far increased the amount of energy used worldwide by computers, and advanced communications technologies are projected to account for 20% of global energy demand by 2025 (The Guardian 2017). Any increase in energy demand has a negative effect on climate change. Surely these technologies will continue to evolve, and Africans' ability to predict their ultimate impacts is limited.

AI has probably been postulated for longer than any other 4IR technology, but has remained impractical until the recent decade. Although a variety of forms of AI are known and being pursued in various contexts and by various private- and public-sector stakeholders, this chapter is largely confined to discussing AI as a tool for processing large amounts of data and improving predictions from those data.

Predictive algorithms using AI are available to entrepreneurs using two main pathways. The first is by using and adapting widely available open source algorithms. Many of the global technology companies have released suites of AI tools on open source licenses, including Google, Microsoft, and IBM. The alternative pathway is to develop, test, and train novel algorithms. Examples of companies following each of these pathways, as well as combinations thereof, can be readily identified, particularly (but not exclusively) in the high technology hubs of Lagos, Nairobi, and Johannesburg.

Developing the algorithms is, however, only one part of a larger process of integrating AI into products and processes. Effective predictive algorithms using AI rely on three main components: fast computers, large datasets, and abundant human labor (The Economist 2020). The need for fast computers is obvious, and suitable computing power is relatively abundantly available, even if Africa is perpetually and conspicuously absent from international lists of supercomputers (TOP500.org 2019). Human labor is needed in order to label data, as AI algorithms require accurately labelled data in order to learn and increase the accuracy of predictions. Africa has an abundance of labor, including large numbers of unemployed or underemployed youth that have sufficient computer skills, and is therefore ideally positioned for performing this task. For example, Samasource is a data annotation provider with a major presence in Kenya and Uganda. Using a hybrid structure involving both for-profit and nonprofit entities, Samasource provides data labelling services for Fortune 500 companies employing AI systems, while simultaneously seeking to reduce poverty through job creation.

This leaves three factors that are particularly interesting in the African context: the availability of sufficiently large datasets, the suitability of the algorithms themselves; and the creativity of developers, entrepreneurs, and others in applying AI in the creation of new products, services, and solutions. The three factors of interest are interrelated, and it is difficult to assess any one factor in isolation. AI is a multi-purpose tool, but the output of any given AI product is as much or more dependent upon the dataset as on the specific AI algorithm. Regardless of the algorithms, the availability of high quality, locally relevant datasets is likely to be extremely important for AI to be of any use to the fight against climate change. Furthermore, since the bulk of AI development has so far been from outside the African continent, the creativity and effort of developers and their collaborators are also critical to the contribution of AI. Accordingly, the second (datasets) and third (applications) factors are the subject of this chapter.

Part I of this chapter introduced the topic and framed the research question. Part II broadly and briefly review the state of AI research and development in Africa, as well as global AI research that is relevant or targeted at Africa. Part III narrows the focus and explore African AI products and research that are specific to the issues of Climate Change. Such issues include weather prediction, agriculture, floods and drought, and

human migration. The chapter concludes in Part IV, with a look at particular challenges and potential future applications of AI in the area of climate change.

---

## Scoping AI in Africa

It is easy to get the impression that there is little or no activity in AI research and development in Africa. In report after report, African countries are either characterized as poorly performing or are completely absent from the analysis. African governments score very low in their perceived readiness to “take advantage of the benefits of AI in their operations and delivery of public services” (Oxford Insights International Development Research Centre 2019). In that global index, no African government ranked within the top 50 governments. In a broader index covering 54 countries over seven factors (Talent, Infrastructure, Operating Environment, Research, Development, Government Strategy and Commercial Ventures), all six African countries that were part of the study ranked in the bottom quartile (Tortoise Intelligence 2019). In an even broader analysis using different datasets to “comprehensively assess the state of AI R&D activities around the world,” the African region was ranked at or near the bottom of nearly every measure and ranking (Perrault et al. 2019). This included measurements such as AI papers published and cited, AI-focused patents, conferences, and technical performance. The picture painted by these global indices is one of virtually no activity and a gloomy outlook for future activity.

As is often the case, however, the global indices are not necessarily good measures of activity on the African continent. Activities by African governments and certain other entities are often not reported or described online. Activities in the private sector may be minimal when compared to activity levels in developed countries, but the comparison is not particularly useful. As shown by the examples provided below, the R&D that is carried out is meaningful and a significant part of the overall research environment on the continent.

African-hosted conferences on AI showcase African-led and Africa-focused AI R&D and demonstrate the breadth of such work. The Deep Learning Indaba, which began in 2017, is such an example; devoted entirely to African AI R&D, it has doubled attendance each of the following 2 years. The yearly event has created great interest, and in 2018, 13 mini-conferences (referred to as “IndabaX” conferences) were held in as many countries in Africa. Such conferences are important for the normal reasons, but also because African researchers have particular difficulties attending AI conferences in other parts of the world. African nationals are routinely denied visas to attend international conferences (Knight 2019). The challenges faced by African nationals is significant enough that the International Conference on Learning Representations, a major AI conference, elected to hold the 2020 conference in Africa. This decision was intended to enable greater African participation (Johnson 2018).

Meanwhile, global technology companies are turning some of the focus of their AI R&D on Africa. Google opened an AI development laboratory in Ghana in 2019. Microsoft published a whitepaper focusing on the importance of AI research in Africa (Microsoft Access Partnership University of Pretoria 2018). A significant

body of technological developments have been produced by IBM researchers at the IBM laboratory in Nairobi (Weldemariam et al. 2020). Motivations for global technology companies to work in Africa include, among others, the reduction of bias by increasing diversity in the researchers and the context in which they work (Adeoye 2019).

## Case Studies of General Applications of AI in Africa

Academic and private sector AI researchers in Africa seek to apply AI to a wide variety of topics, some of which are directly relevant to climate change, and others are relevant inasmuch as they advance the general state of AI. A particularly important topic is bioinformatics and genomics (Diallo et al. 2019). Significant biodiversity exists on the African continent, and much of it is understudied relative to other regions (Campbell and Tishkoff 2008). The application of AI algorithms, with its ability to analyze large datasets, is particularly appropriate in the area of genomics. Even where the work is not specifically addressing issues directly related to climate change, a better understanding of bioinformatics and genomics will support biodiversity and our ability to encourage genetic resistance to environmental shocks.

Another topic of interest to African AI researchers is farming. The importance and vulnerability of farming on the African continent cannot be overstated. More than 50% of the entire African workforce is employed in agriculture, yet most of that activity is at the subsistence level (Alliance for a Green Revolution in Africa (AGRA) 2014). Approximately 80% of all farms in Sub-Saharan Africa are smallholder farms where 175 million people are directly employed. Modern farming methods such as large-scale mechanized harvesting, irrigation, and crop rotation are less common, meaning that African agriculture is more susceptible to weather and labor shocks. Traditional African crops are under threat from global seed companies seeking to dominate the African market (Scoones and Thompson 2011). Deforestation and overgrazing threaten African soil, but productive farmland is targeted by foreign governments and companies seeking new resources to enhance food security (The World Bank 2014).

It is anticipated that predictive analytics, aided by machine learning, will significantly improve overall output by the African farming sector (Alliance for a Green Revolution in Africa (AGRA) 2014). The cornerstone of successful AI is sufficient data, and in this area, Africa is relatively well positioned. Datasets pertaining to agriculture are available from a variety of sources, as the subject of African agriculture has been of intense interest to both local and international stakeholders for many decades. These datasets include actual measurement data as well as predictive or extrapolative datasets, as well as combinations thereof (African Soil Information Service). Improving the quantity and quality of data, and encouraging wider and more effective use of Big Data, is the focus of research by Patrick MacSharry at the Carnegie Mellon University campus in Kigali, Rwanda. Numerous other academic researchers are also contributing to the push toward effective incorporation of data science in African agriculture.

Successful agriculture requires more than land, seeds, and suitable weather. Crop diseases and infestations of plant pests are significant threats to global agriculture and are particularly dangerous to agriculture in Africa. For example, invasions of the desert locust can last for up to a decade, and can cause widespread food shortages of catastrophic proportions (Lecoq 2003). Similarly, strains of wheat rust such as ug99, which originated in Uganda, are considered a global threat as well as a threat to African agriculture (Aydoğdu and Boyraz 2012). An ability to diagnose crop diseases is therefore critical, and local and global technology industries have taken notice. Mobile phone applications that allow farmers to diagnose crop disease or identify the presence of crop pests are proliferating (Nzouankeu 2019). Considering that many plant diseases and crop pests are highly geographically specific, local development of technology solutions to these problems is a prerequisite to their success, and the African technology industry is beginning to address this need.

Looking beyond agriculture, financial institutions in Africa are not often at the forefront of widespread introduction and adoption of technology. Notwithstanding the success of mobile banking (which more properly attributes success to the fact that it originated from the telecom industry rather than the banking industry), traditional financial institutions have been slow to adopt technologies such as online banking. This is not necessarily only due to resistance within the African banking sector, but is also due to the relatively low level of access to technology by banking customers. Nevertheless, nearly every industry sector in Africa is affected by the availability (or absence) of credit and the presence (or absence) of financial institutions. Financial technologies, referred to as “fintech,” are a particularly active area of the incorporation of AI into products and services. A common use of AI in fintech is in the determination of creditworthiness. Although not discussed here, it is worth noting that such applications have been criticized for a variety of reasons, ranging from data protection issues to exacerbation of inequality (Johnson et al. 2019). Traditional and nontraditional banking institutions can make use of larger datasets from a broader list of sources in order to determine the risk of extending credit to individual or institutional customers. This is particularly useful in a region where formal credit histories are relatively rare or based on very limited data. Another fintech product that is gaining traction with African financial institutions is the use of AI to evaluate customer behavior. Behavior analysis can be used to improve predictions of suitable financial products, thus allowing institutions to focus their marketing efforts and improve efficiencies.

Raising capital to support product development and market expansion is a necessary component of the modern technology industry. There is significant evidence that success at attracting investor attention in Africa is due to a variety of factors, including some factors that are not related to the quality or appropriateness of the technology (Peacock and Mungai 2019). Nevertheless, some African startups have raised significant capital for the application of AI to agriculture, fintech, and mobility solutions, among other uses of AI. In South Africa, Aerobotics is a company that is developing a digital platform for using AI to interpret data gathered by drones and satellites. The data interpretation algorithms are targeted at detecting plant pests and diseases. Apollo Agriculture is a Kenyan company using AI to



interpret satellite data, soil data, farmer behavior, and crop yield models. The data interpretation algorithms allow the company to offer farmers customized financing as well as customized seed and fertilizer packages (Nanalyze 2019).

In view of the above examples and others not mentioned, there is clearly activity in AI R&D in Africa. It may be that the activity is minimal when compared with that of developed countries, but there is a very high level of interest in AI technologies by governments, academia, and the private sector, and activity levels will surely increase with time.

Having reviewed the general state of AI R&D in Africa, and having established that there is ongoing interest and activity in applying AI to a variety of fields, this chapter now turns to the specific application of AI to climate change.

---

## **Review of African AI Focusing on Climate Change Issues**

By 2050, it is widely expected that hundreds of millions of people in developing countries will have left their homes as a result of climate change – a mass displacement that will make already-precarious populations more vulnerable and impose heavy burdens on the communities that absorb them. Unfortunately, the world has barely begun to prepare for this impending crisis.

According to the World Politics Review, those displaced by climate change are neither true refugees nor traditional migrants, and thus occupy an ambiguous position under international law. Consequently, the world needs to agree on how to classify environmental migrants, as well as what their rights are. It also needs to strengthen its capacity to manage these mass migrations, without weakening existing international regimes for refugees and migrants (Patrick 2020).

Similarly, international organizations, such as the United Nations, as well as industry and social society are exploring technological solutions including the development of tools and technologies that leverage data sources from radio content, social media, mobile phones and satellite imagery, and technology toolkits. These toolkits can enhance decision-making by providing real-time situational awareness for project and policy implementation. The trend is moving towards a converging of exponential technologies (AI, robotics, drones, sensors, and networks). Although there is growing criticism of this trend toward ‘technologizing of care’, which can conflict with the centrality of the humanitarian principles, these technologies, in particular AI, have the potential to help Africa to be better prepared to thwart the effects of climate change, both through mitigation and adaptation.

In light of this, this section examines the use of AI that is being (or could be) used in Africa for any aspect of climate change such as weather prediction, agriculture, human migration, floods and droughts. These projects could be undertaken physically in Africa as well as in those countries that have Africa as their focus, and those that can be adapted to Africa. It assumes a broader definition of AI which includes the use of “software (and possibly also hardware) systems designed by humans that, given a complex goal, act in the physical or digital dimension by perceiving their environment through data acquisition, interpreting the collected” (European

Commission High-Level Expert Group on Artificial Intelligence 2018). It examines how a combination of technologies work together, including geospatial technologies, converging technologies such as robotic responders, swarm technology, and aerial drones which may also rely on geospatial data. Further, it also examines AI-driven platforms that crowdsource first-hand experiential data from those on the ground, and how these technologies could potentially transform disaster relief methods in Africa. Finally, it examines the issue of mobile connectivity and wireless networking trends and how improving these can give a newfound narrative power to those most in need. Although some of the projects examined in this section do not directly address climate change, per se, they may address other environmental concerns that are relevant to climate change.

## **Geospatial Technologies**

Africa has seen a steady increase in multi-stakeholder geospatial initiatives in recent years and these include those sponsored by the UN agencies, Public Private Partnerships, and initiatives led by international organizations and industry, especially global technology companies such as Google and Vodafone.

### **UN Agencies**

The UN, in particular its data science arm, the Global Pulse, has been working to support African governments to achieve the U.N. 2030 Agenda for Sustainable Development. The Global Pulse, working from its Kampala Lab in Uganda, has led the work to develop numerous toolkits that consolidate it as an important technical arm of the UN network (Pulse Lab Kampala 2018). These pieces of software are a key in informing the SDGs through big data, data science and artificial intelligence because they aggregate, anonymize, combine, analyze, and visualize data. During 2016 and 2017 the Lab has both created brand-new toolkits and adapted previously developed ones for new projects. This has been part of a bigger project under which, between 2016 and 2017, the Pulse Lab Kampala worked with various UN agencies and development partners in Uganda and the region to test, explore and develop 17 innovation projects. The Lab also furthered the development of tools and technologies that leverage data sources from radio content, social media, mobile phones and satellite imagery, and created technology toolkits. These toolkits can enhance decision-making by providing real-time situational awareness for project and policy implementation (Pulse Lab Kampala 2018).

The Pulse's projects sit in the current global policy shift which emphasizes technological tools as opposed to their application to improving knowledge about climate change. This is even reflected in the secondary school geography curriculum which has seen an introduction of GSI in some African countries (Cox et al. 2014). This shift is borne from the premise that geospatial technologies, synergetic applications of remote sensing, and geographical information systems, offer versatile cross-scale tools to study long term climate changes, and their impacts on social- and ecological systems.

According to the UN World Data Forum, the U.N. 2030 Agenda for Sustainable Development requires countries to be chiefly responsible for collecting information and monitoring progress towards achieving economic, social, and environmental sustainability (United Nations World Data Forum 2018). For instance, the UN World Data Forum has held sessions to enable the sharing of sound Earth Observation (EO) methods, tools, and technologies, as well as national use cases of effective integration of EO and geospatial data products with traditional and other relevant information sources in support of the Sustainable Development Goals (SDGs), targets, and indicators, and for informed decision-making. Some of the technologies discussed at such forms include the African Regional Data Cube, aimed to enable greater use of EO and geospatial data for sustainable development (Anderson et al. 2017).

To strengthen its work at policy level in this area, in 2019, the UN Pulse has been engaging African AI experts to lead efforts to draft a Code of Ethics for the use of AI-supported systems in humanitarian and development contexts (International Telecommunication Union 2019). Once developed, the Code may be used as guidance for the work at Global Pulse and at other UN organizations deploying AI for social good and to ensure the deployment of such technologies is both ethical and human rights respecting.

### **Public-Private Partnerships**

Similarly, the private sector has been working with governments on data science projects that leverage data for AI applications in humanitarian contexts. For instance, the Vodafone Foundation pioneered a program in Ghana to use aggregated anonymized data to help the government track and control epidemics to prevent widespread outbreaks (Vodafone 2018). The program, dubbed as one of the first of its kind globally, tracks and analyzes real-time trends in population movement. The program demonstrates the use of big data in situations directly relevant to climate change. The Ghana initiative is a good example of a multistakeholder approach to technology deployment for humanitarian ends as it is not only supported by Vodafone Ghana but also the Flowminder Foundation, an NGO that provides insights, tools and capacity-strengthening to governments as well as international agencies and NGOs (GhanaWeb 2019).

The South Africa company Aerobotics, mentioned above, operates a public private partnership that utilizes aerial imagery and machine learning algorithms to solve specific problems across some industries including insurance and agriculture. In May 2019, Aerobotics signed an agreement with Agri SA to offer free service for all South African farmers (Lukhanyu 2019). Drones are used to track tree health and size, using multispectral, high resolution imagery. The project also enables farmers to identify areas needing attention from historical satellite health data, and inspect these in the field using a mobile app. The Aerobotics project is supported by the South African Department of Environmental Affairs (DEA) which works with the Committee on Spatial Information (CSI) and the broader GIS community to define the data architecture, systems, standards, policies and processes for a fully integrated and effective spatial data infrastructure for the country. The Environmental Geographical Information Systems (E-GIS) webpage provides access to baseline

environmental geospatial data, map services, printable maps and relevant documents to users of geospatial technology, government, and the public (Department of Environmental Affairs South Africa 2016).

Another example, also out of South Africa, applies machine learning to the issue of air quality prediction (Chiwewe and Ditsela 2016). Stemming from the Green Horizons initiative, IBM researchers partnered with Chinese government researchers for the purpose of building air quality prediction software. In Johannesburg, the work is to adapt the air quality prediction software to the local context. The Green Horizon's system harnesses historical and real time data about weather, air quality, topography, and traffic reports to build predictions about air quality. The project's South Africa lead, Tapiwa Chiwewe, says that the task is to tweak the software to local particularities. For instance, Johannesburg does not have the dense network of air quality monitoring stations (eight stations compared to 35). Chiwewe and the team of researchers sought to 'teach' the software to work with more sparse data and to use intermediate fixes to make up for the lack of data.

## **The Private Sector, and Converging Exponential Technologies**

### **International Organizations & Global Technology Companies**

Globally, converging exponential technologies (AI, robotics, drones, sensors, networks) are transforming the future of disaster relief (Diamandis 2019). African stakeholders have been experimenting with these technologies in a variety of contexts. These efforts have been led by international organizations such as Omdena and Element AI, working with local African NGOs like R365 and the Nigerian NGO Renewable Africa (Adewumi 2020). Academic institutions and global technology companies such as Google also play a part in this work, which span the R&D process as well as prototyping and implementation. For example, the Canadian based Element AI has African-focused projects that support the use of robots for humanitarian purposes. Their intention is to develop human-machine collaborations that build up a trusted relationship with AI products and services already available. Two further examples are illustrative. Atlas AI, a Silicon Valley public benefit corporation, has teamed with the Alliance for a Green Revolution in Africa (AGRA), to apply predictive analytics and machine learning to help process numerous datasets in an effort to improve smallholding farming output (AGRA 2019). Pennsylvania State University developed, deployed, and continue to upgrade PlantVillage, a mobile application that uses an AI tool to diagnose crop diseases in Africa (Penn State 2019).

Global initiatives inspired by Kenya's Ushahidi are emerging that leverage AI, crowd sourced intelligence, and cutting-edge visualizations to optimize crisis response (Starbird 2012). Such projects include One Concern (2020), which employs AI in analytical disaster assessment and damage estimates. Crowdsourced intelligence (which includes predictive crisis mapping and AI-powered responses) is used in response to both natural disasters and humanitarian disasters. An open-source crisis-mapping software developed by Ushahidi is used for real-time mining

of social media, news articles, and geo-tagged, time-stamped data from countless sources (Meier 2012). As mobile connectivity and abundant sensors converge with AI-mined crowd intelligence, real-time awareness will only multiply in speed and scale (Diamandis 2019).

Other organizations are using similar crowdsourcing technologies to address different challenges, but such technologies are also helpful in understanding agricultural and other environment concerns. IBM's Hello Tractor is an open source mobile platform that enables farmers to access tractor services on demand (Assefa 2018). By using technology integrated from partners like the IoT companies Aeris and CalAmp, the platform can tell when a tractor is turned on and how far it travels. By using the platform, over the next 5 years, through a public-private partnership, John Deere plans to deploy 10,000 tractors in Nigeria, selling them to contractors who then rent them out to small farmers (Peters 2018). Considering that climate change is expected to increase uncertainty in the long-term viability of agricultural land, the availability of tractors for rent will be critical as a means for improving flexibility of farmers.

Another organization using AI-based crowdsourcing solutions to climate-related or climate-relevant challenges is Omdena, which sources ideas to respond to local challenges. Several of Omdena's projects are worth discussion. Under one of its challenges, 34 collaborators working together with the UN Refugee Agency (UNHCR) built several AI and machine learning solutions to predict forced displacement, violent conflicts, and climate change effects in Somalia (Omdena 2019). Their community of AI experts and data scientists have developed several solutions to predict climate change and forced displacement in Somalia, where millions of people are forced to leave their current area of residence due to natural and man-made disasters such as droughts, floods, and violent conflicts. This is a holistic project under which Omdena's challenge partner, UNHCR, provides assistance and protection for those who are forcibly displaced inside of Somalia. The findings will help UNHCR improve speed and efficiency of responses to such disruptions.

In a second project, Omdena's collaborators analyze conflict data to build a hot zone representation, which predicts the most dangerous locations and the highest fatalities (Omdena 2019). The machine learning model can help to optimize the allocation of utility personnel to handle incidents. A promising application of this technology is to leverage satellite images to assess the environmental impact of forced displacement and conflict by comparing the weekly Vegetation Health Index with human displacement data.

Omdena's projects are also focused on increasing the adoption of renewable energy, an important component of climate change mitigation. In Nigeria, Omdena's AI community built an interactive map showing the top Nigerian regions for solar power instalments (Adewumi 2020). The solutions will provide helpful insights for government and policy makers to make decisions on where to allocate resources in the most effective way. In a country where more than 100 million people lack stable access to electricity, renewable energy must be a major part of any environmentally friendly solution. The Omdena community generated a variety of outputs, including a grid coverage analysis and machine-learning-driven heatmaps to identify sites that

are most suitable for solar panel installation. Along with an interactive map listing the top Nigerian regions in terms of demand for electricity, such tools are helpful for those seeking to survey and validate locations before installing solar panels. This will enable data-driven investments and policy-making and potentially impact the lives of many people in Nigeria.

A particularly forward-looking initiative is the Microsoft AI for Earth grant program. One of the recipients of the grant is Upepo Technology, a Kenyan company that plans to use the grant in a water monitoring project. The company is deploying a large network of IoT devices, and employing AI algorithms to analyze the data from sensors monitoring reservoirs, boreholes, water kiosks, individual taps, and other water points. Considering the substantial impact that climate change has on issues pertaining to water – particularly by changing the patterns of precipitation – an enhanced ability to monitor water usage, wastage, and storage will greatly benefit the ability to deal with climate change impacts.

## University Activity

African universities and academic institutions are also setting up AI technology-based projects to tackle environmental issues, including Makerere University in Uganda and Carnegie Mellon University in Kigali, which was the first to offer a Master of Science Degree in Electrical and Computer Engineering with hands-on courses which include machine learning, robotics, and the internet of things (Carnegie Mellon University Africa). A few such projects are discussed below.

### AirQo

The Makerere University Artificial Intelligence Research Group (AIR Lab) specializes in the application of artificial intelligence and data science to challenges common in the developing world. AIR Lab received support from the Pulse Lab to set up AirQo – an air quality data monitoring, analysis and modelling platform in East Africa meant to achieve clean air for all African cities through leveraging data (Nabatte 2019). AirQo is deploying a growing network of low-cost air quality monitors. Using machine learning and artificial intelligence to collect and analyze data, the project makes air quality predictions useful in raising awareness and informing policy decisions. Future research plans include the development and deployment of machine learning methodology to analyze air pollution data from Kampala, in order to determine the source of the pollution and to aid the design of mitigating interventions.

### WIMEA-ICT

WIMEA-ICT is a combined research and capacity building project that seeks to improve weather information management in the entire East Africa region by development of ICT-based solutions (Norwegian Agency for Development Cooperation [NORAD] 2013). Funded by the Norwegian Agency for Development Cooperation (Norad) under the NORHED (Norwegian Programme for Capacity Development in Higher Education and Research for Development) scheme, the

project is a cooperation between Makerere University in Uganda, Dar es Salaam Institute of Technology (DIT) in Tanzania, the University of Juba in South Sudan, and the Geophysical Institute of the University of Bergen.

The project recognizes the wide-ranging importance of weather data and the problems that result when weather predictions are inaccurate. Although project documentation does not specify the use of AI, among the five components of the project at least one is ideal for incorporation of AI: development of numerical weather prediction models specifically designed for the East African context.

## The Potential of AI

It is not difficult to identify a long list of research projects that focus on various climate change issues in Africa. Many such projects include analyses of large datasets that would, seemingly, be ideal for analysis by AI algorithms. For example, Petja et al. (2004) describe an analysis of South African regional weather data dating from 1900 onward and satellite data dating from 1985 onward. The data are used to monitor regional climate and vegetation variations over time. In another example, Hagenlocher et al. (2014) describe the combination of numerous datasets to develop a cumulative climate change impact indicator. Applied to sub-Saharan Africa, the authors identified, evaluated, and mapped 19 hotspots that exhibited the most severe climate changes. In research out of Stanford University, Burke and Lobell (2017) demonstrated the importance of high-resolution satellite imagery data to estimate and understand yield variation among smallholder African farmers. This understanding generates various potential capabilities including the inexpensive measurement of the impact of specific interventions, the broader characterization of the source and magnitude of yield gaps, and the development of financial products aimed at African smallholders.

Although the immediately foregoing examples, and many other studies, do not specifically mention the use of AI, it is clear that large interrelated datasets are of vital importance to many different areas of research relevant to climate change. There is significant room for AI to be used by researchers to improve methodologies involving analysis of weather and other data (Rasp et al. 2018).

---

## Challenges and Future Applications

Development of advanced technologies typically encounters challenges, and AI technologies and applications with a focus on climate change are no exception. Besides the typical challenges of developing AI products and services, Africa presents unique challenges both technological and political/ethical.

## Scope of the Problem

Technologies powered by machine learning (ML) algorithms, including those discussed herein that aid climate analysis (Huntingford et al. 2019), have advanced

dramatically, triggering breakthroughs in other research sectors. Although a considerable number of isolated Earth System features have been analyzed with ML techniques, more generic application to understand better the full climate system has not occurred, and the technology to do so may be quite far from the current state of development. At this stage of development, Artificial intelligence (AI) can be used to analyze smaller systems and provide enhanced warnings of approaching weather features, including extreme events. ML and AI can aid in understanding and improving existing data and simulations, as it has done in other systems (Huntingford et al. 2019). For instance, Airbus Defence and Space is using TensorFlow, the open-source set of AI tools from Google, to extract information from satellite images and offer valuable insights to customers. In a similar manner, AI can be used to detect and analyze isolated Earth System features and climate patterns, especially with the latest release of TensorFlow Quantum which enables a faster prototyping of ML models. Nevertheless, modeling the entire global climate remains challenging, and predictions from such models vary at all scales. Until the computational power and models have been refined to enable accurate global predictions, the need remains for smaller scale models. Local modeling requires context specific data and algorithms, so efforts toward development of Africa-specific climate change models must continue to be encouraged.

## Ethical Issues of Predicting Climate Change Impacts

AI algorithms are well suited to analyze large datasets and detect patterns, so they are naturally well suited for looking at patterns of large-scale human movement and the data that might be associated with such movement (Beduschi 2020). For example, it is postulated that economic data such as GDP growth, along with trends in other data such as population growth and weather data (which might indicate food security issues), can be used to predict future large-scale human migration (Nyoni 2017). Accuracy of the predictions can be increased by incorporating real-time data points, such as announcements by government central banks, military actions, and weather observations.

Assuming there is a reasonable level of accuracy, predicting the location or the country most likely to suffer the next crisis of human migration has both remedial and prophylactic uses (TEDx Talks 2016). Humanitarian organizations can begin preparations for dealing with the crisis, and intergovernmental financial institutions can consider policy measures to ease debt burdens or encourage growth. Local and national governments of the yet-to-be affected regions can take measures to calm tensions and address the issues that cause migration. As useful as such predictions may be, this use case raises extreme ethical issues, for example by encouraging international efforts (including both active and passive efforts) to promote regime change where a specific government's policies appear to be leading to a future migratory crisis. Additionally, a prediction of a future migratory crisis may be a self-fulfilling prophecy, by increasing tension among the population and reducing investor confidence in the economy. The good intentions of those developing the



technology, in this case, may increase the likelihood of the humanitarian disasters that they are seeking to ease.

## Data Inadequacies

Apart from ethical issues, the development of AI for combating climate change in Africa may be severely hampered by a lack of data. The concept of a digital divide is many decades old, and documentation of the digital divide separating Africa from other regions is well established (Karar 2019). The modern-day extension of this concept is that of a data divide (Castro 2014), also referred to as a data desert or data poverty. First recognized with respect to certain populations in developed countries, the data divide is a problem in Africa and with respect to climate change for a variety of reasons. Historical weather data is less extensive in Africa compared with other parts of the world (Dinku 2018). Current data is also less extensive, as there are fewer weather satellites monitoring Africa than other regions and ground-based sensing is also less extensive (Dinku et al. 2011).

Even where there is historical climate data, those data may be inaccessible – for example, because African governments and their weather agencies are increasingly seeking to commercialize the data, or because the data are not digitized (Nordling 2019). In this context, the issue of a data divide is complex and is indicative of an uneven power dynamic. As with many other areas, Africa engages the rest of the world from a disadvantaged position, and the unbalanced power of the relationship may negatively affect the outcome. Whereas monetizing data is a common practice in developed countries, because African nations need significant help in building the infrastructure for collecting data, they are expected to willingly release the data. A data commons, in which climate data is readily available for all to use, is vitally important to help climate scientists and other interested parties understand the impacts of climate change in Africa. Nevertheless, the desire of data holders to seek ways of monetizing their data is understandable.

The concept of Africa as a data desert may, therefore, be unfairly characterizing the true situation. Rather than an absence of data, as the desert analogy implies, it is probably more accurate to say that data are present but not as readily available or easily searchable. As mentioned previously, African government websites may lack updated data (Ndongmo 2016), but this does not mean that they are not collecting the data. Open data portals are present in a few countries but have not become mainstream methods for governments to disseminate datasets. In some cases, governments generate revenue by selling datasets, and therefore have little incentive to making them available on an open platform. Efforts at increasing the volume of data collected about Africa should take into account these issues.

Regardless of the causes of the data divide, there is no doubt that insufficient data is important in Africa's ability to adapt to climate change. Climate change does not affect all geographical locations equally (United States Environmental Protection Agency (USEPA) 2017). As the global average temperature rises, and sea levels rise, average temperatures in some areas may decline. Overall rainfall may increase or

decrease in any particular location, depending on a variety of factors. Extremes in precipitation and temperatures will also be in homogeneously affected. These variations would be less problematic if data were gathered with uniform consistency in all locations, but as mentioned previously, data collection in Africa is less consistent and less thorough. The result of this situation is likely to be less accurate predictions of the effects of climate change in Africa compared with other regions. Less accurate predictions may mean that local and international decision makers are unable to adequately prepare for the impacts of climate change.

Whether due to inefficient dissemination or to a fundamental lack of collection, or to some other reasons, the lack of available data has severe implications for the use of AI in adapting to climate change. Without sufficient data, AI algorithms are substantially less accurate and useful (West and Allen 2018). The trend in Africa, however, appears to be shifting toward a wider availability of data and a greater effort toward utilizing all available tools, including AI, in addressing climate change issues.

---

## Conclusions

Some countries are serious in their look toward the future. For example, Ethiopia launched its first observatory satellite into space in 2019. The 70-kg remote sensing satellite is to be used for agricultural, climate, mining and environmental observations, allowing the Horn of Africa to collect data and improve its ability to plan for changing weather patterns for example. The satellite will operate from space around 700 km above the surface of earth. Developments in Ethiopia follow the introduction by the African Union of an African space policy, which calls for the development of a continental outer-space program and the adoption of a framework to use satellite communication for economic progress. Clearly, efforts such as this are forward thinking and will help the continent to address the lack of data that hampers the use of AI to address issues of climate change.

The problems of climate change are global, but Africa is likely to suffer to a greater degree compared with other regions. Scientists and policymakers in Africa need every available tool to help the continent adapt to the changes, but should always keep in mind the severity and scale of the problem. Notwithstanding the benefits that AI clearly brings, or promises to bring, in the efforts to adapt to climate change, it is clear that the fourth industrial revolution cannot fix what the second industrial revolution started.

---

## References

- Adeoye A (2019) Google has opened its first Africa Artificial Intelligence lab in Ghana. <https://edition.cnn.com/2019/04/14/africa/google-ai-center-accra-intl/index.html>. Accessed 16 Mar 2020
- Adewumi AE (2020) AI for the people: how to stop the Nigerian energy crisis. <https://omdena.com/blog/ai-energy-crisis>. Accessed on 15 Mar 2020
- African Soil Information Service, AFSIS. <http://africasoils.net/>. Accessed on 15 Mar 2020

- Alliance for a Green Revolution in Africa (AGRA) (2014) Africa agriculture status report 2014: climate change and smallholder agriculture in sub-saharan Africa, AGRA Report. Nairobi. <https://hdl.handle.net/10568/42343>. Accessed on 16 Mar 2020
- Alliance for a Green Revolution in Africa (AGRA) (2019) New partnership to boost food security in Africa by use of artificial intelligence. <http://agra.org/new-partnership-to-boost-food-security-in-africa-by-use-of-artificial-intelligence>. Accessed on 14 Mar 2020
- Anderson K, Ryan B, Sonntag W, Kavvada A, Friedl L (2017) Earth observation in service of the 2030 agenda for sustainable development. *Geo Spat Inf Sci* 20(2):77–96. <https://doi.org/10.1080/10095020.2017.1333230>
- Assefa S (2018) IBM Research, Hello Tractor pilot agriculture digital wallet based on AI and blockchain. <https://www.ibm.com/blogs/research/2018/12/hello-tractor/>. Accessed on 16 Mar 2020
- Aydoğdu M, Boyraz N (2012) Stem rust (ug99), seen as a threat globally. *Akden iz Univ Ziraat Fak Derg* 25(1):23–28. [https://www.researchgate.net/publication/305687716\\_Stem\\_rust\\_ug99\\_seen\\_as\\_a\\_threat\\_globally](https://www.researchgate.net/publication/305687716_Stem_rust_ug99_seen_as_a_threat_globally). Accessed on 16 Mar 2020
- Beduschi A (2020) International migration management in the age of artificial intelligence. *Migr Stud*. <https://doi.org/10.1093/migration/mnaa003>
- Burke M, Lobell DB (2017) Satellite-based assessment of yield variation and its determinants in smallholder African systems. *Proc Natl Acad Sci U S A* 114(9):2189–2194. <https://doi.org/10.1073/pnas.1616919114>
- Campbell M, Tishkoff S (2008) African genetic diversity: implications for human demographic history, modern human origins, and complex disease mapping. *Annu Rev Genomics Hum Genet* 9:403–433. <https://doi.org/10.1146/annurev.genom.9.081307.164258>
- Carnegie Mellon University Africa. <https://www.africa.engineering.cmu.edu/>. Accessed on 17 Mar 2020
- Castro D (2014) The rise of data poverty in America. Report from Center for Data Innovation. Available at: <http://www2.datainnovation.org/2014-data-poverty.pdf>. Accessed on 13 Mar 2020
- Chiwewe T, Ditsela J (2016) Machine learning based estimation of ozone using spatio-temporal data from air quality monitoring stations. Paper presented at the 14th International Conference on Industrial Informatics, Poitiers, France, 18–21 July 2016. <https://doi.org/10.1109/INDIN.2016.7819134>
- Cox H, Kelly K, Yetter L (2014) Using remote sensing and geospatial technology for climate change education. *J Geosci Educ* 62(4):609–620. <https://doi.org/10.5408/13-040.1>
- Deep Learning Indaba. <http://www.deeplearningindaba.com>. Accessed on 16 Mar 2020
- Department of Environmental Affairs South Africa (2016) Welcome to environmental GIS. <https://egis.environment.gov.za/>. Accessed on 16 Mar 2020
- Diallo AB, Nguifo EM, Dhifli W, Azizi E, Prabhakaran S, Tansey W (2019) Selected papers from the workshop on computational biology: joint with the international joint conference on artificial intelligence and the international conference on machine learning 2018. *J Comput Biol* 26:6. <https://doi.org/10.1089/cmb.2019.29020.abd>
- Diamandis P (2019) AI and robotics are transforming disaster relief. <https://singularityhub.com/2019/04/12/ai-and-robotics-are-transforming-disaster-relief/>. Accessed on 17 Mar 2020
- Dinku T (2018) Overcoming challenges in the availability and use of climate data in Africa. ICT Update. <https://ictupdate.cta.int/en/article/overcoming-challenges-in-the-availability-and-use-of-climate-data-in-africa-sid06fd8a811-e179-4fa5-9c8f-806bd2f27c3e>. Accessed on 13 Mar 2020
- Dinku T, Asefa K, Hilermariam K, Grimes D, Connor S (2011) Improving availability, access and use of climate information. *World Meteor Org Bull* 60(2) Available at: <https://public.wmo.int/en/bulletin/improving-availability-access-and-use-climate-information>. Accessed on 16 Mar 2020
- European Commission High-Level Expert Group on Artificial Intelligence (2018) The ethics guidelines for trustworthy artificial intelligence. <https://ec.europa.eu/digital-single-market/en/high-level-expert-group-artificial-intelligence>. Accessed on 16 Mar 2020
- GhanaWeb (2019) GSS partners Vodafone & Flowminder to produce reliable data for sustainable development. <https://www.ghanaweb.com/GhanaHomePage/NewsArchive/GSS-partners->

- Vodafone-amp-Flowminder-to-produce-reliable-data-for-sustainable-development-814189. Accessed on 17 Mar 2020
- Hagenlocher M, Lang S, Hölbling D, Tiede D, Kienberger S (2014) Modeling hotspots of climate change in the Sahel using object-based regionalization of multidimensional gridded datasets. *IEEE J Sel Top Earth Obs Remote Sens* 7(1):229–234. <https://doi.org/10.1109/JSTARS.2013.2259579>
- Huntingford C, Jeffers E, Bonsall M, Christensen H, Lees T, Yang H (2019) Machine learning and artificial intelligence to aid climate change research and preparedness. *Environ Res Lett* 14(12):124007. <https://doi.org/10.1088/1748-9326/ab4e55>
- International Telecommunication Union (2019) United Nations activities on artificial intelligence. Compendium presented and discussed at the AI for Good UN Partners Meeting, UNWomen Headquarters in New York, 23 September 2019. [https://www.itu.int/dms\\_pub/itu-s/opb/gen/S-GEN-UNACT-2019-1-PDF-E.pdf](https://www.itu.int/dms_pub/itu-s/opb/gen/S-GEN-UNACT-2019-1-PDF-E.pdf). Accessed on 16 Mar 2020
- Johnson K (2018) Major AI conference is moving to Africa in 2020 due to visa issues. <https://venturebeat.com/2018/11/19/major-ai-conference-is-moving-to-africa-in-2020-due-to-visa-issues/>. Accessed on 16 Mar 2020
- Johnson K, Pasquale F, Chapman J (2019) Artificial intelligence, machine learning, and bias in finance: toward responsible innovation. *Fordham Law Rev* 88(2):499. <https://ir.lawnet.fordham.edu/flr/vol88/iss2/5>. Accessed on 12 Mar 2020
- Karar H (2019) Algorithmic capitalism and the digital divide. *J Dev Soc* 35(4):514–537
- Knight W (2019) African AI experts get excluded from a conference – again. <https://www.wired.com/story/african-ai-experts-get-excluded-from-a-conference-again/>. Accessed on 16 Mar 2020
- Lecoq M (2003) Desert locust threat to agricultural development and food security and FAO/International role in its control. *Arab J Pl Prot* 21:188–193. [https://www.researchgate.net/publication/242118174\\_Desert\\_Locust\\_Threat\\_to\\_Agricultural\\_Development\\_and\\_Food\\_Security\\_and\\_FAOInternational\\_Role\\_in\\_its\\_Control](https://www.researchgate.net/publication/242118174_Desert_Locust_Threat_to_Agricultural_Development_and_Food_Security_and_FAOInternational_Role_in_its_Control). Accessed on 17 Mar 2020
- Lukhanyu M (2019) Agri SA & Aerobotics partner to offer free service for all South African farmers. <https://techmoran.com/2019/05/15/agri-sa-aerobotics-partner-to-offer-free-service-for-all-south-african-farmers/>. Accessed on 16 Mar 2020
- Meier P (2012) Crisis mapping in action: how open source software and global volunteer networks are changing the world one map at a time. *J Map Geogr Libr* 8(2):89–100. <https://doi.org/10.1080/15420353.2012.663739>. Accessed on 15 Mar 2020
- Microsoft Access Partnership University of Pretoria (2018) Artificial intelligence for Africa: An opportunity for growth, development and democratisation. White Paper. [https://www.up.ac.za/media/shared/7/ZP\\_Files/ai-for-africa.zp165664.pdf](https://www.up.ac.za/media/shared/7/ZP_Files/ai-for-africa.zp165664.pdf). Accessed on 14 Mar 2020
- Nabatte P (2019) Mak's AirQo project is a US 1.3million Google AI impact grantee. <https://news.mak.ac.ug/2019/05/maks-airqo-project-us13m-google-ai-impact-grantee>. Accessed on 14 Mar 2020. See further AirQo <https://www.airqo.net/>. Accessed on 17 Mar 2020
- Nanalyze (2019) Top-10 artificial intelligence startups in Africa. <https://www.nanalyze.com/2019/04/artificial-intelligence-africa/>. Accessed on 16 Mar 2020
- Ndongmo K (2016) African government websites – new and improved, or not? Report on medium. Edition of January 8 2016. Available at: <https://medium.com/@kathleenndongmo/african-government-websites-new-and-improved-or-not-746a5a5a62d>. Accessed on 16 Mar 2020
- Nordling L (2019) Scientists struggle to access Africa's historical climate data. *Nature* 574:605–606
- Norwegian Agency for Development Cooperation (NORAD) (2013) Improving weather information management in East Africa. <https://norad.no/en/front/about-norad/>. Accessed 10 Mar 2020
- Nyoni B (2017) How Artificial Intelligence can be Used to Predict Africa's Next Migration Crisis. <https://www.unhcr.org/innovation/how-artificial-intelligence-can-be-used-to-predict-africas-next-migration-crisis/>. Accessed on 13 Mar 2020
- Nzouankeu A (2019) App helps African farmers detect crop disease. <https://www.voanews.com/africa/app-helps-african-farmers-detect-crop-disease>. Accessed on 17 Mar 2020
- Omdena (2019) Using AI to predict climate change and forced displacement. <https://omdena.com/challenges/ai-climate-change>. Accessed on 10 Mar 2020

- One Concern (2020) What we do: We are advancing science based technology to make disasters less disastrous. <https://www.oneconcern.com/product>. Accessed on 16 Mar 2020
- Oxford Insights International Development Research Centre (2019) Government artificial Intelligence readiness index 2019. <https://www.oxfordinsights.com/ai-readiness2019>. Accessed on 12 Mar 2020
- Patrick S (2020) How should the world respond to the coming wave of climate migrants? World Politics Review. <https://www.worldpoliticsreview.com/articles/28603/how-should-the-world-respond-to-the-coming-wave-of-climate-migrants>. Accessed on 15 Mar 2020
- Peacock C, Mungai F (2019) Impact investment favours expats over African entrepreneurs: Here's how to fix that. World Economic Forum. <https://www.weforum.org/agenda/2019/07/impact-investors-favour-expats-over-african-entrepreneurs-here-s-how-to-fix-that/>. Accessed on 12 Mar 2020
- Penn State. (2019). New AI app predicts climate change stress for farmers in Africa: researchers will unveil their app for climate-smart agriculture to coincide with the UN Climate Action Summit. <http://www.sciencedaily.com/releases/2019/09/190923082252.htm>. Accessed 12 Mar 2020
- Perrault R, Shoham Y et al (2019) The AI index 2019 annual report. AI Index Steering Committee Human-Centered AI Institute, Stanford University, Stanford. Accessed on 13 March 2020. Available at: [https://hai.stanford.edu/sites/xg/files/sbybj10986/f/ai\\_index\\_2019\\_report.pdf](https://hai.stanford.edu/sites/xg/files/sbybj10986/f/ai_index_2019_report.pdf)
- Peters A (2018) This startup lets african farmers hire and on-demand tractor to boost their harvests. <https://www.fastcompany.com/90227534/hello-tractor-and-john-deere-bring-10000-tractors-to-africa>. Accessed on 20 Sept 2019
- Petja BM, Malherbe J, van Zyl D (2004) Using satellite imagery and rainfall data to track climate variability in South Africa. Paper presented at the 2004 IGARSS 2004 IEEE International Geoscience and Remote Sensing Symposium, Anchorage, Alaska, 20–24 September 2004. <https://doi.org/10.1109/IGARSS.2004.1369098>
- Pulse Lab Kampala (2018) Pulse Lab Kampala progress report 2016–2017. <https://beta.unglobalpulse.org/document/pulse-lab-kampala-progress-report-2016-2017-2/>. Accessed on 16 Mar 2020
- Rasp S, Pritchard MS, Gentine P (2018) Deep learning to represent subgrid processes in climate models. Proc Natl Acad Sci U S A 115(39):9684–9689. <https://doi.org/10.1073/pnas.1810286115>
- Scoones I, Thompson J (2011) The politics of seed in Africa's green revolution: alternative narratives and competing pathways. IDS Bull 42(4):1–23
- Starbird K (2012) Crowdwork, crisis and convergence: how the connected crowd organizes information during mass disruption events. Dissertation, University of Colorado. [http://faculty.washington.edu/kstarbi/starbird\\_dissertation\\_final.pdf](http://faculty.washington.edu/kstarbi/starbird_dissertation_final.pdf). Accessed on 14 Mar 2020
- TEDx Talks (2016) Predicting Africa's Next Refugee Crisis Using AI|Babusi Nyoni|TEDxCapeTown In: Youtube. <https://www.youtube.com/watch?v=lsi8ZgTvbT4>. Accessed on 14 Mar 2020
- The Economist (2020) China's success on AI has relied on good data. <https://www.economist.com/technology-quarterly/2020/01/02/chinas-success-at-ai-has-relied-on-good-data>. Accessed on 10 Mar 2020
- The Guardian (2017) 'Tsunami of data' could consume one fifth of global electricity by 2025. <https://www.theguardian.com/environment/2017/dec/11/tsunami-of-data-could-consume-fifth-global-electricity-by-2025>. Accessed on 10 Mar 2020
- The World Bank (2014) Land and food security. <https://www.worldbank.org/en/topic/agriculture/brief/land-and-food-security1>. Accessed on 17 Mar 2020
- TOP500.org (2019) TOP500 lists. <https://www.top500.org/lists/top500/>. Accessed on 6 Mar 2020
- Tortoise Intelligence (2019) The global AI index. <https://www.tortoisemedia.com/intelligence/ai/>. Accessed on 12 Mar 2020
- United Nations World Data Forum (2018) (TA2.16) Earth observation applications for the sustainable development goals: opportunities for scaling successful methods. <https://unstats.un.org/>

- [undataforum/sessions/ta2-16-earth-observation-applications-for-the-sustainable-development-goals-opportunities-for-scaling-successful-methods/](https://undataforum.org/sessions/ta2-16-earth-observation-applications-for-the-sustainable-development-goals-opportunities-for-scaling-successful-methods/). Accessed on 16 Mar 2020
- United States Environmental Protection Agency (2017) International Climate Change Impacts. Report from Climate Change Impacts edition of January 19 2017. Available at: [https://19january2017snapshot.epa.gov/climate-impacts/international-climate-impacts\\_.html](https://19january2017snapshot.epa.gov/climate-impacts/international-climate-impacts_.html). Accessed on 16 Mar 2020
- Vodafone (2018) Vodafone Foundation to use aggregated anonymised mobile data to help prevent spread of epidemics in transformative ‘Big data for good’ programme. <https://www.vodafone.com/news-and-media/vodafone-group-releases/news/vodafone-foundation-use-aggregate-data>. Accessed on 15 Mar 2020
- Weldemariam K, Pickover C, Kozloski J, Gordon M (2020) Artificial Intelligence for providing enhanced microblog message insertion, US Patent Application 20200028885, 23 Jan 2020
- West D, Allen J (2018) How Artificial Intelligence is transforming the world. The Brookings Institution report. Available at: <https://www.brookings.edu/research/how-artificial-intelligence-is-transforming-the-world/>. Accessed on 04 Nov 2020

**Open Access** This chapter is licensed under the terms of the Creative Commons Attribution 4.0 International License (<http://creativecommons.org/licenses/by/4.0/>), which permits use, sharing, adaptation, distribution and reproduction in any medium or format, as long as you give appropriate credit to the original author(s) and the source, provide a link to the Creative Commons license and indicate if changes were made.

The images or other third party material in this chapter are included in the chapter's Creative Commons license, unless indicated otherwise in a credit line to the material. If material is not included in the chapter's Creative Commons license and your intended use is not permitted by statutory regulation or exceeds the permitted use, you will need to obtain permission directly from the copyright holder.





# Impact of Moisture Flux and Vertical Wind Shear on Forecasting Extreme Rainfall Events in Nigeria

# 56

Olumide A. Olaniyan, Vincent O. Ajayi, Kamoru A. Lawal, and Ugbah Paul Akeh

## Contents

Introduction .....	1128
Description of the Study Area and Methodology .....	1130
Study Area .....	1130
Data .....	1131
Research Methodology .....	1132
Result .....	1134
Convective Days .....	1134
Non-convective Day .....	1145
Mean HMF <sub>D</sub> and CAPE at the Surface, Three Days Prior and Three Days After Storm Events .....	1149
Conclusion .....	1152
References .....	1156

This chapter was previously published non-open access with exclusive rights reserved by the Publisher. It has been changed retrospectively to open access under a CC BY 4.0 license and the copyright holder is “The Author(s)”. For further details, please see the license information at the end of the chapter.

O. A. Olaniyan (✉) · U. P. Akeh  
National Weather Forecasting and Climate Research Centre, Nigerian Meteorological Agency,  
Abuja, Nigeria

V. O. Ajayi  
West African Science Service Center on Climate Change and Adapted Land Use, Federal  
University of Technology, Akure, Ondo State, Nigeria

Department of Meteorology and Climate Science, Federal University of Technology, Akure, Nigeria  
e-mail: [voajayi@futa.edu.ng](mailto:voajayi@futa.edu.ng)

K. A. Lawal  
National Weather Forecasting and Climate Research Centre, Nigerian Meteorological Agency,  
Abuja, Nigeria

African Climate and Development Initiative, University of Cape Town, Cape Town, South Africa

---

**Abstract**

This chapter investigates extreme rainfall events that caused flood during summer months of June–September 2010–2014. The aim is to determine the impact of horizontal moisture flux divergence (HMFD) and vertical wind shear on forecasting extreme rainfall events over Nigeria. Wind divergence and convective available potential energy (CAPE) were also examined to ascertain their threshold values during the events. The data used include rainfall observation from 40 synoptic stations across Nigeria, reanalyzed datasets from ECMWF at  $0.125^\circ \times 0.125^\circ$  resolution and the Tropical Rainfall Measuring Mission (TRMM) dataset at resolution of  $0.25^\circ \times 0.25^\circ$ . The ECMWF datasets for the selected days were employed to derive the moisture flux divergence, wind shear, and wind convergence. The derived meteorological parameters and the CAPE were spatially analyzed and superimposed on the precipitation obtained from the satellite data. The mean moisture flux and CAPE for some northern Nigerian stations were also plotted for 3 days prior to and 3 days after the storm. The result showed that HMFD and CAPE increased few days before the storm and peak on the day of the storms, and then declined afterwards. HMFD values above  $1.0 \times 10^{-6} \text{ g kg}^{-1} \text{ s}^{-1}$  is capable of producing substantial amount of rainfall mostly above 50 mm while wind shear has a much weaker impact on higher rainfall amount than moisture availability. CAPE above  $1000 \text{ J kg}^{-1}$  and  $1500 \text{ J kg}^{-1}$  are favorable for convection over the southern and northern Nigeria, respectively. The study recommends quantitative analysis of moisture flux as a valuable short-term severe storm predictor and should be considered in the prediction of extreme rainfall.

---

**Keywords**

Mesoscale convective system · Moisture flux divergence · Wind shear · Extreme rainfall · Flood

---

**Introduction**

Human-induced climate change has increased the amount of water vapor in the atmosphere and has caused adverse effects on different regions, ecosystems, and economies across the world (Nwankwoala 2015). These effects depend not only on the sensitivity of populace to climate change but also on their ability to adapt to risks and changes associated with it. Since the atmospheric moisture budget plays an important role in the hydrology of a particular region, the changing weather patterns caused by climate change has increased the incidences of extreme rainfall events (Roshani et al. 2012; Weisman et al. 1988). Rainfall variability associated with climate change has impacted socioeconomic activities such as agriculture, food security, water resources management, health sector, hydroelectric power generation, and dam management among others in Nigeria (Bello 2010). Most of the negative effects of rainfall variability are on agriculture since majority of farmers



in the country depend on rain-fed agriculture for livelihood (IPCC 2014; Lawal et al. 2016). Levels of adaptation of farmers in Nigeria to climate change is low, due to lack of adequate education, assets, information, and income (Madu 2016), and consequently agriculture is more vulnerable to climate change impact. Rainfall over Nigeria is mostly from the West African Monsoon systems (WAMS) (Diatta and Fink 2014), and agriculture is an important sector of economy of the country which is highly dependent on the WAMS (Raj et al. 2019). Studies have shown that the complexity of the atmospheric dynamics that generate rainfall, temporal and spatial variation of its scale made it difficult to understand and model. Also, the required parameters to predict it are usually complex even for a short-term period (Sumi et al. 2012). Majority of the results of studies conducted on extreme precipitation events over Nigeria showed that there have been some notable increase in intensity of rainfall extremes which usually claim many lives and properties (Okorie 2015).

In recent times, incidences of large storms have become more frequent with increased intensity, especially the occurrences of high rainfall in form of intense single-day events causing devastating flood (Enete 2014). However, short-range forecasting of these flood occurrences has been a great challenge. Studies have also shown that the distinctive property of West African monsoon flow is that there is seasonal, monthly, and daily variability in its moisture content mainly in the lowest 1 km of the atmosphere (Omosho and Abiodun 2007). Furthermore, the intensity and duration of extreme rainfall are majorly dependent on the adequacy of moisture carried by the moist southwesterly flow from the South Atlantic Ocean. Studies have also shown that the daily variability of moisture advection mechanisms is responsible for the changes in the intensity and amount of rainfall (Omosho et al. 2000). Couvreur et al. (2010) noted that at low level, daily moisture transport takes place with periodic northward advection of moisture flux that has 3–5 days frequency. A study conducted by Bechtold et al. (2004) also showed that large-scale thunderstorms in form of Mesoscale Convective Systems (MCSs) are formed over West Africa when there is constant supply of low-level moisture. The action of synoptic scale intensification of the St. Helena high pressure system over the South Atlantic Ocean is majorly responsible for moisture divergence into West Africa. Similarly, in a numerical study of moisture build-up and rainfall done by Omosho and Abiodun (2007), it was reported that the rainfall amount does not depend on the monsoon flow alone but majorly on the sufficiency and the variability of its moisture content. Other studies have also examined the influence and interaction of different scales of motion such as African Easterly Jet (AEJ), Tropical Easterly Jet (TEJ), and African Easterly Waves (AEW) on the formation of MCSs (Nicholson 2013). These studies focused mainly on the scale interactions responsible for seasonal variability in weather pattern during northern summer (Janicot et al. 2011). They, however, did not consider in detail the quantity of daily moisture advection responsible for these rainfall extremes. The main focus of this chapter is to contribute to the understanding of the impact of moisture flux on the rainfall amount. Hence, it is necessary to study extreme precipitation events and diagnose the signatures of the meteorological parameters peculiar to such events. Studying this may enhance the assessment of the manner in which extreme rainfall events evolve and therefore provide a short-term early warning

method to forecasters. It will also assist in understanding the evolution of some derived meteorological parameters such as the moisture flux which determines the quantity of rainfall and the wind shear which determines the life span of the storm (Weisman et al. 1988). Thorough understanding of these parameters will aid reliable short-term flood forecast. The usefulness of horizontal moisture flux at or near the earth's surface as a thunderstorm predictor has been recognized throughout various studies (Beckman 1990). Apart from the availability of moisture, sustenance of MCSs also requires a certain magnitude of vertical wind shear to produce a stronger and longer-lived system (Weisman and Rotunno 2004). Observational and numerical studies have revealed that horizontal winds and their vertical structures have important impacts on convective development; to buttress this point, Omotosho (1987) noted that thunderstorms occur, most frequently, in association with low-level wind shears below the AEJ (surface to 700 hPa) ranging from  $-20$  to  $-5 \text{ s}^{-1}$  and for mid troposphere (700–400 hPa) in the range of 0 to  $10 \text{ s}^{-1}$ . Despite the importance of wind shear, its effect on MCS has not been treated explicitly over Nigeria.

Most climate prediction models do not perform well in prediction of extreme rainfall events over West Africa because of their low resolution (Nyakwada 2004), the nature of parameterization schemes employed in the model, scarcity of real-time data, and mostly due to the convective nature of West African rainfall, hence the forecast of extreme rainfall event is a major challenge to forecasters in West Africa. The aim of this chapter is therefore to determine the impact of moisture flux, vertical wind shear, and other derived meteorological parameters such as wind divergence and convective available potential energy (CAPE) on MCSs during extreme rainfall events over Nigeria. Therefore, the study investigates the spatiotemporal variability of moisture flux that feeds into MCSs and its impacts on the occurrences of high impact rainfall. The objective is to assess the threshold values of derived meteorological parameters responsible for isolated cases of extreme precipitation in order to enhance its predictability and contribute to the understanding of the impact of moisture flux on the amount of precipitation. This research makes use of a synergistic approach involving the moisture flux divergence, wind shear analysis below and above the AEJ, and CAPE. The spatial distribution of these derived parameters is considered, with a focus on understanding their contribution to the formation and sustenance of MCSs during extreme rainfall events. This chapter will be a useful guide for further investigations into accurate prediction of high impact rainfall that can result into flood events using moisture flux analysis.

---

## Description of the Study Area and Methodology

### Study Area

Nigeria is situated between latitudes  $4^\circ$  and  $14^\circ\text{N}$  and longitudes  $2^\circ$  and  $15^\circ\text{E}$  and falls within the tropics. It shares borders with Niger in the north, Chad in the northeast, Benin in the west, Cameroon in the east, and its coast in the south borders the Gulf of Guinea on the South Atlantic Ocean. Precipitation is received mainly



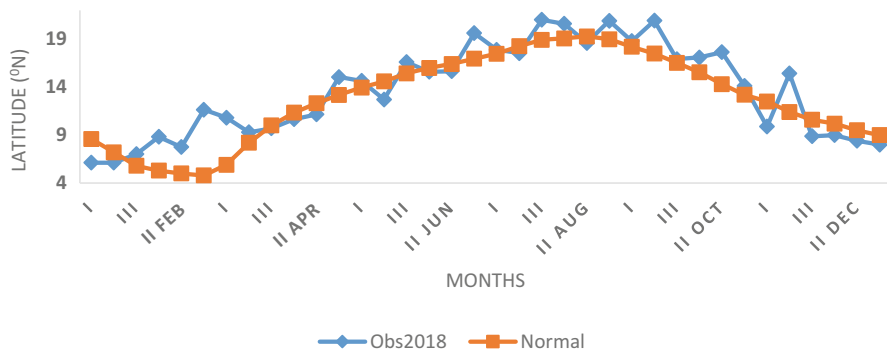
**Fig. 1** Map of Nigeria showing the whole country as study area and spatial distribution of Nigerian Meteorological Agency synoptic stations used in this chapter

during the northern hemispheric summer, which is referred to as the wet seasons. Moist southwesterly winds from the South Atlantic Ocean prevail during the summer while dry northeasterlies from the Sahara desert are dominant in the winter which is the dry season (Fig. 1).

The confluence zone between both wind systems is the Inter-tropical Discontinuity (ITD). The surface location of the ITD significantly accounts for rainfall interannual variability in the country (Nicholson 2009). The ITD fluctuates seasonally during the northern summer over West Africa and migrates northward from its winter position of 4°N to its northernmost position of about 22°N (Fig. 2). The amount of rainfall experienced by different areas depends on the position of the ITD. Most of the convective rainfall follows the south-north-south displacement of the ITD (Sultan and Janicot 2003).

## Data

Daily data for selected days of heavy rainfall was obtained from the European Centre for Medium-Range Weather Forecast's (ECMWF) ERA-INTERIM dataset on a gridded point of  $0.125^\circ \times 0.125^\circ$  and pressure levels of 1000, 850, 700, 400, and 200 hPa for the summer months of June–September 2010–2014. The daily datasets



**Fig. 2** Decadal latitudinal positions of the ITD in 2018 and its climatological mean over Nigeria. (Source: NiMet Climate Review Bulletin 2018)

are convective available potential energy (CAPE), specific humidity, zonal (U), meridional (V) winds, and divergence. Daily-accumulated rainfall was obtained from Tropical Rainfall Measuring Mission (TRMM) dataset, at a resolution of  $0.25^\circ \times 0.25^\circ$ . Observed rainfall for the months of June–September 2010–2014 was obtained from the Nigerian Meteorological Agency (NiMet) from 40 synoptic stations over Nigeria as shown in Fig. 1 to validate the TRMM dataset. Days of unusually high amount of rainfall during the months of June–September were selected from 2010 to 2014.

## Research Methodology

Derived meteorological parameters such as moisture flux, CAPE, vertical wind shear, monsoon depth, the strengths of AEJ and TEJ were evaluated on these specific days to ascertain the characteristics of atmospheric dynamics during the occurrences of extreme rainfall events. The monsoon depth, the strengths of AEJ and TEJ are obtained by plotting the vertical wind profile using the U component of wind. The atmospheric dynamics of these events were diagnosed to find out the significant threshold of moisture flux, CAPE, vertical wind shear, monsoon depth, the strengths of AEJ and TEJ that may possibly be responsible for such unusually high amount of rainfall. Convective days were compared to a non-convective day to determine the difference in the characteristics of the atmospheric dynamics. Observationally, while there were occurrences of thunderstorms with heavy rainfall on convective days, none occurred on non-convective days. Ten weather events that produce rainfall above 50 mm were also selected for four meteorological stations over the northern region from 2010 to 2014. The mean of derived parameters such as moisture flux and CAPE 3 days prior and after the rainfall events are calculated to assess their characteristics during the period. (12.00°N, 8.59°E), Maiduguri (11.83 N, 13.15°E), Sokoto (13.01° N, 5.25°E), and Yelwa (10.83°N, 4.74°E) were chosen, because according to Omotosho (1985), about 90% of rainfall over these stations is attributed to MCSs.

### Computation of Horizontal Moisture Flux and Wind Shear

Horizontal moisture flux is computed by the following formula.

Using U and V components of wind,

$$\nabla \cdot \mathbf{V} = \frac{\partial \mathbf{u}}{\partial \mathbf{x}} + \frac{\partial \mathbf{v}}{\partial \mathbf{y}} \quad (1)$$

where  $\nabla \cdot \mathbf{V}$  = Divergence

Horizontal moisture flux divergence (HMFD) fields were derived from the specific humidity and components of the wind for the surface and 850 hPa by using the following formula:

$$\text{HMF} = - \left( U \frac{\partial \mathbf{q}}{\partial \mathbf{x}} + V \frac{\partial \mathbf{q}}{\partial \mathbf{y}} \right) + \mathbf{q} \left( \frac{\partial \mathbf{u}}{\partial \mathbf{x}} + \frac{\partial \mathbf{v}}{\partial \mathbf{y}} \right) \quad (2)$$

where:

$$\left( U \frac{\partial \mathbf{q}}{\partial \mathbf{x}} + V \frac{\partial \mathbf{q}}{\partial \mathbf{y}} \right) \text{ is the Advection term}$$

$$\left( \mathbf{q} \frac{\partial \mathbf{u}}{\partial \mathbf{x}} + \frac{\partial \mathbf{v}}{\partial \mathbf{y}} \right) \text{ is the divergence term}$$

where (q) is the specific humidity, (u) and (v) are zonal and meridional wind speed components of q, u and v; the advection term represents the horizontal advection of specific humidity, while the divergence term denotes the product of the specific humidity and horizontal mass convergence.  $\frac{\partial}{\partial \mathbf{x}}$  and  $\frac{\partial}{\partial \mathbf{y}}$  show the horizontal variation of atmospheric quantities such as specific humidity and wind. The first term in the moisture flux (MF) equation is moisture advection. This term incorporates changes of the moisture field with time or the flux of the moisture field. The moisture advection term, similar to the mass divergence term, incorporates into MF the effects of moisture availability on convection. The second term, mass convergence term incorporates moisture accumulation by multiplying the wind convergence, which is the rate at which the air itself is pooling, by the moisture content of the air (mixing ratio). The mass convergence term is usually the dominant term, and observations have shown that the moisture advection term can significantly contribute to the development and subsequent intensification of storms. By combining the effects of mass convergence as a low-level forcing mechanism with moisture availability, moisture flux incorporates most of the ingredients necessary for convection (Roshani et al. 2012).

Vertical wind shear ( $U_s$ ) was calculated using the zonal component of wind at 1000, 700, 400, and 200 hPa levels. The vertical wind shear ( $U_s$ ) is defined as:

$$U_s = \frac{d\mathbf{u}}{dz} \text{S}^{-1} \quad (3)$$

The vertical wind shear at the lower, mid, and upper troposphere using the formula (Omotosho 1987):

$$U_{S(L)} = U_{700} - U_{\text{surface}} \quad (4)$$

$$U_{S(M)} = U_{400} - U_{700} \quad (5)$$

$$U_{S(U)} = U_{200} - U_{400} \quad (6)$$

where:

$U_{S(L)}$  = Wind shear at lower troposphere

$U_{S(M)}$  = Wind shear at mid troposphere

$U_{S(U)}$  = Wind shear at upper troposphere

Rainfall events that produced rainfall above 50 mm were also selected for four meteorological stations over the northern Nigerian region from 2010 to 2014. The mean of derived moisture flux and CAPE 3 days prior and after the rainfall events were calculated to assess their characteristics during the period. Kano (12.00°N, 8.59°E), Maiduguri (11.83°N, 13.15°E), Sokoto (13.01°N, 5.25°E), and Yelwa (10.83°N, 4.74°E) were chosen, because according to Omotosho (1985), about 90% of rainfall over these stations is attributed to MCSs.

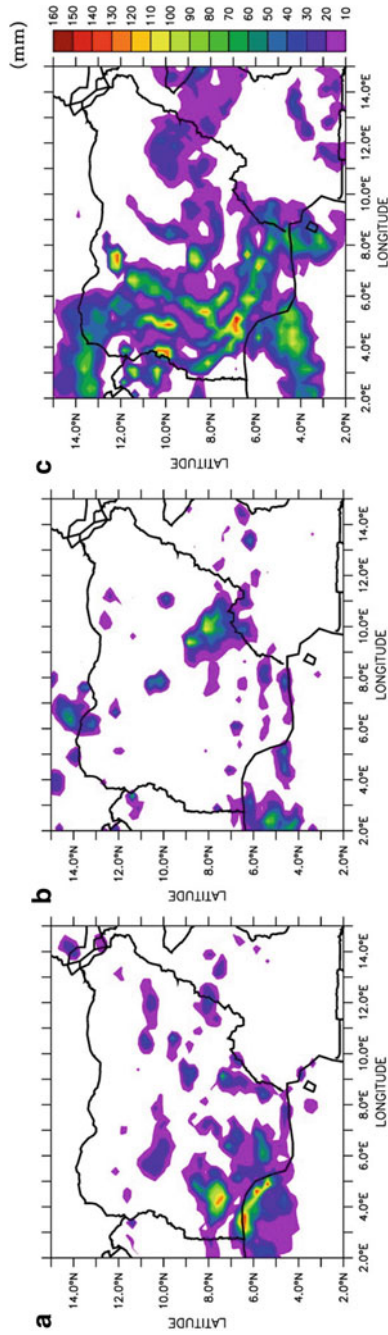
---

## Result

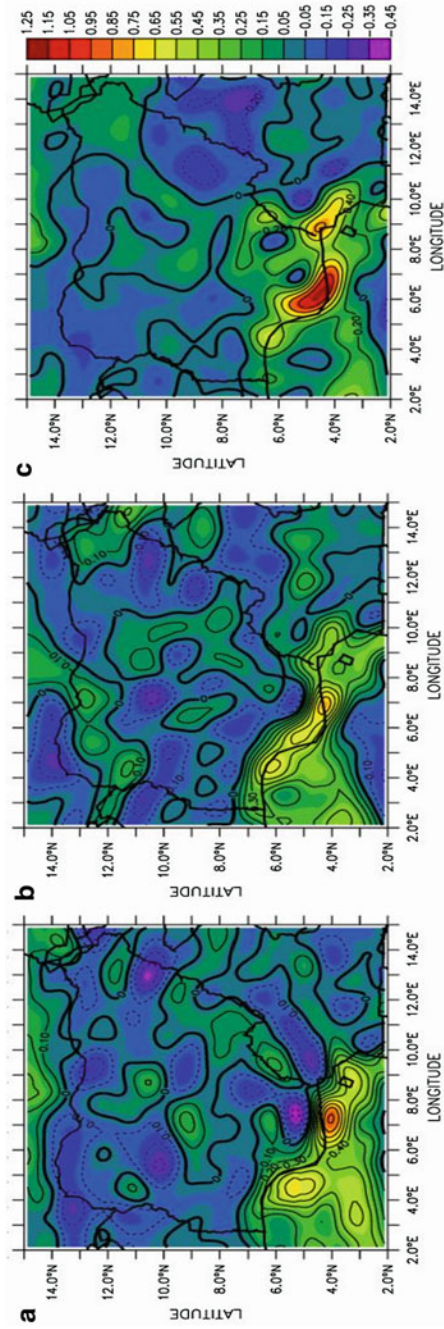
### Convective Days

#### Moisture Flux Analysis

The study presents the analysis of rainfall events that took place from the first to third July 2014 over most parts of the country. The intense rainfall observed led to flooding which resulted into loss of lives and properties. The TRMM rainfall analysis over the country from first to third as shown by Fig. 3a–c depicted the widespread rainfall across the country during the period. Rainfall amount of 71.5, 104, and 117 mm was observed on the first to third day, respectively, over Eket (4.65°N, 7.94°E), a coastal city in the southeastern part of the country. The horizontal moisture flux divergence (HMFD) analysis indicated that divergence of moisture at the surface was from the South Atlantic Ocean for the 3 days considered. Figure 4a–c showed that the values of HMFD ranged from 0.10 to  $1.05 \times 10^{-6} \text{ g kg}^{-1} \text{ s}^{-1}$  on the first day with slight reduction on the second day to  $0.85 \times 10^{-6} \text{ g kg}^{-1} \text{ s}^{-1}$  while the maximum value of HMFD on the third day was up to  $1.25 \times 10^{-6} \text{ g kg}^{-1} \text{ s}^{-1}$ . This analysis showed that higher the amount of moisture supplied to the storm, the higher the amount of precipitation. The analysis at 850 hPa level as shown by Fig. 5a–c depicted that area of moisture divergence shifted from the coast to mainly over the high grounds of Jos, Mambilla plateaus, and other high

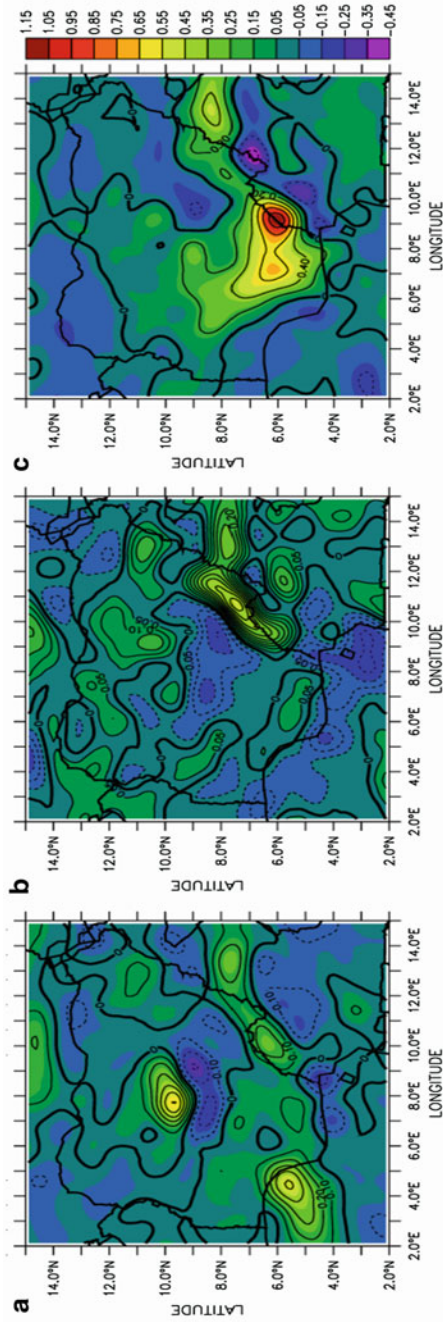


**Fig. 3** (a–c) Spatial distribution of TRMM rainfall (color; mm) for first, second, and third of July 2014, respectively, over Nigeria



**Fig. 4** (a–c) Spatial distribution of horizontal moisture flux divergence (HMF) at the surface (1000 hPa level) for 1–3 July 2014 (conversely, dotted lines indicate moisture convergence)





**Fig. 5 (a-c)** Spatial distribution of horizontal moisture flux divergence (HMF) at the 850 hPa for 1–3 July 2014 (conversely, dotted lines indicate moisture convergence)

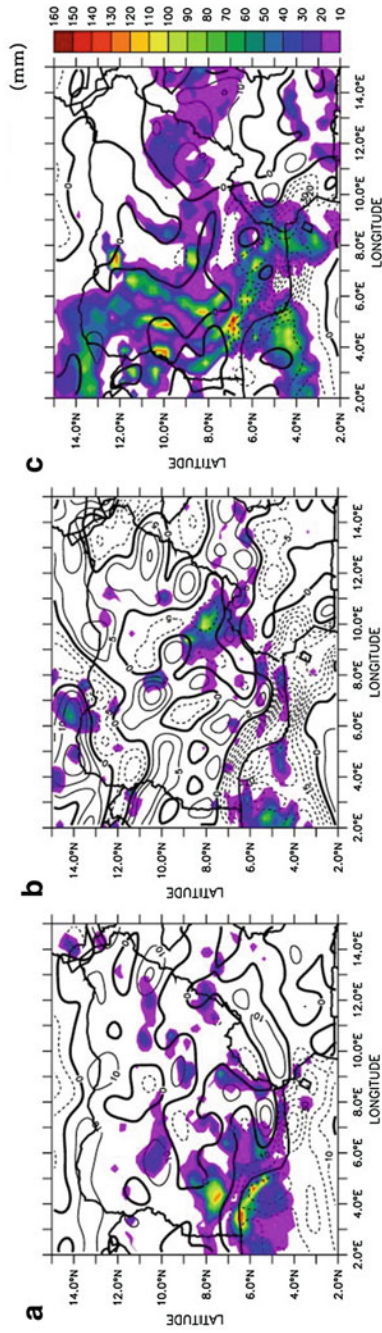
grounds across the country. Values of HMFD ranged from 0.01 to  $0.55 \times 10^{-6} \text{ g kg}^{-1} \text{ s}^{-1}$  on the first and second day and increased to  $1.15 \times 10^{-6} \text{ g kg}^{-1} \text{ s}^{-1}$  on the third day. It was observed that close to the divergence areas were areas of strong convergence, which coincided with areas of highest precipitation.

### Wind Divergence Analysis

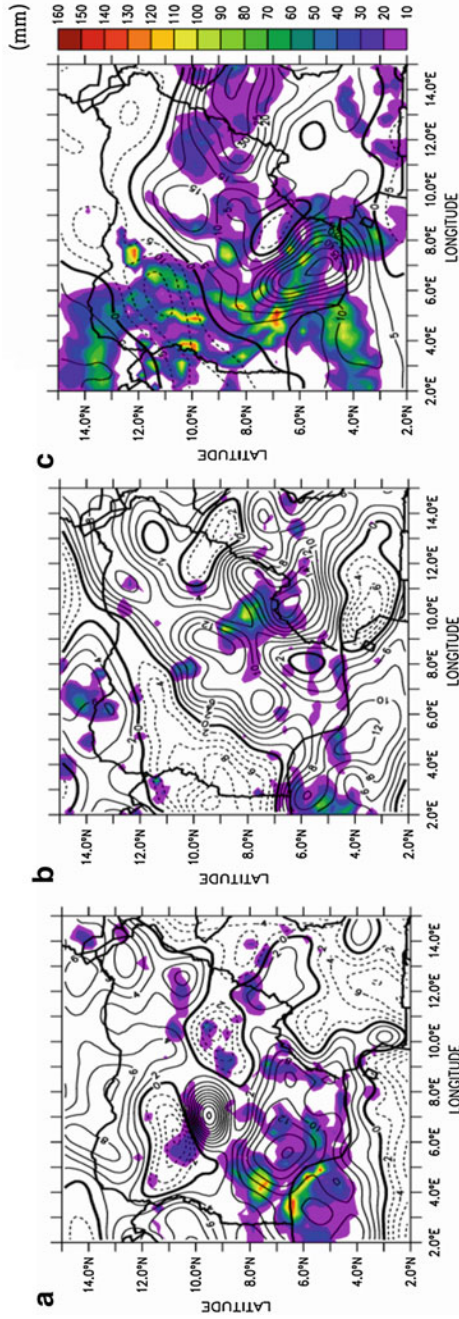
Figures 6a–c and 7a–c showed the observed rainfall distribution over the country was maximum along the coastal areas and some inland cities of the southwest, e.g., at Shaki (8.35°N, 5.47°E) on the first day, strong wind divergence at 200 hPa level exactly over this area enhanced the lower tropospheric wind convergence. This is consistent with Nicholson (2009) which stated that strong upper-level divergence is associated with strong upward motion and severe convective storms; in contrast, upper-level convergence usually indicates downward motion, which is a sign of decaying convection. Due to this strong divergence at the upper level, convection became vigorous and vertical transport of moisture was enhanced from the lower troposphere. However, Fig. 5b shows that along the coast, convergence was observed at the surface with corresponding divergence at 200 hPa with little amount of rainfall; this may also be attributed to insufficient moisture as shown by the moisture flux analysis. Similarly, over the western parts of the country, wind divergence was at the surface with corresponding convergence at 200 hPa, hence less precipitation was observed.

### Vertical Wind Shear

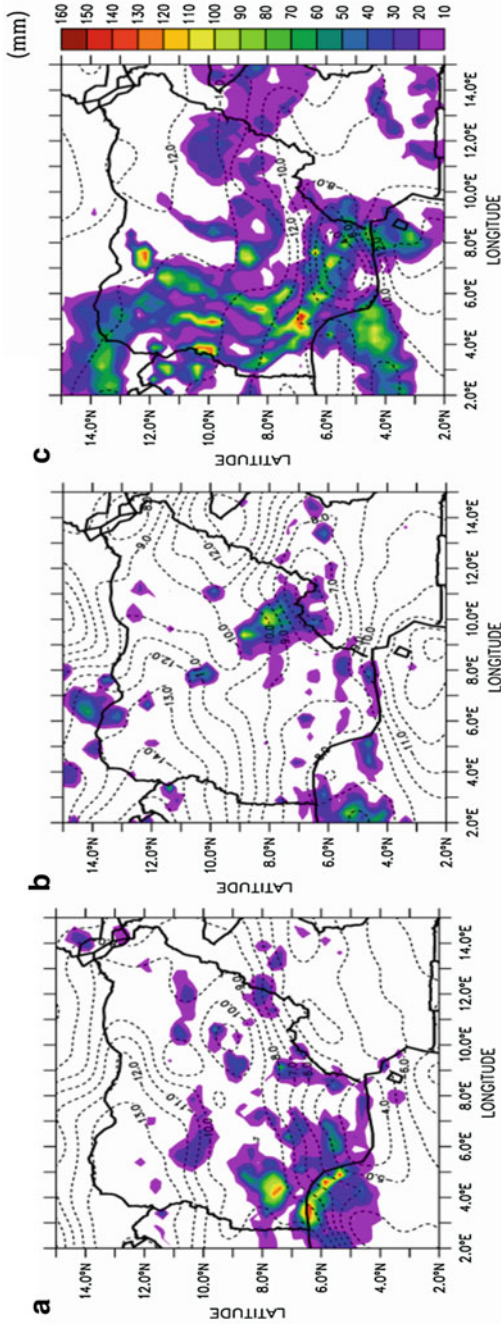
The wind shear analysis, Fig. 8a–c showed that the low-level wind shear  $U_{s(L)}$  ranged between  $-4 \text{ s}^{-1}$  and  $-14 \text{ s}^{-1}$  across the country. These values agreed with Omotosho (1987) who showed that thunderstorms occur most frequently in association with low-level shears, below the African Easterly Jet (i.e., surface to 700 hPa) with values within  $-20 \sim < U_{s(L)} \sim < -5 \text{ s}^{-1}$ . Areas with precipitation value above 50 mm have values of  $U_{s(L)}$  of  $-14 \text{ s}^{-1}$  and above. However, some areas with  $U_{s(L)}$  of  $-14 \text{ s}^{-1}$  did not record any rainfall, this may be attributed to wind divergence observed at the surface or inadequate moisture supply (Grist and Nicholson, 2001). The value of  $U_{s(L)}$  ranges from  $-8$  to  $-4 \text{ s}^{-1}$  over the southwest on the first and second day and up to  $-12 \text{ s}^{-1}$  on the third day. Considerable amount of rainfall observed over these regions coincided with areas with adequate moisture flux convergence on the first and third day. According to Rotunno et al. (1988) and Weisman et al. (1988), vertical wind shear is important in the formation of organized long-lived convection; however, very strong horizontal wind shear can inhibit the growth of cumulus clouds by blowing away the parts of the cloud containing the best developed precipitation particle and thereby preventing the process of precipitation (Rickenbach et al. 2002). Figure 8a–c showed that the value of mid-level wind shear  $U_{s(U)}$  over the country ranges between 0 and  $2 \text{ s}^{-1}$  except on the second day where the value of  $W_s U$  over western parts is between 0 and  $-10 \text{ s}^{-1}$ . It is noteworthy that moderately sheared environment is important for sustaining MCSs during extreme rainfall event (Figs. 9 and 10).



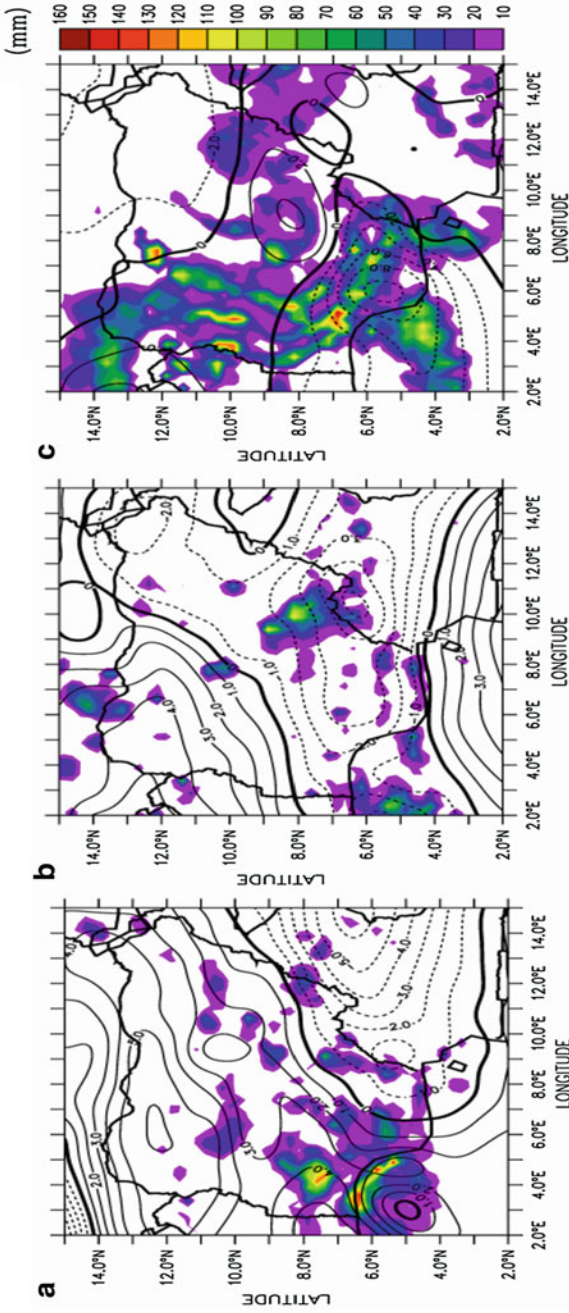
**Fig. 6** (a–c) Spatial distribution of rainfall (color; mm) and wind divergence at surface (contour;  $s^{-1}$ ) for 1–3 July 2014 (dotted lines indicate convergence)



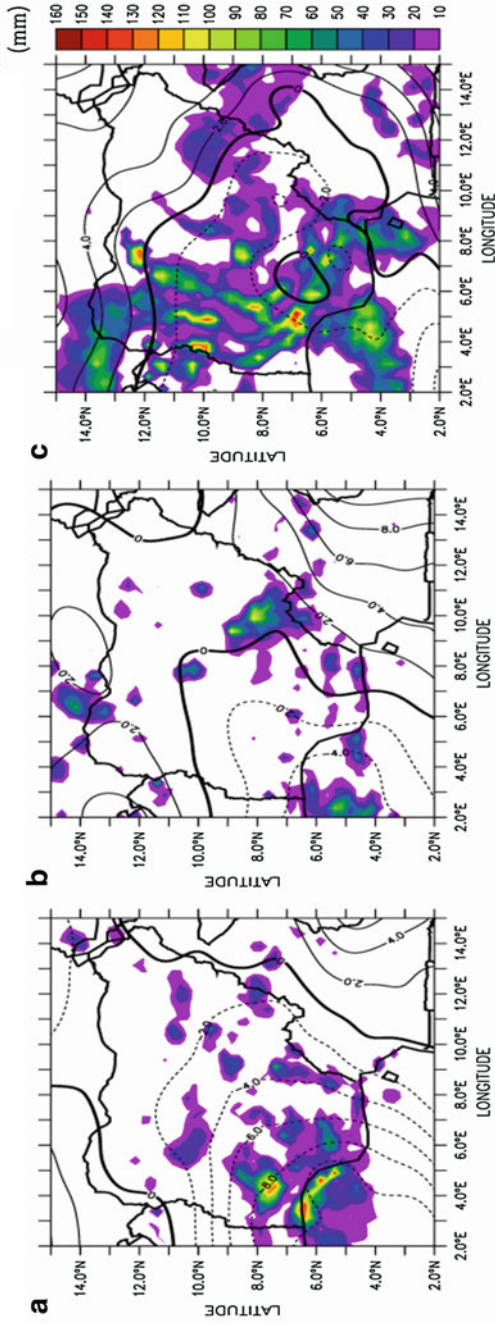
**Fig. 7** (a–c) Spatial distribution of Rainfall (color; mm) and wind divergence at 200 hPa (contour;  $s^{-1}$ ) for 1–3 July 2014 (dotted lines indicate convergence)



**Fig. 8** (a–c) Spatial distribution of low-level wind shear  $U_{S(L)}$  between the surface (1000 hPa) and 700 hPa level (contour;  $s^{-1}$ ) and TRMM precipitation (color; mm) for 1–3 July 2014



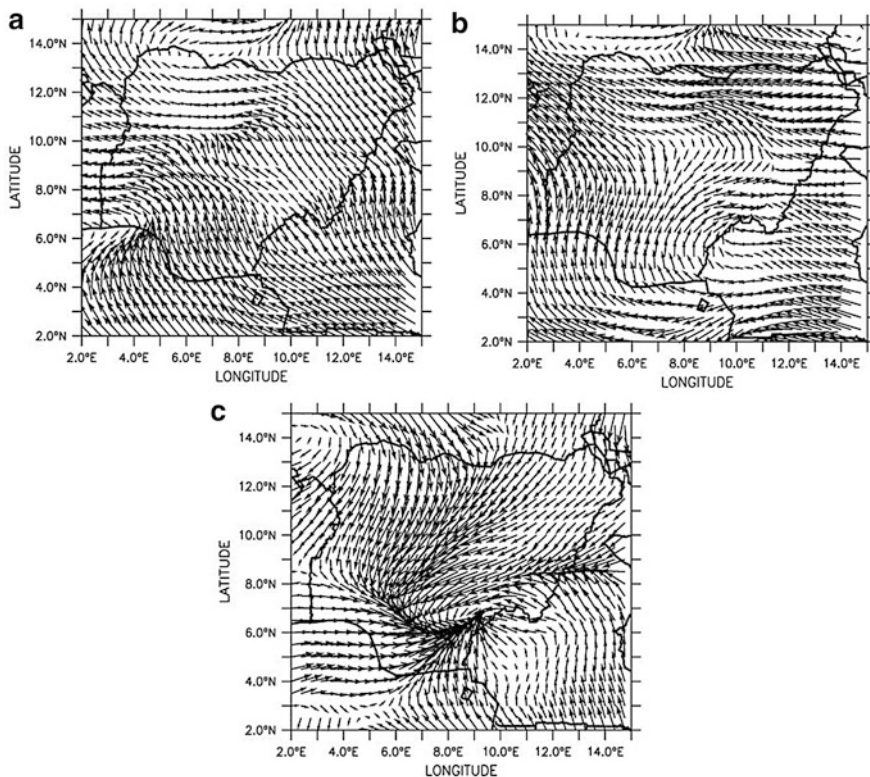
**Fig. 9** (a–c) Spatial distribution of upper-level wind shear  $U_{s(U)}$  between the 400 and 700 hPa level (contour;  $s^{-1}$ ) and TRMM precipitation (color; mm) for 1–3 July 2014



**Fig. 10** (a–c) Spatial distribution of upper-level wind shear  $U_{S(U)}$  between the 200 and 400 hPa level (contour;  $s^{-1}$ ) and TRMM precipitation (color; mm) for 1–3 July 2014

### Wind Vector at 850 hPa

Figure 11a–c showed that there was continuous moisture supply from the Atlantic Ocean throughout the rainfall events. Moist southwesterly winds convergence that was observed along the southwest coast on the first day produced significant amount of rainfall over Lagos ( $6.52^{\circ}\text{N}$ ,  $3.37^{\circ}\text{E}$ ) and Lokoja ( $7.80^{\circ}\text{N}$ ,  $6.73^{\circ}\text{E}$ ) axis. The wind flow from south to north remained steady from the day 1 and 2. Although over the northern parts, the wind direction indicated northeasterly flow on day 3, but sufficient residual moisture has already accumulated over the country up to the northern areas before the occurrence of a more widespread and heavy rainfall on the third day as shown by Fig. (11a–b). On the third day, over the southeastern parts, there was a well-organized deep monsoon flow from the Gulf of Guinea feeding into a vortex over the inland area of the southeastern parts of the country. The advected moisture depth was enough to maintain the active system over the southeastern axis as shown by the HMF $\text{D}$  analysis. A total rainfall of 292.5 mm was recorded round Eket ( $4.65^{\circ}\text{N}$ ,  $7.94^{\circ}\text{E}$ ), the vicinity of the vortex.



**Fig. 11** (a–c): Spatial distribution of wind vector at 850 hPa for 1–3 July 2014



### Convective Available Potential Energy (CAPE)

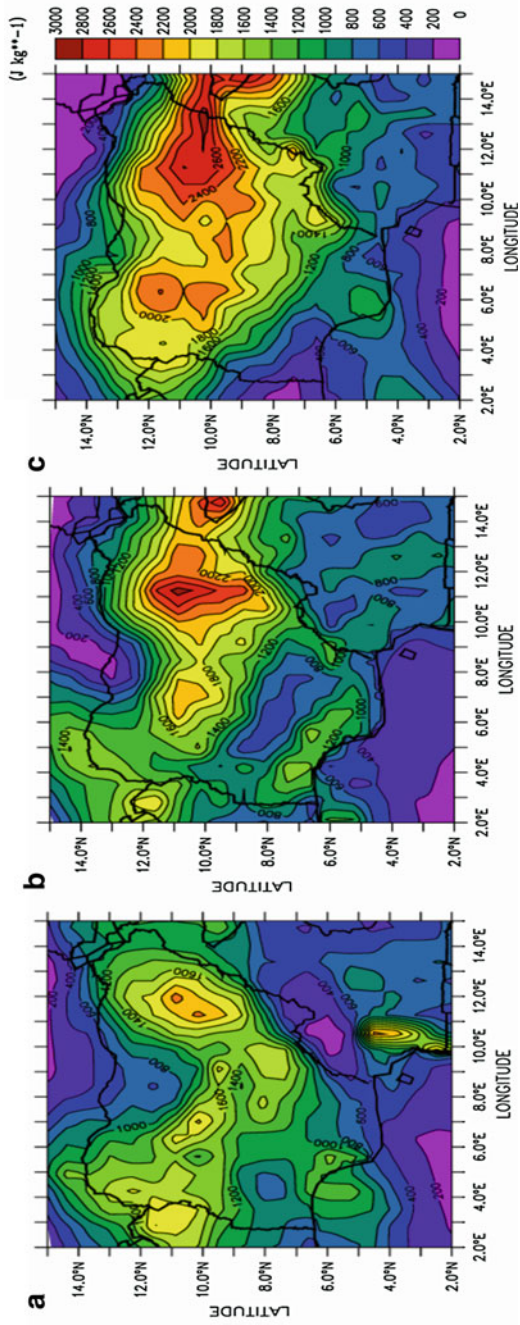
CAPE is an energy-based measure of atmospheric stability; it is a very important index in the forecasting of rainfall over Nigeria (Olaniyan et al. 2015). Figure 12a–c showed that the CAPE up to  $2900 \text{ Jkg}^{-1}$  was observed over the northeast and central parts in the first and second day; however, not much precipitation was recorded. This may also be attributed to insufficient moisture as shown by Fig. 4a–b. Over the southwest, CAPE value of  $1600 \text{ Jkg}^{-1}$  and  $2400 \text{ Jkg}^{-1}$  was observed on the first day and the second day, respectively, but due to reduction in moisture flux on the second day, rainfall reduction was observed compared to the first day. Over the southeastern parts, the CAPE values vary from  $800 \text{ JKg}^{-1}$  to  $1600 \text{ JKg}^{-1}$  and  $1000\text{--}1500 \text{ Jkg}^{-1}$  on the first and second day, respectively, while on the third day, the value ranged from  $1000 \text{ JKg}^{-1}$  to  $1500 \text{ JKg}^{-1}$ , and the highest amount of rainfall was observed on the third day. Over the northern parts, CAPE values favorable for convection ranges between  $1000$  and  $2800 \text{ Jkg}^{-1}$  on the first day, while it is  $600\text{--}3000 \text{ Jkg}^{-1}$  on the second day though no rainfall was observed on this day due to reduced moisture flux. On the third day, the CAPE value was  $2500 \text{ Jkg}^{-1}$  and peaked to  $4000 \text{ Jkg}^{-1}$ , higher rainfall was observed due to abundant moisture over this area indicating a deep layer of moisture to fuel the MCSs. A consistent pattern of CAPE was observed throughout the rainfall events, CAPE increases from coastal to the northern parts of Nigeria and the higher the CAPE, the higher the intensity of storm, provided moisture is sufficient.

### Vertical Wind Profile (AEJ, TEJ, and Monsoon Depth)

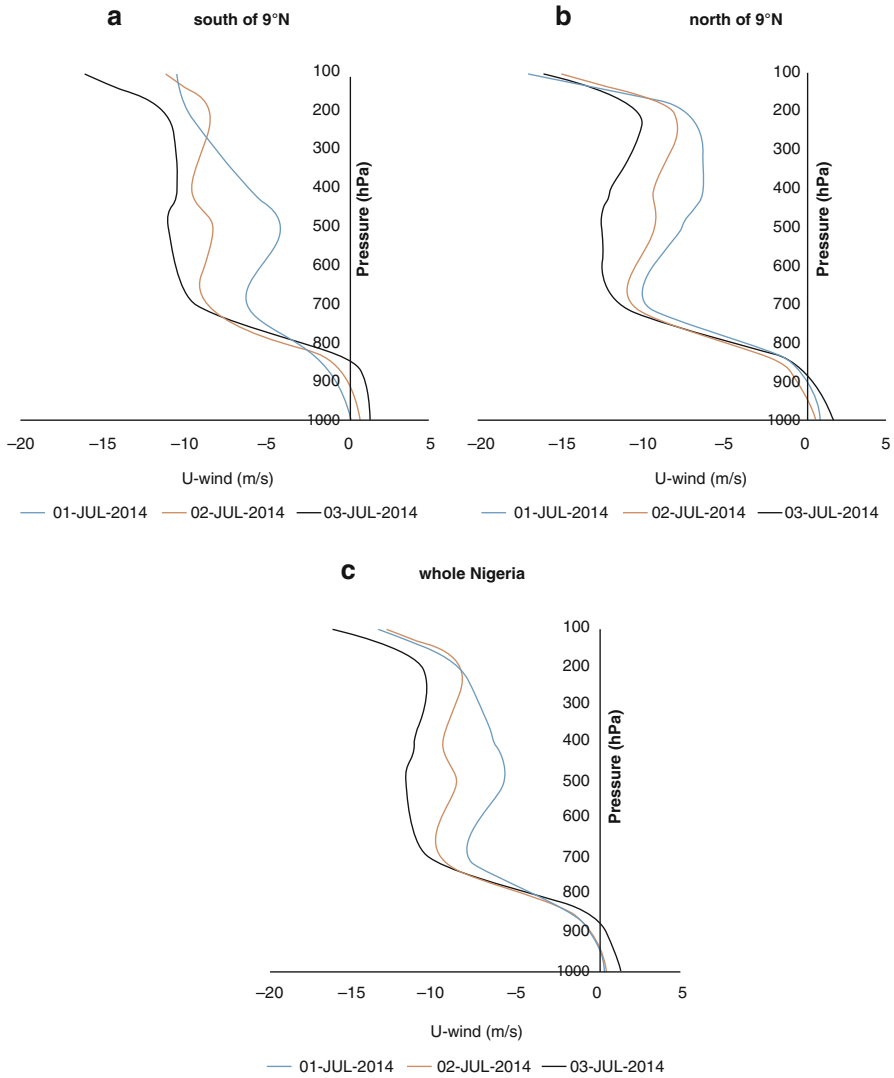
Figure 13a–c showed the extent of the moist southwesterly winds, the strength of the AEJ and the TEJ over the south and northern regions, and their mean position over the whole country, respectively, from the first to third of July. The zonal wind at the surface was westerly with speed of about  $2$ ,  $6$ , and  $5 \text{ ms}^{-1}$ , respectively, over the south of  $9^\circ\text{N}$ , north of  $9^\circ\text{N}$ , and the entire country. The first and second days indicated lower moisture depth at  $900 \text{ hPa}$  compared to  $950 \text{ hPa}$  on the third day (Fig. 13c). The AEJ was located at about  $700 \text{ hPa}$  with a mean speed of  $12$ ,  $10$ , and  $8 \text{ ms}^{-1}$  for the first, second, and third day, respectively, while the speed of TEJ was  $18$ ,  $12$ , and  $13 \text{ ms}^{-1}$ , respectively, for the 3 days over the entire country. Thermodynamically, the AEJ is often responsible for advection of both sensible heat and latent energy into regions where severe thunderstorms are formed. TEJ is responsible for enhancing upper level divergence, which in turn encourages vertical motion and lower level convergence (Nicholson et al. 2012). Therefore, the strength of the jets and the availability of adequate moisture support these extreme rainfall events.

### Non-convective Day

Generally, the atmosphere was stable on this day; most stations in the country reported no rainfall. Analysis of a non-convective day was done to evaluate the



**Fig. 12** (a–c). Spatial distribution of CAPE over Nigeria for 1–3 July 2014

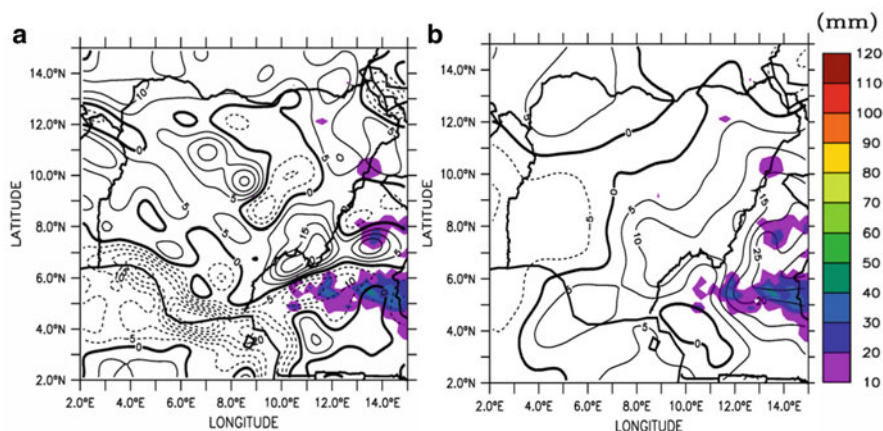


**Fig. 13** (a–c) Vertical wind profiles (in m/s) averaged over (a) south of 9°N, (b) north of 9°N, and (c) the entire Nigeria for 1–3 July 2014. Days 1, 2, and 3 are indicated in blue, red, and gray lines, respectively

difference in the behavior of the convective parameters in order to identify the reason for the observed stability in the atmosphere on the day.

**Divergence Analysis**

Figure 14a, b shows that over the southwestern parts of the country, convergence was observed at the surface and also at 200 hPa, and hence vertical motion was



**Fig. 14** Spatial distribution of rainfall (color; mm) and wind divergence at (a) 1000 hPa (b) 200 hPa level (contour;  $s^{-1}$ ) for 27 August 2014 (dotted lines indicate convergence)

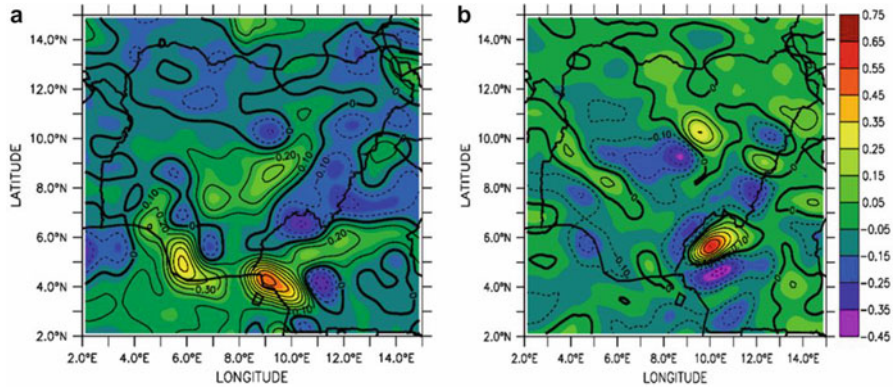
suppressed; this may be due to widespread subsidence prominent during this period caused by reduced sea surface temperature and the ridging effect of the south Atlantic high pressure system over the St. Helena. This period is usually referred to as the little dry season. However, over some parts of the central region and the southeastern coast, convergence was observed at the surface while there was corresponding divergence at 200 hPa, but no rainfall was observed; this may be due to lack of sufficient moisture as shown by the HMFD (as shown in the next section) analysis. The rest of the country was prevailed by convergence at 200 hPa while divergence was observed at the surface. These features could suppress vertical transport of moisture.

### Moisture Flux Analysis

The HMFD analysis at the surface in Fig. 15a shows that less moisture was available at the surface and 850 hpa level. Moisture flux diverging from the Atlantic Ocean at the surface over the southwest coast was almost negligible, while over the southeastern part extended from the coast even to the inland has values ranging from 0.10 to  $0.55 \times 10^{-6} \text{ kg/g s}^{-1}$ . Although wind convergence is present at the surface with corresponding divergence at 200 hPa, moisture may not be sufficient as shown in Fig. 14b, hence no rainfall is observed over the country.

### Vertical Wind Shear Analysis

Figure 16a–c shows that  $U_{S(L)}$  values ranged between  $0 \text{ s}^{-1}$  and  $-12 \text{ s}^{-1}$ . The value of  $U_{S(M)}$  across the country ranged from  $0 \text{ s}^{-1}$  to  $-8 \text{ s}^{-1}$ , zero value was observed over the central state, while the value of  $U_{S(U)}$  ranged from  $-8 \text{ s}^{-1}$  to  $-18 \text{ s}^{-1}$  as shown in Fig. 15a–c. Although this range is conducive for storm initiation, provided other conditions such as moisture availability, lower level convergence, and upper level divergence are met; otherwise, convection may be suppressed.



**Fig. 15** (a and b) Spatial distribution of horizontal moisture flux divergence (HMFD) at the surface (1000 hPa) and 850 hPa for 27 August 2014 (conversely, dotted lines indicate moisture convergence)

### Wind Vector

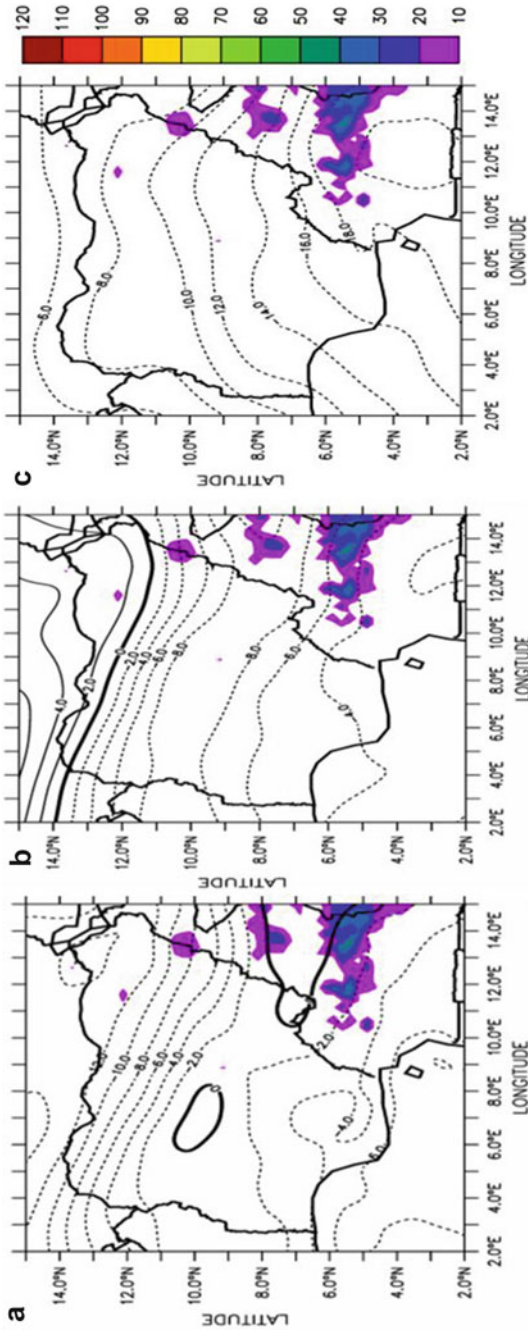
The wind vector analysis shown in Fig. 17 depicted the prevalence of southwesterly wind from the Atlantic Ocean, but no rainfall was over the country; this was confirmed by insufficient moisture as shown in the moisture flux analysis of Fig. 15a, b despite the fact that the entire country was prevailed by southwesterly winds, and no rainfall was recorded across the country. According to Omotosho and Abiodun (2007), little or no precipitation is observed below a certain limit of atmospheric moisture.

### Convective Available Potential Energy (CAPE)

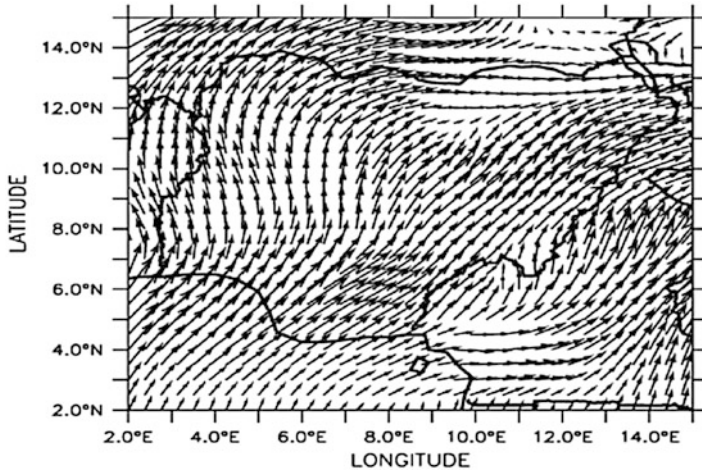
Figure 18 shows that the CAPE across the country ranges between  $200 \text{ Jkg}^{-1}$  in the south and  $1200 \text{ Jkg}^{-1}$  over the north; this is an indication of less potential energy to support convection, and for this particular day, moisture was also not sufficient to support rainfall as shown by HMFD analysis (Fig. 15a, b).

### Mean HMFD and CAPE at the Surface, Three Days Prior and Three Days After Storm Events

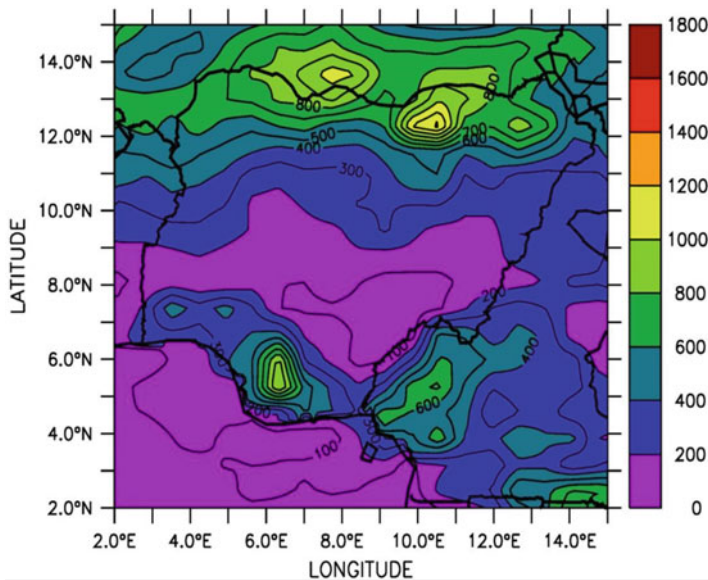
Ten weather events that produce rainfall above 50 mm were selected for four meteorological stations over the northern Nigeria from 2010 to 2014. The mean of derived parameters for selected days namely, horizontal moisture flux divergence (HMFD) and CAPE were evaluated 3 days before and 3 days after the storm over the northern stations of Kano ( $12.00^\circ\text{N}$ ,  $8.59^\circ\text{E}$ ), Maiduguri ( $11.83^\circ\text{N}$ ,  $13.15^\circ\text{E}$ ), Sokoto ( $13.01^\circ\text{N}$ ,  $5.25^\circ\text{E}$ ), and Yelwa ( $10.83^\circ\text{N}$ ,  $4.74^\circ\text{E}$ ) depicted in Figs. 19a, b, 20a, b, 21a, b, and 22a, b, respectively. On these figures, horizontal axes represent days; with 0 representing the day of the stormy events while negative and positive values (day) represent, respectively, 3 days prior and 3 days after the storm. Generally,



**Fig. 16** (a–c) Spatial distribution of low-level wind shear: (a) 700–1000 hPa ( $U_{S(700)}$ ), and (c) 200–400 hPa ( $U_{S(200)}$ ) level (contour;  $s^{-1}$ ) and TRMM precipitation (color; mm) for 27 August 2014

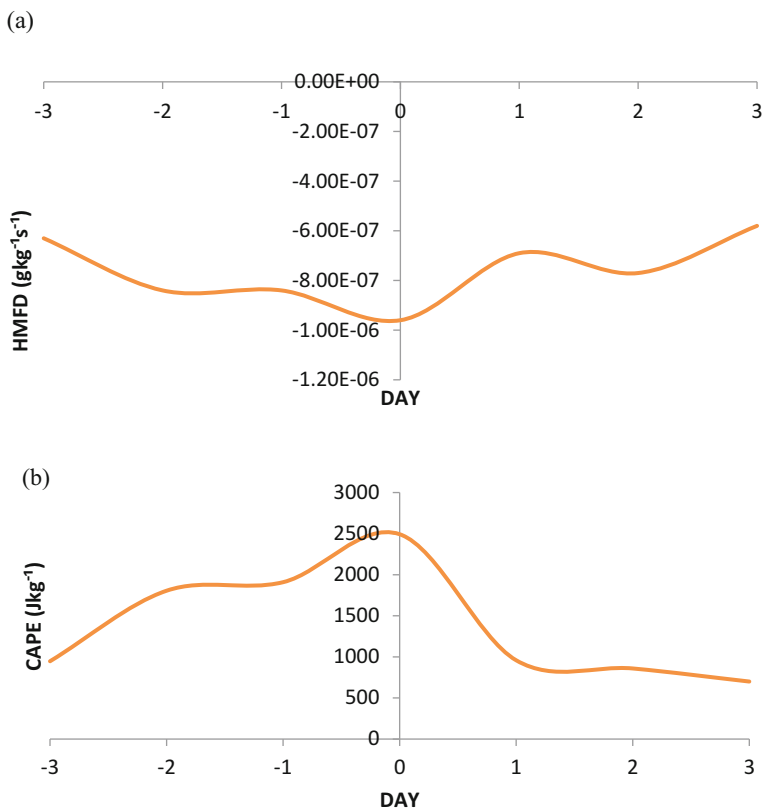


**Fig. 17** Spatial distribution of wind vector over Nigeria at 850 hPa for 27 August 2014



**Fig. 18** Spatial distribution of CAPE over Nigeria for 27 August 2014

moisture divergence from the Atlantic Ocean accumulates prior to the storm, reaches climax on the day of the rainfall event, and starts declining after the storm (Panel (a) of Figs. 19, 20, 21, and 22). The mean HMGD was highest on day 0 which is day of the rainstorm. This is depicted by negative moisture flux and afterwards it gradually decreased after the storm. The analysis showed that extreme rainfall events are characterized by significant moisture flux divergence prior to storm events. Panel



**Fig. 19** (a and b) Derived meteorological parameters at surface over Kano (3 days before and 3 days after extreme rainfall events from June to September 2010–2014) for (a) mean HMFD and (b) CAPE

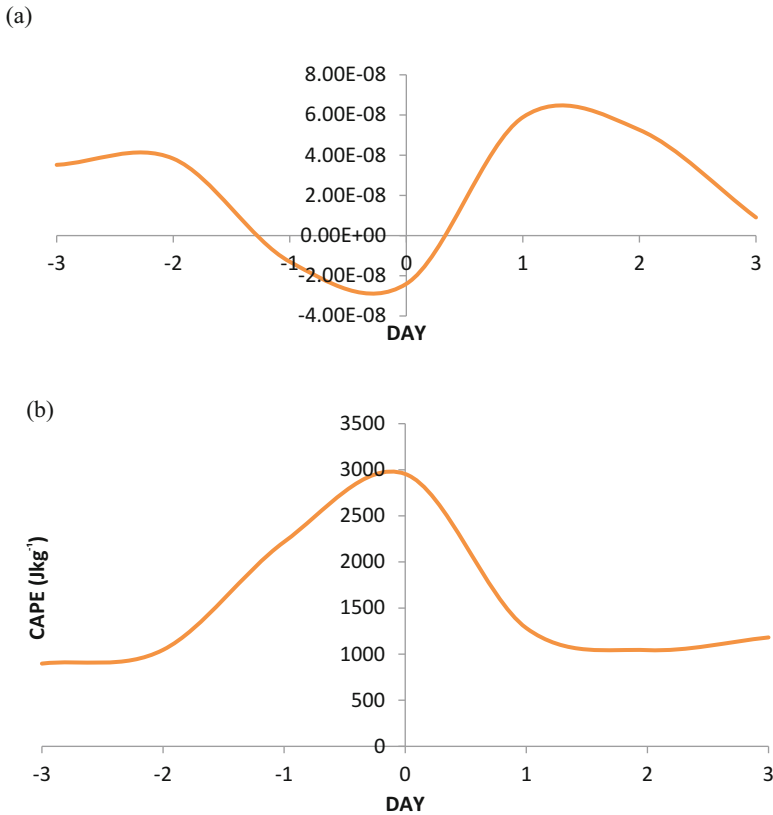
(b) of Figs. 19, 20, 21, and 22 also showed a similar pattern for the mean CAPE analysis.

Table 1 shows the mean CAPE on day 0, which ranges from 2416 Jkg<sup>-1</sup> to 2954 Jkg<sup>-1</sup> with the highest over Sokoto.

## Conclusion

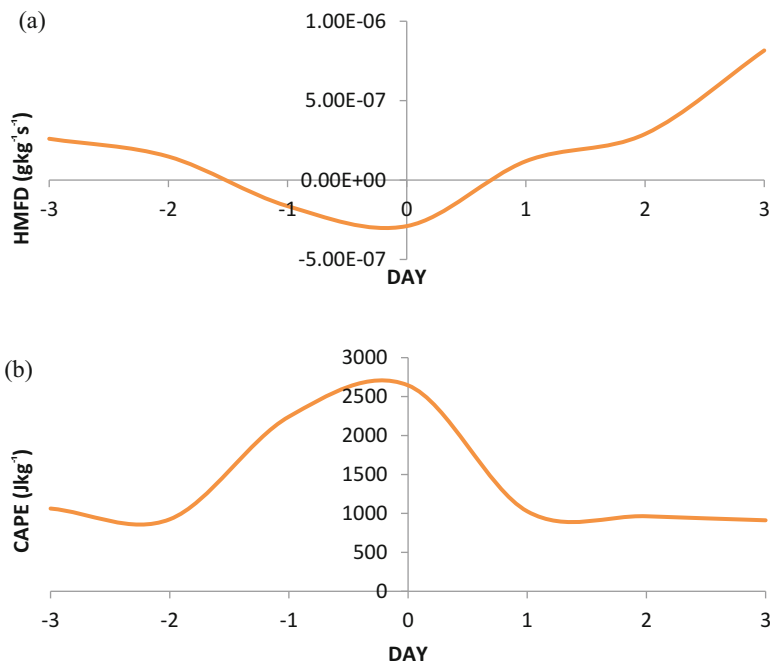
This chapter identified and examined a set of severe widespread rainfall that produced flood events over different parts of Nigeria. The result showed that moisture, convective instability, vertical wind shear, and lifting mechanisms all contributed to these events, but most importantly, the moisture influx. The quantity of rainfall over a given area can be related to the magnitude of the lower tropospheric moisture flux. The study also showed that the transfer of moisture flux in the low layer is mainly from the South Atlantic Ocean, and the higher the moisture flux diverged from the





**Fig. 20** (a and b) Derived meteorological parameters at surface Sokoto (3 days before and 3 days after the storm for extreme events from June to September 2010–2014) for (a) mean moisture flux divergence and (b) CAPE. Negative values in moisture flux analysis indicate convergence while positive values indicate divergence

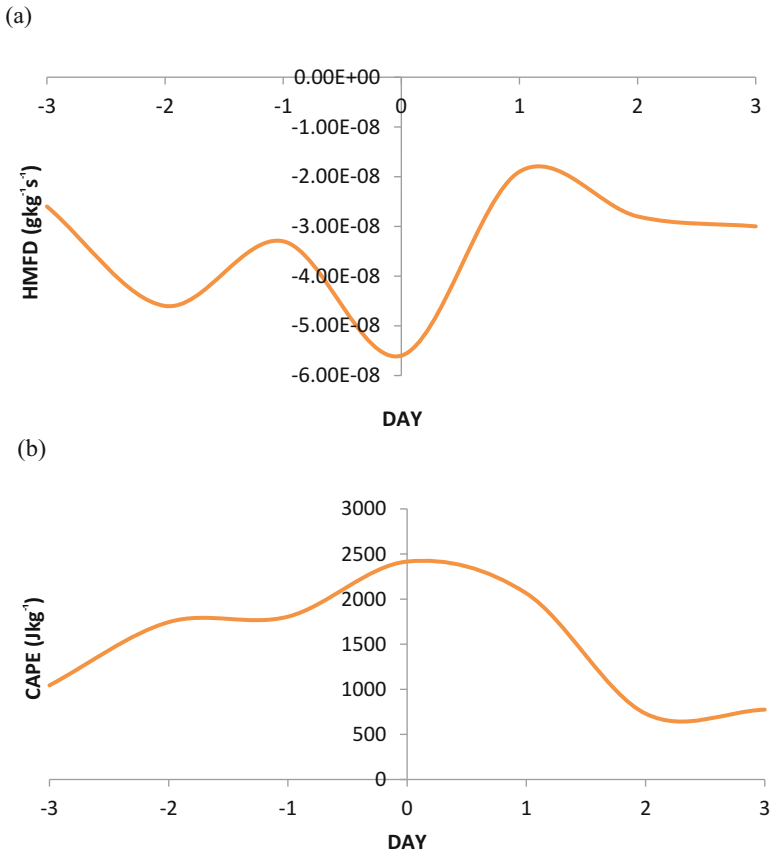
Atlantic Ocean, the higher the amount of rainfall. The result also indicated that low-level convergence that corresponds with upper-level divergence encourages vertical transport of moisture while low-level divergence and upper-level convergence results in subsidence. At the surface, the value of moisture flux divergence ranges between  $0.05$  and  $1.15 \times 10^{-6} gkg^{-1} s^{-1}$  at the vicinity of areas where considerable amount of precipitation of above  $50$  mm were observed. They are mostly located westward of moisture divergence zone. This gives a good indication of where flood is most likely. Moisture flux divergence value ranged from  $1.0$  to  $2.0 \times 10^{-6} gkg^{-1} s^{-1}$  at  $850$  hpa around the areas with substantial amount of rainfall in its vicinity, the high grounds of the southwest, Jos, Mambila, Adamawa plateaus, and Cameroonian mountain are good source of moisture divergence at  $850$  hPa, and hence these area can be referred to as fertile ground for convection (Hodges and Thorncroft 1997; Akinsanola and Ogunjobi 2014). The wind shear below the AEJ ( $U_{S(L)}$ ) over



**Fig. 21** (a and b) Derived meteorological parameters at surface over Maiduguri (3 days before and 3 days after extreme rainfall events from June to September 2010–2014) for (a) mean moisture flux divergence and (b) CAPE. Negative values in moisture flux analysis indicate convergence while positive values indicate divergence

the region of intense precipitation ranges between  $-8$  and  $-12 \text{ ms}^{-1}$ . At mid-troposphere ( $U_{S(M)}$ ), wind shear value ranged from  $2 \text{ s}^{-1}$  to  $-8 \text{ s}^{-1}$ , while at upper level ( $U_{S(U)}$ ), the values ranged between  $0$  and  $12 \text{ s}^{-1}$ . Most of the result of  $U_{S(L)}$  were in agreement with Omotosho (1987) on the value of wind shear necessary for the initiation and sustenance of MCSs.

The CAPE analysis indicated that potential energy equal or greater than  $1500 \text{ J kg}^{-1}$  favored convection over the northern parts, while CAPE value equal or greater  $1000 \text{ J kg}^{-1}$  was able to trigger convective activities over the southern parts. The result also showed that extreme rainfall also depends on convective available potential energy CAPE, and the higher the CAPE, the more intense was the rainfall, provided moisture was sufficient. Similarly, rainfall observed at a particular area varies according to the amount of moisture flux advected by the monsoon winds into the area. The mean moisture flux and CAPE analysis for extreme storm events over selected cities in northern Nigeria indicated that there is always an increase in the value of moisture flux and CAPE 3 days prior to storm occurrences. This can be a good indicator for forecasting extreme rainfall events. Table 1 shows the peak values of mean CAPE and moisture flux over the selected northern Nigerian stations. The result also shows that sufficient CAPE and wind



**Fig. 22** (a and b) Derived meteorological parameters at surface over Yelwa (3 days before and 3 days after extreme rainfall events from June to September 2010–2014) for (a) mean moisture HMFD and (b) CAPE

**Table 1** Peak values of mean derived meteorological parameters at the surface HMFD and CAPE over Kano, Maiduguri, Sokoto, and Yelwa for JJAS (2010–2014)

STATIONS	HMFD (gKg <sup>-1</sup> s <sup>-1</sup> )	CAPE (Jkg <sup>-1</sup> )
KANO	-9.60E-07	2492
MAIDUGURI	-2.90E-07	2644
SOKOTO	-2.40E-08	2954
YELWA	-5.60E-08	2416

shear is not enough for convection, it is necessary to have sufficient amount of moisture for initiation and sustenance of the storm throughout its life. These observed pattern of wind flow at the surface and 850 hPa, the CAPE and HMFD when sighted on the forecast charts may be good indicators for forecasting extreme

rainfall and the likelihood of flood events which will help in early preparedness and prevention of the worst impacts of such extreme events on lives and properties.

A further study of moisture flux and wind shear is recommended using different operational models and more network of stations as this will give a better perception of impact of moisture flux on spatial rainfall variability across the country. Forecasting precipitation amount is a challenging task for forecasters, therefore adequate study of the criteria such as moisture flux, wind shear, and CAPE will increase the understanding of extreme rainfall events; though there will always be variability in the values of meteorological parameters, sound understanding of forecast models, learning how to analyze the situation using the appropriate tools, and knowing how to apply these tools will give the best chance of predicting extreme events and issuing timely warnings.

---

## References

- Akinsanola AA, Ogunjobi KO (2014) Analysis of rainfall and temperature variability over Nigeria. *Glob J Hum-Soc Sci*: B 14(3):11–17
- Bechtold P, Chaboureaud J-P, Beljaars A, Betts AK, Kohler M, Miller M, Redelsperger JL (2004) The simulation of the diurnal cycle of convective precipitation over land in a global model. *Q J Roy Meteor Soc* 130:3119–3137
- Beckman SK (1990) A study of 12 h NGM low-level moisture flux convergence centers and the location of severe thunderstorms/heavy rain. In: Proceedings of the 16th AMS conference on severe local storms, Kananaskis Park, Alta, pp 78–83
- Bello NJ (2010) Impacts of climate change on food security in sub-Saharan Africa. In: Proceedings of the 14th Annual Symposium of the International Association of Research Scholars and Fellows, IITA, Ibadan, pp 13–25
- Couvreur F, Guichard F, Bock O, Campstron B, Lafore JP, Redelsperger JL (2010) Synoptic variability of the monsoon flux over West Africa prior to the onset. *Q J R Meteorol Soc* 136 (1):159–173
- Diatta S, Fink AH (2014) Statistical relationship between remote climate indices and West African monsoon variability. *Int J Climatol* 34:3348–3367
- Enete IC (2014) Impacts of climate change on agricultural production in Enugu State, Nigeria. *J Earth Sci Clim Change* 5(9):234. <https://www.omicsonline.org/open-access/impacts-of-climate-change-on-agricultural-production-in-enugu-state-nigeria-2157-7617.1000234.php?aid=32633>
- Grist JP, Nicholson SE (2001) A study of the dynamic factors influencing the rainfall variability in the West African Sahel. *J Clim* 14(7):1337–1359
- Hodges KI, Thorncroft CD (1997) Distribution and statistics of African mesoscale convective weather systems based on the ISCCP Meteosat imagery. *Mon Weather Rev* 125:2821–2837. [https://doi.org/10.1175/1520-0493\(1997\)125<2821:DASOAM>2.0.CO;2](https://doi.org/10.1175/1520-0493(1997)125<2821:DASOAM>2.0.CO;2)
- IPCC (2014) Synthesis report. In: Core Writing Team, Pachauri RK, Meyer LA (eds) Contribution of working groups I, II and III to the fifth assessment report of the Intergovernmental Panel on Climate Change. IPCC, Geneva, 151pp
- Janicot S, Caniaux G, Chauvin F, De Coëtlogon G, Fontaine B, Hall N (2011) Intraseasonal variability of the West African monsoon. *Atmos Sci Lett* 12(1):58–66
- Lawal KA, Abatan AA, Anglil O, Olaniyan E, Olusoji Victoria H, Oguntunde PG, Lamptey B, Babatunde JA, Shiogama H, Michael FW, Dith AS (2016) The late onset of the 2015 wet season in Nigeria. *BAMS* 97:63–69. <https://doi.org/10.1175/BAMSD-16-0131.1>

- Madu IA (2016) Rurality and climate change vulnerability in Nigeria: assessment towards evidence based even rural development policy. Paper presented at the 2016 Berlin conference on global environmental change, 23–24 May 2016 at Freie Universität Berlin. [https://pdfs.semanticscholar.org/508b/94cab07b84a703b44eca1089326cc98d7495.pdf?\\_ga=2.154518008.112403230.1572433568-162569160.1557482164](https://pdfs.semanticscholar.org/508b/94cab07b84a703b44eca1089326cc98d7495.pdf?_ga=2.154518008.112403230.1572433568-162569160.1557482164)
- Nicholson SE (2009) A revised picture of the structure of the “monsoon” and land ITCZ over West Africa. *Clim Dyn* 32(7–8):1155–1171
- Nicholson SE (2013) The West African Sahel: a review of recent studies on the rainfall regime and its interannual variability. *Int Scholar Res Notices* 2013:453521, 32 p. <https://doi.org/10.1155/2013/453521>
- Nicholson SE, Klotter DA, Dezfuli AK (2012) Spatial reconstruction of semi-quantitative precipitation fields over Africa during the nineteenth century from documentary evidence and gauge data. *Quat Res* 78:12–23
- NiMet Climate Review Bulletin (2018) Nigerian Meteorological Agency 2019
- Nwankwoala HNL (2015) Causes of climate and environmental changes: the need for environmental-friendly education policy in Nigeria. *J Educ Pract* 6(30). <http://www.iiste.org>. ISSN 2222–1735 (Paper) ISSN 2222–288X (Online)
- Nyakwada W (2004) The challenges of forecasting severe weather and extreme climate events in Africa WMO WSHOP-SEEF/Doc.4(4)
- Okorie FC (2015) Analysis of 30 years rainfall variability in Imo state of South-Eastern Nigeria. In: *Hydrological sciences and water security: past, present and future*. IAHS Press, Wallingford, pp 131–132
- Olaniyan E, Afesimama EOF, Lawal KA (2015) Simulating the daily evolution of West African monsoon using high resolution regional Cosmo-model: a case study of the first half of 2015 over Nigeria. *J Climatol Weather Forecast* 33:3–8
- Omotosho JB (1985) The separate contributions of squall lines, thunderstorms and the monsoon to the total rainfall in Nigeria. *J Climatol* 5:543–552
- Omotosho JB (1987) Richardson number, vertical wind shear, and storm occurrences over Kano Nigeria. *Atmos Res* 21:123–137
- Omotosho JB, Abiodun BJ (2007) A numerical study of moisture build-up and rainfall over West Africa. *Meteorol Appl* 14:209–225
- Omotosho JB, Balogun AA, Ogunjobi K (2000) Predicting monthly and seasonal rainfall, onset and cessation of the rainy season in West Africa using only surface data. *Int J Climatol* 20:865–880
- Raj J, Bangalath HK, Stenchikov G (2019) West African monsoon: current state and future projections in a high-resolution AGCM. *Clim Dyn* 52:6441–6461. <https://doi.org/10.1007/s00382-018-4522-7>
- Rickenbach TM, Ferreira RN, Halverson J, Silva Dias MAF (2002) Mesoscale properties of convection in Western Amazonia in the context of large-scale wind regimes. *J Geophys Res Atmos* 107:8040
- Roshani A, Fateme P, Zahra H, Hooshang G (2012) Studying the moisture flux over South and Southwest of Iran: a case study from December 10 to 13, 1995 rain storm. *Earth Sci Res* 2(2):2013
- Rotunno R, Klemp JB, Weisman ML (1988) A theory for strong long lived squall lines. National Center for Atmospheric Research Boulder, Colorado, pp 463–483
- Sultan B, Janicot S (2003) The West African monsoon dynamics. Part II: the “preonset” and “onset” of the summer monsoon. *J Clim* 16:3407–3427
- Sumi SM, Zaman MF, Hirose H (2012) A rainfall forecasting method using machine learning models and its application to the Fukuoka City case. *Int J Appl Math Comput Sci* 22(4):841–854
- Weisman ML, Rotunno R (2004) A theory for strong long-lived squall lines revisited. *J Atmos Sci* 61:361–382. [https://doi.org/10.1175/1520-0469\(2004\)061<0361:ATFSL>2.0.CO;2](https://doi.org/10.1175/1520-0469(2004)061<0361:ATFSL>2.0.CO;2)
- Weisman ML, Klemp JB, Rotunno R (1988) Structure and evolution of numerically simulated squall lines. *J Atmos Sci* 45:1990–2013

**Open Access** This chapter is licensed under the terms of the Creative Commons Attribution 4.0 International License (<http://creativecommons.org/licenses/by/4.0/>), which permits use, sharing, adaptation, distribution and reproduction in any medium or format, as long as you give appropriate credit to the original author(s) and the source, provide a link to the Creative Commons license and indicate if changes were made.

The images or other third party material in this chapter are included in the chapter's Creative Commons license, unless indicated otherwise in a credit line to the material. If material is not included in the chapter's Creative Commons license and your intended use is not permitted by statutory regulation or exceeds the permitted use, you will need to obtain permission directly from the copyright holder.





# Plastic Pollution and Climate Change: Role of Bioremediation as a Tool to Achieving Sustainability

# 57

S. A. Idowu, D. J. Arotupin, and S. O. Oladejo

## Contents

Introduction .....	1160
Polyethylene Terephthalate (PET): A Typical Plastic .....	1160
Plastic Waste and Environmental Pollution .....	1161
Climate Change .....	1163
Bioremediation .....	1163
In Situ and Ex Situ Bioremediation .....	1164
Organisms Involved in Bioremediation .....	1164
Bioremediation of Polyethylene Terephthalate (PET) .....	1165
Conclusion .....	1167
References .....	1167

## Abstract

Pollution from post-consumer plastics is a growing global environmental challenge whose negative impacts are exacerbating climate change. Plastics are stable, durable, and hydrophobic. They possess high molecular weight, complex three-dimensional structure, and are not readily available to be used as substrate by biological agents such as microorganisms and enzymes. Polyethylene terephthalate (PET) is one of the examples of petrochemical-based plastics. PET is a strong, clear, and light-weight plastic with global usage in the production of bottles.

This chapter was previously published non-open access with exclusive rights reserved by the Publisher. It has been changed retrospectively to open access under a CC BY 4.0 license and the copyright holder is “The Author(s)”. For further details, please see the license information at the end of the chapter.

S. A. Idowu (✉) · D. J. Arotupin  
Department of Microbiology, Federal University of Technology, Akure, Nigeria

S. O. Oladejo  
Department of Remote Sensing and Geoscience Information System, Federal University of Technology, Akure, Nigeria

Technological innovation, policy formulation, advocacy and sensitization, change in consumption pattern, and bioremediation are some of the approaches that are currently being used to mitigate environmental pollution from post-consumer PET bottles. The ubiquitous property of microorganisms and their ability to survive in almost every environment, including very extreme ones, make them good candidate for biodegradation. Bioremediation is simply defined as engineered or enhanced biodegradation. This review discusses the potential of bioremediation as sustainable and environment-friendly tool to clean up post-consumer PET bottles that already accumulate on land, in soil, and in water bodies.

---

**Keywords**

Bioremediation · Plastic · Pollution · Climate change · Biodegradation

---

**Introduction**

Plastic is a group of substances with wide global usages and applications as a consumer product. Plastic possesses characteristic cheap price, light weight, and disposable nature which make them the substance of choice in the manufacturing industry. However, plastic pollution is a growing global environmental challenge to aquatic, celestial, and terrestrial organisms including man. The current increasing global human population and technological developments are among the major factors contributing to increasing significant snowballing quantity of plastic waste that is generated annually. This increase exacerbates environmental pollution due to unsustainable methods of disposal of post-consumer (or used) plastics. Accumulation of post-consumer plastics on the surface of the earth including those that are buried in the earth is a serious threat to environmental safety and human health. In general, plastics possess characteristic stable, durable, and hydrophobic nature. They possess high molecular weight, complex three-dimensional structure, and are not readily available to be used as a substrate by many biological agents such as microorganisms and enzymes (Arutchelvi et al. 2008; Kale et al. 2015). As a result of the above, plastics accumulate over a very long period of time. (Kenny et al. 2008) reported that an efficient decomposition of plastic takes about 1,000 years.

---

**Polyethylene Terephthalate (PET): A Typical Plastic**

Polyethylene terephthalate (PET) is one of the examples of petrochemical-based plastics. PET is a thermoplastic polyester (Hosseini et al. 2005). It is a strong, clear, and light weight plastic with global usage in the production of bottles. The PET bottles are used for packaging drinks, other food products, and pharmaceuticals. In the field of engineering, PET is being used as alternative or replacement for metals like aluminum, steel, and other metals in the manufacture of precision moldings for office appliances, domestic appliances, and electrical and electronic devices (Hosseini et al. 2005; Tanasupawat et al. 2016; Yoshida et al. 2016). Polyethylene





**Fig. 1** Typical example of a bottle made from polyethylene terephthalate (PET). (Source: <https://www.shutterstock.com/image-photo/top-view-empty-plastic-bottle-isolated-572688928>)

terephthalate is a polyester (polymer) produced by polymerization reaction. The reaction involves two monomers, namely terephthalic acid (TPA) and ethylene glycol (EG) according to (Kale et al. 2015). A typical example of bottle made of PET is presented in Fig. 1 below.

The presence of aromatic groups in the PET molecule makes PET nondegradable under normal condition according to the report of (Hosseini et al. 2005). The biological degradation of PET was thought to be limited to only a few fungal species and as a result biodegradation was earlier considered as not yet a remediation strategy for PET (Tanasupawat et al. 2016).

---

## Plastic Waste and Environmental Pollution

The traditional methods (such as burning in the open field) used to dispose of post-consumer plastics, especially in developing countries, is a global environmental concern. Smoke, containing dioxins, furans, mercury, and polychlorinated biphenyls which are injurious to health and the environment, is released into the atmosphere during open burning of plastics, thereby leading to air pollution which consequently contributes to climate change (Webb et al. 2013). In addition, most post-consumer PET bottles end up in landfills where they persist and occupy huge land space, thereby impairing soil fertility with subsequent negative impact on agricultural practice (Chan 2016; Kale et al. 2015). Some post-consumer PET bottles are burnt in open fire during which they release carbon dioxide (CO<sub>2</sub>) and dioxins into the atmosphere, also exacerbating environmental pollution and climate change (Kenny et al. 2008; Tanasupawat et al. 2016). Increasing efforts are being made globally to address environmental pollution from PET wastes. Other toxic and hazardous pollutants from plastic wastes are highlighted in the report of (Webb et al. 2013).

Measures and approaches that are currently being used to mitigate plastic pollution include the following:

- Technological innovations (e.g., bioplastics)
- Policies (e.g., ban of single-use plastics and green shopping)
- Change in consumption pattern and different “Rs” including *reduction*, *reuse*, and *recycling* of post-consumer plastics
- Advocacy/sensitization (e.g., The 2018 World Environment Day with the theme “*Plastic Pollution*”).
- Bioremediation (Gnanavel et al. 2012; Hadad et al. 2005; Hosseini et al. 2005; Ron and Eugene 2014; Sardrood et al. 2013; Yoshida et al. 2016)

It is practically impossible to totally eradicate the use of plastics for domestic and industrial uses, neither is it possible not to generate post-consumer plastics due to vast properties of plastics that make them suitable for various domestic and industrial uses. This therefore means that wastes from post-consumer plastics will be generated continually as long as man exists on earth. This waste is projected to increase with the increasing global human population.

Several approaches have been identified to mitigate environmental pollution from post-consumer plastics. However, two of the approaches are majorly relevant to this discourse. The first is a total removal of PET bottles which constitute environmental nuisance. This can be achieved through sustainable clearing of PET bottles that have been used and dumped, mostly in indiscriminate manner, from the surface of the earth or from water bodies. The second approach is replacing plastics of non-biological origin with plastics that are made from biological agents. The latter are commonly referred to as bioplastics. Bioplastics are produced or synthesized from biomass or renewable resources according to the report of (Sardrood et al. 2013). They have been identified to be more readily available for bioremediation than nonbioplastics, thereby preventing accumulation on the environment for a very long period of time. Technology is involved in the production of bioplastics to harness the biomass and other raw materials that are employed in the production. This special type of technological process that involves biological agent is called biotechnology (Sardrood et al. 2013). Detailed discussion of types of biotechnology and the processes involved in each of the types are beyond the scope of this chapter.

Technological advancements and scientific researches toward development and improvement on bioplastics are growing globally. This biotechnology will help to produce plastics that will be readily available for easy degradation by microorganisms, thereby proving solution to environmental and climatic problems that are associated with accumulation of post-consumer plastics. As this biotechnology develops to gain worldwide popularity and acceptance to displace nonbioplastics in circulation, it is important to provide suitable sustainable approach to get rid of post-consumer plastics, particularly PET bottles that are already exacerbating environmental pollution and climate change. A biological approach will be appropriate for this remediation as it is usually environment friendly (Gnanavel et al. 2012; Hosseini et al. 2005). The interesting ability of microorganisms to survive in almost every environment including very extreme ones together with their ubiquitous property makes them a good candidate for bioremediation. Bioremediation is a form of biotechnology which involves engineering. This essence of engineering

the process is to enhance the capacity of the microorganisms being used and to make the process faster (Borasiya and Shah 2007; Hadad et al. 2005).

---

## Climate Change

Climate change (natural and human induced) is real. Industrialization and human desire for development and better living, which are carried out sometime in an unsustainable way, affect the environment and natural resources negatively, thereby exacerbating climate change. The realization of this challenge by the General Assembly of the United Nations gave birth to establishment of Brundtland Commission. The Commission in their report tagged *Our Common Future* and submitted to the UN General Assembly in 1987, and identified that both environment and development are inseparable, nevertheless sustainable development must be encouraged in every human development as a means of saving the earth. This development, described popularly as sustainable development, embraces and encourages development that equally promotes economy, social, and environmental developments without prejudice to any of the three members (Burton 1987). Any development whose economic, environmental, and social benefits are not equally addressed is unsustainable and this was part of the recommendation of the commission. Unsustainable consumption of PET bottles is a potential economic, social, and environmental problem that can increase climate change.

---

## Bioremediation

According to (Baggot 1993; Boopathy 2000) in (Sardrood et al. 2013), bioremediation is a process of using living organisms or biological processes to clean up contaminated environments by exploiting and harnessing metabolic abilities of microorganisms to convert contaminants into harmless products by mineralization, generation of carbon (IV) oxide and water, or by conversion into microbial biomass. Bioremediation as evolving environmental biotechnology uses microorganisms in the degradation process and can be optimized to achieve better result (Borasiya and Shah 2007). Some of the numerous applications of bioremediation include cleanup of ground water, sludges, lagoons, and process-waste stream (Boopathy 2000). Practically, bioremediation has been used on a large-scale application in cleanup of oil spill from Exxon in Prince William Sound, Alaska (Kenny et al. 2008). Some of the advantages of bioremediation have been reported (Boopathy 2000; Sardrood et al. 2013).

Microorganisms have the ability to break the molecular chains in polymers like the PET through degradation. Degradation is one of the many processes involved in bioremediation (Sardrood et al. 2013), this means that a biodegradation activity may not result into total bioremediation. The break in molecular chains during biodegradation leads to decrease in the total length of macromolecules that make the polymer and the degree of polymerization (Fig. 3) as contained in the report of (Hosseini et al. 2005).

---

## In Situ and Ex Situ Bioremediation

One of the advantages of bioremediation in management and treatment of wastes is that the process can be carried out at site of contamination or somewhere away from site of contamination. Based on the above, bioremediation can be classified as in situ bioremediation and ex situ bioremediation. The former involves treatment of the contaminated material within the site where contamination or pollution has occurred, while ex situ technique of bioremediation involves physical removal of the contaminant or pollutant from the site of pollution for treatment (Boopathy 2000). In situ bioremediation is usually used in cleanup of oil spills. However, in treating pollutants such as post-consumer PET bottles, ex situ bioremediation may be used.

---

## Organisms Involved in Bioremediation

Bioremediation involves the use of microorganisms in the remediation process. Pollution from post-consumer plastics can be noticed in the air, on land, and in water bodies such as sea and oceans. The natural ability of microorganisms to degrade hydrocarbons, though at a relatively slow rate, makes them suitable candidates for bioremediation. What scientists do is to simply optimize and harness the natural potential of such microorganisms through biotechnology. (Ron and Eugene 2014; Sardrood et al. 2013) highlight how certain species of microorganisms were used to clean oil spills. Several species of fungi, bacteria, and plants are major organisms that have been identified and reported to be involved in bioremediation. There are specific conditions that enhance bioremediation. The conditions must be provided in order for bioremediation process to proceed as planned and expected. According to (Kenny et al. 2008; Ron and Eugene 2014), these favorable conditions include the following:

1. The organism shall be able to live and demonstrate its bioactivity under conditions of pollution
2. A consortium of microorganism that can successfully utilize the pollutant as a substrate must be present
3. Contaminant and the enzymatic system must come in close contact somewhere in or out of the cell
4. The organisms will have the effective enzymes that are important in bioremediation
5. Appropriate favorable environmental conditions must exist or be provided to enhance multiplication of the potential organism to be used for bioremediation

(Boopathy 2000) summarized the key conditions that affect bioremediation as microbial and environmental substrate, aerobic and anaerobic process, growth substrate and co-metabolism physico-chemical bioavailability of pollutants, and mass transfer limitations.

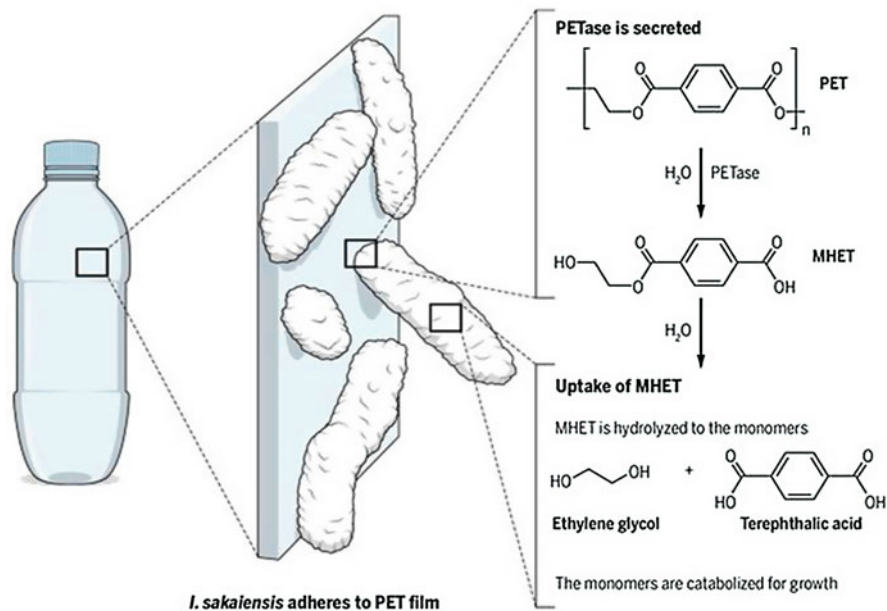
## Bioremediation of Polyethylene Terephthalate (PET)

The discovery of the bacterium *Ideonellasakaiensis* 206-F6<sup>T</sup> signified another scientific development in bioremediation of PET. The discovery presented *I. sakaiensis* as one of the many microorganisms whose potentials can be harnessed to remediate environmental pollution from post-consumer PET bottles that are disposed indiscriminately. The fungus *Pseudozyma jejuensis* isolated from leaves of *Citrus unshiu* in South Korea earlier before the isolation of *I. sakaiensis*, has also been demonstrated to possess remarkable plastic-degrading potential as reported by (Tanasupawat et al. 2016). The fungus possesses the enzyme cutinase which has the ability to degrade some plastics according to (Tanasupawat et al. 2016). Despite the plastic-degrading potential of *P. jejuensis*, the organisms were not reported to degrade PET. This development clearly indicates the need to isolate specific microorganisms that are suitable to degrade each of the large groups of plastics that constitute environmental pollution. This necessitated the need for more scientific researches to isolate microorganisms that possess the ability to utilize PET as their source of carbon. The bacterium, *I. sakaiensis*, is important in bioremediation of post-consumer PET bottles that constitute environmental pollution (Yoshida et al. 2016). According to the report of (Tokiya et al. 2009; Yoshida et al. 2016), the bacterium showed high PET-degrading potential when compared with previously isolated microorganisms. The authors highlighted factors that favor the bioremediation process in order to achieve optimum result (Fig. 2).

Reports of (Webb et al. 2013; Yoshida et al. 2016) explained that *I. sakaiensis* 206-F6<sup>T</sup> possesses critical enzymes that are needed in the degradation of PET. The enzymes include PETase and MHETase. *I. sakaiensis* 206-F6<sup>T</sup> uses the two



**Fig. 2** Images of plastic pollution on both terrestrial and aquatic environment. (a) Dump site showing plastic pollution. (Source: <https://www.alamy.com/garbage-dump-plastik-bottles-pet-bottles-image281712766.html>). (b) Plastic pollution of marine environment. (Source: Saving Earth Encyclopaedia Britannica)



**Fig. 3** Schematic degradation of PET bottle by *I. sakaiensis* strain 206-F6<sup>T</sup>. (Source: (Chan 2016))

enzymes to metabolize PET as its major carbon source (Fig. 3). PETase is a type of esterase and it initiates breaking of the long ester bonds in PET through hydrolytic activity. Esterase is an enzyme that has the ability to break ester bond in a compound. The hydrolytic activity PETase produces an intermediate called mono(2-hydroxyethyl) terephthalic acid (MHET) as presented in Fig. 3 below. The intermediate that results from the hydrolytic breakdown is taken back by the cell of *I. sakaiensis* 206-F6<sup>T</sup> and is further hydrolyzed by the second enzyme MHETase. The responsibility of MHETase in the degradation process is to break the intermediate into the monomers of PET (Caruso 2015; Tokiwa et al. 2009; Yoshida et al. 2016). The two monomers are named Terephthalic acid (TPA) and ethylene glycol (EG). The report of (Chan 2016) showed that *I. sakaiensis* 206-F6<sup>T</sup> damaged PET film extensively and almost completely degraded the film after 6 weeks at temperature of 30 °C.

In natural environments, PET bottles, like other plastics, are exposed to UV radiation. The radiation causes cleavage of the C—C bond of the polymer, thereby leading to the formation of low molecular weight fragments. This process increases the susceptibility of the polymer to microbial attack (Arutchelvi et al. 2008). This may be one of the reasons why (Yoshida et al. 2016) used low-crystalline (1.9%) PET film in their study as free-flying plastic bottles in nature may be of a higher crystalline percentage than the ones used by the authors in their research.

## Conclusion

The above discourse shows that there are several options to reducing environmental pollution from post-consumer plastics in general and PET bottles in specific. However, bioremediation still stands tall as an important evolving option for sustainable remediation of post-consumer plastics. Other approaches such as discouraging unsustainable consumption of plastics and formulation and implementation of research-informed policies also need to be encouraged as a mean to reducing environmental pollution from plastics.

Microorganisms have the natural potential to use petroleum products including plastics as their sources of carbon and energy, thereby helping to reduce the menace of plastic pollution within the environment and subsequently mitigating climate change. The natural potential of microorganisms can be engineered and optimized through biotechnology as the sustainable way to “clean up” plastic pollution that threatens life on land, water, and air.

It is recommended that in order to further contribute to knowledge on harnessing the potential of microorganisms isolated from PET bottle recycling sites to degrade PET bottles, there is the need to test such microbial isolates with PET film of high crystalline value and be sure that the microorganisms can sufficiently hydrolyze the film. This is to ensure wider global acceptability of the technology because the PET bottles that are used to package food, drinks, and pharmaceutical products are made from high crystalline PET.

---

## References

- Arutchelvi J, Sudhakar M, Arkatkar A, Doble M, Bhaddur S, Uppar PV (2008) Biodegradation of polyethylene and polypropylene. *Indian J Biotechnol* 7:9–22
- Baggot J (1993) Biodegradable lubricants. In: Sardrood BP, Goltapeh EM, Varma A (eds) An introduction to bioremediation: fungi as bioremediators. [https://doi.org/10.1007/978-3-642-33811-3\\_1](https://doi.org/10.1007/978-3-642-33811-3_1)
- Boopathy R (2000) Factors limiting bioremediation technologies. *Bioresour Technol* 74:63–67
- Borasiya H, Shah MP (2007) Waste water treatment by environmental microbiology. *J Bioremed Biodegr*. <https://doi.org/10.4172/2155-6199.1000386>
- Burton I (1987) Report on reports: our common future. *Environ Sci Policy Sustain Dev* 29(5):25–29. <https://doi.org/10.1080/00139157.1987.9928891>
- Caruso G (2015) Plastic degrading microorganisms as a tool for bioremediation of plastic contamination in aquatic environments. *J Pollut Eff Cont*. <https://doi.org/10.4172/2375-4397.1000e112>
- Chan A (2016) The future of bacteria cleaning our plastic waste. *Berkeley Sci J*. <https://doi.org/10.5772/48612>
- Gnanavel G, Valli VPMJ, Thirumarimurugan M (2012) A review of biodegradation of plastics waste. *Int J Pharm Chem Sci* 1(3):1019–1022
- Hadad D, Geresh S, Sivan A (2005) Biodegradation of polyethylene by the thermophilic bacterium *Brevibacillus borstelensis*. *J Appl Microbiol* 98:1093–1100
- Hosseini SS, Taheri S, Zadhoush A, Mehrabani-Zeinabad A (2005) Hydrolytic degradation of poly(ethylene terephthalate). *J Appl Polym Sci* 102:2304–2309
- Kale SK, Deshmukh AG, Dudhare MS, Patil VB (2015) Microbial degradation of plastic: a review. *J Biochem Tech* 6(1):952–961

- Kenny ST, Runic JN, Kaminsky W, Woods T, Babu RP, Keely CM, Blau W, O'Connor KE (2008) Up-cycling of PET (polyethylene terephthalate) to the biodegradable plastic (poly-hydroxyalkanoate). *Environ Sci Technol* 42(20):7696–7701
- Ron E, Eugene R (2014) Enhanced bioremediation of oil spills in the sea. *Curr Opin Biotechnol* 27:191–194
- Sardrood BP, Goltapeh EM, Varma A (2013) In: Goltapeh (ed) *Fungi as bioremediators, soil biology*. [https://doi.org/10.1007/978-3-642-33811-3\\_1](https://doi.org/10.1007/978-3-642-33811-3_1)
- Tanasupawat S, Takehana T, Yoshida S, Hiraga K, Oda K (2016) *Ideonellasakaiensis* sp. nov., isolated from a microbial consortium that degrades poly (ethylene terephthalate). *Int J Syst Evol Microbiol* 66:2813–2818
- Tokiwa YA, Calabria BP, Ugwu CU, Aiba S (2009) Biodegradability of plastics. *Int J Mol Sci* 10:3722–3742
- Webb HK, Amott A, Crawford RJ, Ivanova EP (2013) Plastic degradation and its environmental implications with special reference to poly(ethylene terephthalate). *Polymers* 5:1–18
- Yoshida S, Hiraga K, Takehana T, Taniguchi I, Yamaji H, Maeda Y, Toyohara K, Miyamoto K, Kimura Y, Oda K (2016) A bacterium that degrades and assimilates poly(ethylene terephthalate). *Science* 351(6278):1196–1199

**Open Access** This chapter is licensed under the terms of the Creative Commons Attribution 4.0 International License (<http://creativecommons.org/licenses/by/4.0/>), which permits use, sharing, adaptation, distribution and reproduction in any medium or format, as long as you give appropriate credit to the original author(s) and the source, provide a link to the Creative Commons license and indicate if changes were made.

The images or other third party material in this chapter are included in the chapter's Creative Commons license, unless indicated otherwise in a credit line to the material. If material is not included in the chapter's Creative Commons license and your intended use is not permitted by statutory regulation or exceeds the permitted use, you will need to obtain permission directly from the copyright holder.







# Climate Change, Rural Livelihoods, and Ecosystem Nexus: Forest Communities in Agroecological zones of Nigeria

# 58

Olushola Fadairo, Samuel Olajuyigbe, Tolulope Osayomi, Olufolake Adelakun, Olanrewaju Olaniyan, Siji Olutegbe, and Oluwaseun Adeleke

## Contents

Introduction .....	1170
Forest Livelihoods and the Challenge of Changing Climate .....	1172
Agriculture, Climate Change, and Food Security .....	1174
Climate Change and Drivers of Social Vulnerability in Nigeria .....	1174
Theoretical Framework .....	1175
Sustainable Livelihood Framework .....	1175
Chapter Approach .....	1177
Effects of Climate Variability on Cropping Calendar in Mangrove, Rainforest, and Savannah Agroecological Zones of Nigeria .....	1179
Perceived Trend in Agriculture, Forest Area, and Population as Primary Drivers of Social Vulnerability .....	1183
Perceived Effects of Drivers of Climate Change on Household Livelihood .....	1185

This chapter was previously published non-open access with exclusive rights reserved by the Publisher. It has been changed retrospectively to open access under a CC BY 4.0 license and the copyright holder is “The Author(s)”. For further details, please see the license information at the end of the chapter.

O. Fadairo (✉) · O. Adelakun · S. Olutegbe · O. Adeleke  
Department of Agricultural Extension and Rural Development, University of Ibadan, Ibadan, Nigeria  
e-mail: [dairom2@gmail.com](mailto:dairom2@gmail.com); [flakyonline@yahoo.com](mailto:flakyonline@yahoo.com); [siji004u@yahoo.com](mailto:siji004u@yahoo.com); [aladeoluwaseun@yahoo.com](mailto:aladeoluwaseun@yahoo.com)

S. Olajuyigbe  
Department of Forest Production and Products, University of Ibadan, Ibadan, Nigeria  
e-mail: [lekito2001@yahoo.com](mailto:lekito2001@yahoo.com)

T. Osayomi  
Department of Geography, University of Ibadan, Ibadan, Nigeria  
e-mail: [osayomi@yahoo.com](mailto:osayomi@yahoo.com)

O. Olaniyan  
Department of Economics, University of Ibadan, Ibadan, Nigeria  
e-mail: [lanreolaniyan@yahoo.co.uk](mailto:lanreolaniyan@yahoo.co.uk)

Causes and Consequences of Environmental Degradation in the Nigeria Agroecological Zones .....	1186
Farming Communities' Needs for an Enduring Adaptation to Climate Change in Nigeria .....	1188
Conclusion and Recommendation .....	1189
References .....	1190

## Abstract

A top-bottom approach where local problems are treated in isolation has proven ineffective in achieving sustainable development. The need for inclusive approaches to managing the demand for arable lands, forest resources, and the problems of resource exploitation and climate change calls for local understanding of these elements' interrelationship. Understanding the interrelationships among climate change, agriculture, and the ecosystems in different agroecological zones in Nigeria was the purpose of this chapter. Deforestation and forest degradation analysis approach was utilized. One state and two forest communities from each of the rainforest, savannah, and mangrove agroecological zones were purposively focused in this chapter based on forest distribution and cover. Focus group discussions involving 252 male and female farmers using 30 years as reference were used to garner relevant information. Climate variation caused a slight modification in cropping schedules of farmers due to prolonged dry season, mainly in the savannah region. Farmers engaged in mixed farming and also cultivate more hardy crops like cassava in response to climate uncertainties. Especially in the mangrove and savannah, ecosystem components such as agriculture and population showed increasing trends over the years as forest cover reduces. Downward trend in charcoal production was limited to mangrove and rainforest zones as fishing and hunting becomes vulnerable livelihoods across the zones. The degree and progression of climate change effects on the ecosystem in Nigeria agroecological zones is largely comparable and have both desirable and adverse livelihood outcomes. Affordable insurance policy, credit, agri-inputs, favorable forest regulatory framework, and youth empowerment supports would enhance sustainable adjustment to climate change.

## Keywords

Forest communities · Cropping calendar · Agroecology · Climate change · Vulnerability · Rural livelihoods · Nigeria

## Introduction

Nigeria is seriously threatened by climate change with a significant proportion of its terrestrial ecosystem on dry land mass which is frequently affected by desertification, sheet erosion, and droughts. The coastal and mangrove agroecological zones in the south are also prone to incessant flooding because of their proximity to the Atlantic Ocean, riverine nature of the setting, the very low altitude, and all-year-

round and high volume of rainfall. In recent times, variations in climatic conditions have resulted in undesirable effects on food production and nutritional security. Unfortunately, the country has very weak adaptive strategies and capacity to mitigate the effects of a changing climate. Presently, the impacts of rising temperatures and rainfall variability on farming are being felt across major agroecological zones in Nigeria (Ayanlade et al. 2018).

Agricultural systems are dependent on ecosystem services such as nutrient cycling, pollination, soil fertility, hydrological balances, and biological pest control which ensure a balance in the ecosystem (Power 2010). However, agricultural intensification in the last century has distorted the ecosystem equilibrium and led to loss of ecological integrity, land degradation, and loss of environmental services provided by the ecosystems. These conditions are further worsened due to increasing effects of climate instability (Pretty et al. 2011). For instance, environmental problems such as groundwater depletion, variability in the onset and amounts of rainfall, increase in concentration of greenhouse gases, soil degradation, depletion of pollinators' habitat, which all have negative consequences on sustainable agriculture, are climate change-induced.

Forest communities, which are highly vulnerable to these adverse effects, are occupied by low-income earners who depend on the ecosystem for their income, food, nutritional security, and livelihoods. Hence, these rural populations will be seriously affected by climate change, with little or no resources to adapt or mitigate its effects. It has been reported that the livelihoods of these communities are made vulnerable by land use variation such as continuous grazing and monoculture plantation. For example, in coastal and mangrove regions, there is a shortage of food resources obtained from streams coupled and agricultural instability due to increased flooding (Ward et al. 2016). Similarly, savannah and rainforest agroecosystems are recording a decline in agricultural production outputs (Ayanlade et al. 2018).

Natural resource utilization forms the base of most livelihoods in developing countries including Nigeria. However, forest resources are gradually being depleted due to the pressures of degradation and deforestation, poverty, urbanization, and poor management (Azeez et al. 2010; Saka et al. 2013). In Nigeria and most parts of Africa, shifting cultivation among small-holder farmers results in large-scale habitat destruction (Cooper et al. 2008). For instance, over 75% of the Nigerian population still lives in rural areas with vast areas of forest vegetation and depend on extensive rain-fed farming as well as short fallows for their sustenance. However, this dependence is limited by loss of forest biodiversity, climate change, and exposure of fragile soils (Azeez et al. 2010).

Frequent changes in climate parameters affect the livelihoods of rural populations and poses challenges to food security, survival, and economic development (Tompkins and Adger 2004). For instance, savannah and tropical forest zones have experienced a dramatic decrease in annual rainfall and an increase in the length of dry season and rainfall variability (Malhi and Wright 2004; Veenendaal and Swaine 1998). It is therefore pertinent to investigate the forest-dependent communities' responses to the hazards posed by climate uncertainties on their environment

and livelihoods (Lindner and Pretzsch 2013), as this will have important implications for sustainable development in the near future.

The capability of farming communities and agricultural stakeholders to manage the challenges and prospects of present climatic patterns must primarily be improved in order to enhance their adaptive capacity and reduce their exposure to the undesired effects of changing climatic conditions (Cooper et al. 2008; Tompkins and Adger 2004). The challenges are complex and call for integrative learning-oriented approaches that emerge from the bottom-up that will enable successful mitigation and adaptation. These approaches offer pathways for vulnerable communities to engage in developing response policies and ensure that there is room for change in those policies (Lindner and Pretzsch 2013).

Adaptive management is a cyclic, multiple stakeholder learning-oriented approach to the management of complex environmental problems such as climate change. The introduction of such approaches would encourage multi-stakeholder participation and the integration of all sectors in decision-making, policy formulation, and implementation (Stringer et al. 2006). Unfortunately, most policy implementers adopt a top-bottom approach where local problems are treated in isolation, and this method has proven to be ineffective in yielding or sustaining solutions. Therefore, the need for all-encompassing approaches to manage the demand for arable lands, forest resources, and the problems arising from resource exploitation and climate change (Lindner and Pretzsch 2013; Tompkins and Adger 2004). A step towards achieving this is to understand that the poor and vulnerable themselves are key actors in identifying important areas of their own livelihoods and solutions to their challenges.

For instance, rural communities have in times past developed indigenous technologies which have assisted in mitigating the risks associated with climate variability. These technologies are represented in local customs, traditions, and heritages, constituting a testimony of how societies have thrived well in various environments (Azeez et al. 2010; Vidaurre de la Riva et al. 2013). Therefore, research needs to integrate climate change impacts with sustainable agriculture in a stressed ecosystem. Such information will bridge the knowledge gap and assist planning for adapting and mitigating climate change. Therefore, this chapter explains how agriculture, climate change, and the ecosystems interrelate among themselves in the main agroecological zones of Nigeria. Specifically, this chapter discussed the effects of the changing climate on farming calendar and local adaptation measures employed, the trend in primary drivers of social vulnerability to climate variability, the drivers of vulnerability to climate variation as perceived by farmers, health and environmental effects of climate instability on forest communities in Nigeria, and forest inhabitants needs in services and or facilities for an effective adjustment to climate change.

## **Forest Livelihoods and the Challenge of Changing Climate**

Forests are mainly situated in rural areas and/or frequently isolated areas (Aruwajoye and Ajibefun 2013). Apparently, such areas are in close harmony with nature with

little development in terms of infrastructure (roads, potable water supply, markets, health facilities, and schools), government services, and jobs. Thus, it is not surprising that communities living in the fringe of these forests have limited livelihood opportunities and options (Wunder 2005). As a corollary to this, Bassey and Obong (2008) and Nayak et al. (2012) assert that communities around forest fringe are low-income earners who sought to build their economic capacity by engaging in the livelihood options provided by the forest.

In Nigeria, more than 90% of the rural populace depend on forests for their livelihood (Ayuk et al. 2011; Fadaïro et al. 2017). These livelihood activities offered by forests include hunting of animals, forest-based farming, timber logging, gathering of building materials, collection of fuel wood for cooking or charcoal production, materials for local craft, fodder (grasses and leaves for livestock and grazing of livestock), medicinal plants, and non-timber forest products which include honey, leaves, and fruits. Suffice it to say that these forest products derived from the various livelihood activities are not solely for household consumption but also for commercial purposes.

Studies have documented the benefits accruing from forest resources in the livelihood activities of those inhabiting the fringes of forests as substantial (Levang et al. 2005; Sunderlin et al. 2005). These benefits according to Warner (2000) are increased income, improved food security, reduced vulnerability by providing safety nets, and increased well-being. Furthermore, some of these livelihood activities have social, religious, and cultural dimensions. For instance, hunting may serve as a cultural event for initiation into manhood while fishing maybe a social or cultural event. In addition to this, Shackleton (2004) opine that forests provide sites for spiritual healing and religious practices. Hence, it is not uncommon to find sacred places, herbalists, and native doctors in forest communities.

Agriculture as an important livelihood activity in most forest communities is affected by climate change in several ways, namely, changes in rainfall, standard temperatures, and climate extremes (heat waves). Climate change influences planting and cropping conditions which in turn affects the supply of food. It necessitates changes in farming methods, increases soil pressure, reduces water supply to the root system, and increases farmers reliance on agrochemicals for farming. In addition, crops stressed as a result of climate changes become more susceptible to damage from diseases and pests. Animal husbandry industry is also indirectly affected following climate-induced changes in the availability of grains, pasture, and forages and its accustomed price increase. Animals health are usually affected negatively by extreme heat (Enete 2014). Furthermore, peasant and small-holder farmers who produce the bulk of food consumed in most developing countries are usually vulnerable to climate uncertainties due to their small size of farms, poor technology, and little working capital (Morton 2007). In addition, the seasonal calendar which provides information on planting, sowing, and harvestings periods of locally adopted crops in specific agroecological zones (Fadaïro et al. 2019) is distorted by climate variability, predisposing farmers to risks arising from weather uncertainties.

## **Agriculture, Climate Change, and Food Security**

The occurrence of climate change is interlinked with the performance of agriculture and attainment of food security. Agricultural production in most parts of Africa including Nigeria has been seriously affected by environmental degradation caused by climate change, making a case for serious intervention (Osuafor and Nnorom 2014). The current global climatic condition has both natural and man-made causes. The reliance on rain-fed agriculture by most African countries both as a source of income and consumption has resulted in their high vulnerability to climate change. Some of the devastating effects includes: erosion, flooding, drought, pests and diseases, desertification, gas emissions, fluctuation in rainfall patterns, and a host of others. These factors in turn impact on agriculture and consequently threaten food security. As a result, food security is at risk with a daily world population increase. In order to forestall the danger ahead, the United Nations has clearly set the targets of attaining food surplus, food security, and improved nutrition, and advancing sustainable agriculture as number two among its 17 Sustainable Development Goals (SDGs) for the year 2030.

According to Food and Agriculture Organization (2002) as cited by Coates (2013), food security exists when all individuals, at every time, have socioeconomic and physical access to adequate, nutritious, and safe food that meets their dietary requirements and food preferences for a healthy and productive life. Therefore, food security goes beyond having adequate supply of food but also include issues relating to the food safety and hygiene. For instance, use of chemicals such as fertilizer in planting or produce preservation as a response to climate fluctuation predisposes the population to poor health. This assertion is in line with Kinsey (2005) who opined that a nation is not regarded as food-secure just because food is available in the right quantity needed by its populace, but also when the food consumption does not predispose the people to any health hazard. In order to reduce the impacts of climate change on agriculture, various coping strategies have been put in place. Osuafor and Nnorom (2014) highlighted the strategies as including controlling greenhouse gases emission; preventing deforestation; planting climate-smart, disease-tolerant, and high yield crops; and adjustment of planting calendars by farmers.

### **Climate Change and Drivers of Social Vulnerability in Nigeria**

In recent times, the variation in climate such as rise in temperature, increase in rainfall causing flood, delayed and inconsistent rainfall causing drought, strong wind, and landslides have threatened both the natural systems and the human society, specifically causing internal displacement of persons, destruction of lives, properties, and livelihood, food insecurity, disease outbreak, violence arising from struggle over resources, and increased suffering and penury. Yet, the impact caused by these climate extremes is not uniformly distributed among and within groups of people in the same country, state, and/or community (Petkova et al. 2015). Thus, it is unlikely for the impact of climate extremes to be felt in the same way. Some groups

or individual are likely to be more vulnerable than others. This underscores the need for researches to continually explore comparative analysis of climate change impacts across environmental, social, economic, and political factors in order to engender sustainable solutions.

In the views of Petkova et al. (2015), climate change effects will vary among age groups, sex, socioeconomic status, health condition, geographical location, and nature of livelihoods of the people. A measure of the extent of exposure of groups or individuals to stress as a result of the impacts of climate change extremes is known as social vulnerability. In this chapter, livelihood of the forest-edge communities in Nigeria is singled out among others for discussing the effects of vulnerability to climate change. Hence, stress in this perspective refers to the interference of the livelihood activities of groups or individuals in the face of climate extremes.

Evidence abounds that the people who are likely to be more susceptible to the adverse effects of climate extremes are people in the rural areas. Rural Nigeria is mainly agrarian with many of them living below the poverty line. Research reveals that rural communities are inexplicably vulnerable to climate extremes because their livelihoods are dependent on climate-sensitive activities (agriculture, forestry, fishing, recreation) in their rural environment (Fisher et al. 2013). Therefore, the effect of climate extremes poses a huge threat especially to the agrarian rural people many of whom already live below the poverty line.

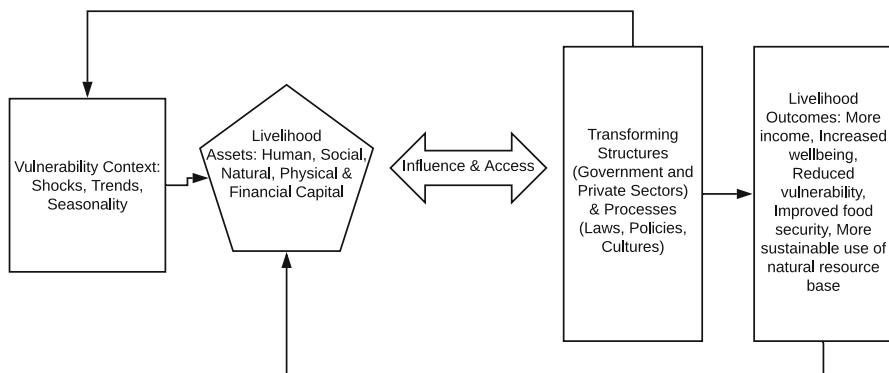
---

## Theoretical Framework

The Sustainable Livelihood Framework, as presented below, was considered relevant for underpinning the assumptions and approach utilized in this chapter.

### Sustainable Livelihood Framework

Sustainable livelihood (SL) framework presents a tool for development workers to understand, analyze, and explain the real factors that affecting poor people's livelihood (Petersen and Pedersen 2010). According to Carloni and Crowley (2005), a livelihood comprises the assets (including both social and material endowments), capabilities, and activities necessary to earn a living. Ability to manage and recover from shocks and stresses, retain or enhance its assets and capabilities, while not depleting the natural resource base is what makes a livelihood sustainable. SL framework addresses the creation of guaranteed livelihoods for the poor by development workers. The basic principle of SL is that development work ought to focus on the people, with considerations of, what matters for the poor, cultural diversity, and its effects on livelihood processes. Secondly, poor people themselves are major actors in bringing about the change they desire. This is because they have a better knowledge of issues affecting them much more than any external person (Petersen and Pedersen 2010). The foregoing reechoes the central argument in this chapter that adequate understanding of the perspectives of the local people whose livelihoods are



**Fig. 1** Sustainable Livelihood Framework. (Source: DFID (2000), cited in Petersen and Pedersen (2010))

intertwined with and affected by climate variability is important for a more sustainable adaptation and mitigation measures for climate change. Hence, primary information used for discussion in this chapter were derived from engagement with those who are most affected in order to acquire their perspectives of their problems and what things to change to improve their condition. The key components of the SL framework are indicated in Fig. 1, and they include vulnerability context, livelihood assets, structure and process for transformation, livelihood strategies, and livelihood outcome.

**Vulnerability context:** This refers to people's external environment. It includes occurrences for which people have restricted or no control. Examples of such occurrences are critical trends of economic inflation, natural disasters, shocks, and seasonality, among others. The issue of vulnerability thus emerges when individuals are exposed to harmful threats they are not well equipped to confront (Petersen and Pedersen 2010).

**Livelihood assets:** Since the framework by nature focuses on the people, it thus seeks to have a better consideration of the people's power (capitals or assets). Since the approach relies on the belief that achieving livelihood outcomes requires a combination of assets, understanding how the conversion of the people's power to favorable livelihood outcomes becomes paramount. For this reason, the framework identifies five forms of capitals which support livelihoods. These are social, human, natural, financial, and physical capitals (Petersen and Pedersen 2010).

**Structure and process for transformation:** This refers to the establishments and regulations found from the household to the international levels that defines the livelihoods of the poor. These establishments and regulations stimulate how people access the various types of assets. Ownership rights and laws to secure individual rights are examples of processes, whereas structures are things like existence of ministries, banks with credit facilities for support groups and farmers (Petersen and Pedersen 2010).



**Livelihood strategies:** This refers to the way in which people organize towards achieving their anticipated livelihood and access to diverse types of resources determine the approaches to be employed. Furthermore, societal opportunities or constraints can be dictated by its structures and processes.

Finally, **livelihood outcome** refers to the resultant effect of livelihood strategies assumed by the people. These effects could be better income, enhanced wellness, decreased susceptibility, and food security, among others (Petersen and Pedersen 2010).

---

## Chapter Approach

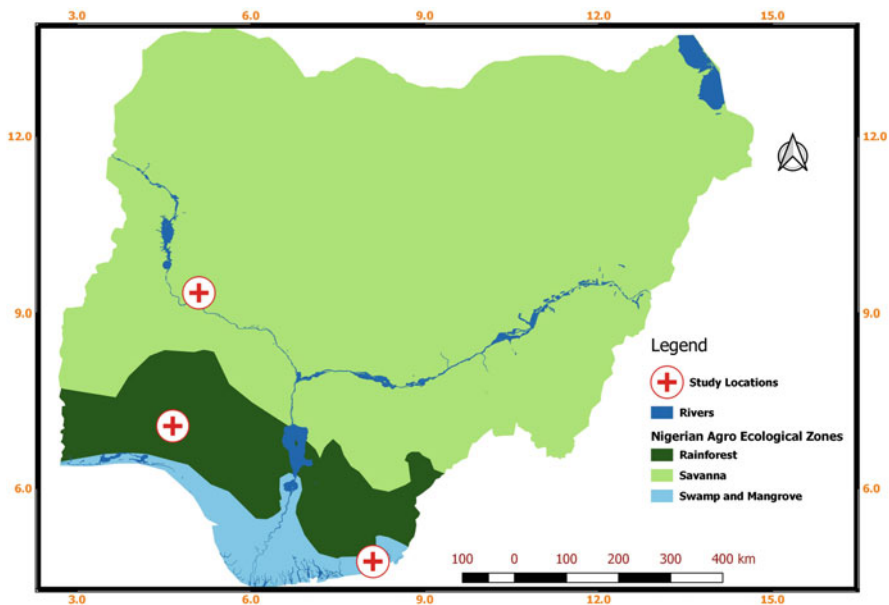
This chapter utilized synthesis of literature and collection of primary data to reach its conclusions. The field activities for primary information gathering were carried out in Nigeria. Nigeria's ecological environment consists of seven agroecological zones such as saltwater swamp, freshwater swamp, Sudan savannah, guinea savannah, Sahel savannah, tropical rainforest, and the montane zones. However, discussions in this chapter are mainly focused on its three broadly classified agroecological zones namely savannah, mangrove/swamp, and rainforest. Each of these agroecological zones has their own peculiarities and supports a wide range of plant and animal species. Nevertheless, the tropical rainforest has been adjudged the richest. All adult residents in forest communities who are engaged in farming and or other forest-based livelihood activities were engaged in discussions. Adults who were 45 years and above at the time of the field work were specifically targeted due to the 30 years reference period used in this chapter. A two-stage sampling procedure was used. First, from each of the three major agroecological zones, one state was purposively sampled based on distribution and extent of forest cover. Second, two forest communities in each sampled state were selected purposively based on intensification of climate variability in the past 15 years. Thus, six forest communities namely Iyamitet, Ikom Agoi (Cross River State), Wawa-Gbere, Emi-Hakimi Mokwa (Niger State), Osoku, and Fowowa (Ogun State) were sampled for primary information gathering (Fig. 2). In each of the sampled locations, a short survey was carried out to generate a pool of potential participants for focus group discussions as follows:

Would you be willing to participate in a focus group discussion regarding climate change, rural livelihoods and other related issues? The discussion would take about 2-3 hours on ..... (date) and you would be incentivised for participation. The discussion will be audiotaped for the purposes of review by the researchers.

Yes [ ] No [ ]. Name. .... Phone no. ....

Age.....

Given the size of potential participants generated, four focus group discussions comprising 10–12 members per group were held in each forest community. Thus, qualitative data were collected from 24 focus group discussions held with 252 male and female farmers in selected sites. Deforestation and Forest Degradation Analysis adapted



**Fig. 2** Map showing the focus group discussion locations within the agroecological zones of Nigeria

from Tiani et al. (2015) was used in this chapter. Using a discussion guide and 30 years as reference, primary information was sought on effects of climate change on farming calendar, trends in primary drivers of social vulnerability to climate change, causes and consequences of environmental degradation in forest communities, and communities needs in services and/or facilities for an effective adaptation.

A visual representation showing seasonal activities among community members on a flip chart was used to facilitate conversation on how climate change affects farming calendar. Discussants indicated their cropping pattern in a calendar year, the associated activities, and why the activities are conducted in order to provide information on farmers' local climate change adaptation measures. Also, participants during the discussions used pebbles (stones) to proportionately represent areas covered by each ecosystem components (population, agriculture, forest cover, hunting, and charcoal production) as perceived over the past 30-year period (Figs. 3, 4, 5, and 6). The outcome of this exercise was represented in a single table to indicate the trend as perceived by the discussants. Influence of climate change on local livelihood activities were captured by asking participants to award scores to represent magnitude and impact of each climate parameter on available livelihood activities. Problem tree analysis and paired needs ranking participatory tools were used to investigate health and environmental impacts of unstable climate on forest communities and communities needs in services and or facilities for an effective adaptation to climate change, respectively.

During the discussions, audiotape recording, flip chart, and handwritten notes were taken by researchers and were later transcribed. Primary information collected

**Fig. 3** Male participants during focus group discussion at Mokwa, Niger State on March 9, 2018



were coded and analyzed based on thematic patterns in the participants responses to issues raised in the focus group discussions. In doing this, particular attention was paid to important quotes from some of the respondents. Some of these quotes are used as evidences to support discussions in this chapter.

Limitations however exist in the approach used in this chapter due to language barrier experienced in some of the field locations as we observed that some respondents could not communicate well in the English language. Therefore, the researchers relied on translators to interpret the questions to the respondents and participants' responses back to the researchers. Some content and meaning may have been lost in this process. Also, due to the problems of insurgency, farmer-herdsmen conflict, and other security issues, most states within the savanna agroecological zone were deliberately excluded from the focus group discussions.

---

### **Effects of Climate Variability on Cropping Calendar in Mangrove, Rainforest, and Savannah Agroecological Zones of Nigeria**

Farm households' ability to grow enough food to feed themselves and their animals is determined to a large extent by the weather since agricultural production depends on climate variables, such as temperature, precipitation, and light. Therefore,



**Fig. 4** Male participants during focus group discussions at Iyमितet, Cross River on 14 February, 2018



**Fig. 5** Female participants at FGD at Mokwa on March 9, 2018

**Fig. 6** Female participants at FGD on April 11, 2018 at Osoku



shifts in temperature and precipitation are important parameters for farming communities in the timely operations of farm operations. Table 1 shows the activities done in relation to the major crops produced by each of the ecological zones. Yam, cocoa, and maize were focal crops in the mangrove, rainforest, and savannah zones, respectively. Within the mangrove ecological zone, the major activity between January and May was land preparation, with dry and wet seasons being observed in March 30 years ago. Currently, there is a little shift, as dry and wet seasons are now being observed in April. It was clear that there is a relatively longer dry season now compared to what it was 30 years ago as wet season was fully experienced from April to September, lasting a period of 6 months. In the recent times, however, the wet season now occur in May to August, lasting only 4 months. This trend is similar to what is observed in the rainforest and savannah zones with extended dry season compared with the referenced 30 years ago. This shows a drop in the duration of rainfall across the three agroecological zones. This change in climatic trend is in line with the position of Appiah et al. (2018) that there is a decrease in the intensity of rain in most forest reserves communities of most sub-Saharan African countries where there is still heavy reliance on agriculture as primary means of livelihood. This change has implications for agriculture in Nigeria which is known to be mainly rain-fed.

Further, two of the participants at focus group discussions gave explicit distinctions of the season and farming activities between 30 years ago and now as thus:

**Table 1** Seasonal and cropping calendar for major crops in mangrove, rainforest, and savanna ecological zones of Nigeria

	Months of the year (January-December, respectively)											
	J	F	M	A	M	J	J	A	S	O	N	D
<b>Mangrove</b>												
Season 30 years ago	D	D	D/W	W	W	W	W	W	W	D/W	D	D
Season currently	D	D	D	D/W	W	W	W	W	D/W	D	D	D
Activities currently	<ul style="list-style-type: none"> <li>● Land preparation</li> <li>● Planting</li> <li>● Weeding</li> <li>● Staking</li> <li>● Harvesting/storage</li> </ul>											
<b>Rainforest</b>												
Season 30 years ago	D	D	D/W	W	W	W	W	W	W	W	D/W	D
Season currently	D	D	D	D/W	W	W	W	W	W	DW	DW	D
Activities currently	<ul style="list-style-type: none"> <li>● Land preparation</li> <li>● Cocoa nursery</li> <li>● Planting</li> <li>● Weeding</li> <li>● Spraying</li> <li>● Harvesting/storage</li> </ul>											
<b>Savanna</b>												
Season 30 years ago	D	D	D/W	W	W	W	W	W	W	W	W/D	D
Season currently	D	D	D	D	W	W	W	W	W	W/D	D	D
Activities currently	<ul style="list-style-type: none"> <li>● Land preparation</li> <li>● Planting</li> <li>● Weeding</li> <li>● Harvesting/storage</li> </ul>											

*D =Dry, W = Wet, D/W =Dry & Wet*

Thirty years ago, we experienced little rainfall in the month of March and then the rains become fully established in April and then fade away in September. Presently, we experience little rainfall in the month of February which become fully established in April and then fades out in October.

Land clearing of farmland in our area has shifted from January/February to March. This happens because onset of rain has shifted to April, currently any rain we see in February/ March is tagged accidental rain.

Another discussant also said:

‘Compared to thirty years ago, there is reduced intensity and duration of rainfall’ (A 50-year-old man, Muslim, farmer, savannah zone).

Access to food through both production and exchange will continue to depend not only on the productivity and profitability of agriculture, but also on how well the political climate enables people to respond creatively to their environment and prospects. As a means of adapting to the extended dry spell, farmers have adopted the cultivation more hardy crops such as cassava to reduce economic losses

associated with climate change. Diversification into trading and processing of agricultural produce also take place during the off seasons to bridge income gap that is now experienced. This corroborates the assertion of Appiah et al. (2018) which argues that farmers in forest communities are often engaged in other economic activities to supplement their agriculture-based incomes. One of the discussants said thus:

Presently, when there is no planting activity, we engage in other businesses like buying and selling so as not to be idle and to earn money.

### **Perceived Trend in Agriculture, Forest Area, and Population as Primary Drivers of Social Vulnerability**

The relationship between climate change and ecosystem is intertwined. Climate change can affect the distribution and behavior of some ecosystem components. Conversely, the intensification of some ecosystem components such as forest cover also have implications for carbon sequestration capacity, and hence extent of climate change impact on the environment. In this chapter, element of the ecosystem such as agriculture, forest cover, population, and alternative income-generating activities in the sampled sites such as fishing, hunting, and charcoal production were focused for understanding the interrelationship among these elements and climate change. Across the three agroecological zones of rainforest, mangrove, and savanna, more people are presently involved in agricultural activities compared with 30 years ago. This, according to discussants, is due to lack of employment for graduates and irregularities in payment of salaries/wages to government workers. Therefore, the need for alternative sources of income or employment (for the unemployed) has caused the recent surge in the farming population in the areas. A 48-year-old woman farmer in one of the rainforest communities explained thus:

Very few people were involved in agriculture thirty years ago in our community, then, youth only engaged in land clearing, planting and weeding of their parents' farms. However, as our population increases many people got involved in agriculture and young people now cultivate their own farmlands.

Population as a component of the ecosystem also witnessed increasing trend in the last 30 years in all the agroecological zones. Population is a key factor that differentiate Africa from other regions of the world. African population is projected to grow rapidly throughout the twenty-first century and this growth will have direct effect on the demands for agricultural commodities. Discussants explained that increase in population is caused mainly by two factors. First, migration of people into various communities within the area for livelihood, especially in agriculture. Rural areas are known to be rich in an important factor of production which is land. Second factor was increase in child-bearing and survival of children due to improved health awareness. However, while there was

increase in population and intensity of agriculture across the agroecological zones, decrease in forest spread and abundance of non-timber forest products such as snails and mushrooms was observed across the zones in the last 30 years. This is caused by deforestation and bush burning, occasioned by increase in population. Increasing population exerts more pressure on resources leading to upsurge in the rate of felling of trees for cooking and charcoal production. Increasing involvement of people in agriculture and declining soil nutrient also led to agricultural “extensification” and the consequent expansion of land for agricultural activities. The implication is that more forest cover is removed in order to increase size of land cultivated for farming. A 52-year-old man in one of the savannah communities remarked during the focus group discussions as follows:

The forest cover has drastically reduced against how it was. In those days we usually have 10-2 stumps of tree together, but due to deforestation by saw millers, increase in land acquisition for farming activities and construction of houses, almost all the trees are gone.

Further, hunting and fishing activities have assumed a downward trend in the savanna, mangrove, and rainforest zones in the last 30 years. This can be attributed to a decline in their distribution in their natural habitat and hence, reduced motivation on the part of the hunters and fishermen to continue in the business due to low rewards. In addition, reduced trend in fishing activities in the locations is plausibly due to water pollution, overfishing, and reduction in water volume caused by prolonged drought and a decline in intensity and duration of rainfall. Idowu et al. (2011) confirmed a decline in Catch Per Unit Effort (CPUE) in coastal areas of Nigeria due to pressure of climate change. However, charcoal production is among the gradually becoming prominent livelihood activities in savannah and mangrove zones. This is perhaps as a replacement for fishing and hunting livelihood activities that are already becoming faded in the areas. Charcoal production serves as an alternative income source for farmers in rural communities while ignoring its long-term implications for a sustainable environment. This is consistent with Mwampamba (2007) who had projected that by 2028, public forest resources would be depleted in some parts of Africa and there would be a total collapse of charcoal chain if no measures are put in place to stop the trend. Mwampamba’s position suggests that there is an arbitrary involvement in charcoal production and that the rate of growth in the sector is largely unsustainable. Massive charcoal production in the areas have implications for availability of Non Timber Forest Products (NTFPs) in the area. During the focus group discussion, one of the discussants explained (Table 2):

Duration of time used for collecting products in the forest has reduced because of scarcity of these products in the forest. Harvest from NTFPs was much thirty years ago (A 45-year-old woman, Christian, farmer, rainforest zone)



**Table 2** Trend in ecosystem components as primary drivers of social vulnerability to climate change

Agroecological zones	Ecosystem components	Index of intensification in last 30 years (%)			
		1987	1997	2007	2017
<b><i>Rainforest</i></b>	Agriculture	18.6	21.0	24.6	36.0
	Population	25.0	20.6	21.6	33.6
	Forest cover	44.6	24.6	19.6	11.6
	Fishing	58.0	22.0	14.0	6.0
	Charcoal production	100	0	0	0
<b><i>Mangrove</i></b>	Agriculture	18.5	21.0	24.5	36.0
	Population	25.0	20.0	21.5	33.5
	Forest cover	44.5	24.5	19.5	11.5
	Hunting	56.0	24.0	14.0	6.0
	Charcoal production	92.0	0	0	8.0
<b><i>Savanna</i></b>	Agriculture	21.0	15.5	20.5	43.0
	Population	15.0	20.0	23.0	42.0
	Forest cover	46.0	24.0	18.0	12.0
	Fishing	38.0	20.0	20.0	22.0
	Charcoal	4.0	9.0	19.0	68.0

## Perceived Effects of Drivers of Climate Change on Household Livelihood

Weather patterns are becoming unpredictable due to increasing variability in climate parameters. Rising temperature and increased frequency of extremely dry and wet years are expected to slow progress in crop productivity, livestock system, and improved food security. This section explains the effects of drought, flood, pest and diseases, increase in temperature, and strong wind as observable drivers of vulnerability to climate change in the Nigeria agroecological zones. The effect of each was captured in both direction (negative or positive) and magnitude (which measures the extent of such effects) on subsistent crop, cash crop, charcoal production, and animal production. In the agroecological zones, the negative effects of drought were most felt on subsistence crops. Cash crops such as cocoa were not spared as the effect was high, especially on the field. An opinion leader among the farmers in Iyamitet community (mangrove zone) explained thus:

In recent times, there is incessant invasion of pests and diseases on our crops which we cannot effectively control. Most times, it takes a lot of time before we understand the nature and causes of such infestation and able to adjust to it. The result is a serious reduction in the quality of our crops and huge losses for us. Ugly experience from the last year harvest has even discouraged some few cocoa farmers from business.

Discussions further revealed that charcoal production was the most resistant or the least affected by drought in the ecological regions. The reverse was the case with

respect to flooding, as charcoal production was reportedly highly affected in terms of quality of charcoal, quantity of wood (log), and duration of activities of charcoal production. The level of vulnerability was also high for subsistent crops, cash crops, and availability of NTFPs. Discussants during the focus group sessions justified their position that flood has a high negative effect on charcoal production explaining that when flood occurs, it washes away the charcoal heaps and woods, thereby terminating the charcoal production process. The implication is that while flooding is not an everyday occurrence, the few times it occurs, it has considerable negative effect on the quantity, quality, and hence profitability of charcoal production among producers.

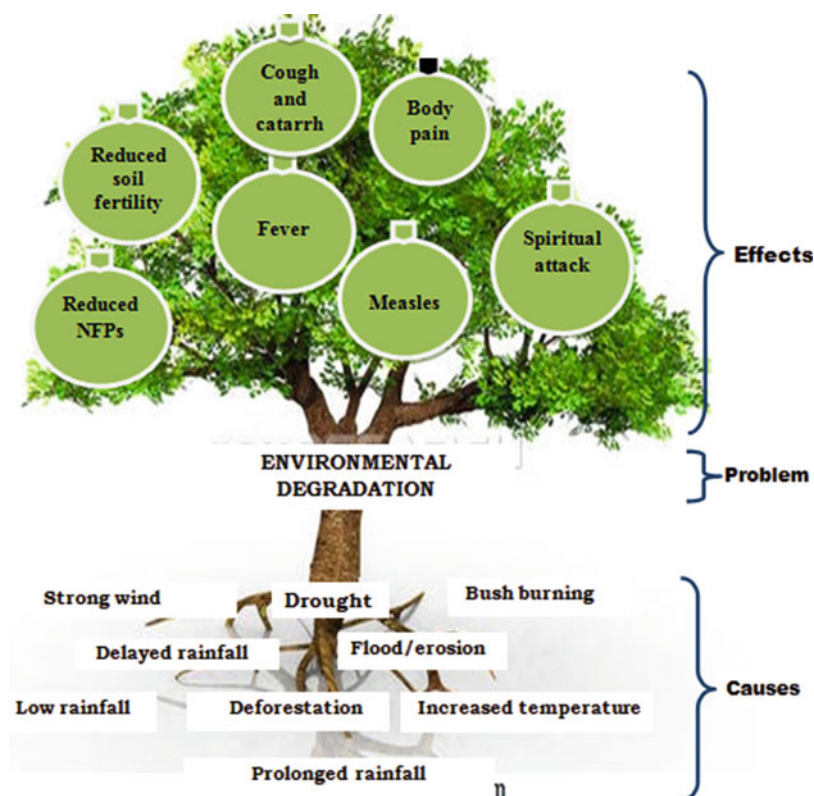
Furthermore, livestock production was the least threatened livelihood by increased temperature, with little or no observable implications for livestock/milk production. However, almost all the livelihood activities were threatened by increased temperature with negative implication for future and present income generation among the people. The effects of pests and diseases, which were also directly associated with climate change as reported earlier, is also evident on subsistent crop, NTFPs, and cocoa production. This rating agrees with the position of majority during discussions as they were unanimous that pests and diseases had grown in both frequency of occurrence and severity of effects in the past few years with observable negative effects on crops and other means of income generation. On the other hand, the effects were less felt on charcoal and livestock production.

The last driver considered was strong wind. This chapter reveals that strong wind had the least effect on respondent's various livelihood activities, with the most visible effects on NTFPs and the least on livestock production. The effect was rated moderate on charcoal production. This rating was backed by some explanations during discussion as follows:

Strong wind often has negative effect on quantity of charcoal produced. This is often due to strong wind and availability of opening on the charcoal heap. This causes air to enter the charcoal heaps. This occurrence often reduces production efficiency, leading to high ash to charcoal ratio, thereby reducing quantity and profitability of our charcoal production enterprise.

## **Causes and Consequences of Environmental Degradation in the Nigeria Agroecological Zones**

The problem tree analysis in Fig. 7 illustrates the composite results of the effects of environmental degradation in the three ecological zones. It gives the causes and effects of the common problem identified as environmental degradation. The causes of environmental degradation identified in this section are consistent with earlier discussions and include drought, deforestation, strong wind, delayed rainfall, bush burning, use of agrochemicals, and air pollution. This corroborates the report of Somorin (2010) that impact of climate change could be felt by increased temperature, deforestation, and drought. Discussants also reported that the effects of



**Fig. 7** Problem tree analysis of causes and consequences of environmental degradation in Nigeria

environmental degradation produced both adverse health and environmental consequences such as mental disorder, measles, meningitis, water scarcity, erosion, cough/catarrh, body pain, reduced NTFPs activities, erosion, poverty, low income and poor harvest, soil infertility, increased incidence of pest and diseases and fever.

Specifically, in savannah zone, respondents experienced strong wind which carries particles of dust causing cough and catarrh. Idowu et al. (2011) established that respiratory diseases and infections like cough and catarrh are prominent in harsh climate due to presence of pollutants and dust. Also, increased temperature in the area causes meningitis and measles which is very common in children of less than 5 years. A 37-year-old woman from savannah zone and 30-year-old lady from mangrove zone are quoted, respectively, as follows while commenting on the consequences of some of climate change parameters on their health and livelihoods:

During hot weather, as we now frequently experience here, there is usually the prevalence of meningitis, measles and chicken pox especially among our children. Also, wind is accompanied with dust, and this brings about occurrence of cough and catarrh is common. Increased temperature also affects our animals and crops as pests and diseases grow more

when the weather is hot which slow down crop production (A 37-year-old woman, Muslim, farmer, savannah zone).

The impact of wind is low and it could be beneficial when drying crops after harvesting them. But when it is too strong, it could destroy the crops' (A 30-year-old woman, Christian, processor, mangrove zone)

An interesting link between deforestation and pervasiveness of mental disorder among the people was alluded to in Wawa community (savannah zone) where the participants argued that deforestation releases certain spirits which are believed reside in trees to inflict young ladies with insanity. One of the male discussants said the following:

Due to deforestation, spirits that abode in the trees are made homeless and therefore come to town and enter into our young ladies making them go insane. We are able to establish this because during deliverance session for some of the victims, the spirits confessed that their natural habitats have been disrupted and that's the reason for the attacks.

### **Farming Communities' Needs for an Enduring Adaptation to Climate Change in Nigeria**

Farming communities' adaptation is key in translating climatic challenges and agricultural responses into changes in production, prices, food supply, and welfare. The potential for positive change for farming communities will increase if farmers are helped to adapt to climate variability. Table 3 therefore show the priority ranking of what communities in the agroecological areas adjudged as their needs to effectively adjust to climate changes impact. Across the ecological zones, respondents highlighted some needs that were important due to various problems and setbacks they encountered arising from climate change. Availability of credit facilities ranked first, suggesting lack of sufficient capital for various livelihood activities and effective climate change adaptation. Building of health center

**Table 3** Needs matrix as identified by communities in forest-edge communities in Nigeria

Needs	Ranks
Credit facilities	1
Health center	2
Farm inputs – improved seed variety, fertilizer, herbicides	3
Good road network	4
Pipe borne water	5
Power supply	6
Irrigation	7
Communication network	8

ranked second as most of the communities' lacked access to well-equipped health centers that can provide health care services. Farmers also require farm inputs in the form of herbicides, improved seed varieties, and fertilizer as the third ranked need. Perhaps, the need to easily connect outside communities for timely marketing of agricultural produce necessitated farmer's choice of good access-linking road. Discussions revealed that farmers find it difficult to sell their produce to right buyers due to poor state of farm-to-market road. Instead, commodities were often sold to middle men at farm gate prices and hence, low profitability for the farmers. Other infrastructure such as pipe borne water, power supply, communication network was also mentioned as some of their pressing needs across communities in the agroecological zones. The huge infrastructural deficit in the sampled locations is indicative of the state of physical development in most of the forest-edge communities in Nigeria. This corroborates the earlier assertion by one of the discussants:

'We strongly desire credit facilities and good road network to enable us perform better in our farming activities and also for outsiders to come into our community and trade with us' (A 52-years-old man, Christian, farmer, rainforest zone)

---

## Conclusion and Recommendation

This chapter concludes that the scale and direction of climate change impact on agriculture as the primary rural livelihood and other ecosystem components in Nigeria's agroecological zones is largely comparable and have both positive and negative consequences on rural sustenance. While climate change impact combined with some other economic factors such as unemployment have encouraged urban-rural migration, agricultural intensification, and livelihood diversification on the one hand, it has increased vulnerability tendencies of rural households in forest-edge communities in all the agroecological zones of Nigeria on the other hand. Among several others, increased forest encroachment, lack of a well-coordinated policy framework which allows for alternative livelihood without accompanying forest regulatory framework were major vulnerability exacerbating factors for the rural poor. Although the rural populace need help for better adjustment to climate change, they also do have demonstrated ability to respond to changes occasioned by climate variability and are exploring these abilities to the best of their knowledge. Support in the form of affordable insurance policy, credit, agri-inputs, favorable forest regulatory framework, and youth empowerment would enhance sustainable adjustment to climate change among the rural people.

**Acknowledgments** This work was supported by the African Development Bank and Japan Trust Fund under the Education for Sustainable Development in Africa (ESDA) project on knowledge creation, sharing, and exchange between Asia and Africa in support of Sustainable Development of Africa.

## References

- Appiah DO, Akondoh ACK, Tabiri RK, Donkor AA (2018) Smallholders farmers' insight on climate change in rural Ghana. *Cogent Food and Agriculture* 4:1–16. <http://www.cogentia.com/article/10.1080/23311932.208.1436211.pdf/27/April/2018>. Accessed 17 June 2018
- Aruwajoye AS, Ajibefun IA (2013) Assessment of livelihood strategies among households in forest reserve communities in Ondo state, Nigeria. *Int J Sci Eng Res* 4(7):1650–1655
- Ayanlade A, Radeny M, Morton JF, Muchaba T (2018) Rainfall variability and drought characteristics in two agro-climatic zones: an assessment of climate change challenges in Africa. *Sci Total Environ* 630:728–737
- Ayuk ET, Fonta WM, Ichoku HE (2011) Forest income and household welfare in rural Nigeria. <https://unu.edu/publications/articles/forest-income-and-household-welfare-in-rural-nigeria.html#info>. Accessed 20 Nov 2019
- Azeez IO, Ikponmwonba OS, Popoola L, Amusa TO (2010) Land use activities among forest environments' dwellers in Edo State, Nigeria: implications for livelihood and sustainable forest management. *Int J Soc For* 3(2):164–187
- Bassey BJ, Obong LB (2008) The role of non-timber forest products (NTFR) in community livelihoods: a case study of Okiro, Obudu Local Government Area Cross River state, Nigeria. *J Environ Res Policies* 3:98–105
- Carloni AS, Crowley E (2005) Rapid guide for missions: analysing local institutions and livelihoods. Food and Agriculture Organization of the United Nations (FAO), Rome
- Coates J (2013) Build it back better: deconstructing food security for improved measurement and action. *Global Food Secur* 2(3):188–194
- Cooper PJM, Dimes J, Rao KPC, Shapiro B, Shiferawa B, Twomlow S (2008) Coping better with current climatic variability in the rain-fed farming systems of sub-Saharan Africa: an essential first step in adapting to future climate change. *Agric Ecosyst Environ* 126:24–35
- Vidaurre de la Riva M, Lindner A, Pretzsch J (2013) Assessing adaptation – climate change and indigenous livelihood in the Andes of Bolivia. *J Agric Rural Dev Trop Subtrop* 114(2):109–122
- Enete IC (2014) Impacts of climate change on agricultural production in Enugu State Nigeria. *J Earth Sci Clim Change*. <https://doi.org/10.4172/2157-7617.1000234>
- Fadaïro OS, Calland R, Mulugetta Y, Olawoye JE (2017) A corruption risk assessment of reducing emissions from deforestation and forest degradation project in Nigeria. *Int J Clim Change Impact Responses* 10(1):1–22
- Fadaïro O, Williams PA, Nalwanga FS (2019) Perceived livelihood impacts and adaptation of vegetable farmers to climate variability and change in selected sites from Ghana, Uganda and Nigeria. *Environ Dev Sustain*. <https://doi.org/10.1007/s10668-019-00514-1>
- Fisher PA, Paveglio T, Carroll M, Murphy D, Brenkert-Smith H (2013) Assessing social vulnerability to climate change in human communities near public forests and grasslands: a framework for resource managers and planners. *J For* 111(5):1–9. <https://doi.org/10.5849/jof.12-091>
- Idowu AA, Ayoola SO, Opele AI, Ikenweuwe P (2011) Impact of climate change in Nigeria. *Iranica J Energy Environ* 2(2):145–152
- Kinsey J (2005) Will food safety jeopardize food security? *Agr Econ* 32(s1):149–158
- Levang, P., Dounias, E. & Sitorus, S. (2005). Out of the forest, out of poverty? *Forests, trees and livelihoods*, 15(2): 230
- Lindner A, Pretzsch J (2013) An international network on climate change impacts on small farmers in the tropical Andes – global conventions from a local perspective. *Sustain Agric Res* 2(2):92–98. <https://doi.org/10.5539/sar.v2n2p92>

- Malhi Y, Wright J (2004) Spatial patterns and recent trends in the climate of tropical rainforest regions. *Philos Trans Biol Sci* 359:311–329
- Morton JF (2007) The impact of climate change on smallholder and subsistence agriculture. *PNAS* 104(50):19680–19685
- Mwampamba TH (2007) Has the woodfuel crisis returned? Urban charcoal consumption in Tanzania and its implications to present and future forest availability. *Energy Policy* 35 (8):4221–4234
- Nayak BP, Kohli P, Sharma JV (2012) Policy brief: livelihoods of communities and forest degradation in India: issues for REDD<sup>+</sup> policy. <https://www.semanticscholar.org/paper/Livelihood-of-local-communities-and-forest-in-India-Nayak-Kohli/4a45c80a48147a4c607b96905212d6bf5f5622f6>. Accessed 17 Nov 2019
- Osuafor AM, Nnorom NR (2014) Impact of climate change on food security in Nigeria. *Int J Sci Technol* 3(1):1–16
- Petkova EP, Ebi KL, Culp D, Irwin R (2015) Climate change and health on the U.S. Gulf Coast: public health adaptation is needed to address future risks. *Int J Environ Res Public Health* 12:9342–9356
- Petersen EK, Pedersen ML (2010) The sustainable livelihoods approach: from a psychological perspective. Institute of Biology, University of Aarhus
- Power AG (2010) Ecosystem services and agriculture: trade-offs and synergies. *Philos Trans R Soc* 365:2959–2971. <https://doi.org/10.1098/rstb.2010.0143>
- Pretty J, Toulmin C, Williams S (2011) Sustainable intensification in African agriculture. *Int J Agric Sustain* 9(1):5–24
- Saka MG, Jatau DF, Olaniyi WA (2013) Status of indigenous tree species in Girei forest reserve of Adamawa State. *J For Res Wildlife Environ* 5:28–40
- Shackleton CM (2004) Assessment of livelihoods importance of forestry, forests and forest products in South Africa. Rhodes University, Grahamstown
- Somorin OA (2010) Climate impacts, forest-dependent rural livelihoods and adaptation strategies in Africa: a review. *Afr J Environ Sci Technol* 4(13):903–912
- Stringer LC, Dougill AJ, Fraser E, Hubacek K, Prell C, Reed MS (2006) Unpacking “participation” in the adaptive management of social–ecological systems: a critical review. *Ecol Soc* 11(2):39. <http://www.ecologyandsociety.org/vol11/iss2/art39/>. Accessed 12 July 2018
- Sunderlin W, Angelsen A, Belcher B, Burgers P, Nasi R, Santose L, Wunder S (2005) Livelihoods, forests and conservation in developing countries: an overview. *World Dev* 33(9):1383
- Tiani AM, Besa MC, Devisscher T, Pavageau C, Butterfield R, Bharwani S, Bele M (2015) Assessing current social vulnerability to climate change: a participatory methodology (Working paper no. 169). Center for International Forestry Research, Bogor. ISBN 978-602-1504-70-3. <https://doi.org/10.17528/cifor/005463>
- Tompkins EL, Adger WN (2004) Does adaptive management of natural resources enhance resilience to climate change? *Ecol Soc* 9(2):10. <http://www.ecologyandsociety.org/vol9/iss2/art10>. Accessed 17 Aug 2018
- Veenendaal EM, Swaine MD (1998) Limits to tree species distribution in lowland tropical rainforests. In: Newbery DM, Prins HHT, Brown M (eds) *Dynamics of tropical communities*. Blackwell Publishing, Oxford
- Ward RD, Friess DA, Day RH, Mackenzie RA (2016) Impacts of climate change on mangrove ecosystems: a region by region overview. *Ecosyst Health Sustain* 2(4)
- Warner K (2000) Forestry and sustainable livelihoods; what part can forest and forestry play in reducing poverty? *Unsilver: FAO*, 51(202), 3–12
- Wunder S (2005) Forestry and sustainable livelihoods. World Commission on Environment and Development (1999). *Our Common Future*. Oxford University Press, pp 1817

**Open Access** This chapter is licensed under the terms of the Creative Commons Attribution 4.0 International License (<http://creativecommons.org/licenses/by/4.0/>), which permits use, sharing, adaptation, distribution and reproduction in any medium or format, as long as you give appropriate credit to the original author(s) and the source, provide a link to the Creative Commons license and indicate if changes were made.

The images or other third party material in this chapter are included in the chapter's Creative Commons license, unless indicated otherwise in a credit line to the material. If material is not included in the chapter's Creative Commons license and your intended use is not permitted by statutory regulation or exceeds the permitted use, you will need to obtain permission directly from the copyright holder.







# Climate Change, Biodiversity, and Tipping Points in Botswana

# 59

Peter Urich, Yinpeng Li, and Sennye Masike

## Contents

Introduction .....	1194
Tipping Points and Emergence .....	1195
Emergence and Innovation .....	1196
ISEET Analysis Framework .....	1198
Institutional-Socio-Earth-Economical-Technical (ISEET) systems .....	1198
The Working Definition of a Subsystem .....	1199
Case Study: Botswana’s Biodiversity Sector .....	1200
Biodiversity and Tipping Points .....	1202
Baseline Biodiversity in Botswana .....	1207
Biodiversity, Ecosystem Services, and Tourism .....	1210
Climate Change Impacts on the Biodiversity in Botswana .....	1212
One Example: The Okavango Delta .....	1213
Tipping Points for Climate Change for the Biodiversity Sector .....	1214
Results and Recommendations .....	1214
Summary and Conclusion .....	1222
References .....	1223

## Abstract

Climate adaptation planning requires new ways of thinking and approaching the analysis of risks. Such thinking needs to be systemic in nature and practice/action-oriented while respecting the complexity of the physical and social sciences. Through this chapter on climate tipping points in Botswana, it is proposed

This chapter was previously published non-open access with exclusive rights reserved by the Publisher. It has been changed retrospectively to open access under a CC BY 4.0 license and the copyright holder is “The Author(s)”. For further details, please see the license information at the end of the chapter.

P. Urich (✉) · Y. Li · S. Masike

International Global Change Institute and CLIMsystems Ltd, Hamilton, New Zealand

e-mail: [peter@climsystems.com](mailto:peter@climsystems.com); [yinpengli@climsystems.com](mailto:yinpengli@climsystems.com); [sennye@climsystems.com](mailto:sennye@climsystems.com)

© The Author(s) 2021

W. Leal Filho et al. (eds.), *African Handbook of Climate Change Adaptation*,  
[https://doi.org/10.1007/978-3-030-45106-6\\_161](https://doi.org/10.1007/978-3-030-45106-6_161)

1193

that a generic and practice-oriented analysis framework be applied with a mathematical foundation including modeling methods based on complex science. The objective is to promote a framework that privileges a worldview to avoid biased and partial explanations of risks. An Institutional-Socio-Earth-Economical-Technical systems (ISEET) approach is based on a systems science philosophy for risk governance analysis, with particular emphasis on tipping points and emergence which are some of the key elements that can support sound adaptation planning. Through the lens of the biodiversity sector in Botswana, the complex interrelationships of ISEET principles are explained. They provide a new, efficient, and practical framework for moving rapidly from theory to action for planning and implementing climate change adaptation projects.

---

**Keywords**

Tipping points · System dynamics · Climate change · Risk assessment · Biodiversity · Action research

---

**Introduction**

Humanity has modified the earth systems in significant ways and has initiated unprecedented Anthropocene risks (Keys et al. 2019; Baer and Singer 2018). Changes include fundamental aspects of the earth system such as all layers of the atmosphere, hydrosphere, and cryosphere through changes in weather patterns, climate, land surfaces, ocean chemistry, and geological structures. Anthropocene risks such as global connectivity either have reached or are approaching tipping points of various earth systems at different temporal and spatial scales (Steffen et al. 2018). Meanwhile, the emergence of new knowledge, technologies, and institutions has led to new approaches for problem-solving. An example of collective action is the Paris Agreement ratified by the United Nations Framework Convention on Climate Change (UNFCCC). However, progress in mitigating climate risk has not been satisfying. Responses are uneven and uncoordinated, and CO<sub>2</sub> emissions continue to increase globally, even with green energy and other technological advancements. New approaches to the analysis of risks need to be articulated systemically and be practice-oriented while respecting the complexity of the physical and social sciences (Sterner et al. 2019; Lucas et al. 2018).

The existing initiatives and frameworks are limited, such as the Sendai Framework for Disaster Risk Reduction, the Paris Agreement, and international programs such as IRGP-IDHP (Integrated Risk Governance Project-International Human Dimension Programme). These limitations transcend the research frameworks as well, such as SES (socio-ecological system), STS (science technology and sustainability, and IAD (institutional analysis and development). The weaknesses of these existing frameworks as analysis and practice tools are being more widely debated and are modified as society seeks a better understanding of systemic risks posed by climate change and large-scale socio-physical disasters (Cole et al. 2014; McCord et al. 2017).

A more generic and practice-oriented analysis framework is explored from a mathematical foundation, including modeling methods based on complex science. A structure of systems thinking applicable in the Anthropocene is proposed whereby analysis privileges a worldview and earth-view that attempt to avoid biased and partial explanations of risks.

## Tipping Points and Emergence

There are standard features of systemic risks in different domains. These include the character of agents and emergence phenomena, tipping parameters indicating instability, and more noncommittal empirical observations. Instead, these features can be related as Lucas et al. (2018) describe on fundamental theory for relatively well-understood and straightforward systems in physics and chemistry. A crucial mechanism is the breakdown of macroscopic patterns of whole systems due to feedback reinforcing actions of agents on the microlevel, whereby the role of complexity science forms the basis for unifying the phenomena of systemic risks in widely different domains.

Tipping points sometimes also refer to shifting points. For example, the shift from an unsustainable to a sustainable society requires a radical historical change in the form of a profound transition which could involve a series of connected transitions in many socio-technical systems (e.g., energy, mobility, and food) toward sustainability. People who work from an SES point of view, studying the profound transition and radical change issues, use different expressions (Schot and Kanger 2018; van der Vleuten 2019).

According to Lenton et al. (2008: 1786), the term tipping point refers to a “critical threshold at which a tiny perturbation can qualitatively alter the state or development of a system.” The following attributes are identified as tipping points in the Anthropocene:

- Tipping points could impact the whole planetary scale, everything living on Earth.
- Tipping points could impact the transition or the change of regime.
- Interaction crosses boundaries, including administration and nature systems and ISEETS boundaries.
- Both collective and individual social actions operate in multiple sociocultural, technological, governance, biophysical, and knowledge systems which interact with many other systems at the same time and many levels.
- Tàbara et al. (2018) focused on the complexity of attribution and a reductionist approach about systems thinking and the historical drive to an oversimplified explanation of solutions, drivers of tipping points that could improve the likelihood of limiting global warming to either the 1.5 °C or 2 °C target.
- When social and natural scientists collaborate and integrate their studies, new patterns and previously unforeseen relationships that can accentuate understanding have been achieved. Such studies often reveal intricate causes and effects as such works are based on well-defined spatial, temporal, and organizational units,

be they culturally, physically, or politically determined. Another finding in such studies is their non-stationary and as Liu et al. (2009) feedback loops lag in effects from a range of identified causes and their relationship with resilience and thresholds can reveal new insights. It is also recognized that past interrelationships can have spillover effects that can continue to impact on not only a present state of a system but also its future.

- Tipping points are likely to be breached in the future; however, the underlying conditions are challenging to predict, and the accuracy in defining the time and place makes policy and decision-making currently inadequate for either mitigating or possibly avoiding transgressions.
- Thresholds are not constant. Instead, the position of a threshold along a determining variable can change. The consequences of crossing a threshold are context-dependent. The threshold is sometimes known, and the decision-making depends on the effects of crossing it.
- Tipping points or regime shifts are intricately related to the concept of system resilience.

## Emergence and Innovation

Emergence plays a central role in theories related to integrative levels and complex systems. Emergence and emergent phenomena are essential concepts in complexity studies (Goldstein 2018). Emergence can be described as either the development or the presence of the existence or formation of common behaviors, whereby the collective actions within a system would not lead to a similar outcome if applied as individual, constituent parts with no recognized interaction. Emergence is also used to describe the properties of a system – what the system does under its relationship with the environment that it would not otherwise complete itself and is coupled to the scope and system boundaries (Ryan 2007). Emergence also refers to the ability of individual components of a system to collaborate, thus leading to rapid and diverse behavioral changes and new features. For the ISEET, more linkages and communication between subsystems, or the building of more relationships among the ISEET subsystems, could lead to new features emerging. These would then reflect the application of the more complex system and possibly more innovative systems thinking. Emergence is typically not reducible to, nor readily predictable from, the properties of individual system components. Therefore, it may appear surprising or unexpected (Halley and Winkler 2008). Emergent phenomena exist in all subsystems, which could provide solutions or options to the existing challenges in all subsystems if the emergence is managed properly (Ceccarelli et al. 2019; Lichtenstein 2014; Roundy et al. 2018).

Emergence could be applied in a conceptual framework. This framework could improve the understanding of scientific and technological progress (Alexander et al. 2012), innovation, and economic growth (Du and O'Connor 2019). Such a holistic innovation system could improve productivity through the diverse knowledge of

business resources available. Emergence also could be scored to identify the topics and drivers of innovation (Porter et al. 2019).

The technology innovation process is central to effective adaption to climate change and development challenges. However, models from business and management tend to dominate innovation theory, which sits outside the adaption-development paradigm (Hope et al. 2018). The goal is, however, to support the development of sectoral and technologically detailed and policy-relevant country-driven strategies consistent with the UNFCCC Paris Agreement.

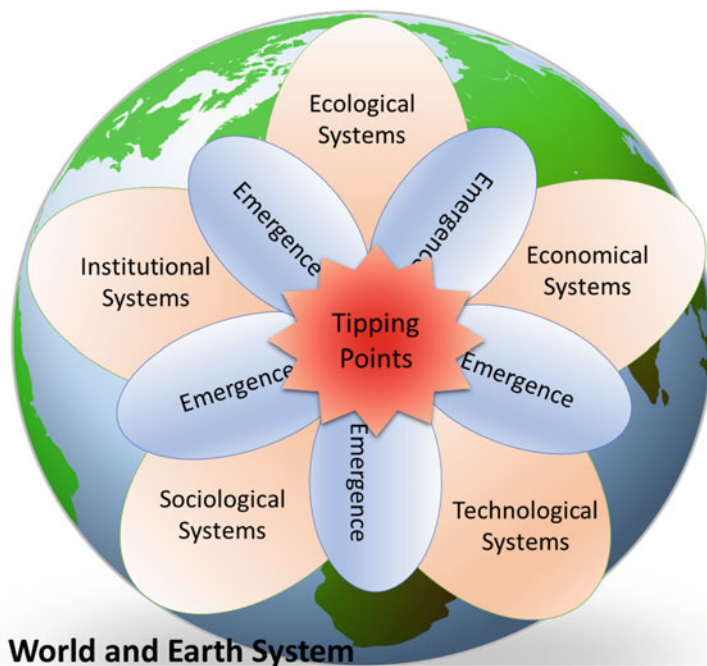
An ISEETS framework can be used to engage stakeholder input and buy-in; design implementation policy packages; reveal necessary technological, financial, and institutional enabling conditions; and support global stock-taking and ratcheting of ambition (Waisman et al. 2019).

Macro-level agreements, such as the UNFCCC Paris Agreement, should be designed to encourage debate on how to tackle climate change through the notion of innovation, applying both technological innovation and marketing issues. Innovation of a technical nature is part of the equation, but it is not the only requirement. It has been suggested by Asayehegn et al. (2017) that an enabling sectoral system of innovation (SSI) be prioritized where some technological innovations contribute to adaptation actions for climate change. Technological impact analysis could be included based on the following approaches: historical sectoral application and improvement on the systems, such as agriculture technology, livestock breeding and feeding technology, ICT technology, carbon sequestration technology, and others where appropriate.

With the emergence of adaptation technology, it can be defined as “the application of technology to reduce the vulnerability or enhance the resilience, of a natural or human system to the risks of climate change” (UNFCCC 2005: 5). Technologies are defined as either “hard” that includes equipment and infrastructure or “soft” such as institutions and management systems (Christiansen et al. 2011). However, some technologies, such as new crop varieties, are not so easy to categorize. Many technologies can be used to address current vulnerabilities to climate and other environmental, economic, and societal concerns and to reduce future exposure to climate change impacts. Some can also be used to address several types of climate change impact in different sectors.

ISEET modeling seems too big to be handled by either a single model or an existing framework. However, when considering specific modeling for a risk governance issue, the data, variables, and parameters could be selected and refined according to their importance and their functionalities. The modeling approaches from different disciplines could be either simplified or reorganized to fit specific purposes. For the subsystem in this chapter, the modeling approaches have been developed for specific contexts, which can be either absorbed or integrated into the ISEET modeling processes.

Modeling systemic or structural change in socio-environmental systems is not new. Tipping point modeling has been carried out by scientists from SES, climate systems, social systems, network analysis, and agent-based modeling disciplines. Based on the ISEET system analysis framework, Fig. 1 depicts an overview of an



**Fig. 1** The framework of Institutional-Socio-Economic-Ecological-Technological Systems (ISEETS) for a climate change tipping point study. (Source: authors)

ISEET structure for tipping points and the emergence of, and linkages between, five subsystems.

Tipping points and regime shifts are being studied within various disciplines applying a range of modeling approaches and analysis frameworks. One of the first obstacles in any study of systemic change is the terminology. Environmental and social science disciplines have engaged in relevant ideas of regime shift, structural change, non-marginal change, and transition theory, and each claims ownership (Polhill et al. 2016).

---

## ISEET Analysis Framework

### Institutional-Socio-Earth-Economical-Technical (ISEET) systems

ISEET describes five intrinsically interlinked systems formed around the Anthropocene. The method has at its foundation systems science concepts and mathematical methodologies for risk governance analysis, with emphasis on tipping points and emergence, which are the key characteristics that need to be analyzed for risk governance.

ISEET represents a dynamic system. Their elements, functions, and relationships change with time and across spatial scales. Historical evidence and future prediction are essential for risk governance. Human beings do not always passively react to risks. With new and different technologies and the extension of knowledge, the risk may become more manageable. Opportunities could be created through the emergence mechanism in ISEET.

ISEET systems can be characterized as the coupling of natural laws with world rules. The goals are to support mutual well-being of the earth (physical) and world (social) systems. To describe risk governance issues in the Anthropocene, ISEET framework subsystems are indispensable. ISEET risk governance is either realized or implemented by institutions. They require the full engagement of societies and apply certain economically viable technologies that should encompass sustainable ecosystem service support from the earth environment and its resources.

From the subsystem point of view, the interrelationship could be described as:

- An institution that must have close collaboration with its relational society, using environmentally and ethically sound and economically viable technologies.
- Societies that could live with the environment, given effective and efficient institutions, and be economically healthy, with controllable risks on the earth system.
- Societies that need to work together to advance and apply technologies with economic endeavors, to live sustainably with the earth system.
- The sustainable development of economic systems that could be achieved by a well-designed and well-operated institution, which include social capital and earth resources.
- Technology that may need to be advanced and applied and that does not harm the environment and is ethically healthy. In this way, societies are more likely to promote institutions, with the input from their constituent economic systems.

### **The Working Definition of a Subsystem**

- An institution in ISEET implies a body that operates within regulations, laws, policies, and conventions. Such institutions can represent cross-sectoral entities established when either developing or implementing a related risk governance framework. For example, emergency management laws and emergency management ministries are all part of a larger institutional system.
- Social systems in ISEET refer to all the elements, functions, and relationships in societies, including the population and its age and gender composition, culture, religion, educational level, and connectivity. Complexity theory offers the toolkit needed for this paradigm shift in social theory (Walby 2007).
- Earth system refers to the biophysical existence of the Earth planet, including the living support environment, from top air to deep earth.
- An economic system, as defined by Gregory and Stuart (2013: 30), “is a system of production, resource allocation and distribution of goods and services within

a society or a given geographic area. It includes the combination of the various institutions, agencies, entities, decision-making processes and patterns of consumption that comprise the economic structure of a given community.”

- Technological systems are sets of interconnected components that transform, store, transport, or control materials, energy, and information for specific purposes. Machines, software, and the hardware they run on are considered part of a technological system. Similarly, how humanity organizes itself to apply such technology are broader arrangements based on the organization’s structures to exploit technology and techniques developed to optimize their application.

---

## Case Study: Botswana’s Biodiversity Sector

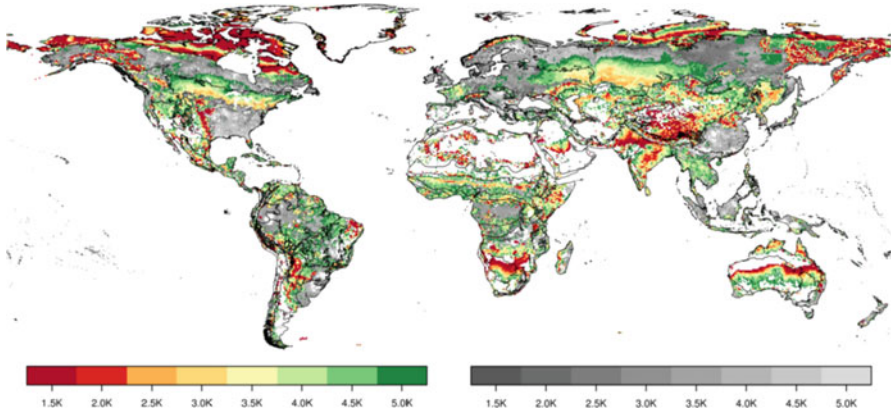
Time is of the essence for engaging in the intersection between climate change and the biodiversity extinction crisis. The Global Deal for Nature (GDN) is one opportunity as it is science-driven with the goal of saving the diversity and current relative abundance of life on the planet. The linkage of the GDN with the Paris Climate Agreement might help humanity avoid catastrophic climate change while conserving species and their increasingly recognized values, including ecosystem services.

Compelling recent findings add additional urgency to the issue as less than half of the globe’s terrestrial realm is intact. The application of global climate points toward a tipping point. Habit conversions continuing as they were historically while greenhouse gas emissions maintaining its current trajectories may exceed humanity’s chances of limiting global warming to the 1.5 °C target. Over the next 10 years, currently expanding conversion and poaching rates need to be slowed down considerably to avoid “points of no return” for some floral and faunal species (Fig. 2).

If global mean temperatures are permitted to rise above 1.5 °C, it is widely believed that fundamental aspects of ecosystems, both large and small, could unravel. Continued unsustainable use of the natural environment threatens our global health as witnessed by the rising risk of global pandemics, while mass migration owing to the lack of access to resources such as clean water and productive and uncontaminated land become more widespread. Global climate change and its increase in extreme events could accelerate the degradation of land and societies. For example, climate change-induced sea level rise and extreme still high-water events, which inundate coastal zones and droughts, may displace at least 100 million people by 2050. Most of those people currently live in the southern hemisphere (Dinerstein et al. 2019).

Botswana, as part of Southern Africa, is home to an appreciable portion of global biodiversity, and many of its ecosystems retain relatively intact species assemblages across all trophic levels. The region possesses an established network of protected areas that contribute both to conservation targets and to nature-based tourism. Pressure on biodiversity can result from regional and highly localized developments concerning extractive resource use. Anthropogenic climate changes are more widely accepted as a profound driver of such impacts for Africa’s biodiversity, including





**Fig. 2** Thresholds of temperature anomaly that could lead to significant local changes in land-based ecosystems. Colored areas (left legend) represent regions with severe transformation; gray areas (right legend) are likely to experience moderate transformation. Dark red transformation at 1.5 °C and light red at 2.0 °C. (Courtesy of Gerten et al. 2013)

Botswana, and it is increasingly likely to be harmful from both ecological and economic perspectives.

Worldwide, the United Nations is committed to mainstreaming biodiversity planning in a wide range of policies and programs and with the inclusion of climate change. In a country such as Botswana, mainstreaming biodiversity and/or wildlife management at the local, regional, and country level is critical to its economy and its place as a critical biodiversity REDD hotspot for several primary faunal species.

Botswana, in terms of biodiversity, is a country of contrasts. The diversity ranges from the wetlands of the north, dependent on water arriving season from neighboring Angola, to the broad and arid Kalahari Desert in the center and southwest. Each area is part of a systematic protected area system with the Okavango Delta representing the world's largest inland delta which is also a Ramsar site. At the same time, Chobe National Park has many varieties and populations of game and a considerable density of elephants. The country has innovated the first formally declared transboundary park in Africa, the Kgalagadi Transfrontier Park. There is also the Central Kalahari Game Reserve and the distinctive prehistoric lake that now consists of salt pans called the Makgadikgadi and Nxai Pans National Park system. This area has important habitats for migratory birds.

Botswana is developing a National Climate Change Policy, Strategy and Action Plan (NCCPSAP) with the framework for such being only recently devised. The policy will be implemented through the Ministry of Environment, Wildlife and Tourism in cooperation with the United Nations Development Programme. Among other objectives, the NCCPSAP aims to develop and implement appropriate adaptation strategies and actions that will lower the vulnerability of Botswana and various sectors of the economy to the impacts of climate change.

## Biodiversity and Tipping Points

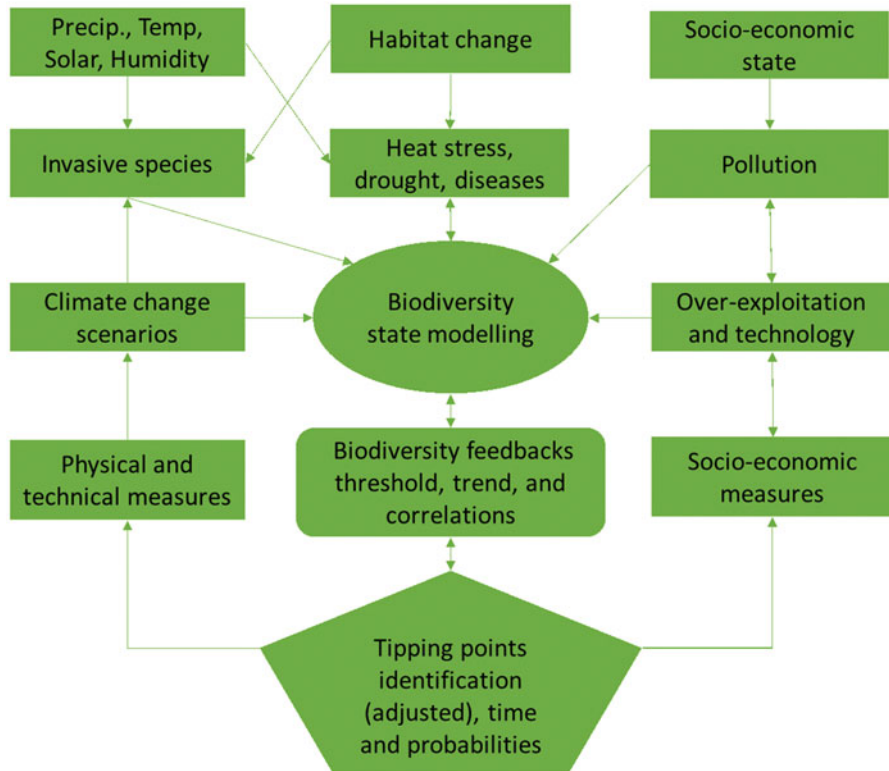
Biodiversity in the context of tipping points is a complex area for investigation. Alternate stable states are associated with abrupt shifts in ecosystems, tipping points, and hysteresis, all of which challenge traditional approaches to ecosystem management (Oliver et al. 2015). Ecosystems often maintain their stability through internal feedback mechanisms. Environmental perturbations (natural and enhanced by climate change) can change the frequency and magnitude of regime shifts leading to fundamental changes in the assemblages of species providing functions.

Systems can be more susceptible to environmental randomness/irregularity and perturbations/fluctuation close to these critical tipping points and can lead to sudden changes and foster a new equilibrium. Such evolved alternative stable states might be unsupportive in terms of ecosystem functions with a return to a previous state only possible through substantial and costly management interventions (hysteresis). Therefore, the recovery capacity of ecosystem function can be compromised. Alternative conditions have been documented in a wide variety of ecosystems from local to global scales. However, how stable and persistent these will be in the future, under rapid changes in climate, remain uncertain.

It is exceedingly difficult to understand how complex ecosystems, for example, the Okavango Delta, will behave as they either approach or surpass tipping points (Fig. 3). Exceedingly small changes in one or more conditions can lead to a cascade of other changes resulting in a large shift in the state of the system. Sometimes this process can be played out very slowly and therefore less perceptibly by society, and at other times, extreme events lead to radical shifts that exceed the capability of systems to slowly recover, and hence it is forced to find a new stasis; this is a natural process with volcanic eruptions, earthquakes, and flood events often leading to abrupt changes. However, climate change and its speed of onset, which varies from location to location, and the uncertainty in future projections can lead to management paralysis. The slowing down of a potentially catastrophic collapse of individual and highly relevant parts of a system is therefore preferred to prolong the sustainability of the large system.

Ecosystem management depends on monitoring and maintaining resilience because the loss of resilience renders ecosystems more vulnerable to undesirable shifts. Several works summarized by Dai et al. (2012) suggest that a set of generic indicators may aid in the sustainable management of fragile ecosystems. Signals of critical slowing down based on time series demand observations over a long span. Compiling such data is often tricky; therefore, if other indicators based on the spatial structure can be identified, they could be complementary to the early warning signals.

Tipping points are often driven by either complex feedback mechanisms or interactions between multiple drivers. Some of these triggers or drivers are found to be new and thus are not well represented in models currently in use (Leadley et al. 2010). An example is a relationship between dying back in Amazon forests and deforestation and climate change processes that resulted in an underestimation of impacts in earlier global biodiversity assessments. This situation may pertain in the



**Fig. 3** Tipping point analysis framework for biodiversity in Botswana. (Source: authors)

case of the Okavango Delta where the sustained integrity of the Miombo woodlands on neighboring country of Angola leaves the well-established ecotourism focal areas such as the Okavango swamps in Botswana critically dependent on the sustained flow of sediment- and nutrient-free water from those upland parts of the wider river basin (Leadley et al. 2010).

Ecosystem service degradation can be linked with species extinctions, eroding species abundance, or as shown in this chapter potential shifts in biomes and associated species distributions. However, conservation of biodiversity and provision of some types of ecosystem services can conflict. The following tables list the already identified changes (from 2008 to 2019) in red category lists for plants and animals in Botswana in a limited African context (Tables 1, 2, and 3).

Midgley and Thuiller (2011) suggest significant impacts from unrestrained climate change for the southern part of the African region. However, overestimates of the speed of change and extent of those impacts may be the case owing to underlying assumptions of bioclimatic modeling. The analysis of a diverse range of studies does, however, support the rationale for a high level of concern as there is a signal across the available research that unmitigated changes in climate threaten a

**Table 1** Red List Category summary country totals (plants) by the number of extinct, threatened, and other species of plants in each Red List Category in each country (IUCN 2008, 2019)

	EX	EW	Subtotal	CR	EN	VU	Subtotal	LR/cd	NT	DD	LC	Total
Sub-Saharan Africa												
Angola 2008	0	0	0	0	2	24	26	0	6	1	6	39
Botswana 2008	0	0	0	0	0	0	0	0	3	0	3	6
Angola 2019	0	0	0	0	4	32	36	14	0	38	859	947
Botswana 2019	0	0	0	0	1	2	3	2	0	8	398	411

**IUCN Red List Categories:** *EX* extinct, *EW* extinct in the wild, *CR* critically endangered, *EN* endangered, *VU* vulnerable, *LR/cd* lower risk/conservation-dependent, *NT* near threatened (includes *LR/nt* lower risk/near threatened), *DD* data-deficient, *LC* least concern (includes *LR/lc* lower risk/least concern)

**Table 2** Red List Category summary country totals by numbers of threatened species (critically endangered, endangered, and vulnerable categories only) in each major taxonomic group by country (IUCN 2008, 2019)

Sub-Saharan Africa	Mammals	Birds	Reptiles*	Amphibians	Fishes*	Mollusks*	Other inverts*	Plants*	Fungi and protists*	Total*
Angola 2008	14	18	4	0	22	4	1	26		89
Botswana 2008	<b>6</b>	<b>7</b>	<b>0</b>	<b>0</b>	<b>2</b>	<b>0</b>	<b>0</b>	<b>0</b>		<b>15</b>
Angola 2019	19	32	7	0	53	7	4	36	0	158
Botswana 2019	<b>11</b>	<b>16</b>	<b>1</b>	<b>0</b>	<b>2</b>	<b>0</b>	<b>0</b>	<b>3</b>	<b>0</b>	<b>33</b>

\*Reptiles, fishes, molluscs, other invertebrates, plants, fungi & protists: please note that for these groups, there are still many species that have not yet been assessed for the IUCN Red List and therefore their status is not known (i.e., these groups have not yet been completely assessed). Therefore the figures presented below for these groups should be interpreted as the number of species known to be threatened within those species that have been assessed to date, and not as the overall total number of threatened species for each group

**Table 3** Red List Category summary country totals (animals) by the number of extinct, threatened, and other species of animals in each Red List Category in each country (IUCN 2008, 2019)

Sub-Saharan Africa	EX	EW	Subtotal	CR	EN	VU	Subtotal	LR/cd	NT	DD	LC	Total
Angola 2008	0	0	0	9	19	35	63	0	50	114	1,384	1,611
Botswana 2008	<b>0</b>	<b>0</b>	<b>0</b>	<b>1</b>	<b>1</b>	<b>13</b>	<b>15</b>	<b>0</b>	<b>21</b>	<b>12</b>	<b>847</b>	<b>895</b>
Angola 2019	0	0	0	12	33	77	122	60	0	233	2,493	2,908
Botswana 2019	<b>0</b>	<b>0</b>	<b>0</b>	<b>4</b>	<b>7</b>	<b>19</b>	<b>30</b>	<b>29</b>	<b>0</b>	<b>10</b>	<b>1,010</b>	<b>1,079</b>

**IUCN Red List Categories:** *EX* extinct, *EW* extinct in the wild, *CR* critically endangered, *EN* endangered, *VU* vulnerable, *LR/cd* lower risk/conservation-dependent, *NT* near threatened (includes *LR/nt* lower risk/near threatened), *DD* data-deficient, *LC* least concern (includes *LR/lc* lower risk/least concern)

considerable portion of southern African biodiversity. It is the underlying shifts in ecosystem structures, for example, increases and decreases in woody plant cover, that have a secondary impact on faunal diversity that is likely to alter the dominant savanna vegetation type of the region. Midgley and Thuiller (2011) pointed to the winter rainfall areas of the broader region that could suffer the most significant biodiversity loss. The trends identified in Botswana are echoed in other biomes. It is increasingly recognized that rates of disturbance vary with time and can depend on long-term climate trends, the influence of anthropogenic land-use practices (e.g., fire), wildlife population cycles, and other factors such as presence or introduction of invasive species (Wilson et al. 2019). As noted by Wilson et al. (2019), assessment of regional patterns and trends is needed, hence our approach that placed Botswana in the context of Southern Africa. Specifically, some crucial areas are mostly outside Botswana, but they have relevant spillover effects, especially for the Okavango Delta.

Specifically, when mammals in the region are differentiated by size and dietary requirements, some more telling climate risks emerge. Correlations are significant for annual temperature but only for large mammals, where 60–67% of the variability in species richness of large mammals is impacted versus <20% for small mammals (Andrews and O'Brien 2000). Small mammals are, however, strongly correlated with other either climatic or vegetation parameters. Plant richness, thermal seasonality, and frugivorous and insectivorous mammal richness are found to be correlated with thermal seasonality and minimum monthly PET (potential evapotranspiration). It is also found that arboreal and aerial species richness is associated with plant richness, thermal seasonality, and minimum monthly PET.

It is clear from Andrews and O'Brien's work (2000) that different classes of mammals respond to climatic and environmental factors in important ways. Earlier studies they contend did not identify these discrepancies, as the distinction between various sizes and guilds of mammal was not a common factor of analysis. With climate change, there will be issues across the diversity of mammalian species that should impact on their conservation in the future. This also points to the complexity of communities and the understanding of the potential importance of indicator species, whereby either a mammal's or other organisms' presence, absence, or abundance reflect on the environmental condition of either the ecosystem or biome. Such species can serve as critical indicators of tipping points in either an ecosystem or biome and act as a proxy for the health of that environment in the face of a changing climate.

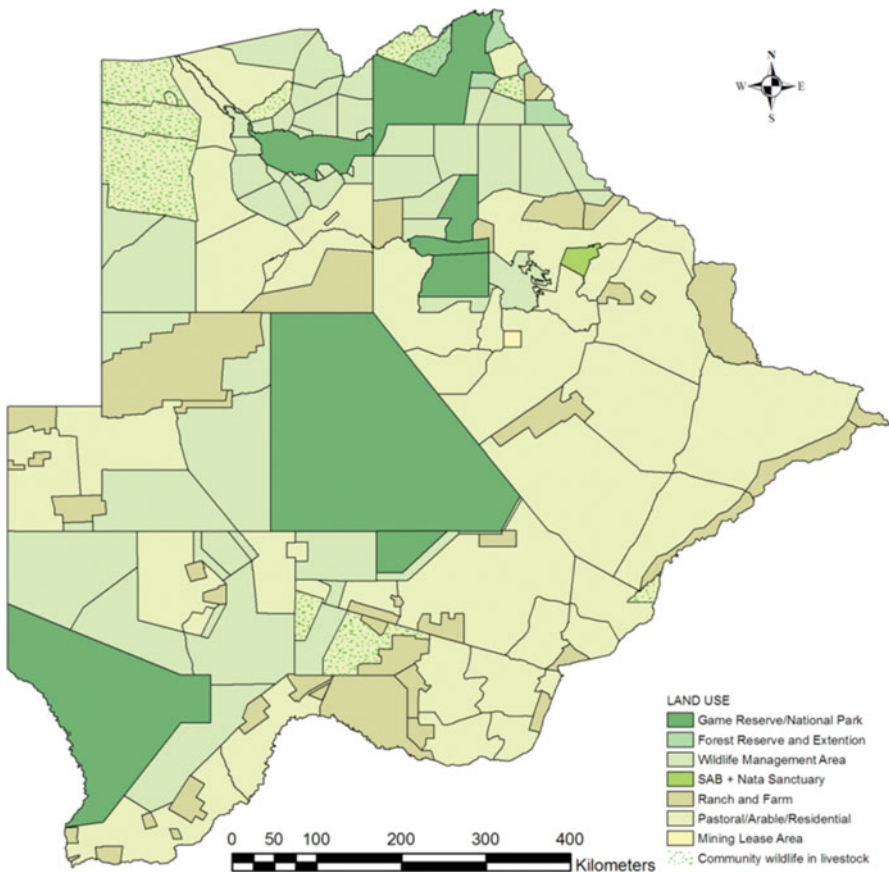
---

## Baseline Biodiversity in Botswana

Wide-ranging large carnivores are common in Botswana. They often range beyond the boundaries of protected areas into human-dominated areas. The mapping out on a country-wide scale and identifying areas with potentially high levels of threats to extensive carnivore survival is required when formulating national conservation action plans whether considering climate change or not. For this chapter, NPP (net

primary production) in a historical context (and later in the context of climate change) has been linked with species biodiversity and richness.

This was done as the notion of NPP was linked with the country's large carnivore guild as part of a recent mapping project. In that project, Winterbach et al. (2014) identified and mapped areas consisting of leopard (*Panthera pardus*), lion (*Panthera leo*), cheetah (*Acinonyx jubatus*), brown hyena (*Hyaena brunnea*), spotted hyena (*Crocuta crocuta*), and African wild dog (*Lycaon pictus*) (Fig. 6). They discovered through this mapping project that habitat suitability for large carnivores depended primarily on prey availability but with secondary relationships with interspecific competition, plus conflict with humans. Winterbach et al. (2014) found that prey availability was a critical natural determinant. Wild ungulate species were preyed upon by the six large carnivores, and this helped to identify different management zones for large carnivore populations. The relationship with large ungulates and NPP



**Fig. 4** Land-use zones in Botswana. (Courtesy of Winterbach et al. 2014)



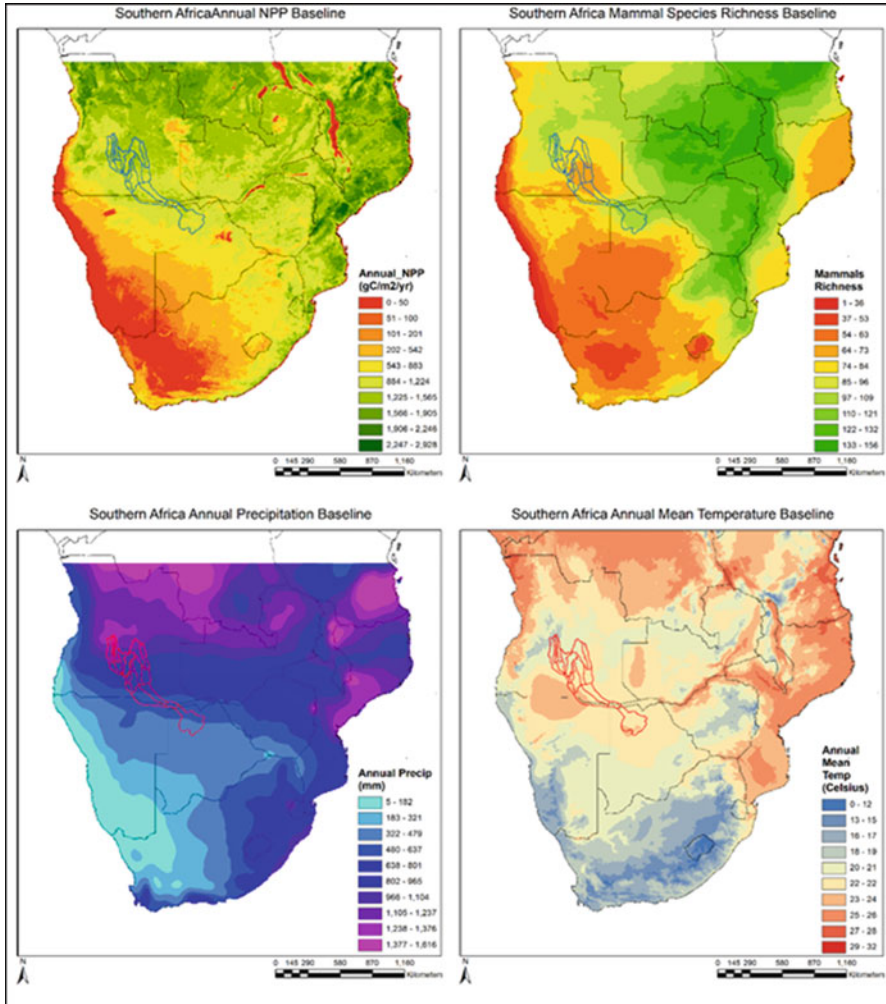
in the country is strong. Therefore, small prey biomass was more evenly spread across large parts of the country, while high to medium biomass of large prey was primarily confined to conservation zones (Figs. 4 and 5).

As Botswana is central, both geographically and in terms of species biodiversity of the larger Southern African sub-Congo basin, its ecological system was deemed prudent to map changes in net primary production and species richness regionally. Changes historically and in the future in these factors will mean transboundary issues will ensue. It is evident in Fig. 6 that mammal species richness is linked with regional phenomena such as NPP, annual precipitation, and mean changes in temperature. The future will be different; hence, some biome shifts from areas currently outside the borders of Botswana could encroach into Botswana over time and as temperatures rise. Clearly, this could lead to critical transboundary implications for management of the subsequent changes in floral and faunal biodiversity.

Future changes in the three zones of species richness in Botswana (Fig. 7) across three key indicator groups, mammals, birds, and amphibians, show clear patterns from the southwest (low richness across all three groups nationally) to moderate richness in the east and high richness in the north. Importantly, these three zones are not national boundary bound but extend to neighboring countries as shown in Fig. 7.



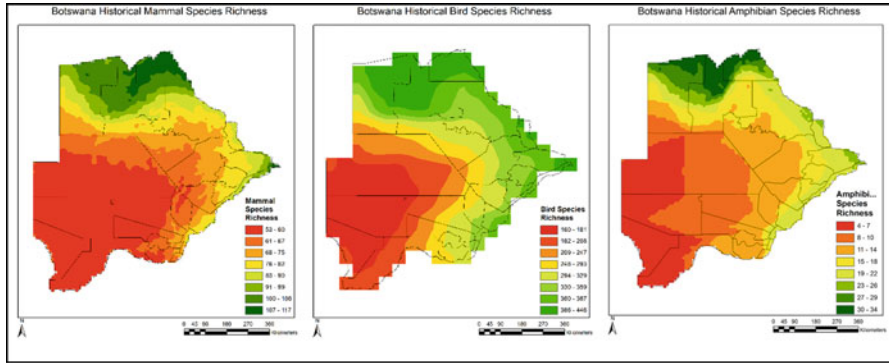
**Fig. 5** Entrance to Moremi Reserve. (Source: authors)



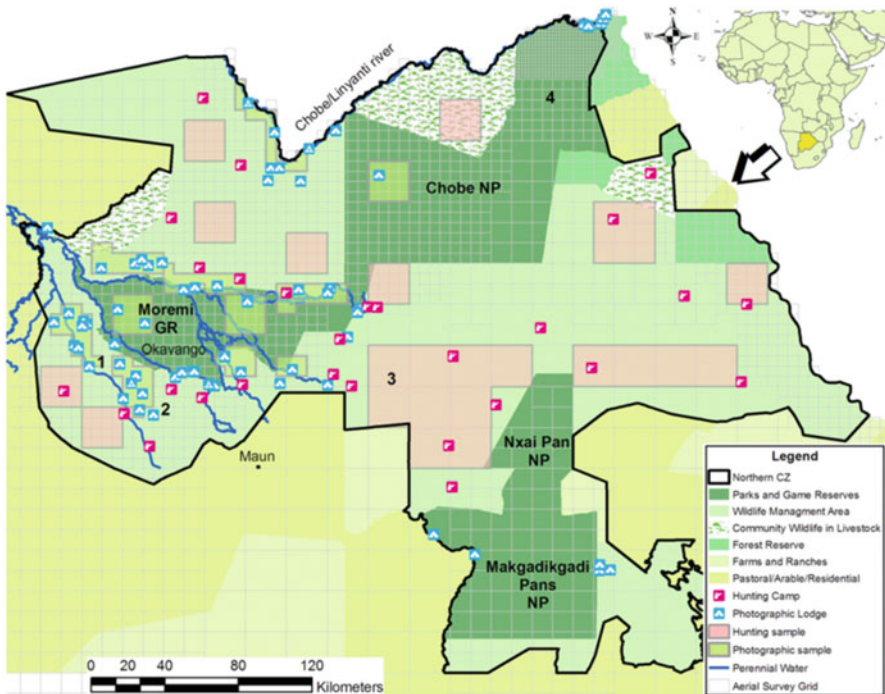
**Fig. 6** Baseline NPP and the relationship between high values and mammal-specific richness, annual precipitation, and annual mean temperature. The Okavango River Basin that supports the Okavango Delta in Botswana is included as it is a key transboundary basin for Botswana species diversity and concomitant tourism and economic activities. (Source: authors)

## Biodiversity, Ecosystem Services, and Tourism

Wildlife tourism in Botswana has provided strong economic incentives for conservation. With an abundance of wildlife and either the presence or absence of high-profile species, some zones are more suited to wildlife tourism. Winterbach et al. (2014) developed a set of parameters for assessing wildlife abundance and diversity.



**Fig. 7** Historical mammal. Bird and amphibian species richness highlight three key zones, the southwest (low), east (moderate), and north (high), and these three regions extend to neighboring countries. (Source: authors)



**Fig. 8** Locations of photographic and hunting camps and land uses in northern Botswana in 2005. (Courtesy of Winterbach et al. 2015)

Their goal was to evaluate tourism potential in Botswana's Northern Conservation Zone. They also quantified and compared tourism experiences in areas with high and low tourism potential. Wildlife biomass is used as an indicator of NPP, and actual tourism experiences were included in their study to validate their mapping exercise.

Winterbach et al. (2014) found that areas used for high-paying/low-volume tourism had significantly higher mean wildlife biomass and diversity (Fig. 8). Only 22% of the Northern Conservation Zone against their framework had intermediate to high tourism potential. High tourism potential areas afforded tourists better wildlife sighting based on aerial survey data than low wildlife sights based on ground surveys. They also found that the economic viability of low-paying tourism may not even be met in zones with intermediate to high tourism potential. Much of the Northern Conservation Zone was found to have low tourism potential; however, this does not equate with a low conservation value.

---

## Climate Change Impacts on the Biodiversity in Botswana

Africa is expected to be particularly severely impacted by climate change (IPBES 2018). Biggs et al. (2008) assessed the impacts on terrestrial biodiversity using the Biodiversity Intactness Index (BII). This index defines an average change in population size against a pre-modern state, across all terrestrial species of plants and vertebrates. In the next 100 years, they projected a decline in average population sizes of taxa that exceed by two to three times the decline that occurred since circa 1700. A reduction in this modeled declines of biodiversity loss in southern Africa posed considerable challenges. Better alignment is needed for integrated biodiversity conservation and development priorities in the region. Furthermore, what is thought to be required are context-sensitive conservation targets that account for the development of imperatives in different parts of the region.

The predominant climate signal from the climate models for southern African is for a hotter and drier future. This is having, and will likely continue to pose, serious consequences and challenges for policy development and management of environmental and related social change for the people of the region. Historical climate records, as indicated, fit reasonably well with future projections for the region, with the important caveat that temperature rises are trending faster than the global mean, especially in continental interiors such as Botswana. Rainfall, however, apparently has not changed significantly, as yet although the combination of higher temperatures and the potential for changes in the variability of rainfall (e.g., more intense) and also changes in seasonality has already shown changes in the trends in vegetation trajectories in the major biomes of southern Africa. Contrary to early projections for the Succulent Karoo biome, biomass and cover increased over time. This was mainly deemed in response to changes in land-use practices. MacPherson et al. (2019) also found that the fire-adapted fynbos biome either remained stable or increased over time with some expansion of forest species.

Meanwhile, and in the same study, it was found that the shrub-dominated Nama-Karoo biome increased in grass cover. Significantly, and in contrast with earlier

model predictions, the grassland biome has expanded westward into former Nama-Karoo biome sites. Regionally, the predominant savanna biome has experienced a relatively rapid increase in woody plants at rates initially unexpected by climate/vegetation models (MacPherson et al. 2019). The availability of new model parameters for biomes and net primary production also provide a useful context for evaluating future changes and for considering tipping points.

Climate change and adaptation have also become a significant issue in contemporary tourism development and policy discussions. This is particularly the case in Botswana and the broader geography of Southern Africa where wildlife in its natural environment dominate the sector. A study on perceptions of climate change (Saarinen et al. 2012) and adaptation strategies of tourism operators in Kgalegadi South District, of southwest Botswana, which also looked at their adaptation strategies, found a general awareness, but the research was conducted nearly 10 years ago. At that time, most operators did envisage challenges to future business growth and Botswana's tourism competitiveness. The perception is that climate change did not at that time have any impacts and that few adaptation strategies were in place. Anecdotal evidence from the consultant's time spent in the Okavango Delta (2019) with a tourism operator of considerable experience pointed to heightened concern regarding climate change. However, problems with earthquake impacts and climate change were signaled as underlying factors in reduced water flow into various parts of the Delta.

### **One Example: The Okavango Delta**

The Government of Botswana has adopted a policy of economic diversification, which is reflected in the National Development Plan 8. There is a strong emphasis on the sustainable use of renewable resources such as veld products and wildlife. Tourism has been identified as a potential "engine for growth" (Jones 2017) and that tourism is based on wildlife and nature experiences. There is an increasing emphasis on the conservation and sustainable use of these resources with a strong geographic focus on the Okavango Delta.

There are significant variations in the size of the actual wetland seasonally as well as from year to year, depending on rainfall intensities in the watershed and other factors (McCarthy 2003). About half of the wetland is permanently inundated, whereas the other half is only seasonally flooded (Anderson et al. 2003); the two areas are referred to as the permanent swamp and the seasonal swamps, respectively.

The Okavango Delta is important ecologically as well as economically. The remoteness, spectacular landscape, and richness in wildlife make the Okavango Delta a magnet for tourists, and tourism has become the second most important sector of the Botswana economy.

Climate change and development-induced land-use change are explicit threats to sustaining biodiversity (Newbold 2018). Modeling and data limitations have hampered a better understanding of the underlying systemic risks. Also problematic are the quite different scales at which land-use and climate processes operate. Newbold



**Fig. 9** Differentiation in water distribution within the Delta. (Source: authors)

(2018) predicted that climate change effects will become a significant pressure on biodiversity and could exceed the effects of land-use change by 2070. Both pressures were predicted to lead to an average cumulative loss of 37.9% of species from vertebrate communities under a “business as usual” scenario with an uncertainty range from 15.7% to 54.2%. The biomes to face the most significant pressures were tropical grasslands and savannahs (Fig. 9).

---

## Tipping Points for Climate Change for the Biodiversity Sector

### Results and Recommendations

Climate change is already well advanced in Botswana and has already created new challenges for biodiversity conservation. Evidence shows that two key elements that are driven by changes in climate are in a national-scale tipping point analysis: shifting biomes and changes in species composition that relates to net primary production of specific environments. Owing to the complexity of biodiversity and variability of species richness across the country, it was only possible to define broad relationships in terms of potential tipping points.

As mentioned, the dominant relationship between net primary production and biome shifts with the potential to support stable biodiversity mixes is complicated. Natural succession of species must be disentangled from a complex web of confounding factors including a plethora of human factors as well as a relatively rapid change in climate regimes. There appears to be emerging a maturing of the science related to shifts on biomes with changes in climate and signals are thus becoming more transparent that climate has a more dominant role to play in the transition of landscapes and hence biodiversity.

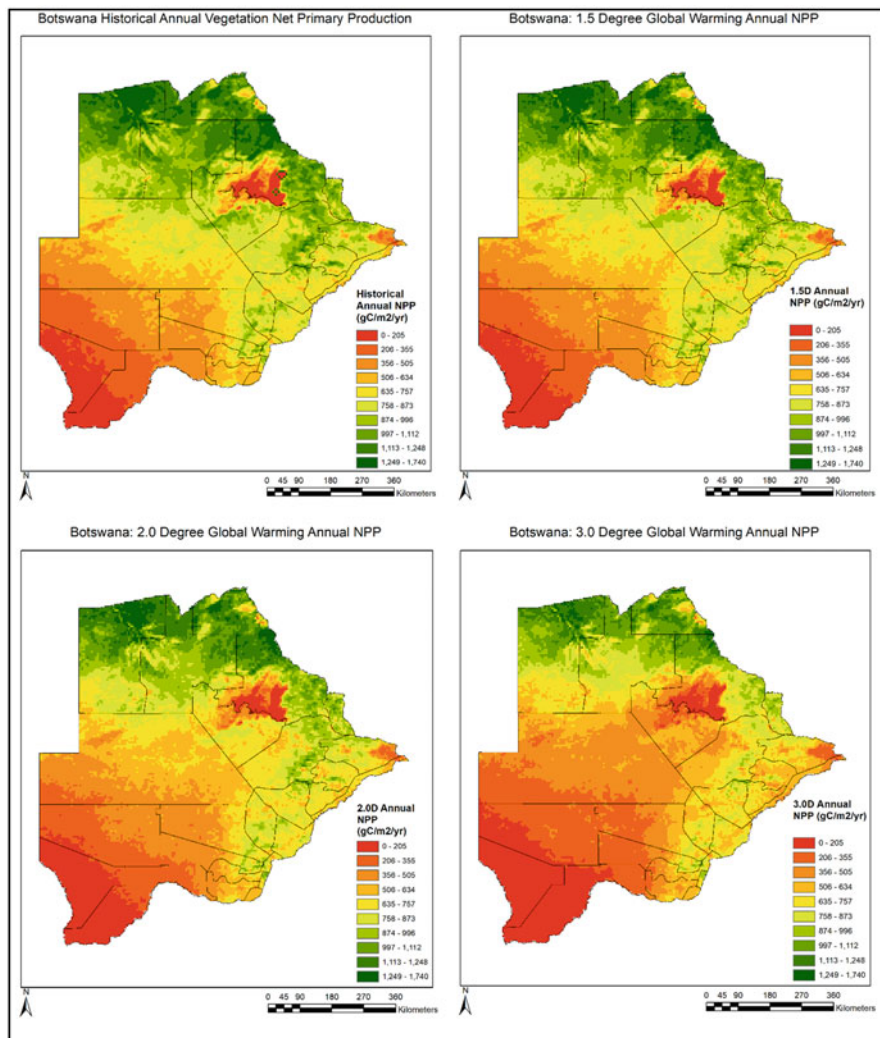
The mapping of mammalian, bird, and amphibian species in Botswana (Fig. 7) with modeled climate-induced changes in net primary production provides insights into possible future changes as temperatures continue to rise regionally. Of note, the temperature profiles of 1.5 °C, 2.0 °C, and 3.0 °C are presented in the introduction and are expected to be reached under current business as usual scenario (84th percentile) (RCP 8.5) in roughly 2028, about 2036, and around 2050,

respectively. There will, of course, be lag times in the response regarding average net primary production in the regions and subsequent potential shifts in biodiversity, barring any management interventions and other human dimensions of change that could ensue over the next 30 years.

The trend in net primary production, which is a driving factor in species richness, is for expansion from southwest to northeast of the lower productivity zone. Concurrently, across all three future temperature profiles, the higher NPP areas of the east and north also become progressively less productive. The same trends are then seen in Fig. 7 where the mammalian species richness diminishes nationwide, i.e., there are no parts of the country that with a temperature change should expect to see an expansion in species richness under natural conditions and changes in the net primary production. Again, these projections are made barring human dimensions of change and its management interventions. The same situation pertains to bird and amphibian species richness with a general overall reduction nationwide but with a general trend of a decline in net primary production from the southwest to northeast.

The change in NPP and species richness while following these trends also presents the opportunity to look contemporarily at areas with current NPP and species richness and consider how economic development strategies may intersect when the conditions found in one area expand into others and transition other biomes and communities. Therefore, there are current activities in the zones that will develop that may present insights for the future as these zones shift into new geographies. Given the relative homogeneity of the Botswanan topography, such transitions could expect to vary relatively little from current forms as they expand. Importantly, there is a change in NPP at the 3.0 °C tipping point that is different. In all the species richness projections (Fig. 7) at this degree of warming, a new low-end species richness category could exist in Botswana that is currently not represented. This is presented in the species richness maps as the 42–48 category for mammalian and bird species richness and the 2–4 range for amphibian species richness. Areas with these ranges of species richness could be found to the west and southwest of Botswana currently, but analysis would need to be done to see if these are, in fact, presently located in the broader region or this new low-end category is currently unknown in the area (Figs. 10, 11, 12, and 13).

Related to the shifts in NPP and species richness described above, the ranges and ecological dynamics of the country are changing, and current reserves will possibly struggle to support all species they were designated to sustain. Climate is, however, just one of the myriads of ISEET issues that impinge on the sustainability of Botswana's biodiversity. Action to mitigate the deterioration in biodiversity varies by spatial scale and the actors required. It is generally viewed that adaptation will require more and better regional institutional coordination, which broadens spatial and temporal perspectives with climate chance scenarios being considered as integral to the planning of actions. Local communities are critical to attaining conservation goals, as there are multiple threats to success. Regional planning, site-scale management, and the continued assessment and modification of conservation plans

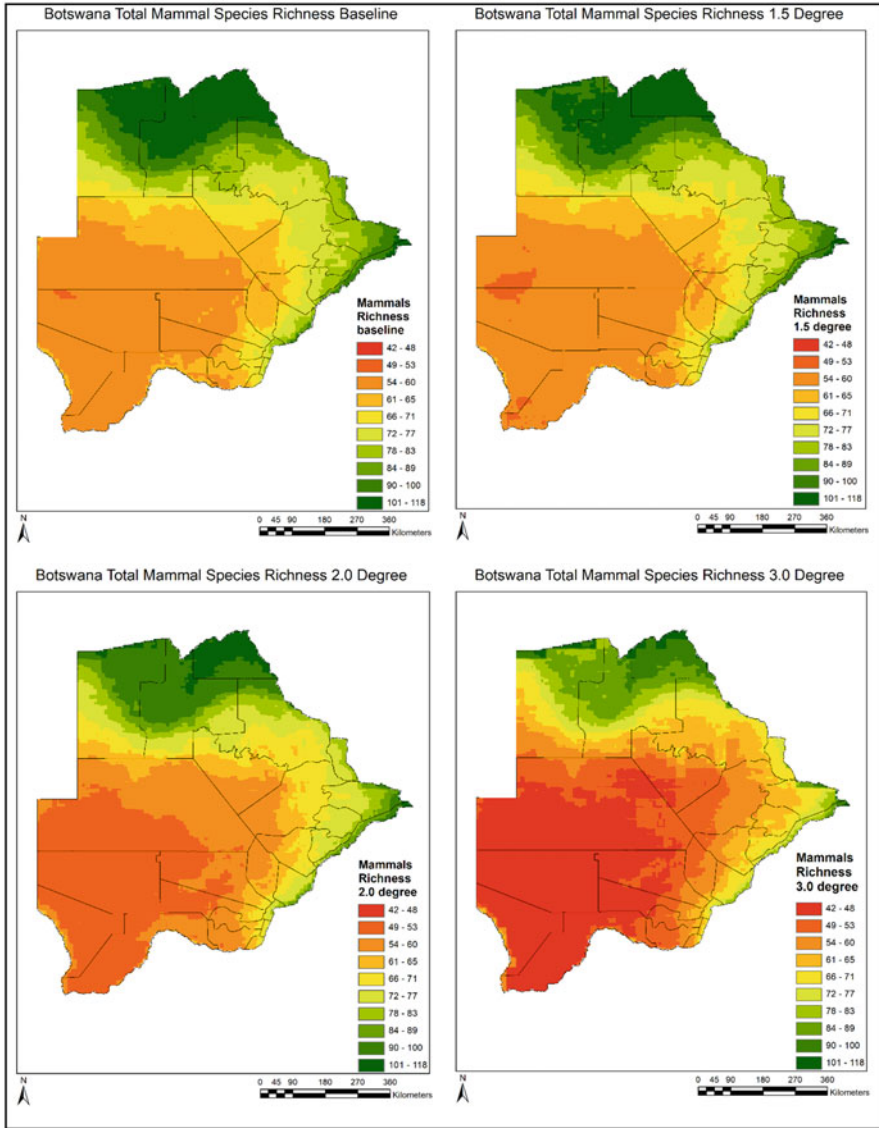


**Fig. 10** Changes projected for net primary production (NPP) under the three tipping point scenarios of 1.5 °C, 2 °C, and 3 °C, from baseline (average of 2000–2016). (Source: authors)

will be required as the pace of climate-induced changes mirror those of society. The following needs have been identified:

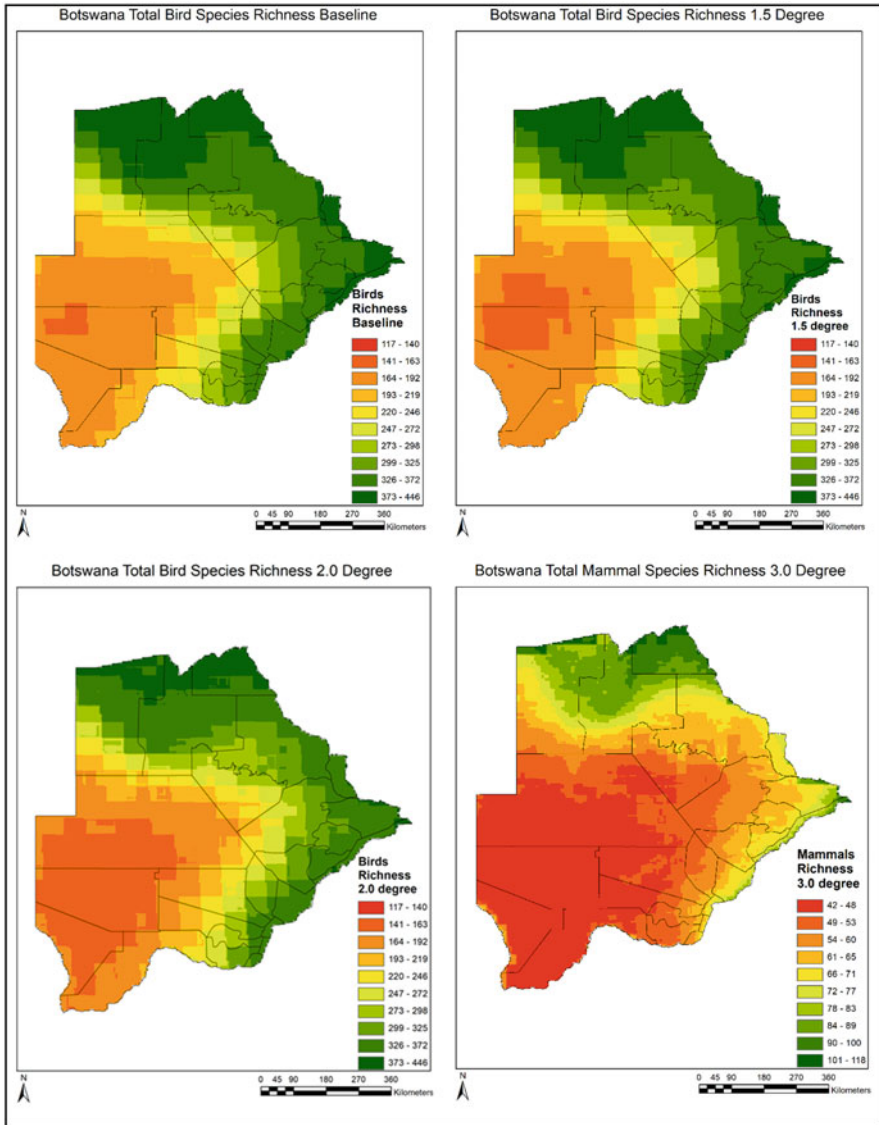
- (1) more specific, operational examples of adaptation principles that are consistent with unavoidable uncertainty about the future;
- (2) a practical adaptation planning process to guide the selection and integration of recommendations into existing policies and programs; and,
- (3) greater integration of social science into an endeavor that, although dominated by ecology, increasingly recommends extension beyond reserves and into human-occupied landscapes. (Heller and Zavaleta 2009: 14)





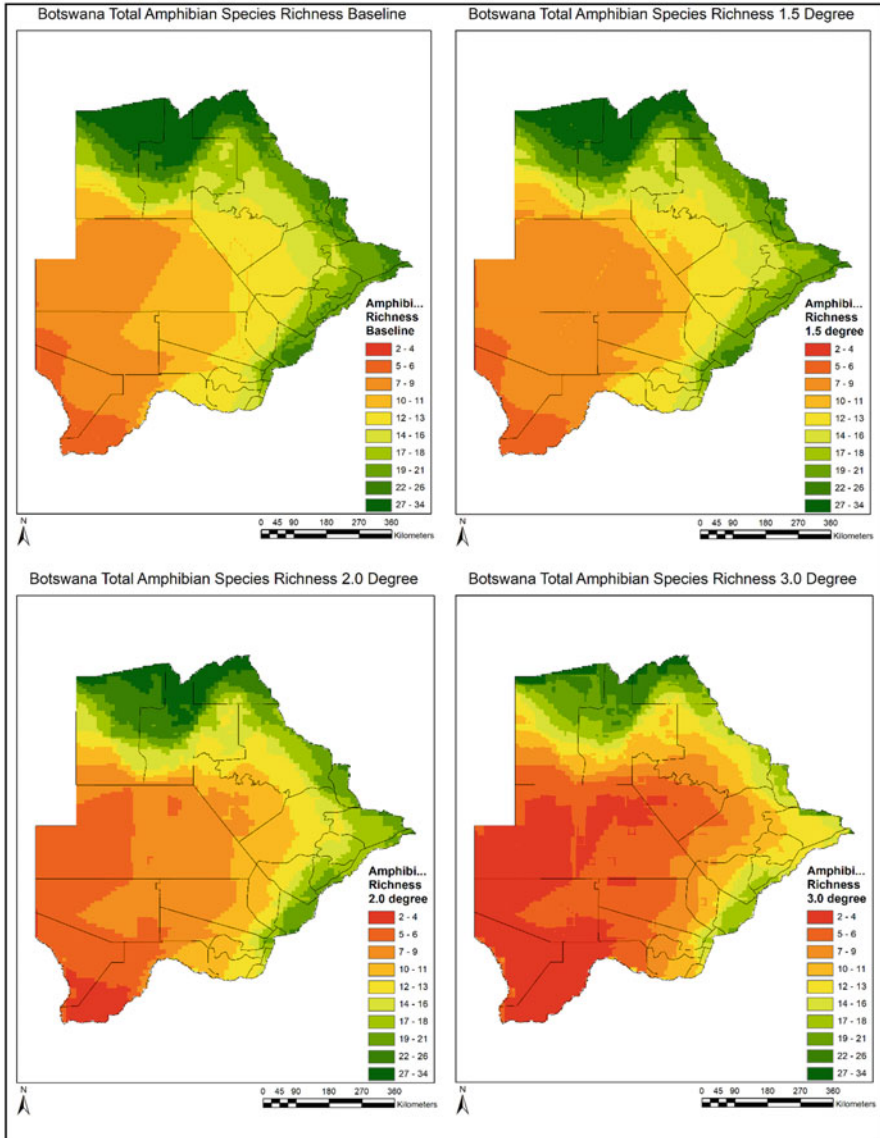
**Fig. 11** Changes projected for mammalian species richness under the three tipping point scenarios of 1.5 °C, 2 °C, and 3 °C, from baseline. (Source: authors)

The Paris Agreement is deemed to be beneficial to the cause of species biodiversity conservation as it represents a template for a GDN by setting global targets, an evolving model for financial support, and recognizes the values obtained from bottom-up efforts. Nearly all nations have signed the agreement. Climate scientists have arrived at a single numerical target for maintaining Earth’s atmosphere at safe



**Fig. 12** Changes projected for bird species richness under the three tipping point scenarios of 1.5 °C, 2 °C, and 3 °C, from baseline (note: data source available is at a different resolution than mammalian and amphibian sources, hence the different map smoothness). (Source: authors)

limits (1.5 °C); however, biodiversity scientists work with multiple targets to conserve the rest of life on the planet given the diversity of life and ecosystems and range of resilience. The challenge clearly shown in the case of biodiversity in Botswana is the interconnectedness of the nation with the southern African region



**Fig. 13** Changes projected for amphibian species richness under the three tipping point scenarios of 1.5 °C, 2 °C, and 3 °C, from baseline. (Source: authors)

and the faster than global average rise in temperatures. The international climate science goal of limiting global temperatures to 1.5 °C by 2100 is not relevant for places such as Botswana that could reach that average rise in temperature as early as 2028. The GDN has expressed its own target like the Paris Agreement: protect at least half of Earth’s biodiversity by 2050 and ensure that these areas are connected

**Table 4** Biodiversity sector tipping point analysis summary table

Impact factors	Slow processes	Variabilities	Extremes	Potential tipping points
Earth systems (climate change): Threshold risks	Biodiversity decrease vegetation primary production, land degradation, access to water, heat stress, diseases, tourism and agriculture land pressure, conflict	International variability increase, death rate increase, diseases, poaching	Extreme drought and diseases (foot and mouth) events Low water flows in Okavango Delta Wildlife movements/ encroachments to cropping areas	Continuous drought years could cause the wildlife high death rate and migration
Earth systems (climate change): Potential adaptation options	Recover and reserve natural habitats for natural earth systems	Provide alternative areas/substantial buffer zones for ecosystem change and succession	System integrity enhancement to support biodiversity resilience at times of climatic stress	Species migration pattern shifts Species decline and extinction Increased human/ biodiversity conflict
Social systems: Threshold risks	Tourism sector dependency, livestock number increase, rural labor force, and food relationship	Tourism natural conservation and human conflicts	Wildlife decrease during an extreme drought event	Dramatic changes in tourist sector behavior Loss of economic tourism opportunity without changes in location and interaction with species
Social systems: Potential adaptation options	Tourists and local people education and behavior regulation	Natural and human relationship education and behavior regulation	Reduce human impacts, support system natural recovery where is possible	Biodiversity and tourism sector in collaboration with other ISEET for systematic analysis and uplift social system support

(continued)

**Table 4** (continued)

Impact factors	Slow processes	Variabilities	Extremes	Potential tipping points
Institutional system: Threshold risks	Deficiency and out of date in biodiversity protection legislation and policy, land-use and planning legislation and policy	Government policy and institutional implementation capacity	Institutional dramatic changes	Policy failure
Institutional system: Potential adaptation options	Balanced policy and regulation and implementation capacity for biodiversity protection and tourism development	Policy and regulations support the resiliency of the biodiversity conservation that allows natural system recovery	Reinforce and stabilize institutional system, prepared for emergencies	Work together with closely linked ISEET systems, to build the robust institutions for biodiversity conservation and tourism
Economic systems: Threshold risks	Tourism sector over development Irrational land-use and agriculture development	International tourism market variations. Changed habitats and protected area systems too rigid for continuous protection of biodiversity as biomes shift	Market collapse, financial crisis	International financial crisis Tourist air travel depressed by GHG accounting and social pressure to reduce flying
Economic systems: Potential adaptation options	Financial regulation for overdevelopment and land development	Economic measures for sustainable tourism and biodiversity protection subsidies and compensation incentives	Tourism sector support and alternative work development	Overarching economic and financial arrangement for biodiversity and tourism, in coordination with ISEET systems

(continued)

**Table 4** (continued)

Impact factors	Slow processes	Variabilities	Extremes	Potential tipping points
Technological systems: Threshold risks	Wildlife and biodiversity conservation technology improvement Human intervention at a large scale to enhance biodiversity management regimes	Technology insufficiency Maladaptation in the management of biodiversity and conservation	Technology failure Species collapse from linked with wider environmental collapse from extreme heat and drop in net primary production	Huge biodiversity loss by technological system failure Disease outbreak and biome changes lead to mass extinction events and loss of keystone species
Technological systems: Potential adaptation options	Sustainable knowledge and technology applications development and introduction for biodiversity and tourism	Development and introduction of the knowledge and technologies for resilient biodiversity and tourism sectors	Technology improvement and backup mechanisms	Technology innovation and knowledge gaining for ISEET system stabilization

(Dinerstein et al. 2019). Over time the role of intact, diverse systems has been repeatedly demonstrated, and they are integral to carbon storage and hence the link to the Paris Agreement. For Botswana, intactness and linkages regionally will become increasingly relevant and urgent given the accelerating pace of temperature and other changes facing the country, which are well ahead of the global trends (Table 4).

## Summary and Conclusion

The implications of climate change are a growing concern for biodiversity managers in Botswana. Even simple extrapolation of current trends in temperature makes clear that a warming climate can have negative impacts on many facets of Botswana's society and ecosystems. The sum of these troubling effects, although highly uncertain, motivates efforts to assess and manage potential climate change impacts.

Climate change may trigger major social transformations. As seen around the globe, both slow-onset climate change and extreme weather events can, for example, induce food and water insecurity. Subsequent riots, mass movements of people, and pressure on governance systems to respond to limit social anxiety and loss of national cohesion are being increasingly researched.

However, it is not a simple, one-to-one relationship. The relationship between climate and biodiversity and social change is not easy to identify. The scale of climate change that can induce significant and consequential change and related calls

to action, including social transformations, may be minor or major. Often it is built-in resiliency of Institutional-Socio-Economic-Ecological-Technological Systems (ISEETS) that determines if a drought, flood, fire, epidemic disease, or another extreme event will trigger a societal response.

Climate change experts such as Tim Lenton pioneered the use of the term tipping points to refer to “abrupt and irreversible changes in the climate system.” The concept has been taken further than climate knowledge to further our understanding of the consequences of climate change. What are often overlooked in climate change research are the social determinants of changes, for example, inequities in determining the social impacts of climate change. Also ignored are perceptions and (mis) representations of change in whatever form that might be, as well as governance systems and institutions, solidarity networks, and cultural values, and underlying technological condition and opportunities in their evaluation of the future social impacts of climate change.

The experience of those interested in biodiversity in Botswana forms a recent historical example of how ecological tipping points are identified and sometimes managed historically ineffectively but with increased local and specific cultural and environmental awareness, more effectively. What are, therefore, more challenging to determine are the social tipping points that would potentially lead to more accurate assessments of the future impacts of climate change. This then expands the thinking about climate change to more fully grasp the biological effects of a changing climate and our technological capacity to forecast them and respond more effectively.

News has emerged on the recognition of the cross-sectoral importance of a more resilient Okavango ecological system which is encouraging. The signing in 2019 of the three-country pact to work, titled “Transboundary cooperation for protecting the Cubango-Okavango River Basin and improving the integrity of the Okavango Delta World Heritage,” properly championing an integrated approach to the entire river basin management is an important step forward (Kari and Kaboza 2019). The actors and agents involved and their perspectives represent an ISEET-like approach. The follow-up activities of implementation of defining activities and their monitoring and evaluation will be critical. Time is running out as climate change and its impacts accelerate across Southern Africa.

---

## References

- Alexander J, Chase J, Newman N, Porter A, Roessner JD (2012) Emergence as a conceptual framework for understanding scientific and technological progress. In: 2012 Proceedings of PICMET'2: technology management for emerging technologies, pp 1286–1292
- Anderson RL, Foster DR, Motzkin G (2003) Integrating lateral expansion into models of peatland development in temperate New England. *J Ecol* 91(1):68–76
- Andrews P, O'Brien EM (2000) Climate, vegetation, and predictable gradients in mammal species richness in southern Africa. *J Zool* 251(2):205–231
- Asayehegn K, Iglesias A, Triomphe B, Pédelahore P, Temple L (2017) The role of systems of innovation in adapting to climate change: the case of the Kenyan coffee and dairy sectors. *J Innov Econ Manag* 3:127–149
- Baer HA, Singer M (2018) *The anthropology of climate change: an integrated critical perspective*. Routledge, London

- Biggs R, Simons H, Bakkenes M, Scholes RJ, Eickhout B, van Vuuren D, Alkemade R (2008) Scenarios of biodiversity loss in southern Africa in the 21st century. *Glob Environ Chang* 18 (2):296–309
- Ceccarelli A, Zoppi T, Vasenev A, Mori M, Ionita D, Montoya L, Bondavalli A (2019) Threat analysis in systems-of-systems: an emergence-oriented approach. *ACM Trans Cyber Phys Syst* 3(2):18
- Christiansen L, Olhoff A, Trærup S (eds) (2011) *Technologies for adaptation: perspectives and practical experiences*. UNEP Risø Centre, Roskilde
- Cole DH, Epstein G, McGinnis MD (2014) *Toward a new institutional analysis of social-ecological systems (NIASES): combining Elinor Ostrom's IAD and SES frameworks*. Indiana legal studies research paper, no. 299; Indiana University, Bloomington School of Public and Environmental Affairs research paper, no. 2490999. Indiana University, Bloomington School of Public & Environmental Affairs, Bloomington
- Dai L, Vorselen D, Korolev KS, Gore J (2012) Generic indicators for loss of resilience before a tipping point leading to population collapse. *Science* 336(6085):1175–1177
- Dinerstein E, Vynne C, Sala E, Joshi AR, Fernando S, Lovejoy TE, . . . Burgess ND (2019) A global deal for nature: guiding principles, milestones, and targets. *Sci Adv* 5(4):eaaw2869
- Du K, O'Connor A (2019) Examining economic complexity as a holistic innovation system effect. *Small Bus Econ*. <https://doi.org/10.1007/s11187-019-00215-z>
- Gerten D et al (2013) Asynchronous exposure to global warming: freshwater resources and terrestrial ecosystems. *Environ Res Lett* 8:034032
- Goldstein JA (2018) Emergence and radical novelty: from theory to methods. In: *Handbook of research methods in complexity science*. Edward Elgar Publishing, Cheltenham
- Gregory P, Stuart R (2013) *The global economy and its economic systems*. South-Western Cengage Learning, Boton, MA
- Halley JD, Winkler DA (2008) Classification of emergence and its relation to self-organisation. *Complexity* 13(5):10–15
- Heller NE, Zavaleta ES (2009) Biodiversity management in the face of climate change: a review of 22 years of recommendations. *Biol Conserv* 142(1):14–32
- Hope M, McCloskey J, Hunt D, Crowley D, Bhloscaidh NM (2018) Innovation pathways to adaptation for humanitarian and development goals: a case study of aftershock forecasting for disaster risk management. *J Extreme Events* 5(02n03):1850010
- IPBES (2018) *The IPBES regional assessment report on biodiversity and ecosystem services for Africa* (eds: Archer E, Dziba L, Mulongoy KJ, Maoela MA, Walters M). Secretariat of the Intergovernmental Science-Policy Platform on Biodiversity and Ecosystem Services, Bonn. 492 pages. <https://doi.org/10.5281/zenodo.3236178>
- IUCN (2008) Table 5: Threatened species in each country (Totals by Taxonomic Group)
- IUCN (2019) Table 5: Threatened species in each country (Totals by Taxonomic Group)
- Jones A (2017) *Tourism in Botswana: tourist destinations in Botswana – wildlife*. Amazon E-Book
- Kari S, Kaboza Y (2019) Proceedings of the expert meeting “Transboundary co-operation for protecting the Cubango-Okavango River Basin and improving the integrity of the Okavango Delta World Heritage property”, Maun, 3–4 June 2019. 36 pgs
- Keys PW et al (2019) Anthropocene risk. *Nat Sustain* 2:667–673
- Leadley P, Pereira HM, Alkemade R, Fernandez-Manjarrés JF, Proença V, Scharlemann JP, Walpole MJ (2010) *Biodiversity scenarios: projections of 21st century change in biodiversity and associated ecosystem services*. Secretariat of the Convention on Biological Diversity, Montreal. Technical Series no. 50, 132 pages
- Lenton TM et al (2008) Tipping elements in the Earth's climate system. *PNAS* 105:1786–1793
- Lenton TM, Livina VN, Dakos V, Van Nes EH, Scheffer M (2012) Early warning of climate tipping points from critical slowing down: comparing methods to improve robustness. *Philos Trans R Soc A Math Phys Eng Sci* 370(1662):1185–1204
- Lichtenstein BB (2014) *Generative emergence: a new discipline of organisational, entrepreneurial and social innovation*. OUP US, New York



- Liu Z, Otto-Bliesner BL, He F, Brady EC, Tomas R, Clark PU, . . . Erickson D (2009) Transient simulation of last deglaciation with a new mechanism for Bølling-Allerød warming. *Science* 325(5938):310–314
- Lucas K, Renn O, Jaeger C, Yang S (2018) Systemic risks: a homomorphic approach on the basis of complexity science. *Int J Disaster Risk Sci* 9(3):292–305
- MacPherson AJ, Gillson L, Hoffman MT (2019) Between-and within-biome resistance and resilience at the fynbos-forest ecotone, South Africa. *The Holocene* 29(11):1801–1816
- McCarthy NA (2003) Demand for rainfall-index based insurance: a case study from Morocco, vol 106. International Food Policy Research Institute, Washington, DC
- McCord PF, Dell'Angelo J, Bladwin E, Evans T (2017) Polycentric transformation in Kenyan water governance: a dynamic analysis of institutional and social-ecological change: polycentric transformation in Kenyan water governance. *Policy Stud J* 45(4):633–658
- Midgley GF, Thuiller W (2011) Potential responses of terrestrial biodiversity in Southern Africa to anthropogenic climate change. *Reg Environ Chang* 11(1):127–135
- Newbold T (2018) Future effects of climate and land-use change on terrestrial vertebrate community diversity under different scenarios. *Proc R Soc B Biol Sci* 285(1881):20180792
- Oliver TH, Marshall HH, Morecroft MD, Brereton T, Prudhomme C, Huntingford C (2015) Interacting effects of climate change and habitat fragmentation on drought-sensitive butterflies. *Nat Clim Chang* 5(10):941–945
- Polhill JG, Filatova T, Schlüter M, Voinov A (2016) Modelling systemic change in coupled socio-environmental systems. *Environ Model Softw* 75:318–332
- Porter AL, Garner J, Carley SF, Newman NC (2019) Emergence scoring to identify frontier R&D topics and key players. *Technol Forecast Soc Chang* 146:628–643
- Roundy PT, Bradshaw M, Brockman BK (2018) The emergence of entrepreneurial ecosystems: a complex adaptive systems approach. *J Bus Res* 86:1–10
- Ryan AJ (2007) Emergence is coupled to scope, not level. *Complexity* 13(2):67–77
- Saarinen J, Hambira WL, Athlopheng J, Manwa H (2012) Tourism industry reaction to climate change in Kgalagadi South District, Botswana. *Dev South Afr* 29(2):273–285
- Schot J, Kanger L (2018) Deep transitions: emergence, acceleration, stabilisation and directionality. *Res Policy* 47(6):1045–1059
- Steffen W, Rockström J, Richardson K, Lenton TM, Folke C, Liverman D, . . . Donges JF (2018) Trajectories of the Earth System in the Anthropocene. *Proc Natl Acad Sci* 115(33):8252–8259
- Sterner T, Barbier EB, Robinson A (2019) Policy design for the Anthropocene. *Nat Sustain* 2:14–21
- Tàbara JD, Frantzeskaki N, Hölscher K, Pedde S, Kok K, Lamperti F, Berry P (2018) Positive tipping points in a rapidly warming world. *Curr Opin Environ Sustain* 31:120–129
- United Nations Framework Convention on Climate Change (UNFCCC) (2005) Report on the seminar on the development and transfer of technologies for adaptation to climate change: note by the Secretariat. FCCC/SBSTA/2005/8
- van der Vleuten E (2019) Radical change and deep transitions: lessons from Europe's infrastructure transition 1815–2015. *Environ Innov Soc Trans* 32:22–32
- Waisman H, Bataille C, Winkler H, Jotzo F, Shukla P, Colombier M, . . . La Rovere E (2019) A pathway design framework for national low greenhouse gas emission development strategies. *Nat Clim Chang* 9(4):261
- Walby S (2007) Complexity theory, systems theory, and multiple intersecting social inequalities. *Philos Soc Sci* 37(4):449–470
- Wilson F, Moser G, Fallon D, Farrell CA, Müller C, Wilson D (2019) Rewetting degraded peatlands for climate and biodiversity benefits: results from two raised bogs. *Ecol Eng* 127:547–560
- Winterbach HE, Winterbach CW, Somers MJ (2014) Landscape suitability in Botswana for the conservation of its six large African carnivores. *PLoS One* 9(6):e100202. <https://doi.org/10.1371/journal.pone.0100202>
- Winterbach CW, Whitesell C, Somers MJ (2015) Wildlife abundance and diversity as indicators of tourism potential in Northern Botswana. *PLoS One* 10(8):e0135595. <https://doi.org/10.1371/journal.pone.0135595>

**Open Access** This chapter is licensed under the terms of the Creative Commons Attribution 4.0 International License (<http://creativecommons.org/licenses/by/4.0/>), which permits use, sharing, adaptation, distribution and reproduction in any medium or format, as long as you give appropriate credit to the original author(s) and the source, provide a link to the Creative Commons license and indicate if changes were made.

The images or other third party material in this chapter are included in the chapter's Creative Commons license, unless indicated otherwise in a credit line to the material. If material is not included in the chapter's Creative Commons license and your intended use is not permitted by statutory regulation or exceeds the permitted use, you will need to obtain permission directly from the copyright holder.





# Access to Water Resources and Household Vulnerability to Malaria in the Okavango Delta, Botswana

# 60

M. R. Motsholapheko and B. N. Ngwenya

## Contents

Introduction .....	1228
Conceptual Framework .....	1229
Okavango Delta: Environmental and Socioeconomic Context .....	1232
Research Approach and Data Collection .....	1234
Participatory Rural Appraisal (PRA) Workshop .....	1234
Household Survey .....	1235
Access to Water Resources in Shakawe and Ngarange .....	1236
Household Vulnerability to Malaria in Shakawe and Ngarange .....	1238
Discussion and Conclusion .....	1243
References .....	1244

## Abstract

Malaria is a persistent health risk for most rural communities in tropical wetlands of developing countries, particularly in the advent of climate change. This chapter assesses household access to water resources, livelihood assets, and vulnerability to malaria in the Okavango Delta of north-western Botswana. Data were obtained from a cross-sectional survey of 355 households, key informant interviews, PRA-

This chapter was previously published non-open access with exclusive rights reserved by the Publisher. It has been changed retrospectively to open access under a CC BY 4.0 license and the copyright holder is “The Author(s)”. For further details, please see the license information at the end of the chapter.

M. R. Motsholapheko (✉)

Water Resources Management Program, Okavango Research Institute, University of Botswana, Maun, Botswana

e-mail: [rmoseki@ub.ac.bw](mailto:rmoseki@ub.ac.bw)

B. N. Ngwenya

Ecosystems Services Program, Okavango Research Institute, University of Botswana, Maun, Botswana

e-mail: [bntombi@ub.ac.bw](mailto:bntombi@ub.ac.bw)

© The Author(s) 2021

W. Leal Filho et al. (eds.), *African Handbook of Climate Change Adaptation*,  
[https://doi.org/10.1007/978-3-030-45106-6\\_165](https://doi.org/10.1007/978-3-030-45106-6_165)

1227

based focus group discussions (FDGs), interviews with experts in various related fields, PRA workshop participant interviews, and literature review. There was high access to natural capital, and most households engaged in nature-based livelihood activities. Access to resources determined type of livelihood activities that households engaged in. However, there was no association between household exposure and/or susceptibility, and type of livelihood activities pursued by households. Household vulnerability to malaria was higher in remote and rural locations than in urban neighborhoods. Malaria prevention and vulnerability aversion programs need to be coupled with improvements in housing and well-being in the Okavango Delta and similar wetlands.

---

**Keywords**

Livelihoods · Malaria · Vulnerability · Wetlands

---

**Introduction**

In developing countries, access to natural resources largely determines human livelihoods and general well-being of households in many rural communities (Rebelo et al. 2010). Due to lack of access to various forms of capital including financial, physical, human, and social capital, and because of general poverty the dependence on natural resources has been increasing in wetland communities around the world. This is because wetlands act as sources of various forms of ecosystem services that support livelihoods. At the same time, wetlands provide suitable habitats for disease-carrying organisms and therefore remain vector- and water-borne diseases endemic areas. Some vector-borne diseases such as malaria account for millions of human morbidity and deaths annually. For instance, the World Health Organization (WHO) reported that in 2018 malaria accounted for 228 million morbidity cases and 405,000 deaths globally, 94% of which were in Africa (WHO 2019). Due to climate variability and change, the prevalence and virulence of vector-borne diseases (VBDs), including malaria, may increase (IPCC 2007). The challenges associated with malaria outbreaks include deaths of breadwinners in mostly poor households, which largely depend on the labor of their able-bodied members. Given that such mortalities often result in increased suffering of mostly women, children (WHO 2019), and other vulnerable groups, the fight against malaria requires concerted efforts on the part of governments, NGOs, communities, and other stakeholders to enhance access to prevention and treatment. Prevalence of malaria in tropical and subtropical regions including Africa, continues to overwhelm existing measures for prevention and treatment. This leads scientists and policymakers to assess existing forms of prevention and treatment with a view to developing effective means for combating malaria.

Various approaches have been adopted particularly in the prevention and treatment of malaria including (a) distribution of free insecticide-treated mosquito nets (ITNs) in rural communities, (b) use of preventive antimalarial medicines,

(c) interior and exterior spraying, (d) awareness creation, and (e) educational campaigns. Most of these efforts have been supported by governments, NGOs, and global organizations including the World Health Organization. As a result, there is a general decline in the prevalence of malaria in developing countries. In some countries, where malaria prevalence had been recorded and often led to deaths, malaria has been successfully eradicated.

Botswana is one of the 21 countries which were identified by the WHO for malaria elimination by 2020 (WHO 2019). Botswana is also among eight southern African countries which formed the Elimination-8 partnership aimed at eradicating cross-border malaria transmission by 2030 through collaborations and synchronization of policies and initiatives. At the national level, a rapid notification and response strategy was developed to eliminate malaria in hotspot areas, including the Ngamiland District in the Okavango Delta in Botswana (Chihanga et al. 2016).

Despite all these efforts, malaria remains pervasive in wetlands of developing countries, including Botswana, particularly among poor households. This calls for additional efforts to determine the general vulnerability of communities to malaria to improve general knowledge on factors that contribute to its persistence. This chapter is aimed at improving knowledge on household vulnerability to malaria in the Okavango Delta and similar areas around the world. Specifically, the chapter assesses (a) household access to water resources and (b) household vulnerability to malaria in Shakawe and Ngarange villages and the surrounding areas. The chapter is arranged as follows: the next section discusses the conceptual framework used, followed by environmental and socioeconomic context, research approach and data collection, the results on access to capital and household vulnerability, and finally, the section on discussion, conclusion, and implications for malaria policies in the Okavango Delta and other wetlands in similar socioeconomic and environmental conditions.

---

## Conceptual Framework

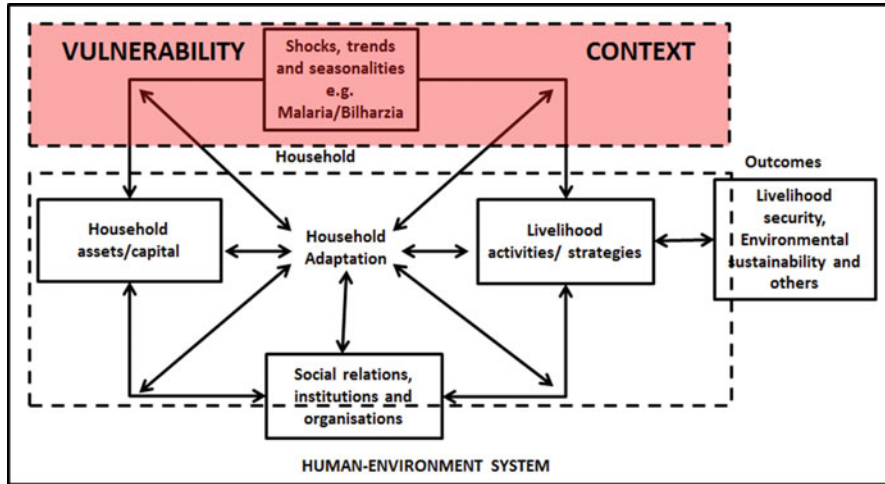
This research was informed by the sustainable livelihood framework supplemented by the socio-ecological framework. These frameworks were selected for their wide use in microeconomic analyses on access to resources, rural livelihoods, and household vulnerability to shocks in developing countries. The frameworks differ in their approach to the household vulnerability context; the former views livelihood shocks as exogenous factors that are beyond household control, whereas the latter posits that shocks and household livelihoods are interlinked within the broad human–environment interactions (Berkes and Folke 1998; Ellis 2000). Both frameworks were influenced by the changing view on vulnerability as not just the biophysical nature of the shock but the state of the affected social unit as well (Wisner et al. 2004).

The sustainable livelihood framework provides an understanding of the broad concept of a livelihood, particularly the vulnerability context within a livelihood is constructed. In the sustainable livelihood framework, a livelihood can be defined as

“...comprising of assets (natural, physical, human, financial, and social capital), the activities, and the access to these (mediated by institutions and social relations) that together determine the living gained by the individual or household” Ellis (2000, p. 30). The sustainable livelihood framework has some limitations because it does not cater for changes over time (Ellis 2000). It is nonhistoric because it takes current household access to resources as given, without looking at the origins and possible causes of current access conditions (Small 2007). Furthermore, it neither provides for tracing historical factors leading to current institutional structure, nor for understanding the nature of interactions between actors brought together by various interests and complying to set rules, norms, and practices (O’Laughlin 2002). For instance, it does not clearly show the role of the private sector as part of the organizations that mediate access to forms of capital. Furthermore, it does not provide adequate guidance on the analysis of institutions and the behavior of actors involved.

Another observation is that the vulnerability context in the sustainable livelihood framework does not consider the full context of shocks, trends, and seasonality, partly because it does not clearly show the position of the household itself. Although it considers both the negative and positive aspects of these processes, it does not clearly show how negative livelihood outcomes can exacerbate the impacts of shocks in the vulnerability context. This may be because it construes shocks as exogenous factors and therefore beyond household control (Ellis 2000). The sustainable livelihood framework is an integrating analytical tool which was never intended to be used in isolation (Farrington et al. 1999). The sustainable livelihood framework was supplemented with the socio-ecological framework to overcome some of its limitations. The socio-ecological framework was useful in locating the household construction of a livelihood within the broad human–environment interactions in which it occurs. In other words, it helped clarify the broad livelihood vulnerability context in the Okavango Delta. The socio-ecological complex or framework emanated from classical human ecology in the 1930s (Berkes and Folke 1998). It was influenced by the concept of resilience which has now become important for understanding complex relationships between human and other ecological systems (Folke 2001). The socio-ecological framework has been modified and used for analyzing human–environment interactions in developing countries and providing the basis for some contemporary vulnerability frameworks (Arntzen 1989; Adger 2006). This framework analyses rural development in terms of clusters of elements and interactions among clusters, which finally lead to a sustainable society or community (Arntzen 1989; Berkes and Folke 1998). It distinguishes four elements that characterize the socio-ecological linkages and interactions. These are population, organization, the environment, and technology at the micro-scale, with influencing factors at the macro-scales (regional, national, and global) (Arntzen 1989; Berkes and Folke 1998).

Understood in the context of this framework, the household as a human construct (illustrated in Fig. 1 below), and the livelihood as a subset of the household system, fall within the broad human–environment system.



**Fig. 1** Sustainable livelihood framework. (Source: Adapted from Ellis (2000, p. 30) with insights from Berkes and Folke (1998, p. 15))

Therefore, the impacts of a shock such as malaria, on a household livelihood and the household responses are part of the interface between the human and environment subsystems. In other words, it is acknowledged that livelihood shocks such as malaria are exogenous to a household because they fall beyond household control as posited by Ellis (2000). However, the effect of their impacts falls within household control depending on household exposure, susceptibility, and capacity to adapt. Therefore, such effects are part of the household vulnerability complex made up of the social (human) and biophysical (or ecological) aspects (Marshall et al. 2009). In the case of malaria endemicity in the Okavango Delta, household adaptation which is the inverse of vulnerability can therefore be viewed as the process and actions within a livelihood system occurring or being undertaken to positively influence or be influenced by livelihood security and environmental sustainability. This position is informed by the view that a livelihood is sustainable if it can adapt, be resilient, and therefore less vulnerable to shocks while not degrading the natural resource base (Scoones 1998).

Household adaptation to a livelihood shock such as malaria may occur at various dynamic levels influencing or being influenced by livelihood security and or environmental sustainability. It may also reduce the impacts of a shock on both livelihood assets and household livelihood activities, as well as the impacts of the institutions, social relations, and organizations, which modify or mediate access to household assets. Household actions to reduce vulnerability to malaria may also affect the setting up of livelihood activities with influence on the type of activity and location within which they may be undertaken. Of course, in case of maladaptation which has a positive effect in increasing vulnerability, the influence will be negative, leading to livelihood insecurity and environmental degradation. Of interest in this

chapter is the household access to assets in the process of constructing livelihood activities and how such access exposes and makes households susceptible to malaria as a health risk. The chapter focuses on the vulnerability context as illustrated in Fig. 1 above.

---

## Okavango Delta: Environmental and Socioeconomic Context

The Okavango Delta is an alluvial fan and a vast wetland well-renowned for its biodiversity, species richness, and prominence as a Ramsar Site, and 1000th UNESCO World Heritage Site in north-western Botswana. Due to its richness in flora and fauna, the Okavango Delta enhances dynamic livelihood systems within a semiarid environment of the southern African Kalahari plains. The Okavango Delta and related floodplains, at an altitude of 900 m above sea-level, within a low-physiographic zone given the generally flat terrain, and daily temperatures ranging from 12 °C to 40 °C provide a suitable habitat for the anopheles mosquito (*Anopheles arabiensis*). Rural communities found in many settlements around the Delta fringes as they depend on the natural resources in the form of flora such as papyrus, riverine reeds, grasses, and others, as well as faunal species including fish, birds, and small game.

The specific research sites were the villages of Shakawe and Ngarange in the Okavango sub-District of Ngamiland District. Ngamiland West, a Ministry of Health designated area which largely covers the Okavango sub-District, is among the poorest regions in the country with 47.3% of people below the poverty datum line compared to the national figure of 20.7% (Statistics Botswana 2011). Ngamiland West is a malaria-endemic area due to the high persistence of this disease in many of its villages. HIV/AIDS prevalence in the Ngamiland District is also high (18%), compared to the national average of 17.6% (Central Statistics Office 2009) (Fig. 2).

Shakawe and Ngarange villages are in an area commonly referred to as the panhandle, which is made up of the Okavango River as it enters Botswana from the Kavango Region of Namibia. Shakawe village has a population of 6693 people and Ngarange has 998 people. The population structures of these two villages (Fig. 3) depict a wide base in the young age groups compared to advanced age groups; the patterns that are typical of population structures found in developing countries.

However, there appears to be an anomaly in that the population pyramids in these villages have a narrowed base particularly in the infant cohorts and under-five age group, which is indicative of low fertility and possibly high mortality in these age groups. This is a logical observation in that due to high prevalence of HIV/AIDS, women may tend to postpone their engagement in sexual activity, or totally abstain from sex to avoid repeat infections and/or opt for effective birth prevention methods (Lewis et al. 2004). Due to illness and the impacts of opportunistic diseases, HIV/



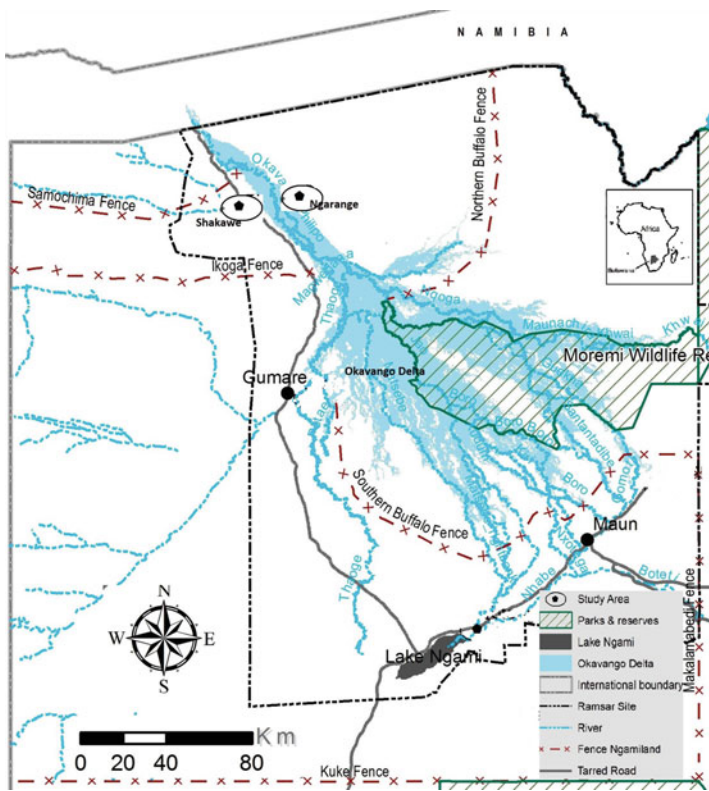


Fig. 2 Map showing the Okavango Delta and the study villages. (Source: ORI GIS Lab)

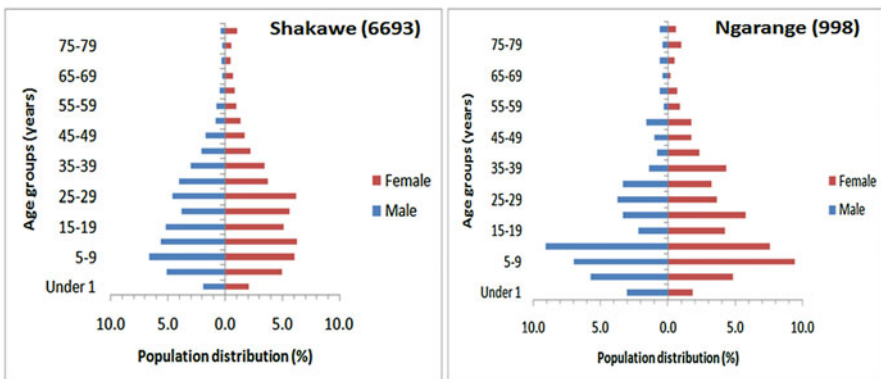


Fig. 3 Population structure in Shakawe and Ngarange villages

AIDS also has adverse effects on fertility (Ross et al. 1999). Infant and under-five mortality is generally higher in communities with high HIV/AIDS prevalence than in those with low prevalence and this may have been contributed to the narrow pyramid base in these two villages. From the foregoing, households in Shakawe and surrounding villages including Ngarange may be vulnerable to other diseases including malaria.

Shakawe has been identified as a malaria hotspot in Botswana mainly due to the high number of confirmed cases in this village. Ngarange has been observed to have low confirmed cases compared to other settlements in the same area. These two villages were selected to understand this apparent contrast and general dynamics surrounding household vulnerability to malaria in the Okavango Panhandle and the Okavango Delta in general.

---

## Research Approach and Data Collection

A convergent parallel mixed-method approach was adopted; it involved the concurrent use of qualitative and quantitative methods of data collection and analysis. This approach made it possible to exhaustively obtain information from the various methods used and substantively confirm outcomes through triangulation. It was also noninterventional given that no further action was taken in treating those infected with malaria; affected individuals received treatment from local health clinics in the respective villages.

Secondary data were obtained through desktop searches in the World Wide Web and from the review of published and unpublished sources including journal articles, global and regional health (and other) organizations' reports, and the national health policy and strategy documents. Primary data were obtained, (a) through a participatory rural appraisal (PRA) methodology which included key informant interviews and PRA-based focus group discussions, (b) through a household survey and informal discussions with community members, and (c) from interviews with various stakeholders including officers in local health clinics, the district office in Maun, the sub-District main office in Gumare, and from the Ministry of Health head office in Gaborone.

## Participatory Rural Appraisal (PRA) Workshop

A PRA workshop was held on June 25–27, 2014 in Shakawe with the aim to create project awareness, stakeholders' involvement, and participation in the project, and to collect baseline data on key areas that required further scientific enquiry. In the latter aim, the researchers were able to document community knowledge on livelihoods, the social, environmental, and climate change factors that influence household vulnerability to vector-borne diseases including malaria. Stakeholders including traditional leaders, traditional health practitioners, representatives of various village committees, modern medical practitioners, government health officers, and non-governmental organizations' (NGOs) representatives were invited to the workshop.

The criteria for selecting other members of the community included (a) being adult women and men above the age of 18 years, (b) having lived in the locality for 10 years or more, and (c) being knowledgeable on vector-borne diseases. A total of 40 people, 25 (63%) from Shakawe, and 15 (38%) from Ngarange were invited; the total consisted of 13 (32%) female and 27 (68%) male. Given the diversity of stakeholders and level of representation, the PRA workshop provided opportunities for interviews with the attendants individually, as key informants, discussants in focus group discussions, and as participants in a plenary.

## Household Survey

The household survey was undertaken following a stratified sampling of households. Information on malaria occurrence was first obtained from the local clinics in the villages of Shakawe and Ngarange. Using such information, village wards were identified and differentiated according to high, medium, and low number of malaria cases. Village wards were then randomly selected from the broad categories of high, medium, and low malaria cases. In Shakawe, a total of seven out of fourteen wards were selected. Although the same stratification criteria of high, medium, and low malaria cases were used in Ngarange, given the small size of the village, all wards were selected. After the selection of wards in both villages, all households in the selected wards were listed. From a list of households in all the selected wards, households were selected proportionate to size of ward. In Shakawe, a total of 877 households were listed in the seven wards, whereas in Ngarange 300 households were listed in the four wards, therefore some overall total of 1177 households were listed in these two villages. The sample size in the two villages was calculated at 95% confidence interval with margin of error of plus/minus five (+/-5). An overall sample of 355 households (266 in Shakawe and 89 in Ngarange) was selected in the two villages (Table 1).

**Table 1** Number of households listed and sampled in various wards of Shakawe and Ngarange villages

Village	Ward	Listed households ( <i>N</i> = 1177)	Sampled households ( <i>n</i> = 355)
Shakawe ( <i>n</i> = 266)	Mabudutsa	29	9
	Matomo	55	17
	Ukusi	83	25
	Ndumbakatadi	163	49
	Saoshoko	178	54
	Diseta	140	42
	Gauxa	229	70
Ngarange ( <i>n</i> = 89)	Modubana	103	30
	Newtown	48	14
	Mukumbe	107	33
	Sekandeko	42	12

A questionnaire comprising structured and semistructured questions were developed. It had sections on (a) household demographic and socioeconomic characteristics, (b) types of livelihood activities, (c) access to and ownership of assets or capital, (d) malaria prevention and coping strategies and other sociocultural variables. Data on household characteristics, livelihood types, and malaria prevention and coping strategies were captured through open- and close-ended questions. Data on access to capital were obtained through several proxy indicators. For example, access to financial capital was measured using questions on whether (or not) a household had access to cash, credit, and insurance, and access to physical capital was measured through questions on ownership of assets such the plowing equipment, vehicles, telecommunication equipment, and so on.

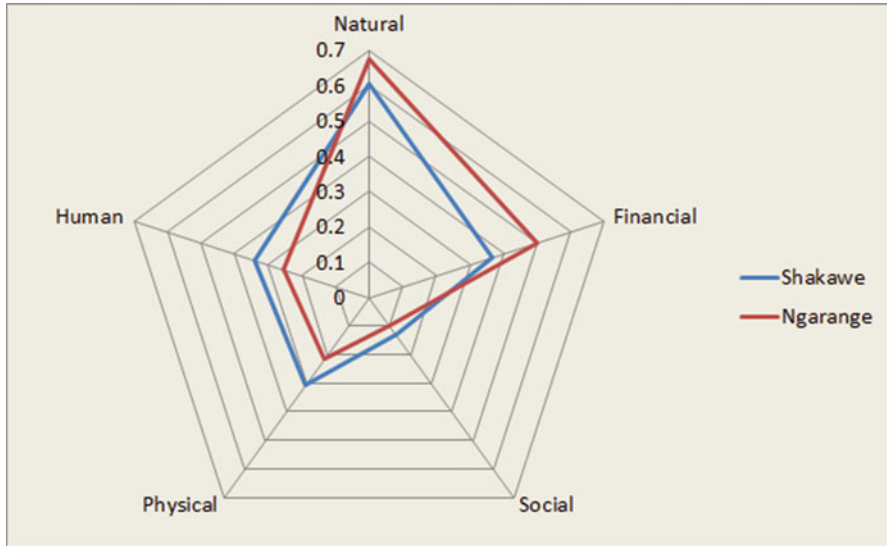
Various forms of capital were measured using different units; therefore, composite unitless indices similar to the UNDP's human development index were developed to consolidate the various measurement units. Data on household adaptive capacity, susceptibility, and exposure were also captured and transformed into unitless indices. Vulnerability was then calculated using a composite index, being a function of exposure less adaptive capacity, multiplied by susceptibility. Details of the techniques used are described in detail in Hahn et al. (2009), Motsholapheko et al. (2011), and UNDP (1990), so they will not be repeated in this chapter. The questionnaire was administered through face-to-face interviews with household heads, their spouses, and adult representatives. The survey data collection was undertaken in the period October 27 to November 6, 2015, in the two villages of Shakawe and Ngarange.

---

## Access to Water Resources in Shakawe and Ngarange

Results from the survey (Fig. 4) reflected generally similar patterns of access to capital in the two villages. Access to natural capital was higher than that of other capital types in both Ngarange and Shakawe. However, specific differences can be identified; households in Ngarange had slightly higher access to natural capital than those in Shakawe; the index values were 0.67 and 0.61, respectively. Worth noting is that access index values are all above 0.5 and edge toward the value of one which is the maximum. This result is not surprising given that Ngarange has a small population and the village is remotely located on the eastern side of the river which has vast floodplains than in the western escarpment where Shakawe is located. The proportions of households who stated that they had unimpeded access to land, water, forest, and aquatic resources were higher in Ngarange, ranging from 63% to 75%, compared to Shakawe where these proportions ranged from 56% to 72%. In wetlands, such as the Okavango Delta, rural communities depend on natural resources to make a living.

Ngarange households had slightly higher access to financial capital than their counterparts in Shakawe with index values of 0.5 and 0.36, respectively. This was a counter-intuitive result given that Shakawe, as the main commercial center in the area, is more urbanized than Ngarange. A further assessment of household characteristics and livelihood activities revealed that most households in Shakawe were



**Fig. 4** Household access to resources in Shakawe and Ngarange villages

*de jure* female-headed (57%) whereas male-headed households accounted for 33% and the rest were *de facto* female-headed at 10% (De jure female-headed households are those that are directly headed by females, whereas *de facto* female are those headed by females in the absence of the substantive male head (Motsholapheko et al. 2011).). Conversely, most households in Ngarange were male-headed (44%), the remaining being *de jure* (25%) and *de facto* (31%) female-headed. Interviews with experts on livelihoods and social development in the area revealed that although Shakawe is more urbanized than most settlements around it, the village could have experienced retarded development related to ownership of land. Large portions of undeveloped land in the village belong to a few individuals whose capacity to develop may either be limited or depends on self-interest and monopolistic tendencies. A further scrutiny of the above indices for Ngarange (0.5) and Shakawe (0.36) indicates a generally low access to financial capital in both villages, given that households have access values of up to half or less than the maximum value of one.

Access to physical, human, and social capital was higher in Shakawe than in Ngarange. Index values were 0.31 and 0.21 for physical capital, 0.34 and 0.25 for human capital, and 0.13 against 0.1 for social capital in Shakawe and Ngarange, respectively. A key observation here is that although Shakawe village households have a slight edge over those in Ngarange, all the above values are very low ranging from 0.26 to 0.36 which reveals very low access compared to a maximum value of one. In terms of ranking, access to natural capital would be the highest followed by financial, human, physical, and social capital in that order. Social capital was least accessed by households in both villages. Key informant interviews have revealed

that access to social capital in these villages was adversely affected by loss of culture, breakdown in family ties, individualism, and general lack of cooperation within the village community.

## Household Vulnerability to Malaria in Shakawe and Ngarange

Results from PRA-based key informant interviews (Table 2) revealed a general awareness among interviewees that malaria exposure was dominant among some social groups than others within their communities.

Most key informant interviewees (78%) stated that under-five children were the most exposed to malaria whereas safari operators were the least exposed, being stated by 35% of the interviewees. According to key informants, the top five most affected social groups were under-five children, primary school, commercial fishers, pregnant women, hook and line fishers, and river reed/grass harvesters. Commercial fishers and pregnant women were stated by an equal proportion of key informants at 52%. The various social groups stated above are linked to the types of livelihood activities they engage in, as well as their levels of possible susceptibility to malaria given their physical condition. For example, under-five children and pregnant women are known to be more susceptible to most diseases due to their physical condition (Bates et al. 2004).

Key informant interviewees also perceived that some livelihood activities such as commercial fishing and river grass harvesting were high-risk activities for malaria exposure; they were stated by 62.5% and 50% of the interviewees, respectively (Table 3). The top five livelihood activities stated by interviewees as likely to expose households and community members to malaria were commercial fishing, grass harvesting, reed harvesting, livestock herding, hook and line fishing, and arable farming.

**Table 2** Key informants' perceptions on social groups and vulnerability to malaria

Social group	Proportion of key informants % ( <i>n</i> = 40)	Top five social groups
Children <5 years	78	1. Children <5
Primary school children	58	2. Primary school children
Pregnant women	52	3. Commercial fishers and pregnant women
Commercial fishers	52	4. Hook and line fishers
Hook and line fishers	50	5. Reed/grass harvesters
Reed/grass harvesters	48	
Polers	40	
Cattle herders	38	
Safari operators	35	

**Table 3** Proportions of key informants and their perceptions on level of risk of malaria infection and related livelihood activities

Livelihood activities	Proportion of key informants (%) by perception of level of risk ( $n = 40$ )			
	High	Medium	Low	Don't know
Commercial fishing	62.5	22.5	10	5
Grass harvesting	50	20	15	15
Reed harvesting	47.5	17.5	25	10
Livestock herding	45	7.5	32.5	15
Hook and line	42.5	17.5	32.5	7.5
Arable farming	42.5	22.5	25	10
Tourist poling	40	15	22.5	22.5
Basket Fishing	37.5	22.5	27.5	12.5
<i>Tswii</i> harvesting	37.5	12.5	32.5	17.5
Tour guiding	35	15	15	35
<i>Molapo</i> farming	30	12.5	10	47.5
Basket weaving	20	12.5	50	17.5

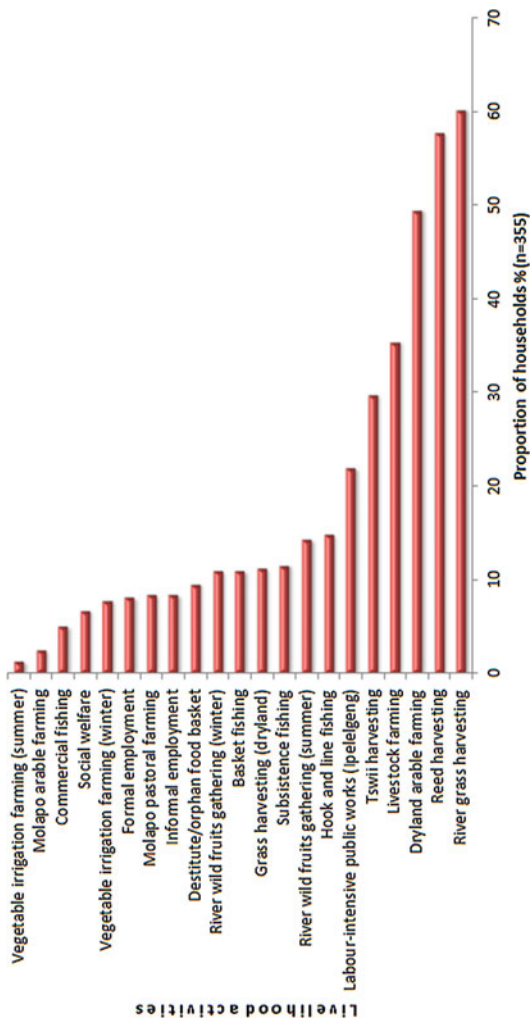
Basket weaving was perceived by 50% of interviewees as less likely to expose households and community members to malaria. Furthermore, *molapo* farming was one of the activities viewed as less likely to expose households and community members to malaria being stated by 30% interviewees. However, most interviewees (47.5) indicated that they did not know the likely level of exposure to malaria for *molapo* farming households and community members. This could be due to insufficient knowledge on *molapo* farming among Shakawe and Ngarange communities. Studies have indicated that *molapo* farming is not widely practiced in these communities compared to their counterparts in the mid- and lower parts of the Okavango Delta.

Results from the socioeconomic survey (Fig. 5 below) indicated that the top five livelihood activities undertaken by households in Shakawe were river grass harvesting in which 60% of households were involved, reed harvesting (58%), dryland/rain-fed arable farming (49%), livestock farming (35%), and *tswii* (waterlily or *Nymphaea* tuber) harvesting (30%).

These results corroborated key informant interview results on four of the five livelihood activities. Although hook-and-line fishing and commercial fishing were indicated as possible high-risk activities, the socioeconomic survey indicated that these livelihood activities were undertaken by a low proportion of households at 15% and 4.8%, respectively.

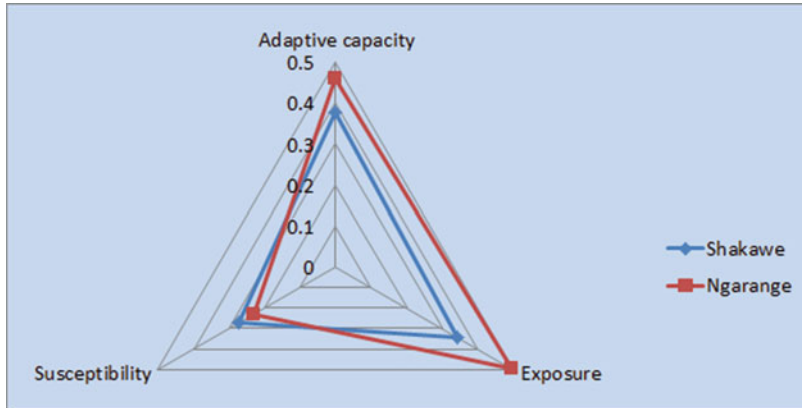
### Household Exposure, Susceptibility, and Adaptive Capacity

Survey results (Fig. 6) revealed that households in Ngarange village had higher exposure to malaria (0.5) than their counterparts in Shakawe (0.34). These results are quite realistic in that Ngarange village is located near a vast floodplain where water flow is limited compared to Shakawe, which is located along an escarpment.



**Fig. 5** Proportion of households and livelihood activities in Shakawe and Ngarange. Note: Other livelihood activities accounted for 0.3–0.6% of households





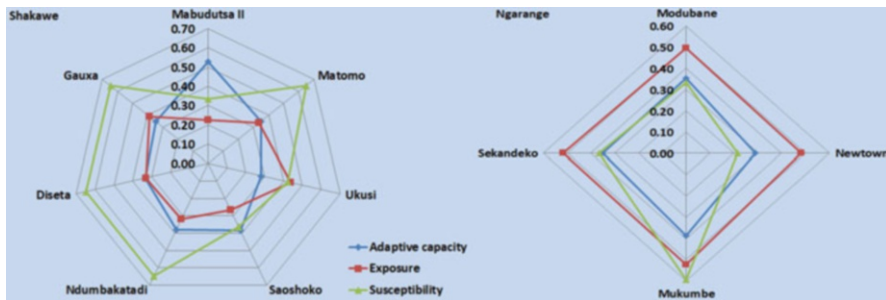
**Fig. 6** Village-level susceptibility, adaptive capacity and exposure to malaria

Ngarange households also had higher adaptive capacity (0.46) than those in Shakawe (0.38). Worth noting is that household exposure (0.5) to malaria in Ngarange was higher than adaptive capacity (0.46) meaning that within the village, households could not adequately prevent malaria transmission. In Shakawe, households had higher adaptive capacity (0.38) than exposure (0.34) meaning that they could prevent malaria transmission.

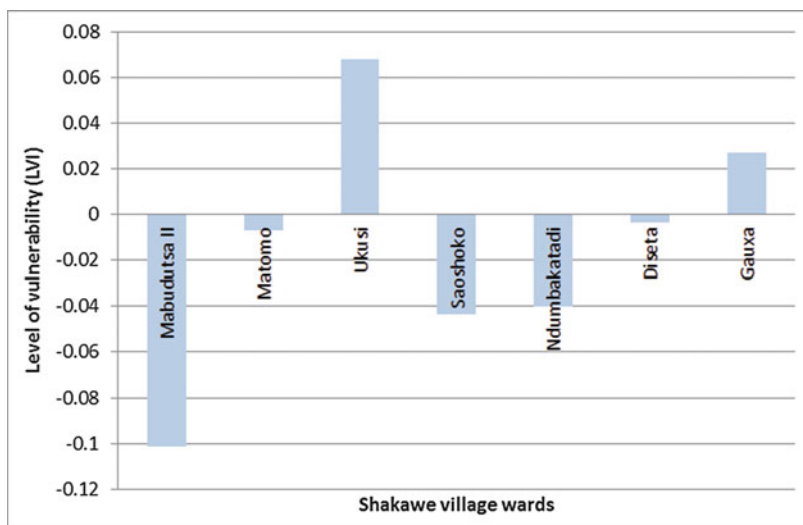
In both villages, the overall household susceptibility to malaria was lower than both adaptive capacity and exposure. Ngarange had a slightly lower susceptibility value (0.23) than Shakawe (0.27), which indicates that households in both villages had almost the same level of susceptibility to malaria. A further assessment of household exposure, adaptive capacity, and susceptibility within these two villages indicates that households in five out of seven wards in Shakawe had higher adaptive capacity than exposure to malaria. The five wards of Diseta, Matomo, Ndumbakatadi, Mabudutsa II, and Saoshoko had adaptive capacity that exceeded exposure values, whereas in the two wards of Gauxa and Ukusi, the exposure values of 0.39 and 0.44 were higher than the respective adaptive capacity values of 0.35 and 0.28 (Fig. 7).

This indicates that households in Gauxa and Ukusi wards of Shakawe were not adequately adaptable to malaria than their counterparts in the other five wards. Household susceptibility in to malaria in four of the seven wards of Shakawe was higher than both exposure and adaptive capacity. The susceptibility values in these wards were 0.65 or higher compared to both exposure and adaptive capacity values that ranged from 0.27 to 0.44.

In Ngarange, household exposure was higher than both adaptive capacity and susceptibility to malaria in all wards except in Mukumbe Ward, which had a susceptibility value of 0.63 that was higher than both adaptive capacity and exposure. These results indicate that households in all the wards in Ngarange are not adaptable and as such vulnerable to malaria, particularly Mukumbe Ward which had higher susceptibility than the other wards.



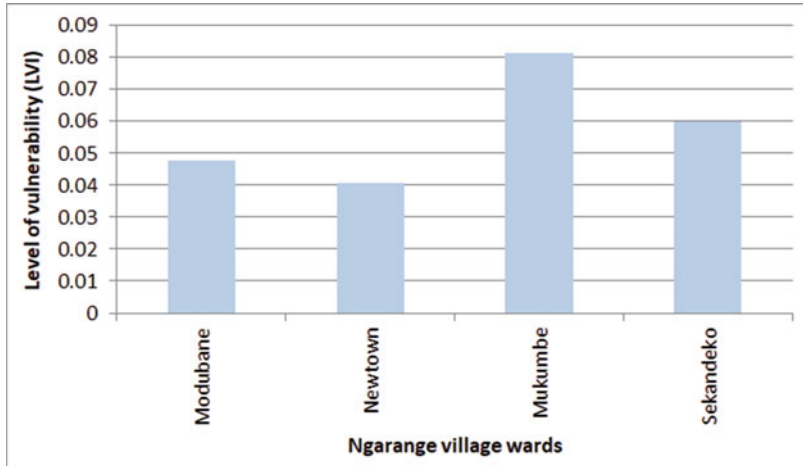
**Fig. 7** Household adaptive capacity, susceptibility and exposure to malaria in Shakawe and Ngarange



**Fig. 8** Level of household vulnerability (LVI) by ward in Shakawe

The overall livelihood vulnerability indices for these villages were  $-0.0092$  for Shakawe and  $0.0088$  for Ngarange, which confirms the above suggestion that households in Ngarange were not adequately adaptable and therefore vulnerable to malaria whereas their counterparts in Shakawe were not vulnerable. A further analysis indicates that households in Mabudutsa II ward of Shakawe had the lowest vulnerability score of  $-0.101$  (Fig. 8), which indicates that they could withstand the impacts of malaria much better than their counterparts in other wards.

The other four wards of Saoshoko ( $-0.043$ ), Ndumbakatadi ( $-0.04$ ), Matomo ( $-0.007$ ), and Diseta ( $-0.003$ ) also had low vulnerability scores. The two wards of Ukusi ( $0.068$ ) and Gauxa ( $0.027$ ) were vulnerable to malaria given that they had positive values. The vulnerability scores for the two wards of Matomo and Diseta



**Fig. 9** Level of household vulnerability (LVI) by ward in Shakawe

were close to the value of zero, which indicates that even though these two wards were not vulnerable, any slight decline in adaptive capacity or increase in exposure to malaria may render households in these two wards vulnerable to malaria.

In Ngarange, all wards were vulnerable to malaria, Mukumbe Ward having the highest vulnerability value of 0.08 whereas Newtown Ward had the lowest vulnerability at 0.04 (Fig. 9).

A further analysis indicated that households in the two most vulnerable wards of Mukumbe and Sekandeko in Ngarange were the most susceptible and least adaptable to malaria.

## Discussion and Conclusion

This chapter assessed household access to water resources as well as vulnerability to malaria in the Okavango Delta. The results indicate that household access to natural capital was much higher than that of other types of capital. Households mostly engaged in nature-based livelihood activities such as rain-fed arable agriculture, livestock, and the harvesting of aquatic reed, river grass, and *tswii* (nymphaea). Most Ngarange households engaged in nature-based livelihoods than their counterparts in Shakawe village, which was relatively more urbanized than Ngarange. Social capital was the least accessed of all the five forms of capital. It has also been demonstrated that households in Ngarange were more vulnerable to malaria than their counterparts in Shakawe and that this vulnerability emanated from high-household exposure mainly due to low capacity to adapt to malaria than their counterparts in Shakawe.

Due to high access to natural capital compared to other capital forms, households engaged in nature-based livelihood activities. This is typical of most rural communities in developing countries, particularly those residing in wetlands of sub-Saharan

Africa (Babulo et al. 2008; Rebelo et al. 2010; Angelsen et al. 2014). As earlier indicated in the conceptual framework, households' choice of livelihood activity depends on access to capital such that the most accessed type of capital may determine the main livelihood activity in any livelihood portfolio (Ellis 2000; Berkes and Folke 1998).

Access to social capital was lower than that of other capital forms contrary to expectation that this form of capital is higher in rural communities than in urban settings. Key informants attributed this low access to social capital to loss of culture, breakdown in family ties, a rise in individualism and general lack of cooperation within the village community. Low access to social capital may have adverse impacts on the well-being of households given that cultural diversity, social cohesion, and network are critical components of social sustainability (Munasinghe 2000).

Households in Ngarange were found to be more vulnerable to malaria than their counterparts in Shakawe. This vulnerability could be attributed to high exposure to malaria partly due to type of housing, and household practices relating to malaria prevention. Some studies have posited that malaria transmission is related to type of housing, and with increased urbanization and change of housing structure malaria transmission is likely to decrease in sub-Saharan Africa (Saugeon et al. 2009; Parnell and Walawege 2011). Household livelihood activities (such as agriculture) and practices have also been found to be confounding factors for malaria transmission, in Africa and Southeast Asia even in urban communities (Klinkenberg et al. 2008). Effectively, malaria transmission directly relates to type of housing, preventive measures, and practices relating to mosquito bites avoidance (Tusting et al. 2016).

Vulnerable groups such as pregnant women, under-five children, and the elderly require targeted programs with emphasis on availing the means to prevent malaria transmission. There is a need for long-term, sustained prevention, and control to reduce and/or eliminate malaria in the Okavango Delta and Botswana, in general.

---

## References

- Adger WN (2006) Vulnerability. *Glob Environ Chang* 16:268–281
- Angelsen A, Jagger P, Babigumira R, Belcher B, Hogarth NJ, Bauch S, Rner JB, Smith-Hall C, Wunder S (2014) Environmental income and rural livelihoods: a global-comparative analysis. *World Dev* 64:S12–S28
- Arntzen J (1989) Environmental pressure and adaptation in rural Botswana. PhD thesis, Vrije University of Amsterdam, Amsterdam
- Babulo B, Muys B, Nega F, Tollens E, Nyssen J, Deckers J, Mathijs E (2008) Household livelihood strategies and forest dependence in the highlands of Tigray, northern Ethiopia. *Agric Syst* 98:147–155
- Bates I, Fenton C, Gruber J, Laloo D, Lara AM, Squire SB, Theobald S, Thomson R, Tolhurst R (2004) Vulnerability to malaria, tuberculosis, and HIV/AIDS infection and disease. Part 1: determinants operating at individual and household level. *Lancet Infect Dis* 4:267–277

- Berkes F, Folke C (1998) Linking social and ecological systems for resilience and sustainability. In: Berkes F, Folke C, Colding J (eds) *Linking social and ecological systems: management practices and social mechanisms for building resilience*. Cambridge University Press, Cambridge
- Central Statistics Office (2009) 2008 Botswana AIDS impact survey III statistical report. Central Statistics Office, Gaborone
- Chihanga S, Haque U, Chanda E, Mosweunyane T, Moakofhi K, Jibril HB, Motlaleng M, Zhang W, Glass GE (2016) Malaria elimination in Botswana, 2012–2014: achievements and challenges. *Parasit Vectors* 9:99. <https://doi.org/10.1186/s13071-016-1382-z>
- Ellis F (2000) *Rural livelihood diversity in developing countries*. Oxford University Press, Oxford
- Farrington J, Carney D, Ashley C, Turton C (1999) *Sustainable livelihoods in practice: early applications of concepts in rural areas*. Natural resources perspectives paper number 42. Overseas Development Institute, London
- Folke C (2001) Socio-ecological resilience and behavioral responses. <http://www.beijer.kva.se/publications/pdf-archive/Disc155.pdf>. Accessed 07 June 2018
- Hahn MB, Riederer AM, Foster SO (2009) The livelihood vulnerability index: a pragmatic approach to assessing risks from climate change variability and change – a case study in Mozambique. *Glob Environ Chang* 19:74–88
- Intergovernmental Panel on Climate Change [IPCC] (2007) *Climate change 2007: impacts, adaptation and vulnerability. Contribution of working group II to the fourth assessment report of the Intergovernmental Panel on Climate Change*. Cambridge University Press, Cambridge, UK
- Klinkenberg E, McCall PJ, Wilson MD, Amerasinghe FP, Donnelly MJ (2008) Impact of urban agriculture on malaria vectors in Accra, Ghana. *Malar J* 7:151
- Lewis JJC, Ronsmans C, Ezeh A, Gregson S (2004) The population impact of HIV on fertility in sub-Saharan Africa. *AIDS* 18(2):S35–S43
- Marshall NA, Marshall PA, Tamelander J, Obura D, Malleret-King D, Cinner JE (2009) A framework for social adaptation to climate change: sustaining tropical coastal communities and industries. IUCN, Gland
- Motsholapheko MR, Kgathi DL, Vanderpost C (2011) Rural livelihoods and household adaptation to extreme flooding in the Okavango Delta, Botswana. *Physics and Chemistry of the Earth* 36:984–995
- Munasinghe M (2000) Development, equity and sustainability (DES) in the context of climate change. *Guidance Papers on the Cross Cutting Issues of the Third Assessment Report of the IPCC*, 69–90
- O’Laughlin B (2002) Proletarianization, agency and changing rural livelihoods: forced labor and resistance in colonial Mozambique. *J South Afr Stud* 28(2):511–530
- Parnell S, Walawege R (2011) Sub-Saharan African urbanization and global environmental change. *Glob Environ Chang* 21(1):12–20
- Rebelo LM, McCartney M, Finlayson C (2010) Wetlands of sub-Saharan Africa: distribution and contribution of agriculture to livelihoods. *Wetl Ecol Manag* 18(5):557–572
- Ross A, Morgan D, Lubega R, Carpenter LM, Mayanja B, Whitworth JA (1999) Reduced fertility associated with HIV: the contribution of pre-existing subfertility. *AIDS* 13:2133–2141
- Saugeon C, Baldet T, Akogbeto M, Henry MC (2009) Will climate and demography have a major impact on malaria in sub-Saharan Africa in the next 20 years? *Med Trop* 69(2):203–207
- Scoones I (1998) *Sustainable rural livelihoods: a framework for analysis*. IDS working paper 72. Institute of Development Studies, London
- Small L (2007) The sustainable rural livelihoods approach: a critical review. *Can J Dev Stud* 28:27–38
- Statistics Botswana (2011) *Botswana core welfare indicators (poverty) survey of 2009/10 preliminary results*. Statistics Botswana, Gaborone
- Tusting LS, Rek J, Arinaitwe E, Staedke SG, Kanya MR, Cano J, Bottomley C, Johnston D, Dorsey G, Lindsay SW, Lines J (2016) Why is malaria associated with poverty? Findings from a cohort study in rural Uganda. *Infect Dis Poverty* 5:78
- United Nations Development Program [UNDP] (1990) *Human development report*. UNDP, New York

- Wisner B, Blaikie P, Cannon T, Davis I (2004) *At risk: natural hazards, people's vulnerability and disasters*, 2nd edn. Routledge, London
- World Health Organization [WHO] (2019) *World malaria report 2019*. World Health Organization, Geneva

**Open Access** This chapter is licensed under the terms of the Creative Commons Attribution 4.0 International License (<http://creativecommons.org/licenses/by/4.0/>), which permits use, sharing, adaptation, distribution and reproduction in any medium or format, as long as you give appropriate credit to the original author(s) and the source, provide a link to the Creative Commons license and indicate if changes were made.

The images or other third party material in this chapter are included in the chapter's Creative Commons license, unless indicated otherwise in a credit line to the material. If material is not included in the chapter's Creative Commons license and your intended use is not permitted by statutory regulation or exceeds the permitted use, you will need to obtain permission directly from the copyright holder.





# Digital Platforms in Climate Information Service Delivery for Farming in Ghana

# 61

Rebecca Sarku, Divine Odame Appiah, Prosper Adiku,  
Rahinatu Sidiki Alare, and Senyo Dotsey

## Contents

Introduction .....	1248
Methodology .....	1250
Results .....	1251
Actors Involved in the Provision of CIS with ICTs .....	1251
Digital Platforms for the Delivery of CIS to Smallholder Farmers .....	1252
Category of Farmers' Use of CIS Delivered Through ICTs .....	1263
Type of Information Needed by Different Categories of Farmers .....	1265
Financing and Governance Arrangement for the Delivery of CIS with Digital Tools ....	1267

This chapter was previously published non-open access with exclusive rights reserved by the Publisher. It has been changed retrospectively to open access under a CC BY 4.0 license and the copyright holder is “The Author(s)”. For further details, please see the license information at the end of the chapter.

R. Sarku (✉)  
University for Development Studies, Tamale, Ghana

D. O. Appiah  
Environmental Management Practice Research Unit, Department of Geography and Rural Development, Faculty of Social Sciences, Kwame Nkrumah University of Science and Technology, Kumasi, Ghana  
e-mail: [doappiah.cass@knust.edu.gh](mailto:doappiah.cass@knust.edu.gh)

P. Adiku  
Institute for Environment and Sanitation Studies, College of Basic and Applied Sciences, University of Ghana, Accra, Ghana

R. S. Alare  
Faculty of Earth and Environmental Sciences, Department of Environmental Sciences, C.K. Tedam University of Technology and Applied Sciences, Navrongo, Ghana

S. Dotsey  
Urban Studies and Regional Science, Gran Sasso Science Institute, L'Aquila, Italy

---

Discussion of Emerging Issues .....	1270
Conclusion .....	1271
References .....	1272

---

## Abstract

Phone-based applications, Internet connectivity, and big data are enabling climate change adaptations. From ICT for development and agriculture perspectives, great interest exists in how digital platforms support climate information provision for smallholder farmers in Africa. The vast majority of these platforms both private and public are for delivering climate information services and for data collection. The sheer number of digital platforms in the climate information sector has created a complex information landscape for potential information users, with platforms differing in information type, technology, geographic coverage, and financing structures and infrastructure. This chapter mapped the existing climate information services and examined their impact on policy and practices in smallholder farming development in Africa, with a focus on Ghana. Specifically, the chapter provides highlights of digital platforms available to smallholder farmers and agricultural extension agents, analyzes the public and/or private governance arrangements that underpin the implementation of digital climate information delivery, and assesses the potential of these platforms in scaling up the use of climate information. The chapter contributes to understanding the dynamics of climate information delivery with digital tools in Africa, and suggests a future research agenda.

---

## Keywords

Climate information services · Digital platforms · Smallholder farming · Ghana · Africa

---

## Introduction

Climate change and variability are complex problems affecting different geographical regions, people, and socio-ecological systems. Africa is likely to be the most adversely affected due to its overdependence on climate-sensitive sectors for development. For instance, studies have shown that Ghana is highly prone to drought; temperatures are projected to increase at the rates of 3.8% (1.02 °C), 5.6% (1.5 °C), and 6.9% (1.8 °C) for the near future (2040), mid-future (2060), and far future (2080), respectively, and rainfall is expected to become more erratic (Dumenu and Obeng 2016). The changing climate conditions and the projections of increased temperature and precipitations have implications for smallholder farming and household food security.

The Intergovernmental Panel on Climate Change (IPCC), in recognition of the heightened climate impacts, vulnerabilities, and need for adaptation, encourages the adoption of a cross-sectoral and integrated approach to the development and



adoption of long-term and sustainable adaptation and mitigation strategies (IPCC 2014). Adaptation, along with mitigation efforts, is a complementary approach for reducing and managing the risks associated with climate change and sustainable development particularly in developing countries (Federspiel 2013; IPCC 2014). Countries are therefore expected to develop mechanisms (plans, programs, and policies) that enhance resilience and provide support for local practices for climate change adaptation (Dougill et al. 2017).

To support farmers to better adapt to climate change and variability, context-relevant, accurate, and timely climate information services (CIS) have become a relevant strategy (World Meteorological Organisation 2015). CIS range from climate data delivery, transformation of climate-related data together with context information into customized products such as projections, forecasts, trends, economic analyses, analysis on best practices, development and evaluation of solutions, user interactions, and capacity development (Vaughan and Dessai 2014; Vogel et al. 2019). Through the provision of CIS, farmers can make crucial decisions regarding when to plough, sow seed, apply fertilizer, and harvest, thus, reducing exposure to risks (Tall et al. 2014). It also provides actors such as agricultural extension agents, researchers, and policy-makers with the requisite knowledge to support farmers to adapt to climate change. Despite the relevance of CIS, smallholder farmers are unable to access it due to high illiteracy rates, technical information, financial constraints, sociocultural barriers, and infrastructural challenges (Singh et al. 2016, 2018). In this regard, the Global Framework for Climate Services (GFCS) has become a prominent mechanism to address these challenges (World Meteorological Organisation 2015). The framework recognizes the role of digital tools for the provision of tailored CIS to meet the needs of users including smallholder farmers (Singh et al. 2016). Digital tools include new ICTs such as smartphones and old ICTs such as radio and television (Asenso and Mekonnen 2012). The growing innovations associated with ICTs create new opportunities for information-sharing, alternative forms of connectivity, financing models, and governance arrangements (Bennett and Segerberg 2012; Karpouzoglou et al. 2016; Soma et al. 2016).

Despite the opportunities associated with the application of ICTs for the delivery of CIS in Africa, opinions abound regarding the extent to which smallholder farmers use ICT-delivered CIS.

Some of these opinions include:

- Old technologies such as radio, television, and farmers' networks remain the most relevant and cost-efficient ICT platforms for the delivery of CIS.
- ICTs remain underused despite the hype due to the lack of relevant content information, lack of or poor infrastructure, low affordability, low literacy, lack of access to ICTs, and absence of conducive social norms, such as trust.
- ICTs are social transformational tools which are enabling farmers to become co-producers of CIS rather than consumers.
- The delivery of ICT-based CIS results in changes in institutional logics in farming communities in the form of new interactions and information exchange and other forms of innovation intermediation.

The differences in the opinions on the application of ICTs for the delivery of CIS for smallholder farmers may be attributed to the relatively underdeveloped CIS sector in Africa (Graham et al. 2015; Hansen et al. 2019). This can also be attributed to the fact that studies on CIS use among smallholder farmers in Africa are often framed under themes, such as gender, accessibility, local content development, and local knowledge, while ICTs are mostly treated as sub-themes. Based on this gap, this chapter examines the application of digital tools for the delivery of CIS for smallholder farmers with a focus on Ghana. This chapter is guided by the following questions:

- Who are the actors of ICT-based CIS delivery?
- What digital tools are used for the delivery of CIS for smallholder farming in Ghana?
- Which category of farmers applies CIS?
- What financing modes and governance arrangements are used for the delivery of CIS?

The chapter contributes to the literature on climate change adaptation in two ways: First, it provides an overview of the landscape of digital tools that are being used to provide CIS to smallholder farmers in Ghana. Second, it provides insights and directions for further research on the delivery of CIS with digital tools in Ghana in support of adaptation. The chapter consists of an “[Introduction](#)”, “[Methodology](#)”, “[Results](#)”, and “[Conclusion](#)” sections.

---

## Methodology

To generate data for the chapter, a systematic literature review was carried out with three databases: Scopus, Google Scholar, and CAB Abstracts. Keyword searches of terms “Climate services” AND “Ghana,” “Climate information services” AND “Ghana,” “Weather information” AND “Ghana,” and “Weather information services” AND “Ghana” were entered as queries. “Weather and climate information services” AND “Ghana,” “Climate and weather enterprise” AND “Ghana,” and “Agrometeorological services AND Ghana” were conducted. Other queries include “Hydroclimatic information,” “Weather information services,” “Agroclimatic information,” “Services,” and “Information.” Articles that had the abovementioned key terms in their title or abstract were selected through a process of “abstract sifting” to help align with the language, concepts, and subject matter. Since CIS is still in its infancy and now gaining attention in the literature in Africa, limited literature was generated for the period 2000 to 2020. Hence, the snowball strategy was used to expand the scope of the literature by identifying additional literature from the selected peer-reviewed journals. Other literature which had combined themes on CIS and agricultural extension or had a regional scope on Africa with case studies on Ghana were also selected.

Additionally, desktop search was conducted by reviewing the websites of public, nongovernmental organizations (NGOs) and business organization that provide CIS in Ghana including ESOKO; MFarm; Farmerline; e-agricultural platform; Climate Change, Agriculture and Food Security (CCAFS); African Cashew Initiative, Ignitia, Technical Centre for Agricultural and Rural Cooperation ACP-EU (CTA); US Agency for International Development (USAID); and Agricultural Cooperative Development International and Volunteers in Overseas Cooperative Assistance (ACDI/VOCA). Relevant policy documents, thesis, and gray literature were also reviewed to provide information for the analysis. The limitation of the method used for the selection of literature for the chapter is the application of only three databases. Also, new publications could have been made after the literature search was conducted. The intertwining nature of CIS, ICTs, and other broad themes could have resulted in the omission of certain literature that might have relevant information on the application of ICTs for smallholder farming in Ghana.

The content analysis of the selected literature was guided by the research question and core themes: ICTs, digital tools, CIS, smallholder farming, and Ghana. Additionally, the content of the literature was analyzed based on the geographical settings, governance arrangements, geographic scope, type of digital tools or products, content of the digital messages, stages in their development, targets in the farming sector, and organizations providing CIS with ICTs. Here, the content analysis helped categorize and structure the sub-themes in order to select new themes emerging from the literature.

---

## Results

### Actors Involved in the Provision of CIS with ICTs

The actors providing CIS with ICTs to smallholder farmers were grouped broadly since a more comprehensive analysis indicating all actors is beyond the scope and objective of this chapter.

Actors who collected weather data with ICTs include the Ghana Meteorological Agency (GMet). At the international level, international weather organizations (National Oceanic and Atmospheric Administration (NOAA) and European Organisation for the Exploitation of Meteorological Satellites (EUMETSAT)), the European Centre for Medium-Range Weather Forecasts (ECMWF), the National Aeronautics and Space Administration (NASA), UKMet, and the World Meteorological Organization also provide weather data (Mills et al. 2016; Usher et al. 2018). Farmers also constitute CIS data providers as they also generate information on local weather indicators in their communities for co-creating weather information with formal scientific models (see Kadi et al. 2011; Nyadzi 2020).

Intermediary CIS providers add value to the weather data. They include business weather data providers, like aWhere, Satelligence, and Weather Impact, mobile telecommunication network providers, and ICT platform providers (e.g., Prepez) (Singh et al. 2018), while some knowledge institutions also play this role. Some

actors double as intermediary CIS providers and also deliver the information directly to farmers with their ICT platforms, e.g., Farm Radio International, MFarm, Esoko, Farmerline, and VOTO Mobile among others.

The delivery of CIS information for farmers is carried out by a variety of actors from the government agencies, e.g., GMet, GTV, National Disaster Management Organization, and regional public radio channels (Adjin-Tettey 2013). International development partners in collaboration with ICT companies also provide CIS to farmers (Mohammed 2018). Businesses, commercial radio channels, and agri-input companies are also involved in the delivery of CIS to farmers. Other actors include processors, input suppliers, aggregators, exporters, agricultural service providers, and NGOs. They focus on providing complex interventions (e.g., demonstrations, visual aids, agronomic inputs, logistics, and resources) to ensure farmers' access to information (Slavova and Karanasios 2018).

## Digital Platforms for the Delivery of CIS to Smallholder Farmers

This section is divided into three subsections.

### Data Collection and Production of CIS

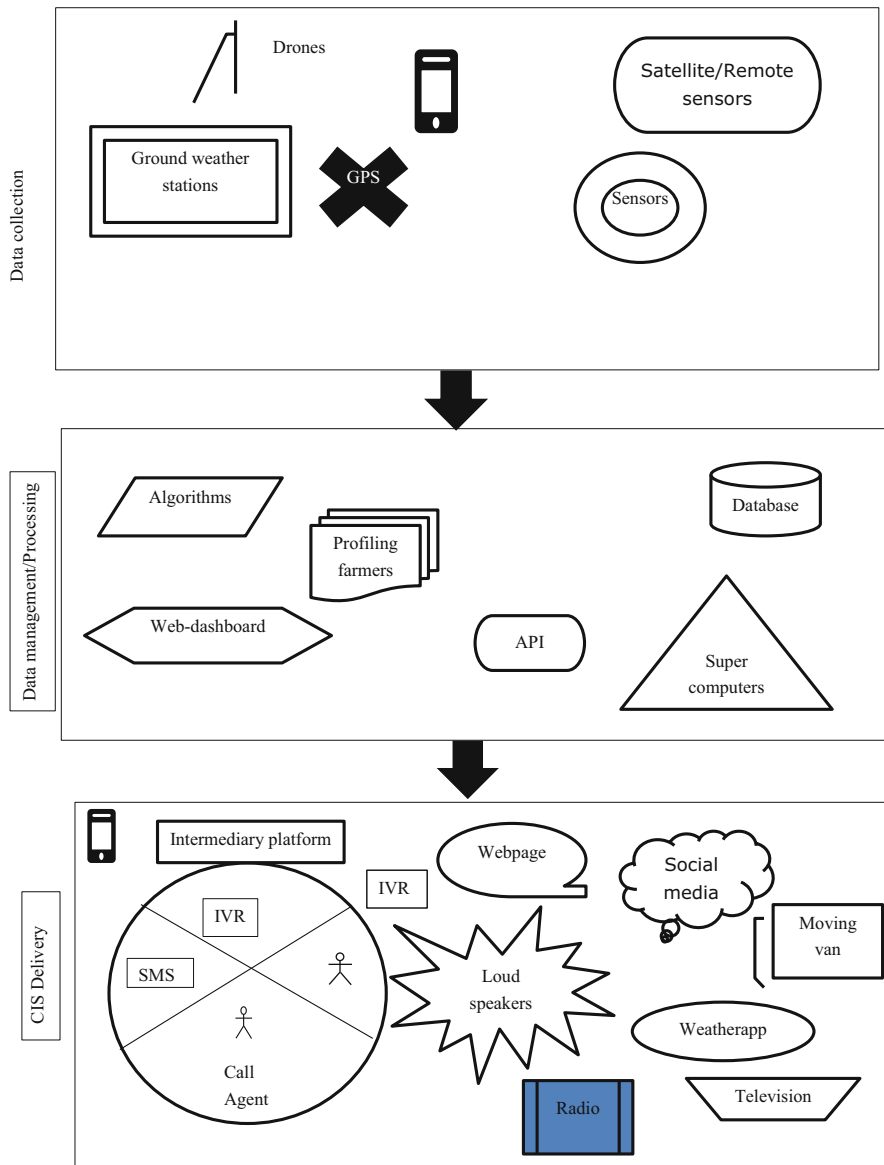
Few studies provide information on the application of ICTs for collecting data and producing CIS for the smallholder farming sector. Even so, some studies which captured data collection at the farming community level were identified. These include ground-level measurements and nowcasts that are derived from ICT-enabled platforms such as algorithms, automatic weather stations, weather models and historical observational weather data, automatic rain gauge, sensors, data logger, and ground-level radio with the aid of mobile telecommunication network radar (Gotamey et al. 2018; Usher et al. 2018; Nyadzi 2020). Global Positioning Systems (GPS) are also used to pick the location of communities, and some of the abovementioned technologies are triangulated to provide location-specific data. The mobile phone or smart technologies are also used to transmit data from weather stations in different locations to weather information producers, although carried out on a trial basis (Akudbillah 2017; Usher et al. 2018). In the case of the actual provision of weather data, the technologies are mostly based outside Ghana, and so the role of the Internet becomes relevant for data transmission (Chudaska 2018). For example, supercomputers and cell tower-mounted or co-located automatic weather stations capitalize on the increasing availability of secure, powered, connected telecommunication infrastructure in Ghana. Smartphones are used to collect personal data, type of crops cultivated, and location with Geographic Information Systems (GISs), and the data is stored to a server. Also, some organizations have researched the production of CIS with ICTs, such as chip sensors, in the northern part of the country for monitoring temperature and other weather indicators in local communities (Mills et al. 2016; Usher et al. 2018). The collection of local weather indicators with a smartphone for co-producing location-specific CIS has also been carried out on a trial basis (Nyadzi 2020; Sarku et al. forthcoming).

## Data Management and Analysis

CIS information providers usually have supercomputers, data processing, analytical models, sophisticated algorithm proprietary data sets, or multilayer ICT architecture with a system of modular components (functionalities and interfaces) that communicates with a central cloud application, which includes a central database (see Fig. 1) to interpret and convert raw data into accurate forecasts. For example, Ignitia uses supercomputers to provide real-time weather forecasts to farmers. The geospatial data collected from many locations over time are collated in a central database and then interpreted by experts (Chudaska 2018). Application Programming Interfaces (APIs) are used to deliver real-time CIS data to systems and businesses (e.g., aWhere and Farmerline). Cloud computing is used to limit the impact of unstable power and air conditioning systems in computer rooms (e.g., aWhere and Ignitia). CIS bundling is one of the key marketing strategies of market-led ICT platform information providers. It involves the collection of GPS coordinates and profiles on farmers' socioeconomic characteristics to provide value-added services such as agronomic advisory (Etwire et al. 2017; Partey et al. 2020). Some pilot projects indicate the use of different ICTs to integrate the weather data with soil and crop advice and make suggestions for minimizing losses and optimizing inputs (Eitzinger et al. 2019). Decision-support systems such as RainCast application have data source that uses OpenWeatherMap with the aid of an API to extract weather data (Omoine et al. 2013). From the API, the app retrieves temperature or weather conditions for the day and the time the condition is expected to occur for as much as 5 days ahead (Dinku et al. 2018; Gotamey et al. 2018). Mobile telecommunication networks also help to locate users in a variety of ways through network-based call detail records (CDRs), triangulation via LBS, and user registration, which enable the creation and delivery of highly localized, farm-level forecasts based on user location.

## Information Delivery

To enable the delivery of CIS to farmers, the focus is mostly on the medium of information delivery due to its influence on the usability of the information for decision-making in farming (Dilling and Lemos 2011; Lemos et al. 2012). Often a distinction is made in the literature between existing and emerging technologies as "old" and "new" ICTs, respectively, based on different factors. From the social perspective, ICTs are classified as new, due to the ability to mostly complement or spur real-life interactions, and two-way communication (Materia et al. 2015; Sulaiman et al. 2012; Slavova and Karanasios 2018). They also enable alternative forms of connectivity and virtual communities for different actors (Bennett and Segerberg 2012; Cieslik et al. 2018). Another factor that is used to distinguish ICTs as either old or new is based on the capacity of the technology to collect data, process, and deliver information within a short period across space and time (Asenso-Okyere and Mekonnen 2012; Munthali et al. 2018). Also, ICTs are classified as new based on the innovations attached to the technologies such as the ability to provide mobile push-and-pull services (e.g., social media) (Bell 2015; Barber et



**Fig. 1** Flow chart indicating how digital platforms are used for the delivery of climate information services

al. 2016; Suchiradipta and Saravanan 2016). In some instances, new technologies are identified to support environmental monitoring through the involvement of citizens in data collection (Buytaert et al. 2014; Karpouzoglou et al. 2016; Nyadzi 2020). With regard to the governance or institutional perspective, old ICTs have remained

large under the control of state organizations, while new ICTs seem uncontrollable and have transformative powers due to the numerous actors who use it to provide information across space and time (Mol 2008; Soma et al. 2016). In reference to these factors, a plethora of new ICTs is identified for the delivery of CIS for farming (Akudugu et al. 2012; Munthali et al. 2018).

### **New ICT**

Mobile phones for CIS delivery are increasing in Ghana due to its different functionalities. As tools for oral interpersonal communication, mobile phones have a high level of ownership among farmers (Anuga et al. 2019). Farmers stressed the importance of mobile phones as tools for accessing formal and informal networks. For instance, they are used to contact agricultural extension agents (e.g., dealing with pests) or reach out to fellow farmers for assistance (Alhassan et al. 2013). There are several advantages associated with the use of a mobile phone for the delivery of CIS (see Table 1). The functions of mobile phones used by RainCast for the delivery of CIS include a selection of options for language, location, type of forecast required, and other information related to farming (Omoine et al. 2013).

Interactive voice response (IVR) is a voice-based channel of communication; others include call centers and voicemail (Zougmore et al. 2018). The e-extension platform for the Ministry of Food and Agriculture (MoFA) has a mobile application called Farmer Direct which allows farmers to call in and receive pre-recorded information (Modernizing Extension and Advisory Services (MEAS) 2012; Munthali et al. 2018).

The voice/audio and video messages are in the form of pre-recorded information in the local languages to meet the needs of different categories of farmers. The voice forum is a feature that allows farmers to ask questions by calling a toll-free helpline with a short code. Agricultural extension agents can answer questions via a web interface, and answers are sent to farmers as voice SMS (Slavova and Karanasios 2018).

Short message services (SMS) are short written text with description on weather conditions and other agricultural information on how to tackle pests or diseases, agricultural techniques, optimum planting times, available subsidies, and weather forecasts, local fairs, and crop prices (Aker 2011). For example, Ignitia Ghana partners with ACIDI/VOCA to deliver weather forecast through SMS to farmers who are part of the Agricultural Development and Value Chain Enhancement (ADVANCE) II project. Automated SMS alerts are also used for the delivery of CIS (Mohammed 2018).

Weather apps such as AccuWeather, Rainsat, and others are installed on smartphones to provide a daily forecast. Some of these apps provide a forecast for 48 h or the entire week. Some weather apps are available to specific network subscribers (Caine et al. 2015). The smartphone has also enabled user-specific weather apps with an interface designed for several functionalities and applications for farmers (Gotamey et al. 2018).

Mobile-based-only platforms include MTN and Vodafone telecommunication network scribe to access CIS with SMS and IVR. Vodafone farmer clubs have

**Table 1** Overview of ICT platforms for information delivery to farmers

Categories	Type of ICT platform	Application during the farming seasons	Advantages	Challenges
Voice-based	Mobile phone	All-year usage	<ul style="list-style-type: none"> <li>• Social identities through personalized ringtones</li> <li>• More durable and portable</li> <li>• Can be used in numerous ways due to the multiplicity of functions for illiterate farmers</li> <li>• Missed calls can be traced</li> <li>• Cheap technology</li> <li>• Allows for two-way interaction with other farmers or agricultural extension agents</li> <li>• Two-way flow of information provides opportunities for information providers to generate feedback</li> </ul>	<ul style="list-style-type: none"> <li>• Access to messages not free</li> <li>• Illiterate farmers cannot access messages delivered in the English language</li> <li>• Novice users cannot trace or navigate through the phone to trace missed calls</li> <li>• Most existing phone-based services are not free, and this raises the issue of information asymmetry where farmers who can pay access to information</li> <li>• Loss of phone results in loss of messages and cost implications</li> </ul>
	IVR (interactive voice response)	Used only during the farming season	<ul style="list-style-type: none"> <li>• Available on feature phones</li> <li>• Interaction with information provider is possible</li> <li>• Accessible for illiterate users</li> <li>• Has the potential to reach more people</li> <li>• Richer content</li> <li>• Cost-effective alternative to access information</li> </ul>	<ul style="list-style-type: none"> <li>• More expensive than a text message</li> <li>• Require training to use</li> </ul>
	Television	All-year usage	<ul style="list-style-type: none"> <li>• Free access</li> <li>• Uses images and symbols</li> <li>• Oral presentation</li> </ul>	<ul style="list-style-type: none"> <li>• No interaction with viewers</li> <li>• Access affected by the unavailability of electricity</li> <li>• Weak network signals and poor reception</li> <li>• Communication of CIS is in English</li> <li>• TV ownership not common among farming households</li> <li>• Unfamiliarity with symbols depicting weather conditions such as rainfall or sunshine</li> </ul>



Interactive community and commercial radio	Mainly at the onset of the farming season	<ul style="list-style-type: none"> <li>• Can be powered by batteries or solar panels</li> <li>• Free access to information</li> <li>• Exist in portable forms and movable</li> <li>• Multiplicity of radio channels in a specific area with wide frequency coverage</li> <li>• Presentation of information in (multiple) local languages</li> <li>• Timely broadcast of CIS programs</li> <li>• Satisfies the needs of all listeners including illiterates</li> <li>• Engages different panelists with different knowledge levels</li> <li>• Formation of listenership groups in communities</li> <li>• Integrated with phone-in activity to enable listeners share experience, challenges, and questions</li> <li>• Discussions bridge gap in communication of uncertainties in the forecast</li> <li>• Uses voice prompts, vox pops, beep calls, Beep4Weather system, and pre-recorded information</li> <li>• Values farmers' local knowledge, cultural beliefs, and attitudes</li> <li>• Local contents embedded in discussions build trust in CIS</li> <li>• Level of dialogue is synonymous to face-to-face methods</li> <li>• Integrates a variety of ICTs into the programs, e.g., phone-in</li> </ul>	<ul style="list-style-type: none"> <li>• Provides less opportunity for in-depth discussion and interaction with panelists</li> <li>• Phone-in sessions during the in-studio discussion are limited</li> <li>• Schedule programs and limited time allotted for CIS programs throughout the week, e.g., 1 h per week</li> <li>• Program formulation can be top-down</li> <li>• CIS programs run mostly at the onset of the season</li> <li>• Possible altering of information in the process of translating from English to the local languages</li> <li>• Broadcasts are fleeting; one either hears them when they are broadcast, or they are missed</li> <li>• Limited ways of accessing missed programs unless they are recorded and played back</li> <li>• Affordability of batteries or solar-powered radio sets</li> <li>• Limited in facilitating learning-by-seeing or visual presentations</li> </ul>
--	---	---	--

(continued)

Table 1 (continued)

Categories	Type of ICT platform	Application during the farming seasons	Advantages	Challenges
	Video (YouTube)	All-year usage	<ul style="list-style-type: none"> <li>• Facilitate better comprehension of complex ideas, specifically for illiterate farmers</li> <li>• Access to mobile internet opens significant new possibilities for knowledge-sharing and exchange with social networks</li> <li>• Allows for visual display of data and discussions</li> </ul>	<ul style="list-style-type: none"> <li>• Not easily applicable in all devices</li> <li>• Poor Internet connectivity affects its use</li> </ul>
Text-based messaging	SMS (short message service)	All-year usage	<ul style="list-style-type: none"> <li>• Available on all mobile phones</li> <li>• Low-cost message</li> <li>• Low technical setup</li> <li>• Can be stored for later viewing or forwarded</li> <li>• Information is straightforward</li> <li>• Easily accessible on any mobile phone</li> <li>• It is readily available</li> </ul>	<ul style="list-style-type: none"> <li>• Deductions debited from call credit</li> <li>• SMS nuisance due to numerous messages from telecommunication networks</li> <li>• Requires two-sim phones to subscribe if farmers are subscribers of other networks</li> <li>• Information delivered in English</li> <li>• Inability to read information deters some farmers from accessing information</li> <li>• No graphic communication</li> <li>• Messages are sometimes too short to allow adequate comprehension of information</li> <li>• Limited communication of uncertainty</li> <li>• Scheduled delivery of SMS at fixed times</li> <li>• No provision of outlook forecast for the day</li> <li>• Lack of interactions</li> </ul>
	Mobile network based on platform	Used only during the farming season	<ul style="list-style-type: none"> <li>• Service providers enable free calls between subscribers</li> <li>• Access to an expert helpline (Vodafone 2015)</li> <li>• Simple and comprehensive messages</li> <li>• Voice SMS in 13 local languages</li> <li>• Provision of a variety of temporal CIS</li> </ul>	<ul style="list-style-type: none"> <li>• Disadvantages same as SMS</li> </ul>

Mobile weather apps for smartphones	Irregular use during the farming season	<ul style="list-style-type: none"> <li>• Almost unlimited</li> <li>• Informative and intuitive</li> <li>• Visualizations are possible</li> <li>• Symbols exist to illustrate CIS</li> <li>• Visualization capabilities in mobile apps help to overcome the challenge of limited literacy rate in rural communities</li> </ul>	<ul style="list-style-type: none"> <li>• Low level of smartphone ownership</li> <li>• Mobile data expensive</li> <li>• Unavailability of the Internet</li> <li>• Inability to use a smartphone</li> <li>• Complexity attached to navigating apps</li> <li>• Inaccessibility to the Internet to enable the use of online mobile apps</li> <li>• Many farmers are smartphone phobia due to language and literacy barrier</li> </ul>
Smartphones	Irregular use during the farming season	<ul style="list-style-type: none"> <li>• Smartphone application is simple and optimized for fieldwork usage</li> <li>• Variety of functions, e.g., social media, registration of farmers, pick GPS points, apps</li> <li>• Can be used for offline data collection, and data can be uploaded upon the availability of the Internet</li> </ul>	<ul style="list-style-type: none"> <li>• Difficulty in swiping sensitive screen, switching data, and renewal of Internet data and other more sophisticated functions</li> <li>• High cost of Internet data</li> <li>• Inaccessible Internet in most locations</li> <li>• Technology not coded in local language</li> <li>• Keyboard does not have alphabets for local languages</li> </ul>
Website	Irregular use during the farming season	<ul style="list-style-type: none"> <li>• Website that provides weather fore for 24 h</li> <li>• Focused on all regions in Ghana</li> </ul>	<ul style="list-style-type: none"> <li>• Offer limited opportunity for interactions</li> <li>• Limited Internet access affects its use in many rural communities</li> <li>• Farmers will find it difficult to read and interpret information by themselves because of limited literacy</li> </ul>
Newspaper and bulletins	Mostly used at the onset of the farming season or for outlook forecast	<ul style="list-style-type: none"> <li>• Written text suitable for literate farmers</li> </ul>	<ul style="list-style-type: none"> <li>• Constrained by low literacy rates</li> <li>• Scheduled publication deliveries</li> <li>• Available at certain periods of the year</li> <li>• Accessibility to a few farmers and in urban areas</li> </ul>

(continued)

Table 1 (continued)

Categories	Type of ICT platform	Application during the farming seasons	Advantages	Challenges
Intermediary platforms	Platform intermediaries	Used only during the farming season	<ul style="list-style-type: none"> <li>• Play intermediation roles</li> <li>• Engages farmers to identify their tacit knowledge and integration with scientific CIS</li> <li>• Foster continuous information flows and trust building</li> <li>• Collection of databases for information on farmers</li> <li>• Aids in scaling up access to CIS through the combination of SMS, call-in services, rural radio, agricultural extension or field agents, farmer organizations, and social networks</li> <li>• Offers learning opportunities in broader networks</li> </ul>	<ul style="list-style-type: none"> <li>• Inadequate experts to play the intermediation roles</li> <li>• Logistical constraints in staff deployment</li> </ul>
	Call center	Used only during the farming season	<ul style="list-style-type: none"> <li>• Provision of expert advice</li> <li>• Voice-based calls</li> <li>• Access the helpline by dialing a short code at a regular call rate</li> <li>• Provides tailored and interactive solutions</li> <li>• Offers timely responses to all category of farmers</li> <li>• Provides a mechanism to receive feedback on the service</li> <li>• Offers services in a variety of languages</li> <li>• Builds trusts in CIS</li> <li>• Helps in contextualizing the information and discuss risks</li> </ul>	<ul style="list-style-type: none"> <li>• Unavailable 24/7</li> <li>• Cost of call credit for farmers</li> </ul>

<p>In formal: van, loudspeakers, community information center</p> <p>Social media/ weather app</p>	<p>Mostly used at the onset of the farming season</p> <p>Irregular use during the farming season</p>	<p>Facilitates intensive face-to-face interaction</p> <ul style="list-style-type: none"> <li>• Can target a wide audience</li> <li>• Information presented in the local language</li> <li>• Relatively low cost</li> </ul> <p>Combines text, images, animations, symbols, and videos</p> <ul style="list-style-type: none"> <li>• Provides timely delivery of climate information</li> <li>• Low-cost information delivery</li> <li>• Enables information to travel easily</li> <li>• Attractive forms of communication</li> <li>• Can provide outlook forecast during the day</li> </ul>	<ul style="list-style-type: none"> <li>• Information not frequent</li> <li>• CIS available at a specific period of the season</li> <li>• Other social issues prioritized above CIS</li> </ul> <ul style="list-style-type: none"> <li>• Requires advance ICTs such as apps and smartphones</li> <li>• Not accessible to all farmers</li> <li>• Unavailability of the Internet and other infrastructures can be challenging</li> <li>• Inability or difficulty in using ICTs, e.g., mobile phone, smartphone</li> <li>• Farmers' inability to navigate several ICTs and read messages</li> <li>• Schedule delivery</li> <li>• Little local content and guide on the application of information</li> </ul>
--	--	---	---

Source: Authors' construct based on literature review

been created as part of the setup enabling the provision of information on nutrition, weather information, and market prices for eight regions in Ghana: Eastern, Western, Ashanti, Central, Northern, Volta, Brong-Ahafo, and Greater Accra (Aker et al. 2018). Vodafone has partnered with ESOKO whereby subscribers to the Vodafone network are connected to input suppliers, aggregators, extension services, and other value chain actors (Nyarko et al. 2013; Duncombe 2016).

Social media platforms such as YouTube, WhatsApp, and Facebook play a role in the delivery of CIS by GMet. YouTube video showcases a 2-minute video on nationwide weather forecasts. On GMet's Facebook page, there are flyers of impending weather conditions for the day or the bulletins to provide an outlook for changes in weather conditions on specific days. The role of WhatsApp is to provide a real-time forecast on an impending storm spotted on satellite images. At the onset of the rainy season, GMet also disseminates its seasonal forecast through YouTube or Twitter.

The website is another channel for the delivery of CIS but mostly it is not tailored for farming. Websites provide general CIS to the public on how to prepare for the dry season or impending floods (Anuga et al. 2019). For instance, during the minor season in 2019, GMet used its website to provide an overview of the weather conditions for the seasons.

Concerning print media such as the newspaper and seasonal forecast bulletins, information on the weather forecasts is communicated via state-owned electronic media and published bulletins from Ghana Media Association (GMA), Ghana News Agency, and the *Daily Graphic*. Some of the outlooks for the rainy season are also published in newspapers (e.g., *daily graphic*), and it is usually at the onset of the main season.

Intermediary platform is also used for the provision of CIS for farming. Intermediary platform consist of farmer audio library, IVR where a farmer can call a specific toll-free line and is taken through the procedures for the desired CIS in their local languages, and agricultural extension agents or field agents who are also equipped with smartphones or tablets to provide a two-way information. It also consists of a call center equipped with agents and a special telephone number (MEAS 2012, Agyekumhene et al. 2018; Munthali et al. 2018; Slavova and Karanasios 2018). With intermediary platforms, field agents or agricultural extension agents serve as mediators between the ICT platforms and farmers. These intermediaries ("infomediaries") may reside within the farming communities, access information on behalf of farmers, and discuss it with them. In some of the case studies, intermediaries are lead farmers and community knowledge brokers. Examples of intermediary platforms include ESOKO, e-agricultural platform, Smartex, and GeoFarmer (Munthali et al. 2018; Quaye et al. 2017).

### Old ICTs

Despite being conventional, old ICTs are also applied in innovative ways to suit the needs of rural farming communities, especially where the use of old ICTs dominates and is intertwined with the social networks and institutional logic of farmers. This contributes significantly to enhancing the spread of information in the farming

communities (Duncombe 2016). The chapter captured the nuanced interplay of innovation with old ICTs.

Radio is one of the conventional digital means of communication that is still relevant in the delivery of CIS to farmers in Ghana (Sam and Dzandu 2016; Nyantakyi-Frimpong 2019b). The use of radio is popular in CIS delivery for several reasons (see Table 1). Community radios, such as Simli Radio at Dalung and Radio Ada at Big Ada, create interactive programs which feature community discussions, interviews, live panel discussions, and call-in shows in local languages. CIS is broadcasted on community radios at specific days in the week when farmers are available, and special signature tunes to draw the attention of listeners (Asenso-Okyere and Mekonnen 2012; Chapman et al. 2003; Nyamekye 2020). Programs are designed and periodically updated throughout the year in response to the types of CIS and agricultural information that are needed (Perkins et al. 2015). Sometimes, farmers are consulted directly during radio programs for relevant data on local indicators for the onset of the season, and comparisons are made with a scientific forecast in a panel discussion to further interpret information (Sam and Dzandu 2016). At a point in the programs, listeners are permitted to call in to interact with panelists, ask questions, and share problems and experiences. At times drama and pre-recorded programs are aired when a panel discussion is not carried out. Commercial radios also provide CIS (Chudaska 2018; Slavova and Karanasios 2018; Nyamekye 2020).

Government- and private-based television channels are other means through which farmers receive CIS, for example, GTV and TV3 (Adjin-Tettey 2013; Anuga et al. 2019). A study also indicated that some farmers also obtain weather forecasts from international television stations such as Aljazeera, CNN, and BBC (Chudaska 2018).

Informal CIS delivery channels have been shown to be preferred by farmers due to oral communication and personal conversation that are mostly practiced in farming communities (Drafor and Atta-Agyepong 2005; Drafor 2016). Farmers still prefer CIS to be delivered by agricultural extension agents, workshops, village knowledge centers, and mobile vans and pamphlets produced by NGOs (Nyantakyi-Frimpong 2019b). Traditional information mediums like drums, loudspeakers, public address systems, gong-gong beaters, town criers, churches, and the loudspeakers of mosques are still relevant (Padgham et al. 2013; Drafor 2016). Others include CIS delivery through Ghana Information Services Department's mobile vans (Anuga and Gordon 2016; Slavova and Karanasios 2018). The information received by farmers is then communicated to others in the farming community. In some communities, CIS is displayed on notice boards, while farmer-to-farmer or farmer cooperatives are also used to facilitate information delivery (Anuga et al. 2019).

### **Category of Farmers' Use of CIS Delivered Through ICTs**

CIS is delivered to farmers with different socioeconomic backgrounds: gender, marital status, and level of education. Mostly, men are able to access CIS with a

variety of ICTs than women due to their ability to easily access mobile phones which are the most common new ICTs in rural communities in Ghana (Partey et al. 2019). Women's access to digital tools is limited to radio and mobile phones which are often owned by their husbands. In some cases, women who had no formal education rely on local knowledge (Chaudhury et al. 2012; Partey et al. 2019). Despite women's use of the radio as the main ICT channel to receive CIS, they are unable to access regular information due to their engagement in numerous household activities. Apart from the ownership of the ICTs, men have a higher capacity to use and operate ICTs especially the mobile phone than women without relying on others for assistance (McOmber et al. 2013). This is attributed to the level of education between men and women (Nyantakyi-Frimpong 2019b). The usage of mobile phones is limited to simple handsets with the exception of a few educated and young farmers. Young people (20–29 years) use new ICTs such as smartphones, apps, and social media. Hence, they are able to access CIS with all forms of ICTs. Within the category of men, young male farmers mostly received SMS and IVR (Partey et al. 2020).

Mostly, the beneficiaries of the CIS-funded projects select a household member or recognized owner of household land to access the information with the assumption that they would share the information with other members of their household (Mohammed 2018). With the application of such criteria, women do not access the information directly (Anaglo et al. 2014; Nyantakyi-Frimpong 2019a). Most women are unable to access CIS with ICTs because of the domination of patriarchal norms which promotes access and control of productive resources as well as decision-making authority by men (Nyantakyi-Frimpong 2019a). Even if women are selected to receive CIS with digital tools, the application of the criteria “one member per household” results in the selection of an adult woman. This implies that within polygamous households where seniority is a norm, it is the elderly women who gain access to CIS.

The frequency of receipt of CIS delivered through ICTs range from daily, 48 h, 5 days, weekly, and monthly forecast. However, there are instances when lots of pending or unopened messages are seen on farmers' phones, and they wait until their literate relatives are around (Mohammed 2018). The reason for this is attributed to low levels of literacy or inability to manipulate the phone (Alemna and Sam 2006). The reliance on relatives who own ICTs to access CIS remains a challenge since their absence could mean the inability to receive information.

Farmers have different types of information needs during each stage of the farming season, and ICTs are used to meet these needs. Seasonal forecasts are CIS provided to farmers at the onset of the farming season with interactive platforms, such as radio and call center. They come with advice on how much rain to expect, the length of the season, and the onset dates (Gbetibouo et al. 2017; Nyantakyi-Frimpong 2019a). Additionally, SMS, IVR, bulletins, social media, websites, and print media are also used to provide seasonal forecasts to support farmers' decision-making on the selection of a variety of (specific) crops.

During the farming seasons, the provisions of local content- and location-specific forecast with the IVR and SMS are mostly used. Also, the weather influences crop pest and disease conditions during the farming seasons; therefore, intermediary



platforms such as call centers are used by farmers to generate information on the application of agrochemicals (Munthali et al. 2018). Some CIS have a short-term lifespan in terms of relevance to decision-making and therefore must be delivered within an appropriate timescale to farmers (daily up to 7 days) with different forms of ICTs (Zougmore et al. 2018). In this regard, the intensity of the rains and the number of rainy days require the provision of daily forecasts with SMS, IVR, and radio to enable decision-making on when to weed and conduct other fieldwork (Partey et al. 2020). When floods or dry spell conditions are expected to occur, radio, SMS, social media, and intermediary platforms are used as the main channels to deliver outlook for the day or week (Stigter et al. 2013). Besides, ICTs help to contextualize CIS and integrate it into farmers' own schemes of experiences (Leeuwis 2004). Some of these CIS include information on the availability of transport and tractor services, credit options, input and market prices, and crop insurance during the farming season (Adiku et al. 2017; Anuga et al. 2019). For instance, the Vodaphone farmer club SMS provides a holistic CIS such as weather information, market prices, costs and availability of inputs (seed and fertilizer), and pest recommendations (Usher et al. 2018; ESOKO 2020). At the end of the farming season, SMS, IVR, and other informal channels are prominent means of delivering CIS such as a 10-day forecast for optimum harvesting period and processing of farm produce.

## Type of Information Needed by Different Categories of Farmers

Farmers' information needs are associated with major decision-making for the farming season. The decision-making includes the type of crop and the variety of seed to select, land size and the number of farmland to cultivate, when to plough, when to sow seeds, when to transplant seedlings, when to do irrigation, when to apply fertilizer and(or) agrochemicals, and when to start harvesting, marketing, and processing (Sarku et al. 2020).

The scant literature on CIS indicates that gender plays a role in the information needs of different categories of farmers. Men have more CIS informational needs to mitigate climate risk compared to women. This is due to differences in preferences and vulnerabilities to climate-related risks, access to farm resources, land ownership, access to labor, access to information, and financial resources (McOmber et al. 2013). Jost et al. (2016) also indicated that limited access to finance, extension services, and farm resources affected women CIS needs. Furthermore, access to a mobile phone, access to irrigation, type of crop produce, and land ownership were influential in determining whether or not someone will use CIS (Partey et al. 2020). Table 2 shows an overview of the information needs for categories of farmers.

The first key decision for the farming season in relation to the application of CIS is the type of crop and the related variables that need to be cultivated. In most households, this decision is the responsibility of household heads who are mostly men. In some contexts, the household head and spouse (or spouses if polygamous) discuss privately and communicate with the rest of the family (Nyamekye 2020).

**Table 2** Information needs of categories of farmers

Type of forecasts	Information needs	Categories of farmers			
		Young men	Young women	Elderly men	Elderly women
Seasonal forecast	Type of crop and the variety of seed to select			✓	✓
	Land size and number of farmland to cultivate			✓	✓
	When to plough	✓	✓		
Daily-weekly forecast	Sowing of seeds or transplanting of seedlings	✓		✓	
	When to apply fertilizer and other agrochemicals	✓		✓	
	When to weed	✓	✓	✓	✓
	When to start harvesting	✓	✓	✓	✓
	Marketing and processing				✓
Legend	✓	Applicable to specific category of farmers			

Source: Authors' construct based on literature review

This implies that young men's and women's information need concerning CIS is mostly dependent on the household heads (Nyantakyi-Frimpong 2019b).

Once farmers decide on the type and variety of crop(s) to cultivate, the next information needs is a forecast on the onset of the rainfall. This information is required to decide on when to prepare the land. Since land is usually prepared when soil moisture is assumed to be high, arrangement for land preparation with a tractor or manual labor becomes the responsibility of the male in the farming household (Chudaska 2018; Partey et al. 2020).

Sowing of seeds or transplanting of seedlings is carried by all categories of farmers after a rainfall. With this practice, CIS is needed by all categories of farmers. Additionally, men usually carry out the application of agrochemicals (e.g., application of fertilizer, weedicides, pesticides, and insecticides). Considering the cost of farm inputs and the availability of labor, CIS is needed by all categories of farmers to decide on when to apply agrochemicals (Sarku et al. 2020). The provision of a forecast on the amount or frequency of rainfall for the farming season is also required by all categories of farmers since it enables them to make arrangements for labor to augment household effort (Nyamekye 2020).

The study deduced that women's information needs to follow the same pattern as men yet it is tied to their relationship with men due to the unavailability of resources at their disposal. In instances where women are in charge of a household and need to take decisions concerning when to start farming, they often consult the men in the household or experienced male farmers in the communities (Nyantakyi-Frimpong 2019a, b). In some cases, women more often than not expect their husbands to provide them with information or determine the various aspect of the decisions for the farming season even when they operate different farms due to their husband's control over the household (Etwire et al. 2017; Partey et al. 2020). This finding adds

evidence to support the growing call for the provision of CIS with ICTs which suit the needs of different categories of farmers.

## **Financing and Governance Arrangement for the Delivery of CIS with Digital Tools**

CIS is a public good that can be accessible to all farmers to enable them to adapt to changing weather and climatic conditions. Yet the application of digital tools for the delivery of CIS has several costs associated with data collections, weather models, Internet data, and telecommunication networks. Therefore, CIS delivery in Ghana comes in the form of quasi-public good with some excludability as users pay for CIS to enable the recovery of cost (Naab et al. 2019). The cost of CIS delivery with ICTs brings to the fore discussions on farmers' willingness to pay for CIS delivered through ICTs (Quaye et al. 2017).

In this regard, two patterns can be identified: First, the majority of smallholder farmers recognize that the provision of CIS is a public good with the responsibility of the government to provide such services. Farmers who rely on free CIS delivered through the radio or television do not have access to tailored information, or they rely on their local knowledge in predicting the weather for farming (Nyantakyi-Frimpong 2013; Naab et al. 2019). Second, some farmers are willing to pay for CIS delivered through ICTs but within a minimum range (Acquah and Onumah 2011; Nantui et al. 2014). These categories of farmers have some socioeconomic characteristics such as age, sex, farm size, on-farm income, membership of a farmer-based organization, literacy level, productivity of crops in a particular season, and perception of climate change experience. Ownership and ability to use ICTs also influence farmers' decision to pay for seasonal CIS. Some studies have, however, indicated that male household heads are more willing to pay for CIS delivered through ICTs. Hence, farmers' willingness to pay for CIS delivered through ICTs is mixed and inconsistent (Adjabui 2018; Ibrahim et al. 2019). The financing mechanisms for the delivery of CIS by an organization involve several options as indicated in Table 3.

Linked to the financing model is the governance model which backs the provision of CIS with ICTs to farmers in Ghana. Although the governance model is not codified due to the absence of a CIS policy in Ghana (Naab et al. 2019), different governance modes are used for CIS delivery to farmers.

### **Donor or NGO Governance Approach**

International donor agencies or organizations establish agricultural projects within specific agroecological zones for farmers. Some projects may be specific toward the provision of CIS, while others have different objectives (Asuru 2017). Numerous donor agencies or NGOs are operating with this governance model, and the provision of an exhaustive list is beyond the scope of this chapter. Few notable ones include ACDI/VOCA, TechnoServe, World Vision, FAO (Food and Agricultural Organization), USAID, Deutsche Gesellschaft für Internationale Zusammenarbeit (GIZ), International Fund for Agricultural Development (IFAD), CARE

**Table 3** Financing of CIS with ICTs to farmers in Ghana

Category of CIS financiers	Funding mechanism
Government financing	Free provision by GMet and GTV through tax and sometimes product levies
Financing by agri-input companies, e.g., Wienco Ghana Limited	Provides embedded services by including the cost of CIS as part of the cost of the product
Commercial output buyers	Makes CIS freely available but incorporates the cost as part of the contract farming
Farmer-based associations, e.g., Cocolink	Membership fees, donor subsidies, government subsidies, and contracts
Direct payment	Direct fees paid through farmers' call credit or airtime, e.g., Esoko
Funded projects	Donor contracts information providers to deliver CIS freely to target groups of farmers
Contract sale	Farmers' subscription is paid by insurance companies or agribusinesses
Business advertisement on CIS platforms	Advertisement of agricultural products linked to the provision of CIS
Minimum payment under public-private partnership	Subsidized payment is made by farmers under a project compared to those who are not part of any project

Source: Based on authors' literature review

International, OXFAM, and the Department for International Development (DfID) (McNamara et al. 2014). These NGOs partner mostly with market-led ICT platform information providers such as ESOKO, MFarm, Ignitia, Farmerline, and others to provide CIS to farmers. Examples include ADVANCE II, Smartex, African Cashew Initiative, and Farm Radio International's African Farm Radio Research Initiative. These projects mainly focused on specific areas such as the Guinea and Sudan savanna agroecological zone of Ghana due to the presence of donor activities in these areas (Naab et al. 2019).

### Public-Private Partnership

The use of digital tools for the provision of CIS results in an interconnected network of activities between smallholder farmers and actors providing and mediating the process leading to the formation of public-private partnerships (PPP). The PPP governance mode of providing CIS for farmers involves NGOs, public sectors, mobile network telecommunication providers, market-led ICT platform information providers, and climate/weather model or satellite providers together with farming communities (Partey et al. 2019). With these arrangements, each actor provides certain resources for CIS delivery. Examples of PPP in the provision of CIS with ICTs include the CGIAR Research Programme on Climate Change, Agriculture and Food Security (CAAFS); businesses such as ESOKO, Vodafone, and Toto agric and aWhere; and public organizations that collaborate with GMet, the Council for Scientific and Industrial Research (CSIR), and MoFA to provide CIS to some

farmers in the Upper West region under the Planting for Food and Jobs programs (Etwire et al. 2017; Partey et al. 2019, 2020).

### **Participatory or Co-production Approaches**

ICTs enable cross production of knowledge from different sectors of society (Karpouzoglou et al. 2016; Vogel et al. 2019). In Ghana, ICTs are enabling this process through co-production of CIS with farmers' local knowledge and that of scientists. In some cases, farmers collect data on their local weather indicators, or they contribute their knowledge in several ways (Nyadzi 2020; Sarku et al., [forthcoming](#)). For example, Participatory Integrated Climate Services for Agriculture (PICSA) is an approach that has involved over 5000 farmers in Northern Ghana by using both historical climate information and forecasts to support farmers' decision-making with participatory decision-making tools that suit their contexts (Etwire et al. 2017; Clarkson et al. 2019).

### **Farmer Organization Provision**

Another governance approach is the provision of CIS by producer cooperatives/associations. These organizations deliver CIS to farmers in the group. Payment for the CIS is drawn from the coffers of the association or through donor support. Examples of such governance models are used by Kuapa Kokoo cooperatives, the Africa Cashew Initiative, and Cocolink (MEAS 2012).

### **Business Model**

Business companies use a wide variety of business models to deliver CIS, and no single model is dominant. Six different business models were identified:

- Business-to-business-to farmer model, e.g., Esoko.
- Business-to-business-to-consumer model is used between market-led ICT platform information providers (Ignitia), mobile telecommunication networks (MTN Ghana), and farmers (Chudaska 2018). Another example is farmers on the ADVANCE II project who are connected to MTN Ghana which runs the promotion sale of simple mobile phones to enable farmers to receive CIS (Mohammed 2018).
- Direct services to farmers, e.g., Vodafone farmer club where farmers pay US\$ 0.20 per month as a direct debit from their call credits to receive CIS. Subscribers also receive free airtime to call members of the group (Partey et al. 2019, 2020).
- Business to nucleus farmer and outgrower schemes is an approach that is becoming common where CIS is provided as an embedded service model. In this approach, agri-input companies, in particular, provide information about farm inputs, and CIS is added as a package. The cost of the CIS is embedded as an unidentified component of the sales price. An example of this governance approach is used by the USAID-funded ADVANCE project to promote the use of input supplies, improved seeds, and CIS (MEAS 2012; Mohammed 2018). Wienco Ghana also provides CIS with this model in the areas of cash and food

crops for both small- and large-scale farmers in the agricultural value chain (Naab et al. 2019).

Informal governance approach for the provision of CIS includes traditional institutional arrangement used by farming communities. These are in the form of rules or norms that the farming community adheres to (Slavova and Karanasios 2018).

---

## Discussion of Emerging Issues

First, informal channels of information delivery still hold prominence among smallholder farmers as a means for interaction. For instance, the provision of CIS by agricultural extension agents, workshops, participatory approaches, and the use of social networks are still prominent (Nyantakyi-Frimpong 2019a). Furthermore, information sources in farming communities are often embodied in knowledgeable people and shared through interactions occurring at the market, religious meetings, bus stops, community centers, and other places of meetings. Most often, the CIS is received by one person in the community, and it is shared with other members of the farming community (Kirbyshire and Wilkinson 2018). This has implications on credibility, trust, and sustainability of financial models of actors who provide CIS through ICTs. Due to the need for interactions among smallholder farmers, preferences for ICTs for the delivery of CIS still hinge on interactive technologies which provide an opportunity for farmers to ask questions and share their experiences. This suggests the need to support innovations on the use of interactive ICTs for the delivery of CIS.

Despite the limited use of new ICTs among farmers, mobile phones, in particular, have helped farmers to communicate CIS to other farmers, thereby enhancing interactions and reinforcing interpersonal relationships and norms of openness among farmers. First, mobile phones strengthened bonds in the rural community by enabling information exchanges between family, farmers, and intermediaries. Second, mobile phones complement informal ways of communicating among farmers. Therefore, norms of openness, inclusiveness, and information-sharing are strengthened rather than challenged. The findings suggest that the informal and formal channels of CIS delivery support smallholder farming institutional logic than ICTs destroying informal institutions.

Additionally, intermediaries who provide CIS with ICTs are able to exploit complementarities among digital tools and informal channels of communication. They are able to fuse characteristics and logics of informal communication channels with ICTs such as call center, IVR, and radios which relate to established patterns of interaction among smallholder farmers. The use of mobile phones, SMS alert, or peep call during radio programs is also an example. The combination of informal and ICTs helps to increase farmers' access to CIS.

Despite the evolution of sophisticated ICTs, the provision of CIS with ICTs is limited to simple ones like mobile phones, radio, and television. Thus, farmers rarely

use social media, weather apps, and websites to receive useful CIS. Some farmers are unable to operate the phone without the assistance of relatives. This leaves the potentials of ICTs untapped for the delivery of CIS, or it results in the use of platform intermediaries. These challenges are attributed to increased sophistication of ICTs without being tailored for local farmers with literate and visual challenges and limited training on the use of ICTs (Alemna and Sam 2006; Sarku et al. [forthcoming](#)). The unavailability of local content ICTs also affects its usage as technologies are originally coded in English. In addition, many languages in Ghana use characters that are not found on the keyboards of most ICTs. Furthermore, the provision of CIS for the target group requires specific local content which affects the scalability of CIS to other agroecological locations in Ghana. There are issues regarding the affordability of ICTs such as smartphones, expensive call charges, and data (Partey et al. 2020; Etwire et al. 2017). All these challenges have implications on information asymmetry as some farmers can use ICT and access tailored CIS, while others still rely on their local knowledge for forecasting.

Findings in this chapter show that the delivery of CIS with ICT platforms are mostly piloted or funded by donors. At the end of the project, farmers are expected to subscribe to continue to receive information at a fee. However, their willingness to pay for the information raises questions about the continuity of CIS delivery. Many of the projects are designed with a top-down approach, without collaborations from farmers at the implementation stage. This raises questions on upscaling from pilot projects to larger farming communities. A limitation of relying on donors to fund the delivery of CIS with ICTs is that specific agroecological zones are targeted for a short period (McNamara et al. 2014). This affects the number of farmers who are reached within the specified period. Since climate change and variability impacts are experienced differently in specific agroecological zones in Ghana, it will be important to have nationwide CIS tailored for all farmers.

---

## Conclusion

This chapter examined the delivery of CIS with digital tools to smallholder farmers by reviewing existing literature on the sector. Overall, our rapid scoping assessment found very positive results on the use of various digital tools for the collection, processing, and delivery of CIS to farmers. The delivery of CIS with ICTs was used mostly by men and during the farming season; a variety of ICTs are used to deliver CIS due to the level of demand for information. Old technologies, like radio, remain the most relevant and cost-efficient ICT platforms for the delivery of CIS. Some ICTs remain underused by farmers calling for the role of ICT platform intermediaries like agricultural extension agents and field agents. The delivery of CIS with ICTs results in changes in institutional logics in farming communities in the form of new interactions, information exchange, and other forms of innovation intermediation. Overall, informal information delivery channels coexist with ICT modes and are sometimes blended in various ways to provide CIS. The analysis in this chapter provides a coherent overview on the application of digital tools for the delivery of

CIS for smallholder farming in Ghana. The emerging issues identified in the literature have contributed to the identification of areas for future research. These include (1) exploration of appropriate financial models for the sustainability and scalability of CIS delivery with ICTs; (2) application of ICTs for the delivery of CIS for other value chain actors such as processors, transporters, and aggregators; (3) increase research on how ICTs are used for data collection and production at the community level; and (4) assessment of the quality of CIS provided to smallholders.

## References

- Acquah HG, Onumah EE (2011) Farmers perception and adaptation to climate change: an estimation of willingness to pay. *Agris On-line Papers Econ Inform* 3(4):31–39
- Adiku SG, Debrah-Afanyede E, Greatrex H, Zougmore RB, MacCarthy DS (2017) Weather-index based crop insurance as a social adaptation to climate change and variability in the Upper West Region of Ghana. Working paper no 189. CGIAR Research Program on Climate Change, Agriculture and Food Security, Copenhagen
- Adjabui JA (2018) Farmers' willingness to participate and pay for, and agricultural extension officers' disposition to communicate weather index-based insurance scheme in Ghana: the case of the upper east region. Master thesis, Massey University
- Adjin-Tettey TD (2013) The perception and usage of weather forecast information by residents of African concrete products (ACP) estates and farmers in selected communities around Pokuase in the Ga west municipality of Ghana. *Int J ICT Manage I*(3), 139–149.
- Agyekumhene C, de Vries JR, van Paassen A, Macnaghten P, Schut M, Bregt A (2018) Digital platforms for smallholder credit access: the mediation of trust for cooperation in maize value chain financing. *Wagening Journal of Life Sciences*, 86–87, 77–88. <https://doi.org/10.1016/j.njas.2018.06.001>
- Aker JC (2011) Dial “A” for agriculture: a review of information and communication technologies for agricultural extension in developing countries. *Agric Econ* 42:631–647
- Aker PG, Gilligan J, Hidrobo DM, Ledlie N (2018) Paying for digital information: assessing farmers' willingness to pay for a digital agriculture and nutrition service in Ghana Other area references. In: 30th International conference of agricultural economist
- Akudbillah NA (2017) Modelling the socio-economic benefits of the adoption of climate information: an innovative approach to subsistence farmer adaptation to climate change in Garu-Tempene District, Ghana. Master's thesis, University of Bergen
- Akudugu MA, Guo E, Dadzie SK (2012) Adoption of modern agricultural production technologies by farm households in Ghana: what factors influence their decisions. *J Biol Agric Healthc* 2(3). Retrieved from <https://www.iiste.org/Journals/index.php/JBAH/article/view/1522>
- Alemna AA, Sam J (2006) Critical issues in information and communication technologies in Ghana. *Inform Dev* 22(4). <https://doi.org/10.1177/0266666906074181>
- Alhassan RM, Egyir IS, Abakah J (2013) Farm household level impacts of information communication technology (ICT)-based agricultural market information in Ghana. *J Dev Agric Econ* 30(5):161–167
- Anaglo JN, Boateng SD, Boateng CA (2014) Gender and access to agricultural resources by smallholder farmers in the upper west region of Ghana. *J Educ Pract* 5(5). <http://www.iiste.org>
- Anuga SW, Gordon C (2016) Adoption of climate-smart weather practices among smallholder food crop farmers in the Techiman municipal: implication for crop yield. *Res J Agric Environ Manage* 5(9):279–286
- Anuga SW, Gordon C, Boon E, Musah-Issah JS (2019) Determinants of climate smart agriculture (CSA) adoption among smallholder food crop farmers in the Techiman municipality, Ghana. *J Geogr* 11(1):124–139. <https://doi.org/10.4314/gjg.v11i1.8>
- Asenso-Okyere K, Mekonnen DA (2012) The importance of ICTs in the provision of information for improving agricultural productivity and rural incomes in Africa. Working Paper 2012–



015. United Nations Development Programme's Regional Bureau for Africa, Addis Ababa. Available at <http://web.undp.org/africa/knowledge/WP-2012-015-okyere-mekonnen-ict-productivity.pdf>
- Asuru S (2017) The new philanthropy and smallholder farmers' livelihoods. A case study of the Alliance for a Green Revolution in Africa (AGRA) in the northern region of Ghana. Doctoral thesis, University of Bradford
- Barber J, Mangnus E, Bitzer V (2016) Harnessing ICT for agricultural extension. KIT working paper 4. Amsterdam. Accessed from [https://www.kit.nl/wp-content/uploads/2019/10/KIT\\_WP2016-4\\_Harnessing-ICT-for-agricultural-extension.pdf](https://www.kit.nl/wp-content/uploads/2019/10/KIT_WP2016-4_Harnessing-ICT-for-agricultural-extension.pdf)
- Bell M (2015) Information and communication technologies for agricultural extension and advisory services. ICT-powering behavior change for a brighter agricultural future. MEAS Project, Urbana
- Bennett WL, Segerberg A (2012) The logic of connective action: digital media and the personalization of contentious politics, information. *Commun Soc* 15:739–768. <https://doi.org/10.1080/1369118X.2012.670661>
- Buytaert W, Zulkafli Z, Grainger S, Acosta L, Alemie TC, Bastiaensen J et al (2014) Citizen science in hydrology and water resources: opportunities for knowledge generation, ecosystem service management, and sustainable development. *J Front Earth Sci* 2:1–21. <https://doi.org/10.3389/feart.2014.00026>
- Caine A, Dorward P, Clarkson G, Evans N, Canales C, Stern D (2015) Review of mobile applications that involve the use of weather and climate information: their use and potential for Smallholder Farmers. CCAFS working paper no150. CGIAR Research Program on Climate Change, Agriculture and Food Security (CCAFS), Copenhagen. Available online at: <http://www.ccafs.cgiar.org>
- Chapman R, Blench R, Kranjac-Berisavljevic G, Zakariah ABT (2003) Rural radio in agricultural extension: the example of vernacular radio programmes on soil and water conservation in Ghana. Network paper no 127. Overseas Development Institute, London
- Chaudhury M, Kristjanson P, Kyagazze F, Naab JB, Neelormi S (2012) Participatory gender-sensitive approaches for addressing key climate change-related research issues: evidence from Bangladesh, Ghana, and Uganda. Working paper 19. CGIAR Research Program on Climate Change, Agriculture and Food Security (CCAFS), Copenhagen
- Chudaska R (2018) Informational governance: exploring how the flow of water-related information affects farming practices and decision-making in Ada east. Master thesis, Wageningen University
- Cieslik K, Leeuwis C, Dewulf A, Feindt P, Lie R, Werners S et al (2018) Addressing socio-ecological development challenges in the digital age: environmental virtual observatories for connective action. *NJAS Wagening J Life Sci* 86–87:2–11
- Clarkson G, Dorward P, Osbahra H, Torgbor F, Kankam-Boadu I (2019) An investigation of the effects of PICSA on smallholder farmers' decision making and livelihoods when implemented at large scale—the case of northern Ghana. *Clim Serv* 14:1–14
- Dilling L, Lemos MC (2011) Creating usable science: opportunities and constraints for climate knowledge use and their implications for science policy. *Glob Environ Chang* 21:680–689
- Dinku T, Thomson MC, Cousin R, del Corral J, Ceccato P, Hansen J, Connor SJ (2018) Enhancing national climate services (ENACTS) for development in Africa. *Clim Dev* 10(7):664–672. <https://doi.org/10.1080/17565529.2017.1405784>
- Dougill AJ, Whit S, Stringer LC, Vincent K, Wood BT, Chinseu EL et al (2017) Mainstreaming conservation agriculture in Malawi: knowledge gaps and institutional barriers, 195. <https://doi.org/10.1016/j.jenvman.2016.09.076>
- Drafor I (2016) Access to information for farm-level decision-making. *J Agric Food Inf* 17(4):230–245. <https://doi.org/10.1080/10496505.2016.1213170>
- Drafor I, Atta-Agyepong K (2005) Local information systems for community development in Ghana. In: Dixon J, Wattenbach H, Bishop-Sambrook C (eds) *Improving information flows to the rural community*. FAO, Rome, pp 5–19
- Dumenu WK, Obeng EA (2016) Climate change and rural communities in Ghana: social vulnerability, impacts, adaptations and policy implications. *Environ Sci Policy* 55:208–217. <https://doi.org/10.1016/j.envsci.2015.10.010>

- Duncombe R (2016) Mobile phones for agricultural and rural development: a literature review and suggestions for future research. *Eur J Dev Res* 28:213–235. <https://doi.org/10.1057/ejdr.2014.60>
- Eitzinger A, Cocka J, Atzmanstorfer K, Binder CR, Läderach P, Bonilla-Findjia O, Bartling M, Mwongeraa C, Zuritae L, Jarvisa A (2019) GeoFarmer: a monitoring and feedback system for agricultural development projects. *Comput Electron Agric* 158:109–121
- Etwire PM, Buah S, Ouédraogo M, Zougmore R, Partey ST, Martey E, Djibril SD, Bayala J (2017) An assessment of mobile phone-based dissemination of weather and market information in the Upper West Region of Ghana. *J Agric Food Secur* 6:8. <https://doi.org/10.1186/s40066-016-0088-y>
- Federspiel S (2013) Climate change adaptation planning, implementation and evaluation: needs, resources and lessons for the 2013 National Climate Assessment. University of Michigan School of Natural Resources and Environment, Ann Arbor
- Gbetibouo G, Hill C, Abazaami J, Mills A, Snyman D, Huyser O (2017) Impact assessment on climate information services for community-based adaptation to climate change: Ghana country report. CARE international adaptation learning program, Ghana. <http://careclimatechange.org/wp->
- Gotamey A, Shankar A, Toomasson T (2018) Rain forecasting service for rural Ghana implementation prototype report. ICT4D: Information and Communication Technology for Development (X\_405101), Amsterdam
- Graham R, Visman E, Wade S, Amato R, Bain C, Janes T, Leathes B, Lumbroso D, Cornforth R, Boyd E, Parker D (2015) Scoping, options analysis and design of a ‘Climate Information and Services Programme’ for Africa (CIASA). *Lit Rev*. [https://doi.org/10.12774/eod\\_cr.may2015.grahamr](https://doi.org/10.12774/eod_cr.may2015.grahamr)
- Hansen JW, Vaughan C, Kagabo DM, Dinku T, Carr ER, Körner J, Zougmore RB (2019) Climate services can support African Farmers’ context-specific adaptation needs at scale. *Front Sustain Food Syst* 3(21). <https://doi.org/10.3389/fsufs.2019.00021>
- Ibrahim N, Teye MK, Alhassan H, Adzawla W, Adjei-Mensah C (2019) Analysis of smallholder farmers’ perceptions on climate change, preference and willingness-to-pay for seasonal climate forecasts information in Savelugu Municipality, Ghana. *Asian J Environ Ecol* 9(1):1–11, Article no.AJEE.47872 ISSN: 2456-690X
- IPCC (2014) Climate change 2014: impacts, adaptation, and vulnerability. Part A: global and sectoral aspects. In: Field CB, Barros VR, Dokken DJ, Mach KJ, Mastrandrea MD, Bilir TE, Chatterjee M, Ebi KL, Estrada YO, Genova RC, Girma B, Kissel ES, Levy AN, MacCracken S, Mastrandrea PR, White LL (eds) Contribution of working group II to the fifth assessment report of the Intergovernmental Panel on Climate Change. Cambridge University Press, Cambridge, UK/New York, 1132 pp
- Just C, Kyazze F, Naab J, Neelormi S, Kinyangi J, Zougmore R et al (2016) Understanding gender dimensions of agriculture and climate change in smallholder farming communities. *J Clim Dev* 8:133–144
- Kadi M, Njau LN, Mwikya J, Kamga A (2011) The state of climate information services for agriculture and food security in West African Countries. CCAFS working paper no 4. Copenhagen. Available online at: <http://www.ccafs.cgiar.org>
- Karpouzoglou T, Zulkafli Z, Grainger S, Dewulf A, Buytaert W, Hannah DM (2016) Environmental virtual observatories (EVOs): prospects for knowledge co-creation and resilience in the information age. *Curr Opin Environ Sustain* 18:40–48. <https://doi.org/10.1016/j.cosust.2015.07.015>
- Kirbyshire A, Wilkinson E (2018) Challenging assumptions: What impact are NGOs having on the wider development of climate services? Research, reports and studies. Overseas Development Institute. <https://www.odi.org/sites/odi.org.uk/files/resources-documents/...>
- Leeuwis C (2004) Communication for rural innovation: rethinking agricultural extension. Blackwell Science, Oxford
- Lemos MC, Kirchoff CJ, Ramprasad V (2012) Narrowing the climate information usability gap. *J Clim Change* 2(11):789–794

- Materia VC, Giarè F, Klerkx L (2015) Increasing knowledge flows between the agricultural research and advisory system in Italy: combining virtual and non-virtual interaction in communities of practice. *J Agric Educ Ext* 21:203–218. <https://doi.org/10.1080/1389224X.2014.928226>
- McNamara P, Dale J, Keane J, Ferguson O (2014) Strengthening pluralistic agricultural extension in Ghana: a MEAS Rapid Scoping Mission, Accra. Modernizing extension and advisory services discussion paper. USAID, Illinois.
- McOmber C, Panikowski A, McKune S, Bartels W, Russo S (2013) Investigating climate information services through a gendered lens. CCAFS working paper no 42. CGIAR Research Program on Climate Change, Agriculture and Food Security (CCAFS). Copenhagen. Available online at: <http://www.ccafs.cgiar.org>
- Mills A, Huyser O, van den Pol O, Zoeller K, Snyman D, Tye N, McClure A (2016) UNDP market assessment: revenue generating opportunities through tailored weather information products. UNDP, New York. License: Creative Commons Attribution CC BY 3.0 IGO
- Modernizing Extension and Advisory Services (MEAS) (2012) Rapid appraisal of the ICT for agricultural extension landscape in Ghana. Retrieved from the MEAS website: <http://www.meas-extension.org>
- Mohammed HN (2018) Digital tools and smallholder agriculture: the role of ICT-enabled extension services in rural smallholder farming in northern Ghana. Master of Arts in Development Studies, International Institute of Social Studies
- Mol APJ (2008) Environmental reform in the information age – the contours of informational governance. Cambridge University Press, Cambridge
- Munthali N, Leeuwis C, van Paassen A, Lie R, Asare R, van Lammeren R, Schut M (2018) Innovation intermediation in a digital age: comparing public and private new-ICT platforms for agricultural extension in Ghana. *Wagening J Life Sci* 86–87:64–76
- Naab FZ, Abubakari Z, Ahmed A (2019) The role of climate services in agricultural productivity in Ghana: the perspectives of farmers and institutions. *Clim Serv* 13:24–32
- Nantui F, Nketiah MP, Darko D (2014) Farmers' willingness to pay for weather forecast information in Savelugu-Nanton municipality of the northern region. *RJOAS* 12(36):34
- Nyadzi E (2020) Best of both worlds: co-producing climate services that integrate scientific and indigenous weather and seasonal climate forecast for water management and food production in Ghana. PhD thesis, Wageningen University
- Nyamekye AB (2020) Towards a new generation of climate information systems information systems and actionable knowledge creation for adaptive decision-making in Rice Farming Systems in Ghana. PhD thesis, Wageningen University
- Nyantakyi-Frimpong H (2013) Indigenous knowledge and climate adaptation policy in northern Ghana. The Africa portal background, number 48. Center for International Governance Innovation, Waterloo
- Nyantakyi-Frimpong H (2019a) Unmasking difference: intersectionality and smallholder farmers' vulnerability to climate extremes in Northern Ghana. *Gender Place Cult.* <https://doi.org/10.1080/0966369X.2019.1693344>
- Nyantakyi-Frimpong H (2019b) Combining feminist political ecology and participatory diagramming to study climate information service delivery and knowledge flows among smallholder farmers in northern Ghana. *Appl Geogr* 112:102079
- Nyarko Y, Hildebrandt N, Romagnoli G, Soldani E (2013) Market information systems for rural farmers evaluation of Esoko MIS – year 1 results. Blog Post, Cent Technol Econ Dev NYU. <http://www.nyucted.org/archives/1108>
- Omoine H, Chen HM, Akhtar I (2013) RainCast: a voice based weather service for Rural Ghana. Accessed from <https://w4ra.org/wp-content/uploads/2018/08/Raincast.pdf>
- Padgham J, Devisscher T, Togtokh C, Mtilatila L, Kaimila E, Mansingh I, Agyemang-Yeboah F, Obeng FK (2013) Building shared understanding and capacity for action: insights on climate risk communication from India, Ghana, Malawi, and Mongolia. *Int J Commun* 7:970–983. 1932–8036/20130005. Available at <http://ijoc.org>

- Partey ST, Nikoi GK, Ouédraogo M, Zougmore RB (2019) Scaling up climate information services through public-private partnership business models: an example from northern Ghana. CCAFS Info note. <https://hdl.handle.net/10568/101133>
- Partey ST, Dakorah AD, Zougmore RB, Ouédraogo M, Nyasimi M, Nikoi GK, Huyer S (2020) Gender and climate risk management: evidence of climate information use in Ghana. *Clim Chang*. <https://doi.org/10.1007/s10584-018-2239-6>
- Perkins K, Huggins-Rao S, Hansen J, van Mossel J, Weighton L, Lynagh S (2015) Interactive radio's promising role in climate information services: Farm Radio International concept paper. CCAFS working paper no 156. CGIAR Research Program on Climate Change, Agriculture and Food Security (CCAFS), Copenhagen. Available online at: <http://www.ccafs.cgiar.org>
- Quaye W, Asafu-Adjaye NY, Yeboah A, Osei C, Agbedanu EE (2017) Appraisal of the agro-tech smart extension model in Ghana, payment options and challenges in ICT-enabled extension services delivery. *Int J Agric Educ Ext* 3(2):72–84
- Sam J, Dzandu L (2016) The use of radio to disseminate agricultural information to farmers: the Ghana agricultural information network system (GAINS) experience. *Agric Inf Worldw* 11:17–23
- Sarku R, Dewulf A, Slobbe VE, Termeer K, Kranjac-Berisavljevic G (2020) Adaptive decision-making under conditions of uncertainty: the case of farming in the Volta delta, Ghana. *J Integr Environ Sci* 17(1):1–33. <https://doi.org/10.1080/1943815X.2020.1729207>
- Sarku R, Gbangou T, Dewulf A, Slobbe VE (forthcoming) Beyond 'experts knowledge': locals and experts in a joint production of weather App and weather information for farming in the Volta Delta, Ghana. In: Handbook of climate change management: research, leadership, transformation. Springer, New Delhi
- Singh C, Urquhart P, Kituyi E (2016) From pilots to systems: barriers and enablers to scaling up the use of climate information services in smallholder farming communities. CARIAA working paper no 3. International Development Research Centre/UK Aid, Ottawa/London. Available online at: <http://www.idrc.ca/cariaa>
- Singh C, Daron J, Bazaz A, Ziervogel G, Spear D, Krishnaswamy J, Zaroug M, Kituyi E (2018) The utility of weather and climate information for adaptation decision-making: current uses and future prospects in Africa and India. *Clim Dev* 10(5):389–405. <https://doi.org/10.1080/17565529.2017.1318744>
- Slavova M, Karanasios S (2018) When institutional logics meet information and communication technologies: examining hybrid information practices in Ghana's agriculture. *J Assoc Inf Syst* 19(9):775–812. <https://doi.org/10.17705/1jais.00509>
- Soma K, MacDonald BH, Termeer CJAM, Opdam P (2016) Introduction article: informational governance and environmental sustainability. *J Curr Opin Environ Sustain* 18:131–139. <https://doi.org/10.1016/j.cosust.2015.09.005>
- Stigter K, Winarto YT, Ofori E, Zuma-Netshiukhwi G, Nanja D, Walker S (2013) Extension agrometeorology as the answer to stakeholder realities: response farming and the consequences of climate change. *J Atmos* 4:237–253. <https://doi.org/10.3390/atmos4030237>
- Suchiradipat B, Saravanan R (2016) Social media: shaping the future of agricultural extension and advisory services. GFRAS interest group on ICT4RAS discussion paper. GFRAS, Lindau. Accessed from Social media: Shaping the future of agricultural . . . – GFRAS. <http://www.g-fras.org/knowledge/gfras-publications>
- Sulaiman RV, Hall A, Kalaivani NJ, Dorai K, Reddy TSV (2012) Necessary, but not sufficient: critiquing the role of information and communication technology in putting knowledge into use. *J Agric Educ Ext* 18:331–346. <https://doi.org/10.1080/1389224X.2012.691782>
- Tall A, Hansen J, Jay A, Campbell B, Kinyangi J, Aggarwal PK, Zougmore R (2014) Scaling up climate services for farmers: mission possible. Learning from good practice in Africa and South Asia. CCAFS report no 13. CGIAR Research Program on Climate Change, Agriculture and Food Security (CCAFS), Copenhagen
- Usher J, Phiri C, Linacre N, O'Sullivan R, Qadir U (2018) Climate information Services market assessment and business model review. USAID-supported Assessing Sustainability and Effectiveness of Climate Information Services in Africa Project, Washington, DC

- Vaughan C, Dessai S (2014) Climate services for society: origins, institutional arrangements, and design elements for an evaluation framework. *J Clim Change* 5(5):587–603. <https://doi.org/10.1002/wcc.290>
- Vogel C, Steynor A, Manyuchi A (2019) Climate services in Africa: re-imagining an inclusive, robust and sustainable. *Clim Serv* 15:100107
- World Meteorological Organization (2015) Valuing weather and climate: economic assessment of meteorological and hydrological services. WMO-No 1153. WMO, Geneva
- Zougmore RB, Partey ST, Ouédraogo M, Torquebiau E, Campbell BM (2018) Facing climate variability in sub-Saharan Africa: analysis of climate-smart agriculture opportunities to manage climate-related risks. *Cahiers Agric* 27(3):1–9

## Websites

- CTA, Ghana. <https://www.cta.int/en-GB/search?location=2300660>
- ESOKO (2020). <https://esoko.com/blog/>
- African Cashew initiative (2020). <https://www.comcashew.org/>
- FARM Radio International (2020). <https://farmradio.org/about/>
- Ghana Meteorological Agency (2020). [http://www.rainsat.net/index.html?country=Ghana](https://www.google.nl/search?source=hp&ei=5XZqXvf3JHhWkwWUya34Dg&q=ghana+meteorological+agency&oq=Ghana+meteo&gs_l=psy-Rainsat Ghana. <a href=)
- ACDI/VOCA. <https://www.acdivoca.org/projects/agricultural-development-and-value-chain-enhancement-ii-advance-ii-project/>
- Farmerline. <https://farmerline.co/>
- Cocoalink. [https://cocobod.gh/coco\\_link.php](https://cocobod.gh/coco_link.php)
- Smartex. <https://www.idrc.ca/en/research-in-action/improving-farming-practices-ghana-radio-and-cell-phones>
- PISCA. <https://research.reading.ac.uk/picsa/>

**Open Access** This chapter is licensed under the terms of the Creative Commons Attribution 4.0 International License (<http://creativecommons.org/licenses/by/4.0/>), which permits use, sharing, adaptation, distribution and reproduction in any medium or format, as long as you give appropriate credit to the original author(s) and the source, provide a link to the Creative Commons license and indicate if changes were made.

The images or other third party material in this chapter are included in the chapter's Creative Commons license, unless indicated otherwise in a credit line to the material. If material is not included in the chapter's Creative Commons license and your intended use is not permitted by statutory regulation or exceeds the permitted use, you will need to obtain permission directly from the copyright holder.





# Clean Energy Technology for the Mitigation of Climate Change: African Traditional Myth **62**

Abel Ehimen Airoboman, Patience Ose Airoboman, and Felix Ayemere Airoboman

## Contents

Introduction .....	1280
Clean Cooking Energy and Their Challenges .....	1281
Role of Government During the AET Period .....	1283
The Psychological Myth of Locals .....	1286
A Look at Environmental Ethics .....	1287
The Way Forward .....	1288
Conclusion .....	1290
References .....	1291

## Abstract

The global Anticipated Energy Transition Period (AETP) is one that all stakeholders must embrace with respect to curbing energy poverty, thereby addressing issues related to climate change especially in the sub-Saharan region of Africa. The region is endowed with abundant richer, cleaner, and affordable energy sources, majority of which has remained untapped due to many reasons, one of which is tied to the socio-cultural traditional beliefs and value systems of the

This chapter was previously published non-open access with exclusive rights reserved by the Publisher. It has been changed retrospectively to open access under a CC BY 4.0 license and the copyright holder is “The Author(s)”. For further details, please see the license information at the end of the chapter.

A. E. Airoboman (✉)

Department of Electrical/Electronic Engineering, Nigerian Defence Academy, Kaduna, Nigeria  
e-mail: [airobomanabel@nda.edu.ng](mailto:airobomanabel@nda.edu.ng)

P. O. Airoboman

Department of Biotechnology, Nigerian Defence Academy, Kaduna, Nigeria

F. A. Airoboman

Faculty of Arts, Department of Philosophy, University of Benin, Benin City, Nigeria  
e-mail: [felix.airoboman@uniben.edu](mailto:felix.airoboman@uniben.edu)

© The Author(s) 2021

W. Leal Filho et al. (eds.), *African Handbook of Climate Change Adaptation*,  
[https://doi.org/10.1007/978-3-030-45106-6\\_65](https://doi.org/10.1007/978-3-030-45106-6_65)

1279

citizens. This has forced majority of the inhabitants to continue to rely on the use of non-biodegradable materials for the purpose of cooking and many other activities. This value system, therefore, contributes to have had an adverse effect on the climate and also on the health of the citizens most of whom are women and children residing in rural areas. The outlook on the AETP, their effect on climate change, the use of Clean Energy Technology (CET) domestically, the various strata expected to come with the AETP, the socio-cultural dynamics in terms of acceptability by all (rural, peri-urban, and urban areas) is addressed in this chapter. The chapter concluded by designing a CET model that could assist in planning for the AETP and mitigating climate change.

---

**Keywords**

AET · Africa · CCS · CET · Biofuel · Environment · Morality

---

**Introduction**

Energy plays a vital role in socioeconomic affairs of people, but it must be available in a desired quality and quantity to be able to meet their needs. Only 290 million people out of the 915 million people in sub-Saharan Africa has access to electricity (IEA 2014; Aboua and Toure 2018). It is equally expected that in the years to come, the population in Africa will grow rapidly, and this may cause a major challenge to the international community due to the slow energy penetration it has received over the years. One of the goals of the appropriate authorities in years to come would be to phase out the use of coal and oil in the market due to their harmful effects on the environment, livestock, and people and then replace them with clean energy for residential, commercial, and industrial uses. According to IRENA (2019), the price of solar PV, solar battery, and solar wind has reduced by 70%, 40%, and 25%, respectively, since 2010, and this is an indication that the Clean Energy Technology (CET) is gradually penetrating the market due to reduction in prices and an improvement in the technology. Generally, energy consumption has direct effects on the role of individuals and communities, whether local, urban, or peri-urban. The idea is that energy contributes to the technological, sociocultural, agricultural, educational, as well as psychological standards in a given settlement; thus, it should be accessible, reliable, affordable, and available when needed. One of the technological penetrations as a result of Anticipated Energy Penetration (AEP) would be the use of Clean Energy Stove (CES) for cooking. Energy comes in different forms from either biomass or biogas. Biomass, as an energy source, has been appreciated by people over the years because it is readily available and appears to be cheap. However, it is anticipated by the United Nations that by the year 2040, electricity should be appreciated by people all over the globe as their first choice of energy. This chapter, therefore, looks at the CET during the pre-AET and post-AET period, their effects, and how they would contribute to the sociocultural dynamics of settlements in sub-Saharan Africa and the sustainability of their environment.

## Clean Cooking Energy and Their Challenges

According to WEO (2017), 2.8 billion people across the globe is presently denied access to CET. Majority of them presently reside in Asia and Africa. Similarly, the World Health Organization (WHO) recorded that 7.7% of death rate worldwide is the result of indoor pollution and incomplete combustion; and mostly, women and children are the most vulnerable. One of the contributing factors among others is the inefficient manner in which the solid biomass fuel is used. Furthermore WEO (2017) also affirmed that four out of every five persons in sub-Saharan Africa are yet to appreciate the CET; rather, they prefer the use of solid biomass as fuel, and the effect of this is deforestation, desertization, pollution, erosion, loss of species, global warming, impaired human development, and scarcity of raw materials for other technological purposes. During the AET period, it is expected that solid biomass fuel such as firewood, agricultural residue, coal, animal dung, and generic organic waste would be phased out gradually and replaced with electricity. It is also envisaged that during this period, the choices for other forms of energy other than electricity available across the globe should be reduced drastically because the more the choices are available, the greater the burden in transiting to Clean Cooking Energy (CCE). The advent of the AETP is expected to gradually integrate the CET into the market and this technology will be geared to address inefficiency in cooking methods while speeding up the rate of clean energy penetration and otherwise. However, for a smooth transition to be recorded, reviews are needed due to availability, adequacy, stagnant growth as well as political reasons. A novel method to CCE should therefore take cognizance of various dimensions and complex nature owing to the stringent measure in eliminating localized ways of cooking. For the locals, this is already a way of life, a doctrine, a culture and a belief system.

Before this transformation, there is the need for moral requirement to properly educate and enlighten the indigenous people to ensure they are able to make informed consent and autonomous decision without any imposition, coercion, manipulation, or persuasion and the people's autonomy is respected (Faden and Beauchamp 1986; Beauchamp and Childress 1994). Besides, these technologies should be friendlier to the people and their natural environment; they should not make the environment hazardous and uncongenial to the people. They should conform to ethical duty (Desjardins 2006; Rachels 2007) and the utilitarian end (Rachels 2007) of the people and their environment, both at present and in the future. They should not be adopted on the sole aim of profit making and on the motive of instrumentalization of the people and their environment. Relying on the Divine Command Theory of Morality (DCTM), one is prompted to ask whether God would require, permit, or prohibit people being deceived, cajoled, or forced to jettison a way of life that they have been accustomed to and lived by or force them to accept a view and way of life that they may consider inimical to their well-being (Desjardins 2006). Unless these fears are allayed, there is no guarantee, for example, that when the Clean Cooking Stove (CCS) and other new technologies are provided to the locals during the AET period, they would not be stacked. Depending on the temperament of the people, there is the tendency to reject or put up resistance when



new ideas and ways of life are introduced to people who already feel secured in their comfort zones, unless adequate care is taken. There is the tendency on trade-cultural ground on the part of traditional rulers or chiefs and traditional doctors to have their meals cooked in special dishes and specified manners or methods and styles, if they are to retain their authorities, powers, efficacies, and sanctities, which may not be amenable to newly introduced alternative technologies. There may also be difficulty of embracing and adapting to new ways of life. Adjustments may cause lots of inconveniences and discomfort to the extent that the people may want to revert to their accustomed and secured styles of living. These may cause some friction in accepting newly introduced technologies.

Another issue of concern is that it pleases the locals to walk some kilometers to gather firewood at no cost rather than trekking some meters to expend their money in buying energy at a high price. Infact, some may not have money to expend in purchasing alternative energy due to their degree of poverty. It would be morally wrong to sway people away and “coerce” them into accepting a way of living they are unaccustomed to without adequate enlightenment programme and also without providing them with an affordable, safe, and simple alternative especially, if their previous methods and modes of living are innocuous, that is, it constitutes no harm or danger. In this way, the enforcing government, agency, or any other body fails in their moral duty.

For instance, in Nigeria, cooking in urban and rural areas is actualized by 50% and 99.8% of nonbiodegradable fuels, respectively. The high margin recorded in the rural areas is because they are unable to pay for a neater and cleaner substitute, lack awareness, and lack value systems in addition to the lack of accessibility to such fuels. Another challenge faced by the rural areas is stacking of any technology on the ground that they are scared of operating any electrical gadgets. Although their present technology might look cheap in the interim, other cooking options would be cheaper in the long run (National Energy Policy 2013). If remedial actions are not taken effectively, then the nation’s 15 million hectares of forest according to National Energy Policy (2015) could be depleted within the next 50 years, and the goal of AETP might not be met from the Nigerian perspective.

Also, the nonbiodegradable fuel source in Nigeria contributes about 37% of the total energy demand at a consumption rate of  $43.4 \times 10^9$  kg of fuelwood annually, making an average of 0.5–1 kg of fuelwood per person on a daily basis. This practice, has therefore encouraged the cutting down of trees, thereby making it a lucrative business owing to the huge and increasing demand of fuelwood, thus making Nigeria one of the largest fuelwood markets in the world (EIA 2014).

The cooking energy demand can therefore be represented mathematically in (1) as presented in NECAL (2015):

$$CED = \frac{CD}{H_H} \times \sum_{i=1}^n H_{H_i} \quad (1)$$

$CED$  = cooking energy demand,  $CD$  = cooking demand,  $H_H$  = household.

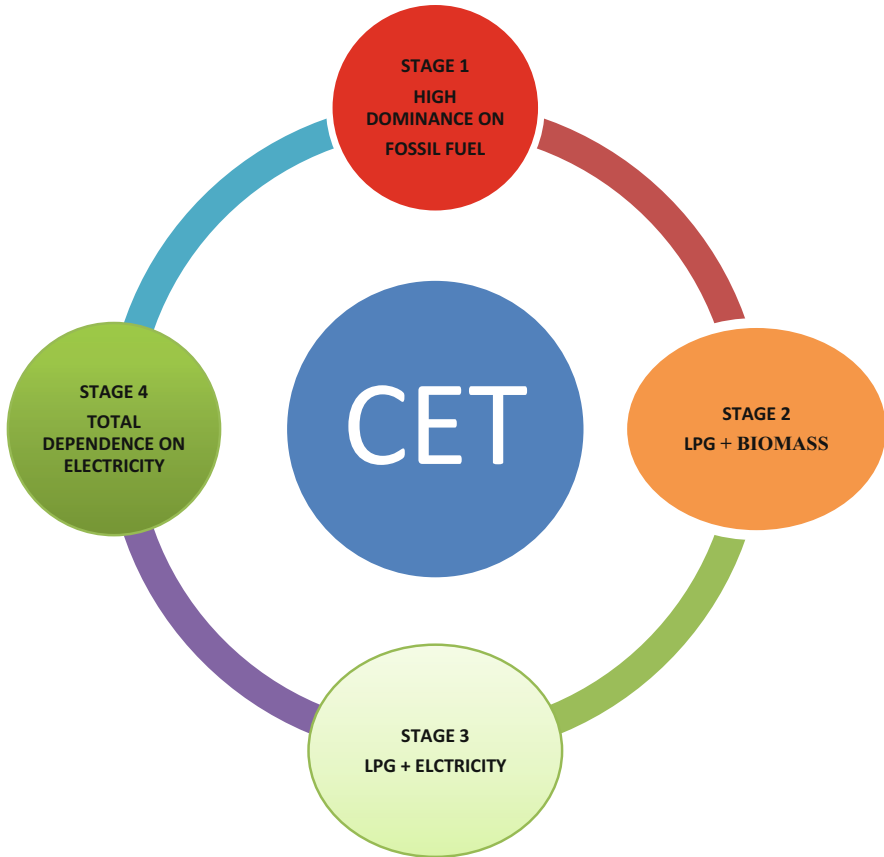
According to (ECN 2015), 71.9 million hectares of land in Nigeria is fertile, therefore making it a good potential for biofuel production other than fossil fuel. However, with the level of hunger and poverty, low gross domestic product (GDP), etc., it might be difficult to sacrifice the primary sources of biofuels which are actually foodstuff like cassava, sugarcane, soya bean, oil palm, etc. for the purpose of generating clean energy for domestic purposes. Although (Kela et al. 2015) have shown the introduction of CCS which includes clay-based improved stove, energy-saving stove, various solar cookers, double-pot improved stove, etc., their use is still at the experimental stage and therefore requires financial support to increase the level of awareness as well as mass production.

As a way forward, Olaniyan et al. (2018) proposed the use of nonfood crops for the production of bioenergy in some West African countries. However, based on the arable hectares of land in Nigeria and other African countries, another way forward is the genetic modification of certain biofuel plants for the purpose of producing fuel directly for domestic use and for the purpose of cooking. Plants with high calories can also be modified to produce more sugar than expected which can be used for fuel production. From these, excess sugar can actually be picked from the plant for the purpose of fuel production, and domestic use while the other part of the plants continues to remain edible for consumption thereby guaranteeing food security. Other than this, with respect to the AET, the full dependence on electricity for domestic use is also anticipated. In Fig. 1, the stages of AET and CET period are described. In Figs. 2 and 3, the level of merchandising of fuelwood and the use of solid biomass in cooking at restaurants in urban area are presented. From Fig. 3, it is shown that any deviation from this mode of cooking implies that the traditional smoky flavor is absent, hence reducing customers' patronage in the restaurant.

---

## Role of Government During the AET Period

There is a call across the globe for nations to move from "oil-driven economy" to "clean energy economy." Various changes are expected to be noticeable worldwide during this period with respect to regulations, policies, financing, consumption pattern, and so on. Now, what will be the fate of the individual citizens of those countries whose economy is strongly dependent on oil if the issues that directly affect them, and if what their daily living depend upon, are left at the hands of their decision-makers and the international community? Hence moral rectitude is required in convincing indigenous people. Again, given the abundant resources in their country, would they also transition during the AET period? If yes, at what pace? If no, why? The world is fully aware of the abundant primary sources of energy in Africa which are yet to be harnessed, and there is a call for a carbon-free environment in the nearest future, yet Africa continues to be the largest market for generator dealers across the world due to the high level of unreliability in the electric power sector. Part of the effects of generator use is that it constitutes health hazards to humans and the natural environment. It contributes to acid precipitation, depletion of ozone layers, carbon poisoning, and so on (Airoboman and Tyo 2018).



**Fig. 1** Anticipated CCS stages



**Fig. 2** Merchandising on fossil fuel in North-West Nigeria



**Fig. 3** Commercial cooking with solid biomass

There is therefore the need for stakeholders across the globe to deliberate on this issue to see how this energy can be managed in the most efficient way so that it can continue to be a means of wealth creation for the nations involved rather than asking or “forcing” them to give up their natural resources and go green. Also, if sustainability is to be recorded, then the number of portable generator sets penetrating the African market must be reduced and replaced with a more eco-friendly one. The role of each respective authority during the period would encompass awareness programs through the use of various advertisements, signs, agencies, and jingles, among others, to inform their citizens on the need to transiting from the use of solid biomass fuels to CET. The appropriate authority is also expected to enlighten its citizens on the cancerous effects that these fuels would cause in the long run and would continue to cause if their use is not abolished or optimized. The distance traveled by women and children to gather firewood contributes to the impairment of human development. Besides, the time wasted in all these processes which could have been valuably geared toward other meaningful engagements is also a call for the appropriate authority to answer. Climate change and depletion of the ozone layer is another strong point that the government is expected to use in convincing its citizens. How well this will sink into the hearts of the people is another cause of worry for the government. Therefore, integration of stakeholders and nongovernmental organizations (NGOs) whose job would be to interact and connect with the people one on one; study their beliefs, cultures, and ways of life; and then finally come out with the best and sustainable CET for a given community. It is also expected that electricity tariff should be made very simple and affordable. There should be guarantee by the concerned authority to its citizens that electricity, which is now their first choice of energy, will always be reliable and available when needed. Furthermore, the prices of the CCS should be subsidized and made at various sizes so that even the poorest person in a rural, peri-urban, and urban area can afford them.

## The Psychological Myth of Locals

Universal access to energy especially in the local community continues to be a worldwide priority by the year 2030, there is a need to look at how the lack of access to energy has contributed to development impairment and most especially how the CET would be appreciated by locals and the entire citizens of a given country especially in Africa. A key factor to be considered here is that the traditional fire does not only serve as a cooking stove, but it also plays other significant roles such as providing warmth during cold, drying of clay object, preservation of some agricultural product till the next planting season, prevention of weevils from some harvested crops, chasing out of wild animals from a vicinity, heating of the environment during a particular time of the year, a source of light during moonlight stories, waste disposal, drying of clothes, security purposes, and a sign of faith as practiced by some orthodox churches during a certain time of the year. If CET could penetrate the African continent, then it is expected that it should be able to address all these “ways of life” in the simplest manner and with simple technology. Besides, the CET should be cost-effective. The idea behind the use of CCS is simplicity in size and cost. If this is not achieved, various options to fuel available could make the CET objective a herculean task. Furthermore, there are some unique cultural preferences that might be difficult for locals to give up, and one of such examples is the traditional smoky flavor on meals prepared. The locals believed strongly that such flavors and taste could only be gotten through the use of fuelwoods and coal, and as such, the use of CCS could change the taste of their food. Even the rich often times visits small canteens where the source of energy used is firewood in order to get that traditional smoky flavor which makes their food sweet rather than visiting big restaurants whose source of energy is mostly microwaves because of the fear of radiation that causes cancer. The irony that the locals prefer to prepare their food using the traditional firewood because of its “simplicity” rather than using any other sources such as modern energy stoves because of their “complex nature” is also a call for concern and worry.

Simplicity for them is a priority and it comes before availability. Another issue of concern is that it pleases the locals to walk some kilometers to gather firewood free of charge rather than trekking some meters to expend their money in buying energy at a high price. In addition, some may not have this money to expend at all to purchase alternative energy due to their degree of poverty. Despite this “way of life” (which we may call archaic and uncivilized in the modern times), it is on record that people in villages live longer than people in the city. Hence, selling a technology from the city to the villages requires stringent measures. It would be immoral to impose, coerce, or deceive the locals to accept a method or an alternative way of life without informed consent, free choice, or adequate enlightenment, including relevant and adequate knowledge about the benefits and harms of the technology to be introduced. Concerning what makes an issue moral, Barcalow (1994) argued among others that the choices people make about such issues affect their well-being and the well-being of others; and such well-being may be physical or psychological. Such actions should also be capable of causing benefit or harm. It would also be a moral

dilemma for those knowledgeable or well informed about the actual and potential hazards of the habits and practices of a people to allow them to continue in those habits whether or not it directly affects them, when they are unwilling to change.

---

## A Look at Environmental Ethics

The heavy burden imposed on nature in recent times because of various activities by humans, it is now impossible for nature to regenerate itself the way it used to. Environmental ethics could therefore be put forward as one of the ways of tackling environmental issues and simultaneously meeting human needs. According to Omonzejele et al. (2017), every culture possesses certain notion of what is good and bad and what “ought” and “ought not” to be done. Therefore, the bad aspects of using fossil fuel plants for the purpose of heating, cooking, drying, security, etc. by rural areas may be left hanging as it is already a value system and a way of life; hence, all they see is the “good” aspect of using fossil fuel as the word “bad” may sound offensive because of what it projects and represents. The rural dwellers are of the opinion that the human life has value. Then, if prevented to sufficiently interact with its environment, it may be tantamount to saying the value of the non-human life is superior to the human life, and this could negate their traditional and cultural doctrines of Anthropocentrism. Therefore, a point of alignment between the non-human life and the human life needs to be defined to address these stringent issues with respect to educating the rural dwellers especially on the doctrine of Sentientism which opined that an element of consideration should be afforded to the non-human life. Also, the doctrine of Biocentrism strongly stated that all life is sacred! In this sense, the human life must refrain from cutting branches from trees for any purpose. The doctrine of Ecocentrism also asserts that nature is the center for the existence of human life upon which this life is parasitic. In Airopoman (2017), one of the reasons for environmental concern is to curb issues and proffer solutions on issues relating to climate change. The author stressed that development is a function of the level of interaction with the environment. However, with the present climate change challenges, one may ask if the gain as a result of development is worth the trouble posed by the climate? If yes, should the underdeveloped nation aspire to develop or remain static developmentally because of possible fear of climate-related issues? These questions are begging for answers. Therefore, environmental ethics should be included in high school and colleges curricula in order for all parties involved to be guided accordingly.

In Fig. 4, the occupant of the apartment uses LPG for cooking. However, the color of the ceiling shows otherwise, and this may be a result of the inefficient way the LPG was used, thereby constituting environmental challenges as well health challenges especially to the occupant of the apartment. CET should not just be about the use of clean energy but also of the way(s) it is used with respect to each environment. As a means of addressing the myth behind cooking using the CET, the authority concerned would have to convince the masses that:

**Fig. 4** A polluted kitchen



1. The technology behind CCS would be very simple such that it would be easy to operate.
2. It is not time consuming because the energy required would always be available rather than traveling longer distances to fetch firewood.
3. Maintenance of the CCS would also be made very simple and available.
4. The locals would be involved directly in the maintenance, thereby creating jobs for them.
5. It is the presence of carbon black that affects visibility. Hence, there should be a paradigm shift.
6. There are negative impacts on the method they have been accustomed to have on the natural environment.
7. There are actual and potential hazards, which impact the human beings, future generations, and general ecosystem.

In addition to the above, there is also a need by the authority concerned to introduce CCS designed to give that traditional smoky flavor in food, as well as addressing the fear in operating CCS because of its “complexity” and fire hazards.

---

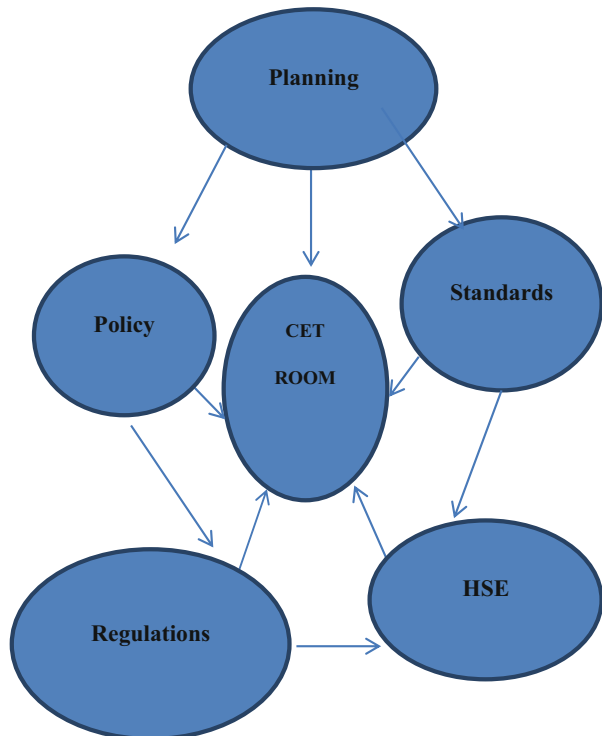
## **The Way Forward**

As the world continues to strive in meeting its objectives regarding universal access to energy and CET, there is a need to deplore methods to be followed in order for these objectives to be met. In Fig. 5, a model which incorporates planning, policy

making, regulations, health, and safety and standards is proposed. In this scenario, analysis is done at various levels to get a master plan for CET in the near future.

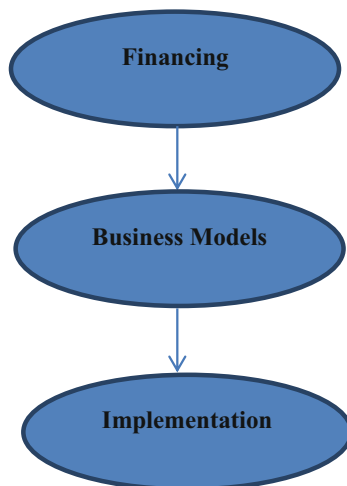
1. The planning level involves various coordinated policies and strategies to be adopted for a smooth AET.
2. The policy level should incorporate the drafting and implementations of policies.
3. At the regulation phase, it is expected that suitable regulation standards both technical and economical are taken into cognizance. The direct involvement of government is expected here because it has to protect the consumers' right and ensure that any tariff adopted must be simple and cost-effective.
4. Health and environment protection agency regulates the impact of the technology on the health and safety of the environment as well as the personnel.
5. At the standard phase, regulations such as conformity to WHO standards should be enforced. It should be noted that it is not only laboratory test that is required here; other regulations that will ensure sustainability through availability of spare parts and maintenance must be taken into cognizance.
6. The CET room investigates the report from various agencies, regulators, and policy makers to see the potentiality of the CET penetration in a given area, and when satisfied, they move to the next phase as shown in Fig. 6.

**Fig. 5** CET policies and regulatory phase





**Fig. 6** CET implementation stage



The second stage of the model comprises the financing, the business models to be adopted and finally the implementation.

1. At the financing phase, it is expected that there is enough fund to support investors, willing to go into the CET business. There should also be a body under the CET that manages and gives out funds to potential investors. There could also be a Public Private Partnership that allows these investors to build, operate and transfer the technology at the required time.
2. Furthermore, it is expected that stakeholders in the sector will have to meet and develop business models that favor a given region with respect to the natural resources available in that region.
3. Since the goal of every business is to get return on investment, it is expected that this phase should be time consuming owing to various scenarios analysis and feasibility study needed to ensure a very simple but affordable tariff expected by potentials customers. When all this is put in place, the implementation stage comes to fore. This involves the coordination and supervisory roles needed during installation of CET within a given area. Such supervisory role should be handled by an expert in the field who will ensure that all equipment deploy to the field conform to appropriate standard, pass the LAB tests and also meets the WHO requirements.

---

## Conclusion

In this chapter the injustices that lack of energy access has caused globally and especially in sub-Saharan Africa is highlighted. Energy poverty has slowed down technological infrastructure and has led to a slow economic growth rate. As the

world is expected to transition to renewables and CET in the nearest future, it is expected that there would be a swift shift from the use of solid biomass fuel to electricity. Therefore, there is a need for Africans and especially sub-Saharan African to start preparation for the AET in earnest in order not to be caught in the web of uncertainty. With proper preparation, good policies, regulations, proper planning, nice business models can be put in place in the African continent because Africa has been designed to rule the world in the nearest future. Hence we must get our technology right; and in doing this, there must be a universal access to energy especially to women and children. The study also concurrently looks at some socio-cultural and economic impediments that may have impeded this goal, as well as some moral issues involved and attempt to address them.

---

## References

- Aboua CA, Toure YFE (2018) Efficiency in West Africa economies: implication for sustainable energy. *Ecovas Sustain Energy J* 1:65–91
- Airoboman F (2017) A survey of environmental ethics: “the substance of ethics and morality” Published by The Department of Philosophy, Faculty of Arts University of Benin, Nigeria, pp 149–169
- Airoboman AE, Tyo TM (2018) Operation save energy: the grid defence mechanism in sub-Saharan Africa. *Am J Eng Res* 7(5):130–135
- Barcalow E (1994) *Moral philosophy: theory and issues*. Wadsworth Publishing Company, Belmont
- Beauchamp TL, Childress JF (1994) *Principles of biomedical ethics*, 4th edn. Oxford University Press, Oxford
- Desjardins JR (2006) *Environmental ethics: an introduction to environmental philosophy*, 4th edn. Thomson Wadsworth, Belmont
- ECN (2015) *Biofuels Training Manual*, Federal Ministry of Energy, Nigeria
- Energy Information Administration (EIA) (2014) United States of America. <https://www.eia.gov/countries/country-data.cfm>
- Faden RR, Beauchamp TL (1986) *A history and theory of informed consent*. Oxford University Press, Oxford
- IEA (2014) *Africa Energy Outlook: A Focus on Energy Prospects in Sub-Saharan Africa* (World Energy Outlook Special Report), pp 1–242
- IRENA (2019) *Future of solar photovoltaic: development, investment, technology, grid integration and socio-economic aspects*, pp 1–73
- Kela R, Tijjani A, Usman K (2015) Current status of research and development activities on efficient cookstoves in Nigeria. *J Energy Policy Res Dev* 1(2):50–62
- National Energy Policy (2013) Energy Commission of Nigeria, Draft Revised Edition
- National Energy Policy (2015) Energy Commission of Nigeria, Draft Revised Edition
- Nigeria Energy Calculator (2015) Energy Commission of Nigeria. Department of Energy & Climate Change (Federal Ministry of Science & Technology). <https://www.nigeria-energy-calculator.org>
- Olaniyan OF, Taal P, Kara AA, Adewale A, Ceesay K (2018) Factors influencing the use of non-food agricultural biomass for renewable energy generation: a stakeholders’ analysis in the Gambia, West Africa. *Ecovas Sustain Energy J* 1:93–104
- Omonzejele PF, Ukagba GU, Asekhaumo AA (2017) African traditional ethics: the substance of ethics and morality” Published by The Department of Philosophy, Faculty of Arts University of Benin, Nigeria, pp 113–124

- Rachels J (2007) A short introduction to moral philosophy. In: Rachels J, Rachels S (eds) *The right thing to do: basic readings in moral philosophy*, 4th edn. The McGraw-Hill Companies, Inc., Boston, pp 1–19
- WEO, 2017. Special Report: Energy Access Outlook – Analysis. <https://www.iea.org>. Access 14 Mar 2020 15:15hrs

**Open Access** This chapter is licensed under the terms of the Creative Commons Attribution 4.0 International License (<http://creativecommons.org/licenses/by/4.0/>), which permits use, sharing, adaptation, distribution and reproduction in any medium or format, as long as you give appropriate credit to the original author(s) and the source, provide a link to the Creative Commons license and indicate if changes were made.

The images or other third party material in this chapter are included in the chapter's Creative Commons license, unless indicated otherwise in a credit line to the material. If material is not included in the chapter's Creative Commons license and your intended use is not permitted by statutory regulation or exceeds the permitted use, you will need to obtain permission directly from the copyright holder.





# Green Technology Approaches to Solid Waste Management in the Developing Economies

# 63

T. B. Hammed and M. K. C. Sridhar

## Contents

Introduction .....	1294
Green Technology Approach to Waste Management and Climate Change Mitigation and Resilience in the Developing Economies .....	1295
Field-Oriented Activities at Renewable Resource Centre, University of Ibadan .....	1297
Activities and Climate Change Adaptive Technologies at Various Sections of the Center .....	1299
From Climate Change to Community Change: Lesson from Kube-Atenda, Nigeria .....	1304
Integrating Waste Picking at Dumpsites into a Value-Added Chain in Nigeria .....	1305
Waste-Picking Activities at the Dumpsites: A Case Study of Ibadan, Nigeria .....	1306
Conclusion .....	1310
References .....	1310

## Abstract

The severity of extreme weather and climate change impacts around the world has been a public health concern in the last few decades. Apart from greenhouse gas generation, poor waste management exacerbates consequences of global warming such as flooding, lower crop yields, and the epidemic of diseases which can escalate into disastrous situations. The general public in developing economies sees wastes as valueless materials and disposes them through open burning, stream dumping, or as conveniently as possible. Also, the cutting of trees for firewood leads to deforestation and desertification that increase people’s vulnerability to climate change impact. Against this backdrop, there is a need for a paradigm shift toward developing indigenous technologies that convert solid waste to cheap and clean energy. Various innovations use the “green technology approach” in putting trash back into the value chain. Furthermore, the green technology approach has a great potential to enhance adaptation and resilience

T. B. Hammed (✉) · M. K. C. Sridhar  
Department of Environmental Health Sciences, Faculty of Public Health, College of Medicine,  
University of Ibadan, Ibadan, Nigeria

among climate change-displaced populations where they can set up microenterprise on useful end products. In this chapter, unique features of these technologies at the Renewable Resources Centre of the University of Ibadan, practice-oriented researches, and a case study at Kube-Atenda community Ibadan, Nigeria, are presented. This chapter is therefore set out to showcase examples of waste management initiatives and strategies that have been successfully implemented elsewhere by the authors. It also focuses on how some countries in the continent, with developing economies, may foster their resilience and their capacity to adapt to climate change.

---

**Keywords**

Climate change · Waste management · Greenhouse gas · Indigenous technologies · Gaseous emission · Value chain

---

**Introduction**

Africa continent is at the forefront of vulnerability to global climate change within the world. The overall public in this continent sees wastes as valueless materials and disposes them through open burning, stream dumping, or as conveniently as possible (Hammed et al. 2018). Healthcare wastes are burnt in low-temperature incinerators with gaseous emissions. Also, the cutting of trees for firewood ends up in deforestation and desertification that increase people's vulnerability to temperature change impact. As an example, many households in Nigeria (up to 70%), including households in rural areas (86%), and households in urban areas (42%), depend on solid fuel as their primary source of energy (Sridhar et al. 2016). The majority of the families that use solid fuel for cooking (94%) operate open fire or stoves that have no chimneys or hood (Gwatkin et al. 2000). Other than climate change, the utilization of firewood as fuel for cooking exposes people, and most children and women, to smoke which poses a health risk to them and might cause respiratory illnesses (Salvi and Barnes 2010; Oluwole et al. 2012). Consistent with some researchers (Smith et al. 2001; Dehoust et al. 2005), the waste management sector makes a relatively minor contribution to greenhouse gas (GHG) emissions at a global scale, estimated at approximately 3–5% of total anthropogenic emissions in 2005. Also, the average annual per capita waste generation in developing nations is estimated at 10–20% of that of developed countries, which is rising in response to economic growth. The waste sector is, however, in an exceedingly unique position to maneuver from being a secondary source of world emissions to becoming a major saver of emissions. It is on this premise that the Chief Director of the United Nations Environment Programme (UNEP) has been developing a technique for cobenefits of waste management within the context of global climate change. Integrated Solid Waste Management (ISWM) based on the 4Rs (reduce, recycle, reuse, and recovery) approach, with a special focus on sustainable consumption and production, E-waste management, conversion of agricultural biomass and waste plastics into

energy and material resources, and management of hazardous waste, is being considered by the UNEP (UNEP 2010).

A recent report by Oyelaran-Oyeyinka of the UN Human Settlements Programme (UN-Habitat) (The Guardian, 27 April 2015) indicated that “African cities are the engines of wealth creation and therefore the centers of manufacturing, production, and innovation.” This fact has not yet been justified and, as such, many cities have changed to slums that are characterized with incessant poverty, homelessness, the prevalence of preventable diseases, environmental pollution, maternal and child mortality, and other problems. These problems are further aggravated by social, economic, and environmental issues posed by climate change. There is, therefore, a need to strategize how African nations may foster their resilience and adaptation to the implication of climate change. Moreover, UNEP has identified two categories of solid waste management techniques that can reduce GHG emissions or contribute a net benefit to the development (UNEP 2010). The first set of technologies in view is technologically simple, locally available, and relatively cheap. The other set involves sophisticated, expensive technology and typically requires over 5 years to implement due to some factors, including financing, planning, and regulatory processes. The first process is seen to be very useful to strengthen resilience and adaptive capacities to counteract climate-related hazards within the developing economies. This chapter showcases samples of successful waste management initiatives and strategies that have been successfully implemented at the grassroots to build the capacity of the rural and urban dwellers, and foster their resilience to the menace of climate change.

---

## **Green Technology Approach to Waste Management and Climate Change Mitigation and Resilience in the Developing Economies**

The significant problems of solid waste management in low-economic settings include lack of interaction and collaboration between stakeholders (community members, researchers, industrialists, and policymakers) in the policies that deal with waste. Also, there is a lack of political will for a waste-recycling program, no provision for research funds, unavailability of sustainable technologies and over-dependence on imported technology, and lack of transparency and marketplace for recycled products. There is usually no sense of belonging in utilizing any project in which the end-users are not involved and motivated (McDonald and Ball 1998; Tucker et al. 1998; Paula and Elizabeth 2008; Fauzul and Viradin 2011; Hammed et al. 2012). Consequently, waste disposal systems do not conform to best practices, and in most cases, there is no sound or acceptable disposal method for solid waste in place. These wastes are usually heaped in piles within residential areas and often-times burnt once they overflow, or the stench from them becomes unbearable, creating air pollution-associated issues. The disposal and treatment of wastes lead to GHG emissions with severe global climate change impacts. Methane is the most significant GHG gas emanated from solid waste in the landfills, which is released during the breakdown of deposited organic matter (IPCC 2006).

The gross of socioeconomic, environmental, and health difficulties the climate change phenomenon brings to the human being is depletion of natural resources, atmospheric pollution, outbreaks of vector-borne diseases, and flooding as well as crop failures that lead to malnutrition. Ironically, these impacts are mostly strongly seen and felt in developing countries, whose contributions to GHG emissions are far lower than their counterparts in the industrialized world. The aforementioned has called for effective initiatives and strategies such as those that supply renewable power from waste, mitigate climate change, create job opportunities, and promote growth in Gross Domestic Product (GDP) through wealth generation mechanisms. Generally, the benefits of green technology approach in the form of 5Rs (reduce, reuse, recycle, recover, and repair) to waste management include:

- Conservation of natural resources
- Environmental sanitation and protection from soil erosion, gully problems, deforestation, and desertification as trees are not cut
- Prevention of biodiversity loss
- Reduction of demand for landfilling of wastes
- Job creation and poverty eradication in the state; create wealth among peasant farmers
- Food security in the country through organic fertilizer production
- Promotion of local technology for sustainable development
- Reduce the amount of CO<sub>2</sub> and methane gas being released into the atmosphere
- Saves foreign exchange for the nation

Considering the hierarchy of sustainable waste management, waste prevention is generally far better than any other waste management practice. That is, waste prevention eliminates greenhouse emissions and other environmental problems that are resulted from waste disposal and also ensures fewer resource extractions and manufacturing (the United States Environmental Protection Agency 2006). Following waste prevention, in terms of benefit, is waste recycling which may be a closed-loop or open-loop process. The open-loop recycling process occurs when recycled material is employed to form a completely new item. During this case, there is a loss of fabric quality which is brought up as “down-cycling.” Another strategy being employed in line with waste recycling is industrial symbiosis. Here, industries exchange useful by-products among themselves (Ashton et al. 2009). Sometimes, the industries involved in this arrangement may form “recycling clusters” to facilitate the sharing of resources (Chertow and Lombardi 2005; Harris 1999). A good example is the United Kingdom’s National Industrial Symbiosis Programme that has successfully saved more than five million metric tons of wastes that could have ended in landfills and eliminated more than five million metric tons of GHG emissions since 2005 (Chertow 2009). The above state of affairs illustrates the necessity for identification of processes, methods, and tools which may help African nations from international best practices. This approach calls for global thinking and local action.

## Field-Oriented Activities at Renewable Resource Centre, University of Ibadan

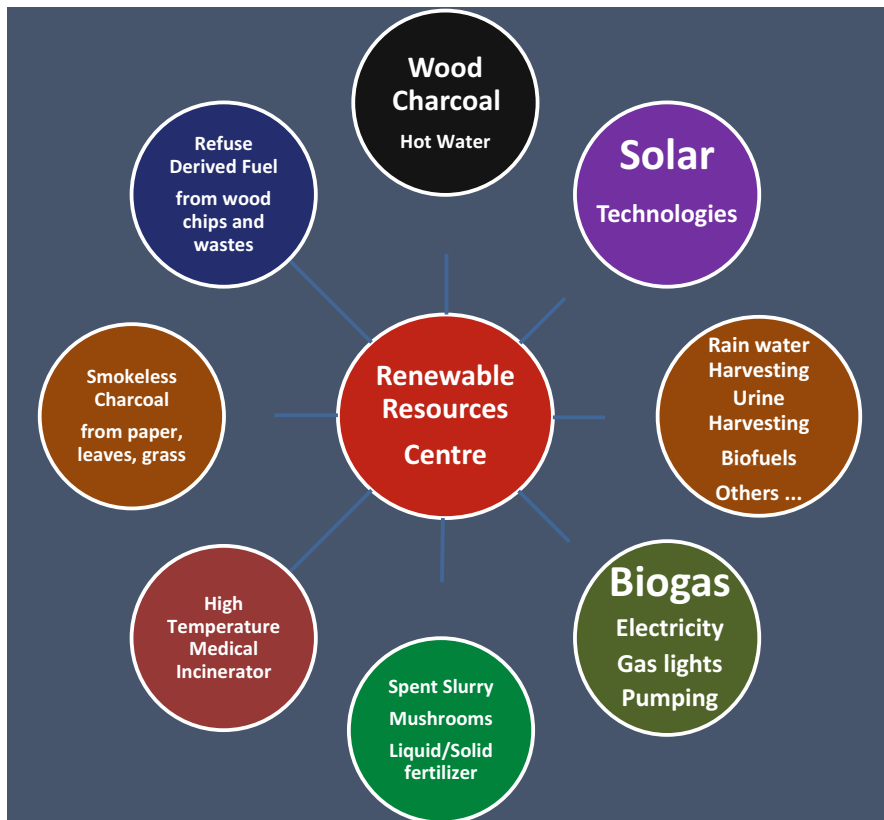
The Renewable Resource Centre (RRC), located in the poultry unit of the Teaching and Research Farm, University of Ibadan, Nigeria (Fig. 1), was established in the year 2013. The center started with a few viable technologies developed in the Department of Environmental Health Sciences of the University which were scaled up in the field at several locations nationwide. The techniques are now proven to be viable to exploit commercially. The RRC has several sections, which are shown in Fig. 2:

- (i) A building with training facilities to train up to 30 trainees, a storeroom, a research exhibition area (TECH park) to display environmental health research outputs, a caretaker's restroom, two toilets for visitors, a well-equipped mushroom spawn production area, and a small lounge where a visitor can sit and relax.
- (ii) Biogas digesters to generate biogas from poultry piggery and cattle wastes for lighting and compression into cylinders.
- (iii) A mushroom cultivation hut with thatched roof and bamboos, and accessories to produce on a large scale.



**Fig. 1** The RRC main building in the university





**Fig. 2** Various sections at Renewable Resources Centre

- (iv) Liquid fertilizer production from biogas-spent slurry.
- (v) Permanent kiln for smokeless charcoal/biochar production.
- (vi) Charcoal Kiln (a design adopted from Kenyan/Ethiopian technology) to produce charcoal within 24 h from fallen and cut trees.
- (vii) Home composter for low-scale production of compost at house and farm unit.
- (viii) Portable refuse-derived fuel unit.
- (ix) A demonstration plot land set aside opposite the biogas section for demonstrating some of the products for agricultural production. Here, various field-based experiments are carried out.
- (x) Rainwater harvesting for ensuring the availability of water all year round with elementary and useful technology.

It is expected that the RRC will become a center of attraction for people to get trained on “Waste to Wealth” and “Waste to Energy” technologies. The center will benefit Nigerian communities as well as other developing economies through “Town and Gown” meet.

## Activities and Climate Change Adaptive Technologies at Various Sections of the Center

**Training Hall:** About 30 people can comfortably sit and receive training. The room is equipped with two air conditioners, a PowerPoint projection, and a cupboard to display some standard books for the trainees to use. The target training participants include interested individuals, small and big scale farmers, members of cooperative society, students, and retirees (Fig. 3a).

### Biogas Generation and Compression

There are two types of biogas digesters: One is 8 m<sup>3</sup> capacity, flexible, and a product of PVC which can expand as the gas is generated (Fig. 4a). This kind of digester is suitable for larger families or establishments that need more gas for consumption. The other is a unique floating dome variety; the capacity can vary from 1 to 10 m<sup>3</sup> or more, built from readily available water storage tanks from the local markets. They are affordable for households and have the potential for promotion at community levels to individual families. The biogas plants are designed to use dairy waste, poultry waste, piggery waste, or food waste from



**Fig. 3** Training activities at the center (a, b, c, d)



**Fig. 4** Various components at RRC: (a) biogas compression unit; (b) effluent treatment filtration tank; (c) mushroom spawn production room and (d) con-planted on treated effluent with many fruits on a stem

kitchens. Available end products from this section are biogas lamp, biogas compressor, biogas- multipurpose electricity generator, space heater, cooking stoves, and liquid and solid fertilizers produced from an effluent treatment filtration tank (Fig. 4b). The lamp is suitable for lighting an area without greenhouse gas emissions while the biogas cleaning unit is used to increase the percentage of methane. There is a kit that can be fixed to a household petrol-driven generator so that it can be adjusted to use petrol, natural gas, or biogas. The biosolids obtained after proper filtration are made into a very rich organic fertilizer that is used for mushroom cultivation (Fig. 4c) and raising crops at the demonstration plot (Fig. 4d). Besides, the space heater is used for warming young chickens in the poultry pens. At the same time, biogas fuel conversion kits and the portable cylinder are being tested to run vehicles, including cars, motorcycles, and tricycle, on biogas production from organic waste.

### **Mushroom Cultivation**

A mushroom hut was built using materials ideal to maintain the required low temperature and humidity. In this hut, mushrooms will be grown from waste materials such as spent slurry, sawdust, etc. Also, bottles of spawn (mushroom seedlings) of various tasty varieties are produced for household cultivation.

**Wood Charcoal Kiln**

A lot of trees fall due to heavy breeze and storms, and they are moved out by needy people for cooking purposes in an environmentally unfriendly manner that exacerbates climate change effects. A modern kiln available at the center can convert wood and cutoff trees to quality charcoal good commercial value (Fig. 5f). The furnace



**Fig. 5** Other climate change adaptive technologies at RRC: (a) RDF plant; (b) smoke-free incinerator; (c) household composter; (d) smokeless charcoal kiln; (e) smokeless charcoal pellets; (f) wood charcoal

eliminates the traditional rural practice of digging holes all around and burning the wood openly, thus releasing greenhouse gases. In a 48-h cycle, 15–25 bags of charcoal are produced. Apart from a brick-made kiln for wood charcoal, there is another metal type (Fig. 5d) that converts light putrescible wastes to smokeless charcoal that is very popular in most of the western countries. By definition, when the charcoal is burned, no smoke is generated in the kitchen. This technology converts agroforestry residues: grass clippings, fallen leaves, maize stalks, lawn mowing, paper, sawdust, and other wastes from farms to biochar useful for farm input, wastewater treatment domestic cooking (Chang et al. 2011), warming house during cold weather, septic tank treatment, and others. The end product is in the form of charcoal powder (biochar) which is pelletized using a hand-operated extruder after some binder is added. Rejects and dust in the wood charcoal kiln are charged with treated effluent from the biogas digesters to produce nutrient-rich biochar that is sold to farmers as cheap fertilizer. The center also provides biocide-embedded smokeless charcoal for malarial control and energy for domestic cooking, at the same time (Fig. 5e). In the charcoal production process, a lot of heat is lost to the environment. The technology incorporated piped water into the furnace, whereby the temperature can be used to produce hot water. The poultry on the farm uses a lot of hot water, and it is a benefit.

According to Ana et al. (2013), global warming and its consequences on climate are among the problems posed by overdependence on fossil oil reserves. These drawbacks require exploring alternative energy sources such as biofuels that are environmentally friendly and renewable. Meanwhile, Bouros and Samiou (2001), Da Costa et al. (2004), and (Karve 2006) have earlier linked gaseous emissions from wood charcoal fires especially in an indoor environment to the incidence of many respiratory illnesses. The use of smokeless charcoal can reduce indoor air pollution, diseases, and gross environmental problems, arising from solid waste mismanagement while creating access to business opportunities for women and disadvantaged groups.

### **High-Temperature Incinerator**

For managing healthcare wastes, a recommended method is incineration operated at 1200 °C (Fig. 5b). However, none of the incinerators utilized in developing countries meets that requirement as they generally produce temperatures below 600 °C. World Bank tried to promote an incubator designed in the UK (De Montfort). Even this model is not able to maintain such an extreme temperature. Through locally developed and improved technology, the center designed an incinerator that uses heat generated from syngas. The heat is injected back into the incineration chamber to increase its temperature to around 800–1000 °C. The unit can also be used to handle pyrolysis of scrap tires and some types of e-waste which is an emerging global environmental health importance, as these wastes have become one of the fastest-growing waste types in the world (Sharma et al. 2012). The available end products in this section are carbon black and black oil that are generated from the smoke that might contribute to global warming as well as metal scrap salvaged from scrap tires. The distinctiveness of the plant is that: the unit is entirely covered to reduce the

emission of GHGs, heat produced during the operation, in form of syngas, is used to replenish the furnace temperature, and the smoke generated is converted to diesel after some treatment. The unit can be operated safely at any convenient place since there is no pollution of the environment. Additionally, materials used in constructing the unit are locally available while the unit powers itself to treat hazardous wastes, hospital waste, and agricultural wastes.

### **Refuse Derived Fuel (RDF) Plant**

This compartment uses small wood chips (paper or any dry waste) and charcoal which on heating produce a black oil and, on further heating, produce a gas (syngas). This gas can be stored in a bag or cylinder and may be used to run a household generator to produce electricity, similar to biogas. The gas can also be used directly such as biogas for cooking at the household or institutional level. In this section, the end products are syngas and charcoal that emit very little smoke. This new innovative technology (Fig. 5a) has been developed to generate syngas from all types of combustible solid wastes and use the gas to run generators for electricity. In addition to health safety and environmental protection, this technology will be of great benefit to the rural and peri-urban populations who may want to develop small or medium scale entrepreneurship with low investment and very little skills. It does not need electricity or any sophisticated mechanical devices.

Gasification- and pyrolysis-related processes are usually confused with one another. Zhou et al. (2008) identified the major difference between the two methods as the gasification occurs in the presence of oxygen. On the other hand, pyrolysis does not require oxygen or air during its process. However, gases and liquids produced in the pyrolysis and gasification processes have high contents of carbon monoxide (CO) and hydrogen gas (H<sub>2</sub>) that can be a good source of syngas. The syngas is used for the production of methanol and ethanol or H<sub>2</sub> used in fuel cells (Baumlin et al. 2006). For example, gases with the main benefit of pyrolysis is that it offers clean heat, which is needed to develop cooking technology with lower indoor pollution by smoke than is typically generated during the burning of biomass (Bailis et al. 2005). Also, the by-product is smokeless briquette charcoal, because, during carbonization, its smoke disappears.

### **Home Composter**

This unit was designed for low-scale production of compost at houses and farm units (Fig. 5c).

The RRC is intended to be operated on a sustainable basis through various sources of revenue generation, including the following:

- (a) Consultancies and turnkey projects for public and government bodies on the technologies developed at the center (fertilizer, biogas, charcoal, smokeless charcoal, etc.)
- (b) Sale of products such as charcoal, biogas kits, mushrooms, maggots, liquid and solid organic fertilizers, black oil, carbon black, and organically grown produce from the demonstration plot

- (c) “Science Tourism” and education visits of schools, and the public
- (d) Assisting researchers through the use of locally fabricated equipment
- (e) Training programs (short-term) and hands-on training
- (f) Donors and philanthropists
- (g) University support for innovative researches and grants
- (h) Hospital waste management services
- (i) Compression of gas into cylinders for domestic uses

---

### **From Climate Change to Community Change: Lesson from Kube-Atenda, Nigeria**

This scheme is community-led waste management for reducing greenhouse gas emission and mitigating climate change effects at Kube Atenda, Ibadan, Nigeria. The project was carried out under the Climate Impacts Research Capacity and Leadership Enhancement in Sub-Saharan Africa (CIRCLE) program and executed by the UK’s Department for International Development (DFID), in collaboration with the Association of Commonwealth (ACU) and African Academy of Sciences (AAS). Transformative adaptation and sustainable responses to climate change (Fig. 6a–d) that were adopted included: a large scale stakeholders’ workshop that comprised community people (the users), local council representatives, private practitioners, and selected people from the general public; creation of a sorting center/recycling kiosks for recyclable buyback arrangement and entrepreneurship opportunities; Waste-to-Electricity through a newly invented pyrolytic chamber for converting accumulated waste to energy and useful by-products; developing market links for recyclables between the community’s buyback center and resource recovery centers; developing effective communication among all the stakeholders and decision-makers; and instituting monitoring and evaluation for progress control through the involvement of Department of Community Development Inspectorate (CDI) at Ibadan Northeast LGA (local council). Specifically, this project focused on behavioral change of the community member toward solid waste management practices that will ensure wealth creation and development, using the 4R concept (Reduce, reuse, recycle, and recover).

Before this uptake activity, the community had been faced with a big challenge of solid waste management. There were heaps of waste around the community while people were disposing of their garbage on illegal dumps, in open spaces, and in water bodies, or burning them openly in an environmentally friendly manner. The training component of the research led to building people’s capacity in waste to wealth as the community members were taught on how to sort their solid waste into paper, glass, plastics, and other recyclables for recycling, reuse, and sale at the community buyback center. They were also taught a way to produce organic fertilizer from organic waste and biochar (smokeless charcoal) from agroforestry residues to generate an inexpensive and clean source of energy for domestic cooking. There was a rise within the level of awareness of the consequences of poor solid waste



**Fig. 6** Climate change mitigation and adaptation initiatives at Kube-Atenda: (a) recycling kiosks for recyclable buyback arrangement, (b) field demonstration on charcoal production, (c) pyrolytic chamber, and (d) phone-charging center

management, such as health hazards, esthetic damage, and other environmental problems in the community.

Moreover, the pyrolytic chamber generates gas that powers a generator for electricity supply and produces black oil from which diesel and kerosene can be distilled. The electricity supplied is used to power a phone-charging center (Fig. 6d) that financially empowers the youths who are managing the center.

The center is now a study area for young- and midcareer researchers and postgraduate students in universities across the country. This project is meeting the people's needs, including economic development, safe environment, poverty reduction, and healthful living. Also, policymakers in the state and across the country will find the uptake and research evidence very useful in their planning and activities.

## **Integrating Waste Picking at Dumpsites into a Value-Added Chain in Nigeria**

Old dumpsites contain a high proportion of recyclables, including minerals and metallic components including e-waste, ferrous scrap, aluminum, and copper cable that could be salvaged and reprocessed. Also, the highly calorific waste components



(wood, plastics or paper, textiles, and paper) could be used to generate energy (Bachmann and Cordes 2007). Recycling of these wastes has the potential to create jobs for waste pickers, by promoting entrepreneurs to establish waste recovery facilities at dumpsites. Adding waste into the value-added chain formally will reduce the quantity of wastes disposed to landfill sites and improve the practices that endanger the health and safety of waste pickers, at landfills/dumpsites.

In many developed countries such as those within the European Union, policies of reduction, reuse, and diversion of wastes from dumpsites/landfill are strongly promoted (European Environment Agency 2003). The situation is quite different in Nigeria as the main fractions of wastes generated are recyclables including organic materials, plastics/rubbers, cardboard, metals, and glass bottles (Ojolo 2004). These wastes are stored and transported directly to some designated dumpsites where they are burnt eventually. This practice has potential impacts on the health and hygiene of people in the neighborhood and the esthetic nature of the environment.

Zerbock (2003) noted that waste dumping is the well-liked method of putting off solid waste rather than sending wastes to landfills in most African countries. Wastes are solely dumped in low-lying areas without engineered measures to prevent environmental pollution. In open dumps, there is no consideration for leachate and gas management. Also, operational standards, such as registration of users, control of the number of tipping fronts, or compaction of waste, are few, if not absent. This method is neither hygienic nor safe as waste is tipped haphazardly. However, African countries have a minimal choice because of their low financial capacity and lopsided institutional arrangements. The responsibility of waste disposal is vested in local governments which are weak and cannot usually raise money to construct sanitary landfills. Some countries use semicontrolled landfills whereby wastes are dumped uncontrollably at designated dumpsites without covering with topsoil to prevent odor and rodent nuisance. In this kind of landfill, various wastes such as municipal, industrial, or clinical/hospital wastes are dumped, not following internationally approved best practices.

### **Waste-Picking Activities at the Dumpsites: A Case Study of Ibadan, Nigeria**

Through Focus Group Discussion (FGD) sessions and observation checklist, the authors assess the dynamic of waste picking at the four designated dumpsites in Ibadan, Nigeria. The dumpsites included in the survey were: Ajaganka, Awotan, Lapite, and Afonfura. For the FGD, questions were structured to cover the following major activities: population and category of workers, business activities, method of business apprentice, factors that affect the operation, including technical, environmental, social, and economic factors, and perception of scavengers on business optimization and improvement.

### **Category of Workers and Prices of Items**

When asked about the number of scavengers at each dumpsite, the following responses were gathered: Ajaganka – 20 (17 males and 3 females); Awotan – 20 (15 males and 5 females); Lapite – 5 (4 males and 1 female); and Afonfura – 28 (18 females and 10 males). There were more males than females except at Afonfura where 18 females were found as against 10 males. As per the year of experience, the age ranged between 3 and 20 years. According to the discussants, there was a competitive demand for recyclables. They sold the recyclables to the manufacturers who came to buy them directly from the sites. Each recyclable had a fixed price and the unit of measurement was either in kg, ton, or dozen, depending on the types of recyclables. The prices of the recyclables were given thus: tin (including milk can) – 20/kg; pet bottles – 30/kg; glass bottles – 20/dozens (depends on sizes and color); plastic scrap – 30/kg; nylon – 12/kg; aluminum (including some beverage cans) – 50/kg; copper (wire) – 800/kg; brass – 400/kg; steel – 30/kg; zinc – 50/kg; stainless metal – 80/kg; electronics (including computer panel) – 800/kg; sacs – 60/dozen; carpet – 20/kg; and Rug – 10/kg. The prices of the recyclables depend on demand from industrialists who use recyclables as potential materials for manufacturing. Economic aspects of salvaging recyclables from dumpsites have been widely reviewed (Rettenberger 1995; Van der Zee et al. 2004). In these studies, possible costs and benefits that may be obtained from using dumpsite as material recovery centers were outlined on a large scale. Some of the benefits listed were revenue from recycled materials and saving land space at dumpsites to increase their life spans. Contrary to this observation, the economic feasibility of landfill mining could not be meticulously addressed by previous studies (Savage et al. 1998; Cossu et al. 1996), and in some studies, such initiatives have been considered nonbeneficial (Cobb and Ruckstuhl 1988; Bryden 2000).

At all the dumpsites, more males were found than females because more physical strength required for the job was attributed to males and that females were usually discouraged by the stigmatization attached to the work by the people. The discussants were satisfied with their job because of their achievements and sustainable daily income from the sale of recyclables.

### **Method of Business Apprenticeship**

The waste pickers could not identify any method of apprenticeship during the discussion. The majority of them joined the business haphazardly; they associated their enrolment into the job with severe financial problems and bankruptcy. Their main plan was to leave the job as soon as they recovered from insolvency. Contrarily, having tasted the good returns from the job, they found it difficult to go, even after they had overcome their financial burdens. The waste pickers said further that the business required little or no capital to start with and the principal instrument required was a picker. They did not register with any government agency or ministry. As such, there was no monitoring from the government or any nongovernment organization.

### **Factors That Affect the Operation of Waste Pickers**

Among other things, almost all of the discussants listed the following as significant constraints they faced in the job: lack of proper and controlled tipping that sometimes leads to site congestion and open burning, disturbances from environmental health officers who usually extort money from them, odor and flies from abattoir waste, transportation, lack of business regulation, and fire outbreak. Other constraints cited were sickness (mostly from fever, body pains, whitlow, and laceration) as well as smoke, and flies and odor problems. When asked about steps taken for their preventive measures, many of them used self-medication. Besides, almost all of the discussants did not use Personal Protective Equipment (PPE), claiming that the use of PPE was not convenient to them and that they lacked financial capability to do so. This practice may have a profound effect on their health and well-being. Most of the waste composition studies address environmental and safety issues at dumpsites (Hogland et al. 1995; Cossu et al. 1995; Zhao et al. 2007; Prechthai et al. 2008) and show that the practices at municipal dumpsites are not effective. Many of the dumpsites have no fence, allowing unregulated access to the site and dumping of restricted materials, such as toxic wastes. Additionally, owing to the poor control of activities at dumpsites, medical and hazardous wastes end up at those dumpsites even though there are no particular dumping areas for such wastes in the city.

### **Perception of the Waste Pickers on Business Optimization and Improvement**

Suggestions on how the job can be improved were sought from the waste pickers. Very few of them that responded said the government should absorb them into the civil service, give them proper training, especially on waste recycling, and support them with necessary facilities. Also, the discussants thought that the marketing of the recyclables could be improved significantly if the government could purchase the recyclables from them and act as a wholesaler. According to Mocker et al. (2009), due to the increasing scarcity and costs of different raw materials, the recovery of recyclables from dumpsites as a source for raw materials is rising steadily.

### **Quantity of Waste Picking Per Month at the Four Dumpsites**

The output, in terms of quantities of recyclables salvaged per month for the four sites, is represented in Fig. 7. The most purchased component was plastics, followed by paper and organic waste. Rugs and electronics were found at the lowest proportions. The thin film and organic waste were not sorted, though they equally had high recycling potentials. According to the participants, "*Organic waste was messy and very difficult to deal with*"; *it could not be stored without much problem, especially those related to odor and flies nuisance*. Besides, thin film such as pure water sachets remained very common; it could be found anywhere and everywhere without stress, leading to its low offered price. Waste components such as disused mattresses and packaging plastic foams had very little or no secondhand values; they could instead be reused than recycled. Also, an individual waste picker was assigned with a specific type of recyclable, and the number of waste pickers working at each site reflected the quantities of recyclables obtainable at such site.

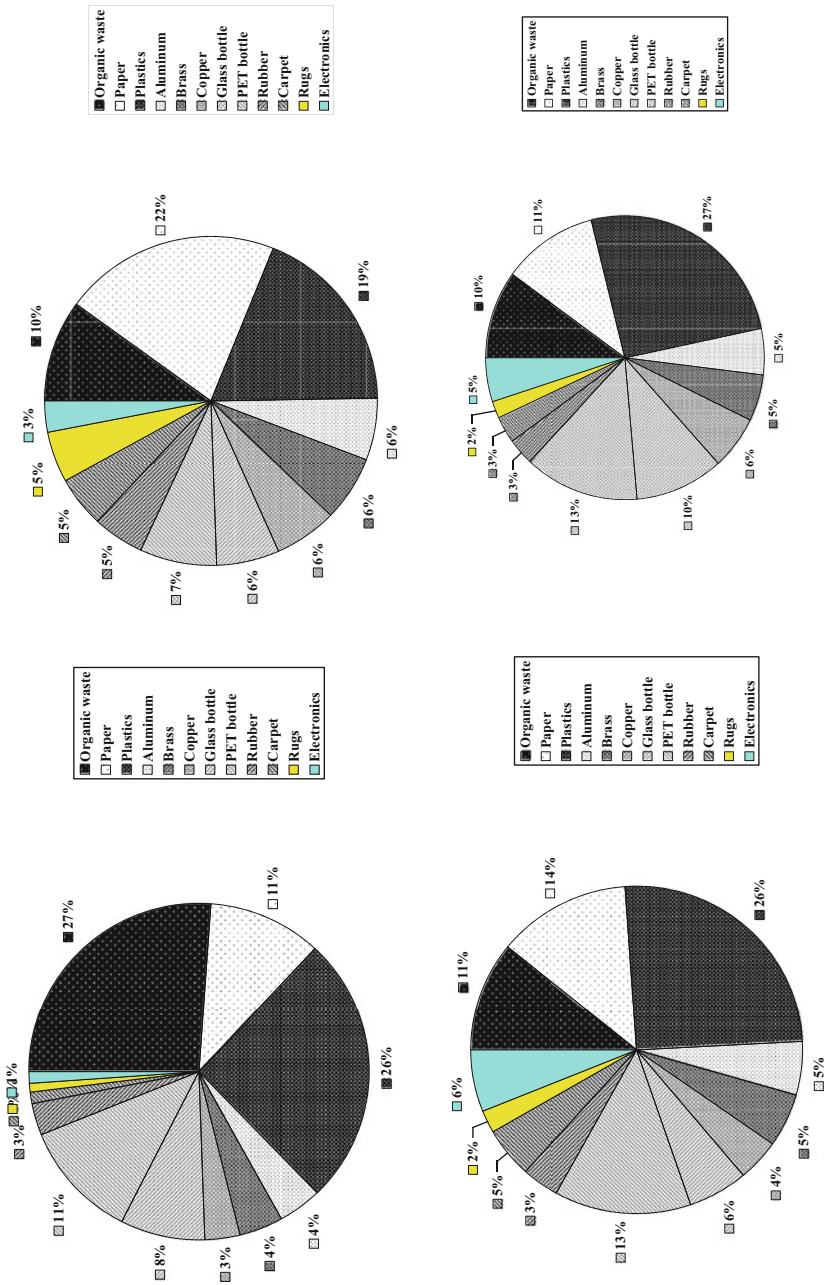


Fig. 7 Quantity of recyclables at the four dumpsites per month. Left top (Lapite); Left bottom (Afonfura); Right top (Awotani); Right bottom (Ajakanga)

## Conclusion

The rate at which climate change affects developing economies has called for urgent measures to cope with unexpected climate phenomena. Climate change effects threaten to exacerbate existing vulnerabilities and pose unprecedented challenges and opportunities for people in this part of the world. Based on these premises, this chapter describes grassroots projects and the diversity of approaches to climate change management. Apart from the results of research and field projects, this section also showcases practice-oriented procedures, case studies, innovative local adaptation practices as well as barriers and limits to climate change management. The contents are expected to foster resilience and capacity building among communities in developing countries.

---

## References

- Ana PGP, Betania HL, Rubens MF (2013) Application of biomass to hydrogen and syngas production. *Chem Eng Trans* 32:589–594
- Ashton W, Chertow M, Shenoy M (2009) Industrial ecology – developing systemic solutions to climate change and other environmental challenges in Indian industry. *Sustain Tomorrow* 4(4): 48–55
- Bachmann M, Cordes M (2007) Das Rohstoffpotential von Altdeponien aus wirtschaftlicher Sicht (the raw material potential of old dumpsites). In: Wiemer K, Kern M (eds) *Bio- und Sekundärrohstoffverwertung II*. Witzenhausen-Institut für Abfall, Umwelt und Energie GmbH, Witzenhausen, pp 857–869
- Bailis R, Ezzati M, Kammen DM (2005) Mortality and greenhouse gas impacts of biomass and petroleum energy futures in Africa. *Science* 308:98–103
- Baumlin S, Broust F, Bazer-Bachi F et al (2006) Production of hydrogen by lignins fast pyrolysis. *Int J Hydrogen Energy* 31:2179–2192
- Bouros D, Samiou MF (2001) Short-term effects of wood smoke exposure on the respiratory system among charcoal production workers. *CODEN CHETBF* 119(4):1260–1265
- Bryden G (2000) Factors influencing the feasibility of wood products in landfill waste recovery for beneficial re-use. In: *Proceedings of the 2000 TAAPI international environmental conference & exhibition*, Denver, pp 527–535
- Chang ACC, Chang HF, Lin FJ et al (2011) Biomass gasification for hydrogen production. *Int J Hydrog Energy* 36:14252–14260
- Chertow MR (2009) The ecology of recycling. *The UN Chronicle online*, special climate change issue 2009
- Chertow MR, Lombardi DR (2005) Quantifying economic and environmental benefits of co-located firms. *Environ Sci Technol* 39(17):6535–6541
- Cobb CE, Ruckstuhl K (1988). Mining and reclaiming existing sanitary landfills. In: *Proceedings of the national waste processing conference*, Detroit, pp 145–151
- Cossu R, Motzo GM, Laudadio M (1995) Preliminary study for a landfill mining project in Sardinia. In: *Proceedings Sardinia 95, fifth international landfill symposium*, Cagliari, pp 841–850
- Cossu R, Hogland W, Salerni E (1996) Landfill mining in Europe and the USA. *ISWA Tear Book*, pp 107–114
- Da Costa JL, Navarro A, Neves JB et al (2004) Household wood and charcoal smoke increases the risk of otitis media in childhood in Maputo. *Int J Epidemiol* 33(3):573–578
- Dehoust et al (2005) Status report on the waste sector's contribution to climate protection and possible potentials. Commissioned by the German Federal Environmental Agency, Berlin

- European Environment Agency (EEA) (2003) Europe's environment: the third assessment. Environmental assessment report no 10, vol 7. EEA, Copenhagen, pp 151–164
- Fauzul RS, Viradin Y (2011) Community participation as community-based integrated waste management. *International Journal of Academic Research* 3(2):434–441
- Gwatkin DR, Rutstein S, Johnson K et al (2000) A. Socio-economic differences in health, nutrition, and population. HNP/poverty thematic group. World Bank, Washington, DC
- Hammed TB, Sridhar MKC, Olaseha IO et al (2012) Community perceptions on a government-provided integrated-waste recycling plant: experience from Ibadan, Nigeria. *Int J Sci Soc* 3(3): 145–158
- Hammed TB, Shem OW, Yacob M et al (2018) Improving knowledge and practices of mitigating green house gas emission through waste recycling in a community, Ibadan, Nigeria. *Waste Manag* 81:22–32
- Harris P (1999) On charcoal. *Interdiscip Sci Rev* 24:301–306
- Hogland W, Jagodzinski K, Meijer JE (1995) Landfill mining tests in Sweden. In: *Proceedings Sardinia '95, fifth international landfill symposium, Cagliari*, pp 783–794
- IPCC (2006) IPCC guidelines for national greenhouse gas inventories. In: Eggleston HS, Buendia L, Miwa et al (eds) Prepared by the national greenhouse gas inventories programme. IGES, Japan
- Karve AD (2006) Briquette charcoal from sugarcane trash. Drupal, Belgium
- McDonald S, Ball R (1998) Public participation in plastics recycling schemes. *Resour Conserv Recycl* 22:123–141
- Mocker M, Fricke K, Löh I (2009) Urban Mining – Rohstoffe der Zukunft (Urban mining – raw materials for the future). *Müll und Abfall – Fachzeitschrift für Abfall- und Ressourcenwirtschaft* 42(10):492–501
- Ojolo SJ (2004) Conversion of municipal solid wastes into medium grade fuel and industrial raw materials in Lagos Island. PhD thesis, University of Ibadan
- Oluwole O, Otaniyi OO, Olopade CO (2012) Indoor air pollution from biomass fuels: a major health hazard in developing countries. *J Public Health* 20. <https://doi.org/10.1007/s10389-012-0511-1>
- Paula U, Elizabeth R (2008) Factors influencing households' participation in recycling. *Waste Manag Res* 26(2):140–146
- Prechthai T, Padmasri M, Visvanathan C (2008) Quality assessment of mined MSW from an open dumpsite for recycling potential. *Resour Conserv Recycl* 53:70–78
- Rettenberger G (1995) Results from a landfill mining demonstration project. In: *Proceedings Sardinia '95, fifth international landfill symposium, Cagliari, Italy*, pp 827–840
- Salvi S, Barnes P (2010) Is exposure to biomass smoke the biggest risk factor for COPD globally? *Chest* 138(1):3–5
- Savage GM, Diaz LF, Golueke GC (1998) Guidance in landfilling waste in economically developing countries. US Environmental Protection Agency, Cincinnati, p 467
- Sharma P, Fulekar MH, Pathak B (2012) E-waste- a challenge for tomorrow. *Res J of Rec Sci* (3):86–93
- Smith AK, Brown S, Ogilvie K et al (2001) Waste management options and climate change. Final Report ED21158R4.1 to the European Commission, DG Environment, AEA Technology, Oxfordshire, 205 pp
- Sridhar MKC, Hammed TB, Anthony O (eds) (2016) *Entrepreneurship in waste recycling*. Book Builders, Ibadan. 750 pp
- The Guardian (2015) UNHabitat sets seven-point agenda to transform Nigerian cities. <https://guardian.ng/property/unhabitat-sets-seven-point-agenda-to-transform-nigerian-cities/>. Accessed 25 Feb 2020
- Tucker P, Lamont J, Murray G (1998) Predicting recycling scheme performance: a process simulation approach. *J Environ Manag* 53:31–48
- UNEP (2010) *Waste and climate change: global trends and strategy framework*. United Nations Environmental Programme Division of Technology, Industry and Economics, International Environmental Technology Centre, Osaka/Shiga

- US Environmental Protection Agency (2006) Solid waste management and greenhouse gases: A life cycle assessment of emissions and sinks, 3rd ed. US Environmental Protection Agency, Washington
- Van der Zee DJ, Achterkamp MC, de Visser BJ (2004) Assessing the market opportunities of landfill mining. *Waste Manag* 24:795–804
- Zerbock O (2003) Urban solid waste management: waste reduction in developing nations (written for the requirements of CE 5993 field engineering in the developing world). Michigan Technological University, Houghton, pp 89–105
- Zhao Y, Song L, Huang R (2007) Recycling of aged refuse from a closed landfill. *Waste Manage Res* 25:130–138
- Zhou CH, Beltramini JN, Fab YX, LU GQ (2008) Chemoselective catalytic conversion of glycerol as a bio-renewable source to valuable commodity chemicals. *Chem Soc Rev* 37:527–549

**Open Access** This chapter is licensed under the terms of the Creative Commons Attribution 4.0 International License (<http://creativecommons.org/licenses/by/4.0/>), which permits use, sharing, adaptation, distribution and reproduction in any medium or format, as long as you give appropriate credit to the original author(s) and the source, provide a link to the Creative Commons license and indicate if changes were made.

The images or other third party material in this chapter are included in the chapter's Creative Commons license, unless indicated otherwise in a credit line to the material. If material is not included in the chapter's Creative Commons license and your intended use is not permitted by statutory regulation or exceeds the permitted use, you will need to obtain permission directly from the copyright holder.



# Pyrolysis Bio-oil and Bio-char Production from Firewood Tree Species for Energy and Carbon Storage in Rural Wooden Houses of Southern Ethiopia

# 64

Miftah F. Kedir

## Contents

Introduction .....	1314
Material and Methods .....	1316
Description of the Study Area .....	1316
Methods of Data Collection and Analyses .....	1317
Results .....	1321
Bio-oil and Bio-char Yield of Different Woody Biomasses Species .....	1321
Calorific Value and Moisture Content of Bio-oil and Bio-char in Comparison with the Parent Firewood .....	1321
Fixed Carbon, Volatile Matter, and Moisture Content of Different Tree Species Bio-chars .....	1323
The Potential of Pyrolysis Oil and Bio-char in Reducing Firewood End Use Emission .....	1324
Discussion .....	1325
Conclusion and Recommendation .....	1327
References .....	1327

## Abstract

The need for emission reduction for climate management had triggered the application of pyrolysis technology on firewood that yield bio-oil, bio-char, and syngas. The purpose of present study was to select the best bio-oil and bio-char producing plants from 17 firewood tree species and to quantify the amount of carbon storage. A dried and 1 mm sieved sample of 150 g biomass of each species

This chapter was previously published non-open access with exclusive rights reserved by the Publisher. It has been changed retrospectively to open access under a CC BY 4.0 license and the copyright holder is “The Author(s)”. For further details, please see the license information at the end of the chapter.

M. F. Kedir (✉)

WGCFNR, Hawassa University, Shashemene, Ethiopia

Central Ethiopia Environment and Forest Research Center, Addis Ababa, Ethiopia

© The Author(s) 2021

W. Leal Filho et al. (eds.), *African Handbook of Climate Change Adaptation*,  
[https://doi.org/10.1007/978-3-030-45106-6\\_183](https://doi.org/10.1007/978-3-030-45106-6_183)

1313



was pyrolyzed in assembled setup of tubular furnace using standard laboratory techniques. The bio-oil and bio-char yields were 21.1–42.87% (w/w) and 23.23–36.40% (w/w), respectively. The bio-oil yield of *Acacia seyal*, *Dodonea angustifolia*, *Euclea schimperi*, *Eucalyptus globulus*, *Casuarina equisetifolia*, and *Grevillea robusta* were over 36% (w/w), which make the total yield of bio-oil and bio-char over 62% (w/w) of the biomass samples instead of the 12% conversion efficiency in traditional carbonization. The calorific value of firewood was 16.31–19.66 MJ kg<sup>-1</sup> and bio-oil was 23.3–33.37 MJ kg<sup>-1</sup>. The use of bio-oil for household energy and bio-char for carbon storage reduced end use emission by 71.48–118.06%, which could increase adaptation to climate change in comparison to open stove firewood by using clean fuel and reducing indoor pollution.

### Keywords

Bio-char · Bio-oil · Deforestation · End use emission · Woody biomass

## Introduction

The adaptation and mitigation of climate change and energy security requires alternative energy sources that reduce emission of greenhouse gasses (GHG) in the place of fossil fuel dominant economy of the world (Krajnc et al. 2014). Liquid biofuel production from biomass pyrolysis is new form of the old technology that reduces waste and improves the low bulk density, high moisture content, hydrophilic nature, and low calorific value of firewood (Arias et al. 2008). Pyrolysis is a thermochemical process of converting biomass in to solid bio-char, liquid bio-oil (also called pyrolysis oil), and syngas in the absence of oxygen at 300–1000 °C, heating rate 0.1–1000 °C s<sup>-1</sup>, and vapor residence time 0.5–1800 s (Granada et al. 2013). Pyrolysis of dry biomass (C<sub>6</sub>H<sub>10</sub>O<sub>5</sub>) produces combustible gases (H<sub>2</sub>, CH<sub>4</sub>, CO) and noncombustible gases (CO<sub>2</sub> and H<sub>2</sub>O) resulting in condensable gases forming bio-oil (C<sub>6</sub>H<sub>8</sub>O with H<sub>2</sub>O) (Cordeiro 2011). High heating rates above 500 °C and short vapor residence time gives more pyrolysis oil; and low temperature below 400 °C produces more bio-char (Xiu and Shahbazi 2012).

Feedstocks for pyrolysis can be a variety of woody and non-woody biomasses, forest products, solid organic wastes, forest/agricultural residues, paper and cardboard except toxic biomasses that have heavy metals, polyaromatic hydrocarbons, and dioxins (Garcia-Perez 2008).

The calorific value of bio-oil can be chemically upgraded to 44 MJ kg<sup>-1</sup> (Elliot 2012). Firewood combustion pollutes indoor air and affects health but bio-oil has no significant health, environment, or safety risks and its GHG emission is lower than petro diesel and gasoline (Shimelis 2011).

Bio-char and charcoal are similar products of pyrolysis technology that are used for different purpose. Bio-char is charcoal like, fine porous structured, positively charged, high carbon and low moisture containing co-product of bio-oil but charcoal

is coarse structure as a sole product. Bio-char could be used for energy supply, soil carbon storage, and fertility amendment but charcoal is usually used for energy.

The pyrolysis of organic matter alters the chemical structure of carbon to aromatic carbon rings called recalcitrant carbon that resist microbial decomposition. Wood bio-char stores 25–50% of its carbon for millennia, 100–1000 years but organic residue compost stores 10–20% of its carbon from weeks to 5–10 years (Kannan et al. 2013).

Capturing the volatiles during pyrolysis to get bio-oil, in addition to bio-char and syngas instead of mere charcoal, is an increment of conversion efficiency of carbonization in traditional charcoal making (Brown 2009). Charcoal making emits primary GHG of the energy system, carbon monoxide, ethane, pyroacids, tars, heavy oils, and water (Bird et al. 2011). Firewood and charcoal have CO<sub>2</sub> emission factors of 112,000 kg TJ<sup>-1</sup> on net calorific value basis (IPCC 2006). About 1788±337 g CO<sub>2</sub> and 32±5 g CH<sub>4</sub> per kilogram of charcoal are produced, which varies with different vegetation parts and burning conditions (Chidumayo and Gumbo 2013). In charcoal making the three steps include wood sourcing, carbonization, and end use, and the emission is 29–61%, 28–61%, and 9–18%, respectively (FAO 2017).

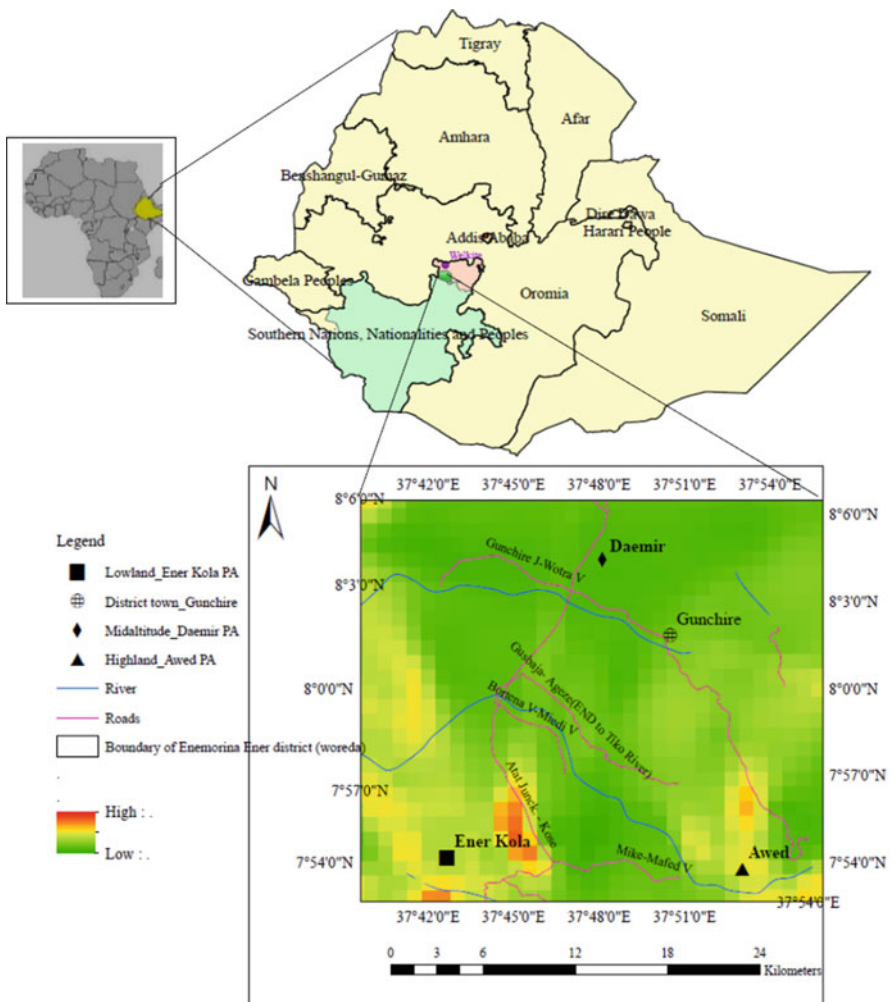
Climate change adaptation to energy is the adjustment in natural or human systems in response to actual or expected energy deficit of climatic stimuli or their effects, which moderates harm or exploits beneficial energy production opportunities. Ethiopia in particular and Africa in general have low adaptation capability to climate change (IPCC 2006). The conversion of firewood and charcoal in to multiple products of bio-char, bio-oil, and syngas reduces consumption of biomass that reduces deforestation and increases income sources in order to adapt to climate change. In Ethiopia and elsewhere in Africa, adapting technology for alternative sources of bioenergy is one of the strategies of climate change adaptation (FAO 2017). Environmental sustainability could be achieved by local management of firewood saving and macro policy adjustment in order to promote the sustainability of land resources and climate change adaptation (Eze et al. 2020). Therefore, developing biomass saving technologies like pyrolysis is important for climate change adaptation and mitigation.

Pyrolysis oil during biomass carbonization can be produced over a wider range of temperature above 300 °C by screening a large number of biomass yielding trees (Xiu and Shahbazi 2012). According to Okoroigwe et al. (2015) tropical woody biomass produces up to 66% (w/w) bio-oil for energy and it contains industrially useful chemicals. Bio-oil production is an attractive venture with significant commercial application and value, and dry feed can produce up to 80% (w/w) bio-oil. However, there is dearth of information on condensing the volatile matters to bio-oil, especially at 600 °C and residence time of 2 s in Ethiopia for firewood species, except *Catha edulis* (Yishak 2014). In fact, it is studied that biomass residues at 600 °C has high recalcitrant character and low volatile nature (Jindo et al. 2014). One of the most important characteristics of biomass fuel is heating value which can be determined experimentally by adiabatic bomb calorimeter (Sheng and Azevedo 2005), which was not available for many of the firewood tree species in Ethiopia. The purpose of the present study was to inform tree selection in plantation development by the bio-oil and bio-char yield, and by their carbon storage potential in selected firewood utilizing rural households of Southern Ethiopia.

## Material and Methods

### Description of the Study Area

Biomass samples of fire wood species were collected in Southern Ethiopia, three agro-ecologies of Enemorina Ener district (county). From each agro-ecology a representative peasant association (PA) or Kebele (lowest administrative unit) was sampled. In lowland agro-ecology, 500–1600 m altitude above sea level (asl), Ener Kola PA; in midaltitude agro-ecology, 1600–2400 m altitude asl, Daemir PA; and in highland agro-ecology, 2400–3200 m asl, Awed PA were selected (Fig. 1). The local



**Fig. 1** Location map of most samples collected areas. (The legend and scale refers only to the three studied peasant associations or Kebeles and nearby features)

people had been practicing mixed farming, trading, and pottery work. The main fuel for cooking was firewood with or without kerosene light.

## Methods of Data Collection and Analyses

### Field Sample Collection

Woody biomass samples were collected from the selected PAs after interviewing 5–10 key informants, and district energy offices about the preferred firewood tree species that ranked 1–5. The most preferred tree species were selected for pyrolysis test in each agro-ecology; seven species in lowland and midaltitude each and one species in highland. Additional samples from two species (*Catha edulis* and *Prosopis juliflora*) were obtained from other places (Table 1) because of their abundance and common firewood value for comparison purposes, making a total of 17 species. That is *C. edulis* is abundant throughout Ethiopia and *P. juliflora* is an invasive species used for charcoal making in North Eastern Ethiopia. The family, diameter at breast height (DBH), and total mean height (*H*) of the selected species are given in Table 1.

From the 15 tree species in the forest, three standing trees were randomly selected and cut from each. Then the wood without debarking was chipped in to 1–5 cm long pieces by excluding branches ( $\leq 5$  cm diameter) and leaves. In *C. edulis*, leafy residues and in *C. megalocarpus*, fruit pod were collected. Then the 17 tree species biomass samples were air dried, separated from any impurities, ground, and sieved by 1 mm sieve size.

### Experimental Analyses

Pure, composite, ground, dry biomass samples of 150 g were pyrolyzed in assembled setup of tubular furnace in three replications. The pyrolysis was done at 600 °C temperature, at a heating rate of 100 °C min<sup>-1</sup> and 2 s vapor residence, using 1.5 atmosphere inert nitrogen gas with 20–25 mL min<sup>-1</sup> flow rate. The setup consisted of feeder, reactor, glass liquid collecting condenser, and chiller (Fig. 2). Only bio-oil and bio-char were collected. The weight of bio-char and bio-oil was measured with balance (Adam Lab.equipment Leicester LE67FT-England, 0.001 g) and volume by graduated cylinder. The yield of bio-char and bio-oil was determined from the proportion of dried biomass feedstock pyrolyzed (Eq. 1) and loss by deduction (Eq. 2). The percentage throughout this chapter is given as (%) for percent weight to weight (% w/w) or % (w/w) or %, unless otherwise specified as percent volume to volume as (% v/v) or % (v/v).

$$\text{Yield of biooil or biochar} \left( \%, \frac{w}{w} \right) = \left( \frac{W \text{ of biooil or biochar (g)}}{W \text{ of pyrolysed feedstock (g)}} \right) \times 100 \quad (1)$$

$$\text{Biochar} \left( \%, \frac{w}{w} \right) + \text{Biooil} \left( \%, \frac{w}{w} \right) + \text{NCG} \left( \%, \frac{w}{w} \right) = 100 \left( \%, \frac{w}{w} \right) \quad (2)$$

**Table 1** Description of sampled tree species for firewood, bio-oil, and bio-char production

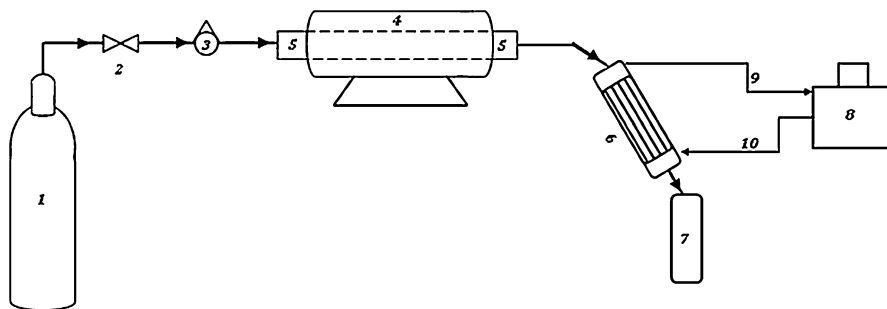
Species	Family	Sample of collection			Sources
		Agro-ecology	Mean DBH (cm)	Mean <i>H</i> (m)	
<i>Acacia albida</i> (Delile) Chev.	Fabaceae	Lowland	16.07	12.3	Bekele (2007)
<i>Acacia seyal</i> Delile	–	Lowland	17.8	14.1	–
<i>Acokanthera schimperi</i> (A. DC.) Schweinf.	Apocynaceae	Lowland	10.73	7.9	–
<i>Combretum collinum</i> , Fresen.	Combretaceae	Lowland	10.08	6.9	–
<i>Euclea schimperi</i> (A.DC.) Dandy	Ebenaceae	Lowland	11.97	10.5	–
<i>Casuarina equisetifolia</i> L.	Casuarinaceae	Lowland	21.3	15.5	–
<i>Dodonaea angustifolia</i> L.f.	Sapindaceae	Lowland	4.12	4.00	–
<i>Acacia abyssinica</i> Hochst. ex Benth	Fabaceae	Midaltitude	24.5	12.0	–
<i>Acacia decurrens</i> Willd.	Fabaceae	Midaltitude	27.5	11.5	–
<i>Cupressus lusitanica</i> Mill.	Cupressaceae	Midaltitude	24.6	15.5	–
<i>Catha edulis</i> (Vahl.) Endl.	Celastraceae	Midaltitude	–	–	–
<i>Eucalyptus camaldulensis</i> Dehnh.	Myrtaceae	Midaltitude	21.5	16.0	–
<i>Grevillea robusta</i> A.Cunn. ex R.Br.	Proteaceae	Midaltitude	20.5	14.5	–
<i>Pinus patula</i> Schldl. et Cham.	Pinaceae	Midaltitude	19.3	15	–
<i>Eucalyptus globulus</i> Labill.	Myrtaceae	Highland	27.3	12.5	–
<i>Prosopis juliflora</i> (Sw.) DC.	Fabaceae	Afar	22.5	17.5	–
<i>Croton megalocarpus</i> Hutch.	Euphorbiaceae	Hawassa city	10.5	6.5	Aliyu et al. (2010)

where *W* is weight; NCG is non-condensable gas by considering that all condensable gases were condensed.

The bio-oil was degummed in 3% (v/v) distilled water and centrifuged at 2000 rpm for 20 min. The moisture content was determined gravimetrically by taking 5 g bio-oil by heating at 105 °C in oven up to constant weight (Eq. 3).

$$\text{MC} \left( \%, \frac{w}{w} \right) = \left( \frac{(W \text{ of initial sample (g)} - W \text{ of sample at } 105^\circ\text{C (g)})}{W \text{ of initial sample (g)}} \right) \times 100 \quad (3)$$

where MC is moisture content; *W* is weight.



**Fig. 2** Simplified system of pyrolysis, assembled setup of tubular furnace

**Legend** (not to scale):

1. N<sub>2</sub> gas containing cylinder; 2. Valve; 3. Pressure gauge; 4. Tubular furnace; 5. Stainless steel tube (inserted into the furnace); 6. Glass condenser; 7. Condensate collector; 8. Chiller; 9. Hot water to chiller; 10. Cooling water (at 4 °C) to condenser

The bio-oil and parent firewood Gross Calorific Value (GCV) was determined by adiabatic oxygen bomb calorimeter (Parr<sup>®</sup> model no.1241EF adiabatic calorimeter S.no. 5172, 115 v, 50 Hz, 2.0 Amps, Parr Instrument Company). About 1 g sample and oxygen filled bomb at 30 atmospheres were used. GCV was converted to net calorific value (NCV) by multiplying with 0.95 and 0.80 for oil and dry woody biomass, respectively (Forest Products Laboratory 2004). Ash content of firewood and bio-oil was determined by burning 5 g sample in furnace at 600 °C for 4 h.

Bio-char samples were characterized using proximate analysis (ASTM 1989) to obtain fixed carbon, moisture content (D3173), ash content (D3174), and volatile matter (D3175). Moisture content of bio-char was determined by drying 1 g initial sample in oven at 105 °C to constant weight for 3 h (Eq. 3); volatile matter by heating 1 g moisture free sample at 950 °C for 6 min (Eq. 4); ash content by heating 1 g sample at 750 °C for 3 h (Eq. 5) and fixed carbon by deduction (Eq. 6).

$$Vm \left( \%, \frac{w}{w} \right) = \left( \frac{W \text{ of sample at } 105^{\circ}\text{C} (g) - W \text{ of sample at } 950^{\circ}\text{C} (g)}{W \text{ of initial sample} (g)} \right) \times 100 \quad (4)$$

$$\text{Ash} (A) \left( \%, \frac{w}{w} \right) = \left( \frac{W \text{ of sample at } 750^{\circ}\text{C} (g)}{W \text{ of initial sample} (g)} \right) \times 100 \quad (5)$$

$$\text{Fixed carbon of biochar} \left( \%, \frac{w}{w} \right) = (100 - (\text{MC}, \% + \text{Vm}, \% + A, \%)) \quad (6)$$

where MC is moisture content; *W* is weight; Vm is volatile matter; *A* is ash content

The common GHG (CO<sub>2</sub>, CH<sub>4</sub>, and N<sub>2</sub>O) emissions in rural wooden houses were determined based upon NCV (IPCC 2006) of bio-oil and firewood with or without kerosene. Although emission exists throughout the life cycles of these fuels, from

**Table 2** Emission factors and global warming potential of common GHGs from different fuels

Type of GHG	Residential source of Gas Emission Factors on a net calorific basis (Stationary Combustion) (IPCC 2006) (kg TJ <sup>-1</sup> )				GWP (100-year time horizon)
	Firewood in conventional stove	Bio-oil (other liquid biofuels)	Charcoal	Other kerosene	
CO <sub>2</sub>	112000	79600	112000	71900	1
CH <sub>4</sub>	210	10	330.5	10	23
N <sub>2</sub> O	4	0.6	1.6	0.6	296

planting, woody biomass harvesting to consumption, the present study's concern of indoor pollution reduction dealt the emission only at the end use or consumption. The IPCC default emission factors were applied (Eqs. 7 and 8). The GHGs were converted to carbon dioxide equivalent (CO<sub>2</sub><sup>e</sup>) using the global warming potential (GWP) of each gas (Table 2).

The average end use emission of firewood and bio-oil combustion and bio-char soil carbon accumulation was determined. For comparison purpose, the daily consumption of firewood and kerosene at household level in each agro-ecology was obtained from Miftah et al. (2017). It was assumed that a household consumes the same amount of energy in using firewood alone, firewood with kerosene or bio-oil.

The carbon storage of bio-char was determined by its fixed carbon content (Eq. 9). Stable carbon fraction to be stored for over a century used 80% factor (Roberts et al. 2010). In the presence of modern pyrolysis reactor 75% bio-oil and 12% bio-char yield was assumed to be produced from woody biomass (Granada et al. 2013). The total energy of the fuels was determined by the dried weight of the fuel and their calorific value (ASTM 1989).

The emission from firewood combustion in conventional wood stove using IPCC (2006) was calculated as Eq. 7.

$$\mathbf{Wd\ em} = \sum_i^k \mathbf{Wd\ cons}_{(ijk)} \times \mathbf{EF}_{(ijk)} \times \mathbf{GWP}_{(ijk)} \quad (7)$$

where Wd em is emission of GHG (kgCO<sub>2</sub><sup>e</sup>) from firewood combustion; Wd cons is firewood consumption in net calorific value (TJkg<sup>-1</sup>); EF is emission factor of firewood on net calorific value basis (kgTJ<sup>-1</sup>); and GWP is global warming potential of a given gas on 100 years; *i* is CO<sub>2</sub>; *j* is CH<sub>4</sub>, and *k* is N<sub>2</sub>O.

The emission from bio-oil combustion in stove using IPCC (2006) was calculated as Eq. 8.

$$\mathbf{Bo\ em.} = \sum_i^k \mathbf{Bo\ cons}_{(ijk)} \times \mathbf{EF}_{(ijk)} \times \mathbf{GWP}_{(ijk)} \quad (8)$$

where Bo em is emission of GHG (kgCO<sub>2</sub><sup>e</sup>) from bio-oil combustion; Bo cons is bio-oil consumption in net calorific value (TJkg<sup>-1</sup>); EF is emission factor of bio-oil

on net calorific value basis ( $\text{kgTJ}^{-1}$ ); and GWP is global warming potential of a given gas on 100 years basis;  $i$  is  $\text{CO}_2$ ;  $j$  is  $\text{CH}_4$  and  $k$  is  $\text{N}_2\text{O}$ .

Carbon storage in bio-char of organic wastes was calculated as Eq. 9.

$$\text{Csb (g)} = (\text{dry biomass (g)}) \times (\text{biochar yield (\%)}) \times (\text{fixed C (\%)}) \quad (9)$$

where Csb is carbon storage in bio-char.

## Results

### Bio-oil and Bio-char Yield of Different Woody Biomasses Species

The bio-oil (Fig. 3) yield of woody biomass samples ranged from 23.03 (% w/w) in *A. schimperi* to 42.9 (% w/w) in *E. globulus* which was statistically different at  $p < 0.05$  (Table 3). The bio-oil yield of fruit pod of *C. megalocarpus* was about 21.1 (% w/w), lower than the other woody biomasses; and the leaf of *C. edulis* was intermediate about 25.83 (% w/w). Tree species like *E. globulus*, *A. seyal*, *D. angustifolia*, *E. schimperi*, and *G. robusta* produced greater amount of bio-oil (Table 3) and highly preferred for firewood (Table 3).

The bio-char (Fig. 4) yield of the biomass samples ranged from 23.2% (w/w) in *E. camaldulensis* to 36.4% (w/w) in *C. edulis* which was statistically different at  $p < 0.05$  (Table 3). The mass losses of pyrolysis product ranged from 31.23% (w/w) in *E. schimperi* to 46.37% (w/w) in *A. schimperi* (Table 3), which could be attributed to the specific characteristics of the species.

### Calorific Value and Moisture Content of Bio-oil and Bio-char in Comparison with the Parent Firewood

The calorific value of firewood used for the pyrolysis process ranged from  $16.31 \text{ MJkg}^{-1}$  (in *E. schimperi*) to  $19.66 \text{ MJkg}^{-1}$  (in *P. julifolia*) at moisture content



**Fig. 3** Bio-oil from pyrolysis of woody biomass



**Table 3** Bio-oil and bio-char yield of different woody plant species

Species	Yield (Mean±Stand. err.) (% , w/w)		Priority as firewood <sup>g</sup>
	Bio-oil	Bio-char	
<i>A. abyssinica</i>	29.067±3.254 <sup>abcd</sup>	31.367±1.717 <sup>bc</sup>	1
<i>A. albida</i>	33.433±1.802 <sup>abcd</sup>	30.567±0.769 <sup>bc</sup>	1
<i>A. decurrens</i>	33.533±3.641 <sup>abcd</sup>	30.233±0.555 <sup>bc</sup>	2
<i>A. schimperi</i>	23.033±2.567 <sup>ab</sup>	30.600±0.794 <sup>bc</sup>	4
<i>A. seyal</i>	39.000±1.808 <sup>cd</sup>	27.133±0.736 <sup>ab</sup>	1
<i>C. collinum</i>	31.633±3.537 <sup>abcd</sup>	30.933±1.212 <sup>bc</sup>	1
<i>C. edulis</i> <sup>e</sup>	25.833±2.634 <sup>abc</sup>	36.400±0.208 <sup>d</sup>	5
<i>C. equisetifolia</i>	36.067±4.390 <sup>abcd</sup>	27.100±0.173 <sup>ab</sup>	1
<i>C. lusitanica</i>	34.167±2.195 <sup>abcd</sup>	27.500±0.173 <sup>ab</sup>	3
<i>C. megalocarpus</i> <sup>f</sup>	21.100±1.200 <sup>a</sup>	33.300±1.700 <sup>c</sup>	3
<i>D. angustifolia</i>	38.033±0.219 <sup>cd</sup>	24.633±0.186 <sup>a</sup>	1
<i>E. camaldulensis</i>	32.767±1.139 <sup>abcd</sup>	23.233±0.841 <sup>a</sup>	1
<i>E. globulus</i>	42.867±0.888 <sup>d</sup>	25.733±1.033 <sup>a</sup>	1
<i>E. schimperi</i>	37.133±2.118 <sup>cd</sup>	31.633±1.650 <sup>bc</sup>	1
<i>G. robusta</i>	38.800±3.623 <sup>cd</sup>	25.267±0.219 <sup>a</sup>	2
<i>P. juliflora</i>	31.367±4.296 <sup>abcd</sup>	30.767±0.536 <sup>bc</sup>	3
<i>P. patula</i>	27.800±1.600 <sup>abc</sup>	27.600±1.900 <sup>ab</sup>	3

Note: <sup>a</sup>, <sup>b</sup>, <sup>c</sup>, and <sup>d</sup> are statistically different at  $p < 0.05$  of ANOVA

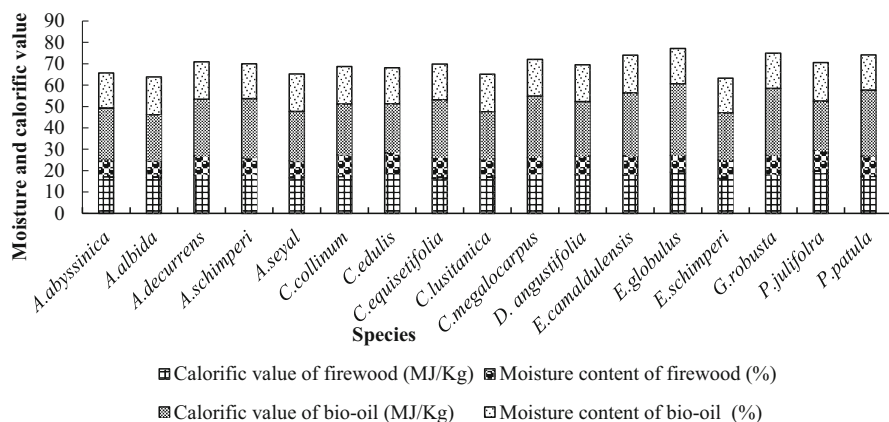
<sup>e</sup>Leaves

<sup>f</sup>Fruit pod

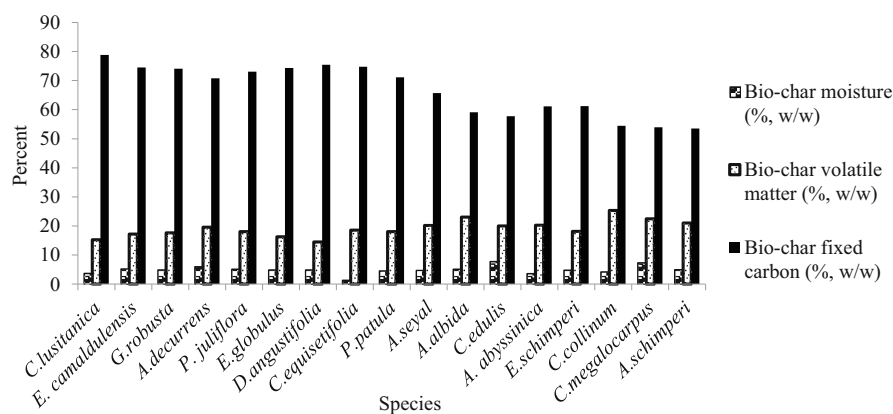
<sup>g</sup>Priority 1 is highly preferred and 5 is not

**Fig. 4** Bio-char from pyrolysis of woody biomass

of 7.92–10.22 (% , w/w) (Fig. 5). Firewood from *D. angustifolia*, *E. camaldulensis*, *G. robusta*, *A. decurrens*, and *E. globulus* had calorific value above 18 MJ kg<sup>-1</sup>. *C. edulis* leafy residues had comparable calorific value with the other firewood species (Fig. 5), but not used as firewood (Table 3) because of its smoke. The calorific value of bio-oil ranged from 21.43 MJkg<sup>-1</sup> (in *A. albida*) to 33.37 MJkg<sup>-1</sup> (in *E. globulus*) (Fig. 5).



**Fig. 5** The mean calorific value of parent firewood, bio-char, and bio-oil of a given plant species



**Fig. 6** Mean fixed carbon, volatile, and moisture content of bio-char

### Fixed Carbon, Volatile Matter, and Moisture Content of Different Tree Species Bio-chars

The fixed carbon content of bio-chars of the different tree species ranged from 53.48 (% w/w) (in *A. schimperi*) to 78.85 (% w/w) (in *C. lusitanica*); and volatile matter from 14.52 (% w/w) (in *D. angustifolia*) to 25.31 (% w/w) (*C. collinum*) (Fig. 6).

### Ash Content of Firewood Feedstock, and Bio-oil and Bio-char

The percentage of the ash content of the different tree species firewood and bio-oil was not consistently increasing or decreasing (Table 4). The ash in bio-char ranged from 2.27(% w/w) in *C. lusitanica* to 20.65 (% w/w) in *A. schimperi*. In firewood the ash content ranged from 0.434 (% w/w) in *E. camaldulensis* to 8.418 (% w/w) in *E. schimperi*. The lowest proportion of ash was obtained in bio-oil, ranging from

0.135% in *G. robusta* to 0.892% in *C. equisetifolia*. As the ash content of the firewood increases the ash content of the bio-char also increased (Table 4).

## The Potential of Pyrolysis Oil and Bio-char in Reducing Firewood End Use Emission

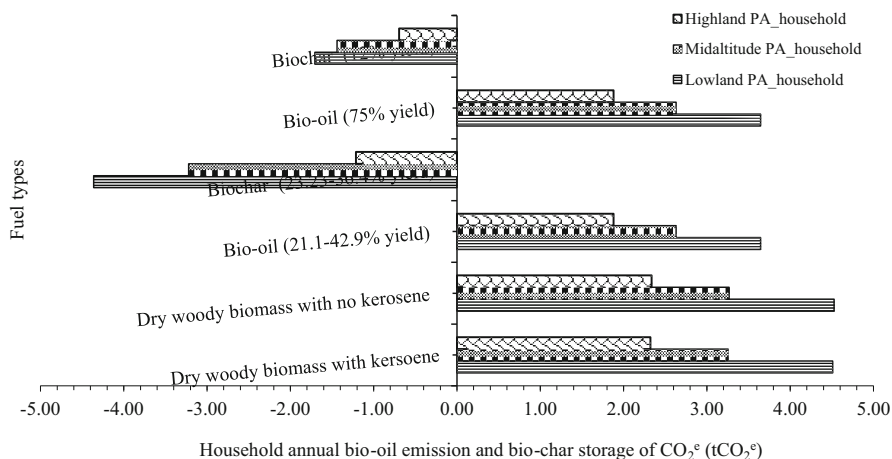
Rural households were using firewood and kerosene as energy sources. In the presence of kerosene, the amount of firewood biomass used was reduced, but both biomass and kerosene together during consumption emitted annually about 2.323–4.509 t CO<sub>2</sub><sup>e</sup> in each household. The end use emission from fire wood combustion was 2.335–4.527 t CO<sub>2</sub><sup>e</sup> year<sup>-1</sup> (Fig. 7), which could be reduced to 1.88–3.645 t CO<sub>2</sub><sup>e</sup> year<sup>-1</sup> in bio-oil heating in each household of the studied PAs. Moreover, bio-oil production has corresponding bio-char that can store carbon 1.214–4.363 t CO<sub>2</sub><sup>e</sup> year<sup>-1</sup> (Fig. 7) that makes the net emission of 0.67 to net storage of 0.72 t CO<sub>2</sub><sup>e</sup> year<sup>-1</sup>. The pyrolysis in the present study that produced bio-oil yield of 21–42.87% (w/w) as alternative energy for a household cooking and bio-char for carbon storage reduced end use emission by 71.48–118.06% in each household of the PAs when compared with the emission by firewood (Fig. 7). In using bio-char that produced 23.23–36.4%, w/w (Table 3) from a household firewood for soil amelioration can store 0.27–0.95 t C year<sup>-1</sup> for over a century (Fig. 8).

**Table 4** The mean ash content of firewood, bio-oil, and bio-char of different tree species

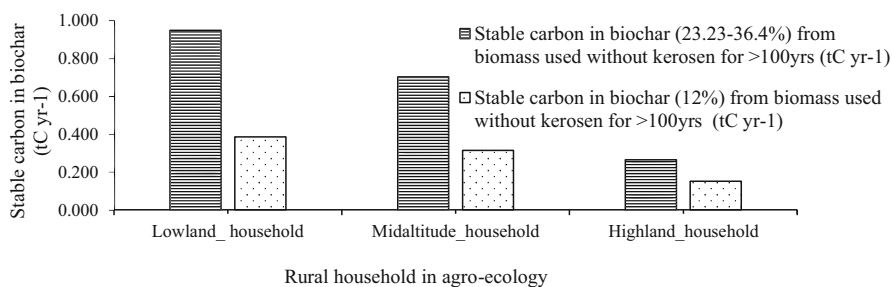
Species	Mean ash (% w/w)		
	Firewood	Bio-oil	Bio-char
<i>A. abyssinica</i>	4.586	0.531	15.03
<i>A. albida</i>	4.421	0.567	12.80
<i>A. decurrens</i>	1.418	0.688	3.72
<i>A. schimperi</i>	4.382	0.758	20.65
<i>A. seyal</i>	3.471	0.794	9.45
<i>C. collinum</i>	7.358	0.588	16.11
<i>C. edulis</i> <sup>a</sup>	7.816	0.787	14.51
<i>C. equisetifolia</i>	1.788	0.892	5.36
<i>C. lusitanica</i>	1.049	0.685	2.27
<i>C. megalocarpus</i> <sup>b</sup>	6.159	0.724	16.38
<i>D. angustifolia</i>	1.506	0.727	5.17
<i>E. camaldulensis</i>	0.434	0.618	3.15
<i>E. globulus</i>	3.594	0.352	4.54
<i>E. schimperi</i>	8.418	0.775	15.98
<i>G. robusta</i>	0.742	0.135	3.50
<i>P. juliflora</i>	1.748	0.831	3.87
<i>P. patula</i>	7.459	0.146	6.36

<sup>a</sup>Leaves

<sup>b</sup>Fruit pod



**Fig. 7** Emission and carbon storage of fuels at household level with similar gross heating value. (Note: Negative x-axis indicates the CO<sub>2</sub>e stored in bio-char; positive X-axis indicates the CO<sub>2</sub>e emission)



**Fig. 8** Stable carbon storage in bio-char in converting firewood to bio-oil

## Discussion

The use of pyrolysis technology to reduce the wastage of biomass and diversify products like biochar, bio-oil, and syngas increases adaptation and mitigation to climate change (Shackley et al. 2012). Greater bio-oil yield was obtained from locally preferred firewood species that also had less bio-char and less parent material ash (Tables 3 and 4). *E. globulus* was the highest bio-oil yielder (43%, w/w) and locally preferred for firewood (Table 3). This was confirmed by other studies, as the amount of bio-oil yield of pyrolysis of *E. globulus* and pine wood was 75 (% w/w) at 500 °C, at a rate of 1000 °C s<sup>-1</sup> and 1 s vapor residence time (Granada et al. 2013). Maximum bio-oil yield of about 70–80% on dry basis of woody biomass pyrolysis was obtained at 480–530 °C from previous other studies. The temperature limit of 600 °C used in the present study was in line with other studies for lignocellulosic

biomass (Amutio et al. 2012). The overall yield of bio-oil was similar with other studies of different species; however, different tree species could require different levels of temperature, rate of heat, and vapor residence time (Okoroigwe et al. 2015), which require further study for each species.

Bio-oil and bio-char production of woody biomass depends on the structural components, cellulose, hemicellulose, and lignin. According to Akhtar and Amin (2011), higher content of cellulose and hemicelluloses favors formation of bio-oil; and higher lignin content favors formation of bio-char. *E. globulus* that produced the highest bio-oil (Table 3) contained 50% (w/w) cellulose (Dmitry and Neto 2007), than *G. robusta*, 46.38% (w/w) (Madan and Roymoulik 1990). However, the cellulose content of *C. edulis* in Yishak (2014) was 59% but had low bio-oil amount (25.83%, w/w) in the present study and requires further study. The ash content of bio-oil of the woody biomasses was lower than other studies (Table 4), which could be because of the lower ash content of the parent firewood (Table 4). The highest bio-char obtained from leaf residue of *C. edulis* (Table 3) could be attributed to the highest extractive and lignin content, about 31.5% (Yishak 2014). *G. robusta* was a recently introduced species when compared with a century old *E. globulus* and *E. camaldulensis* in the study area. Most of the fuel characteristics of *G. robusta* bio-oil were comparable to *E. globulus*, and therefore, it can be used as firewood plantation tree species in the area.

The calorific value of the bio-oil in the present study was relatively higher than other studies (Oduor and Githiomi 2013) (Fig. 5), which might be because of centrifuging the bio-oil with distilled water and subsequent dehydration. Better calorific value was obtained from the bio-oil than the parent firewood. Depending on the level of technology, the same wood from a tree species can be used in three different forms of biomass fuels including firewood, bio-oil (bio-char), or charcoal. The processing from firewood to bio-oil diversifies income source. The production processes of bio-char and charcoal have similar pyrolysis technique with similar calorific value, about 28–30 MJ kg<sup>-1</sup> (Namaalwa et al. 2007). Therefore, in order to reduce the deforestation rate, conversion to bio-oil and bio-char increases the efficiency of biomass use and improves the adaptation to climate change.

In the bio-char, the amount of fixed carbon and volatile matter at moisture content 1.3–7.74 (% w/w) (Fig. 6) were comparable to other studies. Volatile matter of less than 20% and bio-char fixed carbon content over 50% from all of the 17 species (Fig. 6) obtained in the present study indicated the absence of labile carbon and their potential of long time carbon storage (Awad et al. 2012).

Since GHG emissions from bio-oil and firewood are taken up by the re-growing trees, there is no net emission except end use emission as indoor pollutant smoke. The end use emission as indoor pollution of bio-oil is lower than the firewood combustion because in bio-oil non-condensable gases are removed in manufacturing areas. Therefore, the use of bio-oil is safer than the direct use of firewood because of the reduction of smoke (Demirbas 2004).

The carbon storage in bio-char is a synergy to afforestation and to reduce climate change (Lehmann et al. 2006). The bio-oil and bio-char production technology could also use cheap sources of feedstock like organic wastes to reduce pressure on forests,

to dispose waste and retard emission. Moreover, the reduction in forest biomass utilization improves water resources availability, secures clean air to breathe, and generates income by selling the forest products so that climate change adaptation could be improved.

---

## Conclusion and Recommendation

The pyrolysis of woody biomasses of different tree species produced different quantity and quality of bio-oil and bio-char yield. Since the bio-oil and bio-char yield of *A. seyal*, *D. angustifolia*, *E. schimperi*, *E. globulus*, *C. equisetifolia*, and *G. robusta* was over 62% (w/w) of the parent firewood biomass used in pyrolysis, these can be selected for plantation development and climate change adaptation. Centrifuging pyrolysis oil with distilled water and subsequent dehydration resulted in increased calorific value to 33 MJ kg<sup>-1</sup> in *E. globulus*. The production and simultaneous use of bio-oil yield (21.1–42.87%, w/w) and bio-char yield (23.233–36.40%, w/w) for household cooking energy and for carbon storage, respectively, instead of firewood reduced end use emission by 71.48–118.06% in each household of lowland to highland PA of the studied area, which could increase adaptation to climate change by reducing the cost of indoor pollution. Therefore, pyrolysis of biomass generally reduces wood wastage, creates jobs, and provides organic carbon as adaptation to climate change. In order to reduce transport cost of low density and high volume biomass, and to reduce the number of transportation vehicles, it is important to establish small-scale biomass pyrolysis firm in electrified parts of Ethiopia that produce bio-oil and bio-char from woody and non-woody organic wastes to diversify income and to increase the adaptive capacity of the rural people to climate change. Moreover, carbon storage potential of bio-char can be used to improve soil fertility in rural areas as a means of climate change adaptation and mitigation. The tree/shrub species used for making charcoal in Ethiopia are mainly slow growing indigenous species existing in natural forest, and there should be a guiding policy to plant tree species like *A. seyal*, *D. angustifolia*, *E. schimperi*, *E. globulus*, *C. equisetifolia*, and *G. robusta* for charcoal making and to strengthen climate change adaptation.

**Acknowledgments** The research was financially supported by Hawassa University, Wondo Genet College of Forestry and Natural Resources, Central Ethiopia Environment and Forestry Research Center, and Association of African Universities Small Grant for Post Graduate Theses and Dissertations.

---

## References

- Akhtar J, Amin N (2011) A review on process conditions for optimum bio-oil yield in hydrothermal- liquefaction of biomass. *Renew Sust Energ Rev* 15:1615–1624
- Aliyu B, Agnew B, Douglas S (2010) *Croton megalocarpus* (Musine) seeds as a potential source of Bio-diesel. *Biomass Bioenergy* 34(10):1495–1499. <https://doi.org/10.1016/j.biombioe.2010.04.026>

- Amutio M, Lopez G, Artetxe M, Elordi G, Olazar M, Bilbao J (2012) Influence of temperature on biomass pyrolysis in a conical spouted bed reactor. *Resour Conserv Recycl* 59:23–31
- Arias BR, Pevida CG, Feroso JD, Plaza MG, Rubiera FG, Pis-Martinez JJ (2008) Influence of torrefaction on the grindability and reactivity of woody biomass. *Fuel Process Technol* 89 (2):169–175
- ASTM (American Society for Testing and Materials) (1989) Annual book of ASTM standards, petroleum products, lubricants and fossil fuels. Sect 5, v 5 Gaseous fuels, coal and coke. ASTM, West Conshohocken. PCN-01-050589-13
- Awad YM, Blagodatskaya E, Ok YS, Kuzyakov YY (2012) Effects of polyacrylamide, biopolymer, and biochar on decomposition of soil organic matter and plant residues as determined by <sup>14</sup>C and enzyme activities. *Eur J Soil Biol* 48:1–10
- Bekele TA (2007) In: Tengnäs B, Kelbesa E, Demissew S, Maundu P (eds) Useful trees and shrubs of Ethiopia: identification, propagation and management for 17 agroclimatic zones. RELMA in ICRAF Project World Agroforestry Centre, Nairobi, p 559
- Bird N, Cowie A, Cherubini F, Jungmeier G (2011) Using a life cycle assessment approach to estimate the net greenhouse gas emissions of bioenergy. IEA bioenergy P 20, [www.ieabioenergy.com](http://www.ieabioenergy.com). Accessed 17 Oct 2019
- Brown R (2009) Bio-char production technology. In: Lehmann J, Joseph S (eds) Bio-char for environmental management: science and technology. Earthscan, London, pp 127–146
- Chidumayo EN, Gumbo DJ (2013) The environmental impacts of charcoal production in tropical ecosystems of the world. A synthesis. *Energy Sustain Dev* 17:86–94
- Cordeiro LG (2011) Caracterização e viabilidade econômica de bagaço de malte oriundo de cervejarias para fins energéticos João pessoa, 120 f
- Demirbas A (2004) The influence of temperature on the yields of compounds existing in bio-oils obtained from biomass samples via pyrolysis. *Fuel Process Technol* 88:591–597
- Dmitry VE, Neto CP (2007) Recent advances in Eucalyptus wood chemistry: structural features through the prism of technological response. <https://www.researchgate.net/publication/237632161>. Accessed on 16 Nov 2017
- Elliot DC (2012) Biomass pyrolysis to liquid fuels in the US 2G 2020, Biofuel Seminar, Helsinki, Finland, August 30, 2012
- Eze JN, Ibrahim PA, Tihami SA, Alfa M (2020) Assessment of drought occurrences and its implications on agriculture in Niger State, Nigeria. *Discov Agric* 6(15):1–10
- FAO (Food and Agricultural Organization of the United Nations) (2017) The charcoal transition: greening the charcoal value chain to mitigate climate change and improve local livelihoods, by van Dam Rome J. FAO
- Forest Products Laboratory (2004) Fuel value calculator. USDA Forest Service, Forest Products Laboratory, Pellet Fuels Institute, Madison. Available at <http://www.fpl.fs.fed.us>. Accessed on 17 July 2017
- Garcia-Perez M (2008) The formation of polyaromatic and dioxins during pyrolysis: a review of the literature with description of biomass composition, fast pyrolysis technologies and thermochemical reactions. Washington State University. <http://www.pacificbiomass.org/documents/theformationofpolyaromathydrocarbonsanddioxinsduringpyrolysis.pdf>. Accessed on 17 July 2017
- Granada E, Míguez JL, Febrero L, Collazo J, Eguía P (2013) Development of an experimental technique for oil recovery during biomass pyrolysis. *Renew Energy* 60:179–184
- IPCC (Intergovernmental Panel on Climate Change) (2006) Guidelines for national greenhouse gas inventories, and Emission Factor Data Base (EFDB) version from November 2016, number of emission factors: 16877. Chapter 1, V 2: Energy, Tables 14, 25 & 29
- Jindo K, Mizumoto H, Sawada Y, Sanchez-Monedero MA, Sonoki T (2014) Physical and chemical characterization of biochars derived from different agricultural residues. *Biogeosciences* 11:6613–6621
- Kannan P, Arunachalam P, Prabukumar G, Govindaraj M (2013) Bio-char an alternate option for crop residues and solid waste disposal and climate change mitigation. *Afr J Agric Res* 8 (21):2403–2412. <https://doi.org/10.5897/AJAR12.2083>
- Krajnc N, Prisljan P, Jemec T, Triplat M (2014) Development of biomass trade and logistics centres for sustainable mobilisation of local wood biomass resources – Biomass Trade Centre II:

- publishable report Ljubljana: Gozdarski inštitut Slovenije, 2014 ilustr <http://proforbiomed.eu/sites/default/files/14%20-%20Environmental%20impact.pdf>. Accessed on 21 Dec 2016
- Lehmann J, Gaunt J, Rondon M (2006) Bio-char sequestration in terrestrial ecosystems: a review. *Mitig Adapt Strateg Glob Chang* 11:403–427
- Madan RN, Roymoulik SK (1990) Evaluation of *Grevillea robusta* as a raw material for the production of dissolving pulp and viscose rayon. *Indian J Fibre Text Res* 15:180–184
- Miftah F, Tsegaye B, Sisay F (2017) Impact of energy consumption on indoor pollution in rural wooden houses of Southern Ethiopia in times of climate change. *Glob J Curr Res* 4(3):14–26. ISSN: 2320-2920
- Namaalwa J, Sankhayan PL, Hofstad O (2007) A dynamic bio-economic model for analyzing deforestation and degradation: an application to woodlands in Uganda. *Forest Policy Econ* 9:479–495
- Oduor NM, Githiomi JK (2013) Fuel-wood energy properties of *Prosopis juliflora* and *Prosopis pallida* grown in Baringo District, Kenya. *Afr J Agric Res* 8(21):2476–2481. <https://doi.org/10.5897/AJAR08.221>. <http://www.academicjournals.org/AJAR>
- Okoroigwe EC, Zhenglong LI, Shantanu K et al (2015) Bio-oil yield potential of some tropical wody biomass. *J Energy South Afr* 26(2):33–41
- Roberts KG, Glory BA, Joseph S et al (2010) Life Cycle Assessment of bio-char systems: Estimating the energetic, economic and climate change potential. *Environ Sci Technol* 44:827–833
- Shackley S et al (2012) Biochar, tool for climate change mitigation and soil management. In: Meyers RA (ed) *Encyclopedia of sustainability science and technology*. Springer, New York
- Sheng C, Azevedo JLT (2005) Estimating the higher heating value of biomass fuels from basic analysis data. *Biomass Bioenergy* 28(5):499–507. <https://doi.org/10.1016/j.biombioe.2004.11.008>
- Shimelis B (2011) Generation, composition and characteristics of urban solid waste in a major Khat producing and marketing area in Eastern Ethiopia. *Int J Environ Prot* I(5):9–16. Retrieved from <http://www.ij-ep.org>
- Xiu S, Shahbazi A (2012) Bio-oil production and upgrading research: a review. *Renew Sust Energ Rev* 16:4406–4414. <https://doi.org/10.1016/j.rser.2012.04.028>
- Yishak AY (2014) Liquid fuel production through pyrolysis of Khat and plastic waste mixture. A Thesis Submitted in Partial Fulfillment of the Requirements for Master Degree in Chemical Engineering under Env Engi Addis Ababa Institute of Technology (AAiT), School of Chemical and Bio-Engineering

**Open Access** This chapter is licensed under the terms of the Creative Commons Attribution 4.0 International License (<http://creativecommons.org/licenses/by/4.0/>), which permits use, sharing, adaptation, distribution and reproduction in any medium or format, as long as you give appropriate credit to the original author(s) and the source, provide a link to the Creative Commons license and indicate if changes were made.

The images or other third party material in this chapter are included in the chapter's Creative Commons license, unless indicated otherwise in a credit line to the material. If material is not included in the chapter's Creative Commons license and your intended use is not permitted by statutory regulation or exceeds the permitted use, you will need to obtain permission directly from the copyright holder.







# “Conservation Agriculture,” Possible Climate Change Adaptation Option in Taita Hills, Kenya

# 65

Lilian Motaroki, Gilbert Ouma, and Dorcas Kalele

## Contents

Introduction .....	1332
Status of Sustainable Agriculture in Kenya .....	1334
The Concept of CA .....	1335
The Benefits of CA .....	1336
Overview of Climate Change Risks and Vulnerability in the Taita Hills .....	1338
Climatic Variability in the Taita Hills .....	1339
Crop Production Trends .....	1341
Coping and Adaptation Strategies Currently Employed by Farmers .....	1344
Conservation Agriculture to Enhance Adaptation in the Taita Hills .....	1345
Barriers to Effective Uptake of CA .....	1346
Lessons Learned, Limitations, and Recommendations for Future Research .....	1348
Conclusion .....	1348
References .....	1349

## Abstract

The vicious cycle of food insecurity in Kenya and Africa at large is partly attributed to the high reliance on rainfed agriculture, which makes production systems vulnerable to the adverse impacts of climate change and variability. Conservation agriculture (CA) has been disseminated as a climate-smart practice that operates on three main principles to realize the multiple benefits of making

This chapter was previously published non-open access with exclusive rights reserved by the Publisher. It has been changed retrospectively to open access under a CC BY 4.0 license and the copyright holder is “The Author(s)”. For further details, please see the license information at the end of the chapter.

L. Motaroki (✉)

International Centre of Insect Physiology and Ecology (ICIPE), Nairobi, Kenya

G. Ouma · D. Kalele

Institute for Climate Change and Adaptation (ICCA), University of Nairobi, Nairobi, Kenya

e-mail: [gouma@uonbi.ac.ke](mailto:gouma@uonbi.ac.ke)

© The Author(s) 2021

W. Leal Filho et al. (eds.), *African Handbook of Climate Change Adaptation*,  
[https://doi.org/10.1007/978-3-030-45106-6\\_184](https://doi.org/10.1007/978-3-030-45106-6_184)

1331

crop production systems more resilient to climate change impacts, enhancing food security, and providing environmental services, such as carbon sequestration. As a major source of livelihood in the Taita Hills, agriculture is constrained by climate change owing to its rainfed nature. The yield and environmental and economic benefits of CA make it a suitable alternative approach to sustainable agricultural intensification, which is fundamentally different from conventional approaches based on intensive tillage and often disrupts ecosystem functions. This chapter provides the rationale for enhancing the adoption of CA in the Taita Hills by evaluating the current challenges affecting crop production, the role of CA in addressing the challenges and its potential benefits, and the barriers that must be overcome in order to promote its wide-scale adoption. A number of constraints appear to hinder the wide-scale adoption of CA in the Taita Hills, including lack of awareness, tenure-related issues, and weak policy and institutional support. Addressing these constraints will help catalyze investments for upscaling CA in the Taita Hills, with potential for replication in other parts of the country.

---

**Keywords**

Food insecurity · climate change and variability · vulnerability · tillage · conservation agriculture

---

**Introduction**

Despite being the backbone of many sub-Saharan Africa (SSA) economies, agriculture remains predominantly (95%) rainfed and therefore vulnerable to the impacts of climate change and variability (Adhikari et al. 2015). The Fifth Assessment Report of the Intergovernmental Panel on Climate Change (IPCC) presented strong evidence that surface temperatures across Africa have increased by 0.5–2 °C over the past 100 years. The report further indicates that from 1950 onward, climate change has altered the magnitude and frequency of extreme weather events. The frequency of cold days, cold nights, and frost has decreased, whereas the frequency of hot days, hot nights, and heat waves has increased (IPCC 2014). In addition, the recently released IPCC Special Report on global warming of 1.5 °C emphasizes that there are significant negative impacts at 1.5 °C temperature increase above pre-industrial levels and highlights that the observed warming in 2017 already reached 1 °C above pre-industrial levels (IPCC 2018). Since global warming of 1.5 °C is associated with extreme weather events, it poses a high risk to unique and vulnerable systems in Africa, especially agriculture, which is highly sensitive to weather and climate variables, including temperature, precipitation, and extreme weather events, such as droughts, floods, and severe storms.

The high spatial and temporal variability of rainfall, high temperatures, extreme weather events such as droughts and floods, and degradation of the sector's natural resource base (land, water, etc.) affect the agricultural production and thus food

security. Even during seasons with favorable weather conditions, poor agronomic practices have been indicated to limit crop production. According to the Montpellier Report (2015), projections show an approximately 20% increase in hunger and malnutrition levels in SSA due to climate change-related impacts. Therefore, the biggest challenge for SSA remains, i.e., meeting the required food needs through sustainable intensification practices, considering the continued reliance on rainfed agriculture.

In Kenya, the key staple crops include maize, beans, and cruciferous vegetables. As an example, maize is consumed by over 90% of the total population as a staple crop (Ochieng' et al. 2017). However, crop production is primarily done by small-holder farmers who have limited resources for investing in sustainable production practices. Kiboi et al. (2019) noted that the maize productivity in Kenya is currently very low ( $1.0 \text{ ton ha}^{-1}$ ) relative to the attainable potential of  $6\text{--}8 \text{ ton ha}^{-1}$ . The huge gap in maize yield is primarily attributed to low soil fertility across the country's cropland resulting from poor management and nutrient mining without proper replenishment. Erratic patterns of rainfall and high frequency of droughts interacting with lack of investment in practices that conserve soil and water also contribute to low crop yields (Ochieng' et al. 2017). As the population continues to grow and climate change impacts aggravate, the situation in Kenya is likely to worsen over the coming years. The scaling up and out of practices that can support crop production even in periods of sporadic rainfall through soil water retention and increased organic matter can help break the vicious cycle.

Conservation agriculture (CA) has been disseminated as a climate-smart practice for intensifying crop production and increasing farmers' resilience to climate change (Sommer et al. 2018). The Special Report on Climate Change by the IPCC (2019) indicates that conservation agricultural practices have the potential to restore degraded land and enhance food security. However, the statistics provided by the Food and Agriculture Organization (FAO) show that the uptake of conservation agriculture in Kenya is still very low and far from the recommended 10% adoption rate, which is considered as the threshold level that can spur widespread adoption of the climate-smart agricultural technique in the country. Statistics further show that of the 5.8 million ha of arable land in Kenya, only 40,000 ha is under CA, 70% of which is by large-scale farmers (Mutuku et al. 2020).

The agriculture in Kenya is a major driver of the economy and the entire food systems. It is a major source of livelihood for the majority of Kenyan people in terms of food security, economic growth, employment creation, and foreign exchange earnings. As a major source of livelihood and well-being in the Taita Hills, agriculture remains highly sensitive and exposed to the impacts of climate change. This emphasizes the need to create an enabling environment to increase investments in sustainable agricultural practices that enhance farmers' buffer capacity while increasing productivity in the long term. The CA practice in particular has the potential to offset these impacts and make agricultural systems more resilient to a changing climate.

This chapter therefore provides the rationale for enhancing the adoption of CA in the Taita Hills by evaluating the current challenges affecting crop production, the

role of CA, and its potential benefits as well as the challenges and barriers that must be overcome in order to promote its wide-scale adoption. The findings of this chapter will enable policy makers to prioritize investments for scaling up the adoption of CA practice in the Taita Hills, with potential for replication in other parts of the country.

---

## Status of Sustainable Agriculture in Kenya

A number of practices have been promoted as sustainable practices to enhance the resilience of farming systems in Kenya. These include agroforestry, soil and water conservation techniques such as terracing and irrigation, integrated soil fertility management, crop diversification, and conservation agriculture, inter alia (Kurgat et al. 2018). Despite the potential that these farming practices present for smallholder farming households and the environment, their adoption remains generally low in Kenya. The low adoption of sustainable agricultural practices is mainly attributed to barriers, such as low awareness, inadequate technical know-how, limited access to extension services, small farm sizes, and lack of capital.

Considering the smallholder nature of farming systems in Kenya, high population growth, and fragmented land holdings, the adoption of sustainable intensification farming practices is the most viable option to increase agricultural productivity (i.e., crop yield per unit area) to meet the constantly increasing food needs (FAO 2011a). It is also important to make production systems more resilient to biotic and abiotic stresses, especially those triggered by climate change, by maintaining soils in a carbon-rich state. In addition, avoiding further degradation of agricultural land and ecosystem services and rehabilitating the already-degraded agricultural land are urgent.

To achieve this, a shift is required from the current conventional tillage (CT)-based production systems of agricultural intensification as they have negative impacts on crucial natural resources, such as soil and water (Dumansky et al. 2014). The degradation of land resources is often accompanied by a decline in crop yields, hence the need for an alternative approach to agricultural production that is both ecologically sustainable and profitable (Jat et al. 2014). Another challenge for agriculture today lies in its environmental footprint and contribution to climate change. According to the IPCC (2014), agriculture contributes approximately 30% of the total greenhouse gas (GHGs) emissions comprising CO<sub>2</sub>, N<sub>2</sub>O, and CH<sub>4</sub> and is also affected by the impacts of climate change.

The sustainable intensification of the agricultural production paradigm proposed by the FAO (2011a) emphasizes the need for agricultural practices that are productive and remunerative, which enhance both the resilience of the natural resource base and environment and provide environmental services, such as carbon sequestration. This implies that the sustainable intensification of crop production should not only reduce climate change impacts on crop production but also address the causes of climate change through GHG emission reduction. Moreover, sustainable intensification practices should enhance above- and belowground biodiversity within the

crop production systems to achieve better productivity. According to Jat et al. (2014), CA delivers on all of the aforementioned goals. The CA practice promotes the soil's biological activity, thus stabilizing the yields in the long term and increasing the soil's sequestration capacity.

## The Concept of CA

Conservation agriculture is described as an approach to managing agro-ecosystems for improved and sustained productivity, increased profits, and food security while preserving and enhancing the natural resource base and the environment (FAO 2014a). CA is founded on three main principles, namely:

- Minimum or no tillage: This entails the minimum soil disturbance during planting, weeding, or harvesting. In special cases, seeding may be done in strips or bands, taking care to disturb less than 25% of the soil surface (FAO 2014b).
- Maintaining permanent organic mulch on the soil comprising of crop residues or cover crops.
- Diversifying the species of crops grown through sequences, rotations, or where perennial crops are involved using a balanced mix of leguminous and non-leguminous crops.

Through the three overarching principles, CA aims to conserve, improve, and make more efficient use of natural resources through integrated management of available soil, water, and biological resources (Vanlauwe et al. 2014a). This enhances environmental conservation and sustained agricultural production. CA has also been shown to reduce crop vulnerability to extreme weather events. For instance, in drought conditions, it reduces crop water requirements by up to 30%, makes better use of soil water, and facilitates deeper rooting of crops. In extremely wet conditions, CA facilitates rainwater infiltration, reducing the risk of soil erosion and downstream flooding.

The minimum soil disturbance principle of CA emphasizes the need for direct seeding, and once the soil condition has been well developed, tillage should be eliminated altogether. Soil disturbance from cultural practices such as weeding should be as minimal as possible, and a permanent or semi-permanent organic soil cover should be maintained all year round. This can be in the form of intercrops, cover crops, or mulch acquired from the residues of the previous crop. In addition, the diversification of crop rotations, association, and sequences adapted to the local environmental conditions should be practiced regularly (Njeru 2016). These help in maintaining above- and belowground biodiversity, fixing nutrients such as nitrogen into the soil, building soil organic matter, and suppressing the buildup of pests. The crop rotation principle also enhances soil fertility when legumes are included. The sequencing of crops according to seasons in the crop rotation cycle further minimizes the buildup of insect pests and diseases while optimizing nutrient use between the different types of crops.

## The Benefits of CA

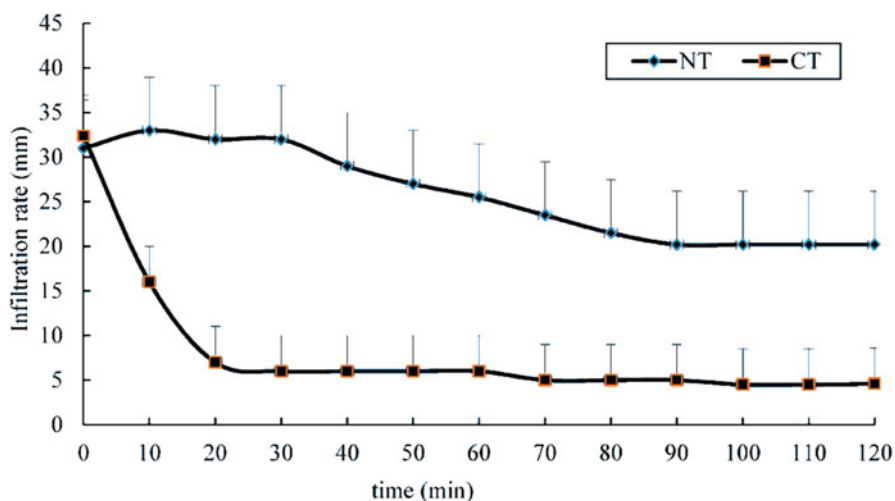
### Impacts on Soil Quality

Soil is considered to be of good quality when it can sustain biological productivity, maintain environmental quality, and promote plant and animal health. The positive impact of CA with respect to soil quality improvement is often exhibited by an increase in soil organic carbon, good infiltration rates, high water-holding capacity, and good soil structure (Naab et al. 2017; Bamutaze et al. 2019; Mgolozeli et al. 2020). For instance, in their study, Mgolozeli et al. (2020) demonstrated the effect of CA in improving soil organic carbon particularly in the top 10-cm soil depth, promoting higher soil aggregate stability and improving the overall condition of the soil. Comparative studies of the infiltration capacity of soils under no-tillage (NT) and CT systems showed that soils in the NT system had higher total infiltration, and in the final steady state, the NT plots had an infiltration rate that was four times that of the CT plots (Fig. 1).

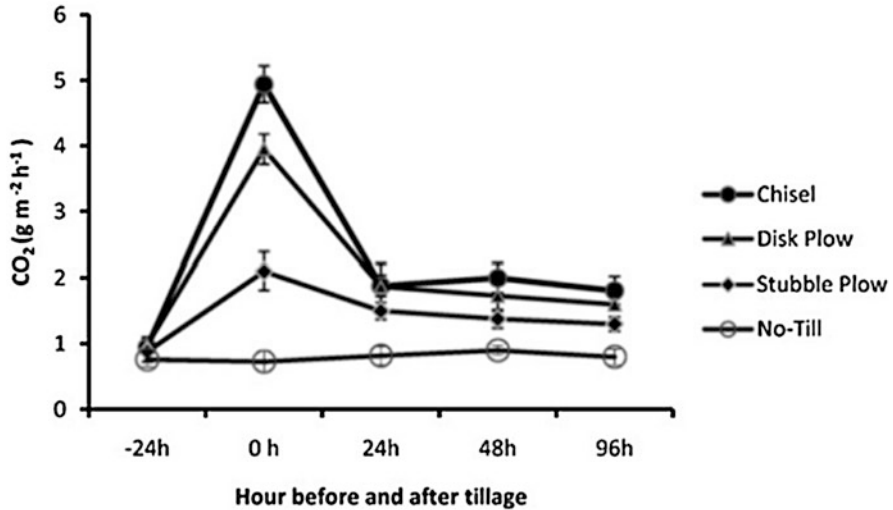
A conversion to conservation tillage from the conventional practices, in line with the CA principles, therefore helps improve soil structure and soil organic carbon, reduce the soil erosion risk, conserve soil moisture, reduce soil temperature fluctuations, improve soil quality, and the regulatory role it plays in the environment (Dube et al. 2012; Kakaire et al. 2015).

### Impacts on Soil Carbon

Conventional tillage practices, such as the disk and chisel plough, are often associated with the significant loss of soil carbon (Fig. 2). The intensive cultivation of agricultural land has been shown to result in low amounts of soil carbon, limiting not



**Fig. 1** Changes in the soil infiltration rate within 120 min under no-tillage (NT) and conventional tillage (CT) treatments. (Source: Mgolozeli et al. 2020)



**Fig. 2** CO<sub>2</sub> fluxes from soils associated with full tillage and NT systems. (Source: Mgozozeli et al. 2020)

just the soils' carbon sequestration capacity but also productive capacity (Dube et al. 2012). Under a changing climate, organic mulch has the potential to enhance soil productivity through the moderation of soil temperatures. For instance, combining mulching and NT can help combat climate change by enhancing carbon sequestration processes while minimizing CO<sub>2</sub> emissions into the atmosphere (Haddaway et al. 2016). Thus, aside from the increased productivity and soil and land restoration, CA realizes additional benefits of environmental sustainability.

### Economic Benefits

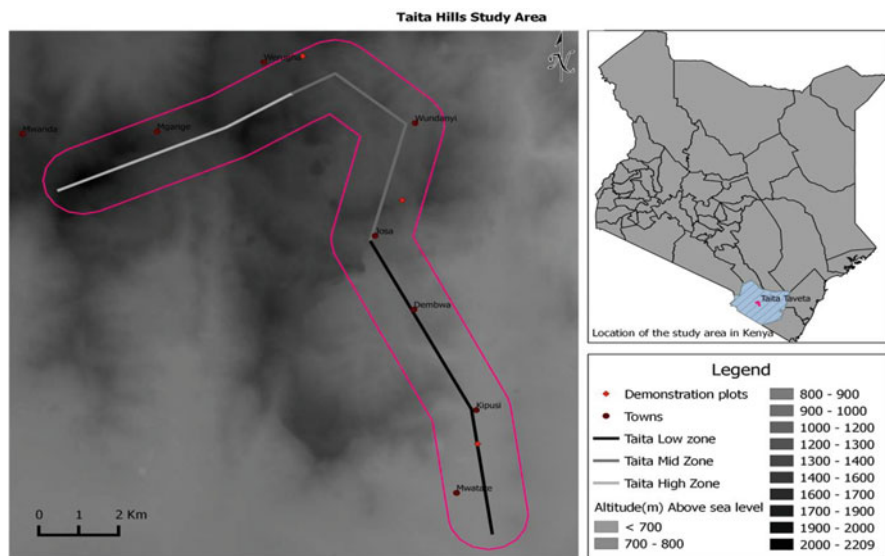
In addition to the potential of CA in sustaining crop production, the practice has also been established to realize economic benefits for farmers. The findings from a study by Micheni et al. (2015) showed that although the initial costs for CA establishments, especially with weeding, were high in the first two seasons, the net income from NT systems was significantly higher compared with that of CT practices in the long term. For instance, in the fourth season, the CA costs significantly decreased to USD 24/ha compared with the constant costs of conventional systems of USD 88/ha. High cost saving was realized from the elimination of land preparation and weeding, which are common agronomic practices in CT systems. These findings are comparable with those of Guto et al. (2012) and Naab et al. (2017) who indicated that the net income from CA was higher than that of conventional systems. The low labor requirements in the CA system imply that there will be more time available to engage in off-farm income-generating activities. Additional studies from Morocco show that for many smallholder farmers, the economic gain attained from a practice supersedes the gains made in soil conservation when it comes to the adoption of labor-saving technologies (Mrabet et al. 2012). The benefits accruing from NT practices are

therefore not just ecological/environmental but also reduced production costs and higher incomes to improve the well-being of farm families.

## Overview of Climate Change Risks and Vulnerability in the Taita Hills

The Taita Hills are located in the Taita–Taveta County within the coastal region that lies in South Eastern Kenya. The hills form the northernmost part of the 850-km<sup>2</sup> stretch of the Eastern Arc Mountains in Kenya and lie within the Tsavo ecosystem which is mainly semiarid. The hills extend through different altitudinal zones depicting different agro-ecological zones within the area (Fig. 3).

Climatic and non-climatic factors interact to make the Taita Hills vulnerable to the impacts of climate change. According to Waithaka et al. (2013), some of the visible changes associated with climate change and variability in the area include the degradation of soils from moisture stress and high temperatures, limited rainfall as observed in the reduction of the volume of water in rivers, and increased frequency of extreme weather events such as floods and droughts, among others. According to the GoK (2017), the Taita Hills experience two major rainfall seasons: the long-rains season experienced between March and May (MAM) and the short-rains season experienced between October and December (OND), which in turn give rise to two planting seasons. Farmers rely on both seasons for the cultivation of their staple crops. However, the short-rains season has been noted to be more reliable than the long-rains season (GoK 2017). This is because the long-rains season is characterized



**Fig. 3** Geographical location of the study area (Source: Motaroki 2016)



by, among other factors, unreliable rainfall patterns, whereby the onset of rain is delayed and cessation occurs very early in the season.

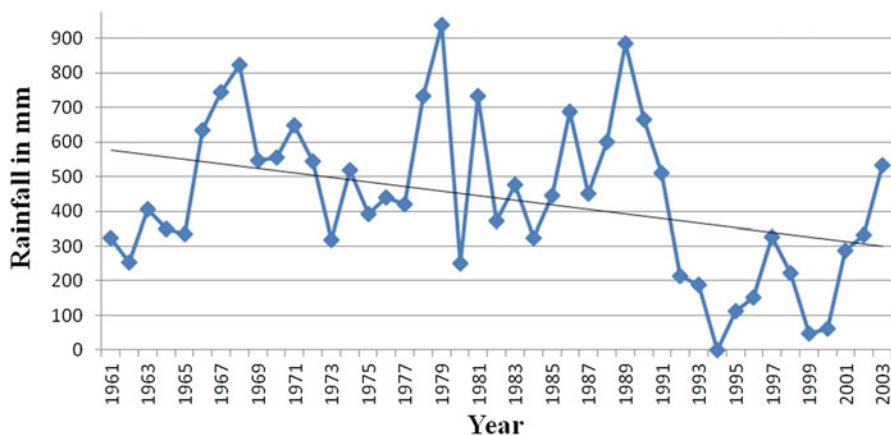
Non-climatic factors, such as high population growth, high poverty levels, poor farming methods, deforestation, and low use of technology, also have negative impacts on the status of agricultural resources, such as land and water. Due to the high rates of population growth, the area is currently characterized by small fragmented land holdings that are cultivated frequently with minimal conservation efforts, thus resulting in highly degraded soils with low fertility (Maeda 2012). A study by Muya et al. (2019) in the Taita Hills showed that in the maize-based and horticultural systems that are intensely cultivated, the amount of soil C was very low (1.6%) compared with soils under forests where the amount of C was about 7.6%. The land use intensity (LUI) in horticulture and maize-based systems was found to be over 30% compared with the LUI in forest systems (less than 2%). A similar trend was observed in the productivity index (PI), with the highest (40–50%) being recorded in natural forest and grassland and the lowest (15–20%) in horticultural and maize-based systems. The study concluded that the low soil quality and low productivity in horticulture and maize-based systems were associated with the intensification of land use as a result of inadequate knowledge on the appropriate management practices to apply. High poverty levels and lack of information cause people to engage in unsustainable practices, such as deforestation and poor farming methods, which result in land degradation. In the areas that have undergone deforestation, soil erosion has been indicated to be a major problem, with most of the terrain characterized by deep gullies.

## Climatic Variability in the Taita Hills

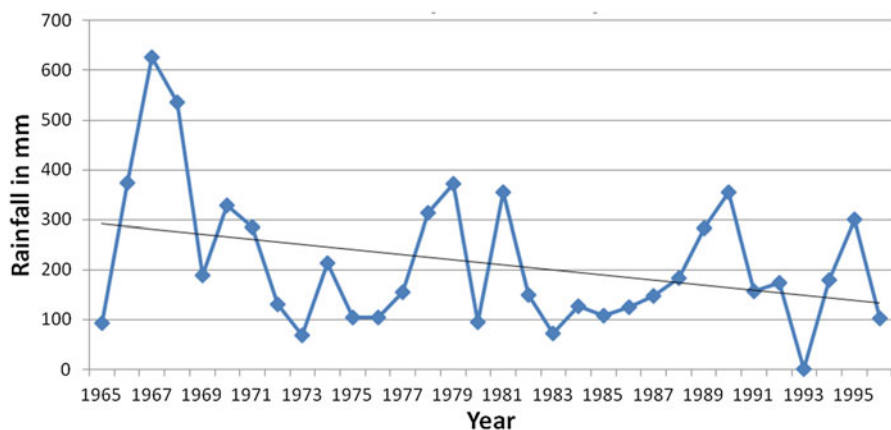
Analysis of rainfall data for the County showed an overall declining trend in the amount of rainfall received in the various agro-ecological zones since the 1960s. The time series plot for Wundanyi (mid-altitude agro-ecological zone) showed a decline in the amount of rainfall received, the average for the years between 1993 and 2006 being less than 600 mm. This is an area that initially received between 900 and 1200 mm of rainfall per season, thus indicating a large deficit in the mentioned years (Fig. 4).

The time series analysis of Maktau in the lower zone shows the highest amount of rainfall recorded to be 626.4 mm in 1967; otherwise, there is a general declining trend in the years following 1967, with most of them receiving less than 350 mm of rainfall. This is below the average precipitation range for the lowlands which lies between 350 and 400 mm. Furthermore, the optimum rainfall condition for productive agriculture in the lowland areas is 450 mm, considering the maize variety grown. However, the time series shows the amount of rainfall received to be less than 450 mm for the period when rainfall was recorded in the weather station at Maktau (Fig. 5).

The time series analysis for the short rainy season (OND) also shows a general declining trend of observed rainfall in all the three agro-ecological zones. In the high-altitude zone, the average annual rainfall received is below 700 mm for an area that received more than 1000 mm in the past years. Similar trends are observed in the



**Fig. 4** Time series plot of MAM rainfall season for Wundanyi-1480 m.a.s.l (Source: Motaroki 2016)



**Fig. 5** Time series plot of MAM rainfall season for Maktau-700 m.a.s.l (Source: Motaroki 2016).

mid- and low-altitude agro-ecological zones where the average annual rainfall remains below 600 mm and 400 mm, respectively.

This is in agreement with the farmers’ perception of variations in rainfall. The respondents from the focus group discussions (FGDs) conducted in each of the three agro-ecological zones noted that they were aware of the changes in rainfall that had taken place in the Taita Hills area over the past 20 years. The most obvious changes in rainfall reported by the respondents included drought and erratic rainfall patterns characterized by late onset and early cessation of seasonal rainfall. More specifically, drought was reported to be the most serious event, as it usually results in the loss of the entire crop, whereas erratic rainfall patterns resulted in a decline in crop yield and

food shortages. Similarly, studies on the Taita Hills by Mwalusepo et al. (2015) established that the farmers were aware of the climate variability and change within their localities and the perceived changes in rainfall regimes and temperatures as well as the implications on their livelihoods.

Drought has already been indicated as a threat to food security in Kenya and is reported by the GoK (2012) as an important cause of crop losses in the Taita Hills. Observations from the IPCC (2014) show that rainfall in East Africa is likely to increase in the twenty-first century, which will be indicated by an increase in the number of extreme wet days to roughly 20%. However, even if the amount of rainfall recorded in the preceding years increased, it may not translate to improved agricultural production because the projected increases in temperature will lead to high evapotranspiration rates, thus causing water scarcity. Farmers also noted significant temperature variation with the cycles for crops like maize getting shorter and bean farming particularly in the high altitude areas that were initially very cold becoming more favorable. The high temperatures have also been accompanied by an increase in the incidence of pests and diseases that causes the decline in productivity in both crops and livestock. According to the Food and Agriculture Organization, FAO (2016), the production techniques that are part of conservation agriculture, for example, crop rotations and maintenance of a permanent soil cover, enhance soil and water conservation, thus enabling crops to withstand periods associated with rainfall variability and drought.

## Crop Production Trends

The data from Osano *et al.* (2018) show that 80% of the total households in the Taita–Taveta County engage in maize production, 46% in bean crop production, and 31% in cowpea production. However, while the acreage under crop production has continuously increased, yields have continuously declined over the years due to climate change and other factors (Table 1). The overall productivity of major staple crops is very low, hence the need for better farming technologies and improved varieties. The maize crop in particular is highly sensitive to fluctuations in climate, with moisture and heat stress identified as the primary hazards for the crop.

**Table 1** Short-rains crop production in the Taita–Taveta County in 2017

Crop	Acreage (ha) planted in the short-rains season	Long term average (LTA) acreage planted in the short-rains season	Actual production (90 kg bags) in the short-rains seasons	LTA production (90 kg bags) in the short-rains season
Maize	9172	9600	7849	60965
Cowpeas	805	810	4035	6830
Green grams	1079	1289	5186	5930

Source: Osano *et al.* (2018)

**Table 2** Long-rains crop production in 2017

Crops	Acreage (ha) planted during the long-rains season	LTA (ha) (5 years) planted during the long-rains season	Actual long-rains production (90 kg bags)	Long-rains seasons LTA production (90 kg bags)
Maize	3681	7380	5522	22140
Beans	1069	1735	3207	10410
Green grams	1123	1566	4492	8613

Source: GoK (2017)

The land area under maize and cowpea cultivation during the 2017 short-rains season was near the long-term average (LTA), excluding the land area under green gram cultivation, which was 16% below the LTA (Osano et al. 2018). Despite the slight reduction in acreage under cultivation, the actual production of green grams was better than that of maize and beans. The 2017 short-rains seasons was also characterized by an 87% decline for maize production, 40% for bean production, and 13% for green gram production compared with the LTA (Table 1). The decline in maize production was attributed to late onset of the short rains, poor rainfall distribution both in time and in space, early cessation of rains, and crop damage caused by wildlife. Cowpea was affected by increased plucking of leaves by farmers for vegetable consumption, which negatively affected the yields and the crop's growth, hence reducing the production.

The County is mainly dependent on short rains for crop production, whereas the long rains that have increasingly become unreliable contribute 20% of the food requirements in the County. Table 2 shows the production of maize, beans, and green grams, which are the major crops grown during the long rains. The area under maize, bean, and green gram production declined by 50%, 38.4%, and 28.3%, respectively, due to prior weather forecasts, indicating the possibility of reduced rainfall during the long rains. Poor performance of the preceding short-rains seasons also contributed to the farmers' reluctance in cultivating large areas during the long-rains season (Muraguri and Nyamai 2017).

There was a significant decline in the production of all the three major crops: 75% for maize, 69.2% for beans, and 47.8% for green grams. Such a decline is mainly attributed to poor rainfall distribution in time and space as well as late onset and early cessation of rainfall. This is in agreement with the findings from a household survey targeting 600 households in the area where respondents noted that food shortages are currently on the rise, and farmers do not obtain enough yields as they did in the past. The main reasons reported for this were climatic events, including erratic rainfall patterns, above- and below-average rainfall, strong winds, floods, and frost. Other factors mentioned were high occurrence of pests, such as bean aphids, bean weevils, and cutworms, soil factors especially poor soil fertility, poor agronomic practices, and lack of inputs. The decline in crop production is a clear indication that farmers need to adopt CA which has shown potential to increase production through the integrated management of available soil, water, and biological resources

(FAO 2018). This reduces the vulnerability of crops to extreme weather events, such as droughts and floods, thus sustaining crop production.

### Soil-Related Constraints

Soils are the foundation for agricultural production, hence the need for their sustainable use and management. The fertility status of soil determines the level of crop yields achieved. According to the GoK (2014), soil degradation is a major challenge to agricultural production in the Taita Hills, which leads to a decline in soil fertility. Based on the results from the household survey (Table 3), 63.3% of the respondents considered their soils to be moderately fertile, 15% noted that it was poor, 18.7% reported their soils to be very fertile, whereas 3% did not know the fertility status of their soils. When asked whether there had been a change in the fertility of their soils considering the quantity of yields obtained over the last 10 years, 55.9% indicated that it had declined, 25.2% reported it remained the same, whereas 15.2% reported that it had improved. The key factors responsible for the decline in soil fertility include continuous ploughing reported by 22.9% of the respondents, drought reported by 13.5%, use of inputs mentioned by 13.7%, floods reported by 9%, and lack of inputs reported by 2.2%. Those whose soil fertility had improved attributed such an improvement to enhanced land use practices. However, a larger percentage (29.7%) did not know the reason for the decline in the fertility of their soils.

Although the use of farm inputs, such as improved seeds, fertilizers, pesticides, and herbicides, is essential to achieve optimum crop production, assessments at the county level show that such use is generally low in the County. The low rates of input

**Table 3** Soil fertility status in the Taita Hills

Soil Factors	High Zone	Mid Zone	Low Zone	Total
<b>Soil Fertility N = 401</b>				
Very Fertile	32	15	28	75
Moderate	89	76	89	254
Poor	20	24	16	60
Do not know	1	1	10	12
<b>Change in Soil Fertility N = 401</b>				
Improved	17	27	17	61
Same	37	19	45	101
Declined	86	69	69	224
No response	2	1	12	15
<b>Reasons for the Decline in Soil Fertility</b>				
Continuous tillage	38	28	26	92
Droughts	30	10	14	54
Use of inputs	12	40	5	57
Floods	5	11	22	38
Lack of inputs	5	3	1	9
Improved land use practices	13	7	12	32
Do not know	31	40	48	119

use is attributed to a number of reasons, including high input prices, limited access due to the distance to markets, and failure to access inputs at the right time (GoK 2014). From the survey, the various inputs used in producing maize (staple crop) include commercial fertilizer reported by 24.2% of the respondents, improved seed variety reported by 35.9%, manure reported by 30.7%, and pesticides reported by 4.5%. However, the inputs used in common bean production were minimal, including commercial fertilizer reported by only 2% of the respondents, improved seed reported by 6.2%, manure reported by 4.7%, and pesticides reported by 0.2% of the respondents. Farmers attribute their constant low yields to the use of poor-quality seed, lack of fertilizer, and manure amendments during planting.

### Coping and Adaptation Strategies Currently Employed by Farmers

Just like most households in SSA, households in the Taita Hills rely on a combination of informal risk-sharing arrangements to cope with the impacts of climate change and variability. These include, for example, taking cash loans from neighbors and relatives to buy food, relying on remittances, and sending children to live with relatives (Shuaibu et al. 2014). These coping mechanisms are not sufficient or sustainable to address the challenges, and they are even more limited for the poor, landless and unemployed individuals, women, children, and large-sized households who are more vulnerable (Shuaibu et al. 2014). The respondents reported various ways in which they are coping up with the climatic events impacting their households. In coping with drought events, most of the respondents (70.9%) reported that they bought food, 6.6% sought off-farm employment, 2.8% ate different types of food, 4.7% borrowed from friends and relatives, 2.8% relied on food aid from the government, and only 2.3% changed their farming practices. However, while coping strategies such as buying food may help them in the short term, it is important to find long-term sustainable solutions, such as a shift into sustainable farming practices or livelihood diversification to off-farm activities that generate income to buffer against climate shocks (Table 4).

**Table 4** Actions taken to cope with drought

Action (N=213)	High Zone	Mid Zone	Low Zone	Total
Did nothing	4	1	8	<b>13</b>
Assistance from friends/relatives	3	3	4	<b>10</b>
Relied on savings	5	2	1	<b>8</b>
Government food aid	2	3	1	<b>6</b>
Changed farming practice	0	2	3	<b>5</b>
Bought food	48	35	68	<b>151</b>
Sought off-farm employment	5	5	4	<b>14</b>
Ate different types of food	2	1	3	<b>6</b>

(Source: Motaroki 2016)

According to the MoALF (2016), the government of the Taita–Taveta County has supported and promoted adaptation strategies, such as drought-tolerant varieties of crops, rainwater-harvesting techniques, growing of trees, terracing, and other climate-smart agricultural practices. However, despite the critical role that CA plays in restoring degraded soils, stabilizing yields in the long term, and enhancing food security, few studies have attempted to assess its role in making smallholder farming systems more resilient to the impacts of climate change.

## Conservation Agriculture to Enhance Adaptation in the Taita Hills

Projections show that in the period 2021–2065, the temperature in the Taita–Taveta County will increase by 0.4 °C, with greater changes expected in the long-rains season (MAM) (MoALF 2016). During the same period, projections show a 0.8% increase in precipitation in the long-rains season and a 6% increase in the short-rains season (OND). However, high evapotranspiration rates resulting from high temperatures will lead to prolonged moisture stress. The number of consecutive days experiencing moisture stress is expected to increase from 70 to around 85–90 in the long-rains season but is projected to decrease from 80 consecutive days to approximately 30 in the short-rains season.

Conservation agriculture in the Taita Hills has the potential to restore soil fertility and sustain agricultural production by stabilizing yields even during periods of sporadic rainfall and increased moisture stress, which are expected to increase in the future, while achieving other co-benefits, such as soil erosion control and reduced labor demands. However, making substantial gains from CA requires understanding when and where the practice is most effective. According to Mutuku et al. (2020), smallholder farming systems have large variations in terms of soil properties and rainfall conditions, which in turn affect the impact of CA-based practices on crop yields. There are also differences in the physical, biological, and chemical conditions of soils at the field scale as well as variations in weather patterns over time and scale.

### Case Study of CA in the Taita Hills

Although few studies have tried to assess the potential of CA in the Taita Hills, the experimental assessments of CA in comparison with conventional farming practices undertaken by Motaroki (2016) established that the practice can help in increasing crop production, particularly in the semiarid lowlands.

#### Case Study 1

A participatory learning and action approach was used to set up demonstration plots in each of the three agro-ecological zones to compare yields from conventional tillage practices and CA for two consecutive seasons. There was no visible difference in the key yield indicators for the two seasons

(continued)

examined in both the high and mid-altitude agro-ecological zones. This could be explained by the fact that farmers in the high and mid-zones do not experience extreme conditions of drought as the lower zones. However, for the two seasons studied, there was a large visible difference in all the yield indicators for the CA treatment compared with the conventional tillage practices in the low-altitude agro-ecological zone. The zone lies in an arid and semiarid land area characterized by low rains for most parts of the year and poor soils. The effect of mulch in conserving soil moisture as well as the combined effect of organic and inorganic fertilizers could explain the immediate change in the observed yield for the area. As a matter of fact, in the second season, only the CA plot sustained crop growth, whereas the entire crop died when the conventional practices were used due to low and erratic rainfall.

Case study 1 emphasizes the importance of soil protection using mulch and the role that good agronomic practices play in minimizing the growth of weeds, promoting the growth of healthy plants, and consequently improving crop yields, especially in the drier lower zone. The conventionally grown farmers' practice plots are characterized by poor crop growth and exposure to surface runoff. Furthermore, the fact that only the CA treatment yielded results during the JJAS season further reinforces the importance of CA in arid and semiarid zones as well as the need to invest in drought-tolerant varieties of crops. Similarly, on-farm experimentation of CA by Micheni et al. (2015) showed that in drier environments, crop yield response to CA was immediate, whereas in the wetter (highland) zones, significant advantages in yield were observed from the third season onwards.

## **Barriers to Effective Uptake of CA**

According to Njeru (2016), the issue of land tenure is a major factor influencing the adoption of CA in Kenya and many countries in Africa. There is a very low possibility of farmers investing in land with unsecured access in the long term. Particularly, considering the small sizes of land holdings in the Taita Hills, farmers have a tendency to rent in more land for their crop production. Farmers have reservations about adopting soil conservation practices such as CA because chances are high that the owners will claim their land back as soon as the fertility increases and they notice increased yields. Moreover, when farmers rent in land, they are more interested in maximizing profits from their tenancy; hence, investments in conservation practices such as CA that realizes benefits in the long term are not their priority.

In the initial years, CA increases weeds on the farm and requires additional inputs, without necessarily increasing yields. It may take up to 4 years before farmers



can notice any differences in yields after adopting CA since the restoration of soil fertility takes time. In the field assessment of CA, Motaroki (2016) established that in the two seasons examined, minimal changes in yield were observed between the CA and CT plots, especially in the high and mid-altitude agro-ecological zones. As such, farmers renting a plot for less than 5 years are less likely to adopt CA as their primary concern is to increase production and profits in the short term rather than increase the quality of soils they will only use temporarily. This implies that in order to scale up and enhance widespread adoption of CA in the Taita Hills, assuring farmers of tenure security is critical.

Further, a transition from tillage-based systems to CA incurs significant costs, and for the resource-poor farmers in the Taita Hills, this may be a hindrance to their adoption of the practice. It is therefore important to provide financial support and enable the initial stages of CA adoption by giving farmers the necessary incentives in the form of subsidies. In their analysis, Kassam et al. (2014) noted that there have been cases in SSA where farmers reverted to their conventional farming practices once support for CA adoption was stopped. The above observations are in line with the results from the household surveys which showed that with regard to farmers' knowledge of the CA practice, 39.7% of the survey respondents stated that they were aware about the practice, having been introduced to it through seminar and by neighbors, agricultural extension officers, and the radio. However, only 3.7% of those who were aware about CA practiced it on their farms, stating several barriers, such as high risk and lack of economic returns (Table 5).

Cultural barriers have also been identified as one of the greatest challenges to CA adoption that has been reported in Kenya (Njeru 2016). For as long as they have been farmers, Kenyans and Africans at large have always tilled their lands such that the introduction of zero or minimum tillage faces resistance and skepticism. Another important challenge arises from the slash-and-burn system that is common in many parts of the country and Africa at large, which diminishes the availability of crop residues for mulching and incorporation into the soil (Kassam et al. 2014). Furthermore, studies show that many farmers are reluctant to use herbicides in their farms, making weed management a challenge and a hindrance to optimum crop production. Giving these farmers support in understanding new concepts and principles will create the desired change in the mindset and promote commitment to a long-term process of changing their production systems and testing and adapting new practices and technologies.

**Table 5** Barriers to CA Uptake

Barrier s (N= 105)	High Zone	Mid Zone	Low Zone	Total
Small farm size	5	2	2	<b>9</b>
Expensive	1	3	4	<b>8</b>
Not profitable	29	5	10	<b>44</b>
Risk-prone	1	7	8	<b>16</b>
No specific reason	10	4	13	<b>27</b>

Studies by Pretty et al. (2011) have shown social capital to be an important prerequisite for a wide-scale adoption of sustainable practices. Farmers often have a tendency to trust their peers more than their formal advisors when evaluating potential innovations for their farms. This in effect emphasizes the importance and role of farmer organizations in embracing CA and drawing in more members within the locality to adopt the practice. Furthermore, scaling up CA to achieve impact at the local, sub-national, and national level will require a strong enabling policy and institutional environment characterized by training and enhanced access to knowledge, research, and the required inputs. If properly organized, the farmer groups or organizations can use their bargaining power to pressure local governments and institutions to create the required reforms to upscale CA (Kassam et al. 2014).

---

## **Lessons Learned, Limitations, and Recommendations for Future Research**

Conservation agriculture has been shown to stabilize yields in the long term and increase the soil's ability to sequester carbon, thereby delivering on both adaptation and mitigation goals. However, a number of barriers still hinder its effective upscaling to promote widespread adoption in the Taita Hills. Overcoming these barriers will require implementing a number of measures, including incentivizing resource-poor farmers in terms of tenure security and subsidies, enhancing farmers' understanding on the benefits of CA activities such as minimum tillage, creating an enabling environment through institutional and policy support, and leveraging on social capital in target localities to promote the adoption of CA, *inter alia*. The case study that informed this chapter was only conducted for two seasons, which hindered the evaluation of the significant differences between the treatments used. As such, future research will need to explore the possibility of conducting field assessments over several seasons and where possible replicate the treatments in order to assess whether significant differences in the actual yield exist between CA and conventional farming methods.

---

## **Conclusion**

Studies conducted in the Taita Hills have established that climate change and variability are occurring in the area as characterized by erratic rainfall patterns, high temperatures, and increased frequency of extreme weather events, such as droughts and floods. This poses a major threat to farming, which is the major source of livelihood in the area, considering that it is mostly rainfed and thus under the direct impacts of climate variability and change. Although CA has been established to maintain the soil in a carbon-rich condition and sustain production under a changing climate, its adoption remains slow due to existing barriers. To overcome these barriers and catalyze investments for upscaling and bringing about the desired reforms to advance the CA cause, strategies (policy, technological, and institutional)

must be put in place for an effective adoption. These include assuring farmers of tenure security, providing financial and technical support through appropriate subsidies, capacity development, and gender-responsive policies, inter alia.

---

## References

- Adhikari U, Poyan N, Sean W (2015) Climate change and eastern Africa: A review of impacts on major crops. *Food Energy Secur* 4(2):110–132
- Agriculture for Impact (2015) *The Farms of Change: African Smallholders Responding to an Uncertain Climate Future*. A Montpellier Panel Report.
- Bamutaze Y, Kyamanywa S, Singh BR, Nabanoga KGN, Lal R (2019) *Agriculture and ecosystem resilience in Sub Saharan Africa: livelihood pathways under changing climate*. Springer, Cham
- Dube E, Chiduzza C, Muchaonyerwa P (2012) Conservation agriculture effects on soil organic matter on a Haplic Cambisol after four years of maize–oat and maize–grazing vetch rotations in South Africa. *Soil & Tillage Research* 123:21–28
- Dumansky J, Reicosky DC, Peiretti RA (2014) Pioneers in soil conservation and Conservation Agriculture. Special issue, *International Soil and Water Conservation Research* 2(1)
- FAO (2011a) *State of land and water*. Rome: FAO
- FAO (2011b) *Save and grow: a policymaker's guide to the sustainable intensification of smallholder crop production*. Rome: FAO
- FAO (2014a) What is Conservation Agriculture? FAO CA website <http://www.fao.org/ag/ca/1a.html>
- FAO (2014b) CA Adoption Worldwide, FAO-CA website <http://www.fao.org/ag/ca/6c.html>
- FAO (2016) Increased productivity and profitability of smallholder farmers through promotion and up-scaling of GAP & CA in productive semi-arid areas of Kenya (IPP-GAP). Rome. Available at [http://www.fao.org/fileadmin/user\\_upload/FAO-countries/Kenya/docs/CA\\_Flyer.pdf](http://www.fao.org/fileadmin/user_upload/FAO-countries/Kenya/docs/CA_Flyer.pdf)
- FAO (2018) Conservation Agriculture in Kenya: beating drought and poor harvest. Available at <http://www.fao.org/fao-stories/article/en/c/1100298/>
- GoK (2012) *Taita-Taveta District Development Plan*. Government Printer.
- GoK (2014) *October to December 2013 short rains season assessment report*. Kenya Food Security Steering Group, Nairobi, Kenya
- GoK (2017) *Taita Taveta County: 2017 Long Rains Food Security Assessment Report*. National Drought Management Authority (NDMA), Kenya
- Guto SN, Pypers P, Vanlauwe B, de Ridder N, Giller KE (2012) Socio-Ecological Niches for Minimum Tillage and Crop-Residue Retention in Continuous Maize Cropping Systems in Smallholder Farms of Central Kenya. *Agronomy Journal* 104(1):188–198
- Haddaway NR, Hedlund K, Jackson LE et al (2016) How does tillage intensity affect soil organic carbon? A systematic review protocol. *Environ Evid* 5:1. <https://doi.org/10.1186/s13750-016-0052-0>
- IPCC (2014) Summary for policymakers. In: Field CB, Barros VR, Dokken DJ, Mach KJ, Mastrandrea MD, Bilir TE, Chatterjee M, Ebi YL, Estrada YO, Genova RC, Girma B, Kissel ES, Levy AN, MacCracken S, Mastrandrea PR, White LL (eds) *Climate change 2014: impacts, adaptation, and vulnerability*. Part A: global and sectoral aspects. Contribution of working group ii to the fifth assessment report of the Intergovernmental Panel on Climate Change. Cambridge University Press, Cambridge, UK/New York, pp 1–32
- IPCC (2018) *Global warming of 1.5°C. An IPCC Special Report on the impacts of global warming of 1.5°C above pre-industrial levels and related global greenhouse gas emission pathways, in the context of strengthening the global response to the threat of climate change, sustainable development, and efforts to eradicate poverty*. In: Masson-Delmotte V, Zhai P, Pörtner HO, Roberts D, Skea J, Shukla PR, Pirani A, Moufouma-Okia W, Péan C, Pidcock R, Connors S,

- Matthews JBR, Chen Y, Zhou X, Gomis MI, Lonnoy E, Maycock T, Tignor M, Waterfield T (eds). In press.
- IPCC (2019) Climate change and land: an IPCC special report on climate change, desertification, land degradation, sustainable land management, food security, and greenhouse gas fluxes in terrestrial ecosystems. In: Shukla PR, Skea J, Calvo Buendia E, Masson-Delmotte V, Pörtner H-O, Roberts DC, Zhai P, Slade R, Connors S, van Diemen R, Ferrat M, Haughey E, Luz S, Neogi S, Pathak M, Petzold J, Portugal Pereira J, Vyas P, Huntley E, Kissick K, Belkacemi M, Malley K (eds). In press.
- Jat RA, Sahrawat KL, Kassam AH, Friedrich T (2014) Conservation agriculture for sustainable and resilient agriculture: global status, prospects and challenges. In: Jat R.A, Sahrawat K.L, Kassam A. H, eds. Conservation agriculture: global prospects and challenges. Wallingford, UK: CABI, 1–25
- Kakaire J, Makokha GL, Mwanjalolo M, Mensah AK, Menya E (2015) Effects of mulching on soil hydro-physical properties in Kibaale sub-catchment, South Central Uganda. *Appl Ecol Environ Sci* 3:127–135
- Kassam A, Friedrich T, Shaxson F, Bartz H, Mello I, Kienzle J, Pretty J (2014) The spread of conservation agriculture: policy and institutional support for adoption and uptake. *Field Actions Sci Rep* 7:1–13
- Kiboi MN, Ngetich KF, Fliessbach A, Muriuki A, Mugendi DN (2019) Soil fertility inputs and tillage influence on maize crop performance and soil water content in the Central Highlands of Kenya Agric. *Water Manage* 217:316–331
- Kurgat BK, Ngenoh E, Bett HK, Stober S, Mwonga S, Lotze-Campen H, Rosenstock T (2018) Drivers of sustainable intensification in Kenyan rural and peri-urban vegetable production. *Int J Agric Sustain* 16(4–5):385–398
- Maeda EE (2012) The future of environmental sustainability in the Taita Hills, Kenya: assessing potential impacts of agricultural expansion and climate change. *Fennia* 190(1):41–59
- Mgolozeli S, Nciizah AD, Wakindiki II, Mudau FN (2020) Innovative pro-smallholder farmers' permanent mulch for better soil quality and food security under conservation agriculture. *Agronomy* 10(4):605
- Micheni AN, Kanampiu F, Kitonyo O, Mburu DM (2015) On-farm experimentation on conservation agriculture in maize-legume based cropping systems in Kenya: water use efficiency and economic impacts. *Exp Agric* 52(1):1–18
- MoALF (2016) Climate risk profile for Taita Taveta. Kenya county climate risk profile series. The Kenya Ministry of Agriculture, Livestock and Fisheries (MoALF), Nairobi
- Motaroki L (2016) Assessment of conservation agriculture as an adaptation option to climate change in the Taita Hills, Kenya. University of Nairobi
- Mrabet R, Moussadek R, Fadlaoui A, Van Ranst E (2012) Conservation agriculture in dry areas of Morocco. *Field Crops Res* 132:84–94
- Muraguri P, Nyamai D (2017) Taita taveta County 2017: long rains food security assessment report. National Drought Management Authority, Nairobi, Kenya
- Mutuku E, Roobroeck D, Vanlauwe B, Boeckx P, Cornelis M (2020) Maize production under combined conservation agriculture and integrated soil fertility management in the sub-humid and semi-arid regions of Kenya. *Field Crops Research*, p 254. Elsevier.
- Muya EM, Karanja N, Okoth PF, Roimen H, Mung'atu J (2019) Comparative description of land use and characteristics of belowground biodiversity benchmark sites in Kenya. UoN Digital Repository, Kenya.
- Mwalusepo S, Massawe ES, Affognon H, Okuku GO, Kingori S et al (2015) Smallholder farmers' perspectives on climatic variability and adaptation strategies in East Africa: the case of Mount Kilimanjaro in Tanzania, Taita and Machakos Hills in Kenya. *J Earth Sci Clim Change* 6:313. <https://doi.org/10.4172/2157-7617.1000313>
- Naab JB, Mahama GY, Yahaya I, Prasad P (2017) Conservation agriculture improves soil quality, crop yield, and incomes of smallholder farmers in North Western Ghana. *Front Plant Sci* 8:996. <https://doi.org/10.3389/fpls.2017.00996>
- Njeru EK (2016) Factors influencing adoption of conservation agriculture by smallholder farmers in Kenya a case of Laikipia East Sub-county Kenya. University of Nairobi, Kenya

- Ochieng J, Kirimi L, Makau J (2017) Adapting to climate variability and change in rural Kenya: farmer perceptions, strategies and climate trends *Nat. Resour. Forum* 41:195–208
- Osano K, Obondo V, Kertich J (2018) Taita Taveta County 2017: short rains food security assessment report. National Drought Management Authority, Kenya
- Pretty J, Toulmin C, Williams S (2011) Sustainable intensification in African agriculture. *Internat Journ of Agric Sustain* 9(1):5–24
- Sommer R, Paul BK, Mukalama J, Kihara J (2018) Reducing losses but failing to sequester carbon in soils – the case of Conservation Agriculture and Integrated Soil Fertility Management in the humid tropical agro-ecosystem of Western Kenya *Agric. Ecosyst. Environ* 254:82–91
- Vanlauwe B, Wendt J, Giller KE, Corbeels M, Gerard B, Nolte C (2014a) A fourth principle is required to define Conservation Agriculture in sub-Saharan Africa: the appropriate use of fertilizer to enhance crop productivity. *Field Crop Res* 155:10–13
- Waithaka M, Nelson GC, Thomas ST, Miriam K (2013) East African and Climate change: A comprehensive Analysis. International Food Policy Research Institute, Washington, DC

**Open Access** This chapter is licensed under the terms of the Creative Commons Attribution 4.0 International License (<http://creativecommons.org/licenses/by/4.0/>), which permits use, sharing, adaptation, distribution and reproduction in any medium or format, as long as you give appropriate credit to the original author(s) and the source, provide a link to the Creative Commons license and indicate if changes were made.

The images or other third party material in this chapter are included in the chapter's Creative Commons license, unless indicated otherwise in a credit line to the material. If material is not included in the chapter's Creative Commons license and your intended use is not permitted by statutory regulation or exceeds the permitted use, you will need to obtain permission directly from the copyright holder.





# Do-It-Yourself Flood Risk Adaptation Strategies in the Neighborhoods of Kano City, Nigeria

# 66

Aliyu Barau and Aliyu Sani Wada

## Contents

Introduction .....	1354
An Overview of Conceptualization of Flood Risk Adaptation .....	1356
Observing the Nature of Flood Risk Situation in Kano City .....	1357
Relief and Geology .....	1358
Climate and Hydrology .....	1359
Research Data .....	1359
Digital Elevation Model (DEM) of the Study Area .....	1362
Socioeconomic Characteristics of the Residents .....	1363
Socioeconomic Characteristics of the Respondent in the Study Area .....	1363
Public Perception and Current State of Flood Risk and Adaptation .....	1366
Public and Institutional Adaptation Response to Floods in the Study Area .....	1369
Flood Adaptation Strategies at Community Level .....	1372
Post-flood Community Response on Adaptation Strategies .....	1372
Institutional Flood Adaptation Response Strategies in the Study Area .....	1375
Conclusion .....	1377
References .....	1378

## Abstract

The urban poor in developing countries is hit hardest by climate-related extreme events such as flooding. Also, informal settlements lacking municipal support and immediate public response to flooding incur losses and thus exacerbate their sufferings. Left out or left alone, the vulnerable people from some parts of the ancient city of Kano develop their own efforts to protect themselves against the recurrent flood events. Hence, this chapter examines the nature of community-driven do-it-yourself (DIY) adaptation. The data was collected through field-based surveys, interviews, and questionnaires to enable in-depth analysis of the problem from socioecological point of view. The results identified flood drivers to include

A. Barau (✉) · A. S. Wada

Department of Urban and Regional Planning, Bayero University Kano, Kano, Nigeria

e-mail: [asbarau.urp@buk.edu.ng](mailto:asbarau.urp@buk.edu.ng); [saniwada2@gmail.com](mailto:saniwada2@gmail.com)

© The Author(s) 2021

W. Leal Filho et al. (eds.), *African Handbook of Climate Change Adaptation*,

[https://doi.org/10.1007/978-3-030-45106-6\\_190](https://doi.org/10.1007/978-3-030-45106-6_190)

1353

the nature of surface topography, torrential rainfalls, lapses, and inadequacies in the availability of drainage infrastructure and human behavioral lapses in drainage management. On the other hand, the DIY adaptation manifests in the use of sandbags, de-siltation of drainage, construction of fences, and drainage diversions. It is important to highlight that DIY adaptation is a good strategy; however, municipal authorities must come to the aid of such communities and revisit the absence of urban planning by supporting them through capacity building to find more effective solutions to the challenges of the changing climate and environment.

---

**Keywords**

Planning · Households · Climate Change · Vulnerability · Informal

---

**Introduction**

Climate-related disasters continue to spread and affect the poorer populations in both urban and rural areas. It has been suggested that flooding is the most widespread climate extreme event that accounts for more than 40% of disasters globally (Nkwunonwo et al. 2016). It is also considered as the third most damaging disaster after storms and earthquakes (Wilby and Keenan 2012). It was estimated that the average annual number of people affected by floods is likely to increase from one million in the 1990s to 25 million by 2050 (Salami et al. 2016). Nevertheless, the increased awareness and concerns over climate change have reinforced the need for adjustments on how human use land and other resources in order to limit risks and vulnerabilities that originate from global climate change (Verburg et al. 2012). Besides climate change, many studies have attributed the exacerbation of flooding to the nature of population density and standard of living especially in the lived environments of developing countries (Devkota et al. 2014). In other words, this implies that built environments in developing countries are most exposed to flooding and hence more response actions are needed from within and outside the lived environment. Efforts from within involve action by individuals and municipalities, and action from outside may involve states and federal actions to strengthen resilience to flooding and climate change. Importantly, it is critical to also put in place modalities for communicating climate knowledge to public in order to enable proper response to climate crisis (Barau and Tanko 2018).

Researchers from developing and developed countries consider flood adaptation from different approaches. For instance, Alfieri et al. (2016) focused on adaptation measures for flood risk reduction by putting emphasis on adaptive measures such as relocation, reduction of vulnerability, reduction of peak flows, and increased flood protection levels. On the other hand, Barau (2008) focused on adaptation measures oriented toward institutional perception but fails to assess public adaptation strategies deployed to prevent flooding. Some authors suggested that relief materials including healthcare services supplied to flood victims in Nigeria were inefficient

and paid too little attention given to efforts to reduce the future flood menace (Soneye 2014; Olanrewaju et al. 2019). Contrastingly, since the 1990s, the United States introduced the Community Rating System (CRS), a community-driven program that incentivizes local actions for addressing flood risk (Noonan and Sadiq 2018). It is apparent that climate change adaptation is not an exclusive business of the state or formal planning processes, but it goes down to efforts of communities and businesses to protect themselves (Colenbrander and Barau 2019; Udelsmann Rodrigues 2019). By implication, climate adaptation has become a concern of every stakeholder given the weakening resilience of urban areas in developing countries. Nevertheless, designing neighborhood or community resilience to flooding will benefit from understanding the social and ecological attributes of societies which are not limited to biophysical changes, infrastructure, mitigation planning, and public perceptions of extreme events (Parsons 2019). The potentials of grassroots action to address flooding in African countries are said to be a promising and effective self-defense mechanism in poorly serviced areas (Udelsmann Rodrigues 2019).

Flooding in Nigeria is the most common and recurring disaster with unprecedented damages caused by heavy rainfall and surface runoff which in 2012 in particular contributed to submergence of settlements along the Kainji, Jebba, and Shiroro dams in Niger State, the Lagdo dam in Cameroun located along the River Benue, the Kiri Dam on the River Gongola, and numerous additional irrigation dams (PDNA 2013). Consequently, this triggered the displacement of thousands of people and loss of lives and properties. According to the National Emergency Management Agency (NEMA), 363 people were killed, 5,851 injured, 3,891,314 affected, and 3,871,53 displaced due to the resulting floods. Similarly, it has been observed that flood disaster happens to be more frequent in Kano, Niger, Adamawa, Oyo, and Jigawa states possibly due to influence of river Benue, Niger and Ogun (Nkwunonwo et al. 2016).

Since the 1960s, the rainfall received in Kano region has exhibited notable fluctuations, however with increased flood incidents due to encroachment on environmentally sensitive areas such as floodplains along the ancient city walls which were traditionally reserved specifically for urban gardening (Barau et al. 2015). Studies revealed that between 2003 and 2007, Kano has experienced severe urban flood that claimed many lives and property – roughly 16,730 households were affected, 14 people were reported dead – and many were displaced (Barau 2008). In addition, flood water contaminates and pollutes the environment with garbage; many factors are responsible for the recurrent flood events with prolong rainfall leading to large volume of water with tendency of overwhelming the infiltration capacity of the soil. This often yield to large surface runoff beyond the carrying capacity of the already narrowed drainages filled with garbage and simultaneously adjoined with poor maintenance which end up polluting the environment (Azua et al. 2019). It is apparent that damages to lives and property has become a cyclic phenomenon in Kano metropolis. It was also reported that 18,397, 29,151, and 177 people in 2003, 2004, 2005, 2006, and 2007, respectively, were affected in the Dala Local Government Area, due to impact of flood (Barau 2008). The aim of this chapter is to assess



flood risk and adaptation measures in Dala Local Government Area in Kano city, Nigeria, and this is with a view to improving adaptation strategies in the area by identifying suitable and sustainable planning recommendations.

---

## **An Overview of Conceptualization of Flood Risk Adaptation**

Floods can occur within a matter of minutes, and its effects can be local, impacting a neighborhood or a community; it can even go beyond a single community to affect the entire river basins and multiple areas (Wilby and Keenan 2012). Flood risk and flood-related losses may increase due to human activity or decrease through an appropriate flood management, planning, and adaptation strategies (Kubal et al. 2009). Human interventions in the natural processes such as increase in settlement areas, removal of biotic habitats, population growth, and economic assets over low-lying plains make them more prone to flooding especially when alterations of natural drainage and river basin patterns and deforestation are on the rise (Muo 2015). This situation is typical of what obtains from urban areas of developing countries including Nigeria which has the largest population in Africa. Hence, flooding and its impact on population is a socioecological challenge as it has links and feedbacks between human and natural systems. The socioecological system approach is said to be important in private flood hazard adaptation strategies (Fuchs et al. 2017).

Cirella and Iyalomhe (2019) categorized flooding on the basis of spatiality which includes coastal flooding and river flooding, while Dhiman et al. (2019) added urban and areal flooding to the list. In a situation whereby towns and cities are located on these types of landscapes and in the case where the most vulnerable populations are located on such marginal lands, the struggle with risks of sea-level rise becomes even more complicated. Another factor is the accumulation of rainwater in low-lying areas with a high water table, or inadequate storm drainage (Cirella and Iyalomhe 2019). In addition to this, the main causes of flooding as posited by same author are not limited to heavy rainfall, blockage of waterways, building on flood plains, and poor land use planning. According to Dhiman (2019), urbanization was the most important driver of flood risk in the cities where inadequate drainage system in combination with ineffective spatial planning increases the flood risk. Additional damages from the floods are also included in the framework where simulation using climate model and further downscaling indicate high potential sensitivity of flood risk to climate change.

Flooding with its numerous and varied impact causes mortalities, population displacement, and property damage which may also critically endanger sustainable development pathways (Vojtek and Vojteková 2016). The literature on flood health impact rarely quantifies or classifies the causes and circumstances of deaths which in many instances are also determined by the prevailing socioeconomic and health conditions of the affected communities (Jongman 2018). Flood impacts range from socioeconomic, psychological, cultural, to environmental impacts (Alferi et al. 2016). The economic impacts include damage to public buildings, public utility

works, housing and household assets, losses in industry, and business trade. Other losses are those affecting petty shopkeepers, low-income earners, loss of revenue, and interruption of road and railway transportation. Flooding also triggers the outbreak of infectious diseases, e.g., fever, pneumonic plagues, dysentery, and common cold among others.

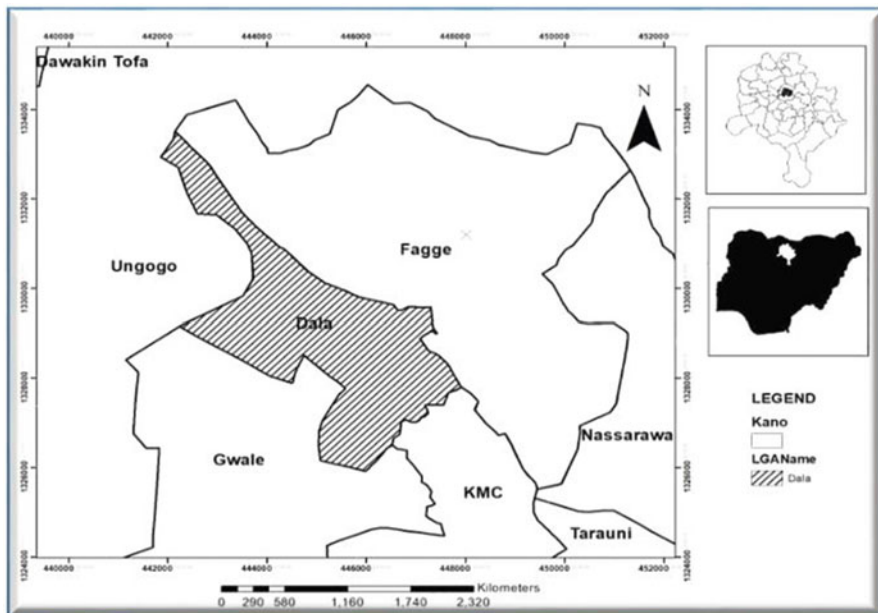
On the other hand, Devkota et al. (2014) identified the following responses of adaptation strategies at community level undertaken before, during, and after flood event. Responses identified before flood event include management plans, keeping contact information, pre-estimating of flood risk, and producing human resources/trained manpower. Response strategies undertaken during the flood event at community level include perfect communication at community level and selection of makeshift settlement. Proper assessment of flood risk in urban areas is still challenging simply because of its complexity as compared to situation in rural areas. Common flood risk analyses do not usually incorporate social and ecological impacts but exclusively assess economic damages, which can be measured in monetary terms (Haque et al. 2012). Comprehensive approaches which try to integrate economic, ecological, and social impacts are less available (Schanze 2006). Particularly, the latter are frequently omitted due to a lack of suitable data.

There are many studies with different conceptual frameworks for flood vulnerability, risk assessment, and adaptation. For instance, Oculi and Stephenson (2018) observed that one of the earliest “frameworks” of adaptation were based on three attributes: climatic-stimuli, the system that is adapting, and method of adaptation. They also recognized that adaptation strategies can be grouped by timeframe of interest, types of behavior, sector, scale, and level of governance. Adaptation to extreme events such as flood is vital in the present era due to the multifaceted nature of the causes and effects, which is exacerbated due to the increasing population and climate change. The ever-changing and cross-boundary nature of flood risk renders adaptation strategies as very crucial in this period of fluctuating social and environmental conditions (Jongman 2018). Flood adaptation strategies are often intended to minimize impacts on various sectors such as built environment, human health, water quality, and transport infrastructures (Wilby and Keenan 2012). The efficient and effective adaptation strategies should have the services and facilities to slow flood waters; use nature-based solutions, early warning systems, and financing schemes to tackle and reduce the economic loss; and practice risk-informed land planning (Jongman 2018).

---

## Observing the Nature of Flood Risk Situation in Kano City

The sites observed in this chapter are located in Dala Local Government Area (LGA), which is the nucleus of the ancient Kano city in northern Nigeria. It is named after the Dala, a residual hill which is the original site from which the city emerged since prehistoric times. The area is located around between latitude  $12^{\circ} 00' 00''$  N to  $12^{\circ} 03' 21''$  N and Longitude  $8^{\circ} 27' 30''$  E to  $8^{\circ} 31' 40''$  E. (Fig. 1).



**Fig. 1** Map of urban Kano showing the location of Dala Local Government Area

This LGA covers a total land area of about 19 km<sup>2</sup> and total population of 415,777 as of 2006 national population and housing census. There was significant increase in the natural population in the state and the study area. The natural increase was estimated to have risen from 2.51% in 1960s to 3.3% in 1980s and 4.5% till date, although the urban growth rate is about 5.5% annually (Mustapha et al. 2014). This implies that the area is a high density core urban settlement and given its nature of terrain is vulnerable to flooding. Previous studies suggested the importance of socioecological systems in understanding the urban environment in Kano (Barau et al. 2013).

## Relief and Geology

Relief of the state is said to be 80% of composed basement which comprises of marbles, granites, and gneisses (Salami et al. 2016). Jakara River is underlain by crystalline Basement complex of pre-Cambrian origin which losses its identity by disappearing into the Chad Formation. Crystalline basement of pre-Cambrian forms the underline of River Jakara, made up of granites extending to Gabasawa toward East and Yadai toward North. This river serves as the natural drain in the study which collects runoff from different tributaries. This geological setting suggests that the study area is susceptible to flood based on its largely impervious surface.

## Climate and Hydrology

The climate of the state is tropical wet and dry type according to Koppen's classification, although climatic changes are believed to have occurred in the past. The climate features in Kano as a whole are typical of West African savannah. Temperature in the region is generally high all year round, together with gradual increase every season. It can be said to be higher usually from January to April which may reach as high as 43 °C, respectively (Mustapha et al. 2014). According to Sanni and Okhimamhe (2009), the annual rainfall values are unpredictable from 1 year to another. For instance, 1999, 2004, 2010, and 2012 witnessed highest annual values in both temperature and rainfall, that is to say, above normal, compared to previous years.

---

## Research Data

Primary data were collected using questionnaire, field observations, field surveys, and in-depth interview. The questionnaires were administered to household heads and/or adult respondents in each residence that were within the 100 m radius of flood-prone areas. This strategy enabled the researchers to identify factors that exacerbate flooding and types of response undertaken to lessen flood risk. Initially, the authors worked with communities to identify the flood hotspots in addition to observations made during previous flood events in the study area.

Global Positioning System (GPS) was used during field survey to take the coordinates of the flood-prone areas which was later imported into the Google Earth for spatial representation of the flood prone areas which was also used in generating the Digital Elevation Model (DEM) and contour map of the study area to analyze vividly the nature of terrain as well as contour of the study area. ArcGIS 10.4 was used to generate the location map and flood-prone areas respectively. Google Earth was used to produce the satellite imagery which was used for spatial representation, while interview was used to source institutional responses to flood risk in the study area, respectively. Interview was conducted in State Emergency Relief and Rehabilitation Agency (SERERA) and Kano State Urban Planning and Development Authority (KNUPDA) with key informant on flood risk and adaptation measures in the study area. This further aid in determining the extent to which these institutions respond to flooding.

Secondary data was sourced through searching the keywords with the aid of Google Scholar (i.e., flood, risk, flood risk, adaptation, and adaptation measures) from scholarly peer-reviewed journals, books, and government archive which provided proper understanding of the research problem at local and global level. The information sourced provided an insight to the researcher on flood risk, flood impacts, its causes, as well as factors that exacerbate flooding.

The questionnaire was administered to the seven (7) flood-prone clusters (462 houses) which include Kofar Ruwa, Kwanar Taya, Gwammaja, Babban Layi, behind Filin Dantata, Lunkwi, and adjacent Gidan Baban Gwari, respectively. Two

hundred and seventeen (217) copies of questionnaires were randomly distributed to the residents within 100 meter radius of each flood-prone area (31 for each zone for equal and unbiased representation) using the simple random sampling techniques. However, only one hundred and ninety six (196) copies of the distributed questionnaires were retrieved due to loss and failure to fill by the residents. Questions asked were tailored toward identification of causes of flood, factors that exacerbate flooding, as well as resident adaptation measures to flood risk in the study area. In addition, data related to demography and socioeconomic characteristics were also captured. The sampling size adopted for this study was determined using Taro Yamane's formula (1967) with 95% confidence level. The formula is given as

$$n = \frac{N}{1 + N(e)^2}$$

where

$n$  = Sample size required

$N$  = Number of population in which the sample will be drawn (462 houses)

$e$  = Margin of error, given as 0.05

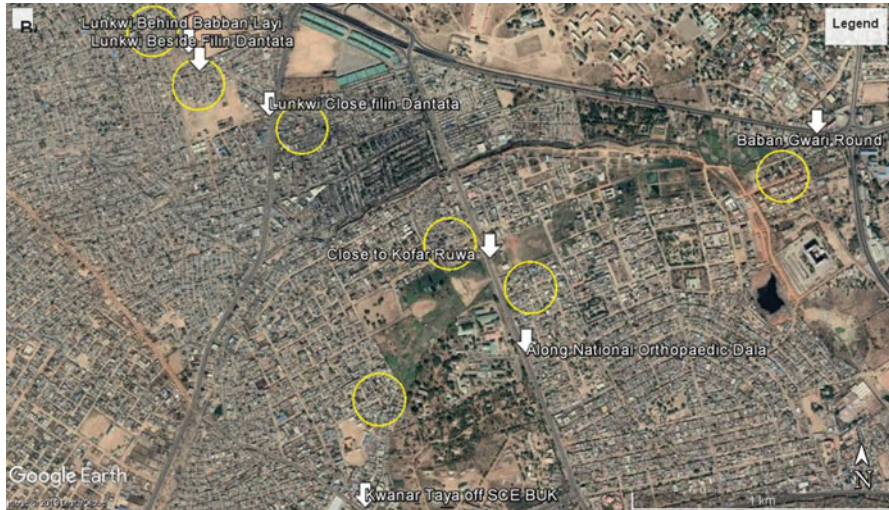
1 = Constant.

$$n = \frac{462}{1 + 462(0.05)^2}$$

$$n = 214.3851508121/7 = 30.626450116. \text{ (Akukwe 2014)}$$

After calculating the sample size by substituting the number of dwelling units (462) into the Yamane formula, the number of sample was 214.3851508121 houses. Dividing this number by the number of flood-prone areas (7) yielded 30.626450116 houses respectively. Therefore, in order to obtain a reliable data, researcher rounded up the sample size to 31 dwellings per each flood-prone area (Fig. 2). Thus, a total of 217 sample size emerged out of 462 sample frame. For convenience and transparency, nine (9) variables were used which include heavy rainfall, poor drainage facilities, slope and topography of the area, dumping of refuse in drainages, blockage of drainage channels, impervious surface, absence of drainage channels, and unplanned development along floodplains. The targeted respondents on a normal circumstances were the household heads, but in a scenario where the household heads were not around, an adult respondent from each dwelling was selected to fill in the required questions based on 5-point Likert scale from Strongly Agree (SA = 5) to Strongly Disagree (SD = 1). This procedure was adopted from a study conducted by Devkota et al. (2014).

Institutional responses were obtained through an in-depth interview with key informants from Kano State Emergency Relief and Rehabilitation Agency (SERERA) and Kano State Urban Planning and Development Authority (KNUPDA). In SERERA, the interview was oriented toward past flood damages,



**Fig. 2** Google image showing flood-prone areas and houses within the 100 m radius of each other. (Source: Authors’ Field Survey 2019)

existing adaptive measures to respond to flood hazard for pre-, during, and post-flood events. This information was relevant to the study because it helped in determining the extent to which the stipulated hazard in the study area was responded to. In KNUPDA, issues raised were concerning planning regulations around the flood-prone areas. This information was relevant to the study because it further helped the researchers to bring out the level of compliance (public) to adapt to the problems of flood-prone area or otherwise. In all the cases, the interview was recorded (with permission of respondents) using phone audio recorder, which was subsequently transcribed to a verbatim record.

Five-point Likert scale and weighted average index (WAI) on the basis of “Highly Applicable” to “Very Less Applicable” were used for analysis of the questionnaire. The first part of the questionnaire was demographic and socioeconomic information of the respondents. These were analyzed using SPSS, and the results were represented in simple tables, charts, and graphs. ArcGIS 10.4 and Surfer software were used to draw and analyze the digital elevation model and contour map of the study area. While community responses were collected before, during, and after flooding by the public were analyzed using weighted average index (WAI) against a scale of 1 to 5. The adaptation strategies for each respondent were rank based on the weighted average index (WAI) which is given as

$$WAI = \frac{F_1 \times W_1 + F_2 \times W_2 + F_3 \times W_3 + F_4 \times W_4 + F_5 \times W_5}{F_1 + F_2 + F_3 + F_4 + F_5}$$

$$WAI = \frac{\sum f_i \times W_i}{\sum f_i}$$

where

F = frequency of the respondents

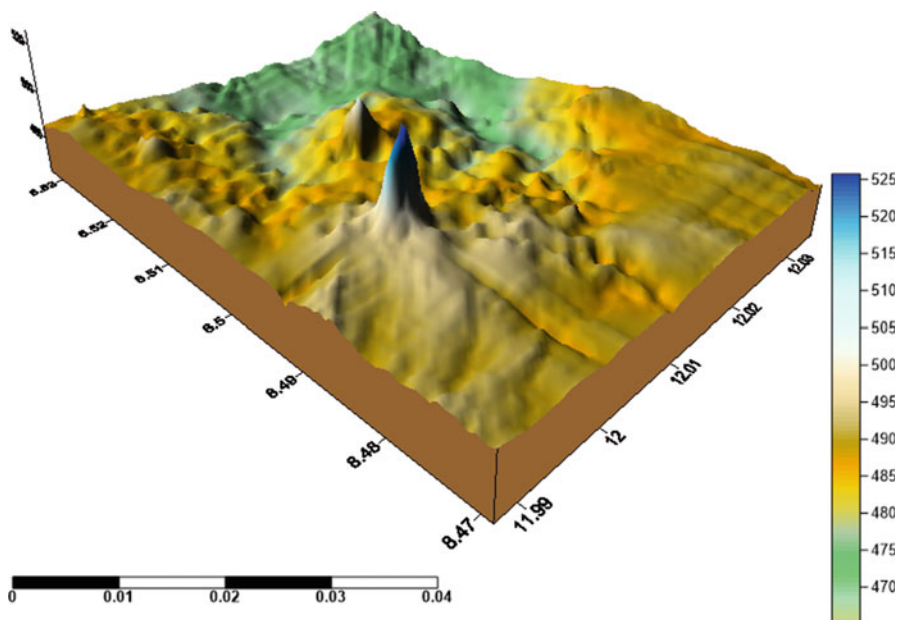
W = weight of each scale

i = weight

**Note** (5 = highly applicable, 4 = applicable, 3 = moderately applicable, 2 = less applicable and 1 = very less applicable) (Devkota et al. 2014). This generated the measures and/or strategies that were mostly applicable and least applicable by the respondents in the study area.

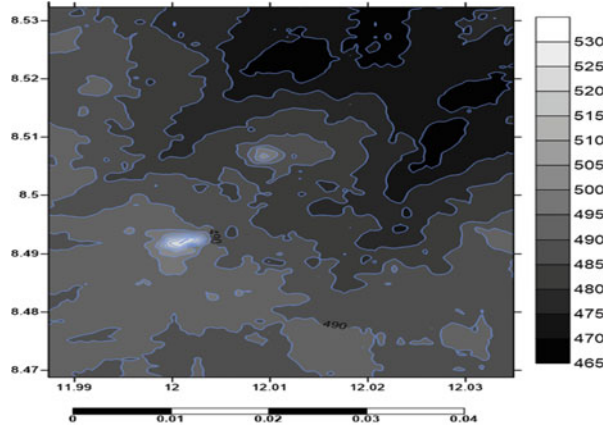
### Digital Elevation Model (DEM) of the Study Area

The digital elevation model (DEM) as illustrated in Fig. 3 revealed the elevation of the study area from which the blue shades represent the areas with the highest elevation 520–525 m above sea level (Dala hill), while the green represents the areas with the lowest elevation 470–475 in the study area respectively. These green shades on the DEM represent the locations of the flood-prone areas. It is apparent that after rainfall the stormwater radiates in a centrifugal direction reaching the lowest elevation (flood prone areas) as natural drains. However, as built-up areas, they easily become flooded.



**Fig. 3** Digital elevation model (DEM) of the study area showing variation of elevation

**Fig. 4** Contour map of the study area. The lighter spots depict areas with highland, while the darker spots represent areas with low land



The green shades represent lowlands, while the blue shades represent highland areas (Dala hill) in the study area.

On the other hand, the contour map (Fig. 4) illustrates the variation of elevation of the study area. The white portion represents the point with the highest elevation (530 m), while the dark portion represents the points with lowest elevation (465–470 m). From these, it can be deduced that elevation still determines floodability of even highly urbanized areas.

## Socioeconomic Characteristics of the Residents

The tendency of flood risk is not the same for all people although all may be situated in a flood-prone areas. It varies considerably with demographic and social characteristics. Although flood risk presents significant health burden worldwide, socioeconomic status is closely related to being flooded or otherwise (Aerts et al. 2018). This section explains the socioeconomic characteristics of the residents in the study area which cover residence, gender, age, marital status, educational level, occupation, average monthly income, housing condition, and construction material used.

## Socioeconomic Characteristics of the Respondent in the Study Area

Table 4 revealed the respondent residential locations of the respondents out of which (28) 14.3% were from Kofar Ruwa, (26) 13.3% from Kwanar Taya, (30) 15.3% from Gwammaja, (27) 13.8% from Babban Layi, (29)14.8% from behind Filin Dantata, (30) 15.3% from Lunkwi, and (26) 13.3% from Gidan Baban Gwari which constitute the sum of 196 respondents. Gender is another important variable in any research of this nature. The gender distribution of respondents revealed dominance of male



respondents. Male respondents featured more than female as they dominate household headship. Again their female counterparts were not freely available to interact with researchers due to cultural barriers in the study area. In general, there is an indication that majority of the respondents are still in their active and productive age. Age is an important attribute that helps in understanding people's perception about a given phenomenon. And with regard to flood risk and adaptation, it helps in improving the methods to be used in adapting to risk as well as mitigating its impact.

The perception and attitudes of an individual due to marital status may differ; findings presented in Table 4 showed the dominance of married respondents in the study area. In addition, marital status is relevant to the study because married people will be more willing to initiate coping strategies in trying to reduce potential losses than the unmarried population simply because they are more attached to the community, and it is assumed that each married person has apartment which is in the long run liable to flood risk. Household size is important to understand socioeconomic status and vulnerability of households. In this context, it is assumed that the larger the household size, the more is the risk of losing more lives and/or property and vice versa.

Knowledge influences reasoning, attitudes, and understanding of individuals from a given social phenomenon. The findings presented in Table 4 also outlined respondents' level of education where (71) 36.2% has tertiary education and (53) 27.0% with informal education, while (59) 30.1% and (13) 6.6% were having only secondary and primary level of education, respectively. This is an indication that majority of the respondents were literate and thus capable of providing adequate and relevant information with regard to flood risk and adaptation measures in the study area.

Occupation or livelihood is another important factor of consideration as it determines people's choice of residence. Thus, the social class of individuals determines their area of residence. It has been established that the more comfortable and secured areas of residence are occupied by the richer households while the less privileged are left with the marginal areas (Salami et al. 2016). In addition, income is an important determinant which is congruent with income and occupation. The situation in the study area in relation to income further highlights what is known with regard to the poor who occupy areas associated with unplanned urban growth and substandard informal settlements on floodplains among other things (Salami et al. 2016).

Age of building is another important determinants of consideration simply because building has a lifespan just like humans. Buildings deteriorate with time and thus become more exposed to destructive flood impacts. Findings revealed that with exclusion of some buildings among which are Government Girls College, Dala, and National Orthopaedic Hospital majority of the buildings in the area have undergone transformation. This implies that majority of the buildings were constructed not so long, thus a concrete evidence of recent encroachment on open spaces and changes in building materials. Building materials play important role in proofing water absorption. Such changes in urban morphology are said to have increased flood events in urban Kano which covers the study area (Barau 2015) (Table 1).

**Table 1** Showing frequency and percentage response on the socioeconomic characteristics of the respondent

Gender	Frequency	Percent
Male	150	76.5
Female	46	23.5
<b>Total</b>	<b>196</b>	<b>100.0</b>
<b>Age</b>		
18–25 years	57	29.1
26–32 years	51	26.0
33–39 years	54	27.6
40 years and above	34	17.3
<b>Total.</b>	<b>196</b>	<b>100.0</b>
<b>Marital status</b>		
Single	90	45.9
Married	106	54.1
<b>Total</b>	<b>196</b>	<b>100.0</b>
<b>Household size</b>		
0–4	82	41.8
5–9	52	26.5
10–14	49	25.0
15 and above. . .	13	6.6
<b>Total</b>	<b>196</b>	<b>100.0</b>
<b>Occupation</b>		
Civil servants	32	16.3
Traders	97	49.5
Farmers	21	10.7
Others	46	23.5
<b>Total</b>	<b>196</b>	<b>100.0</b>
<b>Average monthly income</b>		
<20,000	63	32.1
20,000–40,000	49	25.0
40,000–60,000	36	18.4
60,000 and above	21	10.7
<b>Total</b>	<b>196</b>	<b>100.0</b>
<b>Age of building</b>		
0–5 years	46	23.5
5–10 years	78	39.8
10–15 years	41	20.9
15 years and above	31	15.8
<b>Total</b>	<b>196</b>	<b>100.0</b>
<b>Building construction material</b>		
Mud	40	20.4
Cement block	154	78.6
Bamboo	0	0
Others	2	1

(continued)

**Table 1** (continued)

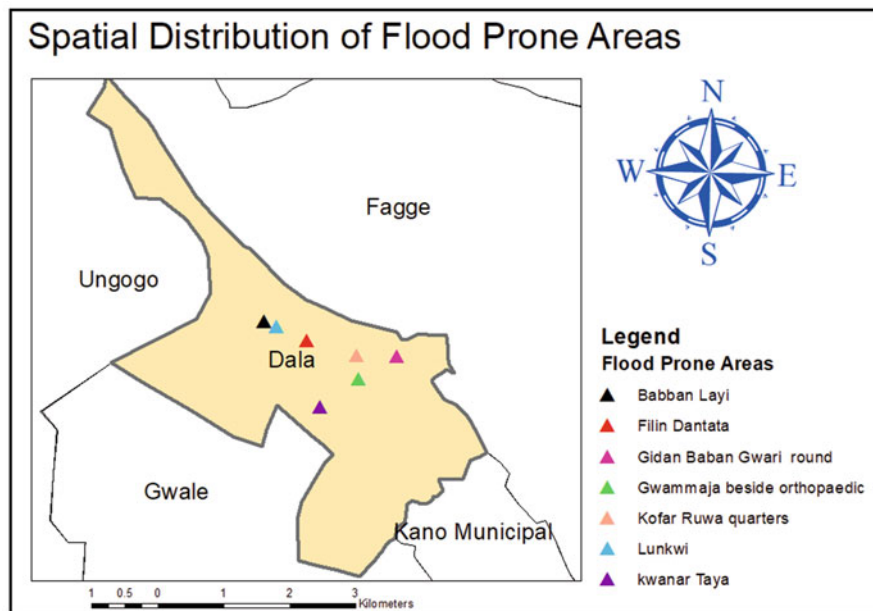
Gender	Frequency	Percent
<b>Total</b>	<b>196</b>	<b>100.0</b>
<b>Condition of buildings</b>		
Need minor repair	101	51.5
Need major repair	39	19.9
In good condition	56	28.6
<b>Total</b>	<b>196</b>	<b>100.0</b>

## Public Perception and Current State of Flood Risk and Adaptation

Adaptation may include modifying susceptibility, increasing response capacity, and reducing exposure (Merz et al. 2010); thus, this section focused on community perception of flood risk, vulnerability profiles of the households regarding flood experience, as well as the residents' adaptation (coping) mechanisms against flood risk (i.e., actions taken by the public prior to, during, and after flood event) in the study area. Questionnaire survey was used to assess the level of flood severity and whether or not affected previously. The following parameters "severely affected," "affected but not severe," and/or "not affected at all" were used in generating this information which revealed that (68) 34.7% of the respondents were not affected at all, (91) 46.4% were affected but not severe, while (37) 18.9% of the respondents were severely affected by previous flood havoc in the study area. In order words, it can be deduced that 65.3% of the sampled population were affected by flood disaster in the study area (Fig. 5).

The factors that cause and exacerbate flooding in the study area based on the outcome of the current study include heavy rainfall, dumping of refuse on drainages, as well as blockage of drainage among others as shown in Table 2. These factors were ranked based on average mean score ( $\bar{X}$ ) of each factor and sum weighted value (SWV) of responses derived from questionnaires.

Findings as presented in Table 2 established that the indicator with the highest rating is rainfall with a weighted value of 4.77 and a positive deviation of 0.82 from the mean, while the least rated indicator was impervious surfaces with a weighted value of 3.08 and a negative deviation of  $-0.87$  from the mean, respectively. This denotes that heavy rainfall is the major cause of flood in the study area. Thus, climate change appears to be a major factor and driver of flooding incidents in urban areas of developing countries. Therefore, it is imperative for urban areas to embrace priority action to tackle climate change both as local and global challenge (Bai et al. 2018). The study further revealed that out of the nine indicators used, five had a positive deviation which are the major causes of flooding in the study area, while four had a negative deviation from the mean. The indicators with positive deviation about the mean include heavy rainfall (with a weighted value of 4.77 and a positive mean of 0.82), dumping of refuse and/or waste on drainages (with a weighted value of 4.42 and a positive mean of



**Fig. 5** Spatial distribution of the flood-prone areas in Dala LGA. (Source: Author 2019)

**Table 2** Causes of flood in the study area with their ranks in descending order

Causes	SA	A	U	D	SD	SWV	X	$\bar{X} - X$	Ranks
Heavy rainfall	154	40	0	2	0	934	4.77	0.82	1st
dumping of waste/ refuse on drainages	110	70	4	12	0	866	4.42	0.47	2nd
Slope and topography of the area	86	66	22	20	2	802	4.09	0.14	3rd
Blockage of drainage channels	82	77	9	21	7	794	4.05	0.1	4th
Poor drainage facilities	79	69	26	22	0	793	4.05	0.1	5th
Unplanned development along flood plain	40	97	41	15	3	744	3.80	-0.15	6th
Absence of drainage channels	63	64	28	37	4	733	3.74	-0.21	7th
Soil type	11	72	68	38	7	630	3.21	-0.37	8th
Impervious surface	26	41	77	26	26	603	3.08	-0.87	9th
<b>Total</b>	<b>651</b>	<b>596</b>	<b>275</b>	<b>193</b>	<b>49</b>	<b>6973</b>	<b>35.58</b>	-	-

Source: Authors' Field Survey

Note: SA (5) = STRONGLY AGREE, A (4) = AGREE, U (3) = UNDECIDED, D (2) = DIS-AGREE, SD (1) = STRONGLY DISAGREE, SWV = Sum of Weighted Value, X = Mean score.  $\bar{X}$  = Mean deviation

0.47), slope and topography of the area (with a weighted value of 4.09 and a positive mean of 0.14), blockage of drainage channels (with a weighted value of 4.05 and a positive mean of 0.1), and poor drainage facilities (with a weighted value of 4.05 and a positive mean of 0.1). On the other hand, the indicators with negative deviation about the mean were unplanned development along floodplains (with a weighted value of 3.80 and a negative mean of  $-0.15$ ), absence of drainage channels (with a weighted value of 3.74 and a negative mean of  $-0.21$ ), soil type (with a weighted value of 3.21 and a negative mean of  $-0.37$ ), and impervious surface (with a weighted value of 3.08 and a negative mean of  $-0.87$ ).

The results presented here highlight the importance of socioecological dimensions of flooding because of close and tangential relations between human and naturally induced drivers of climate change, landscape, ecology, and infrastructural development. It is equally important to recognize that the impact of human transformation of landscape and/or misuse of infrastructure galvanize negative effects of climate change in the society. For instance, as evident from Figs. 6, 7, and 8, people erect structure in areas where the morphology is not favorable, and hence flood waters cause destruction to buildings (Fig. 6). On the other hand, indiscriminate dumping of waste causes siltation and sedimentation of waterways which cause flooding in the study area (Figs. 7, 8, and 9). In other words, people need to be educated and informed about climate change as it is obvious that level of education does not sufficiently make people more informed. Hence, it is critical to follow multiple strategies of educating and communicating climate change to the public (Barau and Tanko 2018).



**Fig. 6** Abandoned development in a low-lying area due to adverse effect of flooding in the study area (Kofar Ruwa quarters). (Source: Field Survey 2019)



**Fig. 7** Poor drainage filled up with silt, obstructing the free flow of storm water along Dala Orthopaedics Gwammaja. (Source: Field Survey 2019)



**Fig. 8** Indiscriminate dumping of waste along drainage in the study area. (Source: Field Survey 2019)

---

## Public and Institutional Adaptation Response to Floods in the Study Area

Public and institutional response to flood risk is one of the objectives of the study. Here, public response to flood risk was collected through observation and questionnaire survey, while the institutional response was collected through an interview with key informants in the specified planning and environment agencies. Firstly, with



**Fig. 9** Area submerged during the 2019 flood in Kwanar Taya. (Source authors' field work 2019)

regard to people's effort to prevent flood risks which some researchers called it do-it-yourself (DIY) adaptation (Udelmann Rodrigues 2019), a field survey revealed that the residents of the study area also employed this strategy through the use of sand bags, raising of walls, and de-siltation among others to divert flood water away from their residential area (community), and this was specifically observed in Gwammaja besides Dala National Orthopedics Hospital and also at Kwanar Taya which is another section of the study site. All these efforts represent the community's local responses to reduce potential harm and adverse effects of flood incidents. However, due to uncertainty of rainfall and anthropogenic factors that induce the floods, the community members can hardly achieve complete defense of their locality as it is beyond their capacity to prevent floods. This situation remarkably improve our understanding of the DIY adaptation efforts and at the same time the indispensability of municipalities to support the efforts of vulnerable communities particularly those inhabiting marginal areas that are more exposed to climate change.

The study further revealed that most of these areas that were subjected to frequent flood hazard have developed different flood risk management approaches for pre-flood, during, and post-flood period. Table 3 outlines the residents' coping strategies undertaken before flood/rainy season. Clearing of waterways appeared to be the first with WAI of 4.45 and followed by de-siltation as the second most practiced strategy with WAI of 3.77; widening of drainage channels was ranked third with WAI of 3.51, and producing human resource/trained manpower was ranked fourth with WAI of 3.48. Likewise use of metal sheeting and/or sandbag was ranked fifth with WAI of 3.26, while sharing of contact information was ranked sixth with WAI of 2.86 as the least strategy practiced in the study area, respectively.

**Table 3** Pre-flood adaptation strategies at community level (N = 196)

Response	HA	A	MA	LA	VLA	SMV	WAI ( $\bar{X}$ )	X	( $\bar{X}$ -X)	Ranks
Clear water ways to remove dirt	128	41	21	0	6	873	4.45	3.56	0.89	1st
De-siltation	38	115	21	3	19	738	3.77		0.21	2nd
Share contact information	15	53	41	63	24	560	2.86		-0.7	6th
Produce trained manpower	44	60	56	19	17	638	3.48		-0.08	4th
Widened drainage channels	26	106	27	16	21	688	3.51		-0.05	3rd
Use of metal sheeting/sandbags	25	84	37	17	33	639	3.26		-0.3	5th
<b>Total</b>	<b>276</b>	<b>459</b>	<b>203</b>	<b>118</b>	<b>304</b>	<b>4136</b>	<b>21.33</b>			

Source: Author's Field Survey 2019

Note: **HA** = Highly Applicable, **A** = Applicable, **MA** = Moderately Applicable, **LA** = Less Applicable, **VLA** = Very Less Applicable, **WAI** = weighted Average Index, **SMV** = sum of mean variable

The current study has further revealed that community adaptation planning is undertaken at various scales reflecting, in particular, the seasonality of rainfall. For instance, among the 196 respondents, 128 (63.5%) stated that clearing of drainages in anticipation of rainy season was a highly considered strategy for improving the drainage capacity and its functionality. This strategy was regarded as the most relevant flood risk adaptation strategy in the study area which is followed by 115 (58.7%) of the respondent that mentioned de-siltation as the next most important adaptation strategy that is used in the community (see Table 3). Again, it is important to note that local governments have actually failed in delivering their responsibility of environmental upkeep which can be carried out through increased financing and enforcement environmental and sanitary provisions. In other words, while the DIY role played by the communities is commendable, the total neglect of vulnerable communities is deplorable. In the interest of environmental justice and social equality and inclusion, it becomes imperative on local governments in developing countries to consider integrated and larger adaptation strategy that will tackle community level vulnerabilities and strategic efforts such as DIY as a means of achieving an inclusive adaptation to flood risk. The need to focus on flooding is very important as it has been identified as universal issue in global climate change risk which affects more people than any other form of disaster (Nkwunonwo et al. 2016; Salami et al. 2016).



---

## Flood Adaptation Strategies at Community Level

The above subsection dwelt on pre-flood DIY efforts, while Table 4 in this subsection shows the residents' coping strategies during flood/rainy season based on applicability of various adaptation strategies. According to the outcome of the survey, selection of safer place to stay was ranked first (most applicable) in the study area with 3.85 WAI. Whereas relocation to the nearest neighborhood until after rainfall was second with 3.82 WAI, the third most applicable strategy was taking care of the children, the aged, and people living with disability (PWDs) with 3.68 WAI. Here, the results point out the critical role of decision-making as to how to respond to rainy and floodable days in these urban communities. One of the limitations of this study is its inability to explore the nature of decision-making with respect to displacement of people.

Moreover, the study revealed that out of the total respondents, 86 (43.9%) respondents mentioned selecting safer location to stay, while 71 (36.2%) mentioned taking care of the children, the aged, and PWDs as the most applicable strategy practiced during flood in the community. Similarly, temporary relocation to nearest neighborhood until after flooding 112 (57.1%), perfect communication at community level for assistance 65 (33.2%), and taking care of the affected people 73 (37.2%) were enlisted among applicable (although not highly applicable) strategies in the community for adapting to flood risk during flood. The relocation sites are mostly homes of friends and relations that have raised buildings and more spaces to accommodate people. Even under this scenario, DIY adaptation strategy is very active and effective. For instance, digging of channels to divert waters 70 (35.7%) and praying for lesser rain 58 (29.6%) were mentioned among moderately applicable strategies to adapt during flood. The total loss of confidence in the government manifested clearly as 27.6% of the respondents mentioned the government intervention.

---

## Post-flood Community Response on Adaptation Strategies

Flooding can have immediate-, short-, and long-term impacts on urban communities. As such, community adaptation responses may extend to beyond the rainy season. In the context of this study, communities in the study area lack the appropriate solutions but hang on the adaptation strategies that they have developed over time. Nevertheless, our questionnaire created a kind of public conversation among the respondents who revealed their thoughts on what seems to be their perceptions of best adaptation strategies. In this regard, Table 5 outlines the roles of clearing blocked drainages in the community which was ranked as the most applicable flood adaptation strategies with a WAI of 4.11. People themselves have acknowledged the role of education as a driver of community adaptation, and this knowledge will in a long way support and enhance their capacity for DIY adaptation. This further revealed that no relief materials were received by the public in these flood-prone areas. Again, as can be seen in Table 5, the respondents stressed the need for equality in distribution of relief

**Table 4** During flood adaptation strategies at community level (N = 196)

S/N	Response	HA	A	MA	LA	VLA	SMV	WAI ( $\bar{X}$ )	X	( $\bar{X}$ -X)	Ranks
1	Select safer location to stay	86	64	6	11	29	755	3.85	3,41	0.44	1st
2	Temporary relocate to the nearest neighborhood until after flooding	40	112	22	12	10	748	3.82		0.41	2nd
3	Take care of the children, the aged and PWD's	71	56	31	11	27	721	3.68		0.27	3rd
4	Perfect communication at community level for assistance	57	65	26	28	20	699	3.57		0.16	4th
5	Take care of the affected people	30	73	55	12	26	657	3.35		-0.06	5th
6	Digging channels to draw water away from dwellings	38	44	70	24	20	644	3.29		-0.12	6th
7	Pray for lesser rain	35	47	58	24	32	617	3.15		-0.26	7th
8	Do nothing and wait for government assistance	13	41	47	41	54	506	2.58		-0.83	8th
	<b>Total</b>	<b>370</b>	<b>502</b>	<b>315</b>	<b>163</b>	<b>218</b>	<b>5347</b>	<b>27.29</b>			

Source: Authors' Field Survey 2019

**Table 5** Post-flood adaptation strategies at community level responses (N = 196)

S/N	Response	HA	A	MA	LA	VLA	SMV	WAI		Rank	
								$(\bar{X})$	X		
1	Seeking of help for clearing blocked drainages in the community	120	23	28	4	21	805	4.11		1.43	1st
2	Inform the community/ward head on areas mostly affected	15	101	41	29	10	670	3.42		0.74	2nd
3	Engage on public awareness campaign on flood risk management	40	32	40	25	59	557	2.84	2.68	0.16	3rd
4	Collaborate with Government and other agencies	0	2	23	56	115	304	1.55		-1.13	4th
5	Equal distribution of relief resources, if any	0	11	23	17	145	292	1.49		-1.19	5th
	<b>Total</b>	<b>175</b>	<b>169</b>	<b>155</b>	<b>131</b>	<b>350</b>	<b>2628</b>	<b>13.41</b>			

Source: Authors field work 2019



**Fig. 10** Resident adaptation measures (coping strategy) to flood, to hold back and/or divert flood water away from their residence (Gwammaja)

materials from the public sector if and when at least they come to the victims of flooding. In other words, there is seemingly lack of trust on the government and its agencies for their failure to assist people. While it has been a culture for governments at all levels (local, state, federal) to allocate for disasters such as the recurrent floods, there is dissatisfaction from the side of the vulnerable communities. Again, as can be seen in Figs. 10 and 11, there is evidence of community DIY actions that aim at protecting neighborhoods and their households from recurrent flood incidents.

### **Institutional Flood Adaptation Response Strategies in the Study Area**

Public institutions such as agencies have duty and responsibility to promote adaptation measures within their area of constitutional jurisdiction and governance system operational in a given urban area. Against this backdrop, this study sought for explanations from relevant agencies which in this case are two organizations, namely, Kano State Urban Planning and Development Authority (KNUPDA) and State Emergency Relief and Rehabilitation Agency (SERERA). In the case of KNUPDA, our questions were answered by the Zonal Coordinator who is in charge of development control in the study area. By virtue of his knowledge of the area, he affirmed that “the problem of flood in the local government is not a new phenomenon,” adding that the study site is “among the ancient settlement in the state which existed for long prior to initiation of the Control Department (CD) or KNUPDA itself.” This view impliedly suggests that probably the planning authority has been



**Fig. 11** De-siltation of drainages to improve free flow of storm water, but not properly evacuated which have tendency of finding its way back into the drainage

overwhelmed with the flood incident in the study area and possibly lacks sustainable solutions for the challenge. Given the experience of the United States, it is important for authorities in developing countries to tap on community initiatives in dealing with flood hazards (Noonan and Sadiq 2018).

Furthermore, the officer argued that “increased population and urbanization make the community continue to become more congested.” In addition, he mentioned that there were numerous buildings that were developed without planning approval and that majority of the area was not properly planned or designed. Accordingly, such haphazard developments are among the key drivers of perennial floods. The situation is also not unconnected with inadequate drainages and encroachment of open spaces by private buildings among others. However, the officer maintained that some areas were but still suffer from lack of proper implementation of design principles and enforcement of planning regulations. Hence, he argued that “adaptation strategy employed is insisting on people to seek proper approval and development permit before construction.” In doing so, KNUPDA provides prospective developers with adequate standards in developing their properties. According to him, they also convey messages to the ward heads as a mean of ensuring control of development and stop any development that encroaches floodplain in the Local Government Area which eventually might pose a problem such as environmental hazard.

With regard to the implementation and enforcement of planning regulations, the key informant asserts that “some officials are always in constant inspection of the area and these officers are responsible for reporting (immediately) any suspicious development.” Another notable problem noted by the officer is the lack of proper waste collection and disposal infrastructure in the ancient city of Kano. Although poor waste disposal is invariably connected to flooding, the officer noted that waste

management is no longer the business of KNUPDA as it has been assigned to another authority. Nevertheless, he insisted that KNUPDA had severally issued stop work notice and in some instances demolished hazardous structures when they are deemed to constitute a threat to safety. Some areas within and around the study area hardly experience flood incident and attributed that to their interventions in the local government area.

In SERERA, an agency responsible for responding to all forms of disasters in the state, the key informant revealed that they “don’t have pre-flood adaptation measures” because they only embark on emergency response with immediate effect when it is reported to them. This agency does provide parties affected with relief materials ranging from building materials like cement, blocks, nails, and planks, among others. They also embark on assessment reports, making recommendations for relief measures, occasional involvement in the distribution of relief materials, and evacuation of stranded persons in spots of emergency. The respondents added that their personnel were trained on how to rescue individuals from either fire or flood disaster which is sent on special assignment when the need arises.

When asked on whether they have any special plans for the identified flood-prone areas under study, they responded that that they just act in case of emergency and provide relief materials; things provided include mosquito nets, foodstuffs, drugs, mattresses, temporary camping of stranded people, as well as taking care of the aged and children. Their response is mainly on immediate report of accidents, and they work hand in hand with fire service department whose mandate include rescue services.

Based on information given by the key informants, it is obvious there is disconnect between the approaches and philosophies of communities and public institutions responsible for tackling climate disasters and, in particular, flooding. The recurrent floods cause loss and damage to communities, and this situation increases temporary loss of shelter or displacement from their houses. This is an indication of the situation in many developing countries where there is disconnect between planning policy and climate change mitigation and adaptation. It is obvious there is need for capacity building and reorientation of urban climate change governance architectures to enable creation of a broad-based consultations and policy formulations between communities and public agencies. This is necessary because at the moment actions by communities and the agencies do not complement each other. At the same time, there is fragmentation even between and within public organizations responsible for urban planning, waste management, and rescue operations.

---

## Conclusion

This chapter is premised on the socioecological notions which enables to gain a better understanding of flood adaptation response in urban areas of developing countries. In other words, it is imperative to look into the connections of human and social dimension of environmental and climate change as we observe climate vulnerability in cities and towns. This chapter has established the critical role of the

physical environmental features such as relief and topography and their interface with flood incidence in high-density urban areas. Thus, it is crucial to recognize the role of physical terrain when planning and designing human settlements in this age of changing climate. In relation to this, municipalities in developing countries should prioritize the importance of systematic environmental data in urban planning climate adaptation strategies. The recurrence of flooding in cities and towns cannot be disconnected with neglect of terrain factor in stormwater overflows and its redistribution within the built-up areas. Again, as urban surface is becoming more impervious and waterproofed, it is important to reconsider the place of nature in tackling climate change.

The neglect of nature in urban development is closely followed by neglect of people in the effective management of climate crisis and, in particular, perennial floods that ravage cities and towns. It appears that in developing countries public agencies operate in silos even when there is evidence of commitments to addressing climate challenges. Therefore, it is high time to address such gaps and disconnects which cause failures and loss of time and resources due to such unyielding interventions. Invariably, the persistence of fragmented efforts leaves public to suffer resounding devastation of infrastructure as well as people's dwelling places and sources of livelihoods.

More people inhabit urban areas more than ever before in human history, and this human dominance is being challenged by climate change and its impacts. The neglect of climate vulnerable groups inhabiting informal areas has continued in most developing countries. This situation violates the principles and goals of the United Nations' Sustainable Development Goals (SDGs) and, in particular, the SDG 11 – which focus on sustainable human cities and communities. In a situation like this, one of the best options left for the people left out in the schemes of policy and planning is DIY adaptation. This adaptation strategy is found to be effective and useful to many poor and neglected urban citizens in developing countries. Hence, it is imperative on local authorities to support such efforts by working with communities that use this kind of adaptation measures. What is most attractive about DIY adaptation is that it focuses on directly correcting or tackling flood causative and/or multiplier factors. Therefore, researchers and especially climate experts and scientists need to recognize DIY as part of the grassroots efforts and local knowledge and actions which are essential in building global climate adaptation.

---

## References

- Aerts JCJH, Botzen WJ, Clarke KC, Cutter SL, Hall JW, Merz B, Mysiak J, Surminski S, Kunreuther H (2018) Integrating human behaviour dynamics into flood disaster risk assessment. *Nat Clim Change*. <https://doi.org/10.1038/s41558-018-0085-1>
- Akukwe TI (2014) Determinants of flooding in Port Harcourt Metropolis, Nigeria. *Int J Humanit Soc Sci* 19(11):64–72
- Alfieri L, Feyen L, Di Baldassarre G (2016) Increasing flood risk under climate change: a pan-European assessment of the benefits of four adaptation strategies. *Clim Change* 136(3–4): 507–521. <https://doi.org/10.1007/s10584-016-1641-1>

- Azua S et al (2019) Spatial multi-criteria analysis for mapping of flood vulnerable areas in Fagge Local Government Area of Kano State, Nigeria. *FUTY J Environ* 13(1):23–35
- Bai X, Dawson RJ, Ürge-Vorsatz D, Delgado GC, Salisu Barau A, Dhakal S, Dodman D, Leonardsen L, Masson-Delmotte V, Roberts DC, Schultz S (2018) Six research priorities for cities and climate change. *Nature* 555(7694):23–25. <https://doi.org/10.1038/d41586-018-02409-z>
- Barau AS (2008) An appraisal of climate change risks and institutional adaptation strategies in Kano State. In Association of Nigerian Geographers 50 th Annual Conference Book of Proceedings. The Department of Geography and Regional Planning, University of Calabar, Index Book Publishers, Calabar, p 113–120
- Barau A, Tanko AI (2018) In search of new narratives for informed decisions on climate change crisis in the African Drylands. In: Leal Filho W, et al (eds) *Handbook of climate change communication: vol 3, Climate change management*. Springer International Publishing, pp 1–20. [https://doi.org/10.1007/978-3-319-70479-1\\_1](https://doi.org/10.1007/978-3-319-70479-1_1)
- Barau AS, Ludin ANM, Said I (2013) Socio-ecological systems and biodiversity conservation in African city: insights from Kano Emir’s Palace gardens. *Urban Ecosyst*. <https://doi.org/10.1007/s11252-012-0276-x>
- Barau AS, Maconachie R, Ludin ANM, Abdulhamid A (2015) Urban morphology dynamics and environmental change in Kano, Nigeria. *Land Use Policy* 42:307–317
- Cirella GT, Iyalomhe FO (2019) Determinants of flooding and strategies for mitigation: two-year case study of Benin City, pp 1–15. <https://doi.org/10.3390/geosciences9030136>
- Colenbrander S, Barau A (2019) Planning and financing urban development in the context of the climate crisis. *Int J Urban Sustain Dev* 11(3):237–244. <https://doi.org/10.1080/19463138.2019.1673529>
- Devkota RP, Cockfield G, Maraseni TN (2014) Perceived community-based flood adaptation strategies under climate change in Nepal. August. <https://doi.org/10.1504/IJGW.2014.058758>
- Dhiman R, Vishnuradhan R, Arun TIE (2019) Flood risk and adaptation in Indian coastal cities: recent scenarios. *Appl Water Sci* 9(1):1–16. <https://doi.org/10.1007/s13201-018-0881-9>
- Fuchs S, Karagiorgos K, Kitikidou K, Maris F, Paparrizos S, Thaler T (2017) Flood risk perception and adaptation capacity: a contribution to the socio-hydrology debate. *Hydrol Earth Syst Sci*. <https://doi.org/10.5194/hess-21-3183-2017>
- Haque AN, Grafakos S, Huijsman M (2012) Participatory integrated assessment of flood protection measures for climate adaptation in Dhaka. 24(1):197–213. <https://doi.org/10.1177/0956247811433538>
- Jongman B (2018) Effective adaptation to rising flood risk. 9–11. <https://doi.org/10.1038/s41467-018-04396-1>
- Kubal C, Haase D, Meyer V, Scheuer S (2009) Integrated urban flood risk assessment – adapting a multicriteria approach to a city. *Nat Haz Earth Syst Sci* 9:1881–1895
- Merz B, Hall J, Disse M, Schumann A (2010) Fluvial flood risk management in a changing world. *Hydrol Earth Syst Sci* 10:509–527
- Muo A (2015) Evaluating the causes of flooding in six communities in Awka Anambra State of Nigeria. *J Nat Sci Res* 5(4):1–10
- Mustapha A, Yakudima II, Alhaji M, Nabegu AB, Adamu F, Dakata G, Umar YA, Musa BU (2014) Overview of the physical and human setting of Kano. *Research Journal’s Journal of Geography* 1(5):1–12
- Nkwunonwo UC, Whitworth M, Baily B (2016) Review article: a review and critical analysis of the efforts towards urban flood risk management in the Lagos region of Nigeria. 349–369. <https://doi.org/10.5194/nhess-16-349-2016>
- Noonan DS, Sadiq AAA (2018) Flood risk management: exploring the impacts of the community rating system program on poverty and income inequality. *Risk Anal*. <https://doi.org/10.1111/risa.12853>
- Oculi N, Stephenson SR (2018) Conceptualizing climate vulnerability: understanding the negotiating strategies of small island developing states. *Environ Sci Policy* 85:72–80. <https://doi.org/10.1016/j.envsci.2018.03.025>



- Olanrewaju CC, Chitakira M, Olanrewaju OA, Louw E (2019) Impacts of flood disasters in Nigeria: A critical evaluation of health implications and management. *Jamba* 11(1):557
- Parsons M (2019) Extreme floods and river values: a social–ecological perspective. *River Res Appl.* <https://doi.org/10.1002/rra.3355>
- PDNA (2013) Nigeria Post-Disaster Needs Assessment (PDNA) 2012 Floods. May
- Salami RO, Giggins H, Salami R, Meding V (2016) Vulnerability of human settlements to flood risk in the core area of Ibadan metropolis, Nigeria. *Jamba: Journal of Disaster Risk Studies* 9(1)1–14.
- Sanni D, Okhimamhe A (2009) Linking climate change and urbanization in Kano Metropolis and environs in the Sudano-Sahelian Belt of Nigeria, IOP Conf. Series: Earth and Environmental Science 6(2009) 342032. <https://doi.org/10.1088/1755-1307/6/4/342032>
- Schanze J (2006) Flood risk management - a basic framework. In: Schanze J, Zeman E, Marsalek J, editors. *Flood risk management - hazards, vulnerability and mitigation measures*. NATO Science Series. Houten: Springer Netherlands; p. 120
- Soneye A (2014) An overview of humanitarian relief supply chains for victims of perennial flood disasters in Lagos, Nigeria (2010–2012). *J Humanit Log Supply Chain Manag* 4:179–197
- Udelmann Rodrigues C (2019) Climate change and DIY urbanism in Luanda and Maputo: new urban strategies? *Int J Urban Sustain Dev.* <https://doi.org/10.1080/19463138.2019.1585859>
- Verburg PH, Koomen E, Lesschen JP (2012) An assessment of the impact of climate adaptation measures to reduce flood risk on ecosystem services. 473–486. <https://doi.org/10.1007/s10980-012-9715-6>
- Vojtek M, Vojteková J (2016) Flood hazard and flood risk assessment at the local spatial scale: a case study. 5705. <https://doi.org/10.1080/19475705.2016.1166874>
- Wilby RL, Keenan R (2012) Adapting to flood risk under climate change. <https://doi.org/10.1177/0309133312438908>
- Yamane T (1967) *Statistics, An Introductory Analysis*, 2nd Ed., New York: Harper and Row

**Open Access** This chapter is licensed under the terms of the Creative Commons Attribution 4.0 International License (<http://creativecommons.org/licenses/by/4.0/>), which permits use, sharing, adaptation, distribution and reproduction in any medium or format, as long as you give appropriate credit to the original author(s) and the source, provide a link to the Creative Commons license and indicate if changes were made.

The images or other third party material in this chapter are included in the chapter's Creative Commons license, unless indicated otherwise in a credit line to the material. If material is not included in the chapter's Creative Commons license and your intended use is not permitted by statutory regulation or exceeds the permitted use, you will need to obtain permission directly from the copyright holder.





# Global Strategy, Local Action with Biogas Production for Rural Energy Climate Change Impact Reduction

# 67

A. S. Momodu, E. F. Aransiola, T. D. Adepoju, and I. D. Okunade

## Contents

Introduction .....	1382
Literature Review .....	1383
Methodology .....	1385
Digester Design and Development .....	1385
Up-Scaling Biogas Production from Laboratory Experiment .....	1386
Avoided Emission Calculations/Climate Change Impact Reduction .....	1388
Estimation of Life Cycle Costs and Return Streams .....	1388
Business Model Formulation .....	1389
Results and Discussion .....	1390
Scaled Up Biogas Production .....	1390
Avoided Emissions .....	1391
Investment Cost and Variable Cost Stream .....	1392
Life Cycle Costs and Return Streams .....	1392
Business Model Formulation .....	1393
Conclusions and Recommendations .....	1396
References .....	1396

## Abstract

Global climate change impact is predicted to affect various sectors including the energy demand and supply sectors respectively. Combating this impact will require adoption of both global strategy and localized actions. The use of low

This chapter was previously published non-open access with exclusive rights reserved by the Publisher. It has been changed retrospectively to open access under a CC BY 4.0 license and the copyright holder is “The Author(s)”. For further details, please see the license information at the end of the chapter.

A. S. Momodu (✉)

Centre for Energy Research and Development, Obafemi Awolowo University, Ile-Ife, Nigeria

E. F. Aransiola · T. D. Adepoju · I. D. Okunade

Department of Chemical Engineering, Obafemi Awolowo University, Ile-Ife, Nigeria

© The Author(s) 2021

W. Leal Filho et al. (eds.), *African Handbook of Climate Change Adaptation*,  
[https://doi.org/10.1007/978-3-030-45106-6\\_198](https://doi.org/10.1007/978-3-030-45106-6_198)

1381

carbon strategy based on renewables is a global strategy, while waste management of biodegradable materials through the use anaerobic technology to meet energy demand is a local action. Nigeria is among the vulnerable countries to global climate change impact; this is even more aggravated by its dependence on fossil fuel usage as well as poor waste management, which two, contribute significantly to greenhouse gas emissions. This chapter presents analysis of purified compressed biogas production, a waste conversion option, as a local action to meet rural household energy demand and contribute to global strategy of reducing climate change impact. It discusses both technical and business model approaches to upscale a laboratory experimental procedure for biogas production through anaerobic digestion using vegetal wastes. It shows that using anaerobic technology can achieve efficient waste management and at the same time generate energy that can be used to achieve avoided emissions for climate change impact reduction. The study also concludes that upscaling the project will be sustainable for rural energy augmentation as it produces clean and renewable energy, reduces the use of fossil fuels, provides jobs for skilled and unskilled labor, and generates new return streams.

---

**Keywords**

Global strategy · Local action · Waste management · Anaerobic technology · Rural households · Avoided emissions · Business model

---

**Introduction**

Energy is a very crucial input for attaining sustainable development. This has become even more pronounced for growth-driven economies, as those in developing countries as Nigeria. Most energy inputs driving economic activities are currently derived from fossil origin, principally hydrocarbon and solid fuels as firewood. These are not socially, environmentally, and economically efficient and therefore not sustainable. Fossil fuels contribute significantly to greenhouse emissions (Bölük and Mert 2014), while solid fuels produce indoor air pollution (WHO 2015). On the other hand, waste is produced from unwanted and discarded materials of human society (Bharadwaj et al. 2015), which needs to be managed properly. Management of waste is a global phenomenon (Isiaka 2017), although the challenge is more pronounced in developing countries for three reasons. These are the increased generation of waste due to increased population, improved living standards, technical and human capacity limitations (Guerrero et al. 2013). African countries are now faced with huge amounts of municipal waste, which has a direct effect on human health, safety, and environment (Bello et al. 2016). Although there is a paucity of data on waste generated annually in Nigeria, however, Isiaka (2017) reports that about 3 two million tons of waste are generated annually, while Vanguard (2017) reports a value of 24 million tons. Of these, only about 20–30% is collected with vegetal wastes, making up 65% of those collected (Isiaka 2017; Ogwueleka 2009).

Vegetal matter refers to substances produced by plant or growing in the manner of plant that can be decomposed by microorganisms. Significant contribution to greenhouse gases and volatile organic compounds emissions comes from their high moisture, organic contents, and biodegradability (Sridevi and Ramanujam 2012). Nonetheless, converting this resource properly could contribute to sustainable energy provision, which Nigeria is in dire need of. Anaerobic digestion is a technology that is recognized to be useful for converting vegetal and animal wastes to generate renewable energy in the form of biogas and organic fertilizer (Arsova 2010). This could result in saving the environment from further degradation, supplementing the energy needs of the rural population (Ahmadu et al. 2009), and generate extra returns streams for farmers and investors (Twidell and Weir 2005; Aransiola et al. 2014; Budzianowski and Brodacka 2017). This contributes significantly to the circular economy in rural communities (Jun and Xiang 2011). Vegetal matters usually occur in large quantities, making it difficult to dispose of easily; over time, this tend to make them become a source of harmful and offensive substances in landfills due to their decomposing qualities (Misi and Forster 2002).

The deployment of a co-digested anaerobic process using cow rumen as inoculum as local action for climate change impact reduction is reported. Essentially, the study involves the design and fabrication of stainless steel farm tanks for anaerobic bio-digestion; upscale of laboratory experimental data for feedstock loading to produce biogas from the substrate; estimate of avoided emissions compared to other fuel sources for cooking energy; evaluate life cycle costs and return streams of biogas produced based on different scenarios; and formulate a business model.

---

## Literature Review

In biogas production, specificity of the substrate collected usually has effects on the type of digester to be used (Christy et al. 2013). Furthermore, biodigester systems are classified based on the method of feeding and number of reactors, with the method of feeding being either batch or continuous, while the number of reactors could also either be a single stage or multi stage (Brown 2006).

The single-stage process involves three stages of the anaerobic process occurring in one reactor. In this process, fermentative bacteria rate of growth is faster than that of acetogenic and methanogenic bacteria (Brown 2006). The consequence is that it results in acid accumulation, pH falling, and methanogenic bacteria growth. For the multi-stage processes, two or more reactors are used to space out the acetogenesis and methanogenesis stages that serve as filters in the system and thus enhancing the digester's production efficiency (Manyi-Loh et al. 2013).

During batch experimental setup, feeding of the digester is only done once, which is at the beginning of the reaction, with the products of the digester being collected at the end of each cycle. However, in that of the continuous system, the feeding and discharging of organic material is continuous (Levenspiel 1999). Rajendran et al. (2012) reviewed different household digesters which are commonly used, reporting that fixed dome (cylindrical digesters) are most commonly used type of digester in

China, while the floating drum digesters are those highly recognized in India, with other digester types used being majorly tubular such as portable plug flow digesters. In terms of features, fixed dome digesters made up of the feed and digestate pipes, a fermentation chamber and a fixed dome on top of the biogas storage, while floating drum digesters are recognized for the floating drum to be at the top of the digestion chamber which separates the gas production and discharge (Neba et al. 2020). Plug flow digesters, which can operate as a household or an industrial digester, have a simple flow pattern without back-mixing. The presence of serious floating tendencies may cause clogging of the flow and prevent the escape of produced biogas in plug flow digesters, though, an inclined plug flow digester at an angle  $45^\circ$  is a better option (Ziyan and Xiaohua 2014; Rajendran et al. 2012). A major advantage the plug flow digester has over fixed dome and floating drum digesters is that there is no difficulty in moving an installed digester, as it is able to produce biogas at a variable pressure and constant volume. In addition, plug flow digesters are capable of managing waste with the range of 11–13% solid concentration (11–13%) (Roos et al. 2004), being always operated in the mesophilic temperature range (Krich et al. 2005).

Global climate change impact is predicted to affect energy sector as with other key sectors of the economy (Arent et al. 2015). One of the strategic approaches to addressing the future of climate change impact is the use of low-carbon energy sources (Yadoo and Cruickshank 2012). Renewables have been taunted as a major contributor to this strategy (Solaun and Cerdá 2019). Developing countries like Nigeria are quite vulnerable to climate change impact, with energy sector being one of the most vulnerable (Ogundipe et al. 2014). Schaeffer et al. (2012) did an extensive review of the vulnerability of the energy sector to climate change. The paper reported on the vulnerability of biofuels to climate change. In addition, as regards biogas production in rural setting, there are ranges of challenges to be considered, which are well documented in literature (Madriz-Vargas et al. 2018). These challenges can affect the operational outcome of renewable energy (RE) technologies as well as the sustainability of the project as a whole. These issues raise questions as regards the set of community capabilities required, appropriate project design, and enabling an external environment for sustainable community RE (CRE) projects.

To introduce the use of biogas as a low carbon strategy to energy generation in the rural areas, the use of user-centered design concept (Redström 2006) is introduced. This approach was proposed as a means to scale-up the process of developing biodigesters in rural areas for energy generation. The essence of the concept is that it takes user experiences into consideration (Redström 2006) in its design. Thus, the basic concept of the business model formulation of the RE power system is to make it be owned, operated, or maintained by a community organization. With this, technical and nontechnical problems such as the issue of social integration of RE technologies, lack of investment and maintenance capabilities, as well as end-user education (Madriz-Vargas et al. 2018; Margolis and Zuboy 2006) are eliminated.

## Methodology

This section describes the approach adopted to design and fabricate the digesters, upscaling the substrate used to feed the digesters from a laboratory experiments (Adepoju 2019) conducted. The scaling up includes technical design and development of the biodigester, up-scaling biogas production from laboratory experiment, evaluation of avoided emissions, estimation of life cycle costs as well as return streams, and business model formulation.

## Digester Design and Development

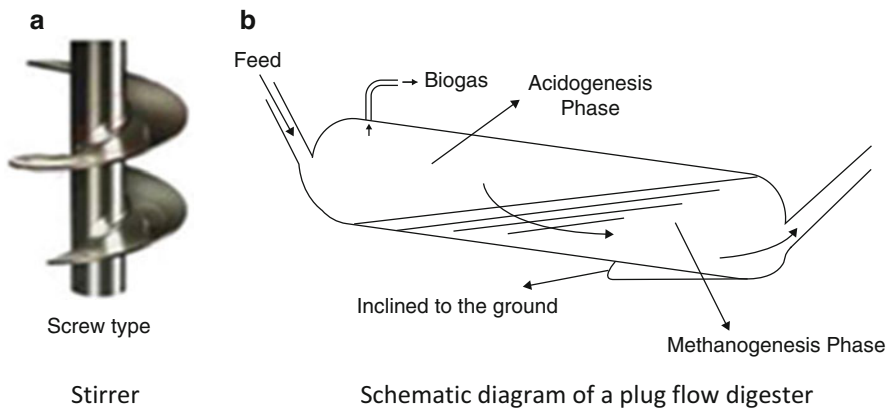
In the design, fabrication, and construction of the plug flow biodigester, the factors that affect the building of digester for optimum biogas yield (Jiang et al. 2011) should be taken into consideration. The principal materials to be selected for the fabrication will be stainless steel sheets because of its durability and as well as its ability to absorb heat easily, which improves mesophilic anaerobic digestion as to when compared to cement and block. The design analysis includes the design specification of the biodigester and the length of the digester is 5.96 m. The required length-to-width will be within the ratio of 3.5:1 based on the Natural Resources Conservation Service (2004) length-to-width ratio for manure in plug-flow digesters. Therefore, the dimensions of the digester are:

Length of the digester (L) = 5.96 m

Width of the digester (W) = 0.71604 m

The volume of the digester = 9.6 m<sup>3</sup>

A plug flow reactor has the following components as shown in Fig. 1:



**Fig. 1** Schematic diagram of a plug flow digester

**Table 1** Theoretical comparison of different substrates to meet energy needs of 100 households

Substrates	Biogas potential (L/kg) <sup>a</sup>	Expected daily biogas production needed for 100 households (m <sup>3</sup> )	Expected biomass (waste) for feeding (tonnes)	Expected size of biodigester (m <sup>3</sup> )
Vegetal matter	70	39.13	133.91	67
Corn silage	200	39.13	465.83	23
Grass silage	220	39.13	423.48	21

<sup>a</sup>Source: Arora and Linton (2011)

1. Inlet and outlet pipes: The inlet pipe can also be referred to as the feed pipe while the outlet pipe as the digestate pipe. The pipes to be used will be of a steel rod with diameters of 500 cm and 250 cm as the inlet for feeding the substrate into the digester and outlet pipes for discharging the consumed slurry at the end of the digestion, respectively. The inlet pipe which will be at an angle of 45° for convenient channel of the substrate into the digester and the entry will be closed to prevent air from getting to the residue for easy break down of waste materials in the digester.
2. Stirrer: A screw-type, stainless material stirrer is shown in Fig. 1. The stirrer will be connected to a motor to drive it in order to create a turbulent motion of the substrates.
3. Storage tank: The storage tanks will be balloons made from high density polyethylene (HDP) or floating tank made from fiber glass for collection of biogas produced.
4. Effluent collection tank: The effluent (digestate) will be collected in a plastic tank.

The design involves the construction of seven 9.6 m<sup>3</sup> biodigesters. A combination of the seven farm tanks biodigesters was designed to produce approximately 39.13 m<sup>3</sup> of biogas daily. It is also expected that for each biodigester, about 64% of the biodigester size would be for gas accumulation. Table 1 shows different substrates with their biogas potentials, expected daily biogas production needed for 100 households, expected biomass feedstock, and expected size of biodigester. The use of grass silage as substrate for biogas production required the least sized digester at 21 m<sup>3</sup>.

## Up-Scaling Biogas Production from Laboratory Experiment

This section describes up-scaling the steps to the pilot scale from laboratory experiment. The laboratory experiment involves the use of portable 20 l plastic containers, modified as digesters, as shown in Fig. 2. Gas collection was done through water displacement method (Otun et al. 2015). Stirring was done by shaking the biodigester to prevent thickening and settling of the slurry. The experiment consists of the use of fresh waste samples of vegetables and fruits serving as feedstocks, and

**Fig. 2** Laboratory-scale experiment (Adepoju 2019)



cow rumen fluid used as inoculum, collected from a food market and an abattoir. The vegetables and fruits, made up of watermelon, tomatoes, and oranges, were grinded to increase the surface area. The cow rumen fluid collected in polyethylene bags was stored at room temperature for 4 days (Elhasan et al. 2015). These were mixed with water to form slurry in the biodigester (Budiyono et al. 2014). Fresh vegetal wastes (V) mixed with cow rumen fluid (R) and clean water (W) in different V:W:R ratio and batch fed into the digester. The retention time was 30 days.

The biodigester was scaled up based on the data acquired from the laboratory-scale experiment to meet the energy needs of about a hundred (100) rural households. The energy cooking need was estimated based on Riuji (2005) and Rea (2014) that 100 l of biogas will produce 23 min of cooking time. It was assumed that a household of 5 will use 390 l of biogas for 90 min cooking time in a day. With these data, it was estimated that 100 households will require 39,130 l of biogas daily. According to Arora and Linton (2011), 1 kg of vegetal waste will produce on average 2.33 l of biogas daily and a total of 70 l biogas over a retention time of 30 days. From Arora (2011), to achieve a daily production rate of 39,130 l of biogas, will require 16,670 kg of vegetal waste without the use of inoculum, requiring an organic loading rate (OLR) of 555.67 kg daily. With the use of cow rumen as inoculum, the efficiency of the substrate is improved by 26% (Stan et al. 2018), reducing the amount of vegetal matter needed to 13,310 kg or an OLR of 443.67 kg daily. The size of the biodigester is dependent on the amount of waste needed. Using the laboratory experiment that requires 4 kg of waste for 0.02 m<sup>3</sup> of biodigester, the equivalent biodigester size for 13,310 kg of waste was estimated to be 67 m<sup>3</sup> to produce 39,130 l of biogas daily to meet the energy needs of ~100 rural households.



## Avoided Emission Calculations/Climate Change Impact Reduction

The avoided emissions were estimated based on the biogas equivalent to the fossil fuel conversion method (B-Sustain 2013b), and 1 m<sup>3</sup> of biogas equivalent for each of the fuels is given in Table 2. The emission factors of biogas, kerosene, LPG, kerosene, and firewood were obtained from Simon et al. (2006), which was used for the estimation of the CO<sub>2</sub> emission. The CO<sub>2</sub> emission reduction potential of using biogas in relation to other fuels was evaluated by subtracting the emission from the particular fuel and that from biogas.

## Estimation of Life Cycle Costs and Return Streams

In order to estimate the unit cost for the produced biogas for either cooking or electricity generation will involve life cycle analysis (Lakhani et al. 2014). For this project, a 20-year life cycle was assumed for biogas generation (Tsaganakis and Papadogiannis 2006). Based on the assumption, this life cycle cost was calculated thus:

$$\text{Life cycle cost (LCC)} = \frac{\text{Total cost}}{\text{Energy derived}}$$

where Total Cost = Fixed Costs + Variable Costs.

- Cooking:** To calculate LCC for energy derived from biogas for cooking, the assumption made is that the digester has a life cycle of 20 years and production capability of 39.13 m<sup>3</sup> per day. It is also assumed that the digester will work for 300 days in a year.
- Electricity generation:** For the energy derived from biogas for electricity, the assumption made for the life cycle is 20 years, production capacity of 849845.57 BTU/day, and 300 days of yearly operation.
- Digestate production:** To calculate LCC for digestate from the biodigester, the assumption made is that the digester has a life cycle of 20 years and production capability of 54.26 kg per day, with 300 working days per year.

**Table 2** Biogas equivalent to fossil fuels and firewood

	Fuel	Quantity (kg)
	LPG	0.45
	Kerosene	0.6
1 m <sup>3</sup> of biogas equivalent to	Firewood	3.5
	Furnace oil	0.4
	Petrol	0.7
	Diesel	0.5

Source: B-Sustain (2013b)

The life cycle costs obtained were used to calculate the sales price based on the value added tax (VAT) of 5%, bank interest of 25% (assuming bank loan was secured to execute the project), sales tax of 5% (assuming sales tax will be charged), and a profit margin of 5%, which gives a sum of 40%. The sales prices were estimated by calculating 40% of the life cycle costs.

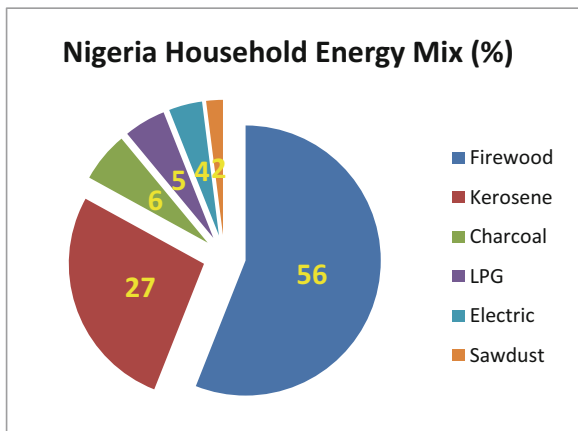
## Business Model Formulation

The user-centered approach represents the concept behind the business model formulation to enable coupling of technical and economic aspects of biogas production principally for rural energy supply. This also includes issues of cash flows, access to finances, and fuel switching in rural areas of Nigeria.

The formulated business model gives potential investors an overview of typical rural energy markets, target customers, and potential return streams to be earned from a biogas production business. The adapted model is an integrated one with three domains. The first domain is the upstream side or technical input, which includes planning, R&D resources, and installation of the production process of the business that includes building of the biodigester, storage system, laying of supply pipelines, and sourcing for raw materials to be used from farms and food industries biowastes. The second domain reflects the transformation of the raw materials from the biodigester to create value for the target market. This involves anaerobic digestion to yield raw biogas and the byproduct as digestate (fertilizer), piping the biogas to connected households for cooking, and subsequently cleaning and pressurizing the biogas for electricity generation to the target customers. The last domain is the market segment of the business. This involves the marketing of biogas and digestate to target customers which include: cottage industries, residential use, commercial, and farmers.

Smallholders in rural areas usually have limited access to finance as they have to confront different challenges from bank demands, such as the complex and drawn-out procedure of documentations, high bank charges, short-term nature of the credit, and disturbing problem of mortgage for security (Abdullah et al. 2015). In the same vein is the issue of fuel switching. The Nigeria household energy mix is as shown in Fig. 3, with firewood making up 56% and sawdust being the least at 2%. To increase the proportion of clean energy sources in the form of gas such as LPG and biogas will require substantial fuel switching. The current proportion of clean energy sources in the household energy mix is barely 5%. This will even be worse in rural areas in Nigeria, where dependence on unclean sources such as firewood and kerosene are even more prevalent. For clean energy sources such as biogas or LPG to be more acceptable, the proposed business model takes into consideration the provision for household fuel switch, particularly in rural areas. The most used fuel stove currently in rural areas of Nigeria is based on firewood that depends on the traditional three-stone stoves or mud-built stoves. These stoves are grossly inefficient and unhealthy for humans and the environment due to the release of inimical particulate matter into the air (Akinbami and Momodu 2013). So tackling fuel

**Fig. 3** Nigeria household energy mix (Source: Ministry of Petroleum Resources 2017)



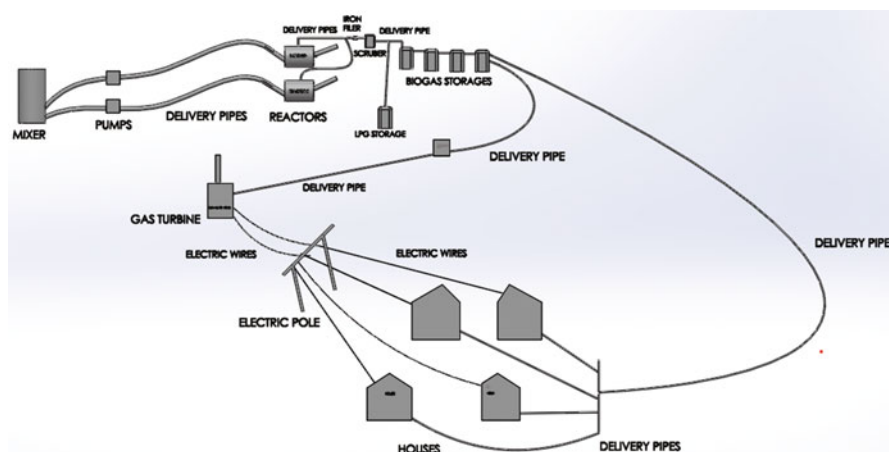
switching for rural households will involve tackling the economics of fuel and stove type, respectively. Other issues to be addressed include but not limited to access conditions to fuels, technical characteristics of cook stoves and cooking practices, cultural preferences, and health impacts (Masera et al. 2000).

## Results and Discussion

This section presents the results and analysis of the study. This includes the process of scaling up laboratory experiments to the field scale, avoided emission, investment cost, variable cost stream, lifecycle cost, and return streams, as well as business model formulation.

### Scaled Up Biogas Production

Scaling up the biogas production to meet energy provision consists of a system of seven tanks of biodigesters that are each sized at 9.6 m<sup>3</sup>. In this farm of biodigesters, the tanks tilted at 45° will consist of a mechanical stirrer, inlet, and outlet for feeding slurry and evacuating digestate, respectively. Biogas collection will be done using gas hoses connected to the gate valve at the top of the biodigester tanks (Arnott 1985). The raw biogas will be subjected to purification, liquefaction, storage, and transportation (Ahmad et al. 2018). The purification could be done either using water scrubber and iron filings or through cryogenic processes, depending on the level of purity required, which is determined by use. The water scrubber and iron filings will be used to clean the biogas by removing CO<sub>2</sub> and H<sub>2</sub>S when the gas is needed only for cooking. On the other hand, cryogenic process is used when the gas purity is required at 94–99% level. This is an environmentally friendly biogas upgrading and



**Fig. 4** Schematic layout of biogas production system for household energy and electricity generation

biomethane liquefaction system which separates pollutants and  $\text{CO}_2$  from biogas via low-temperature (Ahmad et al. 2018). The cryogenic process will be used to purify and liquefy the biogas to be produced for the reason of storage, transportation, and high energy content gas demand of some applications. Thus, it is imperative that the concentration of methane in the biogas be increased with the removal of  $\text{CO}_2$ .

The gas will be stored in four interconnected fiber-glass tanks of  $10 \text{ m}^3$  each. Two fiber glass tanks will supply gas for electricity generation, while the other two fiber glass tanks will be for cooking. For safety measures, there will be an inclusion of a water-cooling system for the storage tanks and regular cleaning of the pipe holes to avoid blockages and leakages and the use of several pressure relief valves along the pipeline to control the pressure of the gas. A schematic of the biogas production system is depicted in Fig. 4.

## Avoided Emissions

Utilization of energy derived from biogas technology operates to reduce GHG emissions, particularly  $\text{CO}_2$ , by reducing the demand for fossil fuels and waste management (B-Sustain 2013a). The emission factors used for estimating the GHG emission from different fuel types are shown in Table 3, while Table 4 shows the total GHG emission of different fuel types. Table 5 shows that using  $39.13 \text{ m}^3/\text{day}$  of biogas produced from vegetal matter could reduce the  $\text{CO}_2$  emission of  $9.69 \text{ kg}$  from LPG,  $37.49 \text{ kg}$  from kerosene,  $23.15 \text{ kg}$  from diesel, and  $181.65 \text{ kg}$  from firewood use. Therefore, using biogas produced from waste of vegetal matter instead of LPG, kerosene, diesel, and firewood fuels is a means to mitigate the environmental impacts of  $\text{CO}_2$  and other GHG.

**Table 3** Emission factors

Emission factors	Fuel type				
	Biogas	LPG	Kerosene	Diesel	Firewood
CO <sub>2</sub> (kg/MJ)	0.055	0.063	0.072	0.074	0.11
CH <sub>4</sub> (kg/MJ)	0.000001	0.000001	0.000003	0.000003	0.00003

Source: (IPCC 2006)

**Table 4** Emissions from different fuel types

Fuel type	Gas emitted (Kg)					
	Daily		Annually		For a period of 20 years	
	CO <sub>2</sub>	CH <sub>4</sub>	CO <sub>2</sub>	CH <sub>4</sub>	CO <sub>2</sub>	CH <sub>4</sub>
<b>Biogas</b>	40.6	0.00074	12,178.1	0.22	243,560.8	4.5
<b>LPG</b>	50.3	0.00079	15,086.5	0.24	301,729.3	4.8
<b>Kerosene</b>	78.1	0.0032	23,424.2	0.98	468,484.6	19.6
<b>Diesel</b>	63.7	0.0026	19,122.3	0.77	382,444.9	15.5
<b>Firewood</b>	222.2	0.06	66,673.2	17.86	1,333,466	357.2

**Table 5** Avoided emissions from different fuel types

Fuel Type	Gas emitted (Kg)					
	Daily		Annually		For a period of 20 years	
	CO <sub>2</sub>	CH <sub>4</sub>	CO <sub>2</sub>	CH <sub>4</sub>	CO <sub>2</sub>	CH <sub>4</sub>
<b>Biogas</b>	0	0	0	0	0	0
<b>LPG</b>	9.7	5.3E-05	2908.4	0.016	58,168.55	0.3
<b>Kerosene</b>	37.5	0.0025	11,246.2	0.76	224,923.8	15.1
<b>Diesel</b>	23.2	0.0018	6944.2	0.55	138,884.1	11.0
<b>Firewood</b>	181.7	0.059	54,495.3	17.62	1,089,906	352.7

## Investment Cost and Variable Cost Stream

The cost stream, as shown in Table 6, itemizes the cost of materials to be used for the construction of 67 m<sup>3</sup> biogas digester, including its civil works, the pipelines for gas evacuation and distribution, and the storage tank. The materials include stainless steel, copper pipes for connections, different sizes of valves, scrubber and iron filings, compressor, LPG cylinder, gas turbine, storage tanks, single burner cooking stoves, and rubber hoses. For purer gas needs, the materials will include cryogenic equipment.

## Life Cycle Costs and Return Streams

Based on the production of biogas from the biogas digesters, life cycle costs (LCC) were estimated for cooking, electricity generation, and digestate production in three different scenarios. The first scenario, called A, considered the production of

**Table 6** Cost stream

Item description	Estimated unit cost	Estimated quantity	Amount (₦)
<b>Fixed costs</b>			
Stainless steel 9.6 m <sup>3</sup> tanks	1000,000	7	7,000,000
Different sizes of connecting tubes	500	160	80,000
Different sizes of valves	5000	160	800,000
Cryogenic equipment	3,500,000	2	7,000,000
Land cost and site construction	1,500,000	4	6,000,000
Transportation	2,000	12	24,000
Storage tanks	200,000	18	3,600,000
Average labor (skilled and unskilled) costs	8,000	20	160,000
Purchase of pressure relief valves	1,000	10	10,000
Purchase of copper pipes	6,000	2	12,000
Construction of biogas burner cooking stoves	8,000	100	800,000
Gas distribution lines	1000	500	500,000
			<b>25,986,000</b>
<b>Variable cost</b>			
Substrate collection	399,286	1	399,286
Sample analysis	8000	1	8,000
Operation and maintenance costs	2,000,000	1	2,000,000
<b>Salvage cost</b>	700,000	1	700,000
<b>Total</b>			<b>29,093,285.60</b>

digestate and biogas for cooking only, in which the LCC are \$0.13/kg (₦ 44.67/kg) and \$0.14/m<sup>3</sup> (₦50.50/m<sup>3</sup>), respectively. The second scenario B is the production of the digestate and biogas for electricity, while the last scenario C considers the production of digestate, 50% biogas for cooking and 50% biogas for electricity. These life cycle costs enable the cost comparison analysis of various scenarios (Table 7).

Theoretically, the investment cost is estimated as ₦29.1 million, while the return streams at different scenarios are the same, which is ₦ 40.74 million with a profit margin of ₦ 11.74 million and an average annual profit of ₦0.59 million. With the positive difference between the LCC and the return stream generated, the biogas project shows good performance with hope the business will allow for its smooth operation to enable quick cost recovery.

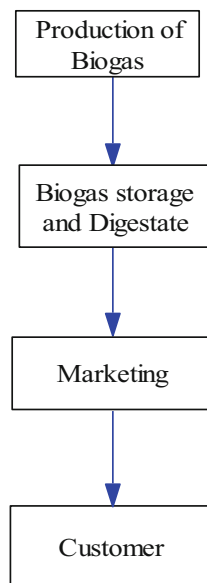
## Business Model Formulation

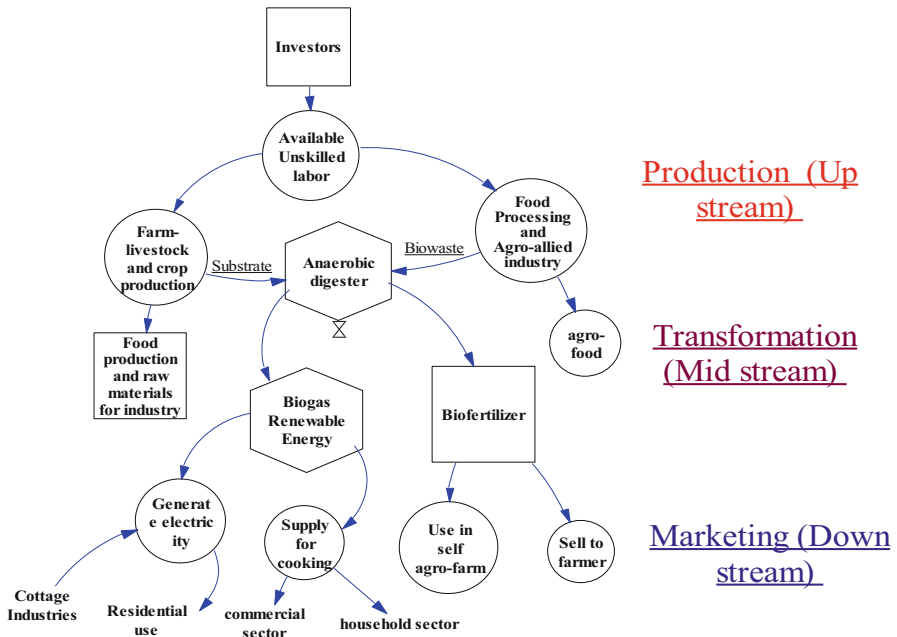
The concept proposed for the rural energy biogas business, based on user-centered design, is diagrammatically shown in both Figs. 5 and 6, respectively. Figure 5 shows a simplified schematic diagram of the business model that mimics what is

**Table 7** LCC and return stream

Scenario A				
	LCC (₦/kg)	Sales price (₦/ kg)	Quantity (tonnes)	Revenue (₦) (million)
Cooking	50.50	70.69	288.1	20.37
Digestate	44.67	62.54	325.6	20.37
<b>Total</b>				<b>40.74</b>
Scenario B				
	LCC	Sales price	Quantity	Revenue (₦) (million)
Electricity generation	0.00285 (₦/ BTU)	0.004 (₦/BTU)	5 million BTU	20.37
Digestate	44.67 (₦/kg)	62.54 (₦/kg)	325.6 tonnes	20.37
<b>Total</b>				<b>40.74</b>
Scenario C				
	LCC	Sales price (₦)	Quantity	Revenue (₦) (million)
Cooking	₦ 67.33/kg	94.25	144.04 tonnes	13.58
Electricity generation	₦ 0.0038/ BTU	0.0053	2 million BTU	13.58
Digestate	₦ 29.79/kg	41.70	325.6 tonnes	13.58
<b>Total</b>				<b>40.74</b>

**Fig. 5** Simplified schematic diagram of the biogas business model





**Fig. 6** Schematic diagram of the adopted business model. Source: Adapted from Yousuf et al. (2017)

obtained in traditional vertically integrated electric power systems (Walsh and Todeva 2005). Both diagrams show three distinct operations of technical inputs, storage of biogas and digestate, as well as marketing. The first domain contains most of the investment cost segment of the model. The cost stream in the business model involves investment in livestock and crop farming, food processing, agro-allied industry, and biodigester construction, while the biogas yield and bio-fertilizer will generate the return stream for the business. From the perspective of the investors, the financial feasibility of the biogas business would be assessed based on its return and cost streams as well as its ability to make profit. In Nigeria, rural areas are mostly faced with challenges in fuel switching, access to finances, and cash flows. For this project, in order to make the business model operational, the issue of fuel switching is addressed. Addressing this challenge involves adopting a user-centered approach that combines different types of business models. At inception, a niche business model would be introduced to incentivize the first few households that adopt (early adopters) the use of biogas as an energy source, where a single gas stove burner would be given to them free but have to buy the gas to be used. For other households (mid to late adopters), the razor and blade business model would be introduced, where the users will have to buy the gas stoves at graduated subsidized prices and still also have to purchase the gas for use.



## Conclusions and Recommendations

Global climate change impact needs to be addressed strategically using local actions. One of such strategy is the use of low-carbon energy resource to meet energy demand. Energy supply in Nigeria is at best erratic, and this is even more pronounced in the rural areas. In addition, Nigeria, particularly her rural populace, is among the most vulnerable to global climate change impact; this is even more aggravated by Nigeria's dependence on fossil fuel usage as well as poor waste management, which two, contribute significantly to greenhouse gas emissions and influences climate change impact significantly. Using waste conversion option through biogas production to meet rural household energy demand is a local action to contribute to the global strategy. Presented are both technical and business model for using biogas production as a means of waste management measure and energy supply source. The study shows that, theoretically, scaling up of laboratory experiments for biogas production through the process of bio-waste anaerobic digestion is not only possible but also comes with a positive difference in climate change impact reduction as well as between costs and returns. First, the project will achieve avoided emissions to reduce climate change impact, which is put at 58,168.55 kg, 224,923.8 kg, 138,884.1 kg, and 1,089,906 kg, respectively, for LPG, kerosene, diesel, and firewood. In terms of costs and returns, three different scenarios are looked into, namely, Scenario A involves just cooking using the biogas produced for cooking and selling of the digestate as bio-fertilizer; Scenario B, involving using the biogas produced for electricity generation, and selling of the digestate; and Scenario C, cooking, electricity generation, and digestate sales are considered. The total cost estimated for starting the project is approximately ₦29.1 million, and the returns stream is estimated at ₦40.74 million. This gives a profit margin of ₦11.64 million for the 20-year life cycle and an average yearly profit of ₦0.59 million. It is important to note that each of the scenarios presented the same total cost though the LCC and sales price pathways were different. Biogas energy production could be effective to transforming the rural economy. Another aspect of interest that needs to be further investigated is that the CO<sub>2</sub> got from cryogenic processes could be channeled. This will generate some income while also removing CO<sub>2</sub> from the atmosphere. It is further recommended that an actual pilot scale be done with data to verify the theoretical estimation made in this study.

---

## References

- Abdullah DZ, Khan SA, Jebran K, Ali A (2015) Agricultural credit in Pakistan: past trends and future prospects. *J Appl Environ Biol Sci* 5:178–188
- Adepoju TD (2019) Biogas generation using vegetal matter via anaerobic digester. A Bachelor's degree thesis. Obafemi Awolowo University, Ile-Ife
- Ahmad NE, Mel M, Sinaga N (2018) Design of liquefaction process of biogas using Aspen HYSYS simulation. *J Adv Res Biofuel Bioenergy* 2:10–15
- Ahmadu TO, Folayan CO, Yawas DS (2009) Comparative performance of cow dung and chicken droppings for biogas production. *Niger J Eng* 16(1):154–164

- Akinbami CA, Momodu AS (2013) Health and environmental implications of rural female entrepreneurship practices in Osun state Nigeria. *Ambio* 42(5):644–657
- Aransiola EF, Ojumu TV, Oyekola OO, Madzimbamuto TF, Ikhu-Omoregbe DIO (2014) A review of current technology for biodiesel production: state of the art. *Biomass Bioenergy* 61:276–297
- Arent DJ, Tol RS, Faust E, Hella JP, Kumar S, Strzepek KM, Tóth FL, Yan D, Abdulla A, Khesghi H, Xu H (2015) Key economic sectors and services. In: *Climate change 2014 impacts, adaptation and vulnerability: part a: global and sectoral aspects*. Cambridge University Press, Cambridge, pp 659–708. 2010
- Arnott M (1985) *Biogas/biofertilizer business handbook* (no. PB-87-158937/XAB; PC/ICE/R-48). Peace Corps, Washington, DC. Information Collection and Exchange
- Arora SM, Linton JA (2011) Mississippi renewable energy and energy efficiency report. A snapshot of related activities in the state of Mississippi (no. DOE-MTA-85002). Mississippi Technology Alliance, Jackson
- Arsova L (2010) Anaerobic digestion of food waste: current status, problems and an alternative product. Department of Earth and Environmental Engineering Foundation of Engineering and Applied Science Columbia University
- Bello IA, bin Ismail MN, Kabbashi NA (2016) Solid waste management in Africa: a review. *Int J Waste Resour* 6(2):1–4
- Bharadwaj A, Yadav D, Varshney S (2015) Non-biodegradable waste- its impact and safe disposal L. *Int J Adv Technol Eng Sci* III:184–191
- Böyük G, Mert M (2014) Fossil & renewable energy consumption, GHGs (greenhouse gases) and economic growth: evidence from a panel of EU (European Union) countries. *Energy* 74:439–446
- Brown VJ (2006) Biogas a bright idea for Africa. *Environ Health Perspect* 114:A300–A303
- B-Sustain (2013a) Environmental and social benefits of biogas technology. Retrieved from: <http://www.bsustain.in/faqs.html>. Accessed July 2019
- B-Sustain (2013b) Biogas equivalent to fossil fuels and its emission comparison. Retrieved from: <http://www.bsustain.in/faqs.html>. Accessed July 2019
- Budiyono B, Widiyasa IN, Johari S, Sunarso S (2014) Increasing biogas production rate from cattle manure using rumen fluid as inoculums. *Int J Sci Eng* 6(1):31–38
- Budzianowski WM, Brodacka M (2017) Biomethane storage: evaluation of technologies, end uses, business models, and sustainability. *Energy Convers Manag* 141:254–273
- Christy EM, Sampson NM, Edson LM, Anthony IO, Michael S (2013) Microbial anaerobic digestion (bio-digesters) as an approach to the decontamination of animal wastes in pollution control and the generation of renewable energy. *Int J Environ Res Public Health* 10:4390–4417
- Elhasan MMAA, Abdalla IF, Ibrahim AAA (2015) Economics of onion production under cooperative and private schemes in Khartoum North, Sudan (No. 15/05). NAF International Working Paper Series
- Guerrero LA, Maas G, Hogland W (2013) Solid waste management challenges for cities in developing countries. *Waste Manag* 33(1):220–232
- Isiaka T (2017) Challenges of waste management in Lagos. *Susty Vibes*
- Jiang X, Sommer SG, Christensen KV (2011) A review of the biogas industry in China. *Energy Policy* 39(10):6073–6081
- Jun H, Xiang H (2011) Development of circular economy is a fundamental way to achieve agriculture sustainable development in China. *Energy Procedia* 5:1530–1534
- Krich K, Augenstein D, Batmale J, Benemann J, Rutledge B, Salour D (2005) *Biomethane from dairy waste: a sourcebook for the production and use of renewable natural gas in California*. Western United Dairymen. Available at: [http://www.suscon.org/cowpower/biomethaneSourcebook/Full\\_Report.pdf](http://www.suscon.org/cowpower/biomethaneSourcebook/Full_Report.pdf)
- Lakhani R, Doluweira G, Bergerson J (2014) Internalizing land use impacts for life cycle cost analysis of energy systems: a case of Californias photovoltaic implementation. *Appl Energy* 116:253–259
- Levenspiel O (1999) *Chemical reaction engineering*. *Ind Eng Chem Res* 38(11):4140–4143
- Madriz-Vargas R, Bruce A, Watt M (2018) The future of community renewable energy for electricity access in rural Central America. *Energy Res Soc Sci* 35:118–131

- Manyi-Loh CE, Mamphweli SN, Meyer EL, Okoh AI, Makaka G, Simon M (2013) Microbial anaerobic digestion (bio-digesters) as an approach to the decontamination of animal wastes in pollution control and the generation of renewable energy. *Int J Environ Res Public Health* 10(9):4390–4417
- Margolis R, Zuboy J (2006) Nontechnical barriers to solar energy use: review of recent literature (No. NREL/TP-520-40116). National Renewable Energy Laboratory (NREL), Golden
- Masera OR, Saatkamp BD, Kammen DM (2000) From linear fuel switching to multiple cooking strategies: a critique and alternative to the energy ladder model. *World Dev* 28(12):2083–2103
- Ministry of Petroleum Resources (2017) National gas policy approved by FEC. Assessed from <http://www.petroleumindustrybill.com/wpcontent/uploads/2017/06/National-Gas-Policy-Approved-By-FEC-in-June-2017.pdf>. 27 May 2019
- Misi SN, Forster CF (2002) Semi-continuous anaerobic co-digestion of agro-wastes. *Environ Technol* 23(4):445–451
- Natural Resources Conservation Service (2004) Anaerobic digester-controlled temperature. 2004Code366 Natural resources conservation service, Conservation practice standard. Available at <http://efotg.sc.egov.usda.gov/references/public/CA/366std-9-04.pdf>
- Neba FA, Asiedu NY, Addo A, Morken J, Østerhus SW, Seidu R (2020) Biodigester rapid analysis and design system (B-RADeS): a candidate attainable region-based simulator for the synthesis of biogas reactor structures. *Comput Chem Eng* 132:106607
- Ogundipe A, Akinyemi O, Alege PO (2014) Energy supply and climate change in Nigeria. *J Environ Earth Sci* 4:14
- Ogwueleka TC (2009) Municipal solid waste characteristics and Management in Nigeria. *Iran J Environ Health Sci Eng* 6(3):173–180
- Otun T, Ojo O, Ajibade F (2015) Evaluation of biogas production from the digestion and co-digestion of animal waste, food waste and fruit waste. *Int J Energy Environ Res* 3(3):12–24
- Rajendran K, Aslanzadeh S, Taherzadeh JM (2012) Household biogas digesters- a review. *Energies* 5(8):2911–2942
- Rea J (2014) Kinetic modeling and experimentation of anaerobic digestion. Doctoral dissertation, Massachusetts Institute of Technology
- Redström J (2006) Towards user design? On the shift from object to user as the subject of design. *Des Stud* 27(2):123–139
- Riuji LC (2005) Research on anaerobic digestion of organic solid waste at household level in Dar Es Salaam, Tanzania. Doctoral dissertation, ARDHI University
- Roos KF, Martin JB, Moser MA (2004) AgStar handbook: a manual for developing biogas systems at commercial farms in the United States. EPA-430-B-97-015. USEPA, Washington, DC. Available at: <http://www.epa.gov/agstar/documents/AgSTAR-handbook.pdf>
- Schaeffer R, Szklo AS, de Lucena AFP, Borba BSMC, Nogueira LPP, Fleming FP, Troccoli A, Harrison M, Boulahya MS (2012) Energy sector vulnerability to climate change: a review. *Energy* 38(1):1–12
- Simon Eggelston, Leandro Buendia, Kyoko Miwa, Todd Ngara, Kiyoto Tanabe (2006) Guidelines for national greenhouse gas inventories. The Institute for Global Environmental Strategies (IGES) for the IPCC, Tokyo, Japan
- Solaun K, Cerdá E (2019) Climate change impacts on renewable energy generation. A review of quantitative projections. *Renew Sust Energ Rev* 116:109415
- Sridevi D, Ramanujam RA (2012) Biogas generation in a vegetable waste anaerobic digester: an analytical approach. *Res J Recent Sci* 1(3):41–47
- Stan C, Collaguazo G, Streche C, Apostol T, Cocarta D (2018) Pilot-scale anaerobic co-digestion of the OFMSW: improving biogas production and startup. *Sustainability* 10(6):1939
- Tsaganakis KP, Papadogiannis C (2006) Technical and economic evaluation of the biogas utilization for energy production at Iraklio municipality, Greece. *Energy Convers Manag* 47:844–857
- Twidell J, Weir T (2005) Biomass and biofuels. In: *Renewable energy resources*, 2nd edn. Spon, London, pp 351–399

- Vanguard (2017) Nigeria generated 24m tonnes of waste more than rice in 18 states in 2016 – reports. Assessed from <https://www.vanguardngr.com/2017/08/nigeria-generated-24m-tonnes-waste-rice-18-states-2016-reports/>. 16th Aug 2019
- Walsh PR, Todeva E (2005) Vertical and Horizontal Integration in the Utilities Sector: the case of RWE. Unpublished paper
- WHO (2015) Residential heating with wood and coal: health impacts and policy options in Europe and North America. World Health Organisation, Copenhagen, Denmark
- Yadoo A, Cruickshank H (2012) The role for low carbon electrification technologies in poverty reduction and climate change strategies: a focus on renewable energy mini-grids with case studies in Nepal, Peru and Kenya. *Energy Policy* 42:591–602
- Yousuf A, Sultana S, Monir M, Karim A, Rahmaddulla S (2017) Social business models for empowering the biogas technology. *Energy sources. Part B Economics, planning and policy*. 12:99–109
- Ziyan T, Xiaohua L (2014) Design and optimization principles of biogas reactors in large scale applications. In: *Reactor and process design in sustainable energy technology*. Elsevier, Amsterdam, Netherlands, pp 99–134

**Open Access** This chapter is licensed under the terms of the Creative Commons Attribution 4.0 International License (<http://creativecommons.org/licenses/by/4.0/>), which permits use, sharing, adaptation, distribution and reproduction in any medium or format, as long as you give appropriate credit to the original author(s) and the source, provide a link to the Creative Commons license and indicate if changes were made.

The images or other third party material in this chapter are included in the chapter's Creative Commons license, unless indicated otherwise in a credit line to the material. If material is not included in the chapter's Creative Commons license and your intended use is not permitted by statutory regulation or exceeds the permitted use, you will need to obtain permission directly from the copyright holder.





# Biochar for Climate Change Adaptation: Effect on Heavy Metal Composition of *Telfairia occidentalis* Leaves

# 68

Doris Akachukwu, Michael Adedapo Gbadegesin,  
Philippa Chinyere Ojimekwe, and Christopher John Atkinson

## Contents

Introduction .....	1402
Materials and Methods .....	1409
Study Area .....	1409
Sociodemographic Data .....	1410
Biochar Preparation .....	1410
Soil Preparation and Biochar Application .....	1410
Procurement, Cultivation, and Growth Indices of <i>Telfairia occidentalis</i> .....	1410
Heavy Metal Determination .....	1410
Data Analysis .....	1411
Results and Discussion .....	1411
Conclusion .....	1415
References .....	1415

This chapter was previously published non-open access with exclusive rights reserved by the Publisher. It has been changed retrospectively to open access under a CC BY 4.0 license and the copyright holder is “The Author(s)”. For further details, please see the license information at the end of the chapter.

D. Akachukwu (✉)

Department of Agriculture, Health and Environment, Natural Resources Institute, University of Greenwich, Chatham, UK

M. A. Gbadegesin

Department of Biochemistry, Faculty of Basic Medical Sciences, University of Ibadan, Ibadan, Oyo State, Nigeria

P. C. Ojimekwe

Department of Food Science and Technology, Michael Okpara University of Agriculture, Umudike, Abia State, Nigeria

C. J. Atkinson

Natural Resources Institute, University of Greenwich, London, UK

Department of Agriculture, Health and Environment, Natural Resources Institute, University of Greenwich, Chatham, UK

© The Author(s) 2021

W. Leal Filho et al. (eds.), *African Handbook of Climate Change Adaptation*,  
[https://doi.org/10.1007/978-3-030-45106-6\\_202](https://doi.org/10.1007/978-3-030-45106-6_202)

1401

## Abstract

Gas flaring is a key contributor of greenhouse gases that causes global warming and climate change. Adaptation measures for tackling impacts of climate change have gained much research interest. This chapter assessed vegetable farmers' perception of gas flaring and the effect of biochar remediation on the heavy metal composition of cultivated *Telfairia occidentalis*. A gas-flared area, Ohaji/Egbema L.G.A of Imo State, and a non-gas-flared area, Umudike, Ikwuano L.G.A, were selected for this research. Structured questionnaire was used to elicit information from 120 respondents. Soils were collected from the study sites and transported to the greenhouse. Five different rates, 0 t ha<sup>-1</sup>, 7.1 t ha<sup>-1</sup>, 13.9 t ha<sup>-1</sup>, 20.9 t ha<sup>-1</sup>, and 28.0 t ha<sup>-1</sup>, of palm bunch biochar were applied to the soils in plastic buckets. After 2 weeks of mineralization, two viable seeds of *Telfairia occidentalis* were planted in each bucket and watered every other day for 8 weeks. The result revealed that 63% of vegetable farmers were female, while 37% were male in the gas-flared area. A total of 97% of the farmers had knowledge of gas flaring. A total decrease of 55% percent income, 90% yield, and 67% market quality of vegetable farmers was attributed to gas-flared activities. The plant height of cultivated vegetables increased every 2 weeks with greater increase in the test plant. Heavy metal concentration (Pb, and Cr) decreased with increasing biochar rate and was significantly lower for 28.0 t ha<sup>-1</sup>. Biochar can enhance soil fertility and help immobilize heavy metals. The effect of biochar application on the heavy metal composition is dependent on the rate of application. Biochar use could be a cheap adaptation measure in the face of a changing climate.

## Keywords

Biochar · Climate change adaptation · Gas flaring · Heavy metal · *Telfairia occidentalis*

## Introduction

Natural gas is a component of petroleum that is released during crude oil exploitation (Mohammed et al. 2016). This natural gas is usually vented or flared (burnt off) (Mohammed et al. 2016). Venting has to do with a direct release of natural gas into the atmosphere without burning, while gas flaring is the indiscriminate burning of natural gas during crude oil exploitation. This practice is common in most countries of the world especially in developing countries like Nigeria where oil companies fail to acquire the needed infrastructure for trapping, storage, and use of natural gas. Gas venting and flaring are responsible for enormous waste of nonrenewable resource, pollution, and an annual release of greenhouse gases which contributes immensely to global warming and climate change (Ajugwo 2013). In 2017, World Bank Global Gas Flaring Reduction Partnership reported that more than 140 billion cubic meters (bcm) of natural gas was flared. This huge volume of gas can serve as a reliable source of energy for the African continent yearly, but on the contrary, it has remained an

unprecedented source of pollution (Emam 2016; Ismail and Umukoro 2012). As commercial deposits of crude oil was discovered in Nigeria, the nation drifted from agriculture to oil exploitation as its national income base. Oil industry became the nation's gold mine as it accounts for over 80% of her earnings (Ohimain 2013a, b). The oil companies in the Niger Delta region of Nigeria provided more than 80% of funds used for allocating national budget (Ede and Edokpa 2015). Nigeria is ranked one of the ten countries of the world with abundant natural gas reserve (Orlando 2006). It has been ranked the second highest in terms of gas flaring activities and the highest in Africa having a whopping gas reserve of over 180 tcm (trillion cubic meter) that has earned it the seventh largest gas reserve worldwide (Oyedepo 2014; Shaaban and Petintin 2014). World Bank reported that Nigeria flared over 7 (seven) billion cubic meters (bcm) of gas in 2018. Nigeria produces over 2,000 billion standard cubic feet of gas yearly (Nriagu et al. 2008). This volume fluctuates regularly because of incessant unrest from militants, activities of miscreants, vandalization, leakages, and so on. Oil exploitation companies in Nigeria are unable to channel natural gas into gainful use since they consider it cost intensive to procure the facilities needed for gas capture. Gas flaring is therefore employed as a safe means to evacuate any associated natural gas during petroleum exploitation, despite its serious deleterious far reaching environmental effects. Threat of flaring gases is common in oil rigs, crude oil refineries, and plants. In advanced countries like the USA, only 1% of the associated natural gas is flared, while in Nigeria more than 60% natural gas is flared every day. This large volume of flared gas has the potential to generate substantial revenue to the government of Nigeria if properly harnessed for cooking or industrial uses (Agboola et al. 2011). The flared gas could also be used to generate (power) electricity which could end the challenge of inadequate power supply especially now that the nation is experiencing reduced oil revenues as a consequence of global decrease in oil price (Ojide et al. 2012). This will raise more revenue for Nigeria at this time when oil prices are generally low.

Nigeria losses over 1 billion naira revenue through gas flaring (Campbell 2004; Fluenta 2019) that would have contributed immensely to the nation's economy if the gas was properly captured (Buzcu-Guven and Harriss 2012). Between November 2016 and November 2017, Nigeria flared over 300 billion standard cubic feet of gas which was sold at an exchange rate of 360 naira to 1 dollar with a domestic supply rate of 1.50 USD per 1000 standard cubic feet of gas. This suggests that the nation lost a whopping sum of over 160 billion naira which could have improved her economic base (NNPC 2017). Rules and regulations governing gas flaring in Nigeria are not adequately adhered to by oil-producing companies because such laws are weakly enforced and the penalty levied on defaulters is insignificant (N10 per standard cubic feet). Oil companies in Nigeria lack modern infrastructure needed for gas capture (Okorie 2018); they perceive that such equipment is expensive, and hence its use may not be economically viable. Ironically, there has been increased preference and demand for cooking gas over other sources of fuel, yet, the colossal waste of gas flaring is still been practiced. Locally and internationally, efforts are therefore needed to ensure that regulations governing gas flaring are strictly adhered for the good of man and the environment (Otitoloju and Dan-Patrick 2010).

The composition of the flared natural gas determines the type of pollutants emitted (Fawole et al. 2016). Gas flaring emits greenhouse gases that warm the

atmosphere, causing climate change (Ukala 2011); also other precursor gases, volatile organic compounds (VOCs), polyaromatic hydrocarbons (PAH), particulate matter, and black carbon from gas flares often contaminate air, soil, and water (Giwa et al. 2014). More than 200 notable toxins have been reported to emanate from gas flares including hydrogen sulfide, toluene, benzene, sulfur dioxide, nitrogen oxide, xylene, and so on (ICF 2006). Particulate matter and precursor gases are among the most toxic pollutants that affect plants and man (Giwa et al. 2014; Yaduma et al. 2013). It releases over 40 billion kilowatts of heat daily into the atmosphere (Ukala 2011). Other pollutants released during gas flaring are soot, organic carbon, particulate matter (Guttikunda and Calori 2013; Giwa et al. 2014; Zhou et al. 2014), and heavy metals (Kampa and Castanas 2008). One percent of global warming arises from gas flaring which contributes over 300 Mt of CO<sub>2</sub> into the atmosphere (IPCC 2014a; Amaechi and Biose 2016). Though the practice of gas flaring has been significantly reduced in some countries, Nigeria is yet to record a significant decline despite numerous government strategies (Ite and Ibok 2013); hence, its devastating effects are still felt (Giwa et al. 2014; Oyedepo 2014). Nigeria has lost so much money as a result of gas flaring since the commencement of oil exploitation (Odumugbo 2010). Nigeria loses well over 2 billion dollars as a result of gas flaring yearly (Campbell 2004). This income would have contributed positively to the nation's economy if the gas was properly captured (Buzcu-Guven and Harriss 2012). Gas flaring is responsible for loss of energy resources in oil companies. It affects art works, paints, and monuments (Abua and Ashua 2015; Amadi 2014; Anomohanran 2012; Donwa et al. 2015; Iyorakpo and Odibikuma 2015; Nkwocha and Pat-Mbano 2010; Olukoya 2015; Ubani and Onyejekwe 2013). It affects the general well-being of the Niger Delta dwellers, both psychologically and otherwise (Nriagu et al. 2008). Noise from flare stalks could also affect man and other living things residing around the area. This could lead to loss of some important species or even outright extinction. Pollutants emitted from gas flares are more concentrated at locations close to the flare site. Those farther away from flare sites have reduced pollutant concentrations (Ojeh 2012). Though gas-flared effects are majorly felt within 450 m radius of flare stack, factors like stack height, flare velocity, temperature, and wind speed affect its impact (Ojeh 2012). When there are notable variations in wind speed and direction, locations close to flare stack may have less concentration of pollutants, while farther locations may have more. Gases can be flared from either a high or low pressure valve, and this affects the concentration of gas emitted and also the noise generated. Global Emission Inventory stated that flaring releases three times more soot than gasoline-driven vehicles (Weyant et al. 2016). It is responsible for the disorientation of water bodies like seas and oceans, for example, for over 40 years now, the ice level of the arctic sea has significantly diminished (IPCC 2013). This rise in sea level is a consequence of global warming (Bernstein et al. 2007).

The Niger Delta area of Nigeria occupies more than 7% of the nation's total land mass with not less than 20 million inhabitants (Tawari and Abowei 2012). The nation has onshore and offshore natural gas reserves located in nine states, namely, Abia, Akwa Ibom, Bayelsa, Cross River, Delta, Edo, Ondo, Imo, and Rivers. They



comprise a total of 185 local government areas, housing over 800 oil-producing wells and gas operation facilities (Osuji and Onojake 2004). Niger Delta environment is constantly being polluted by activities such as gas flaring, crude oil pollution, pipeline and tanker leakages, and so on (Tawari and Abowei 2012). All these pollutants have over the period altered the ecosystem balance, crop development, and human health. They have also been found to affect microbial activities in the area (Sonibare et al. 2010). A greater percentage of rural dwellers in the Niger Delta engages in different agricultural activities especially fishing and farming as means of livelihood. Unfortunately, gas flaring has negatively affected their survival since it has negatively impacted soil, water, and the environment at large. Gas-flared areas have an elevated ambient temperature as a result of the huge amount of heat (above 45 billion kilowatts) that is released daily from gas-flared points (Aaron 2006). Crops cultivated 2 km away from gas-flared points are usually scorched by the heat emitted from the gas flares (Anomohanran 2012). Particulates from gas flares can spread as far as  $2.61 \times 10^6$  km away from flare points (Ede et al. 2011). A study conducted by Gobo et al. (2009) revealed that these pollutants could trigger onset of eye, skin, and respiratory diseases. Prolonged exposure to gas flares has been reported to negatively affect blood hematological parameters (Adienbo and Nwafor 2010). Ovuakporaye et al. (2012) also reported presence of skin and respiratory diseases in residents of gas-flared areas as a result of long-term inhalation of gas-flared fumes. Gaseous pollutants from gas flares such as nitrogen and sulfur oxides are responsible for acid rain. Acid rain corrodes roofing sheets and walls of buildings. Smog that results from the reaction of nitrogen oxides and hydrocarbons in the presence of UV radiation creates poor visibility (Ana et al. 2009). Other diseases reported to be prevalent in gas-flare areas include respiratory disease, eye and skin disorders, skin cancers (Ana et al. 2009), lung cancer (Ana 2011), and so on. Between 2015 and 1965, a period of 51 years, it was reported that an approximate gas quantity of over 900 bcm and 17 bcm every year with carbon monoxide being the most abundant gas was emitted (Giwa et al. 2019). Elevated levels of deleterious heavy metals have been observed in the air of the Niger Delta area. For instance, Olobaniyi and Efe (2007) reported 0.56 mg/l of lead in the area. Gas flaring has been reported to reduce yield of crops (Dung et al. 2008; Odjugo 2007; Odjugo and Osemwenkhae 2009; Olisemauche and Avwersuoghene 2015), induce soil pollution evidenced by increased PAH deposits in soils (Sojinu et al. 2010), and be responsible for various health defects (Bhatia and Wernham 2009; Ekpoh and Obia 2010). The people of the Niger Delta perceive that gas flaring affects their health status and disturbs ecosystem balance generally (Edino et al. 2009).

Living things rely majorly on plants for their survival. The much needed energy and nutrients required by human body for its biochemical processes can be majorly derived from plants. Herbivorous animals (goat, sheep, grass cutters) and omnivorous animals (rat, squirrel, mice) depend on plants for their survival. Plants also provide shelter in the form of vegetation cover for animals that live on land. Cassava and oil palm are among common plants that are often found near gas stacks. The growth (Ozabor and Obisesan 2015) and yield (Achi 2003) of these crops are often affected by gas flaring. Over 70% of the Niger Delta dwellers are convinced that gas

flaring has negatively affected their agricultural activities (Adewale and Mustapha 2015), hence their income source. Data obtained from a study in an oil community, Ebedei in Delta, has shown that gas flaring is affecting production of tuber crops such as yam, potato, and cassava including plantain and okra as well (Ozabor and Obisesan 2015). Acid rain arising from gas-flared pollutants is poisonous to plants. It could even lead to death of plants and hence loss of vegetation cover (Amadi 2014). This could further expose the soil to erosion. Symptoms expressed by plants when attacked by acid rain include shedding of leaves, yellow leaves, loss of photosynthetic ability, and even early death (Efe 2011). Acid rain has a more deleterious effect on plants and vegetation that are closer to gas-flared system. Efe (2011) documented that acid rain has negative impact on growth and development of common staple food crops and even cash crops such as rubber. The soil has not been spared from the impacts of acid rain as it has led to loss of important nutrients needed for plant survival. Other researchers including Jacobson (1984), Neufeld et al. (1985), and Efe (2010) have all documented the effect of acid rain on different plant species; and water quality (Ogunkoy and Efi 2003; Efe and Mogborukor 2008). Plants are important sources of medicine because they possess phytochemicals and other bioactive compounds that are of great pharmaceutical importance (Epidi et al. 2016a, b). The medicinal potential of a plant is a function of its bioactive composition. In another study, Anacleto et al. (2014) and Ifemeje (2015) reported changes in nutritional and phytochemical content of some common edible vegetables such as fluted pumpkin,  $H_2O$  leaf, scent leaf, and bitter leaf. In a similar study, Ujowundu et al. (2013) reported changes in phytochemical (phytate, tannin, alkaloid, and cyanogenic glycoside), proximate composition (ash, moisture, carbohydrate, and proteins), micronutrients (Ca, Na, Mg, K, and P), and vitamins (A, C, and E) in African breadfruit and Bambara groundnuts cultivated near flare sites. Phytochemical (flavonoid, tannin, alkaloid, saponin) and trace metals (Pb, Fe, Cd, Zn) of fluted pumpkin could be altered by gas flaring. Okeke and Okpala (2014) reported decreased soil nutrient in two gas-flared communities (Eket and Izombe) of the Niger Delta area.

Since the era of industrial revolution, man has been faced with the challenge of handling the problems arising from excessive crude oil exploitation, gas flaring, and climate change. Methane and carbon dioxide are the most notable greenhouse gases that are responsible for global warming and climate change. Methane has been found to be the most toxic greenhouse gas because it has the ability to induce global warming (86 times) more than  $CO_2$  (IPCC 2013). To reverse global warming temperature to below  $2^\circ C$  obtained during the pre-industrialization era by the year 2050, there is need to consciously reduce the volume of crude oil exploited. A certain percentage of fossil fuel, for example, about 50% natural gas with 30% crude and 80% coal, needs to be consciously left unexploited in the earth's crust to avoid undue changes in the earth's environment (McGlade and Ekins 2015; UNFCCC 2015; Zhao and Alexandroff 2019). At the 48th Intergovernmental Panel on Climate Changes conference, following close evaluation of climate change data, scientists came up with a global warming temperature target of  $1.5^\circ C$  by the 2035 (IPCC 2018). It is therefore imperative to seek urgent ways of reducing greenhouse gas

emission as well as seeking other sources of energy for man (Rhodes 2019). The World Bank Global Gas Flaring Reduction Initiative (GGFR 2015) has launched several international and national programs including “Zero Routine Flaring by 2030” Initiative to reduce gas flaring rates. Other bodies that launched campaigns for reduction in gas flaring include the 1992 United Nation Convention on climate change and 1997 Kyoto protocol (Malumfashi 2007). Despite all these strategies, significant changes are yet to be recorded (Elvidge et al. 2009; Fawole et al. 2016), and climatic risk is becoming more pronounced.

Climate change has gained important recognition because of its increased risks and widespread effects. It has become an issue of concern, discussion, and debate in various news media of the world. Its effect on the agricultural sector seems to be at its peak. Farmers are more aware of its existence and risks. It has affected their livelihood and general well-being, thus making adaptation measures very imperative. Climate change is a global environmental threat that consciously or unconsciously affects living and non-living things (Patz et al. 2007). Climate change is an alteration in the state of the climate over a period of 10–30 years or more, depending on man-made activities. The United Nations Framework Convention on Climate Change (UNFCCC) stated that climate change is greatly dependent on human activities that alter the atmospheric equilibrium as well as natural climate change overtime (FAO 2008). Climate change is a global phenomenon that has affected man and his environment (IPCC 2014a, b). Climatic changes manifest in the form of weather variations in temperature and precipitation. Adaptation and mitigation strategies are needed in tackling climate change impacts. Climate adaptation has to do with the capacity to manage variations in climate to minimize possible risks, explore new opportunities, or even both. Most African countries like Nigeria are more susceptible to climate change challenges because they are less aware, suffer more exposure, and have reduced potential for adaptation. Changes in climate are greatly affecting agriculture because it is a substantial source of revenue for the nation. Low level of education, poverty, insufficient infrastructure, and poor planning has contributed to increased exposure to risks in climate. It is therefore said to be involuntary in action and not limited to any particular geographical location. It can increase the virulence of disease-causing organisms (pathogens and pests) and also introduce new alien diseases arising from man-made activities or nature. Climate change could be a short or prolonged change in weather parameters that are already being experienced or forecasted as induced by anthropogenic emissions of noxious gases such as carbon dioxide (Parry et al. 2007). Climate change effects are already being felt globally and even in Africa (Creech et al. 2014). There are variations in climate change impacts from one location to another; for example, in some African countries, there have been cases of increased rainfall pattern and drought (Creech et al. 2014). These variations affect weather forecasting as there are hardly records of regularity in pattern of climatic parameters (Keller 2009). Variations in climatic factors such as increase in temperature and CO<sub>2</sub> affect plant’s nutritional quality and its phyto-chemical composition and invariably the animals that consume such plants. It could also lead to increase incidence and severity of epidemics (EU 2015).

Farmers, their households, and stakeholders in agriculture are at greater risk of climatic change since their activities are rain dependent (Pearce et al. 1996). Agriculture is a major source of employment for Niger Delta dwellers. Adaptation to climatic vulnerability is now a major challenge to farmers, researchers, and policy makers. Most adaptation strategies are geared toward eradication of poverty among households (Mertz et al. 2009). Most farmers are already using their local and traditional practices in trying to adapt to the changes in climate with its associated risks. Climate change adaptation refers to all the steps put in place over many decades to enable a system cope with perceived or actual challenges imposed by climate change (Fankhauser 2017). There is need to put up remediative measures to help recover the ecosystem from prolonged environmental pollution and eradicate associated diseases. To enable residents of Niger Delta remain in their localities and retain their occupation as farmers, it is necessary to seek good and durable adaptation strategies. Many adaptation practices have been employed in most communities. A strategy that will likely be of immense importance is one that will improve the soil productivity of the gas-flared areas. For adaptation to be effective, the reality of climate change impacts must be appreciated (Deressa et al. 2011). The way and manner farmers view climate change determines their approaches toward handling its associated challenges. Their behavioral changes to climate change will influence adaptation options and its effects (Adger et al. 2009). Therefore, a close assessment of farmer's perception of climate risks and their specific adaptation measures will foster better understanding of their local exposure to climate risks, the farmer's adaptive capacity to cope with climate change, as well as to enhance policy formulation to tackle challenges that climate change pose on farmers. Intergovernmental Panel on Climate Change (IPCC) has postulated that the adverse effects of climate change will impact many lives globally in the years to come. Trends in rainfall are expected to drift from normal to abnormal with some areas having less rainfall while others have excess. Maturation time of crops will also be affected by increased temperatures especially in the tropics in the next 10 years. This will ultimately affect global food security and health of man (IPCC 2014a).

As a way to make agricultural activities sustainable in the Niger Delta in the face of climate risks, scientists have attempted different procedures with specific interest in those with little or no side effects to the ecosystem. Biochar is a good example of such material that has been used for soil enrichment with great potentials for soil remediation. Biochar is a biomolecule that is used to amend soils with a view to improving its biological and physical characteristics. It is made by pyrolysis of biomass at temperature range of 204–482 °C in the presence of little or no oxygen (Swanson 2013). Biochar is rich in carbon (Lehmann and Joseph 2009). It has the immense advantage of being of biological origin. Biochar improves soil physical and chemical properties, fertility, and nutrient availability (Houben et al. 2013). It reduces bioavailability of heavy metals to plants and organisms by adsorbing them (Al-Wabel et al. 2014). It also stabilizes carbon in the soil, reduces the carbon dioxide in the atmosphere (Fang et al. 2015), and reduces greenhouse gas emission (Galloway et al. 2008). Its advantage over other sources of carbon is that it keeps

carbon long in the soil (Nguyen et al. 2008). Biochar is more durable and effective compared to other carbon sources; it lasts for up to 10,000 years when applied to soil. Stability of biochar depends on its pyrolysis temperature, source material, and soil type (Lehmann and Joseph 2009). Biochar helps in the breakdown of polyaromatic hydrocarbon and adsorbs heavy metals, making them biologically unavailable (Gorovtsov et al. 2018). When biochar is used as a carbon source in soils, the quantity of greenhouse gases emitted decreases by 12% yearly (Woolf et al. 2010). It is a good remediation material that reduces water loss and improves nutrients of soil (Woolf et al. 2010). Use of biochar for agricultural purposes has proven to be a good climate change adaptation practice in the face of threatening global warming and climate change (Lehmann et al. 2006; Woolf et al. 2010). Biochar use is not only environmentally friendly but also alkalinizes soil (O'Neill et al. 2009) and improves crop growth and development (Graber et al. 2010). Biochar improves soil fertility and has great potential for restructuring the ecosystem. It also increases nutrient bioavailability (Wang et al. 2012), leading to production of healthier crops as well as growth of important microorganisms (Bailey et al. 2011; Smith et al. 2010). It improves soil physicochemical properties like organic carbon, cation exchange capacity, and pH (Lehmann 2007). Under normal conditions, carbon dioxide is released from decaying plant matter and serves to balance the carbon cycle. The mechanism of action of biochar is that it forms a strong bond with carbon making it assume a very stable configuration and hence slows the process of decomposition. Biochar use traps carbon in the soil while hindering its migration into the atmosphere in the form of CO<sub>2</sub>. This is therefore a good adaptation process for farmers in gas flaring areas of the Niger Delta region. This will reduce soil water loss and increase soil carbon concentrations and food security (FAO 2008). Biochar has the ability to adsorb toxins, making it unavailable for plant uptake (Sohi et al. 2009). Akachukwu et al. (2018) reported that biochar application enhanced the mineral content of *Telfairia occidentalis* that was cultivated on gas-flared polluted soil. This chapter compared and evaluated the farmers' perception of gas flaring and effect of biochar on heavy metal composition of *Telfairia occidentalis* leaves cultivated on gas-flared polluted soils and non-gas-flared soils.

---

## Materials and Methods

### Study Area

This research was conducted with soils collected from two locations, gas-flared area in Ohaji/Egbema L.G.A of Imo State (longitude N 05° 33.5' and latitude E 06° 45.2') and non-gas-flared area of Ikwuano L.G.A in Abia state (Longitude N 05° 28.5' and Latitude E 007° 32.5') at a depth of 0–20 cm using a sterile auger. The soil was stored in clean jut bags and transported to the greenhouse of the National Root Crops Research Institute, Umudike, Abia State. All the soil samples were collected in April.

## Sociodemographic Data

Well-structured questionnaires were administered randomly to vegetable farmers in the two study sites to assess their perception of gas flaring and its effects on vegetable cultivation and farmers' livelihood.

## Biochar Preparation

Biochar was prepared from sun-dried palm bunches by pyrolysis at 450 °C in a drum kiln. After cooling, it was milled to finer particles, sieved with a 3 mm<sup>2</sup> mesh, and subsequently stored in a clean dry bag until it was ready for use (Karamesouti and Gasparatos 2008).

## Soil Preparation and Biochar Application

Four kilograms of the soil was weighed into clean plastic container. Biochar was applied to the soils at a rate of 0 t ha<sup>-1</sup>, 7.1 t ha<sup>-1</sup>, 13.9 t ha<sup>-1</sup>, 20.9 t ha<sup>-1</sup>, and 28.0 t ha<sup>-1</sup> in three replicates. The soils and biochar were properly mixed, watered, and allowed to mineralize for 2 weeks.

## Procurement, Cultivation, and Growth Indices of *Telfairia occidentalis*

Mature and viable seeds of *T. occidentalis* were obtained from a local market at Ndoro, Ikwuano L.G.A, Abia state, Nigeria. Two seeds were cultivated per container and watered once every 2 days. The growth parameters were measured at an interval of 2 weeks. Matured leaves were harvested after 8 weeks of germination, and samples were air-dried and used for heavy metal determination. Growth indices were measured at 2 weeks interval for 8 weeks. Plant height was measured with the aid of a ruler. Stem diameter was measured with the aid of a vernier caliper, while number of leaves was gotten by counting.

## Heavy Metal Determination

A quantity of 0.2 mg of leaf sample was weighed into dry digestion tubes. Five milliliters of nitric acid was added, swirled, and allowed to stand overnight. Tubes were placed into a digestion block with the temperature gradually increasing from room temperature to 120 °C over about 2 h with periodical swirling of each tube. Thereafter, the temperature was increased to 180 °C until about 0.5 cm<sup>3</sup> of liquid remained. The digestion tubes were removed from the block and cooled at room temperature. The digest was diluted with ultrapure water, homogenized with a vortex

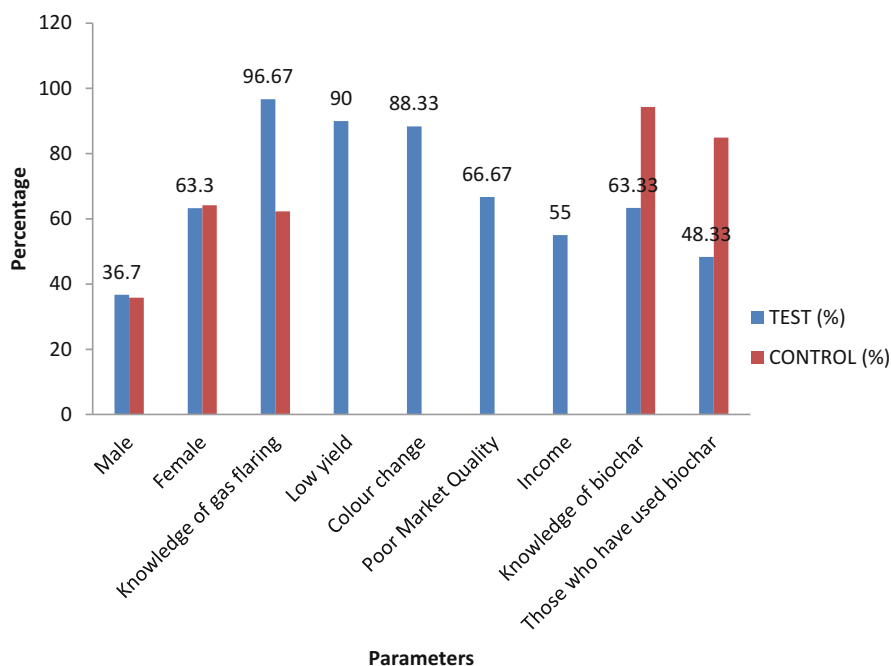
mixer, and allowed to stand for a few hours prior to analysis. The heavy metal concentration was determined using an inductively coupled plasma optical emission spectrometer (ICP-OES) (Optima 8000, Perkin Elmer).

## Data Analysis

The data obtained was analyzed using the Statistical Package for Social Sciences (SPSS) version 21.0 for Windows. Mean comparison was done using one way analysis of variance (ANOVA). Duncan multiple test was used to separate means. Significant values were set at  $p \leq 0.05$ . Data is presented as mean  $\pm$  standard deviation (SD).

## Results and Discussion

Figure 1 shows the result of effect of gas flaring on vegetable cultivation and farmers' livelihood. In all the study sites, more than 60% of vegetable farmers were female while approximately 40% were male. In the gas-flared area (test), almost all the farmers (97%) had knowledge of gas flaring while 62% only knew about gas flaring in the control. This could be because of the absence of gas flaring in



**Fig. 1** Effect of gas flaring on vegetable cultivation and farmers' livelihood

the control area. Also, farmers in the test area had knowledge of biochar (94%) and had also used it (85%) unlike the control area where fewer farmers (63%) knew about biochar and had used it (48%). More than 50% of the farmers from the test area had experienced low yield, color change, poor market quality, and income reduction as a result of gas flaring activities. This could have impacted negatively on the farmers' standard of living, causing discouragement and lack of interest in farming and invariably affect food security. It could also be a subtle cause of youth restiveness that is prevalent in the Niger Delta area. There were no bar charts for control area possibly because of the absence of gas flaring in the control area.

Table 1 shows the growth indices of *T. occidentalis* grown on the gas-flared soil and non-gas-flared soil for 8 weeks. Plant height is an important physiological property useful for assessing the growth and cell differentiation in plants (Silva et al. 2019). It is also an expression of how well a plant is able to optimally utilize soil available nutrients. There was general increase in plant height as the weeks progressed from 2 to 8 weeks for vegetables grown on GFTO and NGFTO, respectively. However, the vegetables grown on the gas-flared soils (GFTO, test) showed higher plant height than those grown on the non-gas-flared soil (NGFTO, control). The 0 t ha<sup>-1</sup> had no evidence of growth after the first 2 weeks. The 7.1 t ha<sup>-1</sup> group had the highest initial plant height (25.77) for the test vegetable, while the 28.0 t ha<sup>-1</sup> group had the highest (25.87) for the control. The pattern of plant height obtained is similar to that of maize plant treated with *Daniella oliviera* wood biochar reported by Aminu and Shamsuddeen (2019). Stem diameter of test vegetables was higher than the control in a non-dose-dependent manner and also reduced with increase in number of weeks in both the test and control vegetables; however, their differences were not statistically different. Dispenza et al. (2016) obtained a dose-dependent increase in stem diameter for substrates of *Euphorbia* treated with 20%, 60%, and 80% conifer wood biochar. Number of leaves increased with increase in weeks (Okonwu and Mensah 2012).

Table 2 presents the heavy concentration of *T. occidentalis* leaves cultivated on biochar-remediated soils from gas-flared and non-gas-flared area. The Fe and Zn concentrations of the gas-flared *T. occidentalis* (GFTO) decreased from 13.9 t ha<sup>-1</sup> to 28.0 t ha<sup>-1</sup> biochar while that of the non-gas-flared *T. occidentalis* (NGFTO) decreased from 0 t ha<sup>-1</sup> to 20.9 t ha<sup>-1</sup> biochar. There was no significant ( $p > 0.05$ ) difference in Fe concentration between the GFTO and NGFTO except for the 13.9 t ha<sup>-1</sup> biochar group that was markedly increased in the GFTO vegetable. No significant difference was observed in Cu concentration for GFTO and NGFTO for all the groups except for the 7.1 t ha<sup>-1</sup>, 13.9 t ha<sup>-1</sup>, and 20.9 t ha<sup>-1</sup> biochar groups that were significantly lower for NGFTO compared to the control. Lead (Pb) and Cr concentrations were significantly ( $p < 0.05$ ) higher for GFTO from 7.1 t ha<sup>-1</sup> biochar, while its concentration decreased from 7.1 t ha<sup>-1</sup> to 20.9 t ha<sup>-1</sup> biochar compared to their control. Cobalt concentration was highest for GFTO treated with 7.1 t ha<sup>-1</sup> biochar while that of 28.0 t ha<sup>-1</sup> GFTO had the least. In the NGFTO, the cobalt concentration decreased from 7.1 t ha<sup>-1</sup> to 20.9 t ha<sup>-1</sup> biochar. Cadmium concentration in both the GFTO and NGFTO decreased with increasing biochar concentration. Nickel concentration was highest in the GFTO-treated with 7.1 t ha<sup>-1</sup>



**Table 1** Effect of biochar remediation on the growth parameters of *T. occidentalis* cultivated on gas-flared and non-gas-flared soils

Parameter	Biochar rate (t ha <sup>-1</sup> )	2 weeks		4 weeks		6 weeks		8 weeks	
		GFTO	NGFTO	GFTO	NGFTO	GFTO	NGFTO	GFTO	NGFTO
<b>Plant height (cm)</b>	0	18.50 ± 6.01 <sup>bc*</sup>	0 <sup>d</sup>	34.57 ± 3.44 <sup>c</sup>	27.97 ± 4.24 <sup>c</sup>	34.5 ± 2.29 <sup>c*</sup>	47.9 ± 4.85	36.63 ± 0.82 <sup>b</sup>	60.77 ± 6.20 <sup>a</sup>
	7.1	25.77 ± 3.39 <sup>a*</sup>	9.67 ± 0.577 <sup>c</sup>	45.4 ± 3.77 <sup>bc*</sup>	25.07 ± 0.81 <sup>c</sup>	62.60 ± 2.59 <sup>a*</sup>	41.17 ± 5.53 <sup>a</sup>	68.4 ± 5.11 <sup>a</sup>	58.50 ± 3.91 <sup>a</sup>
	13.9	22.73 ± 0.92 <sup>ab</sup>	22.00 ± 2.00 <sup>b</sup>	48.97 ± 3.11 <sup>b</sup>	38.00 ± 5.63 <sup>b</sup>	44.07 ± 4.15 <sup>b</sup>	43.57 ± 4.29 <sup>a</sup>	49.35 ± 4.65 <sup>b</sup>	49.17 ± 3.06 <sup>b</sup>
	20.9	22.17 ± 3.18 <sup>ab</sup>	21.3 ± 1.21 <sup>b</sup>	56.97 ± 2.97 <sup>a*</sup>	42.53 ± 2.41 <sup>b</sup>	63.05 ± 1.50 <sup>a*</sup>	50.83 ± 5.97 <sup>a</sup>	68.17 ± 4.16 <sup>a</sup>	57.43 ± 6.19 <sup>a</sup>
<b>Stem diameter (cm)</b>	0	16.00 ± 0.35 <sup>c</sup>	25.87 ± 3.32 <sup>a</sup>	56.03 ± 2.44 <sup>ab</sup>	469.00 ± 1.32 <sup>a</sup>	63.97 ± 5.35 <sup>a</sup>	50.33 ± 6.43 <sup>a</sup>	75.3 ± 15.89 <sup>a</sup>	63.50 ± 1.32 <sup>a</sup>
	7.1	4.81 ± 0.93 <sup>a*</sup>	0 <sup>d</sup>	3.54 ± 0.40 <sup>a</sup>	3.51 ± 0.49 <sup>ab</sup>	3.44 ± 0.86 <sup>a*</sup>	2.79 ± 0.25 <sup>c</sup>	3.06 ± 0.47 <sup>bc*</sup>	2.71 ± 0.19 <sup>a</sup>
	13.9	4.72 ± 0.61 <sup>a*</sup>	3.84 ± 0.035 <sup>c</sup>	3.48 ± 0.22 <sup>a*</sup>	2.64 ± 0.75 <sup>b</sup>	3.18 ± 0.36 <sup>a*</sup>	2.90 ± 0.34 <sup>bc</sup>	3.37 ± 0.42 <sup>bc*</sup>	3.03 ± 0.08 <sup>a</sup>
	20.9	5.13 ± 0.36 <sup>a</sup>	4.63 ± 0.01 <sup>ab</sup>	3.76 ± 0.26 <sup>a*</sup>	2.59 ± 0.69 <sup>b</sup>	3.12 ± 1.17 <sup>a*</sup>	3.64 ± 0.35 <sup>a</sup>	3.28 ± 0.53 <sup>bc*</sup>	3.13 ± 0.54 <sup>a</sup>
<b>Number of leaves (cm)</b>	0	4.75 ± 0.69 <sup>a*</sup>	4.92 ± 0.40 <sup>a</sup>	3.87 ± 0.85 <sup>a*</sup>	4.31 ± 1.09 <sup>a</sup>	4.03 ± 0.91 <sup>a*</sup>	3.43 ± 0.24 <sup>ab</sup>	3.79 ± 1.15 <sup>bc*</sup>	2.99 ± 0.54 <sup>a</sup>
	7.1	4.56 ± 0.63 <sup>a*</sup>	4.19 ± 0.41 <sup>bc</sup>	3.66 ± 0.92 <sup>a*</sup>	3.8 ± 0.55 <sup>ab</sup>	3.63 ± 0.53 <sup>a*</sup>	3.55 ± 0.42 <sup>a</sup>	3.30 ± 0.21 <sup>ab*</sup>	3.60 ± 0.64 <sup>a</sup>
	13.9	4.00 ± 0.00 <sup>a</sup>	0 <sup>d</sup>	5.67 ± 1.53 <sup>b</sup>	5.00 ± 1.73 <sup>b</sup>	7.67 ± 2.08 <sup>a</sup>	8.67 ± 0.58 <sup>bc</sup>	9.67 ± 1.15 <sup>a</sup>	12.00 ± 1.00 <sup>ab</sup>
	20.9	4.00 ± 0.71 <sup>a*</sup>	1.00 ± 0.00 <sup>c</sup>	8.67 ± 2.08 <sup>a</sup>	5.33 ± 1.53 <sup>a</sup>	10.00 ± 2.00 <sup>a</sup>	9.00 ± 1.00 <sup>abc</sup>	10.67 ± 2.89 <sup>a</sup>	10.33 ± 1.16 <sup>ab</sup>
<b>Number of leaves (cm)</b>	7.1	3.00 ± 1.41 <sup>a</sup>	2.67 ± 0.578 <sup>b</sup>	6.00 ± 1.00 <sup>ab</sup>	6.67 ± 1.15 <sup>a</sup>	8.33 ± 2.08 <sup>a</sup>	8.00 ± 1.73 <sup>c</sup>	9.50 ± 1.50 <sup>a</sup>	8.67 ± 2.52 <sup>b</sup>
	20.9	4.00 ± 0.71 <sup>a</sup>	3.67 ± 0.57 <sup>a</sup>	8.33 ± 1.15 <sup>ab</sup>	7.33 ± 1.15 <sup>a</sup>	8.67 ± 2.08 <sup>a</sup>	10.33 ± 0.58 <sup>ab</sup>	12.00 ± 2.00 <sup>a</sup>	12.67 ± 2.52 <sup>a</sup>
28.0	3.00 ± 1.41 <sup>a</sup>	3.67 ± 0.57 <sup>a</sup>	7.33 ± 1.15 <sup>ab</sup>	7.67 ± 1.53 <sup>a</sup>	9.33 ± 1.15 <sup>a</sup>	10.67 ± 0.58 <sup>a</sup>	12.33 ± 1.15 <sup>a</sup>	12.00 ± 1.00 <sup>ab</sup>	

Values are mean ± standard deviation of triplicate determinations.

Values with different superscript on the same column are significantly different (p < 0.05) while values marked asterisk (\*) are significantly different from their controls.

**Table 2** Effect of biochar remediation on the heavy metal concentration of *T. occidentalis* cultivated on gas-flared and non-gas-flared soils

Heavy metal (mg kg <sup>-1</sup> )	GP 0 (0 t ha <sup>-1</sup> )	GP I (7.1 t ha <sup>-1</sup> )	GP II (13.9 t ha <sup>-1</sup> )	GP III (20.9 t ha <sup>-1</sup> )	GP IV (28.0 t ha <sup>-1</sup> )
Fe (GFTO)	103.25 ± 9.73	108.57 ± 12.03 <sup>a</sup>	135.80 ± 20.06 <sup>a*</sup>	97.74 ± 27.26 <sup>a</sup>	93.48 ± 9.73 <sup>a</sup>
Fe (NGFTO)	126.14 ± 6.56 <sup>a</sup>	98.15 ± 2.51 <sup>bc</sup>	97.79 ± 3.31 <sup>bc</sup>	89.24 ± 3.73 <sup>c</sup>	117.56 ± 10.50 <sup>ab</sup>
Cu (GFTO)	0.55 ± 0.05	0.58 ± 0.06 <sup>a</sup>	0.72 ± 0.11 <sup>a*</sup>	0.52 ± 0.14 <sup>a</sup>	0.50 ± 0.50 <sup>a</sup>
Cu (NGFTO)	0.67 ± 0.03 <sup>a</sup>	0.52 ± 0.01 <sup>bc</sup>	0.52 ± 0.09 <sup>bc</sup>	0.47 ± 0.02 <sup>c</sup>	0.62 ± 0.06 <sup>ab</sup>
Zn (GFTO)	20.65 ± 1.95	21.71 ± 2.41 <sup>a</sup>	27.16 ± 4.01 <sup>a*</sup>	19.55 ± 5.45 <sup>a</sup>	18.70 ± 1.95 <sup>a</sup>
Zn (NGFTO)	25.23 ± 1.31 <sup>a</sup>	19.63 ± 0.50 <sup>bc</sup>	19.56 ± 3.49 <sup>bc</sup>	17.85 ± 0.75	23.51 ± 2.10 <sup>ab</sup>
Pb (GFTO)	0.26 ± 0.02 <sup>bc</sup>	0.37 ± 0.01 <sup>a</sup>	0.30 ± 0.01 <sup>bc</sup>	0.32 ± 0.03 <sup>ab</sup>	0.24 ± 0.02 <sup>c</sup>
Pb (NGFTO)	0.32 ± 0.02 <sup>a</sup>	0.25 ± 0.01 <sup>bc</sup>	0.25 ± 0.04 <sup>bc</sup>	0.23 ± 0.01 <sup>c</sup>	0.30 ± 0.03 <sup>ab</sup>
Cr (GFTO)	2.66 ± 0.25 <sup>bc</sup>	3.77 ± 0.14 <sup>a</sup>	2.99 ± 0.09 <sup>bc</sup>	3.23 ± 0.30 <sup>ab</sup>	2.41 ± 0.25 <sup>c</sup>
Cr (NGFTO)	3.25 ± 0.17 <sup>a</sup>	2.53 ± 0.06 <sup>bc</sup>	2.52 ± 0.04 <sup>bc</sup>	2.30 ± 0.10	3.03 ± 0.27 <sup>ab</sup>
Co (GFTO)	6.51 ± 0.61 <sup>bc</sup>	9.21 ± 0.34	7.31 ± 0.21	7.88 ± 0.72 <sup>ab</sup>	5.89 ± 0.61
Co (NGFTO)	7.95 ± 0.41 <sup>a</sup>	6.18 ± 0.16	6.16 ± 1.10	5.62 ± 0.24	7.41 ± 0.66
Cd (GFTO)	0.06 ± 0.01 <sup>c</sup>	0.08 ± 0.00 <sup>a</sup>	0.07 ± 0.00 <sup>bc</sup>	0.07 ± 0.01 <sup>ab</sup>	0.05 ± 0.01 <sup>c</sup>
Cd (NGFTO)	0.07 ± 0.00 <sup>a</sup>	0.06 ± 0.00 <sup>bc</sup>	0.06 ± 0.01 <sup>bc</sup>	0.05 ± 0.00	0.07 ± 0.01 <sup>ab</sup>
Ni (GFTO)	3.08 ± 0.29	4.36 ± 0.16 <sup>a</sup>	3.46 ± 0.10 <sup>bc</sup>	3.73 ± 0.34 <sup>ab</sup>	2.79 ± 0.29
Ni (NGFTO)	3.77 ± 0.20 <sup>a</sup>	2.93 ± 0.07 <sup>bc</sup>	2.92 ± 0.52 <sup>bc</sup>	2.66 ± 0.11	3.51 ± 0.31 <sup>ab</sup>

Values are mean ± standard deviation of triplicate determinations.

Values with different superscript (a, b, c) on the same row are significantly different ( $p < 0.05$ ) while values marked asterisk (\*) are significantly different from their controls.

GFTO, Gas-flared *Telfairia occidentalis*; NGFTO, Non-gas-flared *Telfairia occidentalis*

biochar and lowest for the 28.0 t ha<sup>-1</sup> biochar-treated group, while the NGFTO treated with 20.9 t ha<sup>-1</sup> biochar had the least nickel concentration. Biochar administered to the two soils reduced uptake by plants as shown by our result. Human beings are often exposed to heavy metal contamination through the food chain as they are transferred from soil to plants (Khan et al. 2010). They cause serious health challenges when their concentrations exceed the normal threshold (Al-Wabel et al. 2014). Some heavy metals are known to alter normal body metabolism, disrupt transfer of hereditary materials from parents to offsprings, and affect proper growth and development of fetus (Ali et al. 2013). Heavy metals such as chromium, copper, cadmium, and lead are well known for their toxicity when consumed at concentrations beyond the permissible limits (Dursun 2006; Kurniawan et al. 2006). Copper contamination can cause gastrointestinal cancer in humans (Turkdogan et al. 2003). Cadmium toxicity is responsible for kidney damage and can cause “itai-itai” in man. Zinc is an essential element that is toxic at higher concentrations (Baccio et al. 2005). Chromium is harmful to plants and animals; chromium (IV) ion alters soil biological activities and is carcinogenic (Javied et al. 2009). Cobalt causes bone marrow hyperplasia, acute poisoning, allergic reactions, seizures, and paralysis of nervous system. Lead is very poisonous; it affects the cardiovascular system and causes stroke and cognitive impairment (Evangelou et al. 2007). Our finding has shown that heavy metal adsorption by the *T. occidentalis* leaves decreased as the rate of biochar application increased with 20.9 t ha<sup>-1</sup> being the most effective. This result suggest that using biochar to cultivate this vegetable could lead to production of better quality vegetables, reducing the prevalence of heavy metal toxicity and hence improving nutrition of the consumers.

---

## Conclusion

The chapter has shown that vegetable farming is mostly engaged by females. Biochar use enhanced the growth parameters and reduced heavy metal uptake by the plants. Therefore, biochar use should be encouraged to remediate heavy metal polluted soils, to ensure maximum crop yield and food security. Increased sensitization is needed to encourage the use of biochar in gas flaring polluted areas to ensure that good quality vegetables are available for consumers.

**Acknowledgments** This research is supported by funding from the Department for International Development (DFID) under the Climate Impacts Research and Leadership Enhancement (CIRCLE) program.

---

## References

- Aaron KK (2006) Human rights violation and environmental degradation in the Niger-Delta. In: Porter E, Offord B (eds) Activating human rights. Barnes, Oxford/New York
- Abua MA, Ashua SW (2015) The impact of gas flaring on plant diversity in Ibeno local government area. *J Agric Ecol Res Int* 4(1):10–17

- Achi C (2003) Hydrocarbon exploitation, environmental degradation and poverty: the Niger Delta experience. In: Diffuse pollution conference, Dublin 2003 2B policy/socio-economics
- Adewale OO, Mustapha U (2015) The impact of gas flaring in Nigeria. *Int J Sci Technol Soc* 3 (2):40–50
- Adger WN et al (2009) Are there social limits to adaptation to climate change? *Clim Chang* 93 (3–4):335–354
- Adienbo OM, Nwafor A (2010) Effect of prolonged exposure to gas flaring on some haematological parameters of humans in the Niger Delta region of Nigeria. *J Appl Sci Environ Manag* 14 (1):13–15
- Agboola MO, Nwulu NI, Egelioglu F, Agboola OP (2011) Gas flaring in Nigeria: opportunity for household cooking utilization. *Int J Therm Environ Eng* 2:73
- Ajugwo AO (2013) Negative effects of gas flaring: the Nigerian experience. *J Environ Pollut Hum Health* 1:6–8
- Akachukwu D, Gbadegesin MA, Ojmelukwe PC, Atkinson CJ (2018) Biochar remediation improves the leaf mineral composition of *Telfairia occidentalis* grown on gas flared soil. *Plants* 7(3):57
- Ali H, Khan E, Sajad MA (2013) Phytoremediation of heavy metals-concepts and applications. *Chemosphere* 91(7):869–881
- Al-Wabel MI, Usman ARA, El-Naggar AH, Aly AA, Ibrahim HM, Elmaghraby S, Al-Omran A (2014) Conocarpus biochar as a soil amendment for reducing heavy metal availability and uptake by maize plants. *Saudi J Biol Sci* 22:503–511
- Amadi AN (2014) Impact of gas-flaring on the quality of rain water, groundwater and surface water in parts of Eastern Niger Delta, Nigeria. *J Geosci Geomatics* 2(3):114–119
- Amaechi CF, Biose E (2016) Gas flaring: carbon dioxide contribution to global warming. *J Appl Sci Environ Manag* 20:309–317. <https://www.ajol.info/index.php/jasem/article/view/140405>. Accessed 19 Dec 2019
- Aminu H, Shamsuddeen L (2019) Effect of Daniella olivera wood biochar on the growth and biomass of maize (*Zeamays* L.) in Lafia, North Central Nigeria. *J Dryland Agric* 5(3):25–32
- Ana GR (2011) Air pollution in the Niger Delta area: scope, challenges and remedies. In: Khallaf M (ed) The impact of air pollution on health, economy, environment and agricultural sources. InTech. ISBN: 978-953-307-528-0. <http://www.intechopen.com/books/the-impact-of-air-pollution-on-health-economy-environment-and-agricultural-sources/air-pollution-in-the-niger-delta-area-scope-challenges-and-remedies>
- Ana GREE, Sridhar MKC, Bamgboye EA (2009) Environmental risk factors and health outcomes in selected communities of the Niger Delta area, Nigeria. *Perspect Public Health* 129(4): 183–191
- Anacletus F, Adisa OI, Uwakwe A (2014) Effect of gas flaring on some phytochemicals and trace metals of fluted pumpkin (*Telferia occidentalis*). *J Environ Earth Sci* 4(16):1–5
- Anomohanran O (2012) Thermal effect of gas flaring at ebedei area of Delta State, Nigeria. *Pac J Sci Technol* 13:555–560. [http://www.akamaiuniversity.us/PJST13\\_2\\_555.pdf](http://www.akamaiuniversity.us/PJST13_2_555.pdf). Accessed 19 Dec 2019
- Baccio D, Kopriva S, Sebastiani H, Rennenberg L (2005) Does glutathione metabolism have a role in the defence of poplar against zinc excess. *New Phytol* 167:73–80
- Bailey VL, Fansler SJ, Smith JL, Bolton H (2011) Reconciling apparent variability in effects of biochar amendment on soil enzyme activities by assay optimization. *Soil Biol Biochem* 43:296
- Bernstein L, Bosch P, Canziani O, Chen Z, Christ R, Davidson O (2007) Climate change 2007: synthesis report. Summary for policymakers. IPCC, Geneva, p 22
- Bhatia R, Wernham A (2009) Integrating human health into environmental impact assessment: an unrealized opportunity for environmental health and justice. *Ciênc Saúde Colet* 14(4): 1159–1175
- Buzcu-Guven B, Harriss R (2012) Extent, impacts and remedies of global gas flaring and venting. *Carbon Manag* 3(1):95–108

- Campbell LGM (2004) A voluntary standard for global gas flaring and venting reduction. World Bank Group, Oil, Gas, Mining and Chemicals Department, Washington, DC
- Creech H, Akoh B, Parry JE (2014) ICTs for climate change adaptation in Africa. World Bank, Washington, DC
- Deressa TT, Hassan RM, Ringler C (2011) Perception of and adaptation to climate change by farmers in the Nile basin of Ethiopia. *J Agric Sci* 149:23
- Dispenza V, De Pasquale C, Fascella G, Mammano MM, Alonzo G (2016) Use of biochar as peat substitute for growing substrates of *Euphorbia* × *lomi* potted plants. *Span J Agric Res* 14(4): e0908
- Donwa PA, Mgbame CO, Utomwen OA (2015) Gas flaring in the oil and gas sector in Nigeria. *Int J Commer Manag Res* 1(1):28–39
- Dung E, Bombom L, Agusomu T (2008) The effects of gas flaring on crops in the Niger Delta, Nigeria. *GeoJournal* 73(4):297–305
- Dursun AYA (2006) Comparative study on determination of the equilibrium, kinetic and thermodynamic parameters of biosorption of copper(II) and lead(II) ions onto pretreated *Aspergillus Niger*. *Biochem Eng J* 28(2):187–195
- Ede PN, Edokpa DO (2015) Regional air quality of the Nigeria's Niger Delta. *Open J Air Pollut* 4:7–15
- Ede PN, Edokpa DO, Ayodeji O (2011) Aspects of air quality status of Bonny Island, Nigeria attributed to an LNG plant. *Energy Environ* 22(7):891–909
- Edino MO, Nsofor GN, Bombom LS (2009) Perceptions and attitudes towards gas flaring in the Niger Delta, Nigeria. *Environmentalist* 30:67–75
- Efe SI (2010) Spatial variation in acid and some heavy metal composition of rainwater harvesting in the oil producing region of Nigeria. *Nat Hazards* 55:307
- Efe SI (2011) Spatial variation of acid rain and its ecological effect in Nigeria. In: Proceedings of the environmental management conference, Federal University of Agriculture, Abeokuta, pp 381–396
- Efe SI, Mogborukor JOA (2008) Acid rain in the Niger Delta region: implication on water resource crises. In: Proceedings, international conference on the Nigerian state, oil industry and the Niger Delta, 11–13th March, 2008, Glory land Cultural Centre, Yenagoa
- Ekpoh I, Obia A (2010) The role of gas flaring in the rapid corrosion of zinc roofs in the Niger Delta region of Nigeria. *Environmentalist* 30(4):347–352
- Elvidge CD, Ziskin D, Baugh KE, Tuttle BT, Ghosh T, Pack DW, Erwin EH, Zhizhin M (2009) A fifteen year record of global natural gas flaring derived from satellite data. *Energies* 2(3): 595–622
- Emam EA (2016) Environmental pollution and measurement of gas flaring. *Int J Innov Res Sci Eng Technol* 2:252–262. <https://pdfs.semanticscholar.org/0463/5c29995aefa3f8f7d431d4ca6a35d22c4813.pdf>. Accessed 19 Dec 2019
- Epidi JO, Izah SC, Ohimain EI, Epidi TT (2016a) Phytochemical, antibacterial and synergistic potency of tissues of *Vitex grandifolia*. *Biotechnol Res* 2(2):69–76
- Epidi JO, Izah SC, Ohimain EI (2016b) Antibacterial and synergistic efficacy of extracts of *Alstonia boonei* tissues. *Br J Appl Res* 1(1):0021–0026
- European Union (2015) Life and climate change bulletin. Publications Office of the European Union, Luxembourg, pp 1–113. [https://www.google.com/search?client=firefox-b-d&q=life\\_climate\\_change\\_adaptation\\_en](https://www.google.com/search?client=firefox-b-d&q=life_climate_change_adaptation_en)
- Evangelou MWH, Ebel M, Schaeffer A (2007) Chelate assisted phytoextraction of heavy metals from soil. Effect, mechanism, toxicity, and fate of chelating agents. *Chemosphere* 68 (6):989–1003
- Fang Y, Singh B, Singh BP (2015) Effect of temperature on biochar priming effects and its stability in soils. *Soil Biol Biochem* 80:136–145
- Fankhauser S (2017) Adaptation to climate change. *Ann Rev Resour Econ* 9(1):209–230
- FAO (Food and Agriculture Organization of the United Nations) FAOSTAT (2008)

- Fawole OG, Cai XM, MacKenzie AR (2016) Gas flaring and resultant air pollution: a review focusing on black carbon. *Environ Pollut* 216:182–197
- Fluenta (2019) Reducing flaring in Nigeria: presidential approval. <https://www.fluenta.com/reducing-flaring-in-nigeria-presidential-approval/>. Accessed 16 July 2020
- Galloway JN, Townsend AR, Erisman JW, Bekunda M, Cai Z, Freney JR, Martinelli LA, Seitzinger SP, Sutton MA (2008) Transformation of the nitrogen cycle: recent trends, questions, and potential solutions. *Science* 320:889–892
- Giwa SO, Adama OO, Akinyemi OO (2014) Baseline black carbon emissions for gas flaring in the Niger Delta region of Nigeria. *J Nat Gas Sci Eng* 20:373–379
- Giwa SO, Kuye SI, Adama KO (2019) Gas flaring attendant impacts of criteria and particulate pollutants: a case of Niger Delta region of Nigeria. *J King Saud Univ Eng Sci* 31:209–217
- Global Gas Flaring Reduction Partnership (GGFR) (2015) <https://www.worldbank.org/en/programs/gasflaringreduction>. Accessed 5 Nov 2019
- Gobo AE, Richard G, Ubong IU (2009) Health impact of gas flares on Igwurata / Umuchem communities in Rivers State. *J Appl Sci Environ Manage* 13(3):27–33
- Gorovtsov AV, Sazykin IS, Sazykina MA (2018) The influence of heavy metals, polyaromatic hydrocarbons, and polychlorinated biphenyls pollution on the development of antibiotic resistance in soils. *Environ Sci Pollut Res* 25(10):9283–9292
- Graber ER, Harel YM, Kolton M, Cytryn E, Silber A, David DR, Tschansky L, Borenshtein M, Elad Y (2010) Biochar impact on development and productivity of pepper and tomato grown in fertigated soilless media. *Plant Soil* 337:481–496
- Guttikunda SK, Calori G (2013) A GIS based emissions inventory at 1 km × 1 km spatial resolution for air pollution analysis in Delhi, India. *Atmos Environ* 67:101–111
- Houben D, Evrard L, Sonnet P (2013) Mobility, bioavailability and PH-dependent leaching of cadmium, zinc and lead in a contaminated soil amended with biochar. *Chemosphere* 92:1450–1457
- ICF (2006) Nigeria: guidebook for carbon credit development for flare reduction projects. International. June 2006
- Ifemeje JC (2015) Effect of gas flaring on the anti-nutritional composition of four green leafy vegetables from Eleme in Rivers State, Nigeria. *Int J Environ Pollut Solut* 3(1):31–37. Columbia International Publishing
- IPCC (2013) Climate change 2013. The physical science basis. Contribution of working group I to the fifth assessment report of the Intergovernmental Panel on Climate Change. Cambridge University Press, Cambridge, UK, 2014
- IPCC (2014a) Climate change 2014. Impacts, adaptation and vulnerability-contribution of working group II to the fifth assessment report of Intergovernmental Panel on Climate Change. Cambridge University Press, Cambridge, UK
- IPCC (2014b) Climate change 2014: synthesis report. Intergovernmental panel on climate change, Geneva
- IPCC (2018) Global warming of 1.5 °C. An IPCC Special report on the impacts of global warming of 1.5 °C above pre-industrial levels and related global greenhouse gas emission pathways, in the context of strengthening the global response to the threat of climate change. Intergovernmental Panel on Climate Change. <https://www.ipcc.ch/sr15/download/#full>. Accessed 5 Nov 2019
- Ismail OS, Umukoro GE (2012) Global impact of gas flaring. *Energy Power Eng* 4(4):290–302
- Ite AE, Ibok UJ (2013) Gas flaring and venting associated with petroleum exploration and production in the Nigeria's Niger Delta. *Am J Environ Prot* 1:70–77
- Iyorakpo J, Odibikuma PW (2015) Impact of gas flaring on the built environment: the case of Ogba/Egbema/Ndoni Local Govt Area, Rivers State, Nigeria. *Eur Sci J* 11(26):83–95
- Jacobson JS (1984) Effect of acidic aerosol, fog, mist and rain on crops and trees. *Philos Trans R Soc Lond B* 49:327–338
- Javied S, Mehmood T, Choodhry MM, Tufail M, Irfan N (2009) Heavy metal pollution from phosphate rock used for the production of fertilizer in Pakistan. *Microchem J* 91:94–99

- Kampa M, Castanas E (2008) Human health effects of air pollution. *Environ Pollut* 151:362–367
- Karamesouti M, Gasparatos D (2008) Sustainable management of soil phosphorus in a changing world. In: Rakshit S, Abhilash PC, Singh HB, Ghosh S (eds) *Adaptive soil management – from theory to practices*. Springer, Berlin
- Keller M (2009) Climate risks and development projects: an assessment report for a community-level project in Guduru, Oromiya, Ethiopia, Swiss Interchurch Aid (HEKS)
- Khan S, Rehman S, Khan AZ, Khan MA, Shah MT (2010) Soil and vegetables enrichment with heavy metals from geological sources in Gilgit, Northern Pakistan. *Ecotoxicol Environ Saf* 73:1820–1827
- Kurniawan TA, Chan GY, Lo WH, Babel S (2006) Comparisons of low-cost adsorbents for treating waste waters laden with heavy metals. *Sci Total Environ* 366(2–3):409–426
- Lehmann J (2007) Bio-energy in the black. *Front Ecol Environ* 5:381–387
- Lehmann J, Joseph S (2009) Biochar for environmental management: an introduction. In: Lehmann J, Joseph S (eds) *Biochar for environmental management, science and technology*. Earthscan, London, pp 1–12
- Lehmann J, Gaunt J, Rondon M (2006) Biochar sequestration in terrestrial ecosystems—a review. *Mitig Adapt Strateg Glob Chang* 11:395–419
- Malumfashi GI (2007) Phase-out of gas flaring in Nigeria by 2008: the prospects of a multi-win project. Review of the regulatory, environmental and socio-economic issues. *Niger Gas Flaring Pet Train J* 4:1–39
- McGlade C, Ekins P (2015) The geographical distribution of fossil fuels unused when limiting global warming to 2 °C. *Nature* 517:187–190
- Mertz O, Mbow C, Reenberg A, Diouf A (2009) Farmers' perceptions of climate change and agricultural adaptation strategies in rural Sahel. *Environ Manag* 43(5):804–816
- Mohammed AA, Mohammed MA, Ahmed MM (2016) Recovery of natural gas liquids and produce liquified petroleum gas from associated natural gas. Sudan University of Science & Technology. Available at: <http://repository.sustech.edu/handle/123456789/15090>
- Neufeld HS, Jernstedt JA, Haines BL (1985) Direct foliar effects of simulated acid rain. I. Damage, growth and gas exchange. *New Phytol* 99(3):389–405
- Nguyen B, Lehmann J, Kinyangi J, Smernik R, Riha SJ, Engelhard MH (2008) Long-term black carbon dynamics in cultivated soil. *Biogeochemistry* 89:295–308
- Nigerian National Petroleum Corporation (2017) NNPC: Nigeria drops to seventh highest gas flaring country. <https://www.thisdaylive.com/index.php/2017/04/03/nnpc-nigeria-drops-to-seventh-highest-gas-flaring-country/>. Accessed 20 July 2020
- Nkwocha EE, Pat-Mbano EC (2010) Effect of gas flaring on buildings in the oil producing rural communities of River State, Nigeria. *Afr Res Rev* 4(2):90–102
- Nriagu J, Udofia EA, Ekong I, Ebuk O, Sambo AS (2008) The role of energy in achieving millennium development goal (MDGs). Keynote address at the national engineering technology conference (NETec 2008). Ahmadu Bello University, Zaria held on 1st of April, 2008
- O'Neill B, Grossman J, Tsai MT, Gomes JE, Lehmann J, Peterson J, Neves E, Thies JE (2009) Bacterial community composition in Brazilian Anthrosols and adjacent soils characterized using culturing and molecular identification. *Microb Ecol* 58:23–35
- Odjugo PAO (2007) Some effects of gas flaring on the microclimate of yam and cassava production in Erhorike and environs. Delta State, Nigeria. *Niger Geogr J* 5:43
- Odjugo PAO, Osemwenkhae EJ (2009) Natural gas flaring affects microclimate and reduces maize (*Zea mays*) yield. *Int J Agric Biol* 11:408–412
- Odumugbo CA (2010) Natural gas utilisation in Nigeria: challenges and opportunities. *J Nat Gas Sci Eng* 2:310–316
- Ogunkoy OO, Efi EJ (2003) Rainfall quality and sources of rainwater acidity in Warri area of the Niger Delta, Nigeria. *J Min Geol* 39(2):125–130
- Ohimain EI (2013a) Can the Nigerian biofuel policy and incentives (2007) transform Nigeria into a biofuel economy? *Energy Policy* 54:352–359

- Ohimain EI (2013b) The challenges of liquid transportation fuels in Nigeria and the emergence of the Nigerian automotive biofuel programme. *Res J Appl Sci Eng Technol* 5(16):4058–4065
- Ojeh VN (2012) Sustainable development and gas flaring activities: a case study of Ebodei area of Ukwuani LGA, Delta State, Nigeria. *Resour Environ* 2(4):169–174
- Ojide M, Kareem S, Kari F, Gazi A, Matuin O (2012) Impact of gas industry on sustainable economy in Nigeria: further estimations through e-view. *J Appl Sci* 12:2244–2251
- Okeke PN, Okpala CQ (2014) Effects of gas flaring on selected arable soil quality indicators in the Niger Delta, Nigeria. *Sky J Soil Sci Environ Manag* 3(1):001–005
- Okonwu K, Mensah SI (2012) Effects of NPK (15:15:15) fertilizer on some growth indices of pumpkin. *Asian J Agric Res* 6:137–143
- Okorie A (2018) The dominance of foreign capital and its impact on Indigenous technology development in the production of liquefied natural gas in Nigeria. *Rev Afr Polit Econ* 45:478–490
- Olisemauche OO, Avwerosuoghene OP (2015) The effect of gas flaring on agricultural production of Okpai, Ndukwa East Local Government Area, Delta State, Nigeria. *Stand Sci Res Essays* 3(9):266–272
- Olobaniyi SB, Efe SI (2007) Comparative assessment of rainwater and groundwater in the oil producing area of Nigeria: environment and health implication. *J Environ Health* 6(2):111–117
- Olukoya OAP (2015) Negative effects of gas flaring on buildings and public health in oil producing communities: the Ogbia community, Bayelsa State case. *Int J Environ Monit Prot* 2(5):52–61
- Orlando O (2006) Construction and networking of gas distribution infrastructure, Chartered Institute of Bankers of Nigeria, (2006) Oil and gas financing in Nigeria issues, challenges and prospects. The Chartered Institute of Bankers of Nigeria, Lagos, p 243
- Osuji LC, Onojake CM (2004) Trace heavy metals associated with crude oil: a case study of Ebocha-8 oil-spill-polluted site in Niger Delta, Nigeria. *Chem Biodivers* 1(11):1708–1715
- Otitoloju A, Dan-Patrick J (2010) Effects of gas flaring on blood parameters and respiratory system of laboratory mice, *Mus musculus*. *Environmentalist* 30:340–346
- Ovuakporaye SI, Aloamaka CP, Ojeh AE, Ejebe DE, Mordi JC (2012) Effect of gas flaring on lung function among residents in gas flaring community in Delta State, Nigeria. *Res J Environ Earth Sci* 4(5):525–528
- Oyedepo SO (2014) Towards achieving energy for sustainable development in Nigeria. *Renew Sust Energ Rev* 34:255–272
- Ozabor F, Obisesan A (2015) Gas flaring: impacts on temperature, agriculture and the people of Ebodei in Delta State Nigeria. *J Sustain Soc* 4(2):5–12
- Pary ML, Canziani OF, Palutikof JP, van der Linden PJ, Hanson CE (eds) (2007) Cross-chapter case study. In: *Climate change 2007: impacts, adaptation and vulnerability. Contribution of working group II to the fourth assessment report of the Intergovernmental Panel on Climate Change*. Cambridge University Press, Cambridge
- Patz JA, Gibbs HK, Foley JA, Rogers JV, Smith KR (2007) Climate change and global health: quantifying a growing ethical crisis. *EcoHealth* 4:397–405
- Pearce DW, Cline WR, Achanta AN, Fankhauser S, Pachauri RK, Tol RSJ et al (1996) The social costs of climate change: greenhouse damage and the benefits of control. In: Bruce JP, Lee H, Haites EF (eds) *Climate change 1995: economic and social dimensions-contribution of working group III to the second assessment report of the Intergovernmental Panel on Climate Change*. Cambridge University Press, Cambridge, pp 179–224
- Rhodes CJ (2019) *Sci Prog* 102(1):73–89
- Shaaban M, Petintin JO (2014) Renewable energy potentials in Nigeria: meeting rural energy needs. *Renew Sustain Energy Rev* 29:72–84
- Silva RVD, Rodrigues LA, Mauricio GSD, Marco AS, Bruna GD, Martins MA (2019) Biochar and mucuna increase papaya plant growth and nutrition, as well as soil fertility. *Pesqui Agropecu Trop* 49(e55210):1–10
- Smith JL, Collins HP, Bailey VL (2010) The effect of young biochar on soil respiration. *Soil Biol Biochem* 42:2345–2347



- Sohi S, Lopez-Capel E, Krull E, Bol R (2009) Biochar, climate change and soil: a review to guide future research. CSIRO Land and Water science report, 5/09. CSIRO Land and Water, Canberra, p 02
- Sojinu OSS, Wang JZ, Sonibare OO, Zeng EY (2010) Polycyclic aromatic hydrocarbons in sediments and soils from oil exploration areas of the Niger Delta, Nigeria. *J Hazard Mater* 174(1–3):641–647
- Sonibare J, Adebisi F, Obanijesu E, Okelana O (2010) Air quality index pattern around petroleum production facilities. *Manag Environ Qual Int J* 21(3):379–392
- Swanson J (2013) Climate-change mitigation potential of biochar: a review and framework for carbon accounting. MSc thesis, Duke Environmental Leadership Master of Environmental Management, Nicholas School of Environment, Duke University, Durham, pp 1–39
- Tawari CC, Abowei JFN (2012) Air pollution in the Niger Delta area of Nigeria. *Int J Fish Aquat Sci* 1:94–117
- Turkdogan MK, Fevzi K, Kazim K, Ilyas T, Ismail U (2003) Heavy metals in soil, vegetables and fruits in the endemic upper gastrointestinal cancer region of Turkey. *Environ Toxicol Pharmacol* 13:175–179
- Ubani EC, Onyejekwe IM (2013) Environmental impact analyses of gas flaring in the Niger Delta region of Nigeria. *Am J Sci Ind Res* 4(2):246–252
- Ujowundu CO, Nwaogu LA, Ujowundu FN, Belonwu DC (2013) Effect of gas flaring on the phytochemical and nutritional composition of *Treculia africana* and *Vigna subterranean*. *Br Biotechnol J* 3(3):293–304
- Ukala E (2011) Gas flaring in Nigeria's Niger Delta: failed promises and reviving community voices. *J Energy Clim Environ* 97:97–126
- UNFCCC (2015) Adoption of the Paris Agreement. <https://unfccc.int/resource/docs/2015/cop21/eng/l09.pdf>. Accessed 5 Nov 2019
- Wang T, Camps-Arbestain M, Hedley M, Bishop P (2012) Predicting phosphorous bioavailability from high-ash biochars. *Plant Soil* 357:173–187
- Weyant CL, Shepson PB, Subramanian R, Cambaliza MOL, Heimburger A, McCabe D, Baum E, Stirm BH, Bond TC (2016) Black carbon emissions from associated natural gas flaring. *Environ Sci Technol* 50:2075–2081
- Woolf D, Amonette JE, Street-Perrott FA, Lehmann J, Joseph S (2010) Sustainable biochar to mitigate global climate change. *Nat Commun* 1:56
- Yaduma N, Kortelainen M, Wossink A (2013) Estimating mortality and economic costs of particulate air pollution in developing countries: the case of Nigeria. *Environ Resour Econ* 54:361–387
- Zhao S, Alexandroff A (2019) Current and future struggles to eliminate coal. *Energy Policy* 129:511–520
- Zhou Y, Cheng S, Chen D, Land J, Zhao B, Wei W (2014) A new statistical approach for establishing high-resolution emission inventory of primary gaseous air pollutants. *Atmos Environ* 94:392–401

**Open Access** This chapter is licensed under the terms of the Creative Commons Attribution 4.0 International License (<http://creativecommons.org/licenses/by/4.0/>), which permits use, sharing, adaptation, distribution and reproduction in any medium or format, as long as you give appropriate credit to the original author(s) and the source, provide a link to the Creative Commons license and indicate if changes were made.

The images or other third party material in this chapter are included in the chapter's Creative Commons license, unless indicated otherwise in a credit line to the material. If material is not included in the chapter's Creative Commons license and your intended use is not permitted by statutory regulation or exceeds the permitted use, you will need to obtain permission directly from the copyright holder.





# Sustaining a Cleaner Environment by Curbing Down Biomass Energy Consumption

# 69

Abubakar Hamid Danlami and Shri Dewi Applanaidu

## Contents

Introduction .....	1424
Literature Review .....	1426
Theoretical Frameworks .....	1427
Equilibrium Level of Utility for Households That Use Only One of These Energy Sources .....	1428
Equilibrium Point for Households That Use Gas as Their Only Source of Energy .....	1428
Derivation of Equilibrium Point for Households That Use Liquid Fuel as the Only Source of Energy .....	1429
Utility Maximization Point for Households That Use Only Biomass Energy .....	1429
Utility Maximization of Households That Use All the Four Source of Energy Together .....	1430
Methodology .....	1430
Model Specification .....	1431
The OLS Model .....	1432
Analysis .....	1432
Determinants of Household Energy Switching .....	1433
Determinants of Household Traditional Energy Use .....	1435
Conclusions .....	1436
Policy Recommendations .....	1437
References .....	1437

This chapter was previously published non-open access with exclusive rights reserved by the Publisher. It has been changed retrospectively to open access under a CC BY 4.0 license and the copyright holder is “The Author(s)”. For further details, please see the license information at the end of the chapter.

A. H. Danlami (✉)

Department of Economics, Faculty of Social Sciences, Bayero University Kano, Kano, Nigeria

S. D. Applanaidu

Department of Economics and Agribusiness, School of Economics, Finance and Banking, College of Business, Universiti Utara Malaysia, Sintok, Malaysia

e-mail: [dewi@uum.edu.my](mailto:dewi@uum.edu.my)

© The Author(s) 2021

W. Leal Filho et al. (eds.), *African Handbook of Climate Change Adaptation*,  
[https://doi.org/10.1007/978-3-030-45106-6\\_211](https://doi.org/10.1007/978-3-030-45106-6_211)

1423

---

**Abstract**

Environmental degradation, soil erosion, and desertification are some of the consequences of high rate of traditional biomass fuel use by households in developing countries. The critical issues to raise here are how can these households be encouraged to change their energy consumption behavior? What are the factors that cause the rampant use of biomass fuel in developing countries? How and to what extent can these factors be manipulated so that households in developing countries are encouraged to adopt clean energy fuel an alternative to the most widely used biomass fuel? Therefore, this chapter tries to find answer to the above questions raised, by carrying out an in depth analysis of households' use of biomass fuel in developing countries using Bauchi State, Nigeria, as the case study. Cluster area sampling technique was utilized to generate the various responses, where a total number of 539 respondents were analyzed. The study estimated ordered logit model to analyze the factors that influence the movement of households along the energy ladder from nonclean energy to the cleaner energy. Furthermore, Ordinary Least Squares (OLS) model was estimated to analyze the impacts of socio-economic, residential, and environmental factors on biomass energy consumption. It was found that age of the household head and his level of education, income, living in urban areas, home ownership, and hours of electricity supply have positive and significant impact on household energy switching from traditional biomass energy use to the cleaner energy. Therefore, policies that will enhance household income and the increase in the availability of cheap cleaner energy will encourage households switching to cleaner energy sources thereby reducing the level of environmental pollution in the study area.

---

**Keywords**

Clean-energy · Households · OLS, Ordered-logit · Traditional-biomass

---

**Introduction**

Climate change which is the variation in climate overtime and its impacts on the environment and socio-economic systems now constitute the most important environmental problem facing mankind. According to UNDP (2013), climate change can affect both the human and the entire natural systems which pose a threat to human development and survival. Among the most important factors that caused climate change and environmental pollution is the wide spread use of biomass energy. Biomass fuels, which constitute animal dung, crop residues, fuel-wood, and charcoal, are among some of the most widely used fuels for cooking and heating, particularly in developing countries (Yamamoto et al. 2009). Currently, more than two billion people rely on biomass fuel globally to satisfy their basic energy needs. That is why this type of fuel accounts for about 20% of energy supply for the whole

world. IEA (2011) argued that if proper measures were not taken, the number of biomass fuel users globally may increase to about 2.7 billion people by the year 2030. A large number of biomass energy users, especially in traditional ways, are found mostly in Asia and Africa. For instance, the IEA (2011) reported that biomass fuel accounts for more than 50% of Africa's energy utilization. In Nigeria, the wide use of biomass fuel at household level is more than 70%. Coming down to the state level, the rate of biomass fuel use by households is about more than 90% in Bauchi State, Nigeria (NBS 2012).

However, such wider use of biomass fuel is unwholesome for human living and their environment. For instance, when combining CO<sub>2</sub> emissions and other GHG in a single index, biomass fuel scores much higher than other fossil fuels like LPG and kerosene. Moreover, there is higher correlation between the use of biomass fuel and indoor air pollution (Desalu et al. 2012; Risseuw 2012). Such indoor air pollution causes about 1.5 to 2 million losses of lives worldwide yearly. Environmental degradation, soil erosion, and desertification are some of the consequences of high rate of biomass fuel use in developing countries. In fact, Nigeria has been facing an annual average rate of deforestation over a previous decade due to high rate of biomass fuel use. Available data has shown that the nation's 15 million hectares of forest and woodland reserves could be depleted within the next 50 (Nnaji et al. 2012). In Bauchi State, the rampant use of biomass energy is so great to the extent of more than 600 kg per household monthly (Danlami et al. 2017). This has posed negative impacts on the inhabitant of the State such as the systematic destruction of the State's forest reserves and woodlands, soil erosion, and desertification whereby the State losses not less than 1 km of land yearly due to desertification as a result of high rate of felling trees (Danlami et al. 2017).

That is why the defunct United Nations Millennium Project recommended halving the number of households that depend on traditional biomass fuel by the year 2015, the target that was not complied by most of the participating countries including Nigeria (Naibbi and Healey 2013). The critical issues to raise here are that how can these households be encouraged to change their energy consumption behavior? what are the factors that cause the rampant use of biomass fuel in developing countries? how and to what extent can these factors be manipulated so that households in developing countries are encouraged to adopt clean energy fuel an alternative to the most widely used traditional biomass fuel? This is because clean fuel has greater capacity to do useful work. The use of clean fuel is an imperative to improve the standard of living of the households that heavily rely on biomass fuel (Lee 2013). Therefore, in line with the above issues raised, this chapter tries to find answer to the above questions raised by carrying out an in depth analysis of households' use of biomass fuel in developing countries using Bauchi State, Nigeria, as the case study. The remaining part of the chapter consists sections as follows. Section "Literature Review" constitutes review of related literature. Section "Theoretical Frameworks" is theoretical and conceptual frameworks of the study. Section "Methodology" highlights the methodology adopted. Section "Analysis" the discussion of findings. Section "Conclusions" highlights chapter conclusion. The last section constitutes the policy implications and recommendations.

## Literature Review

Studies that analyzed energy utilization can be classified into two categories. The first group consists of those studies (Danlami et al. 2018a, 2019a) that analyze aggregate energy consumption using time series data. Most of these studies concluded that energy consumption is highly correlated with environmental degradation. However, these conclusions have limited practical applicability at a microlevel, because the energy consumption behavior of households is heterogeneous, which is usually ignored in studies that utilized time series data. Moreover, the second category of studies are those that analyzed household energy consumption using microdata approach (Lee 2013; Mensah and Adu 2013; Ozcan et al. 2013; Abdurrazak et al. 2012; Couture et al. 2012; Laureti and Secondi 2012; Onoja 2012; Oyekale et al. 2012; Song et al. 2012; Ganchimeg and Havrland 2011; Jingchao and Kotani 2011; Jumbe and Angelsen 2010; Osiolo 2010; Suliman 2010; Danlami and Islam 2020; Danlami et al. 2017; Nlom and Karimov 2014; Ogwumike et al. 2014). These studies arrived at different conclusions based on the socio-economic, demographic, home, and environmental characteristics of the households under consideration.

The composition and type of socio-demographic factors of households determine their fuel switching and consumption behavior. For instance, Laureti and Secondi (2012) indicated that households which comprise of couples with children tend to adopt less of oil and electricity and more of coal-wood when compared with a household of a single person. This is contrary to the findings by Danlami et al. (2017) which concluded that the household that is headed by a married individual has higher odd of adopting clean fuel than otherwise. Whereas some previous studies (Osiolo 2010; Jumbe and Angelsen 2010; Nlom and Karimov 2014) reported no significant relationship between the gender of the household head and its energy consumption behavior, a study by Mensah and Adu (2013) found that there is a significant negative relationship between the household head being male and the adoption of clean energy. Meanwhile, age of the household head was found to have a negative impact on the adoption of clean energy (Suliman 2010; Mensah and Adu 2013; Nlom and Karimov 2014). Households adopt less clean energy source when the head is older. Additionally, the household head level of education was found to exact a positive impact on the adoption of clean energy. The higher the level of education of the household head, the lower the probability of adopting nonclean energy (Eakins 2013; Mensah and Adu 2013; Ozcan et al. 2013). The number of a household's members (i.e., household size) affects the household's energy switching decision, the larger the size of a household, the lesser the adoption of clean energy. This assertion is supported by previous studies (Ozcan et al. 2013; Mensah and Adu 2013; Suliman 2010; Heltberg 2005).

The factors that measure the economic status of the household influence the households' fuel consumption decision. For instance, studies have established that there is a positive relationship between income and adoption of clean energy (Danlami et al. 2017; Mensah and Adu 2013; Ozcan et al. 2013; Couture et al. 2012). Poorer households especially in developing countries tend to adopt biomass

fuels like firewood, plant residues, and animal dung. Furthermore, number of energy consuming appliances increases the quantity of energy consumption by households (Danlami 2017a; Eakins 2013). The higher the number of energy consuming appliances at home, the lesser the odd of adopting biomass source of energy (Danlami 2017b). Moreover, energy price has a negative relationship with energy consumption. When the price of a particular energy source is high, households switch to other alternative fuel available. This is in line with law of demand and also has been established by previous studies (Danlami 2017a; Nlom and Karimov 2014; Lee 2013).

Furthermore, the characteristics of the building in which the households live also affect their energy choice behavior. Factors such as size of the building, number of rooms in the home, share of dwelling and dwelling ownership have been established by previous studies to influence the manner of household energy consumption behavior (Danlami et al. 2017; Eakins 2013; Mensah and Adu 2013; Tchereni 2013). Lastly, environmental factors such as location of home, the extent of electricity supply, the main source of cooking, and lighting fuel in the area were found to influence the manner of household energy consumption. Households that live in the rural areas or the area whereby there is a wide spread use of biomass fuel tend to adopt biomass fuel as their main source of energy (Danlami 2017a, b; Ozcan et al. 2013).

Based on the above-reviewed literature, it can be seen that there exist inconsistencies as per the findings and conclusions of previous studies on the factors influencing household energy consumption and switching behavior, from one place to another, due to differences in environmental factors, cultural factors, socio-economic settings, as well as differences in the average level of development among different regions. Therefore, additional study on household energy choice and consumption in a specific area is an addition to the existing literature as argued by the previous studies (Danlami et al. 2015, 2017).

---

## Theoretical Frameworks

Households mostly use energy for indirect satisfaction mainly to produce another commodities or services (modified from Danlami et al. 2016). Households utilized energy from different sources for the purpose of maximizing satisfaction. This optimal level satisfaction is usually attained at the equilibrium point of particular energy consumption. For instance, equation (1) indicates a given utility function of energy consumption:

$$U = f(\in_c G_s \mathcal{L}_f \mathcal{B}_b) \quad (1)$$

Subject to household budget constraint as in equation (2):

$$Y = P_c \in_c + P_s G_s + P_f \mathcal{L}_f + P_b \mathcal{B}_b \quad (2)$$

where  $U =$  utility,  $\in_c =$  electric energy,  $G_s =$  gas energy,  $\mathcal{L}_f =$  liquid energy (i.e., fuel),  $\mathcal{B}_b =$  biomass energy,  $Y =$  income of household and  $P =$  price of the relevant energy.

To find the maximum point of household energy utilization, we form Langrangian multiplier function as in equation (3):

$$L = f(\in_c G_s \mathcal{L}_f \mathcal{B}_b) + \lambda(Y - P_c \in_c + P_s G_s + P_f \mathcal{L}_f + P_b \mathcal{B}_b = 0) \quad (3)$$

Using equation (3), we can analyze the maximum point of utility for:

- (i) Household that use only one of these energy sources
- (ii) Households that use all of these energy sources

### Equilibrium Level of Utility for Households That Use Only One of These Energy Sources

Assuming the households use only electricity as its sole source of energy, the utility maximization point will be

$$\frac{\partial L}{\partial \in_c} = f'_c - \lambda P_c = 0 \quad (4)$$

$$f'_c = \lambda P_c \quad (5)$$

Since the household utilized only single source of energy,  $\lambda = 1$

$$f'_c = P_c \quad (6)$$

Equation (6) indicates the point of utility maximization from using electric source of energy where the marginal utility obtained from consuming extra unit of electricity is equal to the price of that additional unit of electricity. Any increase in the consumption of electricity above the equilibrium level implies decrease in the total utility, while consumption of electricity below the equilibrium level implies that the total utility of electricity is not maximized because additional unit of electricity consumed will lead to increase in the total utility, until the above equilibrium point is reached.

### Equilibrium Point for Households That Use Gas as Their Only Source of Energy

In this case, we conduct the partial derivation of equation (3) with respect to gas. This is indicated in equation (7):

$$\frac{\partial L}{\partial G_s} = f'_s - \lambda P_s = 0 \quad (7)$$

$$f'_s = \lambda P_s \quad (8)$$

By definition,  $\lambda = 1$ , therefore, the utility maximization point will be

$$f'_s = P_s \quad (9)$$

that is, the point where the additional satisfaction obtained from using extra amount of gas is equal to the price of that additional unit of gas.

### Derivation of Equilibrium Point for Households That Use Liquid Fuel as the Only Source of Energy

Here, we find the partial derivative of equation (3) with respect to the liquid fuel as in equation (10):

$$\frac{\partial L}{\partial L_f} = f'_f - \lambda P_f = 0 \quad (10)$$

$$f'_f = \lambda P_f \quad (11)$$

Since  $\lambda = 1$  (for households that use only one source of energy)

$$f'_f = P_f \quad (12)$$

### Utility Maximization Point for Households That Use Only Biomass Energy

The partial derivative of equation (3) with respect to biomass energy is given by:

$$\frac{\partial L}{\partial B_b} = f'_b - \lambda P_b = 0 \quad (13)$$

$$f'_b = \lambda P_b \quad (14)$$

Since  $\lambda = 1$

$$f'_b = P_b \quad (15)$$

Equation (15) indicates the utility maximization point for household that utilizes only biomass energy. This is the point where the additional satisfaction obtained



from using an additional bundle of biomass energy is equal to the price of that additional bundle.

### Utility Maximization of Households That Use All the Four Source of Energy Together

In this situation, the utility of using energy is maximized, by consuming the energy up to the level where the ratio of extra satisfaction from using the additional amount of energy to their prices is equal. Taking back the earlier Langrangian multiplier utility function and the constraints for energy use

$$L = f(\in_c G_s \mathcal{L}_f \mathcal{B}_b) + \lambda(Y - P_c \in_c + P_s G_s + P_f \mathcal{L}_f + P_b \mathcal{B}_b = 0) \quad (16)$$

The partial derivatives with respect to each of the energy source are:

$$\frac{\partial L}{\partial \in_c} = f'_c - \lambda P_c = 0 \quad (17)$$

$$\frac{\partial L}{\partial G_s} = f'_s - \lambda P_s = 0 \quad (18)$$

$$\frac{\partial L}{\partial \mathcal{L}_f} = f'_f - \lambda P_f = 0 \quad (19)$$

$$\frac{\partial L}{\partial \mathcal{B}_b} = f'_b - \lambda P_b = 0 \quad (20)$$

$$\lambda = \frac{f'_c}{P_c} = \frac{f'_s}{P_s} = \frac{f'_f}{P_f} = \frac{f'_b}{P_b} \quad (21)$$

That is the utility maximization point for households that use all the four source of energy is for them to consume at the point where the ratio of the extra satisfaction from using additional unit from each of the energy source to their prices are equal.

---

## Methodology

Following Danlami et al. (2019b), the total sample size was determined based on Dillman (2011). A total of 750 questionnaires were distributed based on cluster area sampling method. Finally about 548 filled questionnaires were returned back (which is more than 70% of the total number of the issued questionnaires) out of which 9

questionnaires were discarded. Multistage cluster sampling was utilized as the sampling technique.

## Model Specification

### Ordered Logit Models

In order to satisfy the first objective of this chapter which is to assess the determinants of household fuel switching up the ladder from traditional biomass energy to the cleaner source of energy, ordered logit model was employed. Since household fuel switching consists of movement up the energy ladder in a hierarchical order which is the basis for ordered models (Kofarmata 2016). Therefore, due to the ordinal nature of the dependent variable, it is stated as movement in fuel the household switching from traditional biomass energy, transitional energy (kerosene), and the cleaner energy (gas and electricity sources of energy). Thus, the model can be stated as in equation (22):

$$y_i = \beta X_i + \varepsilon_i \quad (22)$$

where  $y_i$  is the observed and exact dependent variable (categories of fuel switching in hierarchical order); coded as 0, 1, . . . .  $n$ ,  $X_i$  is the vector of the independent variables.  $\beta$  is the vector of parameters to be estimated and  $\varepsilon_i$  is the random variable for the ordered logit model.

If the score on the observed variable say  $y_i$  is 0, means that the household uses traditional biomass energy. However, if the household adopts the transitional fuel (such as kerosene), then  $y_i = 1$ ; and if the household adopts cleaner source of energy (electricity/gas) then  $y_i = 2$ . Then the estimated empirical model is written as:

$$\begin{aligned} Y_i = & \alpha_0 + \beta_1 \text{GEN}_i + \beta_2 \text{AGE}_i + \beta_3 \text{EDU}_i + \beta_4 \text{HHS}_i + \beta_5 \text{INC}_i + \beta_6 \text{LOC}_i \\ & + \beta_7 \text{NRM}_i + \beta_8 \text{DSH}_i + \beta_9 \text{HRSE}_i + \beta_{10} \text{PFW}_i + \beta_{11} \text{NCF}_i \\ & + \beta_{12} \text{HAPP}_i + \beta_{13} \text{HOWN}_i + \varepsilon_i \end{aligned} \quad (23)$$

$Y_i$  = The dependent ordered variables summarized as: Traditional biomass ( $y_i = 0$ ),

Transitional energy ( $y_i = 1$ ) and Cleaner energy ( $y_i = 2$ )

$\text{GEN}_i$  = Gender of the head of household

$\text{AGE}_i$  = Age of the head of household

$\text{EDU}_i$  = Level of education of the head of household

$\text{HHS}_i$  = Size of the household

$\text{INC}_i$  = Monthly income of the head of household

$\text{LOC}_i$  = Home location of the household

$\text{NRM}_i$  = Number of rooms in the home

$\text{DSH}_i$  = Size of the dwelling of the household

$\text{HRSE}_i$  = Hours of electricity supply

$PFW_i$  = Unit price of firewood per bundle

$NCF_i$  = Similarity with the neighbor's main cooking fuel source

$HAPP_i$  = Home appliances

$HOWN_i$  = Home ownership

## The OLS Model

Another objective of this study is to assess the determinants of household for biomass energy in Bauchi State.

Following Danlami (2014) and Lee (2013), the implicit form of the relationship between households' consumption of a particular energy and its determinants can be expressed as:

$$Y_i = \beta_0 + \sum_{i=0}^k \beta_i X_i \quad (24)$$

where  $Y_i$  is household  $i$ 's consumption of biomass energy.

The estimated empirical OLS model for households' biomass energy consumption is expressed as:

$$\ln FWD_i = \alpha_0 + \beta_1 GEN_i + \beta_2 AGE_i + \beta_3 MST_i + \beta_4 EDU_i + \beta_5 HHS_i + \beta_6 INC_i + \beta_7 PFW_i + \beta_8 PKR_i + \beta_9 \ln HAPP_i + \varepsilon_i \quad (25)$$

where

$FWD_i$  = Quantity of firewood bundle consume monthly.

$GEN_i$  = Gender of the head of household

$AGE_i$  = Age of the household head

$MST_i$  = Marital status of the head of household

$EDU_i$  = Level of education of the head of household

$HHS_i$  = Size of the household

$INC_i$  = Monthly income of the head of household

$PFW_i$  = Unit price of firewood per bundle

$PKR_i$  = Price of kerosene per liter

$HAPP_i$  = Number of home appliances own by household

---

## Analysis

This study mainly analyzes two issues: household energy switching and the extent of household traditional biomass energy use. Table 1 indicates the estimated ordered logit model analyzing the determinants of household energy switching. Furthermore, Table 2 exhibits the estimated OLS model for the determinants of household

**Table 1** Estimated coefficients of energy switching (ordered logit model)

Variables	Coefficients
Gender	0.7079 (0.5350)
Age	0.0233* (0.0126)
Education	0.0869** (0.0416)
Household size	-0.1148*** (0.0376)
Lnincome	0.0106*** (0.0040)
Location	0.6118* (0.3479)
Number of rooms	-0.0512 (0.0388)
Dwshare	-0.0075 (0.2634)
Hours of electricity supply	0.0149*** (0.0041)
Firewood price	0.0024 (0.0038)
Ncfuel	-1.2996*** (0.2905)
Home appliances	-0.0023 (0.0103)
Home ownership	0.6069** (0.2879) (1.124)
Observations	444
Pseudo R <sup>2</sup>	0.21

$$\chi^2(26) = 72.56$$

$$\text{Prob} > \chi^2 = 0.0000$$

Note: Robust standard errors in parentheses \*\*\*  $p < 0.01$ , \*\*  $p < 0.05$ , \*  $p < 0.1$

traditional biomass consumption. The analysis and discussions of the estimated models are carried out in the following sections:

## Determinants of Household Energy Switching

The first objective of this study is to assess the factors that determine the household movement along the energy ladder from traditional biomass energy to the available cleanest energy (electricity) in Bauchi State. To achieve this objective, ordered logit model was estimated and the result of the estimation is indicated in Table 1.

**Table 2** Determinants of household traditional biomass energy use

Variabes	Coefficients	Standard error
Gender	0.1190	(0.0834)
Age	0.0012	(0.0022)
Marital status	-0.1414**	(0.0598)
Education	-0.0078*	(0.0046)
Household size	0.0168***	(0.0041)
lnIncome	0.0382	(0.0420)
Price of firewood	-0.0030**	(0.0013)
Price of Kerosene	-0.0034***	(0.0010)
lnhappls	-0.262	(0.0496)
Constant	3.9106***	(0.241)
Observations	270	
R <sup>2</sup>	0.13	

Ramsey RESET Test (Specification test)

F(3, 244) = 5.63

Prob > F = 0.000

Note: Robust standard errors in parentheses\*\*\* p < 0.01, \*\* p < 0.05, \* p < 0.1

Based on the probability value of the Chi sq ( $X^2$ ), in Table 1, the estimated ordered logit model is jointly significant at 1%, thereby implying the validity of the estimated ordered model. The result indicates that the coefficient of variable Age is statistically significant at 10% level. The result indicates that there is a positive relationship between the age of the household head and the household energy switching. A 1 year increase in the age of the household will lead to a 0.023 log odd of household being in higher level of cleaner energy. This is in line with a priori expectation and conforms to the findings of Danlami (2017c). In the same vein, the coefficient of education was found to have a positive relationship with the household energy switching. The coefficient of the variable was found to be statistically significant at 5% level. The estimated result shows that an increase in the level of education of the household head increases the log odd of household switching to cleaner energy by about 0.087 units. This is in line with a priori expectation because when the household head is more educated, he will have more awareness about the negative effects of using traditional biomass energy. This result supports the findings from Danlami et al. (2018b).

Contrarily, the coefficient of household size was found to have a negative relationship with the household energy switching. This coefficient was found to be statistically significant at 1% level. Based on the estimated result, a one unit increase in the number of household size decreases the log odd of switching to cleaner energy by about 0.115 units. This is in line with the findings of Danlami et al. (2019c). The coefficient of household income was found to be statistically significant at 1% level. The estimated result indicates that a 1% rise in the household income leads to increase in the log odd of household switching to the cleaner energy by about 0.011 units. This is in line with a priori expectation because as the household income increases, the affordability of the household to substitute traditional biomass energy

with a cleaner energy increases. This supports the findings of Danlami (2017a). Similarly, the coefficient of household location was found to have a positive relationship with the household energy switching and it was found to be statistically significant at 10% level. Based on the result of the estimated ordered logit model, households that reside in urban areas of Bauchi State have higher log odd of switching to cleaner energy by about 0.612 units compared to their rural counterparts. This is in line with a priori expectations that the households living in urban areas adopt cleaner energy than the households living in the rural areas mainly due to economic, social, and educational factors. The exact fact is that cleaner sources of energy are more available in urban than in rural areas, which is in line with the findings of Danlami et al. (2018c).

The coefficient of hours of electricity supply was found to be statistically significant at 1% level and it was found to have a positive relationship with household energy switching. Based on the estimated model, 1 h increase in electricity supply increases the households' log odd of switching to cleaner energy by about 0.015 units. This conforms to a priori expectation that the tendency of households to move up the cleaner energy ladder increases when the electricity supply becomes more available and reliable. This supports the findings of Danlami et al. (2018b). Finally, the coefficient of home ownership was found to be statistically significant at 5% level. Based on the estimated ordered logit model, there is a positive relationship between the coefficient of home ownership and switching to cleaner energy in Bauchi State. The households that live in their self-owned home have higher log odd of switching to cleaner energy by about 0.607 units than otherwise. This is in line with the findings of previous studies (Danlami et al. 2018b)

## Determinants of Household Traditional Energy Use

Another objective of this study is to assess the factors that influence the quantity of traditional biomass energy use in Bauchi State, Nigeria. The result of the estimated model is in Table 2.

Based on Table 2, the estimated result shows that overall, the model is statistically significant at 1% level with an estimated F-value = 5.63 and the corresponding probability value  $\text{Prob}(F) = 0.000$ . The result in Table 2 has shown that the estimated coefficient of marital status is statistically significant at 5% level. On average, the households that are headed by a married person consume less traditional biomass energy by about 14% lower compared to the households that are headed by a nonmarried person. This does not conform to a priori expectation because the expectation is that when the head of a household is married, it means more number of household members which necessitates the use of more traditional biomass fuel such as firewood. However, this may be because the married household head in some cases signifies that he is at least more economically stronger to buy cleaner fuel than firewood. Based on the culture of the people in the study area, a person usually married when economically can afford the marriage responsibilities of which the

purchase of cooking fuel is among. This finding supports the findings of other previous studies (Danlami 2019).

Moreover, the coefficient of level of education of the household was also found to be negative and statistically significant at 10% level. Based on the estimated OLS model, an additional year in the level of education reduces the household's use of traditional biomass energy by about 0.78%. This conforms to a priori expectation that as more educated is the household head, the more he has health consciousness and also the more he knows the risk of using traditional biomass energy thereby minimizing the use of such energy. This is in line with the findings of Danlami (2017a) and Lee (2013). On the other hand, the coefficient of household size was found to be statistically significant at 1% and positively related to household use of traditional biomass energy. Based on the result shown in Table 2, increase in the number of household by one individual increases the household's use of traditional biomass energy by about 1.68%. This conforms to a priori expectation and is in line with the findings of previous studies (Danlami 2017a).

The result also indicates that there is a negative significant relationship between traditional biomass energy use and its price. A one Naira increase in the price of firewood decreases the rate of household traditional biomass energy use by about 0.3% all things being equal. This is tally with a priori expectation because as the price of the traditional biomass energy increases, the household will switch to the use of available cheaper and cleaner energy. Similarly, when the price of a commodity rises, the purchasing power of buyers decreases, leaving the consumer with the ability to buy less of that commodity. This finding is in line with traditional law of demand which says that the higher the price, the lower the quantity demanded and also supports the findings of. Lastly, the result shows that price of kerosene has a negative impact on traditional biomass energy.

---

## Conclusions

This study analyzes household energy switching along the energy ladder using ordered logit model. Also, the study uses OLS regression model to analyze the determinants of household traditional biomass energy use. The age of the household head and his level of education, income, living in urban areas, home ownership, and hours of electricity supply have positive significant impact on household energy switching from traditional biomass energy use to the cleaner energy. On the other hand, household size was found to have a negative relationship with household energy switching. Furthermore, the estimated OLS model indicates that household size has a positive and significant impact on traditional biomass energy use, the higher the household size, the high the quantity of traditional biomass energy consumption all things being equal. Marital status, household head level of education, and the price of the traditional biomass energy have negative significant impact on household use of traditional biomass energy.

## Policy Recommendations

Having conducted empirical investigation of household energy switching and traditional energy consumption in Bauchi State, Nigeria, the following recommendations were offered based on the study findings, in order to encourage households to switch to cleaner energy in the study area. Since increase in income was found to have significant impact in encouraging households' energy switching up to cleaner energy, policies and programs aimed at raising income earnings of individuals should be embarked upon to discourage the adoption and use of traditional biomass energy. Income can be increased via employment generation, wealth creation, increase in government expenditure, empowering small and medium scale industries, and skills acquisition and development programs.

The study finds that households that live in urban areas have higher probability and odd of switching to cleaner energy. In line with this finding, government should try to make cleaner energy available and affordable to rural dwellers as is in the urban areas. All the facilities that will ensure the availability of cheap cleaner energy in rural areas of the State should be established in order to encourage households to switch to cleaner energy in rural areas of the State.

The findings revealed that the level of formal education attainment by the household head has significant influence on switching to cleaner energy, the higher the level of education of the household head, the higher the odd of switching to the cleaner energy. Therefore, government should embarked upon policies to encourage higher education attainment of people leaving in the study area, especially rural areas whereby there are a large number of illiterate people. High rate of school enrolment can be increased via policies like free universal basic education programs, higher education enrolment at a subsidized rate, construction of more schools near to the people especially in rural areas, provision of more scholarships at higher levels, employing adequate number of teachers to meet the growing number of pupils, and increase in expenditure on educational facilities. The curriculum of the educational system should emphasize on the danger of high rate of environmental pollution and contamination especially in rural areas whereby the rate of awareness is very low.

Lastly, the study has found that adequate supply of electricity has significant impact on household switching to cleaner energy use. Therefore, provision of cheap and adequate electricity supply to households will encourage many households to use electricity as their main source of cooking and lighting, thereby reducing the rate of traditional biomass energy use.

---

## References

- Abdurrazak NTA, Medayese SO, Martins VI, Idowu OO, Adeleye BM, Bello LO (2012) An appraisal of household domestic energy consumption in Minna, Nigeria. *J Environ Sci Toxicol Food Technol* 2:16–24
- Couture S, Garcia S, Reynaud A (2012) Household energy choices and fuelwood consumption: an econometric approach using French data. *Energy Econ* 34:1972–1981



- Danlami AH (2014) Examination of determinants of demand for Fertiliser in Tofa local government area, Kano State. *Niger J Manag Technol Dev* 5(2):1–14
- Danlami AH (2017a) An analysis of household energy choice and consumption in Bauchi State, Nigeria [thesis]. School of Economics Finance and Banking: Universiti Utara Malaysia
- Danlami AH (2017b) Determinants of household electricity consumption in Bauchi State, Nigeria. *Hyper Econ J* 5(1):16–28
- Danlami AH (2017c) An intensity of household kerosene use in Bauchi State, Nigeria: a tobit analysi. *Niger J Manag Technol Dev* 8(2):1–13
- Danlami AH (2019) Assessment of factors influencing firewood consumption in Bauchi State, Nigeria. *J Sustain Sci Manag* 14(1):99–109
- Danlami AH, Islam R (2020) Explorative analysis of household energy consumption in Bauchi State, Nigeria. In: Editor A (ed) *Energy efficiency and sustainable lighting – a bet for the future*. IntechOpen, London
- Danlami AH, Islam R, Applanaidu SD (2015) An analysis of the determinants of household energy choice: a search for conceptual framework. *Int J Energy Econ Policy* 5(1):197–205
- Danlami AH, Islam R, Applanaidu SD, Tsauni AM (2016) An empirical analysis of fertiliser use intensity in rural Sub-Saharan Africa: evidence from Tofa local government area, Kano State, Nigeria. *Int J Soc Econ* 43(12):1400–1419
- Danlami AH, Applanaidu SD, Islam R (2017) From biomass cooking fuel source to modern alternative for Bauchi State households: a preliminary analysis. *Biofuels* 8(3):323–331
- Danlami AH, Applanaidu SD, Islam R (2018a) Movement towards a low carbon emitted environment: a test of some factors in Malaysia. *Environ Dev Sustain* 20(3):1085–1102
- Danlami AH, Applanaidu SD, Islam R (2018b) An analysis of household cooking fuel choice: a case of Bauchi State, Nigeria. *Int J Energy Sector Manag* 12(2):265–283
- Danlami AH, Applanaidu SD, Islam R (2018c) Axiom of the relative income hypothesis and household energy choice and consumption in developing areas: empirical evidence using Verme model. *Kasetsart J Soc Sci* 39:422–431
- Danlami AH, Aliyu S, Danmaraya IA (2019a) Energy production, carbon emissions and economic growth in lower-middle income countries. *Int J Soc Econ* 46(1):97–115
- Danlami AH, Applanaidu SD, Islam R (2019b) A micro level analysis of the adoption and efficiency of modern farm inputs use in rural areas of Kano State, Nigeria. *Agric Res* 8(3):392–402
- Danlami AH, Applanaidu SD, Islam R (2019c) Movement towards the adoption of non-traditional household lighting fuel energy in developing areas. *Biofuels* 10(5):623–633
- Desalu O, Ojo O, Aritibi E, Kolawale F, Idowu A (2012) A community survey of the pattern and determinants of household sources of energy for cooking in rural and urban South Western, Nigeria. *Pan Afr Med Res J* 2:1–12
- Dillman DA (2011) *Mail and internet surveys: the tailored design method 2007 update with new internet, visual, and mixed-mode guide*. Hoboken, Wiley
- Eakins J (2013) An analysis of the determinants of household energy expenditures: empirical evidence from the Irish household budget survey. PhD thesis, University of Surrey
- Ganchimeg G, Havrland B (2011) Economic analysis of household energy consumption: the case of herders in Mongolia. *Agric Trop Subtrop* 44:197–203
- Heltberg R (2005) Factors determining household fuel choice in Guatemala. *Environ Dev Econ* 10: 337–361
- International Energy Agency (IEA) (2011) *Energy balances of non-OECD countries*. IEA, Paris
- Jingchao Z, Kotani K (2011) The determinants of household energy demand in rural Beijing: can environmentally friendly technologies be effective? *Energy Econ* 34:381–388
- Jumbe BLC, Angelsen A (2010) Modeling choice of fuelwood source among rural households in Malawi: a multinomial probit analysis. *Energy Econ* 33:732–738
- Kofarmata YI (2016) An economic analysis of participation in credit market and credit rationing among farmers in Kano State, Nigeria [thesis]. School of Economics Finance and Banking, Universiti Utara Malaysia
- Laureti T, Secondi L (2012) Determinants of households' space heating type and expenditures in Italy. *Int J Environ Res* 6(4):1025–1038

- Lee LY (2013) Household energy mix in Uganda. *Energy Econ* 39:252–261
- Mensah T, Adu G (2013) An empirical analysis of household energy choice in Ghana. Uppsala working paper series no 6
- Naibbi AI, Healey RG (2013) Northern Nigeria's dependence on fuelwood: insights from nationwide cooking fuel distribution data. *Int J Humanit Soc Sci* 3:160–173
- NBS (2012) Annual abstract: federal republic of Nigeria. Retrieved February, 2016 from: <http://www.nigerianstat.gov.ng>
- Nlom JH, Karimov AA (2014) Modeling fuel choice among households in Northern Cameroon. WIDER working paper series, 2014/038.45
- Nnaji C, Ukwueze E, Chukwu J (2012) Determinants of household energy choices for cooking in rural areas: evidence from Enugu State, Nigeria. *Cont J Soc Sci* 5(2):1–11
- Ogwumike FO, Ozughalu UM, Abiona GA (2014) Household energy use and determinants: evidence from Nigeria. *Int J Energy Econ Policy* 4(2):248–262
- Onoja AO (2012) Econometric analysis of factors influencing fuel wood demand in rural and Peri-urban farm households of Kogi State. *J Sustain Dev* 8(1):115–127
- Osiolo HH (2010) Enhancing household fuel choice and substitution in Kenya. Kenya Institute for Public Policy Research, Nairobi
- Oyekale A, Dare A, Olugbire O (2012) Assessment of rural households' cooking energy choice during kerosene subsidy in Nigeria: a case study of Oluyole local government area of Oyo State, Nigeria. *Afr J Agric Res* 7:5405–5411
- Özcan KM, Gülay E, Üçdoğruk S (2013) Economic and demographic determinants of household energy use in Turkey. *Energy Policy* 60:550–557
- Risseeuw N (2012) Household energy in Mozambique: a study on the socioeconomic and cultural determinants of stove and fuel transitions. Unpublished Master's thesis, Vrije University, Amsterdam
- Song N, Arguilar FX, Shifley SR, Goerndt ME (2012) Factors affecting wood energy consumption by U.S. households. *Energy Econ* 34:389–397
- Suliman MK (2010) Factors affecting the choice of households' primary cooking fuel in Sudan. Research report presented to the Economic Research Forum, Cairo
- Tchereni BH (2013) A microeconomic analysis of energy choice behaviour in South Lunzu Township, Malawi. *Mediterr J Soc Sci* 4(6):569–578
- UNDP (2013) Human development report: Nigeria. Retrieved 22 November, 2014 from <http://resource.dat.com/wp-content/uploads/2013/05/Nigeria-HDI-value>
- Yamamoto S, Sie A, Sauerborn R (2009) Cooking fuels and the push for cleaner alternatives: a case study from Burkina Faso. *Glob Health Action* 2:156–164

**Open Access** This chapter is licensed under the terms of the Creative Commons Attribution 4.0 International License (<http://creativecommons.org/licenses/by/4.0/>), which permits use, sharing, adaptation, distribution and reproduction in any medium or format, as long as you give appropriate credit to the original author(s) and the source, provide a link to the Creative Commons license and indicate if changes were made.

The images or other third party material in this chapter are included in the chapter's Creative Commons license, unless indicated otherwise in a credit line to the material. If material is not included in the chapter's Creative Commons license and your intended use is not permitted by statutory regulation or exceeds the permitted use, you will need to obtain permission directly from the copyright holder.





# Resetting the African Smallholder Farming System: Potentials to Cope with Climate Change **70**

Bernhard Freyer and Jim Bingen

## Contents

Introduction .....	1442
CCAM Practices and Barriers for Their Implementation .....	1444
Crop Diversity and Crop Rotations .....	1444
Mulching Strategies and Green Manure Cover Crops .....	1446
Farm Yard Manure .....	1448
Soil Tillage .....	1449
Agroforestry .....	1450
(Silvo-) Pastoral Systems .....	1450
Impact of Arable and Plant Cultivation Methods on pH Regulation .....	1451
Cattle, Dairy, Sheep, and Goat Systems .....	1452
Agricultural Production Systems Contributions to CCAM .....	1452
Sustainable Intensification – Some Terminological Clarifications .....	1452
Conservation Agriculture .....	1454
Organic Farming .....	1455

---

This chapter was previously published non-open access with exclusive rights reserved by the Publisher. It has been changed retrospectively to open access under a CC BY 4.0 license and the copyright holder is “The Author(s)”. For further details, please see the license information at the end of the chapter.

---

B. Freyer (✉)

Division of Organic Farming, University of Natural Resources and Life Sciences (BOKU), Vienna, Austria

e-mail: [bernhard.freyer@boku.ac.at](mailto:bernhard.freyer@boku.ac.at)

J. Bingen

Michigan State University (MSU), East Lansing, MI, USA

e-mail: [bingen@msu.edu](mailto:bingen@msu.edu)

© The Author(s) 2021

W. Leal Filho et al. (eds.), *African Handbook of Climate Change Adaptation*,  
[https://doi.org/10.1007/978-3-030-45106-6\\_267](https://doi.org/10.1007/978-3-030-45106-6_267)

1441

Discussion .....	1456
The Logic of CCAM Practices .....	1456
Barriers for Adoption CCAM from a Production Perspective .....	1457
Markets, Policies, and Education for a Diversified Production .....	1459
Conclusions .....	1460
References .....	1461

---

### Abstract

Agricultural production systems, for example, conservation agriculture, climate smart agriculture, organic agriculture, sustainable landuse management, and others, summarized under the term “sustainable intensification,” have been introduced in African countries to increase productivity and to adapt/mitigate CC (CCAM). But the productivity of smallholder farming systems in Africa remains low. High erosion, contaminated water, threatened human health, reduced soil water, and natural resources functionality, that is, ecosystems services, and decreased biodiversity dominate. Low support in the farm environment is also responsible for this situation.

It is hypothesized, based on the huge body of literature on CCAM, that the implementation of already existing arable and plant cultivation methods like crop diversity, alley crops, forage legume-based crop rotations, mulching, organic matter recycling, and reduced tillage intensity will increase CCAM performance and also farm productivity and income. Based on a brief analysis of CCAM relevant arable and plant cultivation methods and agricultural production systems potentials and challenges, this chapter offers guidance for further transforming climate robust African farming systems.

---

### Keywords

Agricultural production systems · Arable and plant cultivation methods · Climate change adaptation and mitigation · Institutional environment · Smallholder farmers practices in Africa

---

## Introduction

In this brief review, the discussion focuses on factors making smallholder farmers vulnerable to CC induced drought and floods and how they are able to cope with CC. The chapter refers to the farms internal management, the relevance of the diverse arable, and plant cultivation methods that are differently organized and highlighted in today’s agricultural production systems, which might contribute to adapt/mitigate climate change (CCAM), and how the institutional environment impacts a farmer’s capacity to apply CCAM.

This chapter summarizes contributions to CCAM with reference to the diverse mixed farming systems in East Africa. This region is so far of interest as it entails a broad range of African farming systems. Those farming systems with an annual rainfall between approx. 800 mm and 2.000 mm, annual or bi-annual rainfall

patterns, and farm sizes between approx. 0.5 and 2.0 ha have been selected. With that the study excludes farming systems from mainly drought regions that however are asking for partly different farming solutions, which would open an additional chapter to discuss. So far, the review will offer a part of the whole picture on farm internal management strategies and relevant environmental (institutional) conditions specifically under East African conditions.

There is evidence that specifically Africans agricultural systems are challenged by climate change (IPCC 2018). To reach the SDG2 targets in the next decade, investment costs to reduce hunger in Africa for the next decade are tremendous (Mason-D'Croz et al. 2019). Such future pictures are based on mainstream agricultural practices, combined with all kinds of single agricultural practices, borrowed from latest discussed agricultural production systems (Gonzalez-Sanchez et al. 2019; Porter et al. 2019; Senyolo et al. 2018; Zougmore et al. 2018).

The hypothesis, which is framing the analysis, argues that the systemic implementation of already existing arable and plant cultivation methods like crop diversity, alley crops, forage legume-based crop rotations, mulching, organic matter recycling, and reduced tillage intensity will increase CCAM performance and also farm productivity, and as a consequence also the income. The majority of recommendations to cope with CC on smallholder farms commonly involve single methods, such as diversified crop rotations, intercropping, relay cropping, alley cropping and silvo-pastoral systems, compost and manure management, pH regulation, mulching, and low tillage intensity. These methods are summarized as arable and plant cultivation methods, but are also discussed as “agroecological” methods. If properly managed, these methods can increase biodiversity and biomass production; close carbon and nutrient cycles, as well as optimize mineralization processes and increase carbon sequestration; decrease soil erosion; and optimize regulation of the micro- and mesoclimate and the water household. They can also be classified as the backbone of sustainable production, and as such, operate as ecosystems services. The single methods (crop rotation, mulching, . . .) arise in different combinations and partly different “accentuations,” in specific agricultural production methods described with the terms “climate smart agriculture, sustainable landuse management, or organic agriculture” and summarized under the term sustainable intensification.

Literature corpus on this topic is huge. Most of the methods are mentioned in the latest report on CC (The IPCC' Special Report on Climate Change and Land. What's in it for Africa? (Dupar 2019 #156). But what is missing in this report is a systemic view and integration of the diverse practices that would make farming systems robust against CC. In other words, to clearly indicate that adoption of farming systems is no longer the adequate reaction on the dramatic situation driven by CC. Instead, there is need for a huge transformation of farming systems as a whole.

For discussing the hypothesis, a selection of reviews and empirical studies seems adequate, using the terminology of arable and plant cultivation, that is, agroecology methods, and selected agricultural production systems (e.g., climate smart agriculture, conservation agriculture and others) within the context of CCAM as key words. Main literature was selected between the years 2010 and 2020 by Google scholar

including reviewed papers and grey literature (Majumder 2015), to make visible how far in the last decade, where conservation agriculture, climate smart agriculture, agroecology, or sustainable intensification became prominent in the debate, CCAM was discussed. There are some exceptions, where identified literature informed about earlier relevant sources. Using cropping systems as an example, for all sections with a specific topic, search was defined as follows: Smallholder farming AND cropping systems AND Climate change AND Africa/Review AND Smallholder farming AND cropping systems AND Climate change AND Africa. Following a stepwise saturation in a certain field of knowledge, that is, explicit, reproducible, and leads to minimum bias, further papers that indicate mainly same messages have been excluded (Grant and Booth 2009).

A quantification of applied CCAM is critical due to the fact that there is huge diversity of agroecological conditions and farming practices and that there is no empirical basis available for making such an assessment. Instead, a qualitative assessment of the impact of CCAM methods is applied to primarily understand specific characteristics in their context (see the methodological approach chosen by Dale 2010). For that a set of methods both single arable and plant cultivation methods as well the agricultural production systems have been selected that are well known to be relevant for CCAM.

---

## CCAM Practices and Barriers for Their Implementation

This section reviews the most relevant single methods, their potential to contribute to CCAM, and farm productivity, and the barriers that hinder farmers from implementing them are discussed. Drought adapted varieties, irrigation, and water management technologies are not mentioned specifically. It is assumed that they are part of any CCAM approach.

### Crop Diversity and Crop Rotations

In many farming systems, crop diversity in crop rotations is low. Currently, maize is the dominant crop in most crop rotations in Africa. The other land is planted mainly with cereals, grain legumes, and root crops and in some cases intercropped maize and grain legumes (Table 1) (Rusinamhodzi et al. 2012). These one-sided systems, with open soils with low root (< 1 t DM ha<sup>-1</sup> a<sup>-1</sup>) and above ground biomass (< 2 t DM ha<sup>-1</sup> a<sup>-1</sup>), lead to highly vulnerable soils over the whole African continent, continuously losing fertile soils and the capacity to store water and nutrients. The key crops for moving to higher CCAM relevant ecological functions of cropping systems are forage legumes and forage-grain legumes with high root (> 2 t DM ha<sup>-1</sup> a<sup>-1</sup>) and above ground biomass (> 4 t DM ha<sup>-1</sup> a<sup>-1</sup>) that currently can only be found in some selected regions in pure stands or in combination with maize, known as push and pull system. The latter is a combination of Maize with undersown/intercropped

**Table 1** CCAM relevant ecological functions of crops and cropping systems

Ecological functions	Crops									
	Maize <sup>a</sup>	Other cereals <sup>a</sup>	Sorghum <sup>a</sup>	Potatoes	Cassava	Grain legumes <sup>a</sup>	Forage grain legumes <sup>b</sup>	Forage legumes <sup>c</sup>		
Soil erosion control	+	++	++	+	+	+	++	+++		
Carbon sequestration (humus production)	+	+	++	+	+	+	++	+++		
Nitrogen fixation	/	/	/	/	/	+	++	+++		
Local climate regulation	+	+	++	+	+	+	++	++		
Water infiltration/avoidance of water run-off	+	++	++	+	+	+	++	+++		
Water holding capacity	+	+	++	+	+	+	++	+++		

Source: Authors compilation

+ = low; ++ = medium; +++ = high; / = not applicable; - = indicating intermediate position

<sup>a</sup>intercropping of cereals and grain legumes would increase the ecological functions of both crop groups with values between grain legumes and forage grain legumes

<sup>b</sup>crops with high biomass and grain production (e.g., cow pea, grass pea, lablab, mucuna, mung bean)

<sup>c</sup>alfalfa, centrosema, clover, desmodium, and others

desmodium and Napier grass as a trap crop to control stemborer and striga, a chemical ecology-based integrated pest management technology (Khan et al. 2016).

The transformation of cropping systems towards forage legume-based systems can increase the potential of CCAM (Forage legumes > Forage grain legumes > Intercropping systems), through relatively high below (3–6 t DM ha<sup>-1</sup> a<sup>-1</sup>) and above ground biomass (5–15 t DM ha<sup>-1</sup> a<sup>-1</sup>) and nitrogen fixation (50–300 kg N ha<sup>-1</sup> a<sup>-1</sup>) of forage legumes (Kumar et al. 2018), efficiently reducing soil erosion (Sheaffer and Seguin 2003) and with positive impact on following cash crop yields (Traill et al. 2018). Nutrient acquisition and nutrient utilization are species and genotype specific and differ between crop families of grasses and legumes and between legumes (Gómez-Carabali et al. 2010). Of relevance is the % lignin, C:N ratio, (lignin + polyphenol): N and C-to-N ratios (Thomas and Asakawa 1993). Evidence is also given that this crop group increases animal performance, where similarly the mentioned ratios are of relevance for the digestibility of forage legume feed (Schultze-Kraft et al. 2018).

The implementation of this crop group however is challenging for several reasons: the availability of seed material; the lack of knowledge about the potential impact of plant based nitrogen on the following crop performance; the idea that humans cannot eat forage legumes, and therefore cropping forage is a short-term loss of land for assuring food security, but one that overlooks the contribution of farm yard manure to increased crop yields as well as to the production of milk and meat.

It appears that forage legumes are not offered by either seed breeders, seed wholesalers, advisory services or researchers and policies, with some exceptions of selected species and regions. In the same way, farmers multiplication of seed material is an exception. The diversification of crop rotations with nonmainstream crops is limited because there is no demand by the markets, but also because of traditional food habits. Intercropping and relay cropping – two submethods of crop rotations – likewise can increase yield and income and are rarely implemented.

## Mulching Strategies and Green Manure Cover Crops

It is commonly argued that mulch material contributes significantly to the ecological functions and CCAM (Table 2). Already small amounts of mulch material positively impact soil parameters (Mchunu et al. 2011). However, most smallholder farms have no left-over organic matter from their arable fields. All the straw and weeds are consumed by animals after harvest, or burned. As a result, soils are open and this contributes to a further loss of the first most fertile millimeter of humus via wind and water erosion, and leads to a continuous reduction of soil functions. Collecting mulch material outside the farm is for several reasons not a sustainable approach. First, in many regions, biomass is limited, but also requires significant labor, estimated to be 5 to 12 days per acre (Bunch 2017). Furthermore, it does not fit for a community or catchment approach if all farmers would collect biomass, competing also the feed demand of grazing animals, that are mainly far beyond



**Table 2** CCAM relevant ecological functions of agroecological practices

Ecological functions	Agroecological methods (arable and plant cultivation methods)					
	Mulching systems	Green manure cover crops	Farm yard manure types <sup>a</sup>	Low tillage systems	Agro-forestry systems	Silvo-pastoral systems
Soil erosion control	+++	+++	+ – +++	+ – ++ +	+++	+++
Carbon sequestration (humus production)	+ – ++	+++	+ – ++	/	+++	+++
Reduction of soil compaction	++	+++	++	+	+++	+++
Nitrogen fixation	/	/–+++	/	/	+++	+++
Local climate regulation	+ – ++	+ – ++	/	+ – ++	+++	+++
Water infiltration, i.e., avoidance of water run of	+++	+++	++	+++	+++	+++
Water holding capacity	++	+++	++	+++	+++	+++
pH-regulation/ increase of nutrient availability	+++	+++	+++	+	+++	+++
Nutrient/carbon recycling			+++	/		
• Spatial (field)					+++	
• Temporal (years)	+++	+++			+++	
• Horizontal (soil layer)	+++	+++			+++	+++

Source: Authors compilation

+ = low; ++ = medium; +++ = high; /=not applicable; – = indicating intermediate position a including a broad range of types from stable manure up to liquid forms

the carrying capacity of the communities available pasture land (Wall 2017). Further relevant source for mulch material is branches from alley crops with an annual biomass productivity of 2 to 10 t DM ha<sup>-1</sup>, dependent on the tree species, variety, as well as the planting density and well-managed ratooning (Wilson et al. 1986).

Green manure cover crops are mainly planted in the short rainy season and used also for food and feed purposes. Green manure cover crops (GMCC) include any species of plant, mainly leguminous crops, whether it is a tree, a bush, a climbing vine, a crawler, a grain legume, forage-grain legumes, or close to water a water born plant (Wall 2017). GMCC like Lablab beans (*Dolichos lablab* or *Lablab purpureum*), runner beans (*Phaseolus coccineus*), mucuna (*Mucuna spp.*), ratooned pigeon peas (*Cajanus cajan*), jack beans (*Canavalia ensiformis*), and many other GMCC species like tephrosia (*Tephrosia vogelii* or *T. candida*) produce high

amounts of biomass and increase C-sequestration (above and below ground biomass) (Branca et al. 2013; Hobbs and Govaerts 2010). Nitrogen fixation of leguminous crops varies in a broad range of approx. 80 and 250 kg N ha<sup>-1</sup> a<sup>-1</sup>, according to species, variety, soil and climatic conditions, and crop management (Monegat 1991). Assuming a loss of 50% via volatilization and use of grains (Bunch 2017), there are still more than 40 kg ha<sup>-1</sup> a<sup>-1</sup> N for the following crop with a reference value of 2 t ha<sup>-1</sup> a<sup>-1</sup> wheat.

Seriously managed, CMCC, combined with minimum soil tillage, can reduce soil erosion by more than 90% (equivalent to a means of 850 kg ha<sup>-1</sup> organic matter, approximately 50 kg nitrogen ha<sup>-1</sup> and 8 kg phosphorus ha<sup>-1</sup>). GMCC provides nitrogen and offers weed control (Elwell and Stocking 1988), as well as other benefits, including the amelioration soil compacted (Scopel et al. 2004). But GMCC for compost or mulch is only partly a solution because farmers argue that all land should be used for food production, and this hinders them from investing in these crops, which asks for an answer. With forage grain legumes, an alternative exists that can fulfill both ecological functions, but also offer food and feed, and keep relevant parts of the fixed nitrogen in the field. Barriers to their implementation are costs (seeds) and lost harvest of a catch crop income. So, farmers often prefer intercropping of, or rotation with, grain legume crops rather than GMCC (Nandwa et al. 2011).

## Farm Yard Manure

Farm yard manure (FYM), which is an un-normed mixture of dung, slurry, straw, and feed residues, is an organic material with many relevant ecological functions (Table 2) (Teenstra et al. 2015). FYM is potentially available on a farm for re-distribution to the fields, if there is any form of zero grazing or animals fenced for certain times in a kraal. Systematically applied, FYM manure can increase biomass production by 100% (Ndambi et al. 2019). In many cases, its impact on yields is comparable with that of medium mineral fertilizer inputs; or the combination of 5 t ha<sup>-1</sup> FYM with 30 kg N ha<sup>-1</sup> a<sup>-1</sup> is able to produce equivalent maize yields in comparison with 200 kg N ha<sup>-1</sup> a<sup>-1</sup> (Achieng et al. 2010).

Practically each smallholder farm should have some FYM. One ox, one or two cows, and in some cases approx. Five sheep or goats and 10–20 chickens are a classical set of animals for a 1 ha farm. A tropical livestock unit is calculated with 250 kg, which is 50% of the Western standard. Additional feed comes from communal pastures, feed along pathways, and from shrubs. Milk productivity with this feed is rather low (378.6 kg cow a<sup>-1</sup> in 2018 in East Africa; <http://www.fao.org/faostat/en/#data/QL>). As a result, the production of farm yard manure is low as well as their nutrient content. Moreover, this limited manure production is often used for house construction or for cooking purposes. In addition, most farmers do not apply manure management practices, such as roofed animal housing, with water-proof floor or covering manure during storage in order to prevent large nutrient losses during manure storage, increasing greenhouse gas emissions, and reducing the

quality of the manure as a fertilizer and its positive impacts on ecological factors, that is, contributions to CCAM (Ndambi et al. 2019).

To conclude, farm yard manure contribution in current smallholder systems to strengthen CCAM or productivity is seriously low or nonexistent. Hurdles for an adequate collection and use of FYM are lack of knowledge in general about the value of this organic matter, techniques for cut and carry feed, investment for zero grazing units, that is, kraal fencing, and techniques for the adequate distribution of the manure in the field. Furthermore, it seems neither in the focus of advisory services nor of research or policy agendas (ibid).

## Soil Tillage

Soil tillage functions include, among others, to loosen the soil, to provide technical aid for in depth growth of roots, to homogeneously mix organic matter with the soil, and to prepare seed beds.

Current partly excessive soil tillage systems often lead to soil compaction, soil aggregate break down, soil dust, and rapidly decomposing organic matter. High rates of topsoil loss contribute to downstream sedimentation and degradation of local and regional water bodies (Tully et al. 2015). While soil compaction reduces the seedbed quality and thus hinders the germination of seeds, soil dust gets irreversibly lost via water and wind erosion. Thus, the current type of so-called plowing tillage systems in combination with maize dominated cropping systems weakens several ecological functions relevant for CCAM.

In general soil tillage systems follow a continuum from conventional inversion moldboard plow up to disc opener no-till planter into dead residue (Reicosky 2015). Alternative soil tillage systems have been developed over the years to reduce tillage intensity, including stubble mulching, to reduce or eliminate tillage, and to retain plant residue on the soil surface to alleviate wind and water erosion. These practices led to what became known as conservation tillage, culminating in no-till systems that avoid any soil disturbance. No-tillage, reduced-tillage, mulch-tillage, and strip-tillage are some of the diverse CA tillage approaches.

The combination of green mulch cover crops (GMCC) is expected to significantly increase ecological functions and contributions towards CCAM (Table 2). GMCCs can also control weeds by covering, that is, suppressing upcoming weeds. Potential yields through combining mulching and low soil tillage exceed 100%. But it must be remembered that the quantity of additional organic carbon in the soil under no-till is relatively small. The main effects are relevant for other ecological functions and indirectly contribute to CCAM. Over the years it also has become evident, that after a period of low tillage interventions, this system must be interrupted for 1 year with a more intense tillage approach, in order to loosen natural soil compaction effects in the below ground, as well as to regulate the weed pressure (Powelson et al. 2014).

Soil tillage systems technologies with reduced intensity are only available in some regions and the optimal approach which depends on soil type, rainfall, share of skeleton, precrop and the following crop, as well as above ground biomass is still not

identified for many agroecological situations. If not managed properly, nonadequate technique applied, and rotations without forage legumes, as well as limited or lack of mulch material, there is high risk of weed pressure, reduced crop yields. If weeds take over farmers then tend to misinterpret the approach increasing the application of fertilizer inputs and herbicides with negative environmental impact (Giller et al. 2011). A certain number of weeds however can provide also positive ecological functions, as discussed in OA (Hillocks 1998). Missing finances for the technical equipment and knowledge gaps might be other reasons for low adaptation rates of reduced tillage systems in Africa.

## Agroforestry

The multifunctions of the diverse agroforestry systems are highly relevant for CCAM (Lasco et al. 2014), but also serve as forage or for other diverse purposes (fuel, construction, apiculture, food, forage), and provide positive contributions to reduce concentration of carbon dioxide (CO<sub>2</sub>) and other greenhouse gases (GHGs) (Awazi and Tchamba 2019) and to regulate microclimate (Mbow et al. 2014). Specifically, alley-crop-systems contribute to multiple ecological functions (Table 2). They contribute to a reduction of inorganic inputs (Wilkins 2008), to pest and disease control (Murthy et al. 2013), biodiversity (Murthy et al. 2016), and regulation of microclimate (Schroth et al. 1995). What makes them specifically attractive is their use of subsoil layer nutrients and water resources and photosynthesis above the main crops, well adapted to soil and climate conditions, simulating partly the original vegetation cover before once turned the land from natural forest to arable land.

Alley branches can be used directly as mulch, or as a protein feed for animals, filling the protein gap and leading to higher animal manure production. Trials of alley crops with rows all 4–8 m document the high positive impact on cash crop growth. A weakness in the majority of trials are monocropping alleys with an increased risk of pest and diseases, while diverse alley crops provide more resistance, multiple functions for arable pest and disease control, and a diversification of forage qualities and adaptability towards CC (e.g., *Faidherbia* spp.).

On smallholder farms, their integration is challenged if the land is scattered. Otherwise, already the limited area of the homestead would offer space for implementation. Biomass productive hedges are often not in place and also the technique of ratooning, for example, in case of pigeon pea, and other management practices are missing and are limited in biomass production with all its positive impact on CCAM. Further hurdles for smallholder farmers to integrate a diverse cropping scheme with alley crops are the limited availability of seedlings, lack of knowledge how to prune shrubs and to integrate into feed ratios, as well as investment costs and workload for their management.

## (Silvo-) Pastoral Systems

Pastoral systems are usually the backbone of animal systems. By nature, grassland is rich in root biomass and humus content is seriously higher than in arable systems

with permanent soil tillage. However, in most African countries, pastures are overused, sward management is low, erosion is high, and productivity is not high enough to feed animals with energy and protein rich crops. Irreversible loss of land via erosive processes/land-slides is point on the agenda explaining the critical situation (Wynants et al. 2019). Land distribution and ownership patterns coupled with continuous fragmentations are further drivers of the current system and are challenging farmer towards sustainable grassland management (Tesfa and Mekuriaw 2014). Provision towards ecological functions, that is, contributions towards CCAM, is low if not negative.

Limited availability of seeds, lack of labor for establishing pasture systems, the cost of fencing and knowledge gaps, as well as missing management and knowledge at community level, as well as missing management at the community level, hinder and limit the production of pasture biomass and thus also their CCAM.

As an alternative silvopastoral system, a combination of pastures with leguminous shrubs and trees provide relevant contributions to ecological functions towards CCAM (Table 2) and an enormous increase of biomass production (Sarvade et al. 2019). The forage legume trees cover a high share of the protein gap limiting the animal production. Forage production can be seriously increased with a strong impact on the level of fattening and milk production and less GHG emissions per animal unit (Broom et al. 2013). For that grassland management needs to reorganize, including regulations for use, awareness on traditions, and fenced or otherwise controlled areas (Ochieng and Waiswa 2019).

## Impact of Arable and Plant Cultivation Methods on pH Regulation

The pH of soils with substantial ecological functions and specifically high impact on biomass production is influenced by several of the arable and plant cultivation methods and therefore is summarized in this subsection. The pH of many East African soils is below 5.0, virtually no available phosphorus and toxic levels of aluminum (Bunch 2017) and therefore out of the optimum for a productive crop growth and biomass production, which is between 5.8 and 6.5, while crop specific in a broader range. Mineralization processes, the optimal living conditions for microorganisms responsible for many soil functions, and growth conditions for crops are limited with low pH, leading to lower crop yields, that is, less positive impact on CCAM. Under acid soil conditions, phosphorous is tied up in a short time and does not provide more than 0.5% soil phosphorous in forms that are available to plants. The general low P content of African soils increases the dilemma.

Mulch and compost material mainly from grass provide a large C/N and therefore will not feed the crops. A high share of legumes instead offers a C/N which boosts the growth of microorganism that are functioning as storage but also deliver nutrients towards crops through the decomposition of mulch material. Phosphorous becomes available as a slow floating source. Farm yard manure (approx. pH 7), slurry (approx. pH 8), and compost (approx. > 7 pH) with high pH values would positively influence nutrient availability and thus crop productivity. Current systems are lacking these effects due to the low availability of manure, slurry, and compost,

which at least causes the inefficient land use and low productivity of crop and animal production. Also, alley crops have the potential to increase the pH via litter fall, through re-transporting leached Ca, however depends on tree species, and the presence of a subsoil of suitable quality, that is, clay enriched and with high Ca saturation (Vanlauwe et al. 2005).

Using lime is an option, so far locally available and transportable. But liming runs the risk of increased mineralization, that is, humus decomposition beyond what is needed, and there are cost factors.

## **Cattle, Dairy, Sheep, and Goat Systems**

Ruminants play an intermediate position between crops and manure. Current feeding ratios are often of low quality. Overgrazed grassland, lack of any forage crops in the crop rotation, alley crops, and hybrid grasses (*Pennisetum spp.*; *Brachiaria spp.*) are the explaining factors. Specifically, protein deficits explain also the low performance in dairy production. Intense use of straw and stubble after crop harvests – a main forage source – reduces the humus level of soils, specifically if organic manure is not recirculated to the fields, which is in manure farms the practice and is increasing soil erosion. Without a forage management including access to water, positive outcomes of breeding programs cannot be transferred into practice. To add cereals or grain legumes in the feed ratios compete directly with human food and cannot be recommended as a key strategy, except the use of leftovers.

Ruminant demand for forage legumes, hybrid grasses (Ghimire et al. 2015), forage trees/alley crop branches (Franzel et al. 2014), and silvopastoral systems fit with the CCAM strategies, due to the fact that they all contribute to an increase of biomass production, farm internal nitrogen supply, and milk productivity per land unit. As a result, the organic manure nutrient content and quantities increase, which can serve as a valuable fertilizer for crops and for supporting soil functions.

---

## **Agricultural Production Systems Contributions to CCAM**

This section first discusses diverse agricultural production methods and how they relate to each other in order to identify communalities and differences. As seen in the description of single CCAM relevant methods, they often refer to CA and OF. Table 3 informs about differences and similarities within an African context.

## **Sustainable Intensification – Some Terminological Clarifications**

Most prominent agricultural production methods in recent years can be summarized as “Sustainable intensification (SI),” which is defined as meeting the growing demand for agricultural production while conserving land and other resources, “from the same area of land while reducing the negative environmental impacts

**Table 3** Assessment of CCAM relevant methods in CA and OA

	Agricultural production methods	
	Conservation agriculture	Organic agriculture
<b>CCAM relevant methods</b>		
Crop rotation	++	+++
Crop rotation	++	+++
• Forage legumes	++ – +++	+++
• Relay cropping	+++	+++
• Intercropping	+++	+++
• Green manure	+++	+++
Farmyard manure	+++	+++
Compost	+++	+++
Mulching	+++	+++
Minimal tillage	+++	+ – ++
Hybrid grass	++	++
Alleys/hedges	+++	+++
Silvopast. Systems	++	+++
pH regulation	+++	+++
Biodiversity <sup>a</sup>	+	+++
<b>Other methods</b>		
Nitrogen fertilizer	a	e
P, K mineral fertilizer	a	a (accepted are low soluble fertilizers)
Herbicides	a	e
Pesticides	a	e

Source: Authors compilation

+ = low; ++ = medium; +++ = high; /=not applicable; – = indicating intermediate position; 0 = not explicitly mentioned; a = accepted; e = excluded

<sup>a</sup>via biotope diversity

and at the same time increasing contributions to natural capital and the flow of environmental services” (Khan et al. 2017). This term also accounts for the human condition, nutrition, and social equity. In their review, Smith et al. (2017) conclude, using a broad range of socio-, cultural, and socio-economic measures, that most current agricultural practices fall into this category. SI does not explicitly exclude any farming practice or requires an obligatory production framework, as, for example, the case for conservation agriculture with minimum tillage and mulching, or organic farming that excludes some farming and processing inputs. Mahon et al. (2017) conclude that SI is an oxymoron, underpinned by a productivist agenda, and that it is lacking a clear rationale. In their review, Xie et al. (2019) identify the reduction of yield gap as the main target of SI. But the intense use of mineral fertilizers is also not excluded (Holden 2018). Yet others, like Mdee et al. (2019), understand SI to be based on agroecological methods, or to classify integrated pest management as a core activity (Pretty and Bharucha 2015).

Definitions of CA do not explicitly exclude mineral fertilizers, herbicide and pesticide applications, but keep them at an option. Consequently, Vanlauwe et al.

(2014b) summarize three conceptual pathways for intensification paradigms: (i) integrating soil fertility management ending up in conservation agriculture, (ii) push and pull systems (Khan et al. 2008b), and (iii) evergreen agriculture (agroforestry-based systems) (Garrity 2017). All of these systems contribute to high soil health status and productivity through somewhat different pathways. In contrast to the overall definition of SI, which includes overlaps of sustainable and ecological intensification (Wezel et al. 2015), these pathways are classified as being only part of ecological intensification and thus only cover partially what is discussed under the term SI.

Another concept, Climate Smart Agriculture (CSA), is defined by the FAO as “agriculture that sustainably increases productivity, resilience (adaptation), reduces/removes greenhouse gases (mitigation), and enhances achievement of national food security and poverty reduction” (Nyasimi et al. 2014). CSA refers to food security and rural livelihood improvement through agricultural concepts that facilitate climate change adaptation and provide mitigation benefits (Scherr et al. 2012). Arable and plant cultivation methods applied refer to many of the field-based and farm-based sustainable agricultural land management practices identified as part of SI. As Zougmore et al. (2016) suggest in their analysis of CCAM relevant approaches, CSA is a farming method like CA.

“Sustainable land (use) management (SLM)” as the last approach, which should be mentioned in this brief analysis, is a compilation of methods that summarizes many of the activities already introduced above. Gurtner et al. (2011) define SLM as “the adoption of land use systems that, through appropriate management practices, enables land users to maximize the economic and social benefits from the land whilst maintaining or enhancing the ecological support functions of the land resources.” Arable and plant cultivation methods of SLM include soil fertility and crop management, soil erosion control measures, organic fertilization, minimum soil disturbance, and incorporation of residues, terraces, water harvesting and conservation, and agroforestry, grazing and forest management (Branca et al. 2013; Cordingley et al. 2015). But scholars highlight different specific methods. Dale (2010) defines SLM mainly as a technology approach to cope with erosion via mainly technical interventions and less one defined by crop-based systems.

## Conservation Agriculture

Conservation agriculture (CA) integrates three principles (FAO) ([www.fao.org/ag/ca](http://www.fao.org/ag/ca)): (i) avoiding or minimizing mechanical soil disturbance; (ii) enhancing and maintaining a permanent mulch cover with organic matter on the soil surface; and (iii) diversifying species (Kassam et al. 2017). Today CA is associated with three other agricultural production systems.

Push and pull system discussed as a core subsystem of CA, but also described as a climate smart technology that combines maize with undersown forage legumes and Napier grass, and with a minimum tillage approach (Midega et al. 2015), fulfills many of the ecological functions that contribute importantly to CCAM (Table 3) and



enables sustainable cereal crop and livestock production intensification through ecosystem or agroecological approaches based on natural biological processes (Khan et al. 2014). In the face of CC, new drought-tolerant trap (e.g., *Brachiaria* cv. *Mulato*) and intercrop (drought-tolerant species of desmodium, e.g., *D. intortum*) plants have been studied to further develop the push and pull system (Khan et al. 2017). Another approach is Evergreen Conservation Agriculture, a subtype of CA, which focuses specifically on the integration of trees into crop and livestock production systems (Garrity 2017). Close to this system are agroforestry systems that include inter-planting of a broad range of leguminous shrubs (Pratt et al. 2002). For erosion control in combination with other conservation measures, for example, dense hedges of vetiver grass on contours are recommended (Bunderson et al. 2015).

The positive impacts of CA on yields are well documented (Mkonda and He 2017), with yield increases compared to traditional methods, for example, from 1 t ha<sup>-1</sup> to 3.5 t ha<sup>-1</sup> per cropping season (Khan et al. 2006) as well as increased milk production (Khan et al. 2008a; Khan et al. 2008b; Midega et al. 2014). As a result, CA is shown to contribute significantly to higher economic returns for the farmer (higher returns to both land and labor than conventional farmers' practices), thereby allowing reduced, and sometimes none, use of nitrogen fertilizers, herbicides, and pesticides. CA contributions towards carbon sequestration further underline their high contribution to CCAM (Gonzalez-Sanchez et al. 2019; Sommer et al. 2014).

## Organic Farming

Organic farming (OF), as described by internationally accepted guidelines, is designed to be followed for farmers who are approved by certification processes and want to market their products as organic. OF also embodies a set of ethical principles that serve to orient all the subsystems of this agricultural production system. OF relies on (agro-) ecological processes, biodiversity at all levels (species, genotype, habitat, landscape...), and nutrient and carbon cycles, and high contributions to reduce agricultural GHG emissions (Scialabba and Müller-Lindenlauf 2010). All CCAM methods are recommended (see also FAO 2011), while other methods with often critical impact on the environment, but also for CC are limited (Table 3).

A key characteristic of organic farming is the focus on soil fertility, as a result of diversified crop rotations with forage legumes, catch crop and intercropping, and organic manure, which is the basis of a healthy and sustainable production (Meyer 2010). These diversified crop rotations largely replace the functions of excluded inputs like soluble mineral fertilizers, herbicides, and pesticides (Freyer 2019). Forage legume-based crop rotations, agroforestry, and nutrient and carbon recirculation are of high relevance. From a systems perspective, all of these methods must be implemented to enable a productive system. Tillage systems follow the idea to avoid the mix of fertile above ground soil layers with less fertile in lower layers. How far tillage intensity can be reduced depends on precrop – following crop relations, produced above and below ground biomass, organic manure type and amount, and the demand for weed control or to initiate mineralization processes,

therefore cannot be generalized (Koepeke 2003). At this point the difference between OA and CA becomes relevant which is the exclusion of many external inputs in the OA system. Functions of these excluded inputs must be partly taken over by the tillage system.

Other characteristics of OA are the inclusion of traditional knowledge, material, and methods (Müller and Davis 2009). Also, local seed collection and use is an intrinsic part of organic agriculture (Forster et al. 2012). Such seeds might be an advantage to adapt under certain climatic conditions and contribute to maintaining agro-biodiversity.

Africa hosts the majority of organic farms worldwide, with almost 2.1 million hectares of certified organic agricultural land (2017), and at least 815,000 producers (Willer and Lernoud 2019). But what is currently missing is an evaluation of the practices in these organic farming systems. Annual farm certification only partially informs the extent and quality of CCAM applications.

Moreover, research lacks a convincing organic systems approach. If trials include amounts of organic fertilizers that are going beyond the production capacity or what is currently known on that in practice, crop rotation principles are ignored, and alley cropping is not integrated (Adamtey et al. 2016; Musyoka et al. 2017). Such trials are of low relevance for identifying the real potential of OA to CCAM. This limited availability of research trials hinders a more in-depth assessment of the organic approach. Specifically, in comparison to CA, the gap is huge.

In African countries, OA is often equated with traditional practices – whatever they are – less mechanized, and minimum use of chemical fertilizers and pesticides. The low input systems neither fulfill the organic principles of health, ecology, fairness, and care, are not in line organic guidelines, nor would survive any organic farming certification process (Nalubwama et al. 2011).

---

## Discussion

This section summarizes and provides an orientation to the interdependence of CCAM relevant methods. It informs the challenges of farmers to adopt and refers to farmers' perspectives, agroecological, social, livelihoods, and the surrounding conditions for implementing CCAM, as well as how to interpret communalities and differences between CA and OA.

### The Logic of CCAM Practices

The interdependence of CCAM relevant methods is a key to understand their efficiency, success, or failure, not only for CC, but also their impact on productivity. Methods can be classified into two levels:

- First level: Methods that provide biomass and nitrogen: Legume based Agroforestry systems, silvopastoral systems, forage legume-based/green manure cover

crop, relay crop and intercrop-based crop rotation systems, and perennial productive high breed grasses.

- Second level: Methods that depend on the productivity and management of first level methods: mulching, manure and compost production, minimum tillage, pH regulation, biodiversity for pest and disease regulation.

Of course, isolating the yield effects of individual practices is complicated (Branca et al. 2013), but without optimal management of first level methods, second level methods cannot be activated or are weak in their performance. In other words, if methods in the first level are not well established, second level methods cannot be put in place. In organic farming, the application of CCAM relevant methods is obligatory to enable productivity with limited input from outside. Exclusion of one method would weaken the whole system. Of high relevance is the management quality of applied methods which allow that, even with very low amounts of residues, increases in the productivity with respect to conventional farming practices (Sommer et al. 2012). This fact is often overlooked. OA is very clear on this point – there are no half measures – if so, the system would fail both in CCAM and in productivity.

## Barriers for Adoption CCAM from a Production Perspective

In recent decades, extensive efforts to promote CA, CSA, or SLM have been undertaken. Despite extensive past efforts by governmental, nongovernmental, and research organizations to promote SLM to smallholder farmers in SSA, adoption remains low (Cordingley et al. 2015). What are the barriers to establish these methods from a production perspective?

- Crop specific: forage legume seeds, agroforestry seedlings and tree management, hybrid grass seeds, pasture seeds, weed control.
- Technically specific: soil tillage and seed technology, technology for cut and carry systems, stable construction, water management, storage, transportation and distribution of organic manure and compost.

Challenges to implement CCAM approaches are obviously not essentially different between CA and OA. The difference lies in the accessibility of nitrogen fertilizer, herbicides (Wall 2017), and pesticides that all can be applied as “emergency” methods in CA, while not in OA. These inputs provide CA farmers a set of methods that can be used when the crops are in a critical stage (lack of nitrogen, high weed pressure, expected outbreak of pest and diseases).

The differences between CA and OA can be identified largely in the so-called “other methods” (Table 3). Neither soluble mineral fertilizers nor herbicides and pesticides are allowed in either to bridge critical weather conditions, weed, or pest and disease development. Nitrogen fertilizer is the most relevant input with high impact on GHG emissions.

The application of these inputs is also controversially discussed in CA. While some argue that the three CA principles are sufficient to guide CA practices (Sommer et al. 2014; Wall 2017), Vanlauwe et al. (2014) identified a fourth principle, the application of mineral fertilizers. Many farmers believe that CA cannot be undertaken without specific inputs and tools, a message commonly conveyed to them by extension staff (e.g., hybrid seed, fertilizers, herbicides, knapsack sprayers, jab planters,...) (Bunderson et al. 2015). For farmers, the exclusion of “other methods” would limit the acceptance of CA and its scale on farms. Farmers also fear an increased abundance of termites and earthworms as harmful, whereas in fact they can have beneficial effects on the soil and crops (ibid). But there are also voices from the organic side that agriculture in Africa without herbicides and synthetic fertilizers is not possible and vote for their integration into the organic guidelines (Lotter 2015). The result would be simply CA. Other surveys report that farmers’ perceptions indicate that CA without external inputs, such as fertilizers, herbicides, pesticides, or compost, can improve yields relative to conventional agriculture. This argument is supported by the observations of scientists that a large proportion of soils in sub-Saharan Africa can be described as nonresponsive (Tittonell and Giller 2013), in which mineral fertilizer applications do not result in higher crop yields, while already the application of the three CA principles led to serious higher yields in comparison to the conventional input driven approach (Ngwira et al. 2013; Thierfelder and Wall 2010). Also, effective weed management is possible without the use of herbicides, since all three CA practices contribute to integrated weed control, also experienced in organic farming, if crop rotation and weed management are organized following latest knowledge. These observations are a clear reference about the OA system that also builds besides other methods on the three CA principles. These experiences are also showing that subsidizing of inputs is not a necessary precondition to CA use and uptake (Bunderson et al. 2015; Lalani et al. 2017).

According to FAO (2012), 80% of all farms in Africa have an agricultural area of <2 ha. These fragmented small land holdings preclude the effectiveness of large machinery in fieldwork, specifically for cut and carry systems, mulch-seeding systems/zero-tillage direct seeders, or the distribution of farm yard manure or mulch from outside the field, or from alleys (Sims et al. 2017; Sommer et al. 2014). In contrast, Lalani et al. (2017) observed that manual forms of CA can be attractive for farmers, particularly those with very small plots of land (0.5 ha or less), observing that mulching systems can reduce weed pressure.

Labor for biomass management is discussed as a barrier to the adoption of some CA methods, while others like seed varieties that are drought tolerant and early maturing are classified as the most suited technologies for smallholder farmers to respond react to CC (Senyolo et al. 2018). To define the CA approach only with drought resistant seed material, optimized irrigation and mineral fertilizers fail the overall idea, which could be also titled with “CA by default” or a conventionalized CA; of course it is less complex to apply a hand full of fertilizers and a herbicide instead of developing diversified crop rotation, mulching, and agroforestry systems.

A further barrier of CA/OA systems with the CCAM approaches is that they cannot be put in place in one season. Often the starting points for transforming the

system are poor soil fertility, land degradation, pests, and erratic rainfall that are challenging the adoption (Sietz and Van Dijk 2015). It is therefore not only about implementing new farming methods, but also to “repair” the damaged natural system. There is a conversion period of 2 to 3 years as it is also for OA, where farmers primarily have to invest in the transformation of the system. This requires a period of labor and financial investment, and patience by farmers until trade-offs of the new system become visible in an increase of productivity (Lalani et al. 2017).

In addition to these relevant hurdles, it is to keep in mind that weed and pest and disease control are a challenge for all farmers, irrespective of the CCAM methods, and not specific for CA/OA, like diversified crop rotations, in comparison to maize monocropping (Thierfelder et al. 2013; Thierfelder and Wall 2010); however, the high increase of pest and diseases provoked by monocropping and biodiversity poor landscapes underlines that farmers on the long run have no other choice than to modify their system, independent from CC.

## Markets, Policies, and Education for a Diversified Production

The implementation process of CCAM methods still lacks a clear conceptual understanding (Partey et al. 2018). The poor understanding of CA/OA, its CCAM methods, and suspected contradictions over what it means reflect the absence of an overall educational training program for teachers, extension officers, and students (Bunderson et al. 2015). Field trials should not lack of first level CCAM approaches (see the example of (Thierfelder et al. 2013, 2016); without training programs for farmers, chances for successful adoption of CCAM will continue slim (Erenstein et al. 2012).

Diversified production is also not possible without a policy and market enabling crop diversity and rewarding the contributions toward biodiversity and CCAM. Sustainable out-scaling of CCAM and to achieve large-scale landscape adoption depends on linkage to functional markets for inputs and outputs (Sommer et al. 2014). There is need for more attention via policy and extension on value chains, and more focused development resources from donors, governments, nongovernmental organizations (NGOs), and national and international research and development organizations to support participatory dissemination and upscaling of CCAM approaches (Friedrich et al. 2012). Investment policies should focus along value chains from technology at farm level, up to processing, and the availability of specifically forage legume seeds and tree seedlings.

Certification, that is, labeling of CCAM based agriculture, might be an option to support their implementation if linked with subsidies. In case of OA certification, schemes protecting the production status is currently only a half solution to increase the share of CCAM approaches in practice, due to the fact that only farmers with products for export are able to partly cover the relatively high certification costs. For local markets, certified products with a premium price are not adapted to the economic conditions of local population. Apart from specific investment costs, the successful implementation of CCAM methods would increase production and thus

farmers income, making additional price premiums less important. An ecosystem services-based payment scheme might be an option; however, the administrative costs can be currently higher than the money reaching the farmers pocket.

To make an impact, integrated participatory catchment strategies are expected to be most efficient in terms of adoption of CCAM methods, via technology, advisory and financial support, and the implementation of an impact monitoring (Scherr et al. 2012).

Sensitivity must be given of the vulnerable and marginalized (women and poorer households, for instance) to avoid the exclusion and a social gradient (Feder et al. 2010). Multiple communication tools are discussed as a precondition for successful implementation of CCAM (Leeuwis and Aarts 2011). To bring together broad experience for learning and encouraging innovation, communication platforms should be established including farmers' organizations, advisory services, and universities. Social acceptance by referents, and shared learning processes, plays a key role in this regard (Lalani et al. 2017).

National policies have to frame this process, for example, to strengthen the establishment of a seed and seedling sector specifically for forage legumes and legume trees, while regional land locally sensitive policy instruments serve for finetuning of product specific value chains (Zougmore et al. 2016).

---

## Conclusions

This chapter summarizes the status and potential of smallholder farmers' application of CCAM practices and some observations on the institutional environment, with reference mainly to the subtropical/tropical environments of East African smallholder farming.

Lessons learned are that many CCAM relevant arable and plant cultivation methods are available, but most of these are still not in place. It is obvious that all CCAM methods contribute to an increase of productivity, with minor exceptions, where systems need further development.

With respect to agricultural production systems where the integration of CCAM methods is far advanced, conservation agriculture (CA) builds on the use of farm inputs including nitrogen fertilizer, soluble mineral fertilizers, herbicides, and chemical pesticides, while organic agriculture (OA) excludes these inputs. To what extent these inputs are a precondition for successful CA management is a matter of controversy. CCAM methods are practically similar in both approaches – CA and OA – while the degree of their implementation and favored methods might be different.

The amount of biomass production and nitrogen by nitrogen fixing crops is a key driver of CCAM and an increase of farm productivity. Both can serve as general indicators to assess farms, that is, catchments in their progress to cope with CC and to boost productivity, while it is less the share of mineral fertilizer. Most relevant crop groups with highest impact are forages legumes, forage grain legumes, and leguminous alley crops, but also biomass rich hybrid grasses, that profit indirectly

from the forage legume nitrogen, for example, via slurry. These crop groups are the ones that increase soil fertility, reduce soil erosion and increase water holding capacity, biological pest and disease control, provide the feed biomass for animal husbandry systems, and guarantee an increase of cash crop yield and quality. Critical is the low supply of specifically forage legumes in seed markets.

There are still open questions, specifically concerning the GHG of mulching systems, pest and disease management and weed control, adapted technology for small scale farming and catchment strategies for a synergetic and efficient management. But those aspects are more part of a site and farm specific fine tuning than of fundamental lack of knowledge, which currently characterizes one of the main innovation barriers.

The dramatic negative trends of soil quality, biodiversity, and CC speak a clear language that the agricultural systems must bid farewell to one-sided systems. There is a need for a fundamental change, that is, resetting of the current farming practices, in other words, adaptation is no longer the appropriate term but the comprehensive transformation of the farming system as a whole. This is only possible if there is an enabling institutional and policy environment that supports agricultural research, advisory services, and education oriented to farmers' needs to adapt their farming system, making it more robust against drought and floods through the establishment of biomass and nitrogen producing cropping systems, and is reducing the farm specific negative impact on CC. This transformation process depends on assuring that best practices, adapted to local conditions, can demonstrate a reduction of labor, and a serious increase of farm income. It is recommended to apply a more systemic view in developing farming systems and related value chains, instead of focusing on single methods, that is, products. Transformation towards biodiverse crop rotations and biomass management also asks for the respective markets, consumer demands, and processing units, for example, for an increased milk production as a result of increased forage production, a dairy structure, and adaptations, that is, transformations of human diets. These final remarks clearly inform about the need for systemic transformation of food systems for successful CCAM management.

---

## References

- Achieng J, Ouma G, Odhiambo G, Muyekho F (2010) Effect of farmyard manure and inorganic fertilizers on maize production on Alfisols and Ultisols in Kakamega, western Kenya. *Agric Biol J N Am* 1(4):430–439
- Adamtey N, Musyoka MW, Zundel C, Cobo JG, Karanja E, Fiaboe KK, ... Berset E (2016) Productivity, profitability and partial nutrient balance in maize-based conventional and organic farming systems in Kenya. *Agric Ecosyst Environ* 235:61–79
- Awazi NP, Tchamba MN (2019) Enhancing agricultural sustainability and productivity under changing climate conditions through improved agroforestry practices in smallholder farming systems in Sub-Saharan Africa. *Afr J Agric Res* 14(7):379–388
- Branca G, Lipper L, McCarthy N, Jolejole MC (2013) Food security, climate change, and sustainable land management. A review. *Agron Sustain Dev* 33(4):635–650
- Broom D, Galindo F, Murgueitio E (2013) Sustainable, efficient livestock production with high biodiversity and good welfare for animals. *Proc R Soc B Biol Sci* 280(1771):20132025

- Bunch R (2017) How can we cover millions of hectares with conservation agriculture in Africa. Conservation agriculture for Africa: building resilient farming systems in a changing climate. CABI: Boston, 139
- Bunderson WT, Jere ZD, Thierfelder C, Gama M, Mwale BM, Ng'oma SW, . . . Mkandawire O (2015) Implementing the principles of conservation agriculture in Malawi: crop yields and factors affecting adoption. Conservation Agriculture for Africa: Building Resilient Farming Systems in a Changing Climate
- Cordingley JE, Snyder KA, Rosendahl J, Kizito F, Bossio D (2015) Thinking outside the plot: addressing low adoption of sustainable land management in sub-Saharan Africa. *Curr Opin Environ Sustain* 15:35–40
- Dale D (2010) Sustainable land management technologies and approaches in Ethiopia. SLMP. Natural Resources Management Sector, MOARD, Addis Ababa
- Dupar M (2019) Intergovernmental Panel on Climate Change (2019). Climate Change and Land: An IPCC Special Report on climate change, desertification, land degradation, sustainable land management, food security, and greenhouse gas fluxes in terrestrial ecosystems. Rome
- Elwell H, Stocking M (1988) Loss of soil nutrients by sheet erosion is a major hidden farming cost. *Zimb Sci News* 22(7):8
- Erenstein O, Sayre K, Wall P, Hellin J, Dixon J (2012) Conservation agriculture in maize-and wheat-based systems in the (sub) tropics: lessons from adaptation initiatives in South Asia, Mexico, and Southern Africa. *J Sustain Agric* 36(2):180–206
- FAO (2011) Save and grow - a policymaker's guide to the sustainable intensification of smallholder crop production. FAO, Rome
- FAO (2012) The State of Food and Agriculture. FAO, Rome
- Feder G, Anderson JR, Birner R, Deininger K (2010) Promises and realities of community-based agricultural extension. In *Community, Market and State in Development*. Springer, New York (pp. 187–208)
- Forster D, Adamtey N, Messmer MM, Pffiffer L, Baker B, Huber B, Niggli U (2012) Organic agriculture—driving innovations in crop research. In *Agricultural sustainability-progress and prospects in crop research*. Elsevier, pp 21–46
- Franzel S, Carsan S, Lukuyu B, Sinja J, Wambugu C (2014) Fodder trees for improving livestock productivity and smallholder livelihoods in Africa. *Curr Opin Environ Sustain* 6:98–103
- Freyer B (2019) The role of the crop rotation in organic farming. In: Köpke U (ed) *Improving organic crop cultivation*. Burleigh Dodds Science Publishing Limited, Cambridge, MA, pp 547–568
- Friedrich T, Derpsch R, Kassam A (2012) Overview of the global spread of conservation agriculture. *Field actions science reports*. *J Field Actions (Special Issue 6)*, p. 1–7
- Garrity DP (2017) How to make conservation agriculture evergreen. In Kassam AH, Mkomwa S, Friedrich T (eds) *Conservation agriculture for Africa. Building resilient farming systems in a changing climate*. CABI: Boston. pp 167–182
- Ghimire SR, Njarui DM, Mutimura M, Cardoso Arango JA, Johnson L, Gichangi E, . . . Rao IM (2015) Climate-smart *Brachiaria* for improving livestock production in East Africa: Emerging opportunities. Paper presented at the Sustainable use for grassland resources for forage production, Range Management Society of India, Jhansi, India
- Giller KE, Corbeels M, Nyamangara J, Triomphe B, Affholder F, Scopel E, Tittonell P (2011) A research agenda to explore the role of conservation agriculture in African smallholder farming systems. *Field Crop Res* 124(3):468–472
- Gómez-Carabali A, Idupulapati Madhusudana R, Ricaute J (2010) Differences in root distribution, nutrient acquisition and nutrient utilization by tropical forage species grown in degraded hillside soil conditions<sup>1</sup>. *Acta Agronómica* 59(2):197–210
- Gonzalez-Sanchez EJ, Veroz-Gonzalez O, Conway G, Moreno-Garcia M, Kassam A, Mkomwa S, . . . Carbonell-Bojollo R (2019) Meta-analysis on carbon sequestration through conservation agriculture in Africa. *Soil Tillage Res* 190:22–30
- Grant MJ, Booth A (2009) A typology of reviews: an analysis of 14 review types and associated methodologies. *Health Inform Libr J* 26(2):91–108



- Gurtner M, Liniger H, Studer R, Hauert C (2011) Sustainable land management in practice: Guidelines and best practices for Sub-Saharan Africa. FAO, Rome
- Hillocks R (1998) The potential benefits of weeds with reference to small holder agriculture in Africa. *Integr Pest Manag Rev* 3(3):155–167
- Hobbs PR, Govaerts B (2010) How conservation agriculture can contribute to buffering climate change. *Climate change and crop production*. CABI, Cambridge, p. 177–199
- Holden ST (2018) Fertilizer and sustainable intensification in Sub-Saharan Africa. *Glob Food Sec* 18:20–26
- IPCC (2018) Special Report Climate Change and Land. IPCC, Rome
- Kassam A, Basch G, Friedrich T, Gonzalez E, Trivino P, Mkomwa S (2017) Mobilizing greater crop and land potentials sustainably. *Hung Geograph Bull* 66(1):3–11
- Khan Z, Pickett JA, Wadhams LJ, Hassanali A, Midega CA (2006) Combined control of *Striga hermonthica* and stemborers by maize–*Desmodium* spp. intercrops. *Crop Prot* 25(9):989–995
- Khan Z, Amudavi DM, Midega CA, Wanyama JM, Pickett JA (2008a) Farmers' perceptions of a 'push-pull' technology for control of cereal stemborers and *Striga* weed in western Kenya. *Crop Prot* 27(6):976–987
- Khan Z, Midega CA, Amudavi DM, Hassanali A, Pickett JA (2008b) On-farm evaluation of the 'push-pull' technology for the control of stemborers and *striga* weed on maize in western Kenya. *Field Crop Res* 106(3):224–233
- Khan Z, Midega CA, Pittchar JO, Murage AW, Birkett MA, Bruce TJ, Pickett JA (2014) Achieving food security for one million sub-Saharan African poor through push-pull innovation by 2020. *Philos Trans R Soc B: Biol Sci* 369(1639):20120284
- Khan Z, Midega CA, Hooper A, Pickett J (2016) Push-pull: chemical ecology-based integrated pest management technology. *J Chem Ecol* 42(7):689–697
- Khan Z, Midega CA, Pittchar J, Murage A, Pickett J (2017) Climate-smart push-pull: a conservation agriculture technology for food security and environmental sustainability in Africa. In: *Conservation agriculture for Africa: building resilient farming systems in a changing climate*. BABI, Wallingford, pp 151–166
- Koepke U (2003) Conservation agriculture with and without use of agrochemicals. Paper presented at the proceedings of the 2nd world congress on conservation agriculture, Iguassu Falls, Paraná, Brazil
- Kumar S, Meena RS, Lal R, Yadav GS, Mitran T, Meena BL, ... Ayman E-S (2018) Role of legumes in soil carbon sequestration. In *Legumes for Soil Health and Sustainable Management*. Springer, New York (pp. 109–138)
- Lalani B, Dorward P, Kassam AH, Dambiro J (2017) Innovation systems and farmer perceptions regarding conservation agriculture in Cabo Delgado, Mozambique. AH Kassam, S. Mkomwa, & T. Friedrich, *Conservation Agriculture for Africa: Building resilient farming systems in a changing climate*, 100–126. CABI, Boston
- Lasco RD, Delfino RJP, Catacutan DC, Simelton ES, Wilson DM (2014) Climate risk adaptation by smallholder farmers: the roles of trees and agroforestry. *Curr Opin Environ Sustain* 6:83–88
- Leeuwis C, Aarts N (2011) Rethinking communication in innovation processes: creating space for change in complex systems. *J Agric Educ Extension* 17(1):21–36
- Lotter D (2015) Facing food insecurity in Africa: why, after 30 years of work in organic agriculture, I am promoting the use of synthetic fertilizers and herbicides in small-scale staple crop production. *Agric Hum Values* 32(1):111–118
- Mahon N, Crute I, Simmons E, Islam MM (2017) Sustainable intensification—"oxymoron" or "third-way"? A systematic review. *Ecol Indic* 74:73–97
- Majumder K (2015) *A young researcher's guide to a systematic review*. Editage, Japan
- Mason-D'Croz D, Sulser TB, Wiebe K, Rosegrant MW, Lowder SK, Nin-Pratt A, ... Cenacchi N (2019) Agricultural investments and hunger in Africa modeling potential contributions to SDG2—Zero Hunger. *World Dev* 116:38–53
- Mbow C, Smith P, Skole D, Duguma L, Bustamante M (2014) Achieving mitigation and adaptation to climate change through sustainable agroforestry practices in Africa. *Curr Opin Environ Sustain* 6:8–14

- Mchunu CN, Lorentz S, Jewitt G, Manson A, Chaplot V (2011) No-till impact on soil and soil organic carbon erosion under crop residue scarcity in Africa. *Soil Sci Soc Am J* 75(4):1503–1512
- Mdee A, Wostry A, Coulson A, Maro J (2019) A pathway to inclusive sustainable intensification in agriculture? Assessing evidence on the application of agroecology in Tanzania. *Agroecol Sustain Food Syst* 43(2):201–227
- Meyer R (2010) Low-input intensification in agriculture chances for small-scale farmers in developing countries. *Gaia-Ecol Perspect Sci Soc* 19(4):263–268
- Midega CA, Salifu D, Bruce TJ, Pittchar J, Pickett JA, Khan ZR (2014) Cumulative effects and economic benefits of intercropping maize with food legumes on *Striga hermonthica* infestation. *Field Crop Res* 155:144–152
- Midega CA, Bruce TJ, Pickett JA, Pittchar JO, Murage A, Khan ZR (2015) Climate-adapted companion cropping increases agricultural productivity in East Africa. *Field Crop Res* 180:118–125
- Mkonda MY, He X (2017) Conservation agriculture in Tanzania. In: *Sustainable agriculture reviews*. Springer, Berlin, pp 309–324
- Monegat C (1991) Plantas de cobertura del suelo: características y manejo en pequeñas propiedades. Universidad Nacional Agraria, (UNA), Nicaragua Centro Nacional de Investigación y Documentación Agropecuaria, (CENIDA)
- Müller A, Davis JS (2009) Reducing global warming: the potential of organic agriculture. FiBL, Frick, Switzerland
- Murthy IK, Gupta M, Tomar S, Munsri M, Tiwari R, Hegde G, Ravindranath N (2013) Carbon sequestration potential of agroforestry systems in India. *J Earth Sci Clim Chang* 4(1):1–7
- Murthy IK, Dutta S, Vinisha V (2016) Impact of agroforestry systems on ecological and socio-economic systems: a review. *Glob J Sci Front Res: H Environ Earth Sci* 16(5):15–27
- Musyoka MW, Adamtey N, Muriuki AW, Cadisch G (2017) Effect of organic and conventional farming systems on nitrogen use efficiency of potato, maize and vegetables in the Central highlands of Kenya. *Eur J Agron* 86:24–36
- Nalubwama SM, Mugisha A, Vaarst M (2011) Organic livestock production in Uganda: potentials, challenges and prospects. *Trop Anim Health Prod* 43(4):749–757
- Nandwa S, Obanyi S, Mafongoya P (2011) Agro-ecological distribution of legumes in farming systems and identification of biophysical niches for legumes growth. In: *Fighting poverty in Sub-Saharan Africa: the multiple roles of legumes in integrated soil fertility management*. Springer, Dordrecht, pp 1–26
- Ndambi OA, Pelster DE, Owino JO, De Buissonje F, Vellinga T (2019) Manure management practices and policies in sub-Saharan Africa: implications on manure quality as a fertilizer. *Front Sustain Food Syst* 3:29
- Ngwira AR, Thierfelder C, Lambert DM (2013) Conservation agriculture systems for Malawian smallholder farmers: long-term effects on crop productivity, profitability and soil quality. *Renew Agric Food Syst* 28(4):350–363
- Nyasimi M, Amwata D, Hove L, Kinyangi J, Wamukoya G (2014) Evidence of impact: climate-smart agriculture in Africa
- Ochieng SA, Waiswa DC (2019) Pastoral education: the missing link in Uganda education system. *Educ Res Rev* 14(7):240–253
- Partey ST, Zougmore RB, Ouédraogo M, Campbell BM (2018) Developing climate-smart agriculture to face climate variability in West Africa: challenges and lessons learnt. *J Clean Prod* 187:285–295
- Porter JR, Challinor AJ, Henriksen CB, Howden SM, Martre P, Smith P (2019) Invited review: intergovernmental panel on climate change, agriculture, and food—a case of shifting cultivation and history. *Glob Chang Biol* 25(8):2518–2529
- Powlson DS, Stirling CM, Jat ML, Gerard BG, Palm CA, Sanchez PA, Cassman KG (2014) Limited potential of no-till agriculture for climate change mitigation. *Nat Clim Chang* 4(8):678–683
- Pratt J, Henry E, Mbeza H, Mlaka E, Satali L (2002) Malawi agroforestry extension project marketing & enterprise program, main report. *Malawi Agroforestry* 47:139

- Pretty J, Bharucha ZP (2015) Integrated pest management for sustainable intensification of agriculture in Asia and Africa. *Insects* 6(1):152–182
- Reicosky DC (2015) Conservation tillage is not conservation agriculture. *J Soil Water Conserv* 70 (5):103A–108A
- Rusinamhodzi L, Corbeels M, Nyamangara J, Giller KE (2012) Maize–grain legume intercropping is an attractive option for ecological intensification that reduces climatic risk for smallholder farmers in Central Mozambique. *Field Crop Res* 136:12–22
- Sarvade S, Upadhyay V, Agrawal S (2019) Quality fodder production through silvo-pastoral system: a review. In: Dev I, Ram A, Kumar N, Singh R, Kumar D, Uthappa AR, Handa AK, Chaturvedi OP (eds) *Agroforestry for climate resilience and rural livelihood*. Scientific Publishers, Jodhpur, pp 345–359
- Scherr SJ, Shames S, Friedman R (2012) From climate-smart agriculture to climate-smart landscapes. *Agric Food Security* 1(1):12
- Schroth G, Balle P, Peltier R (1995) Alley cropping groundnut with *Gliricidia sepium* in Cote d'Ivoire: effects on yields, microclimate and crop diseases. *Agrofor Syst* 29(2):147–163
- Schultze-Kraft R, Rao IM, Peters M, Clements RJ, Bai C, Liu G (2018) Tropical forage legumes for environmental benefits: an overview. *Trop Grasslands-Forrajes Tropicales* 6(1):1–14
- Scialabba NE-H, Müller-Lindenlauf M (2010) Organic agriculture and climate change. *Renew Agric Food Syst* 25(2):158–169
- Scopel E, Triomphe B, Ribeiro MdS, Ségué L, Denardin JE, Kochann R (2004) Direct seeding mulch-based cropping systems (DMC) in Latin America. Paper presented at the new directions for a diverse planet: proceedings for the 4th international crop science congress, Brisbane
- Senyolo MP, Long TB, Blok V, Omta O (2018) How the characteristics of innovations impact their adoption: an exploration of climate-smart agricultural innovations in South Africa. *J Clean Prod* 172:3825–3840
- Sheaffer CC, Seguin P (2003) Forage legumes for sustainable cropping systems. *J Crop Prod* 8 (1–2):187–216
- Sietz D, Van Dijk H (2015) Land-based adaptation to global change: what drives soil and water conservation in western Africa? *Glob Environ Chang* 33:131–141
- Sims B, Kienzle J, Mkomwa S, Friedrich T, Kassam A (2017) Mechanization of smallholder conservation agriculture in Africa; contributing resilience to precarious systems. *Conservation Agriculture for Africa. Building Resilient Farming Systems in a Changing Climate*; Kassam, AH, Mkomwa, S., Friedrich, T., Eds, 183–213. CABI, Boston
- Smith A, Snapp S, Chikowo R, Thorne P, Bekunda M, Glover J (2017) Measuring sustainable intensification in smallholder agroecosystems: a review. *Glob Food Sec* 12:127–138
- Sommer R, Piggitt C, Haddad A, Hajdibo A, Hayek P, Khalil Y (2012) Simulating the effects of zero tillage and crop residue retention on water relations and yield of wheat under rainfed semiarid Mediterranean conditions. *Field Crop Res* 132:40–52
- Sommer R, Thierfelder C, Tittonell P, Hove L, Mureithi J, Mkomwa S (2014) Fertilizer use should not be a fourth principle to define conservation agriculture: response to the opinion paper of Vanlauwe et al. (2014) 'A fourth principle is required to define conservation agriculture in sub-Saharan Africa: the appropriate use of fertilizer to enhance crop productivity'. *Field Crops Res* 169:145–148
- Teenstra E, de Buissonjé F, Ndambi A, Pelster D (2015) *Manure Management in the (Sub-) Tropics: training manual for extension workers*. Wageningen UR (University & Research centre) Livestock Research, Livestock Research Report 919
- Tesfa A, Mekuria S (2014) The effect of land degradation on farm size dynamics and crop-livestock farming system in Ethiopia: A Review. *Open Journal of Soil Science*, 2014, p. 1–5
- Thierfelder C, Wall P (2010) Rotation in conservation agriculture systems of Zambia: effects on soil quality and water relations. *Exp Agric* 46(3):309–325
- Thierfelder C, Cheesman S, Rusinamhodzi L (2013) Benefits and challenges of crop rotations in maize-based conservation agriculture (CA) cropping systems of southern Africa. *Int J Agric Sustain* 11(2):108–124

- Thierfelder C, Bunderson WT, Jere ZD, Mutenje M, Ngwira A (2016) Development of conservation agriculture (CA) systems in Malawi: lessons learned from 2005 to 2014. *Exp Agric* 52(4):579–604
- Thomas RJ, Asakawa N (1993) Decomposition of leaf litter from tropical forage grasses and legumes. *Soil Biol Biochem* 25(10):1351–1361
- Tittonell P, Giller KE (2013) When yield gaps are poverty traps: the paradigm of ecological intensification in African smallholder agriculture. *Field Crop Res* 143:76–90
- Trail S, Bell LW, Dalgliesh NP, Wilson A, Ramony L-M, Guppy C (2018) Tropical forage legumes provide large nitrogen benefits to maize except when fodder is removed. *Crop Pasture Sci* 69(2):183–193
- Tully K, Sullivan C, Weil R, Sanchez P (2015) The state of soil degradation in Sub-Saharan Africa: baselines, trajectories, and solutions. *Sustainability* 7(6):6523–6552
- Vanlauwe B, Aihou K, Tossah B, Diels J, Sanginga N, Merckx R (2005) Senna siamea trees recycle Ca from a Ca-rich subsoil and increase the topsoil pH in agroforestry systems in the West African derived savanna zone. *Plant Soil* 269(1–2):285–296
- Vanlauwe B, Coyne D, Gockowski J, Hauser S, Huising J, Masso C, ... Van Asten P (2014a) Sustainable intensification and the African smallholder farmer. *Curr Opin Environ Sustain* 8:15–22
- Vanlauwe B, Wendt J, Giller KE, Corbeels M, Gerard B, Nolte C (2014b) A fourth principle is required to define conservation agriculture in sub-Saharan Africa: the appropriate use of fertilizer to enhance crop productivity. *Field Crop Res* 155:10–13
- Wall P (2017) Conservation Agriculture: Growing More with Less—the Future of Sustainable Intensification. Conservation agriculture for Africa, CABI, Boston. p. 30–40
- Wezel A, Soboksa G, McClelland S, Delespesse F, Boissau A (2015) The blurred boundaries of ecological, sustainable, and agroecological intensification: a review. *Agron Sustain Dev* 35(4):1283–1295
- Wilkins RJ (2008) Eco-efficient approaches to land management: a case for increased integration of crop and animal production systems. *Philos Trans R Soc B: Biol Sci* 363(1491):517–525
- Willer H, Lernoud J (2019) The world of organic agriculture. Statistics and emerging trends 2019: Research Institute of Organic Agriculture FiBL and IFOAM Organics International
- Wilson G, Kang B, Mulongoy K (1986) Alley cropping: trees as sources of green-manure and mulch in the tropics. *Biol Agric Horticulture* 3(2–3):251–267
- Wynants M, Kelly C, Mtei K, Munishi L, Patrick A, Rabinovich A, ... Boeckx P (2019) Drivers of increased soil erosion in East Africa's agropastoral systems: changing interactions between the social, economic and natural domains. *Regional Environmental Change*, 19, p. 1909–1921
- Xie H, Huang Y, Chen Q, Zhang Y, Wu Q (2019) Prospects for agricultural sustainable intensification: a review of research. *Land* 8(11):157
- Zougmore R, Partey S, Ouédraogo M, Omitoyin B, Thomas T, Ayantunde A, ... Jalloh A (2016) Toward climate-smart agriculture in West Africa: a review of climate change impacts, adaptation strategies and policy developments for the livestock, fishery and crop production sectors. *Agric Food Security* 5(1):26
- Zougmore RB, Partey ST, Ouédraogo M, Torquebiau E, Campbell BM (2018) Facing climate variability in sub-Saharan Africa: analysis of climate-smart agriculture opportunities to manage climate-related risks. *Cahiers Agricultures (TSI)* 27(3):1–9

**Open Access** This chapter is licensed under the terms of the Creative Commons Attribution 4.0 International License (<http://creativecommons.org/licenses/by/4.0/>), which permits use, sharing, adaptation, distribution and reproduction in any medium or format, as long as you give appropriate credit to the original author(s) and the source, provide a link to the Creative Commons license and indicate if changes were made.

The images or other third party material in this chapter are included in the chapter's Creative Commons license, unless indicated otherwise in a credit line to the material. If material is not included in the chapter's Creative Commons license and your intended use is not permitted by statutory regulation or exceeds the permitted use, you will need to obtain permission directly from the copyright holder.





# Sustainable Food Production Systems for Climate Change Mitigation: Indigenous Rhizobacteria for Potato Bio-fertilization in Tanzania

# 71

Becky Nancy Aloo, Ernest Rashid Mbega, and Billy Amendi Makumba

## Contents

Introduction .....	1470
Materials and Methods .....	1471
Rhizobacterial Cultures .....	1471
Cultural, Microscopic, and Biochemical Characterization of the Rhizobacterial Cultures .....	1472
<i>In vitro</i> Experiments .....	1472
The Potted Experiment .....	1473
Statistical Analysis .....	1475
Results .....	1475
The Cultural, Microscopic, Biochemical, and Carbohydrate Utilization Properties of the Potato Rhizobacterial Isolates .....	1475
<i>In vitro</i> Plant Growth Promoting Abilities of the Potato Rhizobacterial Isolates .....	1479
Effects of the Rhizobacterial Treatments on Potato Growth Parameters and Rhizobacterial Soils in the Screen House Experiment .....	1481
Discussions .....	1488
Cultural, Microscopic, Biochemical, and Carbohydrate Utilization Properties of the Isolates .....	1488

---

B. N. Aloo (✉)

Department of Sustainable Agriculture and Biodiversity Conservation, Nelson Mandela African Institution of Science and Technology, Arusha, Tanzania

Department of Biological Sciences, University of Eldoret, Eldoret, Kenya  
e-mail: [aloob@nm-aist.ac.tz](mailto:aloob@nm-aist.ac.tz)

E. R. Mbega

Department of Sustainable Agriculture and Biodiversity Conservation, Nelson Mandela African Institution of Science and Technology, Arusha, Tanzania  
e-mail: [ernest.mbega@nm-aist.ac.tz](mailto:ernest.mbega@nm-aist.ac.tz)

B. A. Makumba

Department of Biological Sciences, Moi University, Eldoret, Kenya

© The Author(s) 2021

W. Leal Filho et al. (eds.), *African Handbook of Climate Change Adaptation*,  
[https://doi.org/10.1007/978-3-030-45106-6\\_276](https://doi.org/10.1007/978-3-030-45106-6_276)

1469

<i>In vitro</i> Plant Growth-Promoting Activities of the Potato Rhizobacterial Isolates .....	1489
Effects of the Rhizobacterial Treatments on Growth and Yield of Potted Potatoes .....	1490
Conclusions .....	1492
References .....	1492

## Abstract

The global rise in human population has led to the intensification of agricultural activities to meet the ever-rising food demand. The potato (*Solanum tuberosum* L.) is a crop with the potential to tackle food security issues in developing countries due to its short growth cycle and high nutrient value. However, its cultivation is heavily dependent on artificial fertilizers for yield maximization which culminates in global warming and other environmental problems. There is need, therefore, for its alternative fertilization technologies to mitigate climate change. This study evaluated the potential of indigenous rhizobacteria for potato cropping in Tanzania. Ten potato rhizobacterial isolates belonging to *Enterobacter*, *Klebsiella*, *Citrobacter*, *Serratia*, and *Enterobacter* genera were obtained from a previous collection from different agro-ecological areas in Tanzania. The isolates were characterized culturally, microscopically, biochemically, and by their carbohydrate utilization patterns. Their *in vitro* plant growth-promoting (PGP) traits such as nitrogen fixation, solubilization of phosphates, potassium, and zinc, and production of siderophores, indole acetic acid, and gibberellic acids were then evaluated. Lastly, sterilized potato seed tubers were bacterized with the inoculants and grown in pots of sterile soil in a screen-house using untreated plants as a control experiment. The potato rhizobacterial isolates had varying characteristics and showed varying *in vitro* PGP activities. The screen-house experiment also showed that the rhizobacterial treatments significantly ( $p < 0.05$ ) enhanced different parameters associated with potato growth by up to 91% and established the potential of most of the isolates as alternative biofertilizers in potato cropping systems in Tanzania.

## Keywords

Potato · Biofertilizer · Plant growth promoting rhizobacteria (PGPR) · Climate change · Sustainable agriculture

## Introduction

Potato (*Solanum tuberosum* L.) is an important crop for food and economic security in developing countries (FAO 2008). However, its cultivation is heavily dependent on the application of synthetic fertilizers (George and Ed 2011). The general recommendations of synthetic fertilizers for this crop are 120, 123, and 149–199 kg ha<sup>-1</sup> of nitrogen (N), phosphorus (P), and potassium (K), respectively,

for an average fresh tuber yield of 30 t ha<sup>-1</sup> (Manzira 2011). Nevertheless, these generous fertilizer applications do not always produce the desired results because the crop's rooting system is too shallow for the efficient recovery of fertilizers (Hopkins et al. 2014).

Attempts to establish suitable alternative fertilization mechanisms for crops to minimize environmental impacts and mitigate climate change are quickly gathering momentum worldwide (Kumar et al. 2018). In this context, plant rhizospheres have been the center of attention worldwide for decades. Plant roots secrete nutrient-rich exudates that attract plant growth-promoting rhizobacteria (PGPR) that contribute to plant growth promotion (PGP) directly or indirectly, for instance, through the production of phytohormones and siderophores, solubilization of phosphates, and biological nitrogen fixation (BNF) (Kumar et al. 2018).

Biofertilizers are PGPR-cultures which are developed for use as inoculants to improve soil fertility and plant productivity (Aloo et al. 2019). The PGPR of different crops like legumes have extensively been studied as biofertilizers, but the potato rhizobacterial communities are not yet fully understood, yet they could extremely be important as alternative biofertilizers for this crop. Understanding their interactions with the potato to unravel their PGP potentials for sustainable potato cropping is equally important. It is now known that indigenous PGPRs of specific crops can make better biofertilizers because they are completely adapted and established in specific environments and can be more competitive than introduced inoculants (Sood et al. 2018). Cognizant of this, the present study was designed to explore the PGP functions of indigenous rhizobacterial strains selected from a previous study that had isolated, and identified rhizobacteria from potato rhizospheres and tubers from different agro-ecological regions in Tanzania. The selected rhizobacteria were studied culturally, microscopically, biochemically and based on their carbohydrate (CHO)-utilization patterns. Their *in vitro* PGP functions and effects on various growth parameters of potato in pot experiments were investigated under screen-house conditions, using un-inoculated potato plants as controls. Understanding these bacteria and their functions can enable the identification of suitable inoculants for the development of sustainable potato cropping systems in Tanzania and provide deeper insights into the overall mitigation of climate change in Africa.

---

## Materials and Methods

### Rhizobacterial Cultures

Ten rhizobacterial cultures that had previously isolated from potato rhizosphere soils growing in various regions in Tanzania and identified using their 16S rRNA gene sequences (Aloo et al. 2020) were selected for the present study. The strains, sources, and species of these rhizobacterial cultures are displayed in Table 1.



**Table 1** Strains, sources, and species of the potato rhizobacterial isolates used in the study

SN	Strain code	Source	Strain identity
1	<i>LUTS1</i>	Luteba	<i>Klebsiella grimontii</i> <i>LUTS1</i>
2	<i>LUTS2</i>	Luteba	<i>Enterobacter tabaci</i> <i>LUTS2</i>
3	<i>MWAKS1</i>	Mwakaleli	<i>Klebsiella oxytoca</i> <i>MWAKS1</i>
4	<i>MWAKS5</i>	Mwakaleli	<i>Enterobacter asburiae</i> <i>MWAKS5</i>
5	<i>MATS3</i>	Matadi	<i>Enterobacter tabaci</i> <i>MATS3</i>
6	<i>MPUS2</i>	Mpunguti	<i>Enterobacter tabaci</i> <i>MPUS2</i>
7	<i>KIBS5</i>	Kibuko	<i>Serratia liquefaciens</i> <i>KIBS5</i>
8	<i>MWANS4</i>	Mwangaza	<i>Citrobacter freundii</i> <i>MWANS4</i>
9	<i>BUMS1</i>	Bumu	<i>Enterobacter ludwigii</i> <i>BUMS1</i>
10	<i>NGAS9</i>	Ngarenairobi	<i>Serratia marcescens</i> <i>NGAS9</i>

## Cultural, Microscopic, and Biochemical Characterization of the Rhizobacterial Cultures

The morphological characterization of the rhizobacterial colonies was performed based on their sizes, shapes, colors, margins, opacity, elevation, and texture as described by Somasegaran and Hoben (1994). The determination of Gram staining properties was performed using the 3% potassium hydroxide (KOH) string test (Pradhan 2016). Rhizobacterial smears were prepared and stained with safranin and observed under oil immersion ( $\times 100$ ) on a fluorescence microscope (Optika B-350) to determine the cell shapes. Evidence of flagella motility was checked in a motility test medium (MTM).

The qualitative assessment for the production of organic acids was determined using the methyl red (MR) (Sambrook and Russell 2001). The catalase test was used to identify isolates that produced catalases and the citrate test was used to detect the ability of the rhizobacterial isolates to utilize citrate as the sole source of carbon and energy on Simmons citrate agar (Simmons 1926). The ability of the isolates to produce hydrogen sulfide ( $H_2S$ ) was checked on sulfur indole motility (SIM) agar tubes, and the oxidative-fermentative (O-F) test medium was used to evaluate the oxidative and fermentative abilities of the isolates. The production of indole by the isolates was also performed on SIM cultures using Kovac's reagent. Lastly, the CHO utilization patterns of the isolates were glucose, sucrose, mannitol, maltose, dextrose, lactose, fructose, dulcitol, sorbitol, trehalose, cellobiose, and ribose as described by Hugh and Leifson (1953).

## *In vitro* Experiments

The rhizobacterial cultures were screened for various *in vitro* PGP activities. Pikovskaya's medium containing tricalcium phosphate (TCP) (Wahyudi et al. 2011) and Aleksandrov's medium containing potassium alumino-silicate (Sindhu et al. 1999) were used to evaluate for P and K solubilization by the rhizobacterial strains, respectively. Zinc solubilization assays were performed using ZnO as the

insoluble Zn source (Fasim et al. 2002). For the quantitative estimation of P, K, and Zn solubilization, the optical densities (OD) of culture supernatants from Pikoskaya's, Alexandrov's, and ZnO broths were determined spectrophotometrically at  $A_{690}$ ,  $A_{799}$ , and  $A_{399}$ , respectively, using a multimode reader (Synergy HTX – Biotek). The quantities of solubilized P, K, and Zn in  $\text{mg L}^{-1}$  were subsequently calculated from standard curves of  $\text{KH}_2\text{PO}_4$ , KCl, and  $\text{ZnSO}_4$ , respectively. The halozones around the bacterial colonies on the plates of respective insoluble compounds were measured and used to compute the solubilization index (SI) for each compound using Eq. 1 (Edi-Premona et al. 1996).

$$\text{Solubilization index (SI)} = \frac{\text{Colony Diameter (cm)} + \text{Halozone Diameter (cm)}}{\text{Colony Diameter (cm)}} \quad (1)$$

The production of IAA and GA by the isolates was evaluated as previously described by Vincent (1970) and Holbrook et al. (1961), respectively. The nitrogenase activities of the isolates were checked on solid and liquid N-free media (NFM). The formation of brown or yellow colors in the NFM broth cultures indicated  $\text{NH}_3$  production, and its OD was measured spectrophotometrically at 435 nm. The concentration of  $\text{NH}_3$  was then estimated by comparing the absorbance of samples with a standard curve of ammonium sulfate in the range of 0.0–10  $\text{mg L}^{-1}$  (Goswami et al. 2014). The siderophore production abilities of the isolates were assessed using chrome azurol S (CAS) liquid assays and agar plates as described by Schwyn and Neilands (1987). In the liquid CAS assays, the percent siderophore units (% SU) per isolate were calculated from the absorbance measurements of samples and reference solutions using Eq. 2 (Payne 1993).

$$\% \text{Siderophore units (\%SU)} = \frac{\text{Reference absorbance} - \text{Sample absorbance}}{\text{Reference absorbance}} \times 100\% \quad (2)$$

For the solid CAS assays, each experiment was performed in triplicates and the diameters of the orange or yellow halozones were used to calculate the siderophores production index (SI) using Eq. 3 (Batista 2012).

$$\text{Siderophore production index (SI)} = \frac{\text{Orange halozone (cm)}}{\text{Colony diameter (cm)}} \quad (3)$$

## The Potted Experiment

The rhizobacterial cultures were grown in 50 mL universal bottles filled with 25 mL Tryptic soy broth in a rotary shaker (200 rpm) for 16 h at 28 °C. The absorbance of the bacterial suspensions was evaluated spectrophotometrically at 600 nm using a multimode reader (Synergy HTX – Biotek), and each culture was diluted in sterile distilled water to a final concentration of  $1 \times 10^6$  CFUs  $\text{mL}^{-1}$ . The cells were

harvested by centrifugation at 4000 rpm for 20 min at 4 °C and resuspended in 100 mL of 7% Carboxy Methyl Cellulose (CMC) solution to help bind the cells to the tubers. Potato seed tubers sourced from a nearby local market were surface-sterilized (using 3% sodium hypochlorite for 3 min and rinsing four times in sterile distilled water). The tubers suspended in the prepared bacterial suspensions for 30 min and sown in plastic pots (20 cm wide) containing 250 g of 24-h oven-sterilized soil with pH: 7.33, electrical conductivity (EC): 207.33  $\mu\text{S cm}^{-1}$ , soluble salts: 0.07%, organic carbon (OC): 0.89%, organic matter (OM): 1.53%, N: 0.08%, zinc (Zn): 35.62  $\text{mg kg}^{-1}$ , P: 231.64  $\text{mg kg}^{-1}$ , K: 7.59  $\text{mg kg}^{-1}$ , iron (Fe): 1.31  $\text{mg kg}^{-1}$ , sand: 68.67%, clay + silt: 29.44% and gravel: 1.88%. The experiment was set up in a completely randomized block design with three replicate potato pots per treatment, giving a total of 93 pots for 90 bacterized tubers (10 isolates in three triplicates) and three nonbacterized tubers. The screen house conditions were naturally maintained at 20–22 °C with a day length of 12 h and watered every 48 h using sterile distilled water (150 mL  $\text{pot}^{-1}$ ).

The number of days to emergence (DTE) and flowering (DTF) per treatment was recorded and 90 days after planting (DAP), the crops were harvested and data obtained on the number of tubers, length and weight of shoots, and the average weight and size of tubers per plant. To obtain the average size of tubers per plant, the diameter of each tuber from each potato plant was measured using a measuring tape, and the diameter of tubers per plant obtained by dividing the total diameter of tubers per plant by the number of tubers from that plant. The average radius of tubers per plant was obtained by dividing the average diameter by two and used to determine the potato tuber size per plant (Eq. 4).

$$\text{Average tuber size} = \frac{4}{3} \pi \times (\text{Average radius})^3 \quad (4)$$

The potato rhizospheric soils were evaluated for various physicochemical properties. The pH and EC of the soils were analyzed by the saturated paste method as proposed by Jackson (1973) and Chi and Wang (2010), respectively. The (%) OC in the soils was determined by the potassium dichromate ( $\text{K}_2\text{Cr}_2\text{O}_7$ ) wet digestion method and the (%) OM of the samples was derived from the (%) OC using Eq. 5 (Walkley and Black 1934).

$$(\%) \text{ Organic Matter} = (\%) \text{ Organic Carbon} \times 1.724 \quad (5)$$

The N content in the rhizospheric soils was determined following the micro-Kjeldahl method (Bremmer and Mulvaney 2015). The Mehlich III method was used to extract the soil P and Zn (Tran and Simard 1993), while the extraction of K was performed using the ammonium acetate method (Jackson 1973). The 1, 10-phenanthroline complex method described by Chaurasia and Gupta (2014) was used for the extraction of Fe in the samples. The quantitative estimation of P, K, Zn, and Fe in the soil extracts was performed by determining the OD spectrophotometrically at  $A_{690}$ ,  $A_{799}$ ,  $A_{399}$ , and  $A_{510}$ , respectively, using the multimode reader (Synergy HTX – Biotek) and subsequently calculating their concentrations from standard curves of  $\text{KH}_2\text{PO}_4$ , KCl,  $\text{ZnSO}_4$ , and ferrous ammonium sulfate, respectively.

The potato tuber nutrient contents were evaluated per plant from single well-developed tubers. The tubers were surface-sterilized using 2% sodium hypochlorite and rinsed four times with sterile distilled water. Next, they were chopped into small pieces using a clean knife and dried in the oven (80 °C) for 5 days. Particle size reduction was performed by mechanically grinding, crushing, and milling them into fine amorphous powders. The P, Fe, and K in them were extracted using 50 mL of 2% acetic acid on 0.2 g of samples, followed by filtering (Miller 1995). The Mehlich III method was used to extract Zn in the powdered potato tuber samples (Tedesco et al. 1995). All sample extracts were subjected to quantification of P, K, Zn, and Fe by absorbance measurements using the multimode reader (Synergy HTX – Biotek), and the respective concentrations were obtained using the standard graphs as previously described for soil analysis. The analysis of total %N in potato samples was performed using the micro-Kjeldahl process (Bremmer and Mulvaney 2015), and their crude protein contents were estimated using Eq. 6 based on the assumption that N constitutes 16% of protein (AOAC 1995).

$$\text{Crude protein content (\%)} = \text{micro - Kjeldahl N content (\%)} \times 6.25 \quad (6)$$

## Statistical Analysis

All statistical analyses were performed using the XLSTAT (Version 2.3, Adinsoft) at a 95% level of confidence. The Shapiro-Wilk test was used to test for normality of data and multiple comparisons of variances were performed using Multivariate Analysis of Variance (MANOVA). Variables with significantly different means were subjected to post hoc analysis using Tukey's Honest Significant Difference (HSD) test. Spearman's correlation was used to evaluate relationships between potato nutrient contents, rhizosphere soil properties, and potato biometrics in the screen house experiment. The percent increase/decrease in levels of different response/dependent variables was calculated from the field experiments using Eq. 7 to assess the differences between treatment and control experiments.

$$\frac{\text{Treatment} - \text{Control}}{\text{Treatment}} \times 100\% \quad (7)$$

---

## Results

### The Cultural, Microscopic, Biochemical, and Carbohydrate Utilization Properties of the Potato Rhizobacterial Isolates

The cultural, microscopic, biochemical, and the CHO utilization properties of the potato rhizobacterial isolates are displayed in Table 2. All colonies were round in form except for *E. tabaci* MPUS2 and *S. liquefaciens* KIBS5 which were spreading in form and *C. freundii* MWANS4 which had a rhizoid appearance. They portrayed different colors, textures, and margins and most were opaque. All were rod-shaped



<i>Ribose</i>	+	+	+	+	+	+	+	+	-	+	+	+	+
<i>Trehalose</i>	+	+	+	+	+	+	+	+	+	+	+	+	+
<i>Cellulose</i>	+	-	+	+	+	+	+	+	-	+	+	+	+
<i>Ducitol</i>	+	+	+	+	+	+	+	-	+	+	+	+	+
<i>Sorbitol</i>	-	-	+	+	+	+	-	-	+	+	+	+	+

<sup>a</sup>*Enterobacter tabaci* LUTS2

<sup>b</sup>*Enterobacter tabaci* MPUS2

<sup>c</sup>*Citrobacter freundii* MWANS4

<sup>d</sup>*Serratia marcescens* NGAS9

<sup>e</sup>*Serratia liquefaciens* KIBS5

<sup>f</sup>*Klebsiella grimontii* LUTS1

<sup>g</sup>*Enterobacter asburiae* MWAKS5

<sup>h</sup>*Enterobacter tabaci* MATS3

<sup>i</sup>*Klebsiella oxytoca* MWAKS1

<sup>j</sup>*Enterobacter ludwigii* BUMS1

<sup>k</sup>Methyl Red test for organic acids

<sup>l</sup>Test for production of hydrogen sulfide

<sup>m</sup>Oxidative fermentative test

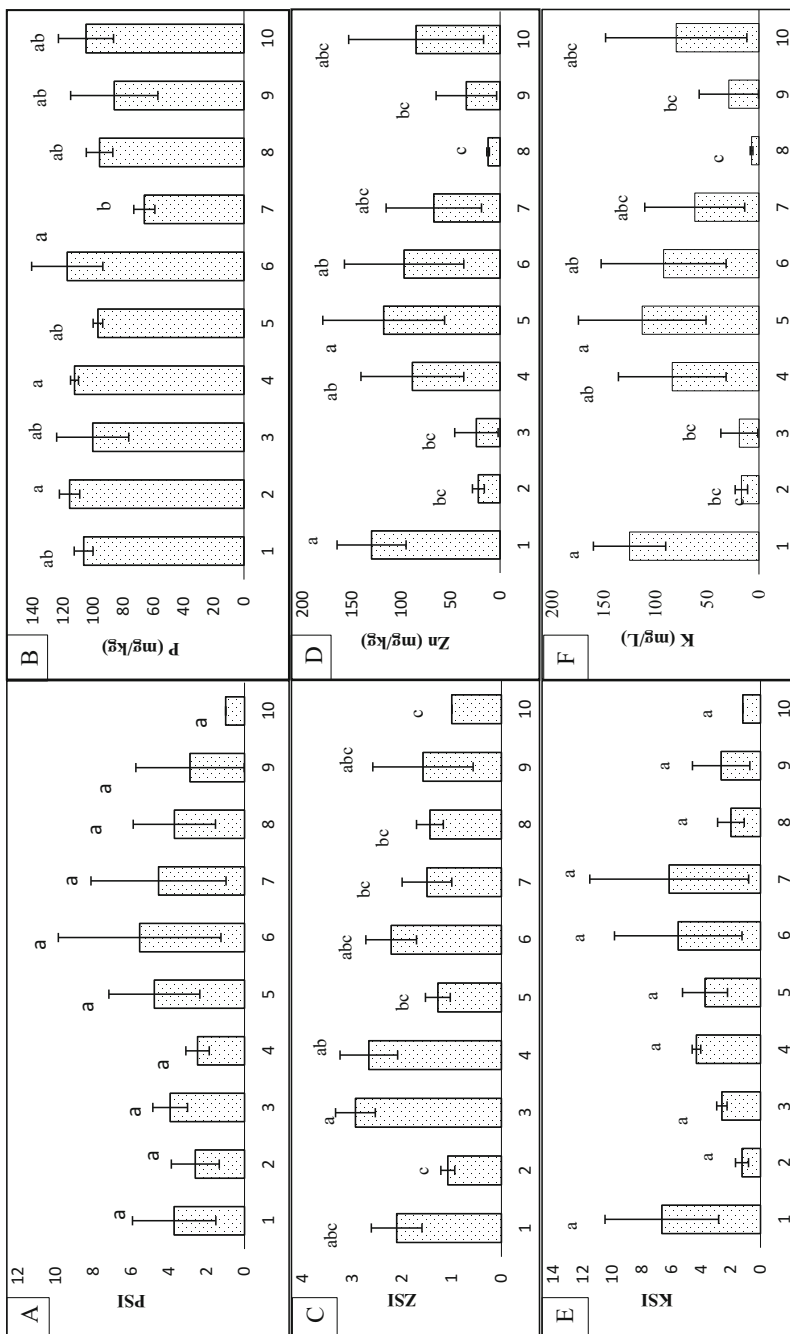


Fig. 1 (continued)

and Gram-negative. Similarly, all strains were motile except for *S. marcescens* NGAS9, *E. asburiae* MWAKS5, and *K. oxytoca* MWAKS1 and all were MR-positive except for *C. freundii* MWANS4, *E. asburiae* MWAKS5, *K. oxytoca* MWAKS1, and *E. ludwigii* BUMS1.

Except for *E. asburiae* MWAKS5, the rest of the studied isolates were catalase-positive, with some isolates like *E. ludwigii* BUMS1, *K. oxytoca* MWAKS1, *S. liquefaciens* KIBS5, and *S. marcescens* NGAS9 exhibiting strong catalase activities than the rest of the isolates. Half of the isolates exhibited H<sub>2</sub>S production abilities but indole production and O-F tests were positive for all of them. *Klebsiella oxytoca* MWAKS1, *K. grimontii* LUTS1, and *S. marcescens* NGAS9 metabolized all the tested sugars. *Enterobacter ludwigii* BUMS1, *E. tabaci* MATS3, *E. asburiae* MWAKS5, *C. freundii* MWANS4, *E. tabaci* MPUS2, and *E. tabaci* LUTS2 could not metabolize lactose. Additionally, *E. tabaci* MPUS2 and *E. tabaci* MATS3 could not metabolize cellobiose, *E. tabaci* LUTS2, *E. tabaci* MPUS2, and *S. liquefaciens* KIBS5 could not metabolize sorbitol and *S. liquefaciens* KIBS5 could not metabolize dulcitol.

### ***In vitro* Plant Growth Promoting Abilities of the Potato Rhizobacterial Isolates**

The results of *in vitro* solubilization of P, Zn, and K by the 10 potato rhizobacterial isolates are portrayed in Fig. 1a–f. Significant differences among the isolates were observed for ZSI in the qualitative assays and quantities of solubilized P ( $p = 0.026$ ), Zn ( $p = 0.031$ ), and K ( $p = 0.031$ ) in the quantitative assays. However, no significant differences were noted for PSI ( $p = 0.885$ ) and KSI ( $p = 0.524$ ) in the qualitative assays. The averages of PSI, ZSI, and KSI were  $3.628 \pm 0.420$ ,  $1.783 \pm 0.764$ , and  $3.619 \pm 3.563$ , respectively, while those for quantities of solubilized P, Zn, and K were  $100.33 \pm 19.90 \text{ mg L}^{-1}$ ,  $67.897 \pm 55.46 \text{ mg L}^{-1}$ , and  $62.897 \pm 55.46 \text{ mg L}^{-1}$ , respectively. The best P solubilizers were *E. tabaci* LUTS 2, *E. tabaci* MPUS2, and *S. liquefaciens* KIBS5 which recorded average quantities of 115.88, 112.59, and 117.43  $\text{mg L}^{-1}$  of solubilized P, respectively. Similarly, *S. marcescens* NGAS9, with average ZSI of 2.94 and *E. ludwigii* BUMS1, with an average of 130.26  $\text{mg L}^{-1}$  of solubilized Zn, exhibited the best Zn solubilization abilities in the qualitative and quantitative



**Fig. 1** *In vitro* nutrient solubilization abilities of the potato rhizobacterial isolates. On the X axes, 1 = *Enterobacter ludwigii* BUMS1, 2 = *Enterobacter tabaci* LUTS2, 3 = *Serratia marcescens* NGAS9, 4 = *Enterobacter tabaci* MPUS2, 5 = *Citrobacter freundii* MWANS, 6 = *Serratia liquefaciens* KIBS5, 7 = *Klebsiella grimontii* LUS1, 8 = *Enterobacter asburiae* MWAKS5, 9 = *Klebsiella oxytoca* MWAKS1 and 10 = *Enterobacter tabaci* MATS3. (a): Phosphorus solubilization index (b): Quantity of solubilized Phosphorus (c): Zinc solubilization index (d): Quantity of solubilized Zinc (e): Potassium solubilization index (f): Quantity of solubilized potassium. Values are means of three replicates and bars with similar letters are not significantly different (ANOVA + Tukey's HSD;  $P < 0.05$ )



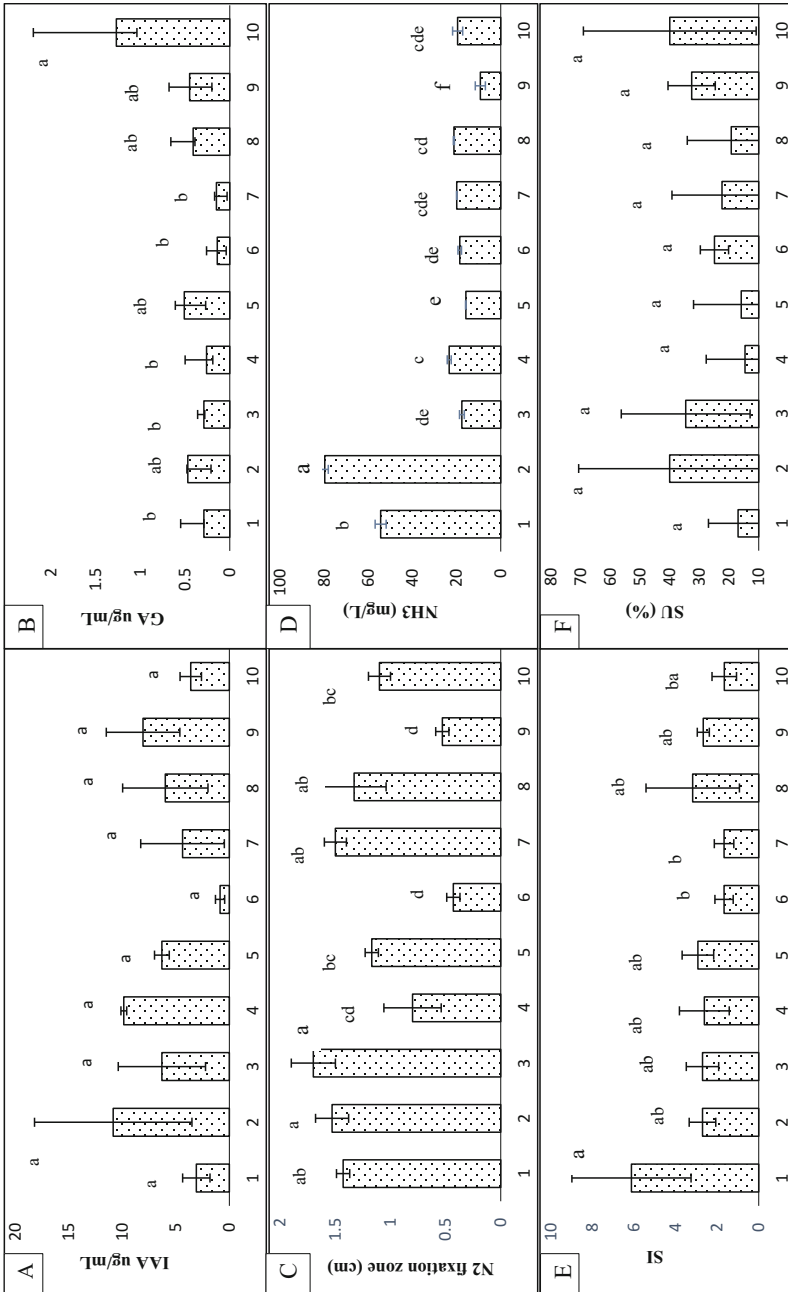


Fig. 2 (continued)

assays, respectively. Only two isolates, *C. freundii* MWANS4 and *E. ludwigii* BUMS1 exhibited good K solubilization abilities in the quantitative assays by yielding an average of 112.98 and 125.26 mg L<sup>-1</sup> of solubilized K, respectively.

The quantity of IAA produced by the potato isolates *in vitro* was not significantly different ( $p = 0.080$ ) (Fig. 2a). Nevertheless, *E. tabaci* LUTS2 yielded the highest quantity of IAA (10.86 µg mL<sup>-1</sup>) and the average quantity of IAA produced by all the isolates was  $5.57 \pm 4.51$  µg mL<sup>-1</sup>. Interestingly, the isolates exhibited significantly different ( $p = 0.027$ ) abilities to produce GA (Fig. 2b). The average quantity of GA produced by the isolates was however only  $0.423 \pm 0.420$  µg mL<sup>-1</sup> and the best GA producer was *E. tabaci* MATS3 with an average of 1.27 µg mL<sup>-1</sup>. The isolates exhibited significantly different ( $p < 0.0001$ ) N<sub>2</sub>-fixation abilities *in vitro* (Fig. 2c, d). The average N<sub>2</sub> fixation zones and quantities of ammonia (NH<sub>3</sub>) recorded for them were  $1.153 \pm 0.440$  cm and  $27.97 \pm 21.09$  mg L<sup>-1</sup>, respectively. *Serratia marcescens* NGAS9 which recorded an average N<sub>2</sub> fixation zone of 1.70 cm and *E. ludwigii* BUMS1 with an average of 79.84 mg L<sup>-1</sup> produced NH<sub>3</sub> yielded the best results from the two tests used to assess for *in vitro* N<sub>2</sub> fixation. The isolates exhibited significant differences ( $p = 0.021$ ) with regards to the SI averages (Fig. 2e), but no significant differences ( $p = 0.584$ ) were observed with regards to the SU averages (Fig. 2f). The average SI and SU recorded for the isolates were  $2.79 \pm 1.66$  and  $26.14 \pm 18.25\%$ , respectively. The highest average SI of 6.13 was yielded by *E. ludwigii* BUMS1 and the rest of the isolates yielded significantly lower SI averages ranging from 1.67 to 2.71.

## Effects of the Rhizobacterial Treatments on Potato Growth Parameters and Rhizobacterial Soils in the Screen House Experiment

The effects of rhizobacterial treatments on various growth parameters related to potato growth in the screen house experiment are shown in Table 3. Although the DTE averages were not significantly different for the different treatments in this experiment ( $p = 0.960$ ), treatment with some rhizobacteria such as *K. oxytoca* MWAKS1, *E. tabaci* LUTS2, and *E. asburiae* MWAKS5 still resulted in DTE reduction by 7.53%, 3.41%, and 7.53%, respectively. Treatment of the potato seed tubers with the various rhizobacterial isolates significantly ( $p = 0.027$ ) improved the DTF of treated plants in comparison to the untreated controls which recorded the



**Fig. 2** Effects of rhizobacterial treatments on growth parameters of potted potato plants. On the X axes, 1 = *Enterobacter ludwigii* BUMS1, 2 = *Enterobacter tabaci* LUTS2, 3 = *Serratia marcescens* NGAS9, 4 = *Enterobacter tabaci* MPUS2, 5 = *Citrobacter freundii* MWANS, 6 = *Serratia liquefaciens* KIBS5, 7 = *Klebsiella grimontii* LUS1, 8 = *Enterobacter asburiae* MWAKS5, 9 = *Klebsiella oxytoca* MWAKS1 and 10 = *Enterobacter tabaci* MATS3. (a): Quantity of Gibberellic acids (b): Quantity of indole-3-acetic acid (c): Nitrogen fixation zone (d): Quantity of ammonia (e): Siderophore production index (f): Siderophore production units. Values are means of three replicates and beans with similar letters within the same chart are not significantly different (ANOVA + Tukey's HSD;  $P < 0.05$ )

**Table 3** Effects of rhizobacterial treatments on potato biometric parameters

Treatment	DTE <sup>a</sup>	DTF <sup>b</sup>	Tuber no <sup>c</sup>	Tuber weight (g) <sup>d</sup>	Tuber diameter (cm) <sup>e</sup>	Tuber size (cm <sup>3</sup> ) <sup>f</sup>	Shoot length <sup>g</sup>	Shoot weight <sup>h</sup>
S1	10.00 (0.00) a	36.67 (-25.44) ab	14.67 (40.90) a	19.93 (91.21) a	3.87 (44.96) a	40.08 (80.20) a	38.00 (53.50) a	13.26 (82.50) a
S2	10.00 (0.00) a	43.33 (-6.16) ab	14.33 (39.50) a	5.39 (68.46) b	2.57 (17.12) bcd	9.13 (43.92) a	37.67 (53.09) a	18.14 (87.10) a
S3	9.333 (-7.53) a	42.00 (-9.52) ab	12.00 (27.75) a	7.40 (77.03) ab	3.53 (39.66) ab	24.67 (79.25) a	36.00 (50.92) a	5.07 (54.24) a
S4	10.00 (0.00) a	36.67 (-25.44) ab	11.67 (25.71) a	4.74 (64.14) b	3.27 (34.86) abc	18.47 (72.28) a	46.33 (61.86) a	6.94 (66.57) a
S5	9.67 (-3.41) a	36.67 (-25.44) ab	12.67 (31.57) a	7.68 (77.86) ab	2.33 (8.58) cd	6.69 (23.47) a	28.33 (37.63) a	19.85 (88.12) a
S6	9.33 (-7.53) a	39.33 (-19.96) ab	12.00 (27.75) a	5.39 (68.46) b	2.87 (25.78) abcd	13.43 (64.27) a	29.00 (39.07) a	8.75 (73.49) a
S7	10.00 (0.00) a	34.67 (-32.68) b	11.33 (23.48) a	7.28 (76.65) ab	2.67 (20.22) bcd	12.83 (60.09) a	28.00 (36.89) a	3.48 (33.33) a
S8	10.00 (0.00) a	38.00 (-21.05) ab	10.00 (13.30) a	2.27 (36.57) b	2.37 (10.13) cd	7.00 (26.86) a	29.00 (39.07) a	3.46 (34.83) a
S9	10.00 (0.00) a	36.67 (-25.44) ab	10.00 (13.30) a	4.30 (60.47) b	2.17 (1.84) d	5.52 (7.25) a	37.67 (36.14) a	3.01 (22.92) a
S10	10.00 (0.00) a	40.67 (-13.11) ab	8.667 (0.00) a	3.87 (56.07) b	2.20 (3.18) d	5.67 (9.70) a	17.00 (-3.94) a	2.19 (-5.94) a

Control <sup>i</sup>	10.667 a	46,000 a	8,667 a	1,703 b	2.133 d	5.117 a	17.667 a	2.323 a
p value	0.960	0.027	0.121	0.010	0.027	0.189	0.169	0.216
Significant	No	Yes	No	Yes	Yes	No	No	No

S1: *Serratia marcescens* NGAS9, S2: *Serratia liquefaciens* KIBS5, S3: *Klebsiella oxytoca* MWAKS1, S4: *Enterobacter tabaci* MATS3, S5: *Enterobacter tabaci* LUTS2, S6: *Enterobacter asburiae* MWAKS5, S7: *Citrobacter freundii* MWANS4, S8: *Enterobacter tabaci* MPUS2, S9: *Klebsiella grimontii* LUTS1, S10: *Enterobacter ludwigii* BUMS1

Values are means of three replicates with (%) increase relative to the control in parenthesis. Means with similar letters within the same columns are not significantly different (ANOVA + Tukey's HSD;  $p < 0.05$ )

<sup>a</sup>Number of days to emergence

<sup>b</sup>Number of days to flowering

<sup>c</sup>Average number of tubers

<sup>d</sup>Average weight of tubers

<sup>e</sup>Average diameter of tubers

<sup>f</sup>Average size of tubers calculated from the average diameters

<sup>g</sup>Average shoot lengths

<sup>h</sup>Average shoot weights

<sup>i</sup>Un-inoculated control experiment

highest DTF of 46. The rhizobacterial treatments reduced the average DTF of potato plants by approximately 6–33%. The DTF reduction by *C. freundii* of 32.68% was significantly higher than all other rhizobacterial treatments.

Although the number of tubers was not significantly different ( $P = 0.121$ ) across the different rhizobacterial treatments and the un-inoculated control, the rhizobacterial treatments still resulted in crops with increased tuber yields above the control which recorded an average tuber number of 8.67. The greatest average number of tubers of 14.67 was observed from the treatment with *S. marcescens* NGAS9 corresponding to a 91.21% increase relative to the control plants. Significant differences were observed for tuber weight ( $p = 0.010$ ) and diameter ( $p = 0.027$ ) among the different rhizobacterial treatments and the uninoculated control plants.

The highest average tuber weight of 19.93 g corresponding to a 91.21% increase above the control was recorded for potato plants from the treatment with *S. marcescens* NGAS9. This particular treatment also yielded the largest tuber diameter of 3.87 cm corresponding to a 44.96% increase over the control which recorded an average tuber diameter of 2.13 cm.

No significant differences ( $p = 0.189$ ) were observed for tuber sizes for the different treatments and the control experiment. However, treatment with *S. marcescens* NGAS9 produced an average tuber size of 40.08 cm<sup>3</sup> corresponding to an increase of 87.23% above control treatments. The average shoot lengths of potato plants observed for different rhizobacterial treatments in this study were not significantly different ( $p = 0.169$ ). However, all rhizobacterial treatments except for *E. ludwigii* BUMS1 resulted in increased shoot lengths of the potato plants by between 36% and 54% relative to the un-inoculated controls. The treatment with *E. tabaci* MATS3 gave the maximum shoot weight of 46.33 and the highest increment of 61.86% relative to the un-inoculated control. Interestingly, treatment with *E. ludwigii* BUMS1, though not significant, resulted in shoots with lower weights and lengths in comparison to the un-inoculated control. Similarly, the average shoot weights of potato plants observed for different rhizobacterial treatments in this study were not significantly different ( $p = 0.126$ ). However, the treatments still resulted in increased shoot weights of potato plants by up to 82% relative to the control experiments where the average shoot weight was 2.32 g.

The properties of potato rhizospheric soils from the screen house experiment are provided in Table 4. Significant differences ( $p < 0.05$ ) were among the rhizobacterial treatments and the un-inoculated control for all the studied soil properties except for Fe ( $p = 0.077$ ), P ( $p = 0.109$ ), and pH ( $p = 0.493$ ). The treatment with *E. tabaci* MPUS2 resulted in the highest OM content of 3.56% corresponding to a 60% increment over the un-inoculated control. *Klebsiella grimontii* LUTS1 also yielded the best results in terms of EC, salts, and K contents with averages of 1467.33  $\mu\text{S cm}^{-1}$ , 0.51%, and 31.79  $\text{mg kg}^{-1}$ , respectively, corresponding to increments of 48.8%, 49.7%, and 75.3%, respectively, above the un-inoculated control. Treatment of potato plants with *E. asburiae* MWAKS5 also yielded significantly higher averages of OM (2.22%), OM (3.83%), and Zn (92.28  $\text{mg kg}^{-1}$ ) corresponding to increments of 68.3%, 68.4%, and 66.7%, respectively, over the un-inoculated control.

**Table 4** Effects of rhizobacterial treatments on physicochemical properties of potato rhizospheric soils

Treatment	OC (%) <sup>a</sup>	OM (%) <sup>b</sup>	pH	EC ( $\mu\text{S cm}^{-1}$ ) <sup>c</sup>	Salts (%) <sup>d</sup>	N (%) <sup>e</sup>	P ( $\text{mg kg}^{-1}$ ) <sup>f</sup>	Zn ( $\text{mg kg}^{-1}$ ) <sup>g</sup>	K ( $\text{mg kg}^{-1}$ ) <sup>h</sup>	Fe ( $\text{mg kg}^{-1}$ ) <sup>i</sup>
S1	1.91 (63.4) ab	3.29 (63.2) abc	8.04 (-0.4) a	742.00 (-1.2) ab	0.26 (0.0) ab	0.16 (62.5) ab	346.50 (39.3) a	74.20 (56.4) ab	9.58 (16.0) bc	0.86 (98.8) a
S2	1.09 (35.8) ab	1.31 (7.6) d	8.25 (2.2) a	384.33 (-95.4) b	0.14 (-85.7) b	0.07 (14.3) cd	211.47 (0.6) a	54.44 (40.6) ab	14.14 (44.4) bc	1.31 (99.5) a
S3	1.61 (56.5) ab	1.63 (25.8) cd	7.70 (-4.8) a	781.67 (3.9) ab	0.27 (3.0) ab	0.08 (25.0) bcd	282.98 (25.7) a	59.76 (45.9) ab	12.08 (34.9) bc	1.70 (99.4) a
S4	2.04 (65.7) ab	3.51 (65.5) ab	8.12 (0.6) a	459.67 (-63.4) b	0.16 (-62.5) b	0.18 (66.7) a	308.78 (31.9) a	69.23 (53.3) ab	14.71 (46.6) bc	0.86 (99.5) a
S5	2.03 (65.4) ab	3.50 (65.4) ab	8.01 (-0.8) a	771.00 (2.6) ab	0.27 (3.7) ab	0.18 (66.7) a	332.09 (36.7) a	70.41 (54.0) ab	13.07 (39.9) bc	1.489 (99.5) a
S6	2.22 (68.3) a	3.83 (68.4) a	8.11 (0.6) a	581.00 (-29.3) ab	0.20 (-30.0) ab	0.19 (68.4) a	337.99 (37.8) a	97.28 (66.7) a	11.11 (29.3) bc	0.64 (99.3) a
S7	1.98 (64.7) ab	3.42 (64.5) abc	7.70 (-4.8) a	720.67 (-4.2) ab	0.25 (50.0) ab	0.17 (64.7) a	287.83 (27.0) a	77.51 (58.3) ab	13.50 (41.8) bc	0.78 (99.5) a
S8	2.07 (66.2) a	3.56 (66.0) a	5.97 (-35.2) a	755.67 (0.6) ab	0.267 (3.7) ab	0.18 (66.7) a	342.87 (38.6) a	51.88 (37.6) ab	10.09 (22.1) bc	0.89 (99.0) a
S9	1.35 (48.2) ab	1.75 (30.9) bcd	7.48 (-7.9) a	1467.33 (48.8) a	0.51 (49.0) a	0.15 (60.0) abc	331.44 (36.6) a	47.81 (33.3) b	31.79 (75.3) a	0.71 (99.7) a
S10	1.41 (50.4) ab	1.28 (5.5) d	7.91 (-2.02) a	321.33 (-133.7) b	0.11 (-136.4) b	0.06 (0.0) d	356.32 (41.0) a	67.10 (51.8) ab	16.71 (53.0) bc	0.50 (99.6) a

(continued)

Table 4 (continued)

Treatment	OC (%) <sup>a</sup>	OM (%) <sup>b</sup>	pH	EC ( $\mu\text{S cm}^{-1}$ ) <sup>c</sup>	Salts (%) <sup>d</sup>	N (%) <sup>e</sup>	P ( $\text{mg kg}^{-1}$ ) <sup>f</sup>	Zn ( $\text{mg kg}^{-1}$ ) <sup>g</sup>	K ( $\text{mg kg}^{-1}$ ) <sup>h</sup>	Fe ( $\text{mg kg}^{-1}$ ) <sup>i</sup>
Control <sup>j</sup>	0.704 b	1.214 d	8.073 a	751.000 ab	B 0.263 ab	0.061 d	21 0.248 a	32.357 b	7.860 c	0.217 a
p value	0.010	0.010	0.493	0.041	0.040	0.007	0.109	0.011	0.001	0.077
Significant	Yes	Yes	No	Yes	Yes	Yes	No	Yes	Yes	No

S1: *Serratia marcescens* NGAS9, S2: *Serratia liquefaciens* KIBS5, S3: *Klebsiella oxytoca* MWAKS1, S4: *Enterobacter tabaci* MATS3, S5: *Enterobacter tabaci* LUTS2, S6: *Enterobacter asburiae* MWAKS5, S7: *Citrobacter freundii* MWANS4, S8: *Enterobacter tabaci* MPUS2, S9: *Klebsiella grimontii* LUTS1, S10: *Enterobacter ludwigii* BUMS1

Values are means of three replicates with (%) increase relative to the control in parenthesis. Means with similar letters within the same columns are not significantly different (ANOVA + Tukey's HSD;  $p < 0.05$ )

<sup>a</sup>Percent organic carbon

<sup>b</sup>Percent organic matter

<sup>c</sup>Electrical conductivity (EC)

<sup>d</sup>Percent salts calculated from EC

<sup>e</sup>Percent nitrogen

<sup>f</sup>Extractable phosphorus

<sup>g</sup>Extractable zinc

<sup>h</sup>Extractable potassium

<sup>i</sup>Extractable iron

<sup>j</sup>Un-inoculated control experiment

Except for pH, EC, and salt contents, where some treatments resulted in reduced contents and others, increased contents in rhizospheric soils of the treated potato plants, the quantities of the rest of the soil properties increased as a result of the rhizobacterial treatments. Although no significant differences ( $p = 0.077$ ) were noted among the potato rhizobacterial treatments and the uninoculated control with regards to Fe contents of the rhizospheric soils, all rhizobacterial treatments resulted in increased Fe contents of between 99.0% and 99.8%. The effects of different rhizobacterial treatments on the nutrient concentration in potato tubers in the screen house experiment are provided in Table 5.

**Table 5** Effects of rhizobacterial treatments on physicochemical properties of potato nutrient contents

Treatment	Nitrogen (%)	Protein (%)	Phosphorus (mg kg <sup>-1</sup> )	Potassium (mg kg <sup>-1</sup> )	Iron (mg kg <sup>-1</sup> )	Zinc (mg kg <sup>-1</sup> )
S1	1.05 (87.6) a	6.55 (87.1) a	2363.13 (93.1) a	1051.29 (53.7) bc	0.59 (62.7) ab	1946.68 (91.9) cd
S2	0.91 (85.7) a	5.69 (85.4) a	2052.73 (92.1) a	1341.95 (63.8) b	1.07 (79.4) ab	4101.05 (96.2) abc
S3	0.90 (85.4) ab	5.62 (85.2) ab	2028.50 (92.0) ab	1489.33 (67.4) b	0.95 (76.8) ab	1553.80 (90.0) cd
S4	1.00 (86.9) a	6.25 (86.7) a	2256.39 (92.8) a	2741.86 (82.3) a	1.50 (85.3) ab	6429.97 (97.6) a
S5	0.45 (71.11) bc	2.81 (70.5) bc	1012.16 (83.9) bc	1430.58 (66.0) b	6.63 (96.7) a	2580.98 (94.0) bcd
S6	0.99 (86.9) a	6.21 (86.6) a	2240.02 (92.7) a	1266.93 (61.6) bc	0.52 (57.7) ab	4130.45 (96.2) abc
S7	0.34 (61.8) c	2.14 (61.2) c	770.51 (78.9) c	2327.07 (79.1) a	1.97 (88.8) ab	5629.40 (97.2) ab
S8	0.85 (84.7) ab	5.27 (84.3) ab	1901.46 (91.4) ab	982.14 (50.5) bc	0.57 (61.4) ab	872.16 (82.1) cd
S9	0.20 (35.0) c	1.22 (32.0) c	441.12 (61.1) c	740.97 (34.4) bc	3.53 (93.8) ab	1166.55 (86.6) cd
S10	0.83 (84.3) ab	5.16 (83.9) ab	1860.86 (91.3) ab	947.85 (48.7) bc	0.68 (67.7) ab	1653.20 (90.6) cd
Control <sup>a</sup>	0.133 c	0.833 c	162.677 c	486.328 c	0.216 b	155.947 d
p value	< 0.0001	< 0.0001	< 0.0001	< 0.0001	0.050	< 0.0001
Significant	Yes	Yes	Yes	Yes	Yes	Yes

S1: *Serratia marcescens* NGAS9, S2: *Serratia liquefaciens* KIBS5, S3: *Klebsiella oxytoca* MWAKS1, S4: *Enterobacter tabaci* MATS3, S5: *Enterobacter tabaci* LUTS2, S6: *Enterobacter asburiae* MWAKS5, S7: *Citrobacter freundii* MWANS4, S8: *Enterobacter tabaci* MPUS2, S9: *Klebsiella grimontii* LUTS1, S10: *Enterobacter ludwigii* BUMS

Values are means of three replicates with % increase relative to the control in parenthesis. Means with similar letters within the same columns are not significantly different (ANOVA + Tukey's HSD;  $p < 0.05$ )

<sup>a</sup>Un-inoculated control experiment



All the studied nutrients in the potato tubers were significantly different ( $p < 0.05$ ) across the different rhizobacterial treatments and the un-inoculated control. The greatest N, protein, and P increments (>85%) were observed for the treatments with *S. marcescens* NGAS9, *E. tabaci* MATS3, and *E. asburiae* MWAKS5. For K, *E. tabaci* MWATS 3 yielded the highest average of 2741.86 mg kg<sup>-1</sup> corresponding to an 82.3% increment over the un-inoculated control for which the average K content was 486.33 mg kg<sup>-1</sup>. Similar results were observed for Fe quantity in potato tubers where the same treatment resulted in tubers with an average Fe content of 6.63 mg kg<sup>-1</sup> corresponding to a 96.7% increment over the control which recorded an average Fe content of 0.126 mg kg<sup>-1</sup>. Interestingly, the rhizobacterial treatments resulted in tubers with improved Zn content to a great extent over the un-inoculated controls by between 90% and 97%. The highest Zn content of 6429.97 mg kg<sup>-1</sup> was recorded for the treatment with *E. tabaci* MATS3, an increment of 97.6% over the control whose tubers had an average Zn content of 155.95 mg kg<sup>-1</sup>.

---

## Discussions

### Cultural, Microscopic, Biochemical, and Carbohydrate Utilization Properties of the Isolates

The rhizobacterial isolated exhibited a broad range of morphological features in terms of their colony forms, indicating their relative diversity. All isolates were Gram-negative, agreeing with other reports that that plant rhizospheres are predominantly colonized by Gram-negative bacterial communities. For instance, in a recent study by Mujahid et al. (2015), up to 90% of all studied rhizobacterial isolates from various crop fields, respectively, were also Gram-negative.

Only 3 out of the 10 potato rhizobacterial isolates in this study did not exhibit any form of motility in the MTM. Rhizobacterial motility is an important property that enables bacteria to reach the plant root exudates and flagella-driven chemotaxis is very critical for successful root colonization (Turnbull et al. 2001). Half of the isolates were MR-positive, indicating their ability to produce organic acids which are important in the solubilization of inorganic P (Adeleke et al. 2017). Similarly, the rhizobacterial isolates were all positive for catalase production and some isolates exhibited very strong catalase activities. Catalases are enzymes that act as defense mechanisms for bacteria to detoxify, neutralize, repair, or escape oxidative damages and bactericidal effects of reactive oxygen species like H<sub>2</sub>O<sub>2</sub> (Mumtaz et al. 2017). Except for *K. oxytoca* MWAKS1, all the isolates also exhibited citrate utilization which is thought to play a significant role in competitive root colonization and maintenance of bacteria in the rhizosphere (Turnbull et al. 2001).

Half of the potato rhizobacterial isolates exhibited H<sub>2</sub>S production. The reduction of sulfide and other sulfate compounds into H<sub>2</sub>S is thought to diminish sulfur availability in the soil for plants and is thus not a desirable trait for soil fertility (Choudhary et al. 2018). The isolates all exhibited indole-production in

tryptophan-amended cultures, showing their corresponding abilities to produce tryptophanases (Das et al. 2019). Similarly, the rhizobacterial isolates were all positive for the O-F test, indicating their saccharolytic nature which is an important trait for rhizosphere colonization.

The rhizobacterial isolates exhibited varying capacities to metabolize different CHO. A number of them were capable of metabolizing all the sugars but some could not metabolize lactose, sorbitol, and dulcitol. The rhizosphere is generally a nutrient-rich microenvironment due to the presence of rhizodeposits and root exudates with different chemical compositions (Kumar et al. 2018). This can explain the diverse ability of the isolates to utilize different substrates for growth as may be provided for in their natural environments. Substrate preference may confer certain selective advantages in the rhizosphere and multisubstrate utilization may enable rhizobacteria to diversify their nutrient sources for efficient rhizosphere colonization (Zahlina et al. 2018).

### ***In vitro* Plant Growth-Promoting Activities of the Potato Rhizobacterial Isolates**

The potato rhizobacterial isolates exhibited varying P, Zn, and K solubilization capacities. The average quantities of solubilized P ranged from 60.96 to 163.47 mg mL<sup>-1</sup> which is higher compared to previously reported averages for potato rhizobacterial isolates, for example, in studies by Naqqash et al. (2016) where the averages ranged from 30.71 to 141.23 mg L<sup>-1</sup>. The best P solubilizers were *E. tabaci* LUTS 2, *E. tabaci* MPUS2, and *S. liquefaciens* KIBS5 with average quantities of 115.88, 112.59, and 117.43 mg L<sup>-1</sup> of solubilized P, respectively. The solubilization of P is proposed to occur through acidification by organic acids and results in the production of di- and mono-basic phosphates which are the only plant-available P forms (Awais et al. 2019). The production of organic acids by the rhizobacterial strains in the present study was evidenced in the biochemical assays and can explain their P solubilization abilities and illustrate how valuable they can be in improving potato P nutrition.

*Serratia marcescens* NGAS9, with average ZSI of 2.94 and *E. ludwigii* BUMS1, with an average of 130.26 mg L<sup>-1</sup> of solubilized Zn exhibited the best Zn solubilization abilities in the qualitative and quantitative assays, respectively. Although Zn is a micronutrient, its adequate supply is required for proper potato yields (Vreugdenhil 2007). Since only a small portion of Zn occurs in plant-available forms in most soils, Zn solubilizing bacteria (ZSB) such as the ones identified in the present study have the potential of improving the Zn utilization in potato grown soils (Aloo et al. 2019).

Except for a few isolates, the K solubilization abilities of the potato rhizobacterial isolates followed similar trends to P and Zn solubilization abilities. Two isolates *C. freundii* MWANS4 and *E. ludwigii* BUMS1 particularly showed good K solubilization abilities in the quantitative assays by yielding averages of 112.98 and 125.26 mg L<sup>-1</sup> of solubilized K, respectively. Evidence suggests that about 98%

of K occurs in soils in fixed forms and only about 2% is available in plant-accessible forms (Meena et al. 2018). As such, efficient KSB such as the ones identified in the present study can significantly enhance potato K nutrition.

All the potato rhizobacterial isolates produced IAA in tryptophan-amended culture media similar to reports by Naqqash et al. (2016). Indole-3-acetic acid is a rhizobacterial PGP hormone that is important for the proliferation of lateral roots and root hairs and enhancement of plant mineral nutrients uptake (Kumar et al. 2018). The average IAA quantity produced by the isolates in the present study was  $5.57 \pm 4.51 \mu\text{g mL}^{-1}$ . In a recent study by Jadoon et al. (2019) in Pakistan, lower IAA average quantities of only  $2.09 \mu\text{g mL}^{-1}$  were reported but geographical differences could explain this variation. The isolates generally produced lesser quantities of GA with an average of only  $0.423 \pm 0.420 \mu\text{g mL}^{-1}$ . The best GA producer was *E. tabaci* MATS3 with an average of  $1.27 \mu\text{g mL}^{-1}$ . Unlike IAA, reports on rhizobacterial GA production are scanty (Amar et al. 2013), yet GA production is one of the rhizobacterial PGP mechanisms (Aloo et al. 2019).

The average  $\text{N}_2$ -fixation zones and quantities of  $\text{NH}_3$  were  $1.153 \pm 0.440 \text{ cm}$  and  $27.97 \pm 21.09 \text{ mg L}^{-1}$ , respectively. *Serratia marcescens* NGAS9, with an average  $\text{N}_2$  fixation zone of 1.70 cm and *E. ludwigii* BUMS1, with an average  $\text{NH}_3$  of  $79.84 \text{ mg L}^{-1}$  yielded the best results in this assay. The diazotrophic abilities of the potato rhizobacteria established in the present investigation indicate the critical role they could be playing in the potato rhizosphere. Although diazotrophy is a common trait in legume symbioses, nitrogenase genes are present in diverse bacterial taxa (Gyaneshwar et al. 2011). Such traits can be optimized and exploited to promote N nutrition in nonlegumes such as the potato using the diazotrophic strains identified in the present study.

The potato rhizobacterial isolates were all capable of producing siderophores which are important metabolites with a high affinity for binding Fe and promoting its availability to plants (Mhlongo et al. 2018). Interestingly, the present isolates showed higher siderophore production abilities than has been reported in other studies for potato rhizobacteria. For instance, the average SU obtained for the isolates in the present investigation was  $26.14 \pm 18.25\%$  while in studies by Pathak et al. (2019), potato rhizobacteria produced lower SU means ( $< 11.97\%$ ). Very few potato rhizobacteria have been associated with the siderophore production trait (Aloo et al. 2019), and these siderophore-producing rhizobacterial isolates are important candidates for potato biofertilization.

## Effects of the Rhizobacterial Treatments on Growth and Yield of Potted Potatoes

The present study also evaluated the effects of indigenous rhizobacterial treatments on various growth parameters of potted potato under screen house conditions. The results showed that most of the rhizobacterial treatments reduced the DTE and DTF of the potato plants by up to 7.35% and 32.68%, respectively, relative to the

un-inoculated controls. Increased germination rates and seedling vigor in plants following inoculation with beneficial rhizobacterial strains are advanced to occur as a result of phytohormone production that enhances growth by stimulating root elongation and development (Ahemad and Kibret 2014).

Except for the number and weight of tubers in the present study, the rest of the potato growth parameters were not significantly different across the treatments and the control treatment. Nevertheless, the rhizobacterial treatments still resulted in increased growth attributes of the plant. For instance, the potato shoot weights were increased by 22–88% upon rhizobacterial inoculation. Such results can also be attributed to the stimulation of root development and nutrient uptake by rhizobacterial PGP hormones (Kumar et al. 2018), whose production was also established for the present rhizobacterial inocula. Contrary to the expectation, *E. ludwigii* BUMS resulted in average potato shoot length and weight that were less than those of the un-inoculated control by 3.94% and 5.94%, respectively. The failure of rhizobacterial inocula to produce the desired results during *in planta* investigations is probably due to the inability to establish themselves in the rhizosphere (Istifadah et al. 2018).

The potato rhizospheric soils were also greatly influenced by the rhizobacterial treatments. Most treatments resulted in reduced pH levels relative to the control and increased N, P, K, Zn, and Fe contents in the potato rhizospheres, signifying rhizosphere acidification which is commonly associated with the solubilization of nutrients in the soil. The increased availability of N and P in the rhizospheric soils may be attributed to N<sub>2</sub> fixation and P solubilization by the rhizobacterial inocula as advanced by Sood et al. (2018). The Fe contents in the potato rhizospheric soils increased by up to 99.7% relative to the un-inoculated control following rhizobacterial inoculation, signifying the excellent Fe-mobilization abilities by the rhizobacterial inocula. The soil OC and OM contents also increased significantly for most of the treatments relative to the un-inoculated control.

The present study established that most of the rhizobacterial treatments resulted in tubers with increased nutrient contents, demonstrating improved nutrient uptake and accumulation by the treated plants. This can mostly be attributed to the multitrait inoculants used to treat the potato plants. For instance, the increased uptake and accumulation of N and P may have been due to increased fractions of the minerals in the rhizospheric soils mediated by the rhizobacterial treatments through N<sub>2</sub> fixation and P solubilization, respectively, as similarly observed in wheat by Sood et al. (2018). The inoculation of seed potato tubers with *S. marcescens* NGAS9, *S. liquefaciens* KIBS5, and *E. asburiae* MWAKS5 resulted in tubers with significantly higher N and protein contents, a clear indication of their efficient diazotrophic roles. Interestingly, the treatment of potato seed tubers with *C. freundii* MWANS4 and *K. grimontii* LUTS1, despite exhibiting N<sub>2</sub> fixation abilities in the *in vitro* studies, did not lead to significant increments on the average concentration of N and protein in the potato tubers relative to the un-inoculated control, probably due to the inability to establish adequately themselves in the potato rhizosphere.

## Conclusions

The study establishes the importance of indigenous rhizobacterial communities in the biofertilization of potato which can be exploited for its sustainable cultivation. The selected potato rhizobacterial isolates demonstrated efficient N<sub>2</sub>-fixing, P-solubilizing, and IAA, siderophores producing abilities. All these characteristics are important PGP traits and have been found effective in positively improving the growth of potted potato plants under screen house conditions. In sustainable crop production, the focus should not only be on increasing crop productivity but also the nutritional value of the food produced for food security. Apart from improving the potato growth parameters relative to the control, the rhizobacterial treatments also enhanced nutrient availability in the rhizospheric soils and improved the potato tuber nutrient contents. The studied isolates are, therefore, potential candidates in future field applications and sustainable cropping of potato in Tanzania.

## References

- Adeleke R, Mwangburuka C, Oboirien B (2017) Origins, roles and fate of organic acids in soils: a review. *S Afr J Bot* 108:393–406. <https://doi.org/10.1016/j.sajb.2016.09.002>
- Ahemad M, Kibret M (2014) Mechanisms and applications of plant growth promoting rhizobacteria: current perspective. *J King Saud Univ-Sci* 26:1–20. <https://doi.org/10.1016/j.jksus.2013.05.001>
- Aloo BN, Mbega ER, Makumba BA (2019) Rhizobacteria-based technology for sustainable cropping of Potato (*Solanum tuberosum* L.). *Potato Res*:1–21. <https://doi.org/10.1007/s11540-019-09432-1>
- Aloo BN, Mbega ER, Makumba BA, Hertel R, Danel R (2020) Molecular identification and in vitro plant growth-promoting activities of culturable Potato (*Solanum tuberosum* L.) rhizobacteria in Tanzania. *Potato Res*. <https://doi.org/10.1007/s11540-020-09465-x>
- Amar JD, Kumar M, Kumar R (2013) Plant growth promoting rhizobacteria (PGPR): an alternative of chemical fertilizer for sustainable, environment friendly agriculture. *Res J Agric For* 1:21–23
- AOAC (1995) Official methods of analysis, 16th edn. Association of Official Analytical Chemists, Washington, DC
- Awais M, Tariq M, Ali Q, Khan A, Ali A, Nasir IA, Husnain T (2019) Isolation, characterization and association among phosphate solubilizing bacteria from sugarcane rhizosphere. *Cytol Genet* 53:86–95. <https://doi.org/10.3103/S0095452719010031>
- Batista BD (2012) Promoção De Crescimento Em Milho (*Zea mays* L.) Por rizobactérias associadas à cultura do guaranazeiro (*Paullinia cupana* var. *sorbilis*). Dissertation, University of Sao Paulo
- Bremner JM, Mulvaney CS (2015) Nitrogen total. In: Page AL (ed) *Methods of soil analysis*, 2nd edn. American Society of Agronomy, Madison, pp 595–624
- Chaurasia S, Gupta AD (2014) *Handbook of water, air and soil analysis*. International Science Congress Association, Madhya Pradesh
- Chi CM, Wang ZC (2010) Characterizing salt-affected soils of Songnen plain using saturated paste and 1:5 soil to-water extraction methods. *Arid Land Res Manag* 24:1–11. <https://doi.org/10.1080/15324980903439362>
- Choudhary M, Ghasal P, Yadav R, Meena V, Mondal T, Bisht J (2018) Towards plant-beneficiary rhizobacteria and agricultural sustainability. In: Meena VS (ed) *Role of rhizospheric microbes in soil: volume 2: nutrient management and crop improvement*. Springer Nature, Singapore, pp 1–46

- Das S, Nurunnabi TR, Parveen R, Mou AN, Islam ME, Islam KMD, Rahman M (2019) Isolation and characterization of indole acetic acid producing bacteria from rhizosphere soil and their effect on seed germination. *Int J Curr Microbiol Appl Sci* 8:1237–1245
- Edi-Premona M, Moawad MA, Vlek PLG (1996) Effect of phosphate- solubilizing *Pseudomonas putida* on growth of maize and its survival in the rhizosphere. *Indones J Crop Sci* 11:13–23
- FAO (2008) International year of the potato: new light on a hidden treasure. Food and Agriculture Organization of the United Nations, Rome
- Fasim F, Ahmed N, Parsons R, Gadd GM (2002) Solubilization of zinc salts by a bacterium isolated from the air environment of a tannery. *FEMS Microbiol Lett* 213:1–6
- George H, Ed H (2011) A summary of N, P, and K research with tomato in Florida. The Institute of Food and Agricultural Sciences, University of Florida, Gainesville
- Goswami D, Dhandhukia PC, Patel P, Thakker JN (2014) Screening of PGPR from saline desert of Kutch: growth promotion in *Arachis hypogea* by *Bacillus licheniformis* A2. *Microbiol Res* 169: 66–75. <https://doi.org/10.1016/j.micres.2013.07.004>
- Gyaneshwar P, Hirsch AM, Moulin L, Chen WM, Elliot GN, Bontemps C, Santos PE, Gross E, Reis FB Jr, Sprent JI, Young PW, James EK (2011) Legume-nodulating betaproteobacteria: diversity, host range, and future prospects. *Mol Plant-Microbe Interact* 24:1276–1288. <https://doi.org/10.1094/mpmi-06-11-0172>
- Holbrook AA, Edge WLW, Bailey F (1961) Spectrophotometric method for determination of gibberellic acid in gibberellins. ACS, Washington, DC
- Hopkins BG, Hornek DA, MacGuidwin AE (2014) Improving phosphorus use efficiency through potato rhizosphere modification and extension. *Am J Potato Res* 91:161–174. <https://doi.org/10.1007/s12230-014-9370-3>
- Hugh R, Leifson E (1953) The taxonomic significance of fermentative versus oxidative metabolism of carbohydrates by various gram negative bacteria. *J Bacteriol* 66:24
- Istifadah N, Pratama N, Taqwm S, Sunarto T (2018) Effects of bacterial endophytes from potato roots and tubers on potato cyst nematode (*Globodera rostochiensis*). *Biodiversitas* 19:47–51. <https://doi.org/10.13057/biodiv/d190108>
- Jackson ML (1973) Soil chemical analysis, 2nd edn. Prentice Hall of India, New Delhi
- Jadoon S, Afzal A, Asad SA, Sultan T, Tabassum B, Umer M, Asif M (2019) Plant growth promoting traits of rhizobacteria isolated from Potato (*Solanum tuberosum* L.) and their antifungal activity against *Fusarium oxysporum*. *J Anim Plant Sci* 29:1026–1036
- Kumar A, Patel JS, Meena VS (2018) Rhizospheric microbes for sustainable agriculture: an overview. In: Meena V (ed) Role of rhizospheric microbes in soil. Springer Nature, Singapore, pp 1–31
- Manzira C (2011) Potato production handbook. Potato Seed Association, Harare
- Meena SV, Maurya BR, Meena SK, Mishra PK, Bisht JK, Pattanayak A (2018) Potassium solubilization: strategies to mitigate potassium deficiency in agricultural soils. *Glob J Biol Agric Health Sci* 7:1–3
- Mhlongo MI, Piater LA, Madala NE, Labuschagne N, Dubery IA (2018) The chemistry of plant-microbe interactions in the rhizosphere and the potential for metabolomics to reveal signaling related to defense priming and induced systemic resistance. *Front Plant Sci* 9:112. <https://doi.org/10.3389/fpls.2018.00112>
- Miller RO (1995) Extractable chloride nitrate orthophosphate and sulfate-sulfur in plant tissue: 2% acetic acid extraction. In: Kalra YP (ed) Handbook of reference methods for plant analysis. CRC Press, Boca Raton, pp 115–118
- Mujahid YT, Subhan SA, Wahab A, Masnoon J, Ahmed N, Abbas T (2015) Effects of different physical and chemical parameters on phosphate solubilization activity of plant growth promoting bacteria isolated from indigenous soil. *J Pharm Nutr Sci* 5:64–70
- Mumtaz MZ, Ahmad M, Jamil M, Hussain T (2017) Zinc solubilizing *Bacillus spp.* potential candidates for biofortification in maize. *Microbiol Res* 202:51–60
- Naqqash T, Hameed S, Imram A, Hanif MK, Majeed A, Van Elsas JD (2016) Differential response of potato toward inoculation with taxonomically diverse plant growth promoting rhizobacteria. *Front Plant Sci* 7:144. <https://doi.org/10.3389/fpls.2016.00144>

- Pathak D, Lone R, Khan S, Koul KK (2019) Isolation, screening and molecular characterization of free-living bacteria of potato (*Solanum tuberosum* L.) and their interplay impact on growth and production of potato plant under Mycorrhizal association. *Sci Hortic* 252:388–397. <https://doi.org/10.1016/j.scienta.2019.02.072>
- Payne SM (1993) Iron acquisition in microbial pathogenesis. *Trends Microbiol* 1:66–69. [https://doi.org/10.1016/0966-842X\(93\)90036-Q](https://doi.org/10.1016/0966-842X(93)90036-Q)
- Pradhan P (2016) KOH mount preparation: principle, procedure and observation. *Microbiology and Infectious Diseases*. <http://microbesinfo.com/2016/05/koh-mount-preparation-principle-procedure-and-observation/>. Accessed 28 Apr 2018
- Sambrook J, Russell DW (2001) *Molecular cloning: a laboratory manual*, 1st edn. Cold Spring Harbor Laboratory, New York
- Schwyn B, Neilands JB (1987) Universal chemical assay for the detection and determination of siderophores. *Anal Biochem* 60:47–56
- Simmons JS (1926) A culture medium for differentiating organisms of typhoid-colon aerogenes groups and for isolation of certain fungi. *J Infect Dis* 39:209
- Sindhu SS, Gupta SK, Dadarwal KR (1999) Antagonistic effect of *Pseudomonas spp.* on pathogenic fungi and enhancement of plant growth in green gram (*Vigna radiata*). *Biol Fertil Soils* 29:62–68
- Somasegaran P, Hoben HJ (1994) *Handbook for rhizobia. Methods in legume–rhizobium technology*. Springer, Heidelberg
- Sood G, Kaushal R, Chauhan A, Gupta S (2018) Indigenous plant-growth-promoting rhizobacteria and chemical fertilisers: impact on wheat (*Triticum aestivum*) productivity and soil properties in North Western Himalayan region. *Crop Pasture Sci* 69:460–468
- Tedesco MJ, Gianello C, Bissani CA, Bohnen H, Volkweiss SJ (1995) *Analysis of soil, plants and other materials*, 2nd edn. Federal University of Rio Grande do Sul, Porto Alegre
- Tran TS, Simard RR (1993) Mehlich III – extractable elements. In: Carter MR (ed) *Soil sampling and methods of analysis*, 2nd edn. CRC Press, Boca Raton, pp 43–49
- Turnbull GA, Morgan JAW, Whipps JM, Saunders JR (2001) The role of bacterial motility in the survival and spread of *Pseudomonas fluorescens* in soil and in the attachment and colonisation of wheat roots. *FEMS Microbiol Ecol* 36:21–23. <https://doi.org/10.1111/j.1574-6941.2001.tb00822.x>
- Vincent JM (1970) *A manual for the practical study of the root-nodule Bacteria*. Blackwell, Oxford, UK
- Vreugdenhil D (2007) *Potato biology and biotechnology – advances and perspectives*. Elsevier, Amsterdam
- Wahyudi AT, Astuti RP, Widyawati A, Meryandini AA, Nawagsih AA (2011) Characterization of *Bacillus sp.* strains isolated from rhizosphere of soybean plants for their use as potential plant growth promoting rhizobacteria. *J Microbiol Antimicrob* 3:34–40
- Walkley AJ, Black IA (1934) Estimation of soil organic carbon by the chromic acid titration method. *Soil Sci* 37:29–38
- Zahlina K, Louie K, Hao Z, Mansoori N, Da Rocha UN, Shi S, Cho H, Karaoz U, Loqué D, Powen BP, Firestone M, Northern TR, Brodie EL (2018) Dynamic root exudate chemistry and microbial substrate preferences drive patterns in rhizosphere microbial community assembly. *Nat Microbiol* 3:480

**Open Access** This chapter is licensed under the terms of the Creative Commons Attribution 4.0 International License (<http://creativecommons.org/licenses/by/4.0/>), which permits use, sharing, adaptation, distribution and reproduction in any medium or format, as long as you give appropriate credit to the original author(s) and the source, provide a link to the Creative Commons license and indicate if changes were made.

The images or other third party material in this chapter are included in the chapter's Creative Commons license, unless indicated otherwise in a credit line to the material. If material is not included in the chapter's Creative Commons license and your intended use is not permitted by statutory regulation or exceeds the permitted use, you will need to obtain permission directly from the copyright holder.







# Climate Change Adaptation Among Smallholder Farmers in Rural Ghana

# 72

Peter Asare-Nuamah and Athanasius Fonteh Amungwa

## Contents

Introduction .....	1498
Background .....	1498
Description of the Study Area and Methodology .....	1500
Study Area .....	1500
Research Methods .....	1500
Results and Discussion .....	1504
Adaptation Strategies Employed by Smallholder Farmers .....	1504
Predictors of Adaptation Strategies .....	1506
Predictors of Effective Adaptation .....	1507
Conclusion and Recommendations .....	1509
References .....	1511

## Abstract

Climate change has the potential to disrupt sustainable development initiatives, particularly in developing economies. A substantial body of literature reveals that developing economies are vulnerable to climate change, due to high dependency on climate-sensitive sectors, such as agriculture. In Ghana, a growing body of literature has revealed multiple adaptation strategies adopted by smallholder farmers to respond to and reduce climate change impacts. However, there is a dearth of literature on the effectiveness of adaptation strategies. This chapter explores the adaptation strategies of smallholder farmers and analyzed the predictors of effective adaptation. Through the technique of simple random

P. Asare-Nuamah (✉)

Institute of Governance, Humanities and Social Science, Pan African University, Soa, Cameroon

School of Sustainable Development, University of Environment and Sustainable Development, Somanya, Eastern Region, Ghana

A. F. Amungwa

Department of Sociology and Anthropology, Faculty of Social and Management Sciences, University of Buea, Buea, Cameroon

© The Author(s) 2021

W. Leal Filho et al. (eds.), *African Handbook of Climate Change Adaptation*,  
[https://doi.org/10.1007/978-3-030-45106-6\\_279](https://doi.org/10.1007/978-3-030-45106-6_279)

1497

sampling, 378 smallholder farmers were selected, and data was collected using a questionnaire survey. Descriptive and inferential statistics were performed using the SPSS software. The findings indicate that smallholder farmers adopt multiple adaptation strategies to reduce the impact of climate change. In addition, it is revealed that marital status, years of farming experience, knowledge of climate change, and education are significant predictors of adaptation. Moreover, the chapter found that marital status, weedicide application, change in staple food consumption, and planting of early-maturing crops are good predictors of effective adaptation. The chapter recommends the need to intensify adaptation strategies through agricultural extension programs and interventions that improve rural food security and livelihood. In addition, the chapter recommends strengthening the capacity of farmer organizations and rural institutions, particularly agricultural extension and advisory services.

---

**Keywords**

Climate change · Climate change adaptation · Effective adaptation · Smallholder farmers · Ghana

---

## Introduction

### Background

Climate change adaptation is defined as the adjustment in a system to respond to, recover from, and exploit opportunities, to reduce the impact of climate change. Adaptation has gained center stage in global development debates and discourse (IPCC 2018; World Bank 2018). The heightened attention of adaptation stems from the fact that climate change affects every component of the earth's system, particularly the biosphere and essential life-dependent resources (IPCC 2018). More importantly, climate change affects agriculture, thereby increasing the vulnerability of developing countries, whose economies are largely dependent on climate-sensitive sectors, including agriculture (AGRA 2014; IPCC 2018). According to the Intergovernmental Panel on Climate Change (IPCC) (2014, 2018), adaptation strategies are very important in developing economies in Africa and Asia, as the impact of climate change is already felt in extreme in these regions. For instance, climate-related disasters, such as floods and droughts, are predominant and extreme in Africa and Asia. Moreover, El Nino Southern Oscillation (ENSO) has been reported in Southern and West Africa, with prolonged dry season in Ghana (see Hirons et al. 2018; IPCC 2014, 2018). Consequently, a large body of literature has focused on examining the adaptation strategies adopted particularly by smallholder farmers to respond to these changes, with little or no attention on the effectiveness of adaptation as a conduit for food security and livelihood, which this chapter seeks to address. Dankelman (2010) asserts that adaptation strategies, particularly in developing countries, are ineffective and unsustainable, as they are practiced in a resource-

constrained environment, which calls for the need to examine effective adaptation strategies employed by smallholder farmers to enhance their food security and livelihood.

According to the European Environment Agency (EEA 2013), effective adaptation requires holistic, concrete, and process-based measures and approaches, whereas the German Development Agency (GIZ 2014) and IPCC (2007, 2014) argue that effective adaptation strategies have the potential to increase adaptive capacity and offset the negative impact of climate change, by decreasing sensitivity and exposure to climate change. Globally, farmers have adopted adaptation strategies to reduce vulnerability and respond to climate shocks and stresses, such as erratic rainfall, high temperature, flood, drought, and pests, among others (IPCC 2007, 2014, 2018). Adaptation strategies may be self-induced or externally planned; proactive, reactive, or concurrent; planned or spontaneous; and tactical or strategic. In addition, they may occur at different scales, such as local, regional, or international; by agents of adaptation including but not limited to individuals, communities, governments, the private sector, and non-governmental/civil society organizations (Antwi-Agyei et al. 2014a; Bryant et al. 2000; Smit et al. 2000; Smit and Skinner 2002; IPCC 2014). To ensure an effective adaptation, it is essential for adaptation agents to adopt planned adaptation behaviors, which are typical of disaster preparedness, as well as ensure effective response and recovery to disasters (World Bank 2018b).

A growing body of literature has revealed that farmers have adapted to climate change through multiple on-/off-farm adaptation strategies such as climate-smart agricultural practices, to enhance their livelihood and food security, which depend largely on the environment (Antwi-Agyei et al. 2014a; Gyampoh et al. 2009; Pearce and Ford 2015; Yaro et al. 2014). In Ghana, for instance, crop and livelihood diversification; pesticide, weedicide, and fertilizer application; water harvesting; and planting of early-maturing and drought-resistant crops have been reported in the literature (Antwi-Agyei et al. 2014a, b; Fosu-Mensah et al. 2012; Gyampoh et al. 2009; Osumanu et al. 2017; Yaro 2013a, b; Yaro et al. 2014). Nevertheless, Sarpong and Anyidoho (2012) argue that the adaptation strategies in Ghana are not effective due to poor policy environment, whereas Connolly-Boutin and Smit (2016) and the IPCC (2014) argue that poor natural resource management, low adaptive capacity, and poverty make the adaptation strategies ineffective in Africa.

According to the GIZ (2014) and Turner et al. (2003), entitlement, access, and endowment influence the adaptive capacity to climate change. This corroborates the assertion that the assets owned, used, and/or available to communities and households enable them to adapt to climate change (IPCC 2007, 2014). Similarly, studies have demonstrated that adaptation is dependent on multiple socioeconomic factors, such as age, gender, years of farming experience, assets, level of education, household size, and technology (Adu et al. 2018; Fosu-Mensah et al. 2012; Lopez-Ridaura et al. 2018). The present study aims to achieve the following objectives: explore adaptation strategies of smallholder farmers and predict factors that promote adaptation and effective adaptation. The rest of the paper presents the methods, results, and conclusion.

## Description of the Study Area and Methodology

### Study Area

The study was conducted in the Adansi North District, located in the Ashanti Region of Ghana on longitude 1.50 W, latitude 1.4 N and longitude 1.5 W, latitude 6.30 N. It covers about 853.63 km<sup>2</sup>, which is equivalent to 4.7% of the surface area of the region. It also has a total population of about 107,109, with 54,036 (50.5%) females and 53,055 (49.5%) males (GSS 2010, 2014). The dependency ratio in the district is high, with males found to be more dependent than females (GSS 2014). Located in the semi-equatorial climate, the district experiences high temperature and rainfall, with a mean rainfall of 1250 mm to 1750 mm and temperature of 27 °C. The district has bi-modal rainfall patterns, comprising of major and minor rainy seasons. February is the hottest month in the district, and agriculture is the major economic activity, employing about 77% of the labor force, followed by services (15%) and manufacturing (8%) (GSS 2014). The district has rich ochrosols, which favor agriculture and forest vegetation. The major food crops produced here include cassava, plantain, cocoyam, maize, yam, and cash crops, such as cocoa and oil palm. As a rural district, poverty, low income, and lack of access to basic socioeconomic assets are dominant in the district (GSS 2014).

### Research Methods

#### Study Site Selection and Sampling Method

A total of 15 communities from 7 operational areas were selected via multistage sampling techniques comprising of cluster and simple random sampling. The district has 15 operational areas which served as the clusters from which 7 were randomly selected. A sample of 378 farm household heads was randomly selected using the district census data as the sample frame. Krejcie and Morgan's (1970) statistical table for sample size selection led to the selection of 378 respondents from the household population of 23,863.

#### Data Sources and Collection Methods

The chapter used quantitative primary data. Data collection lasted for 6 months, starting from April to September 2018. Prior to data collection, the Institutional Review Committee of the Pan African University, Cameroon, approved the study. The data collection instrument was questionnaire survey. The questionnaire was divided into sections to collect data on the respondents' demographic characteristics, access to essential assets, and adaptation strategies.

#### Data Analysis

Primary data was analyzed using the Statistical Package for Social Sciences (SPSS) version 20. Data cleaning was performed through frequency analysis to identify the missing data. Preliminary analyses, such as outliers and normality tests, were

**Table 1** Variables description and coding

Variable description	Variable coding
<b>Dependent variable</b>	
Have you adapted to climate change?	Yes = 1 No = 0
<b>Independent variables</b>	
Sex	Male = 1 Female = 0
Age	Years (Number)
Household size	Number
Education	Yes = 1 No = 0
Marital status	Married = 1 Else = 0
Access to land	Yes = 1 No = 0
Access to extension	Yes = 1 No = 0
Access to market	Yes = 1 No = 0
Knowledge of climate change	Yes = 1 No = 0
Access to technology (e.g. phone)	Yes = 1 No = 0
Farming experience	Yes = 1 No = 0

Source: Fieldwork, 2018

conducted using box and scatter plots as well as line graphs (Pallant 2016). Two binary logistic regression models were specified for the analysis. The first binary logistic regression model explored factors that predicted the respondents' climate change adaptation strategies. The dependent variable in the first model was adaptation that was operationalized as whether or not a respondent has adapted to climate change using any of the strategies available to them. The independent variables comprised of categorical and continuous variables, such as age, sex, household size, farming experience, marital status, access to land, access to technology (phone), access to market, extension service, and knowledge of climate change. Table 1 presents the variable coding and description.

The use of the preliminary regression model without the predictor variables resulted in an overall percentage of 59.2% in terms of whether respondents have adapted or not, which served as a baseline for comparison with the regression model that included predictor variables (Pallant 2016). The Omnibus Tests of Model Coefficient, which determines the "goodness of fit" of the regression model resulted in a significance level of 0.006 ( $p < 0.05$ ). The Omnibus goodness of fit test also resulted in a chi-squared value of 26.193, with 11 degrees of freedom. In addition, the Hosmer–Lemeshow goodness-of-fit test resulted in a chi-squared value of 6.701

with 8 degrees of freedom and a significant value of 0.569. Pallant (2016) asserts that for the Hosmer–Lemeshow test to be significant, the significant value must exceed 0.05. The significant value of 0.569 exceeded 0.05, which is indicative of the goodness of fit of the model. The Cox and Snell R-squared and Nagelkerke R-squared indicated that the predictor variables account for 26.7% and 29.1% of variation in the dependent variable, respectively. In addition, the percentage accuracy in classification (PAC) table (Pallant 2016) resulted in an overall percentage of 62.3%, which exceeded the initial value of 59.2%. This chapter computed for the sensitivity of the model. According to Pallant (2016), the sensitivity of the model is defined as the percentage of the respondents who have or have not adapted to climate change, which has been accurately identified by the model. It is computed by dividing the number of cases predicted by the total number predicted and multiplied by 100 (Pallant 2016). The positive predictive (true positive) value indicates the percentage of respondents who have adapted to climate change and has been accurately identified by the model. The positive predictive value is 57.5%. Conversely, the negative predictive value (true negative) is the percentage of respondents who have not adapted and has been accurately identified by the model. The computation resulted in 61.8% for the negative predictive value.

In the second model, a binary logistic regression analysis was conducted to understand the adaptation strategies that effectively improve the respondents' food security and livelihood. The dependent variable was "whether or not adaptation strategies effectively enhance food security and livelihood of respondents." The independent variables consisted of categorical variables of 24 different adaptation strategies adopted by the respondents. In addition, the predictors of adaptation from the first model were included in the second model. Table 2 presents the coding and description of variables used in the second regression model.

The initial regression model without the predictor variables resulted in an overall percentage of 88.9% in terms of whether or not adaptation enhances food security and livelihood. The Omnibus Test of Model Coefficient resulted in a significance level of 0.018 ( $p < 0.05$ ), with a chi-squared value of 45.858 and 28 degrees of freedom. The Hosmer–Lemeshow goodness-of-fit test resulted in a chi-squared value of 7.085 with 8 degrees of freedom, at a significant value of 0.527. The Cox & Snell R-squared and Nagelkerke R-squared values were 0.114 and 0.227 respectively, indicating that the predictor variables account for 11.4% and 22.7% of the variation in the dependent variable, respectively.

The PAC table resulted in an overall percentage of 89.4%, exceeding the initial value of 88.9%. In addition, the chapter computed for the sensitivity of the model, which is the percentage of the respondents accurately identified by the model as those who indicated that adaptation enhances or does not enhance food security and livelihood. Sensitivity is computed by dividing the number of cases predicted by the total number predicted and multiplied by 100 (Pallant 2016). The positive predictive value (true positive) indicates the percentage of respondents who indicated that adaptation effectively enhances food security and livelihood. The positive predictive value was 89.8%. The negative predictive value (true negatives) is, however, the

**Table 2** Variables description and coding

<b>Variable description</b>	<b>Variable coding</b>
<b>Dependent variable</b>	
Does adaptation effectively enhance food security and livelihood?	Yes = 1 No = 0
<b>Independent variables</b>	
Migration	Yes = 1 No = 0
Fertilizer application	Yes = 1 No = 0
So Klin application	Yes = 1 No = 0
Education	Yes = 1 No = 0
Marital status	Married = 1 Else = 0
Delayed farming	Yes = 1 No = 0
Pesticides application	Yes = 1 No = 0
Cocoa pollination	Yes = 1 No = 0
Reduced number of diets	Yes = 1 No = 0
Reduced diet size	Yes = 1 No = 0
Change staple diet	Yes = 1 No = 0
Irrigation (hand/machine)	Yes = 1 No = 0
Extension services	Yes = 1 No = 0
Early maturing crops	Yes = 1 No = 0
Improved crops varieties	Yes = 1 No = 0
Livelihood diversification	Yes = 1 No = 0
Knowledge of climate change	Yes = 1 No = 0
Help from family and friends	Yes = 1 No = 0
Farming experience (years)	Yes = 1 No = 0
Crop diversification	Yes = 1 No = 0
Multiple cropping season	Yes = 1 No = 0
Weedicides application	Yes = 1 No = 0
Cocoa spraying	Yes = 1 No = 0
Farm expansion	Yes = 1

(continued)

**Table 2** (continued)

Variable description	Variable coding
Farm Based Organizations	No = 0 Yes = 1
Chicken droppings application	No = 0 Yes = 1
Drought resistant crops	No = 0 Yes = 1
Change in livestock	No = 0 Yes = 1

Source: Fieldwork, 2018

percentage of respondents who were accurately identified by the model to have indicated that adaptation does not enhance their food security and livelihood. The negative predictive value was 66.7%.

## Results and Discussion

### Adaptation Strategies Employed by Smallholder Farmers

The respondents in the study have adopted multiple adaptation strategies as presented in Table 3. The dominant adaptation strategy of the respondents is crop diversification, as reported by 93.4% of respondents. Antwi-Agyei et al. (2014a) similarly reported that majority of smallholder farmers in the Bongo District in the Upper East Region of Ghana practice crop diversification, as a response to climate change. Crop diversification is a traditional farming practice where multiple crops are planted on the same plot of land. The system enables farmers to harvest different crops throughout the year, thereby increasing food security. The practice may be influenced by the different maturity periods of crops, nutrient requirement, and demand on the market. Majority of the respondents have resorted to delay farming (70.1%), fertilizer application (68%), planting of early-maturing crops (42.1%), improved crop varieties (33.9%), and multiple-cropping season (51.3%). About 51.1% of the respondents reported of extension services. Studies have reported that extension services enable farmers to adapt to climate change through the transfer of knowledge and emerging farm practices (Boyaci and Yildiz 2016; Morrison and Sarris 2007).

Aside from extension services, the Government of Ghana's agricultural interventions, such as cocoa spraying and cocoa pollination, were also reported by 42.1% and 34.7% of the respondents, respectively, as adaptation strategies. It is interesting to note that some farmers are turning to the application of chicken dropping (17.5%) as an alternative to chemical fertilizer, which they hinted to be expensive. Unique to the findings of this chapter is the application of "So-Klin," a washing detergent used



**Table 3** Respondents' adaptation strategies

Indicators	(%)	N (378)
Migration	8.3	33
Fertilizer application	68.0	257
So Klin application	44.4	168
Planting of early-maturing crops	42.1	159
Improved crop varieties	33.9	128
Livelihood diversification	57.4	217
Help from family and friends	40.5	153
Crop diversification	93.4	353
Delayed farming	70.1	265
Multiple-cropping seasons	51.3	194
Pesticide application	34.7	131
Weedicide application	43.2	164
Cocoa pollination	34.7	131
Cocoa spraying	42.1	159
Reduced number of diets	57.4	217
Reduced meal size	66.4	251
Change in diets/staple food	52.4	198
Irrigation (hand/machine)	26.7	101
Extension services	51.1	193
Change in livestock	35.4	134
Planting of drought-resistant crops	18.3	69
Farm expansion	38.4	145
Joining in farm-based organizations	3.7	14
Chicken dropping application	17.5	66

Source: Fieldwork 2018

to control fall armyworm invasion. Some respondents indicated that they use both “So-Klin” and pesticides to control fall armyworms. It is reported that fall armyworms cause significant crop loss, particularly maize, sorghum, and millet (FAO 2018; Wild 2017). In Ghana, about 1.4 million ha of maize and cowpea have been destroyed by fall armyworms, whereas about 6400 ha of cocoa farms have been invaded (African Union 2017; Mpofu 2017; OCHA 2017). Loss of maize from fall armyworms in Africa has been estimated at US\$3 billion (African Union 2017). About 57.4% of the respondents have diversified their livelihood. Livelihood diversification has been reported in by Antwi-Agyei et al. (2014a, b) as a conduit to climate change adaptation. Table 3 demonstrates that the respondents have resorted to diet-related adaptation strategies as a response to climate change. For instance, respondents reported reduction in meal size (66.4%), change in diet/staple food (52.4%), and reduction in the number of diets (57.4%), which are consistent with the literature (Giannini et al. 2016; Quaye 2008). Other adaptation strategies include help from family and friends (40.5%), pesticide (34.7%) and weedicide (43.2%)

application, change in livestock (35.3%), farm expansion (38.4%), irrigation (26.7%), and planting of drought-resistant crops (18.3%).

## Predictors of Adaptation Strategies

The output of the binary logistic regression analysis is presented in Table 4. The beta ( $\beta$ ) values represent the change in the logit of the outcome variable (the log odds ratio) with a unit change in the predictor variable. The  $\beta$  value for years of farming experience, for instance, is  $-0.616$ , which indicates that an increase in the experience of a respondent by 1 year will result in a decrease in the adaptation of the respondents to climate change by 0.616. Put differently, the finding indicates that as the years of experience of a respondent increase, there is less likelihood that the respondent will not adapt to climate change. An increase in education increases climate change adaptation by 0.581, whereas access to market and marital status also increase adaptation by 0.178 and 0.583, respectively. Respondents with knowledge of climate change are more likely to adapt to climate change by 1.715. These findings are consistent with the literature (Osumanu et al. 2017; Tessema et al. 2018). For instance, as the level of education increases, farmers are likely to increase their climate change knowledge and become more concerned of the need to adapt. In addition, education increases farmers' knowledge of available and emerging adaptation strategies, including technology and climate-smart agriculture.

The Wald statistic with a chi-squared distribution demonstrates whether or not the  $\beta$  values for predictor variables are significantly different from zero (Mensah 2008). From Table 4, household size, for instance, has a Wald statistic of 2.171, which is significantly different from 0. However, the contribution of household size to the model is statistically insignificant at a  $p$ -value of 0.141 (thus,  $p < 0.05$ ). From the model, years of experience, education, marital status, and knowledge of climate

**Table 4** Binary logistic regression of the predictors of climate change adaptation

Variables	$\beta$	Wald	Significance	Exp( $\beta$ )
Sex	-0.112	0.176	0.675	0.894
Age	0.008	0.728	0.393	1.008
Household size	0.037	2.171	0.141	1.037
Experience	-0.616	3.752	0.050*	0.540
Education	0.581	4.738	0.030*	1.789
Marital status	0.583	4.085	0.043*	1.792
Access to land	-0.520	1.582	0.208	0.594
Access to technology	-0.443	1.712	0.191	0.642
Access to extension services	-0.028	0.012	0.914	0.973
Market	0.178	0.451	0.502	1.195
Climate change knowledge	1.715	4.739	0.029*	5.559
Constant	-2.310	5.263	0.022	0.099

Source: Computed from fieldwork 2018

change have Wald statistics of 3.752, 4.738, 4.085, and 4.739, respectively, which are statistically significant at  $p$ -values of 0.050, 0.030, 0.043, and 0.029, respectively. Marital status, for instance, plays a significant role in climate change adaptation, as it promotes pool of resources. In addition, married household heads are more likely to adapt due to their responsibility to feed their families and cater for their wards. Studies have revealed that the farming experience and knowledge of climate change significantly influence climate change adaptation (Osumanu et al. 2017; Tessema et al. 2018).

Another important statistic presented in Table 4 is the  $\text{Exp}(\beta)$ . These values, which are the odd ratios of the predictor variables, show the odds of the outcome variable occurring as a result of a unit change in the predictor variable. Statistically, the odd of an event is the probability of that event occurring divided by the inverse or the probability of that event not occurring (Mensah 2008).  $\text{Exp}(\beta)$  values greater than 1 means that an increase in the predictor variables results in an increase in the odds of the outcome variable, whereas  $\text{Exp}(\beta)$  values less than 1 show an inverse relationship between the odds of the outcome and the predictor variable. For instance, knowledge of climate change has  $\text{Exp}(\beta)$  value of 5.559, which indicates that there is a positive relationship between adaptation and knowledge of climate change. As such, it can be interpreted that increasing the knowledge of climate change of a respondent increases the respondent's adaptation to climate change. Table 4 demonstrates that age, household size, education, marital status, and market increase adaptation to climate change, whereas sex, experience, access to land, technology, and extension service reduce adaptation to climate change. It can be concluded from the model that years of experience, education, marital status, and knowledge of climate change are significant predictors of climate change adaptation, which is consistent with the previous studies (Osumanu et al. 2017; Tessema et al. 2018). The equation of the model can be written as  $\text{Logit}(\text{Adaptation}) = -2.310(\text{Constant}) - 0.112*\text{Sex} + 0.008*\text{Age} + 0.037*\text{Household size} - 0.616*\text{Experience} + 0.581*\text{Education} + 0.583*\text{Marital status} - 0.520*\text{Land} - 0.443*\text{Technology} - 0.028*\text{Extension} + 0.178*\text{Market} + 1.715*\text{Climate change knowledge}$ .

## Predictors of Effective Adaptation

Table 5 presents the output of the binary logistic regression estimation. The  $\beta$  value is the change in the logit of the outcome variable (the log odds ratio) as a result of a unit change in a the predictor variable. The  $\beta$  values indicate that improved crop varieties, weedicide application, and change in staple food consumption, for instance, increase food security and livelihood by 1.130, 1.315, and 1.333, respectively. It can be asserted that improved crop varieties, weedicide application, and change in staple food consumption have positive relationships with food security and livelihood. The more a respondent adopts these adaptation strategies, the more likely food security and livelihood of the respondent will improve. Other adaptation strategies, such as cocoa spraying, multiple-cropping season, and drought-resistant crops, are positively related to food security and livelihood as a unit increase in these strategies

**Table 5** Binary logistic regression of the predictors of effective adaptation

Variabiles	$\beta$	Wald	Significance	Exp( $\beta$ )
Migration	0.305	0.121	0.728	1.357
Fertilizer application	0.016	0.001	0.973	1.016
So Klin application	0.418	0.586	0.451	1.519
Planting of early-maturing crops	-1.325	3.918	0.048*	0.266
Improved crop varieties	1.130	2.374	0.123	3.095
Livelihood diversification	-0.705	2.212	0.145	0.494
Help from family and friends	0.221	0.193	0.660	1.248
Crop diversification	0.246	0.077	0.782	1.279
Delayed farming	-0.655	1.664	0.197	0.520
Multiple-cropping season	0.531	0.922	0.337	1.701
Pesticide application	-1.117	2.138	0.144	0.327
Weedicide application	1.315	3.444	0.500*	3.724
Cocoa pollination	0.200	0.068	0.795	1.222
Cocoa spraying	0.474	0.504	0.478	1.607
Reduced number of diets	-1.156	3.432	0.064	0.315
Reduce meal size	-0.357	0.292	0.589	0.700
Change in staple food consumption	1.333	7.111	0.008*	3.793
Irrigation	-0.308	0.238	0.626	0.735
Extension services	0.176	0.160	0.689	1.192
Change in livestock	-0.843	2.735	0.098	0.430
Planting of drought-resistant crops	0.884	1.429	0.232	2.420
Farm expansion	-0.008	0.000	0.987	0.992
Joining in farm-based organization	-1.145	1.506	0.220	0.318
Chicken dropping application	-0.822	3.465	0.063	0.440
Years of farming experience	0.154	0.100	0.752	1.166
Education	-0.365	0.692	0.405	0.694
Marital status	0.749	3.582	0.503*	2.116
Knowledge of climate change	-18.547	0.901	0.998	0.001
Constant	20.933	2.385	0.998	1.681

Source: Computed from fieldwork 2018

improves food security and livelihood by a margin of 0.474, 0.531, and 0.884, respectively. Among the predictors of adaptation, years of farming experience (0.154) and marital status (0.749) have a positive relationship with food security and livelihood.

The Wald statistic demonstrates whether or not the  $\beta$  values for predictor variables are significantly different from zero (Mensah 2008). Predictor variables such as marital status, chicken dropping application, planting of early-maturing crops, livelihood diversification, pesticide application, weedicide application, reduction in the number of diets, and change in staple food consumption, for instance, are significantly different from zero with Wald statistics of 3.582, 3.465, 3.918, 2.212, 2.138, 3.444, 3.432, and 7.111, respectively. The significance column in the table

presents the level of significance of the predictor variables in predicting effective adaptation. The model indicates that effective adaptation is significantly predicted by planting early-maturing crops (0.048), weedicide application (0.050), change in staple food consumption (0.008), and marital status (0.053). The  $\text{Exp}(\beta)$  values are the odds of the outcome variable occurring as a result of a unit change in the predictor variable. Statistically, the odd of an event is the probability of the event occurring divided by the inverse or the probability of that event not occurring (Mensah 2008).  $\text{Exp}(\beta)$  values greater than 1 indicate that an increase in the predictor variables result in an increase in the odds of the outcome variable, whereas  $\text{Exp}(\beta)$  values less than 1 show an inverse relationship between the odds of the outcome and the predictor variable.

For instance, planting of drought-resistance crops, change in staple food consumption, weedicide application, and improved crop varieties have  $\text{Exp}(\beta)$  values greater than 1 which indicates a positive correlation between effective adaptation (food security and livelihood) and these predictors. Marital status (0.001), planting of early-maturing crops, (0.266), and pesticide application (0.372), for instance, have  $\text{Exp}(\beta)$  values less than 1 which indicates an inverse or negative relationship with effective adaptation (food security and livelihood). It can be summed up from the model that planting of early-maturing crops, weedicide application, change in staple crop consumption, and marital status significantly predict effective adaptation (food security and livelihood). The equation of the model can be written as  $\text{Logit}(\text{EffectiveAdaptation}) = 20.933(\text{Constant}) + 0.035*\text{Migration} + 0.016*\text{Fertilizer application} + 0.418*\text{So Klin application} - 1.325*\text{Planting of early-maturing crops} + 1.130*\text{Improved crop varieties} - 0.705*\text{Livelihood diversification} + 0.221*\text{Help from family and friends} + 0.246*\text{Crop diversification} - 0.655*\text{Delayed farming} + 0.531*\text{Multiple-cropping season} - 1.117*\text{Pesticide application} + 1.315*\text{Weedicide application} + 0.2008*\text{Cocoa pollination} + 0.474*\text{Cocoa spraying} - 1.156*\text{Reduced number of diets} - 0.357*\text{Reduced meal size} + 1.333*\text{Change in staple food} - 0.308*\text{Irrigation} + 0.176*\text{Extension} - 0.843*\text{Change in livestock} + 0.884*\text{Planting of drought-resistant crops} - 0.008*\text{Farm expansion} - 1.145*\text{Joining in farm-based organization} - 0.822*\text{Chicken dropping application} + 0.154*\text{Experience} - 0.365*\text{Education} + 0.749*\text{Marital status} - 18.547*\text{Climate change knowledge}$ .

---

## Conclusion and Recommendations

Ghana's ability to promote food security, livelihood, and rural and pro-poor economic development is largely dependent on agriculture and hence smallholder farmers who constitute the bulk of the labor force in Ghana and contribute about 80% of the food produced. The agriculture sector, in particular, and smallholder farmers, in general, are vulnerable to climate change, due to subsistence and climate-dependent nature of agriculture and low adaptive capacity of smallholder farmers, in addition to high poverty and less access to essential assets. Nevertheless, smallholder farmers in Ghana are adapting to climate change through multiple self-induced and

externally supported adaptation strategies. This chapter, which sought to explore smallholder farmers' adaptation and examine the predictors of adaptation and effective adaptation, found that smallholder farmers in the rural Adansi North District of Ghana use multiple on-/off-farm and diet-based adaptation strategies to respond to climate change. The chapter also found that marital status, years of farming experience, education, and knowledge of climate change significantly influence adaptation, whereas marital status, weedicide application, change in diet/staple food, and planting of early-maturing crops significantly enhance effective adaptation (food security and livelihood) of smallholder farmers.

While farmers are adapting to climate change, most adaptation strategies of smallholder farmers do not necessarily enhance their food security and livelihood, which may be due to the resource-constrained environment and low adaptive capacity. As such, it is imperative that social intervention programs and policies that promote resource distribution and access must be strengthened, particularly in rural communities, to increase smallholder farmers' access to essential socioeconomic assets, thereby increasing adaptive capacity, improving adaptation strategies, and reducing climate change impacts. In addition, mass education of farmers on climate change must be intensified to improve climate change knowledge/perception, reduce misconceptions associated with climate change, and ensure effective adaptation, as farmers' climate change perception strongly influences climate change adaptation. Farm-based organizations can play a significant role in climate change education and must be promoted particularly in rural communities. Moreover, local institutions, particularly those that provide extension and advisory services, must be intensified and resourced with technology, personnel, and infrastructure to provide services that enable farmers to adapt effectively to climate change through skills and knowledge transfer.

While this chapter limited its geographic scope to only the Adansi North District, the chapter could do better if it covered a wider geographic scope across different ecological zones in Ghana, to deepen the understanding of how different communities are adapting to climate change, which is very important for fit-for-purpose climate change policies. Hence, further studies must consider larger population with a wider geographic location to better understand climate change adaptation in Ghana. In addition, a combination of quantitative and qualitative data on climate change adaptation can greatly improve an understanding of climate change and advance the debate on adaptation. This chapter used only quantitative data, but future studies must go further to include qualitative lived experiences of smallholder farmers. Nevertheless, the chapter has made significant contributions to climate change discourse and has provided insights, with the potential to shape climate change policies in Ghana, in particular, and Africa, in general.

**Acknowledgments** The authors are grateful to the African Union for funding this study through the Pan African University PhD research grant awarded to the first author.

## References

- Adu DT, Kuwornu JKM, Anim-Somuah H, Sasaki N (2018) Application of livelihood vulnerability index in assessing smallholder maize farming households' vulnerability to climate change in Brong-Ahafo region of Ghana. *Kasetsart J Soc Sci* 39(1):22–32. <https://doi.org/10.1016/j.kjss.2017.06.009>
- African Union (2017) Phytosanitary news bulletin: fall armyworms storm Africa. African Union, Yaounde
- AGRA (2014) Africa agriculture status report 2014: climate change and smallholder agriculture in sub-Saharan Africa. AGRA, Nairobi. Retrieved from [www.agra.org](http://www.agra.org)
- Antwi-Agyei P, Dougill AJ, Stringer LC (2014a) Barriers to climate change adaptation: evidence from northeast Ghana in the context of a systematic literature review. *Clim Dev* 7:297–309. <https://doi.org/10.1080/17565529.2014.951013>
- Antwi-Agyei P, Stringer LC, Dougill AJ (2014b) Livelihood adaptations to climate variability: insights from farming households in Ghana. *Reg Environ Chang* 14(4):1615–1626. <https://doi.org/10.1007/s10113-014-0597-9>
- Boyaci M, Yildiz O (2016) An overview of agricultural extension services in Turkey. *Bulgarian J Agr Sci* 22(1):151–157
- Bryant C, Smit B, Brklacich M, Johnston T, Smithers J, Chiotti Q, Singh B (2000) Adaptation in Canadian agriculture to climatic variability and change. *Clim Chang* 45:181–201
- Connolly-Boutin L, Smit B (2016) Climate change, food security, and livelihoods in sub-Saharan Africa. *Reg Environ Chang* 16:385–399. <https://doi.org/10.1007/s10113-015-0761-x>
- Dankelman I (2010) Gender and climate change: an introduction. Routledge, London
- EEA (2013) Adaptation in Europe: addressing risks and opportunities from climate change in the context of socioeconomic developments. EEA, Copenhagen. Retrieved from <http://www.eea.europa.eu/publications/adaptation-in-europe>
- FAO (2018) Briefing note on FAO actions on fall armyworm in Africa. FAO, Rome. Retrieved from <http://www.fao.org/3/BS183E/bs183e.pdf>
- Fosu-Mensah BY, Vlek PL, MacCarthy D (2012) Farmers' perception and adaptation to climate change: a case study of Sekyedumase district in Ghana. *Environ Sustain Dev* 8(3):1–13. <https://doi.org/10.1007/s10668-012-9339-7>
- Giannini A, Krishnamurthy PK, Cousin R, Labidi N, Choularton RJ (2016) Climate risk and food security in Mali : a historical perspective on adaptation. *Earth's Future* 5:144–157. <https://doi.org/10.1002/ef2.176>
- GIZ (2014) The vulnerability sourcebook: concepts and guidelines for standardized vulnerability assessment. GIZ, Eschborn
- GSS (2010) Population and housing census 2010. GSS, Accra
- GSS (2014) 2010 population and housing census: district analytical report, Adansi North District. GSS, Accra
- Gyampoh BA, Amisah S, Idinoba M, Nkem JN (2009) Using traditional knowledge to cope with climate change in rural Ghana. *Unasyuva* 60(231/232):70–74. <https://doi.org/10.1016/j.foodchem.2011.01.039>
- Hirons M, Boyd E, McDermott C, Asare R, Morel A, Mason J, . . . Norris K (2018) Understanding climate resilience in Ghanaian cocoa communities – advancing a biocultural perspective. *J Rural Stud* 63(August):120–129. <https://doi.org/10.1016/j.jrurstud.2018.08.010>
- IPCC (2007) Climate change 2007: impacts, adaptation and vulnerability. Contribution of working group II to the fourth assessment report of the intergovernmental panel on climate change. Cambridge University Press, Cambridge, MA
- IPCC (2014) Climate change 2014: synthesis report. Contributions of working groups I, II and III to the fifth assessment report of the intergovernmental panel on climate change. IPCC, Geneva

- IPCC (2018) IPCC special report on the impacts of global warming of 1.5 °C – summary for policy makers. IPCC, Incheon. Retrieved from <http://www.ipcc.ch/report/sr15/>
- Krejcie RV, Morgan DW (1970) Determining sample size for research activities. *Educ Psychol Meas* 30:607–610. <https://doi.org/10.1177/001316447003000308>
- Lopez-Ridaura S, Frelat R, van Wijk MT, Valbuena D, Krupnik TJ, Jat ML (2018) Climate smart agriculture, farm household typologies and food security: an ex-ante assessment from Eastern India. *Agric Syst* 159:57–68. <https://doi.org/10.1016/j.agsy.2017.09.007>
- Mensah J (2008) Religious transnationalism among Ghanaian immigrants in Toronto: a binary logistic regression analysis. *Can Geogr* 52(3):309–330. <https://doi.org/10.1111/j.1541-0064.2008.00215.x>
- Morrison J, Sarris A (2007) WTO rules for agriculture. FAO, Rome
- Mpofu V (2017) The foreign invader costing African farmers \$3 billion. Retrieved September 15, 2017, from [http://www.irinnews.org/news/2017/09/14/foreign-invader-costing-african-farmers-3-billion?utm\\_source=IRIN+-+the+inside+story+on+emergencies&utm\\_campaign=860dc2c80d-RSS\\_EMAIL\\_CAMPAIGN\\_ENGLISH\\_AFRICA&utm\\_medium=email&utm\\_term=0\\_d842d98289-860dc2c80d-7546666](http://www.irinnews.org/news/2017/09/14/foreign-invader-costing-african-farmers-3-billion?utm_source=IRIN+-+the+inside+story+on+emergencies&utm_campaign=860dc2c80d-RSS_EMAIL_CAMPAIGN_ENGLISH_AFRICA&utm_medium=email&utm_term=0_d842d98289-860dc2c80d-7546666)
- OCHA (2017) West and Central Africa: weekly regional humanitarian snapshot. New York. Retrieved from <https://reliefweb.int/sites/reliefweb.int/files/resources/ExternalWeekly24-30October2017.pdf>
- Osumanu IK, Aniah P, Yelfaanibe A (2017) Determinants of adaptive capacity to climate change among smallholder rural households in the Bongo District, Ghana. *Ghana J Dev Stud* 14 (2):142–163. <https://doi.org/10.4314/gjds.v14i2.8>
- Pallant J (2016) SPSS survival manual – a step by step guide to data analysis using SPSS program, 6th edn. McGraw-Hill, London
- Pearce LBT, Ford JD (2015) Systematic review approaches for climate change adaptation research. *Reg Environ Chang* 15:755–769. <https://doi.org/10.1007/s10113-014-0708-7>
- Quaye W (2008) Food security situation in northern Ghana, coping strategies and related constraints. *J Agric Res* 3(5):334–342. <https://doi.org/10.1126/science.1185383>
- Sarpong DB, Anyidoho NA (2012) Climate change and agricultural policy processes in Ghana (Working paper 045). Future Agricultures, Accra
- Smit B, Skinner M (2002) Adaptation options in agriculture to climate change: a typology. *Mitig Adapt Strateg Glob Chang* 7:85–114
- Smit B, Burton I, Klein RJ, Wandel J (2000) An anatomy of adaptation to climate change and variability. *Climate Change* 45:223–251
- Tessema YA, Joerin J, Patt A (2018) Factors affecting smallholder farmers' adaptation to climate change through non-technological adjustments. *Environ Dev* 25:33–42. <https://doi.org/10.1016/j.envdev.2017.11.001>
- Turner RB, Kasperson RE, Matson PA, McCarthy JJ, Corell RW, Christensen L, . . . Schiller A (2003) A framework for vulnerability analysis in sustainability science. *Natl Acad Sci* 100 (14):8074–8079. <https://doi.org/10.11764/j.issn.1672-1926.2014.S1.0091>
- Wild S (2017) Invasive pest hits Africa. *Nature* 509:13–14. <https://doi.org/10.1038/509015a>
- World Bank (2018) 2025 targets to step up climate action. World Bank, Washington, DC. Retrieved from <http://pubdocs.worldbank.org/en/368601543772742074/2025-Targets-to-Step-Up-Climate-Action.pdf>
- World Bank (2018b) Adaptation and resilience: action plan. World Bank, Washington, DC. Retrieved from [www.worldbank.org/climatechange](http://www.worldbank.org/climatechange)
- Yaro JA (2013a) Building resilience and reducing vulnerability to climate change: implications for food security in Ghana. Friedrich Ebert Stiftung, Accra
- Yaro JA (2013b) The perception of and adaptation to climate variability/change in Ghana by small-scale and commercial farmers. *Reg Environ Chang* 13(6):1259. <https://doi.org/10.1007/s10113-013-0443-5>
- Yaro JA, Teye J, Bawakyillenuo S (2014) Local institutions and adaptive capacity to climate change/variability in the northern savannah of Ghana. *Clim Dev* 7(3):37–41. <https://doi.org/10.1080/17565529.2014.951018>



**Open Access** This chapter is licensed under the terms of the Creative Commons Attribution 4.0 International License (<http://creativecommons.org/licenses/by/4.0/>), which permits use, sharing, adaptation, distribution and reproduction in any medium or format, as long as you give appropriate credit to the original author(s) and the source, provide a link to the Creative Commons license and indicate if changes were made.

The images or other third party material in this chapter are included in the chapter's Creative Commons license, unless indicated otherwise in a credit line to the material. If material is not included in the chapter's Creative Commons license and your intended use is not permitted by statutory regulation or exceeds the permitted use, you will need to obtain permission directly from the copyright holder.





# Biomass Burning Effects on the Climate over Southern West Africa During the Summer Monsoon

# 73

Alima Dajuma, Siélé Silué, Kehinde O. Ogunjobi, Heike Vogel, Evelyne Touré N'Datchoh, Véronique Yoboué, Arona Diedhiou, and Bernhard Vogel

## Contents

Introduction .....	1518
Description of the Study Area and Methodology .....	1520
Study Area .....	1520
Methods .....	1521
Results and Discussion .....	1523
Impact on Meteorology .....	1523
Impact on the Atmospheric Composition .....	1524
Adaptation and Mitigation Strategies .....	1528
Conclusions .....	1529
References .....	1530

This chapter was previously published non-open access with exclusive rights reserved by the Publisher. It has been changed retrospectively to open access under a CC BY 4.0 license and the copyright holder is “The Author(s)”. For further details, please see the license information at the end of the chapter.

A. Dajuma (✉)

Department of Meteorology and Climate Sciences, West African Science Service Centre on Climate Change and Adapted Land Use (WASCAL), Federal University of Technology Akure (FUTA), Ondo State, Nigeria

Laboratoire de Physique de l’Atmosphère et de Mécaniques des Fluides (LAPA-MF),  
Université Félix Houphouët-Boigny, Abidjan, Côte d’Ivoire  
e-mail: [alima.dajuma@yahoo.com](mailto:alima.dajuma@yahoo.com)

S. Silué

Université Peleforo Gon Coulibaly, Korhogo, Côte d’Ivoire  
e-mail: [sielesil@yahoo.fr](mailto:sielesil@yahoo.fr)

**Abstract**

Biomass Burning (BB) aerosol has attracted considerable attention due to its detrimental effects on climate through its radiative properties. In Africa, fire patterns are anticorrelated with the southward-northward movement of the inter-tropical convergence zone (ITCZ). Each year between June and September, BB occurs in the southern hemisphere of Africa, and aerosols are carried westward by the African Easterly Jet (AEJ) and advected at an altitude of between 2 and 4 km. Observations made during a field campaign of Dynamics-Aerosol-Chemistry-Cloud Interactions in West Africa (DACCIWA) (Knippertz et al., Bull Am Meteorol Soc 96:1451–1460, 2015) during the West African Monsoon (WAM) of June–July 2016 have revealed large quantities of BB aerosols in the Planetary Boundary Layer (PBL) over southern West Africa (SWA).

This chapter examines the effects of the long-range transport of BB aerosols on the climate over SWA by means of a modeling study, and proposes several adaptation and mitigation strategies for policy makers regarding this phenomenon. A high-resolution regional climate model, known as the Consortium for Small-scale Modelling – Aerosols and Reactive Traces (COSMO-ART) gases, was used to conduct two set of experiments, with and without BB emissions, to quantify their impacts on the SWA atmosphere. Results revealed a reduction in surface shortwave (SW) radiation of up to about  $6.5 \text{ W m}^{-2}$  and an 11% increase of Cloud Droplets Number Concentration (CDNC) over the SWA domain. Also, an increase of 12.45% in Particulate Matter ( $\text{PM}_{2.5}$ ) surface concentration was observed in Abidjan ( $9.75 \mu\text{g m}^{-3}$ ), Accra ( $10.7 \mu\text{g m}^{-3}$ ), Cotonou ( $10.7 \mu\text{g m}^{-3}$ ), and Lagos ( $8 \mu\text{g m}^{-3}$ ), while the carbon monoxide (CO) mixing ratio increased by 90 ppb in Abidjan and Accra due to BB. Moreover, BB aerosols were found to contribute to a

---

K. O. Ogunjobi

Department of Meteorology and Climate Sciences, West African Science Service Centre on Climate Change and Adapted Land Use (WASCAL), Federal University of Technology Akure (FUTA), Ondo State, Nigeria

Federal University of Technology Akure (FUTA), Ondo State, Nigeria

e-mail: [kenog2010@gmail.com](mailto:kenog2010@gmail.com)

H. Vogel · B. Vogel

Institute of Meteorology and Climate Research, Karlsruhe Institute of Technology (KIT), Karlsruhe, Germany

e-mail: [heike.vogel@kit.edu](mailto:heike.vogel@kit.edu); [bernhard.vogel@kit.edu](mailto:bernhard.vogel@kit.edu)

E. T. N'Datchoh · V. Yoboue

Laboratoire de Physique de l'Atmosphère et de Mécaniques des Fluides (LAPA-MF), Université Félix Houphouët-Boigny, Abidjan, Côte d'Ivoire

e-mail: [ndatchoheve@yahoo.fr](mailto:ndatchoheve@yahoo.fr); [yobouev@hotmail.com](mailto:yobouev@hotmail.com)

A. Diedhiou

Laboratoire de Physique de l'Atmosphère et de Mécaniques des Fluides (LAPA-MF), Université Félix Houphouët-Boigny, Abidjan, Côte d'Ivoire

Université Grenoble Alpes, IRD, Grenoble INP, IGE, Grenoble, France

e-mail: [arona.diedhiou@gmail.com](mailto:arona.diedhiou@gmail.com)

70% increase of organic carbon (OC) below 1 km in the PBL, followed by black carbon (BC) with 24.5%. This work highlights the contribution of the long-range transport of BB pollutants to pollution levels in SWA and their effects on the climate. It focuses on a case study of 3 days (5–7 July 2016). However, more research on a longer time period is necessary to inform decision making properly.

This study emphasizes the need to implement a long-term air quality monitoring system in SWA as a method of climate change mitigation and adaptation.

---

### Keywords

Adaptation strategy · Biomass burning · lowland · Southern West Africa · Modeling

---

### List of Abbreviations

ADF	Abidjan domestic fire
AEJ	African easterly jet
AGL	Altitude above ground level
AOD	Aerosol optical depth
BB	Biomass burning
BC	Black carbon
CDNC	Cloud droplets number concentration
CO	Carbon monoxide
COSMO-ART	Consortium for Small-scale Modelling – Aerosols and Reactive Traces gases
DACCIWA	Dynamics-Aerosol-Chemistry-Cloud Interactions in West Africa
DMS	Dimethyl sulfide
DWD	German weather service
EDGAR HTAP_v2	Emission Database for Global Atmospheric Research Hemispheric Transport of Air Pollution version 2
FRP	Fire radiative power
GFAS	Global Fire Assimilation System
ICON	Icosahedral nonhydrostatic
ITCZ	Intertropical convergence zone
ITD	Intertropical discontinuity
MODIS	Moderate Resolution Imaging Spectroradiometer
MOZART	Model for Ozone and Related Chemical Tracers
NO <sub>x</sub>	Nitrogen oxide
OC	Organic carbon
PBL	Planetary boundary layer
PM	Particulate matter
STRATOZ	Stratospheric ozone experiment
SW	Shortwave
SWA	Southern West Africa
TOA	Top of atmosphere

---

TROPOZ	Tropospheric ozone experiment
WAM	West African monsoon
WHO	World Health Organisation
WRF-Chem	Weather Research and Forecasting model coupled with Chemistry

---

## Introduction

Biomass Burning (BB) is one of the major sources of aerosols in Africa after Saharan dust. In the form of submicron accumulation mode BB pollutants are mainly composed of organic carbon (OC) and black carbon (BC) aerosols and carbon monoxide (CO), hydrocarbon, and nitrogen oxide (NO<sub>x</sub>), as gaseous pollutants. During the previous decades, an increasing number of studies have investigated the impacts of BB aerosols on radiation, weather, and climate. In general, the African fire pattern is strongly associated with the southward movement of the intertropical convergence zone (ITCZ) (N'Datchoh et al. 2015; Swap et al. 2002). BB occurs as a result of anthropogenic activities, such as land management, livestock grazing, and crop production (Bowman et al. 2011; Stowe et al. 2002; Mbow et al. 2000). BB is an important source of aerosols and trace gases in the atmosphere, with an estimated burned biomass of 3260–10,450 Tg a<sup>-1</sup> for tropical areas (Barbosa et al. 1999). Hao and Liu (1994) estimated that there was an amount of 2500 Tg a<sup>-1</sup> (46% of the tropics in total) over the tropical regions of Africa, to which the savanna contributes up to 1600 Tg a<sup>-1</sup> (30% of the total amount over the tropics).

BB affects the radiative energy budget of the Earth by absorbing and scattering solar radiation and modifies the properties of clouds as they serve as cloud condensation nuclei (CCN) or ice nuclei (IN). The global mean direct radiative effect of BC and OC from BB was quantified as being 0.155 W m<sup>-2</sup> for their overall effect, with 0.25 W m<sup>-2</sup> for BC (absorption) and -0.005 to +0.4 W m<sup>-2</sup> for OC (Jiang et al. 2016). BC traps a significant part of solar radiation in the atmosphere, thus reducing the surface incoming radiation as well as low surface sensible and latent heat fluxes (Huang et al. 2016). A modeling study by Walter et al. (2016) investigated the impact of the Canadian forest fires that occurred in July 2010 on SW radiation and temperature using the regional climate model, Consortium for Small-scale Modeling – Aerosols and Reactive Traces gases (COSMO-ART). Downwelling surface SW radiation was found to be reduced by up to 50% below the biomass plume under cloudless conditions due to absorption in dense smoke layers, furthermore leading to a decrease of up to 6 K of 2-m temperature. Surface cooling, as well as a warming in elevated layers, led to an increase in atmospheric stability, which induce a decrease of precipitation.

Thornhill et al. (2018) analyzed 30-year simulation to assess the impact of BB on the regional climate of South America. The simulations found a decrease in the downwelling clear-sky and all-sky SW radiation at the surface by 13.77 W m<sup>-2</sup> and 7.37 W m<sup>-2</sup>, respectively. Mean surface temperature was reduced by 0.14 ± 0.24 °C and a mean precipitation decrease of 14.5% was found in the peak region of BB. The authors found that, if BB increases during a particular dry season, the resulting

decrease in precipitation may in fact exacerbate drought. Pani et al. (2016) estimated the direct aerosol radiative effects of BB aerosols over northern Indochina from observed ground measurements of the optical properties of such aerosols. They found that the overall mean aerosol radiative forcing was  $-8 \text{ W m}^{-2}$  and  $-31.4 \text{ W m}^{-2}$  at TOA and at the surface, respectively.

Similarly, Huang et al. (2013) investigated the impact of direct radiative forcing of BC on West African Monsoon (WAM) precipitation during the dry season, and concluded that there was a reduction in precipitation in the WAM region due to the radiative effect of BC. They demonstrated that aerosols from the southern African hemisphere significantly reduced convective precipitation, particularly during the boreal cold season, when BB smoke was prevalent. They also highlighted that BB can affect local weather and climate over West Africa. These results suggest that reductions in cloud amount, cloud top height, and surface precipitation are due to a high BC aerosols load in the atmosphere.

During the airborne measurement campaigns of the Stratospheric Ozone Experiment (STRATOZ) of March 1985 and the Tropospheric Ozone Experiment (TROPOZ) of December 1987, Marengo et al. (1990) discovered that large CO concentrations are present over the mid-Atlantic Ocean as well over West Africa, which is evidence of the lofting of BB from Central and Southern Africa. The plumes arising from agricultural burning fumes mix in a 3–4 km deep boundary layer over Africa as a result of convergence, before overriding moister and cooler air and being advected westward over the Atlantic Ocean (Chatfield et al. 1998). In another study, it was shown that BB plumes from Central and Southern Africa are transported each year during the WAM season and carried westward by a jet located at 700 hPa between 2 and 4 km altitude (Barbosa et al. 1999; Mari et al. 2008). In addition, Real et al. (2010) found ozone plumes in the mid- and upper troposphere over the Gulf of Guinea as a result of the long-range transport of BB from Central Africa. Using backward trajectories, Mari et al. (2008) demonstrated that the intrusion of BB into the upper troposphere of the Gulf of Guinea and the northern hemisphere was controlled by the active and break phases of the southern hemisphere's African Easterly Jet (AEJ) during the summer monsoon (July–August 2006).

The number and size distributions of BB aerosols in southern West Africa (SWA) are dominated by the accumulation mode (Haslett et al. 2019). Likewise, according to a modeling study by Menut et al. (2018), BB from Central and Southern Africa has increased the level of air pollution in urban cities, such as Lagos and Abidjan (approximately  $150 \mu\text{g m}^{-3}$  for CO,  $10\text{--}20 \mu\text{g m}^{-3}$  for O<sub>3</sub>, and  $5 \mu\text{g m}^{-3}$  for PM<sub>2.5</sub>). The contribution of BB in PM<sub>2.5</sub> concentrations from Central Africa increased from ~10% in May to ~52% in July (Deroubaix et al. 2018). Haslett et al. (2019) found a significant aerosol mass concentration in the SWA boundary layer, both over the ocean and over the continental background, with similar chemical properties. They suggested that the upstream (Gulf of Guinea) aerosols originated from Central African BB, and demonstrated that these aerosols affected cloud optical properties but were less sensitive to precipitation.

Although there have been studies, like the above, on the distribution and impact of BB in various regions the impact of BB aerosols from Central and Southern Africa

on the meteorology and climate over SWA specifically has not yet been fully investigated.

Research during these past decades has shown that BB aerosols injected into the atmosphere have adverse effects on radiation and climate. Remote pollution from the long-range transport of BB appears to affect the levels of atmospheric aerosol pollution over SWA during the summer monsoon. It originates from Central and Southern Africa as a result of agricultural activities, land management, livestock grazing, and crop production. It is carried westward by the African Easterly Jet (AEJ) toward the tropical Atlantic Ocean, the Gulf of Guinea, and SWA, aloft at the mid-level troposphere (2–4 km). Recently, an intensive field campaign within the framework of Dynamics-Aerosol-Chemistry-Cloud Interactions in West Africa (DACCIWA) in SWA, observed large amounts of the BB as background concentration in the Planetary Boundary Layer (PBL), dominated by OC (Haslett et al. 2019).

In this chapter, then, the changes in atmospheric variables (precipitation, clouds, solar radiation) due to BB aerosols are examined. During a case study of 3 days (5–7 July 2016), two sets of simulations are performed: with and without BB. The differences make it possible to quantify the impacts of BB on the state of the atmosphere. The following research questions are addressed in this work:

- What is the relative contribution of BB aerosols to the atmospheric composition of the SWA region?
- What is the effect of BB on the climate of SWA?
- What are the practical behaviors and actions to be taken in order to reduce the level of pollution over SWA?

---

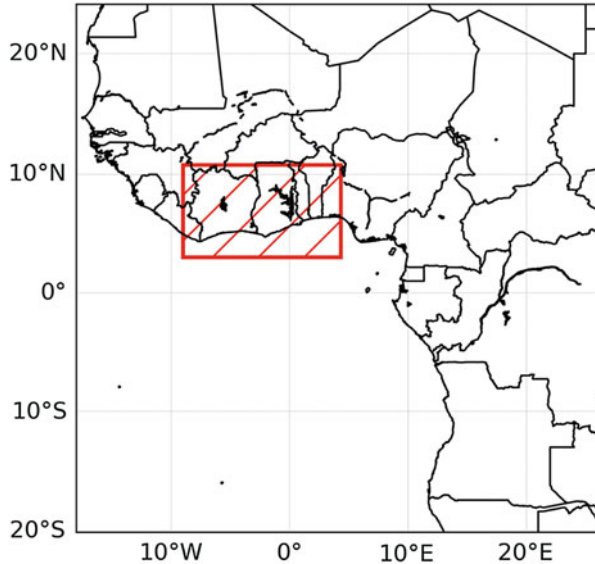
## Description of the Study Area and Methodology

This section describes the study area, where the data was obtained (section “[Study Area](#)”), and the methodology used (section “[Methods](#)”) to obtain the results.

### Study Area

The study domains comprise an outer domain, that is, D1: West Africa, and a nested domain, that is, D2: southern West Africa (SWA), spreading from 3°N to 10°N and 9°W to 4°E (Fig. 1). The latitudinal extent of D1 (18°W–26.6°E; 20°S–24.6°N) covers the Sahel region, as well as the eastern Atlantic Ocean and Central Africa. The wide spatial coverage of D1 allows us to account for the long-range transport of aerosols, such as dust aerosol from the Sahel and the Sahara Desert and BB from Central Africa. The nested domain D2 (9°W–4°E; 3°–10.8°N), located in SWA, is characterized by tropical forest in the South and grassland and savanna in the North. The climate is that of typical tropics zones governed by the North-South shift of the Intertropical Convergence Zone (ITCZ) or the Intertropical discontinuity (ITD) (over the land), which determines the rainy/dry seasons. During the period under

**Fig. 1** Model domains D1 (outer domain) and D2 (nested domain) hacked in red. The horizontal resolution in case of D1 is 5 km and in case of D2 is 2.5 km



investigation (July 2016), the WAM was prevalent in the study domain. The WAM is generated by the temperature gradient between the Atlantic Ocean, which is cool (monsoon), and the north (the Sahara Desert), which is warm.

## Methods

This section describes the model setup (section “[Model Setup](#)”) and the biomass burning experiment (section “[Biomass Burning Experiment](#)”).

### Model Setup

Simulations were performed with the regional scale model COSMO-ART (Vogel et al. 2009) at a spatial resolution of 5 km for D1 and nested to 2.5 km for D2 with 50 and 80 levels up to 30 km altitude above ground level (AGL), respectively. Simulations were run for 9 days over D1 (29 June–7 July 2016), and 3 days (5–7 July 2016) were analyzed over D2 as a case study for detailed investigation. COSMO-ART allows for the treatment of the aerosol dynamics, atmospheric chemistry, feedback with radiation, and cloud microphysics (Athanasopoulou et al. 2013; Bangert et al. 2012; Knote et al. 2010; Vogel et al. 2009). A gas flaring emission parameterization of the area of interest in SWA has been developed by Deetz and Vogel (2017), using a combination of remote sensing observations and physically based combustion equations to better reproduce the atmospheric chemistry of the area of interest. The implementation of a 1 D-plume rise model of BB aerosols and gases into COSMO-ART was realized by Walter et al. (2016), which calculates

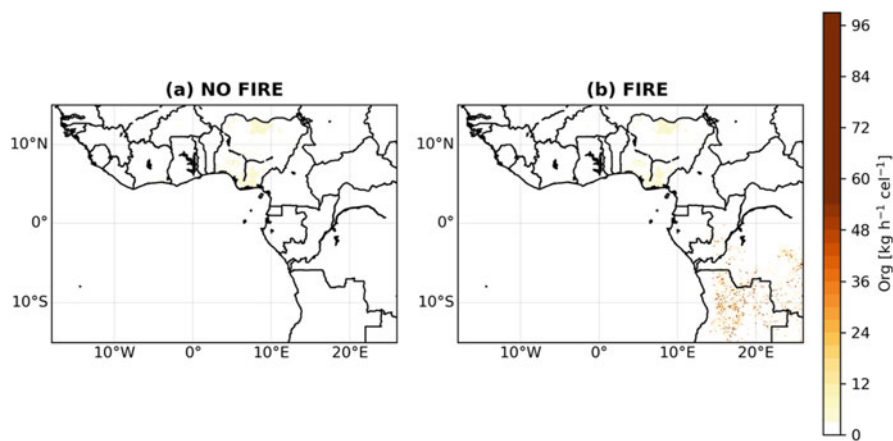


online the injection height (top and bottom limit) of the BB plume. For this study, several emission datasets from different sources have been used. The BB emissions data were obtained from the Global Fire Assimilation System (GFAS) version 1.2 (Kaiser et al. 2012). It is a satellite retrieved dataset of daily fire radiative power (FRP) measurements from the Moderate Resolution Imaging Spectroradiometer (MODIS) Terra and Aqua. Anthropogenic emissions were provided by the Emission Database for Global Atmospheric Research Hemispheric Transport of Air Pollution version 2 (EDGAR HTAP\_v2) dataset (Edgar 2010) for 2010 with a  $0.1^\circ$  grid mesh size. In addition, the new gas flaring emission from Deetz and Vogel (2017) was used for this study. Biogenic emissions, sea salt, and mineral dust are calculated online within the model, and mean dimethyl sulfide (DMS) monthly fluxes are prescribed after Lana et al. (2011). The initial and boundary conditions for the meteorology were provided from the global Icosahedral Nonhydrostatic (ICON) model of the German Weather Service (Zängl et al. 2015). The boundary data for gaseous and particulate compounds were derived from the Model for Ozone and Related Chemical Tracers (MOZART) (Emmons et al. 2010). The simulation setup used was similar to the one described in Deetz et al. (2018).

### Biomass Burning Experiment

In order to assess the effects of BB over SWA, we carried out two sets of simulations: one with BB emissions (hereafter called Fire) and another one ignoring BB emissions (hereafter called No Fire) for the period under investigation. The experiment with BB includes real-time MODIS observations of fire emissions. Figure 2 presents surface CO emissions for the two case scenarios under investigation.

Due to its long lifetime and its reactivity, CO is used as a surrogate for BB detection. Moderate CO emissions are observed in SWA mostly over the city plumes (Abidjan, Accra, Cotonou, and Lagos) due to local anthropogenic emissions.



**Fig. 2** Biomass burning July fire emissions for the No fire (a, 2016) and Fire (b, 2016) at the surface

Moderate CO emissions are also observed in the Niger Delta (in southwestern Nigeria), probably as a result of gas flaring activities, as well as in northern Nigeria. The peak of the CO emission is observed in Central and Southern Africa, where the BB is taking place.

## Results and Discussion

This section presents the results obtained with regard to BB, by focusing on the impact on meteorology of the study area (section “[Impact on Meteorology](#)”), the impact on the atmospheric composition (section “[Impact on the Atmospheric Composition](#)”), and the adaptation and mitigation strategies proposed (section “[Adaptation and Mitigation Strategies](#)”) as being helpful in reducing the impact of BB in the SWA region.

### Impact on Meteorology

Our period of investigation is July 2016, which was characterized as the post-onset rainy season in SWA (Knippertz et al. 2017), thus favoring an undisturbed monsoon condition. During this period, long-range transport of BB is advected across the Eastern Atlantic Ocean and the Gulf of Guinea by a jet at around 700 hPa. In order to obtain quantitative results, a domain average over D2 (9°W–4°E; 3°–10.8°N), and the difference and relative change between the Fire and No Fire cases were analyzed. The effects of BB on the meteorological field in general (precipitation, temperature, and cloud droplets number) and on surface shortwave (SW) radiation were examined. Table 1 presents the mean effects over the SWA domain according to the variables for Fire and No Fire.

The results revealed a decrease in SW radiation at the surface and top of atmosphere (TOA) by  $6.5 \text{ W m}^{-2}$  and  $5 \text{ W m}^{-2}$ , respectively, a slight decrease in precipitation, and an increase in the Cloud Droplets Number Concentration (CDNC) over SWA. The decrease of surface SW radiation was expected, as aerosols directly reflect or scatter radiation, thus leading to a cooling effect, which in turn reduces the

**Table 1** Mean values of meteorological fields for the Fire and No Fire scenarios, the difference (F-NF) and the change in percentage averaged over the nested domain D2 (9°W–4°E; 3°–10.8°N)

Field	Fire (F)	No Fire (NF)	Difference	% change (F-NF) *100/F)
Precipitation ( $\text{mm day}^{-1}$ )	4.15	4.26	$-0.11 \pm 0.008$	-2.7
SW down surface ( $\text{W m}^{-2}$ )	83.43	89.95	$-6.51 \pm 0.0$	-7.8
Cloud droplet number (CDNC) concentration ( $\text{cm}^{-3}$ )	94,767	85,542	$10,225 \pm 853$	10.78
TOA net downward SW ( $\text{W m}^{-2}$ )	184.61	190.28	$-5 \pm 0.0$	-3.07

atmospheric stability and, thus, the surface fluxes called semi-direct effects. This result agrees with the findings of Thornhill et al. (2018).

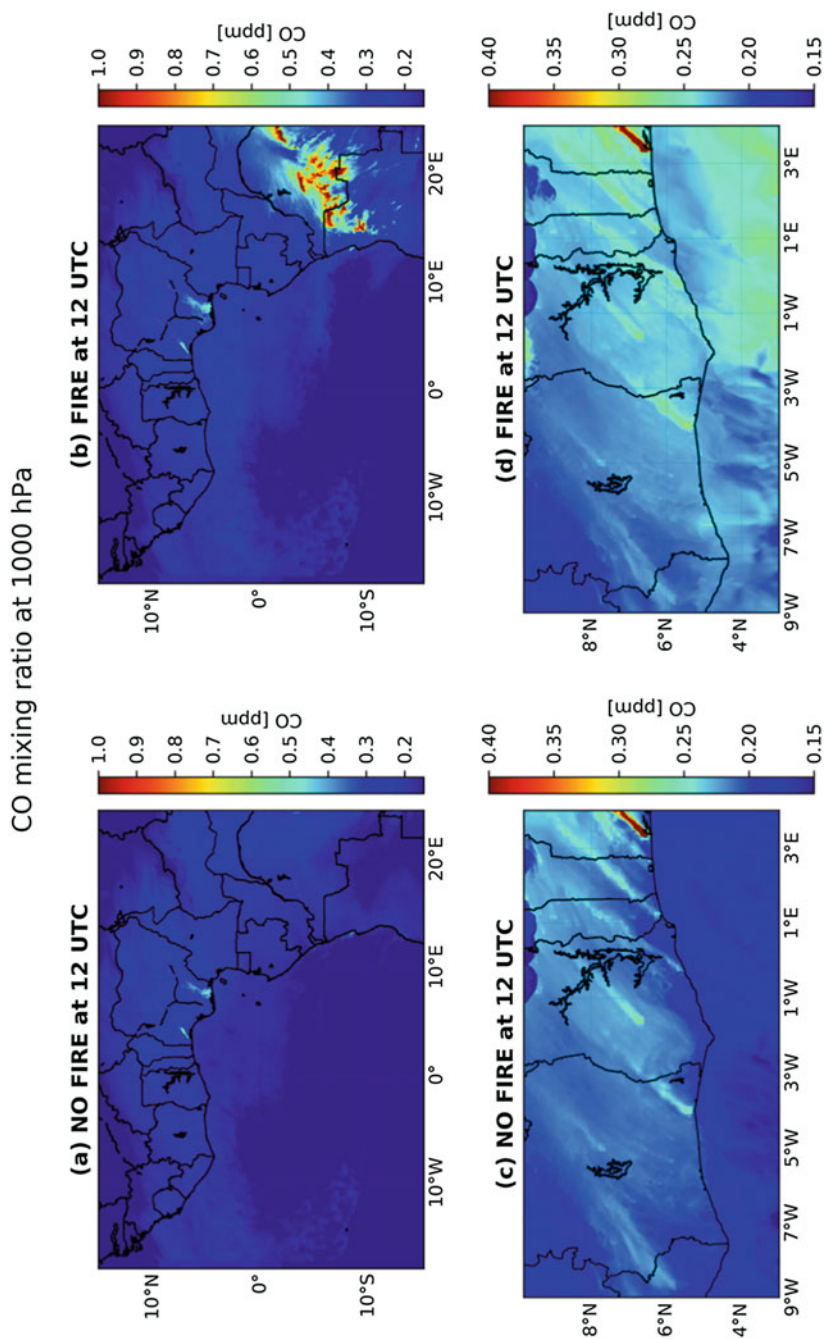
The increase in the CDNC from our model results verifies the Twomey effect (Twomey 1977), which states that an increase in the amount of aerosols leads to a reduction in the cloud droplets size distribution that is associated with an increase in the number concentration.

Our finding corroborates with that of Haslett et al. (2019) which demonstrated that BB aerosols reduce droplet size and increase their number concentration over SWA but less sensitive to precipitation. As a result, more aerosols are competing for water uptake, leading to a reduction in precipitation (known as the Albrecht effect). This result is in agreement with the findings of Thornhill et al. (2018) regarding the impact of BB on precipitation. According to the latter an increase in the number of cloud droplets and a decrease in their size would lead to a decrease in precipitation in the absence of strong convection; however, the decrease here is less compared to their findings.

## Impact on the Atmospheric Composition

In addition to investigating the impact of BB on the local climatology of SWA, this study also examined the relative contribution of BB to the atmospheric composition of SWA. The spatial distribution of the surface CO mixing ratio (ppm) is presented in Fig. 3, over both domains, D1 and D2.

The two upper panels (a, b) depict the contribution of BB in CO concentration; it is marked by high values over Central and Southern Africa where BB occurred (Fig. 3b). Low values of traces of CO concentration can be observed over the Atlantic Ocean. The signature of anthropogenic activities is shown by moderate CO values (0.6 ppm) over Lagos and the Niger Delta in southern Nigeria. The simulated CO concentration over D2 in the lower two panels (c, d) clearly illustrate the plumes above the cities (Abidjan, Accra, Cotonou, Lomé, and Lagos); they show moderate values, except for Lagos, which exhibits the highest CO concentration from both experiments (No Fire and Fire). Kumasi (Ghana), a metropolitan area, also shows a moderate CO concentration as a result of anthropogenic activities. It is worth noting that Kumasi, a city with the third highest population in SWA (3.065 million inhabitants), is one of the most populated area in Ghana (UNO 2018). The CO concentration in SWA cities along the coast is the result of urban pollution. Figure 3d highlights the contribution of BB plumes to the region by showing moderate CO concentrations (0.3 ppm) over the Gulf of Guinea. This is the result of the intrusion of BB air masses into the atmosphere. Indeed, Mari et al. (2008) have shown that BB aerosols are carried aloft and advected westward by a jet at roughly 700 hPa. Layers of BB across SWA, the Gulf of Guinea, and the tropical eastern Atlantic are present during this period of the year (i.e., July 2016) (Chatfield et al. 1998; Mari et al. 2008). The presence of CO from BB in the marine boundary layer mainly arises from subsidence of the aerosols being carried aloft, due to the high pressure area to the west of the African continent (Adebiyi and Zuidema 2016; Flamant et al. 2018). A recent study by Dajuma et al. (2020, in press) demonstrated



**Fig. 3** Surface CO spatial distribution over domain D1 (a, b), respectively, with No fire emissions (a) and Fire emissions (b), and over Domain D2 (c, d), respectively, with No fire emissions (c) and Fire emissions (d) simulated with COSMO-ART

that convective cumulus clouds located over the Gulf of Guinea play a role in the downward mixing of aerosols located at the mid-level troposphere into the PBL. The southerly monsoon flow in the PBL below 700 hPa carries both BB aerosols and urban gases and aerosols northward (Deroubaix et al. 2019; Knippertz et al. 2017).

The relative contribution of BB to the  $PM_{25}$  over urban cities was also examined in our study. Time series of surface concentrations of  $PM_{25}$  examined for the period simulated over four SWA cities. The results, as illustrated in Fig. 4, are presented for Abidjan, Accra, Cotonou, and Lagos, for simulations with No Fire, Fire, and the difference between the two scenarios (Fire – No Fire).

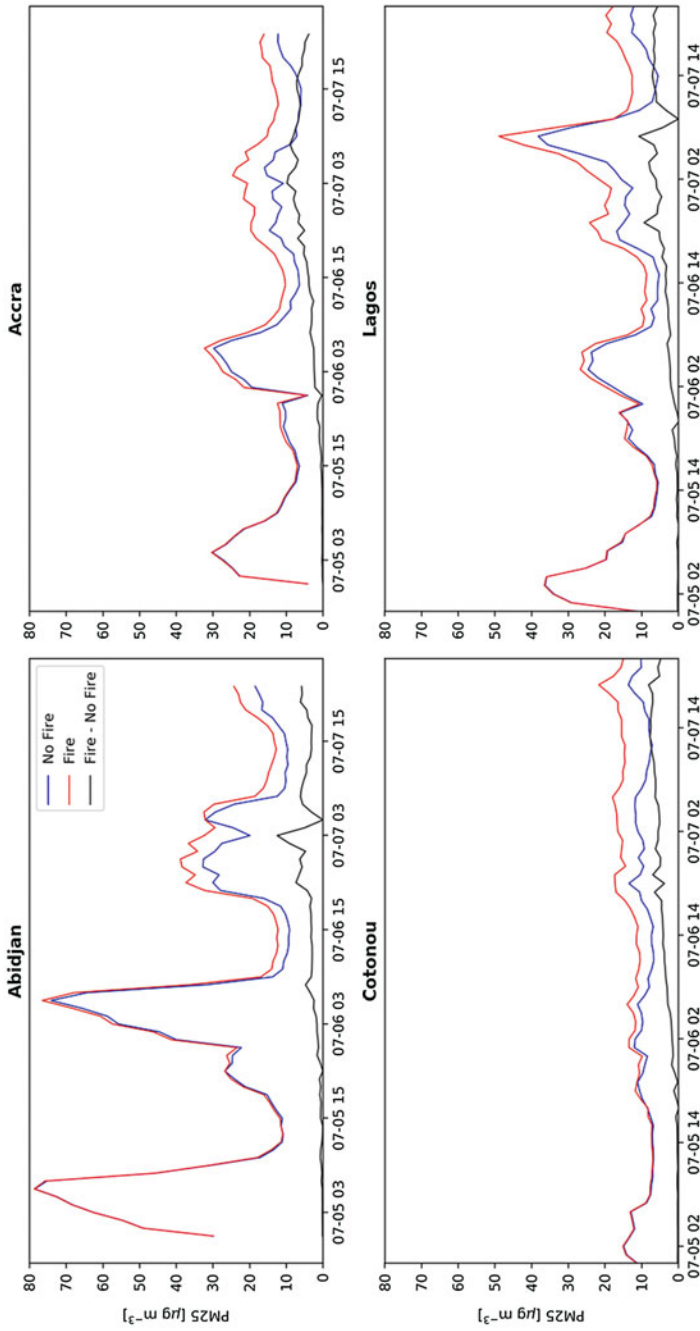
The diurnal cycle shows a peak of  $PM_{25}$  concentration in the early morning around 6 UTC, which begins to decrease after sunrise. The increase of the PBL height results in a mixing of aerosols, highlighted by a decrease with a minimum value around 15 UTC (Fig. 4a). After sunset, the aerosols start to accumulate again. The impact of BB aerosols appears after only 1 day of simulation (from 6 July 2016). For all four cities, the impact of BB has the same order of magnitude, underscoring the wide extent of long-range BB over SWA. The maximum contribution found was  $9.75 \mu\text{g m}^{-3}$ ,  $12.45 \mu\text{g m}^{-3}$ ,  $10.7 \mu\text{g m}^{-3}$ , and  $8 \mu\text{g m}^{-3}$ , respectively, in Accra, Abidjan, Cotonou, and Lagos. Menut et al. (2018) quantified the contribution of BB to the  $PM_{10}$  concentration to be about  $5 \mu\text{g m}^{-3}$  in two SWA cities (Lagos and Abidjan). Although  $PM_{25}$  and  $PM_{10}$  are composed of the same type of aerosols, only at different sizes, it is expected that the contribution to  $PM_{25}$  will be higher (double) than that of  $PM_{10}$ . This confirms that BB aerosols are dominated by the submicron mode, as observed by Haslett et al. (2019).

Our model allowed us to quantify the contributions from each type of aerosol and gases as well. Table 2 thus summarizes the contribution of BB to OC, BC, CO,  $NO_x$ , OZONE, and the Aerosol Optical Depth (AOD).

The relation between AOD and aerosol increase is clearly shown. A 36% increase of AOD from BB contribution is simulated by COSMO-ART highlighting the positive relationship between BB aerosols and AOD, in agreement with the findings of (Reddington et al. 2015). Thus, according to our model results, BB significant effect on AOD.

From the analysis of Table 2, it can be seen that BB plumes increased the atmospheric composition of both gases and aerosols concentrations in SWA. The major contribution of aerosols is from OC, representing a 70% increase due to BB, followed by BC, which accounted for 24.5%. These results agreed with the observations made during the DACCIIWA campaign, which showed that 80% of the aerosol mass concentration in the monsoon layer (below 1.9 km) in SWA was that originated from Central and Southern African BB (Haslett et al. 2019). Also, Menut et al. (2018), through modeling with the Weather Research and Forecasting model coupled with Chemistry (WRF-Chem), found that the contribution of  $PM_{10}$  from BB in Central Africa was mainly composed of primary organic and particulate matter (PM).

Among the gases, the ozone contribution from BB was 16%, followed by CO at 11%, then  $NO_x$  at roughly 8%. Real et al. (2010) found that the BB plume over Central Africa was a source of ozone in the mid-level and upper troposphere. Moreover, Mari et al. (2008), tracing BB aerosol from the southern hemisphere



**Fig. 4** Time series of surface concentrations (in  $\mu\text{g m}^{-3}$ ) of PM25 for Abidjan, Accra, Cotonou, and Lagos: Fire in red, No Fire in blue, and the difference (Fire - No Fire) in black

**Table 2** Mean values of aerosols mass concentration and gas mixing ratio for the Fire and No Fire scenarios, the difference (F-NF), and the change in percentage averaged over the nested domain D2 (9°W–4°E; 3°–10.8°N)

Concentration	Fire (F)	No Fire (NF)	Difference	% change (F-NF)*100/F
AOD	0.39	0.25	0.14 ± 0.01	36
CO (ppb)	225	199	26 ± 1	11.5
OZONE (ppb)	39	33	6 ± 0.3	16
NO <sub>x</sub> (ppb)	26.18	24.1	2.07 ± 0.3	7.98
SOOT (µg m <sup>-3</sup> )	0.196	0.148	0.05 ± 0.004	24.5
OC (µg m <sup>-3</sup> )	3.15	0.93	2.21 ± 0.14	70.32

during the summer monsoon, found ozone production to vary, depending on the meteorological conditions associated with the active and break phases of the southern hemisphere jet.

The presence of BB in the PBL increases the level of air of pollution which increases pollution-related diseases (Lelieveld et al. 2015). Intensive measurements during the DACCIWA campaign in both the dry and wet seasons confirmed that carbonaceous aerosols (OC and BC) were major contributions to particle fractions in Abidjan and Cotonou (Adon et al. 2020). The high content of organic aerosol from BB also has adverse effects on population health throughout the region. For instance, a study by Mauderly and Chow (2008) indicated that organic fractions of ambient PM have adverse respiratory and cardiovascular health outcomes.

## Adaptation and Mitigation Strategies

The detrimental effects of air pollution are recognized worldwide, particularly in West Africa (Knippertz et al. 2015), as this region appears to suffer most from climate change as a result of anthropogenic activities. Increasing levels of local pollution and pollution from remote aerosol sources, such as BB from Central Africa and mineral dust from the Sahel and the Sahara, are increasing the aerosol burden over the SWA region. Consequently, poor air quality exposes the population to serious health risks, particularly people living in the coastal cities. Since urbanization is increasing worldwide, there is a need to implement effective management plans and policies to improve adaptive capacity and mitigate the effects of anthropogenic induced air pollution in SWA. An air quality monitoring network should be established in SWA in order to regulate air quality throughout the region over the long term, as suggested by the DACCIWA policy brief (Evans et al. 2019). This will also help to spread awareness among the population of areas of high pollution thus reducing the prevalence of respiratory illnesses, such as asthma. Local populations should be encouraged to shift from using wood and charcoal for cooking to instead using electricity or gas in order to reduce local emissions. For instance, Adon et al. (2020), focusing on local sources domestic fires in Abidjan, showed that 75% of the total PM are carbonaceous aerosols.

Regionally, negotiations are necessary between Central Africa and West Africa in order to reduce both regions' BB emissions, as recommended by the DACCIWA policy brief (Evans et al. 2019). It is furthermore important to develop air pollution policies in SWA. Weather forecasting is an essential tool to mitigate air pollution-related effects. There is a need to improve weather forecasting in SWA, not only in the meteorological field but also to account for aerosols, as these interact with the climate.

Another recommendation is to promote the use of renewable energy, such as solar, for use in industries to reduce the consumption of fossil fuels, which are also exacerbating air pollution. With regard to transportation, the traffic fleet in the SWA region is dominated by old cars (Dolumbia et al. 2018). Regulations should be implemented to ban the use of old cars and to improve the public transportation systems in SWA, as both are major sources of pollutants.

By means of climate education and the promotion of green lifestyles the local community could be educated, assisted, and encouraged to participate in the mitigation of climate change. And lastly, it is also recommended that increasing observational networks over SWA and improving modeling tools (e.g., cluster) and human capacity would be effective and efficient ways of tackling issues related to climate change.

---

## Conclusions

It has been found in our study that remote pollution from the long-range transport of BB appears to affect the atmospheric aerosol pollution over SWA during summer monsoon. BB plumes originate from Central and Southern Africa as a result of agricultural activities, land management, livestock grazing, and crop production. They are carried westward by a jet toward the tropical eastern Atlantic Ocean, the Gulf of Guinea and SWA in the mid-level troposphere. BB aerosols were shown to increase the concentration of PM over four coastal cities in SWA in the same range of magnitude. Increase in  $PM_{25}$  of  $12.45 \mu\text{g m}^{-3}$ ,  $9.75 \mu\text{g m}^{-3}$ ,  $8 \mu\text{g m}^{-3}$ , and  $10.7 \mu\text{g m}^{-3}$  was simulated, respectively, for Abidjan, Accra, Lagos, and Cotonou. Observational studies have shown that  $PM_{25}$  aerosols measured in the ADF, for instance, have exceeded the limits set by the World Health Organisation (WHO) limit (Djossou et al. 2018).

Relative contributions of BB to gaseous pollutants such as  $NO_x$ , CO, and Ozone are, respectively, 7.98%, 11.5%, and 16%. As far as aerosols are concerned, OC is the dominant contributor to the atmospheric composition from BB with a 70% increase, followed by BC with a 24% increase. The AOD change as a result of BB aerosol is estimated at 36%.

Regarding the effect on climate, it was found that SW radiation decreased by  $6.5 \text{ W m}^{-2}$  at the surface and  $5 \text{ W m}^{-2}$  at the TOA. The mean domain average of CDNC increased by 11% from the No Fire to the Fire case scenario, followed by a slight decrease in precipitation. It is worth noting that this experiment was conducted only over a few days. However, the results do emphasize that there is a need to



explore further and obtain more robust results by performing long-term simulations. Based on the results obtained with our model, it is obvious that BB aerosols from the southern hemisphere of Africa are interacting with the WAM dynamics; these interactions need to be investigated in future studies.

In addition, there is a need to implement an air pollution monitoring system to tackle health problems related to pollution and increase the adaptive capacity of West Africa to climate change by limiting local pollution. Moreover, there is a need to implement transboundary agreements in policies making, for example, by collaborating with countries in Central Africa to reduce their emissions from vegetation fires, as suggested by the DACCIWA policy brief (Evans et al. 2019).

---

## References

- Adebisi AA, Zuidema P (2016) The role of the southern African easterly jet in modifying the Southeast Atlantic aerosol and cloud environments. *Q J R Meteorol Soc.* <https://doi.org/10.1002/qj.2765>
- Adon AJ, Lioussé C, Doumbia ET, Baeza-Squiban A et al (2020) Physico-chemical characterization of urban aerosols from specific combustion sources in West Africa at Abidjan in Côte d'Ivoire and Cotonou in Benin in the frame of the DACCIWA program. *Atmos Chem Phys* 20: 5327–5354. <https://doi.org/10.5194/acp-20-5327-2020>
- Athanasopoulou E, Vogel H, Vogel B et al (2013) Modeling the meteorological and chemical effects of secondary organic aerosols during an EUCAARI campaign. *Atmos Chem Phys* 13:625–645. <https://doi.org/10.5194/acp-13-625-2013>
- Bangert M, Nenes A, Vogel B et al (2012) Saharan dust event impacts on cloud formation and radiation over Western Europe. *Atmos Chem Phys* 12:4045–4063. <https://doi.org/10.5194/acp-12-4045-2012>
- Barbosa PM, Stroppiana D, Grégoire JM, Pereira JMC (1999) An assessment of vegetation fire in Africa (1981–1991): burned areas, burned biomass, and atmospheric emissions. *Global Biogeochem Cycles.* <https://doi.org/10.1029/1999GB900042>
- Bowman DMJS, Balch J, Artaxo P et al (2011) The human dimension of fire regimes on earth. *J Biogeogr* 38:2223–2236. <https://doi.org/10.1111/j.1365-2699.2011.02595.x>
- Chatfield RB, Vastano JA, Li L et al (1998) The Great African Plume from biomass burning: generalizations from a three-dimensional study of TRACE A carbon monoxide. *J Geophys Res Atmos* 103:28059–28077. <https://doi.org/10.1029/97JD03363>
- Dajuma A, Ogunjobi KO, Vogel H et al (2020) Downward cloud venting of the central African biomass burning plume during the West Africa summer monsoon. *Atmos Chem Phys* 20:5373–5390. <https://doi.org/10.5194/acp-5373-2020>
- Deetz K, Vogel B (2017) Development of a new gas-flaring emission dataset for southern West Africa. *Geosci Model Dev* 10:1607–1620. <https://doi.org/10.5194/gmd-10-1607-2017>
- Deetz K, Vogel H, Knippertz P et al (2018) Numerical simulations of aerosol radiative effects and their impact on clouds and atmospheric dynamics over southern West Africa. *Atmos Chem Phys* 18:9767–9788. <https://doi.org/10.5194/acp-18-9767-2018>
- Deroubaix A, Flamant C, Menut L et al (2018) Interactions of atmospheric gases and aerosols with the monsoon dynamics over the Sudano-Guinean region during AMMA. *Atmos Chem Phys* 18:445–465. <https://doi.org/10.5194/acp-18-445-2018>
- Deroubaix A, Menut L, Flamant C et al (2019) Diurnal cycle of coastal anthropogenic pollutant transport over southern West Africa during the DACCIWA campaign. *Atmos Chem Phys* 19:473–497. <https://doi.org/10.5194/acp-19-473-2019>
- Djossou J, Léon JF, Barthélemy AA et al (2018) Mass concentration, optical depth and carbon composition of particulate matter in the major southern West African cities of Cotonou (Benin)

- and Abidjan (Côte d'Ivoire). *Atmos Chem Phys* 18:6275–6291. <https://doi.org/10.5194/acp-18-6275-2018>
- Doumbia M, Toure NE, Silue S et al (2018) Emissions from the road traffic of West African cities: assessment of vehicle fleet and fuel consumption. *Energies* 11:1–16. <https://doi.org/10.3390/en11092300>
- Edgar (2010) EDGAR – Emission Database for Global Atmospheric Research. Glob Emiss EDGAR v42 (November 2011). <https://doi.org/10.2904/EDGARv4.2>
- Emmons LK, Walters S, Hess PG et al (2010) Description and evaluation of the Model for Ozone and Related chemical Tracers, version 4 (MOZART-4). *Geosci Model Dev* 3:43–67. <https://doi.org/10.5194/gmd-3-43-2010>
- Evans MJ, Knippertz P, Aristide A, Allan RP (2019) Policy-relevant findings of the DACCIWA. <https://doi.org/10.5281/zenodo.1476843>
- Flamant C, Deroubaix A, Chazette P et al (2018) Aerosol distribution in the northern Gulf of Guinea: local anthropogenic sources, long-range transport, and the role of coastal shallow circulations. *Atmos Chem Phys* 18:12363–12389. <https://doi.org/10.5194/acp-18-12363-2018>
- Hao WM, Liu MH (1994) Spatial and temporal distribution of tropical biomass burning. *Global Biogeochem Cycles*. <https://doi.org/10.1029/94GB02086>
- Haslett SL, Taylor JW, Evans M et al (2019) Remote biomass burning dominates southern West African air pollution during the monsoon. *Atmos Chem Phys* 19:15217–15234. <https://doi.org/10.5194/acp-19-15217-2019>
- Huang J, Adams A, Wang C, Zhang C (2013) Black Carbon and West African Monsoon precipitation: observations and simulations. *Ann Geophys* 27:4171–4181
- Huang X, Ding A, Liu L et al (2016) Effects of aerosol-radiation interaction on precipitation during biomass-burning season in East China. *Atmos Chem Phys* 16:10063–10082. <https://doi.org/10.5194/acp-16-10063-2016>
- Jiang Y, Lu Z, Liu X et al (2016) Impacts of global open-fire aerosols on direct radiative, cloud and surface-albedo effects simulated with CAM5. *Atmos Chem Phys* 16:14805–14824. <https://doi.org/10.5194/acp-16-14805-2016>
- Kaiser JW, Heil A, Andreae MO et al (2012) Biomass burning emissions estimated with a global fire assimilation system based on observed fire radiative power. *Biogeosciences* 9:527–554. <https://doi.org/10.5194/bg-9-527-2012>
- Knippertz P, Evans MJ, Field PR et al (2015) The possible role of local air pollution in climate change in West Africa. *Nat Clim Chang* 815–822. <https://doi.org/10.1038/nclimate2727>
- Knippertz P, Fink AH, Deroubaix A et al (2017) A meteorological and chemical overview of the DACCIWA field campaign in West Africa in June–July 2016. *Atmos Chem Phys* 17:10893–10918. <https://doi.org/10.5194/acp-17-10893-2017>
- Knote C, Brunner D, Vogel H et al (2010) Online-coupled chemistry and aerosols: COSMO-ART model performance
- Lana A., Bell T. G., Simó R., et al (2011) An updated climatology of surface dimethylsulfide concentrations and emission fluxes in the global ocean. *Global Biogeochem Cycles* 25:1–17. <https://doi.org/10.1029/2010GB003850>
- Lelieveld J, Fnais M, Evans JS et al (2015) The contribution of outdoor air pollution sources to premature mortality on a global scale. *Nature* 525:367–371. <https://doi.org/10.1038/nature15371>
- Marengo A, Medale JC, Prieur S (1990) Study of tropospheric ozone in the tropical belt (Africa, America) from STRATOZ and TROPOZ campaign. *Atmos Environ* 24:2823–2834. [https://doi.org/10.1016/0960-1686\(90\)90169-N](https://doi.org/10.1016/0960-1686(90)90169-N)
- Mari CH, Cailley G, Corre L et al (2008) Tracing biomass burning plumes from the Southern Hemisphere during the AMMA 2006 wet season experiment. *Atmos Chem Phys* 8:3951–3961. <https://doi.org/10.5194/acp-8-3951-2008>
- Mauderly JL, Chow JC (2008) Health effects of organic aerosols. *Inhal Toxicol* 20:257–288. <https://doi.org/10.1080/08958370701866008>
- Mbow C, Nielsen TT, Rasmussen KC (2000) Savanna fires in East-Central Senegal: distribution patterns, resource management and perceptions. *Hum Ecol* 28(4):561–583

- Menut L, Flamant C, Turquety S et al (2018) Impact of biomass burning on pollutant surface concentrations in megacities of the Gulf of Guinea. *Atmos Chem Phys* 18:2687–2707. <https://doi.org/10.5194/acp-18-2687-2018>
- N'Datchoh ET, Konaré A, Diedhiou A et al (2015) Effects of climate variability on savannah fire regimes in West Africa. *Earth Syst Dynam* 6:161–174. <https://doi.org/10.5194/esd-6-161-2015>
- Pani SK, Wang SH, Lin NH et al (2016) Radiative effect of springtime biomass-burning aerosols over northern Indochina during 7-SEAS/BASELInE 2013 campaign. *Aerosol Air Qual Res* 16:2802–2817. <https://doi.org/10.4209/aaqr.2016.03.0130>
- Real E, Orlandi E, Law KS et al (2010) Cross-hemispheric transport of central African biomass burning pollutants: implications for downwind ozone production. *Atmos Chem Phys* 10:3027–3046. <https://doi.org/10.5194/acp-10-3027-2010>
- Reddington CL, Butt EW, Ridley DA et al (2015) Air quality and human health improvements from reductions in deforestation-related fire in Brazil. *Nat Geosci* 8:768–771. <https://doi.org/10.1038/ngeo2535>
- Stowe LL, Jacobowitz H, Ohring G et al (2002) The advanced very high resolution radiometer (AVHRR) pathfinder atmosphere (PATMOS) climate dataset: initial analyses and evaluations. *J Clim* 15:1243–1260. [https://doi.org/10.1175/1520-0442\(2002\)015<1243:TAVHRR>2.0.CO;2](https://doi.org/10.1175/1520-0442(2002)015<1243:TAVHRR>2.0.CO;2)
- Swap RJ, Annegarn HJ, Suttles JT et al (2002) The southern African regional science initiative (SAFARI 2000): overview of the dry season field campaign. *S Afr J Sci* 98:125–130
- Thornhill GD, Ryder CL, Highwood EJ et al (2018) The effect of south American biomass burning aerosol emissions on the regional climate. *Atmos Chem Phys* 18:5321–5342. <https://doi.org/10.5194/acp-18-5321-2018>
- Twomey S (1977) The influence of pollution on the shortwave albedo of clouds. *J Atmos Sci* 34:1149–1152. [https://doi.org/10.1175/1520-0469\(1977\)034<1149:TIOPOP>2.0.CO;2](https://doi.org/10.1175/1520-0469(1977)034<1149:TIOPOP>2.0.CO;2)
- UNO (2018) The world's cities in 2018. <https://doi.org/10.18356/c93f4dc6-en>
- Vogel B, Vogel H, Bäumer D et al (2009) The comprehensive model system COSMO-ART – radiative impact of aerosol on the state of the atmosphere on the regional scale. *Atmos Chem Phys* 9:8661–8680. <https://doi.org/10.5194/acp-9-8661-2009>
- Walter C, Freitas SR, Kottmeier C et al (2016) The importance of plume rise on the concentrations and atmospheric impacts of biomass burning aerosol. *Atmos Chem Phys* 16:9201–9219. <https://doi.org/10.5194/acp-16-9201-2016>
- Zängl G, Reinert D, Rípodas P, Baldauf M (2015) The ICON (ICOsahedral non-hydrostatic) modelling framework of DWD and MPI-M: description of the non-hydrostatic dynamical core. *Q J R Meteorol Soc* 141:563–579. <https://doi.org/10.1002/qj.2378>

**Open Access** This chapter is licensed under the terms of the Creative Commons Attribution 4.0 International License (<http://creativecommons.org/licenses/by/4.0/>), which permits use, sharing, adaptation, distribution and reproduction in any medium or format, as long as you give appropriate credit to the original author(s) and the source, provide a link to the Creative Commons license and indicate if changes were made.

The images or other third party material in this chapter are included in the chapter's Creative Commons license, unless indicated otherwise in a credit line to the material. If material is not included in the chapter's Creative Commons license and your intended use is not permitted by statutory regulation or exceeds the permitted use, you will need to obtain permission directly from the copyright holder.





# Precipitation Variability in West Africa in the Context of Global Warming and Adaptation Recommendations

# 74

Gandome Mayeul L. D. Quenum, Nana A. B. Klutse, Eric A. Alamo, Emmanuel A. Lawin, and Philip G. Oguntunde

## Contents

Introduction .....	1534
Description of the Study Areas and Methodology .....	1536
Study Area and Data Sources .....	1536
Methodology .....	1537
Results .....	1540
Variability of PCI .....	1540
Variability of PCD and PCP .....	1544
Daily Precipitation Variability .....	1544
Adaptation Strategies .....	1549
Discussion and Conclusion .....	1550
References .....	1551

This chapter was previously published non-open access with exclusive rights reserved by the Publisher. It has been changed retrospectively to open access under a CC BY 4.0 license and the copyright holder is “The Author(s)”. For further details, please see the license information at the end of the chapter.

G. M. L. D. Quenum (✉)

West African Science Service Centre for Climate Change and Adapted Land Use (WASCAL)  
Graduate Research Program in West African Climate System (GRP-WACS), Federal University of  
Technology, Akure (FUTA), Akure, Nigeria

Laboratory of Applied Hydrology (LHA), National Institute of Water (NIW), Cotonou, Bénin  
e-mail: [malgdaq2000@yahoo.fr](mailto:malgdaq2000@yahoo.fr)

N. A. B. Klutse

Ghana Space Science and Technology Institute, Atomic Energy Commission, Accra, Ghana

E. A. Alamo · E. A. Lawin

Laboratory of Applied Hydrology (LHA), National Institute of Water (NIW), Cotonou, Bénin

P. G. Oguntunde

Department of Agricultural and Environmental Engineering, Federal University of Technology,  
Akure, Nigeria

© The Author(s) 2021

W. Leal Filho et al. (eds.), *African Handbook of Climate Change Adaptation*,  
[https://doi.org/10.1007/978-3-030-45106-6\\_85](https://doi.org/10.1007/978-3-030-45106-6_85)

1533

---

**Abstract**

It is commonly accepted that the Earth's climate is changing and will continue to change in the future. Rising temperatures are one of the direct indicators of global climate change. To investigate how the rising global temperature will affect the spatial pattern of rainfall in West Africa, the precipitation and potential evapotranspiration variables from ten Global Climate Models (GCMs) under the RCP8.5 scenario were driven by the Rossby Centre regional atmospheric model (RCA4) from the COordinated Regional Climate Downscaling EXperiment (CORDEX) and analyzed at four specific global warming levels (GWLs) (i.e., 1.5 °C, 2.0 °C, 2.5 °C, and 3.0 °C) above the preindustrial level. This study utilized three indices, the precipitation concentration index (PCI), the precipitation concentration degree (PCD), and the precipitation concentration period (PCP) over West Africa to explore the spatiotemporal variations in the characteristics of precipitation concentrations. Besides, the analysis of the effect of the specified GWLs on the Consecutive Dry Days (CDD), Consecutive Wet Days (CWD), and frequency of the intense rainfall events allowed to a better understanding of the spatial and temporal patterns of extreme precipitation in West Africa. Results reveal that, for the projections simulations and at each GWL, the rainfall onset starts one month earlier in the Gulf of Guinea in response to the control period. To encourage adaptation to the various changes in climate in general, and particularly in respect of rainfall, this study proposes several adaptation methods that can be implemented at the local (country) level, as well as some mitigation and adaptation strategies at the regional (West African) level.

---

**Keywords**

Precipitation concentration index (PCI) · Precipitation concentration degree (PCD) · Precipitation concentration period (PCP) · Adaptation strategy · Global warming

---

**Introduction**

Precipitation variability and concentration are two important climate factors with an impact on society, agriculture, and the environment, as increased precipitation variability can reduce agricultural yields (Rowhani et al. 2011). Also, precipitation variability is strongly connected to extreme wet and dry events, floods, and droughts, which pose threats to the environment and to society, and can also have devastating consequences on ecosystems, food supplies, and economies at the local, regional, and global scale (Easterling et al. 2000). In its 5th report, the Intergovernmental Panel on Climate Change (IPCC) stresses that there is an increase in the number of extreme weather events for the twenty first century due to climate change (IPCC 2014). As temperatures rise, the amount of water vapor in the atmosphere also increases and the spatiotemporal distributions of precipitation change, resulting in significant differences in precipitation across the world (Chou and Lan 2011;

Gao et al. 2014). Obtaining real-time information and facilitating earlier predictions by decision makers can be an efficient tool to adapt and to mitigate the impacts of climate events. However, this is an especially challenging task over data-sparse regions as West Africa, where unreliable monitoring networks and generally low institutional capacity limits the spread of timely information (Sheffield et al. 2014).

To assess the spatial and temporal variability of precipitation, various methods were adopted and documented. Precipitation concentration plays an important role, firstly, with regard to the annual total precipitation amount days and, secondly, with regard to the time and degree of concentration of the yearly total precipitation within a year. This variable has the potential to cause floods and drought events, both of which are expected to put considerable pressure on water resources (Zhang and Qian 2003; Zhang et al. 2009). Several studies have been interested in the importance of precipitation concentration indices. The present study adopted three of them: (i) the precipitation concentration index (PCI), which was developed by Oliver (1980); and years after was modified by De Luis et al. (2011). It has been used by Shi et al. (2015) as an indicator of the rainfall concentration for annual and seasonal scales, and Ezenwaji et al. (2017) to investigate the implications of the concentration and variability of rainfall on flooding over Awka Urban Area (Nigeria). (ii) The precipitation concentration degree (PCD) and (iii) the precipitation concentration period (PCP), which were redefined by Zhang and Qian (2003) in a study of droughts and floods in the Yangtze River valley (China). The basic concept behind the PCD and PCP is that the monthly total precipitation is a vector quantity with both magnitude and direction (Li et al. 2011; Wang et al. 2013).

In order to investigate and understand future climates, scientists refer to climate scenarios to provide a plausible explanation of how the future may evolve with respect to a number of variables, including socioeconomic change, technological change, energy and land-use, and the emissions of greenhouse gasses (GHGs) and air pollutants (Van Vuuren et al. 2011). Many factors are taken into account in order to predict how future global warming will contribute to climate change. A key variable is future GHG emissions. Some studies over West Africa (e.g., Egbebiyi 2016; Haensler et al. 2013; Sylla et al. 2012) have shown that projected increases in global GHG concentrations will lead to an increase in the frequency and intensity of extreme rainfall events (Klutse et al. 2018). So, for the meeting by the Intergovernmental Panel on Climate Change (IPCC) in 2007, four RCP radiative forcing levels were retained (Moss et al. 2008). The Representative Concentration Pathway (RCP) is defined as the trajectories relating to GHG concentrations, and was projected by the IPCC in 2014. The four Representative Concentration Pathways (RCPs), namely, RCP2.6, RCP4.5, RCP6, and RCP8.5, are labeled after a possible range of radiative forcing values up to the year 2100 (2.6, 4.5, 6.0, and 8.5 W/m<sup>2</sup>, respectively).

In 2010, the sixteenth session of the Conference of the Parties (COP16) adopted the Cancun Agreement for keeping the global temperature rise below 2.0 °C (UNFCCC 2010). A few years later, in 2015, at Paris, the COP21 proposed an ambitious target, which is to keep the increase in global average temperature to well below 2.0 °C above preindustrial levels, while pursuing efforts to limit the temperature increase to 1.5 °C. The rate of climate change is an important issue for mitigation and/or adaptation policies (Watkiss et al. 2015). Many studies have

recently examined regional risks for the whole of Africa, as well some of its regions, such as Southern Africa and West Africa, at various global warming levels (GWLs). Recently, Déqué et al. (2017) suggested a classification of global warming for all the RCPs and for GWLs from 1.5 °C to 4 °C. Based on Déqué et al.'s (2017) suggestion, several studies (Abiodun et al. 2019; Klutse et al. 2018; Kumi and Abiodun 2018; Maüre et al. 2018; Nikulin et al. 2018) were done to assess the impact of different GWLs on various climate variables.

Mitigation and adaptation are two fundamental societal response options to deal with the problem of climate change (IPCC 2001; Füssel 2007; Locatelli 2011). The community of climate change scientists has focused mainly on mitigation rather than adaptation; for a long time, the latter has been ignored in the debate on climate change (Füssel 2007; De Perthuis et al. 2010). Mitigation policies have already been adopted at the international level, since it is clear that the global climate is already changing and will continue to change in the future due to anthropogenic GHG and aerosol emissions; it is thus important to make adjustments all the more urgently, especially at a local level (Füssel 2007; De Perthuis et al. 2010). In addition, though, there is a need to focus the debate on adaptation measures to climate change in order to prepare communities, especially the most vulnerable ones, to cope with its impacts (Kpadonou et al. 2012).

Identification of a suitable methodology to assess the spatiotemporal precipitation distribution is vital for planning effective adaptation and mitigation strategies to overcome potential drought and flood situations. Selecting the optimal methodology or tools may be useful for planning disaster management and preparedness to respond to droughts and floods, and to mitigate their effects on the activities in different sectors of the economy. Therefore, this study aims to use the analyses of PCI, PCD, PCP, consecutive dry days (CDD), and consecutive wet days (CWD) to explain the spatial and temporal variability of precipitation in West Africa in the context of GWLs 1.5 °C, 2.0 °C, 2.5 °C, and 3.0 °C.

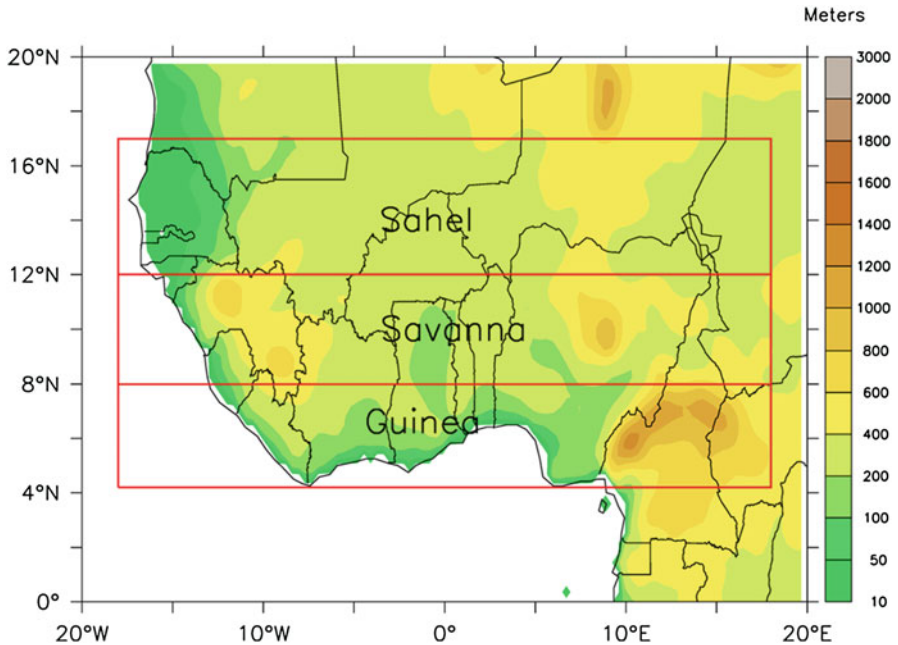
---

## Description of the Study Areas and Methodology

This section describes the study area and the data used (section “[Study Area and Data Sources](#)”), and the methodology that was applied (section “[Methodology](#)”) to arrive at the results.

### Study Area and Data Sources

The study area lies in West Africa, which is located between latitudes 0° N and 20° N and longitudes 20° W and 20° E (Fig. 1). This region is bordered in the South by the Gulf of Guinea, in the north by Mauritania, Mali, and Niger; the Cameroon highlands form the eastern boundary, while the Atlantic Ocean forms the western limit. The annual mean temperature is about 18 °C, but the monthly mean can be more than 40 °C over the southern part of the Sahara. Rainfall patterns over this region are mostly affected by ocean currents and local features, such as topography.



**Fig. 1** Study domain showing the West African topography and the area of focus, which comprises the Gulf of Guinea (Guinea), the Savanna, and the Sahel zones (Diasso and Abiodun 2015)

In terms of climatic zones, West Africa can be divided into three different regions. The first region covers the Sahel and is characterized as a semiarid zone ranging from western Senegal to eastern Sudan, between 12°N and 20°N. The second region is the Sudano-Sahelian zone, while the last and the third comprises the Guinea coast, which is characterized by a bimodal mode driven by the Intertropical discontinuity (ITD).

Precipitation and potential evapotranspiration variables from CORDEX are used in this study. Data from CORDEX are driven by RCA4 at daily and monthly timesteps. The simulated dataset used was collected from the coordinated regional climate downscaling experiment (CORDEX) (Nikulin et al. 2012), and has a horizontal resolution of  $0.44^\circ \times 0.44^\circ$ . The period of 1971–2000 was extracted from the simulated dataset as the historical period, while the period of 2006–2100 was used for projections. This study focuses specifically on the GWLs of 1.5 °C, 2.0 °C, 2.5 °C, and 3.0 °C above the preindustrial levels and under the RCP8.5 scenario. The 30-year projection according to each GWL can be found in Table 1.

## Methodology

The PCI is calculated in the section “[Calculation of Precipitation Concentration Index \(PCI\)](#)” to classify how the rainfall is spatially distributed, and the PCD and PCP in the section “[Computation of Precipitation Concentration Degree \(PCD\) and Precipitation](#)



**Table 1** Recapitulative of the selected years for the ten GCMs drove by RCA4 model according to each global warming level. (Adapted by Quenum et al. 2019 from Déqué et al. 2017)

		RCP85			
RCM	GCM	1.5 °C	2.0 °C	2.5 °C	3.0 °C
RCA4	CanESM2	1999–2028	2012–2041	2024–2053	2034–2063
	CNRM-CM5	2015–2044	2029–2058	2041–2070	2052–2081
	CSIRO-Mk3	2018–2047	2030–2059	2040–2069	2050–2079
	EC-EARTH-r12	2005–2034	2021–2050	2034–2063	2047–2076
	GFDL-ESM2M	2020–2049	2037–2066	2052–2081	2066–2095
	HadGEM2-ES	2010–2039	2023–2052	2033–2062	2042–2071
	IPSL-CM5A-MR	2002–2031	2016–2045	2027–2056	2036–2065
	MIROC5	2019–2048	2034–2063	2047–2076	2058–2087
	MPI-ESM-LR	2004–2033	2021–2050	2034–2063	2059–2088
	NorESM1-M	2019–2048	2034–2063	2047–2076	2059–2088

**Concentration Period (PCP)**” were designed to determine, respectively, the period (months) and the degree of the concentration of the precipitation during the year.

### Calculation of Precipitation Concentration Index (PCI)

The PCI, which was developed by Oliver (1980), modified by De Luis et al. (2011) and also used by Shi et al. (2015), was used as an indicator of rainfall concentration for annual and seasonal scales (wet and dry seasons). In our study, the PCI was tested to identify future trends in respect of the spatial distribution of rainfall. According to Oliver (1980), PCI values of less than 10 represent a uniform precipitation distribution (i.e., a low precipitation concentration), values between 11 and 15 denote a moderate precipitation concentration, values from 16 to 20 denote an irregular distribution, and values above 20 represent a strong irregularity of precipitation distribution (i.e., a high precipitation concentration). The following equations were used on each grid point to calculate the PCIs:

$$PCI_{\text{annual}} = \frac{\sum_{i=1}^{12} P_i^2}{\left(\sum_{i=1}^{12} P_i\right)^2} \times 100 \quad (1)$$

$$PCI_{\text{wet}} = \frac{\sum_{i=1}^{nw} P_i^2}{\left(\sum_{i=1}^{nw} P_i\right)^2} \times \frac{100 * nw}{12} \quad (2)$$

$$PCI_{\text{dry}} = \frac{\sum_{i=1}^{nd} P_i^2}{\left(\sum_{i=1}^{nd} P_i\right)^2} \times \frac{100 * nd}{12} \quad (3)$$

Equation 1 was used for annual PCI, while Equations 2 and 3 were utilized for seasonal scales (rainy and dry seasons, respectively);  $nw$  and  $nd$  represent, respectively, the number of rainy and dry season months, and  $P =$  precipitation of the  $i^{\text{th}}$  month. In order to investigate changes in the PCI, a 30-year period was considered both for historical and future periods. Table 1 shows the projection periods used for each GWL; the historical 30-year period is 1971–2000.

### Computation of Precipitation Concentration Degree (PCD) and Precipitation Concentration Period (PCP)

The PCD and PCP were proposed by Zhang and Qian (2003) to measure the distribution of rainfall and the peak of its concentration date. The basic principle is based on the vector of daily or monthly total precipitation. The assumption can be made that at a time scale (daily, 5-day, weekly, decade or monthly) total precipitation is a vector quantity with both magnitude and direction and can be illustrated as a circle ( $360^\circ$ ). According to Li et al. (2011) and Zhang and Qian (2003), the indices were calculated as follows:

$$\theta_j = \left( 360^\circ * \frac{j}{n} \right) \quad (4)$$

$$R_i = \sum r_{ij} \quad (5)$$

$$R_{xi} = \sum_{j=1}^N r_{ij} * \sin \theta_j \quad (6)$$

$$R_{yi} = \sum_{j=1}^N r_{ij} * \cos \theta_j \quad (7)$$

$$PCD_i = \frac{\sqrt{R_{xi}^2 + R_{yi}^2}}{R_i} \quad (8)$$

where  $i$  is the year (e.g., for the historical period  $i = 1971, 1972, \dots, 2000$ ),  $j$  represents the time scale (**daily**, 5-day, weekly, decade, or **monthly**) of that year,  $R_i$  is the amount of rainfall of a year,  $r_{ij}$  is the precipitation of the  $j^{\text{th}}$  time scale in the  $i^{\text{th}}$  year,  $n$  is the number of time scales per year (e.g., daily: for a non-leap year,  $n = 365$ , while in a leap year,  $n = 366$ )

$$\alpha_i = \tan^{-1} \left( \frac{R_{xi}}{R_{yi}} \right) \quad (9)$$

$$D_i = \begin{cases} \alpha_i (R_{yi} > 0, R_{xi} \geq 0) \\ \alpha_i (R_{yi} > 0, R_{xi} < 0) \\ \alpha_i (R_{xi} < 0) \end{cases} \quad (10)$$

$$PCP_i = D_i * \left( \frac{n}{360^\circ} \right) \quad (11)$$

The next section discusses the results obtained with regard to the three indices above mentioned.

---

## Results

This section presents the results obtained from the study. Based on the variability between the historical period (1971–2000, also referred to as the control period, CTL) and the various GWLs periods the section “[Annual Precipitation Concentration](#)” shows the annual precipitation concentration patterns, while the section “[Seasonal Precipitation Concentration](#)” focuses on the seasonal PCI variabilities. The section “[Evaluation of the Models’ Robustness](#)” investigates the robustness of the models to assess the PCI over West Africa. The period and the degree of the concentration of the rainfall are evaluated in the section “[Variability of PCD and PCP](#)”, while the section “[Daily Precipitation Variability](#)” shows the daily consecutive precipitation variability. Finally, the adaptation processes proposed are explained in section “[Adaptation Strategies.](#)”

### Variability of PCI

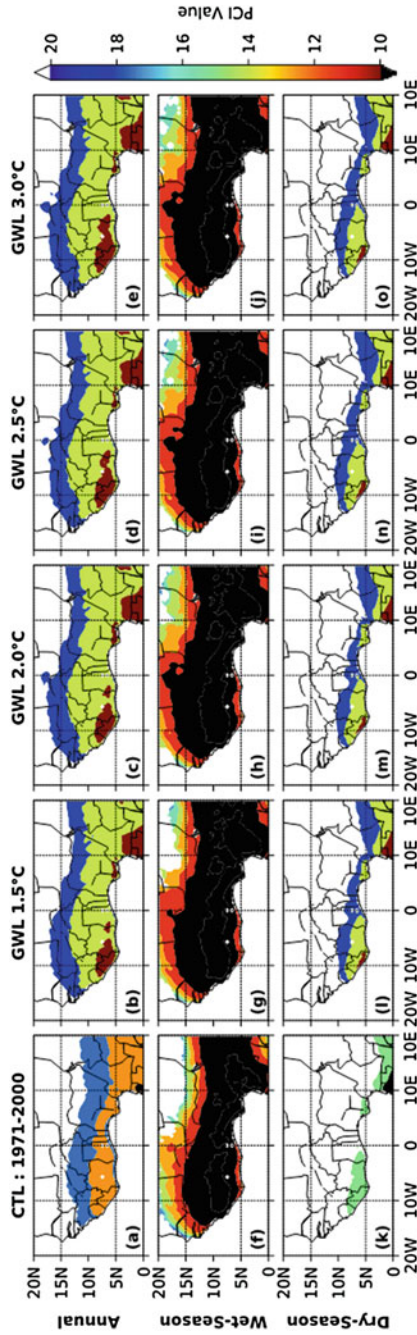
The variability of the PCI is investigated in sections “[Annual Precipitation Concentration](#)” and “[Seasonal Precipitation Concentration,](#)” respectively, for the annual and seasonal time scales.

#### Annual Precipitation Concentration

The variability of the PCI computed across West Africa at an annual scale is between 12 and above 20 (Fig. 2a–e). According to a classification established by Oliver (1980), this high variability of the PCI values over West Africa illustrates the existence of a seasonal rainfall regime. Lower values (between 12 and 13) are noticed for the simulation of the historical period over the Gulf of Guinea, which means that this region of the study domain has a moderate precipitation concentration when interested in the distribution at the annual scale. The seasonality is more pronounced in the Savanna with PCI range between 17 and 18 (according to Oliver’s (1980), this explains how the precipitation is irregularly distributed both spatially and temporally). Lastly, the Sahel region recorded a high precipitation concentration ( $PCI > 20$ ), which means that the precipitation is strongly irregularly distributed. For the specified GWLs, it is illustrated in Fig. 2a–e that for the Gulf of Guinea and the Savanna, the precipitation concentration is irregularly distributed except for some countries like Côte d’Ivoire and Liberia which have a low PCI.

#### Seasonal Precipitation Concentration

There are two major seasons over the study area. For the purposes of this analysis, the rainy season is assumed to last from early May to the end of September (MJJAS).



**Fig. 2** Variability of Precipitation Concentration Index (PCI) at annual and seasonal scales for the historical period (CTL: 1971–2000) and for projections of GWLs 1.5 °C, 2.0 °C, 2.5 °C, and 3.0 °C

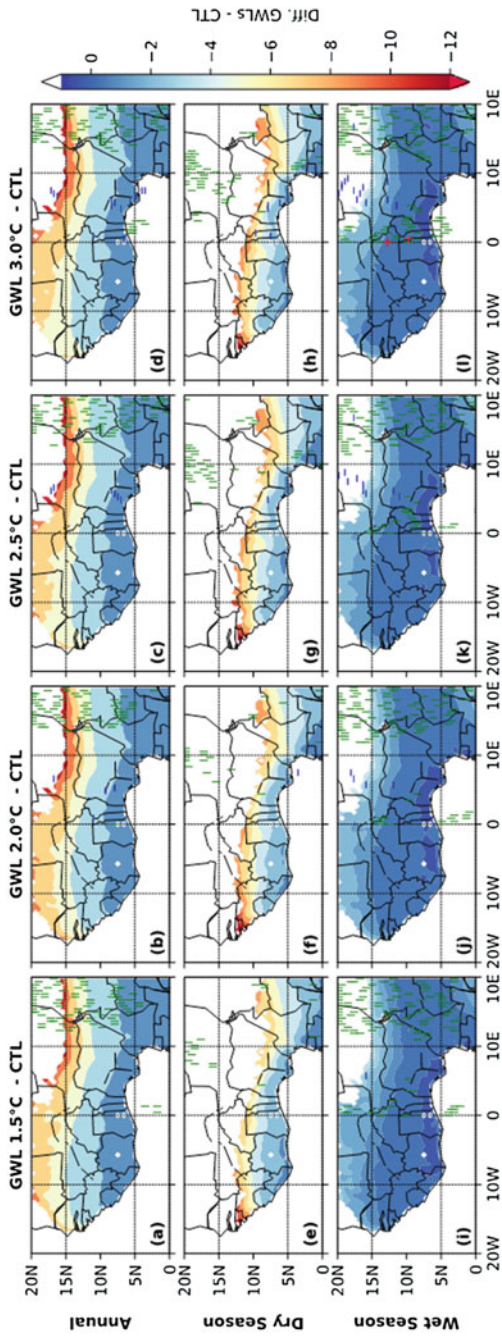
The PCI computed for the seasonal scale over West Africa indicates complex spatial patterns of precipitation distribution. Therefore, Fig. 2f–j shows that precipitation is uniformly distributed (i.e., almost the same amount of precipitation occurs in each month) over the Gulf of Guinea and the Savanna. For the studied GWLs, when compared with the historical period, it can be noticed that the uniform precipitation distribution extends a little toward the Sahel. So, the precipitation concentration is irregularly distributed (i.e.,  $PCI \in [16, 20]$  according to Oliver 1980) over the northern region of West Africa during the rainy season.

Figure 2k–o presents the PCI for the dry season. It illustrates an irregular precipitation concentration distribution over the Gulf of Guinea. This is obvious, because there is almost no rain during this period of the year, and the irregular distribution noticed might be due to some isolate rains recorded after some particular meteorological phenomena. The precipitation in the Savanna and Sahel is strongly irregularly distributed (i.e.,  $PCI > 20$  during the rainy period, according to Oliver 1980), which means that the total of significant precipitation occurs within a short period (1–2 months).

The analysis of simulations presented in Fig. 2 (with regard to annual and seasonal evaluation) establishes that in West Africa, the precipitation is uniformly well distributed during the period May–September (MJJAS) in the Gulf of Guinea and the Savanna. A northward gradient is well noticed because the highest values of the PCI are located in the Sahel, whereas the lowest are identified around the Gulf of Guinea. Despite the global warming effect for all levels, the precipitation concentration does not change over the Gulf of Guinea and the Savanna; on the contrary, it extends toward the northern region of the study domain.

### Evaluation of the Models' Robustness

Figure 3, which presents the differences between the projected PCI in respect of the historical period, shows that the level of variability is similar from one GWL to another. The annual and seasonal concentrations reduce gradually from the Sahel to the Gulf of Guinea, and confirm the variability illustrated by Fig. 2, which shows the regression of irregular and strong irregular precipitation concentrations. Figure 3 also illustrates the robustness of the simulations. At least 80% of models (indicated here with vertical green strips) demonstrate that the precipitation concentration over the eastern part of the study area has changed. This change, which increases according to the GWLs, is also shown over several countries, such as Niger during the rainy season. At least 80% of the models demonstrated that the change is significant (as indicated by the horizontal blue strips), with a confidence level of 95%. Here too, Niger and Nigeria are projected to experience significant changes, which will increase with the GWLs. The red cross (+) is observed in the area where at least 80% of the simulations agree with regard to the change, and where these changes have a 95% confidence level. Therefore, during the rainy season and under GWL3.0, countries such as Ghana, Togo, and Burkina Faso present a more uniform precipitation distribution, in contrast to variabilities for the historical period and the projections (Fig. 2).



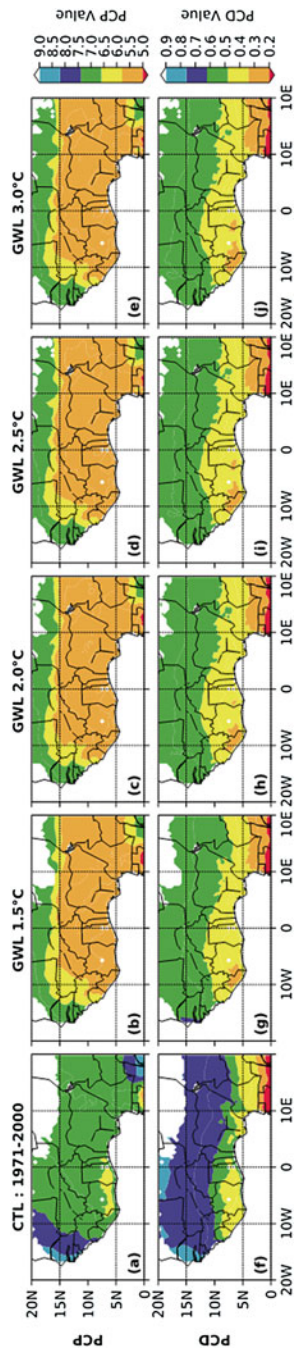
**Fig. 3** Evaluation over West Africa of the difference between the changes at 1.5 °C, 2.0 °C, 2.5 °C, and 3.0 °C GWLs of PCI using the CORDEX Africa ensemble. The vertical green strip (|) indicates where at least 80% of the models agree on the sign of the changes, while horizontal blue strip (-) indicates where at least 80% of the simulations agree that the projected change is statistically significant with 95% as confidence level. The red cross (+) indicates where both conditions are satisfied

## Variability of PCD and PCP

Figure 4 presents the PCP and PCD. Figure 4a–e shows that the variability over the entire West Africa of PCPs both for historical and projected periods is a range between  $7 \pm 2$ . This indicates that the yearly mean precipitation concentration over West Africa occurs between June and September. The analysis corroborates with the current knowledge about the period of the West African precipitation producing system, which is led by the West African Monsoon (WAM). The high values during the control period are observed in the north-western of West Africa, while regarding the projected period, the highest values are recorded over the Sahel. The finding indicates that the wet season starts earlier in the southern regions, followed by the Savanna before reaching the Sahel in the North. The variability of the yearly mean PCDs (shown in Fig. 4f–j) is between 0.17 and 0.90, indicating the high spatial variability of the precipitation concentration in the study domain. When looking at the historical period simulations (Fig. 4f), it can be observed that the computed PCDs increase northwardly. Lower values (0.17–0.60) are located around the Guinea coast, and the highest ( $>0.80$ ) in the Sahel. This denotes the existence of a gradient across the Gulf of Guinea and the Sahel. This gradient informs that precipitation during the rainy season is more concentrated in a few months across the Sahel compared to the Gulf of Guinea. For the projected simulations, the same gradient Gulf-of-Guinea-Sahel is observed, although here the magnitude of the PCD is less in response to the control period. The lower values lie between 0.17 and 0.50, and the higher range between 0.5 and 0.6. During the projected period, there is globally a decrease of precipitation concentration compared to the historical period, leading both the Sahel and the Savanna having the same precipitation distribution for all GWLs studied. Furthermore, the projections indicate a shift in time for the starting of the rainy season. Therefore, comparing the projected and the present period, it is noticed that the wet season will start earlier. The highest concentration of precipitation will occur from May to July for the Gulf of Guinea and the Savanna, and in August for the Sahel.

## Daily Precipitation Variability

The consecutive wet days (CWD) and consecutive dry days (CDD) were calculated over the study domain to evaluate the daily variability of the precipitation distribution. CWD and CDD also indicate extremes in rainfall. CDD is furthermore a useful indicator for studying short-term droughts (Frich et al. 2002) and drought tendencies (Orlowsky and Seneviratne 2012), as it could indicate enhanced dryness and high risk for seasonal droughts (Klutse et al. 2018). Changes in CDD and CWD can lead to uneven temporal distributions of rainfall, which could have a significant consequence for agricultural practices (Barron et al. 2003; FAO et al. 2015; Wiebe et al. 2017). The CDD was calculated both at annual (cdd) and seasonal scales (in this study, May–September: MScdd), in order to evaluate both dry and wet spells within the rainfall season; knowing this is very important for agricultural practices in the region (Klutse



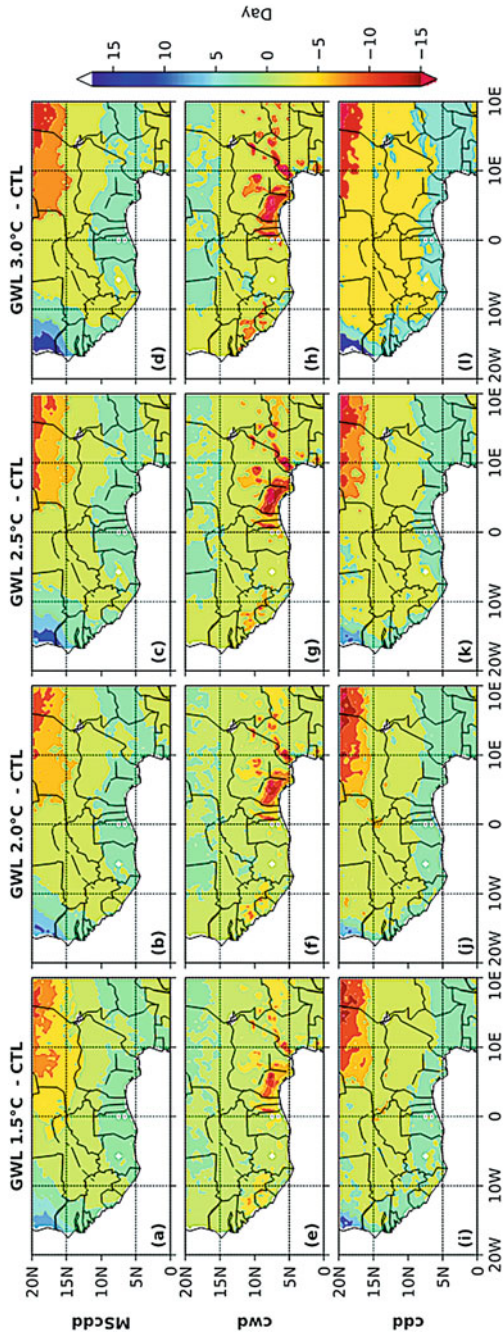
**Fig. 4** Spatial distribution of yearly mean Precipitation Concentration Degree (PCD) and Precipitation Concentration Period (PCP) for the historical period (CTL: 1971–2000) and at projections of GWLs 1.5 °C, 2.0 °C, 2.5 °C, and 3.0 °C



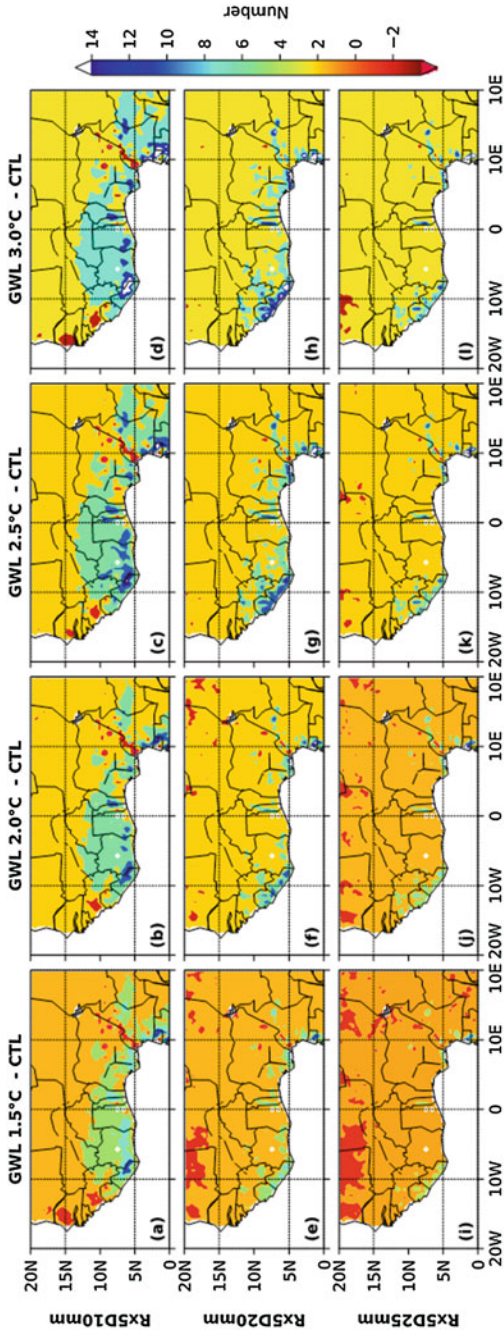
et al. 2018). Figure 5 shows the variability between the projection of different GWLs and the selected historical period. High values of CDD are noticed in the north of West Africa, and higher CWD values around the coast of Gulf of Guinea. The comparison between the results of (Figs. 5a–d, i–l) shows both for annual and rainy season periods a decrease of CDD about  $10 \pm 5$  days over the north-eastern of West Africa. Around the northern area of the study domain, an important variability of dry days is noticed within the rainy season (e.g., a decrease in CDD over the north-eastern part and an increase in CDD over the north-western part), which demonstrates that the north-eastern of West Africa is wetter under GWLs, while the north-western region is drier. Over the Gulf of Guinea, for both annual and rainy season scales a slight variability of CDD for all GWLs is noticed. The results of the GWLs 1.5 °C, 2.0 °C, and 2.5 °C indicate a pattern of CDD with same spatial variability, and for the GWL 3.0 °C (on Fig. 5i), a significant increase in the annual CDD is observed. The CDD is projected to increase for 4–5 days over the Gulf of Guinea; in Mauritania and Senegal, the increase is projected to be  $10 \pm 2$  days as showed by Quenum et al. (2019). Some Sahel countries like Niger and Chad (which are characterized by a dry north-easterly flow crossing the Sahara desert) are projected to record a dwindling of CDD between 10 and 14 days. This finding agrees at GWLs 1.5 °C and 2.0 °C, with Klutse et al. (2018), who showed a reduction for GWLs 1.5 °C and 2.0 °C, in terms of the number of CDD in the wet season over our study domain, and also the results of Sultan and Gaetani (2016), who concluded a decrease in the number of CDD over central Africa.

In contrast to the CDD analysis over West Africa, the CWD did not show important variability. Its variation is very slight and ranges between  $0 \pm 3$  days. Nonetheless, some high variations could be observed at several specific points. On the projected simulations illustrated in Fig. 5e–h), the CWD decreases about  $10 \pm 2$  over the South Benin and Nigeria. A slight augment in CWD of up to 2 days is likely to be noticed in the Sahel.

In order to investigate the spatial variability of extreme rainfall events, which plays an important role in the availability of water resources and agriculture, etc., the frequency of intense rainfall events (RxD10 mm:  $R \geq 10$  mm/day), very intense rainfall events (RxD20 mm:  $R \geq 20$  mm/day), and heavy rainfall events (RxD25 mm:  $R \geq 25$  mm/day) were calculated; they are displayed in Fig. 6. These variables indicate whether there were changes in the amount of precipitation received over consecutive 5 days with the highest precipitation. Figure 6a–d illustrate that, compared to the control period, each GWL detects an increasing RxD10 mm over the orographic regions and the ocean boundary (Gulf of Guinea). There is a very slight increase in the number of RxD10 mm over the Savanna and Sahel zones. In general, the results clearly show that as the GWL increases, the more the projected RxD10 mm increases too (e.g., for GWL 1.5 °C, the increase is about  $7 \pm 2$  over the Gulf of Guinea and  $1 \pm 1$  for the Savanna and Sahel, while for GWL 3.0 °C, the increase is about  $9 \pm 2$  over the Gulf of Guinea and  $3 \pm 1$  for the Savanna and Sahel). In the case of RxD20 mm and RxD25 mm, the general increase in response to increasing GWLs is noticed too. Only the coastal countries record significant increases in RxD20 mm and RxD25 mm, which could be due to the south-westerly moist flow from the Gulf of Guinea inland.



**Fig. 5** Spatial distribution of the change in Consecutive Dry Day (CDD) during the rainy season (MScdd), as well as the annual consecutive dry days (cdd) and the consecutive wet days (cww)



**Fig. 6** Spatial distribution of the change in frequency of intense rainfall events (Rx5D10 mm), very intense rainfall events (Rx5D20 mm), and heavy rainfall events (Rx5D25 mm)

## Adaptation Strategies

Since the spectacular drought events of the 1970s, it has become clear that the high variability in precipitation constitutes one of the major challenges faced by the West African region. Agriculture is one of the major economic activities of West Africa, and thus significant changes in rainfall due to climate change will negatively affect the entire region. These concerns have generated ongoing scientific, social, and political debate. Moreover, some parts of West Africa (mostly along the Guinean Coast) have recorded recurrent flood events since 2000. Thus, both climate variability and increasing trends in droughts and floods and other severe weather events pose a challenge for the primarily rain-fed agriculture systems in West Africa (Sultan and Gaetani 2016). Therefore, any adaptations must enable inhabitants to cope successfully with short-term climate variability as well as to reduce the long-term negative impacts of climate change (Lobell 2014; Saba et al. 2013). Households and communities must become accustomed to and able to respond creatively and effectively to disruptions of their livelihoods. Indeed, in order to be successful, adaptations must be anchored in all processes affecting life. Some of the possible adaptation strategies, especially relating to floods, droughts, and food crops, are illustrated in this study.

According to the results above, at increasing GWLs, precipitation over the Gulf of Guinea and the Savanna will shift and start earlier (in May) and that the highest precipitation concentration will occur in May–June over that area. In addition, intense rainfall events and consecutive wet days will increase in frequency, which can expose the Gulf of Guinea and Savanna to flood events from June onwards. This confirms the results from Donat et al. (2016), which showed that the intensification of the hydrological cycle both in recent decades and in future projections will lead to an increased risk of flooding in dry regions as the climate warms. Groundnut, cassava, and maize are important crops for the Gulf of Guinea, especially for Nigeria, southern Mali, Benin, Ivory Coast, Burkina Faso, Ghana, and Senegal, while over the Savanna, the main crops are yam, millet, and sorghum. Therefore, to inform farmers about short-term coping and adaptation practices, scientists are encouraged to simulate crop models and to assess their uncertainties according to the shift in the times of the projected precipitation distribution and the increase in the soil temperature. Alternative strategies, such as constructing infrastructure or irrigation systems, could also be used to mitigate the impact of exposure.

Regional provisions and strategies that include all West African countries should be developed to meet the challenge of combating GHG production. The framework agreements must link and bind countries to ensure strict compliance with community-based adaptation measures. At the local level, moreover, each country will have to develop precautionary flood and drought warning systems to limit the loss of human life. Scientific community frameworks need to be developed at the local level to improve the seasonal prediction of rainfall models that must be updated frequently in order to generate reliable information. Better research findings are needed to increase knowledge of how information structures could be framed and used to reduce the power of parochial conflicting benefits and overcome inertia, apathy, and lack of political drive. Finally, communication systems geared toward achieving

specific targets (e.g., to assist farmers) will have to be developed. Informing media platforms about climate sciences and adaptation strategy policies and discussions, for instance, would educate the public about the impacts of global warming, the importance of reducing GHG emissions, and the need for developing and implementing mitigation and adaptation strategies.

---

## Discussion and Conclusion

It is widely demonstrated in the literature that West Africa is vulnerable to climate change due to its high climate variability and high reliance on rain-fed agriculture. It does not have an institutional capacity to respond and to adapt climate variability and climate change (Quenum et al. 2019). In order to reduce risks and suggest reliable adaptation strategies for predicted climate change, this study focused on determining the variability of precipitation both in the present time and under various future scenarios. The findings obtained with regard to the PCI showed that in West Africa the period summarizing the main rainfall activity is between May and September. For the historical period, simulations show over the Gulf of Guinea and the Savanna a uniform precipitation distribution, and in the Sahel both moderate and irregular distribution of precipitation. Under future scenarios, i.e., at all the GWLs (1.5 °C, 2.0 °C, 2.5 °C, and 3.0 °C in this study), the magnitude of the simulated PCIs over West Africa reduced and became close to  $PCI < 10$ . This demonstrates that under the selected GWLs, the precipitation concentration of West African becomes more uniformly distributed except for some countries in the north-eastern areas (Niger and Chad), which are least dry at all four GWLs. To get further details on the temporal patterns of the precipitation concentration in the study domain, the PCP variable is computed, which reveals that the magnitude of the PCI increases northwardly materializing a south-north precipitation gradient. The highest precipitation concentrations during the control period occur in July–August and cover the Gulf of Guinea and the Savanna regions, whereas the Sahel records the peaks of its precipitation concentration in September. The PCP too changed in response to increasing GWLs. Therefore, the precipitation for the projected period becomes more concentrated in June–July over the Gulf of Guinea and the Savanna, and in August for the Sahel region. Thus, the rainfall concentration starts one month earlier in the future period compared to the historical (which is very important and needed information for the agricultural sector). Globally, it also noticed that the Savanna-Sahel region recorded a high magnitude of PCD. This means that the total yearly precipitation recorded in this region occurs in a short time, due to the WAM system, which is led by the back-and-forth movement of the Inter-Tropical Discontinuity (ITD) between south and north. Indeed, this movement creates an increased precipitation concentration in the Savanna-Sahel area, which is immediately followed by the southward movement of the ITD. This establishes a long time record of precipitation concentration, which is highlighted by the PCD values over this area. A significant reduction in the CDD is recorded over the north-east (i.e., Niger and Chad), and a slight increase in the number of CWD over the Sahel.

Additionally, based on the results from PCI and PCP, Niger and Chad are projected to experience more wet condition under increasing GWLs. The 5-day cumulative rainfall variable shows that the Gulf of Guinea is projected to experience more intense, very intense, and heavy rainfall events under increasing GWLs. All these results together show how much West Africa will be exposed to higher variability of climate change and also to future heavier rainfall and wet conditions.

To cope with such changes, reduce loss of life, and better manage the impact on inhabitants of this region, some adaptation strategies are necessary under continual climate change. Two types of strategies are required: a regional framework agreement and local coping strategies. The regional agreement is very important because it forces each stakeholder (country) to respect the framework agreement; this is mostly in line with mitigation of climate change at the regional scale. Local strategies are important in two ways: Firstly, local strategies should enable West African countries to respect the regional framework agreement. Secondly, they should encourage countries to look for and develop adequate adaptation possibilities, by responding to the contributions of scientists and decision makers, which represent an important factor in development. They are the ones who have to provide reliable information to the population, and particularly to farmers, for better management of crops in order to ensure food security.

In summary, this study has investigated precipitation variability and change in West Africa under increasing GWLs, and identified an earlier onset of rainfall, especially over the Gulf of Guinea. It has found that the variability of CDDs and CWDs under increasing GWLs is considerable, and that even the intensity of rainfall has increased. Such significant information is useful for farmers and decision makers to ensure the survival and prosperity of the population.

**Acknowledgments** This work was funded by the German Federal Ministry of Education and Research (BMBF) through the West African Science Service Center on Climate Change and Adapted Land Use (WASCAL), which provided a research fund to Gandome Mayeul L.D. Quenum. The Centre for High-Performance Computing (CHPC, South Africa) provided the computing facility used for the study.

---

## References

- Abiodun BJ, Makhanya N, Petja B, Abatan AA, Oguntunde PG (2019) Future projection of droughts over major river basins in Southern Africa at specific global warming levels. *Theor Appl Climatol* 137(3–4):1785–1799. <https://doi.org/10.1007/s00704-018-2693-0>
- Barron J, Rockström J, Gichuki F, Hatibu N (2003) Dry spell analysis and maize yields for two semi-arid locations in east Africa. *Agric For Meteorol*, Elsevier 117:23–37. [https://doi.org/10.1016/S0168-1923\(03\)00037-6](https://doi.org/10.1016/S0168-1923(03)00037-6)
- Chou C, Lan C-W (2011) Changes in the annual range of precipitation under global warming. *J Clim* 25:222–235. <https://doi.org/10.1175/JCLI-D-11-00097.1>
- De Luis M, González-Hidalgo JC, Brunetti M, Longares LA (2011) Precipitation concentration changes in Spain 1946–2005. *Nat Hazards Earth Syst Sci* 11(5):1259–1265. <https://doi.org/10.5194/nhess-11-1259-2011>

- De Perthuis C, Hallegatte S, Lecocq F (2010) *Économie de l'adaptation au changement climatique*. Conseil économique pour le développement durable, Ed, Paris
- Déqué M, Calmanti S, Bössing O, Dell A, Fox C, Haensler A, ... Teichmann C (2017) A multi-model climate response over tropical Africa at + 2°C. *Climate Ser (Elsevier)* 7:87–95. <https://doi.org/10.1016/j.cliser.2016.06.002>
- Diasso U, Abiodun BJ (2015) Drought modes in West Africa and how well CORDEX RCMs simulate them. *Theor Appl Climatol* 128(1–2):223–240. <https://doi.org/10.1007/s00704-015-1705-6>
- Donat MG, Lowry AL, Alexander LV, Gorman PAO, Maher N (2016) More extreme precipitation in the world's dry and wet regions. *Nat Clim Chang* 6(May). <https://doi.org/10.1038/NCLIMATE2941>
- Easterling DR, Meehl GA, Parmesan C, Changnon SA, Karl TR, Mearns LO (2000) Climate extremes: observations, modeling, and impacts. *Sci Compass* 289:2068–2074. <https://doi.org/10.1126/science.289.5487.2068>
- Egbebiyi TS (2016) *Future changes in extreme rainfall events and African easterly waves over west Africa*. University of Cape Town, Cape Town
- Ezenwaji EE, Nzoiwu CP, Chima GN (2017) Analysis of precipitation concentration index (PCI) for Awka Urban area. *Hydrol Current Res* 8(4):4–9. <https://doi.org/10.4172/2157-7587.1000287>
- FAO, IFAD, WFP. (2015) *The state of food insecurity in the world 2015. Meeting the 2015 international hunger targets: taking stock of uneven progress*. (FAO, ed). Rome
- Frich P, Alexander LV, Della-Marta P, Gleason B, Haylock M, Tank Klein AMG, Peterson T (2002) Observed coherent changes in climatic extremes during the second half of the twentieth century. *Clim Res* 19(3):193–212. <https://doi.org/10.3354/cr019193>
- Füssler H-M (2007) Adaptation planning for climate change: concepts, assessment approaches, and key lessons. *Sustain Sci* 2:265–275. <https://doi.org/10.1007/s11625-007-0032-y>
- Gao Y, Zhu X, Yu G, He N, Wang Q, Tian J (2014) Agricultural and forest meteorology water use efficiency threshold for terrestrial ecosystem carbon sequestration in China under afforestation. *Agric For Meteorol* 195–196:32–37. <https://doi.org/10.1016/j.agrformet.2014.04.010>
- Haensler A, Saeed F, Jacob D (2013) Assessing the robustness of projected precipitation changes over central Africa on the basis of a multitude of global and regional climate projections. *Clim Chang* 121:349–363. <https://doi.org/10.1007/s10584-013-0863-8>
- IPCC (2001) *Climate change 2001: synthesis report. A contribution of working groups I, II, and III to the third assessment report of the intergovernmental panel on climate change* (eds: Watson RT, The Core Writing Team). Cambridge University Press, Cambridge/New York
- IPCC (2014) *Climate change 2014: synthesis report. Contribution of working groups I, II and III to the fifth assessment report of the intergovernmental panel on climate change* (eds: Core Writing Team, Pachauri RK, Meyer LA). IPCC, Geneva, p 151
- Klutse NAB, Ajayi V, Gbobaniyi EO, Egbebiyi TS, Kouadio K, Nkrumah F, ... Dosio A (2018) Potential impact of 1.5°C and 2°C global warming on consecutive dry and wet days over West Africa. *Environ Res Lett*. <https://doi.org/10.1088/1748-9326/aab37b>
- Kpadonou RA, Adegbola PY, Tovignan SD (2012) Local knowledge and adaptation to climate change in Ouémé climate change is a major threat to sustainable development in developing countries. According to IPCC (2007), poor communities particularly in sub-Saharan Africa will be most vulnerable because. *Afr Crop Sci J* 20(Supplement S2–20):181–192
- Kumi N, Abiodun BJ (2018) Potential impacts of 1.5°C and 2°C global warming on rainfall onset, cessation and length of rainy season in West Africa. *Environ Res Lett* 13(5):12–13. <https://doi.org/10.1088/1748-9326/aab89e>
- Li X, Jiang F, Li L, Wang G (2011) Spatial and temporal variability of precipitation concentration index, concentration degree and concentration period Xinjiang, China. *Int J Climatol* 31(11):1679–1693. <https://doi.org/10.1002/joc.2181>
- Lobell DB (2014) Climate change adaptation in crop production : beware of illusions. *Glob Food Sec*:1–5. <https://doi.org/10.1016/j.gfs.2014.05.002>

- Locatelli B (2011) Synergies between adaptation and mitigation in a nutshell. CIFOR
- Maure G, Pinto I, Ndebele-Murisa M, Muthige M, Lennard C, Nikulin G, ... Nicholson SE (2018) The southern African climate under 1.5°C and 2°C of global warming as simulated by CORDEX regional climate models. *Environ Res Lett* 13(6):065002. <https://doi.org/10.1088/1748-9326/aab190>
- Moss R, Babiker M, Brinkman S, Calvo E, Carter T, Edmonds J, ... Zurek M (2008) Towards new scenarios for analysis of emissions, climate change, impacts, and response strategies. IPCC expert meeting report. Intergovernmental Panel on Climate Change, Geneva/Noordwijkerhout
- Nikulin G, Jones C, Giorgi F, Asrar G, Büchner M, Cerezo-Mota R, ... Sushama L (2012) Precipitation climatology in an ensemble of CORDEX-Africa regional climate simulations. *J Climate* 25(18):6057–6078. <https://doi.org/10.1175/JCLI-D-11-00375.1>
- Nikulin G, Lennard C, Dosio A, Kjellström E, Chen Y, Hansler A, ... Somot S (2018) The effects of 1.5 and 2 degrees of global warming on Africa in the CORDEX ensemble. *Environ Res Lett* 13(6). <https://doi.org/10.1088/1748-9326/aab1b1>
- Oliver JE (1980) Monthly precipitation distribution: a comparative index. *Prof Geogr* 32(3):300–309. <https://doi.org/10.1111/j.0033-0124.1980.00300.x>
- Orlowsky B, Seneviratne SI (2012) Global changes in extreme events: regional and seasonal dimension. *Clim Chang* 110:669–696. <https://doi.org/10.1007/s10584-011-0122-9>
- Quenum GMLD, Klutse NAB, Dieng D, Laux P, Arnault J, Kodja JD, Oguntunde PG (2019) Identification of potential drought areas in West Africa under climate change and variability. *Earth Syst Environ* 3(3):429–444. <https://doi.org/10.1007/s41748-019-00133-w>
- Rowhani P, Lobell DB, Linderman M, Ramankutty N (2011) Agricultural and forest meteorology climate variability and crop production in Tanzania. *Agric For Meteorol* 151(4):449–460. <https://doi.org/10.1016/j.agrformet.2010.12.002>
- Saba A, Gerrard MB, Lobell DB, Saba A, Biasutti M, Gerrard MB, Lobell DB (2013) Getting ahead of the curve : supporting adaptation to long-term climate change and short-term climate variability alike. CCLR 7. Retrieved from [https://scholarship.law.columbia.edu/faculty\\_scholarship/563](https://scholarship.law.columbia.edu/faculty_scholarship/563)
- Sheffield J, Wood EF, Chaney N, Guan K, Sadri S, Yuan X, ... Ogallo L (2014) A drought monitoring and forecasting system for sub-sahara african water resources and food security. *Am Meteorol Soc* 95(June), 861–882. <https://doi.org/10.1175/BAMS-D-12-00124.1>
- Shi P, Wu M, Qu S, Jiang P, Qiao X, Chen X, ... Zhang Z (2015) Spatial distribution and temporal trends in precipitation concentration indices for the Southwest China. *Water Resour Manag* 29(11):3941–3955. <https://doi.org/10.1007/s11269-015-1038-3>
- Sultan B, Gaetani M (2016) Agriculture in West Africa in the twenty-first century: climate change and impacts scenarios, and potential for adaptation. *Front Plant Sci* 7(August):1–20. <https://doi.org/10.3389/fpls.2016.01262>
- Sylla MB, Gaye AT, Jenkins GS (2012) On the fine-scale topography regulating changes in atmospheric hydrological cycle and extreme rainfall over West Africa in a regional climate model projections. *Int J Geophys* 2012:1. <https://doi.org/10.1155/2012/981649>
- UNFCCC (2010) Framework convention on climate change conference of the parties report of the conference of the parties on its sixteenth session, held in Cancun from 29 November to Part Two: action taken by the conference of the parties at its sixteenth session The Ca, (March), 1–31
- Van Vuuren DP, Edmonds J, Kainuma M, Riahi K, Nakicenovic N, Smith SJ, Rose SK (2011) The representative concentration pathways : an overview. *Clim Chang* 109:5–31. <https://doi.org/10.1007/s10584-011-0148-z>
- Wang X, Zhang J, Yang Z (2013) Historic water consumptions and future management strategies for Haihe River basin of Northern China. *Mitig Adapt Strateg Glob Chang* 20:371. <https://doi.org/10.1007/s11027-013-9496-5>
- Watkiss P, Brown S, Christensen OB, Maule CF, Hinkel J, Jacob D, ... Nicholls R (2015) Effects of 2 C Warming-IMPACT2C modelling results: climate change and sea-level rise from a 2 C climate. *IMPACT2C Policy Brief*, 2, 36



- Wiebe K, Sulser TB, Croz DM, Rosegrant MW (2017) The effects of climate change on agriculture and food security in Africa. International Food Policy Research Institute (IFPRI), Washington, DC
- Zhang L, Qian Y (2003) Annual distribution features of precipitation in china and their interannual variations. *Acta Meteor Sin* 17(2):146
- Zhang Q, Liu CX, Gemmer M, Chen YD, Liu C (2009) Changing properties of precipitation concentration in the Pearl River basin. *China*:377–385. <https://doi.org/10.1007/s00477-008-0225-7>

**Open Access** This chapter is licensed under the terms of the Creative Commons Attribution 4.0 International License (<http://creativecommons.org/licenses/by/4.0/>), which permits use, sharing, adaptation, distribution and reproduction in any medium or format, as long as you give appropriate credit to the original author(s) and the source, provide a link to the Creative Commons license and indicate if changes were made.

The images or other third party material in this chapter are included in the chapter's Creative Commons license, unless indicated otherwise in a credit line to the material. If material is not included in the chapter's Creative Commons license and your intended use is not permitted by statutory regulation or exceeds the permitted use, you will need to obtain permission directly from the copyright holder.





# Socioeconomically Informed Use of Geostatistics to Track Adaptation of Resource-Poor Communities to Climate Change

# 75

Martin Munashe Chari, Hamisai Hamandawana, and Leocadia Zhou

## Contents

Introduction .....	1556
Materials and Methods .....	1558
Study Area .....	1558
Data .....	1560
Methods .....	1560
Presentation of Results .....	1570
Maps That Were Produced from Data on Water Access, Literacy Levels, and Annual Income Levels That Were Used to Assess Adaptive Capacity for Years 2001 and 2011 ...	1572
Tables That Show Adaptive Capacity Levels for Individual Communities by Year Period .....	1574
Discussion and Conclusion .....	1574
Discussion .....	1574
Conclusion .....	1576
References .....	1577

This chapter was previously published non-open access with exclusive rights reserved by the Publisher. It has been changed retrospectively to open access under a CC BY 4.0 license and the copyright holder is “The Author(s)”. For further details, please see the license information at the end of the chapter.

M. M. Chari (✉)

Department of Geography and Environmental Science, University of Fort Hare, Alice, South Africa

Risk and Vulnerability Science Centre (RVSC), University of Fort Hare, Alice, South Africa

e-mail: [martinmchari@gmail.com](mailto:martinmchari@gmail.com)

H. Hamandawana

Department of Geographical Information Systems (GIS) and Remote Sensing, University of Fort Hare, Alice, South Africa

e-mail: [hamandawanah@yahoo.com](mailto:hamandawanah@yahoo.com)

L. Zhou

Risk and Vulnerability Science Centre (RVSC), University of Fort Hare, Alice, South Africa

e-mail: [Lzhou@ufh.ac.za](mailto:Lzhou@ufh.ac.za); [zhouleocadia@gmail.com](mailto:zhouleocadia@gmail.com)

© The Author(s) 2021

W. Leal Filho et al. (eds.), *African Handbook of Climate Change Adaptation*,  
[https://doi.org/10.1007/978-3-030-45106-6\\_122](https://doi.org/10.1007/978-3-030-45106-6_122)

1555

---

**Abstract**

As the Green Climate Fund continues to make concerted efforts to leverage funding for resource-constrained communities in the global south under the aegis of increasing climate change impacts in sub-Saharan Africa, there is urgent and compelling need for tools that assist organizations to track the effectiveness of adaptation interventions in reducing vulnerability. This chapter offers a cost-effective methodology to track adaptation by using a case-study-based identification of communities with diminishing coping capacities in Raymond Mhlaba Local Municipality in the Eastern Cape Province of South Africa. Multistep geostatistical techniques were utilized in the ArcGIS 10.5 software environment to rank and spatialize changes in adaptation by using demographic census data for the years 2001 and 2011. Results of the analysis revealed that 12 communities had declining or static adaptive capacities between 2001 and 2011, while 10 communities had long-term decrease in adaptive capacities from 2001 to 2011 from a sampling universe of 134 communities. These findings are important because they demonstrate that the methodology can be effectively used to provide actionable information on the prevalence of low adaptation capacities at appropriate temporal and spatial scales, in order to guide the allocation of limited resources to the most deserving communities.

---

**Keywords**

Climate change · Adaptation tracking · Geostatistics · South Africa

---

**Introduction**

Africa is one of the most vulnerable continents to climate change (Sarkodie and Strezov 2019; IPCC 2014; World Bank 2014) due to high dependence of livelihoods on climate-sensitive sectors such as agriculture and forestry, poor infrastructure, and limited adaptive capacities to cope with adverse impacts (Ford et al. 2015). In an effort to overcome these constraints, the Paris Agreement and the Katowice Climate Package have been urging all parties to take more climate action by encouraging the adoption and documentation of appropriate adaptation strategies. Adaptation has been getting increasing recognition as a fundamental component of global-level climate change strategies and investigations (Leal Filho and de Freitas 2018; Brooks 2011; Biesbroek et al. 2010), with sub-Saharan Africa emerging in the limelight (Fox et al. 2018; Jiri and Mafongoya 2017; Leal Filho et al. 2015; Leal Filho et al. 2017; Ziervogel et al. 2014; Dinar et al. 2012) because of growing apprehension of climate risks. This apprehension explains why the Green Climate Fund (GCF) has been increasing levels of adaptation funding to many countries in Africa in order to fulfill the Paris Agreement (Pauw et al. 2018; Tompkins et al. 2018; Georgeson et al. 2016) by enhancing their capacities to mitigate the adverse effects of climate change (Mukarakate 2016). This commitment is demonstrated by the recent extension of

support to as many as four climate change adaptation projects in South Africa alone (<https://www.greenclimate.fund/countries/south-africa>). The GCF is part-implementation of the Paris Agreement in the context that “Developed country Parties shall provide financial resources to assist developing country Parties with respect to both mitigation and adaptation in continuation of their existing obligations under the Convention.” Because adaptation funding is increasing, tracking progress in its effectiveness is essential in order to identify constraints that need to be addressed and successes that require further strengthening and improvement.

Adaptation tracking is a part of intervention monitoring and assessment that helps to capture the effectiveness with which coping strategies are translated into tangible courses of action that reduce vulnerability to climate change (Berrang-Ford et al. 2019; Lesnikowski et al. 2017). It is also useful in the governing of adaptation actions by providing a baseline for continuous monitoring and evaluation of progress over time (FAO 2017). Although necessity to monitor the advancement of climate change adaptation is gaining increasing recognition, effective tracking continues to be undermined by lack of objective indicators for scoping how adaptation takes place (Ford et al. 2013). This challenge is aggravated by difficulties in quantifying the expression of adaptation tracking due to lack of reliable tools that can be used to identify trends and gaps in adaptation responses. With climate projections pointing to relatively strong rates of warming over Africa (Engelbrecht et al. 2015) and global temperatures rising by an estimated 1.5 °C above preindustrial levels, it is apparent that there is immediate need to meaningfully embrace climate friendly adaptation strategies (IPCC 2018; New 2018). As atmospheric greenhouse gas concentrations increase in South Africa, an analysis of climate trends, using observations between 1980 and 2016 and IPCC-validated model-simulations up to 2050, projected an increase in global temperatures by 0.02 °C/year up to 2050, and a possible increase to 0.03 °C/year in future (Jury 2019). These scenarios have severe implications for South Africa’s climatically vulnerable communities, and there is convincing evidence to support the view that the need to formulate innovative techniques that can be used to monitor the translation of adaptation plans into implementable interventions is long overdue.

In South Africa, Limpopo and Kwa-Zulu Natal provinces are extremely vulnerable to climate change-related problems due to their high dependence on climate-sensitive sources of livelihood (Rankoana 2019; Hlahla et al. 2018; Ncube et al. 2016; Gbetibouo et al. 2010). Out of the country’s nine provinces, the Eastern Cape is recognized as the most vulnerable (Zhou et al. 2016) because of its susceptibility to consecutive droughts (Ngqakamba 2019; Ndamase 2019; ADM 2010, 2012, 2017; IFRC 2004) with one of the most severe outbreaks being experienced in Amathole District Municipality’s (ADM) Raymond Mhlaba Local Municipality (RMLM) during the 2018/19 season (Ndamase 2019). The severity of this drought is demonstrated by four of the six local municipalities under ADM’s jurisdiction namely: RMLM, Mbhashe, Mnquma, Ngqushwa that received two water trucks each, while the remaining two; namely Great Kei and Amahlathi, received one truck each (Dwesini 2018). Despite the increasing incidence of droughts in RMLM, the implementation of effective climate change adaptation strategies is still ineffective and continues to be undermined by conspicuous absence of reliable adaptation

tracking techniques (ADM 2017). These bottlenecks and challenges justify the need for a methodology that can be used to effectively track adaptation. Although demographic indicators provided in numerical format are useful measures of adaptation (Gamble et al. 2013; van Aalst et al. 2008; Wall and Marzall 2006), they are often inadequately exploited because they require a lot of computational manipulations before they can be translated into spatially intelligible information which can be used to direct attention to areas in need of support (Qiu et al. 2019; de Sherbinin 2016; Schensul et al. 2013).

This limitation is aggravated by the fact that most national-level reports on adaptation tend to present critical information in the form of spatially disjointed metrics that can be used more effectively by presenting them in coherent formats that are capable of directing practitioners to specific target areas when action is required. A structured consolidation of these fragmented regional scale observations into discrete geographical localities is therefore essential and helpful because it provides for bottom-up scientific investigations in which the local informs the regional by facilitating exhaustive interrogation of cause-and-effect relationships and identification of areas where action is needed (Hamandawana et al. 2008). The strength of this approach is demonstrated by the Paris Agreement's adoption of an inclusive agenda on what countries can do with climate change (Conway et al. 2019; Kuwornu 2019) by using grassroots strategies that promote effective implementation of adaptation strategies (Keskitalo and Preston 2019). Mindful appreciation of this inclusiveness is demonstrated by Chari et al. (2018); Bouroncle et al. (2017); Weis et al. (2016); and Juhola and Kruse (2015) who provide useful examples of approaches that can be used to promote adaptation by aiding objective identification of communities that are vulnerable to the adverse effects of climate change.

Although RMLM has not been very successful in attracting support for adaptation initiatives, evidence suggests that local communities in this area are increasingly being exposed to climate-driven short-term variabilities that are considered to be more important stimuli to adaptive responses than long-term changes in climate (Berrang-Ford et al. 2011). Unfortunately, it has not been possible for resource-poor communities in this area and others elsewhere to access meaningful assistance due to lack of local-level information that can be used to delimit localities in need of external support (Taylor 2016). This chapter attempts to demonstrate how this gap can be bridged by providing an adaptable and spatially explicit case-study-based methodology to track the extent to which local communities in RMLM have been able to meaningfully embrace climate-friendly adaptation.

---

## Materials and Methods

### Study Area

Raymond Mhlaba (Fig. 1) is a sparsely populated (~24 people/km<sup>2</sup>) countryside local municipality comprising 23 wards that cover approximately 6,358km<sup>2</sup> (ADM 2017).

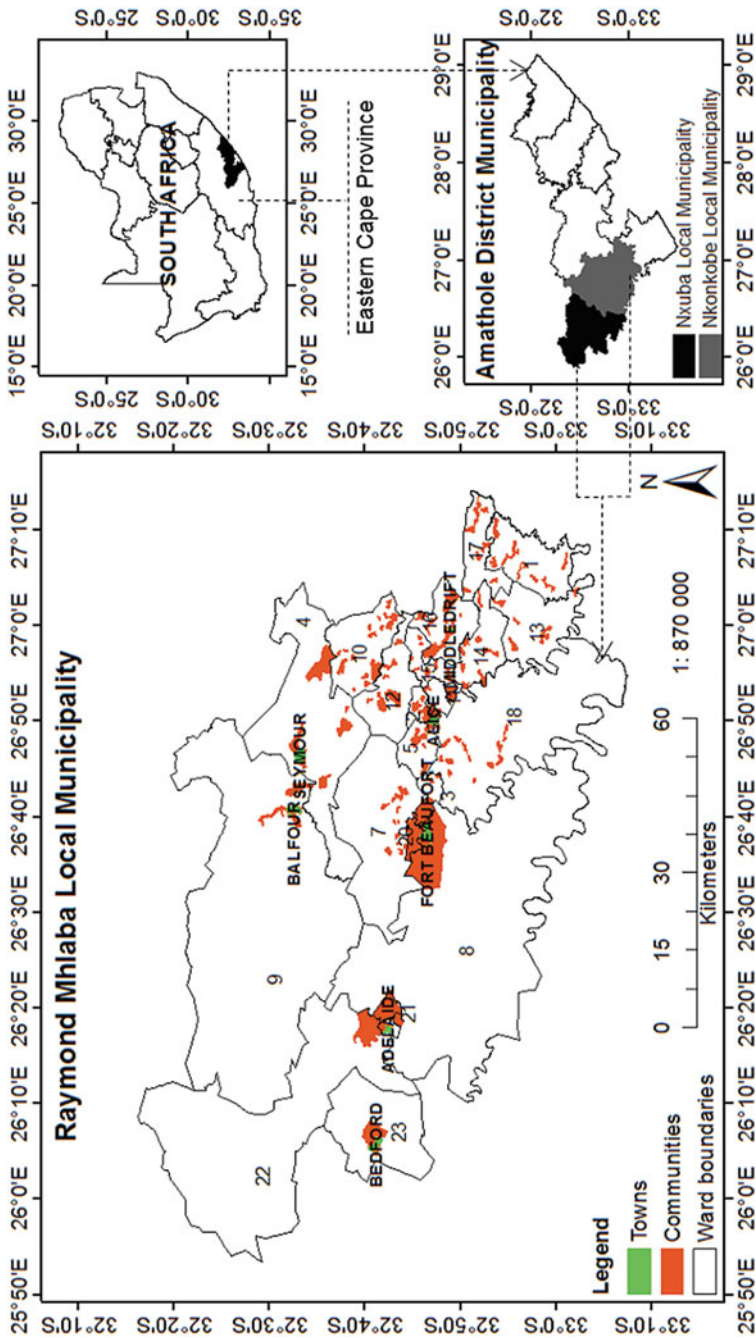


Fig. 1 Location of Raymond Mhlaba Local Municipality. (Source: Chari 2020)

It became the largest of ADM's six local municipalities when it was established by merging Nkonkobe and Nxuba Local Municipalities after the August 2016 local elections (Local Government Handbook 2016). The majority of villages in this area are situated in the immediate peripheries of Fort Beaufort (Fig. 1) with this positioning being largely influenced by accessibility to the latter's urban amenities and availability of arable land for subsistence farming. The entire municipality has a semiarid climate that is characterized by a) unreliable seasonal autumn rainfall which does not exceed 600 mm/annum with the lowest (~7 mm) and highest (~66 mm) amounts occurring in July and March, respectively, and b) average mid-day temperatures that range from 19.3 °C in June to 28.3 °C in January ([www.statssa.gov.za](http://www.statssa.gov.za)). The abilities of this area's local communities to adapt to deteriorating climatic conditions are severely undermined by unreliable rainfall which makes rain-fed subsistence crop production extremely risky. This limitation and the municipality's documented failure to attract substantial adaptation funding and its positioning in a hotspot area with resource-poor households that are projected to experience widespread climate-change induced decrease in crop yields (Ncube et al. 2016) make it a suitable target for a case study-based exploration of novel techniques that can be used to boost adaptation tracking.

## Data

The datasets that were used in this study were compiled by sourcing information from different sources over different time periods between January 2017 and May 2019. These datasets include (a) a shapefile that captures the distributions of local communities in RMLM as compiled by Statistics South Africa (StatsSA) in 2011, (b) 2001 and 2011 census data in a raw Microsoft Excel table format that was provided by the same source, and (c) insights of expert informants that were used to verify the reliability and appropriateness of the municipal-level data that was used in this study. Availability of census data for the years 2001 and 2011 was judged to be timely because these records provided demographic indicators over a 10-year period which was reasoned to be long enough for individual households to translate climate-change-induced coping strategies into quantifiable indicators of adaptation. These datasets were also considered to be reliable because in South Africa, StatsSA is the custodian of official multilevel planning statistics ([www.statssa.gov.za](http://www.statssa.gov.za)).

## Methods

A hybrid approach comprising a multistep GIS-based mapping and analysis of aggregated indicators was used to track the adaptation of resource-poor communities to climate change with adaptive capacity indicators being purposefully selected to accommodate representative inclusion of different communities and the singular geographical and socioeconomic distinctions of their localities. The Nkonkobe Integrated Development Plan (IDP) of 2012–2017 was used to aid the identification

of communities with different livelihood activities because most of the communities in RMLM reside in the former Nkonkobe Local Municipality (Fig. 1). The selection of assessment indicators was based on the definition of adaptive capacity provided by Heltberg and Bonch-Osmolovskiy (2011) and the type and level of demographic data available for the municipality with further refinements being made by using ancillary information that was solicited from expert informants. Overall, the indicators listed and described in Table 1 below were finally selected on the basis of the logic described above and used to assess and map adaptive capacities in the municipality.

Prior to analysis, spreadsheets with information on sub-places/communities were cleaned by (1) deleting unnecessary details from all Excel datasets and (2) selecting matching names in the 2001 and 2011 census records to facilitate the execution of

**Table 1** Description of demographic indicators used for assessing and tracking adaptation

Narrative indicator	Rationale	Ranking/classification of communities
Literacy levels	Specified adaptive capacity within the communities on basis of highest education level. <i>Reclassified from 21 classes to 6 classes.</i>	Scores of 0 to 5 were allocated as follows on the basis of level of education: No schooling = 0, Some Primary = 1, Completed Primary = 2, Some Secondary = 3, Completed Secondary = 4, Higher = 5.
Income levels	Communities with low incomes have low resilience because they are unlikely to have access to credit. <i>Reclassified from 12 classes to 5 classes.</i>	Scores of 0 to 4 were allocated depending on income profiles. Wards with the lowest incomes were allocated a score of 0. Groups were segregated according to annual income as follows: No income = 0, R1 – R9 600 = 1, R9 601 – R19 200 = 2, R19 201 – R38 400 = 3, $\geq$ R38 401 = 4.
Age profiles	Used to identify communities with low resilience to climate change by virtue of being economically inactive due to predominance of children and/ or old people in the population. <i>Reclassified from 18 classes to 4 classes.</i>	Scores of 0 to 3 were allocated and communities segregated into three age groups as follows: 0–14: Child (score of 0), 15–39: Young (score of 2), 40–59: Old (score of 3); *Senior citizen 60+ (score of 1).  <i>* This categorization is based on age criteria used by South Africa Social Security Association (SASSA) to identify beneficiaries of social security assistance</i>
Water access by source type	Specified adaptive capacities of individual communities on the basis of most used water sources. <i>Reclassified from 7 classes to 4 classes.</i>	Other sources = 0, Surface water = 1, Ground water = 2, Regional water scheme = 3.

Source: Adapted from Chari et al. (2018)



valid geospatial analysis operations. To avoid join operation errors in ArcGIS 10.5, all communities that were founded after year 2001 and all extra spaces in the attribute tables of the community names field (key fields) were omitted from the spreadsheet of 2011. Thereafter, shapefiles were created by linking each input indicator's Excel table to the attribute table of the digitized-communities shapefiles and the Join operation used to translate these datasets into spatial layers that were combined with other layers to provide thematic map-portrayals of adaptive capacity ranks. The demographic data from StatsSA was analyzed at community level because this was the lowest level at which required data was available. The combination of layers was followed by turning off repeated fields in the output attribute tables in order to mute field redundancies when the data was exported to the geodatabase. In the final step the following Python script (Script 1) was used to automatically assign scores to communities in the income levels attribute table, and the three indicators (Literacy levels, Source of water, Age profiles) for census years 2001 and 2011 after changing their table names, field names, and row numbers, following the criteria in Table 1.

### Script 1 Script That was Used to Automatically Assign Scores for Community Income Levels

```
##Name of script: Income2001.py
##Purpose: Automated allocation of scores to communities for the
2001 income levels data
#Importing system modules
import arcpy
#Input data and input fields and their lengths
table = "E:/GIS/RayMhlaba.mdb/Income_2001"
fields = ["No_income", "R1_R9600", "R9601_R19200", "R19201_R38400",
"R38401_more"]
#Adding fields to input table to store maximum and field names
maxfield = "HIGHEST"
maxname = "HIGHEST_name"
scores = "In2001_score"
arcpy.AddField_management(table, maxfield, "TEXT")
arcpy.AddField_management(table, maxname, "TEXT")
arcpy.AddField_management(table, scores, "SHORT")
#Adding created fields to the array
fields2 = fields[:] # Shallow copy
fields2.extend([maxfield, maxname, scores])
#Checking and updating of fields
with arcpy.da.UpdateCursor(table, fields2) as cursor:
    for row in cursor:
        arrayVals = [row[0], row[1], row[2], row[3], row[4]]
        highest = max(arrayVals)
        row[5] = highest
        row[6] = fields[arrayVals.index(highest)]
        if row[6] == "No_income":
            row[7] = 0
            cursor.updateRow(row)
        elif row[6] == "R1_R9600":
            row[7] = 1
```

```

        cursor.updateRow(row)
    elif row[6] == "R9601_R19200":
        row[7] = 2
        cursor.updateRow(row)
    elif row[6] == "R19201_R38400":
        row[7] = 3
        cursor.updateRow(row)
    else:
        row[7] = 4
        cursor.updateRow(row)
["No_income", "R1_R9600", "R9601_R19200", "R19201_R38400",
 "R38401_more"]
py.AddField_management(table,maxfield,"TEXT")
py.AddField_management(table,maxname,"TEXT")
AddField_management(table,scores,"SHORT")
extend([maxfield,maxname,scores])
arcpy.da.UpdateCursor(table,fields2) as cursor:
    cursor:
        arrayVals = [row[0],row[1],row[2],row[3],row[4]]
        highest = max(arrayVals)
        row [5] = highest
row[6] = fields[arrayVals.index(highest)]
    if row[6] == "No_income":
        row[7] = 0
cursor.updateRow(row)
    elif row [6] == "R1_R9600":
        row[7] = 1
cursor.updateRow(row)
    elif row [6] == "R9601_R19200":
        row[7] = 2
cursor.updateRow(row)
    elif row[6] == "R19201_R38400":
        row[7] = 3
cursor.updateRow(row)
    else:
        row[7] = 4
cursor.updateRow(row)

```

Script 1 was executed by using the Python `execfile` command to generate a map for each of the four indicators in ArcMap 10.5 for years 2001 and 2011 on the basis of the assigned scores in order to reveal spatial variations in each indicator with communities that had the lowest scores for each indicator being identified by examining all attribute tables. Adaptive capacity scores for both census years (Table 2) were automatically determined by generating a new shapefile and attribute table into which the previously calculated scores from the four indicators for each community were imported and automatically summed up by using Script 2 and Script 3. Although all indicators were weighted equally because of limited availability of indicator data for the municipality, this relaxation did not compromise the reliability of results because information obtained from expert informants and the Nkonkobe IDP for 2012–2017 (Nkonkobe Local Municipality 2012) confirmed that

**Table 2** Evaluation of adaptive capacity in the attribute table for each of the census years

Village	Ward number	Access to water	Literacy levels	Income levels	Age profile	Adaptive score	Adaptive capacity
V <sub>1</sub>	W <sub>1</sub>	3	5	4	3	15	HIGH
V <sub>2</sub>	W <sub>2</sub>	S <sub>1</sub>	S <sub>2</sub>	S <sub>3</sub>	S <sub>4</sub>	.	.
.	.	.	.	.	.	.	.
.	.	.	.	.	.	.	.
V <sub>134</sub>	W <sub>23</sub>	3	3	2	0	8	MEDIUM

V<sub>1</sub>...V<sub>134</sub> – community names; W – ward numbers; S<sub>1</sub>, S<sub>2</sub>, S<sub>3</sub>, S<sub>4</sub> – indicator scores. Adaptive scores ranged from 1–15

Source: Adapted from Chari et al. (2018)

all indicators were equally important for adaptive capacity assessment. Adaptive capacities for the census years 2001 and 2011 were calculated in the attribute table (Table 2) by using the following formula:

$$\text{Adaptive score} = \left( \sum_{n=s1}^{s4} n \right) \quad (1)$$

Where S<sub>1</sub>, S<sub>2</sub>, S<sub>3</sub>, S<sub>4</sub> are scores for each of the four indicators

The following Python script (Script 2) was used to automatically create a new shapefile and attribute table and to join, Age\_Profile scores to the IndicatorScores table. The same script was also used to join the remaining three indicator scores to the IndicatorScores attribute table by using community name as the linking field.

### Script 2 Script That was Used for Automated Creation of a New Shapefile and Attribute Table and Joining of Age\_Profile Scores to the IndicatorScores Table

```
##Name of script: ScoreInput2001.py
##Purpose: Automated creation of a new shapefile and attribute table
for saving an integration of the four indicator scores and
automated joining of the remaining 3 indicator scores to the
IndicatorScores table using MP_NAME as the linking field.
#Importing system modules
import arcpy
from arcpy import env
#Setting the environment
env.workspace = "E:/GIS/"
# Specifying the input feature class, output location and feature
classes
inFeatures = "E:/GIS/RayMhlaba.mdb/Age_2001"
outLocation = "E:/GIS/RayMhlaba.mdb"
outFeatureClass = "Ind_Scores2001"
# Listing fields to be retained
myfields = ["MP_NAME", "A2001_score"]
# Creating an empty field mapping object
mapS = arcpy.FieldMappings()
# Creating an individual field map each field, and adding it to the
field mapping object
for field in myfields:
```

```

map = arcpy.FieldMap()
map.addInputField(inFeatures, field)
mapS.addFieldMap(map)
# Copying the feature class using the fields
arcpy.FeatureClassToFeatureClass_conversion (inFeatures,
outLocation, outFeatureClass, field_mapping=mapS)
#Joining the remaining 3 indicator scores for different fields into
one table
arcpy.JoinField_management("Ind_Scores2001", "MP_NAME",
"Income_2001", "MP_NAME", "In2001_score")
arcpy.JoinField_management("Ind_Scores2001", "MP_NAME",
"Literacy_2001", "MP_NAME", "Lit2001_score")
arcpy.JoinField_management("Ind_Scores2001", "MP_NAME",
"Water_2001", "MP_NAME", "W2001_score")
arcpy import env
#Setting the environment
env.workspace = "E:/GIS/"
# Specifying the input feature class, output location and
feature classes
inFeatures = "E:/GIS/RayMhlaba.mdb/Age_2001"
outLocation = "E:/GIS/RayMhlaba.mdb"
outFeatureClass = "Ind_Scores2001"
# Listing fields to be retained
myfields = ["MP_NAME", "A2001_score"]
# Creating an empty field mapping object
mapS = arcpy.FieldMappings()
# Creating an individual field map each field, and adding it to
the field mapping object
for field in myfields:
map = arcpy.FieldMap()
map.addInputField(inFeatures,field)
mapS.addFieldMap(map)
# Copying the feature class using the fields
arcpy.FeatureClassToFeatureClass_conversion (inFeatures,
outLocation,outFeatureClass,field_mapping=mapS)
#Joining the remaining 3 indicator scores for different fields
into one table
arcpy.JoinField_management
("Ind_Scores2001", "MP_NAME", "Income_2001", "MP_NAME",
"In2001_score")
arcpy.JoinField_management
("Ind_Scores2001", "MP_NAME", "Literacy_2001", "MP_NAME",
"Lit2001_score")
arcpy.JoinField_management
("Ind_Scores2001", "MP_NAME", "Water_2001", "MP_NAME", "W2001_score")

```

Since the highest attainable adaptive capacity score from addition of the four highest indicator scores was 15 (Table 1), the computed adaptive capacity scores were ranked into low-medium-high adaptive capacity as follows: 1–5 = LOW, 6–10 = MEDIUM, and 11–15 = HIGH by using the Python `execfile` command to run the following Python script (Script 3) which automatically added a field for the ranked adaptive capacity scores attribute table.

### Script 3 Script That Was Used for Joining of the Remaining 3 Indicator Scores to the IndicatorsScores Table Using MP\_NAME as the Linking Field

```

## Name of script: AD2001.py
## Purpose: Automated summation and ranking of the four indicator
scores for year ## 2001
#Importing system modules
import arcpy, math
#Importing scores from indicator attribute tables into the Adaptive
capacity shapefile
table = "E:/GIS/RayMhlaba.mdb/Ind_Scores2001"
fields = ["A2001_score", "In2001_score", "Lit2001_score",
"W2001_score"]
# Adding fields to input table to store maximum and field name
total = "AD2001_Score"
rating = "ACRating_2001"
arcpy.AddField_management(table, total, "SHORT")
arcpy.AddField_management(table, rating, "TEXT")
#Adding created fields to the array
fields2 = fields[:]
fields2.extend([total, rating])
#Classifying community-level adaptive capacity scores
with arcpy.da.UpdateCursor(table, fields2) as cursor:
    for row in cursor:
        arrayVals = [row[0], row[1], row[2], row[3]]
#Calculating adaptive capacity for each community by summing the 4
indicator scores
    summation = sum(arrayVals)
    row[4] = summation
    #Allocating the adaptive capacity rating
    if row[4] <=5:
        row[5] = 'LOW'
        cursor.updateRow(row)
    elif row[4] > 5 and row[4] <=10:
        row[5] = 'MEDIUM'
        cursor.updateRow(row)
    else:
        row[5] = 'HIGH'
        cursor.updateRow(row)
## Purpose: Automated summation and ranking of the four
indicator scores for year ## 2001
#Importing system modules
import arcpy, math
#Importing scores from indicator attribute tables into the
Adaptive capacity shapefile
table = "E:/GIS/RayMhlaba.mdb/Ind_Scores2001"
fields = ["A2001_score", "In2001_score", "Lit2001_score",
"W2001_score"]
# Adding fields to input table to store maximum and field name
total = "AD2001_Score"
rating = "ACRating_2001"
arcpy.AddField_management(table, total, "SHORT")
arcpy.AddField_management(table, rating, "TEXT")
#Adding created fields to the array

```

```

fields2 = fields [:]
fields2.extend([total,rating])
#Classifying community-level adaptive capacity scores
with arcpy.da.UpdateCursor(table,fields2) as cursor:
    for row in cursor :
        arrayVals = [row[0],row[1],row[2],row[3]]
        #Calculating adaptive capacity for each community by summing
        the 4 indicator scores
        summation = sum (arrayVals)
        row [4] = summation
        #Allocating the adaptive capacity rating
        if row [4] <=5:
            row [5] = 'LOW'
cursor.updateRow(row)
        elif row [4]>5androw[4]<=10:
            row [5] = 'MEDIUM'
cursor.updateRow(row)
        else: row[5] = 'HIGH'
cursor.updateRow(row)

```

An adaptive capacity map was generated in ArcMap 10.5 from the rankings that were obtained for each of the two census years and the following Python script (Script 4) subsequently used to automatically create a new shapefile and to save adaptive capacities from the indicator scores tables for years 2001 and 2011 in one attribute table (Table 3).

#### Script 4 Script That Was Used for Joining of the Remaining 3 Indicator Scores to the IndicatorsScores Table Using MP\_NAME as the Linking Field

```

## Name of script: AD_Change.py
## Purpose: Automated creation of a new shapefile and saving
adaptive capacities for years 2001 and 2011 into one attribute
table
#Importing system modules
import arcpy
from arcpy import env

```

**Table 3** Evaluation of changes in adaptive capacity scores between census years 2001 and 2011

Village	Ward number	Adaptive score		Difference	Rating
		2011	2001		
V <sub>1</sub>	W <sub>1</sub>	5	8	-3	DECREASE
V <sub>2</sub>	W <sub>2</sub>	A <sub>1</sub>	A <sub>2</sub>	.	-
.	.	.	.	.	.
.	.	.	.	.	.
V <sub>134</sub>	W <sub>23</sub>	12	8	4	INCREASE

V<sub>1</sub>...V<sub>134</sub> – community names; W – ward numbers; A<sub>1</sub>, A<sub>2</sub> – adaptive capacity scores for year 2011 and year 2001, respectively

Source: Chari 2020

```

#Setting the environment
env.workspace = "E:/GIS/"
# Specifying of input feature class, output location and feature
classes
inFeatures = "E:/GIS/RayMhlaba.mdb/Ind_Scores2011"
outLocation = "E:/GIS/RayMhlaba.mdb"
outFeatureClass = "AD_Diff"
# Listing of fields to be retained
myfields = ["MP_NAME", "AD2011_Score"]
# Creating an empty field mapping object
mapS = arcpy.FieldMappings()
# Creating an individual field map for each field and adding it to the
field mapping object
for field in myfields :
    map = arcpy.FieldMap()
    map.addInputField(inFeatures, field)
    mapS.addFieldMap(map)
    # Copying the feature class using the fields
    arcpy.FeatureClassToFeatureClass_conversion(inFeatures,
        outLocation, outFeatureClass, field_mapping=mapS)
#Joining of Adaptive capacity 2001 field to the Adaptive capacity
2011 field to create one table
arcpy.JoinField_management ("AD_Diff", "MP_NAME",
"Ind_Scores2001", "MP_NAME", "AD2001_Score")
    ## for years 2001 and 2011 into one attribute table
    #Importing system modules
    import arcpy
    from arcpy import env
    #Setting the environment
env.workspace = "E:/GIS/"
# Specifying of input feature class, output location and feature
classes
inFeatures = "E:/GIS/RayMhlaba.mdb/Ind_Scores2011"
outLocation = "E:/GIS/RayMhlaba.mdb"
outFeatureClass = "AD_Diff"
# Listing of fields to be retained
myfields = ["MP_NAME", "AD2011_Score"]
# Creating an empty field mapping object
mapS = arcpy.FieldMappings()
# Creating an individual field map for each field and adding it to
the field mapping object
for field in myfields:
    map = arcpy.FieldMap()
    map.addInputField(inFeatures,field)
    mapS.addFieldMap(map)
    # Copying the feature class using the fields
    arcpy.FeatureClassToFeatureClass_conversion(inFeatures,
outLocation,outFeatureClass,field_mapping=mapS)
    #Joining of Adaptive capacity 2001 field to the Adaptive capacity
2011 field to create one table
arcpy.JoinField_management
("AD_Diff", "MP_NAME", "Ind_Scores2001", "MP_NAME", "AD2001_Score")

```

Changes in adaptive capacity scores between census years 2001 and 2011 (Table 3) were calculated by using the following formula:

$$\text{Change in adaptive capacity} = \left( \sum_{n=s1}^{s4} n \right)^{2011} - \left( \sum_{n=s1}^{s4} n \right)^{2001} \quad (2)$$

The adaptive capacity scores were automatically ranked into no change, decrease, and increase as follows: Difference of 0 = NO CHANGE; Difference of  $\leq -1$  = DECREASE; Difference of  $\geq 1$  = INCREASE by using the following Python script (Script 5) that was run by executing the Python `execfile` command which also generated fields for differences and ratings of adaptive capacity scores for the two census years and automatically added them to the attribute table.

### Script 5 Script That Was Used for Calculating Changes in Adaptive Capacities Between 2001 and 2011

```
## Name of script: Diff.py
## Purpose: Calculating changes in adaptive capacities between
years 2001 to 2011
#Importing system modules
import arcpy, math
# Selecting fields of interest from attribute table in shapefile
table = "E:/GIS/RayMhlaba.mdb/AD_Diff"
fields = ["AD2011_Score", "AD2001_Score"]
# Adding new fields to table to store calculated differences in
adaptive capacity
difference = "AC_Resultant"
change = "AC_Change"
arcpy.AddField_management(table, difference, "SHORT")
arcpy.AddField_management(table, change, "TEXT")
#Adding created fields to the array
fields2 = fields[:]
fields2.extend([difference, change])
#Classifying the changes in adaptive capacity
with arcpy.da.UpdateCursor(table, fields2) as cursor:
    for row in cursor:
        arrayVals = [row[0], row[1]]
        #Subtracting the 2001 adaptive capacity from the 2011
        adaptive capacity
        row[2] = row[0] - row[1]
        #Allocating the adaptive capacity change
        if row[2] <= -1:
            row[3] = 'DECREASE'
            cursor.updateRow(row)
        elif row[2] == 0:
            row[3] = 'NO CHANGE'
            cursor.updateRow(row)
        else:
            row[3] = 'INCREASE'
```



```

        cursor.updateRow(row)
        #Importing system modules
import arcpy,math
        # Selecting fields of interest from attribute table in
        shapefile
        table = "E:/GIS/RayMhlaba.mdb/AD_Diff"
fields = ["AD2011_Score","AD2001_Score"]
        # Adding new fields to table to store calculated
        differences in adaptive capacity
        difference = "AC_Resultant"
        change = "AC_Change"
arcpy.AddField_management(table,difference,"SHORT")
arcpy.AddField_management(table,change,"TEXT")
        #Adding created fields to the array
        fields2 = fields[:]
fields2.extend([difference,change])
        #Classifying the changes in adaptive capacity
with arcpy.da.UpdateCursor(table,fields2) as cursor:
        for row in cursor:
            arrayVals = [row[0],row[1]]
            #Subtracting the 2001 adaptive capacity from the 2011
            adaptive capacity
            row [2] =row[0] -row[1]
            #Allocating the adaptive capacity change
            if row [2] <= - 1:
                row [3] = 'DECREASE'
cursor.updateRow(row)
            elif row [2] ==0:
                row [3] = 'NO CHANGE'
cursor.updateRow(row)
            else:
                row [3] = 'INCREASE'
cursor.updateRow(row)

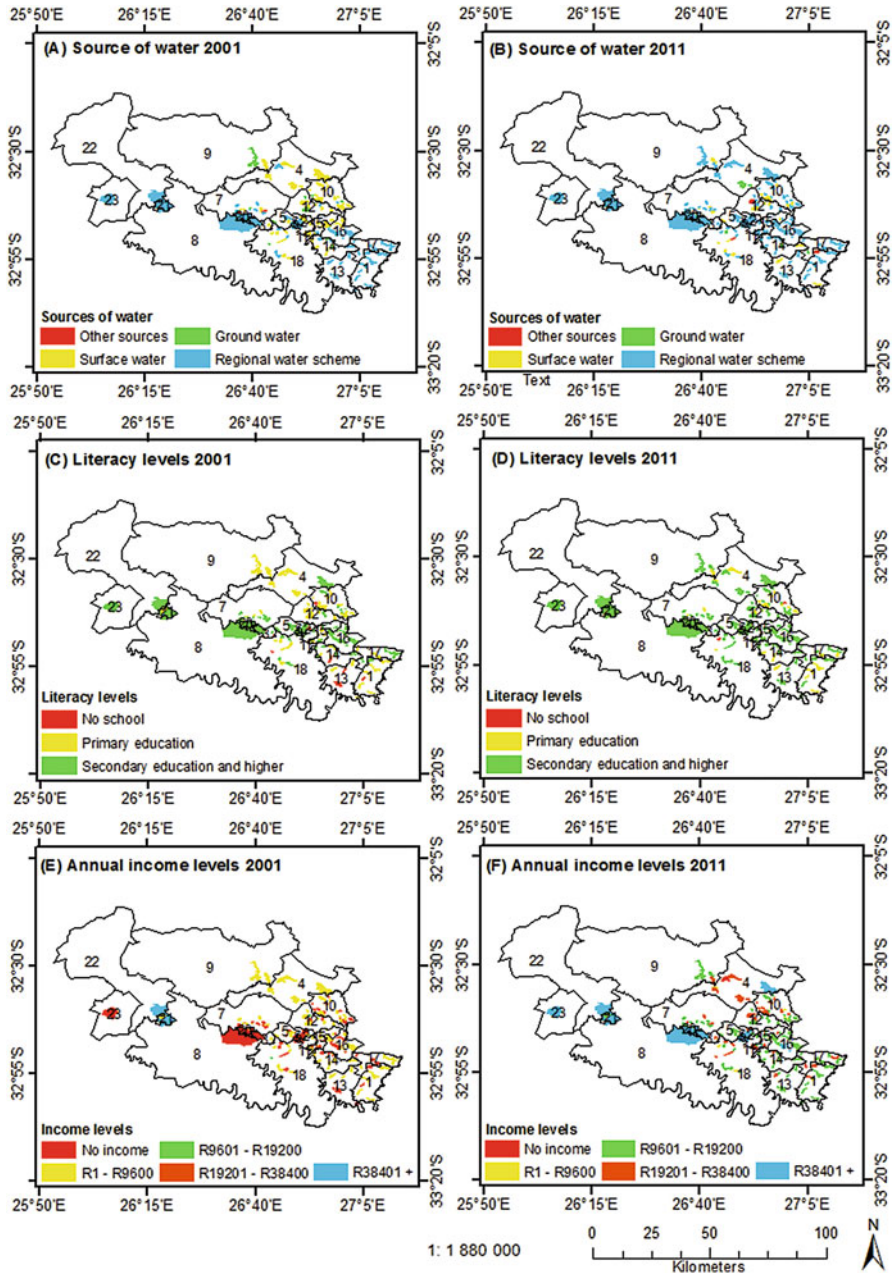
```

A map showing changes in adaptive capacities was produced in ArcMap 10.5 based on the rankings and another map showing communities with low adaptive capacities by year 2011 produced from the 2011 adaptive capacity attribute table. Thereafter, the same attribute table and platform were used to generate a list of communities with decreased adaptive capacities over the 10 years between 2001 and 2011.

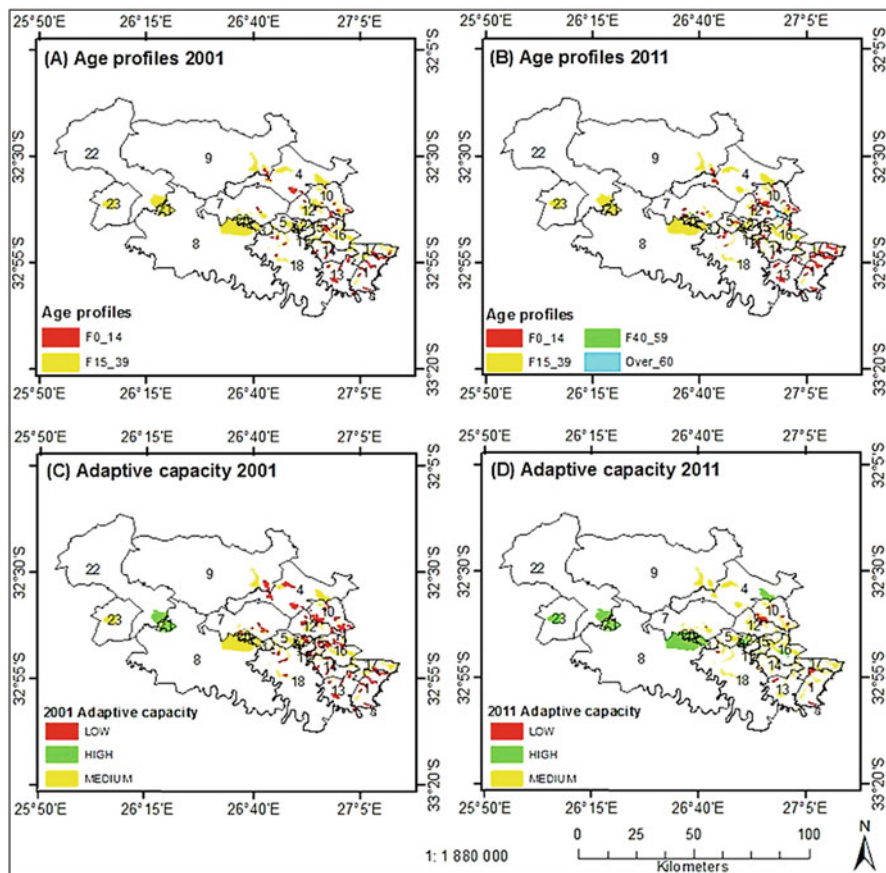
---

## Presentation of Results

Results of this study are presented in the form of (1) maps that were purposefully designed to illustrate how tabulated data can be portrayed in a visually comprehensible manner that facilitates better tracking of adaptation compared to conventional presentation of this important information in the form of tables and histograms that do not capture the spatial dimension (Figs. 2, 3, and 4) and (2) tables that summarize communities that were identified as having declining/static adaptive capacities and



**Fig. 2** Access to water by source type, literacy, and annual income levels for communities in RMLM in 2001 and 2011. (Source: Chari 2020)

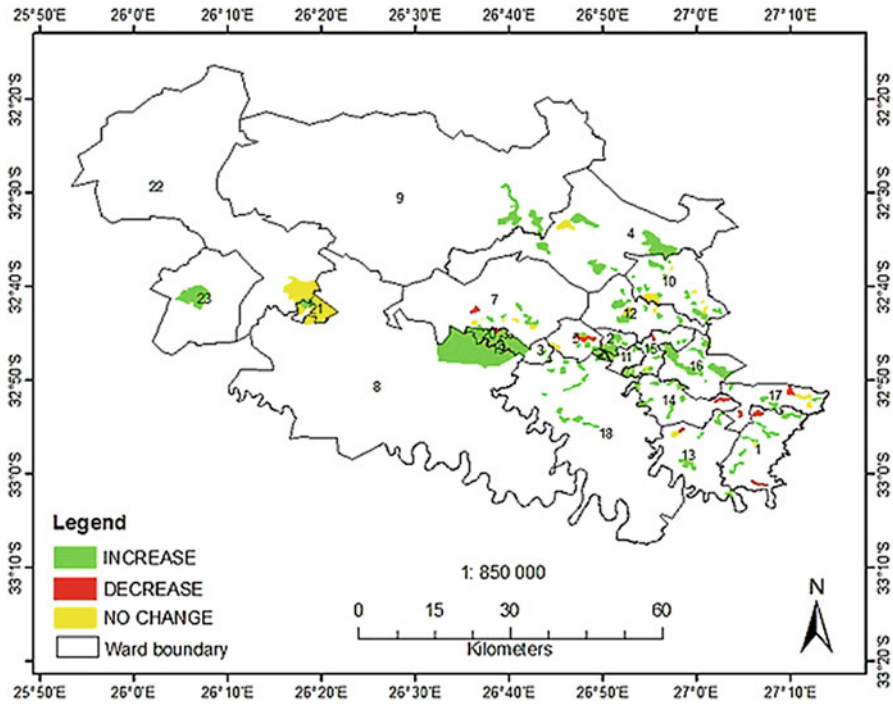


**Fig. 3** Age profiles and adaptive capacities of communities in RMLM in 2001 and 2011. (Source: Chari 2020)

those that were identified as having long-term decrease in adaptive capacities (Tables 4 and 5, respectively).

### Maps That Were Produced from Data on Water Access, Literacy Levels, and Annual Income Levels That Were Used to Assess Adaptive Capacity for Years 2001 and 2011

Figure 2 shows spatial distributions of access to water by source type, literacy levels, and annual incomes that were mapped for individual communities in RMLM on the basis of census data for the years 2001 and 2011. Figure 3 shows age profiles for the same communities and their adaptive capacities on the basis of the three-point scale (LOW-MEDIUM-HIGH) that was used to rank the uptake of adaptation interventions by individual communities. The last map (Fig. 4) shows spatial variations in



**Fig. 4** Changes in adaptive capacities between years 2001 and 2011. (Source: Chari 2020)

**Table 4** Communities that were identified as having a long-term decrease in adaptive capacities from 2001 to 2011

Name of community by number of ward in which it is located	Ward number
MnqabaJames	1
Qamdobowa	1
Mgquba	5
Fernvilla	7
eMgwanisheni	13
Newtown	14
Ncera	15
Koloni	17
Zihlahleni	17
KwaMlalandle	20
N = 10	

Source: Chari 2020

abilities of individual communities to mitigate the adverse effects of climate change by capturing spatial distributions of changes in adaptive capacities that were identified from the ranked adaptive capacity scores in Table 3.

**Table 5** Communities that were identified as having declining/static adaptive capacities in Raymond Mhlaba Local Municipality in 2001 and 2011

Name of community by number of ward in which it is located		Adaptive capacities	
		2001	2011
KwaKulile	1	LOW	LOW
Mnqaba James	1	MEDIUM	LOW
Qamdobowa	1	LOW	LOW
KwaNacelwane	7	LOW	LOW
Jomlo	10	LOW	LOW
Lower Hopefield	10	LOW	LOW
Machibini	10	LOW	LOW
Mdeni B	10	LOW	LOW
Mazotshweni	12	LOW	LOW
eMgwanisheni	13	MEDIUM	LOW
KuDikidikana	13	LOW	LOW
Lebanon	18	LOW	LOW
N = 12			

Source: Chari 2020

## Tables That Show Adaptive Capacity Levels for Individual Communities by Year Period

Tables 4 and 5 show communities that were identified as having (a) declining (medium – low) and static (low) adaptive capacities in the 2001 and 2011 census surveys and (b) communities that were identified as having a long-term decrease in adaptive capacity in the 10 years between 2001 and 2011.

## Discussion and Conclusion

### Discussion

This section discusses the results of this initiative by placing the major findings in a broader context with emphasis being given on the responsiveness of communities to climate change on the basis of the extent to which individual communities were able to access the three indicators that were singled out for investigation and how age profiles influence their adaptive capacities. The section concludes the chapter by stating the methodology's limitations and highlighting its usefulness in tracking adaptation.

### Access to Water

Sources of water by source type in wards 1–23 (Fig. 2a and b) affect the resilience of communities (not shown in Fig. 2a and b) by influencing the availability of water. In 2001 (Fig. 2a), two communities (Teba and KwaNgwevu in ward 7) were severely

water stressed and obtained water from two nonnatural sources comprising water vendors and water tankers. By 2011 (Fig. 2b), three communities (Msobomvu in ward 12, Allandale in ward 13, and MngabaJames in ward 1) were identified as severely water stressed, although they still depended on water from the same nonnatural sources as they did in 2001. The increase in the number of communities depending on nonnatural sources from 2 to 3 is indicative of how deteriorating climatic conditions are reducing natural availability of water which is corroborated by the observed occurrence of consecutive droughts in the Eastern Cape province in 1992, 2004, and 2009 (ADM 2010, 2012; IFRC 2004). These scenarios strongly suggest that in this environment, water scarcity is a persistent problem that requires exploration of alternative water sources and a judicious mix of different water saving techniques in order to reduce dependence on costly supplies provided by government and commercial operators.

### Literacy Levels

Figure 2c and 2d indicates spatial variations in levels of schooling. In 2001 (Fig. 2c), two communities (NgqolowaA and Dhlawu) in ward 13 and six communities (Ndindwa, Gqumashe, KwaMemela, Lower Hopefield, Mavuvumezini, and Calderwood) in wards 1, 2, 3, 10, 14, and 18, respectively, were identified as having no formal schooling. By 2011, only two communities (Mdeni B in ward 5 and Lebanon in ward 13) were identified as having the majority of the population without formal schooling (Fig. 2d). This observation is not only commendable but interesting because it suggests that awareness of climate change issues is increasing as the number of people gaining access to formal education increases. Unfortunately, awareness alone does not automatically translate into increased uptake of actionable adaptation strategies in the absence of enabling factors that facilitate the translation of recommended actions into tangible climate friendly activities because knowing alone without inspiration and capacity to act is inadequate (Adger et al. 2009). Ability to act requires capacity in the form of resources which in the case of RMLM is evidently lacking because of poverty. This asseveration is supported by the 2011 census data which shows that 48.1% of the people in Nkonkobe and 42% in Nxuba were unemployed (StatsSA 2014). In view of this consideration and the documented prevalence of poverty in this area, it is not unreasonable to suggest that although literacy improved, effective implementation of climate change adaptation strategies continues to be constrained by lack of a holistic approach that embraces a wide range of enabling factors that determine the ability of communities to meaningfully embrace climate-friendly interventions.

### Annual Income Levels

Figure 2e and 2f indicate communities with and without income, respectively, with the latter being destined to be susceptible to most climate change-induced shocks due to lack of access to credit. In year 2001, 51 communities emerged as being dominated by people without any income (Fig. 2e) while 5 communities (Seymour, MdeniA, Magxagxeni, Koloni, and kwaSawu) in wards 4, 7, 10, 17, and 15, respectively, were identified as the poorest in the municipality (Fig. 2f). These results

are in agreement with the 2011 census data which shows that the majority of people in these communities do not have any sources of income (StatsSA 2014). The nationwide prevalence of this limitation is supported by many researchers (Mkuhlani et al. 2019; Rusere et al. 2019; Mpandeli and Maponya 2013) who report that in the Lambani, Tshakhuma, Rabali, and Tshiombo communities in Limpopo province, most households find rain-fed crop production extremely risky because they cannot afford supplementary irrigation and do not qualify to get external support in the form of agricultural insurance due to widespread lack of reliable sources of income.

### **Influence of Age Profiles on Resilience**

The identification of communities with different levels of resilience on the basis of age profiles (Fig. 3a and 3b) was based on the reasoning that children and old people have limited capacities to assimilate and implement adaptation strategies by virtue of being economically inactive compared to their economically active counterparts of intermediate age. In year 2001 (Fig. 3a), 37 communities were identified as having the majority of the people in the ages between 0 and 14 years. By year 2011 (Fig. 3b), a total of 46 communities were identified as having the majority of people in the ages between 0 and 14 years with 2 of these communities having the majority of people above 60 years of age while 68 communities had low adaptive capacities in 2001 (Fig. 3c). Although 54 of these communities had improved from low to medium and high adaptive capacities by 2011, this apparent improvement falls short of the desired situation because the downward trend in capacities of two of these communities (eMgwanisheni and MnqabaJames) is actually indicative of the system's inability to effectively mitigate the adverse effects of climate change with additional support for this observation coming from the fact that between 2001 and 2011, ~7.5% of the communities in RMLM were identified as having low or decreasing adaptive capacities (Table 5).

The results presented here are useful because they demonstrate that objectively based geostatistical techniques can be used to aid disaster management by creating space for timely and reliable identification of communities that can be targeted as recipients of appropriately informed adaptation strategies at multiple temporal and spatial scales. In a broader context, the methodology is potentially capable of enhancing adaptation tracking because of its ability to accommodate wide-ranging demographic datasets that are often provided in different and unstandardized formats. This proficiency makes it adaptable to suit different areas of interest and capable of being used to support different stakeholders such as the Global Commission on Adaptation and many others which seek to ensure that adaptation action and support reaches the most vulnerable communities.

---

## **Conclusion**

Although the methodology presented in this chapter is admittedly far from being capable of offering a universal solution due to gaps in the availability of data at appropriate spatial and temporal scales and lack of a single unit of analysis that can

be used to measure or compare adaptation, accessibility of demographic data in most countries still makes it a usable option worth considering because the acquisition of fine-scale data can be prohibitively expensive and time consuming. Even though these challenges are likely to persist for some time into the future, one of the major strengths of the methodology is that it provides an ideal entry point to adaptation tracking at both the national and sub-national levels because its bottom-up basis and firm grounding in a GIS-based framework can accommodate consistent and contextually focused multilevel assessment at different spatial and temporal scales. The other strength of the methodology is that its bottom-up inclination confers a sense of involvement in the decision-making process by creating space for the incorporation of inputs from key stakeholders who are directly involved in and affected by the implementation of adaptation projects. In addition, the methodology's ability to provide a spatially explicit presentation of adaptive capacities offers additional advantages by enabling those interested in adaptation tracking to identify trends in the assimilation and implementation of climate friendly adaptation interventions. The major insight from this initiative is that although data scarcity is often singled out as one of the major constraints confronting adaptation tracking, the geostatistical methodology presented in this chapter provides a workaround approach that can be tapped and used to maximize the utility of different and readily accessible datasets from disparate sources. The take home message is that practitioners, policy-makers, and other stakeholders interested in fast-tracking and enhancing the effectiveness of adaptation interventions stand to benefit by adopting this methodology because it can be easily adapted to effectively track the adoption of adaptation under wide-ranging situations.

**Acknowledgments** The authors would like to thank the Water Research Commission's K5/2496/4 project and National Research Foundation (NRF) of South Africa for funding.

---

## References

- Adger WN, Dessai S, Goulden M, Hulme M, Lorenzoni I, Nelson DR, Naess LO, Wolf J, Wreford A (2009) Are there social limits to adaptation to climate change? *Clim Chang* 93(3):335–354
- ADM (2010) Amathole District Municipality State of the District Address. Amathole Community News, pp 1–2. Available [http://www.amathole.gov.za/old/attachments/article/70/English News-letter 2010 June.pdf](http://www.amathole.gov.za/old/attachments/article/70/English%20News-letter%202010%20June.pdf). Accessed 21 Jan 2019
- ADM (2012) Amathole District Municipality 2012–2017 Integrated Development Plan. Available <http://www.amathole.gov.za/old/attachments/article/324/FINAL%20IDP%202012-2017.pdf>. Accessed 04 Feb 2019
- ADM (2017) Amathole District Municipality 2017–2020 Integrated Development Plan (IDP) – Eastern Cape Socio Economic Consultative Council (ECSECC). Available <https://www.ecsecc.org/information-centre/item/amathole-2017-2020-integrated-development-plan-idp>. Accessed 28 Jan 2019
- Berrang-Ford L, James D, Ford JD, Paterson J (2011) Are we adapting to climate change? *Glob Environ Chang* 21(1):25–33
- Berrang-Ford L, Biesbroek, Ford JD, Lesnikowski A, Tanabe A, Wang FM, Chen C, Hsu A, Hellmann JJ, Pringle P, Grecequet M (2019) Tracking global climate change adaptation among governments. *Nat Clim Chang* 9:440–449



- Biesbroek G, Swart RJ, Carter TR, Cowan C, Henrichs T, Mela H, Morecroft MD, Rey D (2010) Europe adapts to climate change: comparing national adaptation strategies. *Glob Environ Chang* 20(3):440–450
- Bouroncle C, Imbach P, Rodríguez-Sánchez B, Medellín C, Martínez-Valle A, Läderach P (2017) Mapping climate change adaptive capacity and vulnerability of smallholder agricultural livelihoods in Central America: ranking and descriptive approaches to support adaptation strategies. *Clim Chang* 141(1):123–137
- Brooks N (2011) Tracking adaptation and measuring development. IIED climate change working paper: no. 1. IIED, London
- Chari MM (2020) Enhancing adaptive capacities of farmers to climate-induced rainfall variabilities by modelling soil moisture patterns in Raymond Mhlaba Local Municipality, Eastern Cape Province, South Africa. Draft PhD thesis, Department of Geography & Environmental Science, University of Fort Hare, Alice main campus, South Africa
- Chari MM, Hamandawana H, Zhou L (2018) Using geostatistical techniques to map adaptive capacities of resource-poor communities to climate change: a case study of Nkonkobe local municipality, Eastern Cape Province, South Africa. *Int J Clim Change Strategies Manage* 10(5):670–688
- Conway D, Nicholls RJ, Brown S, Tebboth MG, Adger WN, Ahmad B, Biemans H, Crick F, Lutz AF, De Campos RS, Said M (2019) The need for bottom-up assessments of climate risks and adaptation in climate-sensitive regions. *Nat Clim Chang* 9:503–511
- de Sherbinin A (2016) Remote sensing and socioeconomic data integration: lessons from the NASA socioeconomic data and applications center. CRC Press, Boca Raton
- Dinar A, Hassan R, Mendelsohn R, Benhin J (2012) Climate change and agriculture in Africa: impact assessment and adaptation strategies. Routledge. Available <https://content.taylorfrancis.com/books/download?dac=C2011-0-06085-0&isbn=9781136569746&format=googlePreviewPdf>. Accessed 10 Apr 2019
- Dwesini X (2018) ADM secures 10 trucks for drought relief. Daily Dispatch, South Africa. <https://www.dispatchlive.co.za/news/2018-09-18-adm-secures-10-trucks-for-drought-relief/>. Accessed 04 Oct 2019
- Engelbrecht F, Adegoke J, Bopape MJ, Naidoo M, Garland R, Thatcher M, McGregor J, Katzfey J, Werner M, Ichoku C, Gatebe C (2015) Projections of rapidly rising surface temperatures over Africa under low mitigation. *Environ Res Lett* 10(8):85004
- FAO (2017) Tracking adaptation in agricultural sectors: Climate change adaptation indicators. Food and Agriculture Organization of the United Nations (FAO), Rome. Available <http://www.fao.org/resilience/resources/resources-detail/en/c/1106739/>. Accessed 03 April 2019
- Ford J, Berrang-Ford L, Lesnikowski A, Barrera M, Heymann S (2013) How to track adaptation to climate change: a typology of approaches for national-level application. *Ecol Soc* 18(3):40
- Ford JD, Berrang-Ford L, Bunce A, McKay C, Irwin M, Pearce T (2015) The status of climate change adaptation in Africa and Asia. *Reg Environ Chang* 15(5):801–814
- Fox KM, Nelson S, Frankenberger TR, Langworthy M (2018) Climate change adaptation in Ethiopia: developing a method to assess program options. In: Resilience, pp 253–265. <https://doi.org/10.1016/B978-0-12-811891-7.00021-9>. Elsevier
- Gamble JL, Hurlley BJ, Schultz PA, Jaglom WS, Krishnan N, Harris M (2013) Climate change and older Americans: state of the science. *Environ Health Perspect* 121(1):15–22
- Gbetibouo GA, Ringler C, Hassan R (2010) Vulnerability of the South African farming sector to climate change and variability: an indicator approach. *Nat Res Forum* 34(3):175–187
- Georgeson L, Maslin M, Poessinouw M, Howard S (2016) Adaptation responses to climate change differ between global megacities. *Nat Clim Chang* 6(6):584–588
- Hamandawana H, Chanda R, Eckardt F (2008) Reappraisal of contemporary perspectives on climate change in southern Africa's Okavango Delta sub-region. *J Arid Environ* 72(9):1709–1720
- Heltberg R, Bonch-Osmolovskiy M (2011) Mapping vulnerability to climate change. World Bank Policy Research, Washington, DC

- Hlahla S, Nel A, Hill TR (2018) Assessing municipal-level governance responses to climate change in KwaZulu-Natal, South Africa. *J Environ Plan Manag* 62(6):1089–1107  
<https://www.greenclimate.fund/countries/south-africa>. Accessed 17 Apr 2019
- IFRC (International Federation of Red Cross) (2004) South Africa: drought. Available <http://www.ifrc.org/docs/appeals/rpts04/ZA040130.pdf>. Accessed 03 Jan 2019
- IPCC (2014) Climate change 2014: synthesis report. Contribution of Working Groups I, II and III to the fifth assessment report of the Intergovernmental Panel on Climate Change [Core writing team, Pachauri RK, Meyer LA (eds)]. Geneva. Available <https://www.ipcc.ch/report/ar5/syr/>. Accessed 13 Apr 2019
- IPCC (2018) Summary for policymakers. In: Masson-Delmotte V, Zhai P, Pörtner H-O, Roberts D, Skea J, Shukla PR, Pirani A, Moufouma-Okia W, Péan C, Pidcock R, Connors S, Matthews JBR, Chen Y, Zhou X, Gomis MI, Lonnoy E, Maycock MT, Waterfield T (eds) Global warming of 1.5°C. An IPCC Special report on the impacts of global warming of 1.5°C above pre-industrial levels and related global greenhouse gas emission pathways, in the context of strengthening the global response to the threat of climate change, sustainable development, and efforts to eradicate poverty. World Meteorological Organization, Geneva, 32 pp. Available <https://www.ipcc.ch/sr15/chapter/summary-for-policy-makers/>. Accessed 23 Nov 2018
- Jiri O, Mafongoya P (2017) A synthesis of smallholder farmers' adaptation to climate change in Southern Africa: averting adaptation vacuum. In: Climate change adaptation in Africa. Springer, Cham, pp 247–265. [https://doi.org/10.1007/978-3-319-49520-0\\_16](https://doi.org/10.1007/978-3-319-49520-0_16)
- Juhola S, Kruse S (2015) A framework for analysing regional adaptive capacity assessments: challenges for methodology and policy making. *Mitig Adapt Strateg Glob Chang* 20(1):99–120
- Jury MR (2019) South Africa's future climate: trends and projections. In: Knight J, Rogerson CM (eds) The geography of South Africa. Contemporary changes and new directions. World regional geography book series, vol 4. Springer International Publishing AG, a part of Springer Nature, Cham, pp 305–312
- Keskitalo E, Preston B (2019) Research handbook on climate change adaptation policy. Edward Elgar Publishing, Cheltenham/Northampton
- Kuwornu JKM (2019) Climate change and Sub-Saharan Africa: the vulnerability and adaptation of food supply chain actors series on climate change and society. Vernon Press, Wilmington
- Leal Filho W, de Freitas LE (2018) Climate change adaptation in Latin America. Springer, Cham
- Leal Filho W, Esilaba AO, Rao KP, Sridhar G (2015) Adapting African agriculture to climate change. Springer, Berlin, p 233
- Leal Filho W, Simane B, Kalangu J, Wuta M, Munishi P, Musiyiwa K (2017) Climate change adaptation in Africa. *Climate change management*, 1610–2010. Springer, Cham
- Lesnikowski A, Ford J, Biesbroek R, Berrang-Ford L, Maillet M, Araos M, Austin SE (2017) What does the Paris Agreement mean for adaptation? *Clim Pol* 17(7):825–831
- Local Government Handbook (2016) The local government handbook: South Africa. <http://www.localgovernment.co.za/locals/view/233/Raymond-Mhlaba-Local-Municipality>. Accessed 27 Feb 2019
- Mkühlani S, Crespo O, Rusere F, Zhou L, Francis J (2019) Classification of small-scale farmers for improved rainfall variability management in South Africa. *Agroeco Sustain Food Syst* 1–23. <https://doi.org/10.1080/21683565.2018.1537325>
- Mpandeli NS, Maponya PI (2013) Coping with climate variability in Limpopo Province, South Africa. *Peak J Agric Sci* 1:54–64
- Mukarakate D (2016) Global climate finance – will Africa benefit after Paris?. <http://www.africa.undp.org/content/rba/en/home/blog/2016/4/21/Global-Climate-Finance-Will-Africa-Benefit-After-Paris-.html>. Accessed 25 Mar 2019
- Ncube M, Madubula N, Ngwenya H, Zinyengere N, Zhou L, Francis J, Mthunzi T, Olivier C, Madzivhandila T (2016) Climate change, household vulnerability and smart agriculture: the case of two South African provinces. *Jamba J Disaster Risk Stud* 8(2):6–8
- Ndamase M (2019) ADM again declared a drought disaster area. Daily Dispatch, South Africa. <https://www.pressreader.com/south-africa/daily-dispatch/20190710/281522227653276>. Accessed 10 Oct 2019

- New M (2018) What the latest assessment on global warming means for southern Africa. *Quest* 14 (4):12–13
- Ngqakamba S (2019) Gift of Givers aids drought-stricken Amathole municipality with bottled water in truckloads. *News 24, South Africa*. <https://www.news24.com/SouthAfrica/News/gift-of-givers-aids-drought-stricken-amathole-municipality-with-bottled-water-in-truckloads-20190410>. Accessed 06 Oct 2019
- Nkonkobe Local Municipality (2012) Integrated development plan 2012–2017. [http://nkonkobe.gov.za/?q=system/files/filedepot/2/FINAL\\_IDP\\_2012-2017.pdf](http://nkonkobe.gov.za/?q=system/files/filedepot/2/FINAL_IDP_2012-2017.pdf). Accessed 23 Jan 2019
- Pauw WP, Klein RJ, Mbeva K, Dzebo A, Cassanmagnago D, Rudloff A (2018) Beyond headline mitigation numbers: we need more transparent and comparable NDCs to achieve the Paris Agreement on climate change. *Clim Chang* 147:23–29
- Qiu Y, Zhao X, Fan D, Li S (2019) Geospatial disaggregation of population data in supporting SDG assessments: a case study from Deqing County, China. *ISPRS Int J Geo Inf* 8(8):356
- Rankoana SA (2019) Food security under unreliable rainfall: the case study of a rural community in Limpopo Province, South Africa. *J Water Clim Change*. <https://doi.org/10.2166/wcc.2019.109>
- Rusere F, Mkuhlani S, Crespo O, Dicks LV (2019) Developing pathways to improve smallholder agricultural productivity through ecological intensification technologies in semi-arid Limpopo, South Africa. *Afr J Sci Technol Innov Dev* 1–11. <https://doi.org/10.1080/20421338.2018.1550936>
- Sarkodie SA, Strezov V (2019) Economic, social and governance adaptation readiness for mitigation of climate change vulnerability: evidence from 192 countries. *Sci Total Environ* 656:150–164
- Schensul D, Martine G, Guzmán JM (2013) The demography of adaptation to climate change. UNFPA, IIED, and El Colegio de México, New York
- Statistics South Africa (2014) Census 2011 provincial profile: Eastern Cape. Report No. 03-01-71. <http://www.statssa.gov.za/publications/Report-03-01-71/Report-03-01-712011.pdf>. Accessed 20 July 2019
- Taylor A (2016) Institutional inertia in a changing climate. *Int J Clim Change Strategies Manage* 8 (2):194–211
- Tompkins EL, Vincent K, Nicholls RJ, Suckall N (2018) Documenting the state of adaptation for the global stocktake of the Paris Agreement. *Wiley Interdiscip Rev Clim Chang* 9(5):e545
- Van Aalst MK, Cannon T, Burton I (2008) Community level adaptation to climate change: the potential role of participatory community risk assessment. *Glob Environ Chang* 18(1):165–179
- Wall E, Marzall K (2006) Adaptive capacity for climate change in Canadian rural communities. *Local Environ* 11(4):373–397
- Weis SW, Agostini VN, Roth LM, Gilmer B, Schill SR, Knowles JE, Blyther R (2016) Assessing vulnerability: an integrated approach for mapping adaptive capacity, sensitivity, and exposure. *Clim Chang* 136(3):615–629
- World Bank (2014) Turn down the heat: confronting the new climate normal. World Bank Publications, Washington, DC. [www.statssa.gov.za](http://www.statssa.gov.za). Accessed 13 Mar 2019
- Zhou L, Sibanda M, Musemwa L, Ndhleve S (2016) Vulnerability to climate change related disasters in the Eastern Cape Province: an application of the Household Vulnerability Index (HVI). *J Hum Ecol* 56(3):335–353
- Ziervogel G, New M, Archer van Garderen E, Midgley G, Taylor A, Hamann R, Stuart-Hill S, Myers J, Warburton M (2014) Climate change impacts and adaptation in South Africa. *Wiley Interdiscip Rev Clim Chang* 5(5):605–620

**Open Access** This chapter is licensed under the terms of the Creative Commons Attribution 4.0 International License (<http://creativecommons.org/licenses/by/4.0/>), which permits use, sharing, adaptation, distribution and reproduction in any medium or format, as long as you give appropriate credit to the original author(s) and the source, provide a link to the Creative Commons license and indicate if changes were made.

The images or other third party material in this chapter are included in the chapter's Creative Commons license, unless indicated otherwise in a credit line to the material. If material is not included in the chapter's Creative Commons license and your intended use is not permitted by statutory regulation or exceeds the permitted use, you will need to obtain permission directly from the copyright holder.





# Risks of Indoor Overheating in Low-Cost Dwellings on the South African Lowveld

# 76

Newton R. Matandirotya, Dirk P. Cilliers, Roelof P. Burger, Christian Pauw, and Stuart J. Piketh

## Contents

Introduction .....	1584
Materials and Methods .....	1586
Description of the Study Site and Sampled Dwellings .....	1586
Description of Indoor Temperature Monitoring Sensors: ( <i>Thermochron iButton</i> ) .....	1588
Indoor Air Temperature Measurements ( $T_{ai}$ ) .....	1588
Ambient Air Temperature Measurements ( $T_{air}$ ) .....	1589
Data Analysis .....	1589
Results .....	1589
Discussion .....	1595
Study Limitations .....	1597
Conclusion .....	1598
References .....	1598

## Abstract

The South African Lowveld is a region of land that lies between 150 and 2000 m above sea level. In summer the region is characterized by the maximum mean daily ambient temperature of 32 °C. The purpose of the study was to characterize

This chapter was previously published non-open access with exclusive rights reserved by the Publisher. It has been changed retrospectively to open access under a CC BY 4.0 license and the copyright holder is “The Author(s)”. For further details, please see the license information at the end of the chapter.

N. R. Matandirotya (✉) · D. P. Cilliers · R. P. Burger · S. J. Piketh  
Unit for Environmental Sciences and Management, North-West University,  
Potchefstroom, South Africa  
e-mail: [runyamore@gmail.com](mailto:runyamore@gmail.com); [Dirk.Cilliers@nwu.ac.za](mailto:Dirk.Cilliers@nwu.ac.za); [roelof.burger@nwu.ac.za](mailto:roelof.burger@nwu.ac.za); [Stuart.Piketh@nwu.ac.za](mailto:Stuart.Piketh@nwu.ac.za)

C. Pauw  
NOVA Institute, Pretoria, South Africa  
e-mail: [christiaan.pauw@nova.org.za](mailto:christiaan.pauw@nova.org.za)

indoor thermal environments in low-cost residential dwellings during summer seasons as climate is changing. Indoor and ambient air temperature measurements were performed at a 30-min temporal resolution using Thermochron *iButtons* in the settlement of Agincourt. 58 free running low-cost residential dwellings were sampled over the summer seasons of 2016 and 2017. Complementary ambient air temperature data were sourced from the South African Weather Service (SAWS). Data were transformed into hourly means for further analysis. It was found that hourly maximum mean indoor temperatures ranged between 27 °C (daytime) and 23 °C (nighttime) for both living rooms and bedrooms in summer 2016 while in 2017, maximum mean indoor temperatures ranged between 29 °C (daytime) and 26 °C (nighttime) in living rooms and bedrooms. Pearson correlations showed a positive association between indoor and ambient temperatures ranging between  $r = 0.40$  (daytime) and  $r = 0.90$  (nighttime). The association is weak to moderate during daytime because occupants apply other ventilation practices that reduce the relationship between indoor and ambient temperatures. The close association between nighttime ambient and indoor temperature can also be attributed to the effect of urban heat island as nighttime ambient temperature remain elevated; thus, influencing indoor temperatures also remain high. These findings highlight the potential threat posed by a rise in temperatures for low-cost residential dwellings occupants due to climate change. Furthermore, the high level of sensitiveness of dwellings to ambient temperature changes also indicates housing envelopes that have poor thermal resistance to withstand the Lowveld region's harsh extreme heat conditions, especially during summer. The study findings suggest that a potential risk of indoor overheating exists in low-cost dwellings on the South African Lowveld as the frequency and intensity of heat waves rise. There is therefore a need to develop immediate housing adaptation interventions that mitigate against the projected ambient temperature rise for example through thermal insulation retrofits on the existing housing stock and passive housing designs for new housing stock.

---

### Keywords

Low-cost dwellings · Indoor temperatures · Climate change · Indoor human thermal comfort · Thermal discomfort · Residential dwellings · Extreme weather · Adaptation · Overheating

---

## Introduction

Climate change has triggered a rise in external summer air temperature posing a threat to human indoor thermal comfort and health (Mavrogianni et al. 2010) with cities facing a heightened risk of extreme heat from climate change (Araos et al. 2016). On a regional scale temperature rise in sub-Saharan Africa is expected to be higher than global mean temperatures (Webber et al. 2018; Hoegh-Guldberg et al. 2018) as Southern Africa is expected to rise at 2 °C compared to a global mean of

1.5 °C (Hoegh-Guldberg et al. 2018). Incidences of extreme weather events around the world are increasing as a consequence of climate change with projections showing an increase in the number of warm days/nights putting low-income earners at risk of physical health threats (Hoegh-Guldberg et al. 2018). The most severe effects of global warming will be reflected through an increase in the frequency and intensity of extreme events such as heatwaves (IPCC 2007; White-Newsome et al. 2012; Dosio 2016). Low-income earners who live in substandard housing are likely to feel the full wrath of temperature rises as they cannot adapt quickly to climatic change.

According to the Chartered Institution of Building Services Engineers (CIBSE Guide A), sleep impairment can be experienced at temperatures above 24 °C (Mavrogianni et al. 2010). Low-cost residential dwellings that have poor thermal insulation can overheat if exposed to extreme heat. High indoor temperatures also drive energy consumption via the occupants' demand for cooling (Kavgic et al. 2012). Low-cost residential dwellings in South Africa are poorly insulated exposing them to extreme heat effects (Chersich et al. 2018). During hot spells low-cost structures may be 4–5 °C warmer than outdoor temperatures (Chersich et al. 2018). Indoor overheating is a function of dwelling thermal insulation levels as well as ventilation practices of occupants (Mavrogianni et al. 2010). Overheating occurs when the indoor operative temperature is over 3 °C the thermal comfort temperature (Mavrogianni et al. 2010) which the WHO pegged at 24 °C for indoor environments.

Similar studies on summer indoor temperature monitoring include studies by Summerfield et al. (2007) which monitored 29 dwellings in the United Kingdom (UK) during the summer of 2005–2006 and estimated mean indoor temperatures for living rooms to be 19.8 °C and 19.3 °C for bedrooms while Firth and Wright (2008) monitored 224 dwellings in the UK estimating mean living room temperatures at 21.4 °C and bedroom temperature at 21.5 °C. On the other hand, Mavrogianni et al. (2010) monitored 36 dwellings in London during the summer of 2009. Daytime means in living rooms rose above 28 °C in three dwellings out of the total 36 sampled while average indoor temperatures in 53% of living rooms were above indoor thermal comfort temperatures of 25 °C.

The human thermoregulatory mechanism endeavors to maintain a constant core temperature for the body, which commonly requires that the internal heat generated by metabolism be transferred through the skin and lungs to the surrounding environment (Robinson 2000) with the human body temperature being normally maintained at approximately 37 °C by the anterior hypothalamus through thermoregulation (Hifumi et al. 2018). Heat-related illness develops when the pathological effects of heat load cannot be eliminated from the human body (Szekely et al. 2015) manifesting through excessive loss of water which can induce dehydration and salt depletion (Hifumi et al. 2018). In the event of exposure to extreme high indoor temperatures, removal of excess waste from the body is impeded triggering the core temperature to rise and physical health problems can begin (Robinson 2000). Healthy humans have sufficient heat regulatory which cope with increases in temperature up to a particular threshold; however, beyond a certain point the thermoregulatory system can collapse (Kovats and Hajat 2008).

Climate change has the potential to result in more heat-related illnesses as the mean global temperatures rise (White-Newsome et al. 2012). Occupants with pre-existing diseases, children, and the elderly face the greatest risk from extreme indoor heat (Wright et al. 2017). The WHO estimates the global burden of disease from climate change risk factors to have caused 160,000 premature deaths particularly from heatwaves and floods (Myers et al. 2011). The chronically ill, elderly, and children spend considerable time inside dwellings thus making them more vulnerable to indoor heat exposure (Smargiassi et al. 2008; White-Newsome et al. 2012). Past studies show that Southern Africa is expected to be a climate change hotspot (Hoegh-Guldberg et al. 2018). Most experimental indoor temperature monitoring studies have been done in the Global North hence the study sort to fill this knowledge gap on the threat of climate change on indoor thermal environments in Africa. Adaptation techniques are needed immediately for the housing sector to deal with the impacts of extreme heat on indoor environments (Kinnane et al. 2016). The purpose of the study was to characterize summer indoor thermal environments in low-cost housing units on the South African Lowveld. The chapter is structured as follows: section “**Materials and Methods**” describes the materials and methods, section “**Results**” presents results, section “**Discussion**” presents a discussion of the study, while section “**Conclusion**” presents conclusion and plans for future work.

---

## Materials and Methods

This section outlines the materials and methods used during the study. A brief description of the study site is given followed by a highlight of the indoor sensors used to gather indoor and ambient data.

### Description of the Study Site and Sampled Dwellings

Agincourt/Matsavana (24.8279S: 31.2197E) is a low-income residential settlement on the Lowveld valley and is located in the town of Bushbuckridge Local Municipality in Mpumalanga Province (Wittenberg and Collinson 2017). All sampled dwellings in the study were of a detached nature and were constructed as standalone structures. Dwellings selected were constructed from either hollow block or clay standard bricks or standard cement and sand bricks with no wall plastering and no ceilings and were free running without any mechanical indoor temperature mechanisms but rather depend on occupant ventilation behaviors. Figure 1 represents the study site.

Figure 1 shows the settlement of Agincourt located in the Bushbuckridge Local Municipality in the Lowveld region of South Africa.

Figure 2 shows images of sampled dwellings for the study. The majority of dwellings were detached, roofed from iron corrugated iron sheets, none plastered with no ceilings. The left image represents low-cost dwellings, the middle image



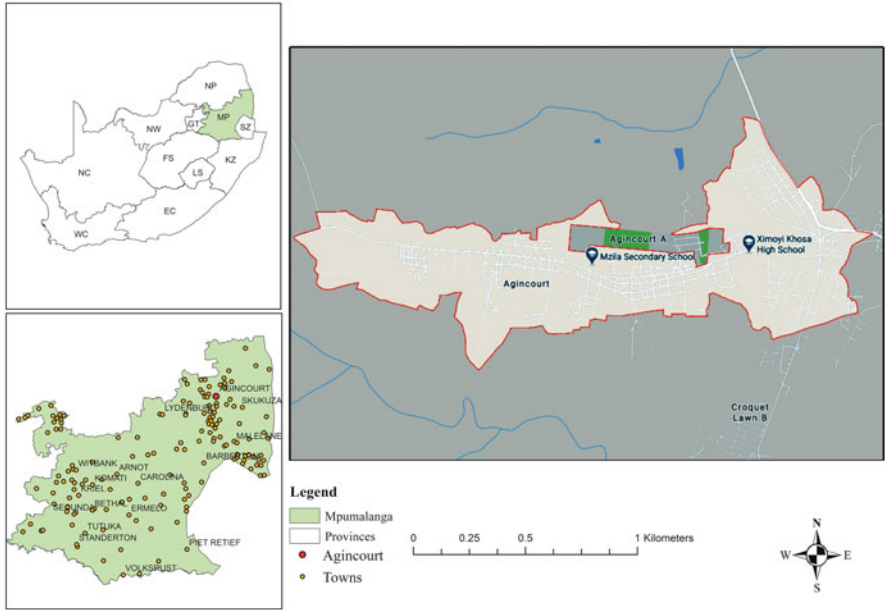


Fig. 1 Agincourt, Mpumalanga Province, South Africa



Fig. 2 Low-cost housing units sampled for the study

shows iButtons hanged inside a dwelling wall, and the right image shows the data downloading process.

### **Description of Indoor Temperature Monitoring Sensors: (Thermochron iButton)**

Indoor air temperatures were measured using Thermochron iButton (DS1922L) manufactured by Maxim Integrated Products formerly Dalls Semiconductor (USA) as shown in Fig. 3. Thermochron iButton has a diameter of 17.35 mm and a thickness of 6 mm (Johnson et al. 2005). These sensors can measure air temperature range of  $-40\text{ }^{\circ}\text{C}$  to  $85\text{ }^{\circ}\text{C}$ . Thermochron loggers are rugged, water-resistant, and self-sufficient sensors that measure temperature and record the result in a protected memory section (Hubbart et al. 2005). Figure 3 shows the image of a Thermochron iButton used in the study.

### **Indoor Air Temperature Measurements ( $T_{ai}$ )**

In each dwelling, two occupied spaces were identified: living rooms and bedrooms with a single sensor (Thermochron iButton) being installed in each room. Living rooms were chosen as this is the space where occupants spend considerable time during the daytime while the bedroom is mostly occupied at night. Air temperature in living rooms space was used as a proxy indicator or for occupant daytime exposure to extreme temperature while the bedroom air temperature was used as a proxy indicator for nighttime extreme indoor temperature exposure. Indoor sensors

**Fig. 3** Thermochron iButton used for indoor and ambient temperature measurement



were placed at a standard height of 1.5 m–1.6 m above ground as applied in Healy and Clinch (2002), Yohanis and Mondol (2010), Newsome et al. (2012), Kane (2013), Lee and Lee (2015) and Magalhaes et al. (2016). Precautions were taken to make sure that sensors were not obstructed by furniture away from direct sunlight, heat, or any form of heat radiation (Malama and Sharpless 1996; Mavrogianni et al. 2010; Loughnan et al. 2015; Lee and Lee 2015; San Miguel-Bellod et al. 2018). Measurements were done continuously over a 24-h cycle at a 30-min temporal resolution.

### Ambient Air Temperature Measurements ( $T_{air}$ )

Ambient air temperature measurements were done using the same sensors as indoor temperatures (Thermochron *i*Button DS1922L). Similar to indoor measurements loggers were set to collect data at a 30-min temporal resolution over a 24-h cycle. Before deployment, all sensors were calibrated and tested for accuracy in the laboratory by the manufacturer (Matandirotya et al. 2019). Supplementary ambient air temperature data were obtained from the South African Weather Service (SAWS) nearest weather station.

Table 1 shows the number of summer indoor monitoring days during the 2016 and 2017 surveys. In 2016 indoor monitoring was done for a total of 17 days while for 2017 monitoring was done for 37 days.

### Data Analysis

The study defined daytime as 8:00 am to 8:00 pm while nighttime was staggered from 9:00 pm to 7 am. For each room, hourly mean temperatures were calculated for the whole monitoring period. To establish the association/relationship between indoor and ambient temperatures at different times of day, indoor and ambient temperature were correlated using simple linear regression. Pearson values were used as a proxy indicator of insulation material strength. Section “Results” presents the results of the study.

---

## Results

This section presents the results of the study. Tables 2 and 3 highlight the descriptive of indoor and ambient temperatures during the indoor monitoring campaigns.

**Table 1** Indoor temperature monitoring times

Study site	From	To	Number of monitoring days
Agincourt 2016	13 April 2016	30 April 2016	17
Agincourt 2017	1 February 2017	9 March 2017	37

**Table 2** Descriptive statistics for summer 2016

	Minimum (°C)	Maximum (°C)	Mean (°C)	Std. Deviation
Ambient daytime	17	38	27	5
Living room daytime ( <i>n</i> = 31)	21	33	27	3
Bedroom daytime ( <i>n</i> = 19)	20	34	27	2
Ambient nighttime	16	26	21	2
Living room nighttime ( <i>n</i> = 31)	20	29	24	2
Bedroom nighttime ( <i>n</i> = 19)	18	28	23	2

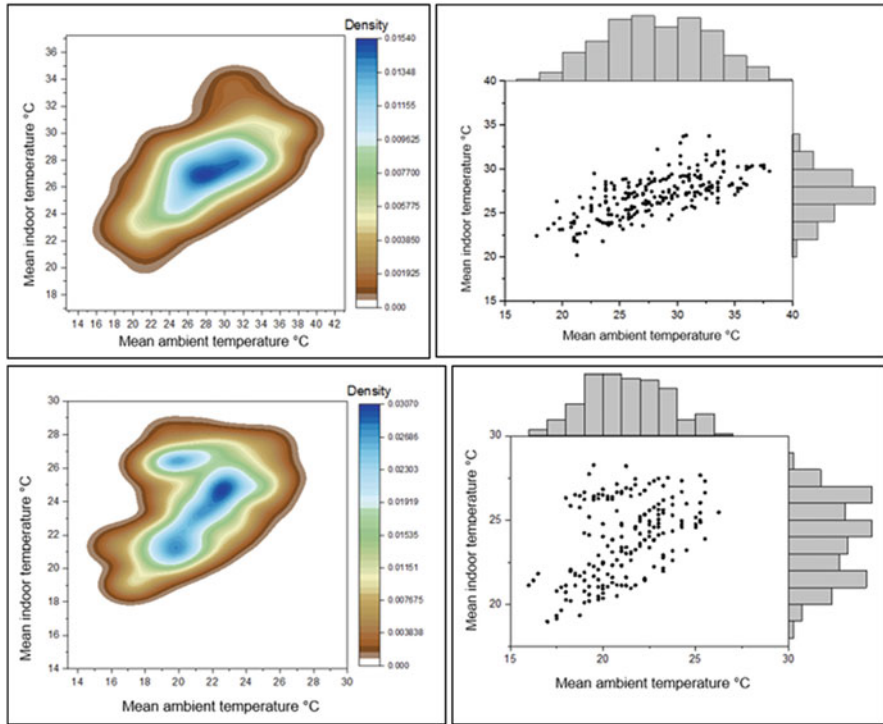
**Table 3** Descriptive statistics for summer 2017

	Minimum (°C)	Maximum (°C)	Mean (°C)	Std. Deviation
Ambient daytime	19	41	29	7
Living room daytime ( <i>n</i> = 27)	21	36	29	4
Bedroom daytime ( <i>n</i> = 27)	21	37	29	4
Ambient nighttime	18	28	22	2
Living room nighttime ( <i>n</i> = 27)	21	33	26	3
Bedroom nighttime ( <i>n</i> = 27)	21	33	26	3

Table 2 represents descriptive statistics of indoor and ambient temperatures during the summer of 2016. The daytime ambient mean was higher than the nighttime mean by 6 °C. The trend was also observed for indoor temperatures during day and nighttime. The occupied spaces bedrooms and living rooms had similar means during daytime at 27 °C, while at nighttime there is 0.6 °C difference between living rooms and bedrooms with living rooms being slightly warmer. Living rooms are occupied spaces during daytimes so there was a potential of thermal discomfort as a result of temperatures exceeding the WHO maximum indoor temperature guideline of 24 °C. During the nighttime, there was also a marginal chance of thermal discomfort as the bedroom temperatures were close to breaching the 24 °C mark.

Table 3 represents descriptive statistics of indoor and ambient temperatures during summer 2017. A similar trend to 2016 was observed as mean daytime ambient temperatures were higher than nighttime temperatures by a 7.4 °C. Occupied spaces (living rooms and bedrooms) showed similar daytime and nighttime behaviors. Daytime differences between bedrooms and living rooms were by 0.2 °C, while at nighttime the difference was by 0.4 °C. There were very marginal differences between the rooms sampled. Figure 4 represents the density distribution of indoor temperatures in bedrooms during the summer of 2016.

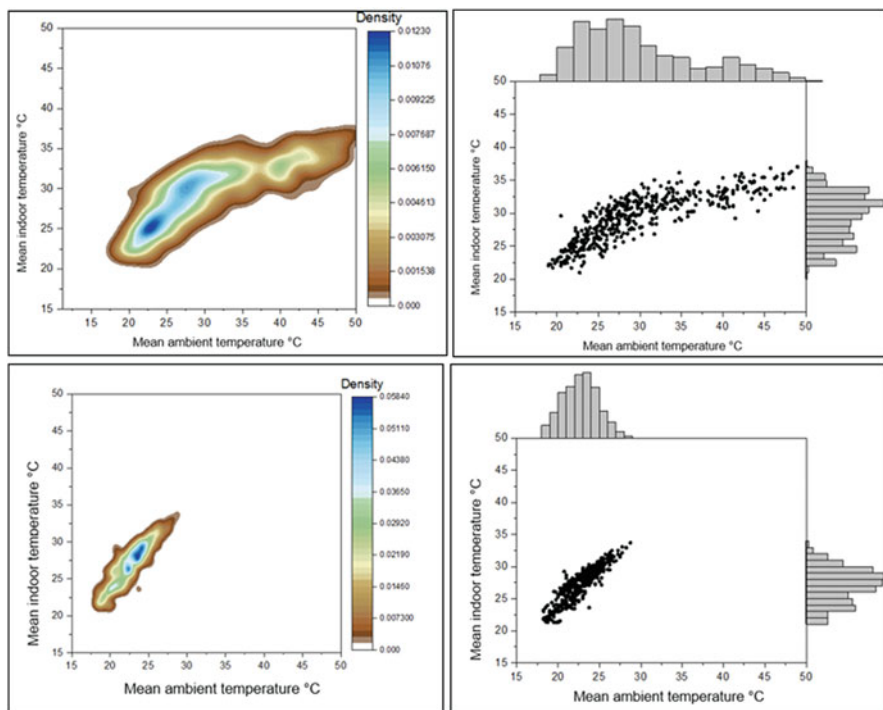
Figure 4 represents indoor temperature density distribution in bedrooms during the summer of 2016. Throughout the summer monitoring period, all bedrooms had median temperatures above 24 °C beyond the WHO maximum temperature



**Fig. 4** Density distribution and marginal histograms of indoor temperatures in bedrooms during the summer of 2016. Top-row represents daytimes while the bottom row represents nighttimes

guideline for thermal discomfort. High bedroom temperature beyond the prescribed 24 °C has the potential to cause sleep impairment especially at night when space is used for night resting. Besides causing sleep impairment high indoor temperatures can cause excessive sweating that ultimately can cause dehydration as well as heat exhaustion. Figure 5 shows the density indoor temperature distribution for bedrooms during the summer of 2017.

Figure 5 shows indoor temperature density in bedrooms during the summer of 2017. During daytimes, indoor temperatures were in the region above 25 °C with minimum hourly mean temperatures being above 20 °C in all bedrooms sampled. The study assumed that this space is not occupied during the daytime; therefore, no risk was anticipated to occupants. According to Fig. 4, temperatures remained high at nighttime with minimum mean nighttime temperature remaining above 20 °C. The high indoor temperatures are mainly from solar radiation absorption which happens during the day which spills over into nighttime since occupants do not have mechanisms to artificially regulate their indoor environments. The impact of these high nighttime indoor temperatures is that occupants are likely to suffer sleep impairment with a potential to loose fluids. With these high ambient temperatures, there is a likelihood of indoor overheating during both daytime and nighttimes.

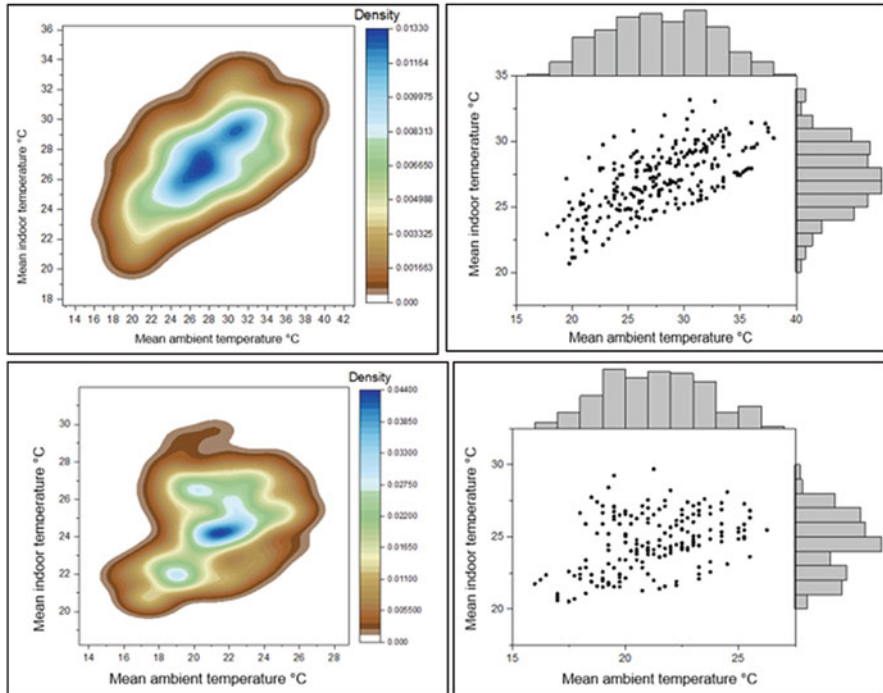


**Fig. 5** Density distribution and marginal histograms of indoor temperatures in bedrooms during the summer of 2017. Top-row represents daytime while the bottom row represents nighttime

Figure 6 shows indoor temperature density distribution in living rooms during the summer of 2016.

Figure 6 shows the density distribution and marginal histograms of indoor temperatures in living rooms during the summer of 2016. The study assumed that living rooms are occupied in space during the daytime. The highest concentration was recorded at mean indoor temperatures of 26 °C during the day, while at night the highest concentration was at 24 °C. The biggest threat to human indoor thermal comfort came from daytime occupation of living rooms as temperatures were at the most time above 24 °C the prescribed thermal comfort temperatures by the WHO. The impact on occupants is that they are likely to lose a lot of bodily fluids from this exposure to high temperatures.

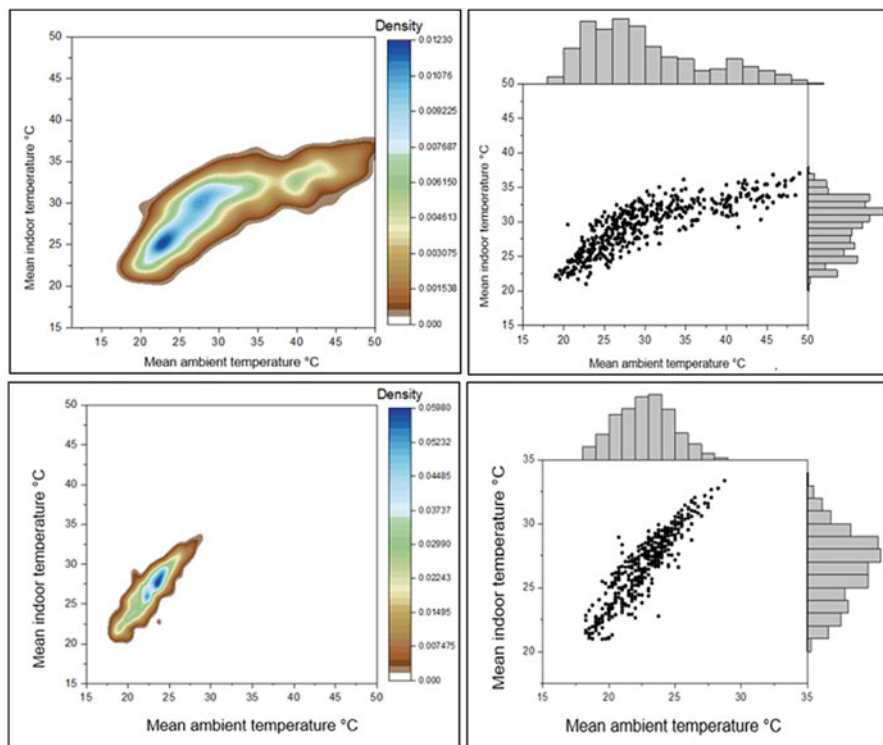
This trend was similar to that observed in bedrooms over the same summer monitoring period. A threat to human thermal comfort can only be experienced in this space during the day as people are expected to be occupying this space while on the other hand if the temperatures breach the 24 °C threshold at night it is a threat to those households that use living space for sleeping purposes thus sleep impairment can happen. Concerning thermal insulation material, the high indoor temperatures



**Fig. 6** Density distribution and marginal histograms of indoor temperatures in living rooms during the summer of 2016. Top row represents daytime while the bottom row represents nighttime

indicate that the thermal material is of poor thermal capacity. Figure 7 shows indoor temperature density distribution in living rooms during the summer of 2017.

Figure 7 shows the density distribution of indoor temperatures during the day and nighttime. A similar trend was observed as in the summer of 2016 where the daytime minimum mean temperatures were recorded at above 20 °C while at nighttime they remained high with the minimum mean recorded in living rooms being at 21 °C. The impact on occupants was expected during the daytime as the study expected occupants to be occupying this space. Negative thermal effects are expected in living rooms if the indoor temperatures are above 24 °C during the day as people are expected to be occupying this space while it can have negative thermal impacts if occupants use this space for sleeping purposes during the night. The high indoor temperatures show that the thermal material used is weak in comparison to the high ambient temperatures experienced in the region thereby exposing occupants to extremely high indoor temperatures. It, therefore, implies that dwellings need to be constructed from a thermal material with the appropriate R-value and resistance capability to withstand the high levels of solar radiation. Measuring R-values of the building material was beyond the scope of this thesis but can be a future line of



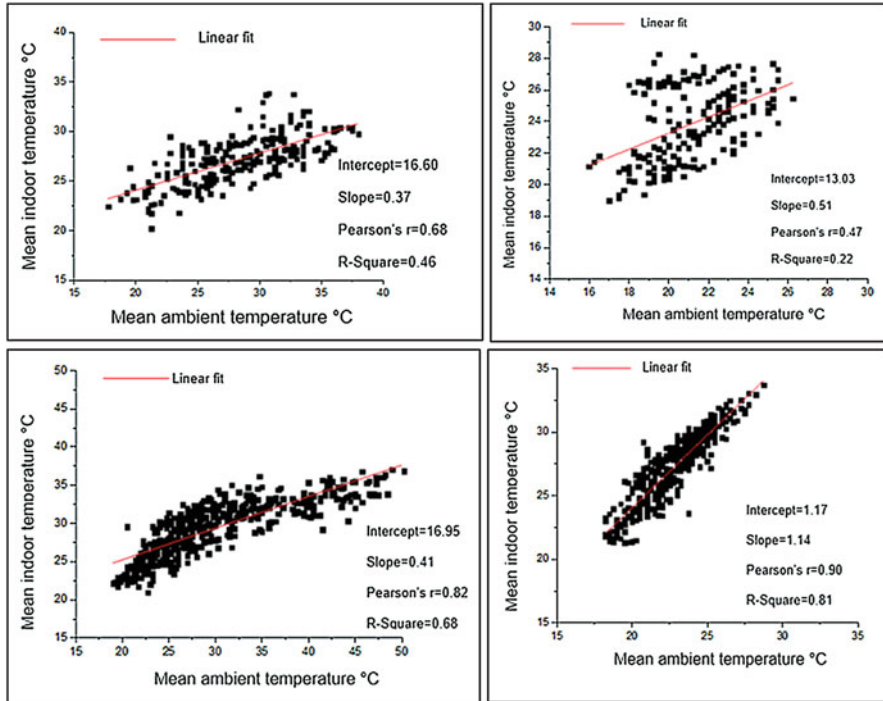
**Fig. 7** Density distribution of indoor temperatures and marginal histograms in living rooms over the summer 2017 monitoring period. Top-row represents daytimes while the bottom row represents nighttimes

research. Figure 8 shows simple linear regression results for mean indoor and ambient temperatures in bedrooms during the summers of 2016 and 2017.

Figure 8 shows the simple linear regression results in bedrooms during the 2016 and 2017 indoor monitoring surveys. During both surveys, ambient temperatures were a good predictor of indoor temperatures with the strongest association being observed during the nighttime of 2017 monitoring ( $r = 0.90$ ), while the least association was observed during nighttime of 2016 ( $r = 0.47$ ). The strong relationship between ambient air temperatures and indoor temperatures shows the weakness in the thermal fabric of the material used to construct the sampled dwellings. Figure 9 shows simple linear regression results for mean indoor and ambient temperatures in living rooms during the summers of 2016 and 2017.

Figure 9 shows simple linear regression results of mean indoor and ambient temperatures in living rooms. The strongest association was observed during the night of 2017 monitoring ( $r = 0.90$ ) while the least association was observed during nighttimes of 2016 at  $r = 0.40$ . The strong relationship indicates that these low-cost dwellings are highly sensitive to ambient temperature changes.

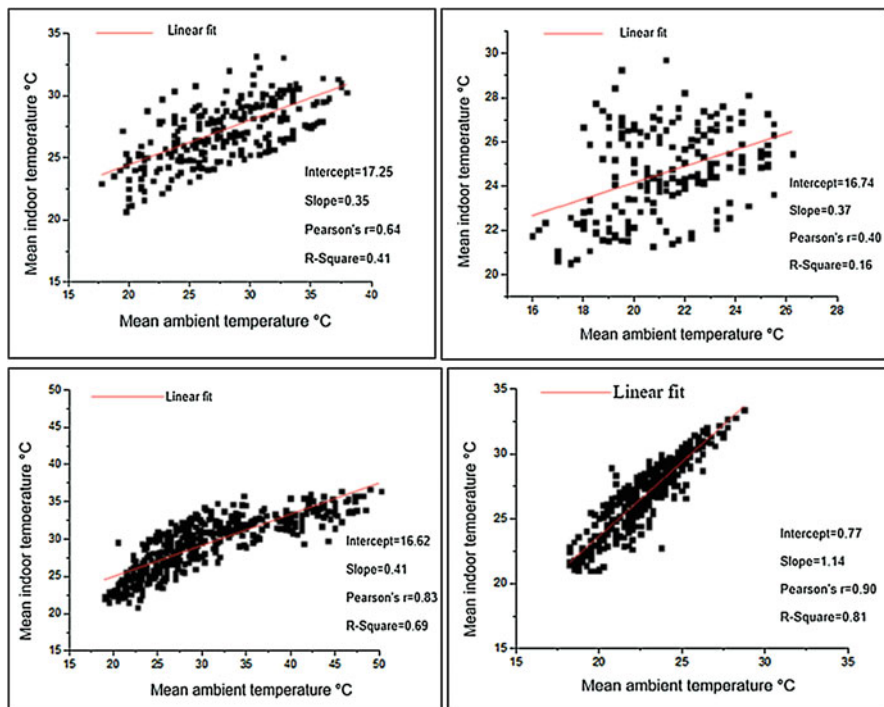




**Fig. 8** Regression results for mean indoor and ambient temperatures in bedrooms. Top-row represents bedrooms 2016, while the bottom row represents 2017. The left image represents daytime while right image represents nighttime

## Discussion

During summer 2016, the study observed that 100% of bedrooms had mean daytime temperatures above 24 °C through the monitoring period, while 53% of the same bedrooms recorded night temperatures exceeding 24 °C. In 2017, during both daytime and nighttime, 100% of bedrooms had daytime mean temperatures above 24 °C. The implication of being exposed to such indoor temperatures for a long time is that occupants lose a lot of fluids that can lead to dehydration. At night sleep impairment can also be experienced due to the high indoor temperatures. The population likely to be negatively affected most are young children and the elderly. Young children suffer from high heat exposure because their thermoregulatory system will not have developed much while for the elderly the thermoregulation system starts to suffer from dysfunction as sweating glands get blocked with aging hence not much sweat is generated to cool off the body. In both instances, it results in heat build-up within the body thereby putting a strain on the core. A strained core can end with such heat-related negative illnesses such as heat strokes, heat cramps, or heat exhaustion (Myers et al. 2011).



**Fig. 9** Regression results of mean indoor and ambient temperatures in living rooms. The top row represents living rooms during 2016 while the bottom row represents living rooms 2017. The left image represents daytime, while right image represents nighttime during summer 2017

A similar trend to bedroom indoor temperature variations was observed in living rooms wherein 100% of living rooms in 2016 breached the 24 °C threshold, while at night 87% of sampled dwellings had mean temperatures above 24 °C. In 2017, the study observed that 100% of living rooms had mean daytime and nighttime indoor temperatures above 24 °C providing ideal conditions for indoor overheating. The high indoor temperatures recorded by the study during 2017 can be attributed to the monitoring period wherein temperature monitoring was done during the peak of summer season in February unlike the 2016 survey where temperature monitoring was done in April which is towards the period of transition to winter on the South African Lowveld. For living rooms, the study anticipated the greatest threat to indoor thermal comfort during daytime as people are occupying this space unlike at night where occupants shift to bedrooms. Prolonged exposure to high indoor temperatures can have devastating effects on those occupants already having underlying health conditions which can worsen.

The study also established that the sampled structures were highly sensitive to ambient temperature changes as confirmed by the strong positive Pearson correlations between indoor and ambient temperatures. The sensitiveness was observed for both day and nighttimes. This confirms that the thermal fabric of sampled dwellings

is weak with an inability to regulate indoor temperatures as desired. If the thermal insulation is fully functional, it could act as a barrier to incoming solar radiation during the day and also be complemented by various ventilation practices put in place by occupants. Since the dwellings sampled were free running, occupants had no opportunity to artificially regulate indoor thermal environments. An increase in heat weather events in South Africa is likely to increase exposure to elevated temperatures for the poor which can be classified as a climate-related health threat (Wright et al. 2017). With ambient temperatures expected to continue on an upward trajectory as a result of climate change, there is a need to improve the thermal fabric of low-cost dwellings which can be achieved through thermal insulation retrofits for existing housing stock while for a new housing stock passive designs can be integrated. These two adaptation strategies can be of help to regulate indoor thermal conditions. The study findings concur to studies by Makaka and Meyer (2005), Naicker et al. (2017), Matandirotya et al. (2019) which also estimated that low-cost dwellings are sensitive to ambient temperature changes because of poor insulation. In a study by Mavrogianni et al. (2010), 53% of livingrooms average indoor temperatures were above thermal comfort levels of 24 °C while 86% of recorded temperatures could result in sleep impairment. Residents of low-cost dwellings are therefore at risk of being exposed to indoor thermal discomfort as temperatures continue to rise as a consequence of climate change.

Extreme high indoor temperature as a result of climate change is bringing several challenges for the built environment as people spend considerable time indoors; hence, the effects are likely to belong-lasting if appropriate adaptation interventions are not introduced especially for the poor marginalized populations who already occupy substandard housing. The study, therefore, brings to the fore the current existing indoor thermal environments in low-cost housing in the context of climate change. One of the possible immediate mitigation measures includes thermal insulation retrofits for the existing housing stock while for new housing stock passive designs can be incorporated. These measures improve the ability of housing structures to regulate indoor thermal environments. Furthermore, greening programs, urban planning, and housing are also other strategies that can be used to mitigate against devastating health threats from climate change (Wright et al. 2017). Future work will focus on measuring the thermal resistance capacity of building materials used for the construction of low-cost dwellings on the South Africa Lowveld region.

## Study Limitations

The study had single sensors deployed in each room during monitoring; therefore, there was no mechanism to account for indoor vertical and horizontal temperature gradients. To mitigate this limitation, the study had to position sensors at the center of rooms where possible without interfering with occupants' daily activities. The study also could not take into account other indoor sources of radiant heat or ventilation practices that could impact on indoor temperatures. Additionally, the other limitation was that the study could not measure humidity which could

facilitated the calculation of apparent temperatures which is an indicator of thermal sensation. Future studies will take into account these factors.

---

## Conclusion

The study estimated that there is a risk of indoor overheating in low-cost dwellings on the South African Lowveld as a consequence of poorly insulated dwellings and a rise in temperatures from climate change. Occupants were exposed to indoor temperatures which breached the WHO maximum thermal guideline of 24 °C subjecting occupants to various physical health threats in the event of prolonged exposure. It is therefore imperative that adaptation and mitigation strategies on the existing housing stock are applied in order to reduce the effects of climate change on occupants. Future work will focus on community participation in the development of housing designs that are climate resilient and suit the changing climatic conditions of Southern Africa.

**Acknowledgments** Acknowledgments go to Brigitte Language who did data collection for the study working under the Prospective Household Observational cohort study of Influenza, Respiratory Syncytial Virus and other respiratory pathogens community burden and Transmission dynamics in South Africa (The PHIRST Study) supported by a grant from the United States Centre for Disease Control and Prevention and conducted by the National Institute for Communicable Disease of the National Health Laboratory Service. Ethical approval for the PHIRST study was obtained from the University of Witwatersrand, Johannesburg HREC (150808). Acknowledgments are also extended to South Weather Service for the provision of ambient temperature data.

---

## References

- Araos M, Berrang-Ford L, Ford JD, Austin SE, Biesbroek R, Lesnikowski A (2016) Climate change adaptation planning in large cities: a systematic global assessment. *Environ Sci Pol* 66:375–382. <https://doi.org/10.1016/j.envsci.2016.06.009>
- Chersich MF, Wright CY, Venter F, Rees H, Scorgie F, Erasmus B (2018) Impacts of climate change on health and wellbeing in South Africa. *Int J Environ Res Public Health*. <https://doi.org/10.3390/ijerph15091884>
- Dosio A (2016) Projection of temperature and heat waves for Africa with an ensemble of CORDEX regional climate models. <https://doi.org/10.1007/s00382-016-3355-5>
- Firth SK, Wright AJ (2008) Investigating the thermal characteristics of English dwellings: summer temperatures: proceedings of conference: air conditioning and the low carbon cooling challenge: Cumberland Lodge, Windsor, 27–29 July 2008. Network for Comfort and Energy, London. Available at <http://nceub.org.uk>. Accessed 20 Jan 2019
- Healy JD, Clinch JP (2002) Fuel poverty, thermal comfort and occupancy: results of a national household-survey in Ireland. *Applied Energy* 73(3–4):329–343. [https://doi.org/10.1016/S0306-2619\(02\)00115-0](https://doi.org/10.1016/S0306-2619(02)00115-0)
- Hifumi T, Kondo Y, Shimuzu K, Miyake Y (2018) Heatstroke. *J Intensive Care* 6:30. <https://doi.org/10.1186/s40560-018-0298-4>
- Hoegh-Guldberg O, Jacob D, Taylor M, Bindi S, Brown I, Camiloni A, Diedhiou R, Djalante K.L, Ebi F, Engelbrecht J, Guiot Y, Hijjoka S, Mehrotra A, Payne S.I, Seneviratne A, Thomas Warren R, Zhou G (2018) Impacts of 1.5 °C of global warming on natural and human systems. In:

- Masson-Delmotte V, Zhai P, Portner HO, Roberts D, Skea J, Shukla PR, Pirani A, Moufouma-Okia W, Pean C, Pidcock R, Connors S, Matthews JBR, Chen Y, Zhou X, Gomis MI, Lonnoy E, Maycock T, Tignor M, Waterfields T (eds) Global warming of 1.5 °C. An IPCC Special Report on the impacts of global warming of 1.5 °C above pre-industrial levels and related global greenhouse gas emission pathways, in the context of strengthening the global response to the threat of climate change, sustainable development, and efforts to eradicate poverty. [In Press]. <https://www.ipcc.ch/sr15/chapter/spm/>
- Hubbart J, Link T, Campbell C, Cobos D (2005) Evaluation of a low-cost temperature measurement system for environmental applications. *Hydrol Process* 19:1517–1523. <https://doi.org/10.1002/hyp.5861>
- IPCC (2007) Climate change 2007: the physical science basis: contribution of Working Group 1 to the Fourth Assessment Report of the Intergovernmental Panel on Climate Change. Cambridge University Press, Cambridge, UK/New York. [https://wg1.ipcc.ch/publications/wg1-ar4/faq/docs/AR4WG1\\_FAQ-Brochure\\_LoRes.pdf](https://wg1.ipcc.ch/publications/wg1-ar4/faq/docs/AR4WG1_FAQ-Brochure_LoRes.pdf)
- Johnson AN, Boer BR, Woessner WW, Stanford JA, Poole GC, Thomas SA, O'Daniel SJ (2005) Evaluation of an inexpensive small-diameter temperature logger for documenting ground water-river interactions. *Groundwater Monitoring & Remediation* 25(4):68–74. <https://doi.org/10.1111/j.1745-6592.2005.00049.x>
- Kane T (2013) Indoor temperatures in UK dwellings: investigating heating practices using field survey data. Ph.D. thesis, Loughborough University Institutional Repository. <https://hdl.handle.net/2134/12563>
- Kavgic M, Summerfield A, Mumovic D, Stevanovic ZM, Turanjanin V, Stevanovic ZZ (2012) Characteristics of indoor temperatures over winter for Belgrade urban dwellings: indications of thermal comfort and space heating energy demand. *Energy Buildings* 47:506–514. <https://doi.org/10.1016/j.enbuild.2011.12.027>
- Kinnane O, Grey T, Dyer M (2016) Adaptable housing design for climate change adaptation. *Proc Inst Civ Eng Eng Sustain* 170(5):249–267. <https://doi.org/10.1680/jensu.15.00029>
- Kovats SR, Hajat S (2008) Heat stress and public health: a critical review. *Annu Rev Public Health* 29:41–55. <https://doi.org/10.1146/annurev.publhealth.29.020907.090843>
- Lee K, Lee D (2015) The relationship between indoor and outdoor temperature in two types of residence. *Energy Procedia* 78:2851–2856. 6th international building physics conference, IBPC 2015. <https://doi.org/10.1016/j.egypro.2015.11.647>
- Loughnan M, Carrol M, Tapper NJ (2015) The relationship between housing and heatwave resilience in older people. *Int J Biometeorol* 59:1291–1298. <https://doi.org/10.1007/s00484-014-0939-9>
- Magalhaes SMC, Leal VMC, Horta IM (2016) Predicting and characterizing indoor temperatures in residential buildings. Results from a monitoring campaign in Northern Portugal. *Energy Buildings* 119:293–308. <https://doi.org/10.1016/j.enbuild.2016.03.064>
- Makaka G, Meyer E (2005) Temperature stability of traditional and low-cost modern housing in the Eastern Cape, South Africa. *J Build Phys* 30(1). <https://doi.org/10.1177/1744259106065674>
- Malama A, Sharpless S (1996) Thermal performance of traditional and contemporary housing in cool-season of Zambia. *Build Environ* 32(1):69–78. [https://doi.org/10.1016/S0360-1323\(96\)00036-4](https://doi.org/10.1016/S0360-1323(96)00036-4). 1997
- Matandirotya NR, Cilliers DP, Burger RP, Language B, Pauw C, Pikheth SJ (2019) The potential for domestic thermal insulation retrofits on the South African Highveld. *Clean Air J* 29(1). <https://doi.org/10.17159/2410-972X/2019/v29n1a1>
- Mavrogianni A, Davie M, Wilkinson P, Pathan A (2010) London housing and climate change: impact on comfort and health-preliminary results of a summer overheating study. *Open House Int* 35(2):49–59
- Miguel-Bellod JS, Gonzalez-Martinez P, Sanchez-Ostiz A (2018) The relationship between poverty and indoor temperatures in winter: determinants of cold homes in social housing contexts from 40s–80s in Northern Spain. *Energy Buildings* 173:428–442. <https://doi.org/10.1016/j.enbuild.2018.05.022>
- Myers J, Young T, Galloway M, Manyike P, Tucker T (2011) A public health approach to the impact of climate change on health in Southern Africa-identifying priority modifiable risk. *S Afr Med J*

- = Suid-Afrikaanse tydskrif vir geneeskunde 101(11):817–820. <https://doi.org/10.7196/samj.5267>
- Naicker N, Teare J, Balakrishna Y, Wright CY, Mathee A (2017) Indoor temperatures in low-cost housing in Johannesburg. *Int J Environ Res Public Health* 14(11). <https://doi.org/10.3390/ijerph14111410>
- Robinson PJ (2000) On the definition of a heat wave. *J Appl Meteorol* 40. [https://doi.org/10.1175/1520-0450\(2001\)040<0762:OTDOAH>2.0.CO;2](https://doi.org/10.1175/1520-0450(2001)040<0762:OTDOAH>2.0.CO;2)
- Smargiassi A, Fournier M, Griot C, Baudouin Y, Kosatsky T (2008) Prediction of the indoor temperatures of an urban area with an in-time regression mapping approach. *J Expo Sci Environ Epidemiol* 18:282–288. <https://doi.org/10.1038/sj.jes.7500588>
- Summerfield AJ, Lowe RJ, Bruhns HR, Caeiro JA, Steadman JP, Oreszczyn T (2007) Milton Keynes Energy Park revisited: changes in internal temperatures and energy usage. *Energ Buildings* 39:783–791. <https://doi.org/10.1016/j.enbuild.2007.02.012>
- Szekely M, Carletto L, Garami A (2015) The pathophysiology of heat exposure. *Temperature* 2 (4):452. <https://doi.org/10.1080/23328940.2015.1051207>
- Webber T, Haensier A, Rechid D, Pfeifer S, Eggert B, Jacob D (2018) Analysing regional climate change in Africa in a 1.5,2 and 3 °C global warming world. *Earth's Future* 6:643–655. <https://doi.org/10.1002/2017EF000714>
- White-Newsome JL, Sanchez BN, Jolliet O, Zhang Z, Parker EA, Dvonch JT, O'Neil MS (2012) Climate change and health: indoor heat exposure in vulnerable populations. *Environ Res* 112:20–27. <https://doi.org/10.1016/j.envres.2011.10.008>
- Wittenberg M, Collinson M (2017) Household formation and household size in post-apartheid South Africa: evidence from the Agincourt sub-district 1992–2012. *Demogr Res* 37:Article 39, 1297–1326. <https://doi.org/10.4054/DemRes.2017.37.39>
- Wright CY, Street RA, Cele N, Kunene Z, Balakrishna Y, Albers PN, Mathee A (2017) Indoor temperatures in patient waiting rooms in eight rural primary health care centres in Northern South Africa and the related potential risk to human health and wellbeing. *Int J Environ Res Public Health* 14(1):43. <https://doi.org/10.3390/ijerph14010043>
- Yohanis Y, Mondol D (2010) Annual variations of temperature in a sample of UK dwellings. *Appl Energy* 87:681–690. <https://doi.org/10.1016/j.apenergy.2009.08.003>. (2009)

**Open Access** This chapter is licensed under the terms of the Creative Commons Attribution 4.0 International License (<http://creativecommons.org/licenses/by/4.0/>), which permits use, sharing, adaptation, distribution and reproduction in any medium or format, as long as you give appropriate credit to the original author(s) and the source, provide a link to the Creative Commons license and indicate if changes were made.

The images or other third party material in this chapter are included in the chapter's Creative Commons license, unless indicated otherwise in a credit line to the material. If material is not included in the chapter's Creative Commons license and your intended use is not permitted by statutory regulation or exceeds the permitted use, you will need to obtain permission directly from the copyright holder.





# Smallholders Use of Weather Information as Smart Adaptation Strategy in the Savannah Area of Ondo State, Nigeria

# 77

Rasheedat Alliagbor, David Olufemi Awolala, and Igbekele Amos Ajibefun

## Contents

Introduction .....	1602
Materials and Methods .....	1604
Econometric Model .....	1605
Heckman Two-Step Procedure .....	1605
Results and Discussions .....	1607
Drivers of Farmers' Use of Weather Information for Smart Decisions .....	1607
Conclusions and Policy Recommendations .....	1608
References .....	1609

## Abstract

Weather information is needed for smart decisions because uncertainties in weather phenomena are beyond capacity of smallholders for autonomous responses. The study analyzed determinants of farmers' use of weather information as smart adaptation strategy. Arable crop farmers were sampled in the derived

This chapter was previously published non-open access with exclusive rights reserved by the Publisher. It has been changed retrospectively to open access under a CC BY 4.0 license and the copyright holder is "The Author(s)". For further details, please see the license information at the end of the chapter.

R. Alliagbor (✉)

Department of Agricultural and Resource Economics, Federal University of Technology Akure, Akure, Ondo, Nigeria

e-mail: [jessicaalliagbor@gmail.com](mailto:jessicaalliagbor@gmail.com)

D. O. Awolala

African Climate Change Leadership Program (AfriCLP), University of Nairobi, Kenya and Institute of Resource Assessment, University of Dar es salaam, Dar es Salaam, Tanzania

e-mail: [ddawolala@gmail.com](mailto:ddawolala@gmail.com)

I. A. Ajibefun

Department of Agricultural Economics and Rural Sociology, Auburn University, Auburn, AL, USA

e-mail: [iajibefun@yahoo.com](mailto:iajibefun@yahoo.com)

© The Author(s) 2021

W. Leal Filho et al. (eds.), *African Handbook of Climate Change Adaptation*,  
[https://doi.org/10.1007/978-3-030-45106-6\\_126](https://doi.org/10.1007/978-3-030-45106-6_126)

1601

savannah agro-ecology area of Ondo State, Nigeria. Heckman probit model estimates show that gender and agricultural extension services were significant positive drivers of farmers' access to weather information. Should weather information becomes an alternative adaptation strategy, access to credit was found as the major driver of farmers' propensity to use weather information before taking climate smart agricultural decisions. Further results reveal that increasing knowledge of onset date, large farm size, and access to agricultural extension services significantly reduced farmers' propensity to use improved weather information for smart decisions in the dry savannah area.

---

**Keywords**

Extreme weather · Weather information · Adaptation responses · Smart decisions · Heckman Probit · Ondo State

---

**Introduction**

Climate change is a particular threat to continued economic growth and livelihoods of vulnerable populations (UNEP 2018). The United Nations Development Programme (2011) confirms that Africa faces considerable challenges in adapting to the long-term impacts of climate change and extreme climate events. Extreme events have led to severe economic losses over the years and have increase farmers' needs for weather forecast information that will enable predictions beyond the timeline of indigenous knowledge in decision-making processes. Agricultural stakeholders have to contend with the high vulnerability due to low levels of adaptive capacity and poor weather services across many developing economies. Ensuring that decision makers and end users especially smallholders are able to respond to the medium- and long-term implications of climate change is important in promoting climate-resilient development (Ziervogel and Zermoglio 2009).

Jones and Carabine (2013) observed that the need for medium- and long-term climate information to support climate-resilient development planning in Africa is clear to generate long-term strategies for loss and damage, adaptation finance, climate resilient agricultural practices, and other variants such as climate-compatible development. In the Sub-Sahara Africa, farming systems are highly reliant on prevailing environment, and the existence of traditional knowledge offers elements of resilience (FAO 2011).

In managing the adverse impacts of extreme climate events and climate variability, local farmers have to adjust to harsh weather conditions by relying on weather forecast services which would help moderate potential damage and adverse consequences. The accessibility and usefulness of weather information are therefore critical factors that will affect farmer's ability to adapt (Alston 2013; Serna 2011; Bryan et al. 2009).

In Nigeria, the agricultural production system is predominantly rain-fed, hence highly vulnerable to seasonal variability which affects agricultural livelihood of



smallholders and landless laborers who depend on agriculture, as one of the most vulnerable countries among developing African economies (Vermeulen et al. 2012). The impacts of long droughts and deficit rainfall will be mostly felt by the rural population who represent over 80% of the Nigerian population who have less means to adapt and/or diversify their livelihoods (World Bank 2013). Nigeria may lose about 11% of GDP (\$460 billion) to drought risk event by 2020 and about 25% by 2050.

Smallholders usually depend on traditional weather predictions in taking production decisions (Mugabe et al. 2010). A variety of traditional indicators have been developed in taking decisions weather-dependent farm management decisions. Over time, some traditional weather and climate indicators consequently are no longer patterned base on existing climate behavior (Sanni et al. 2012). Variability in weather parameters has resulted into significant changes in agricultural production cycle such that farmers can no longer accurately predict start and duration of rainfall seasons by relying on indigenous knowledge (Awolala 2018; Madzwamuse 2010). Weather information has shown potential for improving resilience of agriculture to climate shocks and uncertainty, as a fundamental basis upon which smallholders will adapt to effects of climate change (Food and Agriculture [FAO] 2013, 2015).

Nigeria plans “Climate-Smart Agriculture” under the Nigeria’s National Determined Contributions of COP21 Paris Agreement for which weather and climate information services are foremost safety nets. Adapting to impacts through access to timely weather forecasts and other adaptive mechanisms are foremost in Africa’s policy dialogues and socio-economic development agendas (Oyekale 2015).

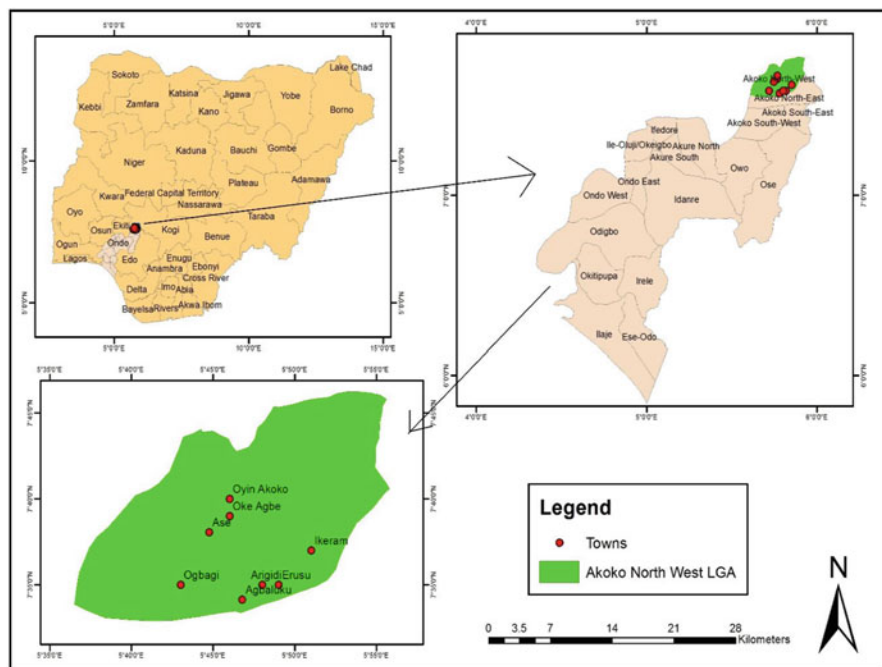
Policy makers’ have thus considered several alternatives for enhancing farmers’ adaptive capacity in the face of changing climatic parameters. A national strategy towards climate resilience, therefore, is to strengthen local resilience and adaptive capacity of vulnerable smallholders to facilitate their investments in Climate Smart Agriculture National Adaptation “Action” Plan towards a resilient agricultural sector (IFAD 2017; CCAFS 2015). One of the strongly identified pathways to meet this Action Plan is the utilization of weather and climate information to facilitate smallholder decisions for adaptation planning. Despite the inherent uncertainties that are associated with climate science and weather forecasting in making informed decisions on agricultural investments aimed at optimizing use of scarce resources available, there is no enough evidence of understanding gaps in the uptake of weather forecast information for long-term strategies of climate resilience, particularly in the Sub-Saharan Africa including Nigeria (African Climate Policy Centre [ACPC] 2011).

While studies in developed countries reveal that farmers benefit substantially from using seasonal forecasts (Mjelde et al. 2000), seasonal weather information has nevertheless been found to have very minimal impacts as it remains largely unutilized by smallholder farmers in Nigeria despite facing food deficits (Awolala 2018). This study analyzed major drivers of farmers’ use of weather information as basis for adaptation decisions in the savannah area of Ondo State, Southwest of Nigeria.

## Materials and Methods

The study site was the Derived Savannah agro-ecology of Akoko North-West Local Government Area of Ondo State, Nigeria. Akoko North-West is located between latitudes  $7^{\circ} 38'$  and  $7.6^{\circ} 27.6' N$  and longitudes  $5^{\circ} 47'$  and  $5.8^{\circ} 38.4' E$  of the equator with an elevation of 486 m in Guinea Savannah agro-ecological zone (accessed from Google maps, 2017). Akoko North-West Local Government Area has an estimated population of 213,792 and covers a total area of 512 km<sup>2</sup> (National Population Census 2006). Ondo State is located in the Southwest of Nigeria, entirely within the tropics with tropical climate broadly classified into rainy season (April–October) and dry season (November–March). Temperature throughout the year ranges between 21 °C to 30 °C and humidity is relatively high. The annual rainfall varies from 2,000 mm in the south to 1,150 mm in the north. Ondo State enjoys luxuriant vegetation with high forest zone (rainforest) in the south and subsavannah forest in the northern fringe (accessed from <http://www.coastalnews.com/profile/government-profile> profile) (Fig. 1).

Cross-sectional data used for this study were obtained using a structured questionnaire administered during a farm field survey of arable food crop farmers. Multistage sampling technique was used to select the respondents. In the first stage, Akoko North-West Local Government Area (LGA) was



**Fig. 1** Map of Akoko North-West showing selected villages in Ondo State

purposively selected in guinea savannah agro-ecological zone of Ondo State given its dominance of major production of cereals and high dry vegetation. This zone is characterized by low rainfall and long dry period. The savannah area, however, has the potential for producing major food staples in meeting consumption and export requirement towards 2023 National Food Security Agenda in the State. In the second stage, eight farming communities were randomly selected from Akoko North-West LGA using a simple random sampling technique. The final stage involved the random sampling of 20 respondents in each farming community which resulted into a total of a hundred and sixty respondents sampled for the study.

## Econometric Model

### Heckman Two-Step Procedure

Heckman Probit Model was used to Analyse Determinant of Smallholders' Use of Weather Information in decision making processes. When a decision process by farmers to adopt an innovative strategy requires more than one step, models with two-step regressions are usually used to correct for the selection bias generated during the decision-making processes which implies the use of Heckman's Sample Selectivity Probit Model (Heckman 1976; Maddison 2006). For model specification, the first step involved the analysis of determinants of access to weather forecast information (selection model) and the second step was the smart decision taken, conditional on the first stage of access to weather information (outcome model), adapted from Awolala et al. and Oyekale (2015). The Probit model for sample selection assumes that there exists an underlying relationship. The latent equation is given by:

$$y_j^* = x_j\beta + u_{1j} \quad (1)$$

Such that the binary outcome is only observed given by the Probit model as:

$$y_j^{probit} = (y_j^* > 0) \quad (2)$$

The dependent variable is observed only if the observation "j" is observed in the selection equation:

$$y_j^{select} = (z_j\delta + u_{2j} > 0) \quad (3)$$

$$u_1 \approx N(0, 1)$$

$$u_2 \approx N(0, 1)$$

$$corr(u, u_2) = \rho$$

where,  $x$  is a  $k$ - vector of regressors,  $z$  is an  $m$ -vector of regressors;  $u_1$  and  $u_2$  are error terms jointly normally distributed, independently of  $x$  and  $z$  with zero expectations. When  $\rho \neq 0$ , standard Probit techniques apply to Eq. (3) give biased results. Hence, the Heckman Probit provides consistent, asymptotically efficient estimates for all parameters in such models (StataCorp 2003). Therefore, to analyze the determinant of farmers' utilization of weather forecast information in taking specific adaptations decisions, the marginal effects of a unit change in an independent variable on the probability  $P(Z = 1 | X = x)$  were obtained given that all other variables are held constant. It is mathematically expressed as:

$$\frac{\delta P(Z_i = 1|x_i)}{\delta x_i} = \frac{\delta E(Z_i = 1|x_i)}{\delta x_i} = \varphi(x_i'\beta) \quad (4)$$

Table 1 presents variables that were analyzed in the Heckman two-step econometric model.

**Table 1** Variable list for the econometric analysis

Variables	Descriptions	Measurements
<i>Dependent variables</i>		
Agricultural smart decisions	Smart agricultural decisions taken by farmers, given weather information received (Yes = 1)	Yes = 1; 0 if otherwise
Farmer's access to weather information	Farmer has access to weather information	
<i>Independent variables</i>		
Gender	Gender of farmer	Female = 1; 0 if otherwise
Farming experience	Farming experience of household head	Number
Farm size	Farm size cultivated	Hectares (ha)
Credit	Access to agricultural credit finance	Yes = 1, 0 if otherwise
Agricultural extension access	Access to agricultural extension services	Yes = 1, 0 if otherwise
Farmers Group membership	Hold membership of Farmers Group	Yes = 1, 0 if otherwise
Access to weather forecasts	If farmer receives weather information	Yes = 1, 0 if otherwise
<i>Weather information</i>		
Rainfall onset date	Rainy season onset date	Yes = 1, 0 if otherwise
Cessation date	Rain cessation date	Yes = 1, 0 if otherwise
<i>Agricultural decisions</i>		
Taking Smart Agricultural decisions	Has taken smart adaptation practices	Yes = 1, 0 if otherwise

Source: Authors 2017

## Results and Discussions

### Drivers of Farmers' Use of Weather Information for Smart Decisions

The result from the Heckman two-step regression estimates result in Table 2 reveals that access to credit is a major driver increasing farmers' propensity to adapt with climate-smart practices at 5% level of significance while increasing access to information onset date, farm size, access to extension reduce farmers' their ability to take climate-smart actions in the derived savannah area. However, gender and access to agricultural extension service were major drivers positively facilitating access to weather information while farmers' experience negatively influence farmers' access to weather information in the derived savannah area of Ondo State, Nigeria.

Access to credit has a positive coefficient with the adoption of climate-smart practices ( $p < 0.05$ ). An increase in access to credit will increase the likelihood that farmers would adopt climate-smart adaptation practices conditional on access to weather forecast information. It is viewed that with credit facilities, interested farmers will be able to bear the cost associated with climate smart practices. For instance, when there is a forecast that rainfall is likely to be unusually low, farmers can grow crops that are drought resistant and sensitive to water availability

**Table 2** Heckman estimates of major drivers of farmers' use of weather information

Variables	Coefficient	Standard error	Z-value	P>z
Taken smart agricultural decisions				
Access to rainfall onset date	-0.2677499	0.1405112	-1.91	0.057 <sup>a</sup>
Access to rainfall cessation date	0.1754594	0.1307748	1.34	0.180
Farm size in hectares	-0.0765449	0.0403879	-1.90	0.058 <sup>a</sup>
Access to agricultural extension service	-0.0335072	0.3270912	-0.10	0.918
Access to credit	0.2943015	0.1500301	1.96	0.050 <sup>b</sup>
Constant	0.6239116	0.5747793	1.09	0.0278 <sup>b</sup>
Access to weather information				
Gender	0.9495208	0.2676775	3.55	0.000 <sup>b</sup>
Farming experience	-0.0417005	0.0096622	-4.34	0.000 <sup>b</sup>
Access to agricultural extension service	0.736214	0.3857535	1.91	0.056 <sup>a</sup>
Constant	0.3007832	0.4244483	0.71	0.479
Total observations	160			
Censored obs	99	Uncensored obs	61	
Prob > chi <sup>2</sup>	0.0621			

Source: Field Survey 2017

<sup>a</sup>Statistically significant at 0.05

<sup>b</sup>Statistically significant at 0.1

to improve profit unlike farmers who also received forecast information but lack access to credit. Therefore, credit facility should be strengthened for smallholders' adoption of climate-resilient technology adaptation actions in the derived area.

Seasonal rainfall onset date and farm size both have negative coefficients with the adoption of climate-smart adaptation practices ( $p < 0.05$ ). An increase in access to seasonal rainfall onset date, likewise increase in farm size, will reduce the likelihood that farmers would adopt climate-smart adaptation practices conditional on access to weather forecast information. These are important policy drivers that should be addresses because they signal danger to farmers' adaptation with climate-smart practices conditional on access to weather forecast information. There are certain socioeconomic and cultural factors which might be responsible for such findings. It is also believed that medium and large-scale farmers might be reluctant in taking climate-smart decisions due to the huge costs involved.

The positive coefficient of gender and access to extension service are both significant at 5% level ( $p < 0.05$ ). The result implies that male farmers are more likely to have access to scientific weather forecast information unlike their female counterparts. It thus becomes obvious that this male farming population should be given attention as major pathway to ensure farmers' resilience with regards to utilization of scientific weather forecast information.

Likewise, increase in access to agricultural extension service, it will be more likely that farmers would have access to weather forecast information in the study area. This is because the role of agricultural extension is critical to move weather forecast information from weather service providers especially the Nigerian Meteorological Agency (NiMet) and other weather forecast agencies in other to ensure a return on investment by translating new knowledge into innovative practices which will enhance farmers' resilience.

Further results explained the negative coefficient of farmers' experience with access to weather forecast information ( $p < 0.05$ ). As farmers' experiences increase, there is a declining likelihood that they will have access to scientific weather forecast information. This might be attributed to their over reliance on traditional experience and knowledge of monitoring weather with local indicators in the study area. This is another important policy variable indicating that there should be improvements in farmers literacy and awareness campaign to encourage the use of scientific-based weather forecasts information to help facilitate climate-smart adaptation actions other than traditional forecasting techniques in the dryland. Table 2 presents the econometric results of factors influencing the use of weather information for smart decisions in the study area.

---

## Conclusions and Policy Recommendations

Access to rainfall cessation date has a positive significant effect on farmers' use of improved weather information. Increasing access to seasonal rain probabilities forecast through information sharing increases the likelihood that farmers will use improved weather information for smart production decisions. Weather services

such as rainfall forecasts and advisory planting calendars based on length of growing season should be location specific and timely communicated by the Nigerian Meteorological Agency (NiMet) in a mode that is understood at farmers' level. Such information on rainfall cessation date is considered significantly helpful for farmers adaptation planning and resilience.

Credit also significantly facilitates farmers' use of weather information in taking climate-smart decisions. It is viewed that with credit facilities, interested farmers will strengthen their adaptive capacity to afford whatever transaction cost that might be associated with climate smart practices if they have adequate financial assistance. Better incentive-based credit facility should be developed as a farmer-oriented financial product to strengthen smallholders' decisions for climate-resilient technology actions in the dry land area. Similarly, Policy makers should ensure functioning financial institutional services especially rural access to bank credits and informal credits are available to help farmer's withstand unforeseen circumstances that may arise from investing in innovative climate smart practices.

In terms of access, male farmers were found to have more access to weather information. Agricultural decisions are traditionally considered as responsibility of the household head, and most of the times, it is the male gender. Therefore, weather information utilization could be more guaranteed when male farmers are used as an entry point to allow for quick and wider coverage among farmers given their strong influence as decision makers. Policy makers and agricultural stakeholders at the federal, state, and local government levels must ensure that rural education is provided for male household heads to fast-track local uptake of improved weather information as weather risk adaptation strategy.

Better access to agricultural extension services also increase farmers' likelihood to have access to weather forecasts. Agricultural Extension Department at the Ministry of Agriculture and Rural Development must ensure that periodic extension education and training services serve as opportunities to share updated information on weather with farmers and provide advisory services on smart agro-weather management technologies. A functional and effective extension service system has great potential in facilitating early action on weather risk management through climate smart practices by the increasing farming population in the derived savannah area of Ondo State, Nigeria.

These drivers should be considered for a review as strategies for implementing the National Climate Smart Agriculture Adaptation Plan (NCSAAP) in Ondo State, Nigeria, as stated in the revised National Agricultural Policy which targets agricultural livelihood resilience towards meeting the 2030 National Food Security Agenda.

---

## References

- African Climate Policy Center [ACPC] (2011) Assessment of Africa's Climatic records and recording networks including strategic for rescuing of climatic data. Working Paper 3 of the African Climate Policy Center (ACPC) Of United Nations Economic Commission for Africa (UNECA) under the Climate for development in Africa (Climdev Africa) programme

- Alston M (2013) Gender mainstreaming and climate change. *Women's Stud Int Forum* 47:1–8
- Awolala DO (2018) Climate smart adaptations in the African tropics: scaling weather information for decision support outcomes in Nigeria savannahs. In: Leal Filho W (ed) *Handbook of climate change resilience*. Springer, Cham, pp 1–33. [https://doi.org/10.1007/978-3-319-71025-9\\_169-1](https://doi.org/10.1007/978-3-319-71025-9_169-1). Online ISBN 978-3-319-71025-9
- Bryan E, Deressa T, Gbetiboubo GA, Ringler C (2009) Adaptation to climate change in Ethiopia and South Africa: options and constraints. *Environ Sci Pol* 12:413–426
- Climate Change, Agriculture and Food Security [CCAFS] (2015) *Implementing climate-smart agriculture for enhanced food security and resilience*. Progress report led by the International Center for Tropical Agriculture (CIAT) and other Research Centres
- FAO (2011) *Climate change and food systems resilience in sub-saharan Africa* (eds: Ching LL, Edwards S, Scialabba NE-H). Office of Knowledge Exchange, Research and Extension, FAO, Rome
- FAO (2013) *Climate smart agriculture source book*. Food and Agriculture Organization of the United Nations, Rome
- FAO (2015) *Barriers, incentives and benefits in the adoption of climate smart agriculture: enhancing agricultural mitigation within East Africa Dairy Development project (EADD) in Kenya*. FAO, Rome
- Heckman JJ (1976) The common structure of statistical models of truncation, sample selection and limited dependent variables and a simple estimator for such models. *Ann Econ Soc Meas* 5:475–492
- IFAD (2017) *IFAD Strategy and Action Plan on Environment and Climate Change: 2019–2025*. Document: EB 2018/125/R.12.
- Jones L, Carabine E (2013) *Exploring political and socio-economic drivers of transformational climate policy: early insights from the design of Ethiopia's Climate Resilient Green Economy strategy*. Research reports and studies. Overseas Development Institute, London
- Lal R, Kraybill D, Hansen DO, Singh BR, Eik LO (2016) *Research and Development Priorities*. In: Lal R, Kraybill D, Hansen D, Singh B, Mosogoya T, Eik L (eds) *Climate Change and Multi-Dimensional Sustainability in African Agriculture*. Springer, Cham. <https://doi.org/10.1007/978-3-319-41238-2>
- Maddison D (2006) *The perception of and adaptation to climate change in Africa*. Discussion Paper No. 10. Centre for Environmental Economics and Policy in Africa (CEEPA). University of Pretoria, Pretoria
- Madzwamuse M (2010) *Climate governance in Africa: adaptation strategies and institutions*. Heinrich Böll Stiftung (HBS), Nairobi
- Mjelde et al (2000) *Climate change and multi-dimensional sustainability in African agriculture*
- Mugabe FT, Mubaya CP, Nanja DH, Munodawafa A, Gondwe P, Mutswangwa EA, Changonda C, Masere P, Makuvaro V, Dimes J, Murewi C (2010) *Using indigenous knowledge for climate adaptation in Southern Zambia and South-Western Zimbabwe*. *Zimb J Sustain Dev Afr* 11(2):237–256
- NPC (2006) *National Population Census Report*, Nigeria
- Oyekale AS (2015) Factors explaining farm households' access to and utilization of extreme climate forecasts in Sub-Saharan Africa (SSA). *Environ Econ* 6(1): 91–103
- Sanni et al (2012) *Traditional capacity for weather prediction, variability and coping strategies in the front line states of Nigeria*. *Agric Sci* 3:625
- Sema JM (2011) *Drought Assessment Northern Eastern Kenya (Wajir East, South and Mandera)*. Northern Eastern Kenya Drought Assessment Report
- StataCorp (2003) *Stata base reference manual*. Volume 4, G – M, release 8. Stata Corporation, College Station
- UNDP (2011) *Human Development Report 2011. Sustainability and equity: a better future for all*. Palgrave Macmillan, New York
- UNEP (2018) *United Nations Environment Annual Report*
- Vermeulen S, Zougmore R, Wollenberg E, Thornton P, Nelson G, Kristjanson P, Kinyangi J, Jarvis A, Hansen J, Challinor A, Campbell B, Aggarwal P (2012) *Climate change, agriculture*



and food security: a global partnership to link research and action for low-income agricultural producers and consumers. *Curr Opin Environ Sustain* 4:128–133

World Bank (2013) Weather and climate resilience: effective preparedness through National Meteorological and Hydrological Services (NMHSs) in the World Bank Development Report of Rogers DP, Tsirkunov VV (2013) Directions in development – environment and sustainable development. World Bank, Washington, DC

Ziervogel G, Zermoglio F (2009) Climate change scenarios and the development of adaptation strategies in Africa: challenges and opportunities. *Clim Res* 40(2–3):133–146. <https://doi.org/10.3354/cr00804>

**Open Access** This chapter is licensed under the terms of the Creative Commons Attribution 4.0 International License (<http://creativecommons.org/licenses/by/4.0/>), which permits use, sharing, adaptation, distribution and reproduction in any medium or format, as long as you give appropriate credit to the original author(s) and the source, provide a link to the Creative Commons license and indicate if changes were made.

The images or other third party material in this chapter are included in the chapter's Creative Commons license, unless indicated otherwise in a credit line to the material. If material is not included in the chapter's Creative Commons license and your intended use is not permitted by statutory regulation or exceeds the permitted use, you will need to obtain permission directly from the copyright holder.





# ECMWF Subseasonal to Seasonal Precipitation Forecast for Use as a Climate Adaptation Tool Over Nigeria

# 78

Ugbah Paul Akeh, Steve Woolnough, and Olumide A. Olaniyan

## Contents

Introduction .....	1614
Background .....	1614
Review of ECMWF Subseasonal to Seasonal Forecasting .....	1616
Description of the Study Areas and Methodology .....	1617
Study Area .....	1617
Research Methods .....	1619
Results and Discussion .....	1621
Comparison Between Observation and Forecast at Different Lead Times .....	1621
Evaluation of the Forecast Skill: Metrics .....	1622
Conclusion .....	1628
References .....	1629

## Abstract

Farmers in most parts of Africa and Asia still practice subsistence farming which relies mainly on seasonal rainfall for agricultural production. A timely and accurate prediction of the rainfall onset, cessation, expected rainfall amount, and its intra-seasonal variability is very likely to reduce losses and risk of extreme weather as well as maximize agricultural output to ensure food security.

This chapter was previously published non-open access with exclusive rights reserved by the Publisher. It has been changed retrospectively to open access under a CC BY 4.0 license and the copyright holder is “The Author(s)”. For further details, please see the license information at the end of the chapter.

U. P. Akeh (✉) · O. A. Olaniyan  
National Weather Forecasting and Climate Research Centre, Nigerian Meteorological Agency,  
Abuja, Nigeria  
e-mail: [paulugbah@gmail.com](mailto:paulugbah@gmail.com)

S. Woolnough  
Department of Meteorology, University of Reading, Reading, UK  
e-mail: [s.j.woolnough@reading.ac.uk](mailto:s.j.woolnough@reading.ac.uk)

Based on this, a study was carried out to evaluate the performance of the European Centre for Medium-range Weather Forecast (ECMWF) numerical Weather Prediction Model and its Subseasonal to Seasonal (S2S) precipitation forecast to ascertain its usefulness as a climate change adaptation tool over Nigeria. Observed daily and monthly CHIRPS reanalysis precipitation amount and the ECMWF sub-seasonal weekly precipitation forecast data for the period 1995–2015 was used. The forecast and observed precipitation were analyzed from May to September while El Nino and La Nina years were identified using the Oceanic Nino Index. Skill of the forecast was determined from standard metrics: Bias, Root Mean Square Error (RMSE), and Anomaly Correlation Coefficient (ACC).

The Bias, RMSE, and ACC scores reveal that the ECMWF model is capable of predicting precipitation over Southern Nigeria, with the best skill at one week lead time and poorest skills at lead time of 4 weeks. Results also show that the model is more reliable during El Nino years than La-Nina. However, some improvement in the model by ECMWF can give better results and make this tool a more dependable tool for disaster risk preparedness, reduction and prevention of possible damages and losses from extreme rainfall during the wet season, thus enhancing climate change adaptation.

---

#### Keywords

Evaluation · Subseasonal to seasonal (S2S) · Forecast · Metrics · Skill · Climate change adaptation · Ocean Nino Index · ElNino · LaNina · Precipitation amount

---

## Introduction

### Background

Weather and climate affect man in diverse ways which greatly impact agriculture, food security, housing, transportation, health, engineering structures, water resources, military operations, oil exploration and exploitation, environment, livelihoods, etc. (Ugbah 2016). These impacts are usually associated with extreme weather and seasonal hazards such as tropical cyclones, heavy rainfall, flooding, etc., which occur more frequently (IPCC 2018). For these reasons, scientists have continued to invest great time and resources in trying to understand and predict the processes that lead to changes in the atmosphere associated with these hazards. One of such investment is the international project known as the subseasonal to seasonal (S2S) prediction project set up in 2013 by the World Meteorological Organization (WMO), World Weather Research program (WRWP), and World Research and Climate program (WRCP) to provide a common platform for sharing of data and knowledge between countries, National meteorological Agencies, and researchers which will enhance our understanding of seasonal and subseasonal variability and also help to improve the skill and accuracy of long range forecast (weeks–months) and likely extreme events in different parts of the world (Takaya 2015).

In most parts of Asia and Africa and in developing countries such as Nigeria, farmers still practice subsistence farming which relies mainly on seasonal rainfall for Agricultural production (Siegmund et al. 2015; Hansen 2002). Farming, out of all human activities, is the most weather-dependent (Hanson 2002). A timely and accurate prediction of the onset, cessation, expected rainfall of the monsoon season, and its intra-seasonal variability is very likely to reduce losses and risk of extreme weather (Vitart et al. 2016) as well as maximize agricultural output to ensure food security. This is one of the purposes for which the S2S project was set up.

The time range for subseasonal forecast lies between 2 weeks and 60 days (Vitart et al. 2016) within the rainy season and it is meant to “bridge the gap between the medium range forecast” (at most 2 weeks) and seasonal forecast (3–6 months) [Vitart et al. 2016; Molteni et al. 2016]. The Madden Julian Oscillation (MJO), among other factors such as El-Nino Southern Oscillation (ENSO), stratospheric influence, Ice and snow cover, soil moisture, ocean conditions, and tele-connection between the tropics and extra tropics, is said to be the main source of predictability for sub-seasonal time range (Vitart et al. 2016; Inness and Dorling 2010); this may not be unconnected with the fact that MJO plays a significant role in initiating or terminating equatorially trapped waves (Kelvin waves) and Rossby waves (Maclachlan et al. 2015) which influence ENSO phenomena. The choice of the ECMWF forecast rather than others is based on the high skill displayed by the model in simulating MJO over the tropics and extra tropics, and the continuous improvement in skill of predicting subseasonal variability and events up to lead time of 10 days, since 2002. This is attributed to the improvement in the ECMWF model characteristics (resolution, initial conditions, physics, etc.) made possible because of the advancement in information technology which has led to the production of better computers with higher computational capabilities, capacity, and speeds in recent times. This development gives a ray of hope to those who depend on subseasonal to seasonal rainfall for production, planning, decision making, disaster preparedness, and socioeconomic development, thus the need to embrace the S2S project.

This study was done in 2016 with the aim of assessing the skill of ECMWF subseasonal ensemble forecasting system in simulating subseasonal rainfall variability in terms of pattern and amount of rainfall in Nigeria up to lead time of one month specifically over southern Nigeria where annual rainfall is highest and the risk of flooding from excessive rainfall also high. The area is highly threatened by sea level rise especially during the rainy season. This work also investigates how good the S2S model ensemble is, in predicting the likelihood of extreme rainfall that may cause flooding over the region.

The scope of this work is limited to southern Nigeria only where risk of flooding is highest and does not cover the entire country. Also it does not include evaluation of how the model can simulate or predict rainfall onset, cessation, or length of season but rainfall amount and pattern. It is expected that findings from this research will not only help to improve the quality and accuracy of S2S forecast, but will also help in updating the seasonal forecast of Nigerian Meteorological Agency and provide useful information and early warning system for disaster preparedness and risk reduction against extreme weather and climate events such as flooding.

## Review of ECMWF Subseasonal to Seasonal Forecasting

In 2002, Frederic Vitart started the ECMWF medium range (monthly) forecast of precipitation as an experimental phase which became fully operational by 2004. It was integrated with the ensemble prediction system in 2008 following results of improved skill in simulation of weekly surface temperature, precipitation, mean sea level, and MJO observed during the period over the extra-tropics (Vitart 2005, 2014; Vitart et al. 2016). The model is run two times in a week to produce a daily forecast in real time for lead period up to 32 days, with a 1 hourly high resolution retrieval, and a reforecast (hindcast) for more than 12 years (Molteni et al. 2016; Vitart et al. 2016). The forecast consists of 51 ensemble members while the reforecast has 11. According to Vitart et al. (2016), it is structured to allow better coupling of the atmosphere (IFS model) and ocean (NEMO model) compared to models used in NOAA and UKMet office. Representation of model physics and physical processes has also been improved in very recent version. Some of the improvements include the increase in frequency of the S2S forecast from every 14 days in 2002 to twice a week from 2013 to date. The horizontal resolution has also evolved from T159 which had a lead time up to 32 days in 2002, through T255, T319, and presently T639 with lead time of up to 46 days. Vertical resolution has also improved from 40 atmospheric levels with top at 10 hPa in earlier versions to 91 atmospheric levels with top at 1 Pa in 2016. Re-forecast size now has 11 ensemble members as against 5 members in earlier versions (Molteni et al. 2016).

Work by Vitart (2005; Vitart et al. 2016) in trying to evaluate the skill of ECMWF subseasonal forecast showed higher weekly scores for lead times greater than 10 days and better skills when compared to persistent forecast and climatology (Vitart 2005; Vitart et al. 2016; Haiden et al. 2015). In another work, verification of the ECMWF subseasonal forecast model was done using metrics such as anomaly **coefficient of correlation (ACC) and root mean square error RMSE and probabilistic skills** (Vitart 2004). This approach is very popular and it is in line with the WMO recommendation on verification of deterministic forecast (Inness and Dorling 2010). **Vitart's result showed decreased correlation in the weekly anomalies with increasing lead time; the highest correlation value was observed in the first week forecast.** The skill was found to be greater than skill of the persistence forecast. For the ensemble probability forecast, the relative operative characteristics (ROC) scores which show the ratio between the Hit rate and false alarm were determined using the contingency table. ROC value of 0.5 means "no skill forecast" while values above 0.5 suggest good skill of forecast. The ROC values obtained from Vitart's work showed that forecast of 12–18 days was better than persistence forecast of 5–11 days. His work in 2014 also confirms this, with highest skill for week 1 (0.8) decreasing to 0.6 during week 3 (Vitart 2014). Brier score of ECMWF subseasonal forecast was 0.04 which suggested that model performed better than climatology (Vitart et al. 2016). The result of evaluation of the ECMWF subseasonal forecast showed better performance than other global centers as seen from the studies of Vitart over the extra tropics and consistent with other centers (Haiden et al. 2014). He pointed out that there could be variability in scores from one region

to another and so, it would be wrong to conclude that the African region with a different climate, weather and geomorphology, will produce same skill as the extra-tropics without carrying out studies to compare and make valid conclusions, hence the justification for this study over Nigeria.

Li and Robertson (2015) also carried out studies to evaluate precipitation forecast from global ensemble prediction system at submonthly timescales using hind cast data from three global prediction centers (ECMWF, NCEP, and JMA) during May to September for the period 1992–2008. Statistical metrics used were the Correlation of Anomalies (CORA), and the Mean Square Skill Score (MSSS). The results showed good skills from all the three models during the first week compared to lead times of 2–4 weeks. The skill from ECMWF forecast was however better than the other two. Anomaly correlation skill scores were found to be high at lead times 1–4 over the equatorial Pacific while values of 0.2–0.3 were found to be statistically significant over tropical Atlantic at lead 1 only. The skills over land areas were generally poor even at lead time of one week over Africa. The result also showed very good correlation between ENSO and the submonthly prediction with ACC skills for ENSO years higher than neutral years. Biases in mean weekly precipitation forecast were large particularly in the NCEP model over the Atlantic, West Africa, and the Sahel regions.

Studies by Hamill (2012) on verification of the ECMWF probabilistic precipitation forecast, TIGGE National Centers for Environmental Prediction (NCEP) model, Canadian model, and UK Met Office (UKMO) forecast models during June–November 2002 to 2009 over the United states of America showed that ECMWF had the best skills with better scores for higher precipitation. These works confirm the leading standard of the ECMWF model forecast which has been chosen for this study.

---

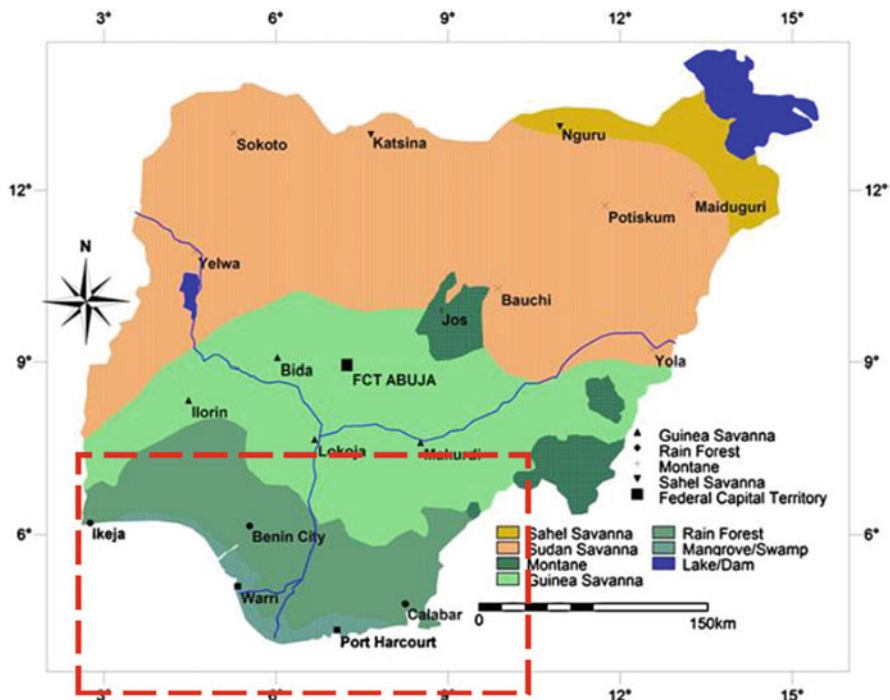
## Description of the Study Areas and Methodology

### Study Area

Nigeria is located towards the coast of West Africa on latitude 4.0°N–14.0°N and longitude 2.45°E–15.5°E (Fig. 1). It occupies a landmass of about 924,000 Km<sup>2</sup> and population of about 133 million as at 2006 which grows at a rate of 2.8% (Ayanlade et al. 2013). The study area is the southern part of the country shown in the red box (Fig. 1) defined by latitude 4.0°N–8.0°N and longitude 2.0°E–11.0°E estimated from the figure which is sourced from Eludoyin and Adelekan (2013). It covers an area less than 50% of the country and is bounded in the South by the Atlantic Ocean (Gulf of Guinea). The area is bounded in the East and West by two countries: Cameroun and Benin Republic, respectively.

### Climatology and Sources of Subseasonal Predictability in the Region

The study area lies within the mangrove swamp, tropical rainforest, and Guinea Savanna vegetative zones which experience two major seasons: Wet (late February



**Fig. 1** Map of Nigeria showing study area in rectangular box (Source: Eludoyin and Adelekan 2013, springer publishers)

to November) and the dry (December to mid-February) as reported by Eludoyin and Adelekan (2013). The unequal distribution of rainfall from month to month within these two major seasons further distinguishes the season into long rainy season (March–July), short dry season or August break (Late July–early August), short rainy season (early September–mid-October), and the long dry season (late October–early March) (Chidiezie and Shrikant 2010). The wet season is said to have a bimodal pattern of rainfall and a longer period which lasts about 200–300 days (NiMet 2013, 2014). It is characterized by moist southwesterly winds also known as the tropical maritime air mass (mT) which blow landwards from the Atlantic Ocean and is predominant during the rainy season. The dominant winds during the short period of dry season (Harmattan season) are the dry dusty northeasterly trade winds from the desert also called the tropical continental air mass (cT) which find their way to the South from the North (Eludoyin & Adelekan 2013). Annual rainfall total ranges from 1500 to 3000 mm over most of the South but can reach about 4000 mm over the southeastern part where rainfall is highest (Ayanlade et al. 2013, Chidiezie and Shrikant 2010). Mean air temperatures are in the range of 25.0°–30.0 °C during summer and 20.0–30.0 °C during the harmattan season (Ayanlade et al. 2013)

## Research Methods

### Study Site Selection and Sampling Methods

The study area covers all locations in southern Nigeria which lie between latitude 4.0 and 8.0 N and longitude 2.0 and 11.0 E which are Bayelsa, Rivers, Akwa-Ibom, Cross-river, Ebonyi, Enugu, Abia, Anambra, Imo, Delta, and Edo states. Others are Ondo, Lagos, Ogun and southern part of Osun, Oyo, Benue, and Kogi states. The selection of the area is intentional for only areas which experience high annual rainfall of 1500 mm and above and prone to high risk of flooding due to the heavy rainfall and proximity to the Atlantic Ocean. The area is also close to rivers Niger and Benue and selected based on three agro-climatic zones: mangrove swamps, tropical rainforest, and Guinea Savanna only. This means that a combination of purposeful and stratified sampling was employed in selecting the study area.

### Data Sources and Collection Methods

Secondary data was used for this study and includes forecast and observed precipitation data for 21 years from 1995 to 2015 over Nigeria. This is the period for which reforecast data was available. The forecast data is the ECMWF ensemble reforecast precipitation data in mm/day downloaded from the S2S data website hosted by ECMWF and it is available up to lead time of 40 days from 11 ensemble members. The mean ensemble precipitation forecast data provided at a resolution of  $1.5^{\circ} \times 1.5^{\circ}$  grids (IRI 2016) was used for this study. The observed rainfall data is the CHIRPS reanalysis of daily precipitation provided at a resolution of  $0.05 \times 0.05$  grid which is higher than the resolution of the forecast data. It was downloaded from the IRI website earlier discussed and credited to Funk et al. (2014).

No missing data was observed in the data sets as it is likely that any existing missing data may have been filled during reanalysis/homogenization before making the data available for users on the websites.

Weekly precipitation totals and climatological averages of observation and forecast from May 14 to September 24 (20 weeks) for the 21 year period (1995–2015) was extracted and used to study the intra-seasonal changes in precipitation. The choice of the seasonal period (May–September) is based on the enormous rainfall usually experienced during this period. ENSO years within the period were selected based on the Oceanic Nino index (ONI) provided by NOAA at <http://www.cpc.ncep.noaa.gov/products/analysismonitoring/ensostuff/ensoyears.shtml>

### Data Analysis

Codes were written first, to read all the data files which were in NetCDF format, and then to convert the time variable which was in Julian days in CHIRPS data to the normal calendar dates to enable easy extraction of weekly totals of precipitation from May 14 to September 24. This was then followed by extraction of weekly means and climatological averages of precipitation over southern Nigeria from which temporal plots were made. Time series were plotted as average weekly while the climatological average was determined from the weekly totals averaged over 21 years. Bias and RMSE between forecast and observed precipitation was calculated accordingly.

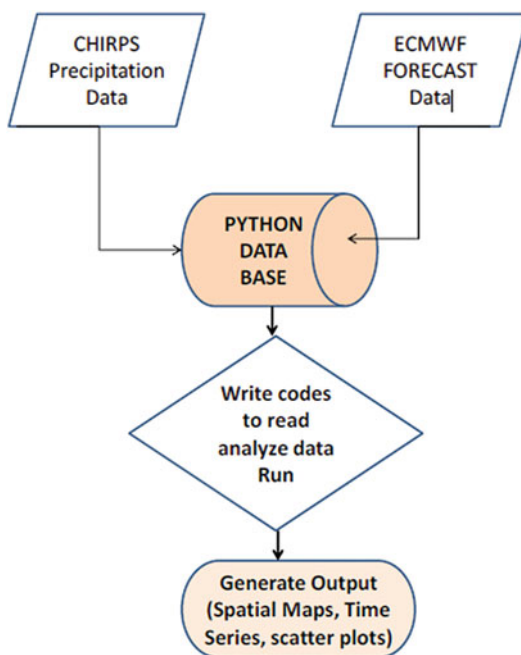


Anomalies were determined by subtracting the climatological mean from the weekly mean precipitation and the anomalies correlated to determine the ACC skill of the forecast at different lead times. All plots as well as calculations were made using Python.

The ECMWF forecast data, unlike CHIRPS, had a land-sea masked file for measurements over land and ocean. This masked file was used to mask out the ocean precipitation values in order to extract only values over land. The step is taken to isolate the land grid boxes when calculating precipitation averages and totals to enable a fair comparison between the data sets.

The observed precipitation for the previous week was persisted for the following week to produce the one week lead time persistent forecast for the 20 weeks period (May 14–September 24). This was then compared with the observed climatology and forecasts at weekly lead times of one, two, three, and four weeks referred to as lead 1, 2, 3, and 4. The El Niño and La Niña events were identified by averaging the five consecutive Oceanic Niño Index (ONI) values of months AMJ, MJJ, JJA, JAS, ASO, and the average was compared with the threshold that defined an ENSO event, that is, ONI values greater or equal to  $+0.5$  °C define an El Niño while values less or equal to  $-0.5$  is La Niña (NOAA 2016). These months were chosen to be consistent with the season (May–September) for which forecast is made. The flow chart (Fig. 2) summarizes the procedure involved.

**Fig. 2** Flow chart of methodology. (Source: Ugbaah 2016)

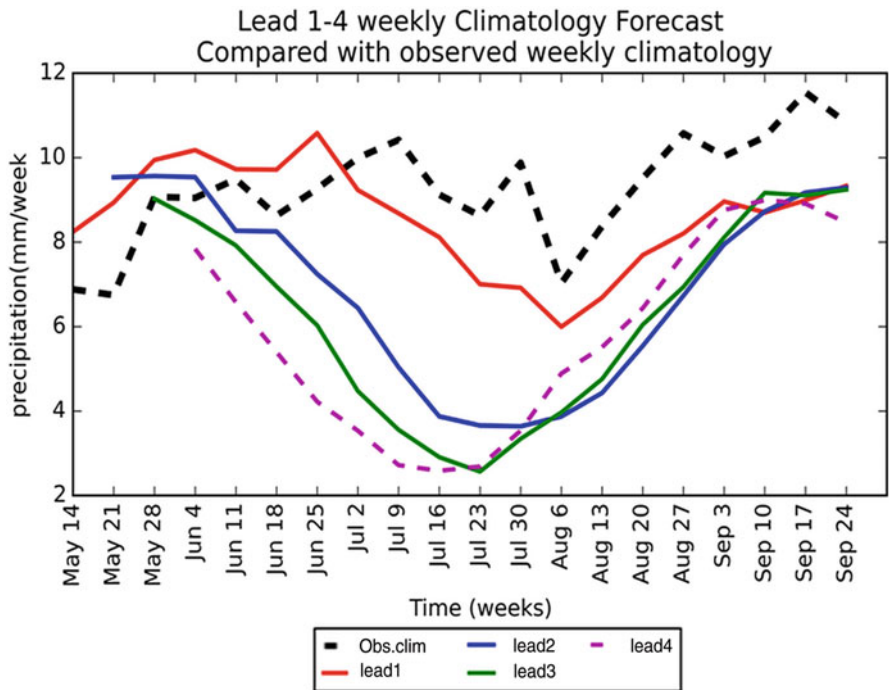


## Results and Discussion

### Comparison Between Observation and Forecast at Different Lead Times

Weekly totals of the forecast and observed precipitation covering the twenty weeks period (May 14 to September 24) from 1995 to 2015 were plotted to compare the extent to which the observation agrees with or deviates from the forecast at different lead times. The result is shown in Fig. 3.

It can be seen from Fig. 3 that both the forecast and observation follow a similar pattern during the season and depict the two peaks (bimodal) of rainfall in early July and in September. The short period of the little dry season known as “August break” is also shown by the precipitation minimum around late July/August. At initial start dates up to June 11 and towards the end of the season in September, the precipitation values all seem to be in close agreement, having only small differences, but beyond the week starting June 11, the forecasts start to deviate significantly from the observed with the largest differences around the period of the little dry season after which the lines begin to converge until the end of the season (Fig. 3). It can also be seen that the differences in precipitation amount increase with increasing lead



**Fig. 3** Forecast at different weekly lead times (wk1-wk4) indicated with colored lines and Observed weekly climatology (black dotted line) compared (Source: Ugba [2016](#))

time as depicted by lead 1 forecast (red line) which lies closest to the observation (dotted black line) throughout the season. Forecast of lead 2, 3, and 4 show larger departures from the observed climatology (Fig. 3) with the largest departure seen in the lead 4 forecast (purple dotted line). These large departures possibly arise from the inability of the model to properly simulate the little dry season phenomenon and related subseasonal processes. Correction of these differences is likely to improve the performance of the model. The plot also shows that the predicted precipitation at all the different lead times is lower than the observed implying an underestimation by the model. This can also be corrected to improve the model.

## Evaluation of the Forecast Skill: Metrics

It is important to explain some of the different scores that are used for evaluating this forecast as there are different types of metrics used for verification of forecast and the choice of a particular type depends on the objective of the verification. Some of the popular metrics used by scientists and recommended by WMO for use in verification of precipitation forecasts include bias, root mean square error (RMSE), and anomaly correlation coefficient (ACC). These metrics have been selected for this study to provide a common standard for comparing the results with those of other scientist and meteorologist on related works.

### Bias

The bias refers to the differences between the forecast and the observation mean. It is a measure of the extent to which the ECMWF model under-estimates or over-estimates precipitation. Bias information is useful in correcting errors in models which are likely to improve its performance (Inness and Dorling 2010). Mathematically it is defined as:

$$\text{Bias} = \sum_{i=1}^n \frac{(f - O)}{N}$$

where  $f$  = forecast,  $O$  = observation, and  $N$  = total number of events.

A larger bias shows large differences or disagreement between forecast and observation while smaller values suggest closeness or similarities. Such closeness may not necessarily mean that the forecast is perfect because observations could be wrong and therefore give misleading results. Bias can be positive when forecast is over-estimated or negative when under-estimated.

The biases were computed at the four different lead times and then averaged over the twenty weeks period from May to September (Table 1). Negative biases can be seen for leads of 1, 2, 3, and 4 weeks. The biases increase with lead time from week one (−0.69) to week four (−3.10). This is consistent with findings from Vitart 2004, 2014, and Li and Robertson (2015). At lead times of 2 to 4 weeks, the dry bias is particularly strong from late June through July. This suggests difficulty by the model

**Table 1** 1995–2015 ECMWF forecast vs observed precipitation scores at weekly lead times

Scores of the ECMWF subseasonal weekly forecast over Southern Nigeria				
Lead time scores	Week 1	Week 2	Week 3	Week 4
BIAS	-0.69	-2.30	-2.7	-3.10
RMSE	1.64	3.33	3.78	3.98

to forecast at a period when reduced rainfall is experienced in the West African Monsoon (WAM) and when the Inter-Tropical Convergence Zone (ITCZ) also called ITD is at its most northward position from the area of study. Such biases may be necessary to correct only if other metrics also provide evidence in support of poor model performance. This is because bias alone is inadequate in evaluating the performance of a model as it only tells only the differences and does not give weight to errors like the RMSE. That is why the use of only one metric is not recommended but a combination of two or more.

**Root Mean Square Error (RMSE)**

RMSE can be defined as the square root of the sum of the squares of all errors (biases) between a given set of data as shown below (Chai and Draxler 2014).

This metric is good for use in evaluating the performance of a model because it represents normally distributed errors better than uniformly distributed errors common in models (Chai and Draxler 2014). It gives more weight to large errors than smaller errors and has a tendency of showing some bias towards datasets without large errors, but it still remains one of the oldest and most popularly used metric among scientists in model evaluation. Large RMSE values imply large error distribution while smaller values suggest smaller errors. RMSE of zero means that the forecast is without errors or bias.

$$RMSE = \sqrt{\sum_{i=1}^N \frac{(f - O)^2}{N}}$$

where  $f$  = forecast,  $O$  = observation,  $N$  = total number of events.

The results of RMSE also show that errors increased with lead time, and were lowest (1.64) at lead time of one week and highest (3.98) at lead time of four weeks (Table 1).

**Anomaly Correlation Coefficient (ACC)**

ACC was used to evaluate the potential skill of the forecast. It is considered a potential skill because it is only one metric out of the several others that need to be considered to arrive at the final or perfect skill of a forecast. It may not be exhaustive, but it provides very useful information for assessing model performance and a pointer to the likely overall skill. Correlation between forecast and CHIRPS observed daily precipitation data was done using python program scripts written to incorporate the mathematical formula for ACC defined by Maue and Langland (2014) as:

$$ACC = \frac{\sum_{m=1}^m f' * O'}{\sqrt{\left( \sum_{m=1}^m (f')^2 * \sum_{m=1}^m (O')^2 \right)}}$$

where  $f' = fm - Cm$ , is the forecast mean ( $fm$ ) – climatological mean of forecast ( $Cm$ )  
 $O' = Om - Cm$ , is the mean of observed ( $Om$ ) – Observed mean Climatology ( $Cm$ ).

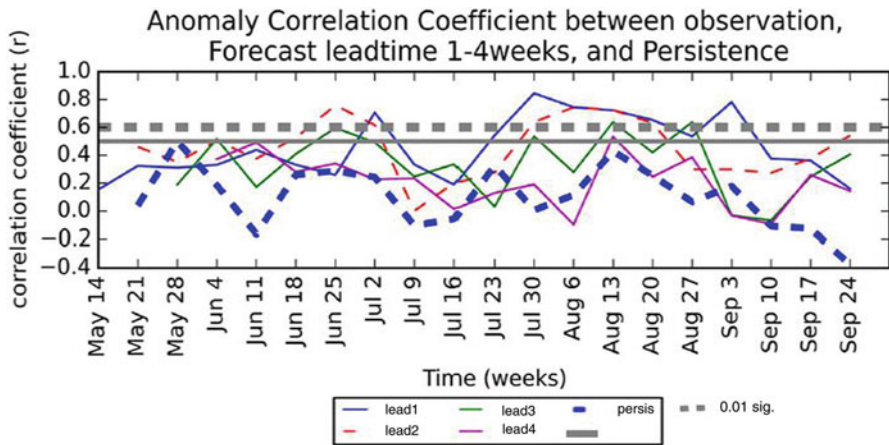
The climatological average values of forecast and observation for the 21 year period was first calculated and then subtracted from each weekly forecast and observed precipitation to get the desired result. Correlation values generated from linear regression analysis of these anomalies also produced similar results when compared. This served as a check for possible computational errors from code written to calculate this metric. One advantage with this metric is the consideration of errors averaged over a longer period than for short period averages which are usually highly variable. This advantage, on the other hand, also constrains the metric in its ability to significantly reflect changes in the mean values over shorter time ranges.

The results of the correlation for weekly start dates during the season and at lead times of the 1, 2, 3, and 4 weeks indicated are further discussed in section “[Performance of the S2S Model Precipitation Forecast During Rainfall Peaks and Period of Little Dry Season](#)”. There are 20 weekly start dates in the season starting with the first on May 14, then May 21, May 28, . . . up to the last date on 24th September.

A forecast can be produced on any of these dates for lead times up to 40 days in advance, but in this study, only lead times up to 4 weeks are considered. This is because such a time period is relatively reliable and adequate for use by farmers especially in Nigeria to plan and make decisions about farming practices such as planting, weeding, fertilizer application, etc. It should be noted also that at longer lead times, forecasts tend to lose accuracy (Inness and Dorling 2010), and so, the weekly to one month lead time forecast chosen is likely to be more reliable than lead time more than one month. In this study, forecast made with a lead time of one week (referred to as lead1) means the forecast is produced on a particular week and is valid for one week (up to the following week). It is also possible to produce a lead 1, 2, 3, or 4 forecast on any of the 20 start dates from May 14 to September 24. The choice of any of the start dates depends on the period of interest within the season and the goal which the user or client wants to achieve or satisfy.

The correlation between the observed and forecast anomalies (ACC) at different lead times and with persistence forecast is shown in Fig. 4.

Seasonal mean ACC values tend to be generally poor and less than 0.5 but weekly values tend to be better in some weeks at different lead times. For example, start dates of week 8 (July 2), week 12 (July 30), week 13 (August 6), week 14 (August 13), and week15 (August 20) for lead 1 forecast have the highest and best ACC values of 0.71, 0.84, 0.75, 0.72, and 0.65, respectively, which suggest a strong positive relationship between forecast and observation. These values are all significant at 0.01 level while the ACC value of 0.54 in week 11 (July 23) is significant at 0.05 level. High ACC scores were also observed for a few start dates at lead times 2, 3, and 4. The scores generally decreased with increasing lead time (Fig. 4) and the poorest scores were



**Fig. 4** Anomaly Correlation between forecast at different lead times compared with persistence forecast. Topmost thick horizontal grey dotted line indicates ACC values that are statistically significant at 0.01 while the solid grey line represents values that are significant at 0.05 level (Source: Ugbah 2016)

observed in lead 4 forecasts with a few negative correlations. This is consistent with Li and Robertson (2015). A statistical test to determine the level of significance of these values was done using the Statistical Package for Social Sciences (SPSS) software.

Persistence is also a baseline, like mean climatology, used to compare with forecasts in order to determine their quality. The persistence forecast for lead 1 was produced by persisting observation of the present week for the following week’s forecast. The result was then correlated with the forecast at different lead times. It is often said that the long time range involved in subseasonal forecasting has made it difficult for it to beat Persistence forecast (Vitart 2014) but result from this study has proven otherwise as the forecast at the different lead times beat persistence in most of the weeks This approach according to Jolliffe and Stephenson (2003) only performs well for short range forecast, but result from this work support the view that it can also perform well for medium ranged forecast as shown (Fig. 4).

**Comparison Between Observed and Forecast during El Nino and La Nina Years**

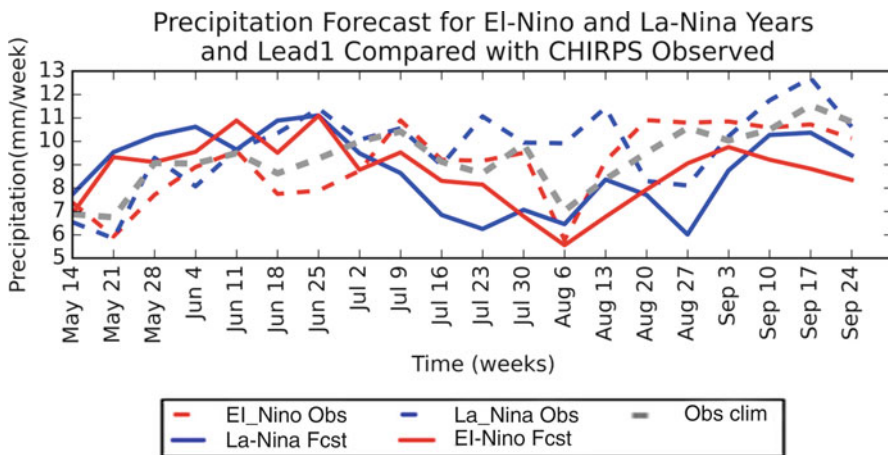
ENSO and MJO both interact in modulating subseasonal to seasonal precipitation. It is assumed that since the ECMWF model is known for its high skill in simulating MJO events, it is also likely to accurately simulate subseasonal rainfall variability during different phases of ENSO. Based on this, it will be good to look at how the model forecast for precipitation during El Nino and La Nina years either agree or differ from the lead 1 forecast for the 1995–2015 period. Only lead one forecast is chosen because it shows the least bias with observed climatology compared to lead times of two, three, and four weeks. El Nino and La Nina years were identified using the Oceanic Nino Index (ONI) as earlier discussed. Four La-Nina (1998, 1999, 2000, 2010) and Five

El-Nino events (1997, 2002, 2004, 2009, 2015) were identified and the forecast for these years extracted and plotted for comparison. The selection of 1997 El Nino and 1999 La Nina events is in agreement with Enso events between 1963–1999 identified by Joly and Voiltoire (2009). The strength of ENSO usually weakens towards the end of first quarter of the year and reaches maximum strength around December to February (Joly and Voiltoire 2009). A strong African monsoon is linked to La Nina events which are observed in April, May, or June (Joly and Voiltoire 2009).

The result of analysis shows that both La Nina and El Nino years forecast are in reasonable agreement with observed precipitation during the first eight weeks (May14–July2) and show a wetter bias, but begin to show marked differences beyond this period particularly in mid-July and in August (Fig. 5) when the little dry season is usually experienced in the study area.

The differences between them were calculated as bias and compared with the 1995–2015 climatology shown in Table 2.

The seasonal mean biases were all negative suggesting underestimation of precipitation by the model compared to observation and was higher (−0.97) during La Nina years than El Nino (−0.41). The 1995–2015 period as a whole, however, showed lower bias compared to the La Nina years. It is likely that the larger bias might be by chance rather than a certainty. The El Nino years showed better results with the least bias and RMSE. The seasonal mean RMSE in La Nina years was 2.24 compared to El Nino which has 1.84 (Table 2).



**Fig. 5** Precipitation forecast and observation for El Nino and La Nina years for one week lead time compared with observed climatology (Source: Ugbah 2016)

**Table 2** Comparing Lead1 scores for the climatological period, El Nino, and La Nina years

Scores of the ECMWF subseasonal weekly forecast over Southern Nigeria			
Period	1995–2015	El Nino years	La Nina years
BIAS	−0.69	−0.41	−0.97
RMSE	1.63	1.84	2.24

Weekly biases compared were positive during the first 7–8 weeks after which they became negative. This is to say that forecast for both El Niño and La Niña years was over predicted during the initial weeks and under-predicted thereafter. Another observation is that the forecast seem to follow the pattern of climatology rather than observation and was lower than the observed for a greater part of the season. The high bias and RMSE particularly in La Niña years shows that the model might be worst in La Niña years and more reliable in El Niño years as the El Niño forecast tends to agree more with the observation and climatology than forecast during La Niña years. All these still point to the model’s inability to accurately simulate southern Nigeria precipitation and suggest that there is still a missing tele-connection between precipitation in the study area and ENSO that has not yet been properly resolved by the ECMWF model. This, however, does not imply that the model is bad, but requires fine-tuning to correct some of the biases observed in order to improve the quality of the forecast. Such biases could arise from the poor representation of the ENSO, MJO, and precipitation tele-connection within the study area. Another reason could be incorrect parameterization of convection and processes which modulate weather over Nigeria. This can also adjusted to give better results. The timing of ENSO events and the delay in the response of a particular region to an ENSO phase is also an important consideration in simulating the tele-connection between them (Joly and Voilodire 2009). This is because significant tele-connection is sometimes observed during the developing stage of ENSO or during its terminal stage (Joly and Voilodire 2009). All these, still remain a big challenge to many numerical modeling experts trying to simulate tele-connection between ENSO and the West African Monsoon (Joly and Voilodire 2009). The “August break” is well captured by the model forecast with strong agreement during the El Niño years than La Niña. However, the greatest noise is observed during this period (July–August). This again shows that the model can be improved.

### **Performance of the S2S Model Precipitation Forecast During Rainfall Peaks and Period of Little Dry Season**

Should the ECMWF S2S model be able to properly simulate high rainfall amounts and pattern during periods of maximum rainfall within the season, then it will no doubt be a good tool in providing useful information for extreme rainfall disaster preparedness, prevention, and risk reduction. Fortunately, the model is able to properly simulate pattern of rainfall in the region and also identify periods of peak rainfall which mostly occurs in June and September as shown in Figs. 3, 4, and 5. The model is also able to depict the little dry season period which occurs between July and August. Such information is considered useful to planners. But unfortunately the model shows a low skill in simulating rainfall amount especially during the peak rainfall period and the little dry season. This is evident in the large biases observed between last week in June and mid-August at lead time of two, three, and four weeks. The biases and RMSE are however minimal at lead time of one week which is good for early warning purposes and disaster preparedness at least one week before the event happens. The skill is also found to be poor during La Niña years which are notable for high rainfall than El-Niño years in the region. This means that the model is not very skillful in simulating heavy precipitation amounts during



heavy rainfall periods especially at lead times beyond one week. It is however still possible that some adjustment in the model by ECMWF to correct the observed biases could give better and reliable results which would make that ECMWF S2S forecast model a dependable tool for predicting extreme high/low rainfall and thus helpful in adapting and mitigating the effects of climate change in the study area.

---

## Conclusion

Large negative biases and root mean square error which were observed to increase with lead times show that the model generally has a dry bias towards estimating precipitation over the area. The high biases and errors observed during La-Nina, than El-Nino years suggests that the model performs better during El-Nino years. Users should therefore be cautious of its use during La-Nina years. Re-calibrating the model output to reduce these biases is likely to produce better results. Seasonal mean Bias and RMSE which generally increased with increasing lead time during the season showed the best results in the one week lead time and the worst in four weeks lead time. This suggests that the forecast was better at shorter lead time. Seasonal mean ACC values which were generally less than 0.5 but with weekly values greater than 0.7 on certain start dates of the lead 1 and 2 forecast, and lower values for leads 3 and 4 confirm that the forecast is best at lead time of one and two weeks during specific periods in the season than at longer lead times. ECMWF should also consider making some adjustments in the model in aspects of parametrization of ENSO tele-connection with rainfall over the study area to reduce the large biases observed during La Nina years. This is important because La Nina events bring more rains to the region than El Nino events and so the opportunity of more rains and water availability during La Nina years should be maximally exploited through use of good and reliable prediction tools that will provide accurate and reliable information needed for planning by farmers, environmentalist, disaster managers, water resource managers, and policy makers. The results also show that the S2S model precipitation forecast has a skill which is higher than persistence forecast at all the lead times of one to four weeks, thus negating the statement by Vitart (2014) that the long time range involved in subs-seasonal forecasting has made it difficult for it to beat Persistence forecast.

The observed large negative biases and RMSE at lead times of 2, 3, and 4 weeks suggest that the model is not yet very skillful in simulating precipitation amounts over southern Nigeria at longer time ranges; it is, however, very skillful in simulation precipitation amount, pattern, and periods of rainfall peaks/minima during the season at lead time of 1 week. This is evident in the very low biases and errors, thus confirming that the best results were observed for precipitation forecast made with a lead time of one week only. This means that S2S precipitation forecast can provide one week advance signals of periods of peak rainfall, little dry season and expected rainfall amount over southern Nigerians. Such information is considered to be a good early warning and disaster preparedness tool. It could also be a useful tool for planning and decision making if provided at least one week before the event happens. Thus, a way of mitigating and adapting to the effects of climate variability and change is used. The ECMWF S2S can therefore be recommended for this purpose and for updating

seasonal forecast on weekly basis in Nigeria for maximum Agricultural production and for disaster reduction since the skill is high at lead time of one week. It is therefore a good tool for monitoring of rainfall during the rainy season and could still yield better results at longer lead time if the model is further improved by ECMWF.

Future work will expand the scope to cover the entire Nigeria and also assess the skill of the individual ensemble members of the model instead of the average of the ensembles used in this study. Rain gauge observation data will be considered for comparison with forecast. It is also good for work in the future to include determination of rainfall onset, cessation, and length of season using the S2S data instead of looking only at how the model can simulate rainfall amount and pattern as done in this study.

---

## References

- Ayanlade A, Adeoye NO, Babatimehin O (2013) Intra-annual climate variability and malaria transmission in Nigeria. *Bull of Geogr Socio-economic series* 21(21):7–19
- Chai T, Draxler RR (2014) Root mean square error (RMSE) or mean absolute error (MAE)? Arguments against avoiding RMSE in the literature. *Geosci Model Dev* 7:1247–1250
- Chidziezie T, Shrikant C (2010) West African monsoon: is the August break “breaking” in the eastern humid zone of Southern Nigeria? *Climate Change* 103:555–570
- Eludoyin OM, Adelekan IO (2013) The physiologic climate of Nigeria. *Int J Biometeorol* 57:241–264. Springer
- Funk CC, Peterson PJ, Landsfeld MF, Pedreros DH, Verdin JP, Rowland JD, Romero BE, Husak GJ, Michaelsen JC, Verdin AP (2014) A quasi-global precipitation time series for drought monitoring. *US Geol Surv Data Ser* 832:4
- Haiden T, Janousek M, Bauer P, Bidlot J, Ferranti L, Hewson T, Prates F, Richardson DS, Vitart F (2015) Evaluation of ECMWF forecasts, including 2014–2015 upgrades ECMWF Technical Memoranda, No. 765. Available at <http://www.ecmwf.int/sites/default/files/elibrary/2015/15275-evaluation-ecmwf-forecasts-including-2014-2015-upgrades.pdf>. Reading
- Hamill TM (2012) Verification of the TIGGE multimodel and ECMWF reforecast-calibrated probabilistic precipitation forecast over Contiguous United States. *Month Weath Rev* 140:2232–2252
- Hansen JW (2002) Realizing the potential benefits of climate prediction to agriculture: issues, approaches. *Agricultural Systems* 74:309–330
- Inness P, Dorling S (2010) *Operational Weather Forecasting*, Wiley-Blackwell, 231pp
- Intergovernmental Panel on Climate Change (IPCC) 2018 Summary for policymakers. In: Masson-Delmotte V, Zhai P, Pörtner HO, Roberts D, Skea J, Shukla PR, Pirani A, Moufouma-Okia W, Péan C, Pidcock R, Connors S, Matthews JBR, Chen Y, Zhou X, Gomis MI, Lonnoy E, Maycock T, Tignor M, Waterfield T (eds) *Global warming of 1.5°C. An IPCC Special Report on the impacts of global warming of 1.5°C above pre-industrial levels and related global greenhouse gas emission pathways, in the context of strengthening the global response to the threat of climate change, sustainable development, and efforts to eradicate poverty*. In Press
- International Research Institute (IRI) (2016) CHIRPS daily precipitation data. Available at <http://iridl.ideo.columbia.edu/SOURCES/UCSB/.CHIRPS/.v2p0/.daily/global/0p05/index.html?Set-Language=en>
- Jolliffe IT, Stephenson DB (2003) *Forecast verification – a practitioner’s guide in atmospheric science*. Wiley and sons, Chichester, 247pp
- Joly M, Voilidoire A (2009) Influence of ENSO on the west African monsoon: temporal aspects and atmospheric processes. *J Clim* 22:3193–3210
- Li S, Robertson AW (2015) Evolution of submonthly precipitation forecast skill from global ensemble prediction system. *Month Weath Rev* 143:2871–2889

- Maue RN, Langland RH (2014) Northern hemisphere forecast skill during extreme winter weather regimes – a presentation made at the 94th American Meteorological Society annual meeting, Atlanta. Available at [http://www.models.weatherbell.com/news/maue\\_AMS\\_2014.ppt](http://www.models.weatherbell.com/news/maue_AMS_2014.ppt)
- Molteni F, Vitart F, Lang S, Weisheimer A, Keeley S (2016) Sub-seasonal prediction at ECMWF: Present, Past (recent and less recent). Accessed June 2016 [Available at <http://www.ecmwf.int/sites/default/files/elibrary/2015/14495-sub-seasonal-prediction-ecmwf-present-past-recent-and-less-recent-and-future.pdf>]
- NOAA (2016) National Oceanic and Atmospheric Administration Oceanic Nino Index data [available at: [https://origin.cpc.ncep.noaa.gov/products/analysis\\_monitoring/ensostuff/ONI\\_v5.php](https://origin.cpc.ncep.noaa.gov/products/analysis_monitoring/ensostuff/ONI_v5.php)]
- NiMet (2013) Nigerian meteorological Agency: Seasonal Rainfall Prediction Brochure. Available at <http://nimet.gov.ng/sites/default/files/publications/2013-seasonal-rainfall-prediction.pdf>. Abuja
- NiMet (2014) Nigerian meteorological Agency: Seasonal Rainfall Prediction Brochure. Available at <http://www.nimet.gov.ng/sites/default/files/publications/SRP%20BOCHURE%20FINAL.pdf>. Abuja
- Siegmund J et al (2015). Toward a seasonal precipitation prediction system for West Africa: Performance of CFSv2 and high-resolution dynamical downscaling. *J Geoph Res Atm* 120 (15):7316–7339. AGU Publications
- Takaya Y (2015) The sub-seasonal to seasonal (S2S) prediction project. Presentation at World Meteorological Organization workshop held at Pune, India, 9–11 November 2015. Available at [http://www.wmo.int/pages/prog/wcp/wcasp/documents/workshop/pune2015PPT/day1/Session2-Takaya\\_WMO\\_workshop\\_S2S\\_201511.Pdf](http://www.wmo.int/pages/prog/wcp/wcasp/documents/workshop/pune2015PPT/day1/Session2-Takaya_WMO_workshop_S2S_201511.Pdf)
- Ugbah PA (2016) Dissertation: evaluation of European Centre for Medium-range Weather Forecast (ECMWF) subseasonal to seasonal forecast over Nigeria, Department of Meteorology, University of Reading, 44
- Vitart F (2004) Monthly forecasting at ECMWF. *Month Weather Rev* 132(12):2761–2779
- Vitart F (2005) Monthly forecast and the summer 2003 heat wave over Europe: a case study. *Atm Sci Lett* 6:112–117. Wiley publishers
- Vitart F (2014) Evolution of ECMWF sub-seasonal forecast skill scores. *Q J Meteorol Soc* 140:1889–1899. Royal Met Society
- Vitart F, Ardilouze C, Bonet A, Brookshaw A, Chen M, Codorean C, Deque M, Ferranti L, Fucile E, Fuentes M, Hendon H, Hodgson J, Kang H, Kumar A, Lin H, Liu G, Liu X, Malguzzi P, Mallas I, Manoussakis M, Mastrangelo D, MacLachlan C, McLean P, Minami A, Mladek R, Nakazawa T, Najm S, Nie Y, Rixen M, Robertson A, Ruti P, Sun C, Takaya Y, Tolstykh M, Venuti F, Waliser D, Woolnough S, Wu T, Won D, Xiao H, Zaripov R, Zhang L (2016) The Sub-seasonal to Seasonal Prediction (S2S) Project Database. *Bull Amer Meteor Soc* <https://doi.org/10.1175/BAMS-D-16-0017.1>, in press

**Open Access** This chapter is licensed under the terms of the Creative Commons Attribution 4.0 International License (<http://creativecommons.org/licenses/by/4.0/>), which permits use, sharing, adaptation, distribution and reproduction in any medium or format, as long as you give appropriate credit to the original author(s) and the source, provide a link to the Creative Commons license and indicate if changes were made.

The images or other third party material in this chapter are included in the chapter's Creative Commons license, unless indicated otherwise in a credit line to the material. If material is not included in the chapter's Creative Commons license and your intended use is not permitted by statutory regulation or exceeds the permitted use, you will need to obtain permission directly from the copyright holder.





# Agropastoralists' Climate Change Adaptation Strategy Modeling: Software and Coding Method Accuracies for Best-Worst Scaling Data

# 79

Zakou Amadou

## Contents

Introduction .....	1632
Background on BWS .....	1632
Climate Change Policy Identification and Survey Design .....	1633
Data Analysis .....	1633
Results .....	1635
Conclusion .....	1638
References .....	1640

## Abstract

Investigating software and coding method accuracies are still a challenge when dealing with best-worst scaling data. Comparing various climate change policy estimates and their relative importance across different statistical packages has received little attention. In this chapter, we use best-worst scaling approach to determine agropastoralist preferences for 13 climate change adaptation policies across two popular statistical packages (R and SAS). While data were collected from 271 agropastoralists, mixed logit was used to analyze data. Results reveal that mean and standard deviation estimates for 13 climate change adaptation policies from R are higher and statistically significant than SAS estimates. Based on R estimates, prolific animal selection, vaccination, settlement, strategic

This chapter was previously published non-open access with exclusive rights reserved by the Publisher. It has been changed retrospectively to open access under a CC BY 4.0 license and the copyright holder is "The Author(s)". For further details, please see the license information at the end of the chapter.

Z. Amadou (✉)

Faculty of Agricultural Sciences, Department of Rural Economics and Sociology, Tahoua University, Tahoua, Niger

e-mail: [zakouamadou77@gmail.com](mailto:zakouamadou77@gmail.com)

© The Author(s) 2021

W. Leal Filho et al. (eds.), *African Handbook of Climate Change Adaptation*,  
[https://doi.org/10.1007/978-3-030-45106-6\\_129](https://doi.org/10.1007/978-3-030-45106-6_129)

1631

mobility, and strategic destocking are the most popular climate change adaptation policies, and more than two-third of respondents are in favor of these policies.

---

**Keywords**

Climate change adaptation policies · Best-worst scaling · Agropastoralists · Mixed logit models

---

**Introduction**

A myriad of climate change adaptation policies have been proposed to improve farmers and herdsman's resilience building capacity, diversify their income and food, and increase their welfare in a changing climate. Several computation methods have been used to analyze discrete choice and best-worst datasets. While conditional logit, multinomial logit have been widely used in the academic literature, the usage of mixed logit (ML) models has been exploded because it is capable to relax (IIA) and can approximate any random utility model (McFadden and Train 2000).

A recent research has studied mixed logit models: accuracy and software choice by comparing ML across three popular packages, namely, SAS, NLOGIT-LIMDEP, and a user-written add-in module for STATA. Results indicate that the data generating process used was not well suited to evaluate the accuracy of software packages and further research is needed to determine which software is the most accurate (Chang and Lusk 2011).

Another challenge is to determine the climate change adaptation policy, and there are few studies geared at computing welfare effects of individual climate change policy. In addition, determining the relative importance of several climate change policy options can be challenging though they may have the same objective towards resilience building. For instance, prolific animal selection and changing herd composition both aim at reducing herd size and thereby enhancing agropastoralists' resilience build capacity. A third challenge facing researcher is to write an algorithm capable of solving real-life problem.

This chapter contributes to fill a knowledge gap by eliciting agropastoralists preference for alternative climate change policies and also enriching literature related to climate change and choice modeling. While data collected from choice experiment and best-worst have been well-documented, coding methods and algorithm development vary considerably from one statistical package to another.

---

**Background on BWS**

Climate change is increasingly becoming recognized as a global threat and concerted effort such as new climate change adaptation strategies should be undertaken both at local, national, and regional and global levels.

While various government climate change adaptation policies have been proposed to reinforce vulnerable farmers' resilience capacity, little is relatively known about farmers indigenous knowledge related to climate change adaptation strategies. However, not all climate change policies have had expected results on farmers' welfare, and previous studies have indicated that combined government and farmers adaptation strategies are more welfare enhancing (Tabbo et al. 2016).

## Climate Change Policy Identification and Survey Design

Based on previous research and interview with agropastoralists, 13 climate change adaptation policies have been identified and included in this study. To determine the relative importance that agropastoralists place on these policies, a BWS experiment was designed (Marley and Louvriere 2005). A balanced incomplete block design (BIBD) developed by Louviere et al. (2015) has been used to determine allocation of the 13 policies for each BW question. The resulted design contains 13 BWS questions, each having four policy options. The BIBD is the most widely used design in the BWS literature because it is not only a balanced design but also an orthogonal design (Flynn and Marley 2014). Furthermore, the policies were selected to reflect the main issues and challenges recently discussed in climate change adaptation choice as compared to the food choice literature documented by Lusk and McCluskey (2018).

For each BWS question, respondent was asked to select his best and his worst climate change adaptation policies. Figure 1 listed below reports an example of the best-worst questions used in the study.

The coding method used for R is based on position for each pair of best-worst question. The value for the position can be ranged from 1 to 4. For SAS, best options will be assigned 1, worst options (-1), and 0 for non-chosen options. This shows that a scale difference may exist between the two coding methods (Table 1).

## Data Analysis

The BWS approach assumes that respondents simultaneously make repeated choices by choosing the best and worst items in a given set and thereby maximizing the difference (Flynn and Marley 2014). By denoting  $J$  as number of items in each BWS

Best	Endogenous Strategies	Worst
<input type="checkbox"/>	Strategic mobility	<input type="checkbox"/>
<input type="checkbox"/>	Transhumance	<input type="checkbox"/>
<input type="checkbox"/>	Settlement	<input type="checkbox"/>
<input type="checkbox"/>	Income generating income	<input type="checkbox"/>

**Fig. 1** Please select your best and worst endogenous strategies

**Table 1** Climate change adaptation policy and description

Climate change policy	Description
Mutual assistance	Helping agropastoralist to rebuild his herd by donating a gift
Settlement	Combining farming and animal rearing
Strategic mobility	Mobility orientated towards researching forage and water
Strategic destocking	Reducing herd size to accommodate shortage of forage and drought
Prolific animal selection	Keeping animals capable of yielding higher meat and milk products
Sheep and cattle fattening	Increasing sheep and cattle weight by feeding on high concentrate
Vaccination	Treating animal from infectious diseases and producing safe products
Transhumance	Unidirectional movement of the herd in searching of H <sub>2</sub> O and forage
Emergency destocking	Reducing herd size as result of disease's outbreak
Water and soil conservation activities	Aims at increasing food and forage production
Changing herd composition	Keeping only animals that have developed strong resilience
Income generating activities	Undertaking various activities capable of boosting revenue
Forage cultivation	Selecting and growing forage to meet its increasing demand

question (4 climate change adaptation policies), then  $J(J-1)$  best-worst pairs of best-worst choices are possible.

By following this approach, our data were analyzed using random utility framework which is well rooted in microeconomics (McFadden 1974), whereby a given respondent  $n$  derives from the selected best-worst pairs in each BWS question  $t$  is the difference in utility between the  $j$  best and  $k$  worst policies.

This can be mathematically expressed:

$$U_{njt} = \mu_{jt} - \mu_{kt} + \varepsilon_{njt} \quad (1)$$

where  $\mu$  is the vector of estimated importance parameters of the best and worst climate change policies ( $j$  and  $k$  respectively) relative to some policy normalized to zero for identification.

The probability that respondents choose item  $j$  as best and  $k$  as worst out of  $J$  items in BWS question  $t$  is the probability that the difference in utility of the chosen items ( $U_{njt}$  and  $U_{nkt}$ ) is greater than all other  $J(J-1)-1$  possible differences within each BWS question (Lusk and Briggeman 2009). While several econometric methods can be used to model this behavior, mixed logit is the most widely used estimation procedure, because it is flexible and can approximate any random utility model (Train 2009).

The mixed logit model and the probability that an individual  $n$  chooses  $j$  as best and  $k$  as worst can be mathematically written as follows:

$$P_{nij} = \int \mu \prod_{t=1}^T \frac{e^{[\mu_{njt} - \mu_{nkt}]}}{\sum_{l=1}^J \sum_{m=1}^J e^{[\mu_{nlt} - \mu_{nmt}]}} f(\mu_n) d\mu_n \quad (2)$$

where  $f(\mu_n)$  is the density of the importance parameters  $\mu_n$ .

The share of preferences for each climate change adaptation policy can be expressed as follows:

$$\varphi_j = \frac{e^{\mu_j}}{\sum_{k=1}^j e^{\mu_k}} \quad (3)$$

where  $\varphi_j$  is the share of preference for a given climate change adaptation policy.

## Results

Data were collected via well-structured questionnaire delivered to a sample of 271 respondents. Summary statistics and variable definitions are reported in Table 2. Most of the respondents have an average of 40 years and about 76% of respondents were male and 84% of the respondents were married. About 75% of respondents were uneducated, and about 52% and 27% of our sample have an annual income below 90,000 FCFA and between 90,000 and 180,000 FCFA, respectively. In addition, average household size was 8 persons with an average of 16 and 24 respectively for large animal and small animal. About 87% of respondents strongly believe that climate change and environment are correlated.

Table 3 reports estimates from mixed logit models for both R and SAS software. Coefficients reflect the importance of each 12 climate change adaptation policies to forage cultivation, which was normalized to zero for identification purpose. Results show that based on R software estimation, strategic mobility followed by mutual assistance, settlement, strategic destocking, prolific animal selection, sheep and cattle fattening, vaccination, transhumance, emergency destocking, water and soil

**Table 2** Characteristics of surveyed respondents

Variable	Definition	Mean	Standard deviation (SD)
Age	Age in number	40	12
Genre	1 if male, 0 female	0.76	0.42
Marital status	2 if married, 0 otherwise	0.84	0.51
Education	1 uneducated, 0 other	0.25	0.22
<b>Base: Income3</b>	<b>Above 180,000 FCFA</b>	<b>0.00</b>	<b>1</b>
Income1	Below 90,000 FCFA	0.52	0.27
Income2	90,000–180,000 FCFA	0.27	0.52
Family size	Size in numbers	8	5
Large animal size	Size in numbers	16	18
Small animal size	Size in numbers	24	25
Climate and environment	1 if yes	0.87	0.49



**Table 3** Mixed logit models for best-worst scaling data: software and coding method accuracies

R software		SAS software	
Agropastoralists' climate change strategies	Estimate	Agropastoralists' climate change strategies	Estimate
Strategic mobility	0.887*(0.088)	Settlement	0.571*(0.080)
Mutual assistance	0.587*(0.089)	Emergency destocking	0.369*(0.075)
Settlement	0.582*(0.076)	Prolific animal selection	0.347*(0.085)
Strategic destocking	0.528*(0.077)	Water and soil conservation activities	0.299*(0.068)
Prolific animal selection	0.521*(0.072)	Strategic mobility	0.264*(0.067)
Sheep and cattle fattening	0.515*(0.079)	Transhumance	0.214*(0.069)
Vaccination	0.483*(0.071)	Mutual assistance	0.172*(0.073)
Transhumance	0.407*(0.075)	Sheep and cattle fattening	0.080(0.074)
Emergency destocking	0.266*(0.074)	Income generating income	0.052(0.066)
Water and soil conservation activities	0.183*(0.075)	Vaccination	-0.059(0.066)
Changing herd composition	0.181*(0.075)	Strategic destocking	-0.142(0.066)
Income generating activities	0.048(0.079)	Changing herd composition	-0.583(0.079)
Base: Forage cultivation	0.0000	Baseline: Forage cultivation	0.000
<b>Standard deviation estimates</b>		<b>Standard deviation estimates</b>	
Sd.(Strategic mobility)	1.210*(0.161)	Sd.(Settlement)	1.068*(0.153)
Sd.(Mutual assistance)	1.631*(0.163)	Sd.(Emergency destocking)	1.106*(0.148)
Sd.(Settlement)	0.598*(0.191)	Sd.(Prolific animal selection)	1.430*(0.152)
Sd.(Strategic destocking)	0.814*(0.163)	Sd.(Water and soil conservation activities)	0.330(0.251)
Sd.(Prolific animal selection)	0.104(0.522)	Sd.(Strategic mobility)	0.513*(0.201)
Sd.(Sheep and cattle fattening)	0.801*(0.158)	Sd.(Transhumance)	0.549*(0.178)
Sd.(Vaccination)	0.129(0.397)	Sd.(Mutual assistance)	0.935*(0.151)
Sd.(Transhumance)	0.895*(0.155)	Sd.(Sheep and cattle fattening)	1.069*(0.148)
Sd.(Emergency destocking)	0.897(0.153)	Sd.(Income generating activities)	0.044(0.440))
Sd.(Water and soil conservation activities)	0.879*(0.151)	Sd.(Vaccination)	0.338(0.247)
Sd.(Changing herd composition)	0.912*(0.150)	Sd.(Strategic destocking)	0.223(0.374)
Sd.(Income generating activities)	1.210*(0.151)	Sd.(Changing herd composition)	0.974*(0.149)
Log likelihood	-8586.9	-8845	
Numbers of observations(N)	14,612	14,612	
Run time	11 m:22 s	7 m:43 s	

Numbers in parentheses are standard errors, \* denotes mean importance of the policy which is statistically different from forage cultivation, Sd stands for standard deviations

conservation activities, and changing herd composition are the most climate change adaptation policies with a significant difference to forage cultivation. Standard deviation estimates for 12 climate change adaptation policies obtained from R software were statistically and highly significant, implying that heterogeneity is a pattern when analyzing climate policies within the population. Table 2 also reports SAS software estimates. Results reveal that settlement followed by emergency destocking, prolific animal selection, water and soil conservation activities, strategic mobility, transhumance, and mutual assistance are the most important climate change adaptation policies relative to forage cultivation. Results also suggest that standard deviation estimates for settlement, emergency destocking, prolific animal selection, water and soil conservation activities, strategic mobility, transhumance, mutual assistance, sheep and cattle fattening, and changing herd composition are statistically significant, revealing that these estimates do vary in the population and thereby confirming heterogeneity pattern. Heterogeneity pattern when analyzing data in R is higher than heterogeneity pattern with SAS.

Table 3 also shows that R and SAS generated different mean estimates. For instance, the mean estimates for strategic mobility were 0.887 and 0.264 respectively for R and SAS. Similarly, the mean estimates for mutual assistance were 0.587 and 0.172 respectively for R and SAS. The mean estimates for settlement were 0.582 and 0.571 respectively for R and SAS. The mean estimates generated by R are all statistically significant. Similarly, the standard error estimates for strategic mobility, mutual assistance are higher for R than SAS, while standard error estimates for settlement and prolific animal selection are higher for SAS than R. This implies that estimates of standard errors considerably diverge across R and SAS. The standard deviation estimates are generally higher and significant for R than SAS; implying heterogeneity pattern is highly significant for R than SAS. Consequently, R software accurately predicted heterogeneity pattern than SAS.

Table 4 reports share of preferences for R and SAS software estimates. Results show that 12.17%, 9.02%, and 8.97% of respondents viewed strategic mobility, mutual assistance, and settlement as the most desirable climate change adaptation policies, respectively. Based on SAS estimates, 11.63%, 9.51%, and 9.30% of respondents viewed settlement, emergency destocking, and prolific animal selection as the most desirable climate change adaptation policies, respectively. This indicates that share of preference for settlement estimated with SAS is higher than estimate from R. Conversely, share of preference for strategic mobility estimated with R is higher than estimate from SAS. Share of preference for mutual assistance under R is higher than that of SAS. This shows that mixed results prevail while estimating share of preferences under R and SAS. Results also indicate that SAS's algorithm converges faster than that of R.

Table 5 reports the intention to vote for or against each climate change adaptation policy. Results based on R estimation show that more than 70% of respondents would vote for the implementation of policies such as prolific animal selection (100%), vaccination (100%), settlement (84%), strategic mobility (77%), strategic destocking, and sheep and cattle fattening (74%). Forage cultivation (50%) and income generating activities (52%) had the lowest vote share among respondents.

**Table 4** Share of preferences based on R and SAS estimates

	R		SAS
Strategic mobility	12.17%	Settlement	11.63%
Mutual assistance	9.02%	Emergency destocking	9.51%
Settlement	8.97%	Prolific animal selection	9.30%
Strategic destocking	8.50%	Water and soil conservation activities	8.86%
Prolific animal selection	8.44%	Strategic mobility	8.56%
Sheep and cattle fattening	8.39%	Transhumance	8.14%
Vaccination	8.13%	Mutual assistance	7.81%
Transhumance	7.53%	Sheep and cattle fattening	7.12%
Emergency destocking	6.54%	Income generating income	6.92%
Water and soil conservation activities	6.02%	Vaccination	6.20%
Changing herd composition	6.01%	Strategic destocking	5.70%
Income generating activities	5.26%	Changing herd composition	3.67%
Base: Forage cultivation	5.01%	Baseline: Forage cultivation	6.57%

Results based on SAS estimates indicate that more than 70% of respondents would vote the implementation of policies such as income generating activities (88%), water and soil conservation activities (82%), and settlement and strategic mobility (70%). Strategic destocking (26%) and changing herd composition (27%) had the lowest vote share among respondents. Results from Tables 3 and 4 further suggest that concordance between preferences for climate change adaptation policies and voting behavior does exist. Voting implementation results reveal that R and SAS estimates greatly vary.

## Conclusion

A mosaic of climate change adaptation policies have been proposed to build rural household resilience capacity and diversify income and food strategies and improve their livelihood.

This chapter uses BWS approach to elicit Niger agropastoralists preferences for climate change adaptation policies. Using data collected from 271 agropastoralists, results indicate that agropastoralists have a clear preference for settlement, emergency destocking, prolific animal selection, water and soil conservation activities, strategic mobility, transhumance, and mutual assistance. While results also suggest that mean, standard error and standard deviation estimates of these preferences vary across R and SAS package, R package yielded more accurate results than SAS.

Results further suggest that share of preferences and vote for climate change adaptation policy implementation are software package dependent. Future research is to study the stability of climate change adaptation policies overtime. Lusk (2012) stated that public policy is highly interventionist and that policy preferences are more

**Table 5** Agropastoralists' vote for climate change adaptation policy implementation

R software	SAS software					
	Vote for implementation (%)	Vote against implementation (%)	Climate change policy	Vote for implementation (%)	Vote against implementation (%)	
Climate change policy						
Strategic mobility	77	23	Settlement	70	30	
Mutual assistance	64	36	Emergency destocking	63	37	
Settlement	83	17	Prolific animal selection	60	40	
Strategic destocking	74	26	Water and soil conservation activities	82	18	
Prolific animal selection	100	0	Strategic mobility	70	30	
Sheep and cattle fattening	74	26	Transhumance	65	35	
Vaccination	100	0	Mutual assistance	57	43	
Transhumance	67	33	Sheep and cattle fattening	53	47	
Emergency destocking	62	38	Income generating income	88	12	
Water and soil conservation activities	58	42	Vaccination	43	57	
Changing herd composition	58	42	Strategic destocking	26	74	
Income generating income	52	48	Changing herd composition	27	73	
Forage cultivation	50	50	Forage cultivation	50	50	

likely to change external shocks when climate change hit, food safety crisis occurred, and negative externalities happened.

---

## References

- Chang JB, Lusk JL (2011) Mixed logit models: accuracy and software choice. *J Appl Econ* 26:167–172
- Flynn T, Marley T (2014) Best-worst scaling: theory and methods. In: S. Hess and A. Daly (eds), *Handbook of Choice Modelling*. Cheltenham, UK: Edward Elgar 178–201
- Louviere JJ, Flynn TN, Marley AAJ (2015) *Best-worst scaling: theory, methods and applications*. Cambridge University Press, Cambridge
- Lusk JL (2012) The political ideology of food. *Food Policy* 37(5):530–542
- Lusk JL, Briggeman BC (2009) Food Values. *Am J Agric Econ* 91(1):184–196
- Lusk JL, McCluskey J (2018) Understanding the impacts of food consumer choice and food policy outcomes. *Appl Econ Perspect Policy* 40(1):5–21
- Marley AA, Louviere JJ (2005) Some probabilistic models of best, worst, and best-worst choices. *J Math Psychol* 49(6):464–480
- McFadden D (1974) *Conditional logit analysis of qualitative choice behavior*. *Frontiers in Econometrics*. New York: Zarembka
- McFadden D, Train K (2000) Mixed MNL models for discrete response. *J Appl Econ* 15(5):447–470. [https://doi.org/10.1002/1099-1255\(200009/10\)15:5447::AID-JAE5703.0.CO;2-1](https://doi.org/10.1002/1099-1255(200009/10)15:5447::AID-JAE5703.0.CO;2-1)
- Tabbo AM, Amadou Z, Danbaky AB (2016) Evaluating farmers' adaptation strategies to climate change: a case study of Kaou local government area, Tahoua State, Niger Republic. *Jamba: J Disaster Risk Stud* 8(3):a241. <https://doi.org/10.4102/jamba.v8i3.241>
- Train K (2009) *Discrete choice methods with simulation*. Cambridge University Press, Cambridge, UK

**Open Access** This chapter is licensed under the terms of the Creative Commons Attribution 4.0 International License (<http://creativecommons.org/licenses/by/4.0/>), which permits use, sharing, adaptation, distribution and reproduction in any medium or format, as long as you give appropriate credit to the original author(s) and the source, provide a link to the Creative Commons license and indicate if changes were made.

The images or other third party material in this chapter are included in the chapter's Creative Commons license, unless indicated otherwise in a credit line to the material. If material is not included in the chapter's Creative Commons license and your intended use is not permitted by statutory regulation or exceeds the permitted use, you will need to obtain permission directly from the copyright holder.





# Barriers to the Adoption of Improved Cooking Stoves for Rural Resilience and Climate Change Adaptation and Mitigation in Kenya

# 80

Daniel M. Nzengya, Paul Maina Mwari, and Chrociscus Njeru

## Contents

Introduction and Background .....	1642
Literature Review .....	1643
Materials and Methods .....	1645
Results and Discussion .....	1645
Sociodemographic Characteristics of the Sample .....	1645
Source of Energy for Cooking and Perceived Importance of Various Sources by Study Sites .....	1645
Women’s Perceptions of Health Risks Associated with Reliance on Firewood .....	1650
Perceived Future Trends on Use of Various Forms of Energy Sources .....	1651
Perceived Barriers to Adoption of Improved Cooking Stoves .....	1653
Lessons Learned, Study Limitations, and Recommendations for Future Research .....	1657
Conclusion .....	1657
References .....	1657

## Abstract

Majority of Kenya’s citizens reside in the rural areas where wood fuel is still the primary source of energy for cooking. Continuing reliance on wood fuel against the backdrop of burgeoning population poses huge threats to the country’s forest cover, undermining capacity for climate change mitigation and adaptation. This study

This chapter was previously published non-open access with exclusive rights reserved by the Publisher. It has been changed retrospectively to open access under a CC BY 4.0 license and the copyright holder is “The Author(s)”. For further details, please see the license information at the end of the chapter.

D. M. Nzengya (✉)

Department of Social Sciences, St Paul’s University, Limuru, Kenya  
e-mail: [dmuasya@spu.ac.ke](mailto:dmuasya@spu.ac.ke)

P. Maina Mwari · C. Njeru

Faculty of Social Sciences, St Paul’s University, Limuru, Kenya  
e-mail: [mainapaul72@gmail.com](mailto:mainapaul72@gmail.com); [chrocncjeru@gmail.com](mailto:chrocncjeru@gmail.com)

© The Author(s) 2021

W. Leal Filho et al. (eds.), *African Handbook of Climate Change Adaptation*,  
[https://doi.org/10.1007/978-3-030-45106-6\\_133](https://doi.org/10.1007/978-3-030-45106-6_133)

1641

conducted in Machakos and Laikipia counties explored; (i) women's perceptions of the health risks associated with dependence of firewood for cooking, (ii) women's attitudes and perceptions towards improved cooking charcoal stoves (ICS) as cleaner alternatives to traditional firewood stoves for cooking, and (iii) women's perceptions of barriers to adoption of improved cooking stoves. Study findings revealed that women were aware of the health risks associated with the use of firewood for cooking. However, despite these perceptions, upward trends in demands for firewood as a source of energy for cooking in the rural areas may persist in the next coming decades. Barriers to adoption of improved cooking stoves vary by sociocultural contexts. The study concludes that innovations that involve stakeholders especially participatory designs, monitoring, and evaluation of ICS might improve adoption levels. Moreover, innovations to increase adoption need to leverage on the opportunities provided by Sustainable development goal number 7 to accelerate adoption of ICS among other forms of cleaner, affordable, and sustainable sources of energy for cooking.

---

**Keywords**

Improved cooking stoves · Barriers to adoption · Rural resilience · Climate change mitigation · Women · Kenya

---

**Introduction and Background**

Sustainable development goal number seven, target 7.1 challenges the international development community and various governments to work towards achieving universal access to affordable, reliable, and modern energy services by 2030. It is estimated that about three billion people globally rely on biomass and coal burning for domestic use (WHO 2016). Majority of these population resides in developing nations (Clark et al. 2009). The solid biomass fuels available locally are such as wood, charcoal, dung, and agricultural residues for cooking, heating, and other domestic basic needs (Boampong and Phillips 2016). The emissions emanating from these energy sources pose health risks to humanity, among many other negative social and environmental impacts (Dickinson et al. 2015).

Ndegwa and others (2011) posit that 94% of the African rural population and 73% of urban population rely heavily on biomass energy especially for cooking and heating. They further state that wood fuel energy not only used as household energy but also used in schools, hospitals, colleges, small industries, and hotels. Women from rural areas and children below 5 years suffer most from health risks posed by biomass burning during long hours of cooking. The identified drivers of rising demands for wood fuel for cooking include, rapid population growth, inaccessibility to cheaper and affordable alternative energy substitutes, and the rising pervasive poverty and inequality.

Kenya has one of the largest rural populations that still rely on wood fuel as a primary source of energy for cooking. This preliminary study conducted Machakos and Laikipia counties explored; (i) women's perceptions of health risks and the

socioenvironmental consequences associated with dependence of firewood for cooking, (ii) women's attitudes and perceptions towards improved cooking charcoal stoves as cleaner alternatives to traditional firewood stoves for cooking, and (iii) women's perceptions of barriers to adoption of improved cooking stoves by rural households.

---

## Literature Review

Wood fuel is widely used in Kenya's rural areas and urban slums. It accounts for 68% of energy sources in the country with petroleum accounting for 22%, electricity at 9%, and coal at less than 1% (Ndegwa et al. 2011). It is estimated that biomass energy, firewood, charcoal, and agricultural wastes contributes approximately up to 70% of Kenya's energy demand and provides for almost 90% of rural household energy need. Dependence on wood fuel is among the contributors of deforestation exacerbating the country's greenhouse emissions. A study by Marigi (2017) has estimated that typical rural Kenyan family consumes about 11 kg of firewood daily, generating approximately 20.57 kg of carbon dioxide.

There is extensive research showing that traditional cooking stoves that utilize biomass contribute to a wide range of negative impacts on human health, air quality, and climate change. Although many agencies including World Health Organizations (WHO) recommend adoption of ICS in rural settings where cleaner sources of cooking are not available, to reduce indoor pollution, many communities are still challenged with appropriate stove selection, and sustained stove adoption and use. The efforts to better understand and provide solutions to this have faced several challenges. The challenges include matching new technologies with local socioeconomic conditions and cooking culture and designing comprehensive measurement strategies to effectively diagnose success or failure of these improved stoves.

Kenya is one of the countries where a great deal of research has continued to promote the adoption of improved cooking stoves in Kenya. Improved cookstoves have been recommended by many researchers as efficient and effective biomass-fuel stoves that reduce chronic obstructive pulmonary diseases, lung cancer, low birth weight, and premature mortality (Clark et al. 2009). In western Kenya, improved stoves were projected as human health survival especially to the children. The researchers promoted improved cookstove adoptions in the area with a goal to increase human survival through improving air, reducing disease, saving time and money, and reducing environmental degradation. Exposure to indoor air pollution has been blamed to poor human health especially women and both infants and small children who are present near the cooking site. Ezeh and others (2014) noted a 0.8% of neonatal deaths, 42.3% of post-neonatal deaths, and 36.3% of child deaths occurred in household using solid fuels for cooking; 70% of the deaths occurred in rural areas. Some of the promotional strategies in attempt to increase adoption of improved cooking stoves have included linking the prevalence of respiratory-related illness among household members to the indoor pollution associated with the use of firewood. These strategies have advocated for the use of improved cooking



stoves as cleaner alternatives to mitigate indoor pollution, and research designs have revolved around generating empirical evidence to link adoption with improved health outcomes. Pilishvili et al. (2016) work showed that ICS were effective in reducing household air pollution leading to considerable acceptability in rural western Kenya. Also, the work by Silk and others (2012) work sought to increase adoption of locally produced ceramic cookstove in rural Kenyan household. Also, the work by Clark and others (2009) showed positive health impacts among women related to reduced indoor pollution following adoption of ICS.

Other researchers have attempted to leverage on ICS potential benefits of reducing indoor pollution to increase acceptability and adoption. Recent years have embraced much broader advocacy on the wider socioenvironmental benefits of ICS to entice communities' adoption. Jeuland and Pattanayak (2012) have investigated the benefits versus the costs of improved cook stoves in relation to wider implications of variability in health, forest, and climate impacts. The authors argued that adoption of ICS had broader benefits that included health improvement, time saving for households, preservation of forests, and reduction in emissions that contribute to global climate change. The authors concluded that households often find the improved cook stove technology to be inconvenient or culturally inappropriate resulting in disappointing uptake.

Liyama and others contend that ICS reduce deforestation and greenhouse gases that increase global warming leading to climate change. Other researchers who have explored related environmental benefits of ICS adoption include, Kiefer and Bussmann (2008) and Jeuland and Pattanayak (2012). These researchers have evaluated the benefits and costs of ICS on health, forests, and climate impacts, concluding that improved stoves provide improved health and time saving in household, preserve forests and related ecosystem and reduce emissions contributing to global climate change. On the contrary, biomass burning in inefficient cookstoves negatively impact on household level, community and national level, and regional and global level.

Both collecting and combustion of solid fuels used in household levels affects women and girls. Njenga et al. (2017) emphasize that scarcity of firewood forces women and girls to travel long distances looking for the commodity. The authors' claim has become part of the advocacy for improved cookstoves to ensure women could invest time in economically productive activities. Additionally, collecting and carrying is life threatening as women can suffer body injuries, rape, or attacked by wild animals (Njenga et al. 2017). Unsustainable firewood harvesting contributes to forest degradation, further contributing to loss in a nation's carbon sink. According to Loo et al. (2016), demand of biomass fuels is threatening forest cover given the rising demand for the commodity by schools, hotels, industries, among others, hence high emissions leading climate change.

The progress of achieving large-scale adoption and use of ICS has been slow and literature has little information of the slow uptake. Some researchers have contended that cost is not a barrier to adoption pointing that adoption and use of improved stoves is low even when households have given ICS without a charge. A study done in Peru, in 26 villages, only 46% of households used improved stoves given free of

charge (Adrianzén 2010). The findings left the authors puzzled by the difficulties communities faced adopting ICS technologies given the benefits such as reducing household health burden related to indoor air pollution (Ezeh et al. 2014).

---

## Materials and Methods

A questionnaire with open- and closed-ended questions was used to collect data from a sample of 54 women from the rural parts of Laikipia and Machakos County in 2018. In most rural areas in Kenya, cooking is one of the main chores for women. Data collected included energy sources for cooking for households, perceptions of health and environmental problems associated with the use traditional cooking stoves, extent of use of ICS, perceptions of socioenvironmental benefits, perceived importance to a household portfolio of the different sources energy for cooking, individual perceptions related to future trends of the usage of the different sources of energy for cooking, and perceived barriers to the adoption of ICS. Additional questions included sociodemographic information. Descriptive statistics were used to summarize data. Inferential statistics (independent t-test) were used to examine relationships between variables by region.

---

## Results and Discussion

### Sociodemographic Characteristics of the Sample

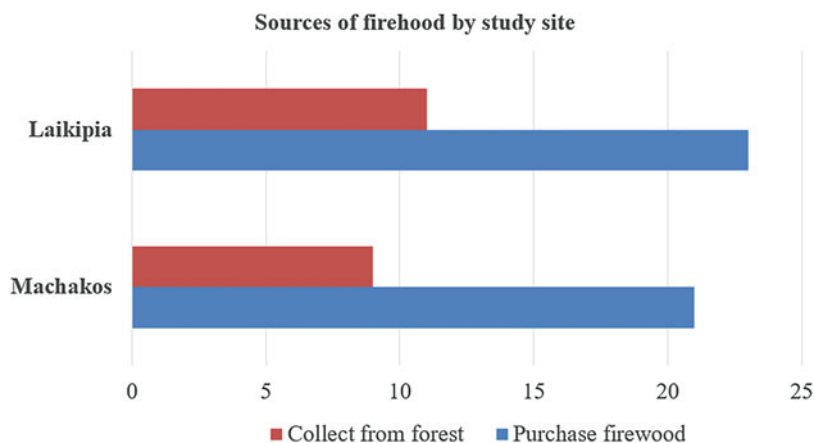
Table 1 below summarizes sociodemographic characteristics of the sample. Majority of the respondents in both counties were aged between 18–29 and 30–59 years. These are the productive age groups in a country and reliance on firewood collection and cooking takes away time that could be invested in productive economic engagements. The average household size for Machakos was 5.77, while that of Laikipia was 4.77. The differences in household size, number of primary school going children, and number of children under 5 years old between Machakos and Laikipia were statistically significant,  $t(52) = 2.45, p < 0.05$ ,  $t(52) = -4.74, p < 0.05$ , and  $t(52) = -6.06, p < 0.05$ , respectively.

### Source of Energy for Cooking and Perceived Importance of Various Sources by Study Sites

Majority of the respondents from the two study areas mentioned relying on both firewood and charcoal for cooking. The researchers further probed sources of energy for cooking. Majority cited that firewood was collected from nearby woodland resources (see Fig. 1). However, majority also mentioned buying both firewood and charcoal. During 1960s, majority of Kenya's rural population probably never imagined of a time when obtaining firewood would cost money, hence purchasing

**Table 1** Sociodemographic characteristics of the sample

Variable	Category	Machakos % (Mean $\pm$ SD)	Laikipia % (Mean $\pm$ SD)
<b>Age</b>	18–29	15	25
	30–59	77	75
	60 or above	8	0
	18–29	15	25
<b>Marital status</b>	Married	77	57
	Single	12	21
	Separated	4	0
	Windowed	8	21
	Married	77	57
Average household size		5.77 $\pm$ 0.54	4.64 $\pm$ 1.72
Average number of school-going children		1.65 $\pm$ 1.9	3 $\pm$ 1.22
Average number of children under 5 years old		0.81 $\pm$ 0.83	2.46 $\pm$ 0.88

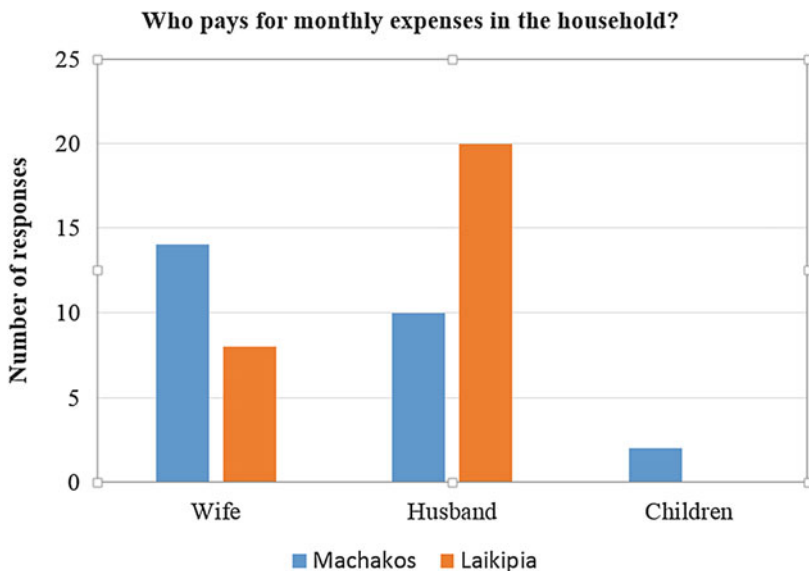
**Fig. 1** Households' sources of firewood. (Source: Survey data)

firewood once regarded an abundant and free resource highlights that over the years sources of firewood have declined to the point that households must purchase the commodity. On average, respondents from Machakos spend 88.5 ( $SD = 20.72$ ) per bundle of firewood, while those from Laikipia spend 237 ( $SD = 50.00$ ) on firewood. On average, respondents from Machakos spend 48.40 ( $SD = 4.95$ ) on charcoal, while those from Laikipia spend 57 ( $SD = 5.39$ ). The differences in households' expenditures on both firewood and charcoal between the two counties were statistically significant,  $t$  ( $df$ ) = 9.97,  $p < 0.05$  (firewood),  $t$  ( $df$ ) = 8.90,  $p < 0.05$  (charcoal). Respondents were asked how much money they spend on a month to meet expenses related to energy for cooking. Results revealed that showed that

on average, households in Machakos spend 2475 ( $SD = 35.54$ ) compared to 875 ( $SD = 144$ ) in Laikipia. The differences in monthly expenditures between the two counties were statistically significant,  $t(df) = 6.67, p < 0.05$ .

Continued reliance on firewood for cooking can be attributed to affordability and availability. In Laikipia, communities have access to adjacent forests for firewood. Moreover, the increase in vendors using motorcycles to ferry firewood further plays role in providing the commodity to households. Mobile vendors make it more convenient for households to save time that would otherwise be spent collecting firewood. It appears from the results obtained that firewood is a little more costly in Laikipia than in Machakos. This is probably because besides cooking, households in Laikipia also use firewood and charcoal for warming the house especially in the evening and during the cold season. It is also probable that most charcoal used in Laikipia is transported from distant sources, unlike in Machakos where residents rely on adjacent counties, Makueni and Kitui for the commodity.

Researchers asked respondents “who in the household was responsible for collecting firewood.” Results obtained showed that women and children were involved in collecting firewood for cooking; however, men were largely involved in the collection and sale of firewood (see Fig. 2). Respondents were asked who in the household was responsible for paying for charcoal and firewood. Machakos, women households were responsible for meeting monthly energy expenses, while in Laikipia, men played that role. Few respondents mentioned children; these are probably elderly women who rely on their children or grandchildren for financial support.



**Fig. 2** Persons in the household responsible for paying household expenses related to energy used

In Laikipia, much of the responsibility of fetching firewood belongs to the wife; according to the findings of this study, it was observed that 78% of household expenses on firewood were done by men. Men in the region are involved more in forest destruction activities that include logging and charcoal burning. Sourcing of firewood and charcoal is expensive and all household budget for it. In Laikipia, majority of husbands play a significant role in meeting household needs mainly because they participate in preparing them (firewood and charcoal), transportation, and in some instances marketing. Another observation is that they buy firewood in larger quantities in form of sacks and large firewood bundles attracting higher value covered by majority of husbands. To some husbands, it is a full-time business.

In Machakos, it appears that the responsibility paying for fuel is perceived as feminine responsibility; majority of respondents at 53.8% admitted that it is the responsibility of the wife, 38.5% said it is husband's responsibility, while only 7.7% said it is the children who pays for fuel expenses.

Several researchers have noted the gendered division of labor when it comes to firewood collection and provisioning at the rural settings. Edelstein et al. (2008) have pointed on the gendered politics of firewood, contending that women have to transverse long distances to gather firewood. The implication is that women spend more time looking for energy sources instead of engaging in productive economic activities. Respondents were asked what other challenges beside increasing scarcity, women encountered when looking for firewood. One challenge that was frequently mentioned were increasing number of conflicts. All respondents from Laikipia reported experiencing conflicts associated with firewood collection. Conflicts over firewood may take a variety of forms, for instance, some sources are as a result of youth in the collection and sale of firewood for income. Other conflicts may be related to emerging rising demand from hotels, schools, small industries, and hospitals.

Table 2 summarizes respondents' perceptions in relation to the importance of various sources of energy for cooking in both Counties. The study observed that the main sources of energy for cooking is firewood and charcoal. This indicates rural population rely on trees for source of energy for cooking and warming, and therefore, there is need for energy saving technologies in both counties.

Results revealed that cow dung is not an important source of energy for cooking in Laikipia (90%) but an important a source of energy for cooking in Machakos (28%). Crop waste is not a source of energy in Laikipia (100%), but somehow a source in Machakos (42%). Due to high rate of population, Machakos may have faced acute deforestation situation, where in some places only cow dung and crop waste are the only source of energy for cooking and warming. Silk et al. (2012) pointed out that where fuel becomes expensive, the disadvantaged population turns to the available cheap ones including plastics.

Findings showed that also saw dust was somehow a source of energy in both counties: Machakos 38%, while Laikipia 17.8%. Kerosene is used for cooking in both counties: Machakos 80.7%, while Laikipia 100%. Kerosene is a common fuel even in rural small towns and can be purchased using <50 shillings. Handling kerosene stoves is easy despite its high production of particulate matter and carbon

**Table 2** Perceived importance various energy sources for cooking by study site

Cooking energy source	Region	Not important (%)	Somewhat important (%)	Very important (%)
Cow dug	Machakos	72	12	16
	Laikipia	90	0	0
Crop waste	Machakos	58	31	12
	Laikipia	100	0	0
Saw dust	Machakos	58	39	4
	Laikipia	36	18	4
Firewood	Machakos	4	<b>35</b>	<b>66</b>
	Laikipia	0	<b>32</b>	<b>68</b>
Charcoal	Machakos	0	<b>39</b>	<b>62</b>
	Laikipia	0	<b>38</b>	<b>61</b>
Kerosene	Machakos	19	58	23
	Laikipia	0	46	54
LPG	Machakos	31	27	42
	Laikipia	0	89	11
Biogas	Machakos	50	46	4
	Laikipia	18	82	0

monoxide which endangers human health. A study by Pilishvili et al. (2016) observed that additional hour of kerosene use was associated with 5% increase in mean kitchen particulate matter. LPG is also a common source of energy in Machakos (69.2) and Laikipia (100%) as well as biogas recording 82.1% in Laikipia and 46.1% in Machakos.

### Cow Dung and Crop Waste

In both regions, cow dung and crop waste according to the research indicate that majority saw it as not important. However, Machakos 16% indicated that it is a very important energy source. Machakos study indicates that some household of study have cleared most of the trees for other development activities. Therefore, the only available cheap fuel source is cow dung and crop waste which contributes high rate of indoor air pollution. This implies that higher health problems on both women and children in Machakos than in Laikipia. In Machakos, over 80% of the households has a cow and they live within the homestead; therefore, the energy source is always available but only preferred in time of extreme need. Promotion of improved cook stove in Machakos started many years back led by Nongovernmental organizations and the government. It therefore implies that majority of homes have an improved stove that easily used dried cow dung to cook. The climate in Machakos favors quick drying of the dung hence less time is needed to prepare it. The fact that 16% noted it as very important implies that the population entirely depends on cow dung for cooking. Use of crop waste is seasonal and fuel energy sources like maize, sorghum, and grass stalks are mainly available after harvest, therefore is an important energy source in Machakos. The pattern shows that those who regard it as very important

are less than those who perceive it as somewhat important. It therefore implies that there is a certain population that entirely depends on crop waste for cooking and this indicates the possibilities of having serious biomass smoke-related health cases in Machakos than in Laikipia (Silk et al. 2012). In Laikipia, cow dung and crop residue are not important at all, since there are other better easily available energy choices. Also, the proximity to the forest enhances accessibility to the energy sources.

### **Kerosene, LPG, and Biogas**

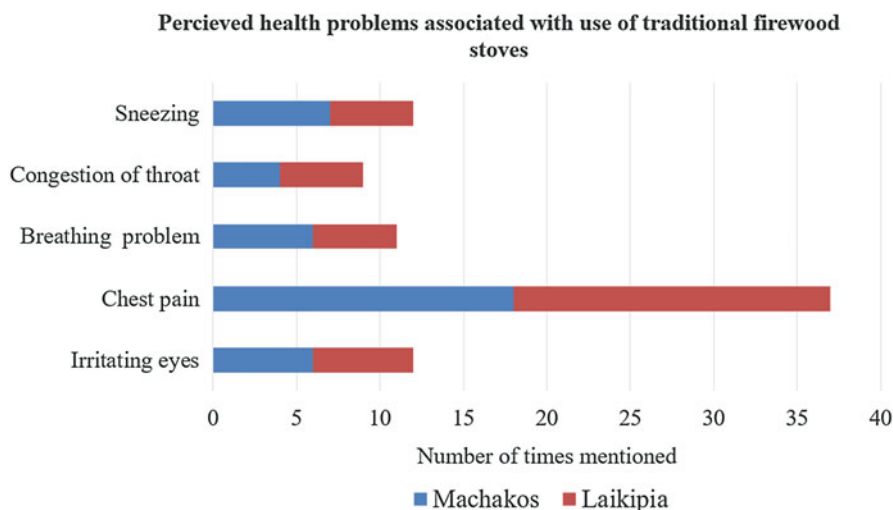
Kerosene as an energy source was noted as more important in Laikipia than in Machakos. This could be attributed to cost and availability since interviewed Laikipia residents seem more sound economically and price determines energy source to use (Silk et al. 2012). Again, one must have a stove designed to use kerosene. This therefore implies increased kerosene related indoor particulate matter pollution according to Pilishvili et al. (2016). In Laikipia, distribution networks for kerosene are more improved than Machakos, hence underlining the product mix concept that states that there is a correlation between products availability and consumption. Few Machakos women (23%) may be relying totally to Kerosene as a source of cooking, while for the rest, kerosene is mostly for light and biomass fuel for cooking. The study is from rural Machakos where few able household use electricity for light. Kerosene for cooking, compared to biomass fuel, is expensive for rural poor households. This could be the reason for low use of kerosene in Machakos.

LPG was noted as very important in Machakos than in Laikipia. However, those who stated as somehow important were at 89% meaning that they consider it necessary but it is not the only solution to energy needs. The price of a product like LPG determines the offering which the customers are willing to give to buy the targeted product. The importance attached to it in Machakos may imply that it is used for major cooking and different affordable packaging sizes in the market attracts many customers. In Laikipia, it seems the energy source LPG is used for light cooking mainly in the morning and late in the evening.

Biogas was noted as very important in Machakos as compared to Laikipia. However, on average, biogas was noted to be used more in Laikipia. This could be attributed by the fact that it requires relative huge investment to establishing a zero-grazing unit.

### **Women's Perceptions of Health Risks Associated with Reliance on Firewood**

Participants were asked to list what they perceived as the health risks associated with the use of traditional firewood stoves for cooking. The lists of mentioned problems were entered in an Excel spreadsheet, and a tally was done to generate a graph summarizing frequently mentioned health risks/illnesses. Results obtained showed that the frequently mentioned health risks, in order of the most to least frequently mentioned health risks included: chest pain, sneezing, irritating eyes, breathing problems, and congestion of throat. Figure 3 summarizes the frequency of mention



**Fig. 3** Perceived health risks associated with the use of firewood traditional stoves for cooking

of the different health risks by respondent study site. Majority of women described chest pain to be a serious health risk. This was consistent across the two study sites. The secondly mostly mentioned health risk was sneezing, again patterns of the number of women describing sneezing problems were consistent across the two study sites. The third most mentioned health risk was eye irritation, and again, patterns of the number of women describing eye irritation problems were consistent across the two study sites. The least frequently mentioned health risk was congestion of throat, and again patterns of the number of women describing congestion of chest problems were consistent across the two study sites. Health risks mentioned can be summarized as respiratory and eye irritation illnesses. All these illnesses are associated with indoor pollution due to smoke and soot emanating from the burning of firewood. ICS are reported reduce indoor pollution related to smoke, and consequently, reduce the illnesses mentioned by the respondents in this study. Where adoption of ICS is challenge, some development agencies have innovated smoke hoods as options for reducing smoke, hence reduced levels of indoor pollution.

### Perceived Future Trends on Use of Various Forms of Energy Sources

Respondents were asked what they perceived to be future trends on use of various forms of energy sources. Table 3 summarizes participants' responses by county. Results showed that almost all the respondents from Laikipia (100%) perceive the use of firewood to remain in the upwards trends (96.4%) compared to 46% from Machakos county. It is unclear what might inform this sort of perceptions. Respondents' perceptions correspond to the expected trends of firewood use in the coming decades, one would anticipate potential decline in negative impacts on forest cover further undermining climate mitigation measures and rural resilience (Njenga et al. 2017).



**Table 3** Perceived future trends on use of various forms of energy sources by study site

Energy source	Region	Falling significantly (%)	Falling slightly (%)	Don't know (%)	Will remain about the same (%)	Rising slightly (%)	Rising significantly (%)
Cow dung	Machakos	54	9	15	4	19	–
	Laikipia	57	14	0	21	7	–
Crop waste	Machakos	46	12	8	19	8	8
	Laikipia	82	0	0	18	0	0
Firewood	Machakos	19	27	4	4	12	35
	Laikipia	0	0	0	0	43	58
Charcoal	Machakos	19	23	–	12	19	27
	Laikipia	0	0	–	4	14	82
Kerosene	Machakos	4	12	–	23	31	31
	Laikipia	0	64	–	32	4	0
LPG	Machakos	–	15	8	–	15	62
	Laikipia	–	0	0	–	61	39
Biogas	Machakos	12	19	2	4	19	23
	Laikipia	0	0	0	18	14	68

Participants from Laikipia, however, anticipate an upward trends in the use of LPG (100%). In addition, majority of respondents from Laikipia (82%) anticipate an upward trend in the adoption of biogas, compared to only 42.3% in Machakos county. LPG provides a capability to prepare meals in a shorter time, especially children's foods (Khadilkar 2015). Market for LPG have continued to provide attractive cylinder sizes affordable to low-income clientele. Also, majority of the women have an appeal for LPG as a clean energy for cooking, especially where mothers are accompanied by their children during cooking. Abundant crop waste, largely wheat and maize to support zero grazing is probably the reason for the perceived rise in biogas adoption in Laikipia.

Respondents from Machakos anticipate an upward trend in the use of kerosene. Besides cooking, kerosene also used for lighting in most rural homes in Machakos. Women overwhelmed with domestic chores prefer lighting a kerosene stove especially for lighter meals. Machakos has limited availability of crop residue and farm-based biomass. In Laikipia, respondents perceive a decline on the future use of kerosene for cooking. It is unclear what might inform this anticipation.

LPG use in Machakos is likely to rise significantly due to the ongoing government subsidy and use of flexible packaging containers. In Machakos, the current generation of population is constructing modern houses which have no kitchens to light firewood or charcoal giving preference to clean energies like LPG and biogas. In both counties, family sizes are becoming smaller with an average of two children, hence demand for heavy cooking will cease with time and demand for clean affordable energy like LPG and biogas will rise.

## Perceived Barriers to Adoption of Improved Cooking Stoves

Respondents were asked on perceived barrier to adopt ICS. Table 4 summarizes responses by county. Results reveal that improved cook stoves are perceived to be costly compared to traditional stove. In both counties, Machakos (57.7%) and Laikipia (57.2) studies, cost was perceived to be a barrier to owning ICS. Some of these cook stoves are unaffordable by rural women especial those with no/little income. Jeuland and Pattanayak (2012) concur with this point when their study argued that women find it expensive to pay for the stove and self-learning of length of time to understand how properly to use the new technology.

Availability of charcoal affects adoption of ICS more in Laikipia (77.6%) than in Machakos (42.3%). The study shows that cost of charcoal affects ICS adoption in Laikipia (96.4%) more than Machakos (42.3%).

Stove design is probably not perceived as barrier in Machakos (34.4%); however, majority of the women from Laikipia (60.7%) seems to suggest design as problem. Stove designs acceptance depends on the provision benefits of cooking styles and needs of a given locality (Khadilkar 2015). Masera et al. (2007) cited the difficult of using some stove design to prepare traditional foods in Mexico. Also accepting a design means being able to use and repair. Therefore, improved cook stove may not be meeting the traditional needs of cooking in Laikipia. Also, low rate of literacy in

**Table 4** Perceived barriers to adoption of improved cooking stoves by study site

Perceived hindrance	Region	Not a hindrance (%)	A little hindrance (%)	Don't have experience with this (%)	Somewhat a hindrance (%)	A very huge hindrance (%)
High cost	Machakos	12	19	12	15	42
	Laikipia	0	43	0	43	14
Availability of charcoal	Machakos	1	27	15	19	23
	Laikipia	18	4	0	68	11
Cost of charcoal	Machakos	15	27	15	15	27
	Laikipia	0	4	0	39	57
Design of stove	Machakos	35	27	8	27	4
	Laikipia	40	0	0	61	0
Availability of stove	Machakos	39	23	0	27	12
	Laikipia	0	0	0	32	68
Takes long to light	Machakos	27	31	8	15	19
	Laikipia	0	61	0	39	0
Takes too long to cook	Machakos	35	19	20	20	8
	Laikipia	0	43	57	0	0

the society may not be receptive of new technology ideas. Improved cook stoves availability is a barrier to own one in Laikipia county (100%), while in Machakos County (38.5%) is not an hinderance. Lighting ICS is not termed as a big issue in ICS ownership in both counties Machakos (30.8%) and Laikipia (60.1%). Cooking food using ICS in Machakos (34.6%) is not a barrier of owning one, but in Laikipia majority (57.1%) reported that they lacked experience of time taken in cooking. Sometimes new technologies are not accepted immediately because of the way users fear to change their behavior of cooking, other stove increase fuel consumption or increase time spend in cooking (Jeuland and Pattanayak 2012).

### **High Cost**

In Machakos, high cost of stoves was noted as a major hindrance at 42% in stoves adoption. Today, due to challenges in livelihood income, every cent spent in a family counts and expenditure is based on priorities like paying school fees and buying food for the family. Possible reason could be that the stoves are never budgeted for and in some cases, it is perceived as luxurious and not a solution to indoor pollution. Most promoters of the stoves ask for prompt payment at once making them unaffordable. As mentioned earlier, domestic costs in Machakos are met by women with little or no support from men. Therefore, even if the stoves are sold at a discounted rate, they will always seem expensive. Also, the rural women may lack adequate information/awareness of benefits of improved cook stoves. ICS promoters in most cases mention short-term benefits such as saving firewood/charcoal but forget long-term benefits such health benefits. With this, concerned population end up missing crucial information especially health problems of children and mothers. The implication is that the adoption rate will be low, and firewood and biomass use continue creating negative impact to the environment.

### **Availability of Charcoal**

This is also a major hindrance when it comes to stoves adoption in Machakos. Even though improved cook stove uses less charcoal, it must be of high quality and size to avoid smoking, and this is a challenge. In Machakos, charcoal is produced illegally, outside Charcoal Producer Association (CPA), hence inadequate in the market. For the last two decades, illegal charcoal production and land for agriculture degraded trees in rural Machakos and affected the availability of charcoal. The concept of demand and supply applies, if charcoal is not adequately available, it becomes expensive.

### **Cost of Charcoal**

The reason for low adoption in Laikipia is noted as the cost of the charcoal at 57%. Possible reasons are due to the existence of other sources of energy which are cleaner and cheaper. Marketing of charcoal in Laikipia is mainly in bags and this to many is a huge cost.

### **Design of the Stove**

In Machakos, the design of the stove was noted as a hindrance. Possible reasons could be the fact that stove design determines efficiency of cooking, size of cooking pot too, and the type of food to cook. Most of ICS are imported to Machakos rural areas and may be

the designs do not meet the cooking needs of Machakos rural women. Again, some improved designs need specialist for repair which require funds when compared with three stone. Further, energy saving stoves are designed to save charcoal use, therefore their efficiency is lower and cannot be compared to the three stone firewood stoves. Stove design also influences the time taken to light the stove. According to the pattern from the research, stove design is a bigger hindrance in Laikipia. Availability of firewood and the need to warm houses during cold season are possible reasons. Improved cook stoves are made of vermiculite stone to reduce heat loss hence they do not warm the houses. The implication is that even if the stoves are acquired, they are never adequately used.

### **Availability of the Stove**

This seems to be a huge hindrance in Laikipia, and the all the interviewees fell in the category of somewhat a hindrance (32%) and some stated it is a very huge hindrance (68%). Marketing of improved stoves is a huge business in the energy sector. Private companies have invested a lot and they need return on investment. Distribution of improved cook stoves is low in regions with adequate energy sources like charcoal and firewood, since few people buy them. This translates to low adoption rate and increased forest destruction to sustain the preferred energy sources.

### **Takes Too Long to Light**

Respondents from Machakos (205%) seem to find the time it takes to light ICS to be problematic. Women engaged in household activities value time management. Due to heavy responsibilities within domestic arena, women are assisted to light stoves by their children. But children may face challenges lighting new designs. The comparison is based on traditional stoves. Lighting an improved stove requires a bit of skills that may be a challenge to the elderly. The problem is exacerbated by a lack of special gel for lighting cook stoves. To hasten lighting ICS, majority of the households use kerosene or old newspapers which adds to the cost/expenses of ICS for a household. The implication is that regular use of the stove does not happen.

### **Takes Too Long to Cook**

Observed responses by study sample from Machakos county might be due to mostly preferred traditional diet in this region. Generally, improved cook stove is meant for light cooking. Quality of charcoal in Machakos is a factor since the best charcoal is from indigenous trees classified as hard wood which is rare in the region. Traditional foods are potentially most preferred due to economic challenges; however, cooking traditional dishes takes relatively longer compared to modern dishes. This has implications since ICS are relatively less used particularly among the elderly women.

---

## Lessons Learned, Study Limitations, and Recommendations for Future Research

Even though access to cheaper sources of firewood continue to diminish, use of firewood for cooking still remains the most accessible form of energy for cooking in Kenya's rural areas. This trend is likely to persist in the next coming decade. Women are aware of the health risks associated with reliance on this source of energy. Given that low adoption of ICS as alternative methods of cooking may persist, there is need for interventions that reduce indoor pollution problems associated with continued reliance on firewood. This study was based on participants sampled from two counties; future research may need to include a representative mix of regional ethnic groups in Kenya. The variability on barriers to adoption highlight the need for a highly contextualized design and production of ICS to enhance adoption in culturally diverse contexts. Future research may need to explore the possibility of participatory design in which members of rural communities participate in designing ICS that appeal to their cultural preferences. This potential can be explored via the technical vocational institutions now almost distributed in every county in Kenya.

---

## Conclusion

Citizens in Kenya's rural areas are aware of the health and negative socio-environmental consequences of relying on traditional unimproved firewood cooking stoves. However, there is still an inertia for continued dependence on firewood in the coming decades. Drivers of the perceived upward trends are a result of interaction of many factors. Barriers for adoption of ICS vary according to cultural taste and perceptions of ICS. Diminishing cheaper sources of firewood due to rapid population growth resulting to subsequent smaller land parcels imply future vulnerabilities by rural households as the cost of purchasing firewood is likely to keep rising, posing additional economic burden to households in terms of money spent purchasing firewood, but also on treatment of illnesses associated with indoor pollution from burning firewood. There is need to promote agroforestry as a potential option for meeting anticipated upward trends in demands for firewood to ensure resilience of rural livelihoods and sustainability of current efforts to improve the forest cover in Kenya.

---

## References

- Adrianzén M (2010) Improved stove adoption, firewood consumption and housewives' health: evidence from the Peruvian Andes. [http://mitsloan.mit.edu/neudc/papers/paper\\_289.pdf](http://mitsloan.mit.edu/neudc/papers/paper_289.pdf). Accessed 12 Dec 2019
- Boampong R, Phillips MA (2016) Renewable energy incentives in Kenya: feed-in-tariffs and rural expansion. University of Florida, Gainesville

- Clark ML, Pell JL, Burch JB, Nelson TL, Robinson MM, Conway S, Bachand AM, Reynolds SJ (2009) Impact of improved cookstoves on indoor air pollution and adverse health effects among Honduran women. *Environ Health Res* 19(5):357–368
- Dickinson KL, Kanyomse E, Piedrahita R, Coffey E, Rivera JJ, Adoctor J, . . . Hayden MH (2015) Research on Emissions, Air quality, Climate, and Cooking Technologies in Northern Ghana (REACTING): study rationale and protocol. *BMC Public Health* 15(1):126
- Edelstein MA, Pitchforth E, Asres G, Silverman M, Kulkarni NS (2008) Awareness of health effects of cooking smoke among women in the Gondar region of Ethiopia. *BMC Int Health Hum Rights* 8:1–7
- Ezeh OK, Agho KE, Dibley MJ, Hall JJ, Page AN (2014) The effect of solid fuel use on childhood mortality in Nigeria: evidence from the 2013 cross-sectional household survey. *Environ Health*. 13:113
- Jeuland MA, Pattanayak SK (2012) Benefits and costs of improved cookstoves: assessing the implications of variability in health, forest and climate impacts. *PLoS One* 7(2):e30338
- Khadilkar PD (2015) Capability approach-based evaluation of a biomass cook-stove design. *Curr Sci* 109(9):1601
- Kiefer S, Bussmann RW (2008) Household energy demand and its challenges for forest management in the Kakamega area, western Kenya. *Ethnobot Res Appl* 6:363–371
- Loo J, Hyseni L, Ouda R, Koske S, Nyagol R, Sadumah I, . . . Stanistreet D (2016) User perspectives of characteristics of improved cookstoves from a field evaluation in Western Kenya. *Int J Environ Res Public Health* 13(2):167
- Marigi SN (2017) A stochastic investigation of solar energy application potential in rural households of Kenya and the associated environmental benefits. *J Geosci Environ Prot* 5(04):1
- Masera O, Edwards R, Arnez CA, Berrueta V, Johnson M, Bracho LR, . . . Smith KR (2007) Impact of Patsari improved cookstoves on indoor air quality in Michoacán, Mexico. *Energy Sustain Dev* 11(2):45–56
- Ndegwa G, Breuer T, Hamhaber J (2011) Woodfuels in Kenya and Rwanda: powering and driving the economy of the rural areas. *Rural* 45(2):26–30
- Njenga M, Mahmoud Y, Mendum R, Iiyama M, Jamnadass R, De Nowina KR, Sundberg C (2017) Quality of charcoal produced using micro gasification and how the new cook stove works in rural Kenya. *Environ Res Lett* 12(9):095001
- Pilishvili T, Loo JD, Schrag S, Stanistreet D, Christensen B, Yip F, . . . Bruce N (2016) Effectiveness of six improved cookstoves in reducing household air pollution and their acceptability in rural Western Kenya. *PLoS One* 11(11):e0165529
- Silk BJ, Sadumah I, Patel MK, Were V, Person B, Harris J, . . . Quick RE (2012) A strategy to increase adoption of locally produced, ceramic cookstoves in rural Kenyan households. *BMC Public Health* 12(1):359
- Osita Kingsley Ezeh, Kingsley Emwinyore Agho, Michael John Dibley, John Joseph Hall, Andrew Nicolas Page, (2014) The effect of solid fuel use on childhood mortality in Nigeria: evidence from the 2013 cross-sectional household survey. *Environmental Health* 13 (1)

**Open Access** This chapter is licensed under the terms of the Creative Commons Attribution 4.0 International License (<http://creativecommons.org/licenses/by/4.0/>), which permits use, sharing, adaptation, distribution and reproduction in any medium or format, as long as you give appropriate credit to the original author(s) and the source, provide a link to the Creative Commons license and indicate if changes were made.

The images or other third party material in this chapter are included in the chapter's Creative Commons license, unless indicated otherwise in a credit line to the material. If material is not included in the chapter's Creative Commons license and your intended use is not permitted by statutory regulation or exceeds the permitted use, you will need to obtain permission directly from the copyright holder.





# Improving Food Security by Adapting and Mitigating Climate Change-Induced Crop Pest: The Novelty of Plant-Organic Sludge in Southern Nigeria

# 81

Chukwudi Nwaogu

## Contents

Introduction .....	1660
Materials and Methods .....	1663
Study Area .....	1663
Experimental Design, Yam Cultivation, and Treatments .....	1666
Soil Sampling and Chemical Properties Analyses .....	1668
Termites Sampling .....	1669
Yam Yields .....	1669
Statistical Analyses .....	1669
Results .....	1670
Soil Chemical Properties .....	1670
Yam Tuber Yield and Termites .....	1670
Discussion .....	1672
Soil Chemical Properties .....	1672
Yam Tuber Yield and Termites .....	1676
Limitations of the Study .....	1676
Conclusion .....	1677
Appendix .....	1677
References .....	1680

This chapter was previously published non-open access with exclusive rights reserved by the Publisher. It has been changed retrospectively to open access under a CC BY 4.0 license and the copyright holder is “The Author(s)”. For further details, please see the license information at the end of the chapter.

C. Nwaogu (✉)

Department of Forest Protection and Entomology, Faculty of Forestry and Wood Sciences, Czech University of Life Sciences, Prague 6-Suchdol, Czech Republic

Department of Environmental Management, Federal University of Technology, Owerri, Nigeria

Department of Ecology, Faculty of Environmental Sciences, Czech University of Life Sciences, Prague 6-Suchdol, Czech Republic

e-mail: [cnwaogu@gmail.com](mailto:cnwaogu@gmail.com)

© The Author(s) 2021

W. Leal Filho et al. (eds.), *African Handbook of Climate Change Adaptation*,  
[https://doi.org/10.1007/978-3-030-45106-6\\_135](https://doi.org/10.1007/978-3-030-45106-6_135)

1659



---

**Abstract**

Climate change is a global issue threatening food security, environmental safety, and human health in tropical and developing countries where people depend mainly on agriculture for their livelihood. Nigeria ranks among the top in the global yam production. It has the largest population in Africa and has been able to secure food for its growing population through food crops especially yam. Unfortunately, the recent increase in termites' colonies due to climate change threatens yam yield. Besides harming man and environment, pesticides are expensive and not easily accessible to control the pests. This prompted a study which aimed at applying a biotrado-cultural approach in controlling the termites, as well as improving soil chemical properties and yam production. The study hypothesized that *Chromolaena odorata* and *Elaeis guineensis* sludge improved soil nutrient and yam yield and consequently decreased termites' outbreak. In a randomized design experiment of five blocks and five replicates, five different treatments including unmanaged (UM), *Vernonia amygdalina* (VA), *Chromolaena odorata* (CO), *Elaeis guineensis* (EG) liquid sludge, and fipronil (FP) were applied in termites-infested agricultural soil. Data were collected and measured on the responses of soil chemical properties, termites, and yam yield to treatments using one-way ANOVA, regression, and multivariate analyses. The result showed that *Chromolaena odorata* (CO) and EG treatments were the best treatments for controlling termites and increase yam production. Termites were successfully controlled in VA and FP treatments, but the control was not commensurate with yam production. The experiment needs to be extended to other locations in the study region. It also requires an intensive and long-term investigation in order to thoroughly understand (i) the influence of climate change on the termites' outbreak, (ii) the extent of termite damage to the crops, (iii) the impacts of climate change and variability on yam yields, (iii) the agricultural and economic benefits of the applied treatments, and (iv) the ecological and human health safety of the treatments.

---

**Keywords**

Climate change · Sustainable agriculture · Soil · Pest management · Termites · *Elaeis guineensis* · *Vernonia amygdalina* · *Chromolaena odorata* · Fipronil · Ikpo-Obibi

---

**Introduction**

Climate change has globally become a serious threat to environment and man especially in the areas of food security and rapid growing population. Though the impacts of climate change have no geographical boundary, yet the countries in sub-Saharan Africa tend to suffer more because of several reasons including socio-economic, political, and ecological factors (Slingo et al. 2005; Kurukulasuriya et al.

2006). The Assessment Reports of the Intergovernmental Panel on Climate Change (IPCC) urged that, even with the predicted climate change scenarios, extreme events may still occur with devastating effects in more vulnerable areas, causing severe long-term food insecurity (Boko et al. 2007; Christensen et al. 2007).

Yam (*Dioscorea* spp.) is a tuber crop which serves as a major staple food for about 34% of the world's population. In comparison to other tuber crops, yam is a vital source of essential minerals including carbohydrates, vitamins, proteins, and dietary fibers (Olajumoke et al. 2012). In 2004, the world's yam production was estimated at about 46.8 million metric tons, and West Africa accounted for more than two-third of this global production (Sartie et al. 2012). Nigeria ranks highest in yam production among the sub-Saharan African countries (CGIAR 2004). Yam is a highly preferred food crop in Nigeria because:

- (i) It is one of the easiest and fastest food to be prepared in different flavor.
- (ii) Yam tubers can be preserved for longer time (4–6 months) at ambient temperature unlike sweet potato (*Ipomoea batatas* L.) and cassava (*Manihot esculenta*). The sustainability of yam as a source of food for every household is high, even during the onset of the rainy season when food tends to be scarce, yam tubers will be available (Loko et al. 2015). Hence, yam is locally referred as “enyi nwa-ogbuanye na’uwu” meaning “the orphan’s salvager in time of famine.”
- (iii) Economically, yam tubers are high sources of income for the indigenous farmers, and this helps to alleviate poverty (Olorede and Alabi 2013).
- (iv) Socio-culturally, yam promotes the social life of the people: several festivals (such as New Yam Festival, Yam title coronation, and marriage) are celebrated by communities, groups, and individuals using yam (Osunde and Orheva 2009).

During cultivation, yam has its tubers buried in the soil which is the habitat of most ant species especially termite. Termite (*Isoptera*) has been described as one of the yam tubers' main destructive fauna (Atu 1993; Loko et al. 2015). Common among the termite species that damage the yams are the *Microtermes*, *Ancistrotermes*, and *Macrotermes* (Loko et al. 2015). The damage consists of feeding and destruction of planted setts of yam (including tubers, leaves, stems), and yam staking materials, as well as release of methane (Zimmerman and Greenberg 1983). Yam tubers to be harvested are sometimes heavily tunneled in termite-infested soil because the *Microtermes* spp. seldom build colonies within tubers and create apparent hollows. In Nigeria, it has been reported that in soils with high termite infestation, farmers lose more than 5 t ha<sup>-1</sup> of yam due to damage by termites (Atu 1993). However, in the tropics and subtropics, termite has been reported as litter decomposer, and a key player in soil formation (Richard et al. 2006; Belyaeva and Tiunov 2010), yet it degrades the soil quality (Devendra et al. 1998).

Globally, the net impact of climate change has been predicted to include increase in pest damage to agricultural resources (Lovett et al. 2005). In tropical Africa

precisely, climate change has crucial role in the striving, reproduction, and crop-destructive ability of the pests by making the environment favorable for them. Due to variations in weather especially rainfall and temperature, termites' outbreak and infestation become acute. Studies have shown that an average annual rainfall and temperature below 100 cm and 27°C, respectively, promote the survival and catastrophic impacts of the pest (Atu 1993; Richard et al. 2006; Belyaeva and Tiunov 2010). Though termites have been reported to be present throughout the year in most tropical countries of Africa (Wood 1995), their agricultural and economic damage tend to be exacerbated during periods of low rainfall (Ahmed et al. 2011). In the study conducted on the potential impact of climate change on termite distribution in Southern Zambia, Ahmed et al. (2011) found that after a drought, the number of pestiferous termite species increased drastically. Similarly, another study, performed in Uganda by Pomeroy (1976), demonstrated that the distribution of termites' mounds was significantly correlated with temperature and that large termite mounds were absent in areas of lower temperature and high rainfall. Kemp (1955) observed that climate was the principal factor determining the distribution of termites in Northeastern Tanganyika (Tanzania). Farmers in Nigeria, Uganda, and Zambia have reiterated that termite problems are more serious now than in the past (Atu 1993; Sekamatte and Okwakol 2007; Sileshi et al. 2009). Damage by the pests is higher during dry periods than in periods of regular rainfall (Logan et al. 1990). The rapid increase in termite damage might also be attributed to climate change-induced drought. For example, in the last two to three decades, drought associated with El Niño episodes has become more intense and widespread in Africa (Harrington and Stork 1995). Many studies have previously established strong nexus among climate change, termites invasion, and damage to agricultural resources (Jones 1990; Kemp 1955; Logan et al. 1990; Nkunika 1998; Bignell and Eggleton 2000; Eggleton et al. 2002; Ahmed and French 2008; Ahmed et al. 2011; Beaudrot et al. 2011; Rouland-Lefèvre 2011; Buczkowski and Bertelsmeier 2017).

Ikpo-Obibi is one of the important yam-producing communities in Nigeria with more than 80% of the population engaging in agriculture. It is pathetic to report the farmers' ordeal with the climate change-induced termites in the process of yam production. Despite the nutritional and socioeconomic benefits of yam, the termites' attack poses great challenge.

In terms of the control measures, most farmers in Africa have attempted the application of different pesticides, yet sustainable solution was never achieved. For example, in Nigeria, some farmers have applied pesticides such as fipronil, aldrin, imidacloprid, chlorpyrifos, sulfuramid, and heptachlor to control the pests by dressing the yam setts and farmlands. The problems of inaccessibility, high costs, human health safety, and ecological effects of these pesticides limit their usage (UNEP 2000; Boonyatumanond et al. 2006; Sánchez-Bayo 2014). The need for a sustainable method of ameliorating this yam pest and to have increased yield became crucial due to higher food demand from the growing population. In other West African country such as Ghana, it was reported that traditional methods (wood ash, cow dung, and aqueous extract of plant residues "dawadawa") have been successfully used to control the yam pests (Asante et al. 2008). The records

about such traditional applications are yet to be found in Nigeria. Therefore, the present study aimed at appraising a new biotrado-cultural approach of coping with the climate change by controlling the termites, improving the soil properties, and increasing yam production using aqueous extract of *E. guineensis*, *V. amygdalina*, and *C. odorata*. The study also compared the impacts of these plant materials on the soil, yam yield, and termites in relation to the result from the fipronil treatment. It is hypothesized that (i) *C. odorata* enriched the soil minerals and increased yam yield by reducing the effects from climate change and the termites; (ii) the attraction of *E. guineensis* sludge to termites makes it an intervening material that reduced the pests' attack on the yam tubers and consequently enhanced the soil organic carbon (Corg); and (iii) *V. amygdalina* and fipronil treatments can successfully control termites but they have high concentrations of trace elements which aggravate the impacts of climate change and exert negative effects on the soil and yam production. Within this context, the following questions were addressed: (a) What are the variations in the concentrations of soil chemical properties, under the different treatments applied, and how significant are these concentrations? (b) Which of the applied treatments and season increased soil essential minerals? (c) Does increase in Corg and rainfall increase yam production? (d) How sustainable is the fipronil application in relation to termites' control, soil fertility, and yam yield? (e) To what extent does the variability in climate influence the termites and their impacts on yam production?

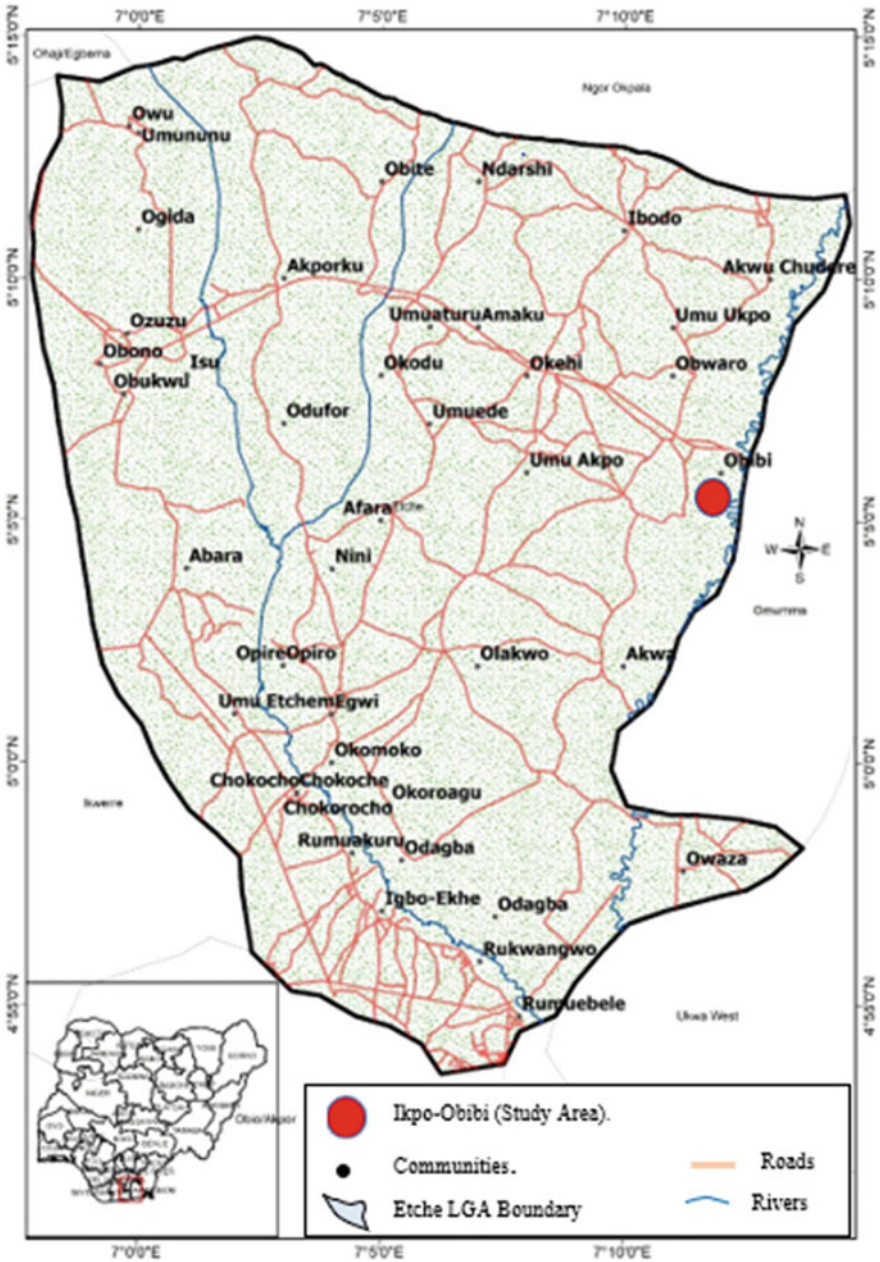
---

## Materials and Methods

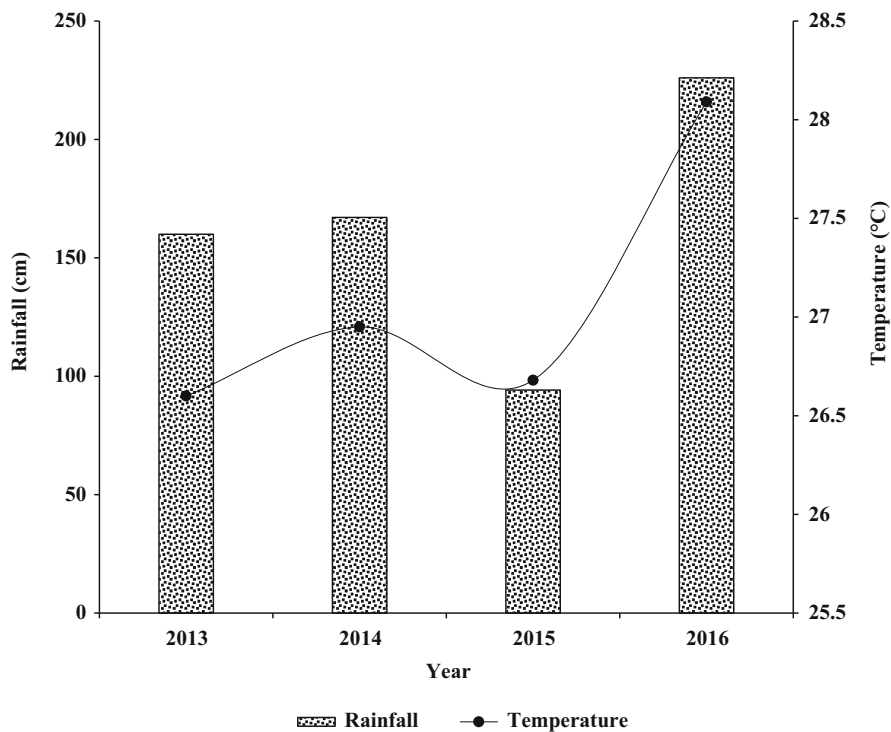
### Study Area

Ikpo is one of the oldest villages among the eight villages in Obibi community in Etche Local Government Area (ELGA) of Rivers State, Nigeria. The farmland is located within latitude  $5^{\circ}06'52.7''\text{N}$  and longitude  $7^{\circ}11'59.4''\text{E}$  (Fig. 1) with an area of about  $52.2 \text{ km}^2$  and a gentle sloping altitude ranging from 50 m to 100 m above sea level. The mean annual rainfall ranges from 100.4 cm to 241.7 cm and mean annual temperature ranging from  $26.5^{\circ}\text{C}$  to  $28.3^{\circ}\text{C}$  (SPDC 1998) (Fig. 2). The study was conducted from 2013 to 2016 under rainfed conditions. The mean monthly rainfall (cm) and temperature ( $^{\circ}\text{C}$ ) of the study site varied (Fig. 2) with 2013 and 2014 indicating normal rainfall years, 2015 revealing a dry year, and 2016 wet year. Though the study area has variations in rainfall that shows a bimodal rainfall distributional trend, yet no month without rainfall. Early-season rain begins in either late January or February and ends in July, and this is categorized as the early growing season. On the other hand, the late-season rain starts in August and ends in December (Nwaogu et al. 2017).

Geologically, the study site lies within Niger Delta Basin, and it is characterized by the Benin or coastal plain sand formation. The age of these formations ranges from Miocene to Eocene.



**Fig. 1** The study area: Ikpo village in Obibi community, Etche LGA of Rivers State, Nigeria



**Fig. 2** Mean annual rainfall and temperature of the study area

The shallow parts of the formations are composed mainly of non-marine sand deposited in alluvial or upper coastal plain (Doust and Omatsola 1990). The soil composition of the study area consisted of fine alluvial content which is an extension of the rich sediments from the River Niger Delta alluvial soil. Presently, the heavy anthropogenic activities (e.g., mining, farming, grazing), pests, and environmental factors have influenced the soil properties (Table 1).

The study area is a typical rainforest region with traces of mangrove and freshwater swamp forests toward the south (Nwankwoala and Nwaogu 2009). There are bushes with trees and shrubs, as well as patches of grasslands dominated by elephant grasses where most farming activities are performed.

There are several termites' mounds which are between 2–7 m high and 2–5 m in diameter that cover the land space forming high termite mound density per hectare. Though the study site has for some years been dominated by termites, the activities of these pests to a large extent depend on climatic conditions. From the growing period to the maturity stage, the termites destroy the development of the crops planted at the site. This at most times leaves the rural farmers with little or nothing to be harvested. At planting and harvesting, five different species of termites were identified as the most common yam-destroying termites: *Amitermes evuncifer*, *Macrotermes bellicosus*, *Microtermes obesi*, *Trinervitermes oconomus*, and *Trinervitermes geminatus* (Atu 1993; Loko et al. 2015).

**Table 1** Soil (0–15 cm depth) chemical and physical properties in the study site prior to the experiment

Soil property	Mean $\pm$ standard error
Corg (mg kg <sup>-1</sup> )	5481 $\pm$ 311
Ntot (mg kg <sup>-1</sup> )	1197 $\pm$ 95
P (mg kg <sup>-1</sup> )	92.6 $\pm$ 23.3
K (mg kg <sup>-1</sup> )	471.1 $\pm$ 37.7
Mg (mg kg <sup>-1</sup> )	334.6 $\pm$ 15.9
Ca (mg kg <sup>-1</sup> )	421.4 $\pm$ 33.4
Fe (mg kg <sup>-1</sup> )	7.8 $\pm$ 1.5
Mn (mg kg <sup>-1</sup> )	6.1 $\pm$ 0.9
Cu (mg kg <sup>-1</sup> )	5.9 $\pm$ 1.2
Zn (mg kg <sup>-1</sup> )	8.8 $\pm$ 1.1
Cr (mg kg <sup>-1</sup> )	5.0 $\pm$ 0.3
pH	6.1 $\pm$ 0.5
Sand (g kg <sup>-1</sup> )	716 $\pm$ 10.4
Silt (g kg <sup>-1</sup> )	118 $\pm$ 6.1
Clay (g kg <sup>-1</sup> )	161 $\pm$ 4.3
Textural class	Sandy-loam
Bulk density (Mg m <sup>-3</sup> )	1.3 $\pm$ 0.1

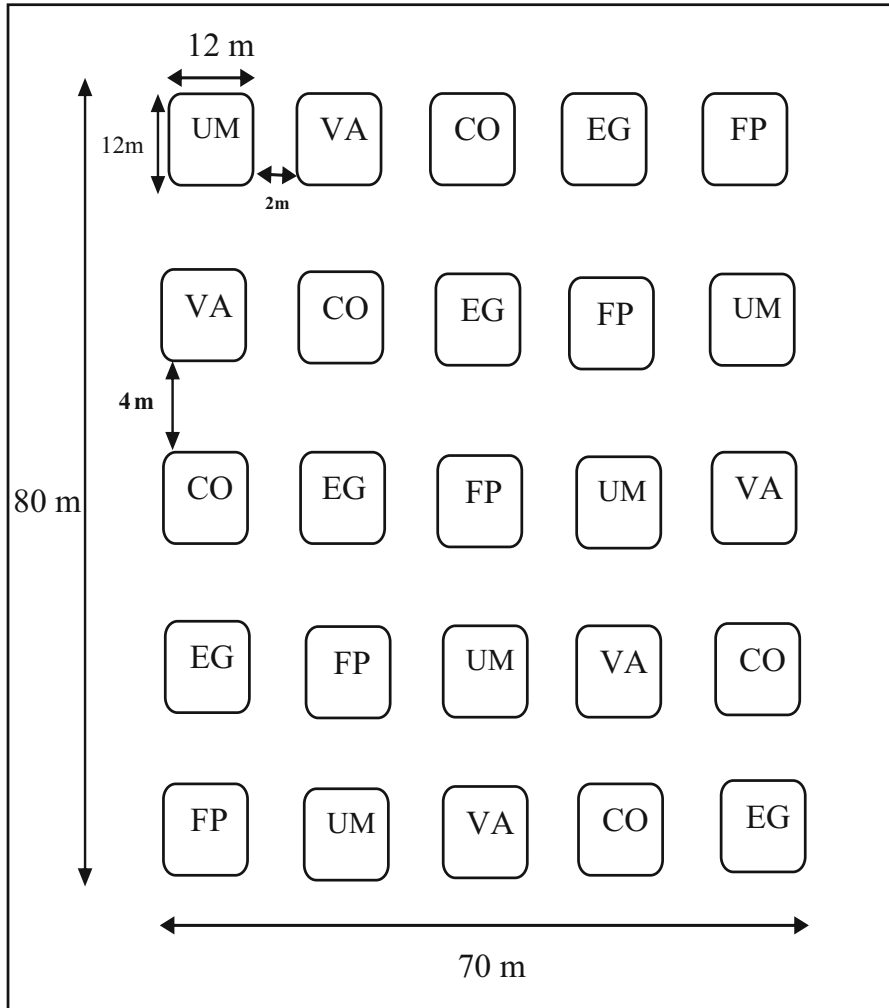
## Experimental Design, Yam Cultivation, and Treatments

The study was conducted in a randomized block design (Fig. 3). The area covered 5,400 m<sup>2</sup> with about 80% of the entire field being used for the yam cultivation and treatments, while the remaining percentage consisted of the borders around the entire treatment plots. Each plot consisted of 144 m<sup>2</sup> (12 m  $\times$  12 m) and was separated by 4 m (column) and 2 m (row) buffer zones. Land preparation for the experiment took place in 2012, and the first phase of the experiment was performed in 4 years (2013–2016) characterized with differences in annual rainfall and temperature. For instance, 2013 and 2014 had a normal rainfall, 2015 was a dry year, and 2016 recorded excess rainfall.

The experimental design includes five blocks, five replicates, five different treatments (UM, unmanaged; VA, *Vernonia amygdalina*; CO, *Chromolaena odorata*; EG, *Elaeis guineensis* liquid sludge; FP, fipronil) (Fig. 3), and their chemical compositions (Table 2).

The land was cleared and the plants' litter removed. Yam planting heaps of 80–100 cm high and 100–120 cm in diameter were prepared every year before the first rainfall of the year. After the first 2–3 rains of the year, yam setts were planted on the prepared heaps/mounds which were at the intervals of 15–20 cm with the cut face placed up (Fig. 4).

Based on the local tradition, the mounds were preferable to the ridges because they promoted easy staking and enhance the production of larger yam tubers when compared with ridges. The VA, CO, and EG treatments were traditionally processed by crushing, soaking in water, and squeezing out the sludge which were stored in 0.7 liter plastics (Appendix Figs. 8, 9, 10, 11, and 12). These were preserved in a cool



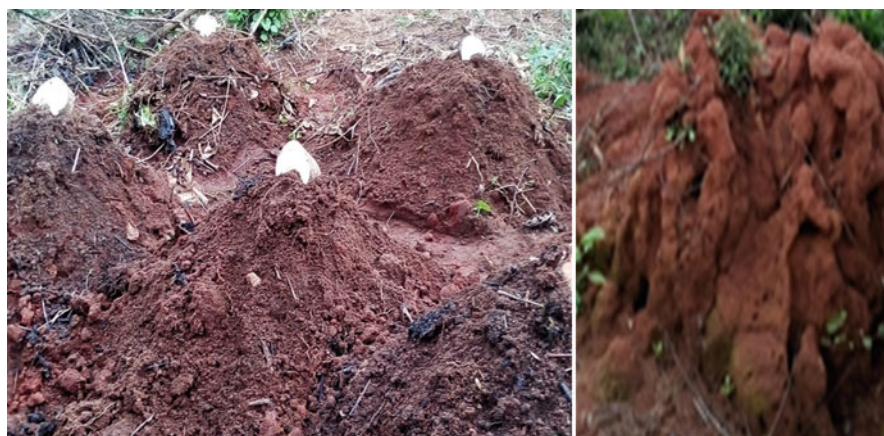
**Fig. 3** Experimental design block for the study. Treatments were UM (unmanaged), VA (*Vernonia amygdalina*), CO (*Chromolaena odorata*), EG (*Elaeis guineensis* liquid sludge), FP (fipronil)

temperature to prevent fermentation before being applied to the yam heaps. On the other hand, the aqueous dilution of fipronil (Fipronil (120068-37-3); Alina Zhao, Ningbo Samreal Chemical Co., Ltd., China) was prepared as prescribed on the product label for termites' control. The prepared treatments were applied by dressing the yam setts. Between 0.2 and 0.3 liters of sludge (or aqueous) were dropped in and around every heap where the yam was planted. This was performed three times (in February/March, August, and November) for each growing season. By using hoes, manual weeding was performed three times (in late May, August, and November) for each growing season. Two stakes, each of 200–300 cm in height,



**Table 2** Mineral and trace element contents ( $\text{mg L}^{-1}$ ) of the organic materials used for the treatments (mean  $\pm$  standard error of the mean)

		Treatment material		
		VA	CO	EG
Minerals	P	83.9 $\pm$ 5.6	116.1 $\pm$ 23.5	154.6 $\pm$ 12.1
	K	52.1 $\pm$ 7.3	181.9 $\pm$ 15.2	271.2 $\pm$ 25.6
	Mg	33.8 $\pm$ 2.9	104.6 $\pm$ 27.7	67.6 $\pm$ 7.3
	Ca	76.4 $\pm$ 11.1	93.3 $\pm$ 12.9	48.7 $\pm$ 2.5
Trace elements	Fe	36.1 $\pm$ 9.7	22.8 $\pm$ 8.1	11.3 $\pm$ 1.0
	Mn	3.3 $\pm$ 0.4	0.4 $\pm$ 0.0	0.3 $\pm$ 0.0
	Cu	5.2 $\pm$ 1.6	0.7 $\pm$ 0.1	0.9 $\pm$ 0.2
	Zn	2.4 $\pm$ 0.7	0.2 $\pm$ 0.0	0.8 $\pm$ 0.3
	Cr	2.3 $\pm$ 0.3	0.1 $\pm$ 0.0	0.2 $\pm$ 0.0

**Fig. 4** Experiment site with yam soil heaps during planting and one of the termites' mounds

were used for staking the yam plants to vine over them – one stake for two plants and the other stake used for bracing the adjacent. Yam tuber harvesting was done in December each year following the local tradition.

### Soil Sampling and Chemical Properties Analyses

In February/March and December, five soil sub-samples (0–15 cm soil depth) from individual treatment plot were randomly collected using a graduated auger. The soil samples were mixed and air-dried; visible pebbles, biomass residues, roots, and other organic debris were removed. Before taken to the laboratory for analysis, the samples were ground in a mortar to pass a 2 mm sieve. All measurements and analyses were performed within 30 days of sampling. The soil pH ( $\text{H}_2\text{O}$ ) was determined by the method of McLean (1982). Organic carbon (Corg) was measured

using the Walkley and Black wet oxidation method (Nelson and Sommers 1996). Total nitrogen (N<sub>tot</sub>) was analyzed using micro-Kjeldahl method (Bremner and Mulvaney 1982). Available P, K, Ca, and Mg were extracted using Mehlich III solution (Mehlich 1984) with reagent and concentrations determined by introducing the inductively coupled plasma-optical emission spectrometry (ICP-OES: 720 Series, Agilent Technologies, USA). On the other hand, the concentrations of the trace elements (Cu, Mn, Cr, Fe, Zn) were determined following the Clayton and Tiller (1979) method. The concentrations were further analyzed using ICP-OES analyzer. The mean of five sub-samples from each monitored treatment was used for the statistical analyses.

## Termites Sampling

The number of termites per heap was collected three times per year: in February/ March (during planting), August (during the short break, that is, the August rainfall break), and December (during harvesting). These periods coincided with the low rainfall months which formed the peak season for the termites' activities (Loko et al. 2015). The termites were observed and counted using the Zoom Handheld Lighted Magnifier Glass (MagniPros 5.5", USA) by randomly selecting the yam heaps and excavating through to the soil profile where the yam tubers could be found. One-third of the heaps were sampled per plot.

## Yam Yields

At physiological maturity, after 9–10 months (that is, in December), the yam tubers were harvested by randomly selecting the yam heaps and excavating through to the soil layers where the yam tubers could be found. One-third of the heaps were sampled per plot. The harvested tubers were washed using water. They were thereafter weighed, and result was recorded in yield per hectares.

## Statistical Analyses

To test the effects of treatments on the soil chemical properties, yam yield, and number of termites, a one-way ANOVA was used. In addition, a repeated-measures ANOVA was applied to deduce the effect of year, treatment, and year x treatment interaction for number of termites, yam yields, soil minerals, and trace elements. The ANOVA was applied after the assumptions of normality were met. Regression analysis was used to test the relationship between yam tuber yield ( $t\ ha^{-1}$ ) and number of termites per yam soil heap. All analyses were conducted using the IBM SPSS Statistics Version 20 (IBM Corporation 2011) ([www.ibm-spss-statistics.soft32.com](http://www.ibm-spss-statistics.soft32.com)) and the STATISTICA 13.0 software (StatSoft, Tulsa, OK, USA), while all data were expressed as means of five replicates.

Furthermore, a multivariate analysis such as redundancy analysis (RDA) followed by a Monte Carlo permutation test with 999 permutations in the Canoco 5.0 software (Šmilauer and Lepš 2014) was used to measure the effect of the different treatments on soil chemical properties during the 4 years. Ordination diagram was produced by using the CanoDraw program software which prompted the presentation and visualization of the RDA results of the experiment.

---

## Results

### Soil Chemical Properties

The concentrations of all the monitored soil chemical properties were significant under the different treatments except for Mn and Cu (Table 3). Most of the measured minerals showed higher concentrations under the CO treatment when compared with VA, EG, UM, and FP treatments. On the other hand, VA and FP treatments had higher trace element concentrations and higher pH when compared with the other treatments. All the essential soil minerals were significantly affected by time and treatment, but not all were affected by the combination of both (i.e., time  $\times$  treatment interaction) (Table 4).

No significant effect of treatment on soil chemical properties calculated by RDA was recorded in 2015 (Table 5). The variability of soil chemical properties explained by treatments subsequently increased from the initially 24% in 2013 to more than 25% in 2014 and more than 50% in 2016. Variability explained by treatments was constantly above 20% between 2013 and 2016.

The treatments were categorized into three different groups in relation to the concentrations of soil chemical properties as were revealed by the ordination diagram (Fig. 5). Based on the RDA analysis of the data collected during the 4 years, CO and EG treatments formed the first group, VA and FP treatments as the second group, and UM treatment as the third group. The relationships between individual soil element and treatment are visible from the ordination diagram (Fig. 5).

### Yam Tuber Yield and Termites

The mean annual yam tuber yields under CO and EG treatments were significant, while UM, VA, and FP treatments never showed any significant differences during the study years (Fig. 6). Year 2015 had the lowest yam tuber yields under the different treatments, while 2013 had the highest.

The results from the total number of termites per yam heap showed that UM and EG treatments were significant at  $P < 0.05$ , while records for VA, CO, and FP treatments revealed no statistical differences in the years (Fig. 7). Year 2015 had the highest number of termites per heap, whereas 2016 had the lowest. The relationships between yam tuber yield and number of termites per heap were negatively significant under the CO and EG, while UM treatment ( $R^2 = 0.50$ ;  $P = 0.045$ ) showed a marginal weak relationship (Table 6).

**Table 3** Mean concentrations ( $\text{mg kg}^{-1}$ ) of soil chemical properties (minerals and trace elements) under the different treatments in 2013–2016. *P*-value represents corresponding probability value. Numbers represent the average of five replicates;  $\pm$  represents standard error of the mean (SEM); significance differences ( $P < 0.05$ ) between treatments in accordance with the Tukey's post hoc test are shown by different letters in the row ( $a < b < c < d < e$ ). Treatment abbreviations (UM, VA, CO, EG, and FP) are described in Fig. 3

	Treatments					F-ratio	P-value
	UM	VA	CO	EG	FP		
<b>Minerals</b>							
Corg	532.6 $\pm$ 106ab	488.1 $\pm$ 211a	708.7 $\pm$ 462d	613.9 $\pm$ 304c	594.1 $\pm$ 84b	21.2	<0.001
Ntot	897.5 $\pm$ 114a	906.6 $\pm$ 12.5a	1815 $\pm$ 93c	1699 $\pm$ 281b	923 $\pm$ 75a	8.5	0.039
P	71.7 $\pm$ 23.5a	98.2 $\pm$ 16.1ab	203.6 $\pm$ 19.9c	117.9 $\pm$ 15.32b	95.8 $\pm$ 11.7ab	0.7	<0.001
K	221.9 $\pm$ 12.2ab	205.1 $\pm$ 5.7a	328.4 $\pm$ 45.3c	239.2 $\pm$ 29.6b	228.0 $\pm$ 15.8ab	5.3	0.027
Mg	341.8 $\pm$ 75.2c	287.9 $\pm$ 73.6b	469.6 $\pm$ 66.5e	413.3 $\pm$ 81.1d	116.3 $\pm$ 28.4a	2.6	<0.001
Ca	432.2 $\pm$ 59.6c	311.4 $\pm$ 54.2b	791.8 $\pm$ 83.7e	609.6 $\pm$ 61.4d	207.1 $\pm$ 19.9a	17.1	<0.001
<b>Trace elements</b>							
Fe	8.1 $\pm$ 1.5a	41.8 $\pm$ 7.3c	24.6 $\pm$ 4.1b	13.0 $\pm$ 1.5ab	52.3 $\pm$ 6.1d	9.1	0.022
Mn	3.1 $\pm$ 0.1	3.9 $\pm$ 0.7	3.4 $\pm$ 0.3	3.8 $\pm$ 0.2	4.2 $\pm$ 0.5	0.4	0.621
Cu	5.3 $\pm$ 0.5	5.1 $\pm$ 0.9	5.5 $\pm$ 1.1	5.6 $\pm$ 1.0	6.7 $\pm$ 1.1	1.8	0.948
Zn	8.3 $\pm$ 1.1b	17.4 $\pm$ 2.5d	6.8 $\pm$ 2.1a	10.3 $\pm$ 2.3c	27 $\pm$ 3.8e	0.9	<0.001
Cr	5.7 $\pm$ 0.3a	25.9 $\pm$ 2.0c	7.1 $\pm$ 1.4ab	9.7 $\pm$ 1.8b	32.1 $\pm$ 3.1d	3.6	0.031
pH	6.0 $\pm$ 0.8a	7.5 $\pm$ 0.2d	6.4 $\pm$ 1.1b	6.9 $\pm$ 0.7c	8.1 $\pm$ 0.8e	0.2	0.043

**Table 4** Results of repeated-measures ANOVA (time, treatment, time  $\times$  treatment) of soil chemical properties, number of termites, and yam yields. df, degree of freedom; F, value derived from F-statistics in repeated-measures ANOVA; and *P*, probability value

	Effect		Effect		Effect	
	Time: df = 4		Treatment: df = 5		Time $\times$ treatment: df = 20	
	<i>F</i> -ratio	<i>P</i> -value	<i>F</i> -ratio	<i>P</i> -value	<i>F</i> -ratio	<i>P</i> -value
Soil chemical properties						
Corg	23.5	*	11.8	*	3.1	*
Ntot	14.1	*	24.3	*	1.8	*
P	3.9	*	5.9	*	0.3	ns
K	3.3	*	17.7	*	0.5	ns
Mg	10.2	*	6.8	*	2.4	*
Ca	9.7	*	18.3	*	1.2	*
Fe	0.6	ns	35.1	*	0.4	ns
Mn	0.9	ns	1.8	ns	0.7	ns
Cu	1.8	ns	0.7	ns	0.5	ns
Zn	31.7	*	11.2	*	2.7	*
Cr	25.5	*	57.1	*	3.1	*
pH	14.1	*	8.5	*	0.5	ns
Number of termites	10.6	*	17.9	*	0.9	ns
Yam yield	37.3	*	22.3	*	1.2	ns

Note: ns, not significant; \*, significant at  $P < 0.05$

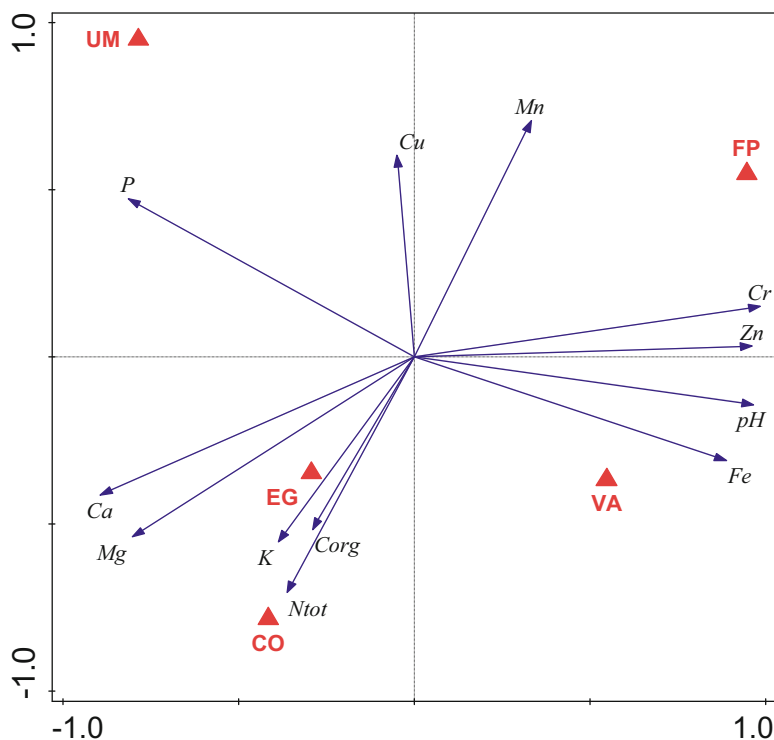
**Table 5** Results of RDA analyses of soil chemical properties estimates performed separately for each year. % explanatory variable, concentrations, variability explained by one (all) ordination axis (measures of explanatory power of the explanatory variables); *F*-ratio, *F*-statistics for the test of analysis; *P*-value, probability value obtained by the Monte Carlo permutation test. Tested hypothesis: there is any effect of treatment on soil chemical properties for each year. Applied treatments were described in Fig. 3

Year	Explanatory variables	% explanatory var. 1st axis (all axes)	<i>F</i> -ratio 1st axis (all axes)	<i>P</i> -value 1st axis (all axes)
2013	UM, VA, CO, EG, FP	11.8 (23.9)	2.4 (1.1)	<0.001 (<0.001)
2014	UM, VA, CO, EG, FP	34.3 (30.7)	8.7 (3.9)	<0.001 (<0.001)
2015	UM, VA, CO, EG, FP	23.6 (21.3)	12.5 (3.6)	<0.31 (0.045)
2016	UM, VA, CO, EG, FP	45.2 (47.8)	11.2 (3.8)	<0.001 (<0.001)

## Discussion

### Soil Chemical Properties

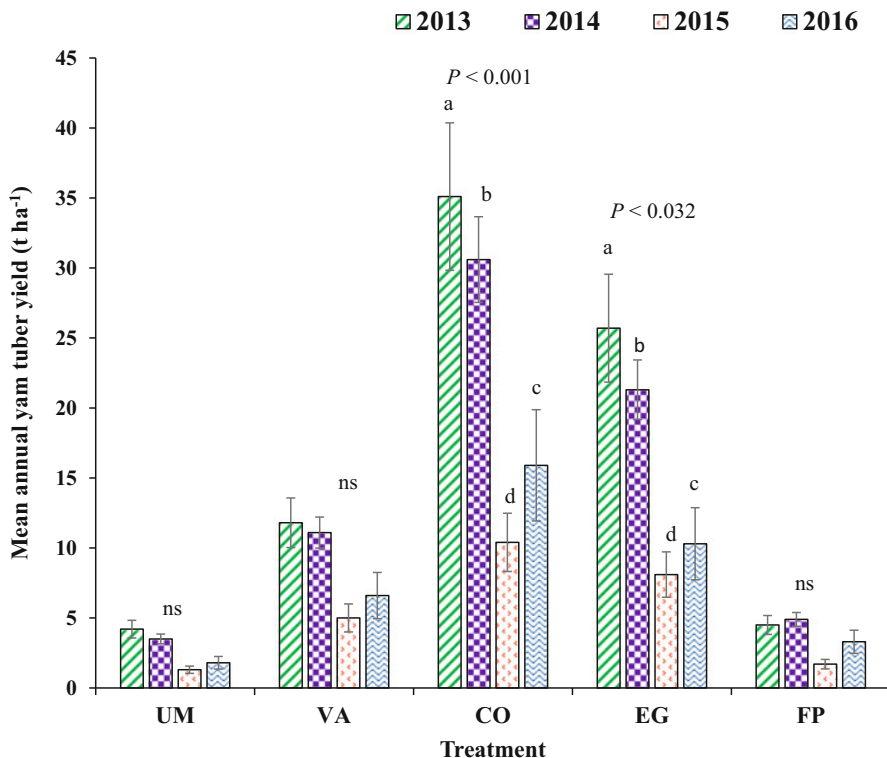
The chemical elements contained in the treatment materials and the prevailing climate substantially influenced the soil chemical properties and consequently exerted significant effects on the different treatments. For example, the



**Fig. 5** Ordination diagram showing result of the RDA analysis of soil chemical properties data collected in 4 years (from 2013 to 2016) in different treatments. Treatment abbreviations are explained in Fig. 3

application of *Vernonia amygdalina* and fipronil (FP) elevated the concentrations of most trace elements in the soil, while *Chromolaena odorata* increased the contents of soil organic carbon and other minerals especially in the favorable climate years. Several studies have reported the effects of the exotic plants and organic residues of *V. amygdalina*, *C. odorata*, and *Elaeis guineensis* on the soil chemical properties and microbes (Kushwaha et al. 1981; Obatolu and Agboola 1993; Quansah et al. 2001; Peveling et al. 2003; Koutika et al. 2004; Callaway et al. 2004; Gbaruko and Friday 2007; Banful and Hauser 2011; Tondoh et al. 2013; Agbede et al. 2014; Gandahi and Hanafi 2014; Nurulita et al. 2014; Ngo-Mbogba et al. 2015; Ajayi et al. 2016; Dawson and Schrama 2016; Veldhuis et al. 2017).

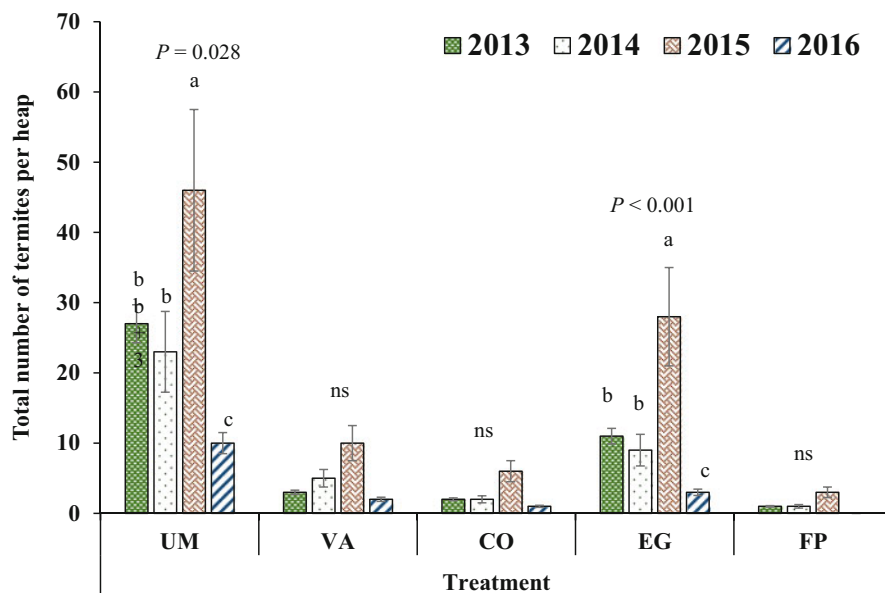
It was discovered in the study that VA and FP treatments recorded relatively high soil pH, and this might be attributed to the high concentrations of the trace elements. This finding was consistent with other studies which have revealed that the elevation of heavy metals in most agricultural soils often leads to soil alkalinity (Nederlof et al. 1993; Lenart and Wolny-Kołodka 2013; Almaroai et al. 2014) and *V. amygdalina* like *Baphia nitida* accumulates high heavy metals in the region (Ogbonna et al. 2013). On



**Fig. 6** Mean annual yam tuber yield ( $\text{t ha}^{-1}$ ). Error bars represent standard error of the mean (SEM).  $P$ -value represents corresponding probability value. *ns* indicates that the results of ANOVA analyses were not significant. Significance differences ( $P < 0.05$ ) between treatments in accordance with the Tukey's post hoc test are shown by lowercase letters (a > b > c > d). Treatment abbreviations were explained in Fig. 3

the contrary, other authors have reported high concentrations of exchangeable Cd and Zn in agricultural soils because of decrease in pH (Sumi et al. 2014).

Although *C. odorata* has been established to be a threat to the soil minerals by some authors (Muniappan et al. 2005), in contrast, several studies in West Africa have positive records about *C. odorata* (Obatolu and Agboola 1993; Goyal et al. 1999; Quansah et al. 2001; Tondoh et al. 2013; Agbede et al. 2014). In agreement with our study, CO treatment revealed increased concentrations of Corg, Ntot, K, and Ca especially in the optimal precipitation years. This might be explained by the deep rooting system of *C. odorata* that mobilizes soil mineral nutrients which are turned into organic and plant-available nutrients in conducive climate (Kushwaha et al. 1981; Tondoh et al. 2013). Other possible reasons for high contents of minerals in the *C. odorata* soil could be due to high contents of leaf biomass and earthworms (Tian et al. 2000; Kone et al. 2012), fast decomposing rate of *C. odorata* (Roder et al. 1995), and the elevated activities of the soil microbes (Mboukou-Kimbasta et al. 2007; Banful and Hauser 2011; Ngo-Mbogba et al. 2015; Dawson and Schrama 2016).



**Fig. 7** Total number of termites (*Isoptera*) per yam soil heap. Error bars represent standard error of the mean (SEM). *P*-value represents corresponding probability value. *ns* indicates that the results of ANOVA analyses were not significant. Significance differences ( $P < 0.05$ ) between treatments in accordance with the Tukey's post hoc test are shown by lowercase letters ( $a > b > c > d$ ). Treatment abbreviations were explained in Fig. 3

**Table 6** Relationships between yam tuber yield ( $\text{kg heap}^{-1}$ ) and number of termites per yam heap for the years under the different treatments

Treatment	Equation	$R^2$	<i>P</i> -value
UM	$Y = -0.0059X + 17.593$	0.50	0.045
VA	$Y = -0.014X + 18.824$	0.21	0.079
CO	$Y = -0.2456X + 35.04$	-0.87	<0.001
EG	$Y = -0.064X + 29.618$	-0.75	0.012
FP	$Y = -0.0128X + 15.53$	0.24	0.063

On the other hand, *E. guineensis* (EG) treatment had elevated soil organic carbon and total nitrogen in our study. This result was consistent with many studies which reported that the oil palm residues promote the scavenging activities of ants which enrich the soil minerals (Frouz et al. 1997; Gandahi and Hanafi 2014; Nurulita et al. 2014; Gray et al. 2015).

No significant effect of treatment on the soil chemical properties was recorded in 2015 as shown by the RDA analysis. The low amount of rainfall recorded in 2015 contributed to the insignificant role of treatments on the soil because the elements from the treatments required enough soil moisture to show reasonable influence on the soil chemistry (Fernelius et al. 2017).



---

## Yam Tuber Yield and Termites

The highest yam tuber yields were found in the CO treatment. This might probably be explained by high Corg, Ntot, P, K, Ca, and Mg in the soil under the CO treatment which consequently increased the crop yield (Obatolu and Agboola 1993; Quansah et al. 2001; Tondoh et al. 2013; Agbede et al. 2014). Similarly, 2013 and 2014 had the highest yam tuber yields across the different treatments. This was attributed to the optimum rainfall in 2013 and 2014 which did not only favor the activities of the microbial organisms but also helped to decrease the number of the termites' attack on the yam tubers. Though the oil palm (EG) liquid sludge attracted more termites in the soil yet, the EG treatment had higher yam tuber yields than UM and VA treatments. This could be because the termites fed more on the oil palm sludge instead of the yam tubers. Besides, the termites' activities improved the soil minerals (Oviasogie and Aghimien 2003; Muhrizal et al. 2006; Guo et al. 2007; Wu et al. 2009).

The total number of termites per yam heap were significant under UM and EG treatments. This was because of the suitability of the unmanaged and *E. guineensis* (EG) treatments which promoted the termites' activities when compared with the VA, CO, and FP treatments that either constrained or killed the ants (Peveling et al. 2003). Though without high yam yields, fipronil application was the easiest method to eradicate the termites from either destroying the yam tubers or carrying out any activities in the yam farmland. But the risk of fipronil on the soil, environment, and human health has been reported by many authors (Keefer and Gold 2014; Sánchez-Bayo 2014; Lopez-Antia et al. 2016).

---

## Limitations of the Study

Some of the limitations for the study are:

- (i) Poor access roads and footpaths to the farm sites where the studies are conducted
- (ii) Destruction of some established experiments by mammals such as rabbits (*Oryctolagus cuniculus*), rats (*Rattus*), grasscutters (*Thryonomys swinderianus*), antelopes (*Bovidae*), and others
- (iii) Ability to convince the rural farmers to give their farmlands for such research because some of the farmers are afraid that their land might be taken by the government or the research institutes
- (iv) Inadequate fund to perform intensive studies: labor, field, laboratory and statistical analyses, and publications
- (v) Dearth of literature on the topic in Nigeria and lack of robust data on the climate and other variables

## Conclusion

Climate change with its variability was found as a factor which has important influence on yam tuber production because (i) the termite colonies increased when there is low rainfall, (ii) the damage caused by the pests exacerbates during dry season than in wet season, and (iii) optimal rainfall enhances soil moisture and promotes the soil microbial activities and decomposition of organic matter which in turn elevates the soil fertility. *Chromolaena odorata* (CO) treatment has been found to be the best single option in managing the termites' infested farmland to increase yam yield. On the other hand, integrating CO and EG treatment is recommended as this might produce higher yield. Though the termites (pests) were successfully reduced under the VA and FP treatments, this reduction was not commensurate with the yam tuber yield. The high content of the trace elements in the VA and FP treatments was attributed to the reason for declined yields because the fipronil is a good soil-binding substance which limits organic decomposition and nutrient cycling. It is also important to state here that a 4-year study is a short term to conclude that *C. odorata* and *E. guineensis* sludge are sustainable for reducing the yam pests (termites) and their harmful activities.

Since climate change is expected to continue locally and globally, this will have further influence on the distribution and intensification of termites which in turn affects agricultural resources. There is crucial need for the effectiveness of termite management strategies which include integrated pest control methods. Furthermore, as most of the termites are soil inhabitants, soil degradation and low rainfall are the main factors promoting their distribution and forage behavior in both tropical and subtropical ecosystems. Thus, there are high chances for aggravated economic devastation of termites' outbreaks in the region due to climate change. Therefore, the experiment needs to be extended to other locations in the study region. It also requires an intensive and long-term investigation in order to thoroughly understand (i) the influence of climate change on the termites' outbreak, (ii) the extent of termite damage to the crops, (iii) the impacts of climate change and variability on yam yields, (iii) the agricultural and economic benefits of the applied treatments, and (iv) the ecological and human health safety of the treatments.

**Acknowledgements** The support from the Department of Forest Protection and Entomology, Faculty of Forestry and Wood Sciences, Czech University of Life Sciences, Czech Republic, and the grants "EVA4.0" No. CZ.02.1.01/0.0/0.0/16\_019/0000803 from the EVA 4.0 project are appreciated.

---

## Appendix

See Figs. 8, 9, 10, 11, and 12.

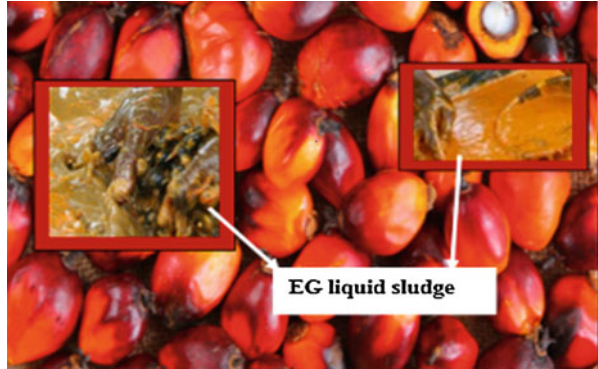
**Fig. 8** Specimen of *Vernonia amygdalina* (VA) used for the experiment



**Fig. 9** Specimen of *Chromolaena odorata* (CO) used for the experiment



**Fig. 10** Specimen of *Elaeis guineensis* (EG) and its liquid sludge used for the experiment



**Fig. 11** Processing of the liquid/sludge of *Vernonia amygdalina* (VA), *Chromolaena odorata* (CO), *Elaeis guineensis* (EG)



**Fig. 12** Stored liquid/sludge of *Vernonia amygdalina*, *Chromolaena odorata*, *Elaeis guineensis* before they were applied in the experiment



## References

- Agbede TM, Adekiya AO, Ogeh JS (2014) Response of soil properties and yam yield to *Chromolaena odorata* (Asteraceae) and *Tithonia diversifolia* (Asteraceae) mulches. Arch Agron soil sci 60:209–224
- Ahmed BM, French JRJ (2008) An overview of termite control methods in Australia and their link to aspects of termite biology and ecology. Pak. Entomol 30:1–18
- Ahmed MB, Nkunika POY, Sileshi GW, French JRJ, Nyeko P, Jain S (2011) Potential impact of climate change on termite distribution in Africa. Br J Environ Climate Chang 1(4):172–189
- Ajayi FT, Omotoso SO, Odejide JO (2016) Evaluation of fodder plants (*Ficus polita*, *Azadirachta indica* and *Vernonia amygdalina*) for their phytochemical and antibacterial properties. Cog. Food Agric 2(1):1211466
- Almaroai YA, Vithanage M, Rajapaksha AU et al (2014) Natural and synthesized iron-rich amendments for As and Pb immobilization in agricultural soil. Chem Ecol 30(3):267–279
- Asante SK, Mensah GWK, Wahaga E (2008) Farmers' knowledge and perceptions of insect pests of yam (*Dioscorea* spp.) and their indigenous control practices in northern Ghana. Ghana J Agric Sci 40(2):185–192
- Atu UG (1993) Cultural practices for the control of termite (*Isoptera*) damage to yams and cassava in south-eastern Nigeria. Intern J Pest Manag 39:462–466
- Banful B, Hauser S (2011) Changes in soil properties and nematode population status under planted and natural fallows in land use systems of southern Cameroon. Agrofor Syst 82:263–273
- Beaudrot L, Du Y, Rahman Kassim A, Rejmanek M, Harrison RD (2011) Do epigeal termite mounds increase the diversity of plant habitats in a tropical rain forest in peninsular Malaysia? PLoS ONE 6(5):e19777
- Belyaeva NV, Tiunov AV (2010) Termites (*Isoptera*) in forest ecosystems of Cat Tien national park (Southern Vietnam). Biol Bullet 37:374–381
- Bignell DE, Eggleton P (2000) Termites in ecosystems. In: Abe T, Bignell DE, Higashi M (eds) Termites: evolution, sociality, symbioses, ecology. Kluwer Academic Publications, Dordrecht, pp 363–387

- Boko MI, Nyong NA, Vogel C, Githeko A, Medany M, Osman-Elasha B, Tabo R, Yanda P (2007) Africa climate change 2007: impacts, adaptation and vulnerability. Contribution of Working Group II to the fourth assessment report of the Intergovernmental Panel on Climate Change, Parry ML, Canziani OF, Palutikof JP, van der Linden PJ, Hanson CE (eds). Cambridge University Press, Cambridge UK, pp 433–467
- Boonyatumanond R, Tabucanon MS, Thongklieng S, Boonchlaermkit S (2006) Persistent of organochlorine pesticides in the green Lip Mussel (*Perna Viridis*) from marine Estuaries in Thailand. *Chem Ecol* 17(1):31–39
- Bremner JS, Mulvaney CS (1982) Nitrogen-total. In: Page AL (ed) Methods of soil analysis no. 9, Part 2, Chemical and microbiological properties. American Society of Agronomy, Madison
- Buczkowski G, Bertelsmeier C (2017) Invasive termites in a changing climate: a global perspective. *Ecol Evol* 7:974–985
- Callaway RM, Thelen GC, Rodriguez A, Holben WE (2004) Soil biota and exotic plant invasion. *Nature* 427:731–733
- Christensen JH, Hewitson B, Busuioac A, Chen A, Gao X, Held I, Jones R, et al (2007) Regional climate projections. Climate change 2007: the physical science basis. Contribution of Working Group I to the Fourth Assessment Report of the Intergovernmental Panel on Climate Change, Solomon S, Qin D, Manning M, Chen Z, Marquis M, Averyt KB, Tignor M, Miller HL, Eds., Cambridge University Press, Cambridge, pp 847–940
- Clayton PM, Tiller KG (1979) A chemical method for the determination of heavy metal content of soils in environmental studies: CSIRO, Australia Melbourne Division. *Soil Technol* 41:1–7
- Consultative Group on International Agricultural Research (CGIAR) (2004) Research and impact: area of research: yam. C:\User\user\Documents\Yam-CGIAR Research & Impact Areas of Research Yam.mh
- Dawson W, Schrama M (2016) Identifying the role of soil microbes in plant invasions. *J Ecol* 104:1211–1218
- Devendra G, Ayo-Odongo J, Kit V, et al (1998) A participatory systems analysis of the termite situation in West Wollega, Oromiya region, Ethiopia. Working document series 68: ICRA/EARO/OADB (Oromia Agricultural Development Bureau), p 168
- Doust H, Omatsola E (1990) Niger delta. In: Edwards JD, Santogrossi I (eds) Divergent and passive margin basins. AAPG Memoir, vol 48: Tulsa, American Association of Petroleum Geologists, Tulsa, pp 201–238
- Eggleton P, Bignell DE, Hauser S, Dibog L, Norgrove L, Madong B (2002) Termite diversity across an anthropological gradient in the humid forest zone of West Africa. *Agric Ecosyst Environ* 90:189–202
- Fernelius KJ, Madsena MD, Hopkins GB et al (2017) Post-fire interactions between soil water repellency, soil fertility and plant growth in soil collected from a burned piñon-juniper woodland. *J Arid Environ* 144:98–109
- Frouz J, Santruckova H, Kalcik J (1997) The effect of wood ants (*Formica polyctena* Foerst.) on the transformation of phosphorus in a spruce plantation. *Pedobiologia* 41:437–447
- Gandahi AW, Hanafi MM (2014) Bio-composting oil palm waste for improvement of soil fertility. Part of the Sustainable development and biodiversity book series (SDEB). *Composting Sustain Agric* 3:209–243
- Gbaruko BC, Friday OV (2007) Bioaccumulation of heavy metals in some fauna and flora. *Intern J Environ Sci Technol* 4:197–202
- Goyal S, Chander K, Mundra MC, Kappor KK (1999) Influence of inorganic fertilizers and organic amendments on soil organic matter and soil microbial properties under tropical conditions. *Biol Fert Soil* 29:196–200
- Gray CL, Lewis OT, Chung AYC et al (2015) Riparian reserves within oil palm plantations conserve logged forest leaf litter ant communities and maintain associated scavenging rates. *J Appl Ecol* 52:31–40
- Guo TR, Zhang GP, Zhang YH (2007) Physiological changes in barley plants under combined toxicity of aluminum, copper and cadmium. *Colloids Surf B Biointerfaces* 57:182–188
- Harrington R, Stork NE (eds) (1995) Insects in a changing environment. Academic, London

- IBM Corporation (2011) IBM SPSS statistics for windows, version 20.0. Armonk: IBM Corporation. [www.ibm-spss-statistics.soft32.com](http://www.ibm-spss-statistics.soft32.com)
- Jones JA (1990) Termites, soil fertility and carbon cycling in dry tropical Africa: a hypothesis. *J Trop Ecol* 6:291–305
- Keefer CT, Gold RE (2014) Recovery from leachate and soil samples of fipronil at termiticide concentration. *Southwestern Entomol* 39:705–716
- Kemp PB (1955) The termites of North-Eastern Tanaganyika (Tanzania): their distribution and biology. *Bull Entomol Res* 46:113–135
- Kone AW, Edoukou EF, Gonnety JT et al (2012) Can the shrub *Chromolaena odorata* (Asteraceae) be considered as improving soil biology and plant nutrient availability? *Agrofor Syst* 85:233–245
- Koutika LS, Hauser S, Meuteum K et al (2004) Comparative study of soil properties under *Chromolaena odorata*, *Pueraria phaseoloides* and *Calliandra calothyrsus*. *Plant Soil* 266:315–323
- Kurukulasuriya P, Mendelsohn R, Hassan R, Benhin J, Deressa T, Diop M, Dinar A et al (2006) Will African agriculture survive climate change? *World Bank Econ Rev* 20:367–388
- Kushwaha SPS, Ramakrishnan PS, Tripathi RS (1981) Population dynamics of *Eupatorium odoratum* in successional environments following slash and burn agriculture. *J Appl Ecol* 18:529–535
- Lenart A, Wolny-Koładka K (2013) The effect of heavy metal concentration and soil pH on the abundance of selected microbial groups within ArcelorMittal Poland Steelworks in Cracow. *Bull Environ Contam Toxicol* 90:85–90
- Logan JWM, Cowie RW, Wood TG (1990) Termite (Isoptera) control in agriculture and forestry by nonchemical methods: a review. *Bull Entomol Res* 80:309–330
- Loko YL, Agre P, Orobisiyi A et al (2015) Farmers' knowledge and perceptions of termites as pests of yam (*Dioscorea spp.*) in Central Benin. *Intern J Pest Manag* 62(1):75–84
- Lopez-Antia A, Feliu J, Camarero PR et al (2016) Risk assessment of pesticide seed treatment for farmland birds using refined field data. *J Appl Ecol* 53:1373–1381
- Lovett JC, Midgley GF, Barnard P (2005) Climate change in Africa. *Afr J Ecol* 43:167–169
- Mboukou-Kimbasta I, Bernhard-Reversat F, Loumeto JN et al (2007) Understorey vegetation, soil structure and soil invertebrates in Congolensis Eucalypt plantations, with special reference to the invasive plant *Chromolaena odorata* and earthworm populations. *Eur J Soil Biol* 47:48–56
- McLean EO (1982) Soil pH and lime requirements. In: Page AL (ed) *Methods of soil analysis. Part 2. Chemical and microbiological properties*, 2nd edn. Agronomy series, 9. ASA, SSSA, Madison
- Mehlich A (1984) Mehlich III soil test extractant: a modification of Mehlich 2 extractant. *Commun Soil Sci Plant Anal* 15:1409–1416
- Muhrizal S, Shamshuddin J, Fauziah I et al (2006) Changes in iron-poor acid sulphate soil upon submergence. *Geoderm* 131:110–122
- Muniappan R, Reddy GVP, Lai PY (2005) Distribution and biological control of *Chromolaena odorata*. In: Inderjit S (ed) *Invasive plants: ecological and agricultural aspects*. Birkhauser Verlag AG, Basel, pp 223–233
- Nederlof MM, Van Riemsdijk WH, De Haan FAM (1993) Effect of pH on the bioavailability of metals in soils. In: Eijssackers HJP, Hamers T (eds) *Integrated soil and sediment research: a basis for proper protection*. Springer, Kluwer Academic Publishers, pp 215–219
- Nelson DW, Sommers LE (1996) Total carbon, organic carbon and organic matter. In: Sparks DL (ed) *Methods of soil analysis. Part 3, 2nd edn. SSSA book series no. 5. ASA and SSSA, Madison*, pp 961–1010
- Ngo-Mbogba M, Yemefack M, Nyeck B (2015) Assessing soil quality under different land cover types within shifting agriculture in South Cameroon. *Soil Tillage Res* 150:124–131
- Nkunika POY (1998) Termite survey, identification, damage and control in southern province. *Land Management and Conservation Farming, Soil Conservation and Agro forestry Extension Report*, Lusaka, Zambia
- Nurulita Y, Adetutu E, Kadali K et al (2014) The assessment of the impact of oil palm and rubber plantations on the biotic and abiotic properties of tropical peat swamp soil in Indonesia. *Int J Agric Sustain* 13(2):150–166

- Nwankwoala HO, Nwaogu C (2009) Utilizing the tool of GIS in oil spill management—a case study of Etche LGA, Rivers State, Nigeria. *Glob J Environ Sci* 8:19–29
- Nwaogu C, Ogbuagu HD, Abrakasa S et al (2017) Assessment of the impacts of municipal solid waste dumps on soils and plants. *Chem Ecol* 33(7):589–606
- Obatolu CR, Agboola AA (1993) The potential of Siam weed (*Chromolaena odorata*) as a source of organic matter for soils in humid tropics. In: Mulongoy M, Merckx R (eds) *Soil organic matter dynamics and sustainability of tropical agriculture*. Wiley-Sayce Co, New York, pp 89–99
- Ogbonna PC, Odukaesime C, Teixeira da Silva JA (2013) Distribution of heavy metals in soil and accumulation in plants at an agricultural area of Umudike, Nigeria. *Chem Ecol* 29(7):595–603
- Olajumoke OL, Agiang MA, Mbeh E (2012) Proximate and anti-nutrient composition of white Guinea yam (*Dioscorea rotundata*) diets consumed in Ibarapa, South West region of Nigeria. *J Nat Prod Plant Resour* 2:256–260
- Oloredo KO, Alabi MA (2013) Economic analysis and modelling of effects of NPK fertilizer levels on yield of yam. *Math Theory Model* 3:108–118
- Osunde ZD, Orhevba BA (2009) Effects of storage conditions and storage period on nutritional and other qualities of stored yam (*Dioscorea spp.*) tubers. *African Journal of Food, Agriculture, Nutr Dev* 9:678–690
- Oviasogie PO, Aghimien AE (2003) Macronutrient status and speciation of Cu, Fe, Zn and Pb in soil containing palm oil mill effluent. *Glob J Pure Appl Sci* 9:71–80
- Peveling R, McWilliam AN, Nagel P et al (2003) Impact of locust control on harvester termites and endemic vertebrate predators in Madagascar. *J Appl Ecol* 40:729–741
- Pomeroy DE (1976) Studies of population of large termite mounds in Uganda. *Ecol Entomol* 1:49–61
- Quansah C, Fening JO, Ampontuah EO et al (2001) Potential of *Chromolaena odorata*, *Panicum maximum* and *Pueraria phaseoloides* as nutrient sources and organic matter amendments for soil fertility maintenance in Ghana. *Biol Agric Hort* 19:101–113
- Richard JF, Ait-Baddi G, Costa C et al (2006) Comparative study of humic acids of the mound of a wood-feeding termite and of the litter directly below in the Amazon river delta. *Chem Ecol* 22(3):201–209
- Roder W, Phengchanh S, Keoboulapha B et al (1995) *Chromolaena odorata* in slash-and-burn rice systems of Northern Laos. *Agrofor Syst* 31:79–92
- Rouland-Lefèvre C (2011) Termites as pests of agriculture. In: Bignell DE et al (eds) *Biology of termites: a modern synthesis*. Springer Science + Business Media B.V, Dordrecht, pp 499–517
- Sánchez-Bayo F (2014) The trouble with neonicotinoids: chronic exposure to widely used insecticides kills bees and many other invertebrates. *Science* 346(6211):806–807
- Sartie A, Franco J, Asiedu R (2012) Phenotypic analysis of tuber yield- and maturity-related traits in white yam (*Dioscorea rotundata*). *Afr J Biotechnol* 1:3964–3975
- Sekamatte MB, Okwakol MJN (2007) The present knowledge on soil pests and pathogens in Uganda. *Afri J Ecol* 45(2):9–19
- Shell Petroleum Development Company of Nigeria Limited (SPDC) (1998) Environmental impact assessment of Obigbo Node associated gas gathering project: final report by Tial Trade Limited, Nigeria
- Sileshi GW, Nyeko P, Nkunika POY, Sekamatte BM, Akinnifesi FK, Ajayi OC (2009) Integrating ethno-ecological and scientific knowledge of termites for sustainable termite management and human welfare in Africa. *Ecol Soc* 14(1):48
- Slingo JM, Challinor AJ, Hoskins BJ, Wheeler TR (2005) Food crops in a changing climate. *Philos Trans R Soc B Biol Sci* 360:1983–1989
- Šmilauer P, Lepš J (2014) *Multivariate analysis of ecological data using CANOCO 5*, 2nd edn. Cambridge University Press, Cambridge
- Sumi H, Kunito T, Ishikawa Y et al (2014) Plant roots influence microbial activities as well as cadmium and zinc fractions in metal-contaminated soil. *Chem Ecol* 31(2):105–110
- Tian G, Kolawole OG, Kang BT et al (2000) Nitrogen fertilizer replacement indexes of legume cover crops in the derived savannah of West Africa. *Plant Soil* 224:287–296
- Tondoh JE, Kone AW, N'Dri JK et al (2013) Changes in soil quality after subsequent establishment of *Chromolaena odorata* fallows in humid savannahs, Ivory Coast. *Catena* 101:99–107



- UNEP (2000) FAO and Global IPM facility expert group on termite biology and management. United Nations Environmental Programme: chemicals finding alternatives to Persistent Organic Pollutants (POPs) for termite management. <http://www.chem.unep.ch/Publications/pdf/Alternatives-termitefulldocument.pdf>
- Veldhuis MP, Laso FJ, Oloff H et al (2017) Termites promote resistance of decomposition to spatiotemporal variability in rainfall. *Ecology* 98:467–477
- Wood TG (1995) The agricultural importance of termites in the tropics. *Agric Zool Rev* 7:117–155
- Wu TY, Mohammad AW, Jahim JM et al (2009) A holistic approach to managing palm oil effluent (POME): Biotechnological advances in the sustainable reuse of POME. *Biotechnol Adv* 27:40–52
- Zimmerman PR, Greenberg JP (1983) Termites and methane. *Nature* 302:354–355

**Open Access** This chapter is licensed under the terms of the Creative Commons Attribution 4.0 International License (<http://creativecommons.org/licenses/by/4.0/>), which permits use, sharing, adaptation, distribution and reproduction in any medium or format, as long as you give appropriate credit to the original author(s) and the source, provide a link to the Creative Commons license and indicate if changes were made.

The images or other third party material in this chapter are included in the chapter's Creative Commons license, unless indicated otherwise in a credit line to the material. If material is not included in the chapter's Creative Commons license and your intended use is not permitted by statutory regulation or exceeds the permitted use, you will need to obtain permission directly from the copyright holder.





# Indigenous and Scientific Forecasts on Climate Change Perceptions of Arable Farmers: Rwenzori Region, Western Uganda

# 82

Michael Robert Nkuba, Raban Chanda, Gagoitseope Mmopelwa, Akintayo Adedoyin, Margaret Najjingo Mangheni, David Lesolle, and Edward Kato

## Contents

Introduction .....	1686
Materials and Methods .....	1689
The Study Area .....	1689
Sample Size, Data Collection, and Analysis .....	1690
Empirical Model .....	1691
Results .....	1691
Socio-Economic Characteristics of Arable Farmers .....	1691
The Effect of Forecast Use on Climate Change Perceptions of Arable Farmers and Pastoralists .....	1694
The Effect of Other Factors on the Climate Change Perceptions of Arable Farmers .....	1694

This chapter was previously published non-open access with exclusive rights reserved by the Publisher. It has been changed retrospectively to open access under a CC BY 4.0 license and the copyright holder is “The Author(s)”. For further details, please see the license information at the end of the chapter.

M. R. Nkuba (✉) · R. Chanda · G. Mmopelwa · D. Lesolle  
Department of Environmental sciences, Faculty of Science, University of Botswana, Gaborone, Botswana  
e-mail: [mnkuba@gmail.com](mailto:mnkuba@gmail.com); [chandar@mopipi.ub.bw](mailto:chandar@mopipi.ub.bw); [gmmopelwa@mopipi.ub.bw](mailto:gmmopelwa@mopipi.ub.bw); [david.lesolle@mopipi.ub.bw](mailto:david.lesolle@mopipi.ub.bw)

A. Adedoyin  
Department of Physics, Faculty of Science, University of Botswana, Gaborone, Botswana  
e-mail: [akintayo\\_adedoyin@yahoo.com](mailto:akintayo_adedoyin@yahoo.com)

M. N. Mangheni  
Department of Extension and Innovation Studies, College of Agricultural and Environmental Sciences, Makerere University, Kampala, Kampala, Uganda  
e-mail: [mnmangheni@gmail.com](mailto:mnmangheni@gmail.com)

E. Kato  
International Food Policy and Research Institute, Washington, DC, USA  
e-mail: [E.Kato@cgiar.org](mailto:E.Kato@cgiar.org)

Discussion .....	1698
Conclusion .....	1699
References .....	1700

## Abstract

Despite the dissemination of climate information from national meteorological systems, arable farmers still have challenges of dealing with climate-related risks. This study investigated the effect of using indigenous knowledge-based forecasts (IFs) and scientific knowledge-based forecasts (SFs) on the climate change perceptions of arable farmers in the Rwenzori region, Western Uganda. Data on socio-economic characteristics, use of forecasts, and climate change perceptions was collected from 580 arable farmers and the probit model was used in the analysis. The findings indicated that use of IFs only increased the likelihood of perceiving increase in the frequency in occurrences of droughts and floods. Using both SFs and IFs had a significant positive effect on perception of unpredictable rains and the increase in drought incidence among arable farmers. Although forecasts are important drivers of perceptions, other factors, such as gender, social capital, and dissemination of climate change information by radio, enhance climate change perceptions. Active participation of arable farmers in the dissemination of forecasts by national meteorological services could improve perceptions of climate related risks.

## Keywords

Scientific forecasts · Indigenous knowledge · Indigenous forecasts · Climate change perceptions · Arable farmers · Uganda

## Introduction

Despite the dissemination of scientific knowledge-based climate forecasts (SFs) by national meteorological systems, arable farmers still face challenges of dealing with climate-related risks. The impact of 1.5 degrees centigrade of global warming will significantly decrease agricultural production and access to water, and increase drought frequency and dry spells in Africa (IPCC 2018a). SFs influence disaster risk perceptions in general and climate change perceptions in particular for arable farmers and pastoralists. The climate change perceptions of arable farmers can influence farmers' adaptation to extreme weather events. Failure to use SFs may have negative effects on the adoption of disaster risk-reduction strategies. Failure to use early-warning information has resulted in loss of property, livestock, crops, and human lives as a result of disasters such as floods and droughts. For example, the floods in Mozambique in 2000 had a huge humanitarian effect on the local communities (Moore et al. 2003). Indigenous and scientific forecasts enhance climate change adaptation strategies of pastoralists (Nkuba et al. 2019b) and arable farmers (Nkuba et al. 2020a). Climate information use can improve the climate change

perceptions of arable farmers, leading to better adaptation to extreme weather events and improved resilience to climate-related disasters. There are initiatives that are promoting a co-production of climate information which involves indigenous and scientific forecasts (IPCC 2018b). In this chapter, drought increase refers to increase in frequency and severity of droughts and flood increase refers to increase in frequency and severity of floods.

The most common climate change perceptions among farmers in Uganda include flood increase (Mubiru et al. 2015), drought increase (Cooper and Wheeler 2017; Mubiru et al. 2015; Napa 2007; Okonya et al. 2013), rainfall seasonality change (Cooper and Wheeler 2017; Napa 2007; Okonya et al. 2013; Tiyo et al. 2015), and temperature increase (Mubiru et al. 2015; Napa 2007; Okonya et al. 2013; Tiyo et al. 2015). The perceptions commonly cited in the Rwenzori region include flood increase, drought increase, and rainfall seasonality change (Oxfam 2008; RTT 2011). The use of indigenous knowledge-based climate forecasts (IFs) and SFs influences climate change perceptions in Uganda (Napa 2007; Waisswa and Otim 2012). In spite of high or widespread access to SFs due to the proliferation of radio stations in Uganda's rural areas (NAPA 2007), the use of IF is still high (Napa 2007; Okonya and Kroschel 2013). The spatial location of the Rwenzori, region combined with relief features such as Mount Rwenzori, forested areas, and flood plains in lowlands, makes it vulnerable to extreme weather events (Oxfam 2008; RTT 2011). Research in Uganda has shown that agro-ecological zones have an influence on climate change perceptions (Mubiru et al. 2015; Okonya et al. 2013; Tiyo et al. 2015). Climate-related disasters that occur in Uganda include droughts, floods (Oxfam 2008), landslides, temperature increase, and rainfall seasonality change (Napa 2007). Therefore, this chapter has taken into account agro-ecological zones.

Farmers' use of IFs as a source of climate information influences their climate change perceptions. The literature shows that IFs have influenced the livelihoods of farmers globally. Such influence has, for instance, been reported in Australia (Green et al. 2010), West Africa (Nyong et al. 2007; Roncoli et al. 2002), East Africa (Speranza et al. 2010), Southern Africa (Kalanda-Joshua et al. 2011; Kolawole et al. 2014; Motsumi et al. 2012), Samoa (Lefale 2010), New Zealand (King et al. 2008), the Arctic (Pennesi et al. 2012), Mongolia (Andrei 2010), British Columbia in Canada (Gearheard et al. 2010), and Asia (Galacgac and Balisacan 2009). IFs have influenced the choice of crop enterprises among arable farmers.

Climate change perception studies using econometric models to analyze the effect of climate information have produced mixed results. A study done in Kenya revealed that climate information positively and significantly influenced farmers' climate change perceptions (Ndambiri et al. 2013). However, while several other studies (Gbetibouo 2009; Silvestri et al. 2012; Tesfahunegn et al. 2016) have reported that climate information positively influenced climate change perceptions, the influence was not statistically significant. In fact there are also studies (Bryan et al. 2013; Gbetibouo 2009) that have reported that climate information negatively influenced farmers' perceptions. Thus, there seems to be a lack of unanimity about the direction of influence that climate information has on farmers' perceptions of climate change risks. Most of the literature does not specify whether farmers used IFs or both IFs

**Table 1** Explanatory variables for climate change perceptions

Description	Expected sign	Cited literature
Age	–	Habtemariam et al. (2016), Tesfahunegn et al. (2016)
Farm experience	+	Bryan et al. (2013), Gbetibouo (2009), Silvestri et al. (2012), Thi Lan Huong et al. (2017)
Education level	+/-	Gbetibouo (2009), Habtemariam et al. (2016), Maddison (2006), Silvestri et al. (2012), Thi Lan Huong et al. (2017)
Gender: : male, female	+/-	Bryan et al. (2013), Silvestri et al. (2012), Thi Lan Huong et al. (2017)
Access to institutions: Credit access, agricultural extension access, improved crop varieties access, non-farm access, hired labor access	+/-	Bryan et al. (2013), Gbetibouo (2009), Habtemariam et al. (2016), Silvestri et al. (2012), Tesfahunegn et al. (2016), Thi Lan Huong et al. (2017)
Use of climate information: use of IF only, use of both IF and SF	+/-	Bryan et al. (2013), Gbetibouo (2009), Lybbert et al. (2007), Silvestri et al. (2012), Tesfahunegn et al. (2016), Thi Lan Huong et al. (2017)
Agro-ecological area: lowland, mountainous and forested, forested, mountainous	+/-	Chingala et al. (2017), Deressa et al. (2008)
Farm size	+/-	Gbetibouo (2009), Habtemariam et al. (2016), Tesfahunegn et al. (2016)
Sources of climate change information: radio, newspaper, fellow farmer, IK old farmer	+/-	Deressa et al. (2008), Habtemariam et al. (2016)
Access to government programs on climate change	+	Silvestri et al. (2012)

Source: Authors specification

and SFs. In fact, there is little literature on the influence of IF only or of both SF and IF on climate change perceptions of arable farmers and pastoralists.

Studies have also shown that there are a number of other factors that influence climate change perception (Table 1). These include household background factors such as farm experience, age, gender, education level, livelihood choices, farm income, and institutional factors such as agricultural extension, market access, access to credit, access to farm organizations and location-specific factors (Chingala et al. 2017; Deressa et al. 2008; Gbetibouo 2009; Habtemariam et al. 2016; Maddison 2006; Silvestri et al. 2012; Tesfahunegn et al. 2016). Climate change perception studies that included climate information in their analysis (Gbetibouo 2009; Ndambiri et al. 2013; Silvestri et al. 2012; Tesfahunegn et al. 2016) did not take into account the difference between the use of IFs and SFs, which this study has done. Studies on climate change perception have revealed that arable farmers' perceptions include drought increase, flood increase, rainfall season change, temperature increase, unpredictable rainfall increase, and rainfall decrease (Chingala

et al. 2017; Deressa et al. 2008; Gbetibouo 2009; Maddison 2006; Nhemachena and Hassan 2007; Silvestri et al. 2012).

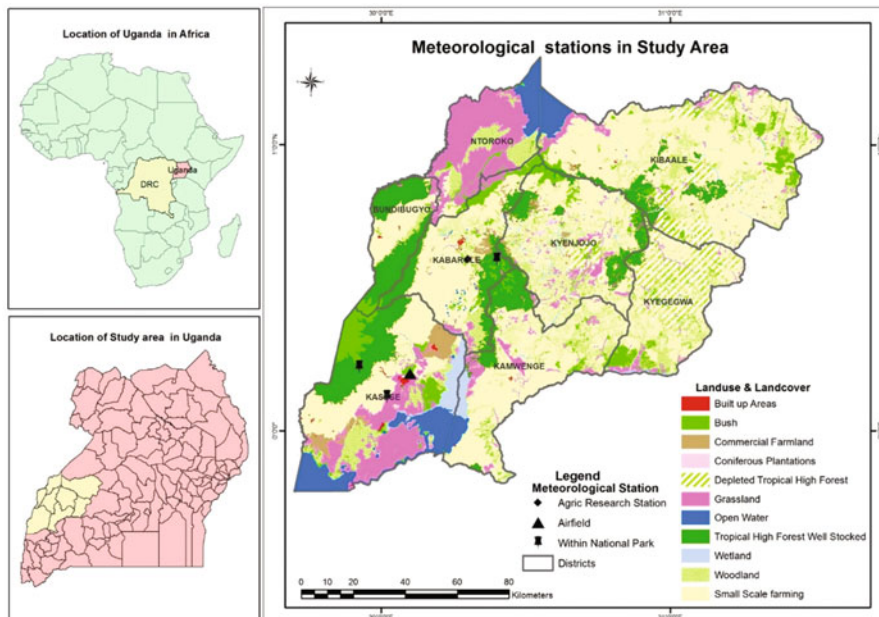
The above review of related previous studies demonstrates several realities that (a) climate information influences farmers' climate change risk perceptions but with mixed results as to the direction of influence; (b) there are other factors that may have a bearing on farmers' perceptions of climate-related risks; and (c) there is a paucity of literature on the relative influence of IFs only and/or of IFs and SFs on farmers' perceptions of climate-related risks. This study thus contributes to ongoing efforts and debate regarding the influence IFs as well as IFs and SFs on arable farmers' perceptions of climate-related risks in the Rwenzori region of Western Uganda by addressing the question "Do IFs and/or SFs influence climate change perceptions of arable farmers?" Overall, this study contributes to the climate change perception literature that relates to the influence of the use of indigenous knowledge forecasts and scientific climate forecasts on the behavior of arable farmers in Africa, in the Rwenzori region of Uganda. It also suggests what the implications are of access and use of climate information on climate change perceptions of farmers. The scope of this chapter addresses the effect of climate information on climate change perceptions of arable farmers in Western Uganda and does not cover pastoralists.

---

## Materials and Methods

### The Study Area

In the Rwenzori region of Western Uganda where the study was done (Fig. 1), farmers have reported perceiving evidence of climate change such as rains becoming more unpredictable, drought increasing in frequency and intensity and floods becoming more frequent and disastrous (Oxfam 2008). Agro-ecological zones include mountainous, lowland, mountainous and forested, wetland, and forest (Fig. 1). This agro-ecological diversity makes the Rwenzori region a good case study area for investigating how local agro-ecology influences climate change perceptions. The various agro-ecological zones are spread over the districts of Kabarole, Kyegewa, Kyenjojo, Ntoroko, Kamwenge, and Bundibugyo within the Rwenzori region and Kibale in the adjoining Bunyolo region (Fig. 1). Because this region is endowed with fauna and flora of wildlife-protected areas such as Queen Elizabeth, Kibale, Semiliki, and forested protected areas, the use of IFs is highly prevalent (Nganzi et al. 2015). Although access to SFs is high due to the proliferation of FM radio stations in Uganda (Jost et al. 2015), the use of SFs is not very high (Okonya and Kroschel 2013). Arable farming is a major source of livelihood. Rwenzori region is a multiethnic society, with many tribes whose rural livelihoods are influenced by indigenous knowledge systems. There is high variability in the onset of rains in Rwenzori region (Nkuba et al. 2019a). Indigenous forecast indicators are commonly used as sources of climate information (Nkuba et al. 2020b).



**Fig. 1** Location map of study area

## Sample Size, Data Collection, and Analysis

A two-stage stratified sampling approach (Cochran 1963) was employed to select the respondents. Farming systems and agro-ecosystems including mountainous, low-land, forested, wetland, and mountainous and forested formed the basis for the strata. The first stage units were the local agro-ecological systems, and the second-stage units were households. The statistically selected sample size of farmers was allocated to the selected districts using proportional allocation to size, where the size represents the number of households in a particular subcounty in the selected district. Based on a population of the study area of 102,496 households according to the 2014 Uganda population census report, a sample size of 778 was randomly selected with 95% confidence level and a margin of error of 3.5%. To allow for replacement in the sample of those who might back out of the study, a 19% of the statistically selected sample was included giving a total study sample of approximately 924. This was also to ensure good sized subsamples (for those who use IF and SF, and IF only). After data cleaning, 17 incomplete questionnaires were eliminated from the final analysis. The total sample size was therefore 907, and of these 580 were arable farmers, 269 were pastoralists, and 57 were agro-pastoralists. This chapter limits itself to the 580 arable farmers.

A household survey conducted from August to October 2015 was used to gather data through a face to face administered questionnaire on climate change

perceptions, household characteristics, and climate information use. Pilot testing of the questionnaire translated into the local language was done before the household survey to ensure both content and measurement validity, and the local languages were used by trained research assistants. Data was analyzed using Stata 12 statistical software. The probit model was used in the analysis.

## Empirical Model

Various econometric models have been used in climate change perception studies such as the probit model (Gbetibouo 2009; Maddison 2006), the logistic model (Silvestri et al. 2012; Tesfahunegn et al. 2016), the multinomial logit model (Bryan et al. 2013), and the Heckman probit selection model (Deressa et al. 2008; Ndambiri et al. 2013). For this study, the probit model was used in the analysis.

The empirical model is specified as follows:

$$Y_{ij} = f(H, I, A, W, S, G, U, ) + \varepsilon \dots \dots \dots (1)$$

where  $Y_{ij}$  ( $j = 1, 2, 3, 4, 5$ ) representing the climate change perceptions of farmers [ $Y_{1i} = 1$ , if drought increase (0 otherwise).  $Y_{2i} = 1$ , if floods increase (0 otherwise)  $Y_{3i} = 1$ , if unpredictable rains (0 otherwise)  $Y_{4i} = 1$ , if rainfall seasonality change (0 otherwise)  $Y_{5i} = 1$ , if temperature increase (0 otherwise)].

Household characteristics (H): the level of education, age, gender, and farming experience; use of climate information (U): use of IF only, use of both IF and SF; institutional characteristics (I): access to agricultural extension, access to improved crop, credit, and nonfarm resources; agro-ecological area (A): forested, lowland, mountainous, wetland, mountainous, and forested; wealth (W): farm size; sources of climate change information (S): radio, fellow farmer, old IK farmer, newspaper; access to government program climate change interventions (G). The expected signs for the variables are indicated in Table 1.

---

## Results

### Socio-Economic Characteristics of Arable Farmers

The descriptive characteristics show that respondents were mostly male (Table 3), of average age 46 years. The average farm size was 7.95 acres. Arable farmers mainly used the forecasts for predicting onset and cessation of rains (Tables 2). Majority of the arable farmers attained primary level of education (Table 3). The most common climate change perceptions were rainfall seasonality change and unpredictable rains (Table 4). Radio was a very important source of climate change information (Table 5).



**Table 2** Arable farmers' use of indigenous and scientific forecasts in the Rwenzori region

	Onset (%)		Cessation (%)		5-day (%)		Seasonal (%)		% of Full Sample
	Full sample	Subsample	Full sample	Subsample	Full sample	Subsample	Full sample	Subsample	
IF and SF	38	77	33	65	27	54	19	38	50
IF only	49	100	48	96	41	83	34	69	49

Source: Survey data 2015. Full sample = 580, IF and SF = 289, IF only = 287

**Table 3** Household characteristics of respondents

Variable	Variable definition	Arable farmers (N = 580)
Male	Gender of the household head (1 if female)	0.54
Female	Gender of the household head (1 if female)	0.46
No school	No formal education (1 if yes)	0.24(0.43)
Primary	Primary education (1 if yes)	0.53 (0.5)
O-level	Ordinary secondary education (1 if yes)	0.18(0.39)
Higher educ	Advanced secondary education or diploma (1 if yes)	0.04(0.18)
Secondary educ	Ordinary or advanced secondary education (1 if yes)	
Tertiary educ	Certificate, university education(1 if yes)	0.01(0.08)
Age(years)	Household head age (completed years)	45.54(14.17)
Farming exp	Farming experience (completed years)	24.11(13.72)
Farm size	Farm size owned(acres)	7.95(25.09)
Herd mobility	Herd mobility (1 if yes)	
Forest	Reside forested areas (1 if yes)	0.21(0.41)
Mountain	Reside in mountainous area (1 if yes)	0.17(0.37)
Wetlands	Reside in wetland area (1 if yes)	0.14(0.35)
Lowlands	Reside in lowland area (1 if yes)	0.34(0.47)
Mountainous and forested	Reside in mountainous and forested area (1 if yes)	0.14(0.35)

Source: Survey data 2015. Figures in parentheses are standard deviations

**Table 4** Climate variability and change perceptions and access to institutions

Variable	Variable definition	Arable farmers (N = 580)
Temp increase	Temperature increase (1 if yes)	0.22(0.42)
Rainfall seasonality change	Rainfall seasonal change (1 if yes)	0.49(0.5)
Droughts increase	Droughts increase (1 if yes)	0.21(0.41)
Floods increase	Floods increase (1 if yes)	0.11(0.31)
Unpredictable rains	Unpredictable rains (1 if yes)	0.51 (0.5)
Credit access	Credit access (1 if yes)	0.42(0.49)
Improved crop access	Improved crop access (1 if yes)	0.41(0.49)
Nonfarm access	Non-farm access (1 if yes)	0.23(0.42)
Agricultural extension access	Agricultural extension access (1 if yes)	0.11(0.32)
Access govt climate change adaptation interventions	Access to govt climate change adaptation interventions (1 if yes)	0.26(0.44)

Change in onset and cessation of rains

Source: Survey data 2015. Figures in parentheses are standard deviations. There were multiple responses for perception of climate variability and change

**Table 5** Sources of climate change information

Variable	Variable definition	Arable farmers (N = 580)
Farmer organization	Farmers organization as source of climate change information (1 if yes)	0.13(0.33)
Fellow farmer	Fellow farmers as source of climate change information (1 if yes)	0.18(0.38)
Old IK farmer	IK old farmers as source of climate change information (1 if yes)	0.22(0.42)
Radio	IK old farmers as source of climate change information (1 if yes)	0.52(0.50)
Newspapers	IK old farmers as source of climate change information (1 if yes)	0.03(0.16)

Source: Survey data 2015. Figures in parentheses are standard deviations

### The Effect of Forecast Use on Climate Change Perceptions of Arable Farmers and Pastoralists

The results show that the use of both IFs and SFs or IFs only has a positive effect on the climate change perceptions of arable farmers (Tables 6 and 7). Arable farmers using IFs only were more likely to perceive drought increase by 22% and flood increase by 8%. Arable farmers using both (IFs and SFs) were more likely to perceive unpredictable rains by 18% and drought increase by 18%. There are peculiarities in the effect of forecast use on climate change perceptions. Five-day forecasts had a negative influence on the climate change perceptions of arable farmers (Tables 6 and 7). This suggests that arable farmers do not have much confidence in short range forecasts with regard to their perceptions of risks associated with extreme weather events. The use of both IF and SF for onset of rains had a negative influence on arable farmers' perceptions of climate-related risk (Table 7). This could be due to variability in rainfall onset prediction.

### The Effect of Other Factors on the Climate Change Perceptions of Arable Farmers

Agro-ecology zones increased the likelihood of arable farmers perceiving climate change risks (Tables 6 and 7). Being resident in mountainous areas increased the likelihood of perceiving rainfall seasonality change by 22%. Rainfall seasonality change was more likely to be perceived by famers using both (SF and IF) in forested areas by 13%, wetland areas by 21%, and lowland areas by 18% (Table 7). Rainfall seasonality change was more likely to be perceived by famers using IF only in forested areas by 14%, wetland areas by 23%, and lowland areas by 19% (Table 6). Drought increase was more likely to be perceived by famers using both (SF and IF) in forested areas by 17%, mountainous areas by 15%, wetland areas by 29%, and lowland areas by 20% (Table 7). Agro-climatic risks, such as pest and disease

**Table 6** Marginal effects of climate change perceptions for arable farmers who use if only

Variable	Rfall seasonal change	Drought increase	Floods increase	Unpredictable rains
IF only for onset		0.216*** (0.068)		-0.279* (0.162)
IF only for cessation			0.078*** (0.025)	0.267(0.162)
IF only for 5 day	0.094*(0.049)	-0.259*** (0.049)		
IF only for seasonal		0.121** (0.061)		
Farm size	0.004(0.002)			
Forest	0.141*(0.077)		-0.055** (0.023)	
Mountain	0.215***(0.077)			
Wetland	0.225***(0.081)	0.087*(0.056)	-0.056* (0.024)	
Lowland	0.190***(0.074)		-0.036 (0.024)	
Agri-ext access		0.064(0.059)	-0.083** (0.020)	
Farmer org access	0.227****(0.056)	0.146*** (0.053)		0.159*** (0.057)
Credit access	0.184****(0.048)			0.077*(0.046)
Non-farm access				0.179*** (0.051)
Female	0.064(0.050)			
Male		0.079** (0.033)		
No school	-0.345** (0.143)		-0.064** (0.021)	0.272*(0.141)
Primary	-0.324** (0.151)			0.286*(0.145)
Sec educ	-0.338** (0.142)			0.353** (0.125)
Farm experience	0.002(0.002)			
Age		-0.002 (0.001)		
CC info from elderly farmer	0.277****(0.051)			0.158*** (0.051)
CC info from radio		0.133*** (0.034)		-0.132*** (0.045)
CC info from fellow farmer		-0.097** (0.040)		-0.171*** (0.062)

prevalence, land degradation due to soil erosion, water stress, climate-related extreme events such as floods and droughts, are influenced by the agro-ecosystem. The results indicate the importance of agro-ecological zones in climate change

**Table 7** Marginal effects of climate change perceptions for arable farmers who use both

Variable	Rfall seasonal change	Drought increase	Floods increase	Unpredictable rains
Both only for onset				−0.208** (0.085)
Both only for cessation	−0.093*(0.050)			0.181**(0.086)
Both only for 5 day		−0.223*** (0.031)	−0.058** (0.022)	
Both only for seasonal		0.180*** (0.065)		0.217*** (0.060)
Farm size	0.004*(0.002)			
Forest	0.130*(0.076)	0.167** (0.077)	−0.078*** (0.025)	0.055(0.054)
Mountain	0.215*** (0.076)	0.151** (0.084)	−0.040 (0.027)	0.079(0.061)
Wetland	0.205**(0.082)	0.286*** (0.096)	−0.074** (0.022)	
Lowland	0.175**(0.074)	0.191*** (0.074)	−0.067** (0.026)	
Agri-ext access		0.071(0.060)	−0.089** (0.019)	
Farmer org access	0.231*** (0.055)	0.121** (0.054)		0.168*** (0.057)
Credit access	0.182*** (0.048)			0.066(0.046)
Nonfarm access				0.189*** (0.051)
Female	0.063(0.050)			
Male		0.073** (0.033)		0.052(0.045)
No school	−0.329** (0.145)			
Primary	−0.333** (0.152)			
Sec educ	−0.340** (0.143)			0.072(0.056)
Age		−0.002 (0.001)		
CC info from elderly farmer	0.275*** (0.051)			0.176*** (0.051)
CC info from newspapers		0.177(0.135)		
CC info from radio		0.076** (0.035)		−0.133*** (0.045)
CC info from fellow farmer		−0.104** (0.037)		−0.185*** (0.061)

\*\*\*, \*\*, and \* denote that significance at the 1%, 5% and 10% levels respectively

perception studies. Failure to consider agro-ecological zones in climate change adaptation programs and policies can lead to poor adaptation. The findings also reveal that gender increased the likelihood of arable farmers perceiving climate change (Tables 6 and 7). Being male increased the likelihood of arable farmers' perceptions of drought increase by 7%. Men influence the choice of crop enterprises in farming households based on their climate change perceptions. A participant in a focus group discussion (FDG) reported that "now there is when you want to sow groundnuts but because of the early onset of the rains before you have planted then you plant maize instead." There are mixed results regarding the effect of agricultural extension on climate change risk perception. Agricultural extension access decreased the likelihood of pastoralists' perceptions of drought increase but increased the likelihood of perception of temperature increase. It is plausible that agricultural extension is the source of information on temperature increase received in the 10-day forecasts from the Uganda National Meteorological authority. Agricultural extension access decreased the likelihood of arable farmers' perceptions of flood increase by 8%. This suggests that agricultural extension is not effective in reducing risk attitudes associated with floods.

The results further indicate that access to credit and farmers' organizations increased the likelihood of arable farmers perceiving rainfall seasonality change by 18% and 23%, respectively. This suggests that access to credit contributes to rainfall seasonality change risk perception. The results further indicate that access to farmers' organizations increased the likelihood of arable farmers perceiving drought increase by over 11% and unpredictable rains by 16%. This suggests that social capital contributes to risk perception.

The study shows that access to nonfarm enterprises had a significant positive influence on climate change perception. Access to nonfarm enterprises increased the likelihood of arable farmers' perceptions of unpredictable rains by 18%. This could be attributed to arable farmers reinvesting their nonfarm incomes in agricultural technologies which are climate sensitive (Farmers tend to invest in agricultural inputs, hiring labor (Reardon et al. 1994)). The study also shows that there are mixed results regarding the effect of climate change information (depending on the source) on climate change risk perceptions. For instance, on the one hand, access to radio had positive effect on climate change risk perceptions. Climate change information from listening to radio also increased the likelihood of perceiving drought increase by arable farmers by 13% for those who use IF only and 7% for those who use both. This implies that radio is an effective dissemination mechanism for climate change information.

On the other hand, climate change information gained from fellow farmers negatively influenced climate change risk perceptions by more than 17% (Tables 6 and 7). This could be due to inadequate information about climate change. A participant in an FGD reported not having information on climate change. This calls for capacity building in farmer-to-farmer networks, with climate change messages inserted in agricultural extension interactions. Climate change information given by elderly farmers had a positive effect on perceptions of change in rainfall seasonality by more than 15%. Elderly farmers accumulate knowledge and improve

their risk attitudes towards climate-related risk over time. Estimation of temperature increase involves consideration of maximum and minimum temperatures over long periods of time, which meteorologists calculate using models created by statistical software.

This study has established that the source of climate change information matters in arable farmers' perceptions of climate-related risks. The study produced mixed results regarding the effect of education on climate change risk perceptions (Tables 6 and 7). On one hand, education was inversely related to the perception of increase in rainfall seasonality change among farmers, and on the other, education seemed to have a positive influence on arable farmers' perceptions of an increase in the unpredictability of rainfall. This suggests that irrespective of level of education, changes in the onset and cessation of rains are not easily perceived by farmers. This could be due to the effect of climate variability on onset of rains. A key informant reported that onsets of rains were highly variable.

---

## Discussion

The study findings reveal that being male, climate information, access to agricultural extension positively influenced perceptions of drought increase among arable farmers, which is consistent with study of Vietnamese farmers undertaken by (Thi Lan Huong et al. 2017). However, the study also shows that there are mixed results regarding the effect of agricultural extension on climate change risk perception, which is in agreement with earlier studies that showed a positive effect (Bryan et al. 2013; Deressa et al. 2008; Gbetibouo 2009; Opiyo et al. 2016) and others that showed negative effect (Silvestri et al. 2012). Research shows that agricultural extension is a dissemination mechanism for climate information and climate change information (Deressa et al. 2008; Gbetibouo 2009; Opiyo et al. 2016). Bryan et al. (2013) indicated that agricultural extension positively influenced perceptions of temperature increase among arable farmers in Kenya, but Nkonya et al. (2015) reported that agricultural extension in Uganda and Nigeria was weak in disseminating climate change information, making it less relevant in improving the resilience of farmers to climate-related risks. This is consistent with the study's findings that show that access to agricultural extension negatively influenced perceptions of flood increase among arable farmers.

The results show that using IF only positively influenced perceptions of flood increase among arable farmers which is consistent with Thi Lan Huong et al. (2017) who reported that climate information had a positive effect on Vietnamese farmers' perceptions of flood increase.

The results show that the use of both IF and SF has a positive effect on arable farmers who perceive unpredictable rains, which is consistent with Bryan et al. (2013), indicated that SF positively influenced farmers' perceptions of rainfall variability. The findings reveal that credit access increased the likelihood of arable farmers' perceptions of climate change, which in agreement with an earlier study by Silvestri et al. (2012). The study revealed that climate change information from radio

increased the likelihood of perceiving drought increase by arable farmers which is consistent with Deressa et al. (2008); Habtemariam et al. (2016), who indicated that climate change information had a positive effect on perception. The study shows that there are mixed results about the effect of education on climate change perceptions which is in agreement with earlier studies that showed a positive effect (Bryan et al. 2013; Deressa et al. 2008; Habtemariam et al. 2016; Ndambiri et al. 2013; Opiyo et al. 2016; Silvestri et al. 2012; Tesfahunegn et al. 2016; Thi Lan Huong et al. 2017) and others that showed negative effect (Gbetibouo 2009; Piya et al. 2012). Research has shown that education increases access to information that improves farmers' resilience to climate-related risks (Opiyo et al. 2016). The study established that irrespective of the level of education, changes in onset and cessations of rains are not easily perceived by arable farmers. Research has shown that there is high variability in onset of rains in Kenya (Recha et al. 2012), Botswana (Byakatonda et al. 2018), and South Africa (Moeletsi and Walker 2012) making an accurate prediction of start of rains a hard undertaking for national meteorological services.

The study reveals that access to farmers' organizations increased the likelihood of arable farmers perceiving climate change which is in agreement with earlier studies (Piya et al. 2012; Tesfahunegn et al. 2016). The study shows that there are mixed results regarding the effect of nonfarm access on climate change perception, which is consistent with earlier studies (Silvestri et al. 2012) that showed a positive effect and others that showed a negative effective effect (Deressa et al. 2008; Ndambiri et al. 2013; Opiyo et al. 2016; Piya et al. 2012; Tesfahunegn et al. 2016). Nonweather dependent ventures such as small and medium enterprises may have a negative effect on arable farmers' perceptions of climate-related risks, while climate sensitive ventures such as livestock and crop sales have a positive effect on perceptions (Opiyo et al. 2016). Deressa et al. (2008) have indicated that nonfarm incomes may contribute to making high-income farmers less risk averse.

The study shows that agro-ecological zones increased the likelihood of arable farmers perceiving climate change which is consistent with Deressa et al. (2008), who reported that being resident in highlands had a positive effect on farmers' perceptions of climate change. Other scholars (Fadina and Barjolle 2018; Gedefaw et al. 2018) have also reported the influence of agro-ecology on perceptions of climate-related risks.

---

## Conclusion

The study has established that the use of scientific and/or indigenous knowledge-based forecasts had varying influence on the perception of climate-related risks among arable farmers in the study area. Specifically, the study has revealed that use of IF only increased the likelihood of perceiving climate change as drought increase and flood increase. The use of both SF and IF positively influenced the perceptions of unpredictable rains and drought increase by arable farmers. The study has proven that SF complements IF in arable farmers' perceptions of climate change. The study has established that the source of climate change information matters in



farmers' perception of climate-related risks. The study highlights the importance of forecast information sourced from indigenous knowledge systems and meteorologists regarding farmers' perceptions of climate-related risks under rain-fed agriculture. This therefore underscores the need for the integration of indigenous knowledge forecasts with the national meteorological services. Although forecasts are an important aspect of equipping farmers with information that will help them perceive climate change, the results of this study show that the direct impact of forecasts in enhancing farmer perceptions is limited to specific risks. Therefore, climate information, although necessary, is not sufficient; other factors are also important. Gender, social capital, and radio dissemination of climate change information require special attention when developing and implementing strategies for improving resilience to climate-related risks in rural livelihoods. The active participation of arable farmers and pastoralists in forecast dissemination by National meteorological services would improve farmers' perceptions of climate-related risks.

### Lessons Learnt

Indigenous forecasts and scientific forecasts enhance arable farmers' perceptions of climate change. Indigenous knowledge systems play an important role in climate-related risk perception. Factors such as gender, social capital, and dissemination of climate change information by radio improve climate change perceptions.

### Future Prospects

An increase in infrastructural investment in meteorology would improve farmers' perception of climate-related risks. This would investment would increase the precision of meteorological forecasts by having a higher meteorological density at district level, consequently improving the early-warning system of climate-related disaster risks.

---

## References

- Andrei M (2010) Riders under storms: contributions of nomadic herders' observations to analysing climate change in Mongolia. *Glob Environ Chang* 20:162–176. <https://doi.org/10.1016/j.gloenvcha.2009.10.004>
- Bryan E, Ringler C, Okoba B, Roncoli C, Silvestri S, Herrero M (2013) Adapting agriculture to climate change in Kenya: household strategies and determinants. *J Environ Manag* 114:26–35. <https://doi.org/10.1016/j.jenvman.2012.10.036>
- Byakatonda J, Parida B, Kenabatho PK, Moalafhi D (2018) Analysis of rainfall and temperature time series to detect long-term climatic trends and variability over semi-arid Botswana. *J Earth Syst Sci* 127(2):25
- Chingala G, Mapiye C, Raffrenato E, Hoffman L, Dzama K (2017) Determinants of smallholder farmers' perceptions of impact of climate change on beef production in Malawi. *Clim Chang* 142(1):129–141. <https://doi.org/10.1007/s10584-017-1924-1>
- Cochran WG (1963) *Sampling Technique*, 2nd edn. Wiley, New York
- Cooper SJ, Wheeler T (2017) Rural household vulnerability to climate risk in Uganda. *Reg Environ Chang* 17(3):649–663
- Deressa T, Hassan RM, Alemu T, Yesuf M, Ringler C (2008) Analyzing the determinants of farmers' choice of adaptation methods and perceptions of climate change in the Nile Basin of

- Ethiopia (Vol. IFPRI discussion paper 798). USA International Food Policy Research Institute, Washington DC
- Fadina AMR, Barjolle D (2018) Farmers' adaptation strategies to climate change and their implications in the Zou Department of South Benin. *Environments* 5(1):15
- Galacgac ES, Balisacan CM (2009) Traditional weather forecasting for sustainable agroforestry practices in Ilocos Norte Province, Philippines. For *Ecol Manage* 257(10):2044–2053. <https://doi.org/10.1016/j.foreco.2009.01.002>
- Gbetibouo GA (2009) Understanding farmers' perceptions and adaptations to climate change and variability: the case of the Limpopo Basin, South Africa (Vol. IFPRI discussion paper 849). USA International Food Policy Research Institute, Washington DC
- Gearheard S, Pocerlich M, Stewart R, Sanguya J, Huntington HP (2010) Linking Inuit knowledge and meteorological station observations to understand changing wind patterns at Clyde River, Nunavut. *Clim Chang* 100(2):267–294. <https://doi.org/10.1007/s10584-009-9587-1>
- Gedefaw M, Girma A, Denghua Y, Hao W, Agitew G (2018) Farmer's perceptions and adaptation strategies to climate change, its determinants and impacts in Ethiopia: evidence from Qwara District. *J Earth Sci Clim Chang* 9(481):2
- Green D, Jack B, Alo T (2010) Indigenous Australians' knowledge of weather and climate. *Clim Change* 100:337–354. <https://doi.org/10.1007/s10584-010-9803-z>
- Habtemiah LT, Gandorfer M, Kassa GA, Heissenhuber A (2016) Factors influencing smallholder farmers' climate change perceptions: a study from farmers in Ethiopia. *Environ Manag* 58(2):343–358
- IPCC (2018a) Impacts of 1.5°C of global warming on natural and human systems. Retrieved from Cambridge University Press, Cambridge, UK/New York
- IPCC (2018b) Strengthening and implementing the global response. Retrieved from Cambridge University Press, Cambridge, UK/New York
- Just C, Kyazze F, Naab J, Neelormi S, Kinyangi J, Zougmore R et al (2015) Understanding gender dimensions of agriculture and climate change in smallholder farming communities. *Clim Dev* 8(2):1–12. <https://doi.org/10.1080/17565529.2015.1050978>
- Kalanda-Joshua M, Ngongondo C, Chipeta L, Mpembeka F (2011) Integrating indigenous knowledge with conventional science: enhancing localised climate and weather forecasts in Nessa, Mulanje, Malawi. *Phys Chem Earth Parts A/B/C* 36(14–15):996–1003. <https://doi.org/10.1016/j.pce.2011.08.001>
- King DNT, Skipper A, Tawhai WB (2008) Māori environmental knowledge of local weather and climate change in Aotearoa – New Zealand. *Climatic Change* 90:385–409. <https://doi.org/10.1007/s10584-007-9372-y>
- Kolawole OD, Wolski P, Ngwenya B, Mmopelwa G (2014) Ethno-meteorology and scientific weather forecasting: small farmers and scientists' perspectives on climate variability in the Okavango Delta, Botswana. *Clim Risk Manag* 4:43–58
- Lefale PF (2010) Ua 'afa le Aso stormy weather today: traditional ecological knowledge of weather and climate. The Samoa experience. *Clim Change* 100:317–335. <https://doi.org/10.1007/s10584-009-9722-z>
- Lybbert TJ, Barrett CB, Mpeak JG, Luseno WK (2007) Bayesian herders: updating of rainfall beliefs in response to external forecasts. *World Dev* 35(3):480–497. <https://doi.org/10.1016/j.worlddev.2006.04.004>
- Maddison D (2006) The perception of and adaptation to climate change in Africa (Vol. CEEPA discussion paper no. 10). Centre for environmental economics and policy in Africa, University of Pretoria, South Africa
- Moeletsi M, Walker S (2012) Rainy season characteristics of the free state province of South Africa with reference to rain-fed maize production. *Water SA* 38(5):775–782
- Moore S, Eng E, Daniel M (2003) International NGOs and the role of network centrality in humanitarian aid operations: a case study of coordination during the 2000 Mozambique floods. *Disasters* 27(4):305–318
- Motsumi S, Magole L, Kgathi D (2012) Indigenous knowledge and land use policy: implications for livelihoods of flood recession farming communities in the Okavango Delta, Botswana. *Phys Chem Earth Parts A/B/C* 50–52:185–195. <https://doi.org/10.1016/j.pce.2012.09.013>

- Mubiru DN, Kyazze FB, Radeny, M, Zziwa A, Lwasa J, Kinyangi J (2015) Climatic trends, risk perceptions and coping strategies of smallholder farmers in rural Uganda. Retrieved from CCFAS Working paper No 121. CGIAR Research Program on Climate Change, Agriculture and Food Security. Copenhagen, Denmark. <http://hdl.handle.net/10568/67139>
- Napa (2007) Uganda national adaptation plans of action. Ministry of Environment, Government of Uganda, Kampala, Uganda
- Ndambiri HK, Ritho CN, Mbogoh SG (2013) An evaluation of farmers' perceptions of and adaptation to the effects of climate change in Kenya. *Int J Food Agric Econ* 1(1):75–96
- Nganzi P, Kajumba TC, Barihaihi M, Bataze J, Mujuni G (2015) Use of indigenous knowledge in weather forecasting in Uganda. National survey. Retrieved from Uganda National Meteorology Authority, Kampala
- Nhemachena C, Hassan R (2007) Micro-level analysis of farmers adaption to climate change in Southern Africa: Intl Food Policy Res Inst. Retrieved from Washington DC
- Nkonya E, Place F, Kato E, Mwanjololo M (2015) Climate risk management through sustainable land management in sub-Saharan Africa. In: Sustainable intensification to advance food security and enhance climate resilience in Africa. Springer, Switserland, pp 75–111
- Nkuba M, Chanda R, Mmopelwa G, Adedoyin A, Mangheni MN, Lesolle D, Kato E (2019a) Do indigenous forecasts and scientific forecasts influence arable farmers' and agro-pastoralists' estimation of onset and cessation of rains? Empirical evidence from Rwenzori region, Western Uganda. *Agric For Meteorol* 278:107667. <https://doi.org/10.1016/j.agrformet.2019.107667>
- Nkuba M, Chanda R, Mmopelwa G, Kato E, Mangheni MN, Lesolle D (2019b) The effect of climate information in pastoralists' adaptation to climate change: a case study of Rwenzori region, Western Uganda. *Int J Climate Change Strategies Manage* 11(4):442–464. <https://doi.org/10.1108/IJCCSM-10-2018-0073>
- Nkuba M, Chanda R, Mmopelwa G, Kato E, Mangheni MN, Lesolle D (2020a) Influence of indigenous knowledge and scientific climate forecasts on arable farmers' climate adaptation methods in the Rwenzori region, Western Uganda. *Environ Manag.* <https://doi.org/10.1007/s00267-020-01264-x>
- Nkuba M, Chanda R, Mmopelwa G, Mangheni MN, Lesolle D, Kato E (2020b) Indigenous knowledge systems and indicators of rain: evidence from Rwenzori region, Western Uganda. *Weather Climate Soc* 12(2):213–234. <https://doi.org/10.1175/wcas-d-19-0027.1>
- Nyong A, Adesina F, Osman EB (2007) The value of indigenous knowledge in climate change mitigation and adaptation strategies in the African Sahel. *Mitig Adapt Strat Glob Change* 12:787–797. <https://doi.org/10.1007/s11027-007-9099-0>
- Okonya JS, Kroschel J (2013) Indigenous knowledge of seasonal weather forecasting: a case study in six regions of Uganda. *Agric Sci* 04(12):641–648. <https://doi.org/10.4236/as.2013.412086>
- Okonya JS, Syndikus K, Kroschel J (2013) Farmers' perception of and coping strategies to climate change: evidence from six agro-ecological zones of Uganda. *J Agric Sci* 5(8):252
- Opiyo F, Wasonga OV, Nyangito MM, Mureithi SM, Obando J, Munang R (2016) Determinants of perceptions of climate change and adaptation among Turkana pastoralists in northwestern Kenya. *Clim Dev* 8(2):179–189. <https://doi.org/10.1080/17565529.2015.1034231>
- Oxfam (2008) Turning up the heat. Climate change and Poverty in Uganda. Retrieved from Kampala, Uganda. <https://core.ac.uk/download/pdf/48023233.pdf>
- Pennesi K, Arokium J, McBean G (2012) Integrating local and scientific weather knowledge as a strategy for adaptation to climate change in the Arctic. *Mitig Adapt Strateg Glob Chang* 17(8):897–922. <https://doi.org/10.1007/s11027-011-9351-5>
- Piya L, Maharjan KL, Joshi NP (2012) Perceptions and realities of climate change among the Chepang communities in rural mid-hills of Nepal. *J Contemp India Stud* 2:35–50
- Reardon T, Crawford E, Kelly V (1994) Links between nonfarm income and farm investment in African households: adding the capital market perspective. *Am J Agric Econ* 76(5):1172–1176
- Recha C, Makokha G, Traore P, Shisanya C, Lodoun T, Sako A (2012) Determination of seasonal rainfall variability, onset and cessation in semi-arid Tharaka district, Kenya. *Theor Appl Climatol* 108(3–4):479–494

- Roncoli C, Ingram K, Kirshen P (2002) Reading the rains: local knowledge and rainfall forecasting in Burkina Faso. *Soc Nat Resour* 15(5):409–427. <https://doi.org/10.1080/08941920252866774>
- RTT (2011) Small holder farmers' knowledge and adaptation to climate change in Rwenzori region. Retrieved from Fort Portal, Uganda. Rwenzori ThinkTank
- Silvestri S, Bryan E, Ringler C, Herrero M, Okoba B (2012) Climate change perception and adaptation of agro-pastoral communities in Kenya. *Reg Environ Chang* 12(4):791–802. <https://doi.org/10.1007/s10113-012-0293-6>
- Speranza CI, Kiteme B, Ambenje P, Wiesmann U, Makali S (2010) Indigenous knowledge related to climate variability and change: insights from droughts in semi-arid areas of former Makueni District. *Kenya Climatic Change* 100:295–315. <https://doi.org/10.1007/s10584-009-9713-0>
- Tesfahunegn GB, Mekonen K, Tekle A (2016) Farmers' perception on causes, indicators and determinants of climate change in northern Ethiopia: implication for developing adaptation strategies. *Appl Geogr* 73:1–12
- Thi Lan Huong N, Shun Bo Y, Fahad S (2017) Farmers' perception, awareness and adaptation to climate change: evidence from Northwest Vietnam. *Int J Clim Change Strategies Manage* 9(4):555–576
- Tiyo CE, Orach-Meza F, Edroma EL (2015) Understanding small-scale farmers' perception and adaptation strategies to climate change impacts: evidence from two agro-ecological zones bordering national parks of Uganda. *J Agric Sci* 7(10):253
- Waisswa M, Otim JS (2012) On improvement of the weather information Management in Uganda. Paper presented at the proceedings and report of the 5th UbuntuNet Alliance annual conference. Promoting regional Research and Education Collaboration. Lilongwe, Malawi

**Open Access** This chapter is licensed under the terms of the Creative Commons Attribution 4.0 International License (<http://creativecommons.org/licenses/by/4.0/>), which permits use, sharing, adaptation, distribution and reproduction in any medium or format, as long as you give appropriate credit to the original author(s) and the source, provide a link to the Creative Commons license and indicate if changes were made.

The images or other third party material in this chapter are included in the chapter's Creative Commons license, unless indicated otherwise in a credit line to the material. If material is not included in the chapter's Creative Commons license and your intended use is not permitted by statutory regulation or exceeds the permitted use, you will need to obtain permission directly from the copyright holder.





# Thermodynamic Environment During the 2009 Burkina Faso and 2012 Nigeria Flood Disasters: Case Study

# 83

R. Ayodeji Balogun, E. Adesanya Adefisan, Z. Debo Adeyewa, and E. Chilekwu Okogbue

## Contents

Introduction .....	1706
The TRMM and ERA: Interim Data Description .....	1707
The 2009 Flood in Burkina Faso .....	1708
The 2012 Flood in Nigeria .....	1712
Conclusions .....	1717
References .....	1718

## Abstract

Critical or extreme atmospheric conditions which could result in flood disasters are important output for numerical weather forecast. This research applied thermodynamic variables to investigate the environment of two flood scenarios in West Africa as captured by the Tropical Rainfall Measurement Mission (TRMM) satellite. Results from the two case studies of flood events, in (i) Burkina Faso and (ii) Nigeria savannah, investigated in this research work, indicated that the September 1st 2009 flood, which was as a result of a single volumetric rainfall event of 408,070.60 ((mm/h)\*km<sup>2</sup>) with 65% convective region in Burkina Faso, was initiated by interactions between extremely large lower tropospheric wind shear and cold pool dynamics. The case of the Nigeria savannah floods between July and September, 2012, was triggered by both continuous rainfall and release

This chapter was previously published non-open access with exclusive rights reserved by the Publisher. It has been changed retrospectively to open access under a CC BY 4.0 license and the copyright holder is "The Author(s)". For further details, please see the license information at the end of the chapter.

R. A. Balogun (✉) · E. A. Adefisan · Z. D. Adeyewa · E. C. Okogbue  
Department of Meteorology and Climate Science, Federal University of Technology, Akure,  
Nigeria  
e-mail: [rabalogun@futa.edu.ng](mailto:rabalogun@futa.edu.ng); [eaadefisan@futa.edu.ng](mailto:eaadefisan@futa.edu.ng); [adeyewa@run.edu.ng](mailto:adeyewa@run.edu.ng);  
[emokogbue@gmail.com](mailto:emokogbue@gmail.com)

of water from the lagdo dam in Cameroon, which affected most of the communities in the river Benue axis. The continuous rainfalls were found to be as a result of extremely high convergence of moisture in the river Benue axis at different locations and periods. One of such rainfall events, as captured by TRMM satellite during September 29, 2012 in the Nigeria rainforest zone, indicated that the volumetric rainfall is 351,310.9 ((mm/h)\*km<sup>2</sup>) with only 34% convective portion. From these results, it can be deduced that a combination of thermodynamic environmental variables, volume rainfall, and other satellite-derived convective parameters could provide important information for flood forecasting.

---

### Keywords

Flood disaster · Thermodynamic · Environment · Volumetric rainfall · Moisture convergence

---

## Introduction

Annually, between March and early October, severe precipitation event which are often associated with flash floods events frequently cause severe damage and loss of property and lives in most countries of West Africa (Balogun et al. 2018). This climate change hazard has been linked to pressures from socioeconomic and physical factors (Merem et al. 2019). The magnitude and frequency of climate hazards have generated serious concerns in recent years in Nigeria, since the 2012 flood disaster in the country and most other West African countries in particular. Flood disasters have been a major occurrence that keeps recurring annually, in some parts of Nigeria (Magami et al. 2014). A Post-Disaster Needs Assessment (PDNA), of the 2012 Nigeria flood, was conducted by the Federal Republic of Nigeria (FRN) with technical support from United Nations, European Union, and World Bank. The major aim of the assessment was to reduce the impact of future disasters, since the floods are due to climate change (Nigeria-PDNA 2013).

Burkina Faso, which is surrounded by other West African countries particularly in the south, shared both Savannah and Sahel climates of West Africa. The economy is specifically based on cotton production and gold mining (WB 2017). Most parts of the country, and Ouagadougou which is the capital in particular, were ravaged by a devastating flood event on the 1st of September 2009 (GBF et al. 2010). This was a result of an extreme single-day rainfall amount of 261.3 mm (Karambiri 2009; GBF et al. 2010; Galvin 2010). GBF et al. 2010 stated that the September 1st 2009 flood event affected 11 out of the 13 regions in Burkina Faso with the majority of the impacts observed to be concentrated in Ouagadougou. According to GBF et al. (2010), the flood event caused at least 46 deaths and about 120,000 victims were affected. The economic impact was estimated at \$201 Million USD in damages, \$33 Million USD in losses, and \$266 Million USD in reconstruction needs (GBF et al. 2010). (Galvin 2010) concluded that the flood event was “heavy,” “extreme,” “enormous,” and “exceptional”; while GBF et al. (2010) concluded that the single-

day rainfall represented almost one-third of the total rainfall received annually during the monsoon season. The flood event has a return period of more than 10,000 years according to a preliminary statistical analysis by Karambiri (2009).

The 2012 flood disaster in Nigeria was caused by continuous heavy rainfall and the release of water from Lagdo Dam and Lake Nyos in the Cameroon. The water released affected border towns in Nigeria (Ojobor 2014). NIMET (2012) had earlier predicted, in early March during the 2012 rainfall prediction, and cautioned the Nigerian government about the possibility of continuous rainfall, which could result in destructive flooding in most states in Nigeria, with emphasis on the river basin or catchment and coastal communities of Nigeria. NIMET (2012) advised the government of Nigeria to organize public enlightenment programs so as to minimize the damages, devastation, and casualties, in terms of lives and properties, most importantly in locations and communities close to rivers, dams, among others. According to Ojobor (2014) and Agada (2015), a huge number of the populations were largely displaced in these communities, due to the 2012 flood event, as predicted by NIMET (2012). The intention was to help Government agencies and the populace to put necessary measures in place to mitigate the effects of flood waters (Ojobor 2014). The second warning came in August 2012 from Cameroun. Akaeze (2012) stated that the Nigerian Government was officially written by the Cameroon government that the Lagdo Dam located in Cameroun has already filled to capacity as a result of continuous rainfall in the location of the dam and if such rainfall amount should continue in the following week, the dam will overflow and will result in recurrent overflow of water (Akaeze 2012). According to Njoku (2013), the Cameroon authority referenced paragraph 3 of article 111, in the 2010 Nigeria–Cameroon Joint Commission regarding the interchange of relevant information as regard the situations around the Lake Nyos and Lagdo Dam, so that the Nigerian Government will take precautionary measures around the flood areas so as to avoid severe loss.

This chapter was contributed in 2019 to investigate the atmospheric environment of the two case studies discussed above. The major limitation was lack of ground observations to validate the satellite data used for this chapter.

---

## The TRMM and ERA: Interim Data Description

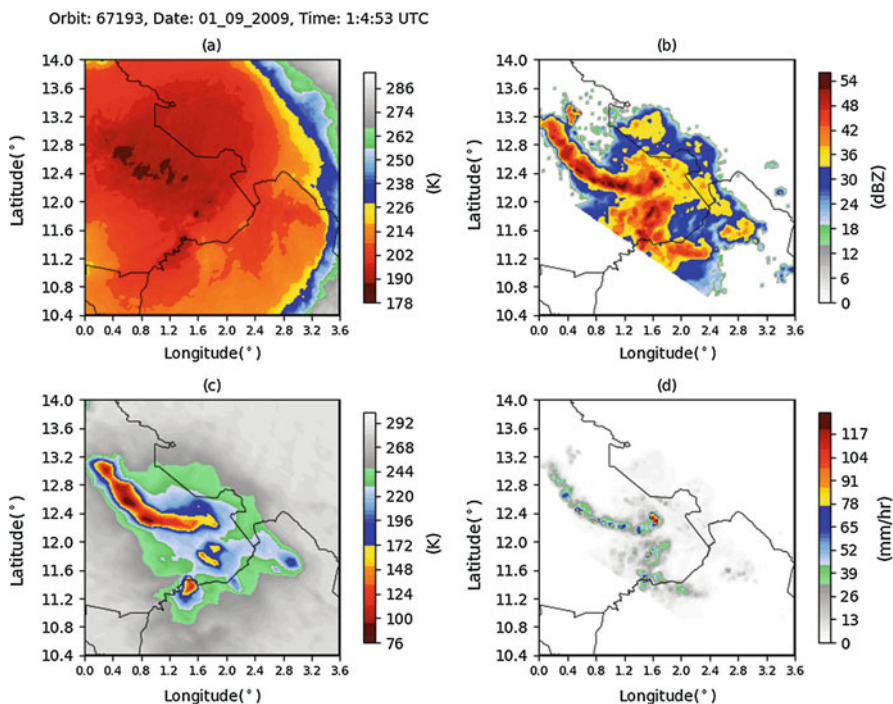
This chapter investigates high resolution ( $0.1 \times 0.1$ ) TRMM 2A25 radar-derived rainfall product, alongside derived products of the European Centre for Medium-range Weather Forecasts (ECMWF) interim reanalysis (ERA-Interim: Simmons et al. 2007; Dee et al. 2011) dataset to investigate the two (2) case studies.

The TRMM orbital data provided date, time, location, and orbit number analyzed in the case studies. The parameters analyzed from the TRMM orbital data are: Infrared (10.8 micron) brightness temperature, near-surface reflectivity, 85 GHz PCT (Polarization Corrected Temperature), and near-surface rain rate. The parameters analyzed from the environment, of ERA-Interim reanalysis dataset are Sounding (skew – T) to further provide information on convective development, convective available potential energy (CAPE), moisture fluxes, lifted index, and vertical wind

shear. The environmental parameters were analyzed at 6-hour intervals a day before, during, and a day after the case study event(s).

### The 2009 Flood in Burkina Faso

The severity of the September 1st 2009 flood made it a focal point of this chapter. The TRMM snapshot of a Mesoscale Convective System (MCS) on September 1, 2009, covering southern and western Burkina Faso, is shown in Fig. 1a-d. The Visible Infrared Scanner (VIRS), in the TRMM satellite, estimated the brightness temperature as low as 178 K in Fig. 1a. The pattern of the MCS, as shown by the near surface reflectivity (Fig. 1b), 85 GHz Polarization Corrected Temperature (PCT, Fig. 1c), and the near surface rainfall (Fig. 1d), clearly indicated that the system is a line squall which spans several kilometers. The rain rate from the single system is over 130 mm/h and the MCS is only 65% convective (Table 1), meaning that the trailing stratiform portion (region) within the system is 35%. The volume of rainfall (volumetric rainfall) from the single system is 408,070.60 ((mm/h)\*km<sup>2</sup>) (Table 1). The total number of flashcount from the single system is 191 as estimated by the Lightning

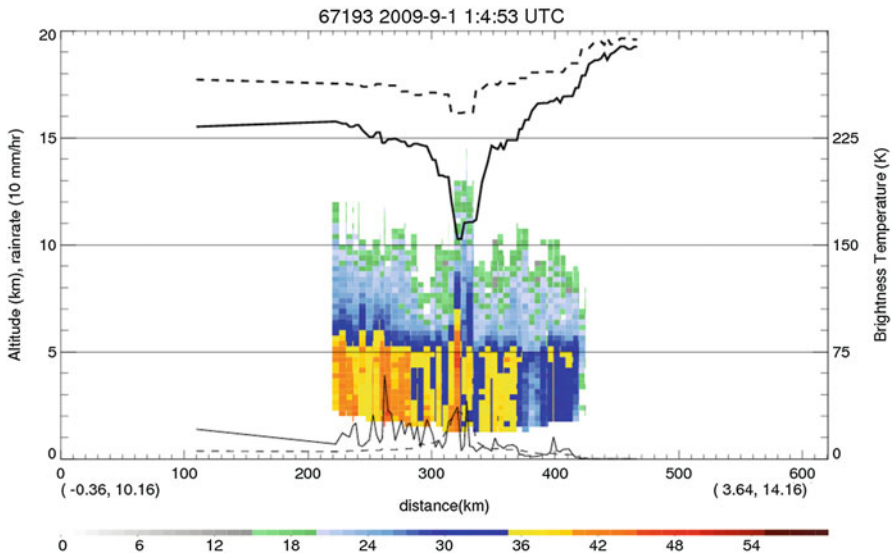


**Fig. 1** Case study of TRMM-observed MCS which occurred on 1st September 2009 in Burkina Faso noted (a) Infrared (10.8 micron) brightness temperature (T<sub>b</sub>), (b) PR near surface reflectivity, (c) 85GHz PCT of MCS, and (d) 2A25 near surface rain rate



**Table 1** Summary of some parameters from the observed system during September 1, 2009

Latitude	Longitude	% Convective	Size (Km <sup>2</sup> )	Volrain ((mm/h)*km <sup>2</sup> )	Flashcount (#)
12.16	1.64	65	52116.35	408070.6	191



**Fig. 2** Vertical cross section of the MCS which occurred on September 1, 2009

Imaging Sensor (LIS) of the TRMM satellite. The system was captured at exactly 1:04:53 am on the 1st of September 2009 by the TRMM satellite. The vertical cross section, in Fig. 2, shows that the system is about 200 km horizontally and reaches about 13–14 km altitude, which is close to the tropopause.

The thermodynamic parameters considered in this chapter to discuss the environment of this system are moisture flux convergence at the 1000 mb (hpa) level, lifted index, wind shear between 1 and 3 km, and the skewt diagram (which will provide information on the Lifting Condensation Level (LCL), Level of Free Convection (LFC), Cloud Base (CB), Cloud Top (CT), among others). The environment of the system was investigated a day before the system was captured, the day the system was captured, and the day after the system was captured.

On the August 31, 2009, a day before the flood, the location where this system occurred clearly indicated weak moisture divergence (tendency of a clear sky), in the range of 0–10 kg m<sup>-2</sup> s<sup>-1</sup> occurring in the zone, but south of this zone is the presence of strong moisture convergence (mechanism by which air is lifted for cloud formation) in the range of 55–80 kg m<sup>-2</sup> s<sup>-1</sup>. A close observation of the time periods indicates that the moisture convergence seem to be migrating northward toward the location of the system. At 18Z, part of the location of the system is already experiencing weak moisture convergence. During the night time of September 1,

2009, there was a stronger moisture convergence south of the flood event zone, but the moisture convergence was still weak in the flood event zone. Other periods (6Z, 12Z, and 18Z) did not show strong moisture convergence on the 1st of September 2009, which was the day of the flood. On 2nd of September 2009, the entire environment in which the flood occurred encountered moisture divergence, which indicated that the environment is already dry or in clear sky condition. From the analysis of the moisture flux convergence in the location of the flood, there is tendency that the system developed south of the location, and migrated northward into the zone.

The lifted index (LI), similar to the Convective Available Potential Energy (CAPE), is used to assess low level parcel (in)stability of the troposphere. A negative lifted index (LI) indicates that the boundary layer is unstable with respect to the middle troposphere. Such is an environment in which convection can occur. The more negative the LI, the more unstable the troposphere and the more buoyant the acceleration will be for rising parcels of air from the Planetary Boundary Layer (PBL). On the 31st of August 2009, the environment experienced weak instability during the night, morning, and day time, whereas during the evening time, the environment became more unstable. On the 1st of September 2009, the night time, which was preceded by the evening period of 31st August 2009, showed that the environment of the flood event location was more stable (lesser instability) than the preceding evening. A day after the flood scenario, the stability of the environment was similar to the previous day. From these discussions so far on (in)stability in the environment of the flood scenario using lifted index, it was obvious that the environment was not strongly unstable during the flood scenario event of 1st September 2009. The only case where large instability was observed, in the range of  $-4$  to  $-5$  K, was during the evening period which preceded the night time when the flood scenario occurred. In all the other periods, only marginal instabilities were observed, which may not be strong enough for buoyant acceleration of air parcels in the Planetary Boundary Layer (PBL).

The question from the foregoing is can deep convective clouds develop under this kind of environment in which the moisture convergence and instabilities were relatively weak? The zone where the flood event occurred was in the Sudano and it occurred during the JJAS season, which is the season for strong convective storms in the zone.

Vertical wind shear is an important factor for determining the development of Mesoscale Convective Systems (MCSs, Chen et al. 2015). Many studies have examined the effects of vertical wind shear on intensity and organization of convective systems, especially for squall lines (Rotunno et al. 1988; Weisman and Rotunno 2004; Coniglio et al. 2006; Takemi 2006), similar to the event being examined in this section. The effects of strong wind shear on cloud system organization depend on the altitudes where the strong wind shear occurs. Lower level shear is also favorable for organizing systems into lines or quasi-lines (Wu and Yanai 1994; Robe and Emanuel 2001; Richardson et al. 2007; DeLonge et al. 2010), as a reminder that the TRMM snapshot earlier presented showed this particular system to be an organized MCS (squall line). The vertical low level (1–3 km) wind shear seemed to gradually

developed into a severe ( $>8 \text{ s}^{-1}$ ) scale wind shear, from the night (0Z) of August 31, 2009 through to the evening period (18Z) of 31st August 2009, in the location of the flood event. This strong (severe) low level vertical wind shear, which is most severe in the eastern axis of the flood location, extends into the flood location during the evening period of 31st August 2009 and night time (0Z) of 1st September 2009 (which was the exact time the MCS was captured). This severe low level vertical wind shear could have initiated the development and evolution of convective cloud, and hence MCS similar to the finding that lower level shear directly influences the initiation and evolution of convective clouds due to interactions between lower tropospheric shear and cold pool dynamics (Rotunno et al. 1988; Moncrieff 1992; Xu et al. 1992), which could have originated from the 1000 mb moisture convergence located southward and migrated northward into the location of the flood event. Historical studies (Simpson 1969; Charba 1974) have shown that a region/zone dominated by evaporatively cooled air which was transported to lower levels via convective downdrafts and thereafter, upon reaching the surface, spread out in the form of a density current is referred to as a convective cold pool region. Goff (1976) stated that cold pools often displaced warmer environmental air as they spread out to adjacent zones. This displaced ambient air is often buoyant and are then uplifted, and thus results in the development or initiation of new convective clouds (Goff 1976; Warner et al. 1980). Droegemeier and Wilhelmson (1985) had noted that two or more collisions of cold pools are effective trigger mechanism for initiation of convection. In addition, Tompkins (2001) and Langhans and Romps (2015) stated in their works that cold pools often bring surface gusty winds that intensify sensible and latent heat fluxes, and thus modifying the thermodynamic characteristics and moisture structure of the boundary layer. The vertical wind shear subsides slightly, although still in the severe category, but maintained the severe category up till the night time (0Z) of the next day (September 2, 2009). Thereafter, the low level wind shear dropped to moderate category on the morning (6Z) of September 2, 2009 and other periods (12Z and 18Z) of the same day.

By the interaction between low level wind shear and cool pools in convective cloud initiation and development (or evolution), especially in the roles these parameters play in the Burkina Faso flood event of 1st September 2009, the next assessment of the case study is to investigate the cloud structure through the use of skew-t diagram.

Results showed that the Convective Available Potential Energy (CAPE) environment was positive (+) for all the periods (0Z, 6Z, 12Z, and 18Z) on the 31st August 2009, with the peak mean CAPE value (1392.42 J/kg) indicated by the evening period (18Z), which was the period that preceded the night time (0Z) of 1st September 2009 when the MCS system was captured. During the night time (0Z) when the MCS system was captured, the top of the cloud is around 13–14 km similar to the height estimated by the TRMM satellite in the cross section plot discussed earlier. The mean CAPE value dropped significantly during the morning (6Z), day (12Z), and evening (18Z) periods of the same day and through all the periods (0Z, 6Z, 12Z, and 18Z) of the second day, which was September 2, 2009.

Records from the flood, which lasted in the memory of the inhabitant, has it that 180, 386 victims were affected, 62 victims were wound, 41 died, and 33,172 homes were destroyed (Schlef 2018).

The 2009 flood created a lasting and strongly negative impression on the victims; they described the flood as “catastrophic” and “big” and one public official called floods “bitter experiences” while a flood victim said “*what we lived through, we have no desire to experience again*” (Schlef 2018). The flood victims and some public officials also shared their personal stories, revealing the unquantifiable and sometimes long-lasting effects of experiencing a devastating flood: “*We left the house . . . it overflowed . . . I didn’t know how to swim, so they dragged me along . . . even now when it rains at night I can’t sleep – I’m afraid! And I’m not the only one*” (Schlef 2018).

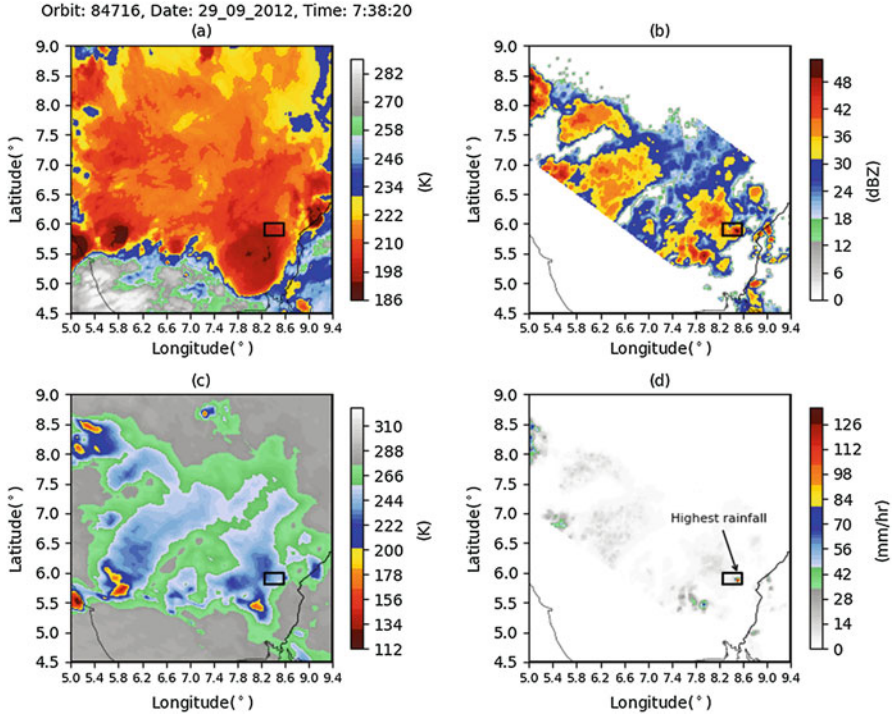
## The 2012 Flood in Nigeria

Between July and October 2012, floods which resulted from the predicted heavy rains and the released water from Lagdo dam in Cameroon pushed rivers over their banks and submerged hundreds of thousands of acres of farmland. By mid-October, these floods had forced 1.3 million people from their homes and claimed 431 lives (Agada 2015). The severity of the 2012 Nigeria flood made it a focal point of this chapter. The TRMM snapshot of a Mesoscale Convective System (MCS), with an extreme volume rainfall (Table 2) of 351,310.9 ((mm/h)\*km<sup>2</sup>) on 29th September 2012 (one of the days of the flood), in Ofutop II (a community close to Ikom Cross River state) is shown in Fig. 3. The Visible Infrared Scanner (VIRS), in the TRMM satellite, estimated the brightness temperature as low as 186 K in Fig. 3a. The rain rate from the single system is over 140 mm/h and the MCS is only 34.1% convective (Table 2), meaning that the trailing stratiform portion (region) within the system is 65.9%. The total number of flash count from the single system is 5 (Table 2) as estimated by the Lightning Imaging Sensor (LIS) of the TRMM satellite. The system was captured at exactly 7:38:20 am on the 29th of September 2012 by the TRMM satellite. By the last three (3) sentences (stratiform region was 65.9%, only 5 flashcount was estimated, and the system occurred in the morning diurnal), clearly this system is more of stratiform than convective, which would have lasted for a long time before it completely decayed. The vertical cross section in Fig. 4 shows that the system extends over 200 km horizontally and reached only about 8 km altitude in the atmosphere, and no depressed brightness temperature was observed in the cross section of the system.

As was analyzed for the Burkina Faso flood scenario, the thermodynamic parameters to investigate the environment of this system are: moisture flux convergence at the 1000 mb (hpa) level, lifted index, wind shear between 1 and 3 km, and the skewt diagram (which will provide information on the Lifting Condensation Level (LCL),

**Table 2** Summary of some parameters from the observed system during 29th September 2012

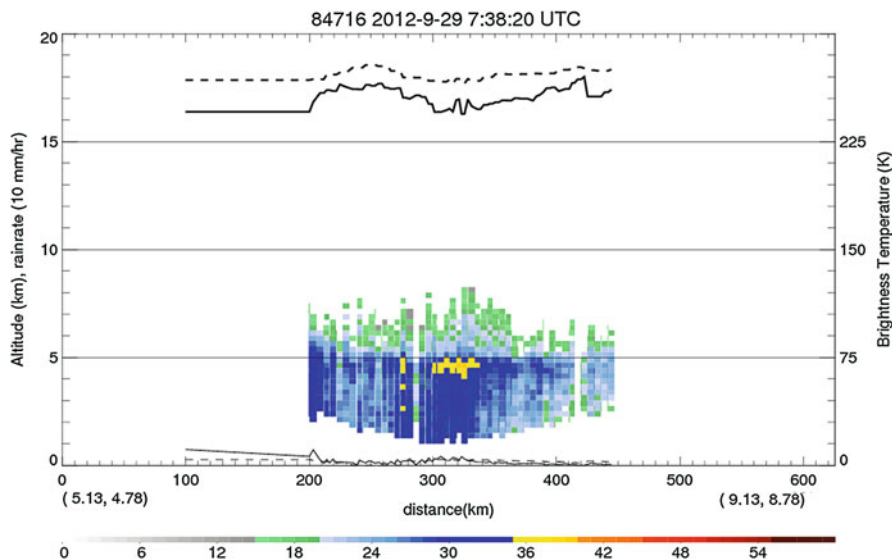
Latitude	Longitude	% convective	Size (km <sup>2</sup> )	Volrain ((mm/h)*km <sup>2</sup> )	Flashcount (#)
6.78	7.13	34.1	83190.8	351310.9	5



**Fig. 3** Case study of TRMM-observed MCS which occurred on September 29, 2012 in Nigeria, where (a) Infrared (10.8 micron) brightness temperature ( $T_b$ ), (b) PR near surface reflectivity, (c) 85GHz PCT of MCS, and (d) 2A25 near surface rain rate

Level of Free Convection (LFC), Cloud Base (CB), Cloud Top (CT), among others). For this case study, the environment of the system was investigated a day before the system was captured, the day the system was captured, and five (5) additional days after the system was captured because the flood affected many parts of Nigeria, and was reported to last many days beginning from around July to around mid-October.

On 28th of September 2012, a day before the system was captured by the TRMM satellite, extreme low level moisture flux convergence was observed during all the periods (0Z, 6Z, 12Z and 18Z), especially along the axis of the river Benue bank, which were the most affected areas (the Nigeria savannah zone). The communities in Nigeria affected by this extreme low level moisture flux convergence are Aguleri in Anambra state, Katsina Ala in Benue state, Makurdi in Benue state, Ikom in Cross River state, Lokoja in Kogi state, among others. It has been noted by Ismail and Siadari (2017) that if the atmosphere is unstable with abundant low-level moisture and a mechanism exists to lift the air (thereby releasing the potential instability), convective weather and rainfall (showers) can develop. On September 29, 2012, the affected areas were still under the influenced of extreme low-level moisture flux convergence, including Ofutop II in Cross River state where the peak rainfall rate was observed. On September 30, 2012, Aguleri community in Anambra state was



**Fig. 4** Vertical cross section of the MCS which occurred on September 29, 2012

under the influence of extreme low level moisture flux convergence during the night time. According to Vanguard newspaper of 7th October 2012, the then governor of Anambra state, Governor Peter Obi, had to suspend the Independence Day celebration of Nigeria, slated for 1st of October 2012, so as to pass through the flooded Onitsha-Osomala road in Nmiata and Ogbaru road in Anambra West in order to supervise the removal of victims trapped in their communities by the devastating flood event. Vanguard newspaper of 7th October 2012 further stated that the entire Nzam, Aguleri Otu (a community where the then President of Nigeria, Goodluck Jonathan, commissioned the Orient Petroleum facility), Nmiata, Odekpe, Osomala, Osuche, Atani, Amii, Umuzu, and other communities in Anambra state were under water. Properties that worth billions of naira in the four local government areas of Anambra state, where these communities were situated, were destroyed by the flood. According to the Vanguard of 7th October 2012, the governor was able to persuade the people to leave their properties and secure their lives. He, the then Governor Peter Obi, thereafter used canoe to visit other communities trapped across the River Niger basin of Anambra state. By the time the then governor Peter Obi returned to his entourage to continue his inspection of other affected communities, flood had already filled the whole road through which he would leave. The governor and his entourage had to walk through the flood (Fig. 5a), which leveled-up to their waists, in order to reach the convoy of vehicles. On 1st through to 4th October 2012, all the communities along the River Benue axis were still under the influence of extreme low level moisture flux convergence. This implied that the communities would have experienced continuous heavy precipitation during these periods, apart from the water that was released from the lagdo dam (see Fig. 6) in Cameroon.



**Fig. 5** Situations during the 2012 flood in Anambra state (a and b). (Source: Emmanuel et al. 2015)



**Fig. 6** Map showing Nigeria, Cameroon, Benue River, and Lake Lagdo in Cameroon (<http://en.wikipedia.org/wiki/>). (Source: Agada (2015))

It was also reported (Vanguard, October 7, 2012), that about 79, 000 people were displaced in Cross River State. Out of the number, more than half – 49, 918 – were displaced by flood as a result of the release of water from Lagdo Dam in Cameroon. In Ikom Local Government Area, close to the community where the peak rainfall was observed on 29th September 2012, the flood also displaced 26 communities and destroyed one school and two markets.

The stability of the environment, on 28th September 2012 indicated that the entire zone under investigation was extremely unstable, particularly during the evening time (18Z) of the day that preceded the MCS event that was captured by TRMM satellite. It clearly showed that the Ofutop II community in Cross River was extremely unstable during the evening period of 28th September 2012 and during the night (0Z) of September 29, 2012 (the day the MCS was captured by TRMM satellite). During the morning time (6Z), the instability of the environment in Ofutop II of Cross River state had subsided to moderate category, but increased again to severe category during the day (12Z) and evening (18Z) periods. On September 30, 2012, the day that preceded the governor's visit to communities, Aguleri in Anambra state was under extreme instability during the evening period (18Z). Places like Makurdi and Katsina Ala in Benue state were also under extreme instability during the same evening diurnal. On 1st through to 4th October 2012, most communities in the affected zone were under moderate to extreme instability as indicated by the lifted index, particularly during the night (0Z), day (12Z) and evening (18Z) periods. The morning diurnals showed weaker instabilities in most cases during these periods (1st – 4th October, 2012).

On the 28th of September 2012, there was severe – extreme – wind shear in the environment of the event, which cut across the seven communities under investigation in this work. The most extreme wind shear was observed in Lokoja of Kogi state during the evening period (18Z) of 28th September 2012, which was earlier observed during the night period (6Z) of the same day. Lokoja was under the influence of extreme low level vertical wind the second day, 29th September 2012 during the night (0Z) and evening (18Z) periods. Because the entire Nigeria savannah environment was under the influence of strong moisture convergence during this period, hence the presence of cool pool dynamics in combination with the extreme low level vertical wind shear, among other factors would definitely had initiated deep convective systems, particularly in Lokoja and surrounding Benue state. Ofutop II and surrounding Ikom, in Cross River state, were particularly under the influence of severe low level vertical wind shear on the 28th September 2012 in all the periods. On 29th and 30th September 2012, the low level vertical wind shear in Ofutop II was already suppressed. It was noted that Lokoja in Kogi state and Makurdi in Benue state were still under the influence of extreme low level vertical wind shear on 30th September 2012. On 1st of October 2012, all the Nigeria savannah communities under investigation were influenced by extreme low level vertical wind shear. This convective environment remained under the influence of extreme low level vertical wind shear during 2nd, 3rd, and 4th of October 2012. Agada (2015) stated that the two most affected areas were Kogi and Benue States.

Results for the Ofutop II community where the peak rainfall rate was captured by the TRMM satellite showed that the Convective Available Potential Energy (CAPE) environment was positive (+) for the night time (0Z) on the 28th September 2012, with the peak mean CAPE value (4672.80 J/kg) and highest cloud top (slightly above 15 km) indicated by the evening time (18Z). During the night time (0Z) of 29th September 2012, which was the diurnal that preceded the morning time (0Z) of 29th September 2012 when the MCS system was captured, the top of the cloud as





**Fig. 7** Areal view of Lokoja, Kogi State, under the siege of flood. (Source: Vanguard 2012)

shown by the skew-t diagram was around 14–15 km, quite different from the height estimated by the TRMM satellite in the cross section plot, because the location (Ofutop II in Cross River state) under investigation is different from the nadir latitude–longitude of observation by the TRMM satellite. The mean CAPE value dropped significantly during the morning (6Z), day (12Z), and evening (18Z) periods of the same day but increased during the day (12Z) and evening (18Z) periods (12Z and 18Z) of the second day, which was 30th September 2012.

According to Vanguard (2012), horror came in the shape of suicide in one of the resettlement camps in Kogi State where two victims of the ravaging floods decided to take their own lives. They could not bear the loss of properties (Vanguard 2012). In relief camps in Kogi, 20 people have already died. The conditions were worst, two bags of rice for 2000 victims per day: How would it go round? The flood ravaged Lokoja (Vanguard 2012) as shown in Fig. 7 above.

---

## Conclusions

A combination of TRMM observed convective properties and reanalysis dataset have provided valuable information for analyzing flood scenarios in West Africa and have proved reliable based on the results generated from this research work.

At the time of written this chapter, flood disasters has become a yearly occurrence in all the locations affected by the 2012 Nigerian flood. There is no specific climate change adaptation strategies adopted in any of these locations. The inhabitants watched their properties and farmlands destroyed every year. There cry had always been to the government, but in all, relief materials are what they get in return.

Because this climate change hazard has become an annual occurrence in some parts of Nigeria and West Africa in general, this work therefore suggest that governments in affected countries put in place mitigation strategies to reduce the impact of future occurrence.

**Acknowledgements** This research was supported by Tertiary Education Trust Fund (TETFund) grant of the Nigerian government under the academic staff development program of the Federal University of Technology Akure for a split-site research program with the Texas A & M University Corpus Christi United States. Special thanks to Dr. Chuntao Liu, who granted me access to the Precipitation Feature database at Texas A & M University Corpus Christi United States.

## References

- Agada S (2015) A serious flooding event in Nigeria in 2012 with specific focus on Benue State: a brief review. *Nat Hazards* 77:1405–1414. <https://doi.org/10.1007/s11069-015-1639-4>
- Akaeze A (2012) An avoidable disaster. Tell special report, October 8, 2012.
- Balogun RA, Liu C, Debo AZ, Okogbue EC, Adesanya AE (2018) Intraseasonal and seasonal variability of convective properties of monsoon precipitation systems over West and Central Africa. *Theor Appl Climatol*. <https://doi.org/10.1007/s00704-018-2692-1>
- Charba J (1974) Application of gravity current model to analysis of squall-line gust front. *Mon Weather Rev* 102(2):140–156
- Chen Q, Fan J, Hagos S, Gustafson WI Jr, Berg LK (2015) Roles of wind shear at different vertical levels: cloud system organization and properties. *J Geophys Res Atmos* 120:6551–6574. <https://doi.org/10.1002/2015JD023253>
- Coniglio MC, Stensrud DJ, Wicker LJ (2006) Effects of upper-level shear on the structure and maintenance of strong quasi-linear mesoscale convective systems. *J Atmos Sci* 63(4):1231–1252. <https://doi.org/10.1175/jas3681.1>
- Dee DP et al (2011) The ERA-Interim reanalysis: configuration and performance of the data assimilation system. *Q J Roy Meteor Soc* 137:553–597
- DeLonge MS, Fuentes JD, Chan S, Kucera PA, Joseph E, Gaye AT, Daouda B (2010) Attributes of mesoscale convective systems at the land-ocean transition in Senegal during NASA African monsoon multidisciplinary analyses 2006. *J Geophys Res* 115:D10213. <https://doi.org/10.1029/2009JD012518>
- Droegemeier KK, Wilhelmson RB (1985) Three-dimensional numerical modeling of convection produced by interacting thunderstorm outflows. Part I: control simulation and low-level moisture variations. *J Atmos Sci* 42(22):2381–2403. [https://doi.org/10.1175/1520-0469\(1985\)042<2381:TDNMOC>2.0.CO;2](https://doi.org/10.1175/1520-0469(1985)042<2381:TDNMOC>2.0.CO;2)
- Emmanuel Udo A, Ojinnaka OC, Baywood CN, Gift UA (2015) Flood hazard analysis and damage assessment of 2012 flood in Anambra state using GIS and remote sensing approach. *Am J Geogr Inform Syst* 4(1):38–51. <https://doi.org/10.5923/j.ajgis.20150401.03>
- Galvin JFP (2010) Two easterly waves in West Africa in summer 2009. *Weather* 65(8):219–227. <https://doi.org/10.1002/wea.605>.
- GBF, WB, UN (2010) Inondations du 1er Septembre 2009 au Burkina Faso: evaluation des dommages, pertes et besoins de construction, de reconstruction et de relevement (Vol. 56803 BF). Government of Burkina Faso, World Bank, United Nations
- Goff RC (1976) Vertical structure of thunderstorm outflows. *Mon Weather Rev* 104(11):1429–1440. [https://doi.org/10.1175/1520-0493\(1976\)104<1429:VSOTO>2.0.CO;2](https://doi.org/10.1175/1520-0493(1976)104<1429:VSOTO>2.0.CO;2)
- Ismail P, Siadari EL (2017) Atmospheric conditions analysis of the heavy rain phenomenon in Biak (case study 4–5 December 2014). *J Phys Conf Ser* 795:012015
- Karambiri H (2009) Breve analyse frequentielle de la pluie du 1er septembre 2009 a Ouagadougou (Burkina Faso). Ouagadougou: 2iE.

- Langhans W, Roms DM (2015) The origin of water vapor rings in tropical oceanic cold pools. *Geophys Res Lett* 42:7825–7834. <https://doi.org/10.1002/2015GL065623>
- Magami I, Yahaya S, Mohammed K (2014) Causes and consequences of flooding in Nigeria: a review. *Biol Environ Sci J Tropics* 11(2):154–162
- Merem E, Twumasi Y, Wesley J, Alsarari M, Fageir S, Crisler M, Romomo C, Olagbegi D, Hines A, Ochai G, Nwagboso E, Leggett S, Foster D, Purry V, Washington J (2019) Regional assessment of climate change hazards in Southern Nigeria with GIS. *J Saf Eng* 8(1):9–27
- Moncrieff MW (1992) Organized convective systems: archetypal dynamical models, mass and momentum flux theory, and parametrization. *Q J R Meteorol Soc* 118(507):819–850. <https://doi.org/10.1002/qj.49711850703>
- NIMET (2012) Seasonal rainfall prediction and socio-economic implications for Nigeria, Nigerian meteorological agency. <http://nimet.gov.ng/sites/default/files/publications/2012-seasonal-rain-fall-prediction.pdf>
- Njoku J (2013) 2012 year of flood fury: a disaster foretold, but ignored? *Vanguardngrnews*, Saturday August 17, 2013.
- Ojobor L (2014) The 2012 flood disaster in Nigeria: impact on the operations of small scale business women in Igboland. *Int J Bus Manag Stud* 3(1):463–481
- Post-Disaster Needs Assessment 2012 Floods (2013) A report by the Federal Government of Nigeria with technical support from the World Bank, EU, UN, and Other Partners
- Richardson YP, Droegemeier KK, Davies-Jones RP (2007) The influence of horizontal environmental variability on numerically simulated convective storms. Part I: variations in vertical shear. *Mon Weather Rev* 135(10):3429–3455. <https://doi.org/10.1175/mwr3463.1>
- Robe FR, Emanuel KA (2001) The effect of vertical wind shear on radiative–convective equilibrium states. *J Atmos Sci* 58(11):1427–1445. [https://doi.org/10.1175/1520-0469\(2001\)058<1427:teovws>2.0.co;2](https://doi.org/10.1175/1520-0469(2001)058<1427:teovws>2.0.co;2)
- Rotunno R, Klemp JB, Weisman ML (1988) A theory for strong, long-lived squall lines. *J Atmos Sci* 45(3):463–485. [https://doi.org/10.1175/15200469\(1988\)045<0463:atfsl>2.0.co;2](https://doi.org/10.1175/15200469(1988)045<0463:atfsl>2.0.co;2)
- Schlef K (2018) Flood risk assessment, management and perceptions in a changing world. Doctoral dissertations. 1273. [https://scholarworks.umass.edu/dissertations\\_2/1273](https://scholarworks.umass.edu/dissertations_2/1273)
- Simmons A, Uppala S, Dee D, Kobayashi S (2007) ERA-interim: new ECMWF reanalysis products from 1989 onwards. *ECMWF Newsl* 110:25–35
- Simpson JE (1969) A comparison between laboratory and atmospheric density currents. *Q J R Meteorol Soc* 95(406):758–765. <https://doi.org/10.1002/qj.49709540609>
- Takemi T (2006) Impacts of moisture profile on the evolution and organization of midlatitude squall lines under various shear conditions. *Atmos Res* 82(1–2):37–54. <https://doi.org/10.1016/j.atmosres.2005.01.007>
- Tompkins AM (2001) Organization of tropical convection in low vertical wind shears: the role of cold pools. *J Atmos Sci* 58(13):1650–1672. [https://doi.org/10.1175/15200469\(2001\)058<1650:OOTCIL>2.0.CO;2](https://doi.org/10.1175/15200469(2001)058<1650:OOTCIL>2.0.CO;2)
- Vanguard Newspaper (2012) Rage of nature: flood ravages communities across Nigeria. 7th October 2012
- Warner C, Simpson J, Van Helvoirt G, Martin DW, Suchman D, Austin GL (1980) Deep convection on day 261 of GATE. *Mon Weather Rev* 108(2):169–194. [https://doi.org/10.1175/1520-0493\(1980\)108<0169:DCODOG>2.0.CO;2](https://doi.org/10.1175/1520-0493(1980)108<0169:DCODOG>2.0.CO;2)
- WB (2017) Burkina Faso overview. Retrieved January 1, 2017, from <http://www.worldbank.org/en/country/burkinafaso/overview>
- Weisman ML, Rotunno R (2004) “A theory for strong long-lived squall lines” revisited. *J Atmos Sci* 61(4):361–382. [https://doi.org/10.1175/15200469\(2004\)061<0361:atfsls>2.0.co;2](https://doi.org/10.1175/15200469(2004)061<0361:atfsls>2.0.co;2)
- Wu X, Yanai M (1994) Effects of vertical wind shear on the cumulus transport of momentum: observations and parameterization. *J Atmos Sci* 51(12):1640–1660. [https://doi.org/10.1175/1520-0469\(1994\)051<1640:eovwso>2.0.co;2](https://doi.org/10.1175/1520-0469(1994)051<1640:eovwso>2.0.co;2)
- Xu K-M, Arakawa A, Krueger SK (1992) The macroscopic behavior of cumulus ensembles simulated by a cumulus ensemble model. *J Atmos Sci* 49(24):2402–2420. [https://doi.org/10.1175/1520-0469\(1992\)049<2402:tmboce>2.0.co;2](https://doi.org/10.1175/1520-0469(1992)049<2402:tmboce>2.0.co;2)

**Open Access** This chapter is licensed under the terms of the Creative Commons Attribution 4.0 International License (<http://creativecommons.org/licenses/by/4.0/>), which permits use, sharing, adaptation, distribution and reproduction in any medium or format, as long as you give appropriate credit to the original author(s) and the source, provide a link to the Creative Commons license and indicate if changes were made.

The images or other third party material in this chapter are included in the chapter's Creative Commons license, unless indicated otherwise in a credit line to the material. If material is not included in the chapter's Creative Commons license and your intended use is not permitted by statutory regulation or exceeds the permitted use, you will need to obtain permission directly from the copyright holder.





# Differential Impact of Land Use Types on Soil Productivity Components in Two Agro-ecological Zones of Southern Ghana

# 84

Folasade Mary Owoade, Samuel Godfried Kwasi Adiku, Christopher John Atkinson, and Dilys Sefakor MacCarthy

## Contents

Introduction .....	1722
Materials and Methods .....	1723
Sites .....	1723
Sampling and Analysis .....	1726
Statistical Analysis .....	1726
Results and Discussions .....	1728
Effect of Site Locations on Soil Properties .....	1728
Conclusion .....	1731
References .....	1731

This chapter was previously published non-open access with exclusive rights reserved by the Publisher. It has been changed retrospectively to open access under a CC BY 4.0 license and the copyright holder is “The Author(s)”. For further details, please see the license information at the end of the chapter.

F. M. Owoade (✉)

Department of Crop Production and Soil Science, Ladoke Akintola University of Technology, Ogbomoso, Nigeria

e-mail: [fmowoade@lautech.edu.ng](mailto:fmowoade@lautech.edu.ng)

S. G. K. Adiku

Department of Soil Science, University of Ghana, Legon, Ghana

e-mail: [s\\_adiku@ug.edu.gh](mailto:s_adiku@ug.edu.gh)

C. J. Atkinson

Natural Resources Institute, University of Greenwich, London, UK

Department of Agriculture, Health and Environment, Natural Resources Institute, University of Greenwich, Chatham, UK

e-mail: [C.J.Atkinson@greenwich.ac.uk](mailto:C.J.Atkinson@greenwich.ac.uk)

D. S. MacCarthy

Soil and Irrigation Research Centre Kpong, University of Ghana, Accra, Ghana

e-mail: [dsmacCarthy@gmail.com](mailto:dsmacCarthy@gmail.com)

© The Author(s) 2021

W. Leal Filho et al. (eds.), *African Handbook of Climate Change Adaptation*, [https://doi.org/10.1007/978-3-030-45106-6\\_144](https://doi.org/10.1007/978-3-030-45106-6_144)

1721

---

**Abstract**

The maintenance of soil productivity is important for sustained crop yield in low-input systems in the tropics. This study investigated the impact of four different land use types, namely, maize and cassava cropping, woodlot/plantations, and natural forests on soil productivity components, especially soil carbon accretion, at six sites within two agro-ecological zones of southern Ghana. Soil properties were significantly different between sites and ecological zones. The coastal savanna zones, which is a low rainfall zone had relatively lower soil carbon storage than the high rainfall forest-savanna transition zone. Soil productivity conditions in the later zone were much more favorable for cropping than the former. Land use types significantly affected the soil carbon (*SOC*) storage within the two ecological zones. In the low rainfall zone, soil carbon accretion by maize cropping, cassava cropping, and plantations were 48%, 54%, and 60%, respectively, of the forest carbon stock (47,617 kg/ha). In the transition zone, the soil carbon accretion was over 90% of the forest value (48,216 kg/ha) for all land use types. In effect use of land use types in maintaining soil productivity must consider the conditions in a given ecological zone.

---

**Keywords**

Agro-ecology · Land use · Soil carbon stock · Soil productivity · Soil properties

---

**Introduction**

Soil organic carbon (*SOC*) is a major component of productivity in low-input cropping systems of the tropics. Soil carbon influences the physical, chemical, and biological properties of the soil. Many studies have indicated that the reduction in the *SOC* can result in significant decrease in the available water capacity (Hudson 1994), structural deterioration, and an increased bulk density (Shu et al. 2015). Also, the contribution of the *SOC* to soil fertility maintenance is also well established. Crop yield reduction is often associated with *SOC* losses, largely because the *SOC* is a major reservoir of nutrients, especially in the tropics where external inputs continue to remain low (Sanchez et al. 2009). Estimates by Lal (2006) indicated that maize yield could decline by 30–300 kg ha<sup>-1</sup> for every ton ha<sup>-1</sup> of *SOC* in the root zone. Regarding soil biology, the *SOC* is a major source of nutrition and energy for microbial life. Some authors describe the *SOC* as the “... life blood” of tropical soils (Acquaye 1989). Though the *SOC* plays a dominant role in tropical agriculture, other soil properties may also enhance the overall productivity. Nutrients elements such as nitrogen, which is largely derived from organic matter mineralization, phosphorus from rock minerals, and the overall cation retention capacity are important factors that also determine soil and crop productivity.

Soil carbon and hence productivity is not permanent but may change rapidly depending on land use type and management (Zerihun 2017; Waddington et al.

2010; Reynolds et al. 2015). Much of the literature (Burras et al. 2001; Sa et al. 2001; Batlle-Aguilar et al. 2011) indicates that the conversion of forest to agriculture and other forms of land use such as plantations and woodlots is the major cause of soil productivity decline in the tropics. Brams (1971) showed a 50% reduction in the *SOC*, only 5 years after forest clearing in Sierra Leone.

Residue management methods employed in agriculture also lead to changes in *SOC*. Adiku et al. (2009) showed in Ghana that where crop residues were removed (e. g., by burning, or cutting to feed animals with no return of manure), the *SOC* declined rapidly from the long-term fallow land value of  $18 \text{ g kg}^{-1}$  to  $7 \text{ g kg}^{-1}$  with 4 years of maize cropping. However, where the residues were maintained as mulch, the rate of *SOC* decline was much slower, from  $18 \text{ g kg}^{-1}$  to  $15 \text{ g kg}^{-1}$  over years. A greater buildup of *SOC* in forests than other land use types would be expected because of long-term continuous litter addition (Brinson et al. 1980), for example, by avoidance of cultivation losses and reduced decomposition due to lower temperatures under a tree canopy. For croplands, the constant disturbance of the soil enhances *SOC* decomposition (Lal 1997; Hulgalle et al. 1984; Kang 1993; Dalal et al. 1991), and the constant harvest or removal of plant organic material (Feller 1993) would increase the *SOC* loss due to the partial exposure of the soil to high temperatures during off-seasons.

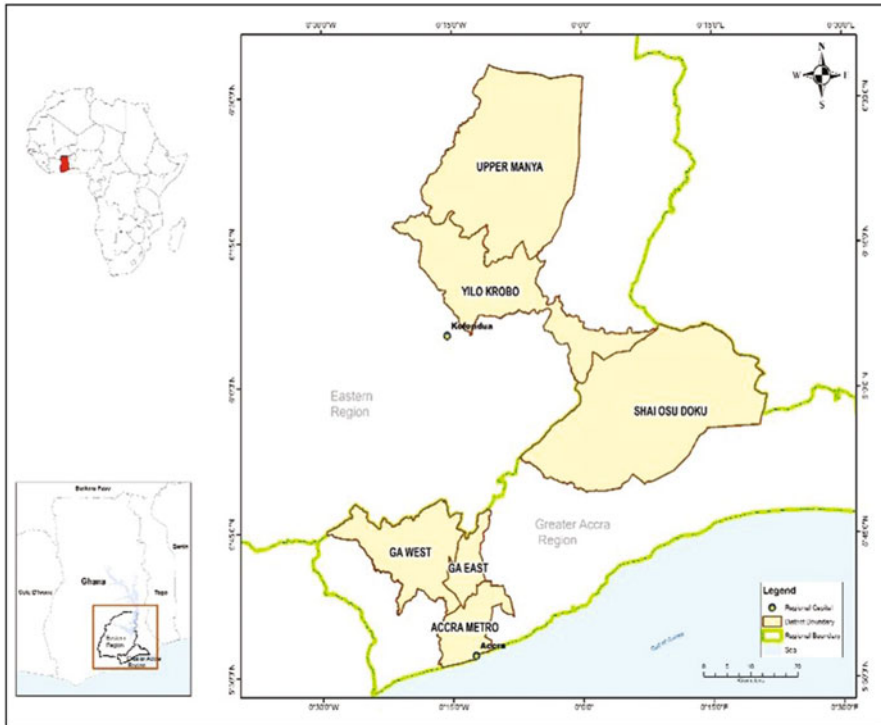
Despite these findings, the manner in which land use types affect soil carbon storage in different ecological zones is not well understood. The question of interest here is whether a given land use type will equally impact soil properties in different rainfall and vegetation zones. In other words, can we generalize that cropping will adversely affect soil productivity irrespective of the carbon input capacity of different ecological zones? This aspect of research is still lacking in Ghana, even though it has relevance for the design and management of soil productivity. The focus of this chapter is to examine how four land use types (forest, woodlot/plantation, cassava cropping, and maize cropping) affect soil carbon content and other properties at six farming sites of Ghana (across two ecological zones).

---

## Materials and Methods

### Sites

Six (6) farming sites from two agro-ecological zones, all in southern Ghana, were selected for this study (Fig. 1). Three of the farming sites (Accra Metropolis, Ga East District, Ga West District) fall in the coastal savanna zone of Ghana and receives 650–1000 mm rainfall. Though the vegetation is largely grassland, some derived savanna locations still host original pockets of forestland. The dominant soil type of the Greater Accra Region based on FAO/UNESCO classification is Ferric Acrisol and Umbic Leptosol (Soil Research Institute 1999). The remaining three sites (Yilo Krobo District, Shai Osudoku District, and Upper Manya District) fall within the forest-savanna transition zone (hereinafter transition zone) receiving 1500–2000 mm rainfall. Vegetation is largely forest at some portions and mixed with grassland in other portions. The soils of the transition comprise Cambic Arenosol and Calcic



**Fig. 1** Map shows position of Ghana in West Africa (top left), the location of the study sites in southern Ghana (bottom left), and the details of the districts (Ga West, Ga East, Accra Metropolis, Yilo Krobo, Shai Osudoku, and Upper Manya) used in Ghana

vertisol. Rainfall in both ecological zones is bimodally distributed, with a major wet season from March to July and a minor wet season from September to November. Agriculture is the main source of livelihood at all the sites.

The first site (Accra Metropolis) in the coastal savanna zone was located at the University of Ghana Farm and hosts a forest of more than 150 years old. Nearby the forest is cleared area which has been cropped to maize (*Zea mays*) and cassava (*Manihot esculenta*) for more than 20 years by University Farm workers. The maize fields receive periodically modest fertilizer application of not more than  $30 \text{ kg N ha}^{-1}$ . Also, located at the University Farm is an 18-year-old woodlot of *Leucaena species* established on a previously cropped land. Experimental plots at the University Farm were not included in this study. The soils under the forests and woodlots have little mechanical disturbance for many years, but the croplands are plowed and cultivated annually. The second site in this zone (Abokobi) also carried a 70-year-old forest with adjacent lands cropped to maize and cassava for not more than 10 years. A plantation of plantain (*Musa spp.*) was established near the forest. The third site (Pokuase) carried a forest of more than 70 years, an oil palm (*Elaeis guineensis*) plantation as well as cassava and maize farms.



The fourth site (Yilo Krobo), which is located in the transition zone carried a forest of more than 50 years, an oil palm plantation and relatively young crop farms of maize and cassava. The fifth site (Shai Osudoku) holds a protected forest with mature trees of more than 100 years old. For this reason, soil sampling was restricted to the fringes of the forest. Other land use systems at this site include an 18-year mango (*Mangifera indica*) plantation, maize, and cassava farms. The sixth site (Upper Manya) has a forest of more than 50 years old, along with oil palm plantations, and recent arable farms.

**Table 1** Land use types at the two agroecological zones

Site	Ecology	Rainfall (mm)	Dominant soil	Land use	Age (years)
Accra-Metropolis	Coastal savannah	700	Ferric Acrisol	Maize	10
				Cassava	10
				Woodlot	20
				Forest	>150
Ga-East	Coastal savannah	800	Ferric Acrisol	Maize	5
				Cassava	8
				Plantation	6
				Forest	>70
Ga-West	Coastal savannah	800	Umbic Leptosol	Maize	4
				Cassava	10
				Plantation	10
				Forest	>70
Yilo Krobo	Forest savannah	900–;1500	Calcic Vertisol	Maize	10
				Cassava	8
				Plantation	23
				Forest	>60
Shai-Osudoku	Forest savannah	900–1500		Maize	>50
				Cassava	>50
				Plantation	18
				Forest	>100
Upper-Manya	Forest savannah	900–1500	Cambic Arenosol	Maize	5
				Cassava	7
				Plantation	10
				Forest	>50

Farmers' best estimates

## Sampling and Analysis

For this study, four land use types, namely, maize cropping, cassava cropping, plantations (teak, mango, plantain, oil palm, woodlot), and natural forests were selected (Table 1). Fifty-four (54) farms across the six sites were selected and visited from April to May 2017, and soils were sampled from each land use type from the depth of 0–20. The cropping history of the 54 farms were documented during a prior survey by Owoade et al. (2017). At each site, at least three maize and three cassava farms were sampled in triplicates and bulked to obtain a composite sample for each farm. In addition, soils were sampled from the plantations and the natural forests.

The disturbed top soil (0–20 cm) and separately sampled undisturbed soil cores were brought to the laboratory for analysis. The bulk density was determined on the soil cores. Disturbed soils were air-dried, crushed, and sieved through 2-mm sieve for the determination of texture, total soil carbon, pH, total nitrogen, available phosphorus, and exchangeable cations (K, Mg, Ca, Na). Exchangeable bases were determined by extraction with 250 ml of buffered 1.0 M ammonium acetate followed by flame photometric determination and the effective cation exchange capacity (ECEC) was determined as the sum of exchangeable cations. Soil texture determination followed the procedure of Bouyoucos (1951) as modified by Day (1965) using sodium hexametaphosphate as the dispersant. Soil pH was determined in 1:1 soil to water ratio using a MV88 Praitronic pH meter and electrode. Available phosphorus (AvP) was determined colorimetrically after extraction with Bray 1 solution (Bray and Kurtz 1945) and the concentration measured using a UV-Spectrophotometer. Total soil carbon and nitrogen were determined using TruMac Carbon, Nitrogen, and Sulfur analyzer (Model N1914).

The soil carbon content was converted to stocks ( $C_{st}$ ) using:

$$C_{st} = A \times \rho_b \times z \times SOC \quad (1)$$

where  $A$  is the land area (1 ha =  $10^4$  m<sup>2</sup>),  $\rho_b$  is the soil bulk density (kg/m<sup>3</sup>), and  $z$  is the soil depth (0.20 m).

## Statistical Analysis

Analysis of variance was conducted using MINITAB software to determine the influence of land use types and site location on soil properties.

**Table 2** Variation of soil properties with sites

Site	Ecology	Bulk density (g/cm <sup>3</sup> )	SOC (g/kg)	pH	Avail P (mg/kg)	N (mg/kg)	ECEC (cmol/kg)
Accra Metropolis	Coastal savanna	1.27 ± 0.16	12.4 ± 6.0	4.4 ± 0.4	18.7 ± 12	4.3 ± 0.4	3.11 ± 0.86
Ga East		1.38 ± 0.10	11.49 ± 5.0	5.05 ± 0.5	10.9 ± 6.0	4.1 ± 0.3	3.06 ± 0.91
Ga West		1.29 ± 0.14	15.6 ± 8.6	5.6 ± 0.54	10.8 ± 6.1	1.90 ± 0.9	4.12 ± 1.4
Yilo Krobo	Transition	1.19 ± 0.15	23.50 ± 6.5	6.15 ± 0.54	15.70 ± 4.3	1.20 ± 0.6	6.79 ± 2.16
Shai Osudoku		1.32 ± 0.07	18.20 ± 5.8	6.15 ± 0.39	12.90 ± 7.1	3.6 ± 2.2	6.64 ± 1.52
Upper Manya		1.29 ± 0.08	13.10 ± 2.7	6.03 ± 0.048	7.90 ± 4.2	1.80 ± 0.23	4.29 ± 1.5
p-value		0.007	0.000	0.000	0.008	0.000	0.000

## Results and Discussions

### Effect of Site Locations on Soil Properties

There were significant differences among some soil properties at the various sites (Table 2). For example, soil texture, expressed as clay ratio (sand + silt)/clay, differed significantly with site, with high values ( $>11$ ) at sites 1, 2, 5, and 6, and low values (4–5) at locations 3 and 4 (not shown). The bulk density differed significantly with site ( $p = 0.007$ ) with higher values observed for the coastal savanna zone (1.3–1.4 g/cm<sup>3</sup>) than in the transition zone (1.2–1.3 g/cm<sup>3</sup>). The *SOC* also differed significantly with site ( $p = 0.000$ ), with higher values in the transition zone (1.3–2.4 g/kg) than the coastal savanna zone (1.2–1.6 g/kg). Apparently, the higher *SOC* of the transition zone could be attributed to a greater carbon input by the high rainfall and more forest vegetation than the savanna ecological zone. The higher *SOC* of the transition zone may explain, the lower bulk density values, as these two properties are inversely related.

The pH differed significantly ( $p = 0.000$ ) between ecological zones with the transition zone having higher values (6.0–6.2) than the coastal savanna (4.4–5.6). Soil pH differences may have consequences to crop performance because most nutrient elements are usually available in the pH range of 5.5–6.5 (Motsara and Roy 2008). The available P was significantly different ( $p = 0.008$ ) among the sites. Though site 1 (Accra Metropolis) in the coastal savanna zone had the highest value (18.7 mg/kg), and the variability was also very high (SD = 12 mg/kg). Except for the site 6 (Upper Manya) which had the lowest available P (7.9 mg/kg), the average P values were quite similar for the two ecological zones; 11–18 mg/kg for the coastal savanna and 8–16 mg/kg for the transition zone. In general, the available P levels were somewhat adequate for plant growth, given a threshold of 11 mg/kg (Adeoye and Agboola 1985). Total nitrogen values varied significantly with site ( $p = 0.000$ ) with higher values for the coastal savanna (1.1–4.3 mg/kg) than the transition zone (1.2–3.6 mg/kg). Though the ECEC can be considered as generally low but differed significantly ( $p = 0.000$ ) between ecological zones, with the transition zone having 4.3–6.8 cmol/kg and the coastal savanna having 3.1–4.1 cmol/kg. Based on the soil property values, it may be concluded that the transition zone provided a much better soil condition for cropping than the coastal savanna zone.

Not all the soil properties were significantly affected by land use type. Across all sites, land use type had significant ( $p = 0.003$ ) effect on the *SOC*, with a clear-cut difference between the *SOC* of the forest (21 g/kg) and the rest of the land use types where the *SOC* ranged from 13.0 (maize) to 14.0 (woodlot/plantation) g/kg (Table 3). Land use type also had significant effect ( $p = 0.000$ ) on the bulk density, with the forests having the lowest value (1.2 g/cm<sup>3</sup>) and maize farms having the highest (1.34 g/cm<sup>3</sup>). There were no significant effects of land use types on available P, N, ECEC, or pH.

The interactive effects between sites and land use type were only significant for the *SOC* and bulk density. Incidentally, these two properties are the major determinants of the total carbon stock (Eq. 1). Land use type significantly ( $p = 0.013$ ) affected the total carbon stocks at the various sites in the order: forest > plantation > cassava > maize. Across the sites, the forest soils had the highest average storage of  $48,216 \pm 12,811$  kg/

**Table 3** Variation of soil properties with land use types

Land use	Bulk density (g/cm <sup>3</sup> )	SOC (g/kg)	pH	Avail P (mg/kg)	N (mg/kg)	ECEC (cmol/kg)
Maize	1.34 ± 0.15	13.0 ± 7.40	5.6 ± 0.79	14.8 ± 7.7	2.50 ± 1.3	4.60 ± 0.1.6
Cassava	1.29 ± 0.08	15.00 ± 6.4	5.70 ± 0.82	11.61 ± 7.0	2.90 ± 1.4	4.60 ± 2.4
Plantation	1.32 ± 0.14	14.0 ± 5.90	5.60 ± 0.82	11.80 ± 6.3	3.00 ± 1.3	4.40 ± 1.7
Forest	1.20 ± 0.10	20.9 ± 6.9	5.30 ± 0.71	13.10 ± 10	2.70 ± 2.3	5.10 ± 2.5
p-value	0.005	0.003	NS	NS	NS	NS

**Table 4** Land use effects on soil carbon stocks

Region	Land use	Carbon stock (kg/ha)	% Forest carbon
Coastal savanna			
	Maize	24,316 ± 12,155	48
	Cassava	27,671 ± 10,839	54
	Woodlot	30,325 ± 4450	60
	Forest	50,491 ± 12,755	–
Forest-savanna transition			
	Maize	41,897 ± 12,263	88
	Cassava	43,001 ± 10,007	91
	Plantation	45,019 ± 14,786	95
	Forest	47,382 ± 20,252	–

ha “..(not shown) 4” followed by plantations (36,774 ± 14,482 kg/ha), cassava (35,007 ± 14,014 kg/ha), and maize (33,905 ± 12,811 kg/ha). Other studies (Djagbletey et al. 2018) have also reported higher soil carbon stocks for denser forests in the Guinean savanna zone of Ghana. In other works, carbon stocks as high as 59,450 kg/ha determined for forest soils in the semi-deciduous forest zone of Ghana by Dawoe (2009).

With regard to ecological zones, the results showed that the differences in land use impact on soil carbon in the transition zone was smaller than in the coastal savanna zone (Table 4). In the coastal savanna zone, maize accrued 48% of the forest carbon stock, while the cassava and plantation accrued 54% and 60%, respectively, suggesting that the plantations were most effective in soil carbon restoration. With regard to the transition zone, however, the soil carbon restoration effectiveness was generally high 90–95% for all the land use types. Though the plantations impact was again the highest, values above 90% accretion generally suggests that all the land use types were equally effective.

Options for *SOC* accretion must consider the differential effects of land use types as well as ecological zones. Our observations indicated that cropping of the land depleted the *SOC* the most. The reduction of *SOC* stocks on cropped lands can be attributed to factors such as the harvest removal of plant organic matter (Feller 1993), constant disturbance of the soil that enhances decomposition (Lal 1999; Hulugalle et al. 1984; Kang 1993; Dalal et al. 1991), and the partial exposure of soil to high temperatures during off-seasons when vegetation cover is reduced. These researchers (Yilfru and Taye 2011; Caravaca et al. 2002; Malo et al. 2005) also recorded greater *SOC* in forest compared to cultivated land. Though our sampling did not include intercropping systems, the observation that cassava cropping accrued high carbon stock than maize suggests that a maize-cassava intercropping could, perhaps, maintain a higher carbon addition, because of the longer life cycle of cassava and higher *SOC* accretion than maize.

The plantation land use type showed a higher *SOC* accretion but would require relatively long periods of time to achieve, thus preventing cropping of the lands for some time. Presumably, a combination of plantation and cropping is desired to ensure both crop productivity as well as *SOC* maintenance. This can be accomplished by agroforestry, which has been promoted in many parts of the tropics to enhance crop

yields (Kang 1993), but the adoption rates have continued to be very low. Apparently, the competition between live trees and crops for resources in agroforestry systems can reduce crop productivity (Ong et al. 1991), thereby handicapping the adoption of the system by farmers. Tree-crop rotations, as practiced under the traditional shifting cultivation, could also be an effective alternative to agroforestry. The tree phase of the rotation would permit the rebuild of the *SOC* which is depleted during the cropping phase. This traditional shifting cultivation needs to be further researched for its role in soil carbon management and crop production.

---

## Conclusion

Soil productivity in Ghana is influenced by both land use type and agro-ecological zone. Findings from this study indicated that soil productivity conditions for agriculture were less favorable for agriculture in the coaster savanna than the forest-savanna transition zone. Furthermore, land use types had significant impact on the carbon storage, with maize-based cropping systems having the lowest carbon stocks. Woodlot/plantation types of land use restored the SOC and productivity more effectively than croplands. In effect, the effectiveness of land use systems for soil productivity maintenance differs with agro-ecological zones. This must be factored into the design of land management measures.

**Acknowledgment** This research is supported by funding from the UK's Department for International Development (DfID) under the Climate Impacts Research Capacity and Leadership Enhancement (CIRCLE) program implemented by the African Academy of Sciences and the Association of Commonwealth Universities.

---

## References

- Acquaye DK (1989) Towards the development of sustainable agriculture in Africa. Reflections of a soil scientist. In: Proceedings of the 11th and 12th general meeting, Soil Science Society of Ghana. University of Ghana, Accra, p 91
- Adeoye GO, Agboola AA (1985) Critical levels for soil pH, available P, K, Zn and Mn and maize ear-leaf content of P, Cu and Mn in sedimentary soils of South-Western Nigeria. *Nutr Cycl Agroecosyst* 6:65–71
- Adiku SGK, Jones JW, Kumaga FK, Tonyiga A (2009) Effects of crop rotation and fallow residue management on maize growth, yield and soil carbon in a savanna- forest transition zone of Ghana. *J Agric Sci* 147(3):313–322
- Battle-Aguilar B, Porporato A, Barry D (2011) Modelling soil carbon and nitrogen cycles during land use change. A review. *Agron Sustain Dev* 31(2):251–274
- Bouyoucos GH (1951) A calibration of the hydrometer for making mechanical analysis of soils. *Agron J* 43:434–438
- Brams EA (1971) Continuous cultivation of West African soils: organic matter diminution and effects of applied lime and phosphorus. *Plant Soil* 35:401–414. <https://doi.org/10.1007/BF01372671>
- Bray RH, Kurtz LT (1945) Determination of total, organic, and available forms of phosphorus in soil. *Soil Sci* 59:39–45

- Brinson M, Bradshaw HD, Holmes RN, Elkins JB Jr (1980) Litterfall, stemflow and throughfall nutrient fluxes in an alluvial swamp forest. *Ecology* 61:827–835
- Burras L, Kimble JM, Lal R, Mausbach MJ, Uehara G, Cheng HH, Kissel DE, Luxmoore RJ, Rice CW, Wilding LP (2001) Carbon sequestration: position of Soil Science Society of America. <http://www.soils.org/carbseq.html>
- Caravaca F, Masciandaro G, Ceccanti B (2002) Land use in relation to soil chemical and biochemical properties in a semi-arid Mediterranean environment. *Soil Tillage Res* 69(1):23–30. [https://doi.org/10.1016/s0167-1987\(02\)00080-6](https://doi.org/10.1016/s0167-1987(02)00080-6)
- Dalal RC, Strong WM, Weston EJ, Gaffney J (1991) Soil fertility decline and restoration of cropping lands in sub-tropical Queensland. *Trop Grasslands* 25:173–180
- Dawoe E (2009) Conversion of natural forest to cocoa agroforest in Lowland Humid Ghana: impact on plant biomass production, organic carbon and nutrient dynamics. PhD thesis, Department of Agroforestry, Kwame Nkrumah University of Science and Technology, Kumasi, 260 pp
- Day PR (1965) Particle fractionation and particle size analysis. In: Black CA et al (eds) *Methods of soil analysis, Part I. Agronomy, vol 9*. American Society of Agronomy, Madison, pp 545–567
- de Sa JCM, Cerri CC, Dick WA, Lal R, Venske-Filho SP, Piccolo MC, Feigl BE (2001) Organic matter dynamics and carbon sequestration rates for a tillage chronosequence in a Brazilian Oxisol. *Soil Sci Soc Am J* 65:1486–1499
- Djagbletey ED, Logah V, Ewusi-Mensah N, Tuffuour HO (2018) Carbon stocks in the Guinea savanna of Ghana: estimates from three protected areas. *Biotropica* 1–9. <https://doi.org/10.1111/btp.12529...org/10.5061/dryad.d1d30>
- Feller OE (1993) Organic input, soil organic matter and functional soil organic compartments in low-activity clay soils in tropical zones. In: Mulongoy K, Merckx R (eds) *Soil organic matter dynamics and sustainability of tropical agriculture*. Wiley, New York, pp 77–85
- Hudson BD (1994) Soil organic matter and available water capacity. *J Soil Water Conserv* 49:189–194
- Hulugalle NR, Lal R, Ter Kuille CHH (1984) Soil physical changes and crop root growth following different methods of land clearing in Western Nigeria. *Soil Sci* 138:172–179
- Kang BT (1993) Alley cropping: past achievements and future directions. *Agrofor Syst* 23(2-3):141–155. <https://doi.org/10.1007/BF00704912>
- Lal R (1997) Soil degradative effects of slope and maize monoculture effects on a tropical Alfisols in Western Nigeria and soil physical properties. *Land Degrad Dev* 8:325–342
- Lal R (1999) Soil management and restoration for C sequestration to mitigate the greenhouse effect. *Prog Environ Sci* 1:307–326
- Lal R (2006) Enhancing crop yields in the developing countries through restoration of soil organic carbon pool in agricultural lands. *Land Degrad Dev* 17:197–209
- Malo DD, Schumacher TE, Doolittle JJ (2005) Long term cultivation impacts on selected soil properties in the northern Great Plains. *Soil Tillage Res* 81:27–29
- Motsara MR, Roy RN (2008) Guide to laboratory establishment for plant nutrient analysis, FAO fertilizer and plant nutrition bulletin 19. FAO, Rome
- Ong CK, Corlett JE, Singh RP, Black CR (1991) Above and below ground interactions in agroforestry systems. *For Ecol Manag* 45:45–57
- Owoade FM, Adiku SGK, Atkinson CJ, Kolawole GO, MacCarthy DS, Narh S (2017) Residue retention practices for carbon sequestration in some Ghanaian soils: a survey of willingness towards climate change mitigation. In: *Proceedings of the international conference on climate change and sustainable development in Africa (ICCCSDA): climate change and sustainable development: strengthening Africa's adaptive capacity*. University of Energy and Natural Resources, Sunyani, 25–28 July 2017
- Reynolds TW, Waddington SR, Anderson CL, Chew A, True Z, Cullen A (2015) Environmental impacts and constraints associated with the production of major food crops in Sub-Saharan Africa and South Asia. *Food Sec* 7:795–822
- Sanchez P, Denning G, Nziguheba G (2009) The African green revolution moves forward. *Food Sec* 1:37–44



- Shu X, Zhu A, Zhang J, Yang W, Xin X, Zhang X (2015) Changes in soil organic carbon and aggregate stability after conversion to conservation tillage for seven years in the Hung-Huai-Hai Plain of China. *J Integr Agric* 14:1202–1211
- Soil Research Institute (1999) Soil map of Ghana, FAO/UNESCO (1990). Land suitability section. Soil Research Institute, CSIR, Accra
- Waddington SR, Li X, Dixon J, Hyman G, de Vicente MC (2010) Getting the focus right: production constraints for six major food crops in Asian and African farming systems. *Food Sec* 2:27–48
- Yilfru A, Taye B (2011) Effects of land use on soil organic carbon and nitrogen in soil of Bale, South eastern Ethiopia. *Trop Subtrop Agro Ecosyst* 14(1):229–235
- Zerihun T (2017) Raising crop productivity in Africa through intensification. *Agronomy* 7:22; 30. <https://doi.org/10.3390/agronomy7010022>

**Open Access** This chapter is licensed under the terms of the Creative Commons Attribution 4.0 International License (<http://creativecommons.org/licenses/by/4.0/>), which permits use, sharing, adaptation, distribution and reproduction in any medium or format, as long as you give appropriate credit to the original author(s) and the source, provide a link to the Creative Commons license and indicate if changes were made.

The images or other third party material in this chapter are included in the chapter's Creative Commons license, unless indicated otherwise in a credit line to the material. If material is not included in the chapter's Creative Commons license and your intended use is not permitted by statutory regulation or exceeds the permitted use, you will need to obtain permission directly from the copyright holder.





# Data Collection Using Wireless Sensor Networks and Online Visualization for Kitui, Kenya

# 85

Josephine Mbandi and Michael Kisangari

## Contents

Introduction: Background on Kitui County, Kenya .....	1736
Climate Change and its Impact in the Region .....	1736
Other Studies .....	1738
Methodology .....	1738
System Design .....	1741
System Implementation and Experiments .....	1743
Conclusion .....	1745
References .....	1746

## Abstract

Kenya is a developing country with a population of 47,213,282 people this comprises of 56% low-income earners. Small businesses and crop production represent 23% of the income within the country, which is at risk as soils become less productive. Various factors have led to this, climate change and land overuse being leading causes. Without adaptation, the rural to urban migration will continue to increase.

This chapter was previously published non-open access with exclusive rights reserved by the Publisher. It has been changed retrospectively to open access under a CC BY 4.0 license and the copyright holder is “The Author(s)”. For further details, please see the license information at the end of the chapter.

J. Mbandi (✉)

School of Computational and Communication Sciences and Engineering (CoCSE), Nelson Mandela Institution of Science and Technology (NM-AIST), Tengeru, Arusha, Tanzania  
e-mail: [mbandij@nm-aist.ac.tz](mailto:mbandij@nm-aist.ac.tz)

M. Kisangari

Centre of Excellence in Information Technology (CENIT@EA), Arusha, Tanzania  
e-mail: [Michael.kisangiri@nm-aist.ac.tz](mailto:Michael.kisangiri@nm-aist.ac.tz)

© The Author(s) 2021

W. Leal Filho et al. (eds.), *African Handbook of Climate Change Adaptation*,  
[https://doi.org/10.1007/978-3-030-45106-6\\_151](https://doi.org/10.1007/978-3-030-45106-6_151)

1735

Through Internet of Things (IoT) and specifically wireless sensor networks, we can change how we obtain and consume information. Small-scale farmers can collect data and in exchange receive useful information about their soils, temperature, humidity, and moisture content hence make better choices during crop production. Connected end devices bring in data, which is currently sparse in relation to small-scale farming. IoT will enable analysis and informed decision-making including crop selection, support equipment, fertilizers, irrigation, and harvesting. The cloud-based analysis will provide information useful for policy making and improvement.

This chapter presents a wireless sensor network (WSN) in mesh topography using XBee communication module, communication, and raspberry pi, combined with a cloud-based data storage and analysis. We successfully set up a proof of concept to test a sensor node that sends information to a RPi and onto an online visualization platform.

---

**Keywords**

IoT (Internet of Things) · WSN (wireless sensor networks) · Cloud computing · Climate change adaptation

---

**Introduction: Background on Kitui County, Kenya**

Kitui County is one of Kenya's 47 counties located in the lower eastern region of the country. The county has eight subcounties, namely, Kitui Central, Kitui South, Kitui East, Kitui Rural, Kitui West, Mwingi North, Mwingi West, and Mwingi Central. There are three livelihood zones in the county, marginal mixed farming, mixed farming livelihood zone, and formal employment, contributing 44%, 52%, and 4% of the population, respectively. The county has a population of 1,136,187 (Kenya National Bureau of Statistics (KNBS) 2019) people and covers an area of 30,570 square kilometers, of which 6,370 square kilometers is covered by Tsavo National Park (Magee et al. 2017). A large part of this County constitutes arid and semiarid land, and therefore over 50% of the population practice mixed farming and hence cultivate small pieces of land, and therefore the farming is heavily dependent on rainfall.

---

**Climate Change and its Impact in the Region**

Africa is considered to be one continent with the highest growth in population at 3% annually (IMF 2019). It is projected that by the year 2050, it will constitute about 25% of the world population (World Bank 2019). In addition, the mortality rate has reduced thereby straining available resources. Sustaining this growth has led to increase in social problems like rural to urban migration and lower yield in the

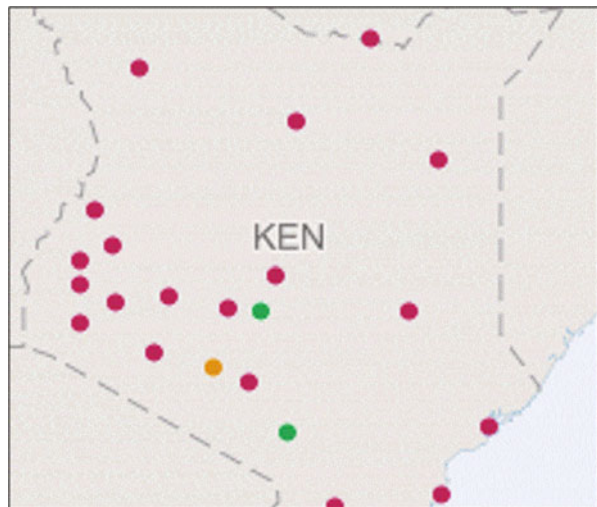
food basket among others. As a result the majority of the active working force has moved to cities and towns to look for alternative sources of income.

The smallholder farmers have not been influenced by the “Green Revolution” as they have continued with the practice of nonuse of chemical fertilizers, pesticides, and genetically modified organisms. These inherent practices are referred to as “traditional farming.” (Onwonga and Freyer 2006). In more recent years, farmers have become more reliant on extension officers. With the devolution of government services, extension officers have become few in some areas and highly concentrated in others (Franzel et al. 2014). These officers are expected to visit farmers to provide advisory services. It is usually tedious and time-consuming for both the farmer and the officer. There is thus need to investigate and keep record of weather conditions for better decision-making for small-scale famers who are the backbone of the economy in Kitui County (Magee et al. 2017). In addition assessment of cumulative health risk is a challenge in real-world situations because of limited data available for place and population-related pollution exposure (Solomon et al. 2016). With continued primary data collection, it is possible to create models that are more accurate in relation to this region.

The current weather stations within the country are a lot more concentrated in one half of the country and not so much on the other half. See map below (Fig. 1).

This study proposes to use a raspberry pi (RPi), a microcomputer quite popular now with IoT devices; it is of low-cost and easily adaptable to various conditions. The XBee is able to transmit information within short-range communication with very good accuracy and also low-power utilization and low-costs. The other parts of the paper will discuss methodology for the data collection, data transmission, storage, and visualization.

**Fig. 1** Weather stations in Kenya (Solomon et al. 2016)



## Other Studies

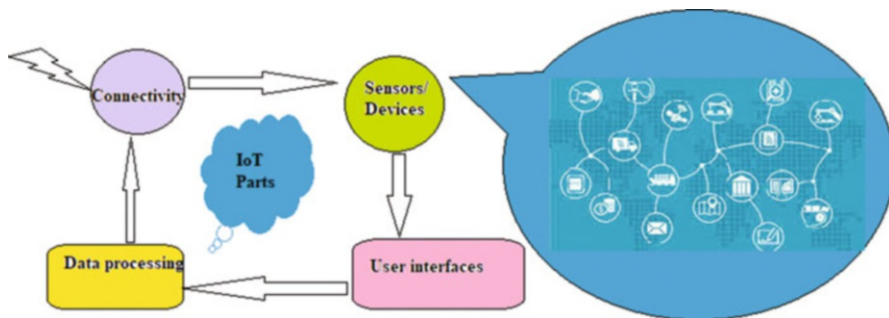
Studies have been done in agriculture and in pollution; however there is dearth in a studies combining pollution monitoring and agricultural parameters data collection. A review of previous studies has shown a gap in combination of these parameters which are of use to small-scale farming (Rehman et al. 2011) developed a WSN with sensor and actuator nodes to provide controlled water supply; this is very geared toward precision agriculture. In 2016 (Raja et al. 2016) used various types of sensors to monitor temperature and moisture values of the soil. The data was shared to a central station periodically and concentrated on soil data. A similar study was undertaken in 2015 by (C and S 2015). This study builds on work done by (Rehman et al. 2011) where remote monitoring was done for data collection and information shared with research facilities (Vatsal and Bhavin 2017). Worked on a system showing real-time temperature and relative humidity and once again only concentrated in agricultural information for display locally.

There are several systems designed for precision agriculture. They, however, mostly solve the problem of irrigation or temperature control. Those in environment solve data collection challenges, while those in agriculture solve a single or at most two challenges.

## Methodology

The Internet of Things (IoT) is described as connecting everyday objects via sensors and actuators to the Internet where the devices are intelligently linked together enabling new forms of communication between things and people and between things themselves. This technology has advanced rapidly in the last few years and has become quite popular in environment monitoring. The basic concept is illustrated in the figure below (Fig. 2).

IoT offers new and innovative ways to monitor and manage remote operations. “It allows having eyes and ears in remote places, constantly feeding applications and data stores with information. The low-cost of ‘things’ allows observing and

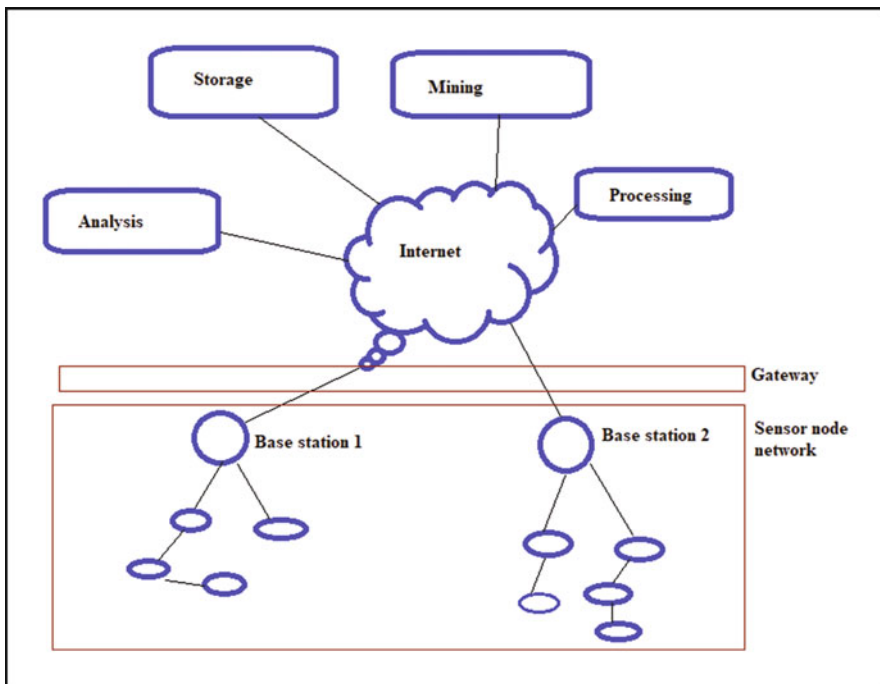


**Fig. 2** Basic parts of an IoT system

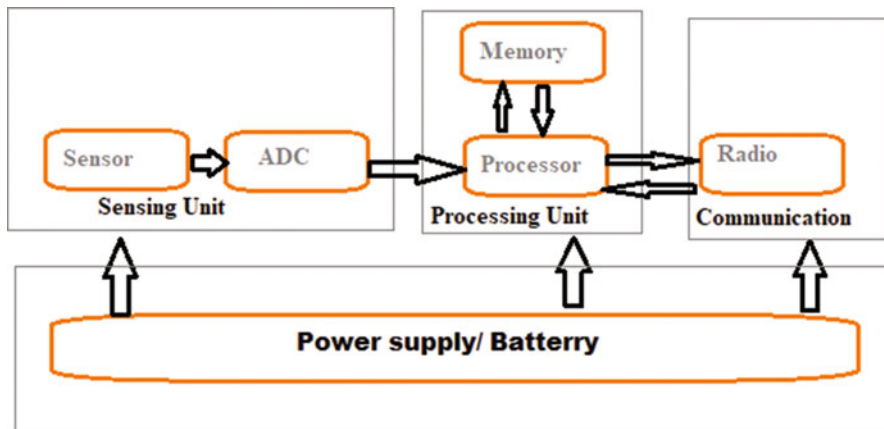
managing activities that were previously out of reach. With the Internet of Things, it is also possible to collect information about events that were once invisible, such as correlating weather patterns with industrial production” (“IoT in action – Towards Data Science” 2020). The advancement in wireless sensor networks is used in monitoring and controlling of various aspect in an agricultural field. In the same light, weather aspects for a station field. A wireless sensor network is composed of hardware and software. These are low-cost and low-power smart sensor nodes which monitor physical conditions. In our initial prototype test case, we monitored temperature, moisture, and pollution. These nodes can be spread across a large geographic area (Fig. 3).

A node: The main components of a sensor node are a microcontroller, transceiver, external memory, power source, and one or more sensors. The controller performs tasks, processes data, and controls the functionality of other components in the sensor node. The sensor node or mote can be deployed infield to form wireless sensor network for crop management and environment monitoring system (Fig. 4).

This study uses ZigBee, an IEEE 802.15.4 for the wireless sensor network of nodes. It is common in networking standard for personal area networks. The physical layer of ZigBee operates in the unlicensed industrial, scientific, and medical radio bands of 868 MHz, 915 MHz, and 2.4 GHz depending on the region. In this study, we adopt 2.4 GHz band because it is unlicensed in Kenya. The ZigBee protocol



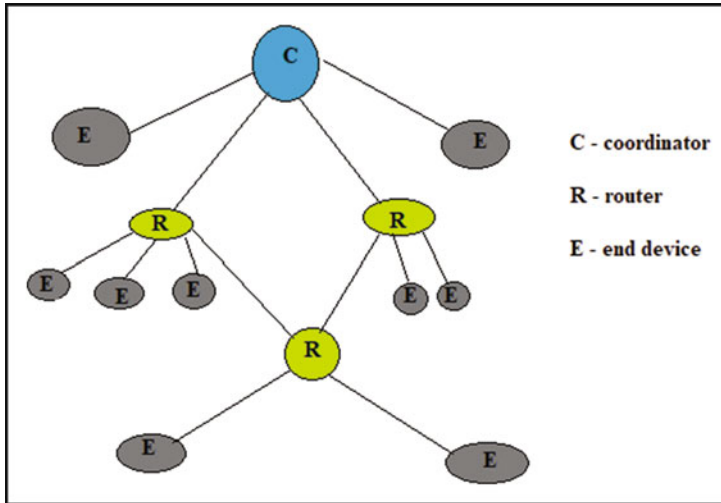
**Fig. 3** Node based IoT system with offsite processing



**Fig. 4** Block diagram of a node

mainly focuses on low-cost and low-power consumption. The low-power consumption characteristic is necessary since sensors are usually placed at a remote location where battery power supply is virtually the only option. In order to attain a low-power consumption characteristic, the ZigBee protocol operates at low data rates (250 kbps at 2.4 GHz); this imposes its limitation where high data transmission applications are required. From node to the servers, it is thus more realistic to use other applications, for instance, Wi-Fi (802.11) which offer high data rates. This is only done from the coordinator node. Depending on the situation and environment, the networks can take three forms of topologies: star, cluster tree, and mesh. Our study uses the mesh topology. A mesh network is accomplished by allowing devices in the cluster tree to topology communicate with each other using multiple routes. Consequently, the devices are able to send and receive messages reliably even when their preferred path is down or congested. This is the major advantage of a mesh network over star and cluster-tree networks. However, a mesh network has no guarantee of bandwidth since no synchronization is used which requires disabling of beacon mode (Fig. 5).

Mesh topology, also referred to as a peer-to-peer network, consists of one coordinator, several routers, and end devices. The following are the characteristics of a mesh topology: A mesh topology is a multi-hop network; packets pass through multiple hops to reach their destination. The range of a network can be increased by adding more devices to the network. It can eliminate dead zones. A mesh topology is self-healing, meaning during transmission, if a path fails, the node will find an alternate path to the destination. Devices can be close to each other so that they use less power. Adding or removing a device is easy. Any source device can communicate with any destination device in the network. Compared with star topology, mesh topology requires greater overhead. Mesh routing uses a more complex routing protocol than a star topology” (“2.3 ZigBee Topologies | Introduction to the ZigBee Wireless Sensor and Control Network | InformIT” n.d.).



**Fig. 5** Mesh-based network system

## System Design

This study proposes the combination of solving challenges in environment and in agriculture with a single system at the same time contributing to data enhancement for policy issues in both precision agriculture and pollution primary data.

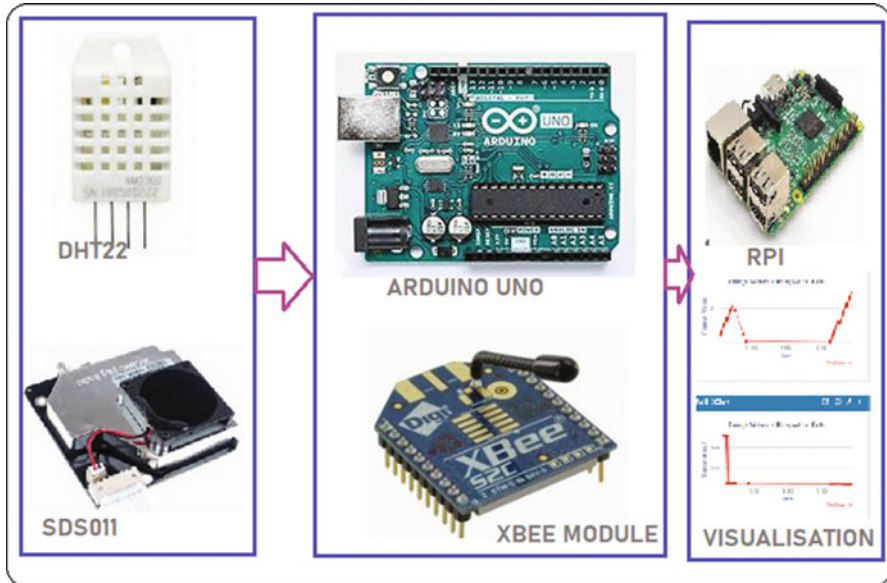
The building of pollution stations within the country present a problem of security and management. Having these stations placed at small farms and distributed keeps them safe. On the other hand, implementation of monitoring stations for local farmers is expensive and the communities lack the knowhow of management of the information collected. The cloud-based data management platform will provide this, while interested stakeholders (policy makers) will support the management of data. Kitui County is vast and most small farms lack connectivity to the main power grid. For the system to be self-sustaining in terms of power, the study uses solar photovoltaic and rechargeable batteries to power all electrical devices. The system incorporates a remote monitoring mechanism through a General Packet Radio Service modem to report soil temperature, soil moisture, WSN link performance, and photovoltaic power levels.

Having a system that encompasses data collection and data dissemination provides end to end solution for both small-scale farmers and policy makers.

The general workflow of the monitoring system consists of the following:

1. Taking temperature, humidity, and pollution data (PM 2.5 and PM 10) samples at predefined time intervals (Sensors)
2. Reading this data at a local level (Arduino Uno)
3. Sending data via a coordinator node (Raspberry Pi)
4. Visualizing data online





**Fig. 6** Detailed block diagram of our system

5. Going to sleep
6. Waking up and repeating the previous steps (Fig. 6)

Hardware needed for the end point of the system:

For the sensor node:

1. Raspberry pi 3B – this is a low-cost, credit-card sized computer that plugs into a computer monitor or TV and uses a standard keyboard and mouse. It is a capable little device that enables people of all ages to explore computing and to learn how to program in languages like Scratch and Python (Raspberrypi.org [n.d.](#))
2. Arduino UNO – Arduino is an open-source electronics platform based on easy-to-use hardware and software (Arduino.cc [n.d.](#))
3. Humidity and temperature sensor – DHT22 Sensor
4. Pollution sensor SDS011
5. Connectors – female-female, male-female, and male-male
6. Resistors

Software used in this project:

1. XCTU – This was used in this system to setup the XBee radios so that they can transmit data between each other.
2. NOOBS – This is the operating system needed to setup a RPi.
3. Python.
4. JSON.

5. Arduino IDE.
6. ThingSpeak is a free online platform that was used for data visualization

---

## System Implementation and Experiments

To set up and test this system, the XBee devices were first activated and set up using XCTU (a tool available online for free). They were all coded under the same network for ease of communication. The RPi was loaded with the necessary operating system (NOOBS) which comes with python – a coding language. In the project we also set up the Internet access for the raspberry pi as it acts as the gateway in this system.

On a laptop, we installed Arduino IDE (which is a development platform for Arduino boards) and also the sketches to run the two sensors for our prototype. JSON here is used as the shell to transfer data in a compact mode from the Arduino to the RPi.

On the RPi we run a program to call the data from the Arduino to the RPi and tested the same locally. Finally on ThingSpeak, we added the required APIs and run the visual data from our system.

The diagrams below further define our various steps (Figs. 7 and 8):

Once the codes were tested and found to be producing steady outputs, we put the sensors in a monitored environment – domestic fridge with proper calibration to test the humidity and temperature parameters and the results were displayed on the local Arduino software as 169% humidity and 12° Celsius continuously and repeatedly (Fig. 9).

```
#include<SoftwareSerial.h>
#include <SDS011.h>
#define Tx, Rx;
float p10,p25;
int error;

SDS011 my_sds;

void setup() {
  my_sds.begin(Tx,Rx);
  Serial.begin(9600);
}

void loop() {
  error = my_sds.read(&p25,&p10);
  if (! error) {
    Serial.println("P2.5: "+String(p25));
    Serial.println("P10: "+String(p10));
```

**Fig. 7** Figure 15 – clips of Initial codes for SDS sensor

```
#include <dht.h>

#define dht_apin A2 // Analog Pin sensor is connected to

dht DHT;
void setup(){

  Serial.begin(9600);
  delay(500); //Delay to let system boot
  Serial.println("DHT11 Humidity & temperature Sensor\n\n");
  delay(1000); //Wait before accessing Sensor

} //end "setup()"

void loop(){
  //Start of Program
  DHT.read11(dht_apin);
```

Fig. 8 Clips of Initial codes for DHT sensor

```
1 sensor_feb12m6
2 pin_setup()

3 loop(){
4 Start of Program
5   DHT.read11(dht_apin);

6   Serial.print("Current humidity = ");
7   Serial.print(DHT.humidity);
8   Serial.print("% ");
9   Serial.print("temperature = ");
10  Serial.print(DHT.temperature);
11  Serial.println("C ");

12  delay(10000); //Wait 10 seconds before accessing sensor again.

13  //Fastest should be once every two seconds.

14  end loop()
}
```

Current humidity = 169.00%	temperature = 12.00C
Current humidity = 169.00%	temperature = 12.00C
Current humidity = 169.00%	temperature = 12.00C
Current humidity = 169.00%	temperature = 12.00C
Current humidity = 169.00%	temperature = 12.00C
Current humidity = 169.00%	temperature = 12.00C

Fig. 9 Testing the DHT11 for both humidity and temperature in a controlled environment

We then transferred the tests to the natural environment and connected the router XBee connected to the raspberry pi. We were able to read the results from the temperature and humidity sensor as well.

We also run similar tests on the SDS011 – pollution sensor and obtained a consistent flow of results as below.

Once this was done, we then connected the end nodes to the router node for data aggregation. This was done using the python on the raspberry pi and wrapping the file using Json. We could then see our data collected using the IDs EN1, EN2, and EN3 from the three Arduino/XBee connected end nodes (Figs. 10, 11, 12, and 13).

```
1 port time
2 port json
3 port serial
4
5 r=serial.Serial("/dev/ttyUSB0", 9600)
6
7 if True:
8     if ser.in_waiting > 0 :
9         data=ser.readline()
10        j=data.decode('utf-8')
11        jo=json.loads(j)
12        print("Sensor Id= {}, Temperature = {} C, Humidity= {} %".format(jo['Id'], jo['sensor'][1]))
13
14
15
16
```

Shell

```
Sensor Id= EN3, Temperature = 26.4 C, Humidity= 58.1 %
Sensor Id= EN1, Temperature = 26.9 C, Humidity= 63.4 %
Sensor Id= EN2, Temperature = 27.4 C, Humidity= 60.5 %
Sensor Id= EN3, Temperature = 26.4 C, Humidity= 58.1 %
Sensor Id= EN1, Temperature = 26.9 C, Humidity= 63.4 %
Sensor Id= EN2, Temperature = 27.4 C, Humidity= 60.5 %
Traceback (most recent call last):
```

Fig. 10 Data accessed locally on RPi from three Arduino stations with DHT sensor only

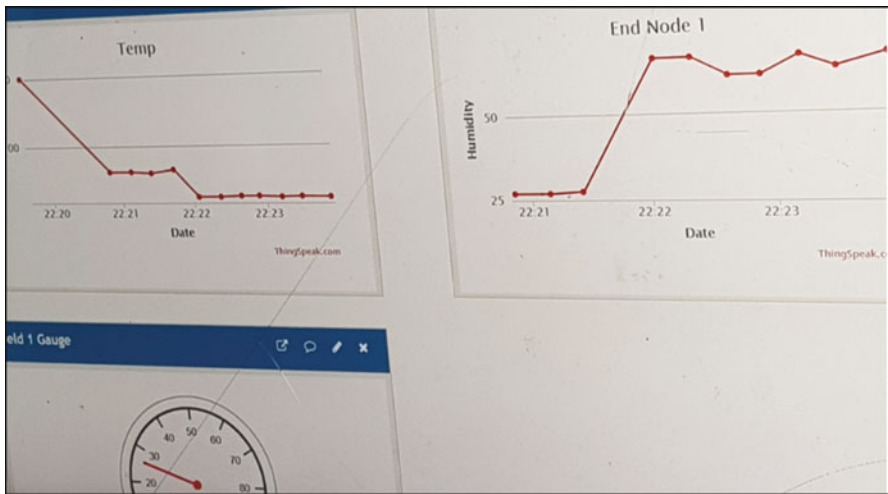


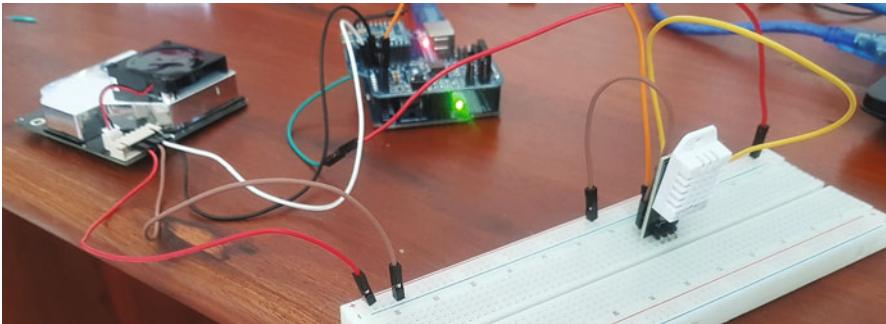
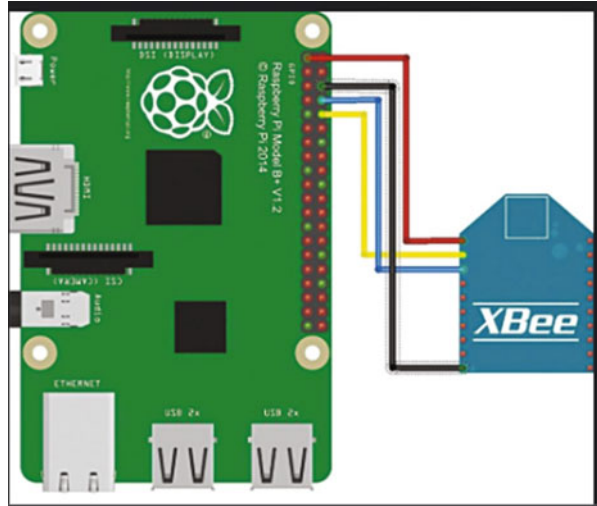
Fig. 11 Display on ThingSpeak of test data – screen shot taken during the testing of the prototype

## Conclusion

The phase of the entire project included:

1. Coming up with a design to collect data from sensors via a sensor node.
2. Sending the data to an online visualization platform via a control node and this step has been successful.

**Fig. 12** XBee connection to RPi (drawn using Fritzing software)



**Fig. 13** Sensor node using Arduino, XBee, DHT22, SDS011

Continuing work in this project involves adding a local database for localized data storage and adding a GSM module that allows ease of access of the online data remotely. The online platform and visualization will also be improved to be more robust with a private platform that can be more scalable in the future.

## References

- 2.3 ZigBee Topologies | Introduction to the ZigBee Wireless Sensor and Control Network | InformIT (n.d.) Retrieved January 15, 2020, from <http://www.informit.com/articles/article.aspx?p=1409785&seqNum=4>
- Arduino.cc (n.d.) Arduino – Introduction. Retrieved May 7, 2020, from <https://www.arduino.cc/en/guide/introduction>

- C, A, & S, A (2015) A study on developing a smart environment in agricultural irrigation technique. *Int J Ambient Syst Appl* 3(2/3):11–17. <https://doi.org/10.5121/ijasa.2015.3302>
- Franzel S, Sinja J, Simpson B (2014) Farmer-to-farmer extension in Kenya: the perspectives of organizations using the approach. ICRAF. <https://doi.org/10.5716/WP14380.PDF>
- IMF (2019) World economic outlook (October 2019). Retrieved January 21, 2020, from <https://www.imf.org/external/datamapper/datasets/WEO>
- IoT in action – Towards Data Science (2020) Retrieved January 15, 2020, from <https://towardsdatascience.com/iot-in-action-a8b7fac83619>
- Kenya National Bureau of Statistics (KNBS) (2019) 2019 Kenya population and housing census volume I: population by county and sub-county (Vol. I). Retrieved from <http://www.knbs.or.ke>
- Magee RV, Beerbower E, Bodhi B, Schindler S, Pfattheicher S, Reinhard M-A, ... Gorski PC (2017) KITUI county 2016 short rains food security assessment report. *ABA J* 102(4):24–25. <https://doi.org/10.1002/ejsp.2570>
- Onwonga R, Freyer B (2006) Impact of traditional farming practices on nutrient balances in smallholder farming systems of Nakuru District, Kenya. In Proceedings of the tropentag conference October, (October 2014), 11–13. Retrieved from [https://www.researchgate.net/publication/228372444\\_Impact\\_of\\_Traditional\\_Farming\\_Practices\\_on\\_Nutrient\\_Balances\\_in\\_Smallholder\\_Farming\\_Systems\\_of\\_Nakuru\\_District\\_Kenya/link/00b495156e425eb5ba00000/download](https://www.researchgate.net/publication/228372444_Impact_of_Traditional_Farming_Practices_on_Nutrient_Balances_in_Smallholder_Farming_Systems_of_Nakuru_District_Kenya/link/00b495156e425eb5ba00000/download) on January 19, 2020
- Raja R, Aruna P, Rajeshwaran N, Vignesh M, Vijayakumar M, Rajeshwaran N, ... Coimbatore T (2016) Automatic irrigation control using wireless sensor network 1299–1302
- Raspberrypi.org (n.d.) What is a raspberry pi? Retrieved May 7, 2020, from <https://www.raspberrypi.org/help/what-is-a-raspberry-pi/>
- Rehman A, Ali G, Shaikh NA, Shaikh ZA (2011) Efficient irrigation water management using cost effective wireless sensor and actuator networks. *Sarhad J Agric* 27(3):423–435
- Solomon G, Morello-Frosch R, Zeise L, Faust JB (2016) Cumulative environmental impacts: science and policy to protect communities. *Annu Rev Public Health*. <https://doi.org/10.1146/annurev-publhealth-032315-021807>
- Vatsal S, Bhavin M (2017) Using raspberry pi to sense temprature and relative humidity. *Int Res J Eng Technol (IRJET)* 4(2):380–385. Retrieved from <https://irjet.net/archives/V4/i2/IRJET-V4I276.pdf>
- World Bank (2019) World’s population will continue to grow and will reach nearly 10 billion by 2050. Retrieved January 21, 2020, from <http://blogs.worldbank.org/opendata/worlds-population-will-continue-grow-and-will-reach-nearly-10-billion-2050>

**Open Access** This chapter is licensed under the terms of the Creative Commons Attribution 4.0 International License (<http://creativecommons.org/licenses/by/4.0/>), which permits use, sharing, adaptation, distribution and reproduction in any medium or format, as long as you give appropriate credit to the original author(s) and the source, provide a link to the Creative Commons license and indicate if changes were made.

The images or other third party material in this chapter are included in the chapter’s Creative Commons license, unless indicated otherwise in a credit line to the material. If material is not included in the chapter’s Creative Commons license and your intended use is not permitted by statutory regulation or exceeds the permitted use, you will need to obtain permission directly from the copyright holder.



---

**Part III**

**Interdisciplinary Aspects of Climate Change**



# Climate Change Adaptation in Southern Africa: Universalistic Science or Indigenous Knowledge or Hybrid

# 86

Tafadzwa Mutambisi, Nelson Chanza, Abraham R. Matamanda, Roseline Ncube, and Innocent Chirisa

## Contents

Introduction .....	1752
Climate Change Response in Southern Africa .....	1754
Knowledge Driving Climate Change Responses in Southern Africa .....	1755
Vulnerability Concept .....	1757
Ecosystem-Based Adaptation Concept .....	1757
REDD+ Concept .....	1758
Resilience Concept .....	1759
Experiences with Climate Change Responses in Southern Africa .....	1760

This chapter was previously published non-open access with exclusive rights reserved by the Publisher. It has been changed retrospectively to open access under a CC BY 4.0 license and the copyright holder is “The Author(s)”. For further details, please see the license information at the end of the chapter.

T. Mutambisi

Department of Demography Settlement and Development, University of Zimbabwe, Harare, Zimbabwe

N. Chanza

Department of Geography, Bindura University of Science Education, Bindura, Zimbabwe

A. R. Matamanda

Department of Urban and Regional Planning, University of the Free State, Bloemfontein, South Africa

R. Ncube

Faculty of Gender and Women Studies, Women’s University in Africa, Harare, Zimbabwe

I. Chirisa (✉)

Department of Demography Settlement and Development, University of Zimbabwe, Harare, Zimbabwe

Department of Urban and Regional Planning, University of the Free State, Bloemfontein, South Africa

© The Author(s) 2021

W. Leal Filho et al. (eds.), *African Handbook of Climate Change Adaptation*,  
[https://doi.org/10.1007/978-3-030-45106-6\\_8](https://doi.org/10.1007/978-3-030-45106-6_8)

1751



---

Towards a Hybrid Knowledge Approach in Climate Change Adaptation .....	1761
Conclusions and Recommendations .....	1761
References .....	1762

---

## Abstract

The aims of this chapter are to seek answer, through a document review, case studies, and thematic content analysis, to which direction Southern Africa should take in the face of climate change and to suggest a framework for adaptations by communities experiencing climatic events. Acknowledging that the fundamental set of ideas provided by indigenous knowledge (IK) works best at a small scale, the chapter argues for the need to seriously value IK-based response practices in the knowledge hybridization agenda. The worsening vulnerability potentiated by the increasing magnitude and severity of climate change impacts is a reminder that local-based indigenous response practices in Africa need to be complemented. Adaptation to climate change calls for real and surreal measures all being applied in combination. Across Africa, these measures have, at times, included the preservation of forest resources which increased carbon sinking and enhanced community resilience against climate change. Universalistic and orthodox sciences have punctuated and amplified these efforts by speaking of such initiatives as mitigation and adaptation through programs, e.g., Reducing Emissions from Deforestation and Forest Degradation (REDD+) and ecosystem-based adaptation (EbA). The merits of the two approaches have resulted in increasing call among scholars for the merging of these programs with IK. However, it remains to be fully understood how such a hybrid approach could be operationalized without treating the latter as an inferior element in climate science discourses.

---

## Introduction

The complexity of climate change has attracted global attention and the various institutions worldwide to come up with adaptation and resilience methodologies and strategies (UNDP 2018). Throughout history, people and societies have successfully adjusted to and coped with climate change and extreme events. While climate change is a global issue, it is felt on a local scale (Silber 2013). This is because climate change affects many dimensions of development, including society, politics, science, economics, and moral and ethical questions (Henderson et al. 2017; Ogolla 2016). Local institutions are therefore at the frontline of adaptation as they attempt to factor in the local effects and how to mitigate these negative effects of climate change. This has resulted in the development of initiatives where climate change is factored into a variety of development plans on how to manage the increasingly extreme disasters and their associated risks, how to protect coastlines and deal with sea-level rise, how to best manage lands and forests, how to deal with and plan for reduced water availability, how to develop resilient crop varieties, and how to protect energy and public infrastructures (UNFCCC 2007; Carter et al. 2015; de Witt 2018).

Carbon dioxide, the heat-trapping greenhouse gas (GHG) that is the main contributor to global warming, has high longevity as it can remain in the atmosphere for hundreds of years (Dabasso et al. 2014). Even if the global community manages to establish strategies that can successfully reduce GHG emissions into the atmosphere, climate change and global warming will still be experienced and affect future generations. Thus, climate change continues to be a persistent global issue (Bauer and Scholz 2010). In Southern Africa, the effects of climate change have been experienced at a large scale as the region lacks adequate technology and proper management of its resources (Thinda et al. 2020). In addition, the combination of other various aspects of the region, such as its geographical exposure that has low levels of human development, weak institutions, high levels of inequality, and high dependence on agriculture, makes the African people vulnerable to the effects of climate change, especially those in the Southern African region as it is warming up at a faster rate than the global average (Kupika et al. 2019).

Climate change adaptation is a complex process that requires efforts from different stakeholders. The various problems that currently overwhelm Africa, for example, poor governance, lack of technology, and prevalence of poverty, make it difficult to establish the best approaches to achieve climate change adaptation. Basically, there are two available options that can be employed by the governments, namely, indigenous knowledge systems (IKS) and universalistic science. The former refers to the tested and proven knowledge that is used by local communities from their many years of observing and experiencing environmental phenomena, whereas the latter includes sophisticated techniques and approaches that are often associated with Western technologies and advanced way of mainstreaming climate change (Chirisa et al. 2018). These two approaches have their individual merits.

While some proponents view IKS as primitive and less reliable (e.g., Briggs 2005; Widdowson and Howard 2008), others assert that universalistic science is often too complicated and costly for African communities, which will result in their failure to maintain such a sophisticated technology (Wallner 2005; Simpson 2010; Walsh 2011). This causes ambiguity with regard to choosing the best approach to be employed to achieve climate change adaptation. In the same vein, this chapter proposes a hybrid method that considers the integration of both IKS and universalistic science. Thus, how Southern Africa can best adapt to climate change is investigated by weighing the strengths and limitations of the two knowledge systems in the context of climate change responses in the region. Through a document review, case studies, and thematic content analysis, the study determines the direction that Southern Africa should take in the face of climate change. The area of interest is shown in Fig. 1, which consists of Angola, Botswana, Eswatini, Lesotho, Malawi, Mozambique, Namibia, South Africa, Zambia, and Zimbabwe. It isolates specific themes to show how climate change responses have been pursued in the region. The chapter begins with a conceptual treatment of climate change adaptation in the frame of the distinctive knowledge forms (IKS and conventional knowledge systems) in the theory and practice of climate change responses. It then draws from existing scholars how these knowledge forms have characterized climate change mitigation and adaptation in Southern Africa. The discussion highlights the strengths



**Fig. 1** The case study, Southern African Region. (Source: Extracted from google.com/maps © Map data AfriGIS (Pty) Ltd)

and limitations of these knowledge systems and concludes that a hybrid system could be the best approach for driving an effective adaptation agenda in the region.

## Climate Change Response in Southern Africa

Although climate change will place additional stress on Southern Africa's resources, some authors argue that there is considerable adaptive potential (Karsenty et al. 2012; Wang and Corson 2015; Kupika et al. 2019). In order to promote a meaningful and sustainable development in the region, the probable impacts of global climate change need to be considered, as well as the best alternative that fits the regional context. In the science of climate change, the two approaches that guide climate change responses are mitigation and adaptation. Mitigation is concerned with stabilizing the levels of heat-trapping GHG and reducing its emissions into the atmosphere, whereas the focus of adaptation is on taking measures to respond to the observed or anticipated climate change impacts (Klein et al. 2005; IPCC 2014). Climate change has been the greatest threat to provision of infrastructure and facilities for human improvement in countries in the Global South. Thus, it calls for the need to develop mitigation and adaptation strategies that enhance the resilience of the region (Mugambiwa 2018; Kupika et al. 2019). The major goal in

mitigation is to avoid human interference in the climatic system and balances, whereas adaptation is a practice where human and natural systems devise appropriate measures in response to climate change impacts. In Southern Africa, most of the mechanisms developed by rural communities are complex and mainly based on culture and IK in the production of subsistence crops (Green 2008; Mugambiwa 2018). Mugambiwa (2018) stresses that Southern Africa's priority is to adapt to the climate change already being experienced anticipated in the region.

In the employment of the mitigation and adaptation approaches, it is critical to identify specific strategies, where IKS has been used, mainly in conjugation with universalistic science to strengthen the response system. The United Nations-based programs, Reducing Emissions from Deforestation and Forest Degradation (REDD +) and the ecosystem-based adaptation (EbA), are worth mentioning. These have been largely introduced through universal science that advocates for the reduction of GHG emissions into the atmosphere. Arguably, the knowledge of local and indigenous people has been found to be effective in the reduction of GHG emissions into the atmosphere (Kupika et al. 2019). Indigenous knowledge is already viewed as pivotal in several fields, such as sustainable development, agro-forestry, traditional medicine, biodiversity conservation, soil science, ethno-veterinary science, applied anthropology, and natural resource management (Mafongoya and Ajayi 2017). Many scholars highlight the significant role that IK plays in climate science and in facilitating climate change adaptation (Nyong et al. 2007; Green and Raygorodetsky 2010; Speranza et al. 2010; Crona et al. 2013; Ford et al. 2016; Chanza and Mafongoya 2017; Reyes-Garcia et al. 2019).

---

## Knowledge Driving Climate Change Responses in Southern Africa

The different forms of knowledge, used either individually or jointly, characterize the climate change responses in Southern Africa to achieve climate change adaptation. The definition of IK is very complex and distinguishes sciences from other knowledge traditions (Mugambiwa 2018). There is no universal knowledge to which science is privy and to which all other knowledge traditions must defer. Knowledge is produced with relevance to specific contexts and questions, including Newtonian physics and Palikur astronomy (Perez et al. 2007). Indigenous knowledge is known as local or traditional knowledge and is defined as the beliefs and intellectual behaviors of indigenous societies, or local information about the relationship between humans and their environment (Mafongoya and Ajayi 2017). This knowledge is accumulated, developed, and transmitted through local community experiences and know-how across generations. Therefore, one can argue that IK is based on the cultural beliefs of a community and that it is orally transferred from one generation to another (Casper 2007; Bryan et al. 2011; Baudron 2011). Thus, there exists a binary divide between universalistic science and IK (Appignanesi 2018). Western science is seen to be systematic, objective, open, and dependent on a detached center of rationality and intelligence. From a radical perspective, universalistic science is understood to represent modernity, whereas IK is perceived as a

traditional and backward way of life (Briggs 2005; Bauer and Scholz 2010). Clearly, these knowledge forms seem to be divergent and have been differently criticized. The cleavage between Western science and indigenous science is explored by Briggs (2005). Briggs (2005) argues that the use of IK is riddled with problems and challenges as it focuses on the (arte)factual, stating that this knowledge form has been romanticized. Wallner (2005) contends that Western science can become “very immoral” and “very dangerous” as it lacks subjectivity. From an African perspective, however, several scholars argue that IKS has been a sustainable factor in development of physical artefacts in space like infrastructure provisioning as it has minimized damage to the environment by allowing people to live in harmony with nature for generations (Kupika et al. 2019). Table 1 compares IK and universalistic science.

Local knowledge about ecosystems has been used in different parts of the world in an effort to respond to climate change. Universalism is defined as the epistemological and philosophical orientations taken by scientists of claims about the world or a particular issue in question (Green 2008). Western science is centralized and associated with the machinery of state, and its bearers believe in its superiority. The differences between IK and Western scientific knowledge are best described in the following grounds:

- Substantive grounds: there are differences in the subject matter between IK and Western knowledge.
- Methodological and epistemological grounds: the forms of knowledge employ different methods to investigate reality.
- Contextual grounds: IK is more deeply rooted in its environment (Mugambiwa 2018).

Therefore, it is undeniable that both Western science and IKS play significant roles in promoting sustainable development through mitigation and adaptation

**Table 1** Major differences between IK and universalistic science

Major differences	Western/formal science	IK
Mode of transmission	Written, formally documented	Oral, repetitive
Substantive differences	To construct general explanations; is removed from people's daily lives	Concerned with immediate and concrete necessities of people's daily livelihoods
Methodological and epistemological differences	It is open, systematic, objective, and analytical. It advances by building rigorously on prior achievements	It is closed, non-systematic, and holistic rather than analytical. It advances on the basis of new experiences, not on the basis of deductive logic
Contextual differences	It is divorced from epistemic framework in search for universal validity	It exists in a local context anchored to a particular social group, in a particular setting, at a particular time

Adopted from: Mafongoya and Ajayi (2017)

measures. The full conceptualization of IK can greatly contribute to the strengthening of the resilience of poor societies or marginal areas in Southern Africa. One of the best approaches to employ for climate change adaptation in poor regions is the ecosystem-based approach (Chanza and de Wit 2016; SSSI 2018; USAID 2018). In Zimbabwe, this is crucial especially to small-scale farmers as they are more prone to the effects of climate change. It is predicted that billions of people, particularly those in developing countries, face water and food shortage as well as greater risks to health and life as a result of climate change (Shava et al. 2009; Shames et al. 2012; Wang and Corson 2015). Thus, fully assessing the benefits of both science and IK in the face of climate change in Southern Africa is crucial. In an effort to adapt to climate change, there are conceptual issues that need to be considered. This chapter considers four factors that may possibly provide insights into the adaptation approach that may be employed in Southern Africa. The conceptual issues of vulnerability, EbA, REDD+, and resilience are discussed in the following sections.

---

## **Vulnerability Concept**

In relation to climate change, vulnerability is the degree to which a system is susceptible to, and unable to cope with, the adverse effects of climate change, including climate variability and extremes (UNFCCC 2007; IPCC 2014; Mavhura 2019). Climatic stress is already causing much pressure on the African region, making it highly vulnerable to the impacts of climate change (UNFCCC 2007; Bauer and Scholz 2010; Mugambiwa 2018). In Southern Africa, the poor predominantly depends on natural resource-based livelihoods, which are climate-sensitive. This makes them mostly vulnerable to poverty as they have minimum capacity to economically manage and cope with the damage caused by natural disasters or incremental degradation (Swinkels et al. 2019). Africa is well known to have diverse climates that are considered to be the most variable in the world on seasonal and decadal time scales. This makes the region's societies and ecosystems most prone to climatic events largely in the form of frequent floods and droughts (UNDP 2018). Africa's vulnerability to climate change also opens up room for its exposure to famine and widespread disruption of socioeconomic well-being as well as climate-sensitive diseases, such as diarrhea, malaria, and tuberculosis.

---

## **Ecosystem-Based Adaptation Concept**

Adaptation to climate change is associated with adjusting to expected or actual climate. The goal of adaptation is to reduce the vulnerability of the environment, regions, or societies to the harmful and dire effects of climate change (Green 2008). It also involves making the most of any potential beneficial opportunities associated with climate change. Ecosystem-based adaptation therefore refers to the management of ecosystems to enhance ecological structures and functions essential for ecosystems and the people to adapt to multiple changes, including climate change

(Kupika et al. 2019). This approach has the potential to contribute multiple benefits through the reduction of vulnerability to climate change as well as contribute to socioeconomic development and conservation (Mafongoya and Ajayi 2017). Ecosystem-based approaches include the maintenance of safety nets as a mechanism that best serves as a coping strategy during scarcity periods to enhance livelihood security. Some approaches implored under EbA include the following:

- Restoration of ecosystems that can reduce the exposure of human settlements to extreme weather events or climate change, e.g., combining the “building with nature” techniques with hard-engineering infrastructure to restore mangrove coastlines that reduce the risks of flood, erosion, and saline intrusion and support adaptation to sea-level rise (Bauer and Scholz 2010).
- Integration of sustainable ecosystem management practices into broad landscape-level planning processes. For example, integrated watershed management in peri-urban areas, which has proven to enhance water regulation to support the supply of water for drinking and hydroelectricity generation in cities.
- Payment for ecosystem services to diversify income generation and build adaptive capacity, for example, conserving a shoreline mangrove and coral reef system to maintain economies based on ecotourism, recreational activities, and fisheries.
- Climate mitigation by maintaining or enhancing carbon stocks with safeguards in place to support adaptation, for example, collective management of forested landscapes that promotes social learning to conserve forest function and structure, biodiversity and habitat connectivity, and climate-smart agriculture with agro-forestry systems.

At the center of this approach lies the recognition of nonlinear feedbacks between social and ecological processes. Ecosystem-based approaches can be applied to all types of ecosystems and at different scales from local to global (NASA’s Global Climate Change n.d.). Chanza and de Wit (2016) suggest that EbA should be best articulated at the local level where it can promote adaptation governance through IK. They also argue that the concept provides multiple benefits to society and the environment as it contributes to reducing vulnerability and increasing resilience to both climate and non-climate risks. Many cases in Africa have also shown that EbA approaches involving local people using their IKS can promote climate proofing and emission reduction (Hachileka 2010; Lo 2016; van Niekerk et al. 2017).

---

## **REDD+ Concept**

The UN-based REDD+ program is an incentive-based tool that bases its work on public and private agents’ self-interest in conservation strategies and the fact that they are well capable of calculating the opportunities as well as the costs associated with the reduction of GHG emissions into the atmosphere (Karsenty et al. 2012). The main concept of REDD+ is to make performance-based payments, which means that forest users and owners are paid to reduce GHGs emitted into the atmosphere

(Angelsen 2009). Payments for environmental services gives the forest owners the opportunity to receive incentives to motivate them to manage forests better and also minimize the rate at which deforestation occurs (Baudron 2011). Therefore, the concept of REDD+ is a rewarding mechanism to actors involved in keeping and restoring forests as well as a mechanism with the main objective of reducing carbon emissions (Karsenty et al. 2012; Skutsch and Ba 2010).

The concept of REDD+ has been implemented at a global level through the United Nations Development Program (UNDP) as a strategy to reduce GHG emissions into the atmosphere while promoting economic development, especially in developing regions, such as Africa (UNDP 2018). Developing countries have a competitive advantage in the carbon market if they choose to conserve their forests rather than convert them for agricultural use (Gantscho and Karani 2007). The REDD+ mechanism thus invests in providing incentives to projects that promote forest conservation and conversion, afforestation, and reforestation (Wang and Corson 2015; Leach and Scoones 2013; Shames et al. 2012). This has led to the introduction of carbon markets that have successfully paved way for developing countries to earn funds through forest conservation. The plus sign on REDD+ indicates how the concept is also dedicated to the enhancement of forest carbon stock which can also be referred to as forest rehabilitation and regeneration, carbon removal, negative emissions, negative degradation, or carbon uptake (Angelsen 2009). Chanza and de Wit (2016) reveal opportunities for the success of this initiative if local communities can use their IKS in forest conservation. In Kenya and Tanzania, for example, the success of REDD+ projects has been attributed to participatory planning where the knowledge of local citizens in technical analysis has helped in addressing the drivers of deforestation and forest degradation (Richards and Swan 2014).

---

## Resilience Concept

There is no universally accepted definition of resilience. The vast and growing literature available on urban resilience demonstrates the complexity of the concept as a target, as well as the challenges of mainstreaming recommendations into the urban development practice (UN-HABITAT 2017). The concept of resilience originated from ecological studies, exploring the varied ability of ecosystems to absorb and adapt to external pressures (Dau Kuir-Ayius 2016). The Intergovernmental Panel on Climate Change (IPCC) (2014, p. 1772) defines it as “the capacity of social, economic, and environmental systems to cope with a hazardous event or trend or disturbance, responding or reorganising in ways that maintain their essential function, identity, and structure, while also maintaining the capacity for adaptation, learning, and transformation.” Understanding that human systems function as complex, interdependent, and integrated social-ecological systems is crucial to understanding how resilience-based planning, development, and management can protect life and assets as well as maintain the continuity of functions through any plausible shock or stress (Sekar et al. 2019; UN-HABITAT 2017; Dau Kuir-Ayius 2016). Thus, the Southern African region needs to develop resilient strategies that will assist



them in coping with climate change (Doyon 2016; Dau Kuir-Ayius 2016; UN-HABITAT 2017; Kupika et al. 2019). Scholarship treating IK and climate change resilience is still developing (Bohensky and Maru 2011; DeAngelis 2013; Makate 2020). Despite the phenomenal growth in resilience literature, Bohensky and Maru (2011) express the lack of clarity and empirical evidence for the relationship between IK and resilience. Citing the utility of IK in agricultural projects, Makate (2020) argues that in establishing resilience to climate change, local communities should be seen as equal partners in the development process. The next section discusses the strengths and limitations of the existing climate change response practices in Southern African countries.

---

## Experiences with Climate Change Responses in Southern Africa

The study found out that in its trajectory to curb the effects of climate change, Southern Africa is largely driven by modernity. However, due to the slower development of this region compared with the Western and European regions, it is difficult to implement technologically advanced measures owing to its limited manpower, poor resource management, and inadequate finances to make use of the science. Therefore, traditional knowledge and IK play a significant role in climate change adaptation in many rural communities (Green 2008; Mafongoya and Ajayi 2017; Kupika et al. 2019). However, due to modernity, it is now rare to find pure IKS practices that are not contaminated with the conventional construct of adaptation practices. Thus, it is important to fully understand indigenous-based practices that continue to shape the adaptation landscape in the African context and to assess the strengths and limitations of such strategies. This chapter argues that one way to complement the strengths of adaptation practices in the region is to complement the two forms of knowledge. Conscious of the blending gaps that have been highlighted in adaptation literature, the next sections also propose how the two knowledge systems can jointly work best.

In Southern Africa, there exists a diverse and unique group of cultures, including the Shona, Ndebele, Zulu, Tswana, Xhosa, Pedi, Tshangni, Venda, and Suthu, among many others (Mabogunje n.d.; Hanyani-Mlambo 2002). The main common aspect of all these African cultures is that they all started as hunters, gatherers, nomads, and pastoralists. Their traditions and way of living are still being practiced today, especially in marginal areas, for instance, in the Mbire District in Zimbabwe and the Khoisan in the Kalahari Desert of Botswana (Dube et al. 2014). In this regard, it can be safe to agree that traditional knowledge is also an ecological knowledge. It involves adaptation processes that have been handed down from generation to generation, and thus, they are useful in climate change adaptation (Dabasso et al. 2014).

The renewal of IK throughout generations has ensured the well-being of many Southern African people through ensuring food security, early warning systems, environmental conservation, and disaster risk management (Mawere 2010). Therefore, it can be deduced that the people rely on this traditional knowledge for social capital and food production as a way to ensure survival. The advent of universalistic science that has enabled the invention of technologies, machines, and concepts that

are mostly unsustainable has led to IK being disregarded as it is considered as backward and old (Carmody 1998; Mugambiwa 2018).

---

## **Towards a Hybrid Knowledge Approach in Climate Change Adaptation**

Climate change adaptation calls for more than just local experiences or scientific knowledge. Effective adaptation to climate change in Southern Africa requires the best knowledge regardless of where it is coming from (Shava et al. 2009). Hybrid knowledge from both sources is only possible through collaborative process, community participation, and involvement and interactions between the locals and scientists. It is also important to acknowledge that IK can provide solutions to food insecurity and poverty (Hussein and Suttie 2016). Appropriate and effective use of IK can promote a number of advantages that can match those of conventional science. These include environmental conservation and management of disasters in terms of prevention, mitigation, recovery, prediction or early warning, preparedness, and healing through traditional medicinal practices by producing traditional foods. In Kenya, the Maasai traders have relied on the benefits provided by the earth's resource, which has ensured a stable livelihood for centuries (Wang and Corson 2015).

As the world warms, traditional weather indicators may become less and less valuable. Individual species will adapt to the impacts of local climate change in idiosyncratic and unpredictable ways. Animals may change their behaviors or their ranges, whereas plants may begin flowering at different times. It is feared that these changes might render traditional knowledge less reliable. One way to strengthen the hybridization of IK and universalistic science in terms of climate change response is to revitalize or strengthen local institutions (Mararike 2011; Makate 2020). According to Makate (2020), the integration approach can work best only where climate adaptation practitioners build from existing local-based knowledge forms, rather than moving to replace them. When strengthened, local institutions can enhance the employment and scaling success of climate adaptation projects and innovations. Such efforts will improve information sharing, resource mobilization, stakeholder coordination, network establishment, and capacity building with local citizens as well as provide leadership and control of climate adaptation programs. The technological orientation of adaptation practice as seen through irrigation infrastructure in the agricultural sector, for instance, can be enhanced if local farmers are given sovereign rights over the traditional crop or animal varieties of their choice. Accordingly, it is reasonable to suggest that using the two knowledge forms individually will not provide solutions to the increasing threats of climate change in Southern Africa.

---

## **Conclusions and Recommendations**

Given the sensitivity of the entire socioeconomic sectors and natural systems to the increasing climatic events, the Southern African region is expected to devise appropriate mitigation and adaptation practices. The region faces a quandary in terms of

the trajectory that it should take in its development plan in the context of the existing and anticipated climate change threats. Climate change is starting to be factored into a variety of development plans on how to manage the increasingly extreme disasters faced by humanity and their associated risks, how to protect coastlines and deal with sea level rise, how to best manage land and forests, how to deal with and plan for reduced water availability, how to develop resilient crop varieties, and how to protect energy and public infrastructure. In other parts of the world, countries are working on building flood defenses, plan for heat waves and high temperatures, install water-permeable pavements to better deal with floods and stormwater, and improve water storage and use. However, in the absence of national or international climate policy direction, cities and local communities worldwide have focused on solving their own problems on climate change. The importance that communities in Southern Africa place on IKS in the face of climate change deserves recognition. However, due to changing seasons, IKS needs to be integrated with scientific methods as it cannot address the magnitude of the challenge alone. In the face of global climate change and its emerging challenges, unknowns, and uncertainties, it is important to base the decision-making for policies and actions on the best available knowledge. The multisectoral and cross-scale nature of climate change responses, such as REDD+ and ecosystem-based adaptation approaches, requires the integration of a range of disciplines, actors, and institutions interacting at different levels and influencing diverse decision networks.

---

## References

- Angelsen A (ed) (2009) Realising REDD+ National strategy and policy options. CIFOR, Bogor. Available online: <http://www.cifor.cgiar.org>
- Appignanesi L (2018) Blurred binary code for the sustainable development of functional systems: blurred binary code. *Syst Res Behav Sci* 35(4):386–398. <https://doi.org/10.1002/sres.2537>
- Baudron F (2011) Agricultural intensification – saving space for wildlife? PHD thesis, Wageningen University
- Bauer S, Scholz I (2010) Adaptation to climate change in Southern Africa: new boundaries for sustainable development? *Clim Dev* 2(2):83–93. <https://doi.org/10.3763/cdev.2010.0040>
- Bohensky EL, Maru Y (2011) Indigenous knowledge, science, and resilience: what have we learned from a decade of international literature on “integration”? *Ecol Soc* 16(4):6. <https://doi.org/10.5751/ES-04342-160406>
- Briggs J (2005) The use of indigenous knowledge in development: problems and challenges. *Progr Dev Stud* 5(2):99–114
- Briggs J, Moyo B (2012) The resilience of indigenous knowledge in small-scale African agriculture: key drivers. *Scottish Geogr J* 128(1):64–80. <https://doi.org/10.1080/14702541.2012.694703>
- Bryan E, Akpalu W, Yesuf M et al (2011) Global Carbon Markets Opportunities for Sub Saharan Africa in Agriculture and Forestry. *Clim Dev* 2(4):309–330. <https://doi.org/10.3763/cdev.2010.0057>
- Caputo S (n.d.) Urban resilience: a theoretical and empirical investigation, p 181
- Carmody P (1998) Neoclassical practice and the collapse of industry in Zimbabwe: the cases of textiles, clothing, and footwear. *Econ Geogr* 74(4):319. <https://doi.org/10.2307/144328>
- Carter JG, Cavan G, Connelly A, Guy S, Handley J, Kazmierczak A (2015) Climate change and the city: building capacity for urban adaptation. *Progr Plann* 95:1–66
- Casper JK (2007) Agriculture: the food we grow and animals we raise. Chelsea House, New York

- Chanza N, de Wit A (2016) Enhancing climate governance through indigenous knowledge: case in sustainability science. *S Afr J Sci* 112(3/4). <https://doi.org/10.17159/sajs.2016/20140286>
- Chanza N, Mafongoya PL (2017) Indigenous-based climate science from the Zimbabwean experience: from impact identification, mitigation and adaptation. In: Mafongoya PL, Ajayi OC (eds) *Indigenous knowledge systems and climate change management in Africa*. Technical Centre for Agricultural and Rural Cooperation (CTA), Wageningen, 316pp
- Chirisa I, Matamanda A, Mutambwa J (2018) Africa's dilemmas in climate change communication: universalistic science versus indigenous technical knowledge. In: Leal Filho W, Manolas E, Azul A, Azeiteiro U, McGhie H (eds) *Handbook of climate change communication: vol. 1. Climate change management*. Springer, Cham
- Crona B, Wutich A, Slade A, Gartin M (2013) Perceptions of climate change: linking local and global perceptions through a cultural knowledge approach. *Clim Change* 119(2):519–531. <https://doi.org/10.1007/s10584-013-0708-5>
- Dabasso BH, Taddese Z, Hoag D (2014) Carbon stocks in semi-arid pastoral ecosystems of northern Kenya. *Pastoralism* 4(1):5
- Dau Kuir-Ayius D (2016) Building community resilience in mine impacted communities: a study on delivery of health services in Papua new guinea. Massey University. Available online: [https://mro.massey.ac.nz/bitstream/handle/10179/9882/02\\_whole.pdf?sequence=2&isAllowed=y](https://mro.massey.ac.nz/bitstream/handle/10179/9882/02_whole.pdf?sequence=2&isAllowed=y). Accessed 3 Nov 2019
- De la Vega I, Puente JM, Sanchez M (2019) The collapse of Venezuela vs. the sustainable development of selected South American Countries. MDPI
- de Witt S (2018) Measuring our investment in the future. *Afr Eval J* 6(2):a343. <https://doi.org/10.4102/aej.v6i2.343>
- DeAngelis K (2013) Building resilience to climate change through indigenous knowledge: the case of Bolivia. Climate and Development Knowledge Network (CDKN). Available online: [https://cdkn.org/wp-content/uploads/2013/03/Bolivia\\_InsideStory.pdf](https://cdkn.org/wp-content/uploads/2013/03/Bolivia_InsideStory.pdf). Accessed 30 June 2010
- Doyon A (2016) An investigation into planning for urban resilience through niche interventions. Doctoral, The University of Melbourne
- Dube F, Nhapi I, Murwira A, et al (2014) Potential of weight of evidence modelling for gully erosion hazard assessment in Mbire District – Zimbabwe, pp 1–31
- Ford JD, Cameron L, Rubis J, Mailliet M, Nakashima D, Willox AC, Pearce T (2016) Including indigenous knowledge and experience in IPCC assessment reports. *Nat Clim Change* 6:349–353
- Gantsho M, Karani P (2007) Entrepreneurship and innovation in development finance institutions for promoting the clean development mechanism in Africa. *Dev South Afr* 24(2):335–344
- Green LJ (2008) 'Indigenous knowledge' and 'science': reframing the debate on knowledge diversity. *Archaeologies* 4(1):144–163
- Green D, Raygorodetsky G (2010) Indigenous knowledge of a changing climate. *Clim Change* 100:239–242
- Gujba H, Thorne S, Mulugetta Y, Rai K, Sokona Y (2012) Financing low carbon energy access in Africa. *Energy Policy* 47:71–78
- Hachileka E (2010) Climate change adaptation strategies in the Chiawa community of the lower Zambezi game management area, Zambia. In: Andrade PA, Herrera FB, Cazzolla GR (eds) *Building resilience to climate change: ecosystem-based adaptation and lessons from the field*. IUCN, Gland, pp 89–98
- Hanyani-Mlambo BT (2002) Strengthening the pluralistic agricultural extension system: a Zimbabwean case study. Food and Agriculture Organization of the United Nations (FAO), Rome
- Henderson JV, Storeygard A, Deichmann U (2017) Has climate change driven urbanization in Africa? *J Dev Econ* 124:60–82
- Hussein K, Suttie D (2016) Rural-urban linkages and food systems in sub-Saharan Africa: the rural dimension, vol 5. IFAD, Rome
- IPCC (2014) Climate change 2014: impacts, adaptation, and vulnerability. Part B: regional aspects. In: Barros VR, Field CB, Dokken DJ, Mastrandrea MD, Mach KJ, Bilir TE, Chatterjee M, Ebi KL, Estrada YO, Genova RC, Girma B, Kissel ES, Levy AN, MacCracken S, Mastrandrea PR, White LL (eds) *Contribution of working group II to the fifth assessment report of the Intergovernmental Panel on Climate Change*. Cambridge University Press, Cambridge, UK/New York, p 688

- Islam N, Winkel J (2017) Climate change and social inequality. DESA working paper no 152 ST/ESA/2017/DWP/152. Department of Economic & Social Affairs. Available online [https://www.un.org/esa/desa/papers/2017/wp152\\_2017.pdf](https://www.un.org/esa/desa/papers/2017/wp152_2017.pdf). Accessed 5 Mar 2020
- Kahn ME, Walsh R (2014) Cities and the environment. National Bureau of Economic Research working paper 20503, vol 100, Cambridge, Massachusetts, United States
- Karsenty A, Vogue A, Castell F (2012) “Carbon rights”, REDD+ and payments for environmental services. Available online: <https://doi.org/10.1016/j.envsci.2012.08.013>
- Klein RJ, Schipper ELF, Dessai S (2005) Integrating mitigation and adaptation into climate and development policy: three research questions. *Environmental science & policy* 8(6):579–588
- Kupika OL, Gandiwa E, Godwell N, et al (2019) Local ecological knowledge on climate change and ecosystem-based adaptation strategies promote resilience in the middle Zambezi biosphere reserve, Zimbabwe, p 15
- Leach M, Scoones I (2013) Carbon forestry in West Africa: the politics of models, measures and verification processes. *Inst Dev Stud* 23(5):957–967
- Lo V (2016) Synthesis report on experiences with ecosystem-based approaches to climate change adaptation and disaster risk reduction. Technical series no 85. Secretariat of the Convention on Biological Diversity, Montreal, 106 p
- Mabogunje AL (n.d.) Urban planning and the post-colonial state in Africa: a research overview. Available online: <https://www.jstor.org/stable/pdf/524471.pdf?refreqid=excelsior%3Aacebfc2f9b1cef3793196abe2ba7234cd>. Accessed 11 Feb 2020
- Mafongoya PL, Ajayi OC (eds) (2017) Indigenous knowledge systems and climate change management in Africa. CTA, Wageningen
- Makate C (2020) Local institutions and indigenous knowledge in adoption and scaling of climate-smart agricultural innovations among sub-Saharan smallholder farmers. *Int J Clim Change Strat Manag* 12(2):270–287
- Mararike CG (2011) Survival strategies in rural Zimbabwe: the role of asset, indigenous knowledge and organisation. Best Practices Books, Harare
- Mavhura E (2019) Systems analysis of vulnerability to hydrometeorological threats: an exploratory study of vulnerability drivers in Northern Zimbabwe. Springer. Available online: <https://doi.org/10.1007/s13753-019-0217-x>
- Mawere M (2010) Indigenous knowledge systems’ (IKSs) potential for establishing a moral, virtuous society: lessons from selected IKSs in Zimbabwe and Mozambique. *J Sustain Dev Afr* 12(7):209–221
- Moutinho P, Schwartzman S (eds) (2005) Tropical deforestation and climate change. Brasilia: Instituto de Pesquisa Ambiental da Amazônia and Environmental Defense
- Mugambiwa SS (2018) Adaptation measures to sustain indigenous practices and the use of indigenous knowledge systems to adapt to climate change in Mutoko rural district of Zimbabwe. *Jambá J Disaster Risk Stud* 10(1):1–9
- NGCC (n.d.) Climate change adaptation and mitigation. Available online <https://climate.nasa.gov/solutions/adaptation-mitigation>. Accessed 5 Mar 2020
- Nyong A, Adesina F, Elasha BO (2007) The value of indigenous knowledge in climate change mitigation and adaptation strategies in the African Sahel. *Mitigat Adapt Strat Global Change* 12:787–797
- Ogolla PA (2016) Africa and the plight of climate change. *Development* 2016(59):373–376
- P Perez, C., Roncoli, C., Neely, C., & Steiner, J. L. (2007). Can carbon sequestration markets benefit low-income producers in semi-arid Africa? Potentials and challenges. *Agric Syst*, 94(1), 2–12. Read “Advancing the Science of Climate Change” at NAP.edu (n.d.). <https://doi.org/10.17226/12782>.
- Reyes-García V, García-del-Amo D, Benyei P, Fernández-Llamazares A, Gravani K, Junqueira AB, Labeyrie V, Li X, Matias DMS, McAlvay A, Mortyn PG, Porcuna-Ferrer A, Schlingmann A, Soleymani-Fard R (2019) A collaborative approach to bring insights from local observations of climate change impacts into global climate change research. *Curr Opin Environ Sustain* 39:1–8. <https://doi.org/10.1016/j.cosust.2019.04.007>

- Richards M, Swan SR (2014) Participatory subnational planning for REDD+ and other land use programmes: methodology and step-by-step guidance. SNV Netherlands Development Organisation, REDD+ Programme, Ho Chi Minh
- SDG Lead (2018) Final evaluation of the “REDD+ Governance and Finance Integrity for Africa” programme
- Sekar S, Lundin K, Tucker C, et al (2019) Building resilience a green growth framework for mobilizing mining investment. World Bank Publications, Washington, DC. Available online: <http://documents.worldbank.org/curated/en/689241556650241927/pdf/Building-Resilience-A-Green-Growth-Framework-for-Mobilizing-Mining-Investment.pdf>. Downloaded 6 Nov 2019
- Shames S, Wollenberg E, Buck LE, et al (2012) Institutional innovations in African smallholder carbon projects. CGIAR Research Program on Climate Change, Agriculture and Food Security (CCAFS) 8. CCAFs, Copenhagen. Available online <http://www.ccafs.cgiar.org>
- Shava S, O'Donoghue R, Krasny ME, Zazu C (2009) Traditional food crops as a source of community resilience in Zimbabwe. *Int J Afr Renaissance Stud* 4(1):31–48
- Silber T (2013) Kariba REDD+ project monitoring report 2011–2012. South Pole Carbon, Zurich
- Simpson MC (2010) Quantification and Magnitude of Losses and Damages Resulting from the Impacts of Climate Change: Modelling the Transformational Impacts and Costs of Sea Level Rise in the Caribbean (Key Points and Summary for Policy Makers Document). New York: United Nations Development Programme (UNDP)
- Skutsch MM, Ba L (2010) Crediting carbon in dry forests: the potential for community forest management in West Africa. *Forest Policy Econ* 12(4):264–270
- Speranza CI, Kiteme B, Ambenje P, Wiesmann U, Makali S (2010) Indigenous knowledge related to climate variability and change: insights from droughts in semi-arid areas of former Makueni District, Kenya. *Clim Change* 100:295–315
- SSSI (2018) A rising Africa in a fragile environment the imitative on sustainability, stability and security. Sustainability, Stability and Security Initiative (SSSI). Available online <http://www.3S-Initiative.org>
- Swinkels R, Norman T, Blankespoor B et al (2019) Analysis of spatial patterns of settlement, internal migration, and welfare inequality in Zimbabwe. World Bank Group, Washington, DC
- Thinda KT, Ogundeji AA, Belle JA, Ojo TO (2020) Determinants of relevant constraints inhibiting farmers' adoption of climate change adaptation strategies in South Africa. *J Asian Afr Stud* 56(1):1–18
- UNDP (2017) Climate change and human development: towards building a climate resilient nation. UNDP, New York
- UNDP (2018) Strengthening biodiversity and ecosystems management and climate-smart landscapes in the mid to lower Zambezi Region of Zimbabwe, New York
- UNFCCC (2007) Climate change: impacts, vulnerabilities and adaptation in developing countries. United Nations Framework Convention on Climate Change, Bonn. Available online: <https://unfccc.int/resource/docs/publications/impacts.pdf>. Downloaded 6 Mar 2020
- UN-HABITAT (2017) Trends in urban resilience. United Nations Human Settlements Programme (UN-Habitat), Nairobi. Available online: [http://urbanresiliencehub.org/wp-content/uploads/2017/11/Trends\\_in\\_Urban\\_Resilience\\_2017.pdf](http://urbanresiliencehub.org/wp-content/uploads/2017/11/Trends_in_Urban_Resilience_2017.pdf). Downloaded 6 Nov 2019
- USAID (2018) The intersection of global fragility and climate risks. USAID, Washington, DC
- van Niekerk A, Scinocca JF, Shepherd TG (2017) The modulation of stationary waves, and their response to climate change, by parameterized orographic drag. *Journal of the Atmospheric Sciences* 74(8):2557–2574
- Wallner F (2005) Indigenous knowledge and Western science: contradiction or cooperation. *Indilinga Afr J Indig Knowl Syst* 4(1):46–54
- Walsh D (2011) Moving beyond Widdowson and Howard: traditional knowledge as an approach to knowledge. *Int J Crit Indig Stud* 4(1):2–11
- Wang Y, Corson C (2015) The making of a ‘charismatic’ carbon credit: clean cookstoves and ‘uncooperative’ women in Western Kenya. 47:2064–2079. <https://doi.org/10.1068/a130233p>
- Widdowson F, Howard A (2008) Disrobing the aboriginal industry: the deception behind indigenous cultural preservation. McGill-Queen's University Press, Montreal

**Open Access** This chapter is licensed under the terms of the Creative Commons Attribution 4.0 International License (<http://creativecommons.org/licenses/by/4.0/>), which permits use, sharing, adaptation, distribution and reproduction in any medium or format, as long as you give appropriate credit to the original author(s) and the source, provide a link to the Creative Commons license and indicate if changes were made.

The images or other third party material in this chapter are included in the chapter's Creative Commons license, unless indicated otherwise in a credit line to the material. If material is not included in the chapter's Creative Commons license and your intended use is not permitted by statutory regulation or exceeds the permitted use, you will need to obtain permission directly from the copyright holder.





# Equity and Justice in Climate Change Adaptation: Policy and Practical Implication in Nigeria

# 87

Chinwe Philomina Oramah and Odd Einar Olsen

## Contents

Introduction .....	1768
Conceptualizing Justice and Equity as It Relates to Climate Change Adaptation .....	1770
Climate Change in Nigeria .....	1771
Preparing for Climate Change Adaptation in Nigeria .....	1772
Exploring the Equity and Justice Perspective of Climate Change Adaptation in Nigeria ...	1773
Vulnerability and Impact of Climate Change in Nigeria .....	1775
Adaptation Policies and Practices in Nigeria .....	1779
Policy Implications of Adaptation Governance in Nigeria .....	1779
Actors Perspective on Adaptation Governance in Nigeria .....	1780
Equity and Justice in Adaptation Policies and Practices in Nigeria .....	1781
Conclusion .....	1783
References .....	1784

## Abstract

Over the past decade, justice and equity have become a quasi-universal answer to problems of environmental governance. The principles of justice and equity emerged as a useful entry point in global governance to explore the responsibilities, distribution, and procedures required for just climate change adaptation. These principles are designed primarily through the establishment of funding mechanisms, top-down guides, and frameworks for adaptation, and other adaptation instruments from the UNFCCC process, to ensure effective adaptation

This chapter was previously published non-open access with exclusive rights reserved by the Publisher. It has been changed retrospectively to open access under a CC BY 4.0 license and the copyright holder is “The Author(s)”. For further details, please see the license information at the end of the chapter.

C. P. Oramah (✉) · O. E. Olsen

Department of Safety, Economics, and Planning, University of Stavanger, Stavanger, Norway  
e-mail: [chinwe.p.oramah@uis.no](mailto:chinwe.p.oramah@uis.no); [oddeinar.olsen@uis.no](mailto:oddeinar.olsen@uis.no)

© The Author(s) 2021

W. Leal Filho et al. (eds.), *African Handbook of Climate Change Adaptation*,  
[https://doi.org/10.1007/978-3-030-45106-6\\_45](https://doi.org/10.1007/978-3-030-45106-6_45)

1767



for vulnerable countries like Nigeria that have contributed least to the issue of climate change but lack adaptive capacity. Global adaptation instruments have been acknowledged for adaptation in Nigeria. Climate change has a detrimental impact on Nigeria as a nation, with the burden falling disproportionately on the local government areas. As Nigeria develop national plans and policies to adapt to the consequences of climate change, these plans will have significant consequences for local government areas where adaptation practices occur. Although the local government's adaptation burden raises the prospects for justice and equity, its policy and practical implication remains less explored. This chapter explores the principles of justice and equity in national adaptation policy and adaptation practices in eight local government areas in southeast Nigeria. The chapter argues that some factors make it challenging to achieve equity and justice in local adaptation practices. With the use of a qualitative approach (interview (n = 52), observation, and document analysis), this chapter identified some of the factors that constraints equity and justice in local government adaptation in southeast Nigeria.

---

**Keywords**

Adaptation policy · adaptation practices · environmental justice · equity · Nigeria · local level

---

**Introduction**

The gap between the developed and developing nations as regards development is extending to the risks and security issue of climate change. While almost all countries are affected by the risk and security impacts of climate change, it is widely recognized that developing countries are more vulnerable, lacks adaptive capacity (Tabbo and Amadou 2017), and would suffer disproportionately (Stallworthy 2009; Rübhelke 2011). This is particularly the case for developing countries in Africa living in poverty (IPCC 2014). Wide recognition that industrialized countries are overwhelmingly responsible for climate change has slowly led to conceptualizing adaptation as a global issue with a formidable dilemma of equity and justice in developing countries such as Nigeria (McManus et al. 2014; Thomas and Twyman 2005). Scaling adaptation as a global issue recognizes an international responsibility to provide financial support and funding for undertaking adaptation at the national or local level in developing countries (Benzie and Persson 2019; Cipler et al. 2013; Saraswat and Kumar 2016). Despite the funds obtained by some developing countries for climate change adaptation, implementing adaptation at the local level continues to be challenging.

Many of the impacts of climate change, such as floods and drought, are experienced at the local level (Rauken et al. 2015). As a result, the burden of climate change adaptation practices falls disproportionately on the local government area. Adaptation is a localized phenomenon that addresses local circumstances with the

need for local solutions and actions (Corfee-Morlot et al. 2011; Measham et al. 2011; Moore 2012; Nalau et al. 2015). Conceptualizing climate change adaptation as a local phenomenon is based on the principle of subsidiarity, which is a belief that tasks should be trusted with the lowest level, where the local actors are always able and willing to govern their natural resources effectively (Lockwood et al. 2009). This approach to adaptation assumes that local actors have the required resources to practice adaptation in isolation.

However, local government in Nigeria is embedded in a broader multiscale governance context comprising a range of government actors from the state, the federal, and global levels. Thus, current thinking poses that adaptation plans should be understood and developed at national and subnational levels, practiced at the local level, and funded via international institutions (Benzie and Persson 2019). As a result, local adaptation is increasingly supporting and driving adaptation initiatives and policies within the framework provided by national and state-level legislation (Vogel and Henstra 2015). The extent to which these adaptation policies consider vulnerabilities and impacts of climate change at the local level as well as the extent to which local government participates in instituting national adaptation policies and frameworks are debatable. Against this backdrop, different scholarly voices have emerged over the years, arguing that adaptation decision-making at policy and practical levels has justice and equity implications (Few et al. 2007; Paavola and Adger 2006; Thomas and Twyman 2005).

Nigeria has instituted national adaptation plans and policies as well as established climate change institutions to aid adaptation. Despite the adaptation policies and institutions, some local government areas struggle to cope with and respond to climatic impacts. This is because there are no regulations and institutions designed to foster climate change adaptation in the local government area (Oulu 2015). Presently, the local government institutions carrying out adaptation, such as the ministry of environment and planning, department of works, and local emergency management agency (LEMA), are not designed for climate change challenges. This chapter discusses prospects for justice and equity principles in Nigeria's national adaptation policy and local adaptation practices. This chapter affirms that equity and justice are the important normative goal in both national and local climate change adaptation, but argue that the practice of equity and justice in climate change adaptation is often embedded in the illusion of inclusion. Without due consideration of equity and justice at all levels of governance, there would be a tension between the underlying principle of fair adaptation and participation by the local governments and vulnerable groups in Nigeria. Alternatively, a more instrumental approach to appropriate adaptation at the local level is more likely to succeed as long as local government inclusion is made explicit from the outset.

This chapter discusses the perceived role of equity and justice regarding national adaptation policy at the federal level and adaptation practices in eight local government areas in southeast Nigeria. With the use of a qualitative approach through interview and document analysis, this chapter explores the principles of equity and justice in policies and practices of climate change adaptation in Nigeria.

## Conceptualizing Justice and Equity as It Relates to Climate Change Adaptation

Climate change issues give concern for different types of justice: distributive, procedural, recognition, compensatory, and restitutive justice (Ciplet and Roberts 2017; Khan et al. 2019; Klinsky and Dowlatabadi 2009; Rawls 1971). The basic structure in the subject of climate change justice here is that different communities experience differentiated impacts of climate variability in part by the political system as well as by economic and social circumstances. This differentiated physical and social vulnerability to climate change impacts create deep inequalities between developing and developed countries. Vulnerable developing countries lack the tools and adaptive capacity required to develop the appropriate response to climate risks. The development of tools and adaptive capacity both at the local and national level has been a significant focus on global adaptation, especially regarding equity and justice. However, equity and justice issues of adaptation are more readily discussed at the global, regional, and national levels than at the local level (Thomas and Twyman 2005), even though adaptation practices are undertaken at the local level.

At the global level, the differentiated vulnerability to the impact of climate issues was brought to the international community's attention in November 2006 at the United Nations Framework Convention on Climate Change (UNFCCC) held in Nairobi, intending to identify situations that increase or reduce the capacity to adapt (Vogel et al. 2007). It was then argued that adaptation would promote benefits that can lead to equitable and sustainable development (Adger et al. 2009). The 2015 Paris Agreement includes a global goal on adaptation through reducing vulnerability to climatic impacts, reinforcing adaptive capacity, and strengthening resilience (International Summit on Climate Change held in Paris 2015). One of the commitments of developed countries under the UNFCCC is to assist developing countries to meet their adaptation cost. If more impoverished country gains access to adaptation funds through equity and justice schemes, adaptation can be improved. Global governance is considered especially relevant for Nigeria and other developing countries, as these countries are already struggling to meet climate change's security challenges (Nightingale 2017; Nath and Behera 2011). The principle of environmental justice is focused on the existence of inequity in the distribution of environmental hazards, where the environment is understood to create a condition for social justice (Schlosberg 2013). As climate change increases, environmental justice is given more broad consideration with a growing focus on sustainability and transformative politics and practice to affirm the socio-ecological unity and the interdependence of all species.

There are essential points to why equity and justice have become two crucial concepts in climate change adaptation discourse at the global and national levels. First is the principle of justice, which emerges as a reaction to the claim that devastating climate extremes such as flood, drought, and desertification made worse by climate change pose additional negative implications for vulnerable developing countries and poverty-affected communities (Nay et al. 2014). The susceptibility to climate risk goes beyond biophysical vulnerability to include human well-being, social, economic, and political factors underlying social vulnerability (Kelly and Adger 2000; Otto et al. 2017), which put vulnerable countries in a

constant state of crises. Therefore, adaptation should be evaluated based on justice criteria that would benefit all groups of society as well as the future generation by providing the information and resources needed for adaptation, especially for those most vulnerable to climate change impacts.

Second, equity is a concept referring to fairness in the distribution of outcomes or distributive equity (Miller 1992). As regards climate change, Nay et al. (2014) argue that developing economies depend more on climate-sensitive activities that are more impacted by climate variability. They argue further that these developing economies also lack the political and organizational capacity to adapt to climatic impacts. Thus, the outcome of the equity principle should ensure that:

- The vulnerable are treated fairly for unduly bearing the burdens of climate change impacts
- There is an inclusive decision-making process
- There is an inclusive framework for taking and facilitating adaptation action
- There is a relationship between climate change adaptation and other factors that affect livelihoods (McManus et al. 2014)

However, within these developing countries, the social, institutional, and political structures can play an essential role in climate change adaptation. The relationships that exist between the individuals, the communities, and the state are also essential. Thus, adaptation at the local government is often enabled or hindered by other issues such as social structures, power relations, political and institutional structures, as well as the broader higher level of governance arrangements (Lawrence et al. 2015; Simonsson et al. 2011). These relationships often reaffirm the status quo and are likely to influence the issues of equity and justice in local adaptation practices. According to Eriksen et al. 2015, injustice and unfairness exist when the politically powerful actors set up institutions that advance agendas that exclude local knowledge, needs, and voices of the marginalized in adaptation decision-making. These powerful actors with authority further influence adaptation by claiming the right to legitimize or undermine different types of knowledge (Eriksen et al. 2015). Adaptation policies are often designed at the national level and may disproportionately affect vulnerable communities if they are excluded during policy design (Urwin and Jordan 2008). Understanding the local context of vulnerability through local participation in adaptation policies is essential for equitable and justifiable adaptation. This implies a process of social interaction and joint decision-making by stakeholders across governance scale in adaptation. However, from a systems perspective, one of the challenges facing such provision is associated with the complexity of social interactions involved in multilevel adaptation decision-making.

---

## Climate Change in Nigeria

Nigeria is one of the most vulnerable countries and is highly dependent on climate-sensitive sectors. The country is located in the tropics that give her a hot tropical climate, consisting of variable rainy and dry seasons depending on location. Given the country's climatological cycle and size, there is a considerable range in total

annual rainfall across Nigeria, from south to north, and in some regions from east to west. Wet and dry season prevails in the east and west, while a steppe climate with little precipitation is found in the far north. Temperature and humidity remain relatively constant throughout the year in the south, while the season varies considerably in the north (Ajayi et al. 2019). The most significant total precipitation is in the southeast along the coast around Bonny (south of Port Harcourt) and east of Calabar with annual rainfall around 4,000 millimetres (mm). The regularity of drought periods has been among the most notable aspects of Nigeria's climate in recent years, particularly in the north's drier regions (Akande et al. 2017; Haider 2019). These droughts indicate the considerable variability of climate across tropical Africa and severely affect the drier margins of agricultural zones occupied primarily by pastoral groups.

The southeast is one of the most developed regions in Nigeria, with the second-highest population density. In 2015, the southeast had a total population of 40 million. Southeast Nigeria falls within the latitude of 6' N and 8' N and longitude of 4'30'E and 7'30'E, describing the country's inland region. Southeast Nigeria is of the wet tropical type climate with mean annual temperatures between 21 °C and 34 ° C. The temperature is highest around March in the southeast (Iloeje 2009). The mean minimum temperature is relatively close to the coastal area, with annual rainfall exceeding 3500 mm (Njoku 2006; Nwagbara et al. 2013). In recent years, rainfall has become significantly more substantial in the southeast. In 2012, River Niger reached a record of 12.84 m above sea level. Water levels have also risen in upstream Cameroon, Mali, and Niger. These countries feed the River Niger and River Benue, which flow through Nigeria. River Niger flows through the southeast region leading to severe flooding. In 2012, flooding led to two million displacements and three hundred and sixty-three (363) deaths. In 2017, 12 states, including states in the southeast, were severely affected, leading to 200 deaths and over 600,000 displacements (Orji 2018). As climate change leads to more rainfall, floods disasters are becoming more devastating in Nigeria, especially in the southeast region. The southeastern region is also exposed to mild drought during the dry season.

## **Preparing for Climate Change Adaptation in Nigeria**

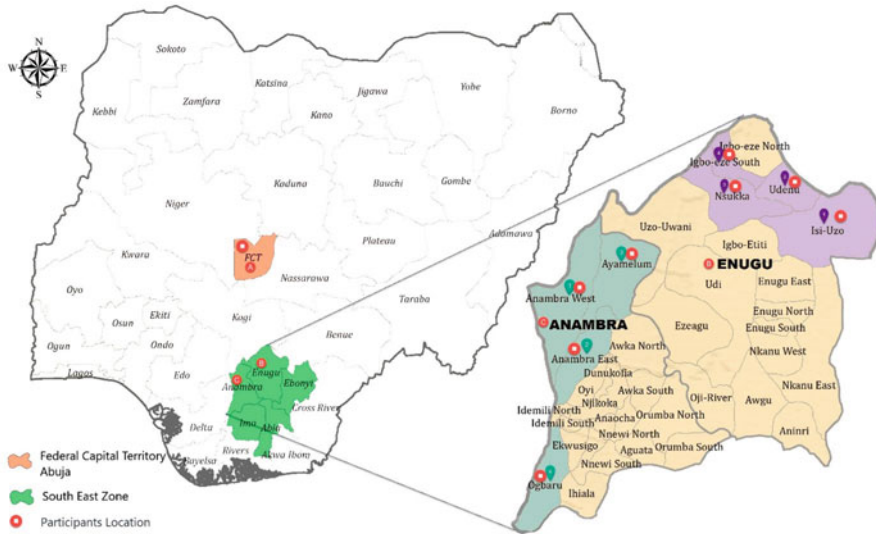
Nigerian started showing a keen interest in climate change issues since 1994. The first national climate communication in 2003 was aimed at shedding more light on the consequences of climate change and its impact on developmental goals. With the support of development partners such as the United Nations Development Program (UNDP), the European Union (EU), United States Agency for International Development (USAID), as well as intergovernmental, regional organizations and nongovernmental agencies, several climate change adaptation strategies and policies have been designed and approved. Nigeria initiated a comprehensive planning process for adaptation by developing the National Adaptation Strategy and Plan of Action on Climate Change for Nigeria (NASPA-CCN). Prioritized adaptation measures in the NASPA-CCN report tend to focus on agriculture, forestry, water

resources, human health, human settlement, energy, transportation and communication, industry, disaster and security, livelihoods, vulnerable groups, and education. In NASPA-CCN report, there is a recognition that climate change adaptation can best be achieved through multilevel effort requiring global, national, state, local government, nongovernmental, and civil society coordination (BNRCC 2011). In addition to this, Nigeria has instituted policies and established climate change institutions to aid adaptation. Policies such as National Policy on Erosion and Flood Control, National Water Policy, Nigeria Drought Preparedness Plan, National Forest Policy, National Health Policy, the National Policy on Environment supports (for prevention and management of disasters such as floods, drought, and desertification) and Nigeria's Agricultural Policy were developed to protect agricultural land resources from drought, desert encroachment, soil erosion, and floods (BNRCC 2011). Nigeria has established a climate change framework such as the National Framework for Application of Climate Services – NFACS (to reduce communities' vulnerability by implementing the National Agricultural Resilience Framework for the agricultural sector). Nigeria has also established a climate change department under the federal ministry of environment. The country relies on NIMET (Nigerian Meteorological Agency) and NEMA (National Emergency and Management Agency) for climate-related disaster warnings, prevention, and response. At the state level, departments of climate change are functional in some states and non-functional in others. There are no known climate change departments at the local government areas; hence, existing ministries are carrying out adaptation actions.

## **Exploring the Equity and Justice Perspective of Climate Change Adaptation in Nigeria**

This section of the chapter takes an equity and justice perspective of adaptation policy and practice in Nigeria, which provides a useful framework for understanding the factors that promote or hinder local government adaptation. The local government areas that are the focus of the chapter are situated in the southeast zone, where the population is (a) vulnerable to climate-related floods and mild droughts, (b) lack adaptive capacity, and (c) agitating for separation from Nigeria due to poor social and political representation. Interviews, observation, and document analyses were used as the primary data sources to explore the perceived impact of equity and justice on national adaptation policies and local adaptation practices in southeast Nigeria. This chapter analyzed the national adaptation plan and other important documents. The key documents analyzed include the National Adaptation Strategy and Plan of action on Climate Change for Nigeria (NASPA-CCN) and Nigeria Intended Nationally Determined Contribution (INDC 2016). Other documents include scientific articles, policy documents, newspapers, conference speeches, and media contents (Fig. 1).

Interviews and observations were carried out between September 2017 and January 2018. The interview was conducted ( $n = 52$ ) with actors working at the federal, the state, and the local government parastatals. At the national level, ten



**Fig. 1** Map of Nigeria showing the participant's locations

participants from the federal department of climate change were interviewed. These federal-level participants are labeled FGP (Federal government participant). At the regional level, ten participants from two states in the southeast (Anambra and Enugu state) were interviewed, where five participants were selected from each state. These participants are involved in adaptation across the state ministry of ecology, environment and climate change, the state ministry of works, and the state emergency management agency (SEMA). The state-level participants are labeled SGP (state government participants). At the local government level, 32 participants were interviewed from eight local government areas in southeast. Four experts were selected from each of the eight local government areas. These local government-level participants are labeled LGP (Local government participants). Among these participants are engineers involved in areal planning and infrastructural management, officials engaged in environmental protection, and local emergency management agencies (LEMA). Four of the local government areas, Anambra east, Anambra west, Ayamelum, and Ogbaru, are situated very close to water bodies. With the majority of the population living near the riverine area, flooding is the largest source of climate-related losses. The other four local government areas, Igbo-Eze south, Isiuo, Nsukka, and Udeni, are situated in highlands where both floods and mild droughts are sources of climate-related losses affecting the population. Flood and drought in the southeast impact livelihood, health, crop production, livestock, groundwater dryness, and infrastructure damage. Interview questions focused primarily on how fair adaptation policies are for local government adaptation practices.

The observation was used to collect data on the adaptation practices and activities designed to cope with climate-related disasters. Data obtained through the

observation method were noted and analyzed based on a follow-up question for confirmation. The interview, observation, and document analysis data were coded and categorized using Nvivo 11. The data was identified and categorized thematically using the inductive and data-oriented approach. The findings will be analyzed using the following questions as a structuring tool: what are the physiological and social vulnerability of climate change in the eight southeast local government areas in Nigeria? How is Nigeria adapting to climate change impacts? Who is responsible for adaptation policies and practices? What role do the principles of equity and justice play in adaptation in Nigeria's local government areas? These questions would be explored in three subsections. The first section will give an account of the vulnerability of local government areas to climate change. The second subsection will explain how global adaptation is affecting Nigeria's adaptation policy and practices. The last section will then explain the effect of global equity and justice on local adaptation practices.

---

## **Vulnerability and Impact of Climate Change in Nigeria**

Climate change in Nigeria leads to changes in the frequency and intensity of weather and climate extremes. Nigeria's climate extremes hit people in multiple different ways. Warm temperatures cause more evaporation of water, while changes in precipitation lead to heavy rain but also swings into drought conditions. Nigeria is one of the most vulnerable countries to climate variability (IPCC 2014). The most frequently cited vulnerability is sea level rise, floods, droughts, sandstorms, landslides, erosion, intensified desertification, and general land degradation (Medugu et al. 2010). These extreme events have broad consequences for farmlands, livestock, and built infrastructures such as buildings, roads, and railways, as well as fundamental societal concerns, such as disputes over environmental resources, food security, water security, health implications, loss of livelihoods, internal and external migration, and loss of life (BNRCC 2011; IPCC 2014). The broad consequences of climate change make it imperative to assess the level of a country's vulnerability to climate change and capacity and readiness for adaptability. This chapter identified vulnerability to climate change at the national, regional, and local levels. Some vulnerability factors are frequently identified across all three scales: poverty, access to resources, livelihood opportunities, and health. Vulnerability to climate change is distributed disproportionately in Nigeria. The northeast and northwest zones are vulnerable to desertification, heat wave, loss of freshwater, intensive drought, bush burning, loss of arable lands, and livestock loss. The southeast and southwest are vulnerable to sea level rise and salinization, intensive rainfalls, floods, and damages to built infrastructures. It would be nearly impossible for preparation to be made towards adapting to these changes if the vulnerability is not adequately understood, especially from the angle of the most affected parties at the local level.

The IPCC conceptualizes vulnerability as a function of the state of a social system and the biophysical nature of climate change effects that the system face (IPCC 2007). Vulnerable to climatic impacts, Nigeria covers different frameworks.



These include risk hazards, political ecology, and socio-ecological system frameworks. Within the risk and hazard field, vulnerability is the susceptibility of people and things to losses attributable to a given level of danger, a given probability that a hazard would manifest itself in a particular way, and with a particular magnitude (Alexander 2002: 29). This field of vulnerability often neglects to address how human contribute to climatic hazards as well as the societal context in which climate hazards takes place. In political ecology, vulnerability is a characteristic of a person or group and their situation that influences their capacity to anticipate, cope with, resist, and recover from the impact of a natural hazard (Wisner et al. 2004). In the social-ecological system framework, vulnerability is a state of susceptibility to harm from exposure to stress associated with environmental and social change and the absence of capacity to adapt (Adger et al. 2006). Multiple factors such as environmental exposure, socioeconomic, political, and cultural factors operating at different levels drive vulnerability in Nigeria's local government areas. Climate hazards only lead to disaster if there is biophysical or/and social vulnerability. Biophysical vulnerability to climate change is understood as a function of environmental exposure, while the social vulnerability is a function of socioeconomic, political, and cultural characteristics of a society (Otto et al. 2017).

In Nigeria, vulnerability plays out locally. This chapter attempt an assessment of some local government areas' vulnerability to climate-related flood and drought around two dimensions, biophysical vulnerability and social vulnerability. Results show some similarities in the participant's perception of climatic impacts and adaptation measures.

Table 1 shows that flooding is the largest source of climate-related losses in four low land, local government areas in the southeast, as the participants explained. With an estimated 30% of the population living near the riverine area, in Anambra east, Anambra west, Ayamelum, and Ogbaru, loss of house settlement, loss of farmland, transportation, limited energy supply, and erosion are constant plight experienced by local communities. Out of 16 participants from low land, local government areas 14 have experienced vulnerability to flooding while 2 knows people that have experienced flood vulnerability. LG participants explained that during flooding, the only transportation system is local boats. However, they argue that using resilient structures such as iron and other metallic products to construct roads and bridges can make the situation better. Flooding causes desperate living conditions leading to the temporal fleeing of millions of people. The electric power supply in the southeast is limited at ordinary times. Flood hazards negatively influence the already limited power supply, forcing households and businesses to use generators that emit CO<sub>2</sub> and other dangerous gasses to the detriment of human health and environmental safety.

Table 1 illustrates the frequently identified adaptation strategies used to adapt to the effect of climatic hazards. The various adaptation measures identified by LG participants are flood management, town planning, and waste management. Flood management takes place through the construction of an effective drainage system. LGP participants explained that the local communities' drainage system is weak as some drainage systems are poorly constructed. Rainwater leads to overflow and

**Table 1** Local government physical and social vulnerabilities and adaptation strategies

	Local Government Area	Climate change hazards	Biophysical vulnerability to climatic hazards	Social vulnerability to climatic hazards	Effects of climatic hazards	Adaptation strategies
Lowland	1.1) Anambra east 2) Anambra west 3) Ayamelum 4) Ogburu	Floods	Very vulnerable to exposure	1) Economic 2) Governance 3) Infrastructures	1) Loss of farmland, 2) Loss of housing 3) Erosion 4) Poor transportation 5) Energy 6) Migration	1) Flood management 2a) Avoid building on flood plains 2b) Use resilient infrastructure 3) Soil management 4) Resilient infrastructure and drainage system. 5) Energy and infrastructure management
Highland	1.1) Igbo-Eze South 2) Isiuo 3) Nsukka 4) Udenu	Mild droughts  Floods	Very low  Moderately vulnerable to exposure	1) Lack of economic resources 2a) Dysfunctional government structure 2b) Lack of important institutions	1) Agriculture, 2) Water distribution  1) Agriculture 2) Erosion 4) Transportation 4) Water security 5) Energy 6) Migration	1) Irrigation 2) Use of deep water and boreholes  1) Improve the agricultural system 2) Conservation agriculture and soil management 3) Use of resilient materials and functional drainage system 4) Water resource management 5) Energy and infrastructure
		Mild drought	Moderately vulnerable		1) Agriculture 2) Water distribution	1) Irrigation technology 2) Use of underground water

flood incidents because the drainage systems are often not appropriately channeled. Poor town planning leads to improper house settlements where people construct houses on floodplains. LGP participants agree that communities must adhere to town planning to avoid the loss of house settlements. Proper town planning discourages people from building on floodplains and using resilient structures that can withstand extreme weather variability. Poor waste management leads to people's disposal of waste when it is raining. These wastes block the drainage system and contribute to flooding.

Erosion is another hazard linked to climate variability in the low land, local government areas of southeast. LGP participants explain that people have lost their houses and farmlands to erosion. They also explain that erosion losses are not as severe as losses from the flood as erosion occurs slowly. LGP mentioned soil management and planting of trees as necessary measures used to reduce erosion. In Anambra east, Anambra west, and Ogbaru, the LGP participants explained that trees' planting is not sustainable due to firewood consumption.

Slow onset events such as drought are also having a substantial impact on crop production, livestock, and water distribution in low land, local government areas but at a deficient level. The use of irrigation and digging for clean water is common in these local government areas during drought. However, LGP explained that the use of irrigation is constrained by limited irrigation facilities based on available resources.

In the local government areas located in highlands, mainly: Igbo-Eze south, Isiuzo, Nsukka, and Udeno, the LGP participants explained that households are not often in danger of losing their homes due to moderate flooding instead, it is agriculture, gully erosion, road infrastructures, and energy distribution that are impacted. There is an uneven distribution of rainfall, and participants noted that the length of dry periods is on the increase. LGP participants in the local government located in highlands note that drought is a climatic hazard, leading to water shortage, with notable negative impacts on the farmers' crops, livestock, and income. These participants suggest that rainfall is often not sufficient for their agricultural production and household needs. Field observation revealed that different household sources water from streams and boreholes.

Table 1 illustrates that apart from massive flooding in the low land local government area, there are similarities in climate change challenges as well as similarities in adaptation measures in both the low and high land local government areas. The most remarkable difference between the low land local government areas and the high land local government areas is their preparedness. LGP explained that even though climate change is leading to unpredictable rainy seasons, those in riverine areas are often more prepared, which inspires more proactive adaptation strategies. In the Anam community, people come together to construct tall buildings to adapt to floods. Households are often not caught off guard as they proactively get temporal housing settlements and their boats ready for transportation as soon as flood starts.

In all the local government areas, it was indicated that the adoption of the adaptation measures frequently mentioned is moderate due to lack of resources. Though communities in the southeast are already implementing numerous strategies

to cope with climate change, LG participants agree that the adaptation measures are carried out on individual, group, and community levels. The reasons given for low adaptive capacity vary from access to funds, lack of climate change awareness, and lack of human resources in the face of climate change. Nigeria context throws light into how physical vulnerability interacts with social vulnerability in climate change adaptation issues. Looking at climate change as both biophysical and social problems allows political and socioeconomic measures to evaluate the effects on the poor and vulnerable.

---

## **Adaptation Policies and Practices in Nigeria**

### **Policy Implications of Adaptation Governance in Nigeria**

Since UNFCCC first conference in 1995, nations have convened to institute and implement binding climate agreements, either as regards to mitigation or adaptation. These binding agreements have lasting impacts on how global climate treaties and national climate policies evolve. These agreements also help determine how financial resources to adapt are distributed (Gurwitt et al. 2017). Nigeria has been engaging in international climate policy negotiations since 1994 when the country becomes a party to the United Nations Framework Convention to Climate Change (UNFCCC). Nigeria ratified Kyoto Protocol in 2004 and submitted the first national climate communication in 2003 and the second national communication in 2014. United Nations Framework Convention on Climate Change provides funding to developing countries with National Adaptation Plans of Action (NAPAs). Under such treaties, countries are required to develop NAPA to adapt to climate change. Nigeria prepared its National Climate Change Action Plan in 2011, which led to the Nigeria Climate Change Policy's approval in 2012.

NAPA provides Nigeria and other least developed countries (LDCs) with an opportunity to meet their urgent and immediate needs for adapting to climate change. In 2015, Nigeria prepared its Intended Nationally Determined Contribution (INDC) and signed the Paris Agreement in 2017. These policy documents' common objective is to demonstrate political commitment to adaptation and communicate the overall government approach to adaptation. Nigeria's policy plan helps identify climate change impacts and vulnerabilities and identify areas where the country's adaptive capacity can be improved (INDC 2016). Adaptation policy targets different sectors of Nigeria's society such as agriculture, freshwater, coastal resources, forest, biodiversity, health and sanitation, human settlement, energy, transportation and communication, industry and commerce, disaster, migration and security, livelihood, education, and vulnerable groups. Nigeria Climate Change Action Plan and INDC report recognize that achieving an adaptation goal would require international support due to its low adaptive capacity. As explained in (BNRCC 2011), Nigeria National Adaptation Strategy and Plan of Action on Climate Change, Nigeria seeks to:

- Detail financial needs assessment to accurately determine the economic costs of climate change adaptation
- Revise the National Fiscal Policy to incorporate the cost of climate change adaptation
- Create a national financing mechanism to support real adaptation needs
- Access necessary international adaptation funding and technologies and manage those funds well

The above are top-down measures that would trickle down to the local level. Within the Nigerian climate policy document, the role of the federal government, the state government, the local government, the private sector, and civil society are made explicit. The federal government is responsible for instituting policies while the local government is responsible for implementing adaptation policies. The issues emphasized in Nigeria's Plan of Action are issues of collaboration, transparency, and finance. BNRCC (2011) report indicates that the federal and state governments would collaborate with the local government to strengthen communities' adaptive capacity by providing:

- Information and technological know-how, facilitating financial and other measures
- Put in place adaptation communication to allow all stakeholders to participate actively in climate change adaptation (NASPA-CCN, 2011)

However, FG participant notes that Nigeria's adaptation policy is increasingly influenced by intergovernmental organizations, as the submission of these documents and reports is relevant to obtain proper support. FG and SG participants explained that adaptation policies encompass climate change issues affecting all Nigerians and strategies to solve those issues. On the other hand, LG participants indicate that the adaptation policy is a one-fit document that lacks knowledge of local problems and solutions. Proposals for an international climate change adaptation policy recognize local representation, even though there are hardly any inquiries to ensure local representation inclusion.

### **Actors Perspective on Adaptation Governance in Nigeria**

FG, SG, and LG participants were asked about their role in climate change adaptation practices. All the FG participants claim that they have engaged in different adaptation practices. Twenty percent of SG participants admitted that they had taken no action but are aware of several adaptation projects. The LG participants claim to have engaged in different adaptation activities such as road construction, house construction, helping community members during rescue operations, and helping to deliver aids.

When asked about who is responsible for climate change adaptation practices, FG and SG participants were quick to point fingers to developed nations. They claim that

Nigeria has benefited from international climate change adaptation funds; however, LG participants explain that individuals and groups carry out adaptation practices on a low scale, as the funds have not translated into effective adaptation practices in the local government areas in the southeast. All participants perceived the role of local government in different ways. The FG participants thought that the local government is getting the necessary resources to help communities address climate change issues. The SG participants are aware of the local government plight as it relates financial and technological resources but insists that the local government is in the position to help local communities adapt.

Interestingly, LG participants think that local government programs to address climate change are indigent. The main reason for this perception appeared to be communication and governance issues. Communication issues bother on perceived lack of consultation and transparency on the part of the state and federal government. The reason for the governance issue included the perception of autonomy and mistrust of the state and federal government. LG participants expressed that federal and state government interferes in local government matters.

When asked about the collaboration in climate change adaptation, the FG participants rate collaboration between the three government levels as excellent. The SG participants rate the relationship between the federal and state government levels as good and state with local government as fair. The LG participants thought there is almost zero collaboration between the local government and other government levels. Eighty percent of LG participants describe the collaboration between the local and the other government levels as servant–master collaboration.

## **Equity and Justice in Adaptation Policies and Practices in Nigeria**

Global equity and justice are essential to plan and mobilize the resources needed to implement adaptation actions. However, it could not be straightforward for international policy to lay claim in sovereign affairs taking place within a sovereign territory. The dilemma of equity and justice in climate change adaptation takes different dimensions in Nigeria. In Nigeria, like many developing countries, contributing minimally to climate change issues, climate variability has become a significant threat to survival and sustainable development, especially for vulnerable individuals and communities (Ilevbare 2019). Nigeria is vulnerable to climate security issues with low adaptive capacity.

On the one hand, there is a top-down international rule system to promote adaptation ambition and accountability. On the other hand, climate change implicates domestic sensitivities in Nigeria. There is a diverging perception of how global equity and justice scheme is impacting Nigeria adaptation policies and practices. The result indicates that there is a fundamental difference between interpretations of equity and justice by FG, SG, and LG participants.

In this section, a perceived overview of adaptation policy and adaptation practices will be presented. A shared perspective on equity and justice is essential not only for transparency but also for ensuring that fair and just adaptation reaches the most

vulnerable people. Those at the federal and state level view adaptation as the responsibility of the developed country that has contributed most to climate change issues, while those at the local level think adaptation is the responsibility of the national and state government. This view is reflected in the policy report, which indicates that Nigeria needs assistance from international, regional, and non-governmental organizations to reach its intended adaptation goals (INDC 2016). LG participants indicate that the vulnerable local government is struggling to meet adaptation requirements despite the fund Nigeria government acquires for adaptation projects. Results show that there are several reasons why justice eludes the vulnerable communities. FG participants claim that Nigeria, as a country, still lacks the technological and financial resources despite funding from international and regional agencies. SG and LG participants agree that resources for adaptation are lacking in all government levels but argue that other factors play a significant role in poor adaptation practices. The common factors mentioned are the institutional context, social structure, power relations, and fiscal capacity for the effective management of natural resources and adaptation funds.

In Nigeria, social structure can be viewed through institutionalized relationships organized around family, religion, education, politics, media, and economy. These institutions organize the social relationship of the southeast to other regions of Nigeria. The southeast and southwest are predominantly Christians, while the northeast and northwest are predominantly Muslims. The different zones with various ethno cultural groups merged into one country in 1914. The different zones have different tribal groups, languages, and cultures. The differences in culture, politics, and tribal identification affect people's relationships with one another. Culture and ethnoreligious politics influence the distribution of resources in Nigeria (Brown 2013).

It was previously found that political corruption and bad leadership affect the southeast zone (Ogundiya 2010). Southeast is a zone where an estimated 50% of the population feel that they are not part of Nigeria. This resentment can be attributed to the Biafra Civil War that killed millions of southeasterners from July 1967 to January 1970. The southeast feels marginalized, leading to some citizens advocating for fresh separation (Olajide et al. 2018). LG participants explained that due to Nigeria's political structure, the southeast lacks resources and infrastructures, which makes adaptation more difficult. Unequal policies and patterns of government structure driven by national and regional political and economic priorities benefit a particular segment of society while making others more vulnerable. Another issue in the southeast is that the service and industry sector are paid more attention at the expense of small-scale agriculture and fisheries (Nzeadibe et al. 2011), even though LG participants note that the farming communities are the most vulnerable in the southeast.

Nigeria operates federalism with an overconcentration of power at the national level (Akinsanya 1999). In this aspect, the politicians at the national level hold a more considerable amount of power to determine what happens to the vulnerable local population as regards climate change impact. Local government lacks autonomy and depends on the state and national government. This dependency leads to

weak institutionalization and local government underutilization, allowing constant intervention from the state and federal government (Acheoah 2018). Adaptation policies are formulated at the state and national levels while adaptation practices take place at the local level. LG participants explained that local knowledge is often not sought during policy formulation, making it challenging to implement such policies in practice. When the state and federal government neglect the most vulnerable participation at the local government, vital communication that encourages collaboration is lost.

Interview and field observation indicate that Nigeria's institutional capacity for climate change adaptation at the federal, state, and local government level is undeveloped and weak. Oulu (2015) argues that establishing effective institutional frameworks is crucial for climate change adaptation. Even with the presence of adaptation policy and climate change department at the federal level, adaptation practices are carried out by the existing National or State Emergency Management Agency (NEMA and SEMA). These two agencies were not designed for climate change adaptation. Only two of the local government areas in the southeast have a Local Emergency Management Agency. NEMA is an existing risk management agency that takes the issue of climate change adaptation as one of its many functions. Climate change adaptation and mitigation goals are now assigned to the ministry and department of the environment. However, LG, SG, and FG participants explain that proven competencies and technological resources in the existing institutions are low.

The budgetary constraint is one of the factors inhibiting adaptation in local communities in Nigeria. However, participants from the federal, the state, and the local government areas have different explanations on how budget constraints hinder adaptation. FG and SG participants claim that budgetary constraints are because of Nigeria's poor economic condition. The LG participants attribute budget constraints to the local government's lack of financial independence. LG participants suggest that the local government also lacked autonomy that contributes to its lack of financial independence required to tackle the issue of climate change adaptation. Fieldwork observation indicates that local government relies on SEMA for relief and settlements for internally displaced people. LG participants explain that the local actors that know the communities well are often not consulted during these visits.

---

## Conclusion

This chapter recognizes that adaptation practices in local governments in southeast Nigeria have equity and justice implications. Environmental equity and justice focus on ensuring that the most vulnerable communities and countries are not left to bear the burden alone. It was argued that climate justice should include mechanisms to ensure that most impacted at the local level have their interests considered (Thomas and Twyman 2005). However, this chapter found that vulnerability to climate change is mostly experienced at the local level, with the burden of adaptation falling disproportionately on the local government areas. Though Nigeria has developed adaptation policies that detail strategies to reduce and avoid climatic impacts, the



local government is excluded from decision-making in adaptation policies, and thereby their vulnerability is often not reflected in the policy documents. This is because climate change adaptation policies and practices at the national level of governance are not open for representative dialogue, especially with the local government's participation. This chapter argues that by excluding the local government in the southeast in adaptation decision-making, the national adaptation plan and policies ignore local adaptation needs and knowledge and do not reflect local vulnerability. Beyond local participation, the interaction between the national authority and local knowledge needs to rely on fairness and accountability. Unless the most vulnerable adapt, risks associated with climate change could increase vulnerabilities, and more inequality.

Financial and technological resources remain crucial in helping the poor and vulnerable communities adapt to climate change risk and climate security issues. Access to these resources is vital for adaptation practices. The United Nations Framework Convention on Climate Change (UNFCCC) provides funding to ensure that the most vulnerable countries are not left to deal with climate change alone. The inclusion of local government in adaptation decision-making will ensure that global funding is easily translated into local practice and that adaptation resources are correctly channeled. This chapter also indicates that it is essential to understand issues such as social structure, power relations, institutional context, and budgetary constraints and how they affect local government adaptation. Thus, local government adaptation practices are not independent of preexisting sociopolitical and governance structures in developing countries like Nigeria. This chapter recommends the local government's inclusion in decision-making and formal adaptation governance to encourage partnership and transparency.

---

## References

- Acheoah OA (2018) Local government: the underutilized governance structure in Nigeria. *Arts Soc Sci J* 9(5):1–4
- Adger WN, Paavola J, Huq S (2006) Towards justice in adaptation to climate change. In: Adger WN, Paavola J, Huq S, Mace MJ (eds) *Fairness in adaptation to climate change*. The MIT Press, Cambridge, MA, pp 1–19
- Adger WN, Lorenzoni I, O'Brien KL (2009) Adaptation now. In: Adger WN, Lorenzoni I, O'Brien KL (eds) *Adapting to climate change: thresholds, values, governance*. Cambridge University Press, Cambridge/New York, pp 1–22
- Ajayi JFA, Kirk-Greene AHM, Udo RK, Falola TO (2019) Nigeria. *Encyclopædia Britannica*. Retrieved from <https://www.britannica.com/place/Nigeria/Resources-and-power>
- Akande A, Costa AC, Mateu J, Henriques R (2017) Geospatial analysis of extreme weather events in Nigeria (1985–2015) using self-organizing maps. *Adv Meteorol* 2017:8576150. <https://doi.org/10.1155/2017/8576150>
- Akinsanya A (1999) Intergovernmental relations in Africa under the 1995 draft constitution. In: Uya E, Uchenna V (eds) *Issues in the 1995 Nigerian draft constitution*. IPPA, Calabar
- Alexander D (2002) *Principles of emergency planning and management*. Terra Publishing, Harpenden, p 29

- Benzie M, Persson Å (2019) Governing borderless climate risks: moving beyond the territorial framing of adaptation. *Int Environ Agreements Polit Law Econ* 19(4):369–393. <https://doi.org/10.1007/s10784-019-09441-y>
- BNRCC (Building Nigeria's Response to Climate Change) (2011) National adaptation Strategy and Plan of Action on Climate Change for Nigeria (NASPA-CCN). Prepared for the Federal Ministry of Environment Special Climate Change Unit. Available at <http://csdevnet.org/wp-content/uploads/NATIONAL-ADAPTATION-STRATEGY-AND-PLAN-OF-ACTION.pdf>
- Brown GM (2013) Nigeria political system: an analysis. *Int J Humanit Soc Sci* 3(10):172–179
- Ciplet D, Roberts JT (2017) Climate change and the transition to neoliberal environmental governance. *Glob Environ Chang* 46:148–156. <https://doi.org/10.1016/j.gloenvcha.2017.09.003>
- Ciplet D, Roberts JT, Khan M (2013) The politics of international climate adaptation funding: justice and divisions in the greenhouse. *Glob Environ Polit* 13(1):49–68. [https://doi.org/10.1162/GLEP\\_a\\_00153](https://doi.org/10.1162/GLEP_a_00153)
- Corfee-Morlot J, Cochran I, Hallegatte S, Teasdal PJ (2011) Multilevel risk governance and urban adaptation policy. *Climate Change* 104(1):169–197
- Eriksen SH, Nightingale AJ, Eakin H (2015) Reframing adaptation: the political nature of climate change adaptation. *Glob Environ Chang* 35:523–533. <https://doi.org/10.1016/j.gloenvcha.2015.09.014>
- Few R, Brown K, Tompkins EL (2007) Public participation and climate change adaptation: avoiding the illusion of inclusion. *Clim Pol* 7(1):46–59. <https://doi.org/10.1080/14693062.2007.9685637>
- Gurwitt S, Malkki K, Mitra M (2017) Global issue, developed country bias: the Paris climate conference as covered by daily print news organizations in 13 nations. *Clim Chang* 143(3):281–296. <https://doi.org/10.1007/s10584-017-2004-2>
- Haider H (2019) Climate change in Nigeria: impacts and responses. K4D helpdesk report 675. Institute of Development Studies, Brighton
- Ilevbare FM (2019) Investigating effects of climate change on health Risks in Nigeria (Online First), IntechOpen. <https://doi.org/10.5772/intechopen.86912>. Available from: <https://www.intechopen.com/online-first/investigating-effects-of-climate-change-on-health-risks-in-nigeria>
- Iloje NP (2009) A new geography of Nigeria, 5th ed. Longman, Nigeria
- INDC (2016) Nigeria's intended nationally determined contribution. Available at [http://www.4.unfccc.int/ndcregistry/PublishedDocuments/Nigeria%20First/Approved%20Nigeria's%20INDC\\_271115.pdf](http://www.4.unfccc.int/ndcregistry/PublishedDocuments/Nigeria%20First/Approved%20Nigeria's%20INDC_271115.pdf). Accessed, October 2017
- IPCC (2007) Climate change 2007: impacts, adaptation and vulnerability. In: Parry ML, Canziani OF, Palutikof JP, van der Linden PJ, Hanson CE (eds) Contribution of Working Group II to the fourth assessment report of the Intergovernmental Panel on Climate Change. Cambridge University Press, Cambridge, p 976
- IPCC (2014) Climate change 2014: impacts, adaptation, and vulnerability. In: Contribution for Working Group II to the fifth assessment report of the Intergovernmental Panel on Climate Change. Cambridge University Press, Cambridge, UK
- Kelly PM, Adger WN (2000) Theory and practice in assessing vulnerability to climate change and facilitating adaptation. *Clim Chang* 47:325–352. <https://doi.org/10.1023/A:1005627828199>
- Khan M, Robinson S-a, Weikmans R, Ciplet D, Roberts JT (2019) Twenty-five years of adaptation finance through a climate justice lens. *Clim Chang*. <https://doi.org/10.1007/s10584-019-02563-x>
- Klinsky S, Dowlatabadi H (2009) Conceptualizations of justice in climate policy. *Clim Pol* 9(1):88–108. <https://doi.org/10.3763/cpol.2008.0583b>
- Lawrence J, Sullivan F, Lash A, Ide G, Cameron C, McGlinchey L (2015) Adapting to changing climate risk by local government in New Zealand: institutional practice barriers and enablers. *Local Environ* 20(3):298–320. <https://doi.org/10.1080/13549839.2013.839643>
- Lockwood M, Davidson J, Curtis A, Stratford E, Griffith R (2009) Multi-level environmental governance: lessons from Australian natural resource management. *Aust Geogr* 40(2):169–186. <https://doi.org/10.1080/00049180902964926>

- McManus P, Shrestha KK, Yoo D (2014) Equity and climate change: local adaptation issues and responses in the City of Lake Macquarie, Australia. *Urban Clim*:10, 1–10,18. <https://doi.org/10.1016/j.uclim.2014.08.003>
- Measham T, Preston B, Smith T, Brooke C, Gorrdard R, Withycombe G, Morrison C (2011) Adapting to climate change through local municipal planning: barriers and challenges. *Mitig Adapt Strateg Glob Chang* 16(8):889–909
- Medugu IN, Majid RM, Johar F, Choji ID (2010) The role of afforestation programme in combating desertification in Nigeria. *Int J Clim Chang Strateg Manag* 2(1):35–47. <https://doi.org/10.1108/17568691011020247>
- Miller D (1992) Distributive justice: what the people think. *Ethics* 102(3):555–593. Retrieved March 9, 2020, from <http://www.jstor.org/stable/2381840>
- Moore FC (2012) Negotiating adaptation: norm selection and hybridization in international climate negotiations. *Glob Environ Polit* 12(4):30–48. [https://doi.org/10.1162/GLEP\\_a\\_00138](https://doi.org/10.1162/GLEP_a_00138)
- Nalau J, Preston BL, Maloney MC (2015) Is adaptation a local responsibility? *Environ Sci Pol* 48:89–98. <https://doi.org/10.1016/j.envsci.2014.12.011>
- Nath PK, Behera B (2011) A critical review of impact of and adaptation to climate change in developed and developing economies. *Environ Dev Sustain* 13(1):141–162. <https://doi.org/10.1007/s10668-010-9253-9>
- Nay JJ, Abkowitz M, Chu E, Gallagher D, Wright H (2014) A review of decision-support models for adaptation to climate change in the context of development. *Clim Dev* 6(4):357–367. <https://doi.org/10.1080/17565529.2014.912196>
- Nightingale AJ (2017) Power and politics in climate change adaptation efforts: struggles over authority and recognition in the context of political instability. *Geoforum* 84:11–20. <https://doi.org/10.1016/j.geoforum.2017.05.011>
- Njoku JD (2006) Analysis of the effect of global warming on forest of southeastern Nigeria using remotely sensed data. A PhD thesis Imo State University, Owerri, Nigeria
- Nwagbara MO, Chima GN, Ndukwe-Okoye N (2013) Climate change and soil erosion in the derived savanna of southeastern Nigeria. Being a paper presented at the 37th annual conference of the soil science society of Igeria held at Lafia, Nasara State, 11–15 March
- Nzeadibe T, Egbule C, Chukwuone N, Agu V (2011) Climate change awareness and adaptation in the Niger Delta Rgion of Nigeria. African Technology Policy Studies Network, Nairobi
- Ogundiya IS (2010) Democracy and good governance: Nigeria's dilemma. *Afr J Polit Sci Int Rel* 4(6):201–208
- Olajide BE, Quadri MO, Ojatorotu V (2018) Climate change, human security and good governance in Nigeria. *Afr Renaiss* 15(3):173–196
- Orji S (2018) It rains, it pours, it floods: Nigeria's growing seasonal problem. African Argument. Retrieved from <https://africanarguments.org/2018/11/15/nigeria-floods-growing-problem/>
- Otto IM, Reckien D, Reyer CPO, Marcus R, Le Masson V, Jones L, . . . Serdeczny O (2017) Social vulnerability to climate change: a review of concepts and evidence. *Reg Environ Chang* 17(6):1651–1662. <https://doi.org/10.1007/s10113-017-1105-9>.
- Oulu M (2015) Climate change governance: emerging legal and institutional frameworks for developing countries. In: Leal Filho W (ed) *Handbook of climate change adaptation*. Springer Berlin Heidelberg, Berlin/Heidelberg, pp 1–20
- Paavola J, Adger WN (2006) Fair adaptation to climate change. *Ecol Econ* 56(4):594–609. <https://doi.org/10.1016/j.ecolecon.2005.03.015>
- Rauken T, Mydske PK, Winsvold M (2015) Mainstreaming climate change adaptation at the local level. *Local Environment* 20(4):408–423. <https://doi.org/10.1080/13549839.2014.880412>
- Rawls J (1971) *A theory of justice*, Revised edn. The Belknap Press of Harvard Press, Cambridge, MA
- Rübelke DTG (2011) International support of climate change policies in developing countries: strategic, moral and fairness aspects. *Ecol Econ* 70(8):1470–1480. <https://doi.org/10.1016/j.ecolecon.2011.03.007>
- Saraswat C, Kumar P (2016) Climate justice in lieu of climate change: a sustainable approach to respond to the climate change injustice and an awakening of the environmental movement. *Energy Ecol Environ* 1(2):67–74. <https://doi.org/10.1007/s40974-015-0001-8>

- Schlosberg D (2013) Theorising environmental justice: the expanding sphere of a discourse. *Environ Polit* 22(1):37–55. <https://doi.org/10.1080/09644016.2013.755387>
- Simonsson L, Åsa Gerger S, Karin A, Oskar W, Richard J. T. Klein (2011) Perceptions of risk and limits to climate change adaptation: case studies of two Swedish urban regions. In: Ford JD, Berrang-Ford L (eds) *Climate change adaptation in developed nations: from theory to practice*. Dordrecht: Springer Netherlands, pp 321–334
- Stallworthy M (2009) Environmental justice imperatives for an era of climate change. *J Law Soc* 36(1):55–74
- Tabbo AM, Amadou Z (2017) Assessing newly introduced climate change adaptation strategy packages among rural households: evidence from Kaou local government area, Tahoua State, Niger Republic. *Jamba (Potchefstroom, South Africa)* 9(1):383–383. <https://doi.org/10.4102/jamba.v9i1.383>
- Thomas DSG, Twyman C (2005) Equity and justice in climate change adaptation amongst natural-resource dependent societies. *Glob Environ Chang* 15:115–124
- Urwin K, Jordan A (2008) Does public policy support or undermine climate change adaptation? Exploring policy interplay across different scales of governance. *Glob Environ Chang* 18:180–191
- Vogel B, Henstra D (2015) Studying local climate adaptation: a heuristic research framework for comparative policy analysis. *Glob Environ Chang* 31:110–120. <https://doi.org/10.1016/j.gloenvcha.2015.01.001>
- Vogel C, Moser SC, Kasperson RE, Dabelko GD (2007) Linking vulnerability, adaptation, and resilience science to practice: pathways, players, and partnerships. *Glob Environ Chang* 17 (3):349–364. <https://doi.org/10.1016/j.gloenvcha.2007.05.002>
- Wisner B, Blaikie P, Cannon T, Davis I (2004) *At risk: natural hazards, people's vulnerability and disasters*, 2nd edn. Routledge, London

**Open Access** This chapter is licensed under the terms of the Creative Commons Attribution 4.0 International License (<http://creativecommons.org/licenses/by/4.0/>), which permits use, sharing, adaptation, distribution and reproduction in any medium or format, as long as you give appropriate credit to the original author(s) and the source, provide a link to the Creative Commons license and indicate if changes were made.

The images or other third party material in this chapter are included in the chapter's Creative Commons license, unless indicated otherwise in a credit line to the material. If material is not included in the chapter's Creative Commons license and your intended use is not permitted by statutory regulation or exceeds the permitted use, you will need to obtain permission directly from the copyright holder.





# Climate-Induced Food Crisis in Africa: Integrating Policy and Adaptation

# 88

David O. Chiawo and Verrah A. Otiende

## Contents

Introduction .....	1790
Definition of Key Concepts .....	1791
Methods and Research Design .....	1792
Patterns of Climate-Induced Food Crisis and Adaptation in Africa .....	1792
Spatial Trends of Food Crisis in Africa .....	1792
Climate Change Adaptation Initiatives in Africa .....	1794
Policy Initiatives for Climate Change Adaptation .....	1800
Conclusion .....	1805
References .....	1805

## Abstract

Climate change threatens development and economic growth in Africa. It increases risks for individuals and governments with unprecedented negative impacts on agriculture. Specifically, climate change presents a major threat to food security in Africa for the long term due to the low adaptive capacity to deal with successive climate shocks. There is a need for greater awareness of the trends of food crisis patterns and adaptive initiatives. The objective of this chapter was to analyze the trends of the food crisis in Africa within the past 10 years and adaptive initiatives. Quantitative data analyzed for food security indicators were

---

This chapter was previously published non-open access with exclusive rights reserved by the Publisher. It has been changed retrospectively to open access under a CC BY 4.0 license and the copyright holder is “The Author(s)”. For further details, please see the license information at the end of the chapter.

---

D. O. Chiawo (✉)  
Strathmore University, Nairobi, Kenya  
e-mail: [dchiawo@strathmore.edu](mailto:dchiawo@strathmore.edu)

V. A. Otiende  
Pan African University Institute for Basic Sciences Technology and Innovation, Nairobi, Kenya

obtained from the United Nations Food and Agriculture Organization (FAO) and World Development Indicators (WDI) available at the Environment and Climate Change data portal. Policy and adaptation measures related to climate change were reviewed in 26 countries in Africa, with the view to highlight their integrative nature in enhancing food security. High prevalence of undernourishment was observed in six countries, all in sub-Saharan Africa (SSA) including Chad, Liberia, Central African Republic, The Democratic Republic of the Congo, Zambia, and Zimbabwe. Countries with a high land acreage under cereal production recorded reduced undernourishment. Niger demonstrated effective adaptation for food security by registering the highest crop production index in extreme climate variability. However, Kenya appears to be the most predisposed by registering both high climate variability and below average crop production index. It is observed that diversification and technology adoption are key strategies applied across the countries for adaptation. However, the uptake of technology by smallholder farmers is still low across many countries in SSA.

---

**Keywords**

Climate change adaptation · Climate change adaptation policy · Food security · Smallholder farmers · Africa

---

**Introduction**

Climate change threatens development and economic growth in Africa. It will increase risks for individuals and governments with unprecedented negative impacts across all sectors of the economy. Specifically, climate change presents a major threat to food security in Africa for the coming decade due to low adaptive capacity to deal with successive climate shocks, despite the trend of the rapid pace of population growth. Population growth in sub-Saharan Africa is likely to experience by far the most rapid relative expansion more than doubling to 2.0 billion by 2050 (Bongaarts 2009). The positive population growth is attributed to technology transitions in health care; however, it is expected to generate increased demand for agricultural land and forest products (Brandt et al. 2017), calling for a matching assemblage of technology and policies to enhance food security to limit the possible impact to the environment.

An overwhelming majority of hungry people are found in developing countries, particularly in Africa (Abegunde et al. 2019). With increasing recognition of present and future impacts of climate change, the United Nations Framework Convention on Climate Change (UNFCCC 2006) has identified the poorest people living in developing countries as the most vulnerable due to their dependence on natural resources and rain-fed agriculture for survival. However, agriculture remains the dominant employer of rural residents in Africa (e.g., Kalungu and Leal Filho 2018; Belay et al. 2017; Mutunga et al. 2017; Cobbinah and Anane 2016). Smallholder farming creates opportunities for an estimated 175 million people in Africa, of which about 70% are

women (AGRA 2014). Across the world, smallholder farmers are considered to be disproportionately vulnerable to climate change because changes in temperature, rainfall, and the frequency or intensity of extreme weather events directly affect their crop and animal productivity (Vignola et al. 2015).

The vulnerability of smallholder farmers is a concern because they represent 85% of the world's farmers and provide more than 80% of the food consumed in the developing world; therefore, what happens to smallholder farmers will have significant social, economic, and environmental consequences globally (Vignola et al. 2015). By their sheer numbers and with optimal productivity, they would have a huge impact in addressing food insecurity (Abegunde et al. 2019), but because of low resource capacity, inadequate skills, and lack of enabling policies, they remain susceptible particularly to climate variability in Africa. Climate change adaptation has become necessary to alleviate the impacts of extreme weather events, especially on rural farmers whose primary livelihood is climate dependent (Cobbinah and Anane 2016).

There is a looming food security crisis in Africa for the next decade due to limited adaptive approaches to extreme climatic conditions of drought, floods, and high temperatures due to climate change (Abegunde et al. 2019). IPCC special report suggested that an increase by 2 °C could exacerbate food crises with crops under rain-fed agriculture dropping by 50% in some African countries by 2020 (IPCC 2018). The current and future impacts of climate change have attracted increasing scholarly work on climate change adaptation (Cobbinah and Anane 2016; Burnham and Ma 2016; Lasco et al. 2014) and its widespread incorporation into national policy and international dialogue (IPCC 2007, 2013). Responding to the effects of climate change requires the continuous development of new adaptive initiatives and improvement of the existing ones and enhancing their widespread adoption by smallholder farmers (Kalungu and Leal Filho 2018). Pursuing appropriate adaptation initiatives in line with realities in Africa is thus vital. A recent study highlighted a positive link between public response and the capacity of farmers to adapt to climate change in sub-Saharan Africa (Abegunde et al. 2019). However, a gap exists in critical review of the role of existing climate change adaptation policies in enhancing the adoption of the initiatives. The objective of this chapter is to analyze the spatiotemporal trends of the food crisis in Africa and adaptive approaches with the view to model a framework for climate change adaptation pathway for Africa.

---

## Definition of Key Concepts

This chapter uses the definition of food security by the United Nations Food and Agriculture Organization (FAO) as food is available at all times; that all persons have means of access to it; that is nutritionally adequate in terms of quantity, quality, and variety; and that it is acceptable within the given culture (Silvestri et al. 2015; Conceição et al. 2016; Luximon and Nowbuth 2010). The chapter defines climate change as a change of climate that is attributed directly or indirectly to human activity that alters the composition of the global atmosphere that is in addition to natural climate variability observed over comparable periods (UNFCC 2006). The

chapter adopts the meaning of climate change adaptation (Mutunga et al. 2017) in that adaptation to climate change is the adjustment in natural or human systems in response to actual or expected climatic stimuli or their effects, which moderates harm or exploit beneficial opportunities.

---

## Methods and Research Design

The analysis was based on four World Bank food security indicators including average prevalence of undernourishment, land under cereal production, extreme climate change variability, and crop production index. Dataset was obtained from World Development Indicators (WDI) (WDI available at Environment and Climate Change data portal <http://africaclimate.opendataforafrica.org/kaoatif/world-development-indicators-wdi>). R was for spatial analysis (R Core Team 2020) using shapefile for 52 African countries from Map Library (Map Library is available at <http://www.maplibrary.org/library/stacks/Africa/index.htm>). Both dataset and shapefile used are licensed under CC BY 4 and are open for public access (Publicly available for any use according to open data standards and licenses under the Creative Commons Attribution 4.0 International license (CC-BY 4.0)). Adaptive and policy strategies applied across Africa were reviewed at local, national, and regional scales. Countries were selected based on the undernourished index and vulnerability to climate change. Spatial patterns were analyzed for undernourishment, land under cereal production, crop production index, and climate change variability in all the 52 African countries according to the shapefile. The spatial patterns were used to identify the countries for review of adaptation and policy strategies. High undernourishment prevalence countries above 40% and low prevalence countries below 10% were selected for review of adaptation and policy strategies for comparison and criticism. Additional counties for review of adaptation and policy were selected based on vulnerability to climate change, low or high crop production index, and landmass under cereal production (Figs. 1 and 2). A total of 26 countries were reviewed across Africa with a larger proportion in SSA. The approach presents a conceptual model integrating climate change adaptation and policy initiatives to illustrate the effective pathway to climate change adaptation in Africa for food security.

---

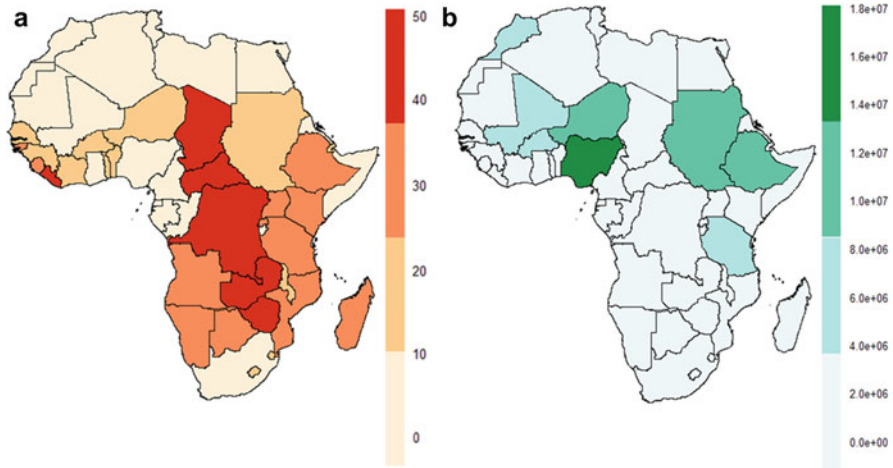
## Patterns of Climate-Induced Food Crisis and Adaptation in Africa

This section is structured in three parts: the first part presents the results of spatial analysis of food security in Africa for the last 10 years, adaptation initiatives in the second part, and policy initiatives in the third part.

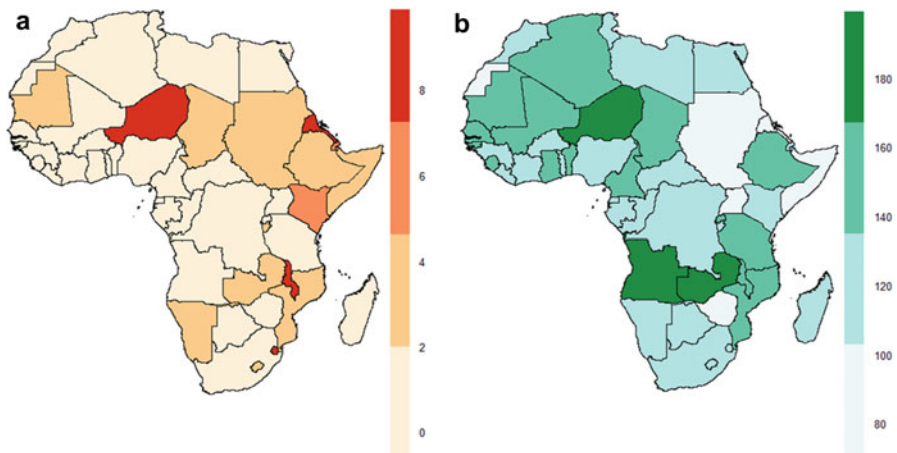
### Spatial Trends of Food Crisis in Africa

The prevalence of undernourishment (PoU) is defined by FAO as an estimate of the proportion of the population whose habitual food consumption is insufficient to





**Fig. 1** Spatial patterns of climate-induced-food crisis in Africa. (a) Average prevalence of undernourishment (% of the population) in Africa for the period 2009–2017. (b) Land under cereal production (hectares) for the period 2009–2017 (Authors own)



**Fig. 2** Spatial patterns of extreme climate change variability and crop production index in Africa. (a): Droughts, floods, extreme temperatures (% of the population). (b): Crop production index for the period 2009–2016 (Authors own)

provide the dietary energy levels that are required to maintain a normal active and healthy life. The spatial trends of undernourishment in the last 10 years reveal a high prevalence of 40–50% in six countries (6), all in sub-Saharan Africa (SSA) including Chad in the Sahel and Central Africa, Liberia in West Africa, Central African Republic and the Democratic Republic of the Congo in Central Africa, and Zambia and Zimbabwe in Sothern Africa. Low prevalence is observed in North Africa with all countries registering below 10% of undernourishment (Fig. 1a).

Countries with a high land acreage under cereal production recorded reduced undernourishment (Fig. 1a). Nigeria had the largest landmass under cereal production in the last 10 years with a peak of 18 million hectares (Fig. 1b). Other countries above the average of landmass under cereal include Sudan, Ethiopia, Tanzania, and Niger. It is predicted that a possible cross-border trade policy or intercountry relationship between neighboring countries could be influencing the production of cereals, e.g., Sudan and Ethiopia and Niger, Nigeria, Burkina Faso, and Mali. Most countries in Southern Africa have lower than average landmass under cereal production. Although South Africa has below average landmass under cereals, the undernourishment prevalence was still low for the period of analysis, a pointer toward effective diversification or technology adoption in climate change adaptation (Fig. 1b).

High incidences of extreme conditions due to climate change including droughts, floods, and extreme temperatures are high in four countries that experienced the highest extreme climate change variability in the last 10 years including Niger, Eritrea, Malawi, and Swaziland. However, these countries registered average to high crop production index an indication of effective climate change adaptation. Kenya appears to be more predisposed to extreme climate change variability in East Africa (Fig. 2a). The leading countries in Africa in crop production are Niger, Angola, and Zambia. A good example of how effective climate change adaptation can lead to food security is Niger, which experiences the highest in extreme climate variability, but registers the highest crop production index. It is important to note that Nigeria had a higher landmass under cereal production (Figs. 1b and 2b), but Niger registered a higher crop production index in the same period pointing toward possibilities of application of multiple adaptive initiatives beyond increasing acreage. Sudan, South Sudan, Eritrea, Somalia, Zimbabwe, and Western Sahara are African countries with the lowest crop production index despite experiencing average and below of extreme climate change variability (Fig. 2).

## Climate Change Adaptation Initiatives in Africa

Scientific evidence indicates that the earth's climate is rapidly changing, owing to increases in greenhouse gas emissions leading to raised average temperature and altered the amount and distribution of rainfall globally (Dasgupta et al. 2014). There is growing evidence that the effects of climate change are expected to be greater than the global average in sub-Saharan Africa due to projections of a warming trend characterized by the frequent occurrence of extreme heat events with a 4 °C warming scenario (Serdeczny et al. 2016), increasing aridity, and a decline in rainfall (Belay et al. 2017). Sub-Saharan Africa is particularly vulnerable to these climatic changes because of overdependence on rainfed agriculture on which the livelihoods of a large proportion of the region's population currently depend (Serdeczny et al. 2016).

There are reports of higher drought risks; extreme weather events such as floods, pests, and high temperatures; and diseases faced by farmers in recent years, exacerbating the food crisis in Africa (Mutunga et al. 2017; IPCC 2018). There is evidence

from the literature that the current impacts are more severe in rural and smallholder farming communities (Cobbinah and Anane 2016) especially in Africa. This presents the logic that an adaptation initiative is promising only if it fulfills the objective of increasing food security, increases resilience, and is adaptive for smallholder farmers (Descheemaeker et al. 2016). Therefore, adaptation is deemed more important in Africa than mitigation (Descheemaeker et al. 2016). There is a need to strengthen adaptive strategies to ensure food security in Africa. Our review categorizes climate change adaptation in Africa under nine (9) key thematic areas including *diversification, ecosystem-based adaptation, climate advisories and information, collective action, technological interventions and innovation, credit facilities, change of patterns, insurance, and capacity building.*

### **Diversification**

Different types of diversification initiatives are applied in Africa including sector diversification, agriculture product diversification and crop diversification, tree-based diversification, and livelihood diversification to adapt to climate change. Diversification provides smallholder farmers with a diversity of diet and improves their income and nutrition security, particularly in sub-Saharan Africa where rainfed agriculture is rampant. For example, Mauritius diversified agriculture with the rapid expansion of industrialization for exports in textile and the development of tourism to promote sector diversification and crop diversification. Also, the Government of Mauritius widened access to lands to be leased out to small planters specifically for agriculture product diversification (Luximon and Nowbuth 2010). While in Mauritius the initiatives to diversify agricultural products seem to be incentivized by the Government, in Kenya, they are largely driven by smallholder farmers through off-farm employment, leasing of land (Kalungu and Leal Filho 2018), mixed cropping and livestock farming (Mutunga et al. 2017), and introducing new crops that are drought resistant or switch to a different variety of the same crop (Crick et al. 2018).

In Morocco, farmers practice crop diversification with intercropped vegetables and tree-based diversification using high-value crop trees (HVC), e.g., drought-tolerant species of fig, almond, and pomegranate and olive varieties (Kmoch et al. 2018). In Ethiopia, farmers practice crop diversification, agricultural product diversification by increasing the integration of crops with livestock, and tree planting. However, reducing the number of meals is common for livelihood diversification to adapt to limited food supply (Belay et al. 2017). In Tanzania, farmers diversify agricultural products by growing vegetables in the off-season and sell livestock during drought, while in South Africa, livelihood diversification and focus on livestock are common in case of crop failure. In Mozambique, farmers diversify to other food sources to meet the dietary needs and shift focus to other means of livelihood beyond agriculture. Farmers in Ghana diversify to enhance food production through multiple cropping, combine improved and local crop varieties, and shift from palm oil to maize and sweet potatoes (Burnham and Ma 2016). Focus on cultivating cash crop (cashew) and engaging in non-farm-based activities, e.g., business, are also common in Ghana. Cashew cultivation is viewed by small landholdings in Ghana as a better livelihood option compared to non-farm-based

activities (Cobbinah and Anane 2016). To adapt livestock husbandry to the effects of the extreme of climate change, rural communities in sub-Saharan Africa have diversified to goats instead of cattle and sturdy African breeds instead of more productive crossbreeds (Descheemaeker et al. 2016). In northwest Tunisia, small ruminant farms are better able to adopt the organic farming system and to adapt to warming or precipitation increases by switching to heat-tolerant animals like goats or crops such as Sulla (Khaldi et al. 2012).

Crop diversification together with the diversification of income from multiple sources (cash and in-kind, farm, livestock, crops, and off-farm) is considered to be key “buffer strategies” smallholder farmers pursue to deal with risks of climate change to agrarian environments in Africa (Silvestri et al. 2015; Cobbinah and Anane 2016; Burnham and Ma 2016; Belay et al. 2017; Khacheba et al. 2018; Mutunga et al. 2017). The effectiveness of diversification initiative has been observed in food-secure female-headed households who allocate twice as much land to HVC, e.g., fruits, such as mango and oranges, and then their food-insecure counterparts (Silvestri et al. 2015). This concept in Malawi has demonstrated a gender perspective in climate change adaptation that could be a wake-up call to many African countries to enhance women’s adaptive capacity and resilience to climate change (Nyasimi et al. 2014). Indigenous fruit tree production for improved nutrition and income is successful in Malawi, Zambia, and Zimbabwe. Fruit consumption has clear health and nutrition benefits such as providing essential micro-nutrients and protecting against chronic diseases. Even though fruit consumption in Africa is low, fruit trees fulfill a vital role in contributing to food security, because the fruit is consumed seasonally at a time when households run out of food (Kiptot et al. 2014). There is a need to extensively explore diversification through fruit trees across many African countries to enhance food security.

### **Ecosystem-Based Adaptation**

Ecosystem-based adaptation is the use of biodiversity and ecosystem services as part of an overall adaptation strategy to help farmers adapt to the adverse effects of climate change (Vignola et al. 2015). There is a rapidly growing interest in ecosystem-based adaptation for its potential social, environmental, and economic benefits (e.g., Cerdán et al. 2012; Namirembe et al. 2014; Vignola et al. 2015). Agroforestry provides environmental and social benefits as part of farming livelihoods. In most documented cases of successful agroforestry establishment, tree-based systems are more productive, more sustainable, and more attuned to people’s cultural or material needs than treeless alternatives (Mbow et al. 2014). Trees or shrubs on farms and forest-agriculture integration are gaining preference among farmers in Africa. Despite the productivity of agroforestry systems, it has not been fully adopted in many African countries, e.g., Kenya’s intention to achieve a 10% target of tree cover on farmers’ acreage is yet to be realized (Oloo 2013). There is a need for more insights into the productivity and environmental performance of agroforestry systems across Africa (Mbow et al. 2014). Agroforestry with leguminous fodder plants to support food requirements for livestock during extreme weather is gaining attention among farmers in sub-Saharan Africa (Cobbinah and Anane 2016). In

Tanzania, farmers focus on planting trees as hedgerows, while in Nigeria on-farm trees are used to shade crops and animals (Burnham and Ma 2016). Tree-based agroforestry is also popular in Morocco where farmers use bi- or triennial trees like olives to increase tree cover on-farm (Kmoch et al. 2018).

Improved tree fallows using leguminous trees are encouraged in maize fields in Malawi, Zambia, and Zimbabwe as low cash-input agroforestry practices to restore soil fertility (Keil et al. 2005). Studies in semi-arid areas in Tanzania showed that agroforestry tree species producing high-quality litter could enhance post-fallow soil nutrient availability and crop yields through mineralization of soil organic matter and green manure (Kimaro et al. 2008). In Mauritius, farmers promote the use of organic farming, using organic manure which is more resistant to drought and also reduces the risk of floods (Luximon and Nowbuth 2010), and in Kenya, farmers using locally available organic matter prepare organic manure (Oloo 2013). Farmers in Morocco adapt to the effects of climate change like floods by encouraging conservation agriculture through minimum tillage and increase of soil cover (Kmoch et al. 2018). Minimum tillage and crop rotation were observed to increase farm maize productivity by about 26–38% for minimum tillage and 21–24% for crop rotation in Zambia (Kuntashula et al. 2014). In sub-Saharan Africa rangeland, farmers practice grazing and rangeland management to enhance manure collection, storage, and application (Descheemaeker et al. 2016).

Planting cover crops and the use of manure for soil conservation to prevent soil erosion and to improve soil fertility respectively are common among small-holder farmers in Tanzania, Kenya, and Ethiopia (Mutunga et al. 2017; Belay et al. 2017; Burnham and Ma 2016). Farmers in Ethiopia are observed to practice both soil and water conservation (Belay et al. 2017). In Burkina Faso, farmers arrange stone lines on-farm and in the field to capture surface runoff for micro-water harvesting and to prevent soil erosion due to flash floods, and in South Africa, farmers build bunds along contour lines to slow down water runoff (Burnham and Ma 2016).

### **Technology and Innovation Adoption**

The adoption of appropriate technologies in small-scale farming is an important response to the effects of climate change and variability, especially in Africa (Kalungu and Leal Filho 2018). Farmers largely apply integrated pest management as a means of pest control (Luximon and Nowbuth 2010). Literature indicates a wide use of technological intervention to enhance adapting dairy farming in Tunisia, e.g., farmers in Tunisia build up fodder reserves in favorable years, increase concentrate distribution, manage nutritional requirements, and promote drinking water ad libitum (Hajer et al. 2018). They are keen on the choice of breed and maximize the use of agri-byproducts as feeds. To improve productivity, farmers in Tunisia enhance irrigation potential at the farm level. Farmers also adjust calving periods by concentrating them within favorable feeding periods (Belay et al. 2017). Building fodder reserves for animals is also documented in Burkina Faso (Burnham and Ma 2016). Farmers in Burkina Faso also overcome the shock of drought by producing dry season vegetables using irrigation and the use of improved seeds.

In Kenya, farmers in semi-arid regions apply a combination of technological interventions under Framing Technologies, e.g., soil fertility management, irrigation soil conservation, and water management row planting and terracing. There is high-level awareness on the use of hybrid crop varieties, pesticides, and changing crop variety depending on climate variability (Mutunga et al. 2017; Kalungu and Leal Filho 2018). Planting short seasoned crops and resistant crop variety and feed preservation for farm animals have also been recognized as key adaptive interventions among Kenya farmers (Oloo 2013). Rotation cropping of cereals and legumes and irrigated fruit trees are common in commercially orientated farming systems in Morocco, with agro-silviculture (growing of trees and agriculture crops together in the same lands at the same time) dominating all irrigated farms (Kmoch et al. 2018). There is input intensification in Ethiopia to enhance farm-level productivity (Belay et al. 2017), and in Tanzania, farmers use well irrigation and plant quick maturing and drought-resistant varieties (Burnham and Ma 2016). Farmers in South Africa increase distances between crop rows and practice irrigation. Farmers in South Africa also plant late-maturing fruit trees to enhance food availability during low harvests (Burnham and Ma 2016). In Ghana, farmers plant high yield varieties (Belay et al. 2017). In other countries relay cropping and mixed intercropping are practiced. By providing nutrients to crops, these technologies can potentially help farmers improve their soils and incomes, thereby improving food security in Malawi, Zambia, and Zimbabwe (Kiptot et al. 2014).

Farmers in many African countries aim at enhancing farm-level productivity by planting early maturing varieties and drought-tolerant crops and changing crop variety to match prevailing weather conditions, e.g., in Nigeria, Mozambique, Angola, and Kenya among other countries (Burnham and Ma 2016). The use of drought-tolerant maize has been documented in Angola, Benin, Kenya, and many other African countries (Nyasimi et al. 2014). Technological intervention in sub-Saharan Africa is observed to enhance sustainable intensification in post-harvest storage, choosing adapted crops and cultivars, intercropping and rotation with dual-purpose legumes, water harvesting, and irrigation to adapt local farmers to the adverse effects of climate change to agro-ecosystems. Similarly, technology is expected to enhance the choice for animal types and breeds that are better adapted to heat stress and dry conditions and to improve the storage of food and feed (Descheemaeker et al. 2016).

Moreover, technologies to reduce post-harvest losses are in consideration; e.g., the use of metal silo technology in household maize storage in Kenya has proved effective in protecting stored grains from attack by storage insect pests, sustaining maize supply while reducing the burden on the natural environment (Gitonga et al. 2013; Tefera et al. 2011). Other adaptation technologies promote water allocation efficiency for irrigation. For example, the water–energy–food (WEF) nexus is promoting the uptake of drip irrigation among smallholder farmers in Morocco (He et al. 2006). WEF technology has been promoted as a demand-side management option for reducing water consumption while maintaining yields, particularly through minimizing nonproductive evaporative losses (Jobbins et al. 2015). In Ethiopia, other technologies that maximize precipitation utilization in dryland are

promoted, e.g., increasing the length of the fallow period before planting to increase the amount of pre-plant stored water in the soil and retention of large amounts of crop residue on the soil surface to decrease runoff (Woyessa and Bennie 2007).

### **Climate Advisory and Extension**

Climate advisories and information offer opportunities to inform farmers of climate-related risks, e.g., agrometeorological advisory program and weather and climate bulletins in Mali, and inform farmers on decisions such as variety selection, planting times, and the timing of inputs in Mali (Carr and Onzere 2018). Access to climate change information and extension services is encouraged in Kenya (Mutunga et al. 2017). However, 76% still have limited access to agricultural extension services (Kalungu and Leal Filho 2018). Extension services enhance access to information about new agricultural technologies and innovations. The use of weather information by farmers in Ghana is well documented (Belay et al. 2017). The use of early warning signs, weather forecasts, and agricultural extension services are indicated as important in enhancing the adaptation of farmers to climate variability in sub-Saharan Africa (Descheemaeker et al. 2016; Mbow et al. 2014). In East Africa, climate advisory and extension services remain low among smallholder farmers leading to limited capacity to use climate data (Atela et al. 2018; Singh et al. 2016) and climate illiteracy (Spires et al. 2014). However, the role of ICTs in scaling climate information services (CIS) is gaining attention (Atela et al. 2018). For example, short-term climate information through community worker initiative in Uganda provides 10-day, monthly, and seasonal weather forecasts to farmers on their mobile phones via SMS (Singh et al. 2016).

Access to weather information is observed to significantly influence the likelihood of adopting improved crop varieties, making adjustments in the timing of agricultural activities and investing in improved land management practices, and increasing fertilizer use among farmers in West Africa (Wood et al. 2014). Risk management practices that generate and disseminate agro-advisory services and weather information are important adaptive initiatives in Africa (Nyasimi et al. 2014).

### **Other Adaptive Initiatives**

*Increasing acreage* as an initiative to enhance productivity is being practiced in some African countries, e.g., about 46.4% of the landmass in Mauritius is under agriculture, to enhance the production of crops and livestock (Luximon and Nowbuth 2010). The basis of increasing farm size is to increase food crop production to overcome low food crop productivity by maintaining normal productivity. However, this approach is facing sustainability concerns, e.g., continuous expansion of farmlands with a further clearing of the forest in Ghana has potential implications for deforestation, which will, in turn, exacerbate climate change in Ghana (Cobbinah and Anane 2016). Collective action involving collaboration among farmers is being practiced by local farmers and households. Community center approach to livestock management in Morocco (Kmoch et al. 2018), cooperatives and community-based development projects in South Africa (Belay et al. 2017), and social production and

natural resource management-related groups in West Africa (Wood et al. 2014) have contributed both to limiting the risks and enhancing the capacity to adapt to climate change.

*Change of pattern* in planting times or moving animals is considered among some farmers in different areas: planting just before the onset of rains and moving animals, changing planting dates, and planting near a river in Kenya and Ghana (Belay et al. 2017; Mutunga et al. 2017; Descheemaeker et al. 2016); planting date adjustment in Ethiopia, Kenya, and Nigeria; planting early as possible after first rain (Belay et al. 2017; Oloo 2013), moving livestock to other areas, store fodder, and selling animals in South Africa (Belay et al. 2017); seasonal herd migration in sub-Saharan Africa (Descheemaeker et al. 2016); and temporary migration in Tanzania (Belay et al. 2017). *Capacity building* of climate change adaptation is recognized as a means of enhancing their ability to adopt desired initiatives related to technology adoption and diversification. Building capacity of farmers on climate change adaptation is documented in Mauritius (Luximon and Nowbuth 2010). In Mali, a farmer observer has been trained to enhance the capacity of most farmers in southern Mali (Carr and Onzere 2018). Capacity building of water user associations combined with local knowledge and scientific expertise is common in Morocco (Kmoch et al. 2018). In Zambia, the capacity of farmers is enhanced through conventional agricultural extension systems and participatory farmer interactions (Kuntashula et al. 2014). *Insurance* as a means of climate change adaptation is at trial in sub-Saharan Africa (SSA) to address climate-related risks faced by farmers (Descheemaeker et al. 2016). Weather-based index insurance is being tried in Mali (Carr and Onzere 2018). Adaptation planning in the form of insurance, with or without external support, is being tried in Kenya and Senegal (Crick et al. 2018). However, these products in general face low rates of adoption across SSA due to weakness of regulatory environment and financial facilities, basis risk, quality and availability of weather data, capacity building of stakeholders (farmer, insurer, and regulator), and lack of innovation for local adaptation and scalability (Ntukamazina et al. 2017).

The use of *credit facilities* has also been documented in Kenya (Mutunga et al. 2017) and Mauritius among other countries (Luximon and Nowbuth 2010). A study in Nigeria found a positive impact of commercial bank credits to food security by up to 8% (Osabohien et al. 2018). However, there is evidence that traditional credit use, among smallholder farmers, is extremely low in SSA (Adjognon et al. 2017), pointing to weak or no policy across many countries to enhance implementation.

## **Policy Initiatives for Climate Change Adaptation**

Climate change is progressively hurting agricultural production in Africa (Kalungu and Leal Filho 2018; Crick et al. 2018; Mutunga et al. 2017; Belay et al. 2017; Burnham and Ma 2016). Adoption of suitable adaptation strategies is thus a prerequisite to supporting the majority of smallholder farmers in reducing the effects of climate change (Hajer et al. 2018; Cobbinah and Anane 2016; Belay et al. 2017; Kmoch et al. 2018). Many factors, among them, are policies and markets and have



been identified to define responses of the farmers to climate change shocks (Peter et al. 2017; Hummel 2016; Magnan et al. 2011; Kalame et al. 2009).

### **Policy to Enhance Diversification and Risk Management**

Climate change adaptation policy in Mauritius made available 200 acres of agricultural land widening access to land for lease to small planters for agriculture diversification enhancing food production in the country (Luximon and Nowbuth 2010). Mauritius government advanced some incentives to farmers to support diversification, e.g., agricultural credit from the bank and subsidy on the price of farm input, guaranteed price for some farm produce, and offered some facilities to livestock breeders. Mauritius has the policy to limit food products locally produced to local consumption, while the country exploits the opportunity of cross-border initiatives (CBI) set by FAO with Madagascar, Mozambique, and Tanzania to increase production for domestic consumption (Luximon and Nowbuth 2010). A similar policy on price control also succeeded in Tunisia by reducing the exposure of Tunisian farmers to the food price volatility in the world markets and cautioning local households from the risk of scarcity in food supply (Chemingui et al. 2001). Participating in trade relations with the European Union (EU) and enhanced political cooperation has promoted the diversification of income sources from the trade of agricultural products (Chemingui et al. 2001).

### **Multi-sectoral Policies on Climate Advisory and Extension**

In Namibia, the national-level development policy context of Vision 2030 guides Namibia's national, long-term development related to climate change adaptation. Climate change is mainstreamed in agriculture, disaster response strategies, and marine resources. The policy strengthens Namibia's meteorological services by supporting the work of the National Climate Change Committee in mainstreaming climate change adaptation and strengthening capacities to respond to it (Crawford and Terton 2016). The National Climate Change Strategy and Action Plan (NCCSAP) in Namibia has a direct link to enhancing climate change adaptation initiatives by setting up adaptation action on diversification of crops to adapt to erratic rainfall. It focuses on the increased use of improved crop varieties, conservation of indigenous livestock breeds, and diversification of livelihoods through tourism and wildlife conservancies (Crawford and Terton 2016). The policy aims to enhance capacities and synergies at individual, local, institutional, national, regional, and systematic levels to ensure successful implementation of climate change response activities and adequate funding resources for effective adaptation (Crawford and Terton 2016).

### **National-Level Policies for Adoption of Ecosystem-Based Initiatives**

Policies on restoration or management of biodiversity and ecosystem services could confer multiple adaptive benefits, e.g., the use of shade trees in coffee farms (i.e., producing coffee as an agroforestry system), and could ensure the continued provision of key ecosystem services like pollination, natural pest control, conservation of water and soils, etc. as well as buffering coffee from extreme temperatures and

rainfall, leading to more stable production under climate-related stresses (Vignola et al. 2015). Despite the growing interest in ecosystem-based adaptation, there has been little discussion of how this initiative could be enhanced among smallholder farmers while ensuring the continued provision of ecosystem services on which farming depends (Vignola et al. 2015). Policies on land use planning, forest-agriculture integration, and landscape-based adaptation are in line with enhancing local adoption of an ecosystem-based approach to climate change adaptation (Mbow et al. 2014). In South Africa, municipal climate adaptation plans use a sectoral approach to encourage greater interaction among different sectors and provided a clearer understanding of the needs and roles in climate adaptation (Roberts 2010). A specific case where policy implementation has been seen to influence the adaptation of technology and diversification initiatives was seen in the implementation of Global-GAP policy in the production of French beans in Kenya. The policy expected farmers to comply with certain climate adaptation strategies. The implementation supported changing crop variety, water harvesting, finding off-farm jobs, and soil conservation (Peter et al. 2017). The National Adaptation Plan 2015–2030 was developed by the Kenyan government to enhance adaptation capacity at macro-level. From the thematic perspective, Kenya's National Climate Change Action Plan (NCCAP 2018–2022) has prioritized adaptation initiatives focused on food security (GOK 2018).

### **Regional-Level Policies and Treaties**

Regional treaties and international policies affect people's mobility in the context of climate change, and environmental change is strongly influenced by different international, regional, and national policies in the fields of migration, development, and environment. The crucial importance of mobility and migration within the West African region means that subregional initiatives, treaties, and regulations are particularly significant (Hummel 2016). Economic Community of West African States (ECOWAS)'s common approach on migration enabling citizens to enter freely, reside, and settle in member countries is particularly important to livestock farmers in Senegal and Mali as one possible response to changing ecosystems (Hummel 2016).

Some regional commitments to enhance food security including the *Comprehensive Africa Agriculture Development Programme (CAADP)* and the subsequent *Malabo Declaration on Accelerated Agricultural Growth and Transformation for Shared Prosperity and Improved Livelihoods* are in place. However, the commitment to achieve the targets of the agreements may need upscaling. For example, the implementation of the agreement to allocate at least 10% of public expenditure to agriculture in Malabo Declaration remains low, with only Botswana and three other African countries including South Africa, Malawi, and Senegal engaging in public spending on agriculture worth above 10% (Mink 2016). Similarly, the implementation of the Paris Agreement to combat climate change by accelerating and intensifying climate actions remains weak with most countries making only small and cosmetic changes in transforming Intentional Nationally Determined Contributions (INDCs) to Nationally Determined Contributions (NDCs) (AFDB 2015).

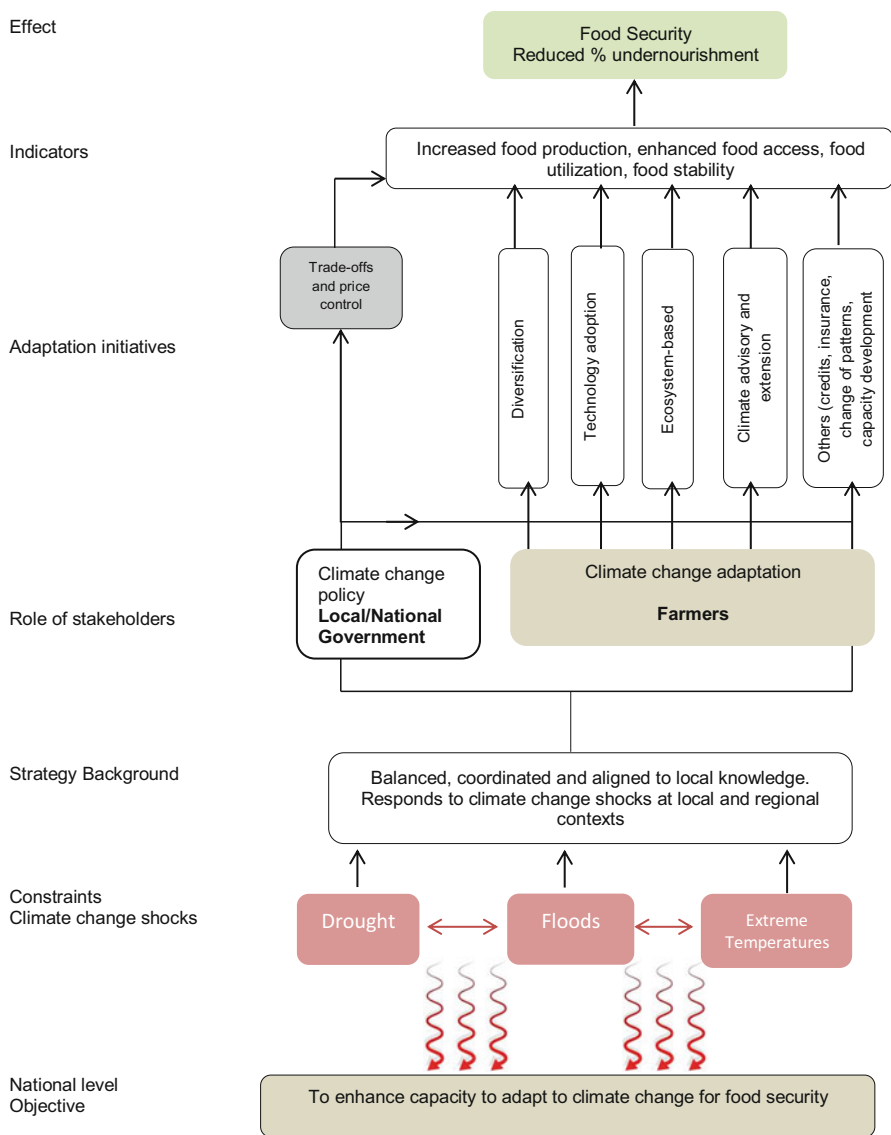
### **National-Level Policies for Technology Adoption**

Policies aligned to climate change adaptation could influence the adoption of technology. For example, Senegal Agriculture Programme was established in 2006 in response to an increase in outmigration from rural areas. This policy aimed at enhancing the use of technology in agriculture to generate sustainable incomes to attract young people to stay in their villages, enhancing rural development (Hummel 2016). Institutionalization of climate change adaptation into policy has the potential to enhance agricultural productivity. In Durban in South Africa, the climate adaptation policy ensuring that 50% of the food consumed by the rural poor is locally produced has led to the adoption of technology and diversification initiatives enhancing agricultural productivity (Roberts 2010). Policy context on climate change and agriculture in Ghana demonstrates a strong focus on the application of technology and innovation in agriculture as an engine for growth and development. Ghana's Shared Growth Development Agenda (GSGDA 2010–2013) highlighted the importance of facing climate change technological solutions such as drought-tolerant crop varieties and a transformation from rain-fed to irrigated agriculture, as well as reducing deforestation through agricultural expansion to improve the robustness of the sector to adapt to climate change (Sarpong and Anyidoho 2012). The government of Ghana has embarked on the implementation of a policy on reforestation through large-scale plantation development and small-scale on-farm regeneration activities to promote adaptation to climate change through ecosystem-based approaches. A similar initiative in reforestation has also been tried by the government of Burkina Faso (Kalame et al. 2009) and Kenya (Oloo 2013). However, there is fear that without proper planning, coordination, funding, and incentives to farmers for adoption, failure of reforestation policy could lead to large-scale deforestation and degradation, like in the case of Burkina Faso (Kalame et al. 2009).

### **Regional Policies and Trade-offs**

In Morocco, food security trade-off policies are applied at the national level. Sufficiently transparent pricing model, subsidy, import substitution (increasing domestic production and reducing imports), intensification, and subsidizing farmers to grow cereals, either through deficiency payments or targeted input subsidies, have made cereal farming more lucrative (Magnan et al. 2011). Nonetheless, countries should observe that the application of trade-off policies does not contravene World Trade Organization regulations. Mauritius is often referred to as one of the very few developing countries to have overcome poverty and hunger by participating successfully in the globalization of the world market. Application of policy that enhances sector diversification to export-oriented agricultural diversification and industrialization aimed at reducing the dependence on food imports and increasing national food self-sufficiency. The implementation of the policy led to the attainment of national self-sufficiency in potatoes (Koop 2005). Policy on the modernization of agriculture and insulation of local farmers from external competition has permitted Tunisia to substantially increase its outputs, yields, and self-sufficiency rates in products considered as being strategic, such as cereals, vegetables, oil, and livestock

products (Chemingui et al. 2001). Food self-sufficiency policy has influenced the development of irrigated farming in Botswana as a possible complement to rain-fed agriculture to enhance the production of cereals, mainly maize and sorghum (Lado 2001). The model food security pathway for African countries is summarized in Fig. 3.



**Fig. 3** A conceptual model of climate change adaptation pathway for food security in Africa. Balancing between climate change policy and adaptation (Authors own)

## Conclusion

High prevalence of undernourishment was observed in six countries, all in SSA including Chad, Liberia, Central African Republic, the Democratic Republic of the Congo, Zambia, and Zimbabwe. Countries with a high land acreage under cereal production recorded reduced undernourishment as observed in Nigeria, Sudan, Ethiopia, Tanzania, and Niger. Five countries including Niger, Eritrea, Malawi, Swaziland, and Kenya experienced extreme climate variability in the last 10 years including droughts, floods, and extreme temperatures. Despite the extreme climate variability, Niger, Eritrea, Malawi, and Swaziland still registered average to high crop production index, an indication of effective climate change adaptation. Niger demonstrated effective adaptation for food security by registering the highest crop production index in extreme climate variability. However, Kenya appears to be the most predisposed by registering both high climate variability and below average crop production index.

Diversification and technology adoption were key strategies applied across countries. However, the uptake of technology by smallholder farmers is still low across many countries in SSA. There are efforts to mainstream climate change policy in agriculture at local, national, and regional levels to enhance technology adoption, capacity building, and funding. There is a need to strengthen policy to promote climate advisory and extension, climate literacy, and capacity to use ICTs to disseminate climate information services. A lack of commitment by governments to regional agreements to enhance food security and climate action has been observed. Only Botswana, South Africa, Malawi, and Senegal had spent on agriculture worth above 10% of national expenditure in line with the *Malabo Declaration*. Similarly, the implementation of the *Paris Agreement* to combat climate change by accelerating and intensifying climate actions remains to be weak in most countries.

The chapter maps the patterns of climate variability and undernourishment prevalence and establishes the linkages between policy initiatives and adaptation actions. Future academic explorations may focus on gaps in gender perspectives in climate change adaptation and effective ICTs for the dissemination of climate information services among smallholder farmers in SSA.

**Acknowledgments** Strathmore University provided information on the call for the research. Food and Agriculture Organization of the United Nation (FAO) through the online platform provided information on food security indicators and desktop data for analysis and World Development Indicator (WDI) for Environment and Climate Change data through the online data portal.

---

## References

- Abegunde VO, Sibanda M, Obi A (2019) The dynamics of climate change adaptation in sub-Saharan Africa: a review of climate-smart agriculture among small-scale farmers. *Climate* 7:1–23. <https://doi.org/10.3390/cli7110132>
- Adjognon SG, Liverpool-Tasie LSO, Reardon TA (2017) Agricultural input credit in sub-Saharan Africa: telling myth from facts. *Food Policy* 67:93–105

- AFDB (2015) Transitioning from INDCs to NDCs in Africa. AfDB CIF knowledge series, (11/2015). Africa Development Bank Group, Abidjan
- AGRA (2014) Africa agriculture status report: climate change and smallholder agriculture in sub-Saharan Africa. AGRA, Nairobi
- Atela J, Gannon KE, Crick F (2018) Climate change adaptation among female-led micro, small and medium enterprises in semi-arid areas: a case study from Kenya working paper. In: Leal Filho W (ed) Handbook of climate change resilience. Springer, Cham, pp 1–18. [https://doi.org/10.1007/978-3-319-71025-9\\_97-1](https://doi.org/10.1007/978-3-319-71025-9_97-1)
- Belay A, Recha JW, Woldeamanuel T, Morton JF (2017) Smallholder farmers' adaptation to climate change and determinants of their adaptation decisions in the Central Rift Valley of Ethiopia. *Agric Food Secur* 6:1–13. <https://doi.org/10.1186/s40066-017-0100-1>
- Bongaarts J (2009) Human population growth and the demographic transition. *Philos Trans R Soc B Biol Sci* 364:2985–2990
- Brandt M, Rasmussen K, Peñuelas J, Tian F, Schurgers G, Verger A, Mertz O, Palmer RBJ, Fensholt R (2017) Human population growth offsets climate-driven increase in woody vegetation in sub-Saharan Africa. *Nat Ecol Evol* 1:1–6
- Burnham M, Ma Z (2016) Linking smallholder farmer climate change adaptation decisions to development. *Clim Dev* 8:289–311. <https://doi.org/10.1080/17565529.2015.1067180>
- Carr ER, Onzere SN (2018) Really effective (for 15% of the men): lessons in understanding and addressing user needs in climate services from Mali. *Clim Risk Manag* 22:82–95. <https://doi.org/10.1016/j.crm.2017.03.002>
- Cerdán CR, Rebolledo MC, Soto G, Rapidel B, Sinclair FL (2012) Local knowledge of impacts of tree cover on ecosystem services in smallholder coffee production systems. *Agric Syst* 110:119–130. <https://doi.org/10.1016/j.agsy.2012.03.014>
- Chemingui M, Chemingui MA, Thabet C (2001) Internal and external reforms in agricultural policy in Tunisia and poverty in rural area Facilitating negotiations on the Arab Customs Union View project Trade structure and performance profile for Arab countries View project Internal and External Reform. <https://www.researchgate.net/publication/229027151>
- Cobbinah PB, Anane GK (2016) Climate change adaptation in rural Ghana: indigenous perceptions and strategies. *Clim Dev* 8:169–178. <https://doi.org/10.1080/17565529.2015.1034228>
- Conceição P, Levine S, Lipton M, Warren-Rodríguez A (2016) Toward a food secure future: ensuring food security for sustainable human development in sub-Saharan Africa. *Food Policy* 60:1–9. <https://doi.org/10.1016/j.foodpol.2016.02.003>
- Crawford A, Terton A (2016) Review of current and planned adaptation action in Namibia. International Development Research Centre. <http://www.idrc.ca/carriaa>
- Crick F, Eskander SMSU, Fankhauser S, Diop M (2018) How do African SMEs respond to climate risks? Evidence from Kenya and Senegal. *World Dev* 108:157–168. <https://doi.org/10.1016/j.worlddev.2018.03.015>
- Dasgupta P, Morton JF, Dodman D, Karapinar B, Meza F, Rivera-Ferre MG, Toure Sarr A, Vincent KE (2014) Rural areas. In: Field CB, Barros VR, Dokken DJ, Mach KJ, Mastrandrea MD, Bilir TE, Chatterjee M, Ebi KL, Estrada YO, Genova RC, Girma B, Kissel ES, Levy AN, MacCracken S, Mastrandrea PR, White LL (eds) Climate change 2014: impacts, adaptation, and vulnerability. Part A: global and sectoral aspects. Contribution of working group II to the fifth assessment report of the Intergovernmental Panel on Climate Change. Cambridge University Press, Cambridge, pp 613–657
- Descheemaeker K, Oosting SJ, Homann-Kee Tui S, Masikati P, Falconnier GN, Giller KE (2016) Climate change adaptation and mitigation in smallholder crop–livestock systems in sub-Saharan Africa: a call for integrated impact assessments. *Reg Environ Chang* 16:2331–2343. <https://doi.org/10.1007/s10113-016-0957-8>
- Gitonga ZM, De Groote H, Kassie M, Tefera T (2013) Impact of metal silos on households' maize storage, storage losses and food security: an application of a propensity score matching. *Food Policy* 43:44–55
- GOK (2018) Republic of Kenya Ministry of Environment and Forestry National Climate Change action plan 2018–2022, vol I. Ministry of Environment and Forestry, Nairobi

- Hajer A, Mohsen BS, Hatem A, Hichem K, Mahouachi M, Beckers Y, Hammami H (2018) Climate change-related risks and adaptation strategies as perceived in dairy cattle farming systems in Tunisia. *Clim Risk Manag* 20:38–49. <https://doi.org/10.1016/j.crm.2018.03.004>
- He L, Tyner WE, Doukali R, Siam G (2006) Policy options to improve water allocation efficiency: analysis on Egypt and Morocco. *Water Int* 31:320–337
- Hummel D (2016) Climate change, land degradation and migration in Mali and Senegal – some policy implications. *Migr Dev* 5:211–233. <https://doi.org/10.1080/21632324.2015.1022972>
- IPCC (2007) Climate change 2007: synthesis report. In: Pachauri RK, Reisinger A (eds) Contribution of working groups I, II and III to the fourth assessment report of the intergovernmental panel on climate change [core writing team]. IPCC, Geneva, Switzerland, p 104
- IPCC (2013) Climate change 2013: the physical sciences basis. IPCC, Geneva, Switzerland
- IPCC (2018) Global warming of 1.5 °C. In IPCC – Sr15. [https://report.ipcc.ch/sr15/pdf/sr15\\_spm\\_final.pdf%0A](https://report.ipcc.ch/sr15/pdf/sr15_spm_final.pdf%0A) <http://www.ipcc.ch/report/sr15/>
- Jobbins G, Kalpakian J, Chriyaa A, Legrouiri A, El Mzouri EH (2015) To what end? Drip irrigation and the water-energy-food nexus in Morocco. *Int J Water Res Dev* 31:393–406
- Kalame FB, Nkem J, Idinoba M, Kanninen M (2009) Matching national forest policies and management practices for climate change adaptation in Burkina Faso and Ghana. *Mitig Adapt Strateg Glob Chang* 14:135–151. <https://doi.org/10.1007/s11027-008-9155-4>
- Kalungu JW, Leal Filho W (2018) Adoption of appropriate technologies among smallholder farmers in Kenya. *Clim Dev* 10:84–96. <https://doi.org/10.1080/17565529.2016.1182889>
- Keil A, Zeller M, Franzel S (2005) Improved tree fallows in smallholder maize production in Zambia: do initial testers adopt the technology? *Agrofor Syst* 64:225–236
- Khacheba R, Cherfaoui M, Hartani T, Drouiche N (2018) The nexus approach to water–energy–food security: an option for adaptation to climate change in Algeria. *Desalin Water Treat* 131:30–33. <https://doi.org/10.5004/dwt.2018.22950>
- Khalidi R, Mohamed J, Khalidi G (2012) Impacts of climate change on the small ruminants farming systems in northwestern Tunisia and adaptation tools. In: New approaches for grassland research in a context of climate and socio-economic changes. CIHEAM, Zaragoza, pp 427–431
- Kimaro AA, Timmer VR, Chamshama SAO, Mugasha AG, Kimaro DA (2008) Differential response to tree fallows in rotational woodlot systems in semi-arid Tanzania: post-fallow maize yield, nutrient uptake, and soil nutrients. *Agric Ecosyst Environ* 125:73–83
- Kiptot E, Franzel S, Degrande A (2014) Gender, agroforestry and food security in Africa. *Curr Opin Environ Sustain* 6:104–109. <https://doi.org/10.1016/j.cosust.2013.10.019>
- Kmoch L, Pagella T, Palm M, Sinclair F (2018) Using local agroecological knowledge in climate change adaptation: a study of tree-based options in northern Morocco. *Sustainability (Switzerland)* 10:3719. <https://doi.org/10.3390/su10103719>
- Koop K (2005) Food security in the era of globalisation-the case of Mauritius 49 governance and food security in the era of globalization: the case of Mauritius, vol II. <https://halshs.archives-ouvertes.fr/halshs-00265114>
- Kuntashula E, Chabala LM, Mulenga BP (2014) Impact of minimum tillage and crop rotation as climate change adaptation strategies on farmer welfare in smallholder farming systems of Zambia. *J Sustain Dev* 7:95–110. <https://doi.org/10.5539/jsd.v7n4p95>
- Lado C (2001) Environmental and socio-economic factors behind food security policy strategies in Botswana. *Dev South Afr* 18:141–168. <https://doi.org/10.1080/03768350120041875>
- Lasco RD, Delfino RJP, Catacutan DC, Simelton ES, Wilson DM (2014) Climate risk adaptation by smallholder farmers: the roles of trees and agroforestry. *Curr Opin Environ Sustain* 6:83–88. <https://doi.org/10.1016/j.cosust.2013.11.013>
- Luximon Y, Nowbuth MD (2010) A status of food security in Mauritius in face of climate change. *Eur Water* 32:3–14
- Magnan N, Lybbert TJ, McCalla AF, Lampietti JA (2011) Modeling the limitations and implicit costs of cereal self-sufficiency: the case of Morocco. *Food Secur* 3:49–60. <https://doi.org/10.1007/s12571-010-0103-2>

- Mbow C, Van Noordwijk M, Luedeling E, Neufeldt H, Minang PA, Kowero G (2014) Agroforestry solutions to address food security and climate change challenges in Africa. *Curr Opin Environ Sustain* 6:61–67. <https://doi.org/10.1016/j.cosust.2013.10.014>
- Mink SD (2016) Findings across agricultural public expenditure reviews in African countries, vol 1522. International Food Policy Research Institute, Washington, DC
- Mutunga EJ, Ndungu CK, Muendo P (2017) Smallholder farmers perceptions and adaptations to climate change and variability in Kitui County, Kenya. *J Earth Sci Clim Change* 8(3). <https://doi.org/10.4172/2157-7617.1000389>
- Namirembe S, Leimona B, Van Noordwijk M, Bernard F, Bacwayo KE (2014) Co-investment paradigms as alternatives to payments for tree-based ecosystem services in Africa. *Curr Opin Environ Sustain* 6:89–97. <https://doi.org/10.1016/j.cosust.2013.10.016>
- Ntukamazina N, Onwonga RN, Sommer R, Rubyogo JC, Mukankusi CM, Mburu J, Kariuki R (2017) Index-based agricultural insurance products: challenges, opportunities and prospects for uptake in sub-Saharan Africa. *J Agric Rural Dev Trop Subtrop* 118(2):171–185
- Nyasimi M, Amwata D, Hove L, Kinyangi J, Wamukoya G (2014) Evidence of impact: climate-smart agriculture in Africa. <http://www.ccafs.cgiar.org>
- Oloo G (2013) Evaluation of climate change adaptation strategies and their effect on food production among smallholder farmers in Bungoma County, Kenya. Egerton
- Osabohien R, Afolabi A, Godwin A (2018) An econometric analysis of food security and agricultural credit facilities in Nigeria. *Open Agric J* 12(1):227–239
- Peter SO, Chris AO, John M, Rose AN (2017) Effect of global-GAP policy on smallholder French beans farmers climate change adaptation strategies in Kenya. *Afr J Agric Res* 12:577–587. <https://doi.org/10.5897/ajar2017.12149>
- R Core Team (2020) R: a language and environment for statistical computing. R Foundation for Statistical Computing, Vienna, Austria
- Roberts D (2010) Prioritizing climate change adaptation and local level resilience in Durban, South Africa. *Environ Urban* 22:397–413. <https://doi.org/10.1177/0956247810379948>
- Sarpong DB, Anyidoho NA (2012) Climate change and agricultural policy processes in Ghana. <http://www.future-agricultures.org>
- Serdaczny O, Adams S, Baarsch F, Coumou D, Robinson A, Hare W, Schaeffer M, Perrette M, Reinhardt J (2016) Climate change impacts in sub-Saharan Africa: from physical changes to their social repercussions. *Reg Environ Chang* 17:1585–1600
- Silvestri S, Sabine D, Patti K, Wiebke F, Maren R, Ianetta M, Carlos QF, Mario H, Anthony N, Nicolas N, Joash M, Lieven C, Rufino MC (2015) Households and food security: lessons from food secure households in East Africa. *Agric Food Secur* 4:23. <https://doi.org/10.1186/s40066-015-0042-4>
- Singh C, Urquhart P, Kituyi E (2016) From pilots to systems: barriers and enablers to scaling up the use of climate information services in smallholder farming communities. CARIAA working paper no. 3. International Development Research Centre, Ottawa/London. <http://www.idrc.ca/cariaa>
- Spires M, Shackleton S, Cundill G (2014) Barriers to implementing planned community-based adaptation in developing countries: a systematic literature review. *Clim Dev* 6:277–287. <https://doi.org/10.1080/17565529.2014.886995>
- Tefera T, Kanampiu F, De Groote H, Hellin J, Mugo S, Kimenju S, Beyene Y, Boddupalli PM, Shiferaw B, Banziger M (2011) The metal silo: an effective grain storage technology for reducing post-harvest insect and pathogen losses in maize while improving smallholder farmers' food security in developing countries. *Crop Prot* 30:240–245
- UNFCCC (2006) Technologies for adaptation to climate change. Climate Change Secretariat (UNFCCC), Bonn, Germany
- Vignola R, Harvey CA, Bautista-Solis P, Avelino J, Rapidel B, Donatti C, Martinez R (2015) Ecosystem-based adaptation for smallholder farmers: definitions, opportunities and constraints. *Agric Ecosyst Environ* 211:126–132. <https://doi.org/10.1016/j.agee.2015.05.013>



- Wood SA, Jina AS, Jain M, Kristjanson P, DeFries RS (2014) Smallholder farmer cropping decisions related to climate variability across multiple regions. *Glob Environ Chang* 25:163–172. <https://doi.org/10.1016/j.gloenvcha.2013.12.011>
- Woyessa YE, Bennie ATP (2007) Tillage-crop residue management and rainfall-runoff relationships for the Alemaya catchment in Eastern Ethiopia. *Sh Afr J Plant Soil* 24:8–15

**Open Access** This chapter is licensed under the terms of the Creative Commons Attribution 4.0 International License (<http://creativecommons.org/licenses/by/4.0/>), which permits use, sharing, adaptation, distribution and reproduction in any medium or format, as long as you give appropriate credit to the original author(s) and the source, provide a link to the Creative Commons license and indicate if changes were made.

The images or other third party material in this chapter are included in the chapter's Creative Commons license, unless indicated otherwise in a credit line to the material. If material is not included in the chapter's Creative Commons license and your intended use is not permitted by statutory regulation or exceeds the permitted use, you will need to obtain permission directly from the copyright holder.





# Gender Implications of Farmers' Indigenous Climate Change Adaptation Strategies Along Agriculture Value Chain in Nigeria 89

Olanike F. Deji

## Contents

Introduction .....	1812
The Objectives .....	1815
The Theoretical Framework: Gender Response Theory (GRT) .....	1815
Agriculture Value Chain (AVC) .....	1817
Gendered Dimensions of Climate Change Impacts Along AVC .....	1818
Factors Influencing the Vulnerability of Agriculture in Nigeria to Climate Change Impacts .....	1821
Gendered Indigenous Climate Change Adaptation Strategies Along Agriculture Value Chain .....	1822
The Indigenous and Expert-Based Artificial Adaptation Strategies .....	1823
Gendered Indigenous Adaptation Strategies to Climate Change/Variability .....	1826
Indigenous Early Warning Meteorological Adaptation Strategies .....	1829
Gender Implications of the Indigenous Climate Change Adaptation Strategies .....	1829
Conclusions .....	1830
Recommendations .....	1832
References .....	1832

## Abstract

Climate change contributes significantly to the looming food insecurity in the rain-fed agricultural countries of Africa, including Nigeria. There is a gender dimension in climate change impacts and adaptation strategies along Agriculture

---

This chapter was previously published non-open access with exclusive rights reserved by the Publisher. It has been changed retrospectively to open access under a CC BY 4.0 license and the copyright holder is "The Author(s)". For further details, please see the license information at the end of the chapter.

---

O. F. Deji (✉)  
Obafemi Awolowo University, Ile Ife, Nigeria  
e-mail: [dejiolanike@yahoo.de](mailto:dejiolanike@yahoo.de)

Value Chain (AVC) in Nigeria. The chapter gender analyzed the aspects of climate change impacts; identified the indigenous and expert-based artificial adaptation strategies; assessed the gender differences in the adaptation strategies; and provided the gender implications of the indigenous adaptation strategies among actors along the AVC. The chapter adopted a value chain-based exploratory design with gender analysis as the narrative framework with Gender Response Theory as the theoretical background. There were gender differences in the production, economic, and social dimensions of the climate change impacts along the AVC. The indigenous climate change adaptation strategies were availability, low cost, and easily accessible; hence they were popularly adopted by male and female AVC actors. The adopted indigenous adaptation strategies challenged the social relations, influenced reordering of social and gender relations, participation, and power relation among the male and female actors along the AVC.

---

**Keywords**

Gender · Farmers · Indigenous · Climate change · Adaptation strategies · Gender Response Theory · Agriculture Value Chain

---

## Introduction

Food security influences agricultural production security. However, the diversion of government attention and political will from agriculture to the oil economy marked the beginning of food insecurity in Nigeria. While the population continues to increase, food production is decreasing at an alarming rate. Agriculture is a significant sector that impacts the socioeconomic livelihoods of the majority of the people of Nigeria, because it is the primary source of livelihoods for the majority. Unlike the oil booms that give direct benefits to a few minorities, Nigeria possesses a pro-agriculture environment and climate. Until the discovery of the oil boom in Nigeria, which marks the sharp diversion of the economic and political attention of the government away from agriculture to the oil boom, Nigeria was food sufficient and a significant exporter of most significant crops in Nigeria. The gap between the rich and the poor is widening as the benefits from oil booms increases, and agricultural production decreases.

Downie (2017) identified uncompetitive environment for agribusiness, inadequate input supply, poor market access, poor access to credit, lukewarm political commitment, and neglected agricultural research system as the obstacles to agricultural development in Nigeria. However, global warming-induced climate change and variability are worsening the situation. Ground-based observations and satellite data from the United States National Aeronautics and Space Administration (NASA) revealed that the first 6 months of 2016 were the warmest 6-month period since 1880 when records of temperatures begin (NASA 2016). The two major ice sheets are melting much faster relative to the past decades (Intergovernmental Panel on Climate

Change-IPCC 2014). During 2003–2013, disasters cost nearly US\$1.5 trillion in global economic damage (Food and Agriculture Organization-FAO 2015).

The impacts of climate change and variability on agriculture is higher in the rain-fed agricultural nations such as Nigeria. Climate change is a significant push factor in agriculture in Nigeria due to the resultant irregular rainfall pattern and temperature swings resulting from climate change impacting agricultural production negatively along the value chain (Christopher and Jonathan 2011; Apata 2013; Acosta et al. 2015).

The impacts of climate change along the Agriculture Value Chain (AVC) have gender differences. Gender roles and gendered access and control over resources influence the gender difference in the vulnerability to climate change impacts by the male and female actors. The female gender is the most disadvantaged in terms of access to and control over resources, participation and contribution to decision-making at all levels, which makes them deficient in asset base; hence they are highly vulnerable to disasters such as from climate change and variability (FAO 2013; Gutierrez-Montes et al. 2018). This chapter explains the theory underpinning responses (adaptation/mitigation) of male and female AVC actors to the stimuli from climate change and variability.

Literatures (FAO 2011; Okali 2012; IPCC 2014; UNDP 2014) revealed that factors enhancing females' high vulnerability to the effects of climate change and variability are: (i) low adaptive capacity; (ii) fewer endowment and entitlements than men; (iii) unequal survival opportunities (for instance, limitations in mobility/migration); (iv) low decision-making potentials; and (v) inadequate access to and control over critical resources.

Kolawole et al. (2014) and Williams et al. (2019) affirm that the majority of farmers in Africa are smallholders and depend on local instead of scientific meteorology information for their adaptation to climate change and variability. Weather forecasting and early warning information to reduce vulnerability to climate change and variability are not readily available to farmers, are mostly written in technical jargons not smoothly comprehensive to local farmers, and are usually expensive to access (Raymond et al. 2010; Kolawole et al. 2014; Myuri et al. 2017). Scientific meteorology information requires technical skills to understand and adopt. Indigenous meteorology information is acquired through experiences and socialization by the parents and elders. According to Kolawole et al. (2014), both local and scientific meteorology information are products of observation, experimentation, and validation. However, scientific meteorologist adopts systematic procedure, while the process for the local one is unregulated, unorganized, and limited; hence the later may be less accurate and valid but could serve as stepping stone to the former. The local meteorology information could be useful in establishing a local weather experimental station to enhance farmers' access to the information for improved adaptation to climate change impacts.

Projects centered around the climate-smart agriculture (CSA) approach usually promote the adoption of technologies, as well as practices and services aimed at increasing agricultural productivity while enhancing producers' climate adaptation and mitigation capacities (Louman et al. 2015; Williams et al. 2019).

According to Gutierrez-Montes et al. (2018), if women have equal access to such technologies and practices and take ownership over the resulting benefits, Climate Smart Agriculture (CSA) may have a more significant effect on family well-being. To better understand the relationship between CSA, gender, and rural livelihoods, there is a need for well-defined and efficient indicators (SMART indicators) that allow project managers and policy-makers to assess and evaluate CSA programs or interventions in terms of their impact on gender relations (Gutierrez-Montes et al. 2018)

Women are known to be more involved in agricultural activities than men in sub-Saharan African (SSA) countries, Nigeria inclusive with as much as 73% involved in cash and food crops, arable and vegetable gardening, 16% in postharvest activities, and 15% in agroforestry (FAO and ECOWAS 2018; FAO 2019). The percentage of work done by women farmers far outweighs that of men, especially in Nigeria; they are major stakeholders for sustainable development (Faniyi et al. 2018, 2019; FAO 2019; National Bureau of Statistics-NBS 2016). There is gender role differentiation of immense dimension within African agriculture. Women make a significant contribution to food production and processing, but men seem to take more of the farm decisions and control the productive resources (Anaglo et al. 2013; Eger et al. 2018).

Nigeria accounts for nearly 20% of continental GDP and about 75% of the West Africa economy; despite this dominance, its exports to rest of Africa was at 12.7%, and only 3.7% of total trade is within the Economic Community of West African States (FAO and ECOWAS 2018; Aduwo et al. 2019). Despite the prominence of oil in the country's economic wealth, agriculture still contributes significantly to the Nigerian economy. The country's agriculture sector provides direct employment for about 75% of the population (NBS 2016; Alao et al. 2014). In the 1970s and 1980s, agriculture contributed nearly two-thirds of Nigeria's GDP. Currently, it provides about 40.2%, employs approximately 70% (males and females) of the labor force, accounts for more than 70% of non-oil exports and, most importantly, provides over 80% of the country's food needs (FAO 2010; FAO and ECOWAS 2018). With a population of over 180 million and still growing, agricultural development is vital for the attainment of food security and sustainable development in Nigeria.

Women farmers in rural areas are the majority of the agricultural workforce and should be empowered and provided free access to resources and participation in decision-making and programs (Bayeh 2016).

Women constitute a significant part of the agricultural labor force, and their contribution is essential to the success of the Economic Recovery and Growth Plan (ERGP) in the Federal Republic of Nigeria (FAO 2019; Faniyi et al. 2018). Although Women's roles are evident along the Agriculture Value Chain, the economic reward is not commensurate; they are not adequately benefiting from agricultural policies, programs, and budgets.

United Nations Development Program (UNDP 2014) report revealed that in Nigeria, women play a dominant role in agricultural production where they make up some 60–80% of the farm labor force, depending on the region, and they produce two-thirds of the food crops. Yet, the female farmers are among the voiceless, especially concerning influencing agricultural policies, programs, and development.

In Nigeria, a wide gender gap exists, and women in agriculture are worse for it (Aduwo et al. 2019). Nigeria agriculture is a rural community based, and 70% of the poor in Nigeria are in the rural areas, 59% of the poor household heads have women as heads (FAO 2011, 2013). Women constitute 70% of agricultural labor force; 60–70% of food crop producers; approximately 100% of food processors; 80% of food storage and transportation from farm gate to village market; 90% of hoeing and weeding work in farms; and 60% of harvesting and marketing services (Christopher and Jonathan 2011; Apata 2013). Despite the significant position of women in agriculture, men make major farm decisions and have access to land. Most women do not have the right to landed property, are denied access to credit and relevant capacity building opportunities, information, and participation (Anaglo et al. 2013; Eger et al. 2018).

## The Objectives

Specifically, the chapter:

- (i) Gender analyzed the dimensions of climate change impacts
- (ii) Identified the indigenous and expert-based artificial adaptation strategies
- (iii) Assessed the gender differences in the adaptation strategies
- (iv) Provided the gender implications of the indigenous adaptation strategies among actors along the Agriculture Value Chain (AVC)

---

## The Theoretical Framework: Gender Response Theory (GRT)

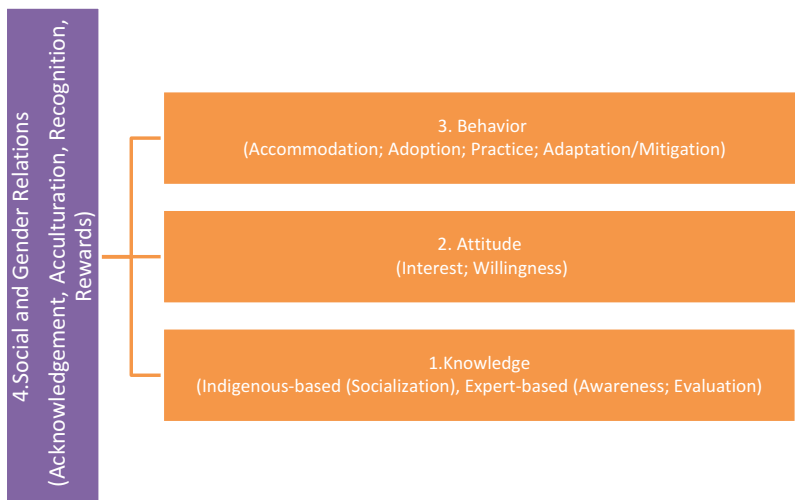
Gender Response Theory – GRT propounded by Deji (2019) is the adopted theory in this chapter. Gender Response Theory states that males respond to stimuli (push or pull factor) by substitution while females respond by addition. And that male's response is usually more prompt than the female's, based on higher economic and social potentials.

Pull factors include positive and attractive forces such as new technology/innovation/idea/knowledge, to mention a few. Push factors include negative/repelling/adverse situations or circumstances such as climate change/variability, conflicts, poverty, ill-health, natural disaster, to mention a few.

GRT propound that usually male will respond to stimuli by substitution (replacing the old with the new). In contrast, females will often respond by addition (building on the existing local conventional or currently adopted knowledge/innovation/technology, to mention a few).

GRT was proven at four main levels of response, namely:

- (i) Knowledge (indigenous and expert-based) – socialization, awareness, evaluation
- (ii) Attitude (cognitive, affective) – interest, willingness



**Fig. 1** Operational model of Gender Response Theory – GRT (Deji 2019)

- (iii) Behavior (utilization of the knowledge as improvement or defensive/risk aversion strategy) – accommodation, adoption, practice, and adaptation/mitigation
- (iv) Social and gender relations (responsibility, role, participation, engagement, decision-making, agency) – acknowledgment, acculturation, recognition, rewards (Fig. 1).

GRT confirms gender differences in the human response to stimuli (pull or push factor). The theory affirms that: the indigenous knowledge is a common asset to both male and female; males are likely to substitute their indigenous knowledge for new/modern/scientific/expert-based knowledge, while the females are likely to add the new knowledge to the indigenous knowledge; males are likely to respond to new knowledge/innovation/technology more promptly than the females; and that the economic and social relation potentials, especially the decision-making power, influence the promptness of the male's response to (adoption of) the new knowledge/innovation/technology, to mention a few.

Climate change is a push factor in agriculture, with significant impacts on rain-fed agriculture that characterizes most developing nations like Nigeria. Male and female are involved in activities along the AVC; climate change has implications along the AVC and may have gender dimensions as pounded by the Gender Response Theory. Logically, the male and female AVC actors will respond to climate change/variability impacts more or less differently. Hence, GRT is the adopted theoretical framework for this chapter.

The following narrative sections in this chapter are textual, qualitative, and secondary data, originated from field experience and literature through rigorously digested knowledge and established information from the author's field experience of over 20 years, covering all the ecological regions in Nigeria.

### Agriculture Value Chain (AVC)

Agriculture Value Chain comprises interrelated activities and actors at different nodes from the point of decision and sourcing for inputs to the final stage when the agricultural product is processed, distributed, and consumed by the end users. The value chain in this chapter focused on crop cultivation (Fig. 2). Although the content of the activities may vary within different agricultural crop enterprises, they have many similarities.

1. Inputs: Includes finance, land, labor, tools and machines, seeds and seedlings and plant cuttings, chemicals, membership of agricultural associations and networks, extension and advisory services, training on required knowledge and skills, to mention a few. Required activities are sourcing, acquisition, transportation, storage, repair and maintenance, participation, to mention a few.
2. Land preparation: Includes activities such as land clearing, harrowing, landscaping, ridging, nursery bed construction, laying of irrigation pumps, to mention a few.
3. Planting: Planting/sowing, transplanting, grafting, budding, to mention a few.
4. Cultivation: Includes activities to enhance the germination and growth of the planted materials. It includes weeding, thinning, supplanting, staking, mulching, wetting and irrigation, fertilizer, and chemical applications, pest controls, transportation, to mention a few.

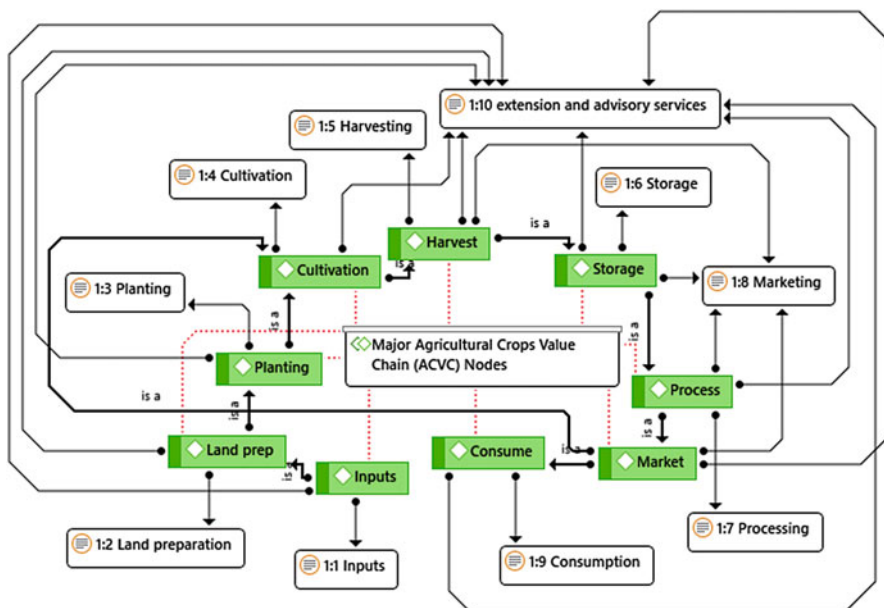


Fig. 2 Agriculture Value Chain (AVC) – Crops (Source: Deji 2019)



5. Harvesting: Harvesting, packing, transportation, marketing, consumption, to mention a few.
6. Storage: Packing, loading, transportation, application of preservatives, cleaning, and preservation, to mention a few.
7. Processing: Transportation, conventional processing, value-addition, packaging, labeling, to mention a few.
8. Marketing: Transportation, packaging, selling, buying, record keeping, savings, advertisement, to mention a few.
9. Consumption: Purchasing, transportation, preparation, cooking, value addition, packaging, distribution, storage, to mention a few.

### **Gendered Dimensions of Climate Change Impacts Along AVC**

Figure 3 shows the significant indicators of climate change and variability as experienced in Nigeria, such as irregular rainfall pattern and quantity; fluctuation in temperature; and increase in wind and storm intensity. Furthermore, Fig. 1 indicates the primary and secondary impacts of climate change and variability. The significant consequences include decrease in rainfall/water shortage; irregular temperature fluctuation; dry weather; decline in soil moisture and fertility; an increase in drought incidence; and a rise in flood incidence.

The secondary impacts have two dimensions along the AVC, such as (1) production and economical and (2) social and gender relations. The dimension of production and economical includes inappropriate planting periods; low and poor yields; loss of species; decrease in agro-biodiversity; increase in epidemics; and increase in postharvest losses. The social and gender relation impacts dimension encompasses the reordering in social and gender roles and relations along the AVC.

Figure 4 shows the significant impacts of climate change indicators such as irregular rainfall pattern and quantity, flooding, rise in temperature, and wind storms at each of the seven nodes along the AVC.

1. Input node (access and utilization): Climate change impacts are: scarcity of some inputs such as fertilizer due to the high rate of damages done by heavy rainfall and high temperature. Poor quality of some inputs such as seedlings due to temperature and rainfall fluctuations; increase in the cost of production arising from spending more money and time; and high rate of damages/breakdown and difficulty in using farm machinery.
2. Land preparation: Major climate change impacts include unfavorable soil moisture and texture; loss of topsoil; increase in frequency of land preparation activities such as plowing and harrowing due to an increase in the rate of weed growths; and increase in cost.
3. Planting: Unpredictable planting time resulting to early and delay planting; repeated planting and thinning; utilization of more planting materials and resources like time, money, and labor; increase in wastages of resources like time, money, and labor; and higher pressure on the land leading to soil hardening and loss of fertility.

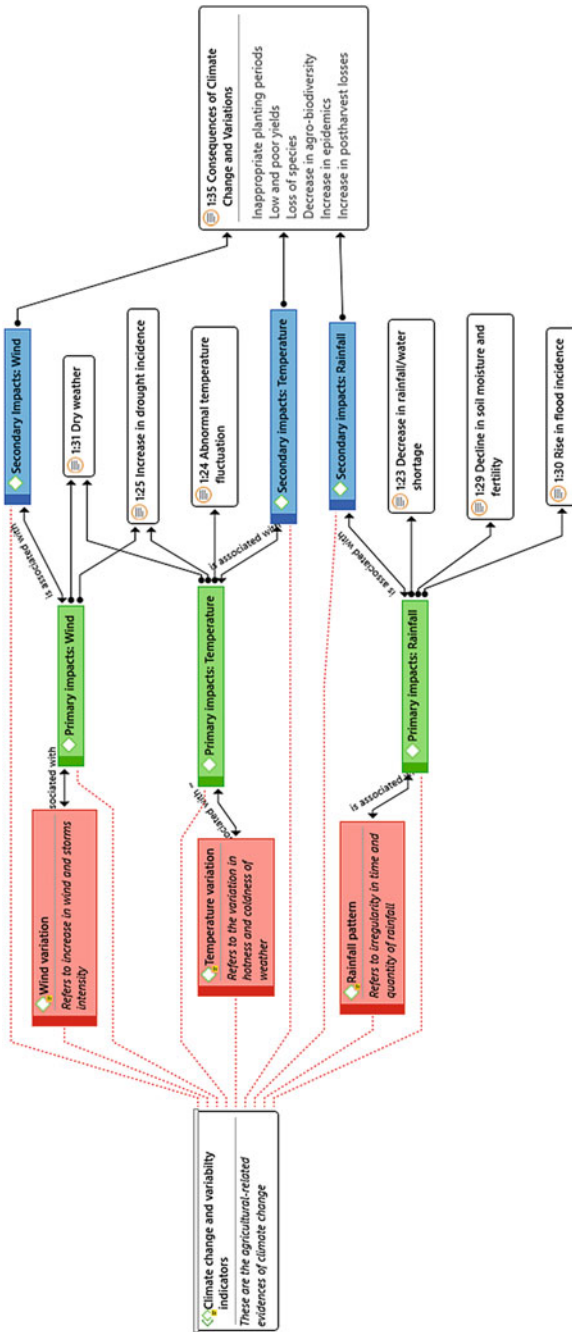


Fig. 3 Climate change and variability indicators. (Source: Deji 2019)

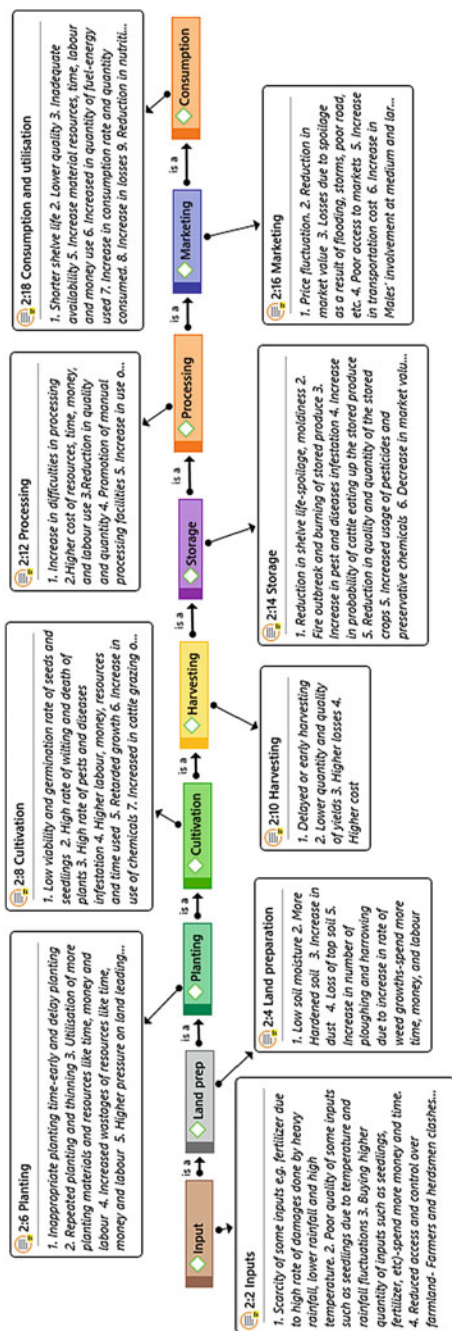


Fig. 4 Climate change impacts along Agriculture Value Chain (Source: Deji 2019)

4. Cultivation: Climate change influences low viability and germination rate of seeds and seedlings; plant growth retardation; high rate of wilting and death of plants; high rate of pests and diseases infestation; higher cost in forms of labor, money, resources, and time used; increase in use of chemicals; and increase in cattle grazing on the crops/farmland.
5. Harvesting: Climate change influences delayed or early harvesting, lower quantity and quality of yields; higher losses; and higher cost of harvesting.
6. Storage: Climate change significantly contributes to the reduction in shelf life of farm produce. It contributes to increased fire incidence and burning of stored produce, increase in pest and disease infestation, increase in the probability of cattle eating up the stored produce, and reduction in quality and quantity of the stored farm produce. It enhances the usage of pesticides and preservative chemicals; and decrease in nutrient and market value.
7. Processing: There is an increase in difficulties in processing farm produce; higher cost; reduction in quality and quantity of finished farm products; and promotion of manual processing facilities. It increases the use of preservatives and other chemicals.
8. Marketing: There is an increase in price fluctuation; reduction in market value; loss; poor access to markets; increase in transportation and other costs; increase in males' involvement at medium and large-scale marketing.
9. Consumption and utilization: At the household level, climate change influences shorter shelf life. It enhances low quality, inadequate availability of food materials; increase in cost of food preparation and readiness; increase in consumption rate and quantity consumed; increase in losses; and reduction in nutritional benefits, meal/food security.

### **Factors Influencing the Vulnerability of Agriculture in Nigeria to Climate Change Impacts**

- (i) Rain-fed agriculture
- (ii) Subsistence farming
- (iii) Gendered division of labor and access to resources
- (iv) Lack or inadequate social insurance for farmers
- (v) Unfavorable gender norms against women who are the major workforce
- (vi) Patriarchal culture: practiced as males' domain
- (vii) No formal insurance plan for farmers
- (viii) Small scale and low literate by majority
- (ix) Low awareness of the agriculture-based sources of greenhouse gases (GHG) among the farmers
- (x) Limited modern effective adaptive and mitigation capability
- (xi) Limited access to scientific meteorological information and technologies
- (xii) Inadequate political will and enabling environment for climate smart agriculture

## Gendered Indigenous Climate Change Adaptation Strategies Along Agriculture Value Chain

Climate change and variability impact are not gender neutral; they affect both males and females differently. There are complex and dynamic links between climate change and gender in terms of vulnerability to the adverse impacts of climate change and adaptation to climate change. Within countries, vulnerability to climate change impacts links to poverty and economic marginalization (UNDP 2014).

Adaptation is a process by which individuals, families, communities, and countries minimize the negative impacts of climate change and variability on their socioeconomic livelihoods. It means the strategies or methods adopted in coping with the threats resulting from the unavoidable climate change and variability impacts. On the other hand, mitigation means actions, practices, steps taking or adopted to reduce the greenhouse gases (GHG) in order to minimize their effects on global warming.

Indigenous adaptation strategies are the traditional conservative knowledge, experience, and practices that are products of repeated activities, communicated from parents and elders to younger ones through the socialization process, adopted as coping strategies to reduce the vulnerability and impacts of climate change. Indigenous adaptation strategies for alleviating the climate change impacts on agriculture and AVC actors' livelihood varied basically on the gender roles (direct and indirect) along the AVC. Indigenous adaptation and mitigation strategies are products of the repeated process of informal *observation, trial, experimentation, and validation*, which naturally promotes/popularizes the indigenous knowledge, experiences, and practices over time.

Roles are responsibilities carried out or performed by the primary or secondary owner of the responsibility. Gender roles are activities carried out or performed by an individual based on his/her sex as constructed by the norms and values of the society.

The concept of gender roles is significant and most applicable in agriculture discipline, because it helps to understand that some activities are carried out by individuals outside the assigned responsibilities as constructed in the norms and values of the society (Figs. 4a–e). Direct gender role refers to the activity personally carried out by an individual based on his/her sex as determined by the norms and values of the society. Indirect gender roles are activities carried out by a male or female (paid or free of charge) on behalf of another person, which may not necessarily be according to the norms and values about gender roles in the society.

Climate change significantly influences gender roles along the AVC (Figs. 5a–e). As a response to the negative impacts of the climate change on agriculture productivity along the value chain and the general livelihoods of the farm household, there are observed dynamics of roles between the male and female AVC actors. Such gender role dynamics include role delegation, role diversification, role commodification, and role intensification.

The dominant indigenous adaptation strategies among the AVC actors in Nigeria are as follows:

1. **Preproduction phase:** Bulk purchase of inputs at the group level, bush fallowing, zero tillage, fragmented planting, late and early planting, and land intensification
2. **Production phase:** Mulching, thinning, supplanting, manual irrigation, nursery and transplanting, organic fertilizer and micro-dozing application, staking, use of local herbs, mixed cropping, multi-cropping, crop rotation, mixed farming, dry season farming, traditional greenhouse farming, crop diversification, varying planting dates, increase in irrigation, soil and water conservation techniques, shading and shelter, and shortening the length of the growing season
3. **Harvesting phase:** Early/late harvesting, fragmented/installment/selected harvesting, on-farm sales of fresh crops, harvesting fresh
4. **Storage:** Air drying, sun drying, heat drying, e.g., over kitchen roofs, application of pepper, storage under the roof, over the kitchen, in gourds, earthen pots, storing below room temperature overnight on the roof, to mention a few
5. **Processing:** Value addition, repackaging to enhance economic value, group purchase of materials
6. **Marketing:** Online marketing, e.g., mobile phone, group-marketing of produce, value-addition, selling on the farm and at the farm gate, direct sales to bigger companies and consumers
7. **Consumption:** Avoiding bulk purchase, cooking what can be consumed at once, storage of used water for other purposes

## The Indigenous and Expert-Based Artificial Adaptation Strategies

Male and female farmers and other value chain actors acquired indigenous adaptation and mitigation intelligence/strategies through experiences and socialization. The indigenous intelligence/strategies are popular local knowledge asset bases among the African AVC actors because they are available, cheap, and simple to understand and practice with limited gender discrimination. The indigenous adaptation intelligence/strategies are products of informal, unregulated observations, experimentations, and validation.

The indigenous knowledge/intelligence/strategy is different from the expert-based human intelligence (e.g., through extension agency) and the artificial intelligence (human-embedded machine intelligence). The indigenous knowledge/intelligence/strategy is not regulated, lacks accuracy, hence not usually efficient and effective.

There was low awareness and adoption of expert-based/artificial intelligence-based climate-smart agricultural/adaptation strategies. It may be due to their inherent low cultural compatibility, high cost, inadequate availability, gender limitation, and complexity that require high technicality and competence.

The indigenous adaptation strategies have the potentials to provide an enabling environment that could enhance the popularity and adoption of artificial intelligence



Fig. 5 (continued)

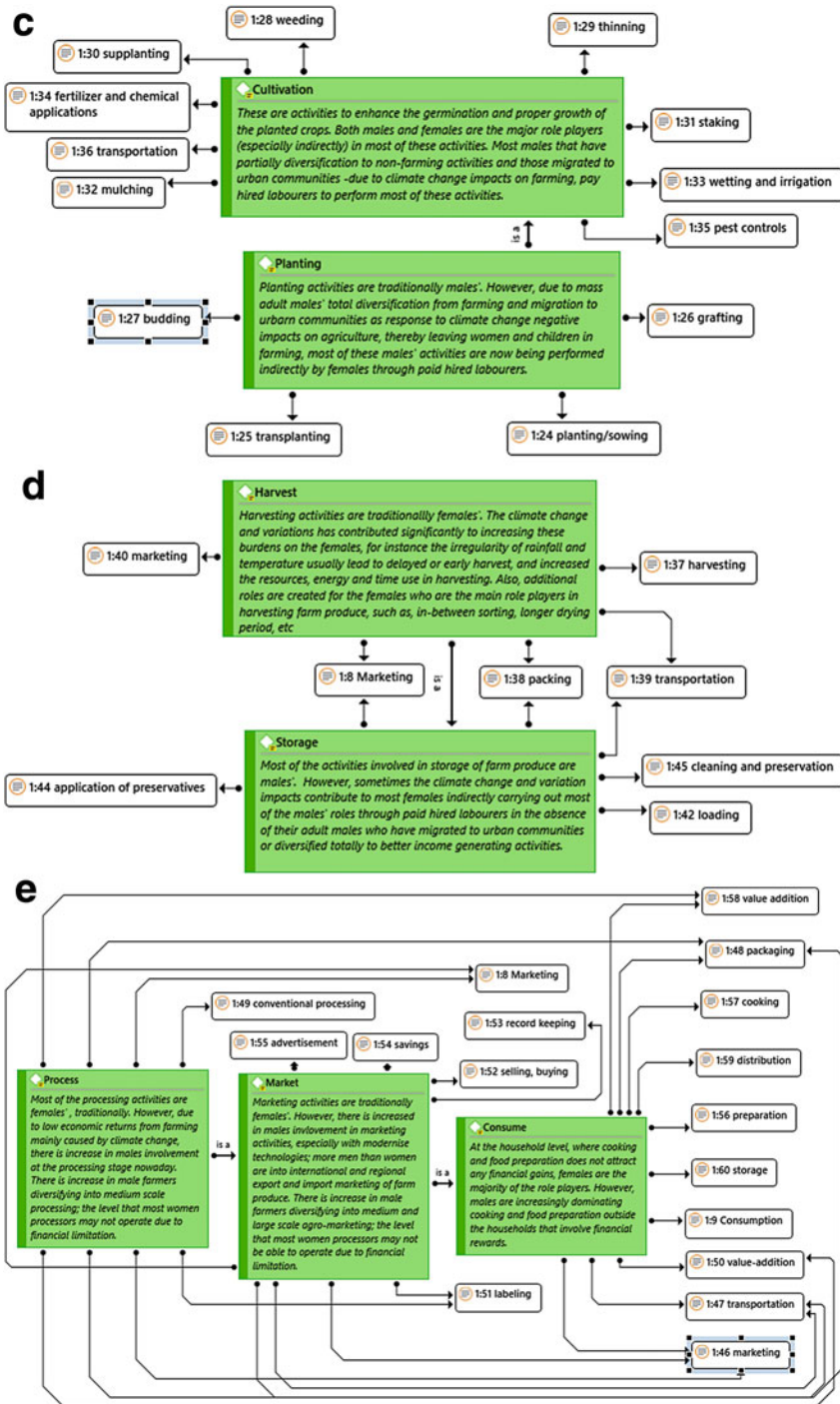


Fig. 5 (continued)



(AI) if adequately integrated. However, adequate integration will require an interdisciplinary scientific reinvention process that engaged both male and female AVC actors and the extension professionals (expert-based human intelligence).

## Gendered Indigenous Adaptation Strategies to Climate Change/ Variability

The popular indigenous adaptation strategies among Nigerian male and female AVC actors are in two categories: (i) resource-based indigenous adaptation strategies and (ii) relation-based indigenous adaptation strategies. Resource-based indigenous adaptation strategies target the factors of production-related adaptation strategies, such as land, finance, labor, and time (Fig. 5). The relation-based adaptation strategies focus on social capital and relations. The resource-based and relation-based indigenous adaptation strategies are:

1. **Land:** *Land fragmentation* for multi-cropping and mixed farming; *land commodification*: sales of farmland for money; *land intensification*: repeated cultivation on farmland leading to shorter fallow period; intensive practice of *inorganic soil fertilization and conservation* methods; and *land use diversification*: using the farmland for nonagricultural income-generating activities.
2. **Finance:** *Financial diversification*: investing financial resources in other income-generating activities such as farming and nonfarming activities; *multiple sources of finance*: to increase financial stability and security; increase in *contract farming*: an organization supplied farmers all essential inputs to produce certain crops that will be purchased in kinds by the organization; and *community-based cooperative or group saving, credit, and loan system*.
3. **Labor:** *Migration* of nondisabled males (spatially migrating from farming communities to urban cities in search of alternative sources of income, or livelihood-wise migration to other jobs, especially, nonagricultural income activities); *use of family and child labor*; *livelihood diversification* to other activities along AVC (for example, a crop farmer diversifying into retailing/marketing of farm produce) or to nonfarming activities; and increase in use of *hired labor*, especially to carry out strenuous and abandoned agricultural activities.
4. **Soil conservation management practices:** Most of the indigenous soil conservation management measures are both adaptive and mitigating in nature, e.g.,



**Fig. 5** (a) Climate change impacts on gender roles along Agricultural Value Chain – input node. (Source: Deji 2019). (b) Climate change impacts on gender roles along Agricultural Value Chain – land preparation node. (Source: Deji 2019). (c) Climate change impacts on gender roles along Agricultural Value Chain – planting and cultivation nodes. (Source: Deji 2019). (d) Climate change impacts on gender roles along Agricultural Value Chain – harvesting and storage nodes. (Source: Deji 2019). (e) Climate change impacts on gender roles along Agricultural Value Chain – processing, marketing, and consumption nodes. (Source: Deji 2019)

agroforestry. *The fallow system* encourages forest development; the forest is a carbon sink. *Agroforestry* is effective in carbon sequestration; it is a rational land use planning system that tries to establish a balance in food crop cultivation and forestry, leading to an increase in organic matter in the soil, which indirectly reduces the pressure exerted on forests. *Bush fallowing*: the use of natural fallows – leaving the land uncultivated for more than 2 years to regenerate or restore soil fertility to regenerate or restore soil fertility. *Organic manure application*: the application of compost, animal waste, and domestic wastes to the soil to maintain soil microbial activities and promote absorption of nutrients by plants. *Intercropping*: cultivation of more than one type of crop on a piece of land at the same time to reduce the risk of total crop loss/failure as well as providing good soil cover that minimizes soil erosion. *Conservation tillage*: minimal or no disturbance of soil; minimum or zero tillage; to respond to rapid soil deterioration and degradation caused by conventional tillage under harsh weather induced by climate change and variation.

5. **Water conservation/management practices:** *Rain harvesting* in pits and wells, barrels, to mention a few; *reuse of used water*; *rehabilitating degraded land*, planting of *drought-resistant crops* such as cassava, sweet potatoes, indigenous finger millet, to mention a few.
6. **Crop and farm management measures (risk-aversion practices):** Most farmers in developing countries like Nigeria do not enjoy formal insurance for risk aversion on their farms. Instead, they employ indigenous crop and farm management measures as climate change adaptation strategies, including *fragmented planting and harvesting*; *mixed cropping*; *multi-cropping*; *multiple investments*; *group farming*; *contract farming*; *decentralized or dispersed farming* – farming in one than one location at a time.
7. **Social capital/relation conservation measures:** Along the AVC, most male actors adapt to the unfavorable economic consequences of the climate change impacts through *role delegation*; *role commodification*; *role diversification*; *child commodification/child labor*; *rural-urban migration*: total or partial, economic or spatial, dual residency; and *livelihood diversification* to nonagricultural-related activities (vertical). *Role delegation* is a practice whereby most men delegate (substitution) their farming and family roles to the females, leading to extra burdens (addition) on the females' time, energy, and resources (Gender Response Theory). *Role commodification* means the strategy whereby most male AVC that have partially migrated or diversified to other jobs pays someone else to carry out their agricultural roles on their farms. *Child commodification* refers to the practice of exchanging children for money or material resources.

*Horizontal role dynamics* (by substitution) is popular among the males, while *vertical role dynamics* (by addition) is predominant among the female AVC actors. However, in livelihood diversification, male AVC actors diversify more into nonagricultural-related activities (*vertical livelihood diversification*). In contrast, the female AVC actors diversify mostly into agricultural-related activities (*horizontal livelihood diversification*) (Fig. 6).

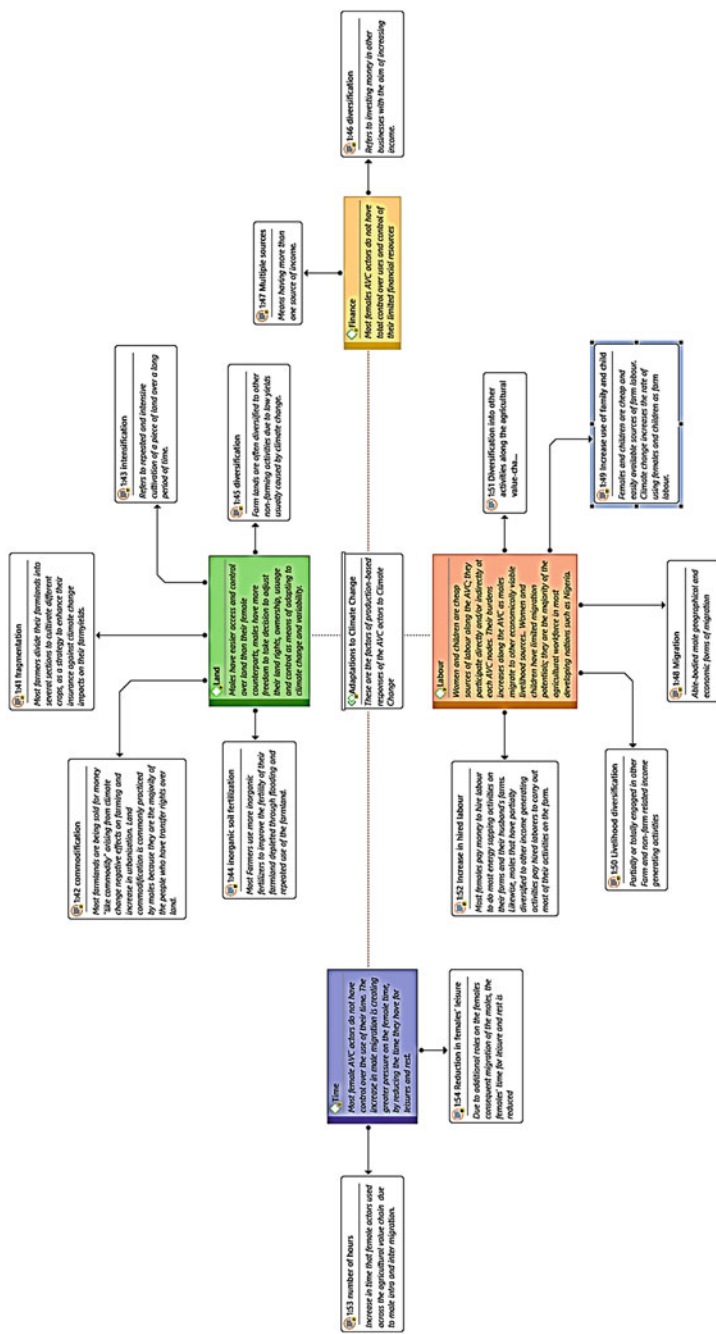


Fig. 6 Gendered resource-based adaptation strategies to climate change impacts. (Source: Deji 2019)

## Indigenous Early Warning Meteorological Adaptation Strategies

Most farmers in Nigeria do not have adequate access to scientific meteorological information; they often depend on their indigenous early warning strategies. In the face of growing climate change that makes accurate prediction of weather and weather forecasting very difficult, most farmers continue with their indigenous early warning knowledge as adaptation strategies to the climate change impacts.

The indigenous meteorology practices on early warning measures and knowledge are products of years of farming experience and acquired knowledge from parents and elders in the farming communities (Table 1). Most scientific meteorology knowledge is costly and requires technical skills to understand and adopt. On the contrary, indigenous meteorology practices are readily available and straightforward to understand and adopt by an average African farmer characterized by low literacy and socioeconomic power.

## Gender Implications of the Indigenous Climate Change Adaptation Strategies

Climate change is a significant threat to agricultural productivity and profitability, especially in a rain-fed agricultural nation like Nigeria. There is an increase in poor

**Table 1** Some common African indigenous early warnings and weather prediction. (Source: Deji 2019)

Indigenous early warning	Weather prediction
1. General yellowing and falling of tree leaves	Onset of Harmattan season (winter)
2. Flowering of the peach tree ( <i>Prunus persica</i> )	It is time to plant
3. Blooming of pear flower ( <i>Pryus communis</i> ) or roses ( <i>Rosa damascene</i> )	Time to plow
4. Regular chanting of red-chested birds ( <i>Cuculus solitaires</i> )	Time to plant regardless of the season
5. Half-moon facing east/full moon/rainbow on the sky	No rain to come
6. Increase in pests	More rain to fall
7. Increase in worms in the subsoil/surface of the soil	Season of summer and excessive rain/high water table/flooding possibility
8. Increase in frogs	Onset of thunder storms
9. Fruiting of brandy bush tree ( <i>Grewia flava</i> ):	
(a) Fruiting between November and December before the first rain in the year	Scanty or low rainfall
(b) Fruiting between February and March	Abundant rainfall
(c) No fruiting throughout the year	Drought
10. Flowering and fruiting of shepherd tree ( <i>Boscia albitrunca</i> ):	
Flowering and fruiting before the first rain	Year of abundant rainfall

agricultural yield leading to social and financial insecurity, reduction in farm-based income, and economic instability of the farm households. Indigenous adaptation strategies are commonly used among the AVC actors to reduce the negative impacts of climate change on their livelihoods. However, most of the indigenous adaptation strategies have implications on the social and gender relations, especially at the household levels, including:

1. **Role:** There is an increase in adult males' migration and diversification to nonagricultural income activities; female actors are more prominent at all the nodes along the AVC. Along the AVC, there is the high mobility of males from the production phase to the marketing phase, which promised better economic gains.
2. **Reordering of social and gender relations:** The male actors' spatial (rural-urban) and livelihood (from agriculture to nonagriculture) migration trend initiated by climate change is creating reordering of social and gender relationships within the farming households. Female AVC actors are increasingly occupying the spaces left along the AVC by most migrated males. Hence, there is an increase in females' involvement in decision-making, especially at the household level. Likewise, there is an improvement in females' access and control of resources at the household level.
3. **Responsibility:** There is an increase in responsibilities of and burdens on the female AVC actors. There is an increase in child labor and commodification (both males and females). Women and girls wake up early to fetch water for food preparation and irrigation of crops before herds come around the water to satisfy their increasing thirst due to an increase in temperature caused by climate change (which often results in herdsmen/farmers' conflict). Consequently, there is a reduction in the resting period for the females, which, in the long run, has negative health implications.

---

## Conclusions

Climate change has the potentials to increase the vulnerability of the poor. The unfortunate situation and conditions of most agricultural value actors, especially the females, exposes them to negative phenomena and make them hard-bitten. Climate change impacts are felt more on the poor living in the rain-fed regions such as Nigeria. The chapter confirms that:

1. Agriculture in Nigeria is rain-fed in nature; hence it is significantly impacted negatively by climate change and variability.
2. Climate change is threatening the livelihoods of Nigeria Agriculture Value Chain (AVC) actors, the majority of whom are the female small-scale holders with limited access to scientific expert-based adaptation and mitigation practices, hence increased food insecurity and poverty.

3. The female AVC actors are mostly affected by the climate change impacts due to their domestic and cultural roles, limited migration potentials, and the discriminating gender norms that limited their easy access and control over production resources and decision-making.
4. More of the female than male AVC actors experience difficulty in accessing resources due to gender discrimination and gender irresponsive policies and criteria dictated by the traditional and legal norms in the society.
5. Climate change and variability are influencing the reordering of social and gender relations among the AVC actors, especially at the household levels, most of which have implications for women empowerment and gender equality.
6. The indigenous adaptation strategies are different from the expert-based human intelligence (provided through extension service) and the artificial intelligence (machine intelligence); the indigenous intelligence is not regulated, lack accuracy, and hence not efficient and effective.
7. The low awareness and adoption of artificial intelligence-based climate-smart agricultural/adaptation strategies among the AVC actors were due to their low cultural compatibility, high cost, inadequate availability, gender limitation, complexity that requires high technicality, and competence.
8. Both male and female AVC actors adopted indigenous adaptation strategies because they were culturally compatible, available, low cost, and simple to understand and apply, while expert-based artificial adaptation strategies were not common among the AVC actors.
9. Mobility, especially rural-urban, was a typical indigenous adaptation strategy among the male AVC actors. Females have limited mobility/migration potentials being the dominant workforce in the domestic and caregiving services, especially at the household level.
10. Role commodification, role diversification, role delegation, and land commodification were popular strategies among males.
11. Horizontal role dynamics (by substitution) were most common among the male AVC actors, while the vertical role dynamics (by addition) were most common among the female AVC actors as indigenous adaptation strategies to climate change. In response to climate change and variability impacts, there was significant role-based social mobility (vertical and horizontal) within each AVC node among the male and female value chain actors.
12. Most male AVC actors adapted to climate change and variability by substituting activities and roles along the AVC and diversifying, mostly, into nonagriculture livelihood sources. On the contrary, most female AVC actors adapted to climate change and variability by taking up additional activities and roles (role intensification), usually within the agricultural value chain, as confirmed by the "Gender Response Theory – GRT."
13. According to Gender Response Theory, indigenous knowledge/ strategies could provide an enabling environment for the sustainable adoption of modern artificial knowledge and strategies.
14. The theory further reveals that males are more likely to substitute new knowledge/strategies for their indigenous adaptation knowledge/strategy, and adapt

faster than the females due to their higher economic and decision-making potentials. However, a response by addition (females' response) is usually more sustainable than a response by substitution (males' response).

15. Climate change is challenging social relations, especially at the household and community level. Examples are an increase in conflict between herdsmen and farmers, land-based conflicts, and child commodification.
16. Climate change is challenging the gender relations; female AVC actors are increasingly prominent and active in most activities along the AVC and decision-making and agency at the household and community levels due to the prevailing migration and livelihood diversification among active-aged males.

---

## Recommendations

Intervention programs and expert-based/artificial intelligence technology for climate change adaptation that will effectively enhance food security must recognize the indigenous strategies, knowledge, experiences, and practices, of the male and female AVC actors. Such programs must have in-built potentials to improve the social and economic situation and conditions as well as reduce the stress and burdens of the female actors along the AVC.

Furthermore, the male or female gender group is not homogenous on the bases of social variables such as age, education, ethnicity, social and economic status, marital status, family size, to mention a few. By implication, there might be variations in climate change impacts within each gender category at the different nodes along the AVC. Hence, there is a need for further gender analysis in AVC research using the intersectionality concept and methodology to enhance the inclusive understanding of the impacts and adaptation strategies within each gender group.

Also, research on climate change/variability must adopt an interdisciplinary approach using gender analysis methodology and theories for an inclusive understanding of the experiences and adaptation strategies among the different categories of the male and female AVC actors.

**Acknowledgments** The financial supports of the **Alexander von Humboldt Foundation** and the material and moral supports from the **Friedensau Adventist University** and **Obafemi Awolowo University** are acknowledged.

---

## References

- Acosta M, Ampaire E, Okolo W, Twyman J (2015) Gender and climate change in Uganda: effects of policy and institutional frameworks. CCAFS Info Note. Copenhagen, Denmark. CGIAR Research Program on Climate Change, Agriculture, and Food Security (CCAFS). Available online at: <http://www.ccafs.cgiar.org>. Accessed 10 Dec 2019

- Aduwo OE, Aransiola JO, Ikuteyijo LO, Alao OT, Deji OF, Ayinde JO, Oyedele DJ (2019) Gender differences in agricultural technology adoption in developing countries: a systematic review. *Acta Hort* 1238. <https://doi.org/10.17660/ActaHortic.2019.1238.24>
- Alao OT, Adebooye OC, Deji OF, Idris-Adeniyi KM, Agbola O, Busari AO (2014) Analysis of the impact of production technology and gender on under-utilized indigenous vegetables production in south-western Nigeria. *Afr J Sci Technol Innov Dev* 6(1). <https://doi.org/10.1080/20421338.2014.931741>
- Anaglo JN, Boateng SD, Boateng CA (2013) Gender access to agricultural resources by small-holder farmers in the Upper West Region of Ghana. *J Educ Pract* 5(5):13–19
- Apata TG (2013) Analysis of cassava value chain in Nigeria: from a pro-poor and gender perspective of farming households in southwest Nigeria. *Merit Res J Agric Sci Soil Sci* 2(11):147–153
- Bayeh E (2016) The role of empowering women and achieving gender equality to the sustainable development of Ethiopia. *Pac Sci Rev B Humanit Soc Sci*. <https://doi.org/10.1016/j.psr.2016.09.013>
- Christopher C, Jonathan M (2011) Gender and agricultural value chains: a review of current knowledge and practice and their policy implications. ESA working paper no. 11–05
- Deji OF (2019) Gender Response Theory (GRT); in climate change impacts on gender roles dynamics along agriculture value chain and implications for women farmers' empowerment in Nigeria: Why is the Intersectionality? A paper presented at Autumn conference of the Developmental Sociology/Social Anthropology Section (ESSA), Friedensau Adventist University, Germany, November 7–8, 2019. 48pp. And in climate change Adaptation and Mitigation strategies among farmers in Africa: Indigenous Intelligence vs Artificial Intelligence. A public lecture presented at Aula Hall, Friedensau Adventist University, Germany, December 11, 2019. 28pp
- Downie R (2017) Growing the agricultural sector in Nigeria. A report of the Center for Strategic and International Studies (CSIS) global food security project
- Eger C, Miller G, Scarles C (2018) Gender and capacity building: a multi-layered study of empowerment. *World Dev*. <https://doi.org/10.1016/j.worlddev.2018.01.024>
- Faniyi EO, Deji OF, Alabi DL, Ijigbade JO (2018) Soil and water conservation capabilities of male and female vegetable farmers on micro-veg project sites in southwestern Nigeria. *J Agric Ext* 22(3). <https://doi.org/10.4314/jae.v22i3.12>
- Faniyi EO, Deji OF, Oyedele DJ, Adebooye OC (2019) Gender assessment of vegetable farmers' utilization of soil and water conservation technologies in MicroVeg project sites, Southwest Nigeria. *Acta Hort* 1238:239–248. <https://doi.org/10.17660/ActaHortic.2019.1238.25>
- Food and Agriculture Organization of the United Nations (2010) Gender dimensions of agricultural and rural employment: Differentiated pathways out of poverty Status, trends and gap. Available: <http://www.fao.org/docrep/013/i1638e/i1638e.pdf>
- FAO (2019) FAO and the 2030 agenda for sustainable development. <https://doi.org/10.18356/ea058ce2-en>
- FAO and ECOWAS Commission (2018) National gender profile of agriculture and rural livelihoods–Nigeria. Country Gender Assessment Series, Abuja, 92pp
- Food and Agriculture Organization of the United Nations -FAO, UN (2015) Review of climate change adaptation and mitigation in agriculture in the United Republic of Tanzania, mitigation of climate change in agriculture (MICCA) program. The impact of disasters on agriculture and food security. Food and Agriculture Organization of the United Nations, Rome
- Food and Agriculture Organization (FAO) (2013) A tool for gender sensitive agriculture and rural development policy and program formulation: guidelines for Ministries of Agriculture and FAO. Food and Agriculture Organization of the United Nations, Rome
- Food and Agriculture Organization of the United Nations (FAO) (2011) The state of food and agriculture: women in agriculture closing the gender gap for developing. Rome, 160p. <http://www.fao.org/docrep/013/i2050e/i2050e.pdf>
- Gutierrez-Montes I, Arguedas M, Ramirez-Aguero F, Mercado L, Sellare J (2018) Contributing to the construction of a framework for improved gender integration into climate-smart agriculture



- projects monitoring and evaluation: MAP-Norway experience. *Clim Chang*:1–14. <https://doi.org/10.1007/s10584-018-2231-1>
- Intergovernmental Panel on Climate Change –IPCC (2014) Intergovernmental Panel on Climate Change (IPCC), ‘Summary for Policymakers’. In: Field CB, Barros VR et al (eds) *Climate change 2014: impacts, adaptation, and vulnerability. Part A: global and sectoral aspects, Contribution of Working Group II to the fifth assessment report of the Intergovernmental Panel on Climate Change*. Cambridge University Press, Cambridge UK/New York, pp 1–32
- Kolawole OD, Wolski P, Ngwenya B, Mmopelwa G (2014) Ethno-meteorology and Scientific weather forecasting: small farmers’ and Scientists’ perspectives on Climate variability in the Okevango Delta, Bostwana. *Clim Risk Manag Elsevier* 4–5:43–58
- Louman B, Campos-Arce JJ, Mercado L, Imbach P, Bouroncle C, Finegan B, Martínez C, Mendonza C, Villalobos R, Medellín C, Villanueva C, Mendoza T, Aguilar A, Padilla D (2015) Climate-Smart Territories (CST): an integrated approach to food security, ecosystem services, and climate change in rural areas. In: Minang PA, van Noordwijk M, Freeman OE, Mbow C, de Leeuw J, Catacutan D (eds) *Climate-smart landscapes: multi-functionality in practice*. World Agroforestry Center (ICRAF), Nairobi
- Myuri B, Obert J, Mafongoya PL (2017) Integration of indigenous and scientific knowledge in climate adaptation in Kwazulu-Natal, South Africa. *Change Adaptation Socioecol Syst De Gruyter* 3:56–67
- National Bureau of Statistics-NBS (2016) Nigeria gross domestics product report. Federal Government of Nigeria
- Okali C (2012) Gender analysis: engaging with rural development and agricultural policy processes. Working paper. [https://assets.publishing.service.gov.uk/media/57a08a7fe5274a31e000062a/FAC\\_Working\\_Paper\\_026.pdf](https://assets.publishing.service.gov.uk/media/57a08a7fe5274a31e000062a/FAC_Working_Paper_026.pdf)
- PRESANCA (2011) Centroamérica en Cifras. Datos de seguridad alimentaria nutricional y agricultura. [http://www.fao.org/fileadmin/user\\_upload/AGRO\\_Noticias/docs/CentroAm%C3%A9ricaEnCifras.pdf](http://www.fao.org/fileadmin/user_upload/AGRO_Noticias/docs/CentroAm%C3%A9ricaEnCifras.pdf)
- Raymond MC, Fazey I, Reed MS, Stringer LC, Robinson GM, Evelyn AC (2010) Integrating local and scientific knowledge for environmental management. *J Environ* 91:1766–1777
- United Nations Development Program-UNDP (2014) Human development report 2014 Sustaining human progress: reducing vulnerabilities and building resilience. UNDP, New York
- United States National Aeronautics and Space Administration -NASA (2016) Climate trends continue to break records. July 19, 2016 – <http://www.nasa.gov/feature/goddard/2016/climate-trends-continue-to-break-records>. 1 Oct 2016
- Williams PA, Crespo O, Abu M (2019) Adapting to changing climate through improving adaptive capacity at the local level-the case of smallholder horticultural producers in Ghana. *Clim Risk Manag Elsevier* 23:124–135

**Open Access** This chapter is licensed under the terms of the Creative Commons Attribution 4.0 International License (<http://creativecommons.org/licenses/by/4.0/>), which permits use, sharing, adaptation, distribution and reproduction in any medium or format, as long as you give appropriate credit to the original author(s) and the source, provide a link to the Creative Commons license and indicate if changes were made.

The images or other third party material in this chapter are included in the chapter’s Creative Commons license, unless indicated otherwise in a credit line to the material. If material is not included in the chapter’s Creative Commons license and your intended use is not permitted by statutory regulation or exceeds the permitted use, you will need to obtain permission directly from the copyright holder.





# Impact of Climate Change on Animal Health, Emerging and Re-emerging Diseases in Africa

# 90

Royford Magiri, Kaampwe Muzandu, George Gitau, Kennedy Choongo, and Paul Iji

## Contents

Introduction .....	1836
Africa's Current Climatic Zones .....	1837
Expected Impacts of Climate Change on Livestock Production and Health .....	1838
Vulnerability of Livestock Production Systems to Climate Change .....	1839
Direct Effects of Climate Change on Animal Physiology: Metabolic Alterations, Suppressed Reproduction, Oxidative Stress, Immune Suppression, Morbidity, and Mortality .....	1839
Pathogen and Vector Ecology .....	1840
Pathogen Transmission Ecology and Climate Change .....	1840
Vector Ecology and Climate Change .....	1840
Vector-Borne Infections as Models of the Effect of Climate Change on Animal Health .....	1841
Insect-Borne Diseases .....	1841
Tick-Borne Diseases .....	1843
Non-Vector-Borne Diseases as Models of the Effect of Climate Change on Animal Health .....	1843
Terrestrial Non-Vector-Borne Diseases .....	1844
Aquatic Non-Vector-Borne Diseases .....	1844

This chapter was previously published non-open access with exclusive rights reserved by the Publisher. It has been changed retrospectively to open access under a CC BY 4.0 license and the copyright holder is "The Author(s)". For further details, please see the license information at the end of the chapter.

R. Magiri (✉) · P. Iji  
Fiji National University, College of Agriculture, Fisheries and Forestry, Suva, Fiji  
e-mail: [royford.magiri@fnu.ac.fj](mailto:royford.magiri@fnu.ac.fj)

K. Muzandu  
School of Veterinary Medicine, University of Zambia, Lusaka, Zambia

G. Gitau  
Faculty of Veterinary Medicine, University of Nairobi, Nairobi, Kenya

K. Choongo  
Fiji National University, College of Agriculture, Fisheries and Forestry, Suva, Fiji  
School of Veterinary Medicine, University of Zambia, Lusaka, Zambia

Determination and Use of Meteorological, Vector and Health Data for Assessing and Mitigating Impacts of Climate Change on Animal Health .....	1845
Animal and Farmer Resilience and Adaptation to Effects of Climate Change on Animal Health .....	1846
Community Resilience and Adaptation .....	1846
Animal Management Adaptations .....	1847
Adaptation by Strengthening Disease Prevention Practices .....	1848
Conclusion .....	1848
References .....	1849

## Abstract

The threat of climate change and global warming is gaining worldwide recognition. The African continent, because of its size, diversity, and its new status as a “hub” of livestock production, need to gear up to mitigate the possible impacts of climate change on animal health. The aim of this review article is to summarize the current state of knowledge regarding the influence of climate and climate change on the health of food-producing animals. Depending on its intensity and duration, heat stress may directly affect livestock health by causing metabolic disruptions, oxidative stress, and immune suppression, causing increased disease susceptibility, and death. Animal health could also be affected by emergence and re-emergence of vector- and non-vector-borne pathogens that are highly dependent on climatic conditions. The response to these challenges requires community participation in the adaptation of animal production systems to new environments and strengthening the efficiency of veterinary services delivery combined with well-coordinated public health services, since many emerging human diseases are zoonotic.

## Keywords

Global warming · Extreme weather · Livestock vulnerability · Adaptation strategies

## Introduction

Agriculture serves as the backbone of the economy of most African countries and is the largest domestic income producer. Moreover, it employs about 70–90% of the total working population (Chauvin et al. 2012). Interestingly, this sector supplies up to 50% of household food demand in addition to their income. The livestock subsector provides over half of the value of global agricultural output and one-third in developing countries in Africa. The demand for livestock products in the developing countries is increasing with increasing human population (Steinfeld et al. 2006). However, the livestock subsector is highly susceptible to extreme climate variability. The effect of climate change is anticipated to heighten the susceptibility of livestock production systems to emerging and re-emerging diseases. Climate change is arguably the most important environmental issue currently

affecting the livestock sector, but also ecological systems, peoples' livelihoods, and species survival (Zougmore et al. 2016). Documented effects of climate change are: increasing number of warmer days and nights in a year; changes in rainfall pattern and volume; longer summer seasons; rising sea-levels; and increasing frequency and intensity of floods, droughts, and heat waves (Field et al. 2012; Hughes 2003). Several African governments and regional organizations are aware that increasing demand for livestock products in Africa is not matched by similar growth in local livestock production and are working towards addressing this mismatch in order to reduce dependence on imports.

Unfortunately, there is a lot of emphasis on the impact of climate change on crops in global discussions on climate with little attention paid to livestock production. There is urgent need for a paradigm shift, since it is a fact that even when there is severe crop failure, indigenous livestock have helped vulnerable communities to survive. However, the resilience of indigenous livestock is also threatened by various factors, including extreme climate variability coupled with indiscriminate cross-breeding. With climate change taking the center stage, there is merit in developing indigenous livestock due to their ability to adapt to stressful environments.

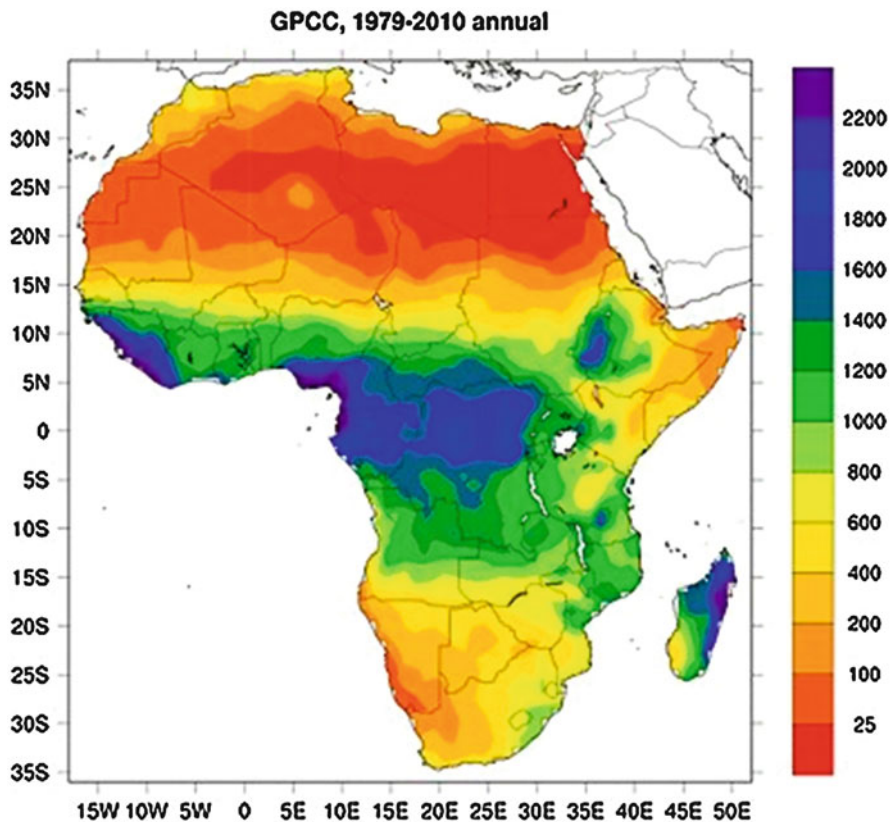
The risks associated with unmanaged livestock production in the face of climate change are causing decision-makers in Africa to raise a number of questions such as: What kind of policies would expand livestock production and give societies equal benefits? What is the best way to ensure good health for the people? What choices can ensure that livestock production is socially, biologically, economically, and climatically sustainable? Therefore, the objective of this chapter is to provide some answers to these questions by reviewing the impact of climate change on livestock production, emerging and re-emerging diseases, and adaptation strategies.

---

## Africa's Current Climatic Zones

Climate is a long-term pattern of weather, which is the sum of sunshine, temperature, rainfall, and wind. The amount of heat from the sun plays a significant role in determining climate. The equator cuts across the center of Africa, making it the most tropical continent in the world with different regional climatic conditions (Cooper et al. 2008). The northern to north-eastern parts of the continent and the south-western part of southern Africa have hot and dry climate with unreliable summer rainfall and arid to desert landscape (Gasse 2000). Countries along the equator experience warm and humid climate with heavy summer rainfall for most part of the year and characterized by tropical rain forests. The tropical but not equatorial regions have warm and moist climate with summer rainfall and savanna vegetation. Small areas at the northern and southern tips of Africa have Mediterranean climate, characterized by hot, dry summers and cool, wet winters.

Most of the rain in Africa occurs in the middle of the continent in the north-west to south-east direction (Fig. 1). The influence of cool-drier south-westerly prevailing



**Fig. 1** Map of Africa showing annual average rainfall (mm) averaged between 1979 and 2010. (Siebert 2014)

winds reduces rainfall in the south-western part of Africa while the hot-drier north-easterly trade winds reduce rainfall in the north to north-east Africa.

## **Expected Impacts of Climate Change on Livestock Production and Health**

Africa's contribution to global warming is low while the people living in Africa may be hit hardest by its impact. The overall impact of climate change on animal production and health is far greater than, a mere increase in average annual temperature. The effects of climate change on animal health may be direct or indirect. The direct effects are mainly due to changes in environmental conditions such as air temperature, relative humidity, precipitation, drought, and floods (Lacetera 2019). These environmental conditions are responsible for temperature-related animal morbidity and mortality. Indirect effects of climate change on animal health and

production are due to microbial density and distribution of vector-borne diseases, food and water shortages, or foodborne diseases (Lacetera 2019). The impact is characterized by: reduced feed quantity and quality; reduced feed intake; water scarcity; increased frequency and severity of diseases and deaths; poor growth rate; decreased quantity and quality of meat and milk; poor reproductive performance; increased costs for disease control and animal production (Thornton et al. 2009). All these culminate into decreased animal health and productivity, decreased animal welfare, and reduced income for affected communities and countries at large.

---

## **Vulnerability of Livestock Production Systems to Climate Change**

Resilience to the impact of climate change depends on the vulnerability of affected animals and communities. Such vulnerability is the degree to which African livestock production systems are susceptible or incapable of coping with the adverse effects of climate change. In general, developing countries are more vulnerable to the impacts of climate change because they are exposed to many challenges at any time and have limited capacity to adapt. The African livestock sector is particularly vulnerable because of variability of climate, existing disease burdens, culture and economic circumstances, strong dependence on natural resources, weak infrastructure, institutional weaknesses, political and social instability (Thornton et al. 2007).

---

## **Direct Effects of Climate Change on Animal Physiology: Metabolic Alterations, Suppressed Reproduction, Oxidative Stress, Immune Suppression, Morbidity, and Mortality**

New et al. (2006) analyzed the daily maximum and minimum temperatures and precipitation data from Southern and West African countries for the period 1961–2000. They found a consistent trend of increasing number of hot days and nights and decreasing extremely cold days and nights. Heat stress can occur in animals when a combination of animal and environmental factors increase body heat beyond the normal range (Young 1993). Cattle respond to acute periods of excessive heat in many ways, including decreased feed and increased water intake and increased respiratory rate (Gaughan et al. 1999). On the other hand, Beatty et al. (2006) showed that *Bos taurus* cattle experienced significant physiological changes while similar but less pronounced changes were experienced by *Bos indicus* but without a decrease in feed intake, when exposed to prolonged heat and humidity.

Heat stress due to fluctuating environmental temperatures that exceeds the thermoneutral zone for an animal is the most common stressor that can cause physiological, endocrine and immune responses that may lead to morbidity and reduced animal production (Carroll et al. 2012). Similarly, there was an increase in oxidative stress in dairy cows during the hot season (Tanaka et al. 2007). An increase in oxidative stress has been shown to increase the pathogenesis and severity of many diseases (Halliwell and Gutteridge 1990).

Thus, direct effects of climate change on livestock physiology are observed through the increase in heat stress and have been shown to reduce resistance to diseases and reduce reproductive efficiency and productivity in general. However, heat-tolerant local animals easily adapt compared to heat-susceptible ones.

---

## **Pathogen and Vector Ecology**

The life cycle of most pathogens involves a free-living stage in the environment while most vectors spend most of their time off the host and only come in contact with animals at the time of feeding.

## **Pathogen Transmission Ecology and Climate Change**

Animal pathogens can live in the body of a host/vector or be free-living in the environment. These pathogens are more susceptible to direct effects of weather change when they are free-living in the environment. The major climate-related factors limiting pathogen survival in the environment are temperature and humidity. Climate change in Africa is causing an increase in the number of days that are hot compared to those that are cold in a year (New et al. 2006). The increasing numbers of hotter days in turn reduce humidity thereby reducing the survival of free-living pathogens in the environment. For instance, the survival of viruses during aerosol transmission or by surface contact is influenced by humidity and ambient temperature (Lowen et al. 2007). Since drought is associated with higher temperatures and low humidity and reduced availability of water, it tends to reduce the survivor and transmission of free-living pathogens into host animals.

Floods increase air humidity and create conditions favorable for survival and transmission of free-living pathogens. For example, the transmission of avian influenza viruses involves the ingestion of water containing the virus (Domanska-Blicharz et al. 2010). Similarly, helminthes and other larger parasites that have a long free-living stage thrive better during weather conditions that increase water availability (van Dijk et al. 2010). Therefore, the effects of climate change on free-living pathogens may take different forms due to fluctuations between drought and flood years. Each pathogen in an area must be assessed on its own merit in order to have a practical adaptation strategy. Furthermore, many pathogens have short generation intervals and high rates of mutation, increasing their ability to evolve over decades and cause emerging diseases (Koelle et al. 2005).

## **Vector Ecology and Climate Change**

In Africa, disease-transmitting vectors are equally affected by increasing number of days with hot weather and low humidity. For vectors whose life cycle involves egg, larval, nymph, and adult stages, the egg and larval stages are the most susceptible to

changing weather patterns. It has been shown that the hatchability of *Rhipicephalus decoloratus* eggs reduces when temperatures are low during cold season or flood periods, while larval survival decreases when humidity is low during hot months (Leal et al. 2018). This means that warmer cold seasons and drought increase the population of these ticks and increases the risk of anaplasmosis and babesiosis, while hot seasons with low humidity decrease the population and the risk of these diseases. Similarly, higher temperatures observed during cold seasons (Elbers et al. 2015) and flooding (Ivers and Ryan 2006) may be linked to increased mosquito and *Culicoides* midge populations, thereby increasing the risk of diseases that they transmit such as lumpy skin Disease, Rift Valley Fever among others.

---

## **Vector-Borne Infections as Models of the Effect of Climate Change on Animal Health**

There is ample literature on the effects of climate change and the epidemiology of several vector-borne species on animal and human diseases. Vector-borne animal diseases in Africa fall into two main categories: (1) Insect-borne diseases spread by mosquitoes, midges, biting flies, and Tsetse fly which transmit diseases such as Trypanosomiasis and Rift Valley Fever; (2) tick-borne diseases such as East Coast Fever (Bengis et al. 2002).

The mechanisms involved in the emergence of such diseases relating to climate are complex. Vector-borne diseases are usually transmitted by interaction between the hosts and the infected vectors. Infection prevalence is dependent on the interrelationship between hosts, pathogens, and vectors. Any climate-related factor affecting this triangular relationship will affect the vector-transmitted disease epidemiology. In this respect, the survival of the vector, its replication, distribution, density, the vector biting rate, and the pathogen's incubation rate within the vector are of particular importance.

A rise in temperature can allow some vector-borne illnesses to spread in areas with adequate rainfall. Indeed, in the absence of effective veterinary services, the spread of vector-borne diseases is largely determined by a natural boundary where environmental or climatic conditions limit the distribution of the vector and, therefore, the pathogen. Small changes in climatic conditions can have significant repercussions for disease transmission at the fringes of this natural distribution and interfere with endemic stability.

### **Insect-Borne Diseases**

These include (a) arboviral diseases, for example, Rift Valley Fever, Lumpy Skin Disease and African Horse Sickness (b) protozoa diseases, for example, Trypanosomiasis. In the following sections, we will provide evidence, linking climate change to the spread of these diseases.



### **Mosquito-Borne Diseases**

Rift Valley Fever (RVF) is a significant arboviral disease already linked to climate change. It is a peracute or acute zoonotic disease, but affecting mainly domestic ruminants in Africa and transmitted by the mosquito (Mellor and Leake 2000). It is most serious in sheep and goats, resulting in death in newborn animals and abortion in pregnant animals. Epidemics associated with heavy rainfall at irregular intervals of 5–15 years tend to occur in eastern and southern Africa but some outbreaks in Sudan, Egypt, Senegal, and Mauritania are not related to any change in rainfall pattern. Heavy rainfall causes flooding of often dry areas and contributes to the hatching of dormant, drought-resistant, infected *Aedes* mosquito eggs responsible for the maintenance of the infection in dambos. Emerging mosquitoes infect an amplifying host that becomes a source of infection for many other mosquitoes that spread the disease rapidly.

Rift Valley fever outbursts are accompanied by unexpected heavy rains and flooding, mostly caused by El Niño. For example, the 1997–1998 and 2007 El Niño events were associated with very heavy rainfall in north-eastern Kenya and southern Somalia, resulting in a significant outbreak of RVF (Sang et al. 2010). Rift Valley Fever outbreaks in North and West Africa are not associated with heavy rainfall but with large rivers and dams providing ideal breeding grounds for mosquito vectors. In these areas, increasing the water storage ability for agricultural development and irrigation, in response to the drying climate, is likely to provide new suitable breeding sites for mosquitoes and may make these areas more vulnerable to RVF epidemics. In addition, RVF may become prevalent in areas where the disease has not been previously reported. Wessel born disease (WSL) is another mosquito-borne viral disease of cows, sheep, and goats that largely depends on floodwater breeding *Aedes* mosquitoes, and has very close epidemiological characteristics to RVF. Lumpy skin disease is a cattle disease of economic importance in Africa, causing severe losses such as damage to hides, mortality, and losses in productivity and reproduction (Krauer et al. 2016).

### **Midge-Borne Diseases**

Wet conditions also promote the breeding of biting flies (e.g., *Culicoides* (Midges), *Stomoxys* and *Tabanus* spp.). African horse sickness (AHS) and bluetongue (BT) viruses are triggered by *Culicoides* biting midges. Therefore, the dissemination of both diseases is greatly affected by the availability of favorable conditions for breeding of midges. Blue Tongue disease was originally restricted to a belt between 40°N and 35°S worldwide. Its spread to other parts of the world has been attributed to climate change. Some major AHS outbreaks in South Africa have been linked to the combination of drought and heavy rainfall caused by El Niño-Southern Oscillation's (ENSO) warm phase. Many global climate models predict that, in the future, ENSO will occur more often.

### **Tsetse Fly-Transmitted Diseases**

The direct and indirect effects of climate change on tsetse fly distribution and abundance would help to determine the possible spread and prevalence of trypanosomiasis in livestock (Bett et al. 2017). However, a recent study forecasting the

expected impact of climate change on the distribution of tsetse flies suggests that the impact of climate change on population results is minimal in comparison with the consequences of population growth and the concomitant shifts in land use and tsetse natural habitat. The biggest shifts in tsetse fly distribution are predicted in the drier areas of western, eastern, and southern Africa (McDermott et al. 2002). Climate change will have less impact on tsetse fly distribution in the tropical regions of Africa. Nevertheless, the potential consequences of increased temperatures and habitat suitability changes on the vector capability of tsetse flies are not clear, and further research is needed.

## Tick-Borne Diseases

Diseases which are caused by tick-transmitted pathogens in Africa include: (a) protozoal diseases (Theileriosis and Babesiosis), (b) rickettsial diseases (Anaplasmosis and Heartwater disease), and (c) viral diseases (African Swine fever).

Ticks spend a significant portion of their lives feeding off their host(s) and are therefore prone to atmospheric temperature and humidity. The climate and vegetation influence the environment and determine the distribution and abundance of ticks. Rising temperature, as a result of climate change can shorten their life cycle yet increase their reproductive rate (Estrada-Peña et al. 2012). Rather high temperatures are likely to reduce their longevity, and under drier conditions, mortality may increase. A model developed for the brown-ear tick *Rhipicephalus appendiculatus*, the main vector of East Coast fever (ECF), forecasts that ideal environments for the tick will have vanished in most of the southeastern portion of its distribution by the 2050s. Conversely, in western and central parts of southern Africa, more ideal places for tick survival could appear. A strong correlation between El Niño occurrences and an enhanced ECF seroprevalence has been identified in southern Zambia as a result of the increased tick vector survival (Fandamu et al. 2005). Consequently, temperature strongly affects the nature of the tick population and the diseases they spread by influencing tick distribution and seasonal incidence. Regulation of the big tick-borne diseases in large areas of Africa should focus on preserving an endogenous stable situation.

Therefore, the growth and survival of infectious immunity in bovine with tick-borne diseases is dependent on an optimum interaction between cattle, disease agents, and ticks. Disruption of this optimum relationship due to climate change and subsequent changes in the distribution and availability of certain types of ticks is likely to affect endemic stability and could trigger disease outbreaks.

---

## Non-Vector-Borne Diseases as Models of the Effect of Climate Change on Animal Health

Non-vector-borne diseases are transmitted directly after infectious organisms from the environment enter the animal, usually through inhalation (aerosol) and/or ingestion (water or feed) or through open wounds.

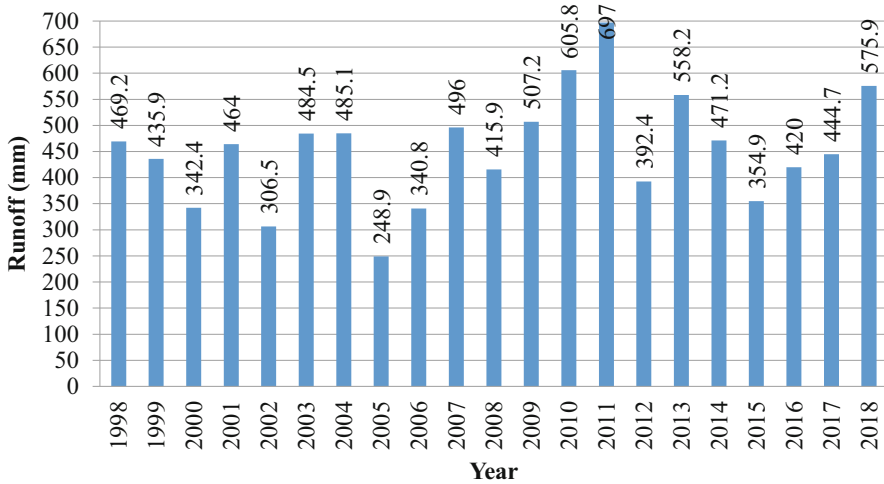
## Terrestrial Non-Vector-Borne Diseases

The effect of climate change on the spread of non-vector-borne diseases and their occurrence varies greatly. Changes in environmental conditions may increase or decrease the survival of the infectious agent in the ecosystem or predispose the susceptible animals to infection, as a direct or indirect result of climate change. A changing environment can also lead to increased or decreased interaction between contaminated and vulnerable species, and therefore influence transmission. Changes in temperature and humidity may influence the spatial and temporal distribution of non-vector-borne disease pathogens that spend time outside the host (Van den Bossche and Coetzer 2008). Such infections include: anthrax and blackleg, peste des petits ruminants (PPR), and foot and mouth disease (FMD) found in wind-borne aerosols, dermatophilosis, haemorrhagic septicaemia, coccidiosis, and helminthiasis (Van den Bossche and Coetzer 2008). The increase in rainfall in some areas of Africa creates temporary water bodies or permanent water bodies for irrigation in drier areas in which the intermediate snail host of *F. hepatica* survives (Van den Bossche and Coetzer 2008). While disease spread directly between animals in close contact is less climate-related, changes in the environment resulting in the loss or sporadic availability of water resources or grazing land lead to mass migration of livestock and wildlife in pursuit of water or pasture. Such movement enhances the interaction between livestock from different areas, and between wildlife and livestock, and can contribute to pathogens being transferred. Such population gatherings, animal congregations, and exchange of water and food supplies are considered to significantly contribute to the dissemination of major transboundary African diseases such as FMD, PPR, and contagious bovine pleuropneumonia. Drought, overgrazing, and extreme environmental stress arising from climate change and/or mass migration can become significant trigger factors for soil-borne disease epidemics, such as anthrax which remains dormant and viable in the soil for several decades.

Foot rot is a flood-related bacterial condition that affects ruminant interdigital tissue. Changes in the quality of the interdigital surface, due to exposure to wet conditions during floods, provide a favorable environment for bacterial growth and foot rot (Hiko and Malicha 2016). Changes in the environment as a result of climate change will also affect the migratory paths of a large range of bird species, both within and across continents. These movement path modifications can play a role in the spread and distribution of avian influenza and West Nile virus (Altizer et al. 2011).

## Aquatic Non-Vector-Borne Diseases

Epizootic Ulcerative Syndrome (EUS) is a disease characterized by red spots and ulcers on the skin and often high mortality of various fish species (Songe et al. 2011). The lesions of EUS are caused by *Aphanomyces invadans*, and poor water quality parameters predispose fish to EUS (Pathiratne and Jayasinghe 2001). The first outbreak of EUS in Africa was recorded in 2006 in Botswana, Namibia, and Zambia in the Chobe-Zambezi river basin (Andrew et al. 2008). This was associated with



**Fig. 2** Total annual water runoff on Zambezi River in Mongu, Zambia from 1998 to 2018 showing the lowest ever water runoff below 250 mm in 2005 due to severe drought. (Source of data, Brakenridge 2020)

river basins having thionic gleysols, soils with enough sulfur content to cause acidification of the soil upon oxidation (FAO/UNESCO 1970), and the severe drought of 2005 (Fig. 1; Brakenridge 2020) that drastically reduced the water table to expose the sulfide/sulfur horizon to air oxidation, resulting in acidic pH and poor water quality (Choongo et al. 2009). The high rainfall of 2006/2007 season flushed the acidic underground water to the surface, creating favorable conditions for the disease. It was observed that the disease was spreading upstream towards the underground source of the water, rather than downstream where all the dead and infected material were being washed to by the water. It is interesting to note that the water runoff on the Zambezi River has up until 2018, never reduced to the 2005 level of less than 250 mm and the EUS disease is so far naturally under control.

Thus, it would be important to use river water runoff data and any other meteorological data that can be used to predict future outbreaks of EUS in areas with underwater sulfur content that can be acidified when exposed to air due to lowering water table during severe drought. This would enable aquaculture farmers in such areas as the Chobe-Zambezi river basin prepare their fish ponds for sufficient alkalization with lime in order to mitigate the possible outbreak of EUS (Fig. 2).

## Determination and Use of Meteorological, Vector and Health Data for Assessing and Mitigating Impacts of Climate Change on Animal Health

The availability of reliable meteorological and disease data is necessary to design effective disease monitoring, surveillance, and early warning and response systems. The major sources of meteorological data, including temperature and precipitation,

are obtained from ground-based and satellite measurements or interpolated gridded datasets (Heaney et al. 2016).

A web search for articles published between 1970 and 2015 on meteorology and infectious diseases in Central Africa by Heaney et al. (2016) concluded that in Central Africa, meteorological data is limited because of sparse ground-based recording stations and the lack of proper validation of available satellite data. Therefore, most studies done on the link between infectious diseases and meteorological variability may not be reliable unless infectious disease data are linked to high-quality spatially matched weather data. Spatial mismatch happens when humidity, temperature, and rainfall estimates are obtained from a place that was far from the area where disease data was collected. They advised the scientific community to be aware of the limitations of meteorological data available in Africa and ensure that there is an improvement in the quality and quantity of both meteorological and infectious disease data collected.

“Environmental change vulnerability,” which includes community exposure to climatic change, its sensitivity and ability to adapt (McLeman and Hunter 2010), is considered to be very high in African countries. Thus, the need to have quality meteorological and disease data cannot be overemphasized.

---

## **Animal and Farmer Resilience and Adaptation to Effects of Climate Change on Animal Health**

Coping and adapting to negative effects of climate change on animal health requires that the farming community adapts to changing circumstances, animal management systems are adapted and animal disease preventive measures are strengthened. It should no longer be business as usual.

### **Community Resilience and Adaptation**

Most of the climate-associated emerging and re-emerging animal diseases are transmitted by agents that do not respect any boundaries and therefore, require collective stakeholder participation if effective control for improved productivity is to be achieved. In most African countries, government infrastructure meant to support farmers in livestock production and health is either very poor and unreliable or nonexistent at all. However, when assistance from government or NGOs exist, most of it focuses on the usual aspects of disease control and animal production and not really mitigating effects of climate or weather changes that increase effects of diseases on their animals. Therefore, empowering communities with knowledge and skills to adapt to climatic and weather patterns should now be a priority. Community participatory disease control and surveillance have been practiced in some areas and when supported by government projects or NGOs may yield variable results, which usually disappear when the project or support ends. This is normally the case when project activities are compromised by poor objectives and subjective practicality

(Ayal and Muluneh 2014). In order to have really lasting benefits, there is a need to implement sustainable community based herd health programs that integrate all activities such as vaccinations, deworming, etc., into the day-to-day husbandry, with increased livestock off-take where, there is government marketing support. It has been shown that when farmer livelihood sustainability through improved income becomes the goal of their community participation, tangible results are usually obtained. The rinderpest eradication program was one such success story because livelihood sustenance was the ultimate rationale for collective community efforts (Rich et al. 2014). Therefore, resilience and adaptation to effects of climate change in Africa require that the affected communities are directly involved in adaptation strategies that are practical and centered on livelihood sustenance.

## **Animal Management Adaptations**

Although severe droughts and floods are all considered to be a result of climate change, drought by far has the greatest impact on animal production because it drastically limits both feed and water availability. Limited feed, both in terms of quality and quantity, reduces the competence of the immune system thereby making the animals more susceptible to diseases. In most parts of Africa both feed and water are abundant during flood years. Therefore, in most cases, climate change livestock production adaptation strategies that are usually considered are those responding to the impact of drought. Floods may affect animal production more through diseases than through nutrition. Adaptation strategies can be short-term or long-term.

Unfortunately, most farmers tend to implement short-term adaptation strategies because they have immediate visible impact although they are not usually sustainable in many cases especially for large flocks or herds. Short-term strategies include increasing spending on veterinary services, destocking, trekking animal's long distances in search of water and pasture, constructing fences to protected farmland, as well as feeding through cut-and-carry and other zero-grazing practices.

Long-term resilience to effects of climate change should make management of animals according to local conditions priority number one (Nyamushamba et al. 2017). This should start by ensuring that there are a large percentage of genes from local animals in the breeding stock. Indiscriminate cross-breeding should be discouraged as it produces offspring that are not well adapted and succumb easily to any emerging diseases. Even in the midst of climate change, local breeds have traits for genetic resistance to disease and other traits for quickly adjusting to local conditions. Other management practices like feeding and housing play an important role in the maintenance of resilient, healthy, and productive animals. In fact, continuous breeding of the best performing animals under the harsh local environmental conditions is the more sustainable long-term adaptation strategy. There are many examples of resilient animal breeds that have been developed with mainly local genetics that are performing very well even in the midst of climate change. These include the Tuli and Boran cattle breeds. However, livestock farmers that have maintained their indigenous cattle breeds such as Sanga in Southern Africa (Norval et al. 1988), East

African zebu (Scarpa et al. 2003), and the N'dama in West Africa (Mattioli et al. 2000) suffer less from the impact of environmental changes compared to those that keep breeds with a large percentage of exotic genetics.

Thus management adaptation to changing climate requires committed allocation of resources and improvements in the way land is used for livestock production, coupled with the promotion of local genetics.

## **Adaptation by Strengthening Disease Prevention Practices**

The impact and prevalence of many diseases such as FMD, theileriosis, anaplasmosis, etc., have been increasing while the budget for controlling the diseases has been reducing in most African countries. Sufficient resources must be allocated while ensuring that the whole community is involved in improving sanitation and biosecurity. Usually disease risk factors vary with animal management systems. However, irrespective of the management system, early warning, detection, and quick response are key to preventing and controlling both emerging and re-emerging animal diseases (Black et al. 2008). Prevention and stopping the spread of diseases across an area and country should be the cornerstone of all preventive mechanisms. In addition, in order to stop the spread of high impact infectious diseases such as FMD and ASF, transboundary control measures by African countries are required. The success of the rinderpest eradication program was a result of early detection and early response globally. The world was declared to be free of rinderpest by both FAO and OIE in 2011 because of commitment to early detection and early response (Mariner et al. 2012). Unfortunately, in Africa, new diseases continue to emerge and the impact and persistence of endemic diseases is still a major challenge. In order to achieve early detection and early response, African countries must have functioning laboratories that give real time results of disease confirmation which are well coordinated with field veterinarians.

---

## **Conclusion**

Climate change has certainly increased land and sea surface temperatures, leading to an increase in the number of warmer days and nights in a year. These changes have been shown to increase the severity of droughts and floods. The manner in which these climatic changes affect animal health and production has been highlighted in this review. The impact can be directly, by affecting the animal's thermoneutral zone thereby inducing stress and its subsequent effects. The effect can also be indirectly by increasing the survival of pathogens and vectors in the environment resulting in increased severity and frequency of diseases. The use of meteorological data that are spatially matched to disease data can help in achieving early warning, detection, and response to eminent diseases. In Africa, adaptation measures should include livelihood-sustenance based community participation in managing animal production according to local conditions and strengthening disease preventive practices.

## References

- Altizer S, Bartel R, Han BA (2011) Animal migration and infectious disease risk. *Science* 331(6015):296–302
- Andrew T, Huchxermeyer K, Mbeha B, Nengu S (2008) Epizootic ulcerative syndrome affecting fish in the Zambezi river system in Southern Africa. *Vet Rec* 163:629–632
- Ayal D, Muluneh A (2014) Smallholder farmers' vulnerability to climate variability in the highland and lowland of Ethiopia: implications to adaptation strategies. Doctoral thesis, University of South Africa, Geography Department
- Beatty DT, Barnes A, Taylor E, Pethick D, McCarthy M, Maloney SK (2006) Physiological responses of *Bos taurus* and *Bos indicus* cattle to prolonged, continuous heat and humidity. *J Anim Sci* 84(4):972–985. <https://doi.org/10.2527/2006.844972x>
- Bengis R, Kock R, Fischer J (2002) Infectious animal diseases: the wildlife/livestock interface. *Rev Sci Tech-Off Int Épizooties* 21(1):53–66
- Bett B, Kiunga P, Gachohi J, Sindato C, Mbotha D, Robinson T, ... Grace D (2017) Effects of climate change on the occurrence and distribution of livestock diseases. *Prev Vet Med* 137:119–129
- Black PF, Murray JG, Nunn MJ (2008) Managing animal disease risk in Australia: the impact of climate change. *Rev Sci Tech-Off Int Epizooties* 27(2):563–580
- Brakenridge GR (2020) Global active archive of large flood events. Dartmouth Flood Observatory, University of Colorado. <https://floodobservatory.colorado.edu/SiteDisplays/278.htm>. Accessed 8 Feb 2020
- Carroll JA, Burdick NC, Chase CC Jr, Coleman SW, Spiers DE (2012) Influence of environmental temperature on the physiological, endocrine, and immune responses in livestock exposed to a provocative immune challenge. *Domest Anim Endocrinol* 43(2):146–153
- Chauvin ND, Mulangu F, Porto G (2012) Food production and consumption trends in sub-Saharan Africa: prospects for the transformation of the agricultural sector. UNDP Regional Bureau for Africa, New York
- Choongo K, Hang'ombe B, Samui KL, Syachaba MZ, Phiri H, Maguswi C, Muyangaali K, Bwalya G, Mataa L (2009) Environmental and climatic factors associated with epizootic ulcerative syndrome (EUS) in fish from the Zambezi Floodplains, Zambia. *Bull Environ Contam Toxicol* 83(4):474–478
- Cooper P, Dimes J, Rao K, Shapiro B, Shiferaw B, Twomlow S (2008) Coping better with current climatic variability in the rain-fed farming systems of sub-Saharan Africa: an essential first step in adapting to future climate change? *Agric Ecosyst Environ* 126(1–2):24–35
- Domanska-Blicharz K, Manta Z, Smietanka K, Marche S, van den Berg T (2010) H5N1 high pathogenic avian influenza virus survival in different types of water. *Avian Dis* 54(1 suppl): 734–737
- Elbers AR, Koenraadt CJ, Meiswinkel R (2015) Mosquitoes and Culicoides biting midges: vector range and the influence of climate change. *Rev Sci Tech* 34(1):123–137
- Estrada-Peña A, Ayllón N, De La Fuente J (2012) Impact of climate trends on tick-borne pathogen transmission. *Front Physiol* 3:64
- Fandamu P, Duchateau L, Speybroeck N, Marcotty T, Mbao V, Mtambo J, ... Berkvens D (2005) Theileria parva seroprevalence in traditionally kept cattle in southern Zambia and El Niño. *Int J Parasitol* 35(4):391–396
- FAO/UNESCO (1970) Key to soil units for the soil map of the world. Soil re-sources. Development and Conservation Service, FAO, Rome
- Field CB, Barros V, Stocker TF, Dahe Q (2012) Managing the risks of extreme events and disasters to advance climate change adaptation: special report of the intergovernmental panel on climate change. Cambridge University Press, New York
- Gasse F (2000) Hydrological changes in the African tropics since the last glacial maximum. *Quat Sci Rev* 19(1–5):189–211
- Gaughan JB, Mader TL, Holt SM, Josey MJ, Rowan KJ (1999) Heat tolerance of Boran and Tuli crossbred steers. *J Anim Sci* 77:2398–2405



- Halliwell B, Gutteridge JM (1990) Role of free radicals and catalytic metal ions in human disease: an overview. *Methods Enzymol* 186:1–85
- Heaney A, Little E, Ng S, Shaman J (2016) Meteorological variability and infectious disease in Central Africa: a review of meteorological data quality. *Ann N Y Acad Sci* 1382(1):31–43. <https://doi.org/10.1111/nyas.13090>
- Hiko A, Malicha G (2016) Climate change and animal health risk', climate change and the 2030 corporate agenda for sustainable development. *Advances in sustainability and environmental justice*, vol 19. Emerald Group Publishing Limited, Bingley, West Yorkshire, England, United Kingdom
- Hughes L (2003) Climate change and Australia: trends, projections and impacts. *Austral Ecol* 28(4):423–443
- Ivers CL, Ryan ET (2006) Infectious diseases of severe weather-related and flood-related natural disasters. *Curr Opin Infect Dis* 19:408–414
- Koelle K, Pascual M, Md Yunus (2005) Pathogen adaptation to seasonal forcing and climate change. *Proc Roy Soc Lond Biol Sci* 272(1566):971–977
- Krauer F, Riesen M, Reveiz L, Oladapo OT, Martínez-Vega R, Porgo TV, Höfliger A, Broutet NJ, Low N (2016) Zika virus infection as a cause of congenital brain abnormalities and Guillain-Barré syndrome: systematic review: DATASET
- Lacetera N (2019) Impact of climate change on animal health and welfare. *Anim Front* 9(1):26–31
- Leal B, Thomas DB, Dearth RK (2018) Population dynamics of off-host *Rhipicephalus* (Boophilus) microplus (Acari: Ixodidae) larvae in response to habitat and seasonality in South Texas. *Vet Sci* 5(2):33
- Lowen AC, Mubareka S, Steel J, Palese P (2007) Influenza virus transmission is dependent on relative humidity and temperature. *PLoS Pathol* 3(10):e151
- Mariner JC, House JA, Mebus CA, Sollod AE, Chibeu D, Jones BA, Roeder PL, Admassu B, Van't Klooster GGM (2012) Rinderpest eradication: appropriate technology and social innovations. *Science* 337(6100):1309–1312. <https://doi.org/10.1126/science.1223805>
- Mattioli RC, Pandey VS, Murray M, Fitzpatrick JL (2000) Immunogenetic influences on tick resistance in African cattle with particular reference to trypanotolerant N'Dama (*Bos taurus*) and trypanosusceptible Gobra zebu (*Bos indicus*) cattle. *Acta Trop* 75(3):263–277
- McDermott JJ, Kristjanson PM, Kruska R, Reid RS, Robinson TP, Coleman P, . . . Thornton PK (2002) Effects of climate, human population and socio-economic changes on tsetse-transmitted trypanosomiasis to 2050. In: *The African trypanosomes*. Springer, Boston, Massachusetts, USA. pp 25–38
- McLeman R, Hunter L (2010) Migration in the context of vulnerability and adaptation to climate change: insights from analogues. *Wiley Interdiscip Rev Clim Chang* 1:450–461
- Mellor P, Leake C (2000) Climatic and geographic influences on arboviral infections and vectors. *Rev Sci Tech-Off Int Epizooties* 19(1):41–48
- New M, Hewitson B, Stephenson DB, Tsiga A, Kruger A, Manhique A, Gomez B, Coelho CAS, Masisi DN, Kululanga E, Mbambalala E, Adesina F, Saleh H, Kanyanga J, Adosi J, Bulane L, Fortunata L, Mdoka ML, Lajoie R (2006) Evidence of trends in daily climate extremes over Southern and West Africa. *J Geophys Res* 111:D14102. <https://doi.org/10.1029/2005JD006289>
- Norval RAI, Sutherst RW, Kurki J, Gibson JD, Kerr JD (1988) The effect of the brown ear-tick *Rhipicephalus appendiculatus* on the growth of Sanga and European Breed cattle. *Vet Parasitol* 30(2):149–164
- Nyamushamba GB, Mapiye C, Tada O, Halimani TE, Muchenje V (2017) Conservation of indigenous cattle genetic resources in Southern Africa's smallholder areas: turning threats into opportunities – a review. *Asian-Australas J Anim Sci* 30(5):603–621. <https://doi.org/10.5713/ajas.16.0024>
- Pathiratne A, Jayasinghe RPPK (2001) Environmental influence on the occurrence of epizootic ulcerative syndrome (EUS) in freshwater fish in the Bellanwila-Attdiya wetlands, Sri Lanka. *J Appl Ichthyol* 17:30–40

- Rich KM, Roland-Holst D, Otte J (2014) An assessment of the *ex-post* socio-economic impacts of global rinderpest eradication: methodological issues and applications to rinderpest control programs in Chad and India. *Food Policy* 44:248–261. <https://doi.org/10.1016/j.foodpol.2013.09.018>
- Sang R, Kioko E, Lutomiah J, Warigia M, Ochieng C, O’Guinn M, ... Hoel D (2010) Rift Valley fever virus epidemic in Kenya, 2006/2007: the entomologic investigations. *Am J Trop Med Hyg* 83(2\_Suppl):28–37
- Scarpa R, Ruto ESK, Kristjanson P, Radeny M, Drucker AG, Rege JEO (2003) Valuing indigenous cattle breeds in Kenya: an empirical comparison of stated and revealed preference value estimates. *Ecol Econ* 45(3):409–426. [https://doi.org/10.1016/S0921-8009\(03\)00094-6](https://doi.org/10.1016/S0921-8009(03)00094-6)
- Siebert A (2014) Hydroclimate extremes in Africa: variability, observations and modeled projections. *Geography Compass* 8(6):351–367
- Songse MM, Hang’ombe MB, Phiri H, Mwase M, Choongo K, van der Waal B, Kanchanathan S, Reantaso MB, Subasinghe RP (2011) Field observations of fish species susceptible to epizootic ulcerative syndrome in the Zambezi River basin in Sesheke District, Zambia. *Trop Anim Health Prod* 44:179–183
- Steinfeld H, Wassenaar T, Jutzi S (2006) Livestock production systems in developing countries: status, drivers, trends. *Rev Sci Tech* 25(2):505–516
- Tanaka M, Kamiya Y, Kamiya M, Nakai Y (2007) Effect of high environmental temperatures on ascorbic acid, sulfhydryl residue and oxidized lipid concentrations in plasma of dairy cows. *Anim Sci J* 78(3):301–306. <https://doi.org/10.1111/j.1740-0929.2007.00439.x>
- Thornton PK, Herrero MT, Freeman H, Okeyo Mwai A, Rege J, Jones PG, McDermott JJ (2007). Vulnerability, climate change and livestock-opportunities and challenges for the poor. International Crops Research Institute for the Semi-Arid Tropics (ICRISAT), Patancheru, Hyderabad, India
- Thornton PK, van de Steeg J, Notenbaert A, Herrero M (2009) The impacts of climate change on livestock and livestock systems in developing countries: a review of what we know and what we need to know. *Agric Syst* 101(3):113–127
- Van den Bossche P, Coetzer J (2008) Climate change and animal health in Africa. *Rev Sci Tech* 27(2):551–562
- van Dijk J, Sargison ND, Kenyon F, Skuce PJ (2010) Climate change and infectious disease: helminthological challenges to farmed ruminants in temperate regions. *Int J Anim Biosci* 4(3):377–392. <https://doi.org/10.1017/S1751731109990991>
- Young BA (1993) Implications of excessive heat load to the welfare of cattle in feedlots. In: Recent advances in animal nutrition, Armidale, Australia. Animal Science, Armidale, pp 45–50
- Zougmore R, Partey S, Ouédraogo M, Omitoyin B, Thomas T, Ayantunde A, ... Jalloh A (2016) Toward climate-smart agriculture in West Africa: a review of climate change impacts, adaptation strategies and policy developments for the livestock, fishery and crop production sectors. *Agric Food Sec* 5(1):26

**Open Access** This chapter is licensed under the terms of the Creative Commons Attribution 4.0 International License (<http://creativecommons.org/licenses/by/4.0/>), which permits use, sharing, adaptation, distribution and reproduction in any medium or format, as long as you give appropriate credit to the original author(s) and the source, provide a link to the Creative Commons license and indicate if changes were made.

The images or other third party material in this chapter are included in the chapter’s Creative Commons license, unless indicated otherwise in a credit line to the material. If material is not included in the chapter’s Creative Commons license and your intended use is not permitted by statutory regulation or exceeds the permitted use, you will need to obtain permission directly from the copyright holder.





# Livestock Breeders' Adaptation to Climate Variability and Change in Morocco's Arid Rangelands

# 91

Wadii Snaibi and Abdelhamid Mezrhah

## Contents

Introduction .....	1854
Materials and Methods .....	1857
Study Area .....	1857
Data Collection .....	1857
Data Analysis .....	1858
Results and Discussion .....	1859
Socioeconomic Characteristics of Breeders Surveyed .....	1859
Analysis of Pastoralists Adaptation Practices in the HPEM .....	1859
Differentiation of Adaptation Measures According to Breeders' Classes .....	1861
Factors Influencing the Adoption of Climate Change Adaptation Practices .....	1864
Conclusion .....	1869
References .....	1869

## Abstract

Since the mid-1970s, the high plateaus of eastern Morocco have experienced proven trends of climate change (CC) such as a significant decrease in rainfall amounts and an increase in the droughts' frequency. Consequently, the CC threatens the sustainability of this pastoral ecosystem and negatively affects the

This chapter was previously published non-open access with exclusive rights reserved by the Publisher. It has been changed retrospectively to open access under a CC BY 4.0 license and the copyright holder is "The Author(s)". For further details, please see the license information at the end of the chapter.

W. Snaibi (✉)

Laboratory Communication, Education, Digital Usage and Creativity, ETIGGE Research Team, Bd. Mohammed VI, University Complex, Mohammed Premier Oujda University, Oujda, Morocco  
National Institute of the Agronomic Research of Morocco, CRRA of Oujda, Oujda, Morocco

A. Mezrhah

Laboratory Communication, Education, Digital Usage and Creativity, ETIGGE Research Team, Bd. Mohammed VI, University Complex, Mohammed Premier Oujda University, Oujda, Morocco

© The Author(s) 2021

1853

W. Leal Filho et al. (eds.), *African Handbook of Climate Change Adaptation*,  
[https://doi.org/10.1007/978-3-030-45106-6\\_18](https://doi.org/10.1007/978-3-030-45106-6_18)

breeding of small ruminants, the main local-level livelihood, which becomes more vulnerable due to its high dependence on climatic conditions. This chapter aims to analyze breeders' adaptation practices by taking into account their social stratification based on the size of the sheep flock in possession. Data were analyzed using descriptive statistics, Kruskal-Wallis and Mann-Whitney tests to examine the differences in the adoption' frequency of CC adaptation measures according breeders' classes and Chi-square independence test to identify the factors explaining these observed differences. The analysis of local adaptation practices reveals that they are endogenous but above all curative, aiming at a short-term logic and have a low to medium relevance compared to the specific objective of adaptation to CC. In addition, there are significant differences in the frequency of adoption of CC adaptation strategies (chi-square value = 8.1112,  $p = 0.017$ ,  $df = 2$ ) within categories of breeders, in particular between small and larger breeders (U statistic = 58.000,  $p = 0.008$ ). The significant factors explaining these differences are socioeconomic (age, household size, equipment, training, and membership of a basic professional organization). It is therefore recommended to target small breeders as a priority and to set up support measures (equipment, training, funding, organization of breeders).

---

**Keywords**

Climate change · Adaptation · Pastoralists · Arid rangelands · Morocco

---

**Introduction**

Currently, climate change (CC) has become obvious, due to its manifold effects on human and natural systems, affecting all countries of the world (IPCC 2014). Africa is considered one of the most vulnerable continents to climate change and extreme events (Garcia 2008). This vulnerability is principally attributed to the low level of economic development in its countries, thus generating a weak and limited adaptive capacity to deal with the negative physical, human, and socioeconomic impacts of CC (Besada and Sewankambo 2009; Bruckner 2012).

Within North African countries, Morocco is seen as the most vulnerable to climatic change and extremes, due to the combination of high exposure to climate consequences, marked climate sensitivity (high dependency on rain-fed agriculture, recurrent water stress), and a weak generic adaptive capacity (low income per capita and its unequal distribution) (Yohe et al. 2006; Schilling et al. 2012). Indeed, Morocco has already suffered the impacts of climate change, evidenced by the climate trends observed during the period from 1960 to 2005. Thus, aridity has increased from the south to the north of the country (Mokssit 2012), rainfall had seen a widespread decline (Schilling et al. 2012) of between 3% and 30% (Ezouine and Bouaza 2019), while the temperature has risen (Hulme et al. 2001) from 1.0 to more than 1.8 °C (Morocco 2016). In addition, the frequency, intensity and duration of droughts have increased during the last three decades (Moroccan Meteorological

Office 2007; NIC 2009). Climate change projections for Morocco, exhibit a decrease in annual rainfall amounts of 10–20% by 2100 (Mokssit 2012; Morocco 2016) and an increase in temperature until 2050 between 1.0 °C to 1.2 °C (Schilling et al. 2012) or ranging from 2 °C to 3 °C according to Paeth et al. (2009). Also, the frequency and the duration of droughts are forecasted to rise (Beniston et al. 2007; Bzioui 2012; Schilling et al. 2012). In short, negative climatic changes already observed are likely to continue in the twenty-first century, resulting in warmer and drier conditions (Schilling et al. 2012). Agriculture, the key economic sector and the main provider of jobs, is the most negatively affected by the effects of CC (Morocco 2016). Thereby, rural populations whose rain-fed agriculture is the major source of income are hardest hit because of their high vulnerability to the harmful consequences of climate change (Morocco 2011).

In this context, the study area, namely, the high plateaus of eastern Morocco (HPEM), has experienced proven climate change trends since the late 1970s, such as a substantial decrease in rainfall (Fink et al. 2010; François et al. 2016; Melhaoui et al. 2018) and an increase in temperature and frequency of droughts (Moroccan Meteorological Office 2007; François et al. 2016; Melhaoui et al. 2018). Livestock breeding on rangelands, based mostly on the sheep farming, is the main livelihood and job provider for the local population. This economic activity is vulnerable to CC due to its high dependence on climatic conditions (Bechchari et al. 2014), which are characterized by high intra- and inter-annual variability in rainfall and recurrent droughts (Mahyou et al. 2010; Bechchari et al. 2014). In fact, livestock breeding on arid rangelands is severely affected by the adverse impacts of extreme climate change events since it depends on natural resources and practiced in a fragile and marginal environment such as the pastoral ecosystem of the study area. As highlighted by Hassan (2010) drylands present an intrinsic natural vulnerability generated by a high exposure to significant water stress. Indeed, climate change and extremes in the high plateaus of eastern Morocco threatened the sustainability of pastoral livestock rearing, accentuated the precariousness of the poorest rural households and increased the flow of potential emigrants. Also, extreme climatic events (drought in particular), that have occurred in the HPEM in the past, have caused fodder and water scarcities leading to higher competition for available natural resources and to sometimes brutal pastoral conflicts (Bourbouze and El Aich 2000).

The increase in the occurrence and intensity of climate change-induced droughts and their prolongation over time exacerbated social inequalities among local breeders (Schilling et al. 2012). Indeed, at the time of drought event, small-scale livestock owners face both increased pressure on available pastoral resources and an inability to purchase higher-priced livestock feeds. Thereafter, the size of their herds decreases considerably, while large breeders, their strategy of decapitalization seems to be well under control and their ability to replenish herds is much greater (Bourbouze 2000; Bechchari et al. 2014). In fact, better-off herders are slightly less vulnerable because they are not exclusively or largely dependent on natural resources, have the financial resources to buy livestock feed, and can even take advantage of this opportunity created by the decapitalization of the poorest livestock owners (Kuhn et al. 2010; Bechchari et al. 2014).

In addition, decrease in rainfall and increased droughts' frequency have contributed to the degradation of rangelands in the HPEM, which has also been caused by overgrazing, plowing and anarchic cultivation of marginal areas, uncontrolled land clearing and sedentarization (Mahyou et al. 2010; Maâtougui et al. 2011; Schilling et al. 2012). Furthermore, climate change and extreme weather events, especially, have often limited the success and sustainability of local public interventions in terms of development and poverty reduction.

To deal with or overcome the negative impacts of climate variability and change, livestock herders in the HPEM have undertaken a diversified range of coping and adaptation practices such as pastoral mobility (transhumance), reciprocal grazing agreements with distant pastoral tribes, rearing of mixed species herds, social networks, and intracommunity solidarity to mitigate income shocks (Bourbouze 2000; Bourbouze and El Aich 2000; Schilling et al. 2012). Complementing these traditional coping actions, contemporary adaptation strategies, which are widely implemented in the study area, include: association of cereal crops and livestock farming, breeding of mixed herds of sheep and goats, new form of mobility based on motorization, income diversification and use of emigrants' remittances, commercializing of livestock, storage of livestock feed, using subsidized livestock feed and public programs against drought effects, sale of animals to purchase supplementary livestock feed (Bourbouze 2000; Bourbouze and El Aich 2000; Schilling et al. 2012), and recently the subscription to insurance climatic multi-risks which covers land cultivated with cereals, but not mobile or sedentary livestock rearing.

Nevertheless, these adaptation strategies are in large part of curative scope, low efficient and are less sustainable over time (Bourbouze 2000; Bourbouze and El Aich 2000). In addition, many of these adaptive practices show a relative or low relevance regarding to the specific objective of adapting to climate change and extremes, since they are seen rather as alternative livelihoods more than adaptation actions itself. Thus, they are undertaken by some breeders in order to secure or diversify their livelihoods, for instance, casual work, emigration and the practice of income-generating activities in complement to livestock rearing.

In addition, the adaptive capacity of the herders in the HPEM's area to climate variability and changes depends on the size of the livestock held and the financial and material resources available. So, their adaptive behaviors rely on their respective socioeconomic status (Bechchari et al. 2014). Thereby, small-scale breeders have less options for adaptation, are more severely affected by the observed adverse climatic trends, and are more threatened by the abandonment of livestock rearing (Bourbouze 2000). More globally, Lazarev (2008) pointed out that the main criteria for differentiation between categories of breeders in the study area are socioeconomic characteristics such as the size of the herd exploited and the capital available. Similarly, it is accepted that the susceptibility to the effects of CC and the adaptation capacities differ according to the farmers. In fact, since that the farmers' CC adaptation depends on their respective specific socioeconomic conditions (Below et al. 2012), the design of an effective and appropriate adaptation CC policy and strategies, must take into consideration these differences within human contexts (Fussel 2007) by using local-level analyses (Below et al. 2012).

In view of all of the above, the study is aimed at filling the knowledge gaps relating to the adaptation of breeders in the study area to CC, mainly with regard to the effect of social differentiation within livestock herders on the adoption (implementation) of adaptation strategies to this phenomenon. Concretely, the specific objective is to analyze breeders' practices in adapting to climate variability and change, by taking into account their contrasting socioeconomic conditions mainly the existing differences in the size of the sheep flock in ownership.

---

## Materials and Methods

### Study Area

Located in the northeast of the country (30S UTM zone), the high plateaus of eastern Morocco (HPEM) are one of the largest pastoral areas in Morocco, covering about 3.5 million hectares. Their soils are generally shallow, low in organic matter and therefore susceptible to wind and water erosion (Mahyou et al. 2016). Water resources are very limited. The HPEM have two gradients going from north to south: the altitude increases regularly from 900 to 1400 m and the climate fluctuates from semi-arid to lower arid and pre-Saharan. Indeed, the climate is of Mediterranean type, but under of a great influence of the Sahara. Average annual rainfall is highly variable, ranging from 143 mm in the south to 201 mm in the north, with respective coefficients of variation of 45% and 34% (Melhaoui et al. 2018). Dry and hot winds which can cause real sandstorms, especially in summer, are frequent. The rangelands of the HPEM are dominated by specific steppe vegetation consisting of steppes at *Stipa tenacissima*, Chamemic steppes at *Artemisia herba alba* and steppes at Chenopodiaceae (*Artrophytum scoparium*). The vast majority of local population derive most of their income from livestock farming, in particular sheep breeding. The herds in the possession of the breeders in the study area are made up of more than two million heads of small ruminants, usually conducted according to an extensive to semi-extensive rearing system. The HPEM area can be seen as a suitable and representative site for better understanding of adaptation to CC in Morocco's pastoral ecosystems.

### Data Collection

Data collection method consisted of a literature review and a survey of 167 breeders, heads of pastoralist households. Relevant literature available from local extension and agricultural development agencies were consulted to acquire a complete and clear overview about the CC issue in the HPEM's area, mainly with regard to livestock practices and core endogenous adaptation measures implemented by the breeders in response to climate variability and change. The survey of herders focused on the socioeconomic characteristics of households and the adaptation practices embraced to reduce the effects of perceived CC. The basic study unit is the

pastoralist household, as at this level, decisions relating to adaptation to climate variability and change are taken (Below et al. 2012).

Given that sheep farming is the main activity of the pastoralist households in the study area, the size of the sheep flock in ownership was chosen as the criterion of discrimination between herders. Thereby, three classes of livestock breeders have been identified and this in agreement with local agricultural extension agencies. Large breeders are those with a sheep herd exceeding 300 heads, medium breeders with own sheep flocks of between 101 and 300 heads and the small livestock owners with the number of sheep in possession is less than or equal to 100 heads. Based on the respective representativeness of these three breeders' categories in the study area (Bechchari et al. 2014), respondent herders were randomly selected. The distribution of breeders surveyed by class is as follows: 96 small, 47 medium, and 24 large breeders to give a total of 167 livestock producers.

## Data Analysis

Data collected on the adaptation practices implemented by the livestock herders in the study area were analyzed using descriptive statistics and the tests of Kruskal-Wallis, Mann-Whitney U and of Chi-square independence. Descriptive statistics have been made, with regard to the socioeconomic characteristics of breeders surveyed and the different local adaptation measures. The Chi-square independence test was used to highlight the relationship that may exist between the developed endogenous practices and the categories of herders (small, medium, large). In addition, the strength of this possible statistical association was measured using Cramer's V coefficient. This test was also carried out to verify whether the observed differences within the three breeders' classes is linked to their respective socioeconomic conditions at household level. Furthermore, Kruskal-Wallis test is an appropriate nonparametric test for comparing more than two independent samples. It is a rank-based test which can be used to test whether such samples come from the same distribution (Ostertagova et al. 2014). The null hypothesis is the following: all the populations have the same median or no significant difference between the groups (samples). In our case, the Kruskal-Wallis test was used to testing for difference in the frequency of adoption of adaptation strategies among three livestock breeders' classes. If the Kruskal-Wallis statistic is significant, a nonparametric multiple comparison method (Mann-Whitney U test) is used to find out which classes of herders are different from the others. Also, using the Mann-Whitney U test, we assessed if the adoption of adaptation practices to CC differed significantly between the three classes of breeders which are based on the size of the owned sheep herd. Indeed, this test was realized to show if there is a significant difference between the "adoptive" and "non-adoptive" groups according to the number of sheep in possession. Generally, the Mann-Whitney U test is a non-parametric statistical test used to determine if two independent samples come from the same population or from 2 different populations. Indeed, this test was used because the assumptions of use of the Student's t test were not verified (non-comparable variances and non-normal distribution of the dependent variable).



## Results and Discussion

### Socioeconomic Characteristics of Breeders Surveyed

The average age of breeders is 52 years with almost 60% of them who have an age greater than or equal to 50 years. Livestock breeders are in large part without level of education (70%). The rearing of small ruminants is the main economic activity for 83% of herders sampled. Approximately 35% of respondents are engaged in an ancillary activity (mainly the temporary employment: 26%). The size of households is an average of 8 people. The average number of labor force by household is around 2 persons. The employ of shepherds is observed in 36% of cases. The rate of emigration is low and is close to 17%. The types of dominant habitat are the tents and concrete houses with respectively 36% and 24%. The rate of connection to the public electricity network is low, either almost 20%. The distance to the nearest market is relatively long and is 60 km.

The majority of the breeders (83%) had agricultural land, but only 16% of the herders surveyed owned an irrigated plot. In effect, on average, arable land was about 31 ha and irrigated area did not exceed the 0.37 ha. Breeders are moderately equipped, since more than 61% of them possesses at least one agricultural equipment and/or transport (possession trucks: 27%, tractors: 14% and water tanks: 50%). The average number of sheep and goats are respectively of 166 and 33 heads/breeder. More than 52% of the herders have at least one head of bovine cattle.

Access to formal credit is low not exceeding 23%.

### Analysis of Pastoralists Adaptation Practices in the HPEM

Table 1 showed that the breeders in the HPEM have implemented, over time, a wide and diversified range of adaptation practices to cope with the harmful effects of hazards and climate changes.

These adaptation and coping measures are almost all of endogenous origin, thus attesting on a great intrinsic capacity for adaptation based on the accumulation of experiences and initiatives of the breeders in this arid pastoral ecosystem where climatic conditions are difficult and unpredictable. Local adaptation practices to climate variability and change can be grouped into two main categories: (1) Adjustment of farm management and pastoral practices and (2) Partial shift to alternative livelihood options. A large part of the adaptation actions identified concerns the first dimension.

Contemporary adaptive strategies in the study area are mostly individualized. This testifies to the spectacular rise of an individualism of spirit and action and of refocusing on the individual to the detriment of the social group to which he belongs (Bourbouze and El Aich 2000). These authors added that it is now at the individual level that one must know how to protect oneself from environmental and economic risks and no longer at the community level. Whereas during the first half of the last century, local customary institutions organized the access and use of collective

**Table 1** Distribution of herders surveyed according to adaptive measures implemented (in %)

Adaptation practices	Freq.	Perc.	Dur.	Inten.	Adeq.
(1) Adjustment of farm management and pastoral practices					
Mixed livestock crop farming system	139	83.2	LT	P	M
Profit of state agricultural programs	132	79	ST	C	M
Diversification of livestock species	130	77.8	LT	P	M
Climate multi hazard insurance	80	47.9	ST	C	H
Storage of animal feed	80	47.9	ST	C	H
Herd mobility	67	40.1	ST	C	H
Regular Sale of animals to stock up on feed	79	47.3	ST	C	L
Sale of the animal in a good physical state	73	43.7	LT	P	M
Practice of fattening	51	30.5	ST	C	M
Credit from speculators livestock feed	37	22.2	ST	C	L
Privative appropriation of rangelands	30	18	ST	C	M
Irrigated agriculture and livestock integration	22	13.2	LT	P	H
(2) Partial shift to alternative livelihood options					
Conversion of livestock capital into land capital	67	40.1	LT	P	L
Casual labor	55	32.9	ST	C	L
Internal or external emigration in search of jobs	28	16.8	LT	P	L
Collection of truffles as additional income	14	8.4	ST	C	L

Freq.: Frequency. Perc.: Percentage. Duration: ST (Short term); LT (Long term). Intention: C (Curative action); P (Preventive action). Adequacy: H: High; M: Medium; L: Low

pastoral resources and guaranteed intra- and inter-tribal solidarity for the survival of their ethnic groups in times of climate crisis. The decline of these traditional structures for several decades has been caused mainly by a public policy which has fragmented tribal organizations in favor of modern administrative and elected institutions and encouraged sedentarization (Rachik 2007). Negative practices of breeders, especially the large and influential among them, such as the cultivation of rangelands and their appropriation for private use, have also contributed to the weakening of these tribal structures (Bourbouze 2000; Bechchari et al. 2014).

In addition, the majority of the adaptation measures adopted are part of a short-term temporal perspective, thus allowing breeders to buffer climate risks and reduce their negative consequences through the practices of curative type (for example the regular sale of animals to purchase livestock feed, benefit from public interventions such as subsidized fodder). This testifies to the predominance of short-term and reactive vision of adaptation at local level. Furthermore, most local adaptive practices show a low to medium adequacy in relation to the main objective of adaptation to CC, as their purpose is not a specific response to this phenomenon. They are embraced by breeders either to improve their rearing productivity and, thus, contribute to reducing their vulnerability to hazards and hostile climatic changes, such as diversification of livestock species and practice of fattening (medium adequacy) or to increase their income, meet the financial needs of their farms and maintain their economic activity, e.g., regular sale of animals to purchase livestock feed, credit from resellers of livestock feed and casual employment (low adequacy). Only four

adaptation measures which were highly relevant in relation to climate change. They are: transhumance or herd mobility, storage of livestock feeds, subscription to climate insurance and the integration of livestock breeding and irrigated agriculture. However, these adaptive actions depend on the socioeconomic status of the breeder (mostly implemented by large herders) or they are very spatially localized like irrigated agriculture.

In line with our findings, Bourbouze (2000) and Bourbouze and El Aich (2000) highlighted that most adaptation practices to variability and climatic risks (drought in particular) implemented by the breeders in the HPEM are of curative type and provide only relative protection. The only really effective strategies against climatic hazards were the cereal-livestock association, livestock feed supplements purchased through animal sales, remittances of emigrants and irrigated agriculture by pumping, but even these are little effective in a sustainable way. Bechchari et al. (2014) emphasized that the adaptive capacity of herders in the HPEM's area with regard to climate-related risks and changes, closely depends on their respective socioeconomic characteristics. In fact, the socioeconomic status of breeders in the study area largely affects their drought adaptation responses and more generally their pastoral practices and their way of using the rangelands (Mahdi 2007; Lazarev 2008).

## **Differentiation of Adaptation Measures According to Breeders' Classes**

The Table 2 showed general divergence in the frequencies of adaptation measures implemented within the categories of breeders (small, medium and large) which are based on the size of the sheep flock in ownership. Thus, large livestock owners adopt with higher frequencies, most of the endogenous adaptation practices in response to perceived climate variability and change, compared to the two other categories. In addition, practices of the first dimension of adaptation measures are more frequently implemented by large breeders. They include strategies for the diversification of the productions (integration of livestock breeding and cereal farming, breeding of mixed flocks of sheep and goats), improvement of rearing productivity (practice of the fattening, selection and reproduction of powerful races), transhumance and market orientation (finished products of good taste quality). In fact, all of these adaptation strategies require considerable financial resources, which manifests itself in much lower adoption frequencies among small and medium-sized breeders.

By relying on their social status and their relationship networks, large breeders adopt an opportunistic land strategy by constantly conquering vast new areas of collective rangelands for their private use. As evidenced by the significant differences between the average available agricultural areas, which are 86, 37 and 15 hectares respectively for great, medium and small breeders. Recently, large herders and some medium breeders have massively subscribed to climatic multi-risk insurance. The adoption of this practice has two objectives. First, climate insurance contracts represent, in the eyes of local breeders, justifications approving the legitimacy of the ownership of conquered rangelands in order to annex them definitively

**Table 2** Frequencies of adaptation measures in percentage according to breeders' classes and results of the Chi-square independence test

Adaptation practices	Small (n = 96)	Medium (n = 47)	Large (n = 24)	$\chi^2$ Pearson	Cramer's V
Mixed livestock crop farming system <sup>a</sup>	74	93.6	100	14.384 (0.001)	0.293 <sup>M</sup>
Profit of state agricultural programs	75	83	87.5	2.423 (0.298)	0.120 <sup>L</sup>
Diversification of livestock species	71.9	85.1	87.5	4.718 (0.095)	0.168 <sup>L</sup>
Climate multi hazard insurance <sup>a</sup>	28.1	70.2	83.3	36.493 (0.000)	0.467 <sup>S</sup>
Storage of animal feed <sup>a</sup>	36.5	63.8	62.5	11.865 (0.003)	0.267 <sup>M</sup>
Herd mobility <sup>a</sup>	27.1	48.9	75	20.466 (0.000)	0.350 <sup>M</sup>
Regular Sale of animals to stock up on feed	44.8	53.2	45.8	0.917 (0.632)	0.074 <sup>L</sup>
Sale of the animal in a good physical state <sup>a</sup>	33.3	48.9	75	14.273 (0.001)	0.292 <sup>M</sup>
Practice of fattening <sup>a</sup>	20.8	31.9	66.7	19.072 (0.000)	0.338 <sup>M</sup>
Credit from speculators livestock feed <sup>a</sup>	18.8	19.1	41.7	6.189 (0.045)	0.193 <sup>L</sup>
Privative appropriation of rangelands <sup>a</sup>	13.5	17	37.5	7.518 (0.023)	0.212 <sup>M</sup>
Irrigated agriculture and livestock integration	8.3	21.3	16.7	4.920 (0.085)	0.172 <sup>L</sup>
Conversion of livestock capital into land capital <sup>a</sup>	29.2	44.7	75	17.355 (0.000)	0.322 <sup>M</sup>
Casual labor <sup>a</sup>	42.7	27.7	4.2	13.736 (0.001)	0.287 <sup>M</sup>
Internal or external emigration in search of jobs	13.5	21.3	20.8	1.685 (0.431)	0.100 <sup>L</sup>
Collection of truffles as additional income <sup>a</sup>	13.5	2.1	0	7.917 (0.019)	0.218 <sup>M</sup>

Note: Cramer's V. value: S: Strong (between 0.40 and 0.80); M: Moderate (between 0.20 and 0.40); L: Low (between 0.10 and 0.20). Values in parentheses in  $\chi^2$  Pearson represent the asymptotic significance (bilateral)

<sup>a</sup>Significant at 5% level

later. Also, this measure (insurance) allows subscribers significant financial compensation following of climatic hazards (drought in particular) equals to 600 MAD per hectare.

Large livestock owners have benefited from contracts of sale with supermarkets of many urban agglomerations in the north of the country during the feasts of sacrifice, thanks to the USAID' initiative. Thus, they were able to achieve very interesting butcher performances (well-finished animal products with appreciable gustative qualities). This explains the strong orientation of their breeding

activity towards the market. In addition, thanks to their accumulated savings, large livestock keepers invest more and more in activities of speculation, including the real estate, in order to overcome the unfavorable climatic and economic conditions affecting their livestock rearing activity.

As for small herders, they frequently shift to additional off-farm livelihoods to complete or diversify their income sources. Thus, they are forced to engage in other small-scale activities in addition to the livestock breeding, such as temporary labor, collecting truffles and small trades, in order to satisfy both the needs of their families and those of their meager herds especially in the event of climatic vagaries (drought) prolonged in time. The poorest of them, after the sale of all their herds, find themselves decapitalized. In the absence of support from relatives or the State, they opt for rural exodus as the final solution.

In addition, the results of the Chi-square independence test revealed that there was a statistically significant relationship between most adaptation practices (11/16 measures identified) and livestock breeders' classes (Table 2). The Cramer's V coefficient measuring the strength of this statistical relationship has medium to high values. This association of significant magnitude indicates, thereby, that the larger the size of the sheep herd in possession, the higher the frequency of adoption (implementation) of adaptation practices.

As highlighted by Bourbouze (2000), the choices for small breeders regarding adaptation to adverse impacts of climate variability and extremes are much narrower and their most common strategy is to regularly sell animals in the souk so that they can buy livestock feed, water their herds and feed their families. Thereafter, either they abandon livestock rearing after having sold all their flocks, or they migrate to the nearest urban centers in search of small trades. Whereas the decapitalization strategy seems well controlled among large breeders (Bourbouze and El Aich 2000), they can even take advantage of periods of climatic crisis to increase the size of their herds to the detriment of the poorest breeders (Schilling et al. 2012). Bechchari et al. (2014) underlined that the portfolio of strategies for adapting to variability and climate change implemented by large breeders is much denser and more diversified. It includes the acquisition of equipment (trucks, tractors, water tanks), the appropriation of large areas of rangelands, the profit of the best grazing sites and the commercial speculation in livestock in order to make a good profit on their invested capitals. In contrast, the possibilities offered for small breeders, are very limited and mainly boil down to the regular sale of their herds, the search for additional activities to breeding and rural exodus.

The Kruskal-Wallis test was conducted to examine the differences in the frequency of adoption of climate change adaptation practices according to the classes of breeders. Significant differences (chi square = 8.1123,  $p = 0.017$ ,  $df = 2$ ) were found between the three categories of herders. In addition, the distribution of the majority of adaptive measures differs significantly between classes of breeders (Table 3).

After the Kruskal-Wallis test led us to reject the null hypothesis of similarity between breeders' categories in terms of frequency of adoption of adaptation and coping actions, we performed pairwise comparisons using the Mann-Whitney test to

**Table 3** Results of the Kruskal-Wallis test

Adaptation practices	Chi-square value	Sig-p
Mixed livestock crop farming system**	14.298	0.001
Profit of state agricultural programs	2.408	0.300
Diversification of livestock species	4.690	0.096
Climate multi hazard insurance***	36.275	0.000
Storage of animal feed**	11.794	0.003
Herd mobility***	20.344	0.000
Regular Sale of animals to stock up on feed	0.912	0.634
Sale of the animal in a good physical state**	14.187	0.001
Practice of fattening***	18.958	0.000
Credit from speculators livestock feed*	6.152	0.046
Private appropriation of rangelands*	7.473	0.024
Irrigated agriculture and livestock integration	4.891	0.087
Conversion of livestock capital into land capital***	17.251	0.000
Casual labor**	13.654	0.001
Internal or external emigration in search of jobs	1.675	0.433
Collection of truffles as additional income*	7.869	0.020

Note: Significance: \*\*\* $P < 0.01$ , \*\* $P < 0.05$ , \* $P < 0.1$ ; Degree of freedom = 2

determine which classes of breeders are different. The results of this test show that there is a highly significant difference (U statistic = 58.000,  $p = 0.008$ ) between small and large breeders in adopting CC adaptation practices. The other differences between on the one hand small and medium breeders (U = 92.000,  $p = 0.174$ ) and between medium and large herders on the other hand (U = 79.500,  $p = 0.067$ ) were found not to be significant. This shows that breeders' adaptation in the study area depends mainly on their social status or economic power, expressed by the size of the sheep herd in possession.

### Factors Influencing the Adoption of Climate Change Adaptation Practices

In order to confirm this relationship between the adaptation measures to climate variability and change implemented by the breeders in the study area and the size of the sheep herd in possession, we carried out the Mann-Whitney U test. This test is often employed to compare differences between two independent groups when the dependent variable is continuous, but not normally distributed. In our case, the two independent groups are the "adopters" and "non-adopters" of CC adaptation practices, while the continuous dependent variable is the sheep herd size. The mean rank column shows mean rank for the two groups tested (adopters and non-adopters groups). This column is very useful because it indicates which group can be considered as having the higher size of sheep herd, overall; namely, the group with the highest mean rank. In this case, the adopter group had the highest size of sheep herd. Indeed, the first group (adopters) have higher mean ranks than those of

non-adopters, except for the case of two coping actions, namely, "Casual labor" and "Collection of truffles as additional income" (Table 4). In fact, these two practices are usually pursued either as a complement to a breeding activity that does not allow the household to meet its needs or in the event of abandonment of livestock farming (decapitalization frequently caused by successions of prolonged episodes of drought). They are practiced mainly by the small breeders with respectively 75 and 93%.

Furthermore, the Test Statistics column shows us the actual significance value of the Mann-Whitney U test. Specifically, this column provides the test statistic, U statistic, as well as the asymptotic significance p-value. From our data, it can be

**Table 4** Mann-Whitney U test showing the relationship between sheep herd size and adaptive practices

Adaptation practices	Mean rank		(U, <i>p</i> )	Z
	Yes	No		
Mixed livestock crop farming system	92.64	41.11	(745, 0.000)	-5.149
Profit of state agricultural programs	87.16	72.07	(1892.5, 0.100)	-1.643
Diversification of livestock species (sheep & goats)	90.33	61.76	(1582, 0.002)	-3.174
Climate multi hazard insurance	105.35	64.37	(1772, 0.000)	-5.476
Storage of animal feed	96.01	72.96	(2519.5, 0.002)	-3.079
Herd mobility	107.60	68.19	(1768.5, 0.000)	-5.168
Regular Sale of animals to stock up on feed	91.88	76.93	(2853.5, 0.046)	-1.997
Sale of the animal in a good physical state	100.18	71.44	(2250, 0.000)	-3.813
Practice of fattening	105.96	74.34	(1838, 0.000)	-3.895
Credit from speculators livestock feed	98.43	79.89	(1871, 0.039)	-2.059
Privative appropriation of rangelands	106.17	79.15	(1390, 0.006)	-2.774
Irrigated agriculture and livestock integration	97.68	81.92	(1294, 0.154)	-1.425
Conversion of livestock capital into land capital	101.54	72.25	(2174.5, 0.000)	-3.841
Casual labor	59.39	96.08	(1726.5, 0.000)	-4.612
Internal or external emigration in search of jobs	94.36	81.91	(1656, 0.214)	-1.243
Collection of truffles as additional income	27.46	89.17	(279.5, 0.000)	-4.574

Note: U: U statistic of Mann-Whitney test, *p*: the value of *p* of the test

concluded that the size of the sheep herd in the adopter group was significantly higher than in the non-adopter group for the majority of adaptation strategies practiced by the livestock owners in the study area.

In line with our findings, herd size influences positively and significantly the likelihood that pastoralists implement adaptation strategies in the face of climate change (Balew et al. 2014; Berhanu and Beyene 2015; Opiyo et al. 2015).

Other socioeconomic characteristics at household-level, using the category of the breeder as a classification variable, could explain significant observed differences in the frequency of climate change adaptation practice's adoption (implementation) within breeders' classes (small, medium, large). The results of chi-square independence test contained in the Table 5 show that there is a significant relationship between the category of herder and the following factors: age of breeder ( $\chi^2 = 19.020, p = 0.000$ ), household size ( $\chi^2 = 30.720, p = 0.000$ ), no practice of ancillary activity ( $\chi^2 = 25.662, p = 0.000$ ), employment of shepherds ( $\chi^2 = 42.124, p = 0.000$ ), land ownership ( $\chi^2 = 14.384, p = 0.001$ ), possession of truck ( $\chi^2 = 17.754, p = 0.000$ ), possession of tractor ( $\chi^2 = 49.740, p = 0.000$ ), possession of water tank ( $\chi^2 = 33.902, p = 0.000$ ), possession of a motor pump ( $\chi^2 = 39.048, p = 0.000$ ), veterinary care ( $\chi^2 = 16.005, p = 0.000$ ), training received ( $\chi^2 = 7.850, p = 0.020$ ) and membership to a technical supervisory structure, namely, National Association of sheep and goat breeders- ANOC ( $\chi^2 = 27.454, p = 0.000$ ).

Large livestock producers have a higher average age, 62 years, compared to 49 years for small breeders (Table 6). They are ones who benefited the most from training actions in livestock rearing, development and management of rangelands and other technical topics of interest (42% vs. 17%), adhered massively to the breeders' organization, namely, ANOC (58% vs. 11%). These elements indicate that large herders have accumulated a great pastoralism experience compared to small-scale breeders. Piya et al. (2013) and Tiwari et al. (2014) pointed out that the training received improved the adaptive capacity of farmers in the face of climate change. As highlighted by Tiwari et al. (2014) and Taruvinga et al. (2016), membership in the community-based organizations increases the adoption of climate change coping strategies. Yila and Resurreccion (2013) and Mabe et al. (2014) underlined that farming experience significantly and positively influences the implementation of CC measures, respectively in the semiarid Nguru Local Government Area, Northeastern Nigeria, and in Northern Ghana. In addition, large breeders are far largely more endowed with production factors than small breeders such as labor force (4 vs. 1 people), employment of shepherds (88 vs. 19%), land size (86 vs. 15 ha), small ruminants herd size (684 vs. 72 heads), bovine cattle flock size (7 vs. 1 head), number of equipment owned (5 vs. 1) and veterinary care (83 vs. 45%). In line with our findings, Yila and Resurreccion (2013) pointed out that labor force was a significant determinant for farmers' adaptation practices to climate change in the semiarid Nguru Local Government Area, Northeastern Nigeria. Debalke (2011) and Ndamani and Watanabe (2016) highlighted that land size was a determinant factor that influences farmers' climate change coping strategies, respectively, in north shoa zone of Amhara region Ethiopia and Lawra district of Ghana. Berhanu and Beyene (2015) and Opiyo et al. (2015) have found that herd size affected positively and



**Table 5** Significant factors (categorical variables) explaining the differences observed in the frequency of adoption of adaptation practices between categories of breeders

Categorical variables	Small (%)	Medium (%)	Large (%)	Chi-square value	Sig-p
Age				19.020	0.000
<50 years	54	32	8		
>=50 years	46	68	92		
Ancillary activity				25.662	0.000
Yes	47	28	8		
No	53	72	92		
Household size				30.720	0.000
<8 people	70	38	12		
>=8 people	30	62	88		
Employment of shepherds				42.124	0.000
Yes	19	47	88		
No	81	53	12		
Land ownership				14.384	0.001
Yes	74	94	100		
No	26	6	0		
Favorable pastures				12.160	0.002
Yes	14	36	38		
No	86	64	62		
Equipment				20.399	0.000
Yes	50	64	100		
No	50	36	0		
Possession of truck				17.754	0.000
Yes	17	32	58		
No	83	68	42		
Possession of tractor				49.740	0.000
Yes	2	17	58		
No	98	83	42		
Possession of cart				9.995	0.007
Yes	21	2	8		
No	79	98	92		
Possession of tank				33.902	0.000
Yes	34	55	100		
No	66	45	0		
Possession of pump				39.048	0.000
Yes	12	30	75		
No	88	70	25		
Veterinary care				16.005	0.000
Yes	45	70	83		
No	55	30	17		
Training received				7.850	0.020

(continued)

**Table 5** (continued)

Categorical variables	Small (%)	Medium (%)	Large (%)	Chi-square value	Sig-p
Yes	17	17	42		
No	83	83	58		
BO Membership				27.454	0.000
Yes	11	38	58		
No	89	62	42		

Note: BO: Breeder Organization

**Table 6** Significant factors (continuous variables) explaining the differences observed in the frequency of adaptation practices' adoption between categories of breeders

Variable	Category	Minimum	Maximum	Mean	Standard deviation
Age	Small	22	85	49	13.94
	Medium	24	79	53	12.66
	Large	44	79	62	8.60
Household size	Small	1	14	6	2.63
	Medium	3	16	9	3.00
	Large	5	23	12	4.47
Labor force	Small	0	3	1	0.93
	Medium	0	6	2	1.47
	Large	0	12	4	2.32
Land size	Small	0	52	15	14.81
	Medium	0	196	37	41.05
	Large	8	300	86	82.68
Equipment	Small	0	4	1	1.19
	Medium	0	6	2	1.77
	Large	2	14	5	2.96
Small ruminants herd size	Small	0	180	72	37.31
	Medium	101	500	214	78.57
	Large	355	1400	684	260.00
Bovine cattle herd size	Small	0	10	1	2.20
	Medium	0	13	3	3.70
	Large	0	50	7	10.38

significantly the probability that pastoralists put in place CC adaptation measures. Hassan and Nhemachena (2008) and Ouédraogo et al. (2010) stressed that ownership of heavy machinery or agricultural equipment improves the coping capacities of farmers to deal with the negative effects of climate variability and extremes.

Furthermore, large breeders have specialized over time in the extensive breeding of small ruminants, while small-scale herders have been forced to practice non-farm activities such as casual labor, small trades, and the collection of truffles to obtain additional income necessary for their survival. In fact, almost all large livestock

owners (92%) do not carry out any ancillary activity generating additional income, unlike 53% for small herders. Given that the occupation of the farmer was an indication of the total amount of time available for farming activities (Gbetibouo 2009), the off-farm employment may present a constraint to the adoption of technology because it consumes time which must be devoted to the management of agricultural activities (McNamara et al. 1991). Also, large breeders are the ones who benefit most from the best grazing sites (38 vs. 14%). Berhanu and Beyene (2015) expressed that the traditional pastoralism represents a resilient and unique system of adaptation to hostile and unpredictable climatic variability in dryland ecosystems.

In accordance with the results presented above, several previous studies showed that the significant factors influencing African farmers' adaptation to climate change are socioeconomic household-level variables, and this in many countries such as Ethiopia (Balew et al. 2014; Berhanu and Beyene 2015), South Africa (Taruvunga et al. 2016), Ghana (Ndamani and Watanabe 2016), Tanzania (Below et al. 2012), Nigeria (Obayelu et al. 2014), Kenya (Opiyo et al. 2015), and Uganda (Nabikolo et al. 2012).

---

## Conclusion

In response to perceived climate changes and extremes, livestock breeders in the high plateaus of eastern Morocco have implemented differently many adaptation practices, depending on their respective socioeconomic conditions at household level. Thereby, contrasting socioeconomic characteristics, mainly the size of sheep flock in ownership, allowed large breeders to adopt (put in place) with higher frequency most of adaptive measures compared to small-scale herders who have much more limited possibilities or choices. This social inequality could be exacerbated in the future due to adverse climatic trends (increase in the frequency and intensity of droughts, reduction in rainfall amounts) caused by current and future climate change, in the absence of support measures targeting primarily small breeders who are the most vulnerable group to this climatic phenomenon.

In addition, future studies relating to climate change adaptation in the study area should first investigate the perceptions of livestock producers. Indeed, local perceptions toward climate change influence farmers' decisions on whether or not to adapt (Deressa et al. 2009), are useful for the development of relevant and appropriate adaptation policies and strategies (Opiyo et al. 2015), and are also an important factor influencing the success of the adaptation actions to be implemented (Tsfahunegn et al. 2016).

---

## References

- Balew S, Agwata J, Anyango S (2014) Determinants of adoption choices of climate change adaptation strategies in crop production by small scale farmers in some regions of Central Ethiopia. *J Nat Sci Res* 4(4):78–93

- Bechchari A, El Aich A, Mahyou H, Baghdad B, Bendaou M (2014) Etude de la dégradation des pâturages steppiques dans les communes de Maâtarka et Béni Mathar (Maroc oriental). *J Mater Environ Sci* 5(S2):2572–2583
- Below TB, Mutabazi KD, Kirschke D, Franke C, Sieber S, Siebert R, Tscherning K (2012) Can farmers' adaptation to climate change be explained by socioeconomic household-level variables? *Glob Environ Chang* 22(1):223–235. <https://doi.org/10.1016/j.gloenvcha.2011.11.012>
- Beniston M, Stephenson D, Christensen O et al (2007) Future extreme events in European climate: an exploration of regional climate model projections. *Clim Chang* 81:71–95
- Berhanu W, Beyene F (2015) Climate variability and household adaptation strategies in Southern Ethiopia. *Sustainability* 2015(7):6353–6375. <https://doi.org/10.3390/su7066353>
- Besada H, Sewankambo N (2009) Climate change in Africa: adaptation, mitigation and governance challenges. CIGI Special Report. Centre for International Governance Innovation = Centre pour l'innovation dans la gouvernance internationale, Waterloo, p 49
- Bourbouze A (2000) Pastoralisme au Maghreb: la révolution silencieuse. *Fourrages* 161:3–21
- Bourbouze A, El Aich A (2000) Gestion des parcours et des troupeaux en régions steppiques et réponse à l'aléa climatique. Dans: Guessous F, Rihani N, Ilham A (eds) *Livestock production and climatic uncertainty in the Mediterranean*. EAAP Publication no 94. Wageningen Pers, Wageningen, pp 307–319
- Bruckner M (2012) Climate change vulnerability and the identification of least developed countries (LDCs). The United Nations Development Policy and Analysis Division Department of Economic and Social Affairs. CDP Background Paper no 15, p 29. <https://www.un.org/development/desa/dpad/wp-content/uploads/sites/45/publication/CDP-bp-2012-15.pdf>
- Bzioui M (2012) Gestion des ressources en eau au Maroc et changement climatique. In: Ellinor ZM, Bennis A (eds) *Environnement et changement climatique au Maroc- Diagnostic et Perspectives*. Konrad-Adenauer-Stiftung e.V., Bureau au Maroc, Rabat, pp 63–69
- Debalke NM (2011) Determinants of farmers' preference for adaptation strategies to climate change: evidence from north shoa zone of Amhara region Ethiopia. MPRA Paper no 48753. Ambo University, Addis Ababa University
- Deressa TT, Hassan RM, Ringler C, Alemu T, Yesuf M (2009) Determinants of farmers' choice of adaptation methods to climate change in the Nile Basin of Ethiopia. *Glob Environ Chang* 19:248–255
- Ezouine D, Bouaza N (2019) Climate finance strategy in Morocco. *Am J Clim Chang* 8:482–501. <https://doi.org/10.4236/ajcc.2019.84026>
- Fink A, Christoph M, Born K et al (2010) Climate. In: Speth P, Christoph M, Dieckrüger B (eds) *Impacts of global change on the hydrological cycle in west and Northwest Africa*. Springer, Heidelberg, pp 54–58
- François A, Gauché E, Génin A (2016) L'adaptation des territoires aux changements climatiques dans l'Orient marocain: la vulnérabilité entre action et perceptions. *Vertigo* 16(1):1–25. <https://doi.org/10.4000/vertigo.17177>. <http://journals.openedition.org/vertigo/17177>
- Fussel HM (2007) Adaptation planning for climate change: concepts, assessment approaches, and key lessons. *Sustain Sci* 2(2):265–275
- Garcia D (2008) The climate security divide: bridging human and national security in Africa. *Afr Secur Rev* 17(3):1–17. <https://doi.org/10.1080/10246029.2008.9627480>
- Gbetibouo GA (2009) Understanding farmers' perceptions and adaptations to climate change and variability – the case of the Limpopo Basin, South Africa. IFPRI Discussion Paper 00849. Centre for Environmental Economics and Policy in Africa, University of Pretoria. <http://www.ifpri.org/publication/understanding-farmers-perceptions-and-adaptations-climate-change-and-variability>
- Hassan RM (2010) Implications of climate change for agricultural sector performance in Africa: policy challenges and research agenda. *J Afr Econ* 19:77–105. <https://doi.org/10.1093/jae/ejp026>
- Hassan RM, Nhemachena C (2008) Determinants of African farmers strategies for adapting to climate change: multinomial choice analysis. *Afr J Agric Resour Econ* 2(1):83–104

- Hulme M, Doherty R, Ngaro T, New M, Lister D (2001) African climate change: 1900–2100. *Clim Res* 17(2):145–168
- International Panel on Climate Change (IPCC) (2014) Synthesis report. In: Pachauri RK, Meyer LA (eds) Climate change 2014: contribution of working groups I, II and III to the fifth assessment report of the intergovernmental panel on climate change. Core writing team. IPCC, Geneva. 151pp. [https://www.ipcc.ch/site/assets/uploads/2018/05/SYR\\_AR5\\_FINAL\\_full\\_wcover.pdf](https://www.ipcc.ch/site/assets/uploads/2018/05/SYR_AR5_FINAL_full_wcover.pdf)
- Kuhn A, Heidecke C, Roth A et al (2010) Importance of resource management for livelihood security under climate change in southern Morocco. In: Speth P, Christoph M, Dieckrüger B (eds) Impacts of global change on the hydrological cycle in west and Northwest Africa. Springer, Heidelberg, pp 566–591
- Lazarev G (2008) L'élevage pastoral dans les Hauts Plateaux de l'Oriental du Maroc. Les notes d'analyse du CIHEAM 37:1–32
- Maâtougui A, Acherkouk M, El Fadili M, Elhoumaizi MA (2011) Les pâturages steppiques de l'Oriental marocain. L'essentiel sur l'état de dégradation et les voies d'amélioration. Division de l'information et de la communication, INRA-Edition, Rabat, pp 1–57
- Mabe FN, Sienso G, Donkoh S (2014) Determinants of choice of climate change adaptation strategies in Northern Ghana. *Res Appl Econ* 6(4):75–94
- Mahdi M (2007) Pastoralism and institutional change in the oriental. In: Gertel J, Breuer I (eds) Pastoral Morocco: globalizing scapes of mobility and insecurity. Reichert, Wiesbaden, pp 93–105
- Mahyou H, Tychon B, Balaghi R, Mimouni J, Paul R (2010) Désertification des parcours arides au Maroc. *Tropicultura* 28(2):107–114
- Mahyou H, Tychon B, Balaghi R, Louhaichi M, Mimouni J (2016) A knowledge-based approach for mapping land degradation in the arid rangelands of North Africa. *Land Degrad Dev* 27:1574–1585
- McNamara KT, Wetzstein ME, Douce GK (1991) Factors affecting peanut producer adoption of integrated pest management. *Rev Agric Econ* 13:129–139
- Melhaoui M, Mezrhah A, Mimouni J (2018) Evaluation et cartographie de la sécheresse météorologique dans les hauts plateaux de l'Oriental du Maroc. *Rev Microbiol Ind San Environ* 12(1):71–92
- Mokssit A (2012) Le point sur le changement climatique au Maroc. In: Ellinor ZM, Bennis A (eds) Environnement et changement climatique au Maroc- Diagnostic et Perspectives-. Konrad-Adenauer-Stiftung e.V., Bureau au Maroc, Rabat, pp 35–40
- Moroccan Meteorological Office (2007) Les changements climatiques au Maroc: Observations et projections. DMN (Direction de la Météorologie nationale). Météo Maroc, Casablanca. [https://www.preventionweb.net/files/changements\\_climatiques-214.pdf](https://www.preventionweb.net/files/changements_climatiques-214.pdf)
- Morocco (2011) Projet d'intégration du changement climatique dans la mise en œuvre du plan Maroc vert (Project to integrate climate change into the implementation of the Green Morocco Plan). Ministry of Agriculture and Maritime Fisheries and the Agency for Agricultural Development. <http://www.ada.gov.ma/uplds/pars/ECIESPICCPMV.pdf>
- Morocco (2016) 3<sup>ème</sup> Communication Nationale du Maroc à la Convention Cadre des Nations Unies sur les changements climatiques (The third national communication of Morocco to the United Nations Framework Convention on Climate Change). Ministry Delegate to the Minister of Energy, Mines, Water and Environment in charge of the Environment. <https://unfccc.int/resource/docs/natc/maroc3.pdf>
- Nabikolo D, Bashaasha B, Mangheni MN, Majaliwa JGM (2012) Determinants of climate change adaptation among male and female headed farm households in eastern Uganda. *Afr Crop Sci J* 20(s2):203–212
- National Intelligence Council (NIC) (2009) North Africa: the impact of CC to 2030 (Selected Countries). A Commissioned Research Report NIC 2009-007D. [https://www.dni.gov/files/documents/climate2030\\_north\\_africa.pdf](https://www.dni.gov/files/documents/climate2030_north_africa.pdf)
- Ndamani F, Watanabe T (2016) Determinants of farmers' adaptation to climate change: a micro level analysis in Ghana. *Sci Agric* 73(3):201–208

- Obayelu OA, Adepoju AO, Idowu T (2014) Factors influencing farmers' choices of adaptation to climate change in Ekiti State, Nigeria. *J Agric Environ Int Dev* 108(1):3–16. <https://doi.org/10.12895/jaeid.20141.140>
- Opiyo F, Wasonga OV, Nyangito MM, Mureithi SM, Obando J, Munang R (2015) Determinants of perceptions of climate change and adaptation among Turkana pastoralists in northwestern Kenya. *Clim Dev*. <https://doi.org/10.1080/17565529.2015.1034231>
- Ostertagova E, Ostertag O, Kováč J (2014) Methodology and application of the Kruskal-Wallis test. *Appl Mech Mater* 611:115–120
- Ouédraogo M, Dembélé Y, Somé L (2010) Perceptions et stratégies d'adaptation aux changements des précipitations: cas des paysans du Burkina Faso. *Sécheresse* 21(2):87–96. <https://doi.org/10.1684/sec.2010.0244>
- Paeth H, Born K, Girmes R et al (2009) Regional climate change in Tropical and Northern Africa due to greenhouse forcing and land use changes. *J Clim* 22:114–132
- Piya L, Maharjan KL, Joshi NP (2013) Determinants of adaptation practices to climate change by Chepang households in the rural Mid-Hills of Nepal. *Reg Environ Chang* 13:437–447. <https://doi.org/10.1007/s10113-012-0359-5>
- Rachik H (2007) Nomads: but how? In: Gertel J, Breuer I (eds) *Pastoral Morocco – globalizing scapes of mobility and insecurity*. Reichert, Wiesbaden, pp 211–252
- Schilling J, Freier KP, Hertig E, Scheffran J (2012) Climate change, vulnerability and adaptation in North Africa with focus on Morocco. *Agric Ecosyst Environ* 156:12–26
- Tarvinga A, Visser M, Zhou L (2016) Determinants of rural farmers' adoption of climate change adaptation strategies: evidence from the Amathole District Municipality, Eastern Cape Province, South Africa. *Int J Environ Sci Dev* 7(9):687–692. <https://doi.org/10.18178/ijesd.2016.7.9.863>
- Tesfahunegn GB, Mekonen K, Tekle A (2016) Farmers' perception on causes, indicators and determinants of climate change in northern Ethiopia: implication for developing adaptation strategies. *Appl Geogr* 73:1–12
- Tiwari KR, Rayamajhi S, Pokharel RK, Balla MK (2014) Determinants of the climate change adaptation in rural farming in Nepal Himalaya. *Int J Multidiscip Curr Res* 2:234–240
- Yila JO, Resurreccion BP (2013) Determinants of smallholder farmers' adaptation strategies to climate change in the semi-arid Nguru Local Government Area, Northeastern Nigeria. *Manag Environ Q Int J* 24(3):341–364
- Yohe G, Malone E, Brenkert A et al (2006) Global distributions of vulnerability to climate change. *Integr Assess* 6:35–44

**Open Access** This chapter is licensed under the terms of the Creative Commons Attribution 4.0 International License (<http://creativecommons.org/licenses/by/4.0/>), which permits use, sharing, adaptation, distribution and reproduction in any medium or format, as long as you give appropriate credit to the original author(s) and the source, provide a link to the Creative Commons license and indicate if changes were made.

The images or other third party material in this chapter are included in the chapter's Creative Commons license, unless indicated otherwise in a credit line to the material. If material is not included in the chapter's Creative Commons license and your intended use is not permitted by statutory regulation or exceeds the permitted use, you will need to obtain permission directly from the copyright holder.





# Triple Helix as a Strategic Tool to Fast-Track Climate Change Adaptation in Rural Kenya: Case Study of Marsabit County

# 92

Izael da Silva, Daniele Bricca, Andrea Micangeli, Davide Fioriti, and Paolo Cherubini

## Contents

Introduction .....	1874
The Triple Helix .....	1876
The Role of the University .....	1876
The Relationships between University, Government, and Industry .....	1877
Triple Helix in Africa .....	1877
Triple Helix for Sustainability and Climate Change .....	1879
Energy Access and Climate Change in Kenya .....	1880
Country Overview .....	1880
Climate Change .....	1881
Rural Electrification in Kenya .....	1881
Case Study – Marsabit County, Kenya .....	1883
Overview .....	1883
Energy Access in Marsabit .....	1884

This chapter was previously published non-open access with exclusive rights reserved by the Publisher. It has been changed retrospectively to open access under a CC BY 4.0 license and the copyright holder is “The Author(s)”. For further details, please see the license information at the end of the chapter.

I. da Silva (✉)  
Strathmore University, Nairobi, Kenya  
e-mail: [idasilva@strathmore.edu](mailto:idasilva@strathmore.edu)

D. Bricca  
Sapienza University of Rome, Rome, Italy

A. Micangeli  
DIMA, Sapienza University of Rome, Rome, Italy  
e-mail: [andrea.micangeli@uniroma1.it](mailto:andrea.micangeli@uniroma1.it)

D. Fioriti · P. Cherubini  
DESTEC, University of Pisa, Pisa, Italy  
e-mail: [davide.fioriti@ing.unipi.it](mailto:davide.fioriti@ing.unipi.it); [paolo.cherubini@ing.unipi.it](mailto:paolo.cherubini@ing.unipi.it)

Marsabit Town .....	1886
Illaut .....	1887
Laisamis .....	1889
Discussion .....	1889
Conclusions .....	1891
References .....	1892

## Abstract

The lack of affordable, clean, and reliable energy in Africa's rural areas forces people to resort to poor quality energy source, which is detrimental to the people's health and prevents the economic development of communities. Moreover, access to safe water and food security are concerns closely linked to health issues and children malnourishment. Recent climate change due to global warming has worsened the already critical situation.

Electricity is well known to be an enabler of development as it allows the use of modern devices thus enabling the development of not only income-generating activities but also water pumping and food processing and conservation that can promote socioeconomic growth. However, all of this is difficult to achieve due to the lack of investors, local skills, awareness by the community, and often also government regulations.

All the above mentioned barriers to the uptake of electricity in rural Kenya could be solved by the coordinated effort of government, private sector, and academia, also referred to as Triple Helix, in which each entity may partially take the other's role. This chapter discretizes the above and shows how a specific county (Marsabit) has benefited from this triple intervention. Existing government policies and actions and programs led by nongovernmental organizations (NGOs) and international agencies are reviewed, highlighting the current interconnection and gaps in promoting integrated actions toward climate change adaptation and energy access.

## Keywords

Triple helix · Rural electrification · Wealth creation · Climate change adaptation · Suitable policies and regulations

## Introduction

Energy poverty is a serious concern in developing countries which often are the ones to bear most of the negative consequences of climate change. Currently, about 2.6 billion people have no access to clean cooking and about 850 million do not have access to electricity (International Energy Agency (IEA) 2019a). Some of these consequences are deficient healthcare systems, lack of access to education, and lower economic growth leading to political instability and migratory flows. Despite of international agencies' support and local government fund allocation, still 500 million people are expected to have no access to electricity by 2030 (International



Energy Agency (IEA) 2019b). All of the above are worsened by climate upheaval such as droughts, floods, and rain shortage (Trenberth et al. 2014).

Energy, food, and water are scarce and of low quality for people living in rural areas of developing countries. Food insecurity affects about 10–11% of people worldwide with peaks of 30% in east Africa (FAO 2019), or even beyond as confirmed by the surveys performed by Fraval et al. (2019). Food is often cooked without proper cooking facilities, often with firewood or charcoal, and exhaust gases are released inside the rooms without a proper ventilation system (Goldemberg et al. 2018). This affects the healthy conditions of inhabitants and especially children (Smith et al. 2014). Moreover, according to UNICEF, only about 30% of people in Sub-Saharan Africa had access to safely managed drinking water in 2017, whereas 30% of them had limited or inadequate access (UNICEF and WHO 2019). Often, water is far from settlements and unemployed people, usually children or women, have to walk several kilometers a day for procuring water for the family (UNICEF and WHO 2019). Furthermore, lack of water and scarce hygiene can facilitate the widespread of diseases (UNICEF and WHO 2019). Energy poverty, hunger, and no access to clean water are extremely correlated not only among themselves but also with low hygiene and low development rates (FAO 2019).

Electricity is widely recognized as a major determinant for social and economic development (Gambino et al. 2019), as it can allow the use of modern devices to be used for commercial or small industrial activities. The attention that African governments have paid on fostering access to electricity is justified by the correlation between electricity and income, as well as with the social development index (Zhang et al. 2011; FAO 2019). In fact, access to modern energy can have significant effects on poverty and access to water and reduce hunger, which are all significant priorities stated by United Nations (International Energy Agency (IEA) 2019a). Renewable energy-based electricity can provide reduction in CO<sub>2</sub> emissions by reducing the recourse to coal-based electricity in communities already reached by the national grid, by hybridizing with renewable sources existing mini grids mostly powered by diesel gensets (Micangeli et al. 2017), and by displacing the use of traditional fuels for lighting (Micangeli et al. 2017; Ambition to Action 2019). As an example, small-scale irrigation can contribute to income diversification and livelihood resilience (Murphy and Corbyn 2013).

Governments in developing countries often cannot enforce a fast development of rural electrification alone, due to lack in financial resources, know-how, or human capacity (Franz et al. 2014). On this regard, the involvement of the private sector as well as know-how holders, such as universities and international entities, is considered crucial (Franz et al. 2014), also to prevent the consequences that climate change may cause on already critical situations. Recent modern business models exploit the benefits of the integrated approach of the so-called energy-water-food nexus, by which the developer brings in electricity service, which in turn avails services like water and food through irrigation (Res4Africa 2019).

Universities produce knowledge and promote long-term growth through innovation and technology transfer to private and public sector. On the other hand, governments develop guidelines and policies in order to guide the industry toward

the long-term social benefits for society. By considering the above, it is clear that significant synergies among the three entities can be explored and this cooperation is called “Triple Helix” (Leydesdorff and Etzkowitz 1995; Carayannis and Campbell 2010), which is proposed in this chapter as a tool to foster climate change adaptation in Kenya, with the special attention to the Marsabit County, an area heavily hit by climate change and subject to draughts and floods.

In section “[The Triple Helix](#),” the Triple Helix concept is detailed, including applications for rural electrification, Africa, and sustainability concerns. In sections “[Energy Access and Climate Change in Kenya](#)” and “[Case Study – Marsabit County, Kenya](#),” the case study is introduced and in section “[Discussion](#)” the major discussions are proposed. Finally, the conclusions are made.

---

## The Triple Helix

The concept of Triple Helix (TH) has been proposed in the 1990s (Leydesdorff and Etzkowitz 1995) as a new framework to conceptualize relationships between university, government, and industry, to address the need of organizational innovation in a knowledge-based society. Innovation, defined as “reconfiguration of elements into a more productive combination” (Etzkowitz 2008), requires, in this view, a central role of the university, since innovation is not merely attributable to new product development by the industrial sector (Etzkowitz 2008).

## The Role of the University

It has been acknowledged, in a seminal work made by Gibbons et al. (Gibbons et al. 1994), that the very production of knowledge has transitioned from a “traditional” framework, labeled Mode 1, driven and administered by classic academia in a disciplinary context, to a new mode, labeled Mode 2. In this new framework, knowledge is produced in the context of application, by a variety of actors coming from different disciplines, in an interactive relationship with society as a whole, both in defining the problems and research goals, and in diffusion of results. In recognition of the different way of knowledge production, and the role that it acquired in innovation, the university reshaped its mandate. The first modern universities were created in the twelfth century with the purpose of preservation and dissemination of knowledge (teaching mission). In the nineteenth century a second mission – research – was added, and more recently a third mission, that of contribution to economic development (Etzkowitz 2003). This mission requires an entrepreneurial model to be adopted by academia, that is not limited to preservation and transmission of knowledge but is involved proactively in technology transfer and incubation activities (Etzkowitz 2003). Furthermore, Carayannis et al. proposed the concept of “Mode 3” in which knowledge is produced by pluralism and diversity of knowledge, in a Triple, Quadruple, or Quintuple Helix framework, also including a combination of modes 1 and 2 (Carayannis and Campbell 2010).

## The Relationships between University, Government, and Industry

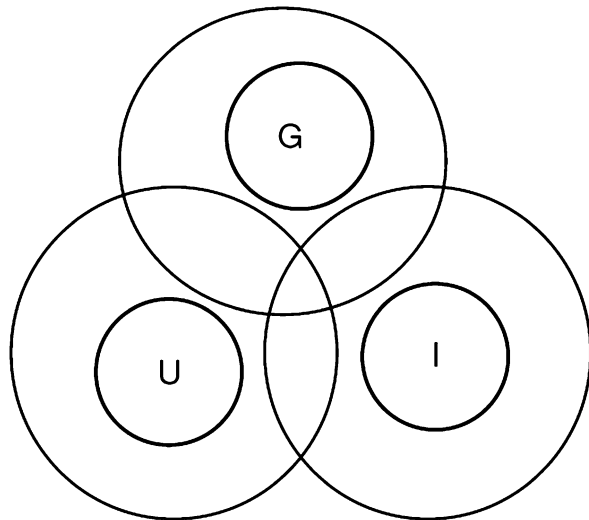
The relationships among these three entities can be visualized as lying among two extremes: a centralized model where the government guides science policy and industrial development (“statist model”) or a situation of very limited interaction, where each entity attains its core mandate separately from the others (“laissez-faire model”) (Etzkowitz 2008). To visualize the interactions typical of the TH, Fig. 1 shows the “field interaction model” proposed by Eskowitz (Etzkowitz 2008) that schematizes government, industry, and university as three spheres with an inner core, representing their specific functions, and outer cores that overlap as each entity “takes the role of the other on a synergetic manner.”

It is argued that the TH concept could act as a flywheel in pursuing a path of compliance with the objectives set out by the Sustainable Development Goals (SDGs) for rural areas of developing countries. However, TH dynamics has usually referred to a context of discontinuous innovation in advanced technological sectors such as ICT (Information and Communication Technology), semiconductors, or biotechnology. The most iconic example of regional development led by TH dynamics is the one of Silicon Valley, an international hub for high-tech companies animated by Stanford University’s knowledge development (Etzkowitz 2012). In the following section, we will look at how the TH framework has been applied and discussed in the African context and how it has been integrated or reformulated to embed the sustainability issues underpinned by the SDGs.

### Triple Helix in Africa

Rarely TH applications have been found in Africa. As noted by Outamha and Belhacen (Outamha and Belhacen 2020), the core mission of university in the

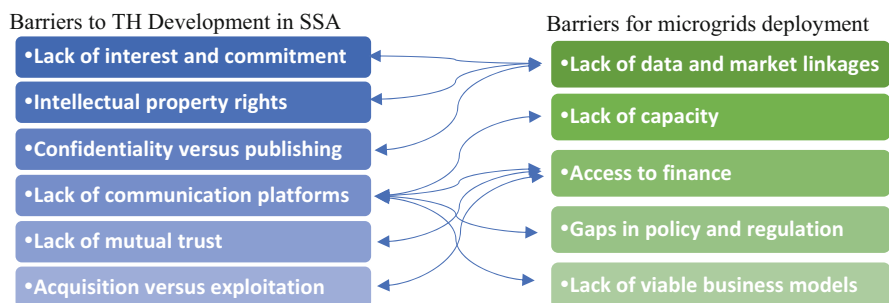
**Fig. 1** Triple Helix field interaction model (Etzkowitz 2008)



continent is still the provision of human capital to industry and government, hence it is not on par with the global standards of knowledge-based societies. The historical reasons for this have been identified by some authors in the focus on mass primary and universal education over higher education in aid programs, at the expense of higher education (Dzisah 2011).

In Outamha and Belhcen (2020), a list of challenges that interconnections between university and industry are facing in Africa is given and shown in Fig. 2, together with the challenges for the implementation of mini-grids for rural electrification (African Development Bank Group et al. 2016). The different points are shown below:

- The lack of data regarding mini-grid projects reflects the lack of interest and commitment from industry to share information and collaborate in knowledge creation and diffusion, aggravated by confidentiality and property right concerns.
- Lack of capacity for mini-grid development reflects the lack of interest and lack of communication platforms to socially disseminate results of application-oriented curricula (Perez-Arriaga et al. 2018).
- Lack of access to finance reflects the lack of entrepreneurial prowess on the university side, resulting in lack of interest and aggravated by lack of mutual trust and lack of communication platforms bringing together the other two sectors.
- Gaps in policy and regulation reflect that academic curriculums in universities, prioritizing human capital formation, tend to not address the training of leaders that can give an answer to structural problems undermining the development of countries.
- Lack of viable business models is also a consequence of a lack of coordinated effort from governments planning for electrification plans, state-owned utilities, private actors, and academics in analyzing and reviewing current on-field experiences and contributing to develop improved models, overcoming contradictions



**Fig. 2** Proposed linkages between barriers to university-industry linkages in SSA (Outamha and Belhcen 2020), on the left, and the barriers to development of Green Mini-Grids in SSA (African Development Bank Group et al. 2016), on the right

between knowledge acquisition by universities and commercial exploitation by private sector players.

The adoption of a TH framework has been proposed for the energy sector in SSA, specifically for the development of photovoltaic installations in Uganda (Da Silva and Wassler 2011). There are examples of spin-off companies operating in the Solar Home System sector in SSA, such as BBOX (from Imperial College of London) and Azuri Technologies (from Cambridge University) (Bagley et al. 2018). By looking at these two companies, it is worth highlighting the issue of the “localization” of TH dynamics for the specific case, as they are firms born from non-African universities but working on African ground with local government and international entities.

In tackling the issue of electricity access conjointly with the food and water security and climate change adaptation issues, it has to be kept in mind that is a sector of intervention with serious concerns of bankability of investments (Kottász and Draeck 2017), especially for the realization of mini-grids, and in which international organizations and NGOs play a leading role. Therefore, there is, on the one hand, a multiplicity of stakeholders (i.e., NGOs) that are not present in the classic TH model, and on the other hand, a geographical globalization by which interventions directed at rural communities of developing countries involve not only local governments, universities, and industries but also international counterparts, mobilized by the concerns and goals of international agencies and non-profit organizations. As an example, in Moore et al. (2015) a program for ICT (Information and Communication Technology) education for Rwandan teachers is discussed as a possible example of TH development, albeit “loosely” not only because of the leading role of the local government in proposing the program, supported by local academia and privates, but also for the role of UNESCO and foreign cooperation agencies, factors that “are missing from the model.”

## Triple Helix for Sustainability and Climate Change

The original TH model did not entail sustainability issues linked to innovations. Etzkowitz and Zhou (Etzkowitz and Zhou 2006) proposed to consider a second TH system, one of university, government, and public to act as a counterbalance to technological innovations introduced by the university-government-industry triad, by representing the “dynamic of controversies over technological innovation.” This picture of twin helices was chosen to maintain the triadic nature of each one, whereas other authors have proposed to the inclusion of a fourth helix – representing civil society, in form of NGOs or other associations of citizens – and a fifth helix, accounting for the natural environment of society (Carayannis et al. 2019). A quadruple helix approach has been proposed specifically for Africa (Kimatu 2015), as it could provide the needed “sustainable innovation ecosystem” to accelerate economic development. Similarly, a quadruple helix approach is advocated in (Amaro et al. 2014) for Guatemala, a country vulnerable to extreme climate events

that shows a lack of awareness for climate change effects and related action systems, and that could therefore benefit from a TH intervention integrated with civil society actors.

Finally, other authors criticized the underlying paradigm of the university role in a TH model, namely the concept of third mission pursued by an entrepreneurial university, highlighting how the adoption of market logics promoted profit over the technology transfer; the new mission for academic institutions should be that of “creating societal transformations in pursuit of realizing sustainable development” (Trencher et al. 2014). In this perspective, with the goal of materializing sustainable development in a specific context, a function of “co-creation for sustainability” is proposed for the university, beyond the conventional research and development and product improvement through innovation.

---

## Energy Access and Climate Change in Kenya

### Country Overview

Kenya is an equatorial country of about 580,000 km<sup>2</sup> located in East Africa with significant different climate conditions varying from desertic to humid areas. With a gross domestic product (GDP) of 87.9 billion USD in 2018 with an average growth rate of about 9% in the past 10 years and a population of about 51.4 million people in 2018, Kenya is experiencing a strong economic growth (World Bank 2020). In the last 20 years, the GDP per capita has grown steadily and even poor people have benefited as the poverty ratio decreased by 36% over the period.

However, the Sustainable Development is not achieved in Kenya; still many people live below the poverty line, rarely water is safely managed with even no basic service in 40% of cases (UNICEF and WHO 2019), hunger significantly affects 10–40% of the children 5 year old or younger (FAO 2019), and sanitation and hygiene is even worse, also affecting maternity-related concerns (UNICEF and WHO 2019). Energy access is still limited: about 25% of people do not have access to electricity and an even larger proportion (75%) have no clean cooking facilities (World Bank 2020). Altogether, inequalities are significant, as also proven by the high 40% Gini index (2015) (World Bank 2020). Nevertheless, these problems have been decreasing.

In order to promote growth and tackle these challenges, the government has developed and implemented the Kenya Vision 2030 program in 2007 (Ministry of Planning and National Development 2007) with significant pillars based on macro-economic stability, measures for the poor, capacity building, research, infrastructures, and energy. A new constitution was promulgated in 2010 and the corresponding legislation and administrative procedures have been set up the following year. The reform laid the bases for the decentralization of power into county-level governments able to develop local policies and tax reform accounting for the specific problems of the territory (Ministry of Planning and National Development 2007; Ngigi and Busolo 2019). The Devolution, which was ushered in 2013,

has benefits in terms of a more equitable distribution of resources, economic and social development, political participation of citizens, enhanced transparency and accountability of governments, and even unity (Ngigi and Busolo 2019).

## Climate Change

Kenya is vulnerable to climatic events, mainly droughts and floods. According to the National Adaptation Plan (NAP) launched in 2016 (Government of Kenya 2016), droughts have been recurring in the past 40 years, affecting millions of people by disrupting pastoral and agricultural activities, causing famine and population displacement. Floods, which are recurring phenomena as well, cause loss of human lives and damages to infrastructure, such as roads or power lines, hence potentially leading to problems to the transportation sector and the supplying of basic services to the population. Moreover, the areas subject to floods can experience the spreading of waterborne or sanitation-related diseases in the subsequent period (Government of Kenya 2016), as humid conditions ease the widespread of diseases, excrements and sewage are difficult to contain, especially in case of open defecation (UNICEF and WHO 2019), and the damaged infrastructure delay possible aid (Bündnis Entwicklung Hilft (Alliance Development Works) and United Nations University – Institute for Environment and Human Security (UNU-EHS) 2016). Given the damage and risks due to these extreme events, local and international entities have developed policies and dedicated programs for droughts and disaster risk management in Kenya, as detailed in Global Water Partnership Easter Africa (GWPEA) (2015).

## Rural Electrification in Kenya

In Kenya Vision 2030, the “long-term development blueprint for the country” launched in 2007 (Ministry of Planning and National Development 2007), energy is considered a foundational infrastructure to enable the goals set out by the government on the economic, social, and political governance pillars. To address the specific issue of electricity access in rural areas, the Rural Electrification Authority (REA) was created in 2007, and then with the 2019 Energy Act adopted in March 2019 (Republic of Kenya 2019), REA has been changed to Rural Electrification and Renewable Energy Corporation (REREC). REREC has the mandate to develop and implement the rural electrification program of Kenya and to manage a dedicated Rural Electrification Programme Fund, also established by the Energy Act.

This choice reflects the change of pace in the country’s objectives: the target for 100% electricity access in rural areas originally set out for 2030 (Rural Electrification Authority (REA) 2008) has been moved to 2022 in 2013 (Kenya Ministry of Energy 2018), as electricity is considered a key backbone for the achievement of the “big four agenda” (Republic of Kenya – The National Treasury and Planning 2018) pivoted on enhancing food security, universal healthcare, affordable housing, and

increasing the GDP share of manufacturing and agri-processing activities. Kenya has been the fastest African country in closing the access gap, with an annualized increase in access of 6.4 percent points between 2010 and 2017, with a remaining deficit of 18 million people without access, corresponding to a 63.8% access rate in 2017 (IEA et al. 2019).

According to the national electrification strategy, universal access will be achieved mostly via grid intensification and densification (2.77 million connections), standalone solar systems (1.96 million connections), grid expansion (269,000 connections), and mini-grids (35,000 connections) (Kenya Ministry of Energy 2018).

Research showed that the mere presence of grid infrastructure in Kenya does not translate to high rate of consumer takeoff, even for “under grid” households that are within 200 m of a low voltage power line (Lee et al. 2014). To address this issue, the Last Mile Connectivity Program has been launched, to tackle the key issue of affordability of the connection fee, lowered from 398 to 171 USD, including the opportunity of paying in monthly installments.

On the other hand, the construction of the mini-grids, foreseen by the national electrification strategy, will fall under the Kenya Off-Grid Solar Access Project (KOSAP), started by the Ministry of Energy in July 2017 and financed by the World Bank (Ministry of Energy 2018). The project benefits 14 underserved counties in the northern and eastern regions of Kenya, including the Marsabit County, and envisages providing standalone systems, for dispersed users and public facilities, clean cookstoves, solar water pumps for community facilities, and mini-grids in selected target communities. As per government data, the number grew to 151 after the field surveys (Ministry of Energy 2019a). It is worthy noticing that KOSAP integrates environmental concerns, citizen engagement, a capacity building component – also directed at county governments – and incentives for private sector involvement. The mini-grids to be developed under this framework, in fact, will be developed under a public-private partnership (PPP) lasting 7–10 years by which generation facilities will be co-funded by public and private actors, and distribution networks will be built with public funds only (KP and REA 2017). Until the PPP lasts, the O&M of generation and distribution assets will be performed by a single private service provider (PSP), while the final users will be KP customers subject to the national tariff (KP and REA 2017); thereafter, all the assets, hence both the generation and distribution ones, will be owned by the Government of Kenya.

According to the National Electrification Strategy, the funding allocated on improving the national grid are about 2.3 billion USD over five years, accounting for about 82% of the total. The interventions are expected to focus on the installation of new transformers (grid densification), on the extension of existing MV lines up to 2 km to reach new customers (grid intensification) and also on the extension of the distribution system with longer lines expansion within 15 km the existing backbone (grid extension). These measures focus on areas relatively close to the existing network; yet, rural areas are not overlooked. In fact, about 18% of the funding will fund mini-grids and solar home systems (SHS) with the goal of reaching the people that cannot be reached by the other measures. SHS will receive more than ten times the funding with respect to mini-grids (Kenya Ministry of Energy 2018); yet, the



potential for mini-grid development in Kenya may have been underestimated in the national planning strategy, as detailed in a series of technical reports and scientific papers (Ambition to Action 2019).

---

## Case Study – Marsabit County, Kenya

In this section we describe the major activities in the view of the TH concept that have been developed in Marsabit, Kenya. The information reported here are based on the available literature and the knowledge of the experienced authors, also based on field work. Three case studies have been chosen for this book chapter due to the different types of conditions and information they represent.

### Overview

Marsabit is one of the 47 counties created with the 2010 Constitution of Kenya, located in the northern part of the country, bordering Ethiopia. According to the most recent census, held in 2019, Marsabit has 459,785 inhabitants occupying a total of 67,000 square kilometers, making it the least densely inhabited county in Kenya, with an average population density of 6 persons/km<sup>2</sup> (Kenya National Bureau of Statistics 2019). The agroclimatic zones range between very-arid (zone VII) to semi-humid/semi-arid (zone IV). The prevalent land cover is barren land (65.4% of the total area), which is only fit for pastoralist activities (Wiesmann et al. 2016). Rural population engaged in agri-pastoral activities is largely nomadic, moving around the countryside according to the seasons in search of food, water, and grazing land.

The poverty rate in Marsabit registered with the 2009 census was 75.8%, the fourth overall highest among Kenya, with a poverty severity of 8.8% with respect to a 4.89% national average (Wiesmann et al. 2016). The living conditions are very different among the various sub-counties and among towns and rural areas. All the settlements around the main northern road, which goes from Merile to Moyale and connects Kenya to Ethiopia, have the advantage of increased access to goods coming from all the county and benefit from the presence of numerous investors, which started setting foot in the region since devolution and significantly increased their presence during the last few years. In a comparative analysis done among Isiolo, Marsabit, and Meru counties, Marsabit exhibited the lowest resilience capacity index (FAO 2017). The main reason was a poor adaptive capacity, linked to low education levels and low income diversification, given the predominance of pastoral activities (FAO 2017).

Although the region is one of the lowest developed in Kenya, food insecurity affects a limited share of the population (10–15%) given the large consumption of milk, but there is serious/critical malnourishment among above 15% of children and it is also stated that the whole population is even at significant risk of food insecurity in case of drought emergency (UNICEF 2017). Moreover, despite improvement in the years, water access is still a problem. Socioeconomic analyses revealed that only 26.4% of population above 3 year old is currently enrolled in school, whereas 63.4%

of the population has never attended one (Kenya National Bureau of Statistics 2019). The typical economic activities are farming and livestock production, with a minority practicing fishing (1295 households out of 77,495), yet with no commercial-oriented business as the majority of households conduct these activities for subsistence (Kenya National Bureau of Statistics 2019). At the time of writing, the release of the 2019 census is still incomplete, so for other relevant data figures provided will refer directly or indirectly through secondary literature, to the 2009 census.

Given the climate and soil conditions, about 80% of the population is involved in pastoral production, a sector extremely vulnerable to not only recurrent droughts that have caused losses for over 60% of livestock in recent years but also floods that have also caused sweeping the cattle and killing them (The Ministry of Agriculture Livestock and Fisheries (MoALF) 2017). There are no perennial rivers but only four seasonal drainage systems (Marsabit County Government 2018); therefore, only 38.2% of the households have access to safe water (Wiesmann et al. 2016). The county is dependent on short rains for 80% of food security and on long rains for 20% (Kenya Food Security Steering Group (KFSSG) and Marsabit County Steering Group 2017). Moreover, the irrigated areas for the major crops (maize, tomatoes, and kales) declined also due to high maintenance costs for irrigation and low recharge of surface water sources (Kenya Food Security Steering Group (KFSSG) and Marsabit County Steering Group 2017).

Aiming to adapt to these challenges, some locals have attempted to develop activities such as water harvesting, value addition to local products, conservation of soil and water, tree planting, business diversification, selection of more resistant livestock types, yet in an insufficient and uncoordinated way, and the lack of access to electricity and good infrastructure are clearly additional barriers (The Ministry of Agriculture Livestock and Fisheries (MoALF) 2017). Deforestation in the lowlands in combination with droughts contributes to reduced water flows, health issues, and undermining of food security and strongly affects not only the living condition of the population but the farming businesses, agriculture targeting programs, and pastoralist pathways and lowers drastically the level of security due to land use conflicts (The Ministry of Agriculture Livestock and Fisheries (MoALF) 2017). Armed fights, which can also have a tribal nature across counties, result in human and livestock deaths, destruction of crops and homesteads, fear, and poverty.

## **Energy Access in Marsabit**

Energy access in Marsabit County is restricted to urban centers, always supplied by off-grid solutions with the exception of the towns of Sololo and Moyale, which are interconnected to the Ethiopian national grid, thanks to their proximity to the border (Republic of Kenya and County Government of Marsabit 2018). A list of public mini-grids active in the county is provided in Table 1, the only known active private mini-grid in Table 2, and the list of 13 sites in which mini-grids will be built under KOSAP in Table 3. Also, a list of 26 medical, school, and public facilities to be

**Table 1** Operational public mini-grids in Marsabit (Nygaard et al. 2018; Ambition to Action 2019)

Off-grid station	Diesel (kW)	Solar (kWp)	Wind (kWp)	Battery capacity (Ah)	Connections	Commissioning date
Marsabit	2900	0	500	0	8200 (June 2016)	1977
North Horr	184	0		0	160 (June 2016)	2016
Laisamis	264	80		27,816	160 (June 2016)	2016
Illaut	50	60	0	76,800	200	2019
Ambalo	50	60	0	76,800	200	2019
Balesa	50	60	0	76,800	n/a	2019
Total	3498	260	500	258,216	8920	

**Table 2** Operational private mini-grids in Marsabit (Blodgett et al. 2017; Nygaard et al. 2018)

Mini-grid	Developer	Solar (Wp)	Commissioning date	Customers
Merile	Vulcan Inc.	1.5	2014	27

**Table 3** Mini-grids to be built in Marsabit County under KOSAP (Ministry of Energy 2019a)

Mini-Grid	Potential customers
Bubisa	329
Kargi	379
South Horr	496
Loiyangalani	1051
El Gadhe	108
Gatab	299

benefited by KOSAP intervention in the county has been published (Ministry of Energy 2019b). Finally, there are also private projects, however, often supported by international cooperation (KfW/GIZ/EnDEV) such as for the mini-grids to be developed in Dukana, Illeret, Ngurunit, Dabel, and Diridima (Energies Development 2018; Nygaard et al. 2018).

Moreover, although being a low developed area, there have been developed some large-scale projects in recent years. First of all, given the large wind power potential available in areas of the region, a large scale 310 MW wind farm, representing about 15% of the installed capacity, has been developed close to lake Turkana and connected to the national grid in September 2018 (LTWP 2018). Furthermore, given the proximity with the Ethiopian border, a 263-km HVDC transmission line has been developed as part of the Eastern Electricity Highway Project interconnecting Kenya and Ethiopia (KETRACO 2018). Despite the location of these large electrification projects, the County has not benefited from them in terms of increased access to electricity because low energy demand does not justify the installation of substations. However, the projects have led to enhance and tarmac the 195-km road infrastructures connecting South Horr with Laisamis (code D371) and with Loiyangalani (code C77), with the objective of easing the transport of materials

and equipment for the construction of the wind farm (Lake Turkana Wind Power Limited 2011). Moreover, under the LAPSET project the tarmacking of the Isiolo-Moyale highway has been completed, with significant economic benefits and enhanced accessibility for the region (Republic of Kenya and County Government of Marsabit 2018). The next step of the project, to be developed in future years, is the development to complete the corridor with a railway line (Republic of Kenya and County Government of Marsabit 2018).

The increased level of economic activities along the Isiolo-Moyale road is also visible as shops and residential houses are quickly sprouting by the highway. Local people are moving slowly from pastoralism to different types of business in this area or are using part of their herd to try and invest in diverse activities.

The Marsabit County set out the development of renewable energy sources as a recommendation for climate change mitigation and adaptation, aspiring to exploit the solar and wind potential of the region (Republic of Kenya and County Government of Marsabit 2015). However, the same document stated the lack of human capacity and investment opportunities as barriers for development of energy projects, as well as high fuel costs in construction machineries that hinder investments (Republic of Kenya and County Government of Marsabit 2015).

During the 2013–2017 period, the county provided over 2000 energy saving charcoal burners (*jikos*) to households, 417 solar street poles, and distributed solar panels to schools with the goal of improving the household reliance on biomass and kerosene that can significantly affect the health of people (Republic of Kenya and County Government of Marsabit 2018). While the goal for solar street poles set out in the previous integrated development plan has been exceeded, the other targets for the distribution of 500,000 *jikos*, start-up of a solar equipment enterprise, installation of solar pump driven boreholes, and construction of a power station per constituency have not been fulfilled yet (Republic of Kenya and County Government of Marsabit 2015, 2018).

In the current development plan, not only the previous targets have been restated and expanded but also specific funds have been dedicated for Centre for Renewable Energy Studies and Research of Marsabit County (Republic of Kenya and County Government of Marsabit 2018) to help overcome the knowledge gaps limiting the supply of energy to the population.

## **Marsabit Town**

Marsabit Town is the main town in the county and is situated on an isolated extinct volcano, Mount Marsabit, where the environmental conditions are completely different from the rest of the region.

Devolution, started in 2013, had a broad impact on the development of Marsabit Town that became the county government headquarter, thus, not only the center of all international organizations operating in the county but even of all the various ministries of regional government. As a result, the town is attracting a growing number of investors with several companies setting up business and effectively

opening up the northern frontier region market. Marsabit market, especially during Saturdays, became the first market in the County. Cereals and legumes are imported directly from Ethiopia, while vegetables come from the area around Meru. Between 2013 and the 2019 more than 40 schools were built and one level 5 hospital, in addition to the one run by CARITAS. In the town there is the presence of numerous clinics and dispensaries, mostly in the scattered sublocations. Marsabit Town currently has more than 50 primary schools, 15 secondary ones, and 2 technical institutes, accounting both public and private institutions. All the secondary schools and most of the primaries are electrified, reflecting as per the first phase of REA's strategic plan for 2008–2012 (Rural Electrification Authority (REA) 2008).

The town is served by a mini-grid installed by REREC and operated by Kenya Power with an installed capacity of 3.1 MW (2.6 MW from three diesel generators and 500 kW from wind turbines). The system was commissioned in 1977, with the generation capacity growing steadily and number of connections steeply rising, especially after devolution came into place. As most of the public infrastructure has then been built and reaching around 8200 customers as per June 2016. The medium voltage lines used to connect the public facilities have then been used to give access to households located within 600 meters of an existing transformer, with the uptake from final users facilitated by the Last Mile Connectivity Program which lowered the upfront cost of connections. Consequently, most of the connected households are either located in the town center where most of the business activities take place, or in the vicinity of schools, hospitals, or dispensaries and county government buildings, but also the areas surrounding the town are slowly benefiting from the ramp-up in electricity access.

Water access is the primary issue of the population residing in the town. The water table is very deep, due to the characteristics of the volcanic soil, and the main source of water are shallow wells in the forests, water boozers coming from boreholes in the nearby settlements or through water harvesting.

National government programs focusing on floods and droughts resilience were already deployed before devolution, but through the county government presence in the town, the solutions have been increasingly adapted to the specific context collaborating directly with the NGOs operating locally, local associations and cooperatives. Numerous projects and training programs have been carried out on water harvesting, water management, and small-scale agriculture as focused programs on seeds restocking and drought-resistant crops.

## **Illaut**

Illaut is a town located in the south-western part of Marsabit, near the border with Samburu county. Illaut, after the rehabilitation of the existing Laisamis–Ngurunit–Illaut–South Horr–Loiyangalani road, funded by the African Development Bank and the Government of the Netherlands to connect the Wind Farm developed on the shore of Lake Turkana, became a central point of connection for all the surrounding areas. The chief of Illaut is responsible for everyone living in all the nearby villages.

In consideration of its relevance, Illaut has been selected as one of 26 sites for the installation of hybrid mini-grids by REREC (REREC 2019). The system was commissioned in October 2019, with around 20 customers connected (two shops, one church, and one dispensary plus households). Due to the lack of Internet connectivity, the smart-metering system is still not operating at the present time, while power generation and consumption is steady. Having network access is in fact mandatory for the KP metering systems, as to collect the revenues, monitor consumption, and bill collection is a big hurdle for most of the new hybrid mini-grids operated by Kenya Power. However, Safaricom started building a repeater tower in the end of 2019, which is supposed to start working during spring 2020, to grant network access to the Illaut and the nearby villages. Access to the network has been proven to bring direct economic and social benefits for everyone: mobile and Internet services have a transformational impact, offering life-enhancing financial and health services, as well as the simple ability to enhance communication within families and within the whole community.

Most of the houses are made out of bricks and the Tuesday market became the main trading post for goods coming from Meru and Nairobi, through Marsabit and Nyeri, and for local handmade products. The presence of a nearby shallow well provides access to water that has to be treated to be drinkable. This is not perennial and depends on rainfall, making it hard for people to access water during the long-lasting dry season.

Firewood is the primary source for cooking, followed by charcoal. In Illaut town local government is creating awareness regarding the negative that open fire has on the health of mainly women and children.

In the end of 2019 the county government, following the access to water plan of the Water Resources Management Authority (WARMA), started building a borehole in the town that will be completed in early 2020. Thanks to this borehole the town, and the nearby settlements, can have access to clean water that can be used for irrigation and cattle survival during the dry season. The chief of the village, together with key personalities of the community, has been engaging both the farmer communities in Marsabit and Laisamis, NGOs like PACIDA, and some SACCOs to obtain training, seedlings, and agriculture machines to open up the possibility of unlocking the potential of local farmers.

Illaut can be considered as an example of sustainable development and climate change resilience through the TH model, due to:

- Improvement of the infrastructure by the government (Laisamis-Loiyangalani road funded by AfDB).
- Electrification through a hybrid system by REREC (60 kW) (Rural Electrification Master Plan).
- Construction of a borehole and installation of a pumping system for human and agriculture use by the county government (WARMA access to clean water program).
- Installation of a repeater for the network access by Safaricom (private company intervention).

---

## Laisamis

Laisamis is the main town of Laisamis constituency. It is situated between Merile and Log-logo, on the road from Isiolo to Marsabit Town. In Laisamis most of the buildings are made out of bricks, but most of the people in the surrounding areas are living in huts. Along the road there is the presence of schools, hospitals, shops, hotels, and other business which are benefiting from affordable and reliable energy access.

Laisamis is served by a hybrid mini-grid commissioned by REREC in 2015 that currently serves 170 connected customers, mostly concentrated around the tarmac road and near the town center, where the majority of shops and activities are located. The system that combines 264 kW of diesel generators, 80 kW of solar photovoltaic, and a battery storage system experienced a significant growth of connections thanks to the implementation of the last-mile project. Furthermore, an expansion of the system to reach the communities of Log-logo and Merille started 2 years ago, and the main distribution infrastructure, transformers, and low voltage lines have been put in place in early 2020, but are not yet operational.

Merille and Log-Logo are two urban centers located, respectively, 23 km south and 47 km North of Laisamis. In both towns there is presence of numerous boreholes that are powered by PV systems or diesel generators for shops, dispensaries, and schools. The interconnection of the systems foresees the installation of an additional 500 kW diesel generator to provide adequate electricity supply. This is creating a big opportunity for people to benefit from energy access through income-generating activities.

In Laisamis, access to water is granted by a seasonal river and different private and public boreholes scattered around town. In fact, the water table is not deep, and as results of surveys by the county government and WARMA suggest there is a good potential to dig boreholes. During dry season the sources of water, for the majority of the people, are two public boreholes in the north west of the main settlement, where they can access water for free, but in limited quantities. The salinity level of the water extracted is high and has to be treated accordingly.

---

## Discussion

The selected case studies in Marsabit are evaluated with respect to the theoretical framework laid out in section “The Triple Helix,” and in consideration of the literature review detailed in section “Energy Access and Climate Change in Kenya.” Although the analysis has been carried out for Marsabit County, a great part of it can be replicated in the other 13 underserved counties identified by KOSAP.

An interesting aspect of this ecosystem is that NGOs have been attempting to improve local conditions by capacity building which can be done by locally present technical schools, vocational training centers, and Technical and Vocational Education Training (TVET) centers. In the proposed cases, in fact, NGOs have developed projects on agriculture and drought resilience species. It was also noted that some electrification activities have also been directly promoted by NGOs, but some projects have failed because the system has not been maintained. Here is when one sees

the difference between NGOs and private sector partners. The latter will not leave as long as there is a market for the goods or services rendered.

In the three case studies reported above, water pumping from boreholes or close water sources is significant priority and is usually performed when the village is electrified and water is available nearby. The devolution that started taking place in 2013 has actually helped the county in addressing these problems.

The positive example of Laisamis has shown that combining energy with a safe source of water for people and animals has reduced the nomadism of the area, thus making the electric system more sustainable. Another useful information is an accurate estimate of the population able and willing to purchase energy from the mini-grid. As a matter of fact, load assessment is one of the most critical challenges in mini-grid development.

From the case study analysis, it appears that there is a growing attention in policymaking to the transversally and interdependence of key rural challenges such as energy access, climate change adaptation, and water and food security. Even if not explicitly mentioned, partial references to the TH approach are each day more present in the planning phase though the “silo mentality” that persists.

Education plays a significant role in terms of both enhancing awareness of technologies, opportunities, safe practices, and hygiene in the area and developing skills to promote growth. Currently there are eight vocational training centers (VTCs) in the county that provide above-basic education, four of them instituted by the county government. These centers nonetheless are not yet accredited by the Technical and Vocational Education and Training Authority (TVETA).

It is worth noticing the case of Illaut in which a repeater has been installed shortly after the mini-grid was installed. In fact, people look for connection as a modern mini-grid operator needs connectivity to operate, monitor, and manage the smart-metering system.

Considering this, universities can support and study all the above and identify best practices as well promote new solution to tackle the issues. For example, in Laisamis, the electricity service suffers from poor quality and outages, and the system will be soon enlarged to electrify the nearby villages. However, this may lead to increased number of outages and reduced quality given the long lines to reach the communities. This could be an opportunity for a university research center to provide support by analyzing the data in the field and promoting innovation also by field experience (mode 2). Social data combined with electrical data from the villages can be analyzed in order to estimate and promote the major determinants for load growth and even support the expansion of the mini-grid (Lee et al. 2014).

From the literature review on the TH, it is evident that when government, university, and industry work together in good coordination, rural electrification and climate change adaptation problems are easier to solve.

In a society in which innovation is one of the major drivers for growth, a good application of TH to rural electrification can be not only a promising solution but also promote growth by developing innovation in a challenging and new sector in which few players operate. Besides, electricity provided by decentralized solutions such as mini-grids can be not only an economic solution for areas but provide services that can help people to stop the nomadic lifestyle. Many Turkana people are building permanent houses where the wives and children can stay in a place and



profit from education, health service, and electricity while their husbands move around in search of water and grazing fields for their animals.

Rural electrification is a very risky business and rarely can achieve bankability without external funds. However, it brings significant benefits to society in terms of externalities such as local growth, the development of business activities, higher education for children, improved healthcare conditions, and connectivity, to quote but a few services. Therefore, the public sector that looks at society as a whole should be interested in fostering activities and reduce barriers to rural electrification, with tools such as tax exemption, green line of credit, and grants by developing agencies.

The involvement of university in the process can promote innovation by pre-existing knowledge (mode 1), exploiting the field experience (mode 2), and also promoting capacity building for engineers, technicians, and students to provide the desired skills at county level. Therefore, alongside the “mode 2,” which justifies the recourse of case studies, the “mode 3” of knowledge production that is based on pluralism and diversity ought to be used.

Additionally, it turns out that the TH concept for rural electrification and climate change might be extended including civil society and concern for natural environment conservation, which have been included respectively as the fourth and fifth helices, respectively, in the work described in Carayannis et al. (2019). Also the concept of “bottom-up triple helix” (Haas et al. 2016) is a valuable contribution toward a better understanding of the role of connector agents, financing institutions, market facilitators, and knowledge brokers. In short, a TH intervention for the development of vulnerable areas promotes the joint action of several entities.

In fact, there is for local universities not only the need to improve their research standards and improvement of curriculums to go beyond the training of workforce but also the mandate to carry out the capacity building of technicians and governmental actors (Perez-Arriaga et al. 2018) and to act as knowledge brokers in order to reach the final rural beneficiaries. In this sense, if we consider that, for example, Nairobi and Marsabit town are located more than 500 km apart, connector agents are needed even within a country in order to promote innovation by experience (mode 2). This specific issue has been addressed in Da Silva et al. (2018) that describes an outreach program to train solar PV technicians on the standards of the Kenyan Energy Regulatory Commission (ERC). The project represents a multi-stakeholder interaction involving academia (Strathmore Energy Research Centre (SERC)), donor agencies (USAID, GIZ), regulatory institutions (National Industrial Training Authority (NITA), ERC) and technical training institutions (TTI) which through “training of trainers” received the capacitation from SERC to train technicians in locations distant from Nairobi.

---

## Conclusions

This chapter has shown that the collaboration of government, universities, and industry in a Triple Helix (TH) framework can be a promising tool for tackling rural electrification and climate change adaptation, using as example the Marsabit County, Kenya, case study.

One such lesson was the need to add to the traditional TH concept the civil society which can provide a soft landing for the private sector partner which at the initial stage may not see significant opportunities for business sustainability.

In modern knowledge-based society, the role of academia in promoting innovation is crucial, and rural electrification sector is not an exception. The university can identify best practices, develop research studies on the possible outcomes of different actions, and even support the development of novel devices, by working closely with the two other partners and having enough data to work with, which are very precious for the effectiveness of the studies.

In Marsabit, which is one of the least developed counties in Kenya, there have been limited examples of TH interventions, but the potential can be significant. Government can provide an adequate policy framework and/or fiscal stimulus, driven by the industry's needs, lowering barriers and reducing risks, after being discussed and agreed with the other stakeholders. Industry can make use of the innovation created by this environment and thrive, hence employing local people and boosting the economy.

The concepts discussed in this study can be useful for policy makers and players in the rural electrification, since they can be easily generalized for different areas in Kenya and Sub-Saharan Africa.

---

## References

- African Development Bank Group, Sustainable Energy For All – Africa Hub, Sustainable Energy Fund for Africa (2016) Green mini-grids in sub-Saharan Africa: analysis of barriers to growth and the potential role of the African Development Bank in supporting the sector. GMG MDP Doc Ser n 1
- Amaro N, Ruiz C, Fuentes JL et al (2014) Strategic contributions to extreme climate change: the innovation helixes as a link among the short, medium and long-terms. *Clim Chang Manag*:107–122. [https://doi.org/10.1007/978-3-319-04489-7\\_8](https://doi.org/10.1007/978-3-319-04489-7_8)
- Ambition to Action (2019) The role of renewable energy mini-grids in Kenya's electricity sector. Evidence of a cost-competitive option for rural. electrification and sustainable development
- Bagley C, Brown E, Campbell B, et al (2018) Mapping the UK Research & Innovation Landscape: Energy & Development
- Blodgett C, Dauenhauer P, Louie H, Kickham L (2017) Accuracy of energy-use surveys in predicting rural mini-grid user consumption. *Energy Sustain Dev* 41:88–105. <https://doi.org/10.1016/j.esd.2017.08.002>
- Bündnis Entwicklung Hilft (Alliance Development Works), United Nations University – Institute for Environment and Human Security (UNU-EHS) (2016) World Risk Report 2016
- Carayannis EG, Acikdilli G, Ziemnowicz C (2019) Creative destruction in international trade: insights from the quadruple and quintuple innovation Helix models. *J Knowl Econ*. <https://doi.org/10.1007/s13132-019-00599-z>
- Carayannis EG, Campbell DFJ (2010) Triple helix, quadruple helix and quintuple helix and how do knowledge, innovation and the environment relate to each other? A proposed framework for a trans-disciplinary analysis of sustainable development and social ecology. *Int J Soc Ecol Sustain Dev* 1:41–69. <https://doi.org/10.4018/jesd.2010010105>
- Da Silva I, Geoffrey R, Nalubega T, Njogu M (2018) Replacing fossil fuel with PV systems through technical capacity building in Kenya. In: Leal Filho W, Surroop D (eds) *The Nexus: energy, environment and climate change, green energy and technology*. Springer, Cham, pp 171–180

- Da Silva I, Wassler S (2011) Implementation of triple Helix clusters procedure in the sub-Sahara Africa energy sector. Case study: academia – CREEC photovoltaic laboratory. In: Conference MPDES 2011
- Dzisah J (2011) Mobilizing for development: putting the triple helix into action in Ghana. In: Saad M, Zawdie G (eds) Theory and practice of the triple Helix system in developing countries: issues and challenges. Routledge, New York, pp 146–160
- Energies Development (2018) Call for proposals for development of solar PV hybrid mini-grids in Marsabit county
- Etzkowitz H (2008) The triple Helix: university-industry-government innovation in action. Routledge, New York
- Etzkowitz H (2003) Innovation in innovation: the triple Helix of university – industry – government relations. *Soc Sci Inf* 42:293–337. <https://doi.org/10.1023/A:1026276308287>
- Etzkowitz H (2012) Silicon Valley: the sustainability of an innovative region. *Soc Sci Inf* 52:1–25. <https://doi.org/10.1177/0539018413501946>
- Etzkowitz H, Zhou C (2006) Triple Helix twins: innovation and sustainability. *Sci Public Policy* 33:77–83. <https://doi.org/10.3152/147154306781779154>
- FAO (2017) Resilience analysis in Isiolo, Marsabit and Meru. *Anal Resil Target Action* FAO Resil Anal 9
- FAO (2019) Food security and nutrition in the world
- Franz M, Peterschmidt N, Rohrer M, Kondev B (2014) Mini-grid policy toolkit
- Fraval S, Hammond J, Bogard JR et al (2019) Food access deficiencies in sub-saharan Africa: prevalence and implications for agricultural interventions. *Front Sustain Food Syst* 3. <https://doi.org/10.3389/fsufs.2019.00104>
- Gambino V, Del Citto R, Cherubini P et al (2019) Methodology for the energy need assessment to effectively design and deploy mini-grids for rural electrification. *Energies* 12(12):574. <https://doi.org/10.3390/EN12030574>
- Gibbons M, Limoges C, Nowotny H et al (1994) The new production of knowledge. The dynamics of science and research in contemporary society. SAGE, London
- Global Water Partnership Easter Africa (GWPEA) (2015) Assessment of drought resilience frameworks in the horn of Africa. *Integr Drought Manag Progr Horn Africa (IDMP HOA)*
- Goldemberg J, Martinez-Gomez J, Sagar A, Smith KR (2018) Household air pollution, health, and climate change: cleaning the air. *Environ Res Lett* 13. <https://doi.org/10.1088/1748-9326/aaa49d>
- Government of Kenya (2016) Kenya National Adaptation Plan: 2015–2030
- Haas R, Meixner O, Petz M (2016) Enabling community-powered co-innovation by connecting rural stakeholders with global knowledge brokers: a case study from Nepal. *Br Food J* 118:1350–1369. <https://doi.org/10.1108/BFJ-10-2015-0398>
- IEA, IRENA, UNSD, et al (2019) Tracking SDG7: the energy Progress report
- International Energy Agency (IEA) (2019a) World energy outlook
- International Energy Agency (IEA) (2019b) Africa energy outlook 2019
- Kenya Food Security Steering Group (KFSSG), Marsabit County Steering Group (2017) Marsabit County 2017 long rains food security assessment report
- Kenya Ministry of Energy (2018) Kenya National Electrification Strategy: key highlights 2018
- Kenya National Bureau of Statistics (2019) Kenya Population and Housing Census. <https://www.knbs.or.ke/?p=5621>. Accessed 1 Mar 2020
- KETRACO (2018) KETRACO Grounbreaks Community Projects in Marsabit
- Kimatu JN (2015) Evolution of strategic interactions from the triple to quad helix innovation models for sustainable development in the era of globalization. *J Innov Entrep* 5:0–6. <https://doi.org/10.1186/s13731-016-0044-x>
- Kottász E, Draeck M (2017) Renewable energy-based mini-grids: the Unido experience
- KPLC, REA (2017) Kenya off-grid solar access project (KOSAP). Vulnerable & Marginalized Groups Framework
- Lake Turkana Wind Power Limited (2011) Addendum on Road Re-Alignment Environmental and Social Impact Assessment (ESIA) Report for the proposed Strengthening of Laisamis-South (D371) and South Horr- Loiyangalani (C77) Road

- Lee K, Brewer E, Christiano C et al (2014) Barriers to electrification for “under grid” households in rural Kenya. Center for Effective. Global Action, Berkeley
- Leydesdorff L, Etkowitz H (1995) The triple Helix – university-industry-government relations: a laboratory for knowledge base economics development. *EASST Rev* 14:14–19
- LTWP (2018) Lake Turkana wind power connected to the National Grid
- Marsabit County Government (2018) Climate change mainstreaming guidelines: water and sanitation sector
- Micangeli A, Del Citto R, Kiva I et al (2017) Energy production analysis and optimization of mini-grid in remote areas: the case study of Habaswein, Kenya. *Energies* 10:2041. <https://doi.org/10.3390/en10122041>
- Ministry of Energy (2018) The Kenya off-grid solar access project. K-OSAP
- Ministry of Energy (2019a) KOSAP List of 151 Minigrids – Status after Field Survey (2)- Final (3)
- Ministry of Energy (2019b) KOSAP Public Facilities by County - Status Final after Survey (3)
- Ministry of Planning and National Development K (2007) Kenya vision 2030: a competitive and prosperous Kenya
- Moore A, Nyangoma V, Du Toit J et al (2015) Rwandan collaborative model for educator capacity building. *ICSIT 2018 – 9th Int Conf Soc Inf Technol Proc* 16:167–172
- Murphy B, Corbyn D (2013) Energy and adaptation. Exploring how energy access can enable climate change adaptation. *Pract Action Consult*
- Ngigi S, Busolo D (2019) Devolution in Kenya: the good, the bad and the ugly. *Public Policy Adm Res* 9:9–21. <https://doi.org/10.7176/PPAR>
- Nygaard I, Gichungi H, Hebo Larsen T, et al (2018) Market for integration of smaller wind turbines in mini-grids in Kenya
- Outamba R, Belhcen L (2020) What do we know about university-industry linkages in Africa? In: Abu-tair A, Abdelmounaim L, Khalid AM, Bassam A-H (eds) *Proceedings of the II international triple Helix summit. Lecture notes in Civil Engineering Volume, vol 43*. Springer, Cham, pp 375–391
- Perez-Arriaga I, Micangeli A, Sisul M (2018) Unleashing sustainable human capital through innovative capacity the micro-Grid’s potential the micro-grid academy can unlock building and vocational training: in East Africa. *Unlocking value from. Sustain Renew Energy*:100–105
- Republic of Kenya (2019) The energy act, 2019. *Kenya Gaz Suppl*
- Republic of Kenya – The National Treasury and Planning (2018) Third medium term plan 2018–2022. *Transforming lives: advancing socio-economic development through the “big four”*
- Republic of Kenya County government of Marsabit (2018), Second County integrated development plan 2018–2022
- Republic of Kenya, County Government of Marsabit (2015) Revised First County Integrated Development Plan (2013-2017)
- REREC (2019) Successor of rural electrification authority is now established. Rural Electrification Authority is now REREC
- Res4Africa (2019) Water-Energy-Food Nexus – RES4Africa Foundation. <https://www.res4africa.org/water-energy-food-nexus/>. Accessed 21 Oct 2019
- Rural Electrification Authority (REA) (2008) Strategic plan 2008–2012
- Smith KR, Bruce N, Balakrishnan K et al (2014) Millions dead: how do we know and what does it mean? Methods used in the comparative risk assessment of household air pollution. *Annu Rev Public Health* 35:185–206. <https://doi.org/10.1146/annurev-publhealth-032013-182356>
- The Ministry of Agriculture Livestock and Fisheries (MoALF) (2017) Climate risk profile for Marsabit County. Kenya County climate risk profile series. Nairobi
- Trenberth KE, Dai A, van der SG et al (2014) Global warming and changes in drought. *Nat Clim Chang* 4:17–22
- Trencher G, Yarime M, McCormick KB et al (2014) Beyond the third mission: exploring the emerging university function of co-creation for sustainability. *Sci Public Policy* 41:151–179. <https://doi.org/10.1093/scipol/sct044>
- UNICEF (2017) Situation analysis of children and women in KENYA. 224

- UNICEF, WHO (2019) Progress on drinking water, sanitation and hygiene. Who:1–66. <https://doi.org/10.1111/tmi.12329>
- Wiesmann U, Kiteme B, Mwangi Z (2016) Socio-Economic Atlas of Kenya: Depicting the National Population Census by County and Sub-Location
- World Bank (2020) Kenya Data. <https://data.worldbank.org/country/kenya>. Accessed 28 Mar 2020
- Zhang J, Deng S, Shen F et al (2011) Modeling the relationship between energy consumption and economy development in China. *Energy* 36:4227–4234. <https://doi.org/10.1016/j.energy.2011.04.021>

**Open Access** This chapter is licensed under the terms of the Creative Commons Attribution 4.0 International License (<http://creativecommons.org/licenses/by/4.0/>), which permits use, sharing, adaptation, distribution and reproduction in any medium or format, as long as you give appropriate credit to the original author(s) and the source, provide a link to the Creative Commons license and indicate if changes were made.

The images or other third party material in this chapter are included in the chapter's Creative Commons license, unless indicated otherwise in a credit line to the material. If material is not included in the chapter's Creative Commons license and your intended use is not permitted by statutory regulation or exceeds the permitted use, you will need to obtain permission directly from the copyright holder.





# Climate Change Adaptation Mechanism for Sustainable Development Goal 1 in Nigeria: Legal Imperative

93

Erimma Gloria Orié

## Contents

Introduction .....	1898
Conceptual Clarification .....	1900
Nexus Between CC Adaptation Mechanism and Poverty (SDG 1) .....	1902
Global Efforts to Combat Poverty Through Adaptation Mechanism .....	1904
Policy, Legal, and Institutional Frameworks for Fighting Poverty in Nigeria .....	1906
Legal Issues, Challenges, and Strategies in the Application of Climate Change Adaptation Mechanism .....	1908
Conclusion and Recommendation .....	1913
References .....	1914

## Abstract

Despite international efforts on poverty reduction in the last decade, poverty is rampant in many countries including Nigeria. Poverty remains a principal challenge for development in twenty-first century and a threat to achievement of Sustainable Development Goal (SDG) 1, which is a global attempt, among others, to end poverty by 2030. Meanwhile, 13 out of the 15 countries where extreme poverty is rising are in Africa. According to the World Poverty Clock, Nigeria, by 2018, had the largest extreme poverty population of 86.9 million, thus making the people vulnerable to malnutrition, armed conflict, migration, and other socioeconomic and environmental shocks. Whereas these impacts are exacerbated by climate change (CC), unfortunately, Nigeria's adaptation efforts are inadequate due to certain impediments. The chapter finds that Nigeria lacks the CC law to properly regulate institutional and policy interventions to impacts of CC. It argues that although adaptation as opposed to mitigation is interim, yet integrating adaptation measures into Sustainable Development (SD) framework and poverty reduction strategies is a potent means of addressing CC impacts on the poor and achieve SDG1 target. The chapter therefore recommends the establishment of CC

E. G. Orié (✉)

Department of Private and Property Law, National Open University of Nigeria, Abuja, Nigeria

© The Author(s) 2021

W. Leal Filho et al. (eds.), *African Handbook of Climate Change Adaptation*,  
[https://doi.org/10.1007/978-3-030-45106-6\\_81](https://doi.org/10.1007/978-3-030-45106-6_81)

1897

law in Nigeria that incorporates adaptation measures in poverty reduction strategies and mainstreaming of CC issues.

---

**Keywords**

Poverty · Adaptation · Sustainable development (SD) · Sustainable Development Goals (SDGs) · Climate change (CC)

---

## Introduction

Since the turn of the twenty-first century, there has been an unrivaled concern of the international community to achieve sustainable development (SD). From Stockholm Declaration through Rio +10, Agenda 21 to the United Nations Conference on Sustainable Development held in Rio 2012, and the Millennium Development Goals (MDGs), the Paris Agreement, and the recent UN Conference of Parties (COP 24) at Bonn, Germany, the focus has been to combat environmental damage and reduce poverty and diseases through global cooperation on common interests, mutual needs, and shared responsibilities. Even the United Nations 2030 Agenda for Sustainable Development is an action plan focused on people, planet, prosperity, peace, and partnership (5Ps) with a mandate that no one should be left behind. The first Sustainable Development Goals' Report published in 2016 (Portugal 2016) reveals that about 1 in every 8 persons in the world still lives in extreme poverty; some 800 million people are suffering from hunger; the birth of nearly 1 in 4 children under the age of 5 years is still unregistered; women spend about 2.4 times more hours per day on caregiving and household tasks than men; 1.1 billion people live without electricity; and that water scarcity now affects more than 2 billion people in the world (Ibid). Furthermore, the UN has launched the 2018 version of the yearly Sustainable Development Goals (SDGs) Report (SDG Report 2018) which finds that conflict, climate change, and inequality are major factors in growing hunger and displacement, and are hindering progress toward the SDGs. The implication of these reports is that the world, particularly Africa and of course, Nigeria, is not on course to ending poverty at least by 2030. This could undermine the attainment of SDG 1 which deals with poverty reduction.

The major objective of the World Bank since the 1970s has equally been to reduce poverty. In 2013, the World Bank Group announced two all-embracing goals: the end of chronic extreme poverty by 2030; the promotion of shared prosperity, defined in terms of economic growth of the poorest segments of society (to reduce extreme poverty to 3% of the world population by 2030 and, for the first time, including a distributional goal, "share prosperity" by promoting the income growth of the poorest 40%). However, the global proportion of people living in extreme poverty is three times lower than in 1970; it fell from 43% in 1990 to 19% in 2010 and further to 17% in 2011 (Ending Extreme Poverty 2013).

Despite commitments to inclusive, pro-poor, and broad-based growth, the poorest 20% of people still receive just 1% of global income causing the gap between the

poorest 20% and everyone else to continue to widen. Indeed, 13 out of the 15 countries where extreme poverty is rising are in Africa. According to the World Poverty Clock, by 2018, Nigeria had the largest extreme poverty population of 86.9 million due to drought, flood, heatwaves, ocean surges, reduction in crop yield, decreased fresh water availability, disruption of economic activities, destruction of infrastructure, etc. These challenges are exacerbated by the impact of climate change (Orie 2015), the end state of which is that the people are made vulnerable to malnutrition, armed conflict, migration, and other socioeconomic and environmental shocks. The National Bureau of Statistics figures showed that poverty incidence worsened between 2004 and 2010, despite impressive growth record over this period (Olofin et al. 2015). Poor farmers also risk losing crops as the flood season occurs when crops ripen for harvest. In the longer term, poor households also risk losing wage opportunities as the sick and injured cannot work or as the disaster destroys the need for labor. Recovery strategies, like selling assets, can leave the poor without income and thus more vulnerable.

Nigeria's extreme poverty population of 86.9 million can be scary. Specifically, for Lagos, Osun, Anambra, Ekiti, Edo, Imo, Abia, and Rivers States, the poverty level hovers between 8.5 and 21.1%; Plateau, Nassarawa, Ebonyi, Kaduna, Adamawa, and Benue States have poverty level that hovers between 51.6 and 59.2%, while the poverty level for Niger, Borno, Kano, Gombe, Taraba, Katsina, Sokoto, Kebbi, Bauchi, Jigawa, Yobe, and Zamfara States hovers between 61.2 and 91.9% (Olawale 2018). Certainly, these degrees of poverty make the people vulnerable to malnutrition, armed conflict, migration, and other socioeconomic and environmental shocks. Whereas these impacts are exacerbated by climate change, unfortunately, Nigeria's adaptation efforts to counter poverty are inadequate due to certain legal impediments. Nigeria, for instance, lacks the climate change law to properly regulate institutional and policy interventions to impacts of climate change. The crux of the matter is that without a legally binding framework, integrating adaptation measures into SD framework and poverty reduction strategies, it will be difficult to address climate change impacts on the poor and achieve SDG1 target. Moreover, the commitment to all-inclusive zero poverty has no global or national framework of measurement. These are some of the challenges Nigeria has been grappling with and must overcome in order to attain SDG 1 target. Perhaps, leveraging international best practices, the establishment of climate change law in Nigeria that incorporates adaptation measures in poverty reduction strategies could present a way forward and that is the motivation and what this chapter purposes to achieve. The chapter is limited mostly to document analyses of the relevant UN and other international conventions/documentations as well as national policies on the subject matter in the last decade when climate change, MDG, and SDG issues assumed more global attention and priority. The focus of this work remains the legal dimensions to Nigeria's efforts regarding climate change adaptation mechanism.

Therefore, the chapter begins with conceptual clarifications of key words to set the work in proper perspective leading to establishment of nexus between climate change adaptation and poverty. This is followed by a highlight of global efforts to



combat poverty through Adaptation mechanism. Next is an examination of the policy, legal, and institutional framework for fighting poverty in Nigeria leading to a discussion on the legal issues, challenges, as well as strategies in the application of climate change adaptation mechanism to achieve SDG 1. Thereafter the chapter concludes with salient recommendations.

## Conceptual Clarification

It is necessary to conceptualize the key words in order to put the paper in proper perspective and to aid understanding. The words and phrases to be conceptualized are climate change, sustainable development, adaptation, and poverty.

### Climate Change

The United Nations Framework Convention on Climate Change (UNFCCC) defines climate change as a change of climate which is attributed directly or indirectly to human activity that alters the composition of the global atmosphere and which is in addition to natural climate variability observed over comparable time periods (UNFCCC Art 1.2). The impact of climate change include rise in sea levels, rise in temperature, and change in weather patterns resulting in decline in overall biodiversity, implications for agriculture and food security, human health, unpredictable rain pattern and floods, prolonged drought and subsequent crop failures, water shortages, and homelessness (Orie 2017).

### Sustainable Development

Sustainable development is the universally adopted plan to promote prosperity and social well-being while protecting the environment. The 2030 Agenda for SD is “our shared vision of humanity and a social contract between the world’s leaders and the people” (Ban Ki-Moon), which sets an ambitious but achievable, universal, and holistic agenda for all. As a universal agenda, based on 17 SDGs and 169 targets to be implemented by all countries, the 2030 Agenda calls for the integration of the SDGs into the policies, procedures, and actions developed at the national, regional, and global levels. There is a clear call for action to dramatically scale up development finance and improve the development impact of all financial flows. But its goals are at risk of not being realized as the gap between the poorest people and the rest of the world continues to widen.

In several ways, the SDGs brought a novel tactic to the manner in which the world approaches the subject matter of development. These include, for example:

- (i) Integrating the three dimensions of SD (economic, social, and environmental).
- (ii) Being based on universal goals and targets to be implemented by all countries (and not only by developing countries).
- (iii) Having a greater potential for tackling inequality and promoting human rights as a cross-cutting concern across all SDGs.

- (iv) Involving new dynamic concerted efforts from a wide range of actors, including nongovernmental organizations (NGOs), the private corporate sector, academia, social partners, and other members of civil society, including the cooperation between parliament, government, regional, and local authorities. In fact, this is a challenge which concerns us all ([Portugal](#)).

### **Adaptation**

The term adaptation according to the UNFCCC refers to “adjustments in ecological-social-economic systems in response to actual or expected climatic stimuli, their effects or impacts, and the building of a climate-resilient society that is able to withstand or recover quickly from difficult conditions caused by the adverse effects of climate change” (Medugu et al. [2011](#)). Examples of adaptations include building flood defenses, planning for heat waves and higher temperatures, and installing water-permeable pavements to better deal with floods and storm water and improving water storage and use (Ibid; [Orie 2015](#)). Adaptation also encompasses making the most of any potential beneficial opportunities associated with climate change (for example, longer growing seasons or increased yields in some regions) (global climate change). However, the major challenge to adaptation includes the fact that adaptation is fundamentally about climate change risk management, and it is not a long-term solution, hence the need for reinforcement which mitigation offers ([IPCC report](#)).

A major benefit of adaptation is the fact that it is usually imbued with the prospects of reducing the negative impacts of climate change. However, the capacity to adapt is principally a factor of the socio-economic characteristics, and the likelihood of adaptation needs to be carefully analyzed given the peculiar circumstances of the developing countries and their obvious disadvantage with respect to technological, financial, and institutional provisions ([McGuigan et al. 2002](#)).

### **Poverty**

The World Bank defines extreme poverty as living on less than 1.90 international dollars (int.\$) ([Roser and Ortiz-Ospina 2019](#)). Poverty is the result of economic, political, and social processes that interact and frequently reinforce each other in ways that exacerbate the deprivation in which poor people live (Ibid). The United Nations has also now declared the eradication of poverty by 2030 as a primary development goal. Poverty is at the same time stark and conceptually elusive, especially when we try to track it statistically across nations and over time. The World Bank Group has been at the vanguard of developing measures of living standards and it sets the International Poverty Line (IPL). The poverty line was revised in 2015 and since then persons are considered to be in extreme poverty if they live on less than 1.90 (int.-\$) per day. The measurement of this poverty is based on the monetary value of a person’s consumption while the application of income measures is employed for countries without available reliable consumption measures ([World Bank 2015](#)). Alternative starting points for measuring welfare include subjective views (e.g., self-reported life satisfaction), basic needs (e.g., caloric

requirements), capabilities (e.g., access to education), and minimum rights (e.g., human rights) (Ibid). There is also the national accounts method to estimate poverty which is based on academic studies that reconstruct historical income levels from cross-country macro estimates on economic output and inequality. Therefore, while the IPL is useful for understanding the changes in living conditions of the very poorest of the world, one must also take into account higher poverty lines reflecting the fact that living conditions at higher thresholds or well above the IPL can still constitute a destitute.

---

## **Nexus Between CC Adaptation Mechanism and Poverty (SDG 1)**

The 2007 and 2014 IPCC reports state that due to the effect of climate change, both distributional impacts of increased temperature and precipitation changes will vary from region to region, affecting higher and lower latitudes disparagingly and asymmetrically (IPCC Fourth Assessment Report). The IPCC Report predicts further that global warming resulting from carbon emissions will cause a rise in sea levels and may lead to an increase in the frequency and severity of natural disasters. In addition, incidences of natural disasters such as droughts and floods, which affect agricultural production, fisheries and marine life, water resource availability, industry, and human health will continue to be on the increase and indeed exacerbated by climate change.

Coastal areas are most at risk to the changes outlined above. Increased sea levels will bring salinization and an intrusion of seawater into freshwater sources, flooding and loss of land, erosion, loss of wetlands and mangroves, and loss of soil fertility. Furthermore, changes in temperature will alter ocean circulation patterns, vertical mixing of water and wave patterns which will impact on marine productivity, availability of nutrients, and disturb the structure of marine and coastal ecosystems (IPCC 2001). While there is no data on the frequency of disasters due to climate change, Messer estimates that with a 70 cm sea level rise, the number of people at risk of annual flooding could increase from 46 million to 90 million. With such disasters come the urge need for interim relief assistance (like artificial irrigation in drought areas) to enable the people adjust to the impact of the disaster. Thus, adaptation enables the victims to access immediate and or interim assistance as opposed to a long-term relief which mitigation provides (Messer 2003).

Furthermore, the disasters are expected to increase the disparity in wealth between the developed and developing world, and redistributive impact is one of the major reasons for concern about the climate change phenomena as expressed by the IPCC in its 2001 report. Due to these differential effects, developing countries like Nigeria are likely to suffer more from the economic impacts of climate change, as well as being the least able to adapt to new climatic conditions. Moreover, poorer communities also have limited means to cope with the losses and damage inflicted by natural disasters. Lack of adaptation option like insurance policies, savings, or credit make it almost impossible to replace or compensate for the numerous things lost or destroyed, including houses, livestock, food reserves, household items, and

tools (IPCC 2001), which in turn will threaten the chances of effective reduction in poverty level.

Developing countries often do not have the resources for these and consequently are ill-prepared in terms of coastal protection, early warning and disaster response systems, and victim relief and recovery assistance, hence the disproportionate level of climatic impact. For example, it has been asserted in some quarters that even when developed countries experience a larger proportion of property damage (75%), that recovery costs are higher for developing countries. Also, that whilst developed countries pay 0.1% of GDP in losses, developing countries pay 2–3%, or sometimes as much as 15% as seen with hurricanes in the Caribbean (Gurtner 2010). Developing countries also experience greater loss of life, about 90% of all deaths (Bankoff 1999). For example, the risk of drowning in Fiji due to dyke failure is one in 100,000, whereas in the Netherlands it is one in ten million (Olsthoorn et al. 1999). Notwithstanding the degree of risks exacerbated by climate change for these poor and marginalized populations, lots of uncertainties exist for developing countries regarding scientific predictions, levels of vulnerability, and the ability to adapt to these developments. Recent estimates suggest that, in the absence of adaptation, climate change could result in a loss of between 2% and 11% of Nigeria's GDP by 2020, rising to between 6% and 30% by the year 2050. This loss is equivalent to between N15 trillion (US\$100 billion) and N69 trillion (US\$460 billion) (National adaptation strategy). Several legal barriers, poor access to location, lack of services and infrastructure, and poor building structures all increase the vulnerability to flooding, storm surges, drought, and rain. The result is the accentuation of poverty, hunger, lack of quality education, gender inequality, loss of basic shelter, and jobs. These challenges are a threat to both the global and national efforts toward the attainment of the SDGs especially that of eradicating poverty.

The SDGs comprise 17 goals spliced into 169 targets. For example, the focus of SDG #1 is to end poverty and SDG #2 is to end hunger. Poverty breeds hunger which in turn affects the general well-being of a person by reducing the coping capacity to environmental challenges. A poor man is usually hungry and thus cannot achieve SDG #3 which is on well-being. When the stomach is empty, nothing can enter the brain, but if the first three goals are achieved, one can make use of SDG #4 Quality Education and learn to respect others and internalize SDG #5 Gender Equality. Thus, the SDGs are interrelated and interconnected.

It has been noted that giving priority to SD and meeting the SDGs is in tandem with efforts to adapt to climate change. When SD promotes livelihood security, it enhances the adaptive capacities of vulnerable communities and households. Examples include SDG 2 and its targets that promote adaptation in agricultural and food systems (Lipper et al. 2014) and SDG 11 which supports adaptation in cities to reduce harm from disasters (Kelman 2017). The overall success of SDGs 2 and 11 will assist in reducing poverty which is SDG 1. Indeed it has been submitted by various scholars that a well-integrated adaptation supports sustainable development (Weisser 2014). Substantial synergies are observed in the agricultural and health sectors and in ecosystem-based adaptations. However, a particular adaptation strategy can equally lead to adverse consequences for developmental outcomes.

Furthermore, adaptation strategies that advance one SDG can result in tradeoffs with other SDGs. For instance, agricultural adaptation to enhance food security (SDG 2) causes negative impacts on health, equality, and healthy ecosystems (SDGs 3, 5, 6, 10, 14 and 15). Notwithstanding this important role that adaptation could play to ensure that achievement of SDG 1 remains on course, Nigeria has no climate change law for the implementation of adaptation policy to achieve SDG 1. This is quite a challenge that must be addressed in order to make progress.

This segment has so far established the nexus between climate change adaptation and poverty. It has argued that incidences of natural disasters such as droughts, floods desertification, etc. which continue to increase and indeed are exacerbated by climate change can be checkmated, albeit, in the interim by adaptation measures to ensure the eradication of poverty (attainment of SDG 1) by 2030. In the case of Nigeria, it is therefore imperative that her adaptation measures are strengthened legally to ensure that the stated target is achieved. The next section will examine the global perspective to this.

### **Global Efforts to Combat Poverty Through Adaptation Mechanism**

There is increasing global efforts to address poverty based on our interconnectedness as peoples living on mother earth and the understanding of the need to save the environment for use by future generations. From around 1820, there was widespread poverty with more than a billion people that lived in extreme poverty, but this has changed over the last two centuries due mainly to economic growth notwithstanding that the population increased sevenfold over the same period. According to these household surveys, 44% of the world population lived in absolute poverty in 1981, whereas in 32 years, the share of people living in extreme poverty was divided by 4, reaching levels below 11% in 2013. There were 2.2 billion people living in extreme poverty in 1970, while people living in extreme poverty in 2015 were 705 million (Roser and Ortiz-Ospina 2019).

The global incidence of extreme poverty has gone down from almost 100% in the nineteenth century to 10.7% in 2013. Some analysts have submitted that this substantial reduction of global poverty is not unconnected with the poverty reduction in China where in 1981 almost one third (29%) of the non-Chinese world population was living in extreme poverty, but by 2013, this share had fallen to 12%. Others believe it has to do with sustained economic growth, driven by industrial development and their ability to benefit from globalization. While this is a great achievement, there is absolutely no reason to be complacent: a poverty rate of 10.7% means a total poverty headcount of about 746 million people (Ibid). The breakdown by continent is as follows: 383 million in Africa, 327 million in Asia, 19 million in South America, 13 million in North America, 2.5 million in Oceania, and 0.7 million in Europe. Africa is the continent with the largest number of people living in extreme poverty. On the other hand, India is the country with the largest number of people living in extreme poverty (218 million people), while Nigeria and the Congo (DRC) follow with 86 and 55 million people, respectively (Ibid).

In line with the global fight against poverty, it has been suggested in some quarters that the most direct method to measure poverty is to use the poverty headcount ratio. This method requires the setting up of a poverty line and then counting the number of people living with incomes or consumption levels below that poverty line. A major advantage of this system is that it offers information that is candid to interpret; by definition, it shows the percentage of the population living with consumption (or incomes) below some minimum level (Ibid).

The World Bank Group has also published a new set of poverty estimates, as part of their report on poverty and shared prosperity. These estimates, explained in details in two related background papers (Ibid), are consistent with the official World Bank poverty figures published in Povcal and the World Development Indicators, but they are disaggregated by key demographic characteristics such as age and educational attainment. Furthermore, the UN projection through the SDGs is an extremely ambitious target of ending extreme poverty by 2030, a target which many analysts have observed is likely to require growth with declining inequality. Globally, many governments tend to adopt short-term interventions programs as a means of reducing poverty. In fact, a multilayered program offering short-term support along various household dimensions has been shown to cause lasting progress for the very poor in six different countries. This intervention comprises six elements; a productive asset grant, temporary cash consumption support, technical skills training, high frequency home visits, a savings program, as well as health education and services.

Regionally, the European Union in a show of commitment to the SD across borders published, through the European Commission on November 22, 2016, a Communication on the “*Next steps for a sustainable European future*” that sets out how the 2030 Agenda is to be implemented within the EU. This internal implementation of the Agenda includes two work streams: the first is to fully integrate the SDGs in the European policy framework and the Juncker Commission’s ten priorities for its current term, identifying the most relevant sustainability concerns, and also assessing European policies and the efforts to achieve the 17 Goals, while the second one will work on further developing a long-term European vision and focus on sector-based policies after 2020 which will enable the long-term implementation of the SDGs. The new Multiannual Financial Framework beyond 2020 shall also reorient the EU budget’s contributions toward that same end (Ibid). Furthermore, for the external implementation of the 2030 Agenda, the Commission also presented on November 22, 2016 a communication on the review of the European Consensus on Development (2017), seeking to adapt the development policy of the EU to the new international development architecture. European Consensus was adopted in 2017, and it is organized around the 5Ps of the Agenda 2030. It is expected to impact on the elaboration of development instruments and programs of the EU and its Member States, fostering their alignment with the SDGs and the Addis Ababa Action Agenda (Addis Ababa 2015).

The implementation of the Agenda at the national level brings new challenges which require some reshaping of institutional models to reflect and meet the inherent cross-sector coordination requirements. In this process, it is also relevant to create mechanisms that provide the necessary coordination between the various

institutional stakeholders, with a view to present progress reports in a number of different fora in which the implementation of the 2030 Agenda is discussed. On the other hand, the EU's impact outside its borders is not limited to its external action agenda. Many EU policies contribute to the implementation of the SDGs worldwide. Therefore, achieving coherence across all EU policies is crucial to achieving the SDGs. With respect to bilateral and multilateral donor programs, the centerpiece of USAID's climate change policy is the Climate Change Initiative (CCI) with projects in three target areas, reducing GHGs, increasing developing countries' participation in UNFCCC, and decreasing vulnerability. The Canadian Government also established the Climate Change Development Fund (CCDF) in 2000, which allocates US\$100 million to assisting developing countries combat the causes and effects of climate change. The CCDF has four priority areas, namely emissions reduction, carbon sequestration, adaptation, and capacity building. Key recipients for the emission reduction include Brazil, China, Egypt, India, Kazakhstan, Nigeria, and South Africa (37–42% of funds), while the key recipients for adaptation are Bangladesh, sub-Saharan Africa, and Small Island States (10–15% of funds) (Climate change 2016). Thus, for Nigeria to remain a beneficiary of these foreign aids and attract foreign investment to complement her efforts, she must align her policy frameworks to SDGs to meet international standards in terms of harmonization of policies and legality of initiatives while keying into the priority project target areas set by donor countries and agencies.

In sum, poverty-induced climate change is widespread and has become a global phenomenon which requires international commitments for it to be curbed through adaptation mechanism. The aforementioned efforts have provided the global community with a template for the implementation of adaptation mechanism. In all of these, it will be interesting to examine how Nigeria has fared in employing adaptation mechanism, and this will form the subject of discussion for subsequent segments of this chapter.

## **Policy, Legal, and Institutional Frameworks for Fighting Poverty in Nigeria**

Nigeria can boast of numerous policies, legal, and institutional frameworks which directly and indirectly deal with climate change and poverty reduction. The frameworks for alleviating poverty in Nigeria include:

- (i) Nigeria's Constitution, particularly its Chaps. II and IV on the protection of citizen's right and the Directive principles of state policy.
- (ii) Nigeria Climate Change Policy Response and Strategy: The focus of the policy is to:
  - (a) Implement mitigation measures that will promote low carbon as well as sustainable and high economic growth
  - (b) Enhance national capacity to adapt to climate change

- (c) Strengthen national institutions and mechanisms (policy, legislative, and economic) to establish a suitable and functional framework for climate change governance
- (iii) The National Adaptation Strategy and Plan of Action on Climate Change for Nigeria (NASPA-CCN). This is the principal National Adaptation Strategy and Plan of Action on Climate Change for Nigeria. The objective of the policy is to integrate climate change adaptation into national, sectoral, state, and local government planning and into the plans of universities, research, and educational organizations, civil society organizations, the private sector, and the media; mobilize communities for climate change adaptation actions through the provision of appropriate user-friendly information; and reduce the impacts of climate change on key sectors and vulnerable communities, among others. Specifically, with respect to agriculture (crops and livestock), the policy seeks to adopt improved agricultural systems for both crops and livestock and to provide early warning/meteorological forecasts and related information.
- (iv) The National Policy on Environment which supports “the prevention and management of natural disasters such as floods, drought, and desertification.”
- (v) Nigeria’s Agricultural Policy whose objectives include the protection of “agricultural land resources from drought, desert encroachment, soil erosion, and floods.”
- (vi) The Nationally Determined Contributions (NDC) which is a determined contribution of Nigeria as regards her target of carbon emission reduction.
- (vii) Nigeria’s Drought Preparedness Plan.
- (viii) National Policy on Erosion and Flood Control.
- (ix) National Water Policy, National Forest Policy.
- (x) National Health Policy.
- (xi) Nigeria’s Sovereign Green Bond – Nigeria embraced the issuance of its Sovereign Green Bonds as an innovative and alternate way of raising finance both locally and internationally. This is a financing mechanism to facilitate and assist Nigeria meet its Nationally Determined Contribution target and low carbon pathway for socio-economic development in line with the Economic Recovery Growth Plan (ERGP).
- (xii) Development of Sectoral Action Plan for Nationally Determined Contribution (NDC) implementation road map.
- (xiii) Other programs/efforts are as follows:
  - (a) Energizing Education Program (EEP) for seven universities in Ebonyi, Delta, Anambra, Sokoto, Kano, Benue, and Bauchi states at the cost of N8,553,600,827.75 for 12.5 MW (off grid).
  - (b) Afforestation programs in Borno, Bauchi, Gombe, Jigawa, Kastina, Adamawa, Kano, Oyo, Plateau, Zamfara, Kaduna, Niger, Oyo, Ondo, Ogun, Abia, and Edo States for N1, 990,331,366.00 covering 1178 Ha.
  - (c) Renewable Energy Micro Utility (REMU) at Sokoto for N146, 067,806.25 for 60KW (grid connected).



- (d) National Trader Moni program under which low income business people are given interest free sum of ten thousand (to inject into their businesses) repayable over a specified period.
  - (e) Establishment of Climate Change Desk Officers across the states of the federation.
  - (f) Commencement of the implementation of the NDC with the support of UNDP.
  - (g) Capacity Building on Measurement, Reporting and Verification (MRV) and GHG Inventory achieved on sector mapping.
- (xiv) Nigeria has a number of bilateral and multilateral agreement cooperation with World Bank, Global Environment Fund (GEF) Green Climate Fund (GCF), etc.

In striving to address poverty, it is important to note that significant portions of Nigeria's population and economy are tied to activities that are climate sensitive, such as rain-fed agriculture, livestock rearing, fisheries, and forest products extraction. The heavily populated coastal areas and Northern Sahel zone are particularly vulnerable to climate change. As part of efforts to address this vulnerability, Nigeria, in June 2014, in Equatorial Guinea, together with the Heads of State and Government of the African Union put agriculture on top of Africa's agenda when they adopted the Malabo Declaration on Accelerated Agricultural Growth and Transformation for Shared Prosperity and Improved Livelihoods (Malabo Declaration 2014). In the Declaration, African leaders made several commitments, among them, to end hunger in Africa by 2025.

The discussions above reveal that Nigeria has been making domestic and international efforts at adaptation mechanism and to attain SDGs targets. She has also keyed into bilateral, multinational, and regional initiatives. Although there are policy framework arrangements to manage climate change in Nigeria, in reality, the policies are not harmonized and remain mostly on paper. This is because the legal framework specific to climate change is non-existent and therefore not legally binding. Efforts to manage climate change therefore remain ad hoc and superficial. This is due mainly to the fact that Nigeria has failed to establish a robust climate change law that should incorporate some of the global initiatives and best practices enumerated earlier. This leads us to the need to x-ray the legal issues, challenges, and strategies in the application of climate change adaptation mechanism.

## **Legal Issues, Challenges, and Strategies in the Application of Climate Change Adaptation Mechanism**

There are many legal issues and challenges which hamper the application of climate change adaptation mechanisms in Nigeria. These are examined in this section with a view to proffering strategies to overcome them.

- (i) **Lack of legal framework:** In Nigeria, there is the National Adaptation Strategy and Plan of Action on Climate Change for Nigeria (NASPA-CCN) and the

Nigeria Climate Change Policy Response and Strategy (NCCPRS). Nevertheless, despite the well acknowledged position that there is a close nexus between poverty (SDG 1) and climate change adaptation mechanism as earlier articulated in this chapter, Nigeria still lacks the legally binding law on the subject matter. It has been argued at different fora that the non-transmission of the policies into Nigerian laws is in breach of the climate change policy thrust. This is a challenge and one which makes it difficult to assess the effectiveness of such policies. It has however been suggested in some quarters that the birth of Nigeria's Intended Nationally Determined Contribution (INDC) will compel Nigeria to expedite action on establishing relevant laws and become more focused in terms of combating the impact of climate change. Unfortunately, the provisions of the INDC do not appear to have reflected this expectation.

Furthermore, apart from the absence of a law on climate change to galvanize action toward effective policy implementation, there is equally no existing law in Nigeria that provides for climate change management. In fact, until very recently actions taken by the Ministry of Environment Department of Climate Change have been largely ad hoc and divorced from a bigger picture of global fight against climate change. This is due largely to the absence of a climate change law that will regulate the management of every impact of climate change. The challenge is that without a binding climate change law, it will be difficult to achieve effective adaptation mechanism to reduce poverty in line with the SDGs. In terms of strategy to overcome this challenge, therefore, there is the need to establish a legal framework that would comprehensively and legally bind the various policies on adaptation mechanism. This, for example, is the case in Bangladesh which is a good example of the impact a climate change law can have in the struggle to achieve SDG1.

- (ii) **Lack of equality:** It has been argued in some quarters that calls to eradicate poverty are meaningless without commensurate and committed policy action to reduce inequality. This is a global menace that must be conquered to stand a good chance of meeting the SDG 1 target. For instance, the income of the poorest 20% of the world's population has only moved from USD \$0.94 in 1990 to \$1.90 today, but that of the rest of the population has grown from an average USD \$12.85 to \$18.63 over the same period, thus creating great inequality. This inequality is projected to worsen with an income gap of USD \$18.79 by 2030 which is almost double what it was in 1990 (Hope 2018). A recent report by the research organization, Development Initiatives, which looked at the period between 2010 and 2017, found that notwithstanding global commitments to zero poverty as per SDG 1, the attitude of the global actors is at variance with the espoused commitment. Aid donors promised in 1970 to give 0.7% of their GNI to fighting poverty, and yet the average spent up till 2017 is about 0.31%, and this is lower than it was then (0.33%) (Ibid).

In Africa where the population is expanding at a rate of more than 2% per year, a combination of double digit GDP growth and dramatic declines in inequality is a sine qua non for plummeting the level of extreme poverty to below 5% by 2030 and much more than would be expected to bring the level of poverty to 0% by 2030. Corroborating this view, the UN estimates that without

significant changes in behavior, more than 7% of the global population may remain in poverty by the year 2030, including about 30% of the populations in Africa and the least developed countries (LDCs). The challenge is for the governments, including the Nigerian government, to bridge this poverty gap.

Since equality is a sine qua non to the attainment of SDG 1, a major strategy should therefore be to ensure that equality is an inclusive part of the fight to eradicate poverty. It is vital that any form of mainstreaming incorporates a poverty focus rather than viewing it as a purely environmental problem. This will ensure that aid initiatives address the vulnerability of the poor to climate changes and equally to align such aids with the priorities of the SDGs. Development partners must continue to support efforts to bridge the poverty gap and to eradicate poverty. In 2010, the International Development Association (IDA) gave almost USD \$2 billion more in loans to middle-income countries (MICs) than to the LDCs, whereas in 2017, it gave over USD \$2 billion more in loans to LDCs than to MICs (Dodd et al. 2019). A research also found that if actors met their commitments, an extra USD \$1.5tn would be available between 2017 and 2030 to help lift the very poorest in the world out of poverty. A number of both bilateral and multilateral donors are driving these trends.

While there is no one-size-fits-all policy prescription that guarantees delivery of a more equal and prosperous society, one overarching message resonates. It is that calls to exterminate poverty are meaningless without concerted and committed policy action for dramatic decrease in inequalities (Zhenmin 2019), in income, in opportunity, in exposure to risk across gender, within countries and between countries. No doubt, well-designed fiscal policies can help smooth the business cycle, provide public goods, enact reforms that would help build resilience, correct market failures which include, for example, raising potential economic growth and its inclusiveness, and directly influencing the income distribution to bridge inequality. Specifically, Nigeria could introduce measures to bring all the poor under coverage of social protection system and anti-poverty strategy of the government through, for example, an expanded Social Safety Net Programmes (SSNP) to address risk and vulnerability as a means of reducing poverty and inequality.

- (iii) **Inadequate political willpower:** This entails the lack of sufficient political willpower of government to ensure SDG 1 succeeds, and the inability to elevate SDGs to a very high political level to be able to give it the national attention and priority that climate change issues deserve. Presently, Nigeria does not even have a climate change law to give focus to the fight against climate change. Meanwhile, the political will of the government as good leadership and governance are crucial for implementation of adaptation mechanism. Akin to this is the fact that Nigeria has also not created the favorable climate environment for addressing its long-standing armed conflict or civil unrest, kidnapping, and political instability. This means that decent jobs for most citizens will become increasingly out of reach resulting in weak economic performance. The required strategy to address the problem is for the government to muster

enough political courage to elevate critical decision-making for climate change matters to the presidency for needed priority and implementation directives.

- (iv) **Centralization of information and services on climate change:** The issue of centralization of information and services at the Ministry of Environment and several other ministries without decentralizing to the door steps of the citizens remains a challenge. This is because adaptation is likely to be successful if people are informed about climate change, how it affects them, and options for doing something about it. Successful climate change interventions are dependent on high-quality accessible information to allow effective decision-making. As the impacts of climate change are difficult to predict accurately, adaptation activities need to be flexible and responsive to new information, and robust enough to withstand a wide range of plausible futures.

There are many examples of use of information to enhance adaptation mechanism. For instance, the use of risk management and coping thresholds is an area of applied adaptation research of growing importance ([Part 2: Adaptation](#)). In addition, agricultural climate information is now used to advise farmers about their choice of crops and methods of cultivation, which in turn has provided major benefits in terms of increased yields and preventing food shortages. Similarly, better information and early warning systems for farmers can reduce vulnerability to inter-annual climate variations and enable responses to be proactive rather than reactive. Climate information can generate substantial benefits in other areas as well, including water management, planning and delivery of health services, and improved warning for extreme weather events. The challenge for Nigeria is that in spite of what is provided for in its Nationally Determined Contribution (NDC), Nigeria has failed to decentralize the delivery of public services and take them to the doorsteps of millions of underserved citizens. It has also not actively leveraged the local knowledge of the communities. For example, in Arochukwu, in the Eastern part of Nigeria, farmers can predict a bountiful harvest merely by observing how severe the harmattan is. This highlights the importance of capturing local knowledge, reviewing and assessing its applicability, and its dissemination among other communities and relevant agencies. The strategy to overcome this challenge is to decentralize information. As the poor already have a lot of knowledge about how to cope with climate variability, adaptation activities should take account of this knowledge, where benefits are proven. Incorporating local knowledge into policy actions could help the governments of Nigeria to accommodate specific needs of poor people and ensure that strategies are taken up by local communities. Thus, relevant information must be decentralized from top to the local levels as a matter of deliberate policy.

- (v) **Weak human and institutional capacity:** In Nigeria there is weak human and institutional capacity for climate change related issues. This is because climate change is fast altering the landscapes, and the inability of the various government institutions and weak human capacity to respond appropriately has created various risks due to shortages of resources such as land (Orie 2015) and water, with attendant negative secondary impacts, hunger, poverty,

sickness, loss of employment, etc. The poor responses have in turn opened the door to conflict. This alteration comes mainly from the arid north; Nigeria's northern Sahel area (the transition zone between the Sahara desert to the north and the grasslands to the south) gets less than 10 inches of rainfall a year already, a full 25% less than 30 years ago; areas of southern Nigeria where recorded volumes of torrential rains increased 20% across various southern states, some of which already see up to 160 inches of rainfall a year, with wet seasons lasting 8–10 months (Odjugo 2005), and along the southern coastline, where sea levels could rise 1.5–3 feet by century's end which is a further increase over the nearly 1-foot rise observed in the last 50 years (Federal Ministry of Environment 2009). (Federal Ministry of Environment, Nigeria and Climate Change: Road to Cop15 (Abuja, Federal Ministry of Environment 2009).) In fact, in 2012 about 26 out of 36 states in Nigeria were submerged in flood water. The situation is getting worse due to inadequate experts and institutions to properly contend with the developments. In Nigeria, there is no conscious effort either toward manpower or institutional development. Most discussions on the impacts of climate change end at the federal level, occasionally at state level but never at the local government level. The implication of this is that there is disconnect between what happens at the federal and state levels and that of the local government. The result is that at the local level people are not motivated to share in the national vision. For example, the locals still engage in illegal sand mining resulting in erosion, land-slides, and other negative impacts on the ecosystem, while at the federal level government is fighting erosion and landslides.

The strategy to checkmate this challenge is to improve human and institutional capacity development at the grassroot level such that a culture of comprehensive risk reduction management would naturally evolve overtime as the locals become stakeholders and team players with the government. Government and private actors also need to ensure that particular adaptive responses do not themselves fuel violence but actively help build peace. Successful adaptation measures will be crosscutting in design and impact, based on inclusive planning and implementation and steer clear of political patronage traps. An example is the system of Payment for Ecological Services (PES) (Fagbohun and Orie 2015).

- (vi) **Inadequate needs assessment and financing strategy:** This is a challenge that cuts across the various adaptation mechanisms. It is so because adaptation as a mechanism is not cheap and therefore requires a lot of funding which most of the developing countries like Nigeria do not have. For instance, for the adaptation mechanism to play its role in achieving SDG1, there must be technology transfer from the developed countries to the developing countries, and also data have to be purchased. In the last couple of years, China has been championing transfer of technology through South-South Cooperation. So many member countries of the South-South Cooperation like Bangladesh, Kenya, Ethiopia, South Africa, Angola, etc. have benefitted richly from this collaboration compared to Nigeria. Some of the identified areas are water resources, agriculture,

tourism and health, etc. Nigeria should reposition itself to aggressively acquire the much needed technology to adapt to climate change scenarios. No doubt, recent years have seen evidence of China's technical assistance to Nigeria. The argument here is that such assistance would have been much more both in volume and quality had Nigeria been more proactive like some other member countries like Bangladesh and Kenya where CC is elevated to a political level.

In addition, Nigeria is also expected to have done its needs assessment and financing strategy which should be in tandem with its SDG 1. Such an assessment will ensure that aids initiatives address the vulnerability of the poor to climate changes and equally to align such aids with the priorities of achieving SDGs 1. However, the overriding challenge is that without a strong legal framework on climate change, the international community may not be willing to provide substantial aids. Thus, the strategy to overcome this challenge is to do adequate needs assessment and financial strategy, as well as have a CC law in place in order to attract the international community to support Nigeria fully in its adaptation mechanism to attain SDG 1.

## **Conclusion and Recommendation**

In response to achieving the global target of SDG 1 by employing adaptation mechanisms, this chapter examined the legal angle to Nigeria's efforts at combating poverty. This was predicated on World Poverty Clock data that by 2018, Nigeria had the largest extreme poverty population of 86.9 million implying that the people are vulnerable to malnutrition, armed conflict, migration, and other socioeconomic and environmental shocks. It was argued that unfortunately for Nigeria, her adaptation efforts are inadequate to ensure the eradication of poverty by 2030. Consequently, Nigeria needs a comprehensive legal framework which is in line with global best practices to enhance her chances of attaining the objective of SDG 1.

The chapter also established the nexus between climate change adaptation mechanism and poverty reduction, showing a direct positive relationship, such that as climate change-induced poverty occurs, the adaptation measures alleviate the adverse consequences and thus make the attainment of SDG 1 feasible. Conversely, weak adaptation mechanism cannot effectively combat the impacts of climate change and invariably undermines the attainment of SDG 1.

It was shown that although there is a policy framework arrangement to manage climate change in Nigeria, in reality, the policies are not harmonized and remain mostly on paper. This is because the legal framework specific to climate change is non-existent and the various related policies are not legally binding. Efforts to manage climate change remain ad hoc and superficial. Therefore, a way forward was proffered based on some global best practices which Nigeria could leverage in the implementation of adaptation laws.

The legal issues and challenges militating against Nigeria's efforts at effectively employing adaptation mechanisms were discussed. They include lack of legal framework, inequality, inadequate political will, and centralization of information

and services. Others are weak human and institutional capacities and lack of needs assessment and financing strategy regarding adaptation mechanism. These challenges were matched with corresponding and relevant strategies which include establishment of a robust climate change law which ought to draw from global best practices and incorporate the extant regulations and policies, curbing inequality through the introduction of social protection system and anti-poverty strategy for the poor to address risk and vulnerability. In addition, the law must provide for climate change and related issues to be elevated to a political level such that government shall muster the necessary political will to domicile climate change related issues at the presidency and give top priority to such issues. Other strategies are decentralization of information down to citizens at the local government level, human and institutional capacity building, and undertaking of needs assessment and financing strategy. The chapter therefore makes the following recommendations.

The chapter thus recommends the establishment of climate change law in Nigeria that incorporates adaptation measures and mainstreaming of climate change issues towards the attainment of SDG 1. This law should be comprehensive enough to give legal backing to the various extant policies. It should cover social protection system and anti-poverty strategy for the poor to address risk and vulnerability; elevation of critical climate change decision-making to the presidency in order to get priority attention and the needed funding; as well as decentralization of information down to citizens at the local government level. Provisions should also be made for periodic training of staff and reform of institutions to effectively undertake climate change and adaptation projects. Significantly, needs assessment and financing strategy should be undertaken to the standards required by development partners and aid givers to attract the necessary levels of foreign funds and maintain transparency and accountability. These recommendations constitute the legal imperatives to properly regulate institutional and policy interventions to impacts of climate change and if implemented will guarantee attainment of SDG 1 by 2030 and thereby enhance poverty reduction in Nigeria.

---

## References

- Addis Ababa Action Agenda – the United Nations (2005). Available <https://www.un.org/esa/ffd/ffd3/press.../countries-reach-historic-agreement.html>
- Addis Ababa Action Agenda of the Third International Conference on Financing for Development (Addis Ababa Action Agenda) 2015 (endorsed by the General Assembly in its resolution 69/313 of 27 July 2015). Available <https://www.un.org/esa/ffd/ffd3/press%E2%80%A6/countries-reach-historic-agreement.html>
- Atkinson AB (2016) Monitoring global poverty. Report of the commission on global poverty. World Bank Group, Washington, DC. Available <https://openknowledge.worldbank.org/>
- Ban Ki-Moon United Nations Millennium Development Goals – the United Nations. Available <https://www.un.org/millenniumgoals/>
- Bankoff G (1999) A history of poverty: the politics of natural disasters in the Philippines, 1985–1995. *Pac Rev* 12(3):8–12
- Chen S, Ravallion M (2010) The developing world is poorer than we thought, but no less successful in the fight against poverty. *Q J Econ* 125(4):1577–1625

- CIDA (2001) Canada climate change development fund management framework and business plan. Available [cida.gc.ca/cida\\_ind.nsf/c868c8f732a05e34852565a20067581f/f5036f5adbab9c3385256ad10073ea48?OpenDocument](http://cida.gc.ca/cida_ind.nsf/c868c8f732a05e34852565a20067581f/f5036f5adbab9c3385256ad10073ea48?OpenDocument)
- Climate change is a threat – and an opportunity... (2016) World Bank Group. Available [www.worldbank.org/.../climate-change-is-a-threat%2D%2D-and-an-opportunity%2D%2D-for-the-pri...](http://www.worldbank.org/.../climate-change-is-a-threat%2D%2D-and-an-opportunity%2D%2D-for-the-pri...)
- DFID (2000) Achieving sustainability: poverty elimination and the environment. Available [www.albarcharia.ma/.../1575Target\\_Strategy\\_Paper\\_Achieving\\_sustainability\\_pover...](http://www.albarcharia.ma/.../1575Target_Strategy_Paper_Achieving_sustainability_pover...)
- DFID, EC, UNDP, World Bank (2002) Linking poverty reduction and environmental management: policy challenges and opportunities, consultation draft of discussion document. DFID, EC, UNDP, World Bank, London/Brussels/New York/Washington. Available [documents.worldbank.org/curated/en/347841468766173173/pdf/multi0page.pdf](http://documents.worldbank.org/curated/en/347841468766173173/pdf/multi0page.pdf)
- Dodd et al (2019) Six ways to refocus ODA to end poverty and meet the SDGs. Available [devinit.org/post/refocus-oda-end-poverty-meet-sdgs/](http://devinit.org/post/refocus-oda-end-poverty-meet-sdgs/)
- Ending Extreme Poverty and Promoting Shared Prosperity (2013) World bank News. Available [www.worldbank.org/news/feature,2013/04/17](http://www.worldbank.org/news/feature,2013/04/17)
- European consensus on development | International (2017) European Commission- Fact Sheet. Available [ec.europa.eu/international-partnerships/european-co](http://ec.europa.eu/international-partnerships/european-co)
- Fagbohun OA, Orié EG (2015) Nigeria: *law and policy issues in climate change*, ELRI, monograph series. Available [https://kdp.amazon.com/en\\_US/bookshelf?language=en\\_US](https://kdp.amazon.com/en_US/bookshelf?language=en_US)
- Federal Ministry of Environment (2009) Nigeria and climate change: road to Cop15 Abuja Federal Ministry of Environment
- Fiszbein A, Schady N (2009) Conditional cash transfers. World Bank policy research report. Available <http://siteresources.worldbank.org/intcct/resources/5757608-1234228266004/prcct-web-noembargo.pdf>
- Global climate change: vital signs of the planet|precipitation... Available <https://pmm.nasa.gov/education/websites/global-climate-change-vital-signs-planet>
- Gomez-Echeverri L (2018) Climate and development: enhancing impact through stronger linkages in the implementation of the Paris agreement and the Sustainable Development Goals (SDGs). *Phil Trans R Soc A* 376(2119):20160444. <https://doi.org/10.1098/rsta.2016.0444>
- Gurtner B (2010) The financial and economic crisis and developing countries. Available <https://journals.openedition.org/poldev/144>
- Hope A (2018) Launch: investments to end poverty 2018 – development initiatives. Available [devinit.org/post/launch-investments-to-end-poverty-2018/](http://devinit.org/post/launch-investments-to-end-poverty-2018/)
- IPCC (1995) Climate change: intergovernmental panel on climate change. Cambridge University Press, Cambridge. Available <https://ipcc.ch/ipccreports/tar/wg1/index.php?idp=47>
- IPCC 2001 – IPCC. Available <https://www.ipcc.ch/2001/>
- IPCC report 2014 fifth assessment report – IPCC. Available <https://www.ipcc.ch/assessment-report/ar5/B>
- Kelman (2017) Linking disaster risk reduction, climate change, and the sustainable development goals. *Disaster Prev Manag: Int J* 26(3):254–258. <https://doi.org/10.1108/DPM-02-2017-0043>
- Lipper L et al (2014) Climate-smart agriculture for food security. *Nat Clim Change* 4(12):1068–1072
- Malabo declaration on accelerated agricultural growth and transformation for shared prosperity and improved livelihoods (2014). Available [https://www.resakss.org/sites/default/files/Malabo%20Declaration%20on%20Agriculture\\_2014\\_11%2026-.pdf](https://www.resakss.org/sites/default/files/Malabo%20Declaration%20on%20Agriculture_2014_11%2026-.pdf)
- McGuigan C et al (2002) Poverty and climate change: assessing impacts in developing countries and the initiatives of the international community. Available <https://www.odi.org/sites/odi.org.uk/files/odi-assets/publications-opinion-files/3449.pdf>
- Medugu NI et al (2011) Drought and desertification management in arid and semi-arid zones of Northern Nigeria'. *Emerald Manag Environ Q* 22(5):610. Available [www.fao.org/3/a-ad710e.pdf](http://www.fao.org/3/a-ad710e.pdf). 2003
- Messer NM (2003) The role of local institutions and their interaction in disaster risk... Available [www.fao.org](http://www.fao.org)



- National adaptation strategy and plan of action on climate... – CSDevNet [csdevnet.org/.../NATIONAL-ADAPTATION-STRATEGY-AND-PLAN-OF-ACTION...](http://csdevnet.org/.../NATIONAL-ADAPTATION-STRATEGY-AND-PLAN-OF-ACTION...)
- Odjugo PAO (2005) An analysis of rainfall pattern in Nigeria (2005). *Global J Environ Sci* 4(2):139–145
- Olabode PO et al (2015) Determinants of poverty level in Nigeria. *J Sustain Dev* 8:1
- Olawale S (2018) Nigeria poverty statistics and poverty rate in Nigeria – NaijaQuest.Com. Available <https://naijaquest.com/nigeria-poverty-statistics/>. 5 Feb 2018
- Olofin, Adejumo & Sanusi (2015) Determinants of Poverty Level in Nigeria. *Journal of Sustainable Development* 8(1):235–241. Available <https://doi.org/10.5539/jsd.v8n1p235>
- Olsthoorn et al (1999) The Netherlands, always vulnerable to floods, has a new approach to... Available <https://www.pri.org/.../netherlands-always-vulnerable-floods-has-new-approach-water...>
- Orie EG (2015) Climate change and sustainable development: the Nigerian legal experience. *NOUN Curr Issues Nigerian Law* 5:68–114
- Orie EG (2017) Legal perspective to the mitigation of impact of climate change in Nigeria. *Univ Jos Law J* 12(1):323–344
- Parnell S (2017) Africa's urban risk and resilience. *Int J Disaster Risk Reduct* 26:1–6
- Part 2: Adaptation lessons from past experience – OECD.org. Available <https://www.oecd.org/env/cc/4494574.pdf>
- Portugal Sustainable Development Knowledge Platform (2016). Available <https://sustainabledevelopment.un.org/memberstates/portugal>
- Poverty and Climate Change – odi.org. Available <https://www.odi.org/resources/docs/3449.pdf>
- Poverty|United Nations Educational, Scientific and Cultural... Available [www.unesco.org/new/en/social-and-human-sciences/.../international.../poverty/](http://www.unesco.org/new/en/social-and-human-sciences/.../international.../poverty/)
- Report of the conference of parties on its seventh session held at Marrakesh from 29th October to 10th November 2001: part II – action taken by the conference of parties. Available <https://unfccc.int/node/2516>
- Roser M, Ortiz-Ospina E (2019) Global extreme poverty – our world in data. Available <https://ourworldindata.org/extreme-poverty>
- Sayne A (2011) Climate change adaptation and conflict in Nigeria, United States Institute of Peace Special Report. Available <http://www.usip.org/sites/default/files/Climate>
- Smucker TA et al (2015) Differentiated livelihoods, local institutions, and the adaptation imperative: assessing climate change adaptation policy in Tanzania. *Geoforum* 59:39–50
- Standing Orders on Disaster (2010) – PreventionWeb. Available [https://www.preventionweb.net/files/18240\\_sodapprovedbyndmb.pdf](https://www.preventionweb.net/files/18240_sodapprovedbyndmb.pdf)
- Sustainable Development, Poverty Eradication and Reducing... – IPCC. Available [https://report.ipcc.ch/sr15/pdf/sr15\\_chapter5.pdf](https://report.ipcc.ch/sr15/pdf/sr15_chapter5.pdf)
- The global extreme poverty- our world in data. Available <https://ourworldindata.org/happiness-and-life-satisfaction/>
- The Sustainable Development Goals Report 2018|Multimedia Library... Available <https://www.un.org/development/.../publications/the-sustainable-development-goals-re...>
- The World Bank research report (2015) A measured approach to ending poverty and boosting shared prosperity: concepts, data, and the twin goals. World Bank, Washington, DC, pp 37, 38
- United Nations Framework Convention on Climate Change. Available <http://environment-ecology.com/climate-change.html>
- Weisser F (2014) Translating the adaptation to climate change paradigm: the politics of a travelling idea in Africa. *Geogr J* 180(2):111–119
- World Bank (1990) *World development report, poverty*. Oxford University Press, New York
- Zhenmin L (2019) Ending poverty is possible, but it means facing up to inequality – within & between countries INTER PRESS SERVICE. Available <http://www.ipsnew>

**Open Access** This chapter is licensed under the terms of the Creative Commons Attribution 4.0 International License (<http://creativecommons.org/licenses/by/4.0/>), which permits use, sharing, adaptation, distribution and reproduction in any medium or format, as long as you give appropriate credit to the original author(s) and the source, provide a link to the Creative Commons license and indicate if changes were made.

The images or other third party material in this chapter are included in the chapter's Creative Commons license, unless indicated otherwise in a credit line to the material. If material is not included in the chapter's Creative Commons license and your intended use is not permitted by statutory regulation or exceeds the permitted use, you will need to obtain permission directly from the copyright holder.





# Climate Variability on Fishing Activities in Inland Waters: Case of Owena River in Ondo and Osun States, Nigeria

# 94

Lydia Adeleke, Jacob Victor Jerry, Desalegn Ayal, Akinola Joshua Oluwatobi, Ayodele Idowu Sunday, and Ajibefun Igbekele Amos

## Contents

Introduction .....	1920
The Chapter Design .....	1922
Chapter Design .....	1923
Cronbach Alpha .....	1924
Distribution According to Gender and Age Group of Respondent in Owena Osun and Ondo States .....	1925
Secondary Occupation and Monthly Income of Respondent in Owena Osun and Ondo State .....	1925
Effect of Climate Variability on Fish Catch in Owena Ondo and Osun States .....	1927

This chapter was previously published non-open access with exclusive rights reserved by the Publisher. It has been changed retrospectively to open access under a CC BY 4.0 license and the copyright holder is “The Author(s)”. For further details, please see the license information at the end of the chapter.

L. Adeleke (✉)

Department of Fisheries and Aquaculture Technology, Federal University of Technology, Akure, Nigeria

e-mail: [mladeleke@futa.edu.ng](mailto:mladeleke@futa.edu.ng)

J. V. Jerry · A. J. Oluwatobi · A. I. Sunday

Department of Fisheries and Aquaculture Technology, Federal University of Technology, Akure (FUTA), Akure, Nigeria

e-mail: [jacobvictor402@yahoo.com](mailto:jacobvictor402@yahoo.com); [joesheathakinola@gmail.com](mailto:joesheathakinola@gmail.com); [ayodeleidowusunday@gmail.com](mailto:ayodeleidowusunday@gmail.com)

D. Ayal

Center for Food Security Studies, College of Development Studies, Addis Ababa University, Addis Ababa, Ethiopia

e-mail: [desalegn.yayeh@aau.edu.et](mailto:desalegn.yayeh@aau.edu.et)

A. I. Amos

Department of Agricultural and Resource Economics, Federal University of Technology, Akure (FUTA), Akure, Nigeria

e-mail: [iaajibefun@futa.edu.ng](mailto:iaajibefun@futa.edu.ng)

© The Author(s) 2021

W. Leal Filho et al. (eds.), *African Handbook of Climate Change Adaptation*, [https://doi.org/10.1007/978-3-030-45106-6\\_91](https://doi.org/10.1007/978-3-030-45106-6_91)

1919

Likely Effect of Climate Variability on Fisher Folks in Owena Ondo and Osun States .....	1929
Effect of Climate Variability on Fishing Techniques in Owena Ondo and Osun States .....	1931
Effect of Variability in Climate on Choice of Fishing Equipment in Owena Ondo and Osun States .....	1932
Climatic Trends in Owena River Between 2008 and 2017: Wind Trends and Rainfall Pattern in Owena Osun State Between 2008 and 2017 .....	1933
Conclusion .....	1935
References .....	1935

---

## Abstract

This chapter examined the effects of climate variability on fishing activities in inland waters: the case of Owena River in Ondo and Osun States, Nigeria. The particular inland water body (Owena) was selected purposively because the Owena River crosses across the two States (Ondo and Osun States). A total of 100 respondents/fisher folks were selected randomly. Primary data was used to get information from the respondents with the aid of the structured questionnaire. Secondary data was used to get information on the climate variability existing in the locations in order to achieve the set objectives. Specifically, the effects of climatic variables such as temperature, rainfall, and wind were determined on fisher folk, fishing duration, fish catch, fishing techniques, and fishing equipment/gears. Descriptive survey design was used to examine the demographic characteristics of respondents. The result revealed that most of the respondents (96%) were male. This chapter established that climate variability particularly strong wind, rainfall, and temperature has adverse effects on fishing activities such as reduction in fish catch, long duration of fishing, loss of fishing gear, change in fishing techniques, and effect on health; hence, the livelihoods of the residence are adversely affected on the long run. In addition to the adverse effect of poverty and loss of life for the fisher folks. Although, the fisher folks livelihoods depend mainly on fisheries resources and optimum fishing depends on favorable climate/weather conditions. Therefore, proper preventive coping strategies against the adverse effect of climate variables should be paramount in both States (Ondo and Ekiti) to improve livelihoods and food security.

---

## Keywords

Climate variability · Fishing activities · Inland waters · Livelihoods · Nigeria

---

## Introduction

Climate variability is the observable change in atmospheric conditions of a given area at a particular time usually 10 years. The Intergovernmental Panel on Climate Change defined climate change or variability as any change in climate overtime, whether due to natural variability or as a result of human activities. Temperature and precipitation are the most common climate variables critical to measure with regard to food systems. Climate variability poses a threat to the effective productivity and sustainability of fishing activities and resources around the world. Climate

variabilities are changes or variation in climate condition due to factors such as anthropogenic factors, e.g., bush burning, release of fossil fuel, and other biochemical activities which will consequently lead to global warming, loss of abundant fisheries resources and other agricultural resources, and also depletion of ozone layer (Cheung et al. 2009).

Climate plays an important role in the world. Because most livelihood and living resources depend on suitable climatic condition for survival and continuity, its effects can be felt directly or indirectly. The Intergovernmental Panel on Climate Change (IPCC) predicted that during the next decades, billions of people, especially those in developing countries, will face changes in rainfall patterns that will contribute to severe water shortages or flooding, rising temperatures that will cause shifts in crop growing season, and aquatic organism distribution.

Climate change and global warming will definitely cause adverse effects on the livelihoods of the populace in Nigeria if not prevented, and it will affect crop production, livestock production, fisheries, forestry, and post-harvest activities, because the rainfall regimes and patterns will be altered, floods which devastate farmlands would occur, increase in temperature and humidity which increases pest and disease would occur, and other natural disasters like floods, ocean, and storm surges, which not only damage Nigerians' livelihood but also cause harm to life and property, would occur.

Nigeria is a West African country found in the tropics; it has only two seasons which are the dry season and the raining season. The country is one of the most populated countries in the world with over 180 million people and is blessed with abundant aquatic resources. However, Nigeria is vulnerable to climate change impacts due to its geography, location, climate, vegetation, soils, economic structure, population and settlement, energy demands, and agricultural activities.

The prominence and persistence of climate change has made it a global menace with adverse effects borne by developing nations (Agbebi and Omoniyi 2011). Global disasters perpetrated by storm-surge, flood, coastal erosion, and other natural hazards have brought much anxiety and bewilderment to the world governing agencies. These impacts and implications are profound as they occur through the increasing changes in water temperature/sea levels (Adeleke and Omoboyeje 2016).

Fisheries is one of the fastest growing sectors in the world, and it provides employment, food, income, and recreation for many people globally. The dependence of the human populace on fishing activities as a major source of food and livelihood is linked to the rich nutritional composition of fisheries products (fish, crayfish, prawn, shrimps, etc.), palatability, digestibility, and high source of animal protein, omega fatty acid, and vitamins.

Despite these numerous and enviable benefits, fisheries resources, functions, and structures have come under intense threat due to the extensive and increasing anthropogenic activities that exist in and around various water bodies. These result in a wide array of problems for both the aquatic resources users and decision makers. These anthropogenic activities often lead to induced climate change which have shown to have apparent effect on aquatic ecosystems, the economic and social system that depends on them (World Fish Centre 2006; Perry et al. 2009).

Recent studies on the effect of climate change on aquaculture production and management in Akure metropolis, Ondo State, and also the occurrences of climate change and its effect on the fishing activities in the coastal region of Ondo State (Adeleke and Omoboyeje 2016; Adeleke and Balogun 2013), respectively, have revealed the occurrences of climate variability and its effect on fishing activities through alteration in temperature, wind pattern, rainfall pattern, water qualities, and availability.

Severe effects such as great reduction in aquatic resources, low fish catch, reduced fish production, slow growth rate, increase in boat mishap, loss of lives, poverty, etc. arise mainly from increased flooding, variation in rainfall pattern and intensity, and rising temperature. Idowu et al. (2011) reported that the impacts of climate change are expected to exacerbate the impacts of human pressure which will further diminish the ability of natural ecosystems to continue to provide ecosystem services and may cause invasion of strange species that are favored by climate change thereby threatening biodiversity. Also, poor adaptation strategies and high dependence on fisheries have been reported to expose small-scale fisher folks in most developing country to climate change (Allison et al. 2009). These effects impact on fish species composition, production, and yield, risk of health and life of fisher folk, and loss and damage to livelihood assets. Therefore, the fisher folk will have to seek adaptation and mitigation strategies in order to sustain their livelihood.

The inhabitants of Ondo and Osun are mostly small-scale commercial fish farmers that depend on fisheries resources as a source of food and livelihood. However, climate variability may threaten their livelihood and infrastructural development. Hence, there is the need to identify the pathways through which climate variability and change are impacting or likely to impact the fishing-dependent communities. This will also help policy makers in implementing adaptive strategies to be able to withstand and cope with these adverse climate variability. This research work will examine the effect of climate variability on fishing activities in Owena Ondo and Osun States.

The following research questions were answered in this chapter. What are the effects in Owena, Nigeria, are of temperature, rainfall, and wind variability on fish catch; rainfall, temperature, and wind variability on fishing techniques and equipment; rainfall, temperature, and wind variability on fishing duration; and rainfall, temperature, and wind variability on fisher folks.

---

## The Chapter Design

The chapter design that is adopted in this chapter is descriptive survey designed to obtain precise information on the current status of climate change and to possibly draw a valid conclusion from the survey. It should be noted that there are no climate change nor meteorological records in the area as observed limitation of the chapter.

Owena Ondo State and Owena Osun State were used. Owena Ondo is located at geographical coordinate 7° 12' 0" North, 5° 1' 0" East, while Owena Osun is located at latitude 7.19908 and longitude 5.018267 degree. Both areas were purposively



**Fig. 1** Map of Nigeria. (Source: Authors’ Download: Google map, 2018)

selected based on general fishing activities, trading, accessibility, and anthropogenic activities (Figs. 1 and 2).

## Chapter Design

A multistage sampling technique was used to select the samples in this chapter. The first stage involved the purposive selection of Owena Ijesa Ori Ade Osun State and Owena Market road Ondo East Local Government and Owena Ondo State. The justification of the selection is based on the fact that the two locations are close and prominent for fishing activities and have the same water body flow to both locations. The target population are fisher folk, and fishermen in Owena Ondo State and Owena Osun State were purposively selected based on their closeness of the site and the prominent fishing activities in the area. Primary data from fisher folks were collected with the aid of an interview schedule using structured questionnaire. 50 questionnaires each were administered to both locations making it 100 in total. The interview schedules were divided into sections based on the objectives of the research. Data obtained from various sources were processed before analysis. The data were edited, coded, and entered for analysis in the Statistical Package for Social Sciences (SPSS). Summary tables were then prepared to facilitate recording and further analysis. Data obtained through questionnaire were analyzed using quantitative methods. The data



**Fig. 2** Map of study area. (Source: Authors’ Download: Google map, 2018)

from the questionnaire were subjected to computation of simple statistics such as frequencies, percentages, tabulations, and cross-tabulations and presented in form of tables, graphs, and charts.

A multistage sampling technique was used to select the samples in this chapter. The first stage involved the purposive selection of Owena Ijesa Ori Ade Osun State and Owena Market road Ondo East local Government.

### Cronbach Alpha

Cronbach alpha ( $\alpha$ ) was used to analyze the sufficiency of the survey instrument.

$$\text{Cronbach } \alpha = \frac{N - \bar{C}}{\bar{V} + (N - 1) \cdot \bar{C}}$$

Where:

$N$  = No of items (12)

$\bar{C}$  = Average inter – item covariance among the items

$\bar{V}$  = Average variance



The survey instrument for this chapter is sufficient because Cronbach alpha is greater than 0.6.

### Distribution According to Gender and Age Group of Respondent in Owena Osun and Ondo States

The distribution according to gender and age group of the populace involve in fishing activities in this chapter is presented in Figs. 3 and 4, respectively. The result revealed that all of the respondent (100%) in Owena Ondo were males, while 92% of the respondents in Owena Osun were male and 8% females. The pooled result revealed that 96% of the respondents were males while 4% were females. The high percentage of men involvement in fishing as revealed by the most of the respondents in the areas attest to high-risk associated fishing. In addition, the extensive involvement of women in post-harvest fish processing and fish trading might have accounted for their low percentage in fishing in both States inland water environs.

The mainstream of the respondent (52%) were between 21 and 31 years, 38% of the respondents were between 31 and 40 years, 8% <21 years, and 2% were between 41 and 50 years. This implies that the pooled age brackets were within the age group of 21–45 years. This age bracket is considered to be the most economical, vibrant, resourceful, and productive group when considering the energy required to carry out a tedious activity like fishing and the need to source for income and livelihood.

### Secondary Occupation and Monthly Income of Respondent in Owena Osun and Ondo State

The secondary occupation and monthly income of the populace involve in fishing activities in the areas is presented in Figs. 5 and 6, respectively.

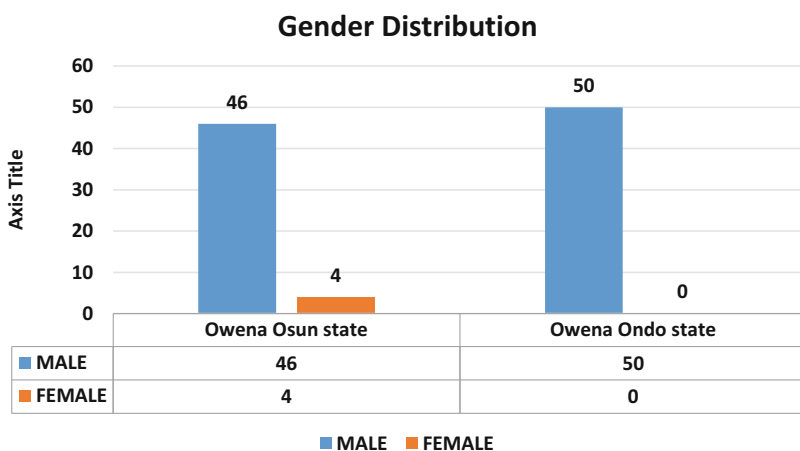
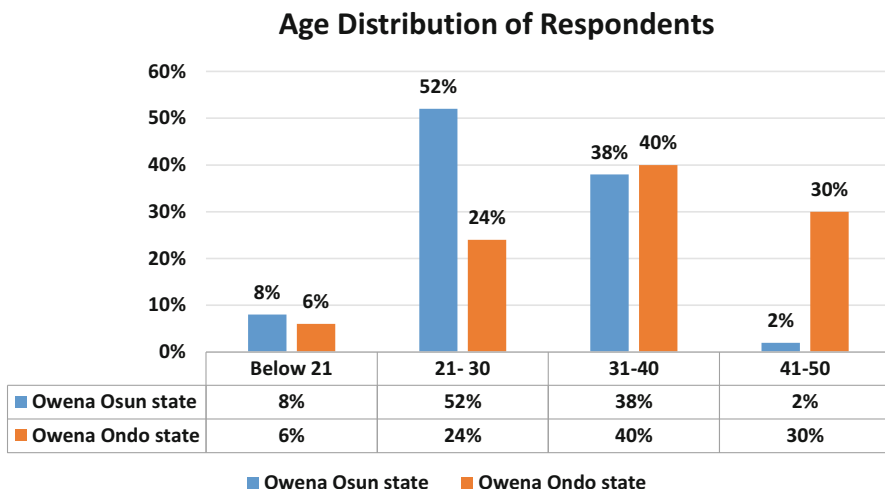
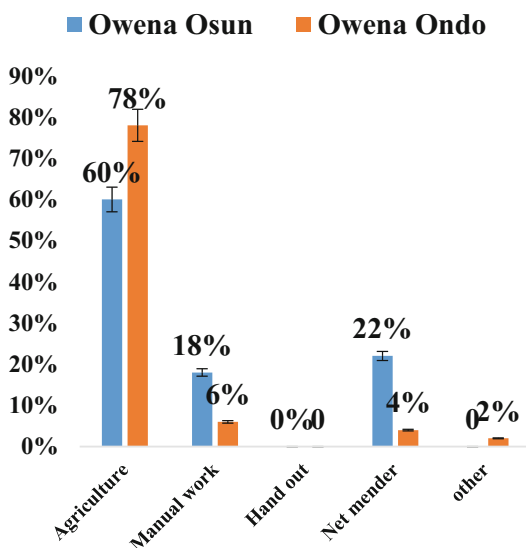


Fig. 3 Gender distribution of respondents



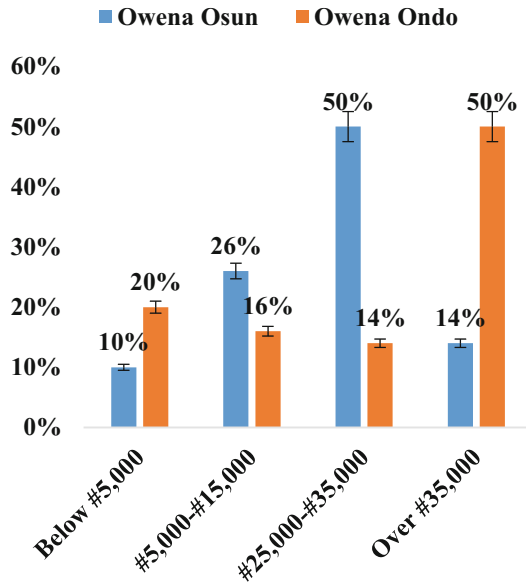
**Fig. 4** Age distribution of respondents

**Fig. 5** Secondary occupation of respondent



Agriculture was revealed as the major source of income in both States. The chapter revealed that 60% of the respondents in Owena Osun had their secondary occupation as agriculture (fishing), followed by net mending work (22%) and manual work (18%), while in Owena Ondo, agriculture as secondary occupation was 78%, followed by manual work (6%), net mending (4%), and other income sources (2%). The monthly incomes of the respondents from fishing activities as shown in this chapter were as follows: 50% of the respondents in Owena Osun earn

**Fig. 6** Income per month of respondent



between #25,000 and 35,000, 26% between #5000 and 15,000, 14% over #35,000, while 10% earn below #5000. Likewise in Owena Ondo, 50% earn over #35,000, 20% below #5000 naira, 16% between #5000 and 15,000, and 14% between 25,000 and 35,000.

The result in this chapter implies that fishing activities in the area might not be sustaining the living standard of the populace and might be the reason why most of the respondents took agriculture as their secondary occupation.

### Effect of Climate Variability on Fish Catch in Owena Ondo and Osun States

The effect of wind, rainfall, and temperature on fish catch in Owena Ondo and Osun States is presented in Table 1.

The result in this chapter revealed that variability in wind patterns often affects fish catch in the aquatic ecosystem. As shown in Table 1, 88% and 90% of the respondents observed that strong winds reduce fish catch in Owena Ondo and Osun State, respectively. During moderate wind, 2% and 10% of the respondents reported very low fish catch, 38% and 30% reported high catch, 20% and 10% observe very high catch, while 34% and 50% observe normal fish catch in Owena Ondo and Osun State, respectively. Also, the impact of waves on fish catch by respondents revealed that 52% causes regular and normal catch in the two States, while 36% and 48% cause low catch in Owena Ondo and Osun, respectively. The availability of fish for harvest in various aquatic environments is often affected by variation in wind



patterns. This often results in the destruction of fishing infrastructure, submergence/loss of fishing boats with adverse effects on fisher folks, and reduction in the number of catches. Trotman (2009) and Crandall (2009) opined that changes in wind patterns and extreme weather conditions can be damaging to fish production, distribution, abundance, and the fisheries industries as they cause destruction of the fishing gear, vessels, and biodiversity, thus becoming a major setback to the fishing community. The findings support the report of Jallow et al. (1999) who observed changes in wind pattern and adduced it to changes in climatic regimes.

There was marked variation in the rainfall pattern across the two states with different impacts on fish catch. In Owena Ondo, 46% of the respondents observed very high catch, 26% high catch, and 18% low catch during high rainfall. During moderate rainfall, 46% of the respondents observed high catch, 26% very high catch, 22% normal catch, and 6% low catch. During flooding, 66% of the respondents observed that catch is high, while 6% observe low catch. In Owena Osun, 2% of the respondents observed very high catch, 8% high catch, and 54% low catch during high rainfall. During moderate rainfall, 50% of the respondents observed high catch, 10% very high catch, 30% normal catch, and 10% low catch. 76% of the respondents observed low catch during flooding, while 20% observed high catch. Although changes in rainfall pattern have often proved to have different impacts on the duration of fishing, the high catch observed during high rainfall could be as a result of influx of fresh water which could have led to increase in fish growth and performances. In addition, many aquatic species tend to reproduce and migrate during raining seasons due to water and nutrients availability, thus supporting high biomass and catch.

Most of the respondents in both locations reported low fish catch during high and low temperature. 40% and 88% reported low fish catch during high temperature, while 19% and 6% observed high catch in Owena Ondo and Osun, respectively. Also, during low temperatures, 54% 70% of the respondents reported low fish catch in Owena, Ondo and Osun, respectively. The low fish catch during high and low temperature implies a warming trend in the areas. Changes in temperature can change the dynamics of aquatic environments, thus resulting in changes in the migration patterns of fish and reduced fish landings (African-Action 2007).

---

### **Likely Effect of Climate Variability on Fisher Folks in Owena Ondo and Osun States**

The likely effect of climate variability such as wind, rainfall, and temperature on fisher folks in both locations is presented in Table 2.

In both locations, most of the respondents (94% and 100% in Owena Ondo and Osun, respectively) observed and stated the adverse effect of strong winds on fisher folks. This impact varies from loss of fishing gear (traps and nets), sickness (body injuries), and death. Majority of the respondents (100% and 98% in Owena Ondo and Osun, respectively) preferred moderate, calm wind for their fishing activities. It was also observed by most of the respondents in both states that wave and stormy conditions lead to loss of fishing equipment.

**Table 2** Result showing the effect of climate variability on fisher folks in Owena Ondo and Osun States

Variables	Might lead to fisher folks death						Sickness						Loss of fishing gears						No effect					
	Ondo			Osun			Ondo			Osun			Ondo			Osun			Ondo			Osun		
	F	%		F	%		F	%		F	%		F	%		F	%		F	%		F	%	
Strong wind	0	0	2	4	7	14	0	0	43	86	48	96	3	6	0	0	0	0	0	0	0	0	0	0
Moderate wind	0	0	0	0	0	0	0	0	0	0	0	0	0	0	0	0	0	0	0	0	0	0	0	0
Waves	1	2	0	0	0	0	0	0	30	60	34	68	19	38	16	32	0	0	0	0	0	0	0	0
High rainfall	10	2	16	32	45	90	10	20	14	28	36	72	3	6	2	4	0	0	0	0	0	0	0	0
Moderate rain	0	0	0	0	0	0	0	0	0	0	0	0	0	0	0	0	0	0	0	0	0	0	0	0
Absence of rainfall	0	0	0	0	0	0	0	0	0	0	0	0	0	0	0	0	0	0	0	0	0	0	0	0
Flooding	1	2	22	40	31	62	15	30	13	26	39	78	9	18	2	4	0	0	0	0	0	0	0	0
High temperature	1	2	6	12	0	0	1	2	0	0	1	2	1	2	50	100	42	84	0	0	0	0	0	0
Moderate temperature	0	0	0	0	0	0	0	0	0	0	0	0	0	0	0	0	0	0	0	0	0	0	0	0
Low temperature	1	2	0	0	4	8	2	4	0	0	0	0	0	0	46	92	48	96	0	0	0	0	0	0

The results in this chapter also revealed the effect of changes in rainfall pattern in both locations. In Owena Ondo State, 90% of the respondents observed high rainfall which results into sickness such as cold and malaria from mosquito bite on the fisher folks, 28% observed the loss of fishing gear in waters, while 20% revealed fisher folks might die as a result of high rainfall. In Owena Osun, the majority of the respondents (72%) observed the loss of gear during high rainfall, 32% observed that it might lead to the death of fisher folks, while 20% observed various sickness on the fisher folks. The major impact of flooding in both locations was sickness and loss of fishing gears and death.

The adverse effect of climate variability on the fisher folks was clearly evident in this chapter. The impacts of strong wind, waves, rainfall, flooding, and temperature were strongly observed by the respondents to cause sicknesses (malaria, cholera), physical injuries, destruction/loss of fishing gears, and death from boat submergence and climatic shocks. Badjeck et al. (2009, 2010) observed the same effects in their studies and noted it to be inimical to health and safety of the fisher folks and deleterious to sustainable livelihood.

### Effect of Climate Variability on Fishing Techniques in Owena Ondo and Osun States

The effect of climate variability on fishing techniques in both locations is presented in Table 3.

This chapter revealed that most of the respondents observed the adverse effect of climate variability on the fishing techniques in both locations. During strong winds and storms, most of the respondents (59.38% and 83.33%) do fishing using other

**Table 3** Percentage of respondents on effect of climate variability on fishing techniques in Owena Ondo and Osun States

States	Ondo				Osun			
	Normal fishing method (active)		Other fishing method (passive)		Normal fishing method (active)		Other fishing method (passive)	
	F	%	F	%	F	%	F	%
Strong wind	13	40.63	19	59.38	7	16.67	35	83.33
Moderate wind	19	59.38	11	34.38	34	80.95	7	16.67
Waves	15	46.88	17	53.13	19	45.24	23	54.76
High rainfall	11	34.38	19	59.38	16	38.09	26	61.9
Moderate rain	18	56.25	14	43.75	37	88.1	5	11.9
Absence of rainfall	14	43.75	18	56.25	30	71.43	12	28.57
Flooding	14	43.75	31	62	10	23.81	32	76.19
High temperature	15	46.88	17	53.13	37	88.1	5	11.9
Moderate temperature	22	68.75	10	31.25	39	92.86	3	7.14
Low temperature	19	59.38	13	40.63	32	76.19	10	23.81

fishing method (passive method), while 40.63% and 16.67% use normal fishing method techniques (active method) in Owena Ondo and Osun, respectively. During waves, 53.13% and 54.76% use other fishing method, while 46.88% and 45.24% use normal fishing method in Owena Ondo and Osun, respectively.

The result also revealed that fishing techniques change during high rainfall as 59.38% and 61.90% use the other techniques as opposed to the usual fishing methods in Owena Ondo and Osun, respectively. During flooding, 62% and 76.19% use unusual fishing method, while 43.75% and 23.81% use normal fishing method in Owena Ondo and Osun, respectively.

Most of the respondents (53.13% and 88.10%) reported the use of other methods of fishing during high temperatures, while 46.88% and 11.09% reported the use of the usual methods of fishing in Owena Ondo and Osun, respectively.

The effect of climate variability was visible on the various methods and techniques of fishing. The techniques of fishing referred to as the normal methods of fishing include the use of cast nets, gill nets, hand lines, and beach seine nets that is the active fishing, while the other methods of fishing include trapping, long line fishing, and use of baskets, i.e., the passive fishing.

### Effect of Variability in Climate on Choice of Fishing Equipment in Owena Ondo and Osun States

The effect of climate variability on the choice of fishing equipment in both locations is presented in Table 4.

This chapter revealed that strong winds destroy 88% and 66% fishing equipment, 6% and 40% causes sinking of gears in Owena Ondo and Osun state, respectively. 66% and

**Table 4** Percentage response of respondents on the effect of climate variability on fishing equipment in Owena Ondo and Osun

Variables	Destruction of fishing gears				Sinking of fishing gears				No effect on equipment			
	Ondo		Osun		Ondo		Osun		Ondo		Osun	
	F	%	F	%	F	%	F	%	F	%	F	%
Strong wind	44	88	28	56	3	6	20	40	3	6	2	4
Moderate wind	0	0	0	0	0	0	1	2	50	100	49	98
Waves	33	66	20	40	3	6	15	30	16	32	15	30
High rainfall	5	10	15	30	37	74	36	72	12	24	5	10
Moderate rain	0	0	0	0	0	0	1	2	50	100	49	98
Absence of rainfall	0	0	0	0	0	0	2	4	50	100	48	96
Flooding	18	36	30	60	26	52	34	68	15	30	5	10
High temperature	0	0	4	8	0	0	0	0	50	100	46	92
Moderate temperature	0	0	0	0	0	0	0	0	50	100	50	100
Low temperature	0	0	0	0	0	0	0	0	50	100	50	100



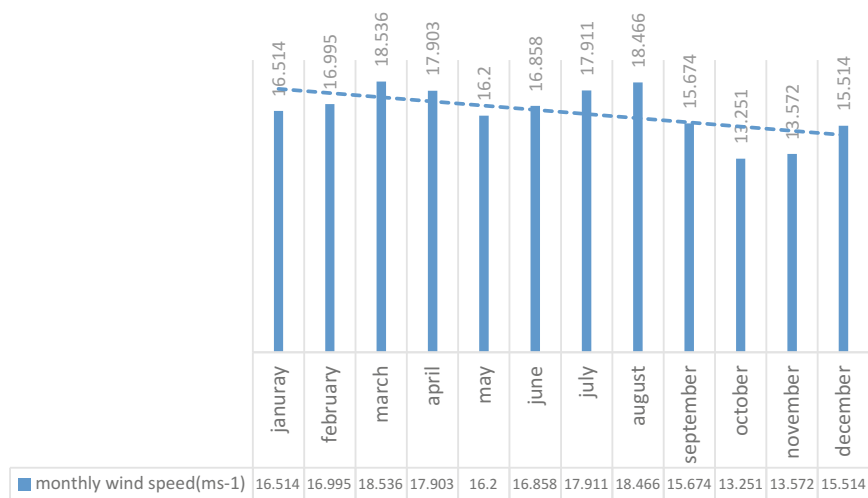
40% of the respondents revealed the impact of waves on the destruction of fishing equipment in Owena Ondo and Osun, respectively. Also, 74% and 52% of the respondents showed that fishing equipment sink during high rainfall and high flooding, respectively, in Owena Ondo, while 72% and 68% reported the same scenario in Owena Osun. The effect of climate variability on the fishing equipment was strongly observed in the areas. The loss of physical capital equipment (gears and nets) compounded with a deteriorating financial asset base from strong winds, waves, and high rainfall would have had a significant effect on livelihoods in the areas.

The periods of moderate winds and rainfall were observed by the respondents to be the most convenient and secure for fishing equipment. However, temperature variations were observed to have no effect on the fishing equipment in both locations.

### Climatic Trends in Owena River Between 2008 and 2017: Wind Trends and Rainfall Pattern in Owena Osun State Between 2008 and 2017

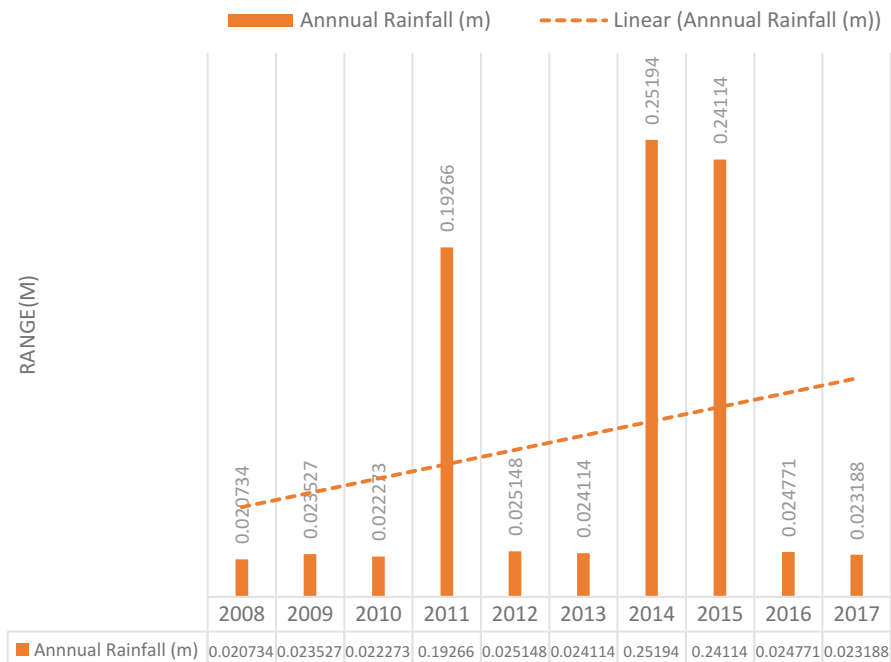
The statistical records on wind and rainfall data were obtained from the Department of Meteorological/Climate Science Technology Department of the Federal University of Technology, Akure, Nigeria, as presented in this chapter. Figure 7 shows the monthly trend of wind data for Owena Osun (2008–2017); Fig. 8 shows annual rainfall pattern/data for Owena Osun State (2008–2017); and Fig. 9 shows

#### MONTHLY WIND SPEED(MS-1) OF OWENA OSUN FROM 2008-2017



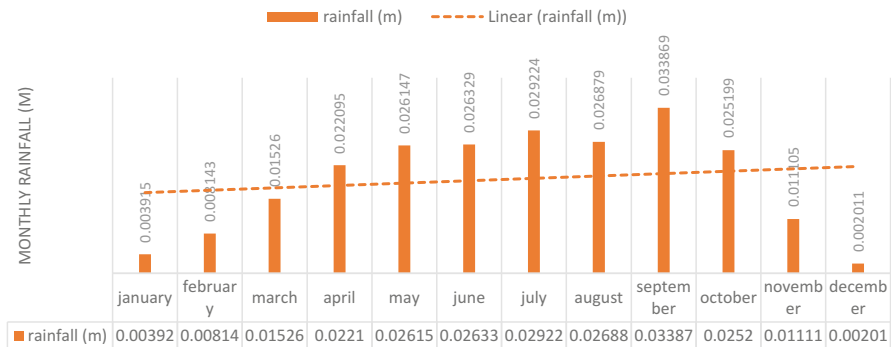
**Fig. 7** Monthly trend of wind data for Owena: 2008–2017. (Source: Climate Records of Department of Meteorological/Climate Science Technology, The Federal University of Technology, Akure, Nigeria, 2018)

### ANNUAL RAINFALL (M)



**Fig. 8** Annual rainfall pattern/data for Owena Osun State: 2008–2017. (Source: Climate Records of Department of Meteorological/Climate Science Technology, The Federal University of Technology, Akure, Nigeria, 2018)

### MONTHLY RAINFALL OF OWENA ONDO STATE FROM 2017-2018



**Fig. 9** Monthly rainfall pattern/data for Owena Osun State: 2008–2017. (Source: Climate Records of Department of Meteorological/Climate Science Technology, The Federal University of Technology, Akure, Nigeria, 2018)

monthly rainfall pattern/data for Owena Osun State: 2008–2017. The record reveals over the 10 years duration of the wind trends and rainfall pattern. For the 10 years under consideration (between 2008 and 2017), a decreased trend in the average wind speed across the months from September to December was observed. The highest wind speed was in the month of March and the lowest wind speed in the month of June.

Also, the recorded data on rainfall from 2008 to 2017 showed an increasing trend in annual rainfall. The irregularity in rainfall pattern from these records points a clear indication to weather and climate variability; some years like 2014, 2015, and 2011 have exceptionally high average rainfall. These trends certainly will affect fishing activities. More so, fluctuation in the pattern of rainfall will have both positive and negative impacts on fish catch in the inland Owena water. As opined by Adeleke and Fagbenro (2013), fluctuations in the climate variables will pose adverse effect on the fisher folks and fisheries activities in the coastal areas of Nigeria. In addition, strong winds according to Jallow et al. (1999) have adverse effects on fishing infrastructure as fishing vessels get destroyed, lost, or submerge

---

## Conclusion

This chapter revealed that climate variability has affected fishing activities, fisheries resources, and structures in Owena Osun and Ondo State. The potential impacts of climate change range from impact on the fisher folk, some of which are loss and destruction of fishing equipment's, impact on health, alteration in fishing duration, alteration in fish catch, and change in fishing techniques and equipment. It was also observed that the success and optimum benefit derived from fishing is dependent on favorable climatic conditions. Fisher folk and fishermen that depend on fisheries resources as a source of livelihood will continue to be at risk if proper preventive strategies and measures against the adverse effect of climate and food insecurity are not set in place. This chapter, therefore, recommends the need for extension education and innovation on the various possible strategies, fishing techniques, equipment, and beneficial knowledge to help fisher folks to be able to counter or lessen the adverse effect of climate variability in order for fisher folks to attain maximum sustainable catch.

---

## References

- Adeleke ML, Balogun AA (2013) Occurrence of climate change and its effects on the fishing activities in the coastal region of Ondo State, Nigeria. *Int J Dev Econ Sustain* 1(1):1–13
- Adeleke ML, Fagbenro OA (2013) Livelihood diversification and operational techniques of the Artisanal Fisherfolks in the coastal region of Ondo State, Nigeria. *Int J Innov Res Dev* 2(1):262–273. ISSN 2278-0211(online)
- Adeleke ML, Omoboyeje VO (2016) Effects of climate change on aquaculture production and management in Akure Metropolis, Ondo State, Nigeria. *Niger J Fish Aquac* 4(1):50–58
- Africa-Action (2007) Africa policy outlook. Available at <http://www.africaaction.org>

- Agbebi FO, Omoniyi AO (2011) Effect of climate change and coping strategies on socio economic status of fisher folks in Ilaje-Ese Odo local government areas of Ondo State, Nigeria. *Int J Sci Nat* 2(2):339–343
- Allison EH, Perry AL, Badjeck M-C, Adger WN, Brown K, Conway D (2009) Climate change and fisheries: a comparative analysis of the relative vulnerability of 132 countries. *Fish Fish* 10 (2):173–196
- Badjeck M-C, Mendo J, Wolff M, Lange H (2009) Climate variability and the Peruvian scallop fishery: the role of formal institutions in resilience building. *Clim Chang* 94(1–2):211–232
- Badjeck M-C, Allison EH, Halls AS, Dulvy NK (2010) Impacts of climate variability and change on fishery-based livelihoods. *Mar Policy* 34:375–383
- Cheung WWL, Lam VWY, Sarmiento JL, Kearney K, Watson R, Pauly D (2009) Projecting global marine biodiversity impacts under climate change scenario. *Fish Fish* 10:235–251
- Crandall A (2009) Local perceptions of water variability and wetlands in Lake Victoria. Institute for the Study of Diplomacy Edmund A. Walsh School of Foreign Service Georgetown University. Washington DC, USA
- Idowu AA, Ayoola SO, Opele AI, Ikenweiwe NB (2011) Impact of climate change in Nigeria. *Iran J Energy Environ* 2(2):145–152
- Jallow BP, Toure S, Barrow MMK, Matheiu AA (1999) Coastal zone of the Gambia and the Abuja Region in cote d'Ivoire: sea rise and vulnerability, response strategies, and adaptation options. *Clim Res* 12(2–3):129–138
- Perry RI, Ommer RE, Allison E, Badjeck MC, Barange M, Hamilton L (2009) The human dimensions of marine ecosystem change: interactions between changes in marine ecosystems and human communities. In: Barange M, Field C, Harris R, Hofmann E, Perry I, Werner C (eds) *Global change and Marine ecosystems*. Oxford University Press, Oxford
- Trotman A, Gordon RM, Hutchinson SD, Singh R, McRae-smith D (2009) Policy responses to GEC impacts on food availability and affordability in the Caribbean community. *Environ Sci Policy* 12(4):529–541
- World Fish Center (WFC) (2006) The threat to fisheries and aquaculture from climate change. World Fish Center policy brief. WFC, Penang, p 8

**Open Access** This chapter is licensed under the terms of the Creative Commons Attribution 4.0 International License (<http://creativecommons.org/licenses/by/4.0/>), which permits use, sharing, adaptation, distribution and reproduction in any medium or format, as long as you give appropriate credit to the original author(s) and the source, provide a link to the Creative Commons license and indicate if changes were made.

The images or other third party material in this chapter are included in the chapter's Creative Commons license, unless indicated otherwise in a credit line to the material. If material is not included in the chapter's Creative Commons license and your intended use is not permitted by statutory regulation or exceeds the permitted use, you will need to obtain permission directly from the copyright holder.





# Climate Change Impact on Climate Extremes and Adaptation Strategies in the Veve Catchment, Ghana

# 95

Isaac Larbi, Clement Nyamekye, Fabien C. C. Hountondji,  
Gloria C. Okafor, and Peter Rock Ebo Odoom

## Contents

Introduction .....	1938
Description of the Study Area and Methodology .....	1940
Observation and Climate Change Scenario Datasets .....	1941
Climate Extreme Indices Analysis .....	1942
Presentation of Results and Discussion .....	1942
Annual Rainfall and Temperature Projections and Trends .....	1942

This chapter was previously published non-open access with exclusive rights reserved by the Publisher. It has been changed retrospectively to open access under a CC BY 4.0 license and the copyright holder is “The Author(s)”. For further details, please see the license information at the end of the chapter.

I. Larbi (✉)

Climate Change and Water Resources, West African Science Service Centre on Climate Change and Adapted Land Use (WASCAL), Université d’Abomey-Calavi, Cotonou, Benin

School of Sustainable Development, University of Environment and Sustainable Development, Somanya, Ghana

Department of Civil Engineering, Faculty of Engineering, Koforidua Technical University, Koforidua, Ghana

e-mail: [larbi.i@edu.wascal.com](mailto:larbi.i@edu.wascal.com)

C. Nyamekye

Department of Civil Engineering, Faculty of Engineering, Koforidua Technical University, Koforidua, Ghana

F. C. C. Hountondji

Faculté d’Agronomie, University of Parakou, Parakou, Benin

G. C. Okafor

Department of Civil Engineering, Nigeria Maritime University, Delta–State, Nigeria

P. R. E. Odoom

Climate Change and Water Resources, West African Science Service Centre on Climate Change and Adapted Land Use (WASCAL), Université d’Abomey-Calavi, Cotonou, Benin

© The Author(s) 2021

W. Leal Filho et al. (eds.), *African Handbook of Climate Change Adaptation*,  
[https://doi.org/10.1007/978-3-030-45106-6\\_95](https://doi.org/10.1007/978-3-030-45106-6_95)

1937

Trends and Projected Changes in Extreme Rainfall Indices .....	1943
Temperature Extreme Indices Projections and Trends .....	1944
Climate Change and Climate Extreme Impacts at the Study Region .....	1946
Existing and Recommended Adaptation Strategies to Address Poverty and Ensure Sustainable Livelihoods in the Catchment .....	1949
Conclusions .....	1950
References .....	1950

## Abstract

Climate change impact on rainfall and temperature extreme indices in the Vea catchment was analyzed using observation and an ensemble mean of bias-corrected regional climate models datasets for Representative Concentration Pathway (RCP 4.5) scenario. Rainfall extreme indices such as annual total wet-day precipitation (PRCPTOT), extremely wet days (R99P), consecutive wet days (CWD), consecutive dry days (CDD), and temperature indices such as warmest day (TXx) and warmest night (TNx) from the Expert Team on Climate Change Detection Monitoring Indices (ETCCDMI) were computed for both the historical (1986–2016) and future (2020–2049) period using the RCLimdex. The parametric ordinary least square (OLS) regression approach was used to detect trends in the time series of climate change and extreme indices. The results show an increase in mean annual temperature at the rate of 0.02 °C/year and a variability in rainfall at the catchment, under RCP 4.5 scenario. The warmest day and warmest night were projected to increase by 0.8 °C and 0.3 °C, respectively, in the future relative to the historical period. The intensity (e.g., R99p) and frequency (e.g., CDD) of extreme rainfall indices were projected to increase by 29 mm and 26 days, respectively, in the future. This is an indication of the vulnerability of the catchment to the risk of climate disasters (e.g., floods and drought). Adaptation strategies such as early warning systems, availability of climate information, and flood control measures are recommended to reduce the vulnerability of the people to the risk of the projected impact of climate extreme in the future.

## Keywords

Climate change · Climate models · Early warning systems · Climate extreme indices · Vea catchment

## Introduction

In the last century, global surface temperature has increased by 0.71 °C with significant warming observed in many regions (Trenberth et al. 2007). This increase in global surface temperature reveals more warming of land than the oceans and has diverse consequences on water resources and the livelihood of people. In view of this, much attention has been given to climate change and extremes over the past decades (New et al. 2006; Larbi et al. 2018; Adeyeri et al. 2019) due to its intense impact on natural and human systems. At the study region, the high variability in

rainfall has also resulted in higher frequency of flood and drought events, putting the socioeconomic activities at risk (Awotwi et al. 2015).

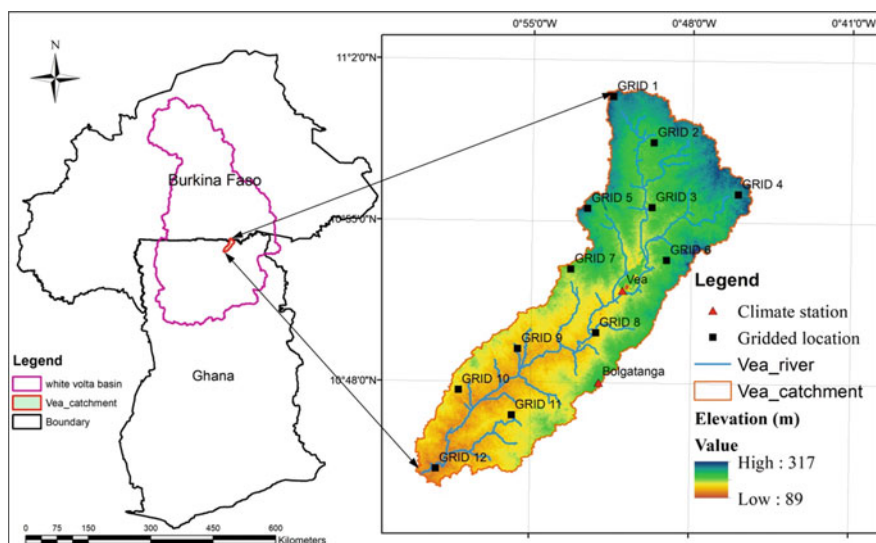
The impact of climate change on climate extremes and other sectors require tools for its assessment, and the most common approach for the assessment is the use of climate model outputs. Though Global Circulation Models (GCMs) have been widely used for various climate change studies (Minville et al. 2009; Chen et al. 2012; Panday et al. 2015), it is not suitable for analyzing the projections on a regional or local scale due to its coarse resolution nature (Xu 1999; Maraun et al. 2010; Seager and Vecchi 2010). In West Africa regions, GCMs are unable to represent key features of the West African monsoon (WAM) such as the Africa Easterly Waves (AEWs), Africa Easterly Jets (AEJ), and Tropical Easterly Jets (TEJ) (Sylla et al. 2013). Regional climate models (RCMs) are therefore used in climate change studies because of its ability to accurately take into account orography, thus providing a better reproduction of regional climates (Sylla et al. 2013).

Extreme climatic events such as heat waves, floods, and droughts affect lives and livelihoods of people over varied regions (Alexander et al. 2006). Floods and droughts generate socioeconomic effects such as hunger, habitat, and infrastructure destruction. Over 40% of the populace has encountered hunger situations, that resulted from failure of one-third of crop produced when compared to 2010 data, leading to humanitarian appeals (Sarr 2012; FAO 2013). These and other ensuing impacts have necessitated the analysis of changes in future climate extremes necessary in reducing potential social, economic, and ecological consequences (Amuzu et al. 2018; Bohle et al. 2018). This need has necessitated studies in the analysis of past trends and the prediction of the occurrence of extreme climate events on rainfall and temperature using different approaches. Several studies have therefore achieved this by the use of RCMs. This model has been frequently used for climate change impact studies (Zhang et al. 2008) and future extreme climate projections analysis (Tomassini and Jacob 2009).

In West Africa, M'Po et al. (2017) assessed climate change impact on rainfall extremes over the Ouémé River Basin in Benin using RCM. The results showed a decrease in extremely heavy precipitation and annual total wet-day precipitation in most stations for the future 2015–2050. The Veve catchment in Ghana is seen as one of the vulnerable areas to climate change and is faced with issues of climate shocks such as flood and drought. This has devastating effects on various sectors of the economy particularly water resources and agriculture. However, information regarding climate change and climate extremes which are vital to improve societal awareness and preparedness is limited in the Veve catchment. To this end, understanding trends and variations of historical and future climatic variables is pertinent for the future development and sustainable water resources management in the catchment (Ogountundé et al. 2006). This chapter assesses the impact of climate change on rainfall and temperature extreme indices in the Veve catchment in the Upper East Region of Ghana. This is based on the Representative Concentration Pathways (RCP 4.5) scenario, which would recommend adaptation strategies required at the community level to reduce the vulnerability of the people to the risk of climate change and extreme events in the future.

## Description of the Study Area and Methodology

This section describes the area where the study was conducted, the data used, and the methodology applied to achieve the aim of the study. The Vea catchment, one of the sub-catchments within the White Volta basin (WVB), is located between latitudes  $10^{\circ} 30'N$ – $11^{\circ} 08'N$  and longitudes  $1^{\circ} 15'W$ – $0^{\circ} 50'E$  (Fig. 1). It has an area of about 305 km<sup>2</sup> and covers mainly the Bongo and Bolgatanga districts in the Upper East Region of Ghana, with a small portion over the south-central part of Burkina Faso. The climate of the catchment is controlled by the movement of the Inter-tropical Discontinuity (ITD) over the land that dominates the climate of the entire West African region (Obuobie 2008). Located in a semiarid agroclimatic zone, the catchment covers three agroecological zones: the Savanna and Guinea Savanna zones in Ghana, and north Sudanian Savanna zone in Burkina Faso (Forkuor 2014). It is characterized by a unimodal rainfall regime from April/May to October with a mean annual rainfall of 957 mm which normally peaks in August (Larbi et al. 2018). The temperature is uniformly high with a mean value of 28.5 °C while potential evapotranspiration in the catchment exceed monthly rainfall for most part of the year, except the three wettest months of July, August, and September (Limantol et al. 2016). It is characterized by fairly low relief with elevation ranging between 89 m and 317 m (Fig. 1) and mainly dominated by cropland followed by grassland interspersed with shrubs and trees and woodland (closed/open).



**Fig. 1** Map of the Vea catchment showing the station and gridded precipitation locations within a 12 km grid



## Observation and Climate Change Scenario Datasets

Observed daily rainfall, maximum and minimum temperature within the Veia catchment from 1986 to 2016 for two climate stations (Veia and Bolgatanga) were obtained from the West African Science Service Centre on Climate Change and Adapted Land Use (WASCAL) research center and Ghana Meteorological Agency. Additional 12 (Fig. 1) gridded daily precipitation data at  $0.05^\circ$  spatial resolution from Climate Hazards Group InfraRed Precipitation with Station data (CHIRPS) were also downloaded from <http://chg.geog.ucsb.edu/data/chirps> (Funk et al. 2015). CHIRPS incorporate satellite imagery with in-situ station data to create gridded rainfall time series. The performance of the CHIRPS data in reproducing the climatology of the Veia catchment has been evaluated in previous research (Larbi et al. 2018). According to Larbi et al. (2018), the CHIRPS data is able to reproduce well both the seasonal and annual rainfall pattern of the Veia catchment, and the validation resulted in a very high correlation coefficient ( $r = 0.99$ ) and a Nash–Sutcliffe efficiency of 0.9.

Four RCMs datasets (Table 1) within the CORDEX-Africa experiment and Weather Research and Forecasting (WRF) models were obtained from both CORDEX-Africa website and WASCAL geoportal (Heinzeller et al. 2016), respectively. The CORDEX-Africa RCMs have been selected based on its ability to simulate the basic climatological features in West Africa (Kim et al. 2013). The WRF simulations were produced by the Karlsruhe Institute of Technology, Institute of Meteorology and Climate Research, Atmospheric Environmental Research (KIT/IMK-IFU), Germany, and the West African Science Service Centre on Climate Change and Adapted Land Use (WASCAL) regional climate simulations. The WRF (WRF-H and WRF-G) simulations were downscaled from two GCMs namely: the General Fluid Dynamics Laboratory Earth System Model (GFDL-ESM 2 M) and the Hadley Global Environment Model (HadGEM2-ES) using the Weather Research and Forecasting Model (WRFv3.5.1). A detailed technical description and parameterization of the WRF models have been reported by Heinzeller et al. (2017). The CORDEX-Africa RCMs (REMO2009 and KNMI-RACMO22T) and the WRF models were selected due to its remarkable skills in reproducing the climatology of the Veia catchment for the period 1981–2005 (Larbi et al. 2020). The WRF models skills have also demonstrated to do well in terms of rainfall distribution in a study conducted within West

**Table 1** Description of the CORDEX-Africa and WRF models whose ensemble mean was used

GCMs	RCMs	Institution	Resolution
ICHEC-EC-EARTH	REMO2009	Max Planck Institute – Computational methods in systems and control theory (MPI-CSC), Germany	50 km
ICHEC-EC-EARTH	KNMI-RACMO22T	Koninklijk Nederlands Meteorologisch Instituut (KNMI)	50 km
HadGEM2-ES	WRF-H	WASCAL / KIT/IMK-IFU	12 km
GFDL-ESM2M	WRF-G	WASCAL / KIT IMK-IFU	12 km

Africa by Bessah et al. (2018). Details on the RCMs evaluation and bias-correction can be found in Larbi et al. (2020). The ensemble mean of the bias-corrected RCMs output used consist of daily rainfall and temperature for the future (2020–2049) under Representative Concentration Pathway (RCP4.5) climate change scenario.

## Climate Extreme Indices Analysis

Several climate extreme indices have been developed by the Expert Team on Climate Change Detection Monitoring Indices (ETCCDMI) for understanding climate extremes and are widely used in several regions (Mouhamed et al. 2013; Soro et al. 2016; M'Po et al. 2017). Six of the indices were adopted. The selected rainfall and temperature extreme indices (Table 2) were computed for each climate location for both the historical (1986–2016) and future (2020–2049) period on the interface of R software using RCLimdex. The historical extreme indices was computed using climate observation data while the future climate extreme indices were computed based on the ensemble mean of the RCMs data for the RCP 4.5 climate change scenario. The computed rainfall and temperature extremes indices at the annual scale were analyzed at spatial and temporal scale using the inverse distance weighting (IDW) technique (Feng-Wen and Chen\_Wuing 2012). Trends in the climate extreme indices time series were computed based on the parametric linear regression approach (M'Po et al. 2017).

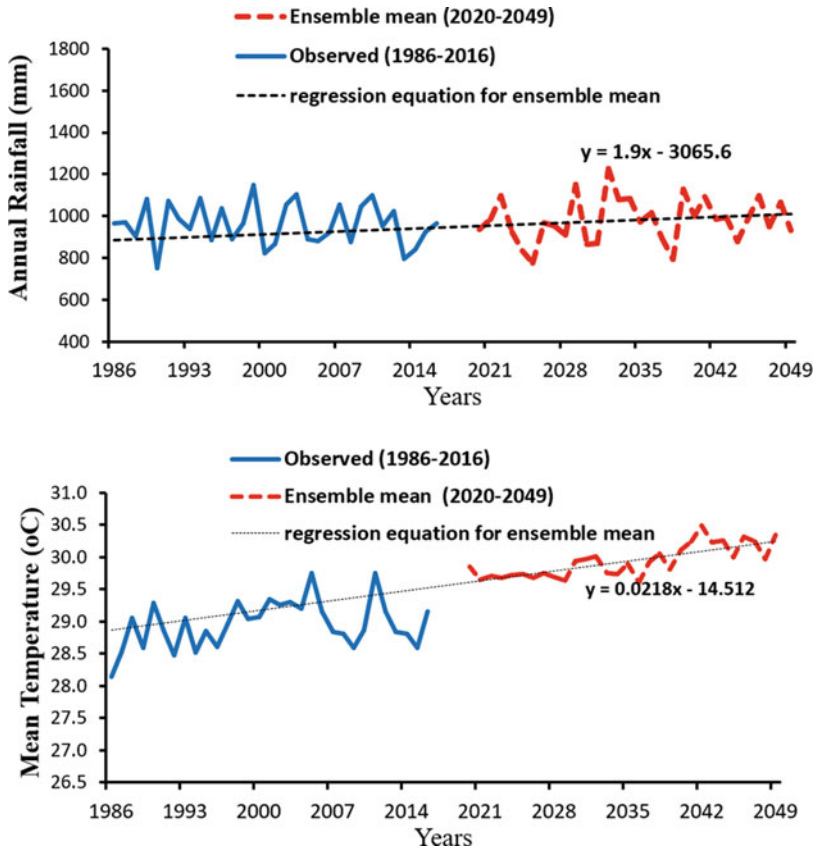
## Presentation of Results and Discussion

### Annual Rainfall and Temperature Projections and Trends

The results for the projections of mean annual rainfall and temperature in the Veacatchment by the ensemble mean of the RCMs under the RCP4.5 scenario is shown in Fig. 2 and Table 3. The ensemble mean of the RCMs shows an increase in mean annual rainfall and temperature by 22.6 mm (2.4%) and 1.3 °C, respectively, for the

**Table 2** Climate extreme indices

Indices	Descriptive name	Definition	Units
PRCPTOT	Annual total wet-day precipitation	Annual total precipitation from days $\geq 1$ mm	mm
R99p	Extremely wet days	Annual total precipitation on the days when daily PRCP $>99$ th percentile	mm
CWD	Consecutive wet days	Maximum number of consecutive days with PRCP $\geq 1$ mm	days
CDD	Consecutive dry days	Maximum number of consecutive days with PRCP $< 1$ mm	days
TXx	Warmest day	Annual maximum value of the daily max temperature	°C
TNx	Warmest night	Annual maximum value of daily min temperature	°C



**Fig. 2** Mean annual rainfall and temperature projection for the Veia catchment in the future (2020–2049) under RCP 4.5 scenario relative to the 1986–2016 period

period 2020–2049 relative to the baseline (1986–2016) period. An increasing trend in the future annual rainfall and temperature was found to be at the rate of 1.9 mm/year and 0.02 °C/year.

### Trends and Projected Changes in Extreme Rainfall Indices

The results for the extreme rainfall indices (PRCPTOT, CWD, CDD, and R99p) projected by the ensemble mean of the RCMs under RCP4.5 scenario relative to the baseline (1986–2016) period are shown in Table 4 and Fig. 3. The annual total precipitation (PRCPTOT) is projected to increase from 951.9 mm to 952.1 mm (Table 4) at an annual rate of 2.2 mm/year (Fig. 3a). Extremely wet days (R99p) is projected to increase by 29.1 mm; however, a decreasing trend at a rate of 0.77 mm/year is projected in the future 2020–2049 (Fig. 3d). Unlike consecutive dry days

**Table 3** Mean annual rainfall and temperature projections for the Vea catchment relative to the baseline period

Variables	Baseline (1986–2016)	RCP4.5 (2020–2049)	Change
Tmax (°C)	34.6	35.9	1.3
Tmin (°C)	22.6	24.0	1.4
Tmean(°C)	28.6	29.9	1.3
Rainfall (mm)	958.5	981.1	2.4%

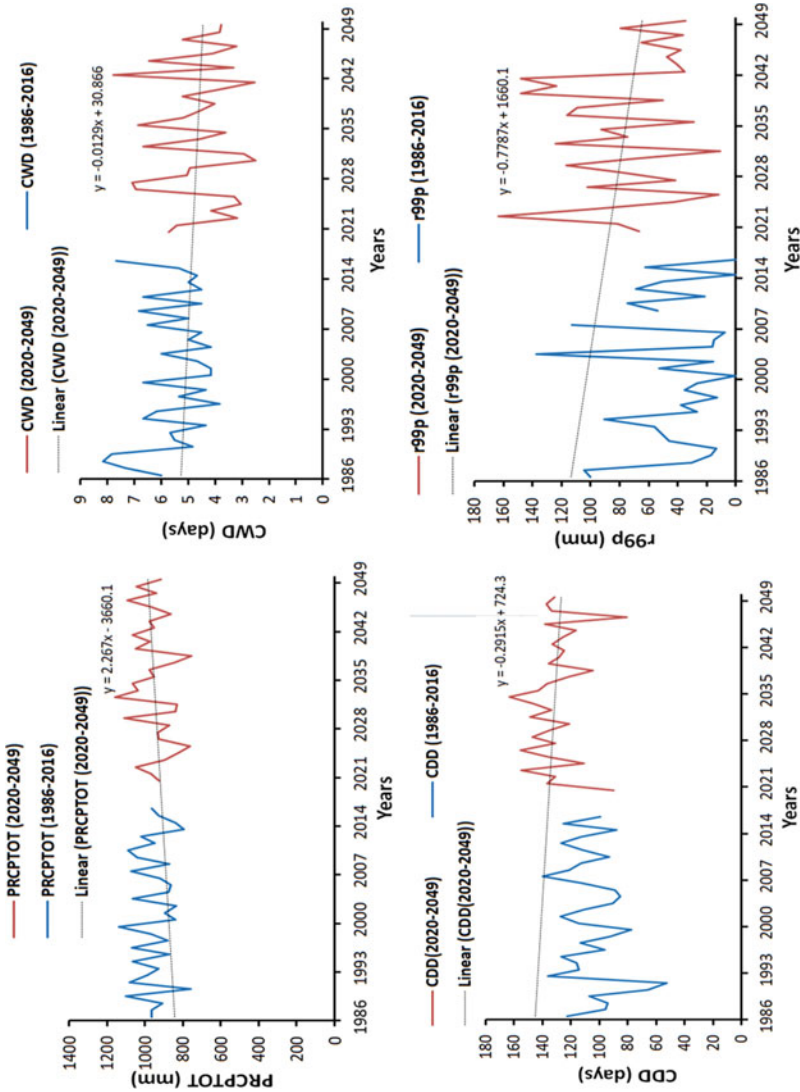
**Table 4** Projected changes in mean annual climate extreme indices at the Vea catchment

Climate extreme indices	Baseline (1986–2016)	RCP4.5 (2020–2049)	Change
PRCPTOT (mm)	951.9	952.1	0.2
R99p (mm)	46.6	75.7	29
CWD (days)	5	4	−1
CDD (days)	105	131	26
TXx (°C)	41.5	42.3	0.8
TNx (°C)	28.9	29.2	0.3

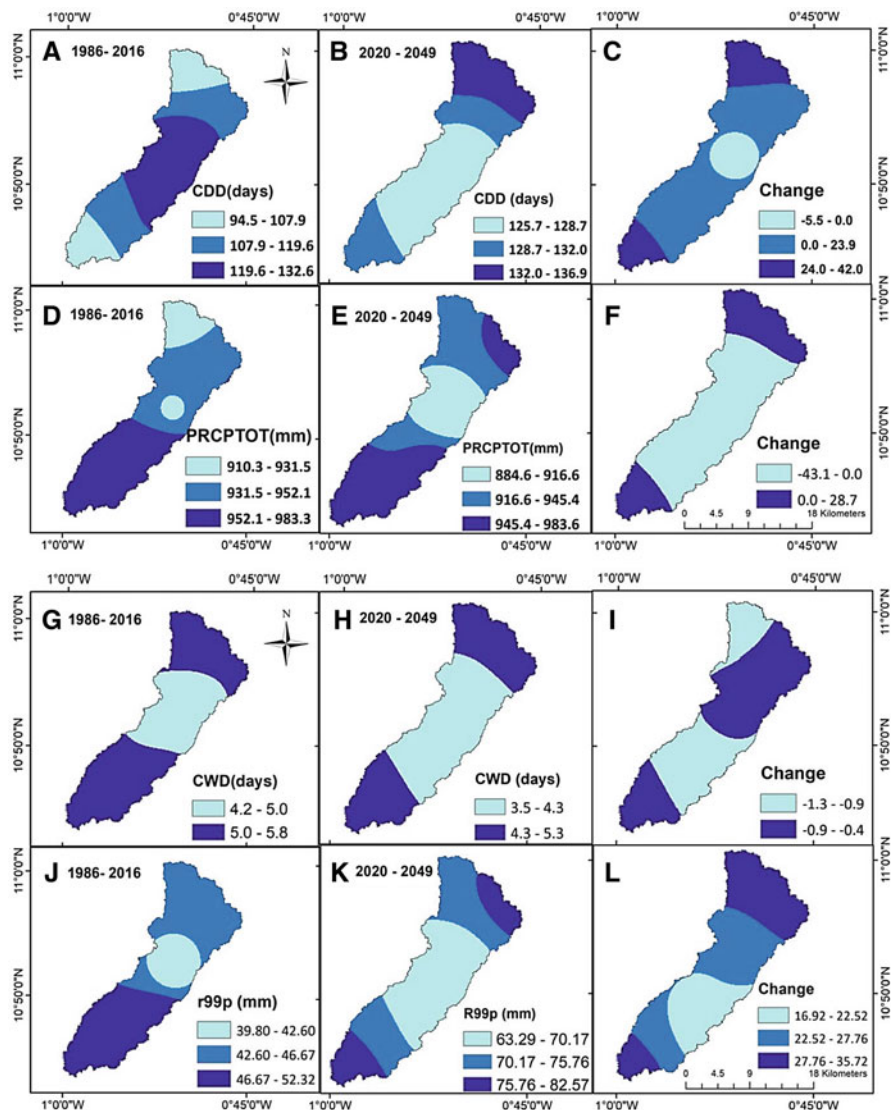
(CDD) which is projected to increase from 105 to 131 days, consecutive wet days (CWD) is projected to decrease by 1 day in the future 2020–2049 (Table 4). The spatial distribution of the extreme rainfall indices (Fig. 4) indicates a projected increase in CDD in most part of the catchment, with the exception of the center parts of the catchment that shows a decrease of 5 days (Fig. 4c). The PRCPTOT is projected to decrease in most parts of the catchment except the extreme north and south which shows an increase of 28.7 mm (Fig. 4f). R99p is projected to increase in all parts of the catchment especially in the northern and southern parts and will range from 27.7 to 35.7 mm (Fig. 4L). Unlike R99p, CWD is projected to decrease in the entire catchment in the range of −3.4 to −0.4 days (Fig. 4I).

## Temperature Extreme Indices Projections and Trends

The time series of the projected extreme temperature indices (TXx and TNx) and its spatial distribution are shown in Figs. 5 and 6, respectively. As shown in Table 4, the warmest day (TXx) is projected to increase by 0.8 °C from 41.5 °C to 42.3 °C. The warmest night (TNx) is also projected to increase from 28.9 °C to 29.2 °C. The future trend analysis of the extreme temperature indices shows an increasing trend in both TXx and TNx at a rate of 0.04 and 0.01 °C/year, respectively. At spatial scale, TXx is projected to increase in the entire catchment for the period 2020–2049, with a higher increase in the southern part of the catchment in the range of 0.79 to 1.29 °C. The TNx is also projected to increase in the range of 0.0 °C to 0.48 °C in the greater part of the Vea catchment.



**Fig. 3** Trend analysis of extreme rainfall indices: (a) PRCPTOT, (b) CWD, (c) CDD, and (d) r99p at the Veia catchment for the historical (1986–2016) and future (2020–2049) period

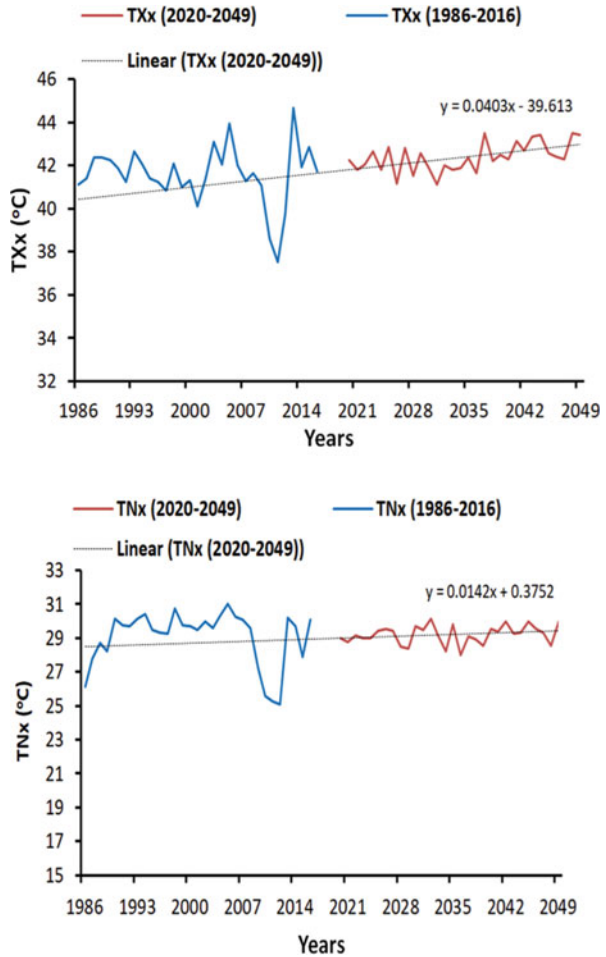


**Fig. 4** Spatial distribution of the projected changes in the extreme rainfall indices: (a) CDD, (b) PRCPTOT, (c) CWD, and (d) r99p in the Veia catchment

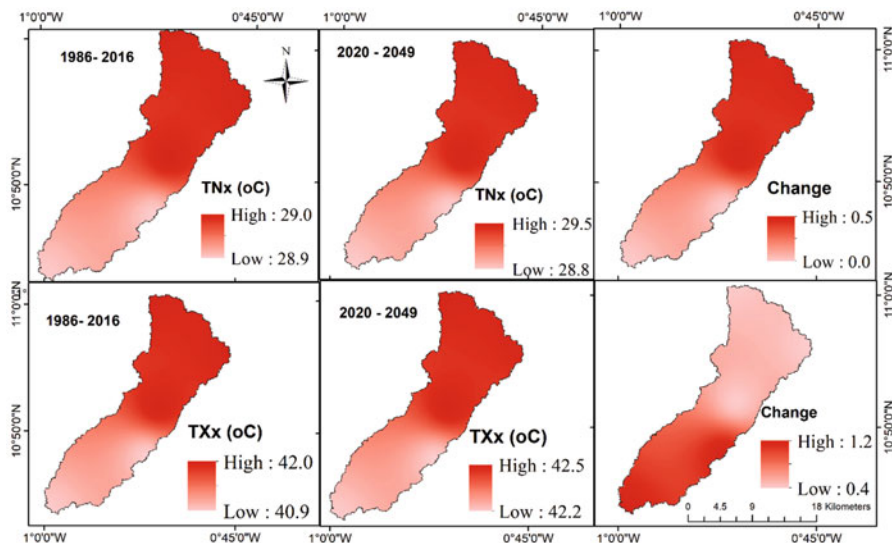
### Climate Change and Climate Extreme Impacts at the Study Region

The agroclimatic zone of the Veia catchment is characterized as semiarid region in West Africa and can influence growth when managed efficiently. With the expected increase in precipitation and temperature, there is a likelihood of potential risk to

**Fig. 5** Trend analysis of extreme temperature indices for TXx and TNx in the Veua catchment for the historical and future period



natural disasters and destruction of infrastructure which would have environmental, economic, and societal implications (Gobiet et al. 2014). The climate analysis performed on the daily rainfall and temperature series for the historical and future period provides evidence that the Veua catchment would be affected by climate change and warm extremes based on the indices analyzed with warming more pronounced during the day than the night. Although in Ghana climate change projections vary considerably among different models, there is a consensus on the evidence of increasing temperature across the country. The mean annual temperature at the Veua catchment is projected to increase by 1.3 °C for the period 2020–2049. This finding is in line with observations reported by other climate change studies (e.g., McSweeney et al. 2010a; De Pinto et al. 2012). Additionally, a study by De Pinto et al. (2012) reported a projected increase in the mean annual temperature of Ghana



**Fig. 6** Spatial distribution of the projected changes in the TNx and TXx temperature indices relative to the baseline (1986–2016) period

in the range of 1.0–3.0 °C by 2060 and by 1.5–5.2 °C by 2090, with more rapid increases expected in the northern sector of the country. Similar increase in temperature of 0.6 °C, 2.0 °C, and 3.9 °C by the year 2020, 2050, and 2080, respectively, in Ghana has also been projected by the Ministry of Environment Science, Technology and Innovation of Ghana [MESTI] (2013). These projections in temperature are noticed to be across all regions in the country with a rapid increase in the northern sector (World Bank 2010). However, rainfall projections in Ghana are characterized with greater uncertainties with some models predicting an increase while others a decrease (McSweeney et al. 2010b).

In terms of climate extremes, the study region has witnessed periodic extreme climate shocks and disasters such as high temperature, highly variable and erratic rainfall, and long spells of droughts (Kanlisi and Arkum 2013). According to EPA (2007), such extreme weather events are expected to intensify in the region by 2080. The ensemble mean of the four climate models projected a nonsignificant increase in the mean annual rainfall; however, there exist spatial variations in the annual total rainfall (PRCPTOT), CWD, and CDD with some part of the Veua catchment indicating an increase while other parts indicate a decrease in the future period. These projections in climate change and extremes would have serious socioeconomic impacts on rural farmers in Ghana whose livelihoods depend largely on rainfall (Abeygunawardena et al. 2003; Fosu-Mensah et al. 2012). The changes in climate would affect agriculture and other sectors such as water resources, especially in the Upper East Region of Ghana where the Veua catchment is located (Gyasi et al. 2006). The projected warming trend at the Veua catchment leads to a higher evaporative demand from water bodies and irrigated crops in the future. Limantol et al. (2016)



indicated that temperature and evapotranspiration have been on the increase in the Veia catchment. And according to Ofori-Sarpong (2001), the increase in evapotranspiration could lead to soil moisture deficit and poor crop yield, particularly when there is no corresponding significant increase in rainfall. Also, evapotranspiration propelled by temperature will majorly affect agriculture through droughts and soil moisture deficits (Limantol et al. 2016).

---

### **Existing and Recommended Adaptation Strategies to Address Poverty and Ensure Sustainable Livelihoods in the Catchment**

In sub-Saharan Africa, adapting to the impact of climate change on agriculture and other sectors of the economy has become a major concern to various stakeholders with special emphasis on improving adaptive capacity (Apata 2011). The projected climate change and extremes at the Veia catchment underscore the need to put in place appropriate adaptation measures to foster resilience to climate change in order to enhance water security and livelihood of the people within the area. In the Veia catchment, Limantol et al. (2016) examined farmers' perceptions and adaptation practices to climate change and variability, and noticed that farmers are aware of climate change and are adopting strategies to cope with the effects. At the catchment, some farmers use rain-fed practices to adjust to climate variability by varying crop types via rotation without fertilizer, while others employ irrigation practices to offset climate variability with a greater use of fertilizer application. According to Limantol et al. (2016), farmers identified irrigation development (access to water), followed by access to credit and health services as the most urgent needs for adaption to climatic change in the Veia catchment. Similarly, Kumasi et al. (2017) also reported that, the farmers in the Upper East Region of Ghana mostly practice crop selection, changes to planting dates and density, communal pooling (e.g., labor or income sharing across households), and traditional irrigation techniques as adaptation strategies to climate change. Additionally, Lawson et al. (2019) investigated the intersectional perceptions and adaptation strategies of women farmer in dealing with climate change in semiarid regions of Ghana. It was revealed that women farmers perceived the occurrence of climate change in the community and have incorporated some adaptation measures to counter its impacts. These adaptation strategies include changing planting dates, mixed farming, intercropping, planting early maturing varieties, composting, and seeking off-farm activities.

In Ghana, national climate change adaptation strategy has been developed and various adaptation programs and strategies have been outlined to combat climate change. Some of these strategies include: (i) increasing resilience to climate change impacts: identifying and enhancing early warning systems, and (ii) alternative livelihoods: minimizing impacts of climate change for the poor and vulnerable needs to be implemented at the study catchment to help reduce the vulnerability of the people to future climate change and extremes. Other adaptation strategies recommended for the Veia catchment include:

1. Implementation of water use efficiency system as part of effective management of water resources at the catchment. Due to the projected increased in temperature and the variability in rainfall, water use efficiency system such as drip irrigation needs to be promoted to ensure not only all year-round farming but also reduce demands from the three main water sectors: domestic supply, agriculture, and industry.
2. Enhance local capacity to adapt to climate change through improved land use management and agricultural diversification.
3. Awareness creation on the need to protect and effectively manage the Vea dam and streams within the Vea catchment through the creation of vegetation buffers to protect the water resources.
4. Developing early warning systems and farmers access to climate information so as to adequately inform policy makers and enhance farmers' resilience to extreme events as a result of climate change.

---

## Conclusions

The changes in future climate and extremes indices in the Vea catchment was computed from the Expert Team on Climate Change Detection Monitoring Indices based on the observed climate and multi-model mean of four bias-corrected RCMs. The climate simulation under RCP4.5 scenario for the catchment show a warmer climate with 1.3 °C temperature increase in 2020–2049. The trend analysis of the rainfall and temperature extremes indices indicated a continuous extreme temperature rise as well as an increase in intensity of extreme rainfall events in 2020–2049 at the catchment. The projected increase in extreme temperature (TXx and TNx), intensity (R99p), and frequency (CDD) of extreme rainfall indicate the catchment vulnerability to the risk of climate disasters, hence the need for decision-makers to adapt and mitigate climate change over the area. The study also provided evidence that the daily maximum temperature (warmest day) would increase at a faster rate compared to the daily minimum temperature (warmest night), indicating more warming in the day compared to the night. Encouraging adaptation policies such as rainwater harvesting, availability climate information, flood control measures, and the development of early warning systems are necessary at the Vea catchment to mitigate the effects of future extreme climate events.

---

## References

- Abeygunawardena P, Vyas Y, Knill P, Foy T, Harrold M, Steele P, Sperling F (2003) Part 1. Poverty and climate change: reducing the vulnerability of the poor through adaptation. World Bank, Washington, DC. Accessed 28 Aug 2019. <http://agris.fao.org/agris-search/search.do?recordID=US2012416506>
- Adeyeri OE, Lawin AE, Laux P, Ishola KA, Ige SO (2019) Analysis of climate extreme indices over the Komadugu-Yobe basin, Lake Chad region: past and future occurrences. *Clim Extrem* 29:21–39

- Alexander LV, Zhang X, Peterson TC, Caesar J, Gleason B, Klein Tank AMG, Vazquez-Aguirre JL (2006) Global observed changes in daily climate extremes of temperature and precipitation. *J Geophys Res Atmos* 111:D05109. <https://doi.org/10.1029/2005JD006290>
- Amuzu J, Kabo-Bah AT, Jallow BP, Yaffa S (2018) Households' livelihood vulnerability to climate change and climate variability. A case study of the coastal zone, the Gambia. *J Environ Earth Sci* 8:35–46. <https://doi.org/10.13140/RG.2.2.36057.42081>
- Apata TG (2011) Factors influencing the perception and choice of adaptation measures to climate change among farmers in Nigeria. Evidence from farm households in Southwest Nigeria. *Environ Econ* 2(4):74–83
- Awotwi A, Kumi M, Jansson PE, Yeboah F, Nti IK (2015) Predicting hydrological response to climate change in the White Volta Catchment, West Africa. *J Earth Sci Clim Change* 6:249. <https://doi.org/10.4172/2157-7617.1000249>
- Bessah E, Raji AO, Taiwo OJ, Agodzo SK, Olofade OO (2018) Variable resolution modeling of near future mean temperature changes in the dry sub-humid region of Ghana. *Modeling Earth Systems and Environment* 4(3):919–933. <https://doi.org/10.1007/s40808-018-0479-0>
- Bohle HG, Downing TE, Watts MJ (2018) Climate change and social vulnerability toward a sociology and geography of food insecurity. *Glob Environ Change* 4:37–48. [https://doi.org/10.1016/0959-3780\(94\)90020-5](https://doi.org/10.1016/0959-3780(94)90020-5)
- Chen H, Chong-Yu X, Guo S (2012) Comparison and evaluation of multiple GCMs, statistical downscaling and hydrological models in the study of climate change impacts on runoff. *J Hydrol* 434–435:36–45
- De Pinto A, Demirag U, Haruna A, Koo J, Asamoah M (2012) Climate change, agriculture, and food-crop production in Ghana. International Food Policy 213 Research Institute Policy note #3: Ghana Strategy Support Program, International Food Policy Research Institute. Available: <http://www.ifpri.org/sites/default/files/publications/gssppn3.pdf>. Accessed 20 Sept 2014
- Environmental Protection Agency (2007) Climate change and the Ghanaian economy. In: Policy advice series, vol 1. Environmental Protection Agency of Ghana, Accra
- FAO (2013) The State of Food Insecurity in the World 2013. The multiple dimensions of food security. FAO, Rome. ISBN 978-92-5-107916-4
- Feng-Wen C, Chen-Wuing L (2012) Estimation of the spatial rainfall distribution using inverse distance weighting (IDW) in the middle of Taiwan. *Paddy Water Environ* 10:209–222. <https://doi.org/10.1007/s10333-012-0319-1>
- Forkuor G (2014) Agricultural land use mapping in West Africa using multi-sensor satellite imagery. PhD dissertation, Julius-Maximilians-Universität Würzburg
- Fosu-Mensah BY, Vlek PLG, MacCarthy DS (2012) Farmers' perception and adaptation to climate change: a case study of Sekyedumase district in Ghana. *Environ Dev Sustain* 14:495–505
- Funk C, Peterson P, Landsfeld M, Pedreros D, Verdin J, Shukla S, ... Michaelsen J (2015) The climate hazards infrared precipitation with stations – a new environmental record for monitoring extremes. *Sci Data* 2:150066. <https://doi.org/10.1038/sdata.2015.66>
- Gobiet A, Kotlarski S, Beniston M, Heinrich G, Rajczak J, Stoffel M (2014) 21st century climate change in the European Alps – a review. *Sci Total Environ* 493:1138–1151
- Gyasi EA, Karikari O, Kranjac-Berisavljevic G, Vordzogbe V (2006) Climate change vulnerability and adaptation assessment relative to land management in Ghana. Reports of the Members of the Study Team, Accra
- Heinzeller D, Olusegun C, Kunstmann H (2016) Projected future (2070–2099): High Resolution (12km) WRF-MPI Daily Near-Surface Relative Humidity over West Africa, (WASCAL Project). <https://wascal-dataportal.org/geonetwork/?uuid=0cafe3f0-adf5-43d7-9483-6fbd2b05d86d>
- Heinzeller D, Dieng D, Smiatek G, Olusegun C, Klein C, Hamann I, Salack S, Kunstmann H (2017) The WASCAL high-resolution regional climate simulation ensemble for West Africa: concept, dissemination, assessment. *Earth Syst Sci Data Discuss*. <https://doi.org/10.5194/essd-2017-93>
- Kanlisi KS, Arkum TA (2013) Builsa community vulnerability and capacity assessment in the Upper East Region of Ghana. *Eur Sci J Ed* 9(29):144–164. e-ISSN: 1857–7431
- Kim J, Waliser DE, Mattmann CA, Goodale CE, Hart AF, Zimdars PA, Daniel J (2013) Evaluation of the CORDEX-Africa multi-RCM hindcast: systematic model errors. *Clim Dyn* 42(5–6):1189–1202. <https://doi.org/10.1007/s00382-013-1751-7>

- Kumasi TC, Antwi-Agyei P, Obiri-Danso K (2017) Small-holder farmers' climate change adaptation practices in the Upper East Region of Ghana. *Environ Dev Sustain*. <https://doi.org/10.1007/s10668-017-0062-2>
- Larbi I, Hountondji FCC, Annor T, Agyare WA, Gathenya JM, Amuzu J (2018) Spatio-temporal trend analysis of rainfall and temperature extremes in the Veua catchment. *Climate* 6(87):1–17. <https://doi.org/10.3390/cli6040087>
- Larbi I, Hountondji FCC, Mama D, Nyamekye C, Adeyeri OE, Koubodana DH, Odoom PRE, Asare YM (2020) Local Climate change projections and impact on the surface hydrology in the Veua catchment, West Africa. *Hydrology Research*, In press. <https://doi.org/10.2268/nh.2020.022>
- Lawson E T, Alare RS, Salifu ARZ, Thompson-Hall M (2019). Dealing with climate change in semi-arid Ghana: understanding intersectional perceptions and adaptation strategies of women farmers. *GeoJournal*. <https://doi.org/10.1007/s10708-019-09974-4>
- Limantol AM, Keith BE, Azabre BA, Lennartz B (2016) Farmers' perception and adaptation practice to climate variability and change: a case study of the Veua catchment in Ghana. *Springerplus* 5:830. <https://doi.org/10.1186/s40064-016-2433-9>
- M'Po YN, Lawin EA, Yao BK, Oyerinde GT, Attogouinon A, Afouda AA (2017) Decreasing past and mid-century rainfall indices over the Ouémé River Basin, Benin (West Africa). *Climate* 5:74. <https://doi.org/10.3390/cli5030074>
- Maraun D, Wetterhall F, Ireson AM, Chandler RE, Kendon EJ, Widmann M, . . . Thiele-Eich I (2010) Precipitation downscaling under climate change: recent developments to bridge the gap between dynamical models and the end user. *Rev Geophys* 48:RG3003. <https://doi.org/10.1029/2009RG000314>
- McSweeney C, New M, Lizcano G (2010a) UNDP climate change country profiles: Ghana. Available: <http://country-profiles.geog.ox.ac.uk>. Accessed 24 Feb 2018
- McSweeney C, New M, Lizcano G, Lu X (2010b) The UNDP climate change country profiles. *Am Meteorol Soc* 91:157–166
- Ministry of Environment Science, Technology and Innovation (2013) Ghana national climate change policy. Ministry of Environment Science, Technology and Innovation, Accra
- Minville M, Brissette F, Krau S, Leconte R (2009) Adaptation to climate change in the management of a Canadian water-resources system exploited for hydropower. *Water Resour Manag* 23:2965–2986
- Mouhamed L, Traore SB, Alhassane A, Sarr B (2013) Evolution of some observed climate extremes in the West African Sahel. *Weather Clim Extrem* 1:19–25
- New M, Hewitson B, Stephenson DB, Tsiga A, Kruger A, Manhique A, . . . Lajoie R (2006) Evidence of trends in daily climate extremes over southern and West Africa. *J Geophys Res* 111: D14102. <https://doi.org/10.1029/2005JD006289>
- Obuobie E (2008) Estimation of groundwater recharge in the context of future climate change in the White Volta River Basin. PhD dissertation, Rheinische Friedrich Wilhelms Universität, Bonn
- Ofori-Sarpong E (2001) Impact of climate change on agriculture and farmers coping strategies in the Upper East Region of Ghana. *West Afr J Appl Ecol* 2:21–35
- Ogountundé PG, Friesen J, van de Giesen N, Savenije HHG (2006) Hydroclimatology of the Volta River Basin in West Africa: trends and variability from 1901 to 2002. *Phys Chem Earth* 31:1180–1188
- Panday PK, Thibeault J, Freyc KE (2015) Changing temperature and precipitation extremes in the Hindu Kush-Himalayan region: an analysis of CMIP3 and CMIP5 simulations and projections. *Int J Climatol* 35:3058–3077. <https://doi.org/10.1002/joc.4192>
- Sarr B (2012) Present and future climate change in the semi-arid region of West Africa. A crucial input for practical adaptation in agriculture. *Atmos Sci Lett* 13:108–112. <https://doi.org/10.1002/asl.368>
- Seager R, Vecchi GA (2010) Greenhouse warming and the 21st century hydroclimate of south-western North America. *Proc Natl Acad Sci* 107(50):21277–21282
- Soro GE, Noufé D, Goula Bi TA, Shorohou B (2016) Trend analysis for extreme rainfall at sub-daily and daily timescales in Côte d'Ivoire. *Climate* 4:37

- Sylla MB, Diallo I, Pal JS (2013) West African monsoon in state-of-the-science regional climate models. In: Climate variability-regional and thematic patterns. IntechOpen. <https://doi.org/10.5772/55140>
- Tomassini L, Jacob D (2009) Spatial analysis of trends in extreme precipitation events in high-resolution climate model results and observations for Germany. *J Geophys Res* 114:D12113
- Trenberth KE, Jones PD, Ambenje P, Bojariu R, ... Rusticucci M (2007) Observations: surface and atmospheric climate change, Chapter 3. In: Solomon S, Qin D, Manning M, Marquis M, Averyt KB, Tignor M, Miller HL, Chen Z (eds) *Climate Change 2007: the physical science basis. Contribution of Working Group I to the Fourth Assessment Report of the Intergovernmental Panel on Climate Change*. Cambridge University Press, Cambridge, UK/New York, pp 235–336
- World Bank (2010) *Economics of adaptation to climate change: synthesis report*. The International Bank for Reconstruction and Development/World Bank, Washington, DC. Available: [https://openknowledge.worldbank.org/bitstream/handle/10986/12750/702670ESW0P10800EACC\\_SynthesisReport.pdf?sequence=1](https://openknowledge.worldbank.org/bitstream/handle/10986/12750/702670ESW0P10800EACC_SynthesisReport.pdf?sequence=1). Accessed 26 Feb 2018
- Xu CY (1999) From GCMs to river flow: a review of downscaling methods and hydrologic modeling approaches. *Progr Phys Geogr* 23(2), 229–249. 107, 21277–21282. <https://doi.org/10.1073/pnas.0910856107>
- Zhang S, Lu XX, Higgitt DL, Chen CTA, Han J (2008) Recent changes of water discharge and sediment load in the Zhujiang (Pearl River) Basin, China. *Glob Planet Chang* 60:365–380

**Open Access** This chapter is licensed under the terms of the Creative Commons Attribution 4.0 International License (<http://creativecommons.org/licenses/by/4.0/>), which permits use, sharing, adaptation, distribution and reproduction in any medium or format, as long as you give appropriate credit to the original author(s) and the source, provide a link to the Creative Commons license and indicate if changes were made.

The images or other third party material in this chapter are included in the chapter's Creative Commons license, unless indicated otherwise in a credit line to the material. If material is not included in the chapter's Creative Commons license and your intended use is not permitted by statutory regulation or exceeds the permitted use, you will need to obtain permission directly from the copyright holder.





# Climate Change Resistant Energy Sources for Global Adaptation

# 96

Oluwatobi Ololade Ife-Adediran and Oluyemi Bright Aboyewa

## Contents

Introduction .....	1956
Vulnerability Assessment of Various Energy Systems .....	1958
Hydropower .....	1958
Solar Energy .....	1960
Wind .....	1961
Biofuel .....	1961
Oil and Natural Gas .....	1962
Thermal Power Plant .....	1962
Conclusion .....	1963
References .....	1964

## Abstract

A holistic response and adaptation to climatic vicissitudes and extreme conditions as well as their associated risks to human and ecological sustainability must adequately cater for energy needs and optimization. An interventional approach should, among other measures, seek to improve the resilience of existing and prospective energy systems to climate change. The structured and policy-driven

This chapter was previously published non-open access with exclusive rights reserved by the Publisher. It has been changed retrospectively to open access under a CC BY 4.0 license and the copyright holder is “The Author(s)”. For further details, please see the license information at the end of the chapter.

O. O. Ife-Adediran (✉)

Geochronology Division, CSIR-National Geophysical Research Institute (NGRI),  
Hyderabad, India

Department of Physics, Federal University of Technology Akure, Akure, Ondo State, Nigeria  
e-mail: [tobireliable@yahoo.com](mailto:tobireliable@yahoo.com)

O. B. Aboyewa

Department of Physics, College of Arts and Sciences, Creighton University, Omaha, NE, USA

© The Author(s) 2021

W. Leal Filho et al. (eds.), *African Handbook of Climate Change Adaptation*,  
[https://doi.org/10.1007/978-3-030-45106-6\\_106](https://doi.org/10.1007/978-3-030-45106-6_106)

1955

nature of adaptation measures require a bottom-up proactive approach that envisages the performance and efficiency of these systems, especially in terms of their sensitivity and vulnerability to changing climate conditions. Therefore, this chapter seeks to scrutinize various sources of energy concerning their resistance capabilities to climate change in the face of increasing global energy demands and consumption. Renewable and conventional energy sources are co-examined and compared vis-à-vis the current trends and predictions on climatic factors that are bearing on their principles of production, supply, and distribution. Findings from this chapter will serve as assessment tools for decision makers and corroborate other ongoing discourse on climate actions towards socioeconomic development and a sustainable environment.

---

**Keywords**

Climate change · Extreme conditions · Energy resources · Sustainability · optimization

---

**Introduction**

Energy represents a fundamental requirement for wealth and job creation in many parts of the world. For many decades, humans have leveraged on the conversion of chemical energy in fossil fuels to other forms of energy. Unfortunately, these energy conversions are accompanied by the release of gases into the atmosphere and this has gradually engendered climate change; hence, the recent emphasis on energy policy alterations that factor sustainable energy supply and environment (Bang 2010). On a global scale, climate change poses increasingly severe risks on the ecosystem; the effect is particularly telling on human health, environmental safety, agriculture and economy. These changes are mostly as a result of the release of large amounts of greenhouse gases (GHG) into the atmosphere. These gases result from anthropological activities all over the world, such as burning fossil fuels for electricity and heat generation, as well as the use of internal combustion engines for transportation (EEA 2017). According to the 2019 report of the International Renewable Energy Agency (IRENA), despite the actions towards global energy transformation, carbon dioxide (CO<sub>2</sub>) emissions that are related to the energy sector, have increased annually by over 1% on average from 2013 and 2018 (IRENA 2019). The European Environment Agency also submits that the energy sector, especially in relation to utilization of fossil fuels, lies at the heart of the challenges that are associated with climate change (EEA 2017). In fact, the utilization of energy by humans constitutes the largest contribution to the emission of greenhouse gases. The Energy Sector Management Assistance Program (ESMAP) presents the urgency of actions to control emissions and the necessity to adapt to unavoidable climate effects from the damage already induced in the biosphere due to anthropogenic GHG emissions. Energy generation and utilization do not only contribute to climate change due to greenhouse gas (GHG) emissions but are also directly influenced by its adverse effects (EUEIPDF 2017).

Environmental concerns will largely influence the generation, supply and utilization of energy in the near future; hence, the interest in alternative fuels and improvement in energy conversion technologies (Bauen 2006). In a broad sense, climate change affects energy supply and demand in terms of endowment, exploitation infrastructure and transportation. The effect of climate change on energy security ripples to other sectors such as socioeconomy, industry, and biodiversity (Ebinger and Vergara 2011). More specifically, in 2005, climate change resulted to over 10% variation in energy yield in developing countries (World Bank 2009). Changes in climatic parameters are evidential and can be observed in the lower atmospheric conditions, sea level and surface temperatures as well as topsoil wetness or dryness (Ebinger and Vergara 2011). Some predictions by the Intergovernmental Panel on Climate Change (IPCC) include an increase in global average temperature by close to 5 °C by the end of the century, fluctuating precipitation patterns and intensity, recurring extreme weather events and sea-level expansion (EUEIPDF 2017). Changes in ambient air temperature will affect the energy required for heating and cooling applications. Storms are notable for the destruction of electricity distribution infrastructure and this is being mitigated through underground cable networks. In relation to overcoming the adverse effects of climate change on clean energy generation, Bauen (2006) opined that there is great need for ingenuity, research, investment, and regulations.

Among other merits, renewable energy plays a crucial role in future low-carbon-emission plans aimed at mitigating global warming. When combined with improved energy efficiency, renewable energy is capable of achieving a 75% reduction in energy-related CO<sub>2</sub> emission (IRENA 2019). Bhuiyan et al. (2018) suggested that conservation of biodiversity and environmental sustainability require the exploitation of different renewable energy sources. However, the dependence of renewal energy exploration on and climatic conditions and susceptibility to climate change is a significant area of concern (Ebinger and Vergara 2011). This is in addition to their relatively high cost of generating electricity and uneven natural distribution cum availability. In principle, the adaptation of energy systems is primarily aimed at sustainable energy supply as well as balance between energy production and consumption under varying temporal and spatial conditions (IPCC 2007). However, in reality, climate variability and extremes represent the most significant threat to the entire energy supply chain. Some future projections reveal that the energy sector will become increasingly susceptible to climate change; hence, the need for effective adaptive measures (Ebinger and Vergara 2011).

Energy adaptation in the face of climate change requires reliable and sufficient weather and meteorological data, forecast models and modalities for the performance evaluation assessment of energy systems (Troccoli 2009). Climate change impacts are envisaged throughout the energy system; affecting both demand and supply. There are associated changes in demand patterns for heating and cooling due to rising temperatures. On the supply end, impacts include changes in wind direction and intensity, solar and hydropower resources, the available crops as raw materials for biomass energy production, costs and accessibility of fossil fuels in the face of frozen sea water and permafrost, the efficiency of Photovoltaic systems, thermoelectric power plants and cable systems due to increasing temperatures, as well as



operational downtime due to the occurrence of extreme weather events (Cronin et al. 2018). In low income countries, energy supplies are unstable as a result of the relatively high dependence on hydroelectricity and biomass energy which are contingent on rainfall patterns and intensity (Ebinger and Vergara 2011).

Although there is an increased focus on investigating the impact of climate change on energy systems, the formal knowledge base appears to be limited (Wilbanks et al. 2007; Schaeffer et al. 2012). More importantly, studies are based on scenario analysis rather than predictions and are hindered by inherent uncertainties in modeling tools (Schaeffer et al. 2012). There are significant uncertainties that are associated with future climate projections and its effect on energy systems (Schaeffer et al. 2012). This chapter seeks to scrutinize various energy sources, especially concerning their resistance capabilities to climate change using existing research database on global and regional predictions on the vulnerability assessment of energy systems. Renewable (hydropower, wind, solar energy, biofuel etc.) and fossil energy (oil and natural gas) sources are co-examined and compared vis-à-vis the current trends and predictions on climatic factors that are bearing on their principles of production, supply and distribution.

---

## Vulnerability Assessment of Various Energy Systems

### Hydropower

Hydropower contributes significantly to total and per capita energy supply in many countries as a prominent renewable and primary energy source of electricity. The main requirement for the production of hydropower is runoff, which is largely dependent on rainfall (Hamududu and Killingtveit 2012). In view of the absolute dependence of hydropower on water resources, countries that depend largely on this source of energy experience a seasonal variation in the production of electricity (Teotónio et al. 2017; Rübhelke and Vögele 2012). Climate variability will definitely affect precipitation rate and regularity (Costa et al. 2012; Turner et al. 2017), which in turn affects hydroelectric power generation through changes in river flow, water storage, and downstream energy production (Tapiador et al. 2011; Teotónio et al. 2017). Apart from the direct effects, climate change can indirectly affect hydropower generation as a result of competitive demands and pressure on water resources by non-energy based economic sectors such as agriculture. Climate change can also engender contentions regarding water resource allocation and utilization between countries that jointly possess river catchments (Teotónio et al. 2017). Water reservoirs enhance the management of transient flow events and changes in river flow intensities (Lehner et al. 2005; Gaudard and Romerio 2014; Teotónio et al. 2017). Inter-seasonal water storages can also be adapted as resilience measures against the effect of climate change on hydropower. The effect of climate change on hydropower depends on the depths and surface areas of dams. The evaporation potential of shallow and wide dams makes them vulnerable to climate change as a result of the heat associated with global warming and the consequent increase in evaporation and drought intensity (Mukheibir 2013; Trenberth 2011; Teotónio et al. 2017).

Studies related to climate change impacts on hydropower can be done using different methods, with data that are assessed globally, regionally, or locally. Predictive impact assessments can also be carried out using modeling techniques. Although large scale analyses demonstrate inherent uncertainties based on modeling choices, they, however, provide tools for assessing global vulnerability hotspots. More impressive accuracies are achieved with models that are developed using data obtained from regions with similar climatic conditions (Turner et al. 2017). Some studies and projections found in literatures are reported as follows; Hamududu and Killingtveit (2012) used a group of simulated regional patterns of variations in runoff, which were generated from global circulation models (GCM), to estimate changes in global hydropower generation resulting from predicted changes in climate. The evaluation showed that significant impacts of climate change on hydropower generation, especially from existing power systems, is more probable on a country or regional level than a global scale. On the contrary, a recent study by van Vliet et al. (2015), using an integrated modeling and data framework on existing hydropower power plants, forecasted a decrease in usable output for more than half of the hydropower plants worldwide for a period of thirty (30) years starting from 2040. Unlike previous studies that adopted the coupled hydrological electricity modeling method on a small scale, van Vliet et al. (2015) utilized this model to establish the effect of climate change and varying water resources on global electricity supply in the twenty-first century. It is apparent that results of localized predictions of the effect of climate change on the generation of hydropower should be carefully interpreted and cannot be generalized. Furthermore, the generalization of parameters that have high spatial variation should be avoided (Schaeffli 2015; Turner et al. 2017).

Turner et al. (2017) identified regions with projected significant losses in hydropower production using a coupled, global hydrological and dam operating model with three GCM projections for two emissions frameworks. The global vulnerability hotspots that were identified include; the countries of southern Europe that surround the Mediterranean Sea, as well as those within North Africa and the Middle East region. In a local study, Teotónio et al. (2017) employed an optimization model to predict the impact of climate variation on the availability of water resources and the electrical power generation in Portugal. Findings from the study showed that by 2050, hydropower generation may fall significantly and lead to higher costs of electricity in the study location as a result of climate. This result is corroborated by a similar analysis carried out by Carvajal et al. (2017) in Ecuador, which revealed that hydropower generation is relatively unstable and vulnerable to climate change since variations in throughput to hydropower stations would result in changes in the expected hydropower generation, given stable conditions.

While hydropower exploitation contributes to low carbon development initiatives, reduction in plant output due to drying climate conditions engenders the dependence on fossil fuels especially when other renewable energy sources are not competitive (Spalding-Fecher et al. 2017). The resistance of hydropower plants to climate change and its consequent effect on availability of freshwater resources can be enhanced through improvements in plant efficiency, cooling systems and fuel switches (van Vliet et al. 2015). Recently, the International Hydropower Association

(IHA), presented a six-phase approach to climate resilience for the hydropower sector which includes; comprehending what climate resilience means for the sector, a first phase of qualitative assessment of the project to climate risks, an initial or preliminary analysis, a climate stress test, risk management planning, and lastly the monitoring, evaluation and reporting of the outcomes of each of the phases (IHA 2019).

## Solar Energy

Solar power ranks as the third most utilized renewable energy (after hydropower and biomass energy) and constitutes an increasingly essential component of the future low carbon-energy campaign across the globe (Panagea et al. 2014). Solar energy is mostly harnessed for both heating and electricity generation through active or passive energy systems which utilize solar collectors, photovoltaics, power towers, solar ponds, or ocean thermal collection. Through the Photoelectric effect, solar cells are utilized in the direct conversion of solar radiation to electricity; conversion efficiencies above 20% can be achieved through technologies that concentrate the incident light rays (Patt et al. 2013). The efficiency of Photovoltaic (PV) systems can be primarily influenced by geometry, ageing, ambient conditions, environmental pollution, as well as electrical, visual, and shade losses (Skoplaki and Palyvos 2009; Mani and Pillai 2010; Meral and Diner 2011; Panagea et al. 2014). The output of PV cells has a nearly linear inverse relationship with cell temperature and a directly proportional response total irradiance. Hailstorms can also affect the performance and most notably, the physical components of PV systems (the PV modules). Some of the existing solar energy technologies such as pump or circulation systems are used in environments with extreme freezing or overheating temperatures.

The impact of climate change on temperature and irradiance will significantly affect PV output (Crook et al. 2011). Climate change effects have a bearing on atmospheric transmissivity by changing atmospheric water vapor content, cloudiness (Cutforth and Judiesch 2007), and its aerosols content (Gaetani et al. 2014). Generally, the efficiency of PV modules drops by about 0.5% per degree Celsius rise in temperature (Patt et al. 2013). A study by Crook et al. (2011) utilized data obtained from coupled ocean-atmosphere climate models to indicate that PV output from 2010 to 2080 will change slightly in Algeria and Australia while it will probably rise or reduce in some parts of North America, Europe, and Asia. In another study conducted by Gaetani et al. (2014) using climate-aerosol modeling experiments, the results showed that by 2030, there will be varied effects of climate change on the production of photovoltaic energy in different parts of the world; this result is consistent with that of Crook et al. (2011). In Greece, there is an inverse relationship between the output of PV devices and the predicted rise in annual temperature, which is exceeded by the projected increase of total radiation resulting in a net increase in energy output (Panagea et al. 2014). Further location-specific studies are required for quantitative assessments of climate impacts on PV systems (Patt et al. 2013).

## Wind

Wind energy is well explored for electricity generation, but it is not insulated from the influence of climatic vicissitudes since its energy density depends on global energy balance and the consequent atmospheric motion (Pryor and Barthelmie 2010; Schaeffer et al. 2012). The energy output from wind has a cubic relationship with the speed of the moving air mass, and it is proportional to air density (Manwell et al. 2002; Pryor and Barthelmie 2010). A differential change in wind speed will affect its potential for electricity production, timing, and the operational period of wind plant (Pasicko et al. 2012). According to Baker et al. (1990), a 10% change in the average wind speed could alter energy production by up to one-quarter of its initial capacity. Hence increase in wind speeds as a result of climate change should result in increased energy outputs and this could translate to an increased dependence on this energy source. Wind turbines are carefully structured to factor transient wind conditions such as the occurrence of extreme wind speeds, and other aerodynamics such as directional variations (DNV 2002). The reliability and safety of a wind power plant is determined by the maximum wind speed for which it is designed (Pasicko et al. 2012). Wind turbines should be kept nonoperational during conditions that exceed their reliability and safety indexes in order to avoid infrastructural damages.

Wind speed varies significantly with elevation from sea level as well as the spatial density of natural and artificial wind breakers (Ebinger and Vergara 2011). Several other variables can impact the vertical profile of a moving air mass, and the extrapolation of wind speeds at heights where they are not measured is quite convoluted. The logarithmic extrapolation method is popularly adopted in the estimation of wind speeds at hub heights of wind turbines that are above 50 m (Schaeffer et al. 2012). The consideration of the terrain roughness is characteristic of this method of estimation. With regards to wind energy, the roughness of a terrain is dependent on vegetative cover which can be significantly affected by climate changes and consequently impact the generation of wind power (Lucena et al. 2010; Schaeffer et al. 2012). As such, the development of wind energy production requires reliable information about the potential variations in wind energy availability as well as topographical parameters in a location of interest (Bloom et al. 2008).

## Biofuel

Bioenergy (which is generated from crops such as jatropha, sunflower, cotton, sugarcane, sorghum, and maize) is a vast and diverse energy source category since it consists of a wide range of organic fuels that can be adapted to various types of technologies to run engines, produce heat or generate electricity (Kirsten 2012). Perennials with suitable land cover are preferable as energy crops. Oilseeds are particularly used as pure plant oil and for biodiesel production while sugarcane and cereals are used in some parts of the world for the production of bioethanol as alternatives to gasoline for engines such as automobiles (Kirsten 2012), thereby

portending significant contribution to the reduction of carbon footprint from transportation. The sustainability of biodiesel remains a debate as most studies come to a wide range of conclusions due to differences in approach, biomass input sources, land use and its associated change impacts, choice of system limits and functional units, as well as the methods that are adopted for allocation (Rouhany and Montgomery 2019). However, it is apparent that climate change has its toll on bioenergy production. For instance, liquid biofuels are indirectly susceptible to changes in temperature and rainfall patterns, as well as available CO<sub>2</sub> to crops which serve as feedstock for the production of transportation biofuels (Schaeffer et al. 2012). Average crop yields and arable land suitable for growing bioenergy crops are affected by rising temperatures and changing precipitation patterns (EUEIPDF 2017; Cronin et al. 2018). Some specific resulting adverse effects in this regard are land-area losses due to flood, salinity and dry-out influences of increased temperature (Mohammad 2013). For plants, CO<sub>2</sub> is an essential greenhouse gas because of its necessity for photosynthetic process. Haberl et al. (2011) explicitly examined mean cropland yield change under climate change in 2050 with and without CO<sub>2</sub> fertilization, and the findings indicated regional variation and increase as high as 28.22% in crop yield with full CO<sub>2</sub> fertilization and considerable loss (up to -16.02%) when this effect is controlled.

## Oil and Natural Gas

The primary concerns regarding the utilization of fossil fuels are related to their depletion, future exhaustion, and carbon emission. Oil and gas conventional energy deposits are not likely to be affected by climate change due to their long-term formation process in geological traps (Ebinger and Vergara 2011). However, there could be indirect effects on the utilization of these resources especially with regards to the identification of natural reserves and accessibility to them (Schaeffer et al. 2012). Climate change events can affect oil and gas exploration, processing and transportation (Burkett 2011). Hurricanes and other extreme climatic events can hamper the production of these fossil fuels from off-shore facilities (Ebinger and Vergara 2011). Similarly, Burkett (2011) identifies that changes in climate variables such as sea and CO<sub>2</sub> levels, intensity of storms, wave regime, air and water temperature, rainfall patterns and ocean acidity also can affect oil and gas exploration in coastal regions (Schaeffer et al. 2012). There are also predictions that significant reduction in ice cover may increase the feasibility of exploration in areas of the Arctic (Harsem et al. 2011; Ebinger and Vergara 2011; Schaeffer et al. 2012), raising the prospect for oil and gas development in this region.

## Thermal Power Plant

The impacts of climate change on thermal power plants are mainly related to generation cycle efficiency and water needed for cooling of power plants (Wilbanks et al. 2007; Ebinger and Vergara 2011). Some technologies that could

be affected in this regard include coal, biomass residue, and geothermal power plants (Schaeffer et al. 2012). Generally, thermal plants operate with Rankine or Brayton thermodynamic cycles, require energy for heating and cooling processes, which depend on average ambient atmospheric conditions (Schaeffer et al. 2012). Increase in temperature is likely to reduce the thermal efficiency and output of power plant (Ibrahim et al. 2014; Linnerud et al. 2011; Cronin et al. 2018). Also, expected changes in water resource availability throughout the globe will have a direct influence on the use of water for cooling existing power plants and consequently, their output capacity (Wilbanks et al. 2007). Furthermore, reduction in water resources that is available for cooling may result to load-shedding or shutdown of power stations (Cronin et al. 2018). It has been projected that by 2040 capacity reductions of 12–19% in Europe and the US are possible due to rise in water temperatures and reduction in runoff (van Vliet et al. 2012; Sieber 2013). Generally, while it is expected that changes on power plants capacity will vary according to regions (for example, increase in India and Russia); generally, global annual thermal plant capacity is likely to shrink by 7–12% in the mid-century (van Vliet et al. 2015).

---

## Conclusion

The global concern on climate change, extreme conditions and their associated footprints are in increasingly alarming degrees, especially in recent times. In spite of the preventive and adaptive measures that have been applied at local and international fronts, it is vivid that remedial actions must be taken to supplement the efforts against the adverse effects of climate change and this study shows that the energy sector is not left out of the need for intervention. The interaction between climate change and energy adaption is significant and should be taken seriously. This chapter makes a case of climate change-resistant energy utilization by examining the resilience of different energy sources to climate change, through a retrospective consideration of relevant findings from literatures on energy resources, needs and utilization as well as climatic factors, their current trends and future prediction. Consequently, it explicates the dire need for adaptive measures towards energy utilization in the face of climate changes and severe conditions. Climate change has direct and indirect effects on the exploitation of conventional and non-conventional energy resources. The effect of climate change on water resources and temperature seems to have the most significant effect on different energy sources and technologies. Extreme weather events such as hurricanes and hailstorms are detrimental to the energy systems with relatively fragile structures especially for renewable energy exploitation. This study reveals that there are temporal variations in the effect of climate change on energy systems in different parts of the world. Hence, local conditions must be considered in decision-making with regards to climate change and energy. It is hoped that this discussion provides an adequate injection of pooled examinations of different energy sources towards the sustainability and optimization of their utilization in response to climate change.

## References

- Mohammad Ali (2013) Climate change impacts on plant biomass growth. Springer, Dordrecht/Heidelberg/New York, pp 29–41
- Baker RW, Walker SN, Wade JE (1990) Annual and seasonal variations in mean wind speed and wind turbine energy production. *Sol Energy* 45(5):285–289
- Bang G (2010) Energy security and climate change concerns: triggers for energy policy change in the United States? *Energy Policy* 38:1645–1653
- Bauen A (2006) Future energy sources and systems – acting on climate change and energy security. *J Power Sources* 157:893–901
- Bhuiyan AM, Jabeen M, Zaman K, Khan A, Ahmad J, Hishan SS (2018) The impact of climate change and energy resources on biodiversity loss: evidence from a panel of selected Asian countries. *Renew Energy* 117:324–340
- Bloom A, Kotroni V, Lagouvardos K (2008) Climate change impact of wind energy availability in the Eastern Mediterranean using the regional climate model PRECIS. *Nat Hazards Earth Syst Sci* 8:1249–1257
- Burkett V (2011) Global climate change implications for coastal and offshore oil and gas development. *Energy Policy* 39:7719–7725
- Carvajal PE et al (2017) Assessing uncertainty of climate change impacts on long-term hydropower generation using the CMIP5 ensemble – the case of Ecuador. *Climate Change* 144(4):611–624
- Costa AC, Santos JA, Pinto JG (2012) Climate change scenarios for precipitation extremes in Portugal. *Theor Appl Climatol* 10:217–234
- Cronin J, Anandarajah G, Dessens O (2018) Climate change impacts on the energy system: a review of trends and gaps. *Clim Chang* 151:79–93
- Crook JA, Jones LA, Forstera PM, Crook R (2011) Climate change impacts on future photovoltaic and concentrated solar power energy output. *Energy Environ Sci* 4:3101–3109
- Cutforth HW, Judiesch D (2007) Long-term changes to incoming solar energy on the Canadian prairie. *Agric For Meteorol* 145:167–175
- DNV/Riso (2002) Guidelines for the design of wind turbines, 2nd edn. Jydsk cetrallykkeri, Copenhagen. 286 pp
- Ebinger J, Vergara W (2011) Climate impacts on energy systems: key issues for energy sector adaptation. World Bank, Washington, DC, pp 26–51
- EU EIPDF – EU Energy Initiative Partnership Dialogue Facility (2017) Energy and climate change adaptation in developing countries. European Union Energy Initiative Partnership Dialogue Facility, Eschborn, pp 6–12
- European Environment Agency – EEA (2017) Energy and climate change. European Environment Information and Observation Network (Eionet), Copenhagen, pp 1–10
- Gaetani M, Huld T, Vignati E, Monforti-Ferrario F, Dosio A, Raes F (2014) The near future availability of photovoltaic energy in Europe and Africa in climate-aerosol modelling experiments. *Renew Sust Energ Rev* 38:706–771
- Gaudard L, Romerio F (2014) The future of hydropower in Europe: interconnecting climate, markets and policies. *Environ Sci Policy* 43:5–14
- Haberl H et al (2011) Global bioenergy potentials from agricultural land in 2050: sensitivity to climate change, diets and yields. *Biomass Bioenergy* 35(12):4753–4769
- Hamududu B, Killingveit A (2012) Assessing climate change impacts on global hydropower. *Energies* 5(2):305–322
- Harsem O, Eide A, Heen K (2011) Factors influencing future oil and gas prospects in the Arctic. *Energy Policy* 39:8037–8045
- Ibrahim SMA, Ibrahim MMA, Attia SI (2014) The impact of climate changes on the thermal performance of a proposed pressurized water reactor: nuclear-power plant. *Int J Nucl Energy* 2014:1–7
- IHA – International Hydropower Association (2019) Hydropower sector climate resilience guide. <http://www.hydropower.org>. p 7

- IPCC – Intergovernmental Panel on Climate Change (2007) Climate change 2007: synthesis report. In: Pachauri RK, Reisinger A (eds) Contribution of working groups I, II and III to the Fourth Assessment Report of the Intergovernmental Panel on Climate Change. IPCC, Geneva. 104 pp
- IRENA – International Renewable Energy Agency (2019) Global energy transformation: a roadmap to 2050. The International Renewable Energy Agency, Abu Dhabi. p 9
- Lehner AB, Czisch G, Vassolo S (2005) The impact of global change on the hydropower potential of Europe: a model-based analysis. *Energy Policy* 33:839–855
- Linnerud K, Mideksa TK, Eskeland GS (2011) The impact of climate change on nuclear power supply. *Energy J* 32(1):149–168
- Lucena AFP, Szklo AS, Schaeffer R, Dutra RM (2010) The vulnerability of wind power to climate change in Brazil. *Renew Energy* 35:904–912
- Mani M, Pillai R (2010) Impact of dust on solar photovoltaic (PV) performance: research status, challenges and recommendations. *Renew Sust Energ Rev* 14(9):3124–3123
- Manwell JF, McGowan JG, Rogers AL (2002) Wind energy explained: theory, design and application. Wiley, Chichester
- Meral ME, Diner F (2011) A review of the factors affecting operation and efficiency of photovoltaic based electricity generation systems. *Renew Sust Energ Rev* 15(5):2176–2184
- Mukheibir P (2013) Potential consequences of projected climate change impacts on hydroelectricity generation. *Climate Change* 121:67–78
- Panagea IS et al (2014) Climate change impact on photovoltaic energy output: the case of Greece. *Adv Meteorol* 201:1–11
- Pasicko R, Brankovi C, Simic Z (2012) Assessment of climate change impacts on energy generation from renewable sources in Croatia. *Renew Energy* 46:224–223
- Patt A, Pfenninger S, Lilliestam J (2013) Vulnerability of solar energy infrastructure and output to climate change. *Climate Change* 121:93–102
- Pryor SC, Barthelmie RJ (2010) Climate change impacts on wind energy: a review. *Renew Sust Energ Rev* 14(1):430–437
- Rouhany M, Montgomery H (2019) Global biodiesel production: the state of the art and impact on climate change. In: Tabatabaei M, Aghbashlo M (eds) Biodiesel. Biofuel and Biorefinery Technologies, vol 8. Springer, Cham. [https://doi.org/10.1007/978-3-030-00985-4\\_1](https://doi.org/10.1007/978-3-030-00985-4_1)
- Rübelke D, Vögele S (2012) Short-term distributional consequences of climate change impacts on the power sector (who gains and who loses)? *Climate Change* 116:191–206
- Schaeffer R, Szklo AS, Pereira de Lucena AF, Cesar M, Borba BS, Pupo Nogueira LP, Fleming FP et al (2012) Energy sector vulnerability to climate change: a review. *Energy* 38:1–12
- Schaeffli B (2015) Projecting hydropower production under future climates: a guide for decision-makers and modellers to interpret and design climate change impact assessments. *Wiley Interdiscip Rev Water* 2(4):271–289
- Sieber J (2013) Impacts of and adaptation options to extreme weather events and climate change concerning thermal power plants. *Clim Chang* 121:55–66
- Skoplaki E, Palyvos JA (2009) On the temperature dependence of photovoltaic module electrical performance: a review of efficiency/power correlations. *Sol Energy* 83:614–624
- Spalding-Fecher R, Joyce B, Winkler H (2017) Climate change and hydropower in the Southern African power pool and Zambezi River basin: system-wide impacts and policy implications. *Energy Policy* 103:84–97
- Tapiador FJ, Hou AY, de Castro M, Checa R, Cuartero F, Barros AP (2011) Precipitation estimates for hydroelectricity. *Energy Environ Sci* 4:443548
- Teotónio C, Fortes P, Roebeling P, Rodriguez M, Robaina-Alves M (2017) Assessing the impacts of climate change on hydropower generation and the power sector in Portugal: a partial equilibrium approach. *Renew Sust Energ Rev* 74:788–799
- Trenberth KE (2011) Changes in precipitation with climate change. *Clim Res* 47(1/2):123–138
- Troccoli A (2009) Climate and the development community. *Weather* 64(1):25–26
- Turner SWD, Yi J, Galelli S (2017) Examining global electricity supply vulnerability to climate change using a high-fidelity hydropower dam model. *Sci Total Environ* 591:663–675



- Kirsten Ulsrud (2012) Bioenergy and sustainable adaptation to climate change in Africa. In: Janssen R, Rutz D (eds) *Bioenergy for Sustainable Development in Africa*. Springer, Dordrecht, pp 299–308
- van Vliet MTH, Yearsley JR, Ludwig F et al (2012) Vulnerability of US and European electricity supply to climate change. *Nat Clim Chang* 2(9):676–681
- van Vliet MTH, Wiberg D, Leduc S, Riahi K (2015) Power-generation system vulnerability and adaptation to changes in climate and water resources. *Nat Clim Chang* 6:375–380
- Wilbanks TJ, Bhatt V, Bilello DE, Bull SR, Ekmann J, Horak WC, Huang YJ, Levine MD, Sale MJ, Schmalzer DK, Scott MJ, Wright SB (2007) Introduction. In: *Effects of climate change on energy production and use in the United States*, a report by the U.S. Climate Change Science Program and the Subcommittee on Global Change Research, Washington, DC
- World Bank (2009) *World development report 2009: Reshaping economic geography*. The World Bank, Washington, DC

**Open Access** This chapter is licensed under the terms of the Creative Commons Attribution 4.0 International License (<http://creativecommons.org/licenses/by/4.0/>), which permits use, sharing, adaptation, distribution and reproduction in any medium or format, as long as you give appropriate credit to the original author(s) and the source, provide a link to the Creative Commons license and indicate if changes were made.

The images or other third party material in this chapter are included in the chapter's Creative Commons license, unless indicated otherwise in a credit line to the material. If material is not included in the chapter's Creative Commons license and your intended use is not permitted by statutory regulation or exceeds the permitted use, you will need to obtain permission directly from the copyright holder.





# Uncertainties in Rainfall and Water Resources in Maghreb Countries Under Climate Change

# 97

Mohamed Meddi and Saeid Eslamian

## Contents

Introduction .....	1968
Maghreb Countries, Water Resources, and Climate Change .....	1969
Climate Change, Future Projection, and Adaptation .....	1973
Algeria .....	1973
Morocco .....	1982
Recommendations .....	1989
Tunisia .....	1990
Water Potential and Climate Change .....	1990
Future Projections .....	1992
Adaptation .....	1997
Recommendations .....	1998
Conclusion .....	1999
References .....	2000

## Abstract

The vulnerability of the climate change in the South of the Mediterranean's south regions varies depending on the part of their climate which is sensitive to the economy. In Tunisia, agriculture represents 16% of the workforce and 12% of GDP in 2006. In Algeria, agriculture represents 20% of the workforce and 8% of GDP in 2009. In Morocco, agriculture accounts for 40% of the workforce and 17.7% of GDP in 2006. The agriculture is directly related to the availability of water which in turn is directly related to rainfall. The drought has affected all countries of the Maghreb. It is considered the most severe in the history of these

M. Meddi (✉)

Ecole Nationale Supérieure d'Hydraulique de BLIDA, Boufarik, Algeria

e-mail: [m.meddi@ensh.dz](mailto:m.meddi@ensh.dz)

S. Eslamian

Department of Water Engineering, College of Agriculture, Center of Excellence on Risk Management and Natural Hazards, Isfahan University of Technology, Isfahan, Iran

e-mail: [saeid@cc.iut.ac.ir](mailto:saeid@cc.iut.ac.ir)

© The Author(s) 2021

W. Leal Filho et al. (eds.), *African Handbook of Climate Change Adaptation*,  
[https://doi.org/10.1007/978-3-030-45106-6\\_114](https://doi.org/10.1007/978-3-030-45106-6_114)

1967

countries. The drought has forced the agricultural sector in Morocco to the limitation of annual crops which are not needed, the prohibition of any new tree planting and the ban on vegetable crops in dry years. During the years 1987, 1988, and 1989, Tunisia has experienced the most critical drought. It led to a water deficit of around 30%. For Morocco the rainfall shows a negative trend at national and regional scales, and spring rainfall has declined by over 40% since the 1960s. For Algeria, the western region has recorded a considerable reduction in rainfall. The winter rains have decreased between 40% and 70%. Contributions to dams have decreased between 30% and 50%. These changes had a negative influence on the water resource and crop yield. Many programs have been initiated since then to meet the growing demand.

---

**Keywords**

Rainfall · Water resources · Drought · Climate change · Maghreb countries

---

**Introduction**

The issue of climate change settled permanently at the forefront of the news and concerns opinion's public. Confined for a long time to the scientific community and environmental groups, it has emerged in recent years at a government level with the signing of the Kyoto Protocol. But it is mostly the recent weather disturbances (repeated heat waves, devastating hurricanes). Meanwhile, advances in scientific knowledge have gradually transformed what was originally a simple hypothesis – a global warming caused by man – a virtual certainty, although there are still many unknowns about the accurate scope and the pace of the phenomenon.

According to the World Bank (2017), Tunisia, Algeria, and Morocco will become global hot spots by the end of the twenty-first century. Higher temperatures and reduced precipitation will increase the occurrence of droughts in this region (World Bank 2017).

Droogers et al. (2012) found that climatic changes will be responsible for 22% of water shortages by 2050 and 78% of water shortages will be the result of socioeconomic factors for North Africa. During the last century, Algeria has experienced several periods of drought, the most intense were felt in 1910 and 1940 and more persistent in the years from 1975 to 1990 and the beginning of the century. The last drought in the Maghreb countries since five past decades is particularly severe. The period 1950–1975 was wetter comparing to the long-term average, so that from 1977 there is an enough marked drought, unprecedented since the early observations. Algeria and especially the West region have experienced several major droughts in the last century, during the 1940s and 1970s until today (Meddi and Hubert 2003; Habibi et al. 2018; Merabti et al. 2018). The latest one was characterized by its spatial extent and its intensity. In Morocco, droughts continue to increase in both frequency and intensity and impact negatively water resources and agricultural production according to World Bank (2017). Droughts are recurrent and are

becoming more frequent and more severe. Previous recorded droughts, which required government emergency plans, were recorded in 1992–1995, 1998–2001, 2005, 2007, and 2015–2016. The 1994–1995 droughts were particularly strong, resulting in an estimated GDP loss of 7.6% (World Bank Group 2017a). The 1999 drought cost about US\$ 900 million and affected more than one million hectares of cultivated land (World Bank Group 2017a).

To the large spatial variability of precipitations correspond a clear regional difference in the potential of surface water. At the seasonal and interannual variability of rainfall, there is also a strong irregular hydrographical inflow with violent floods and low water periods that can last several months (Meddi and Hubert 2003).

Two-thirds of the territory of Tunisia is characterized by a semiarid climate to arid. This space is subject to drought may be common. The droughts are a common natural phenomenon in Tunisia. They become more and more frequent. The resulting consequences have increasingly serious social and economic impacts. The droughts date back to the last century and Tunisia experienced 31 dry years between 1907 and 2016. More recently, Tunisia experienced a drought during the years: 1982, 1987 to 1989, 1993, 1994, 1995, 1997, 2000, 2001, 2002, 2008, 2010, 2013, and 2016, and the worst drought since more than 50 years was recorded during the years from 1999 to 2002. These droughts cost about \$ 54 million.

The agricultural sector is largely dependent on the availability of water resources, which is the most vulnerable to climate change (Farzaneh et al. 2014). In Algeria, the water consumption in the agricultural sector is about 7 billion m<sup>3</sup>/year where it represents 70% of the total national consumption (<http://www.mree.gov.dz>). In Morocco, irrigation uses 80% of the country's mobilized resources, the rest being reserved for drinking water and industry (MDCE 2016). The used water in irrigation is about 12,038 million m<sup>3</sup> (Dahan 2017). In Tunisia, the volume of water intended for irrigation is about 80% of total water consumption (Chebil et al. 2019). These volumes of water used in irrigation to ensure food security and socioeconomic development in these countries demonstrate the importance of studies and the proposal of scenarios on the impact of climate change on water resources in order to be able to propose measures meet the growing demand in the medium and long term.

Climate projections confirm reduction of rainfall and rising of temperatures (Matari 2016), which will affect the availability of water resources in the medium and long term, hence the need to find ways to mobilize additional water resources (conventional and unconventional) to meet this ever increasing demand.

In this chapter, we will discuss the effects of climate change on water resources as well as adaptation measures in the three Maghreb countries.

---

## Maghreb Countries, Water Resources, and Climate Change

The three Maghreb countries (Algeria, Tunisia, and Morocco) occupy an area of 3,254,000 km<sup>2</sup> (Fig. 1). The Maghreb is crossed from north to west by a mountain system called “Atlas.” It is a barrier between the Mediterranean coast and the Sahara. It begins at the mouth of the Wadi Sous in southwestern Morocco to Cape Bon and



**Fig. 1** Situation of Algeria, Tunisia, and Morocco (Zeroual et al. 2017)

the Gulf of Gabes in northeastern Tunisia. South of the Tell, there is the Saharan Atlas which separates the Algerian highlands from the Sahara. It continues its extension to the east by the Aurès and the Tunisian Dorsal. The Sahara occupies nearly 80 percent of the total area. The most fertile agricultural land is located on the coastal strip that separates the mountains from the sea and the highlands.

These three countries are characterized by considerable demographic growth. They are also facing the phenomenon of climate change which has led to a decrease in rainfall and an increase in temperatures. Rainfall in the Maghreb is already low, with average rainfall volumes of about  $357 \text{ km}^3/\text{year}$ , or 110 mm (Taabni and El Jihad 2015).

Tunisia is located between longitudes  $7^\circ$  and  $12^\circ$  east and  $32^\circ$  and  $38^\circ$  latitudes north. Humid to subhumid areas are in the north. The subhumid to semiarid regions are located in the northwest and the Cape Bon region. The semiarid to arid part is located in central Tunisia. The desert covers the south of Tunisia. In Tunisia, rainfall and temperatures vary considerably from north to south (humid coastal zone to desert conditions in the south) and from east to west. They are influenced by the Mediterranean Sea in the north and in the east and by the Sahara in the south and in the southwest. The rains fall mainly between the months of October and May. Temperatures in the arid and semiarid regions of the south and southwest of the country are generally high, while precipitation is much higher from November to April in the more northerly regions.

The northern part of Algeria is characterized by a Mediterranean climate with a relatively cold and rainy winter and a hot and dry summer. The annual rainfall reaches 400 mm in the west, 700 mm in the center, and 1000 mm in the east for the coast. This type of climate is also found in the Tellian Atlas chains where we record totals ranging from 800 to 1600 mm in the eastern summits, while the values are lowered in the center (700 to 1000 mm) and in the west (600 mm). In the plains of the Tellian Atlas, rainfall varies between 500 mm in the west, 450 mm in the center, and 700 mm in the east (Meddi and Hubert 2003).

In Morocco, rainfall follows a decreasing gradient from north to south and from west to east. Rainfall and temperatures are strongly influenced by the Atlantic Ocean to the west, the Mediterranean Sea to the north and the Sahara to the south and southeast. Most rainfall occurs between October and May like other Maghreb countries (World Bank Group 2017a). Morocco is characterized by spatial and temporal variability of rainfall. The northwest receives more rain than the rest of the country. The average annual rainfall varies considerably. It can reach more than 800 mm on the reliefs, while it hardly exceeds 300 mm on the adjacent plains (World Bank Group 2017).

The climate of Tunisia is strongly influenced by the Mediterranean Sea in the north and east and by the Sahara in the south and southwest. Like other Maghreb countries, rainfall occurs mainly between October and May. Rainfall varies considerably from a relatively wet coastal area to desert conditions in the south. Precipitation exceeds 400 mm/year in the north and reaches 1500 mm/year in the extreme northwest of Tunisia (TSNCUNFCCC 2013). In the central part of the country, precipitation varies between 150 and 300 mm/year (TSNCUNFCCC 2013). Rainfall is becoming scarce and less than 150 mm/year and at the extreme south, rains not exceed 50 mm/year. The average total annual rainfall varies from 1 year to another and is around 36 billion m<sup>3</sup>/year (TSNCUNFCCC 2013).

The decrease in rainfall since mid-1970s has negatively impacted the renewal of groundwater and the dams filling. The scarcity of water resources has had a dramatic effect on the economy in general and agricultural production and agricultural development in these countries in particular. Agriculture is largely dependent on rainfall. In Morocco, irrigated agriculture contributes about 45% of agricultural added value, despite, irrigated agriculture, occupying only 15% of cultivated area. In Algeria, according to the Ministry of Water Resources, the water consumption in the agricultural sector is close to 7 billion m<sup>3</sup>/year where it represents 70% of the total national consumption which is of the order of 10.6 billion m<sup>3</sup>/year (<http://www.mree.gov.dz>). The rate for agriculture corresponds to the world water consumption in irrigation which is around 70%. In Morocco, irrigation uses 80% of the country's mobilized resources, mainly surface water, the rest being reserved for drinking water and industry (MDCE 2016). The used water in irrigation is about 12,038 million m<sup>3</sup> (Dahan 2017). In Tunisia, the volume of water intended for irrigation about 80% of total water consumption (Chebil et al. 2019). This volume was in 2004 of about 2130 million m<sup>3</sup> for an area of 375,000 ha and will be 2145 million m<sup>3</sup> in 2011 and 2035 million m<sup>3</sup> in 2030 for an area of 467,000 ha ([www.environnement.gov.tn](http://www.environnement.gov.tn)). In the future, rational pricing encourages farmers to use more and more water-saving technologies and varieties that consume less water.

The renewable water resources in the three Maghreb countries are estimated at 43 km<sup>3</sup>, where surface water accounts for 73% (Taabni and El Jihad 2015). In 2010, the average per capita renewable water provision for the Maghreb countries was 548 m<sup>3</sup>/person/year in 2010, and by 2030 it will be less than 290 m<sup>3</sup>/person/year (Taabni and El Jihad 2015). These values are well below the standard set by the World Health Organization (WHO) of 1000 m<sup>3</sup>/person/year.

All these statistics show the importance of the development of water resources management scenarios in the Maghreb countries to meet the increase of water

demand for drinking water supply and especially for irrigation, so to increase the capacity of agricultural productivities, and sustainable production systems to reduce the problem of poverty and unemployment knowing that the agricultural sector is the main employer in the world with 40% of the world population.

The Maghreb countries are located in an arid to semiarid region. The climate is Saharian in the southern, oceanic in the western, and Mediterranean in the north. The population of Morocco, Algeria, and Tunisia was already 65 million in 2000 and attended more than 75 million in 2010. A population that is gathered for more than two-thirds on the shores of the northern Atlantic and Mediterranean region, the life of people in these countries is closely linked to climate and to these changes.

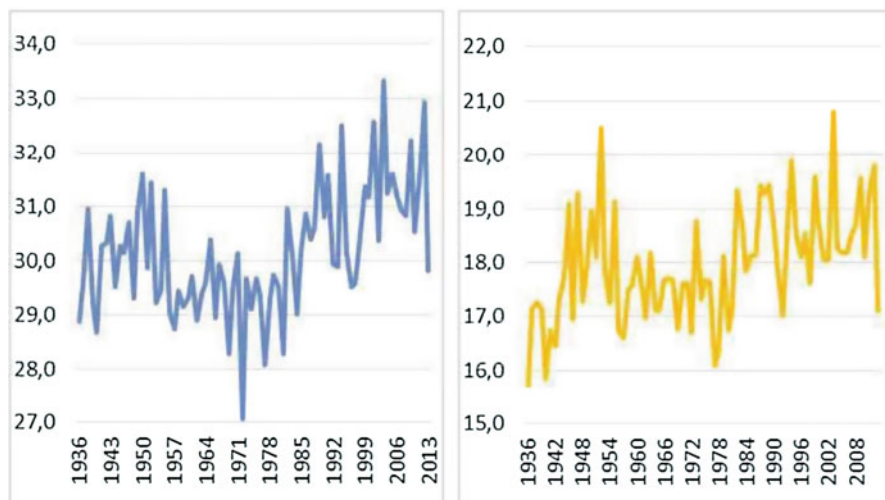
Climate data recorded in the Maghreb region during the twentieth century indicate a warming in this century estimated at more than 1 °C, despite its small share in global emission of greenhouse gases (GHGs) ([www.anme.nat.tn](http://www.anme.nat.tn)). These data also show an increase in droughts and floods. Thus, we started a drought every 10 years at the beginning of the century to 5–6 years of drought in a decade now (Agoumi 2003).

The North African countries suffer from recurrent droughts, whose frequency has increased over the last 40 years. Increasing climate variability affects in particular the center and the north of these countries and the predictions of the Intergovernmental Panel on Climate Change (IPCC 2013) are worrying, even alarming. They indeed show a worsening trend for future decades (OSS 2009). The central Maghreb is characterized by a low average annual rainfall and strong fluctuations in rainfall. In recent decades, he suffered several episodes of drought and the latter tends to be more structural than cyclical. In years of drought, the scarcity of rainfall affects pluvial agriculture which occupies an important agricultural area in the region but also all other sectors dependent on water resources. Irrigated agriculture is also affected and measures of restrictions on water allocation are generally applied (OSS 2009).

Climate data recorded in the region during the twentieth century indicate a warming during this century estimated at more than 1 °C with an accentuated trend in the last 30 years (Fig. 2). These data also show a net increase in the frequency of droughts and floods. Thus, we started a drought every 10 years at the beginning of the century to 5–6 years of drought in a decade now. The general circulation models, even if they are not accurate enough for this region does not have a centered model converge to estimate a likely warming in the region of about 2° to 4° during the twenty-first century.

Trend analysis of rainfall variability in the Mediterranean region shows a significant decrease in rainfall from 1970 (Knippertz et al. 2003; New et al. 2001; Rodrigo and Trigo 2007; Khomsi et al. 2013). This downward trend is higher in winter (Jacobeit 2000; Giorgi 2002). In the Maghreb, Trambly et al. (2013) observed a negative trend in precipitation intensity, in annual maximum precipitation, and in the 95th percentile of precipitation.

The vulnerability of the climate change in the Mediterranean's south regions varies depending on the part of their economy sensitive to climate (agriculture, tourism, infrastructures, energy, and ecosystem). In Tunisia, agriculture represents 16% of the workforce and 12% of GDP in 2006 (BCT 2007). After a decline of 7% in 2005 caused by drought, its rate of growth was 2.5% in 2006 and 2.1% in 2007.



**Fig. 2** Evolution of average maximum and minimum temperature in Algiers at Dar El Beida station 1936–2012 (Matari 2016)

For Algeria, agriculture represents 20% of the workforce and 8% of GDP in 2009. For Morocco, agriculture accounts for 40% of the workforce and 17.7% of GDP in 2006. This sector in these countries is directly related to the availability of water which in turn is directly related to rainfall.

## Climate Change, Future Projection, and Adaptation

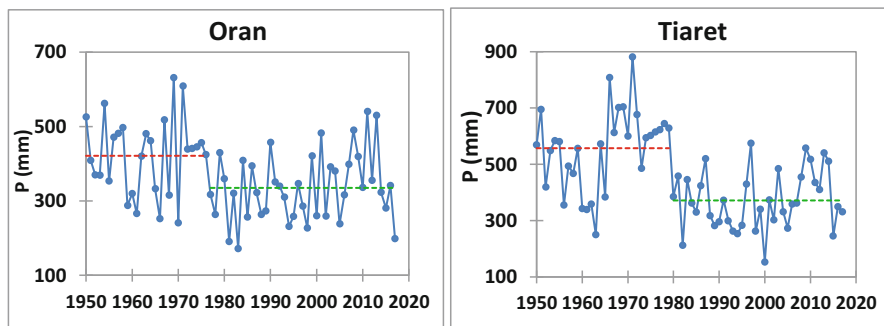
### Algeria

#### Water Potential and Climate Change

Water potential of Algeria is estimated at 19.4 billion  $\text{m}^3/\text{year}$  according to the Ministry of Water Resources. The groundwater resources contained in the northern aquifers of the country (renewable resources) are estimated at 2 billion  $\text{m}^3/\text{year}$  and the surface water is estimated at 12 billion  $\text{m}^3/\text{year}$ . The water reserves of southern Algeria are very important and are of the order of 40,000 billion, this resource is not renewable according to the Ministry of Water Resources.

Water and its management represent a major problem in Algeria following specially in the South. It is amplified by the reduction of rainfall affecting the country since the 1970s. For example, the rainfall, in the northwest, decreases more than 20% (Figs. 2 and 3) and the temperature has increased as shown in Fig. 3. Droughts in rehearsing raise represent the most serious concerns for citizens and managers of the water sector. The climate scenarios and the availability of water are alarming and might have direct and indirect bad consequences on the potential of water resources (quantity and quality) and on their use in the Drinking Water Supply, in agriculture, and in industry.





**Fig. 3** Trend of annual rainfall variability at Oran and Tiaret stations

Water resources in Algeria are limited, vulnerable, and unevenly distributed in terms of geography. Many dams have been constructed to develop surface water storage capacity, whereas in 1962 there were only 13 dams capable of storing 450 million cubic meters of water, mainly used for irrigation of the plains in the west of the country (<http://anbt-dz.com/>). The storage capacity has multiplied several times and has reached eighty dams with a capacity of more than eight billion cubic meters in 2017.

According to the Ministry of Water Resources (<http://www.mree.gov.dz>), drinking water supply, after being confined in big cities, the network connection rate has increased from 78% in 1999 to 98% in 2017. The network is over 127,000 km in 2017. The increase in water availability per capita has increased from 123 l in 1999 to 180 l in 2017, but water distribution systems still lose about one-third of the water distributed due to leaks.

### Immediate Water Needs

Water consumption in the agricultural sector is about 7 billion cubic meters per year, which is about 70% of the total volume of water consumed nationally. The drinking water consumption of the population is estimated at 2.5 billion cubic meters per year.

### Future Water Needs

Climate change, strong urban and demographic growth, and the nature of water resource management will exacerbate water stress. The demand for drinking water can easily exceed 4 billion cubic meter per year over the next few decades.

In agriculture, we have two possible scenarios:

- **The First Scenario:**

Represented by a slight change in the current management of water resources, an average increase in irrigated land and the maintenance of the current quality of agriculture, the demand for irrigation water will reach 15.4 billion m<sup>3</sup>

- **The Second Scenario:**

To improve the efficiency of water resources management, increase the irrigated area to 2,000,000 hectares and develop cereal and fodder crops, the demand for irrigation water will increase to 20 billion m<sup>3</sup>.

In 1962, theoretical water availability per inhabitant per year was in the order of  $1500 \text{ m}^3$ , in 1990 was  $720 \text{ m}^3$ ,  $680 \text{ m}^3$  in 1995,  $630 \text{ m}^3$  in 1998,  $500 \text{ m}^3$  in 2009, and it will be only  $430 \text{ m}^3$  in 2020.

Algeria is one of the countries where water availability per capita is below the threshold set by the World Bank ( $1000 \text{ m}^3/\text{hab}/\text{an}$ ). Water resources are estimated to 19 billion  $\text{m}^3$  (corresponding to about  $600 \text{ m}^3/\text{hab}/\text{an}$ ). The mobilization of water is facing the following problems:

- The spatial distribution of surface water resources requires substantial transfers to meet the needs of the less fitted regions; these facilities and operations of water mobilization are more and more expensive.
- The effectiveness of reservoir dams is reduced by the high evaporation affecting water bodies (reservoirs evaporate in Algeria from 1.3 to 2.2 m/year and the problem of siltation ( $32 \text{ million m}^3/\text{year}$  for 52 dams whose initial capacity is about  $5.2 \text{ billion m}^3$ ).
- The rate of loss in the networks of drinking water varies from 30% to 40%.

In Algeria, the observed climate change across the globe has resulted in:

- An increase in the average, minimum, and maximum temperature recorded on all stations in northern Algeria since the 1970s and that continues to these days.
- On other records, the impacts of climate change have caused our country endemic drought since 1970, resulting in a worsening desertification with a degradation of more than 8% of the forest, wind, and water erosion of soil.
- A trend in rainfall during the past 25 years had a negative impact on water resources by:
  - A rainfall deficit of about 30%
  - An impact on the level of filling of dams and groundwater recharge
  - The impact on the socioeconomic structure
  - An impact on the environment (desertification, urban pollution, industrial and agricultural, decline of groundwater levels and salinization of water result of the overexploitation of groundwater and drought)

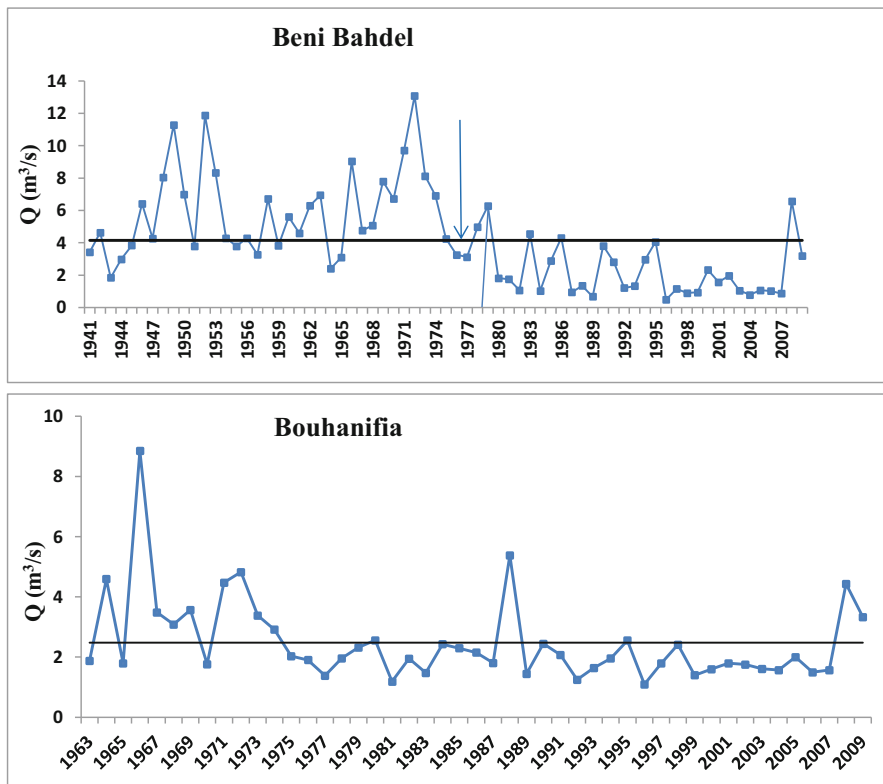
### **Impact of Climate Change on Superficial and Underground Water Resources**

Indeed, the 90 billion  $\text{m}^3$ , which precipitate in average each year, only 12 billion  $\text{m}^3$  is surface water resources and two-thirds of this volume could be mobilized.

The decrease in rainfall creates a water deficit. It constitutes the most important factors to lead to reduce the flow of the seasons of winter and spring.

For example, lower liquid intake, on an annual scale, at the outlets of five basins in western Algeria (Fig. 7), varies from 16% (Basin of Sidi Ali Ben Youb) to 55% (chouly basins). At Bouhanifia dam, flows have registered a reduction of about 56% since 1979 date of change in the hydrological regime and 55% of reduction at Beni Bahdel dam since 1974 (Fig. 4).

At the level of the plain of Ghriss (west of Algeria) the exploited water varies from 72 to  $88 \text{ hm}^3/\text{year}$ , while the natural recharge is about  $64 \text{ hm}^3/\text{year}$  (Fig. 5).



**Fig. 4** Inflow to Beni Bahdel and Bouhanifia dams

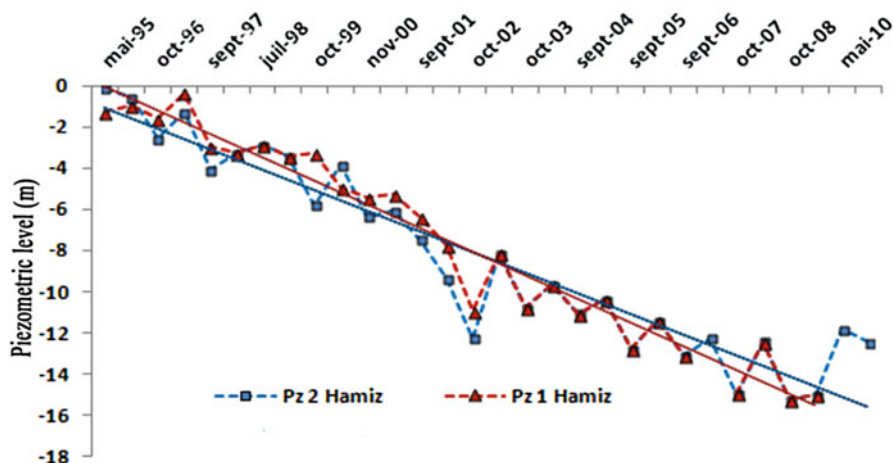
This decrease is mainly due to the lower rainfall in recent decades. This imbalance has led to a lowering of the groundwater from 5 m to 40 m.

For the Chellif Basin, the total number of wells and drillings increased steadily from 5 in 1850 to 2080 in 2005. This increase in the number of wells and drillings resulted in a change in the amount of mobilized water. These volumes were 3.75 Mm<sup>3</sup> in 1970 and 110.7 Mm<sup>3</sup> in 2005 in the high and medium chellif (Meddi and Boucefiane 2009).

### Future Projection

The study of the temporal and spatial evolution of surface and underground water resources is considered as a major decision-making tool for the socioeconomic development of the Maghreb countries.

Dams are filled mainly by the few floods recorded during the rainy season. The recharge of the aquifers is ensured by infiltrations which occur in winter and spring. This recharge has become insufficient since the mid-1970s following the decrease in rainfall (Meddi and Hubert 2003; Hallouz et al. 2013; Zeroual et al. 2017) and the



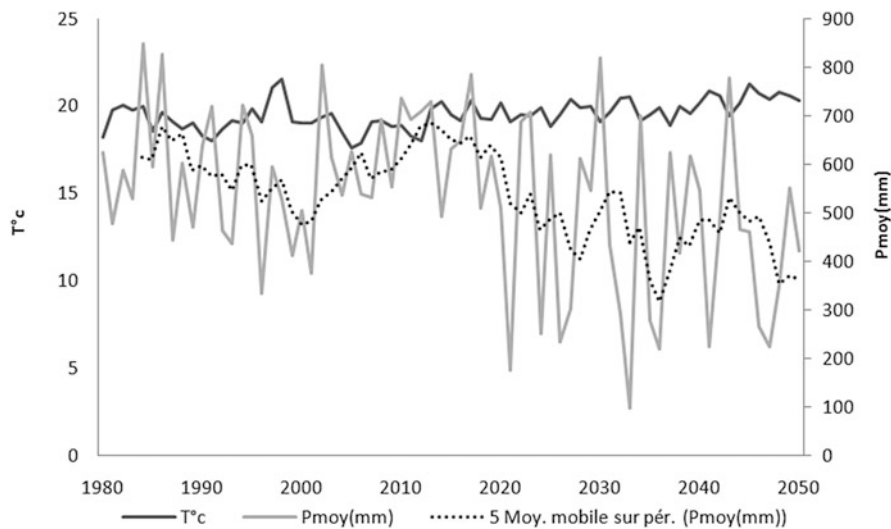
**Fig. 5** Evolution of the piezometric level in Pz1 and Pz2 Hamiz, plain of Mitidja (1995 to 2011)

overexploitation of groundwater to meet irrigation water and drinking water needs. The drop in piezometric levels reached 40 m for the Mitidja Plain (Demmak 2008).

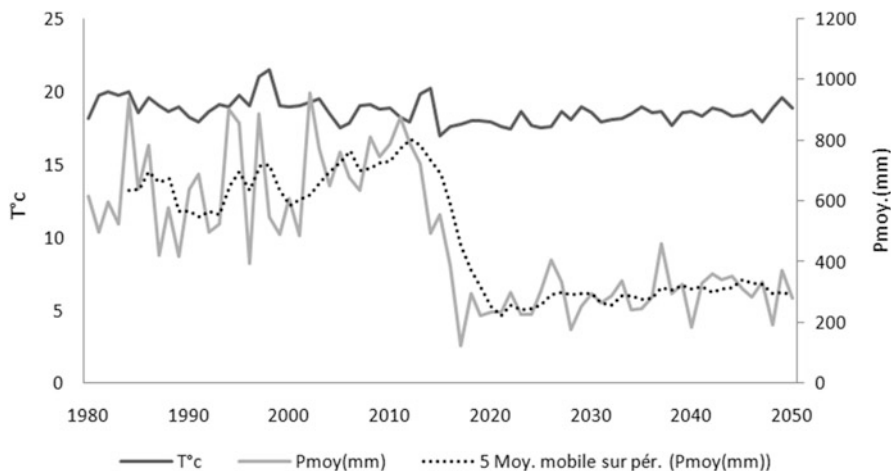
Climate projections will make it possible to establish scenarios for the availability of water resources at future horizons. Projections of the spatio-temporal variability of precipitation and temperature for the periods 2006–2060 and 2045–2100 performed by Zeroual (2017) using the RCA4 model (NorESM1-M), scenarios RCP4.5 and RCP8.5, for the periods 2006–2060 and 2045–2100 showed a stabilization of average rainfall compared to the period from 1951 to 2005 in eastern and southern Algeria and a decrease in the western part of Algeria (Figs. 6 and 7). This decrease will change from RCP4.5 to RCP8.5 and from 2006–2060 to 2045–2100. The climate models predict a decrease in precipitation and an increase in temperatures both on annual and monthly scales for the periods 2006–2060 and 2045–2100 (Zeroual 2017).

The impact on the flows will be very important as shown by Kahlerras et al. (2018) in a work on the Mazafran Basin (Fig. 8), in the center of Algeria. The Oued Mazafran, which drains a basin of 280 km<sup>2</sup>, for the RC4.5 scenario, will record a decrease in flows will be of the order of 29% in 2033 to reach a volume of 134.01 Mm<sup>3</sup> compared to the reference period (1998–2014) which recorded an average volume of 189.85 Mm<sup>3</sup>. For scenario RC8.5, a decrease will be of the order of 31.6% in 2028 with a volume of 129.8 Mm<sup>3</sup>, by 2040, the volume will be of the order of 129.9 Mm<sup>3</sup>. These 2 years will be the least rainy with 178.4 mm/year and 184.8 mm/year, respectively (Kahlerras et al. 2018).

Kahlerras et al. (2018) have shown that the demand for water for the Mazafran Basin, whose population is estimated at about 615,956 inhabitants in 1998 and will be of the order of 1,724,880 inhabitants by 2050, there will be a recovery of demand until 2040, the deficit after this date will be of the order of 3.44 Mm<sup>3</sup> in 2045 and will

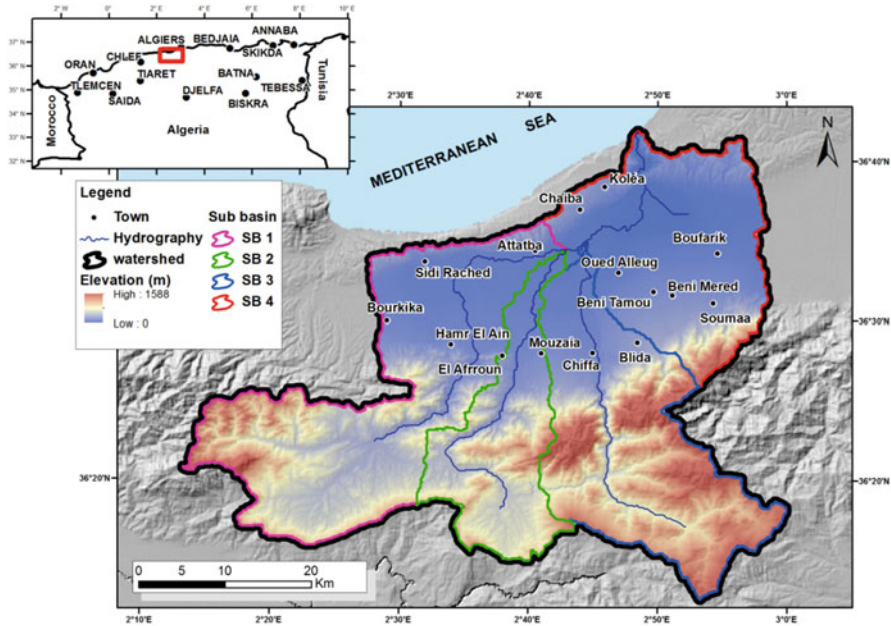


**Fig. 6** Projected temperature and rainfall trend change at the time horizon of 2050 (scenario RC4.5) at the Mitidja plain (Kahlerras et al. 2018)

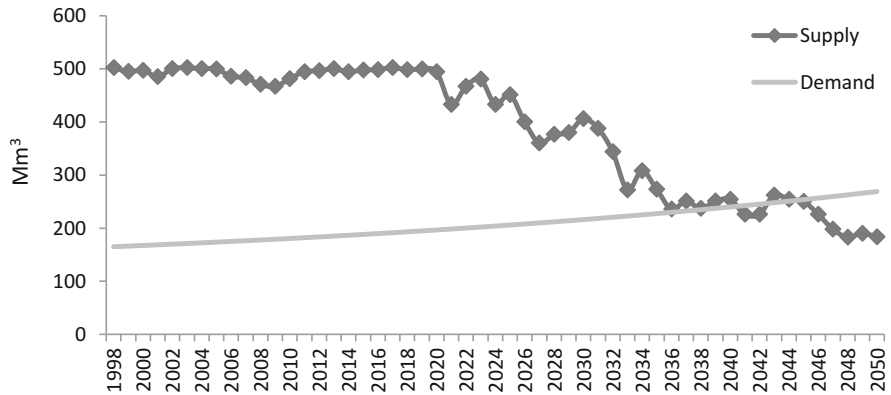


**Fig. 7** Projected temperature and rainfall trend change at the time horizon of 2050 (scenario RC8.5) at the Mitidja plain (Kahlerras et al. 2018)

reach 95.3 Mm<sup>3</sup> in 2050 for scenario RC4.5 (Fig. 9). The situation will be more critical for the pessimistic scenario (RC8.5) where the rupture between supply and demand will be recorded as early as 2025. The deficit will be of the order of 56.65Mm<sup>3</sup> in 2030 and will reach 130.95 Mm<sup>3</sup> in 2050 (Fig. 10).

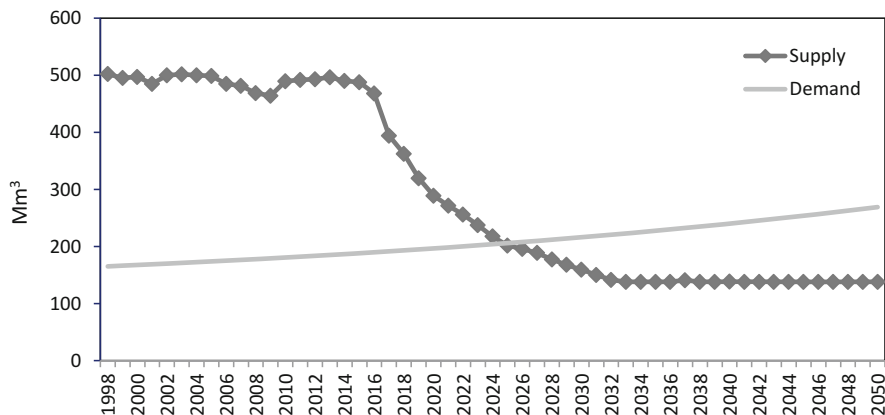


**Fig. 8** Geographical situation of the Mazafran watershed (Kahlerras et al. 2018)



**Fig. 9** Assessment of water resources management for the RC 4.5 scenario (Kahlerras et al. 2018)

For basins located in western Algeria, the region most affected by the reduction in rainfall by 25% (Meddi and Hubert 2003), winter flows will show a clear downward trend, mainly due to the decrease in rainfall and the increase in PET for the two scenarios RCP8.5 and RCP4.5. On the other hand, spring flows will increase according to RCP 8.5 and decrease according to RCP 4.5. In terms of observed differences, the RCP 8.5 scenario forecasts a decrease in winter flows of about 33% on average in all the studied basins by 2039, 31% by 2069, and 50% by the end of



**Fig. 10** Assessment of water resources management for the RC 8.5 scenario (Kahlerras et al. 2018)

the twenty-first century. The RCP4.5 scenario predicts a decrease of about 50 to 60% for all horizons. In addition, the decrease is estimated at 80% for spring flows according to the RCP4.5 scenario. In contrast, the RCP8.5 scenario forecasts a 25% increase for the same season (Haddour et al. 2019).

### Palliative Measurements

To cope with the change in rainfall reduction, Algeria has undertaken a major program based on large transfers and the use of the non-convent water.

The state has made a considerable effort to increase the connection rate, mainly in rural areas. This rate increased from 44% for some rural regions to more than 60% (<http://www.mre.gov.dz>). The recent decision to use non-conventional water, desalination, will provide a substantial addition to alleviating the suffering of populations of large cities and rural areas. An emergency program was decided by the government for commissioning 21 desalination stations with a total capacity of 57,500 m<sup>3</sup>/day (<http://www.mre.gov.dz>). For this project, the Government aims to strengthen the water supply of some urban areas situated in the coasts in the summer season. Water dams originally planned for these towns will be transferred to the interior cities. This procedure will develop these towns and villages that are in poverty and enable people to develop agriculture and prevent diseases inherent to the lack of water (<http://www.mre.gov.dz>).

During the warm season, the deficit is growing due to the increasing demand and declining reserves of conventional water (<http://www.mre.gov.dz>). However, these programs cannot alone solve the water problem in the long term. Rigorous management and increased storage capacities of surface and groundwater are essential to meet the demand. The reuse of wastewater, especially in aquifer recharge and irrigation, will increase, with no doubt, the water resource available in the medium and long term (<http://www.mre.gov.dz>).

There is a considerable waste in agriculture. To remedy to this, it is necessary to restructure the peasants in unions capable to organize the operation of irrigation and to modernize, as appropriate, irrigation techniques.

For a better management, decentralization of the management of water supply and sanitation in order to promote the emergence of effective management by elected authorities and representative committees of citizens. We must encourage and facilitate management by major river basins (basin agencies).

Once the impacts on water resources will be determined for the main socioeconomic activities, strategies to adapt to the negative impacts of these climate change scenarios for Algeria can be developed for the benefit of policy makers. They will be able to draw a proper water policy in the medium and long term.

### Large Transfers

To cope with water shortages in certain parts of the country, the government has started the constructions of several large transfers across the country, we give as examples:

- Beni Haroun Development in the east of the country: 242 million m<sup>3</sup> will be used to supply drinking water for 4.62 million inhabitants of several department: Jijel, Mila, Oum El Bouaghi, Batna, Constantine, Ain M'lila, and Khenchela. Also, 262 million m<sup>3</sup> for irrigation of 30,000 hectares.
- Mobilization of water resources in Algiers: This project consists of projects set to ensure an annual volume of 595 million m<sup>3</sup>. A total of 435 million m<sup>3</sup>/year for drinking water supply for 7.95 million inhabitants and 160 million m<sup>3</sup> for the irrigation of about 30,000 ha.
- Mobilization of water resources in western Algeria: The development of the water production of Chellif-Kerrada called MAO provides 155 million m<sup>3</sup>/year for the drinking water in the corridor Mostaganem-Arzew-Oran.

### Desalination of Seawater

A very ambitious program was initiated to meet the water demand constantly increasing through desalination of sea water. This resource is inexhaustible and can be exhausted on a coast of 1200 km. In addition, the population and the industries that are large consumers of water are near the sea to defend this approach. The field of desalination of seawater has in recent years a remarkable technological step through the development of different processes. The program is composed of large monoblock stations and a desalination plant. For the first category, 21 stations with a total capacity of 57,500 m<sup>3</sup>/day:

- 13,000 m<sup>3</sup>/day for the western region.
- 22,500 m<sup>3</sup>/day for the central region
- 7000 m<sup>3</sup>/day for the east region

For the large stations, the regional distribution is made as follows: western region (1.29 million m<sup>3</sup>/day), the central region (0.45 million m<sup>3</sup>/day), and the eastern region (0.15 million m<sup>3</sup>/day).



## Recommendations

- Algeria will build more than 40 dams to reach 130 dams by 2030 to increase the mobilized water resources.
- Reduce leakage from urban and rural drinking water systems by 30% to 20% by 2030.
- Save between 20% and 25% of water intended for irrigation by 2030.
- Economy of 20% (1.4 billion m<sup>3</sup>) in agriculture could provide drinking water to half of the Algerian population
- The used water treatment stations can process up to one billion m<sup>3</sup> in the future. This unconventional water resource is an excellent addition to irrigation and can easily cover more than 100,000 hectares.
- Integrated Water Resources Management (IWRM) is a good solution for smart and optimal management through the development of scenarios to counter the impacts of future climate change.
- Develop integrated management of water resources by basin.
- The development of research projects to be conducted by a consortium of farmers and research laboratories to develop optimized complete solutions for the reuse of treated water in irrigation.

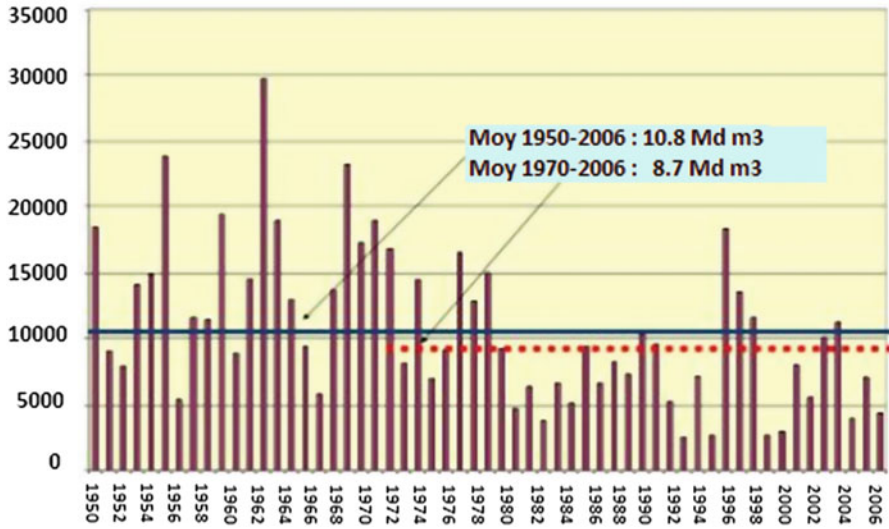
## Morocco

### Water Potential and Climate Change

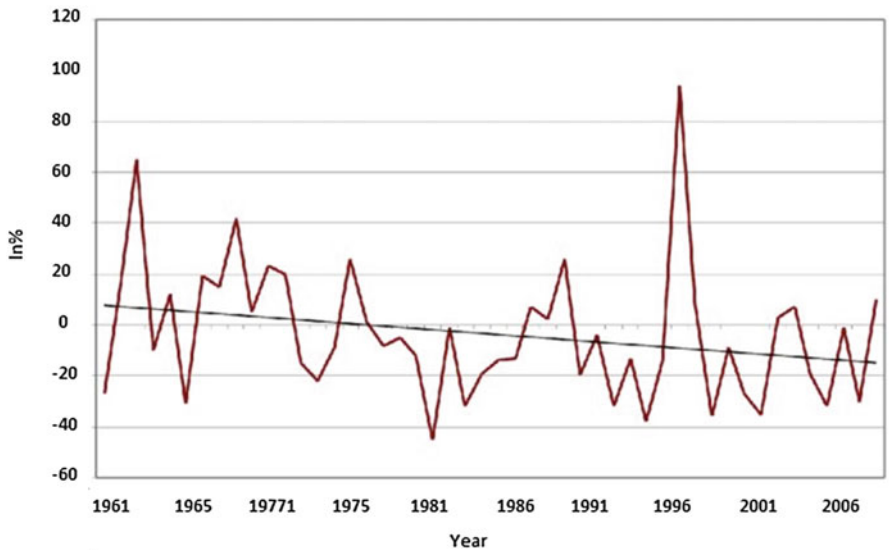
Morocco has a potential of water estimated at 22 billion m<sup>3</sup>, 18 billion m<sup>3</sup> of surface water, and 4 billion m<sup>3</sup> of groundwater (Choukr-Allah 2011). Morocco counted 135 large dams with a total capacity of 17,500 million m<sup>3</sup> in 2009, as well as about 100 small dams with a capacity of 100 million m<sup>3</sup> for local needs in drinking water, irrigation, and livestock, and there are also 13 systems for transferring water between watersheds (<https://water.fanack.com/morocco/water-infrastructure-in-morocco/>). The national water strategy foresees the construction of about 60 large dams by 2030, with a total capacity of about 7 million m<sup>3</sup> plus 1000 small dams for local development (Alaoui 2013). The water resources reduce in particular because of overexploitation (Fig. 11). This depletion will increase with the advent of climate change. Similarly, the development of industrialization and intensification of agriculture water consumption would cause further degradation of groundwater.

In addition, water resources will be subject to further exploitation, the domestic and industrial wastewater will constitute a problem concern threatening the human health and the environment. Thus, the urban wastewater was about 600 Mm<sup>3</sup>/year in 2015, it will increase to about 750 Mm<sup>3</sup>/year in 2030 and 900 Mm<sup>3</sup>/year by 2050 (World Bank Group 2017b).

The recorded rainfall shows a negative national trend (Fig. 12). The spring rains have fallen over 40% since the 1960s. The drought seems to become more persistent over time. The temperature has increased as shown by the Fig. 13. The dry maximum length is rising during the rainy season, significantly during the end of this season (February to April) where it increased 15 days since the 1960s. At the same time, the

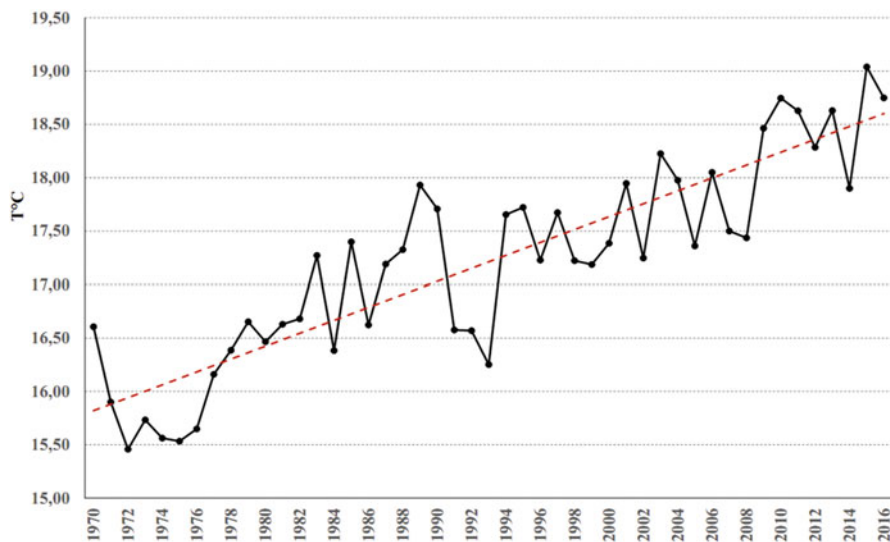


**Fig. 11** Evolution of the water contributions in dams of Morocco (Ben Abdelfadel and Driouech 2008)



**Fig. 12** National averages (%), defects of the cumulative rainfall totals annual, calculated on the 14 meteorological stations in Morocco (1961–2008), Driouech (2010)

total number of rainy days shows a negative trend and indicates an increase in the annual number of dry days. Many regions have become drier between 1961–1985 and 1986–2005 (Ben Abdelfadel and Driouech 2008).



**Fig. 13** Average annual temperatures at the Oujda station in Morocco (El Hafid et al. 2017)

The drought has led the agricultural sector in Morocco, for example, to limit the not needed annual crops, to the prohibition of any new tree planting and to the prohibition of vegetable crops in dry years from 1981 to 1982.

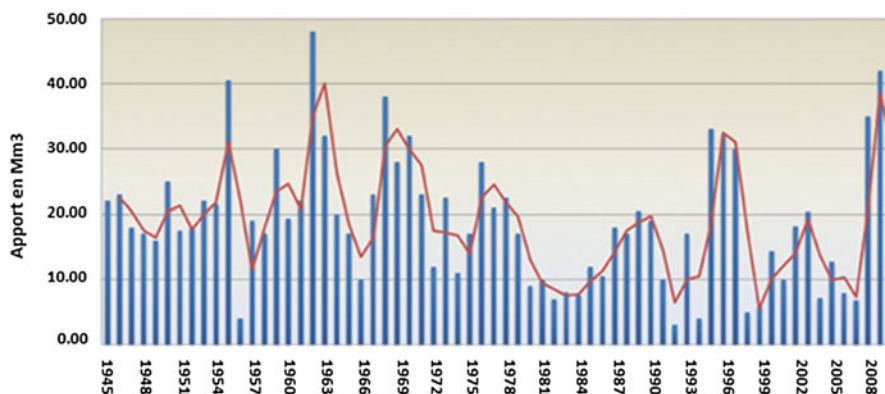
The potential of renewable water resources is estimated at 22 billion m<sup>3</sup> per year of which 18 billion m<sup>3</sup> of surface water. From the available potential two-thirds are currently mobilized and used up to 88% in irrigation and 12% in the drinking water.

Morocco's Third National Communication on Climate Change 2016 has shown that, according to observed climate trends and long-term projections, climate change is already underway based on the climate trends observed between 1960 and 2005 (MDCE 2016). Average annual temperatures have increased from 1.0 to over 1.8 °C (MDCE 2016). Precipitation has declined between 3% and 30% with a 26% decline in the northwestern region of Morocco (MDCE 2016). On average, warming varied between 1 and 3 °C depending on the region during the period 1998–2007 compared to 1971–1980 (MDCE 2016).

### Surface Water

According to the second submission, river flows have recorded a 20% reduction since 1950 (SCNCCRM 2009). Knowing that the surface water resources on the whole territory are evaluated in average year to 18 billion m<sup>3</sup>, varying, according to the years, from 5 to 50 billion m<sup>3</sup>. More than 51% of the surface water resources are produced at the level of four hydrographic basins (Loukkos, Tangier, Mediterranean Coastal, and Sebou) (SCNCCRM 2009).

The last four decades have seen a marked decrease in stream flows and natural recharge of groundwater (Sinan and Belhouji 2016). The decreases in superficial



**Fig. 14** History of surface water supplies in Morocco 1945–2010 (MDCE 2014 in Sinan and Belhouji 2016)

flows reached nearly 20% between 1970–2006 and 1950–2006 and exceed 70% in certain regions of Morocco (Sinan and Belhouji 2016), Fig. 14.

To show the probable effects of climate change on surface water resources, two basins feeding the dams of Hassan Addakhil (located on Wadi Ziz in the south-east) and Idris I (located on Wadi Innaouene, tributary of the oued Sebou, central Morocco) are considered. In Morocco, like other countries around the Mediterranean, surface water flows depend mainly on rainfall.

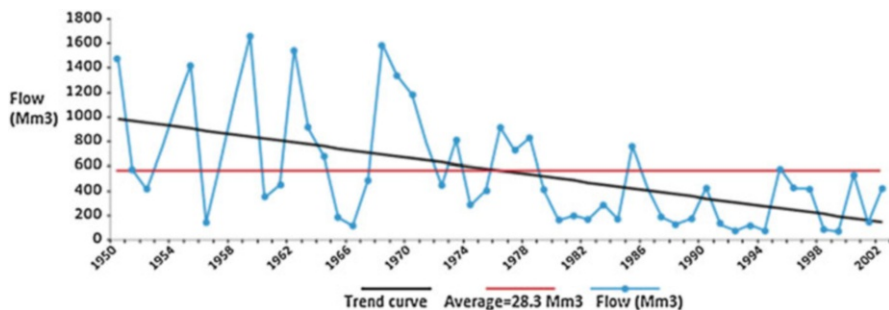
Figs. 15 and 16 present the history of water inflow in the Hassan Addakhil (by Wadi Ziz) and Idriss I (by Wadi Inaouene, Basin of Sebou) dams over the period 1950–2002 (Sinan et al. 2009; Sinan and Belhouji 2016; MDCE 2016). They show a clear downward trend in these inputs, especially since the beginning of the 1980s (more than 30 years ago), a clear consequence of the negative effects of climate change. The average water inflow during this period (1950–2002) was respectively 122 Mm<sup>3</sup>/year and 516 Mm<sup>3</sup>/year for the Hassan Addakhil and Idriss I dams (Sinan et al. 2009; Sinan and Belhouji 2016).

The water resources of the two basins will record decreases as below compared to the end of the twentieth century (Sinan and Belhouji 2016):

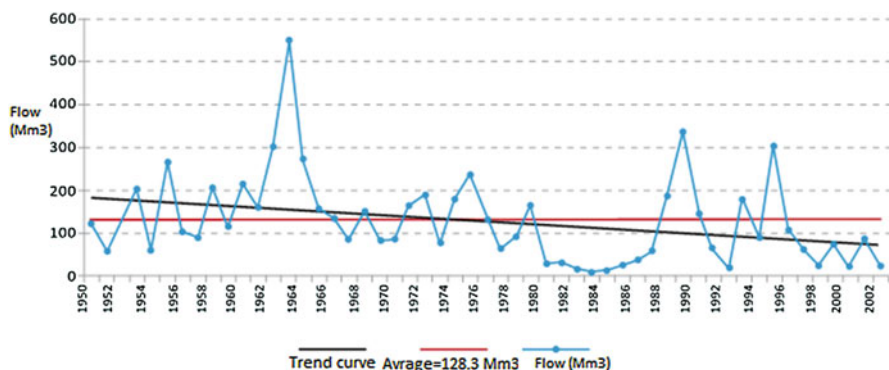
- 2020: –7.6% (optimistic scenario) and –8.6% (pessimistic scenario)
- 2050: –2.3% (optimistic scenario) and –12.8% (pessimistic scenario)
- 2080: –7.6% (optimistic scenario) and –40.6% (pessimistic scenario)

## Groundwater

Groundwater represents about 20% of the potential of Morocco's water resources. These waters are of great importance for the socioeconomic development of the Kingdom. Morocco has 96 aquifers, 21 of which are deep and 75 shallow and cover a total area of 80,000 km<sup>2</sup>. The level of these aquifers shows a continuous decrease due to drought, reduction of natural recharge, and overexploitation. This reduction in groundwater level is about 2 m each year. The volume of groundwater withdrawn



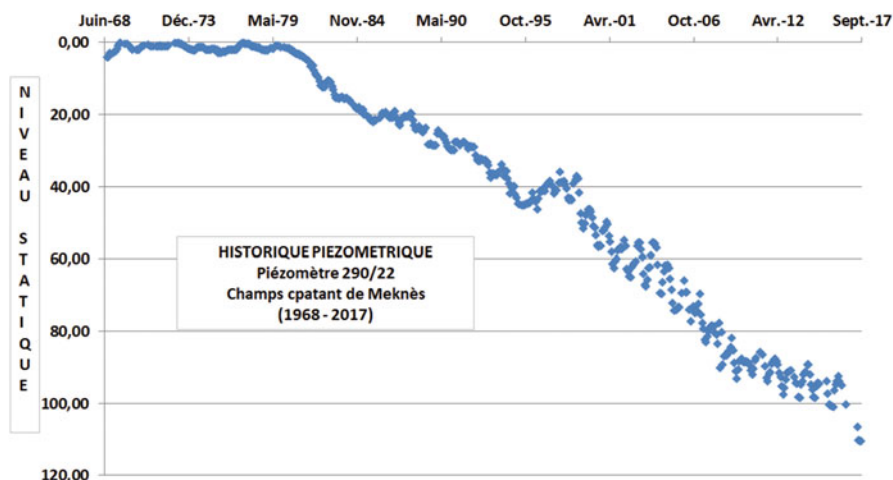
**Fig. 15** Historical water inflow in Hassan Addakhil Dam by Wadi Ziz (Sinan et al. 2009)



**Fig. 16** History of water supplies in the Idriss I dam by the Inaouene wadi – Sebou basin (Sinan et al. 2009)

from the aquifers exceeds the renewable water resources. In fact, recent estimates estimate withdrawals at 5 billion  $\text{m}^3/\text{year}$ , which is a reflection of the nonrenewable potential of groundwater with an average volume of 1 billion  $\text{m}^3/\text{year}$ . This over-exploitation has led to a general decline in groundwater levels sometimes exceeding 2 m/year in some aquifers (Sinan and Belhouji 2016).

The impact of reduced rainfall and consequently the groundwater recharge, as well as the overexploitation of groundwater has led to the lowering of the piezometric level. According to Amraoui (2019), between 1980 and 2017, the deep aquifer of Saiss plain at the level of the piezometer 290/22, controlling the region of Meknes, shows an average decrease of 3 m/year (Fig. 17). Groundwater exploitation in this area increased from 4 million  $\text{m}^3$  in 2005 to almost 10 Mm in 2014 (Ameur 2017). For this aquifer, the Sebou Watershed Agency (ABHS) has identified more than 9000 water points exploiting the water table, most of which are not authorized (Amraoui 2019). This is the equivalent of 4 holes per  $\text{Km}^2$  (Amraoui 2019). In terms of use, agriculture would take 225 million  $\text{m}^3$  annually and 100 million  $\text{m}^3$  of drinking water (Amraoui 2019).



**Fig. 17** Decrease of the level of aquifer of Siass plain, Morocco (Amraoui 2019)

The impact of climate change and reduction of water resources have led to:

- Worsening of water supply in rural areas
- Very important economic impact on the agricultural sector: drop in grain production, irrigation water deficit, increased unemployment in rural areas
- The impact on water quality

### Future Projections

Projections of climate to future horizons indicate a negative trend of annual rainfall that varies between 10 and 20% to reach 30% in Saharan regions by 2100. The trend in annual average temperatures show an increase of 0.5 to 1 °C in 2020 and 1 to 1.5 °C in the 2050 and 2080 horizons across the country (MDCE 2016; Sinan and Belhouji 2016). The observed temperature has increased by 0.5 °C each decade since 1970. It is above the world average of about 0.15 °C (World Bank Group, 2017). The forecasts show that Morocco will reach 3 to 7 °C from here at 2100, with 4 to 7 °C for the summer months (June, July, and August). Annual rainfall is expected to decrease by 10 to 40%, especially by 10 to 30% during the rainy season from October to April and by 10 to 40% during the dry season from May to September (World Bank Group 2017a).

The water potential in Morocco is estimated at 22 billion cubic meters per year. With a forecast to 38 million inhabitants in 2030 and despite a considerable effort, in terms of construction of hydraulic structures and access to unconventional resources, this quantity of water could fall to 500 m<sup>3</sup> by 2030 under the pressure of climate change, population growth, and pollution increase in economic activity (INDC 2015). Over the next 20 years, Morocco will be more vulnerable to drought and other extreme weather events (World Bank Group 2017b).

These projections also show that the water/year/inhabitant capital would be significantly reduced by 2050 and 2080, thus creating a situation of water scarcity (water capital/year/inhabitant of less than 500 m<sup>3</sup>/year/inhabitant) between the 2030 and 2050 horizons for all considered socioeconomic scenarios (Sinan and Belhouji 2016; MDCE 2016), Table 1 and Fig. 18.

### Palliative Measurements

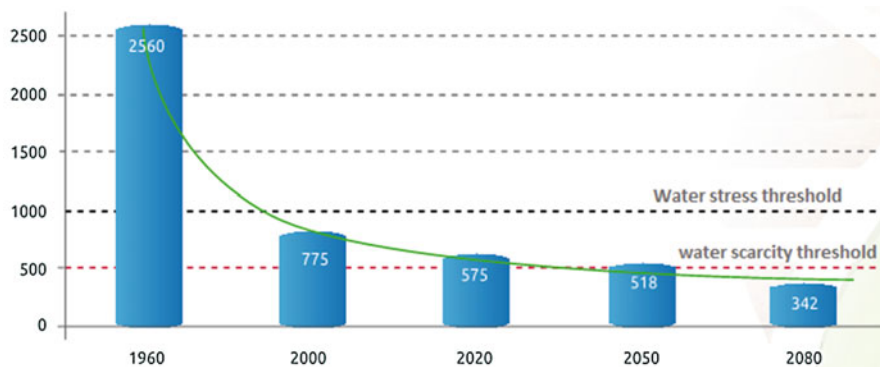
The adaptation is a process allowing improving, developing, and implementing strategies to mitigate the consequences of climatic events, to cope and to take advantage.

- Participatory approach: associate all communities and socio-professional categories capable to suffer the consequences of climate change
- Proactive approach: situations of crisis, so far as it is possible
- Optics of sustainable development
- Adaptation of infrastructure
- Use of nonconventional water resources

Currently, Morocco has 144 large dams and 13 others under construction. As part of a National Water Plan by 2030 and to meet the water needs of the population to avoid an imbalance between demand and supply by 2030, Morocco will realize close

**Table 1** Projection of capita m<sup>3</sup>/inhabitant/year (Sinan and Belhouji 2016)

Year	Optimistic scenario	Pessimistic scenario
1960	2560	2560
2000	775	775
2020	575	569
2050	518	464
2080	342	217



**Fig. 18** Water capital projection (m<sup>3</sup>/inhabitant/year) optimistic scenario (Sinan and Belhouji 2016)

to 1000 small dams and dams in different regions of Morocco between 2019 and 2026 (Plan National de l'Eau, horizon 2030).

### **Nonconventional Water Resources**

#### **(a) Reuse of Treated Wastewater:**

According to the national water plan for 2030, the potential of waters that can be reused by 2030 is around 325 million m<sup>3</sup>/year. This volume constitutes the potential of the usable water. To achieve these objectives, Morocco plans to carry out 162 projects in the watersheds of: Loukkos, Moulouya, Sebou, Bou Regreg Chaouia, Oum Er Rabiï, Tensift, Souss Massa Drâa, Guir Ziz Rhéris, and Sakia El Amra Oued Eddahab.

#### **(b) Desalination**

Desalination of seawater is an alternative For Morocco. Morocco is using since 1990 the desalination of seawater including the establishment of a station in 1995. This unit has a production capacity of 7000 m<sup>3</sup>/day of drinking water. In order to develop this sector, the government implements in Agadir another desalination station of 80,000 m<sup>3</sup>/day, which should be operational in 2010. In addition, in view of saving water, the study suggests to “fight against failures in water networks and water distribution, to raise awareness on water scarcity and promote the use of plants resistant to water stress.” Because, the study conducted by the High Commissioner for Planning shows that Morocco loses 1.3 billion per year including 1.1 billion m<sup>3</sup> in agriculture and 200 million m<sup>3</sup> in the drinking water and industrial sector.

A seawater desalination plant will be built in the Agadir region. It will be powered by solar energy, so it is a 100% ecological process in terms of renewable energy. Ultimately, it plans to produce about 275,000 cubic meters of water per day, of which 150,000 will be dedicated to human use and 125,000 to be used for irrigation of the 13,600 hectares of plantations in the southwest of the Kingdom, the maximum production capacity being 450,000 m<sup>3</sup> per day.

---

## **Recommendations**

According to the national water plan for 2030 of Kingdom of Morocco and to ensure the balance between supply and demand, the following operations will be carried out:

- The increase to 80% of the national average of the efficiency of drinking water distribution networks by 2025.
- The maintenance of the same level until the year 2030 and the search and repair of leaks, which will reduce the demand for drinking water by about 120 million m<sup>3</sup> per year by 2025.
- Saving water in irrigation by transforming traditional irrigation systems to local irrigation system (drip system) at a rate of 50,000 ha per year and saving 4.1



billion m<sup>3</sup> by 2020, and as part of the Green Morocco plan, efforts will be made to save an additional 3.2 billion m<sup>3</sup> by 2030.

- The construction of fourteen dams in progress, a further 35 are planned, in addition to the use of non-traditional water resources, such as the desalination of seawater at a rate of 510 million m<sup>3</sup> and the reuse of 325 million m<sup>3</sup> of wastewater after purification (Plan national water supply by 2030)
- The World Bank (2017) indicates that 35% of potential water resources are wasted, which requires a new strategy to preserve this resource.
- The National Water Plan provides, to meet the demand for water by 2030, an investment of 220 billion DH by 2030, which will be used among others to the construction of 3 dams per year.
- Develop integrated management of water resources by basin.

---

## Tunisia

### Water Potential and Climate Change

Tunisia has about 4766 million m<sup>3</sup> of exploitable resources for the year 2017, the equivalent of 450m<sup>3</sup>/year/inhabitant for all uses combined. The water mobilized in Tunisia is divided into surface waters (55%) 2630 Mm<sup>3</sup> and groundwater (45%) 2136 Mm<sup>3</sup>. Also, it should be noted that 88% of groundwater has salinity greater than 3 g/liter (Lahacher and Pillet 2008). Water resources in Tunisia are distributed as follows: 80% for irrigation, 14% for water drinking, and 6% for industry and tourism (SIGMA 2017). Tunisia had 17 dams before 1990. It built 20 dams during the first ten-year plan between 1990 and 2000. Then, during the 2nd ten-year plan from 2001 to 2011, Tunisia made 10 dams. The current total capacity of the 33 dams is 1.8 Mm<sup>3</sup> in 2018 according to the Ministry of Agriculture. The 253 collinear dams have a total capacity of 266 Mm<sup>3</sup> (Ouasli 2015). The 893 collinear lakes have a total capacity of 93 Mm<sup>3</sup>. Groundwater is produced by 138,000 shallow wells and 5400 deep wells (SIGMA 2017). The mobilization of water resources is about 95% of available water resources (Ouasli 2015).

By studying the evolution of the contributions to the main dams over the period from 1947 to 2004, two main conclusions can be distinguished (TSNCUNFCCC 2013):

- The contributions decrease by 27% during the period from 1976 to 2004 compared to the period 1947 to 1975.
- Contributions at the level of the northern dams during the period from 1976 to 2004, on the other hand, are 21% higher than the current average inputs.

Tunisia is located in the category of the least endowed countries with water resources in the Mediterranean. Indeed, for a population of 10 million inhabitants, the average allocation per capita per year is estimated at 450 m<sup>3</sup>. This figure will

decrease gradually to 350 m<sup>3</sup> per capita in 2030 for a population of 12 million inhabitants (Hamza 2007).

The surface water resources are highly variable in time and space. The average interannual surface water inflow is estimated at 2.7 billion m<sup>3</sup> per year (55.5%), 80% are from northern regions of Tunisia (Elloumi 2016). The groundwater resources are estimated, annual averages, about 2165 billion m<sup>3</sup> (45.5%) (Elloumi 2016). The volume of water mobilized in 2015 reached 4.6 mm (98%) (Elloumi 2016).

The increase in temperatures would vary between 0.8 and 1.3 °C in 2020 and 2.1 °C in 2050 with the decrease of rainfall by 10 to 30%, the loss of 28% of conventional water resources, and 20% of arable land by 2030.

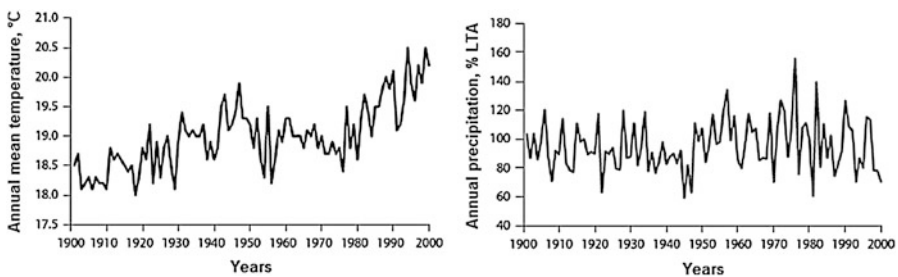
Nouaceur (2016) divided the rainfall trend for Tunisia into three periods:

- From 1970 to 1986, an absence of trend. This period is characterized by an important variation of the extreme years.
- The second period (1987–2003) is marked by a dry trend that lasts 16 years. The years of the dry and very dry class totaled 55% of the observations for all the stations.
- The third period (2003–2013) is described as wet. The wet and very humid years total almost 48% while the dry and very dry years 31.3%.

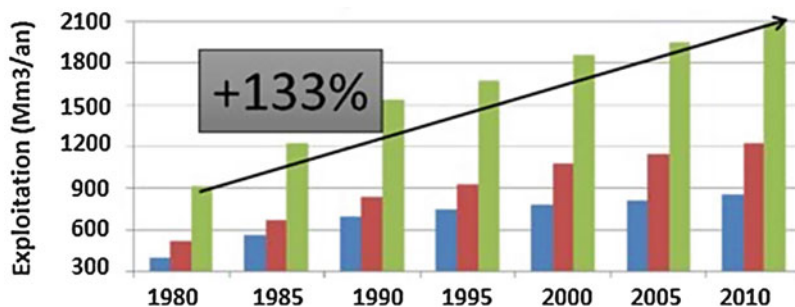
Climatic data show that average annual temperatures have increased by about 1.4 °C during the twentieth century, where the warmest temperatures have been recorded since the 1970s. Local warming rates may be higher, for example, in Tunis, temperatures rose by around 3 °C during the twentieth century (World Bank 2013). Annual totals of rainfall have decreased by 5 percent per decade in northern Tunisia since the 1950s (Fig. 19).

The study on the inflow to major dams during the period from 1947 to 2004 revealed two major conclusions: a decrease in discharge of the period 1976–2004 compared to the period 1947–1975 about 27% (Lahacher and Pillet 2008).

Deep and shallow aquifers exploitation increased by 333% and 228%, respectively, between 1968 and 2010. The largest increase occurred before the 1980s (Trabelsi 2016), Fig. 20.



**Fig. 19** Average temperatures of the twentieth century and precipitation in Tunisia (Mitchell et al. 2002)



**Fig. 20** Evolution of the groundwater exploitation in Tunisia in  $\text{Mm}^3/\text{year}$  (Trabelsi 2016)

The droughts will result from the intensive exploitation of groundwater. The simulation based on the historical evolution of the quality of groundwater resources has led to a decrease of the exploitable groundwater potential equal to  $467 \text{ m}^3$  in 2030. This quantity corresponds to the volume of water currently overexploited. For deep waters, the reduction will be 517 million  $\text{m}^3$ . The exploitation of deep groundwater will require more energy to pump water (Lahacher and Pillet 2008).

The pressure on water resources will be major. Groundwater, coastal, non-renewable aquifers will decline from 28% in 2030, surface water will decrease by 5% on the same horizon, and the summer rainfall will increase the lack of soil moisture (Sarra 2009).

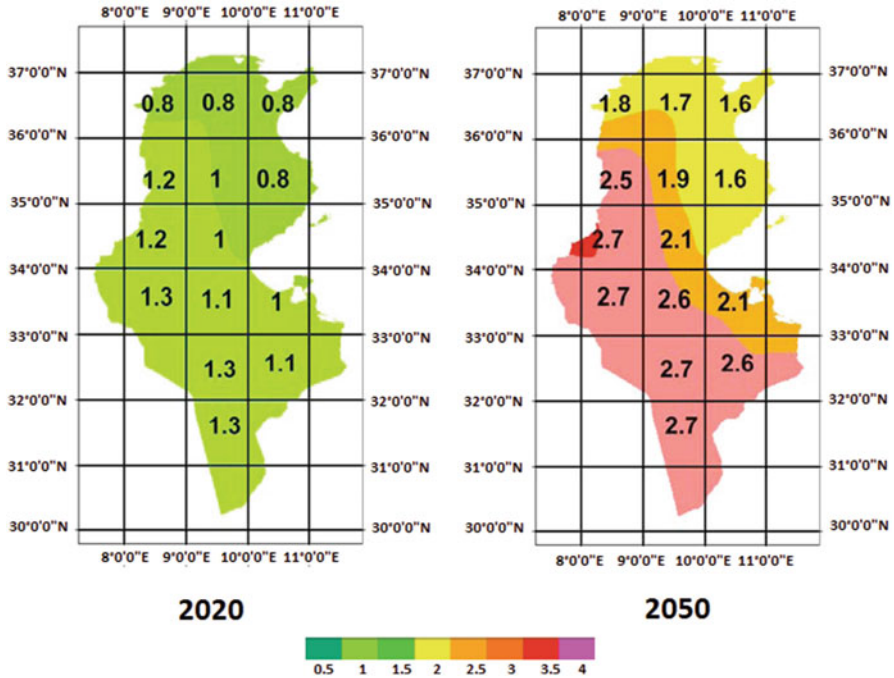
## Future Projections

The projections from the HadCM3 model, according to the A2 scenario, show an increase in mean temperature of  $1.1 \text{ }^\circ\text{C}$  by 2020 and  $2.1 \text{ }^\circ\text{C}$  by 2050 compared to the 1961–1990 reference period. The largest increases will be in the South, with  $1.3 \text{ }^\circ\text{C}$  by 2020 and  $2.7 \text{ }^\circ\text{C}$  by 2050 (TSNCUNFCCC 2013). By 2100, projections of average monthly temperatures show a stronger upward trend over almost regions, the expected increase in temperature is above  $2 \text{ }^\circ\text{C}$  (Fig. 21). The maximum is expected in the region of Gafsa in southern Tunisia with an increase of  $3.91 \text{ }^\circ\text{C}$  (Ouasli 2015).

Dry years will become more frequent and intense by 2030, and extremely dry and wet seasons will vary from season to season (TSNCUNFCCC 2013).

The HadCM3 projections for the A2 scenario show a general decrease in average precipitation. This reduction is relatively moderate by 2020 but will become significant by 2050. In 2020, the decrease in annual rainfall varies between  $-5\%$  in the north and  $-10\%$  in the extreme south (TSNCUNFCCC 2013).

The decrease in rainfall varies between  $(-10\%)$  in the northwest and  $(-30\%)$  in the extreme south of Tunisia by 2050. Three regions can be distinguished: the extreme west of the country is characterized by a slight decrease in the order of  $(-10\%)$ , the south with a significant decrease of about  $(-29\%)$  compared to the third



**Fig. 21** Temperature (°C) average annual increases in the HadCM3 model (A2 scenario) compared to the reference period in 2020 and 2050 (MARH 2007)

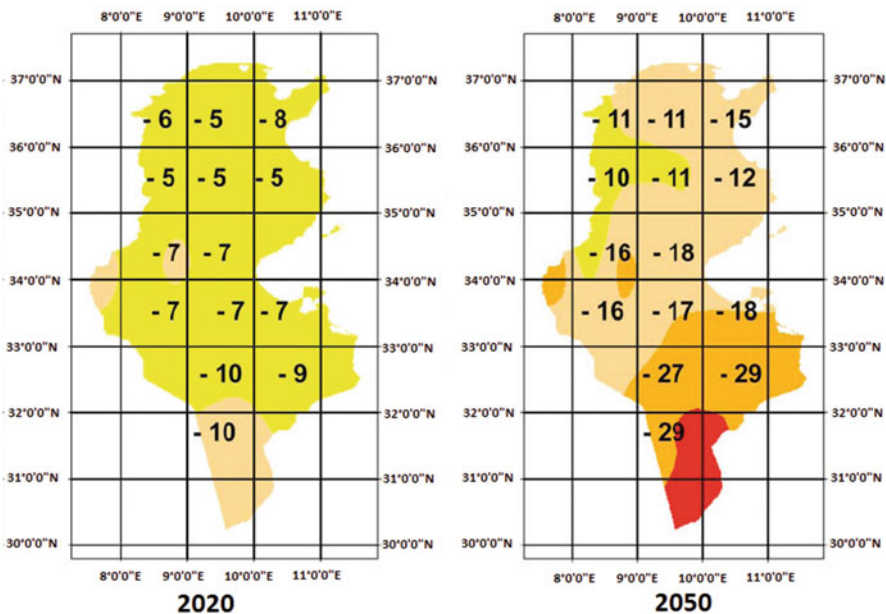
region which includes the rest of the country where the reduction varies between -12% and -16% (TSNCUNFCCC 2013) (Fig. 22).

For seasonal changes by 2020, the lowest reduction in precipitation will be recorded in winter (0% to -7%). The largest drop from -8% to -40% will occupy the space from north to extreme south in summer (TSNCUNFCCC 2013).

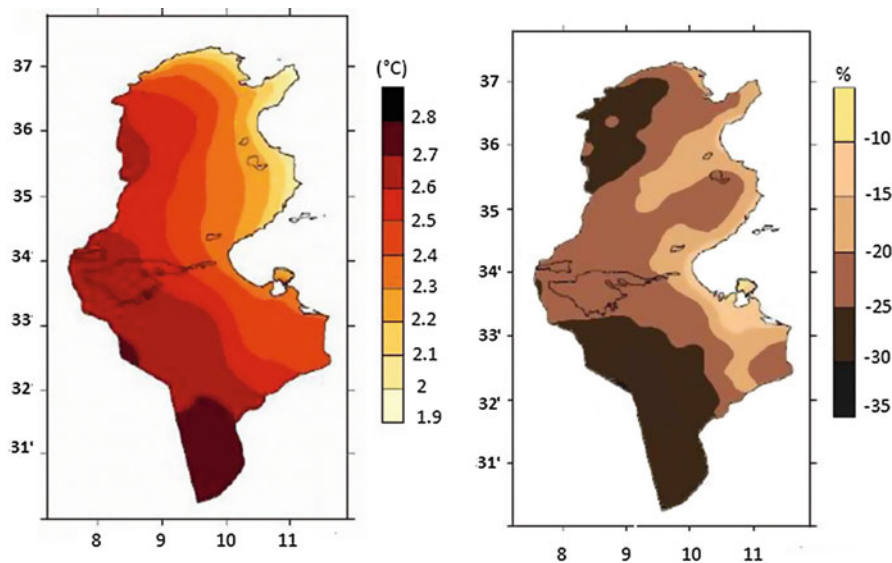
The situation in autumn and spring is intermediate with rainfall decreasing from -6% to -12% in the extreme south. Seasonal changes are about the same by 2050 (TSNCUNFCCC 2013).

By 2100, future trends in monthly average rainfall are down for all Tunisia (Fig. 23). The maximum decrease is for the Sfax station, located in North East Tunisia, with a percentage of 78.23%. Projections show a strong gradient between trends in the north and those in the south (Ouasli 2015).

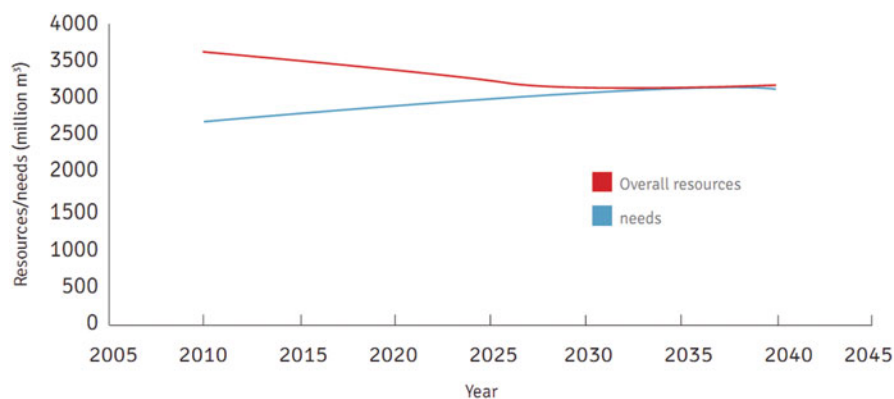
Climate projection models show that conventional water resources will decrease by about 28% by 2030. This decrease will mainly concern shallow groundwater with high salinity, coastal aquifers, and nonrenewable aquifers. In particular, the reduction of surface water reserves will be around 5% by 2030. The confrontation between the available water resources and the increasing demand for water shows that this demand will not be satisfied by 2030 (Fig. 24) without the implementation of more effective conservation and water saving strategies as well as water infrastructure development programs (MARH 2007). Projections of average monthly rainfall



**Fig. 22** Decreases of the average annual rainfall in % of the HadCM3 model (A2 scenario) compared to the reference period by 2020 and by 2050 (GTZ 2007)



**Fig. 23** Projection of temperature and rainfall by 2100 (INM in Ouasli 2015)



**Fig. 24** Evolution (in million m<sup>3</sup>) of overall water resources (in blue) and needs for water (in red) in Tunisia taking into account climate change impacts on water resources (MARH 2007)

over Tunisia show the future evolution of aridity and mark its trend to the north of Tunisia which shows the vulnerability of the south to water stress in the future (Ouasli 2015).

Recent climate projections confirm the reduction of piezometric levels of the aquifer in the Sfax region located in southeast of Tunisia by 2020 and 2050 for the following two scenarios (Boughariou et al. 2018): the first considers a constant and increasing consumption, the second integrates climate projections published by the Tunisian Ministry of Agriculture and Water Resources and the German Agency for International Cooperation (GIZ), using HadCM3 as a model for general circulation (Boughariou et al. 2018). Both scenarios also indicate the quantitative degradation of the groundwater by 2050 with an alarming marine intrusion (Boughariou et al. 2018).

The projection of water resources, on the basis of various hypotheses proposed, shows that the exploitable conventional water resources will be around 3,829 million m<sup>3</sup> in 2030, given that the water management program is carried out entirely (high hypothesis), of 3170 Mm<sup>3</sup> in the case where only a part of the program will be realized (average hypothesis) and 2718 Mm<sup>3</sup> and in the case where the program will not be realized (hypothesis low) (TSNCUNFCCC 2013).

The addition of unconventional water resources will strengthen the exploitable resources. This is the desalination of seawater (80 Mm<sup>3</sup> in the year 2030) and the reuse of treated wastewater (292 Mm<sup>3</sup>) for agricultural needs. The total exploitable in Tunisia in 2030 will be around 4,201 Mm<sup>3</sup> (TSNCUNFCCC 2013).

Total water requirements by 2030 are projected at about 2911 Mm<sup>3</sup> in the case of the low assumption, 3,054 Mm<sup>3</sup> for the medium hypothesis and 3,743 Mm<sup>3</sup> for the high hypothesis. Needs-side assumptions are also defined based on the rate of achievement of the projected programs (TSNCUNFCCC 2013).

In the case where all programs for water mobilization are carried out, the projected needs can be met by 2030 (an excess of about 11% of the available amount is planned, Table 2). In the case where the planned programs are not all realized, a

**Table 2** Evolutions of water resources considering climate change (in millions of m<sup>3</sup>)

Designation	2010				2020				2030			
	Potential	Mobilized	Exploitable	Potential	Mobilized	Exploitable	Potential	Mobilized	Exploitable	Potential	Mobilized	Exploitable
Dams	2700	2121	1378	2700	2131	1385	2700	1890	1229			
Groundwater	758	758	758	781	781	591	805	805	308			
Deep aquifers	1544	1350	1350	1791	1535	1215	2079	1731	1214			
Total conventional waters	5002	4229	3486	5272	2447	3191	5584	4426	2751			
Treated wastewater	253	117	117	400	203	203	512	372	372			
Desalted waters		18	18	0	47	47	0	80	80			
Total non-conventional waters	253	117	117	400	203	203	512	372	372			
Total	5255	4336	3603	5672	4650	3394	4798	4798	3123			

Source: Ministry of Agriculture and Water Resources (MARH 2007)

lack of water is likely to appear from 2022 (and this, even if the low hypothesis of the needs side is retained) (TSNCUNFCCC 2013).

If water needs do not evolve as planned and programs to increase the availability of the resource are not realized (low hypothesis), the difference between needs and available water resources would be negative by 2015 (TSNCUNFCCC 2013).

The vulnerability of conventional water resources to climate change in Tunisia is characterized by (Ouasli 2015):

- A reduction of these resources by around 28% by 2030. The decrease will affect groundwater, coastal water, and nonrenewable groundwater.
- Increasing frequencies of extreme events: drought and flood.
- The reduction of water volumes in dams by around 5% by 2030.
- A deterioration of the quality of surface and underground waters.
- The succession of extreme events: floods and drought.
- The succession of periods of drought. These periods will have an impact on the natural recharge of groundwater. These aquifers will be exposed to over-exploitation to compensate the deficit in surface water for irrigation.

## Adaptation

### Water Saving Measures

The main threats to water resources are:

- The overuse of groundwater resources
- Pollution of water resources (rivers, groundwater, etc.). Discharges by solids or liquids into the environment, rivers, and vulnerable groundwater
- The silting of reservoirs
- The incidence of successive dry years that hinder the annual renewal of water resources
- Water wastage and losses
- The impact of climate change

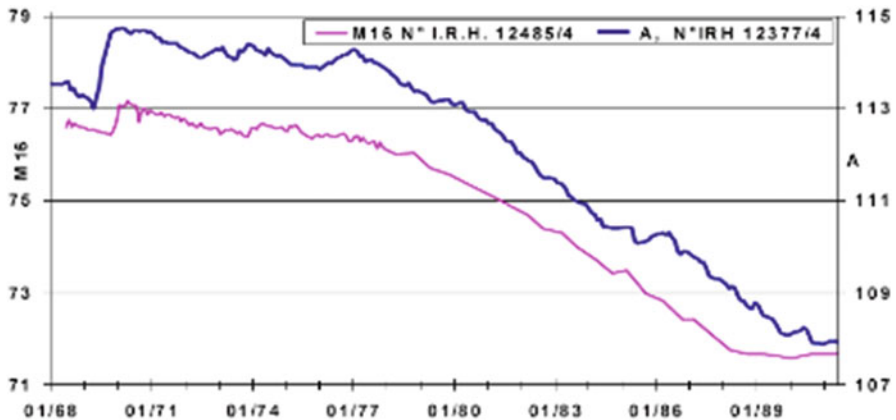
It was recorded around 20 droughts during the twentieth century. During this period a severe drought is recorded every 6 years.

During the years 1987, 1988, and 1989, Tunisia has experienced the most critical drought. It led to a water deficit around 30%.

In case of drought, the agricultural sector, which currently consumes 81% of water resources, will suffer water shortages which will result in an increased use of groundwater and can have dramatic effects, since these resources contribute to maximum of 82% to the satisfaction of agricultural needs (Fig. 25).

To overcome the lack of water in the future, the below directions are to be followed:





**Fig. 25** Decrease of the level of aquifer Merguellil (central Tunisia)

- Complete the implementation of works to mobilize water resources to achieve a mobilization rate of 95%
- Integrated management of water resources by capitalizing excess of wet years in order to reduce the effects of drought
- The water conservation and demand management in all sectors
- The use of wastewater in agriculture
- The use of desalination water for drinking water
- The protection of water resources against pollution
- The protection of groundwater against overexploitation (Fig. 25)

The presidential program “Let us rise to the challenges 2009–2014” provides for an increase of 30% currently to 50% in 2014 the exploitation rate of treated wastewater in agriculture, industry, and tourism.

Large areas of around 8,500 ha of irrigated crops with treated wastewater will be built within this framework, in the Greater Tunis, Zaghouan, Beja, Sousse, Kairouan, Sfax, Gafsa, Kébili, Gabes, and Tataouine Medenine.

Meanwhile, the authorities will consider the study of potentialities for food, with unconventional resources, groundwater, notably those excessively exploited.

The desalination of water in the majority belongs to the SONEDE for a total capacity of 95,000 m<sup>3</sup> (Lahacher and Pillet 2008). Desalination of water is being expanded especially in the tourism sector. New desalination installations based on sea water are programmed by SONEDE in Djerba, Sfax, and Zarrat for a total potential of about 80 m<sup>3</sup> in 2030.

## Recommendations

The following proposed measures may be the best way to cover future water demand (Ouasi 2015; Ben Nouna et al. 2018):

- Improve the consideration of ecosystems: necessary to ensure adequate recharge of aquifers for the production of good quality of water
- Improvement of water demand management and strengthening of the National Water Saving Program especially water saving for irrigation
- Develop a strategic policy regarding the prediction of extreme events, raising of dams to safeguard their capacity, encouraging the practice of less water-consuming crops
- Quantify the processes of water erosion and siltation rates of dams
- Control of energy consumption during the production of water (pumping, desalination) using clean energies (solar for example)
- Develop integrated management of water resources by basin
- Involve farmers so that they can participate in the future of their water resources
- Enhance knowledge and experience in the field of traditional hydraulic systems
- To further develop the artificial recharge of groundwater
- Development of scientific research related to the water sector

---

## Conclusion

According to recent studies, the Maghreb countries will become hotspots by the end of the twenty-first century. Higher temperatures and reduced rainfall will increase the frequency of droughts in these countries. The drought observed in recent decades has tragic consequences. These effects are reflected by lower inflows to dams with more than 30% reduction in dam volumes and the lower level of groundwater sometimes with 40 m of drawdown in the plain of Mitidja in Algeria for example. This latter is the combined effect of drought and overexploitation of groundwater. This overexploitation is due to the decrease of the natural recharge and the increase of the water demand (Increasing demography and economic and social development).

The decrease in rainfall, as the lag time of rainy seasons, has penalized development projects particularly related to agriculture and affect the proper functioning of the carried out infrastructure.

To mitigate the impacts of climate change in the region, we recommend the integration of climate change in the programs and policies particularly in the context of sustainable development. It must also take into account the weather, and reinforce the measures of Weather assistance in the rural areas and to all users.

The undeniable effects of drought on reducing the level of production of cereals in particular require from planners to take into account the continuing risks associated with an arid climate and the risks of seasonal drought in all aspects of agricultural development. Thus the long dry season causes prolonged water stress to be taken into account in the selection of appropriate crops and varieties.

For the three countries, many projects and programs are developed and implemented to cope with the effects of climate change and Anthropoc. These countries are also facing rapid population growth and sustained socioeconomic development. Agriculture is the cornerstone of this development, which will increase the demand for water. The water infrastructure programs must take into account this strategy which will ensure the food security of these three Maghreb countries.

In order to meet this ever increasing demand for water, especially for agriculture, it is necessary to set up special programs and develop irrigation techniques to reduce the consumption of water resources in agriculture. These programs should also make it possible to increase agricultural production to ensure food security in these three countries. Also, the reduction of water leakage from drinking water supply networks that are important in the order of 30 to 40%. The fight against water scourge makes it possible to create new irrigated perimeters and to effectively supply the population with drinking water.

---

## References

- Agoumi A (2003) Vulnérabilité des pays du Maghreb face aux changements climatiques. International Institute for Sustainable Development (IISD), Winnipeg. 11 p
- Alaoui M (2013) Water sector in Morocco: situation and perspectives. *J Water Resour Ocean Sci* 2 (5):108–114
- Ameur F (2017) Construction de la surexploitation et reproduction des inégalités d'accès et d'usage des eaux souterraines. Thèse de doctorat. AgroParisTech, France.
- Amraoui F (2019) Integrated management of water resources as a response to the water deficit: Case of the Saiss Plain (Morocco). International conference “groundwater resilience to climate change and high pressure” GRECPIMA 2019. May -8-10, 2019, Muğla, Turkey
- Bct (2007) Rapport annuel de la banque centrale de Tunisie. Ministère du Développement et de la Coopération Internationale de Tunisie. 70 p. [https://www.apbt.org.tn/wp-content/uploads/2016/06/rapport\\_fran\\_2007\\_t1.pdf](https://www.apbt.org.tn/wp-content/uploads/2016/06/rapport_fran_2007_t1.pdf)
- Ben Abdelfadel A, Driouech F (2008) Climate change and its impacts on water resources in the Maghreb region. 13ème Congrès Mondial de l'Eau, 1–4 septembre, Montpellier, France
- Ben Nouna B, Rezig KS, Chebil A, Jebari S (2018) Water resources and climate change: key adaptation strategies and the role of scientific research in Tunisia. *J New Sci Agricult Biotechnol* 51(1):3138–33147
- Boughariou E, Allouche N, Jmal I, Mokadem N, Ayed B, Hajji S, Khanfir H, Bouri S (2018) Modeling aquifer behaviour under climate change and high consumption: Case study of the Sfax region, southeast Tunisia. *J Afr Earth Sci* 141:118–129. <https://doi.org/10.1016/j.jafrearsci.2018.02.006>
- Chebil A, Souissi A, Frija A, Stambouli T (2019) Estimation of the economic loss due to irrigation water use inefficiency in Tunisia. *Environ Sci Pollut Res* 26:11261–11268. <https://doi.org/10.1007/s11356-019-04566-8>
- Choukr-Allah R. Comparative study between Moroccan water strategies and WFD. In: Junier S, El Moujabber M, Trisorio-Liuzzi G, Tigrek S, Serneguet M, Choukr-Allah R, Shatanawi M, Rodríguez R (eds) *Dialogues on Mediterranean water challenges: Rational water use, water price versus value and lessons learned from the European Water Framework Directive*. Bari : CIHEAM, 2011. p. 181–188 (Options Méditerranéennes : Série A. Séminaires Méditerranéens; n. 98)
- Dahan S (2017) Managing urban water scarcity in Morocco. World Bank, Washington, DC
- Demmak A (2008) La sécheresse en Algérie des années 1975/2000. Second meda water regional event on local water management, Marrakech, morocco, 28, 29 & 30 April 2008
- Driouech F (2010) Distribution des précipitations hivernales sur le Maroc dans le cadre d'un changement climatique: Descente d'échelle et incertitudes. PhD thesis University of Toulouse (France), 163 p
- Droogers P, Immerzeel W W, Terink W, Hoogeveen J, Bierkens MFP, Van Beek LPH, Debele B (2012). Water resources trends in Middle East and North Africa towards 2050. *Hydrol Earth Syst Sci*, 16, 3101–3114., <http://www.hydrol-earth-syst-sci.net/16/3101/2012/>. <https://doi.org/10.5194/hess-16-3101-2012>

- El Hafid D, Zzerrouqi Z, Akdim B (2017) Study of drought sequences in the Isly basin (East Morocco). *Larhyss J* 31:83–94
- Elloumi F (2016) La gouvernance des eaux souterraines en Tunisie. IWMI projectreport n°7. Groundwater governance in the Arab World. 2016. 121 p
- Farzaneh MR, Eslamian S, Mirnezami SJE (2014) Chap 8 Climate change: uncertainty, impact, and adaptation. In: Eslamian S (ed) *Handbook of engineering hydrology*, Vol. 2: modeling, climate changes and variability. Francis and Taylor, CRC Group, Boca Raton, pp 127–146
- Giorgi F (2002) Variability and trends of sub-continental scale surface climate in the twentieth century. Part I: observations. *Clim Dyn* 18:675–691. <https://doi.org/10.1007/s00382-001-0204-x>
- GTZ (2007) Stratégie Nationale d'Adaptation de l'Agriculture Tunisienne et des écosystèmes aux changements climatiques. Deutsche Gesellschaft für Internationale Zusammenarbeit (GIZ) GmbH. 150 p. <http://www.environnement.gov.tn/PICC/wp-content/uploads/Strat%C3%A9gie-nationale-d%E2%80%99adaptation-de-l%E2%80%99agriculture.pdf>
- Habibi B, Meddi M, Torfs PJFF, Remaoun M, Van Lanen HAJ (2018) Characterisation and prediction of meteorological drought using stochastic models in the semi-arid Chéiff-Zahrez basin (Algeria). *J Hydrol Reg Stud* 16:15–31. <https://doi.org/10.1016/j.ejrh.2018.02.005G>
- Haddour A, Mahé G, Meddi M (2019) Impact des changements climatiques sur la ressource en eau dans trois grands bassins versants du centre et de l'ouest de l'Algérie. Séminaire international sur l'hydrogéologie et l'environnement. 12–14 mars 2019, Ouargla (Algérie)
- Hallouz F, Meddi M, Mahe G (2013) Modification du régime hydroclimatique dans le bassin de l'oued mina (nord-ouest d'Algérie) – changes of the hydroclimatic regime in the basin of the Wadi mina (northwestAlgeria). *Revue des Sciences de l'Eau* 26(1):33–38. <https://doi.org/10.7202/1014917ar>
- Hamza M (2007) Gestion des ressources en eau en Tunisie. ineco- Nabeul, le 6 décembre 2007. <http://environ.chemeng.ntua.gr/ineco/UserFiles/File/TunisiaWorkshop/Gestion%20des%20ressources%20en%20eau%20en%20Tunisie.pdf>
- INDC (2015) Morocco's intended nationally determined contribution, 36 p. <https://www4.unfccc.int/sites/submissions/INDC/Published%20Documents/Morocco/1/Morocco%20INDC%20submitted%20to%20UNFCCC%20-%205%20june%202015.pdf>
- IPCC (2013) Summary for policymakers. In: Stocker TF, Qin D, Plattner G-K, Tignor M, Allen SK, Boschung J, Nauels A, Xia Y, Bex V, Midgley PM (eds) *Climate change 2013: the physical science basis*. Contribution of working group I to the fifth assessment report of the intergovernmental panel on climate change. Cambridge University Press, Cambridge/New York, pp 3–30
- Jacobeit J (2000) Rezente Klimaentwicklung im Mittelmeerraum. *Petermanns Geogr Mitt* 144:22–33
- Kahlerras M, Meddi M, Benabdelmalek M, Tumi S, Kahlerras D, Nouiri I (2018) Modeling water supply and demand for effective water management allocation in Mazafran basin (north of Algeria). *Arab J Geosci* 11(18):1–12
- Khomsi K, Mahe G, Sinan M, Snoussi M (2013) Hydro-climatic variability in two Moroccan watersheds: a comparative analysis of temperature, rain and flow regimes. In: Boegh E, Blyth E, Hannah DM, Hisdal H, Kunstmann H, Su B, Yilmaz KK (eds) *Climate and land surface changes in hydrology*, vol 359. IAHS Publications, Wallingford, pp 183–190
- Knippertz P, Christoph M, Speth P (2003) Long-term precipitation variability in Morocco and the link to the large-scale circulation in recent and future climates. *Meteorog Atmos Phys* 83:67–88. <https://doi.org/10.1007/s00703-002-0561-y>
- Lahacher RG, Pillet G (2008) Projection des ressources en eau de la Tunisie sous les effets des changements climatiques globaux. XIIIth World Water Congress, 1–4 septembre, Montpellier, France
- MARH (2007) (Ministère de l'Agriculture et des Rein climate change 2013 ssources Hydrauliques de Tunisie). Stratégie Nationale d'Adaptation de l'Agriculture Tunisienne et des écosystèmes aux changements climatiques. Bureaux d'études GOPA et Exa Consult Tunisie, janvier 2007. 150 p
- Matari A (2016) Climat et changement climatique. *Journal Algérien des Régions Arides (jara)*, Numéro Spécial, 2016

- MDCE (2016) Troisième communication Nationale du Maroc à la convention cadre des nations unies sur le changement climatique. Ministère Délégué Auprès du Ministère de l'Énergie, des Mines, de l'Eau et de l'Environnement Chargé de l'Environnement, Avril 2016. <https://unfccc.int/resource/docs/natc/maroc3.pdf>
- Meddi M, Boucefiane A (2009) Impact of Climate Change on the renewal of underground water resources (Case Hydrographic Basin Chélif-Zahrez). Groundwater and Climate in Africa (Proceedings of the Kampala Conference, June 2008). IAHS Publication, 334
- Meddi M, Hubert P (2003) Impact de la modification du régime pluviométrique sur les ressources en eau du Nord-ouest de l'Algérie. In: Servat E, et al., eds. Hydrology of Mediterranean and semi-arid regions. Wallingford: IAHS Press, IAHS. Publ. 278, 229–235. Disponible à: [http://iahs.info/redbooks/a278/iahs\\_278\\_229.pdf](http://iahs.info/redbooks/a278/iahs_278_229.pdf)
- Merabti M, Martins DM, Meddi M, Pereira IS (2018) Spatial and time variability of drought based on SPI and RDI with various time scales. *Water Resour Manag* 32:1087–1100. <https://doi.org/10.1007/s11269-017-1856-6>
- Mitchell TD, Hulme M, New M (2002) Climate data for political areas. *Area* 34:109–112. <http://www.cru.uea.ac.uk/timm/data/index-table.html>
- New M, Todd M, Hulme M, Jones P (2001) Precipitation measurements and trends in the twentieth century. *Int J Climatol* 21:1899–1922
- Nouaceur Z (2016). Analyse de la variabilité pluviométrique sur près d'un demi-siècle au Maghreb central (Maroc, Algérie, Tunisie). XXIXe Colloque de l'Association Internationale de Climatologie, Lausanne – Besançon
- OSS (2009) Vers un système d'alerte précoce à la sécheresse dans 3 pays de la rive sud de la Méditerranée. Collection de Synthèse n°4. OSS – Tunis 2009. 86 p. [http://www.oss-online.org/cd\\_envi/doc/07/03/06.pdf](http://www.oss-online.org/cd_envi/doc/07/03/06.pdf)
- Ouasli A (2015) Secteur de l'eau en face des changements climatiques (cc). Forum scientifique "innovation dans le secteur agricole et le défi du changement climatique". Bureau de Planification et des Equilibres Hydrauliques. République Tunisienne, Ministère de l'Agriculture, des Ressources Hydrauliques et de la Pêche. <http://www.siat.tn/medias/files/siat-2016/interventions/2-2-Secteur-de-l-Eau.pdf>
- Rodrigo FS, Trigo RM (2007) Trends in daily rainfall the Iberian Peninsula from 1951 to 2002. *Int J Climatol* 27:513–529
- Sarra A (2009) Projections, impacts et stratégies d'adaptation. <https://www.webmanagercenter.com/2009/08/26/79540/tunisie-changement-climatique-projections-impacts-et-strategies-d-adaptation-3-3/>
- SCNCCRM (2009) Seconde Communication Nationale à la Convention Cadre des Nations Unies sur les changements climatiques du royaume du Maroc. Ministère de l'Aménagement du Territoire, de l'Urbanisme, de l'Habitat et de l'environnement, 2009. 217 p
- SIGMA (2017) L'eau en Tunisie entre enjeux stratégiques et qualité de vie des citoyens. Les rencontres de Tunis, Conférence – débat. 28 septembre 2017
- Sinan M, Belhouji A (2016) Impact of the climate change on the climate and the water resources of Morocco on horizons 2020, 2050 and 2080 and measures of adaptation. *La Houille Blanche* 4:32–39
- Sinan M, Boussetta M, El Rherari A (2009). Changement climatique: causes et conséquences sur le climat et les ressources en eau. *J HTE* 142 21–30
- Taabni M, El Jihad MD (2015) Eau et changement climatique au Maghreb: quelles stratégies d'adaptation? *Les Cahiers d'outre-Mer* 65(260):493–518
- Trabelsi F (2016) Impact du changement climatique sur les ressources en eau souterraine et politiques d'adaptation en Tunisie. Project: Tempus IV: Building Climate Change Adaptation in Morocco, Algeria and Tunisia "Climadapt"
- Trambay Y, El Adlouni S, Servat E (2013) Trends and variability in extreme precipitation indices over Maghreb countries. *Nat Hazards Earth Syst Sci* 13:3235–3248. <https://doi.org/10.5194/nhess-13-3235-2013>
- TSNCUNFCCC (2013) Tunisia's second national communication under the United Nations framework convention on climate change (UNFCCC). 174 p., 2013. <http://www.unfccc.int/resource/docs/natc/tunnc2.pdf>

- World Bank (2013) La Tunisie face aux changements climatiques. Évaluation et Actions pour accroître la résilience et le développement. 2010. 174 p
- World Bank (2017) Beyond scarcity: Water security in the Middle East and North Africa. MENA development report. World Bank, Washington, DC. Licence: CC BY 3.0 IGO <https://openknowledge.worldbank.org/handle/10986/27659>
- World Bank Group (2017a) Climate variability, drought, and drought management in Morocco's agricultural sector in Morocco. <http://documents.worldbank.org/curated/en/353801538414553978/Climate-Variability-Drought-and-Drought-Management-in-Morocco-Agricultural-Sector>
- World Bank Group (2017b) Managing urban water scarcity in Morocco. World Bank, Washington, DC. © World Bank. <https://openknowledge.worldbank.org/handle/10986/29190>. License: CC BY 3.0 IGO
- Zeroual A (2017) Evolution du climat passé récent et futur en algérie. PhD thesis, ENSH, Blida, 2017, 250 p
- Zeroual A, Assani Ali A, Meddi M (2017) Combined analysis of temperature and rainfall variability as they relate to climate indices in northern Algeria over the 1972–2013 period. *Hydrol Res* 48(2):584–595

**Open Access** This chapter is licensed under the terms of the Creative Commons Attribution 4.0 International License (<http://creativecommons.org/licenses/by/4.0/>), which permits use, sharing, adaptation, distribution and reproduction in any medium or format, as long as you give appropriate credit to the original author(s) and the source, provide a link to the Creative Commons license and indicate if changes were made.

The images or other third party material in this chapter are included in the chapter's Creative Commons license, unless indicated otherwise in a credit line to the material. If material is not included in the chapter's Creative Commons license and your intended use is not permitted by statutory regulation or exceeds the permitted use, you will need to obtain permission directly from the copyright holder.





# Hydrological Dynamics Assessment of Basin Upstream–Downstream Linkages Under Seasonal Climate Variability **98**

Oseni Taiwo Amoo, Hammed Olabode Ojugbele,  
Abdultaofeek Abayomi, and Pushpendra Kumar Singh

## Contents

Introduction .....	2006
Background .....	2006
Procedural Summary .....	2010
Key Findings .....	2012
Seasonal Trend and Variability Changes among the Climatic Variables .....	2012
Factor Analysis (FA) Findings .....	2014
ANN Pattern Classifier and Flow Regime Variation .....	2014
Model Performance and Evaluation Measures .....	2016
Limitations of the Study .....	2019
Seasonal Coping and Adaption Strategies to Climate Variability .....	2020
Conclusion .....	2021
References .....	2021

---

This chapter was previously published non-open access with exclusive rights reserved by the Publisher. It has been changed retrospectively to open access under a CC BY 4.0 license and the copyright holder is “The Author(s)”. For further details, please see the license information at the end of the chapter.

---

O. T. Amoo (✉)

Risk and Vulnerabilty Science Centre, Walter Sasilu University , Eastern Cape, South Africa  
e-mail: [ejire36@gmail.com](mailto:ejire36@gmail.com)

H. O. Ojugbele

Regional and Local Economic Development Initiative, University of KwaZulu-Natal, Westville, South Africa

A. Abayomi

Department of Information and Communication Technology, Mangosuthu University of Technology, Umlazi, Durban, South Africa

P. K. Singh

Water Resources Systems Division, National Institute of Hydrology, Roorkee, India

© The Author(s) 2021

W. Leal Filho et al. (eds.), *African Handbook of Climate Change Adaptation*,  
[https://doi.org/10.1007/978-3-030-45106-6\\_116](https://doi.org/10.1007/978-3-030-45106-6_116)

2005

---

**Abstract**

The impacts of climate change are already being felt, not only in terms of increase in temperature but also in respect of inadequate water availability. The Mkomazi River Basins (MRB) of the KwaZulu-Natal region, South Africa serves as major source of water and thus a mainstay of livelihood for millions of people living downstream. It is in this context that the study investigates water flows abstraction from headwaters to floodplains and how the water resources are been impacted by seasonal climate variability. Artificial Neural Network (ANN) pattern classifier was utilized for the seasonal classification and subsequence hydrological flow regime prediction between the upstream–downstream anomalies. The ANN input hydroclimatic data analysis results covering the period 2008–2015 provides a likelihood forecast of high, near-median, or low streamflow. The results show that monthly mean water yield range is 28.6–36.0 m<sup>3</sup>/s over the Basin with a coefficient of correlation (CC) values of 0.75 at the validation stage. The yearly flow regime exhibits considerable changes with different magnitudes and patterns of increase and decrease in the climatic variables. No doubt, added activities and processes such as land-use change and managerial policies in upstream areas affect the spatial and temporal distribution of available water resources to downstream regions. The study has evolved an artificial neuron system thinking from conjunctive streamflow prediction toward sustainable water allocation planning for medium- and long-term purposes.

---

**Keywords**

Seasonal classifier · Climate variability · Sustainable water allocation · Artificial neuron network · System thinking

---

**Introduction****Background**

The seasonal hydrological flow regime is of utmost importance in understanding potential water allocation schemes and subsequent environmental standards flow regulation. Streamflow is a fundamental component of the water cycle and a major source of freshwater availability for humans, animals, plants, and natural ecosystems. It is severely being impacted upon by human activities and climate change variability (Makkeasorn et al. 2008; Null et al. 2010).

Climate change variability has a profound impact on water resources, biophysical, and socioeconomic systems as they are highly interconnected in complex ways (Graham et al. 2011; Null and Prudencio 2016). A change in any one of these induces a change in another. The effects of climate indices on streamflow predictability are seasonal and region dependent (Katz et al. 2002). Although, there are



different approaches to assess a basin response to climate variables change. Hydrologists have devised different approaches to investigate how water, the environment, and human activities are mutually dependent and interactive under various climatic conditions (Bayazit 2015). Most of the morphoclimatic challenge studies in any region are usually customized and basin specific. Though many studies have investigated the effects of changing temperature, precipitation, and evaporation as climate variables on water resources management (Katz 2013; Kundzewicz et al. 2008; Null and Prudencio 2016; Taylor et al. 2013), only few have examined seasonal fluctuations of water allocations in nonstationary climates and captured the hydrologic variability trend characterization based on different temporal scales on the whole catchment (Egüen et al. 2016; Gober 2018; Katz 2013; Poff 2018).

Topographic effects on rainfall vary seasonally due to the particular hydrologic process in the region which makes seasonal water allocation and varying environmental flow projection to be based on available meteorological past data for various design purposes (Jakob 2013). Seasonal fluctuations are commonly observed in quarterly or monthly hydrologic flow regime studies. As seasonality is a dominant feature in time series (Sultan and Janicot 2000), hydrologists have developed methodologies to routinely deseasonalized data for modelling and forecasting different annual conditions (Benkachcha et al. 2013). The common variation of inflow from one season to another mainly reflects the climatic variability which includes seasonality of rainfall and amount of evapotranspiration which is dependent on air temperature as well as precipitation in the basin (Ufoegbune et al. 2011). The understanding of these hydrological dynamics in a basin is crucial for sustainable water allocation planning and management. Different literature work reviews across the globe have found a nonlinear or linear relationship between station elevation and rainfall pattern, e.g., the Kruger National Park, South Africa and Mount Kenya, East Africa (Hawinkel et al. 2016; MacFadyen et al. 2018). Likewise, a linear pattern was found in a Spatio-temporal Island study in a European City (Arnds et al. 2017; Sohrobi et al. 2017) while a nonlinear relation exists in a central Asia Basin study (Dixon and Wilby 2019).

Rainfall heterogeneity obviously needs to be considered in a number of hydrological process studies in larger catchments area since it influences: infiltration dynamics, hydrograph regime, runoff volume, and peak flow (Bonaccorso et al. 2017; Fanelli et al. 2017; Gao et al. 2019; Tarasova et al. 2018). However, some hydrology studies still rely on small numbers of synoptic-scale rainfall measurements, and the problem of limited rainfall gauges is common in many watershed investigations, especially in developing countries (Birhanu et al. 2019; Liu et al. 2017; Moges et al. 2018). Therefore, prior to investigating the watershed functions and their contributions to the Mkomazi River flow, we examined the spatial attributes of rainfall in the area based on existing data. The past works conducted on the Basin includes Flügel et al.'s (2003) that had used a geographical information system (GIS) to regress the local rainfall to the elevation, while Oyeboode et al. (2014) has used genetic algorithm and ANN for the streamflow modelling at the upstream. Taylor et al. (2003) and Wotling et al. (2000) used rainfall intensity distribution and principal component analysis (PCA) to assess the complexity of the terrain in

addition to the elevation. In general, differences in rainfall patterns may have involved a combination of two statistical outcomes: a shift in the mean and a change in the scale of the distribution functions. The gamma distribution is a popular choice for fitting probability distributions to rainfall totals because its shape is similar to that of the histogram of rainfall data (Kim et al. 2019; Svensson et al. 2017).

Similarly, Najafi and Kermani (2017) observed that in recent years, many researchers have used various empirical rainfall-runoff models to study the impacts of climatic change on basin hydrology. However, a good understanding of the future rainfall distribution across these zones is of vital importance if any meaningful development is to take place in the water resource management and agricultural sector which has been of utmost priority in recent times (Arnds et al. 2017). However, in order to address the foregoing issues, there is a need for the study of this nature. It will help in developing long-term strategic plans for climate change adaptation and mitigation measures and implementing effective policies for sustainable water resources and management of irrigation projects and reservoir operations for the overall sustenance of human well-being in the region (Al-Kalbani et al. 2014). This chapter utilizes regression analysis to investigate the upstream–downstream linkages under seasonal climate variability. Hydrological trend characterization was based on available morphoclimatic past data. Sen’s slope (Pettitt’s) abrupt change detection and the Mann-Kendall parametric trend analysis were used in detecting long-term variability in precipitation while ANN was used for seasonal classifiers and potential future streamflow quantification. Quintile regression was used to establish the relationship between climate indicators (historical rainfall and streamflow) and past catchment conditions to forecast future hydrological dynamics in the MRB. The main novelty in this study is that such a time-series representation is useful for considering the influence of projected shifts in environmental factors on the hydrologic budget, and subsequent coping strategies can be provided.

The Mkomazi catchment is located in the U Basin within the semi-arid province of KwaZulu-Natal in South Africa as shown in Fig. 1. It is the third largest catchment in the province, draining an area of about 4400 km<sup>2</sup> with several large tributaries like Loteni, Nzinga, Mkomanzi, and Elands Rivers. The climatic condition of the study area varies with the seasonality of dry winters and wet summers (Flügel et al. 2003). Rainfall distribution is inconsistent along the catchment, ranging from nearly 1200 mm per annum at the headwaters to 1000 mm p.a. in the middle and 700 mm p.a. in the lower reaches of the catchment with highly intra- and interseasonal streamflows (Flügel and Märker 2003; Oyeboode et al. 2014; Taylor et al. 2003). Prior water allocations were entirely based on “who got there first,” which have become unstable and irrational with climate change. Thus, examining how climate-driven spatial and temporal changes to streamflows may reallocate water among the riparian users considering its seasonal variability is of immense importance. The Mkomazi River can be subdivided into five physiographic zones as shown in Fig. 2, namely:

- (I) The coastal lowlands up to 620 m (mean annual sea level – m a.s.l.)
- (II) The interior lowland area (“middle berg area”) from 620 to 1079 m (m.a.s.l.)

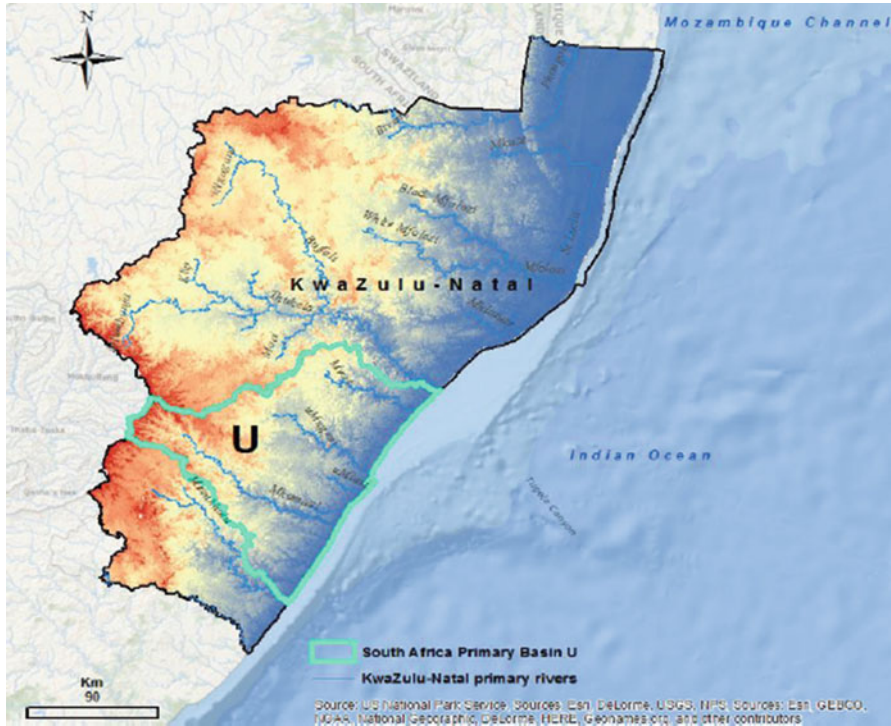


Fig. 1 The study area: Mkomazi River basin

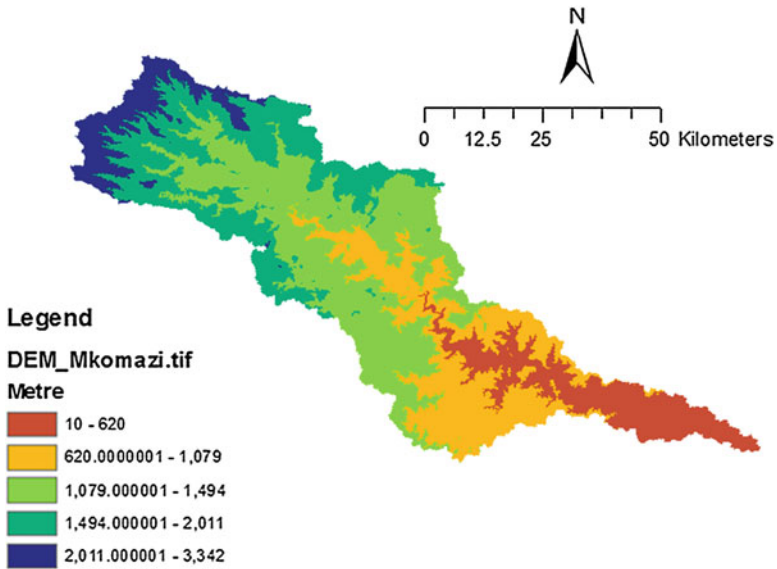


Fig. 2 Mkomazi Physiographic description with elevation zones

- (III) Lowland area up to 1494 m (m.a.s.l.)
- (IV) The mountain area up to 2011 m (m.a.s.l.)
- (V) The highlands, with elevations up to 3342 m (m.a.s.l.)

Like other catchments in Southern Africa, the study area is characterized by high varying seasonality of dry winters and wet summer (Schulze and Pike 2004a). Many authors have suggested longer record lengths, approximately 20-year oscillations interval, in measuring the seasonal hydrological fluctuation (Abhishek et al. 2012; Schulze 1995; Tyson 1986). This variability was adjudged to be as a result of the influence of the currents in the Atlantic and the Indian Ocean that surround the country. The cold Benguela Current in the Atlantic Ocean (South West) brings not only cold air but also influences the pressure system (Haigh et al. 2010; King et al. 2000), while the warmer currents of the Indian Ocean influence the milder warmer sea temperatures and the humid air on the Northeastern Coastline in the country. These seasons are opposite to the seasons in the northern hemisphere (King et al. 2000). There are no clear-cut seasonal calendar based on phenology for the country; however, conventional seasonal variability run through summer (Dec–Feb), autumn (March–May), winter (June–August), and spring usually between September and November, to which the average temperature ranges from 20 to 30; 10 to 15, 7 to 10, and 15 to 20 °C respectively (De Coning 2006; Schulze and Pike 2004a, b).

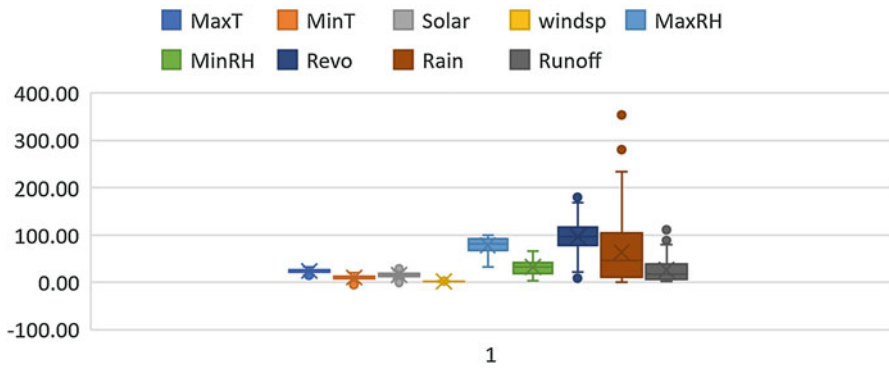
## Procedural Summary

The various stations source data from South Africa Weather Information System (SAWs), the Agricultural Research Council (ARC), and the Department of Water Affairs (DWA), South Africa, were processed and subjected to a rigorous scientific method to test their accuracy, reliability, homogeneity, consistency, and localization gaps. The detection of trends in a series of extreme values needs highly reliable data. Thus, only five stations met the above requirements and, as a result, corrected data sets were available for the hydrological years from 2008 to 2015 (for U10L 30530, U10J 30587, U10L 30813, U10 at Shelburn, and U10 at Giant Castle locations). Table 1 gives the statistical summary of the selected stations variables for (1985–2015) years.

Since the studied variables have different variances and units of measurements as shown in Table 1, the data set was standardized. This step was done by subtracting off the mean and dividing by the standard deviation (Ikudayisi and Adeyemo 2016). At the end of the standardization process, each variable in the dataset is converted into a new variable with zero mean and unit standard deviation. The original and standardized variables are displayed in Figs. 3 and 4, respectively. The standardized results are needed for minimization of bias and accumulation of predicted error from the observed data. These data were further subjected to various test/processing regarding homogeneity, consistency, and gaps closure before adaptation for model inputs. This helps to improve their predictive abilities and reduce uncertainty in data usage.

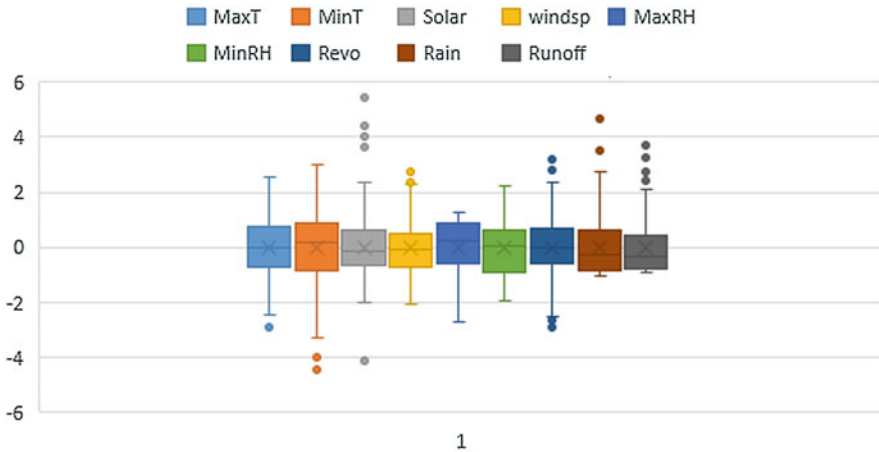
**Table 1** Statistical summary of the selected stations year (1985–2015) variables

Variables	Unit	Minimum	Maximum	Mean	Std. Dev
MaxT	°C	14.400	33.170	24.408	3.442
MinT	°C	-5.000	20.620	10.392	4.942
Solar	MJ/m <sup>2</sup>	0.030	36.450	15.691	3.884
windsp	[m/s]	0.650	3.367	1.794	0.561
MaxRH	%	33.000	99.930	78.425	16.712
MinRH	%	3.000	66.340	32.765	15.144
R Evap	mm	9.000	194.550	97.307	30.259
Rain	mm	0.000	353.200	64.394	61.918
Runoff	m <sup>3</sup> /s	2.018	123.639	26.217	26.216



**Fig. 3** Original data distribution of the climatic variables

Thus, the normalized data were used as input to the ANN classifier for seasonal forecasting and classification. Microsoft Statistical software XLSTAT by Addinsoft was used for Factor Analysis (FA) to explain the contribution of the unobserved common features in a target event from observed ones. FA as a choice of principal component analysis (PCA) was employed to reduce the variety of hydroclimatic data matrix to form a few selected derived component variables, which form a true representative of the original sets. The FA relates the trend, pattern, and fluctuations into wet or dry season in order to identify hydroclimatic variables responsible for streamflow characteristics as a basis for determining available water. This explains seasonal variation in water availability in the downstream environments. FA shows their level of influence and degree of different percentage contribution to the total streamflow volume (latent class). The regression relationships between the collected hydroclimatic data were developed as scatter plots and correlated to know their significance parameter sensitivity. Thereafter, the seasonal variability and trend detection were evaluated using Sen’s method abrupt change detection and Mann-Kendall trend analysis in forecasting the hydrologic flow regime.



**Fig. 4** Data standardization (normalization) of the climatic variables data

## Key Findings

### Seasonal Trend and Variability Changes among the Climatic Variables

A cursory run of the nonparametric and parametric approaches of Mann–Kendall and Sen’s methods across the months (Dec–Nov) for the study duration (1985–2015) shows the discernible trend and variability changes among the climatic variables. The value of Sen’s slope is given in Table 2 column 7. The closer it is to 0, the lesser the trend, while the sign of the slope indicates if the trend is increasing or decreasing. A Mann–Kendall test with a very high positive value of  $S$  (column 4) is an indication of an increasing trend while a very low negative value indicates a decreasing trend.

As shown in Table 2, decreasing trends are found generally among the variables across the months except for maximum temperature and solar radiation. This is understandable, as increased solar radiation brings about an increase in temperature. Increases in temperature and radiation forcing variables also alter the hydrological cycle. The resultant effect determines the amount of precipitation, its frequency, intensity duration, and the type of rainfall. In all, the hydro-meteorological variable shows a decreasing trend except for maximum temperature and evapotranspiration in the seasonal distribution pattern. The results show how changes in temperature and evapotranspiration could affect both the timing and total amounts of runoff, though the patterns of possible changes are both spatially and temporally complex. Future changes to allocation of water during seasonal water shortages is an important decision, which not only needs to be better coordinated within any given legal jurisdiction but needs to be better coordinated across any upstream and downstream uses and users.

**Table 2** The results of the Sen's slope and Mann–Kendall test. Seasonal Mann–Kendall Test/period = 12/serial independence /two-tailed test

Variables [1]	Unit [2]	Kendall's tau [3]	S [4]	Var(S) [5]	p-value (Two-tailed) [6]	Sen's slope [7]	Trend [8]
MaxT	°C	0.009	34.000	0.824	0.05	-0.026	Increasing
MinT	°C	-0.053	-191.000	0.200	0.05	-0.037	Decreasing
Solar	MJ/m <sup>2</sup>	-0.083	-296.000	0.046	0.05	-0.026	Decreasing
Windsp	[m/s]	-0.032	-115.000	0.442	0.05	-0.004	Decreasing
MaxRH	%	-0.205	-737.000	<0.0001	0.05	-0.546	Decreasing
MinRH	%	-0.168	-604.000	<0.0001	0.05	-0.475	Decreasing
R Evap	mm	0.067	242.000	0.104	0.05	0.318	Increasing
Rain	mm	-0.166	-596.000	<0.0001	0.05	-0.408	Decreasing
Runoff	m <sup>3</sup> /s	-0.039	-136.000	0.360	0.05	0	Decreasing

## Factor Analysis (FA) Findings

FA explores the dimensionality of a measurement instrument by finding the smallest number of interpretable factors needed to explain the correlations among the set of variables. This was particularly useful in the analysis of the meteorological parameters input for the ANN model. It places no structure on the linear relationships between the observed variables and the factors but only specifies the number of latent factors, determines the quality of the measurement instrument, identifies variables that are poor factor indicators, and are also poorly measured (Hu et al. 2014). The FA loading is shown in Table 3 to reduce the data into a smaller number of components which indicates what constructs underlies the data latent class. The bold squared cosine values depict the most significant variables that affect discharge flow.

The diagrammatical representation of the Factor Analysis as shown in Fig. 5 indicates each variable's level of significance on how they contribute to the total streamflow volume latent class. The table shows their proportionate percentage significance towards streamflow. All the meteorological data influence the streamflow except the wind speed presented in the statistical factor analysis biplot which stands alone thus depicting the least effect. This may suggest that air temperature is a more important climatic factor for water mass balance than precipitation.

## ANN Pattern Classifier and Flow Regime Variation

Insights into the ANN configuration for the four seasons' classification are given in Fig. 6. The ANN internal algorithm using the gradient descent method for the hidden layer was able to classify them into the four prominent seasons based on collected data which were sorted on monthly basis and labeled inclusively with 1 - Summer, 2- Autumn, 3-Winter, and 4- Spring, respectively. The developed ANN model in the present study consisted of eight input layers that represent the input vectors of the hydro-meteorological parameters considered and four output layers representing

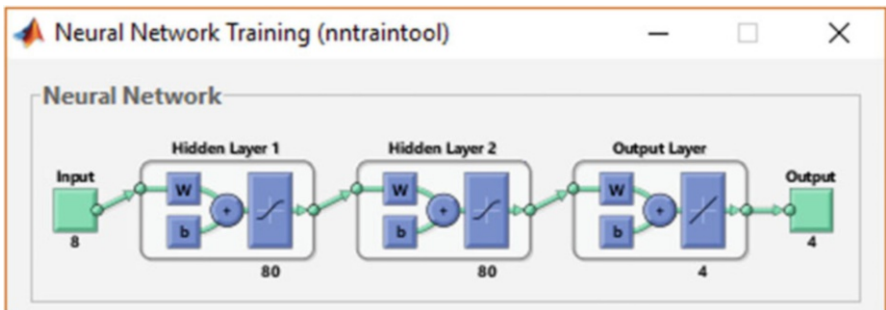
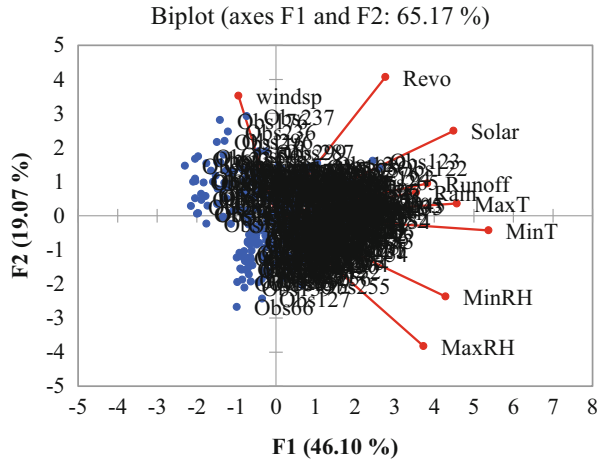
**Table 3** Factor loadings of the variables

Variables	Factor Loadings								
	F1	F2	F3	F4	F5	F6	F7	F8	F9
MaxT	<b>0.629</b>	0.004	0.235	0.038	0.008	0.046	0.022	0.006	0.013
MinT	<b>0.869</b>	0.006	0.000	0.036	0.016	0.011	0.026	0.016	0.020
Solar	<b>0.606</b>	0.186	0.009	0.003	0.037	0.033	0.122	0.004	0.000
Windsp	0.027	<b>0.372</b>	0.369	0.142	0.061	0.019	0.000	0.010	0.000
MaxRH	0.419	<b>0.441</b>	0.013	0.036	0.018	0.003	0.011	0.057	0.002
MinRH	<b>0.552</b>	0.169	0.150	0.045	0.009	0.035	0.004	0.026	0.010
Revo	0.230	<b>0.498</b>	0.028	0.041	0.049	0.147	0.005	0.002	0.000
Rain	<b>0.377</b>	0.014	0.236	0.204	0.122	0.011	0.034	0.001	0.001
Runoff	<b>0.440</b>	0.027	0.000	0.247	0.257	0.020	0.003	0.006	0.000

Values in bold correspond to each variable to the factor for which the squared cosine is the largest



**Fig. 5** The factor analysis based on their contributing factor of importance



**Fig. 6** MATLAB interphase for seasonal classification using hydro-meteorological data

the four seasons. The different monthly hydro-meteorological data of each of the six-catchment location serves as the raw data which was preprocessed to obtain the input vectors that was fed into the ANN. The MATLAB interface indicating the size of the input vector, a number of hidden layers, and neurons applied at the layers (which were experimentally determined) as well as the output layer is presented in Fig. 6, while Fig. 7 shows the confusion matrix obtained for the seasonal classification.

The confusion matrix indicating a 93.7% classification accuracy was achieved by the ANN classifier in cataloging the labeled data into the appropriate season. Given any unknown data set for the test, the developed model was able to distinguish it and classify it into the appropriate season. The corresponding number in the diagonal elements of the matrix indicates the number of instances that could be correctly classified for each of the seasons and how best the ANN classifier can recognize and distinguish data mined for each seasonal (summer, autumn, winter, and spring) classification respectively. The result of the optimal seasonal discharge forecast model is as presented in Fig. 8.

**Fig. 7** Seasonal classification by ANN model

**Confusion Matrix**

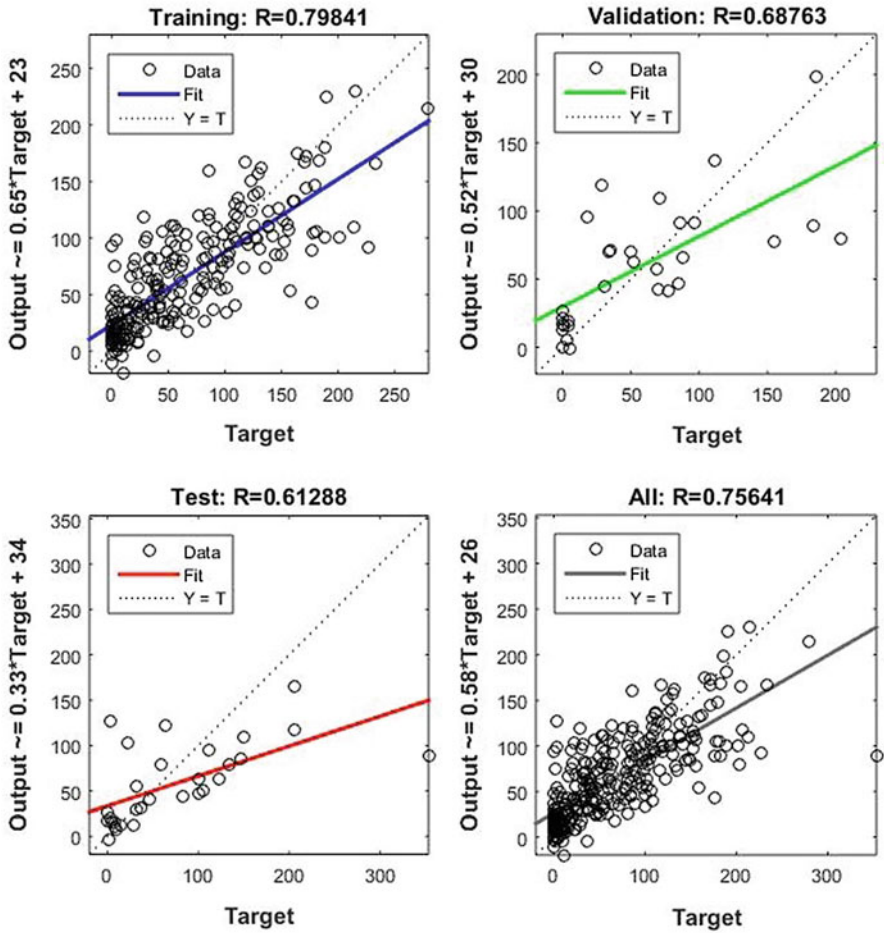
		<b>Target Class</b>				
		1	2	3	4	
<b>Output Class</b>	1	72 24.0%	0 0.0%	0 0.0%	3 1.0%	96.0% 4.0%
	2	7 2.3%	63 21.0%	3 1.0%	2 0.7%	84.0% 16.0%
	3	0 0.0%	0 0.0%	74 24.7%	1 0.3%	98.7% 1.3%
	4	2 0.7%	0 0.0%	1 0.3%	72 24.0%	96.0% 4.0%
			88.9% 11.1%	100% 0.0%	94.9% 5.1%	92.3% 7.7%

The ANN forecasted results provide the likelihood of high, near medium or low streamflow. The changes in the discharge regime were identified with the 5th, 10th, and 90th tercile streamflow magnitude curve as depicted in Fig. 9.

The streamflows in winter (wetter months) have increased slightly over the time period, whereas streamflows in summer (drier months) have decreased slightly. Figure 9 represents the estimated seasonal catchment yield of higher surface flow in winter with decreasing lower base flow across the seasons. Streamflow is observed to be at its lowest in the autumn period as the results further assert that climate change is real and have significance effects on the river flow regime (Archer et al. 2010; Schulze and Pike 2004a; Taylor et al. 2003; Viviroli et al. 2010). The coping strategy suggests sustainable use of any resource relies on the action of a number of regulatory mechanisms that prevent the user from reducing the ability of the system to provide services. “Polluter pays” principle was conceived as a way to proportionally allocate the effects of such alterations to those users that are responsible for them, thus producing a regulatory effect on the use of the resource. Also, the water allocation criteria include economic criteria with the aim of optimizing the economic value of the water resource.

**Model Performance and Evaluation Measures**

For improved accuracy, the root means square error (RMSE) and coefficient of correlation (CC) was used for performance evaluation measures during ANN

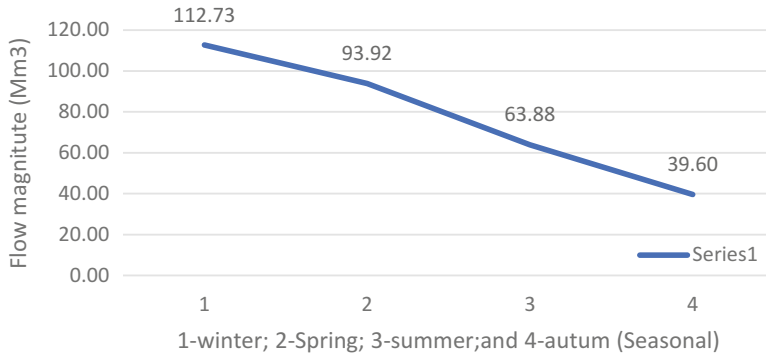


**Fig. 8** Training output values for the optimal seasonal discharge model

training, testing, and validation procedures (Paswan and Begum 2014). They are defined as shown in Eqs. (1) and (2), respectively.

$$RMSE = \sqrt{\frac{1}{n} \sum_{i=1}^n (Q_i - P_i)^2} \tag{1}$$

$$CC = \frac{\sum_{i=1}^n [(Q_i - \hat{Q}_i) \cdot (P_i - \hat{P}_i)]}{\sqrt{\sum_{i=1}^n (Q_i - \hat{Q}_i)^2 \cdot \sum_{i=1}^n (P_i - \hat{P}_i)^2}} \tag{2}$$

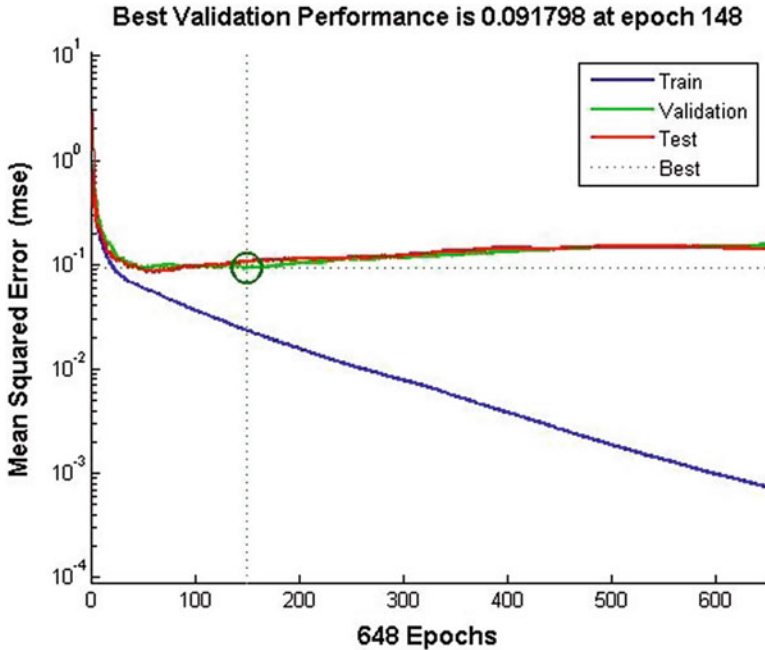


**Fig. 9** Seasonal variability flow dynamic across the river

where  $Q_i$  is the observed value at time  $i$ ,  $P_i$  is the simulated value at time  $i$  and  $\bar{P}$  is the mean for the observed values. Observed runoff is used for model calibration and validation. Correlations are useful because they can indicate a predictive relationship that can be exploited in practice. The performance measures of RMSE and CC values obtained are 29% and 61% respectively during the calibration period. During the verification period, the RMSE and CC values are slightly improved as 18% and 75% were achieved respectively. Figure 10 shows the result of the training test as well as the optimum prediction performance of the network architecture.

Using FA as part of PCA has helped in screening the data and identifying the level of importance based on their contributing factor. The observed MRB runoff at (Mkomazi drift UIH009) station was used to compare with the ANN-model-simulated output in Shrestha (2016) Calibration Helper v1.0 Microsoft Excel Worksheet. The model performance was evaluated using statistical parameters and the result is represented in Fig. 11. Comparing ANN simulated value and observed runoff variables show a satisfactory ANN forecasting model for the seasons run.

The resulting data from the four seasons were detrended and deseasonalized (Wang et al. 2011) before forecasting the time series using neural networks. The results show that the neural networks with the right configurations give almost the same accuracy with or without decomposition of the time series. The streamflows in wetter months have increased slightly over the time period from 1985 to 2015, whereas streamflows in drier months have decreased slightly. These trends are also evident for the minimum and maximum temperature and relative humidity multiday events. The relationship between runoff and Mkomazi rainfall has been high and stable over the recording period. Other data analysis not presented shows a decreasing trend of precipitations. The summer rainfall variations are related more closely to maximum than minimum temperatures, with higher temperatures associated with lower rainfall. Lower rainfall in winter tends to be linked with higher maximum and lower minimum temperatures. These relationships were relatively stable over time. For this reason, there is a need to consider a range of possible future climate

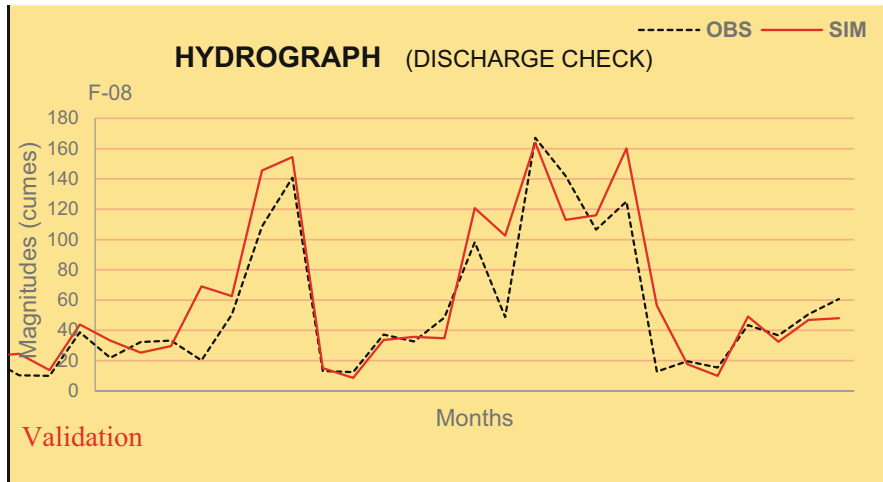


**Fig. 10** Performance evaluation measures

conditions in a region of increasing population, coupled with increasing demand for water resources for domestic, agricultural, and industrial activities and how these will affect water availability.

**Limitations of the Study**

Like all modeling studies, this research has assumptions and uncertainties which limit the findings. Many of the previous studies indicate that stationary climatic and streamflow data were used while we applied the historical probability that each water year type is based on the 2008 water year. This method assumes stationary climatic water year types. Future water year type frequencies varied somewhat with climate change (nonstationarity in data), although those changes are statistically insignificant. Also, decadal to multidecadal variability which includes the probability of extreme floods and droughts (Herrfahrdt-Pähle 2010) were not considered. Our findings likely underestimate water allocation impacts from extreme floods and droughts anticipated with climate change. In addition, for environmental flow allocations and streamflow, there is still substantial room for model misspecification through overfitting, thus the selection of optimal internal neural algorithms choice again raises the issue of robust neural network modeling.



Output statistics	Calibration	Validation
NSE	0.62	0.77
NSE <sub>rel</sub>	0.47	-0.32
R <sup>2</sup>	0.77	0.83
wR <sup>2</sup>	0.62	0.69
RSR	0.53	0.48
PBIAS	3.10%	13.90%

Fig. 11 Comparison of ANN simulated value and observed runoff

### Seasonal Coping and Adaption Strategies to Climate Variability

Practical field investigation of views of stakeholders and their involvement should be simulated with model computer software in evolving solutions to water availability. Government political will and strategical alignment of various duplicating agencies in providing data for Sub-seasonal to Seasonal (S2S) Prediction should be harmonized toward a unified goal. Historically disadvantaged communities must be strongly supported and be encouraged to apply for water use licenses and the region must be in readiness to fast-track the processing of these water use license applications. Other available strategies to cope with climate variability include integrated water resources management by improving public water supply, regulating final users by facilitating the emergence of mediating agencies, the use of energy pricing and supply to manage agricultural water use overdraft, and better sensitization campaigns on rain water capture and recharge. The formalization of the water sector through the transfer of water rights and the more efficient use of water resources are among evolving strategies to achieve a sustainable water supply for the Mkomazi

River Basin. Turning all these adaptation strategies into opportunity requires a need for both water technology innovation and water behavioral change to manage the scarcity of water resources in a sustainable manner. This chapter offers intuitive suggestions on how human being policies and cautious approaches can be used to manage and sustain the already depleted environment. Such intuitive agenda should be catalyzed through the institutionalization of proactive and capacity developmental platforms where climate change experts transfer knowledge, skills and expertise to upcoming researchers.

---

## Conclusion

Understanding of climate change is continually improving, but the future climate remains uncertain (Yuan et al. 2016). For this purpose, a regression nonparametric approach consisting of the Mann–Kendall test and Sen’s method and a parametric approach (ANN) based on factor analysis of extremes statistical theory have been applied. Owing to the seasonal character of the upstream–downstream variables linkages, the result concludes that all the variables considered the temperature as the most important factor in the estimation of streamflow. The results suggest a significant impact of input vector length, a few hidden nodes neurons, and the choice of activation function as ANN potentiality in characterizing the individual season and project maximum likelihood trend for the surface water patterns. Thus, careful assessment of the available water resources and reasonable needs of the basin/region in foreseeable future for various purposes must be based on reliable information concerning the meteorological variable trend which in turn impacts the peak flow to be expected after a rainstorm of a given probability of occurrence. The methods applied further confirms our assertion that these patterns are indeed unique across each month in the season. The water resources manager and agricultural water management sector would find optimal use in the developed ANN classifier model that links hydrologic variability on different temporal trend scales based on available past data and rainfall anomaly.

**Acknowledgments** The financial support from the National Research Foundation (NRF) of South Africa in research and innovation advancement – UID Grants: 103232 – is well appreciated.

---

## References

- Abhishek K, Singh M, Ghosh S, Anand A (2012) Weather forecasting model using artificial neural network. *Procedia Technol* 4:311–318
- Al-Kalbani MS, Price MF, Abahussain A, Ahmed M, O’Higgins T (2014) Vulnerability assessment of environmental and climate change impacts on water resources in Al Jabal Al Akhdar, Sultanate of Oman. *Water* 6(10):3118–3135
- Archer E, Engelbrecht F, Landman W, Le Roux A, Van Huyssteen E, Fatti C, . . . Colvin C (2010) South African risk and vulnerability atlas. Department of Science and Technology, South Africa

- Arnds D, Böhner J, Bechtel B (2017) Spatio-temporal variance and meteorological drivers of the urban heat island in a European city. *Theor Appl Climatol* 128(1–2):43–61
- Bayazit M (2015) Nonstationarity of hydrological records and recent trends in trend analysis: a state-of-the-art review. *Environ Process* 2(3):527–542
- Benkachcha S, Benhra J, El Hassani H (2013) Causal method and time series forecasting model based on artificial neural network. *Int J Comput Appl* 75(7):37
- Birhanu BZ, Traoré K, Gumma MK, Badolo F, Tabo R, Whitbread AM (2019) A watershed approach to managing rainfed agriculture in the semiarid region of southern Mali: integrated research on water and land use. *Environ Dev Sustain* 21(5):2459–2485
- Bonaccorso B, Brigandi G, Aronica GT (2017) Combining regional rainfall frequency analysis and rainfall-runoff modelling to derive frequency distributions of peak flows in ungauged basins: a proposal for Sicily region (Italy). *Adv Geosci* 44:15
- De Coning C (2006) Overview of the water policy process in South Africa. *Water Policy* 8(6): 505–528
- Dixon SG, Wilby RL (2019) A seasonal forecasting procedure for reservoir inflows in Central Asia. *River Res Appl* 35(8):1141–1154
- Egüen M, Aguilar C, Solari S, Losada M (2016) Non-stationary rainfall and natural flows modeling at the watershed scale. *J Hydrol* 538:767–782
- Fanelli R, Prestegard K, Palmer M (2017) Evaluation of infiltration-based stormwater management to restore hydrological processes in urban headwater streams. *Hydrol Process* 31(19): 3306–3319
- Flügel W-A, Märker M (2003) The response units concept and its application for the assessment of hydrologically related erosion processes in semiarid catchments of Southern Africa. In: *Spatial methods for solution of environmental and hydrologic problems – science, policy, and standardization*. ASTM International, West Conshohocken
- Flügel WA, Märker M, Moretti S, Rodolfi G, Sidrochuk A (2003) Integrating geographical information systems, remote sensing, ground truthing and modelling approaches for regional erosion classification of semi-arid catchments in South Africa. *Hydrol Process* 17(5):929–942
- Gao H, Birkel C, Hrachowitz M, Tetzlaff D, Soulsby C, Savenije HH (2019) A simple topography-driven and calibration-free runoff generation module. *Hydrol Earth Syst Sci* 23:787
- Gober P (2018) Why is uncertainty a game changer for water policy and practice? In: *Building resilience for uncertain water futures*. Springer, Cham, pp 37–60
- Graham LP, Andersson L, Horan M, Kunz R, Lumsden T, Schulze R, ... Yang W (2011) Using multiple climate projections for assessing hydrological response to climate change in the Thukela River Basin, South Africa. *Phys Chem Earth Parts A/B/C* 36(14):727–735
- Haigh E, Fox H, Davies-Coleman H (2010) Framework for local government to implement integrated water resource management linked to water service delivery. *Water SA* 36(4):475–486
- Hawinkel P, Thiery W, Lhermitte S, Swinnen E, Verbist B, Van Orshoven J, Muys B (2016) Vegetation response to precipitation variability in East Africa controlled by biogeographical factors. *J Geophys Res Biogeophys* 121(9):2422–2444
- Herrfahrdt-Pähle E (2010) South African water governance between administrative and hydrological boundaries. *Clim Dev* 2(2):111–127
- Hu Q, Su P, Yu D, Liu J (2014) Pattern-based wind speed prediction based on generalized principal component analysis. *IEEE Trans Sustain Energy* 5(3):866–874
- Ikudayisi A, Adeyemo J (2016) Effects of different meteorological variables on reference evapotranspiration modeling: application of principal component analysis. *World Acad Sci Eng Technol Int J Environ Chem Ecol Geol Geophys Eng* 10(6):641–645
- Jakob D (2013) Nonstationarity in extremes and engineering design. In: *Extremes in a changing climate*. Springer, Dordrecht, pp 363–417
- Katz RW (2013) Statistical methods for nonstationary extremes. In: *Extremes in a changing climate*. Springer, Dordrecht, pp 15–37
- Katz RW, Parlange MB, Naveau P (2002) Statistics of extremes in hydrology. *Adv Water Resour* 25 (8–12):1287–1304



- Kim Y, Kim H, Lee G, Min K-H (2019) A modified hybrid gamma and generalized Pareto distribution for precipitation data. *Asia-Pac J Atmos Sci* 55(4):609–616
- King JM, Tharme RE, De Villiers M (2000) Environmental flow assessments for rivers: manual for the building block methodology. Water Research Commission, Pretoria
- Kundzewicz Z, Mata L, Arnell NW, Döll P, Jimenez B, Miller K, . . . Shiklomanov I (2008) The implications of projected climate change for freshwater resources and their management. *Hydrol Sci J* 53:3
- Liu X, Liu FM, Wang XX, Li XD, Fan YY, Cai SX, Ao TQ (2017) Combining rainfall data from rain gauges and TRMM in hydrological modelling of Laotian data-sparse basins. *Appl Water Sci* 7(3):1487–1496
- MacFadyen S, Zambatis N, Van Teeffelen AJ, Hui C (2018) Long-term rainfall regression surfaces for the Kruger National Park, South Africa: a spatio-temporal review of patterns from 1981 to 2015. *Int J Climatol* 38(5):2506–2519
- Makkeasorn A, Chang N-B, Zhou X (2008) Short-term streamflow forecasting with global climate change implications—a comparative study between genetic programming and neural network models. *J Hydrol* 352(3–4):336–354
- Moges MM, Abay D, Engidayehu H (2018) Investigating reservoir sedimentation and its implications to watershed sediment yield: the case of two small dams in data-scarce upper Blue Nile Basin, Ethiopia. *Lakes Reserv Res Manag* 23(3):217–229
- Najafi R, Kermani MRH (2017) Uncertainty modeling of statistical downscaling to assess climate change impacts on temperature and precipitation. *Water Resour Manag* 31(6):1843–1858
- Null SE, Prudencio L (2016) Climate change effects on water allocations with season dependent water rights. *Sci Total Environ* 571:943–954
- Null SE, Viers JH, Mount JF (2010) Hydrologic response and watershed sensitivity to climate warming in California’s Sierra Nevada. *PLoS One* 5(4):e9932
- Oyebode O, Adeyemo J, Otieno F (2014) Monthly stream flow prediction with limited hydro-climatic variables in the Upper Mkomazi River, South Africa using genetic programming. *Fresenius Environ Bull* 23(3):708–719
- Paswan RP, Begum SA (2014) ANN for prediction of area and production of maize crop for Upper Brahmaputra Valley Zone of Assam. Paper presented at the advance computing conference (IACC), 2014 IEEE international
- Poff NL (2018) Beyond the natural flow regime? Broadening the hydro-ecological foundation to meet environmental flows challenges in a non-stationary world. *Freshw Biol* 63(8):1011–1021
- Schulze RE (1995) Hydrology and agrohydrology: a text to accompany the ACRU 3.00 agrohydrological modelling system. Water Research Commission, Pretoria
- Schulze R, Pike A (2004a) Development and evaluation of an installed hydrological modelling system. Water Research Commission, Pretoria
- Schulze R, Pike A (2004b) Development and evaluation of an installed hydrological modelling system. Water Research Commission report (1155/1), 04. Water Research Commission, Gezina
- Shrestha PK (Producer) (2016, 14, May 2017) SWAT Calibration Helper v1.0 Microsoft Excel Worksheet. Retrieved from <https://www.researchgate.net/publication/>
- Sohrabi MM, Benjankar R, Tonina D, Wenger SJ, Isaak DJ (2017) Estimation of daily stream water temperatures with a Bayesian regression approach. *Hydrol Process* 31(9):1719–1733
- Sultan B, Janicot S (2000) Abrupt shift of the ITCZ over West Africa and intra-seasonal variability. *Geophys Res Lett* 27(20):3353–3356
- Svensson C, Hannaford J, Prosdociimi I (2017) Statistical distributions for monthly aggregations of precipitation and streamflow in drought indicator applications. *Water Resour Res* 53(2): 999–1018
- Tarasova L, Basso S, Zink M, Merz R (2018) Exploring controls on rainfall-runoff events: 1. Time series-based event separation and temporal dynamics of event runoff response in Germany. *Water Resour Res* 54(10):7711–7732
- Taylor V, Schulze R, Jewitt G (2003) Application of the indicators of hydrological alteration method to the Mkomazi River, KwaZulu-Natal, South Africa. *Afr J Aquat Sci* 28(1):1–11

- Taylor RG, Scanlon B, Döll P, Rodell M, Van Beek R, Wada Y, . . . Edmunds M (2013) Ground water and climate change. *Nat Clim Chang* 3(4):322–329
- Tyson PD (1986) *Climatic change and variability in southern Africa*. Oxford University Press, Oxford
- Ufoegbune GC, Yusuf HO, Eruola KO, Awomeso JA (2011) Estimation of water balance of Oyan Lake in the North West Region of Abeokuta, Nigeria. *Br J Environ Climate Change* 1(1):13–27. Retrieved from SCIENCEDOMAIN international [www.sciencedomain.org](http://www.sciencedomain.org)
- Viviroli D, Archer D, Buytaert W, Fowler H, Greenwood G, Hamlet A, . . . López-Moreno J (2010) Climate change and mountain water resources: overview and recommendations for research, management and politics. *Hydrol Earth Syst Sci Discuss* 7(3):2829
- Wang S, Yu L, Tang L, Wang S (2011) A novel seasonal decomposition based least squares support vector regression ensemble learning approach for hydropower consumption forecasting in China. *Energy* 36(11):6542–6554
- Wotling G, Bouvier C, Danloux J, Fritsch J-M (2000) Regionalization of extreme precipitation distribution using the principal components of the topographical environment. *J Hydrol* 233 (1–4):86–101
- Yuan F, Berndtsson R, Uvo CB, Zhang L, Jiang P (2016) Summer precipitation prediction in the source region of the Yellow River using climate indices. *Hydrol Res* 47(4):847–856

**Open Access** This chapter is licensed under the terms of the Creative Commons Attribution 4.0 International License (<http://creativecommons.org/licenses/by/4.0/>), which permits use, sharing, adaptation, distribution and reproduction in any medium or format, as long as you give appropriate credit to the original author(s) and the source, provide a link to the Creative Commons license and indicate if changes were made.

The images or other third party material in this chapter are included in the chapter's Creative Commons license, unless indicated otherwise in a credit line to the material. If material is not included in the chapter's Creative Commons license and your intended use is not permitted by statutory regulation or exceeds the permitted use, you will need to obtain permission directly from the copyright holder.





# Adaptation to Climate Change: Opportunities and Challenges from Zambia

# 99

Jonty Rawlins and Felix Kanungwe Kalaba

## Contents

Introduction .....	206
Climate Change in Southern Africa and Zambia .....	208
Methodology .....	2028
Climate Change Risk Pathways in Zambia .....	2029
Infrastructure Risk .....	2030
Socioeconomic Risk .....	2030
Human Health Risk .....	2031
Agricultural Risk .....	2031
Environmental Change Risk .....	2032
Cumulative Risks and Positive Feedback Loops .....	2033
Barriers to Adaptation and Resilience Building .....	2033
Poor Livelihood and Economic Diversification .....	2033
High Rates of Land Degradation .....	2034
Low Levels of Technical and Technological Capacities .....	2034
Inadequate Infrastructure .....	2035
Entrenched Culturally and/or Policy-Driven Practices .....	2035
Weak Policy Implementation .....	2035
Persistent Inequalities .....	2036
Cumulative Barriers and Positive Feedback Loops .....	2036
Toward Improved Climate Change Adaptation .....	2037
Maladaptation Potential .....	2037
Is Livelihood and Economic Diversification the Answer? .....	2038

This chapter was previously published non-open access with exclusive rights reserved by the Publisher. It has been changed retrospectively to open access under a CC BY 4.0 license and the copyright holder is “The Author(s)”. For further details, please see the license information at the end of the chapter.

J. Rawlins (✉)

Natural Resources, OneWorld Sustainable Investments, Cape Town, South Africa

e-mail: [jrawlins@outlook.com](mailto:jrawlins@outlook.com)

F. K. Kalaba

School of Natural Resources, Copperbelt University, Kitwe, Zambia

© The Author(s) 2021

W. Leal Filho et al. (eds.), *African Handbook of Climate Change Adaptation*,

[https://doi.org/10.1007/978-3-030-45106-6\\_167](https://doi.org/10.1007/978-3-030-45106-6_167)

2025

Conclusions and Recommendations .....	2039
References .....	2041

---

## Abstract

Context appropriate adaptation interventions and strategies that respond directly to localized climate change stressors, hazards, and vulnerabilities are critical for the sustainable development of countries like Zambia. This chapter examines both localized and systemic climate change risk pathways and barriers to adaptation action in Zambia.

A three-staged methodology was applied, combining content analysis, focus group discussions, and expert interviews. Livelihood diversification was identified as the central adaptation option across Zambia, despite little empirical research detailing possible risks of diversification. The dominant adaptation discourse is focused specifically on diversifying within agriculture-based livelihoods. However, as all agricultural activities are impacted by climate change, diversification also needs to be explored in value-added or alternative sectors. With this, a weak policy framework and enabling environment are exacerbating cycles of poverty that underpin climate change vulnerability in Zambia. Moreover, maladaptation risks of existing diversification interventions are high as generic approaches often do not provide suitable options to complex and localized risk profiles.

To implement a sustainable transition toward climate resilient and compatible development in Zambia, the authors recommend that a systematic livelihood diversification strategy should be rolled out and future research programs designed to support this. Specifically, this necessitates a system-wide analysis of pre-identified livelihood diversification pathways that can be adapted to different scenarios given the current and future climate uncertainties at local scales. The approach should focus on harnessing the positive feedback loops for systematic change to build resilience, while minimizing the dominant risk pathways and eliminating persistent barriers that enable positive feedback loops driving vulnerability to climate change. Thorough stakeholder engagement and incremental development of diversification options, incentives, penalties, and other governance and/or policy mechanisms will be needed to support these processes.

---

## Keywords

Climate change · Adaptation · Sustainable development · Diversification · Zambia

---

## Introduction

There is increasing evidence of the existing and potential impacts of climate change on ecosystems and society (Fischer 2019; Grüneis et al. 2018). These impacts are projected to increase in southern Africa due to projected increases in exposure and existing high levels of sensitivity and low levels of adaptive

capacity (IPCC 2018). Climate change poses complex challenges to development planning and management at various scales (national, regional, and local) (Whitney and Ban 2019) through a multitude of risk pathways. Globally, enabling effective and efficient adaptation interventions has become a major policy goal over the last decade (Fischer 2019). Recent evidence suggests that adaptation strategies and policies are often developed using a top-down approach (Grüneis et al. 2018). However, there are increasingly urgent calls for locally appropriate adaptation strategies that respond to local scale climate hazards, stressors and vulnerabilities and take cognizance of localized socioeconomic and environmental conditions. Conventional public policy and sustainable development strategies do not effectively incorporate climate change impacts and projections (Whitney and Ban 2019) at a localized scale, often resulting in unintended negative consequences. Designing and implementing effective adaptation actions requires the active participation of local practitioners in order to make decisions on adaptation choices and activities that are locally relevant, credible, and contextually appropriate.

A variety of adaptation measures have been proposed across Africa. However, there is little empirical evidence of how adaptation decisions are contextually developed and to what degree local institutions participate and/or drive such processes. Local institutions understand local contexts and the various climate hazards within their regions and therefore need to be key decision-makers in the development of adaptation strategies and policies (Fischer 2019; Kupika et al. 2019). This is evidenced by extensive scholarship exploring the pervasiveness of maladaptation (e.g., Juhola et al. 2016; Magnan et al. 2016) and issues of scale and applicability of generic adaptation investments under deep uncertainty (Haasnoot et al. 2019; Hallegatte et al. 2012). This is of particular importance in developing adaptation responses to pursue sustainable development outcomes, taking into consideration ecological and social coping and adaptation capacities at multiple spatial scales.

Effective adaptation minimizes negative impacts and maximizes the potential benefits of climate change (Whitney and Ban 2019) given the resource constraints of a particular socio-ecological system. Thus, effective local strategies will, to a large extent, depend on the understanding and perceptions of local actors about opportunities to inform adaptation strategies (Whitney and Ban 2019). Thus, it is clear that pragmatic adaptation actions demand participation of all key local actors and institutions.

This chapter examines the risks from climate change that are currently being experienced and further explores current and future adaptation strategies and barriers to adaptation. Complex and cumulative climate change risk pathways and key barriers to adaptation and resilience building are explored through analyzing perceptions of local actors and institutions within the broader policy and environmental context of Zambia. The overarching objective of this research is to assess and recommend context appropriate and systemic adaptation interventions and strategies that respond directly to both national and localized climate change risks and vulnerabilities.

## Climate Change in Southern Africa and Zambia

Southern Africa is one of the global climate change hotspots (IPCC 2018). Anthropogenically driven temperature rise is at approximately twice the average global rate of temperature increase (Weber et al. 2018). This is combined with the observed increased frequency and intensity of extreme events such as droughts, heavy rainfall events, heat waves, and floods over the past few decades (Paeth et al. 2010; Taylor et al. 2017). Climate projections for the region also indicate rises in temperatures, an increase in hot days, heat waves, and heat stress as well as continued increases in the frequency and magnitude of extreme events such as droughts and floods (Engelbrecht et al. 2015; Dosio 2017; Maure et al. 2018).

The severity of these impacts will be magnified by low levels of adaptive capacity, stemming from a plethora of socioeconomic and environmental challenges facing the Southern African region. These factors include rapid population growth, natural resource-related poverty and inequality, regional migration, significant infrastructure deficits, low levels of access to clean water and sanitation, and inefficient food, and energy systems among others (Nhamo et al. 2018; Rawlins et al. 2018).

Zambia is no exception to these trends, with severe climate change impacts projected for the economy, local livelihoods, and the broader environment (Kaluba 2014; World Bank 2019). The country is particularly vulnerable to floods and droughts, which in the past 30 years have cost the country an estimated 13.8bn USD, equivalent to around 0.4% of GDP (Kaluba 2014). Zambia has also seen decreased rainfall by an average rate of 1.9 mm/month (2.3%) per decade since 1960, and the rainfall season has become shorter and more difficult to predict – with fewer, but more intense rainfall events (AfDB 2019; ZINDC 2015). Mean annual runoff is estimated to decrease by ~13%, under future climate change scenarios (Hamududu and Ngoma 2018). This, combined with increasing climate variability, is reducing water availability across the country. Moreover, vulnerability to climate extremes such as droughts and floods is also increasing, posing a significant threat to water security in the country.

Future scenarios for Zambia over the period 2070–2099 indicate that temperatures will increase by 2 °C and rainfall could decrease by 8–10% (Bwalya 2010) with an indication of heavy rainfall events becoming more frequent in the northern highlands (AfDB 2019). As stated above, the frequency of extreme events (droughts, seasonal floods and flash floods, extreme temperatures, and dry spells), along with their intensity and magnitude, has also increased, and is already having notable knock-on effects for local livelihoods.

---

## Methodology

This chapter adopted a three-staged methodological approach, combining technical content analysis, focus group discussions, and semi-structured expert interviews. In the first stage, we conducted an extensive content analysis of key Zambian national policies that address adaptation to climate change and broader sustainable

development in one way or another. This included the 2017 National Climate Change Policy, national sectoral policies (water, agriculture, and forestry), and national development plans (Seventh National Development plan and the Vision 2030). Analyzing these policies provided insights on policy direction at the national level and to what degree adaptation to climate change is addressed both implicitly and explicitly as well as the complex interrelations and interdependencies between adaptation and sustainable development objectives.

The second stage involved provincial workshops and a national stakeholder workshop (Lusaka, Zambia, August 2018). Provincial workshops were arranged by district sectoral leads. A total of three provincial level workshops were conducted in Western, Luapula and Northern provinces. These were useful in providing insights into key climate risks being experienced in the various districts of the provinces, and the possible adaptation interventions, which were prioritized by local participants. Participants were drawn from a variety of government departments, NGOs, private sector, and civil society organizations (CSOs). Provincial workshops had an average of 45 participants. We further conducted key informant interviews with provincial heads to understand how localized climate risks in each province related to national, provincial, and local policies and strategies for adaptation and sustainable development. These semi-structured interviews provided the necessary depth in understanding the drivers of and barriers to effective adaptation as well as how these different risks and barriers can interact and accumulate throughout socio-ecological systems. Lastly, we conducted a national workshop, which was attended by 60 experts drawn from across government departments (forestry, agriculture, environment, national development planning, and water), NGOs, and academics.

Finally, semi-structured expert interviews were carried out with experienced academics and practitioners working on a variety of climate change, natural resource, and sustainable development challenges in Zambia and Southern Africa at large. This multistaged approach has been widely used in related studies (e.g., Antwi-Agyei et al. 2018; England et al. 2018). The combination of content analysis, focus group discussions, workshops, and in-depth interviews was shown to be useful in identifying risks, barriers, and possible investments to help adapt to climate change. Specifically, the iterative development of the key findings of the analysis assisted the verification and validation of proposed systemic adaptation responses that will address both national and localized climate change risks in an integrated manner.

---

## Climate Change Risk Pathways in Zambia

Zambia faces a multitude of climate change risks related to not only the direct effects of climate change but also to infrastructure, social and economic conditions, human health, agriculture, and the natural environment, among others. These risks manifest through a multitude of risk pathways with a variety of impacts over different time horizons that disproportionately impact the most vulnerable

populations. Additionally, cumulative impacts of these risks regularly lead to positive feedback loops that serve to magnify localized climate change risks.

## Infrastructure Risk

Heavy flooding frequently cuts road access to districts and their administrative centers. Some of the largest contributors to climate sensitivity and vulnerability in Zambia are low road density, the poor quality of many roads, the inability to traverse them for extended periods in the wet season, and the lack of maintenance and “climate proofing” of existing roads (Petrie et al. 2018).

An example of the impact of damage to infrastructure given by workshop participants was that, in remote districts, teachers may not be paid their monthly salaries for months at a time when floods cut road access. Left without an income, they must find the means to obtain food, which they may do by growing food crops themselves. This takes time that they would otherwise use for their teaching load (planning and administrative tasks), which affects the quality of education they deliver. Alternatively, teachers who find this situation difficult may not last more than 2 years in this employment and then leave, resulting in annual staff turnover as high as 30% (EPDC 2012).

Hydropower accounts for the vast majority of Zambia’s energy supplies, with a number of systems currently in operation and a significant amount of planned future generation (e.g., the planned Batoka Gorge Hydropower Plant). The demand for energy is driving continued hydropower development in the region, despite the significant potential decline in hydropower output projected under a drying climate in the Zambezi Basin (Spalding-Fecher et al. 2017). The highly centralized nature and sheer size of the financial investments required to support hydropower infrastructure presents a significant fiscal risk to Zambia given these potential impacts of climate change.

Other examples of the direct and indirect impacts arising from vulnerable road infrastructure are reduced economic activity (trade cannot take place, as markets are inaccessible); and a seasonal lack of access to health and educational facilities. Finally, to compound these factors, authorities are unable to deliver aid when it is needed in times of disaster.

## Socioeconomic Risk

Flooding destroys homes as well as crops and livestock and other household assets. This has an impact on public, household, and individual health and severely affects the access of households to social services. The poor road infrastructure restricts commercial enterprise, depressing local and regional economies and increasing the socioeconomic risks of the region.

A high population growth rate is a key underlying driver of vulnerability, with the rate often exceeding the ability of the economy to absorb job seekers. This highlights the potential future risks to local economies and threatens the ability of social



services such as education and health facilities to cope with the situation. High levels of education give people more options in terms of diversified livelihoods and income generating activities, while poor access to schooling and poor education or low levels of education hinders adaptation. Without education, people are forced to fall back more strongly on traditional income generation practices. Moreover, risks from the impacts of climate change are exacerbated by the lack of income diversity and high levels of poverty in general.

Gender equality is low in rural areas of Zambia and gender-based violence is common (Samuels et al. 2015). For example, early marriages lead to increased vulnerability of the affected girls. Education levels are low especially for girls who drop out of school to get married. With limited skills, women are restricted in terms of both the value they can add to available natural resources, and the ability to utilize various economic opportunities that would increase the efficiency and productivity of households to improve their adaptive capacities.

## Human Health Risk

An unhealthy population (or one with a high burden of disease) has a lower resilience to climate change impacts that challenge human health (Smith et al. 2014). HIV/Aids, malaria, and tuberculosis are the most prevalent and therefore serious diseases in Zambia. In addition, the incidence of these diseases reduces the resilience of those individuals and communities affected by other health challenges (i.e., comorbidities).

Poor health infrastructure – inadequate resources, including too few health facilities and staff – is a significant source of vulnerability. This is exacerbated by the remoteness of many districts, and poor roads, meaning that some areas are periodically isolated from health facilities during the wet season, with its concomitant impacts of flooding. It is unclear at this stage how emerging global health risks such as the Corona Virus 2019 (COVID-19) will be influenced by climate change risks; however, it is clear that the potential knock-on effects of a national or global pandemic will further limit the available health infrastructure capacity.

Social issues that result from climate-induced stresses include impacts on mental health. Climate change can affect people directly through trauma, which is evident in climate hazards such as floods. It also affects mental health indirectly, through impacts on physical health and broader community well-being (Berry et al. 2010).

Heat waves and persistent high temperatures will not only alter disease vector habitat distribution (such as malaria and tsetse fly, see Caminade et al. (2014) and Terblanche et al. (2008)), but also pose direct threats to human health in the form of heat stroke, exhaustion, and death.

## Agricultural Risk

Flooding is hazardous to crops across Zambia, though this risk profile varies from region to region. For example, in the higher, steeper areas of districts in Muchinga

Province, flooding is less of a risk because smaller areas of crops are exposed to the hazard. However, crops along the major rivers can be exposed to prolonged periods of heavy flooding, for example, those in Western Province or parts of Luapula and Northern provinces. With a substantial portion of their food resources for a season destroyed, people must seek alternative forms of income, including relocating for at least part of the agricultural year to other regions in order to generate an income, often by selling labor, charcoal manufacture, or fishing.

The impact of drought on crops and livelihoods varies between the provinces and their districts. In general, mean annual rainfalls are lower in the western and southern regions of Zambia, and droughts are more intense and longer than elsewhere. Droughts in this region have very significant impacts on crop yield. In the northern provinces, where mean annual rainfalls are significantly higher, drought is not a significant risk.

Temperature increases above certain thresholds substantially reduce the grain yield of maize, especially in soils which have a poor water holding capacity (see, e.g., Hatfield and Prueger 2015). This effect is more likely in the western and southern provinces than in the northern provinces, which are at higher altitudes, with higher rainfall and longer growing seasons.

Storm damage to crops – a result of high windspeed during intense events, or hail, is known as a relatively localized event. While devastating for the affected households, these usually do not occur at district or provincial level. Climate change has shown to have negative effects on livestock leading to reduction in available fodder for animals due to droughts. Floods also affect livestock by reducing the grazing land available, further increasing pressure. Disease incidence for livestock also increased with corresponding increase in animal mortality.

## Environmental Change Risk

Zambia has a burgeoning challenge in deforestation, which has been recognized for some time, in essence since the beginning of the last century (Holden 2001). There are three main causes – land clearing for “slash-and-burn” or *Chitimene* agriculture, charcoal making, and logging for high-value timber. The earlier land-use changes resulted from population growth and the *Chitimene* and *Fundikila* (“grass-mound”) farming systems, which required migration and opening up of new areas, especially when cassava and maize-fertilizer systems were implemented in Northern Zambia. These entrenched practices have caused significant environmental changes across the Zambian landscape as well as increased dependence on unsustainable supplies of natural resources, both of which increase vulnerability to climate change.

Fisheries are a critical natural resource in Zambia, but are experiencing over-exploitation and are under increasing pressure from external development activities that compromise river ecosystem services and functioning (Cowx et al. 2018). Although there is limited evidence directly linking the decline in inland fisheries in recent years to climate change, there are strong linkages to these declines with overfishing driven by human behavior change (Marshall 2012).

Deforestation and its relationship to climate sensitivity hinges on how changes in vegetation cover affect the physical and chemical components of the environment

in ways that are likely to reduce resilience to change. Deforestation, followed by agricultural disturbance, results in loss of soil organic carbon and of soil fertility (Chidumayo and Kwibisa 2003). This effect is enhanced by grassland fires (in areas where grass has replaced lost tree cover), with repeated burns also reducing soil carbon. Soil carbon is also important for enhancing soil water retention, an obvious necessity for plant growth and for maintaining growth potential. Deforestation also leads to a decline in soil moisture, which then leads to more surface energy being converted into heat at the land surface. This results in a hotter environment, which at these latitudes is damaging to crop growth and alters pest and disease organism life cycles. Ultimately, deforestation often leads to lower climate resilience.

### **Cumulative Risks and Positive Feedback Loops**

Infrastructure, socioeconomic, human health, agricultural, and environmental change risks of climate change are not independent of one another and more often than not serve to magnify each other (Mora et al. 2018). These positive feedback loops result in cumulative risk profiles across Zambia, that are deeply entrenched through the existing socio-ecological and economic systems.

Risks of climate change to infrastructure such as road closures and limited access to critical infrastructure serve to exacerbate human health risks because people cannot access hospitals and clinics. Poor health outcomes have knock-on impacts for socioeconomic livelihood activities by reducing the capacity of individuals and households to generate income and/or support social activities within a household. Such risks are closely tied to agriculture as this is the dominant livelihood activity in Zambia; for example, if people cannot work due to poor health or are forced to travel far distances to seek medical care they are often not able to tend to their crops or livestock. This further magnifies the potential risks from climate change to agricultural activities and ultimately agricultural output. Deforestation and over-harvesting of valuable and limited natural resources such as inland fisheries often result from crop failure or livestock die offs, further increasing the risks related to environmental change.

---

### **Barriers to Adaptation and Resilience Building**

There are a number of environmental, social, economic, and political barriers to effective climate change adaptation in Zambia. These barriers interact throughout complex socio-ecological systems to reduce adaptive capacities and compound the limits to adaptation throughout the country.

### **Poor Livelihood and Economic Diversification**

Most rural livelihoods are dependent on natural resources and agriculture. In other words, Zambia has not seen the structural changes in its economy that would enable a permanent shift to one dependent on secondary or tertiary economic activities such

as manufacturing and services, thus transforming from a natural resource-based economy. This is strongly aligned with broader development imperatives to shift employment from low- to high-productivity sectors.

Local markets and value chains for locally produced goods (especially agricultural products) are underdeveloped. Access to markets is low, primarily due to poor road infrastructure, impacted further by floods and extreme heat, which impact transport time and/or the modality of agricultural produce. Beneficiation processes related to output from key livelihood activities for economic development are highly underdeveloped. Thus, having livelihoods focused on a few highly vulnerable sectors and natural resources serves only to concentrate risks of climate change while simultaneously limiting the ability to adapt. Ultimately, this has resulted in low levels of livelihood and economic diversification both across primary, secondary, and tertiary economic activities as well as within primary production activities themselves.

### **High Rates of Land Degradation**

Land degradation is primarily driven by unsustainable livelihood practices that are rooted in high levels of poverty and inequality. Harvesting trees for charcoal production and for trade (e.g., for export to China) is adding to already high levels of deforestation. Zambians are often not even the main beneficiaries of revenues from tree-based trade. *Mukula* (Rosewood), is heavily harvested for timber exports to China. Local cutters receive an average price of about US\$23/cubic meter of timber harvested, while manufacturers in China pay around US\$1,000/cubic meter to importers, before any further processing is done on the exported logs (Cerutti et al. 2018).

Populations are likely to continue to diversify their livelihoods through these and other activities, such as illegal poaching, until there is a proper incentive to secure their livelihoods more sustainably. Together with climate change impacts, these activities are resulting in widespread land degradation and loss of ecosystems, biodiversity, and services that are critical to human welfare and livelihoods, such as water, fisheries, and forests.

### **Low Levels of Technical and Technological Capacities**

This aspect is evident in very low levels of adoption of new technologies, which range from alternative farming practices, such as conservation agriculture, to capacities to build new climate resilient infrastructure or to retrofit existing infrastructure to be climate resilient. The shift toward decentralization of governance in Zambia raises the challenge of meeting technical capacity needs across the levels of implementation. With this, districts across the studied provinces are limited by lack of the technical capacities needed to drive this implementation. There is thus an evolving trade-off between the necessity to decentralize decision-making power and governance structures with meeting the technical needs for livelihood and economic

diversification at the local level to adapt to existing and future impacts of climate change.

### **Inadequate Infrastructure**

Zambia's high levels of infrastructure deficits in transport, energy, Information and Communications Technology (ICT), and water and sanitation significantly impede adaptive capacities. Notably, business productivity is severely hampered by the infrastructure deficits. This reduces investments in commercial activities and limits expansion of smaller businesses, further limiting income diversification opportunities. Furthermore, 50% of the productivity gap in Zambia is attributed by firms to the state of the country's infrastructure (Foster and Dominguez 2011). Most of the productivity gap is attributed to power, followed by transport and ICT. As mentioned above, road infrastructure is insufficient and plays a pivotal role for all forms of infrastructure.

### **Entrenched Culturally and/or Policy-Driven Practices**

Zambians are often forced to default to livelihoods and coping strategies that are supported by long-standing traditional beliefs, which are in some instances supported by well-entrenched policies. For example, high cultural value is placed on cattle ownership, to the extent that farmers often refuse to sell them off during extreme droughts, in the hopes they will survive and regain health, even though the farmers cannot feed and water them. Often the cattle do not survive.

Policies can also entrench practices not conducive to climate change. For example, policy-driven maize production has increased farmer dependence on a vulnerable livelihood and its status as the country's most desired food staple (Chapoto et al. 2010). Problematically, maize is not a drought-resilient crop and yields in Zambia are quite low, also partly due to the policy emphasis on production rather than productivity (Petrie et al. 2014). Consequently, farmers are not diversifying their risks by growing additional or alternate crops, which may be more drought resilient. Nor are they considering alternate livelihoods because the culturally and policy-driven practice of maize farming is so entrenched.

### **Weak Policy Implementation**

Supportive policy frameworks that enable adaptation are relatively well established in Zambia. For example, the 2017 National Climate Change Policy details a broad approach to strengthen the implementation of adaptation measures to reduce vulnerability to climate change, which supports and builds on the objectives outlined in the 7th National Development Plan. However, these policies are generally not effectively applied or fully implemented due to a number of related barriers, such

as breadth of technical capacity, conflicting discourse on development objectives, lack of financing opportunities, and weak institutional arrangements (Romdhani et al. 2018). This is particularly true in rural areas, where institutional arrangements and related enforcement mechanisms are relatively weak and government institutions are poorly capacitated; yet people in these areas are the most vulnerable to the impacts of climate change.

## **Persistent Inequalities**

Gender inequality and gender-based violence persists despite transversal policy. Women lack access to land in comparison to men, under customary law that disadvantages women in terms of land allocation. This compromises agricultural productivity and food security, particularly in situations where women have the responsibility over daily household welfare without decision-making powers over land and land use, and in the face of little access to disposable income. With this, female farmers tend to have even lower access than men to agricultural inputs.

Even if there were greater opportunities for livelihoods and incomes beyond natural resource-based sectors, education, a key indicator of adaptive capacity, is low in the studied provinces. This limits people's access to opportunities, particularly affecting women. Inequalities are also highly evident in access to safe water, electricity, and public health services, which tends to be much lower in rural areas making people less able to adapt to the impacts of climate change. Ultimately, this reduces the adaptive capacity of these individuals and communities and reduces their opportunities to diversify.

## **Cumulative Barriers and Positive Feedback Loops**

Similar to the cumulative nature of the climate change risk pathways, the above-mentioned barriers to adaptation can also create positive feedback loops that serve to reinforce these barriers and ultimately limit resilience building opportunities (Shackleton et al. 2015). A key example from the Zambian context relates to both weak policy implementation and the myopic culturally entrenched and policy-driven practices. Agriculture-based livelihoods being culturally entrenched and together driven by centralized blanket maize cultivation incentives create more significant barriers to effective adaptation when combined with poor implementation of climate change policies. Moreover, traditional livelihoods serve to reinforce the status quo around traditional gender roles and thus further entrench the persistent inequalities. Moreover, traditional livelihood practices and high levels of inequality and poverty drive unsustainable land-use practices and ultimately lead to degradation. This phenomenon is heightened due to the increasing nature of crop failures and livestock die offs due to the impacts of climate change.

Given that low population densities and high travel distances necessitate greater per capita investment for infrastructure construction (Chapman et al. 2013), the

widespread nature of rural and subsistence-based livelihoods across the country compound the difficulty of infrastructure provision. The same logic applies to the adoption of novel technologies and livelihood practices as well as the opportunities to access alternative markets and economies.

---

## **Toward Improved Climate Change Adaptation**

Climate change risk pathways and barriers to adaptation manifest through a complex network of social, economic, and environmental feedback loops, often resulting in positive feedback loops that intensify the initial perceived risk of a particular climate hazard or stressor. These potentially antagonistic relationships between different risk pathways and socioeconomic barriers to adaptation highlight the complexity of the interdependent nature of socio-ecological systems in Zambia. The benefits of developing adaptation responses that focus on individual climate change risk pathways or barriers will be abated due to the complex synergistic and antagonistic feedback loops that characterize these systems. Thus, these complex interactions highlight the need for systematic responses to minimize risks and overcome the barriers.

In Zambia, the complex and emergent properties of the socio-ecological systems, combined with their strong dependency on climate systems, elucidate the intrinsic and inextricable relationship between climate change and sustainable development. Thus, effective adaptation responses need to take a systematic approach that attempts to address the myriad of complex climate change risks concurrently with existing barriers to adaptation. Kim et al. (2018) show that community social and ecological climate change risk characteristics were reduced by higher levels of social capital combined with local proactive planning and policy measures focused on systematic responses to cumulative exposure. The notion of an integrated and systematic response to stressors and shocks on socio-ecological systems and related economic activities is widely considered effective, whether or not these external stressors and shocks are related to climate change or not (Cinner and Barnes 2019; Fedele et al. 2019; Hafezi et al. 2018).

## **Maladaptation Potential**

Responding to a myriad of climate change threats across Zambia requires both increased resilience to short- to medium-term shocks (e.g., floods and droughts) combined with sustained and more gradual adaptation to climate change (temperature rise and seasonal rainfall changes) across systems and society. Moreover, this necessitates rigorous assessments of maladaptation potential for proposed interventions. Much of the onus for this falls on government institutions and the Zambian governance framework because the role of the developmental state is to balance social development with economic growth in a sustainable manner. However, maladaptation risks are high and generic approaches to diversifying livelihoods do

not always provide the best options to complex risk profiles associated with poverty, climate change, and environmental degradation.

Maladaptive actions may lead to increased risks of adverse climate-related outcomes (IPCC 2018). Thus, understanding the potential for maladaptation is critical for planning and budgeting for adaptation interventions. Zambia faces enormous opportunities to improve livelihoods and living standards through adaptation; however, the significant scope of the opportunity raises the likelihood of maladaptive outcomes.

Improving road infrastructure, for example, has its own risks, despite the notable potential for positive sustainable development and climate change adaptation outcomes. In many parts of Zambia, such as Western Province, illegal tree harvesting of species such as Mzauli (African rosewood – *Guibourtia coleosperma*) is taking place, with the timber being exported through Namibia. This is leading to a decline in this species. Improved roads into these areas could facilitate increased penetration of illegal tree fellers.

## Is Livelihood and Economic Diversification the Answer?

Livelihood and economic diversification are regularly identified as a key adaptation option given the current socioeconomic state of Zambian populations and communities and the current and projected impacts of climate change (Petrie et al. 2018). The dominant discourse around adaptation in Zambia is focused on agriculture-based livelihoods, which are facing the greatest risks from climate change. Currently, in response, adaptation interventions are focused on transitions to (and between) different forms of conservation agriculture, crop diversification, and a combination of farm and nonfarm activities such as seasonal fishing and charcoal production (Loison 2015; Romdhani et al. 2018).

Zambia's favorable agro-climatic conditions are suitable for producing a diverse variety of livestock and crops; however, legacy blanket policies promoting the cultivation and consumption of maize have limited these opportunities significantly. In 2015, ±98% of smallholder households were cultivating maize, while it is estimated that more than half of the land under crop production in Zambia is devoted to maize (CSO 2015). Moreover, Mofya-Mukuka and Hichaambwa (2018) found that government input subsidies and direct market support for maize have negatively affected crop diversification by rural households. Additionally, compared to neighboring countries in the region, Zambia's level of crop diversification is low (as measured by the Simpson Index of Diversification = ±0.37) (World Bank 2018). Despite this the potential for diversification has been shown to be good. Alfani et al. (2019) found in Zambia that general diversification actions such as livestock and income diversification and the adoption of agro-forestry as an alternative economic activity served to moderate the impact of a recent severe drought. Interestingly, it was also found that some agro-ecological practices such as minimum soil disturbance was not effective in moderating any yield and income effects of the drought. Additionally, Wineman and Crawford (2017) demonstrate that given the current set



of available diversification options, autonomous on-farm adaptation will not be sufficient to offset the negative yield effects of climate change.

Combined with the notable vulnerability of maize production to projected climate change in Zambia (Wineman and Crawford 2017; Petrie et al. 2014), the rationale for diversification to improve income and/or food security is clear. However, the perceived benefits of diversification might not always materialize on the ground, as the enabling environment to support such diversification is weak. Loison (2015) emphasizes that it is only the relatively better-off smallholders with sufficient assets who achieve successful livelihood diversification; and thus, associated increases in income and wealth based on livelihood diversification are yet to show notable benefits for smallholder farmers that are implementing diversified livelihood activities. The same argument holds in relation to improving climate resilience through livelihood diversification. Climate change vulnerability in Zambia is largely a function of people's poor ability to adapt (i.e., adaptive capacity), which is driven by high levels of poverty and a lack of access to basic services and supporting infrastructure (Petrie et al. 2018).

Despite multiple proponents of diversification as a key strategy for climate-smart agriculture in Zambia (Arslan et al. 2018), there is little empirical research detailing the possible risks of diversification. Moreover, risks of promoting diversification are exacerbated by the weak enabling environment. For example, diversifying agricultural practices requires knowledge, skills, and inputs to grow multiple types of crops and/or rear multiple different types of livestock. Not only could this cost more in the short run; there is also a greater risk of making mistakes. Diversification can also lead to localized competition for markets, leading to possible conflicts. Importantly, promoting over-diversified livelihood activities might limit opportunities to upscale by taking advantage of economies of scale through access more well developed markets and value chains. These risks might exacerbate the cycles of poverty that underpin climate change vulnerability in Zambia.

It is clear that livelihood diversification presents significant opportunities and challenges, which means it should not be viewed as an adaptation panacea in low income settings. People will naturally adapt and diversify, where livelihood and/or income opportunities are better. Hence there is a clear need for dedicated policy and governance efforts to systematically target, support, and incentivize context-specific livelihood diversification opportunities that are harmonized across competing developmental objectives. Bhatta et al. (2015) highlight that livelihood and diversification strategies need to be tailored to both localized climatic and non-climatic resources alike to minimize risks and facilitate the lowest-cost (social and economic) transition to climate resilience.

---

## Conclusions and Recommendations

The system- and society-wide impacts of climate change in Zambia require transformational change in sustainable development. Zambia's dependence, for example, on agriculture for its economy and for livelihoods, places the country and its

populations at high risk to climate change. The related national policies, such as the incentivization of maize production, do not capture the localized livelihood contexts and climate risk profiles. The link between climate change and sustainable development in Zambia is inextricable, however, and thus these two concepts should not be viewed in isolation from one another.

Livelihood diversification was identified as the central adaptation option across Zambia, despite little empirical research detailing possible risks of diversification. The dominant adaptation discourse is focused specifically on diversifying within agriculture-based livelihoods. However, as all agricultural activities are impacted by climate change, diversification also needs to be explored in value added or alternative sectors. With this, a weak policy framework and enabling environment is exacerbating cycles of poverty that underpin climate change vulnerability in Zambia. Moreover, maladaptation risks of existing diversification interventions are high as generic approaches often do not provide suitable options to complex and localized risk profiles.

It is evident that there is a strong need to diversify both within and outside of the agriculture sector, but how this is done will be critical. Thus, the authors recommend the development of a detailed spatial assessment of the economic, environmental, and social complexities that contribute to differing levels of climate change vulnerability throughout Zambia and how these contribute to or detract from realizing national sustainable development objectives. Specifically, there is a need to focus on harnessing the positive feedback loops for systematic change to build resilience, while minimizing the dominant risk pathways and eliminating persistent barriers that enable positive feedback loops driving vulnerability to climate change.

First, this will necessitate a detailed examination of a selected range of pathways for alternate crops, livestock farming, fisheries exploitation, and secondary and tertiary services to understand key elements ranging from production to market economics across the various value chains. In this way it will be possible to establish which livelihoods are most appropriate for different areas, and how these might be influenced by projected changes in climate. It will also be important to ascertain how these can best be initiated and sustained from initial development onward in a way that aligns with national development objectives and policy priorities. Potential maladaptation risks of diversification can be addressed through continued stakeholder engagement and incremental development of diversification incentives, penalties, and other governance and/or policy support mechanisms.

To ensure a sustainable transition toward climate resilient and compatible development in Zambia, this systematic approach toward facilitating diversification throughout the economy should be supported by complementary approaches toward land-use and natural resources management, urban planning and infrastructure development. Future research endeavors in the region should focus on supporting this type of holistic approach by developing the evidence-base for change. Specifically, there is a need for a greater understanding of the complex interactions and emergent properties of socio-ecological systems in low-income settings that can inform policy direction at the local scale. This applies specifically to the derivation and classification of combined climate change and developmental

risks, how these accumulate in a system and how best these can be addressed given existing resource constraints.

Additionally, future research should also focus on developing innovative densified development models in low-income settings, which can balance the need to simultaneously realize social, economic, and environmental development imperatives. Particular emphasis should be given to the potential role of nature-based solutions and the integration of ecological and traditional gray infrastructure. Ultimately, this approach toward evidence-led policy implementation will assist to minimize risks of upscaling livelihood and economic diversification actions, while continuing to facilitate an effective transition toward climate resilience through planned and incremental change.

---

## References

- AfDB (2019) National climate change profile: zambia. Available: <https://www.afdb.org/en/documents/zambia-national-climate-change-profile>
- Alfani F, Arslan A, McCarthy N, Cavatassi R, Sitko N (2019) Climate-change vulnerability in rural Zambia: the impact of an El Niño-induced shock on income and productivity. *FAO agricultural development economics working paper 19-02*. FAO, Rome, p 41
- Antwi-Agyei P, Dougill A, Agyekum T, Stringer L (2018) Alignment between nationally determined contributions and the sustainable development goals for West Africa. *Clim Pol* 18:1–17. <https://doi.org/10.1080/14693062.2018.1431199>
- Arslan A, Cavatassi R, Alfani F, McCarthy N, Lipper L, Kokwe M (2018) Diversification under climate variability as part of a CSA strategy in rural Zambia. *J Dev Stud* 54:457–480. <https://doi.org/10.1080/00220388.2017.1293813>
- Berry HL, Bowen K, Kjellstrom T (2010) Climate change and mental health: a causal pathways framework. *Int J Public Health* 55(2):123–132
- Bhatta GD, Aggarwal PK, Shrivastava A (2015) Livelihood diversification and climate change adaptation in Indo-Gangetic plains: implication of rainfall regimes. *J Agric Environ* 16:77–94. <https://doi.org/10.3126/aej.v16i0.19841>
- Bwalya SM (2010) Climate change in Zambia: opportunities for adaptation and mitigation through Africa bio-carbon initiative. Center for International Forest Research Southern Africa, Lusaka
- Caminade C, Kovats S, Rocklov J, Tompkins AM, Morse AP, Colón-González FJ, Stenlund H, Martens P, Lloyd SJ (2014) Impact of climate change on global malaria distribution. *PNAS* 111:3286–3291. <https://doi.org/10.1073/pnas.1302089111>
- Cerutti PO, Gumbo D, Moombe K, Schoneveld G, Nasi R, Bourland N, Weng X (2018) Informality, global capital, rural development and the environment: Mukula (rosewood) trade between China and Zambia. Research report. IIED/CIFOR, London/Lusaka
- Chapman L, Azevedo JA, Prieto-Lopez T (2013) Urban heat & critical infrastructure networks: a viewpoint. *Urban Clim* 3:7–12. <https://doi.org/10.1016/j.uclim.2013.04.001>
- Chapoto A, Govereh J, Haggblade S, Jayne TS (2010) Staple food prices in Zambia. Food Security Collaborative working papers 58556. Michigan State University, Department of Agricultural, Food, and Resource Economics
- Chidumayo EN, Kwibisa L (2003) Effects of deforestation on grass biomass and soil nutrient status in miombo woodland, Zambia. *Agric Ecosyst Environ* 96:97–105. [https://doi.org/10.1016/S0167-8809\(02\)00229-3](https://doi.org/10.1016/S0167-8809(02)00229-3)
- Cinner JE, Barnes ML (2019) Social dimensions of resilience in social-ecological systems. *One Earth* 1:51–56. <https://doi.org/10.1016/j.oneear.2019.08.003>

- Cowx IG, Lungu A, Kalonga M (2018) Optimising hydropower development and ecosystem services in the Kafue River, Zambia. *Mar Freshw Res* 69:1974–1982. <https://doi.org/10.1071/MF18132>
- CSO (2015) Rural Agricultural Livelihood Survey (RALS). Central Statistical Office, Ministry of Agriculture and Cooperatives and Indaba Agricultural Policy Research Institute. CSO, MAL, IAPRI, Lusaka
- Dosio A (2017) Projection of temperature and heat waves for Africa with an ensemble of CORDEX Regional Climate Models. *Clim Dyn* 49(1):493–519. <https://doi.org/10.1007/s00382-016-3355-5>
- Engelbrecht F, Adegoke J, Bopape MJ, Naidoo M, Garland R, Thatcher M, McGregor J, Katzfey J, Werner M, Ichoku C, Gatebe C (2015) Projections of rapidly rising surface temperatures over Africa under low mitigation. *Environ Res Lett* 10:085004. <https://doi.org/10.1088/1748-9326/10/8/085004>
- England MI, Dougill AJ, Stringer LC, Vincent KE, Pardoe J, Kalaba FK, Mkwambisi DD, Namaganda E, Afionis S (2018) Climate change adaptation and cross-sectoral policy coherence in southern Africa. *Reg Environ Change* 18:2059–2071. <https://doi.org/10.1007/s10113-018-1283-0>
- EPDC (2012) Zambia – making sense of data to improve education for development. Education Policy Data Center. <https://www.epdc.org/country/zambia>
- Fedele G, Donatti CI, Harvey CA, Hannah L, Hole DG (2019) Transformative adaptation to climate change for sustainable social-ecological systems. *Environ Sci Pol* 101:116–125. <https://doi.org/10.1016/j.envsci.2019.07.001>
- Fischer AP (2019) Adapting and coping with climate change in temperate forests. *Glob Environ Chang*. <https://doi.org/10.1016/j.gloenvcha.2018.10.011>
- Foster V, Dominguez C (2011) Zambia’s infrastructure: a continental perspective. The World Bank policy research working paper 5599. The World Bank, Washington, DC
- Grüneis H, Penker M, Höferl KM, Schermer M, Scherhauser P (2018) Why do we not pick the low-hanging fruit? Governing adaptation to climate change and resilience in Tyrolean mountain agriculture. *Land Use Policy* 79:386–396
- Haasnoot M, van Aalst M, Rozenberg J, Dominique K, Matthews J, Bouwer LM, Kind J, Poff NL (2019) Investments under non-stationarity: economic evaluation of adaptation pathways. *Clim Chang* 161:1–13
- Hafezi M, Sahin O, Stewart RA, Mackey B (2018) Creating a novel multi-layered integrative climate change adaptation planning approach using a systematic literature review. *Sustainability* 10:4100. <https://doi.org/10.3390/su10114100>
- Hallegatte S, Shah A, Lempert R, Brown C, Gill S (2012) Investment decision making under deep uncertainty-application to climate change. The World Bank, Washington, DC
- Hamududu B, Ngoma H (2018) Impacts of climate change on water availability in Zambia: implications for irrigation development. Technical paper number 7. Indaba Agricultural Policy Research Institute (IAPRI), Lusaka
- Hatfield JL, Prueger JH (2015) Temperature extremes: effect on plant growth and development. USDA Research and Programs Extreme Events. *Weather Clim Extremes* 10:4–10. <https://doi.org/10.1016/j.wace.2015.08.001>
- Holden S (2001) A century of technological change and deforestation in the miombo woodlands of Northern Zambia. In: Angelsen A, Kaimowitz D (eds) *Agricultural technologies and tropical deforestation*. CABI, New York, pp 251–270
- IPCC (2018) *Global warming of 1.5 °C: an IPCC special report on the impacts of global warming of 1.5 °C above pre-industrial levels and related global greenhouse gas emission pathways, in the context of strengthening the global response to the threat of climate change, sustainable development, and efforts to eradicate poverty*. Intergovernmental Panel on Climate Change, Geneva
- Juhola S, Glaas E, Linnér BO, Neset TS (2016) Redefining maladaptation. *Environ Sci Pol* 55:135–140

- Kaluba D (2014) Republic of Zambia pilot program for climate resilience: climate resilience and economic development. <http://www.oecd.org/env/cc/Session%204%20-%20Kaluba%20Climate%20Resilience%20and%20Economic%20Growth.pdf>
- Kim H, Marcouiller DW, Woosnam KM (2018) Rescaling social dynamics in climate change: the implications of cumulative exposure, climate justice, and community resilience. *Geoforum* 96:129–140. <https://doi.org/10.1016/j.geoforum.2018.08.006>
- Kupika LO et al (2019) Local ecological knowledge on climate change and ecosystem-based adaptation strategies promote resilience in the Middle Zambezi Biosphere Reserve, Zimbabwe. Wildlife conservation in tropical savanna ecosystem. *Scientifica* 2019:3069254. <https://doi.org/10.1155/2019/3069254>
- Loison SA (2015) Rural livelihood diversification in sub-Saharan Africa: a literature review. *J Dev Stud* 51:1125–1138. <https://doi.org/10.1080/00220388.2015.1046445>
- Magnan AK, Schipper E, Burkett M, Bharwani S, Burton I, Eriksen S, Gemenne F, Schaar J, Ziervogel G (2016) Addressing the risk of maladaptation to climate change. *WIREs Clim Change* 7:646–665. <https://doi.org/10.1002/wcc.409>
- Marshall BE (2012) Does climate change really explain changes in the fisheries productivity of Lake Kariba (Zambia-Zimbabwe)? *Trans R Soc S Afr* 67:45–51. <https://doi.org/10.1080/0035919X.2012.694083>
- Maure G et al (2018) The southern African climate under 1.5 °C and 2 °C of global warming as simulated by CORDEX regional climate models. *Environ Res Lett* 13(6):065002. <https://doi.org/10.1088/1748-9326/aab190>
- Mofya-Mukuka R, Hichaambwa M (2018) Livelihood effects of crop diversification: a panel data analysis of rural farm households in Zambia. *Food Sec* 10:1449–1462
- Mora C, Spirandelli D, Franklin EC, Lynham J, Kantar MB, Miles W, Smith CZ, Freel K, Moy J, Louis LV, Barba EW, Bettinger K, Frazier AG, Colburn Ix JF, Hanasaki N, Hawkins E, Hirabayashi Y, Knorr W, Little CM, Emanuel K, Sheffield J, Patz JA, Hunter CL (2018) Broad threat to humanity from cumulative climate hazards intensified by greenhouse gas emissions. *Nat Clim Chang* 8:1062–1071. <https://doi.org/10.1038/s41558-018-0315-6>
- Nhamo L, Ndlela B, Nhemachena C, Mabhaudhi T, Mpendeli S, Matchaya G (2018) The water-energy-food nexus: climate risks and opportunities in southern Africa. *Water* 10(5):567. <https://doi.org/10.3390/w10050567>
- Paeth H et al (2010) Meteorological characteristics and potential causes of the 2007 flood in sub-Saharan Africa. *Int J Climatol* 31(13):1908–1926. <https://doi.org/10.1002/joc.2199>
- Petrie B, Chapman A, Midgley A, Parker R (2014) Risk, vulnerability and resilience in the Limpopo River Basin system: climate change, water and biodiversity – a synthesis. For the RESILIM Program, USAID. OneWorld Sustainable Investments, Cape Town
- Petrie B, Rawlins J, Perkins D, Lumbroso D, Chapman A (2018) Climate change risk and vulnerability assessment in Luapula, Muchinga, Northern and Western Provinces of Zambia. OneWorld Sustainable Investments, Cape Town
- Rawlins J, Petrie B, Gerhard M, Filipova A (2018) Towards cooperative transboundary environmental management in SADC: politics and harmonisation. Political drivers for sustainable ecosystems: building peace. World Water Week, August 2018, Stockholm
- Romdhani A, Coll Besa M, Scott D, Bharwani S (2018) Zambia's adaptation to climate change. Stockholm Environment Institute, Stockholm
- Samuels F, Ndubani P, Walker D, Simbaya J (2015) Baseline study: Stamping Out and Preventing Gender Based Violence (STOP GBV) in Zambia. ODI Frontiers Research Group, ODI, Blackfriars
- Shackleton S, Ziervogel G, Sallu S, Gil T, Tschakert P (2015) Why is socially-just climate change adaptation in sub-Saharan Africa so challenging? A review of barriers identified from empirical cases. *WIREs Clim Change* 6:321–344. <https://doi.org/10.1002/wcc.335>
- Smith KR, Woodward A, Campbell-Lendrum D, Chadee DD, Honda Y, Liu Q, Olwoch JM, Revich B, Sauerborn R (2014) Human health: impacts, adaptation, and co-benefits. In: Field CB, Barros VR, Dokken DJ, Mach KJ, Mastrandrea MD, Bilir TE, Chatterjee M, Ebi KL, Estrada YO,

- Genova RC, Girma B, Kissel ES, Levy AN, MacCracken S, Mastrandrea PR, White LL (eds) Climate change 2014: impacts, adaptation, and vulnerability. Part A: global and sectoral aspects. Contribution of working group II to the fifth assessment report of the Intergovernmental Panel on Climate Change. Cambridge University Press, Cambridge, UK/New York, pp 709–754
- Spalding-Fecher R, Joyce B, Winkler H (2017) Climate change and hydropower in the Southern African Power Pool and Zambezi River Basin: system-wide impacts and policy implications. *Energy Policy* 103:84–97. <https://doi.org/10.1016/j.enpol.2016.12.009>
- Taylor CM et al (2017) Frequency of extreme Sahelian storms tripled since 1982 in satellite observations. *Nature* 544(7651):475–478. <https://doi.org/10.1038/nature22069>
- Terblanche JS, Clusella-Trullas S, Deere JA, Chown SL (2008) Thermal tolerance in a south-east African population of the tsetse fly *Glossina pallidipes* (Diptera, Glossinidae): implications for forecasting climate change impacts. *J Insect Physiol* 54:114–127. <https://doi.org/10.1016/j.jinsphys.2007.08.007>
- Weber T et al (2018) Analysing regional climate change in Africa in a 1.5 °C, 2 °C and 3 °C global warming world. *Earth's Future* 6:1–13. <https://doi.org/10.1002/2017ef000714>
- Whitney CK, Ban NC (2019) Barriers and opportunities for social-ecological adaptation to climate change in coastal British Columbia. *Ocean Coast Manag* 179:104808
- Wineman A, Crawford EW (2017) Climate change and crop choice in Zambia: a mathematical programming approach. *NJAS Wagening J Life Sci* 81:19–31. <https://doi.org/10.1016/j.njas.2017.02.002>
- World Bank (2018) Productive diversification of African agriculture and its effects on resilience and nutrition. World Bank, Washington, DC
- World Bank (2019) Climate change knowledge portal: zambia. Available: <https://climateknowledgeportal.worldbank.org/country/zambia>
- ZINDC (2015) Zambia's Intended Nationally Determined Contribution (INDC) to the 2015 Agreement on Climate Change. Available: <http://www4.unfccc.int>

**Open Access** This chapter is licensed under the terms of the Creative Commons Attribution 4.0 International License (<http://creativecommons.org/licenses/by/4.0/>), which permits use, sharing, adaptation, distribution and reproduction in any medium or format, as long as you give appropriate credit to the original author(s) and the source, provide a link to the Creative Commons license and indicate if changes were made.

The images or other third party material in this chapter are included in the chapter's Creative Commons license, unless indicated otherwise in a credit line to the material. If material is not included in the chapter's Creative Commons license and your intended use is not permitted by statutory regulation or exceeds the permitted use, you will need to obtain permission directly from the copyright holder.





# Gendered Vulnerability to Climate Change Impacts in Selected Counties in Kenya

# 100

Daniel M. Nzenya and John Kibe Maguta

## Contents

Introduction and Background .....	2046
Overview of Global Perspectives of Climate-Induced Migration .....	2047
Climate-Induced Migration in Kenya: Causes and Implications .....	2049
Materials and Methods .....	2050
Study Setting .....	2051
Data Analysis and Presentation of Results .....	2051
Results and Discussions .....	2052
Climate Change Affects Women's Livelihood Differently from That of Men: Empirical Evidence from the Study .....	2052
Ways in Which Experiences of Climate Change-Induced Migration Differed for Men and Women .....	2055
Measures by County Governments to Assist Communities Cope with Climate Change-Induced Migration .....	2056
Measures by Nongovernmental Agencies to Assist Communities Cope with Climate Change-Induced Migration .....	2058
Lessons Learned, Study Limitations, and Recommendations for Future Research .....	2058
Conclusion .....	2060
References .....	2060

## Abstract

Extreme climate change events such as frequent and prolonged droughts or floods associated with climate change can be very disruptive to peoples' livelihoods particularly in rural settings, where people rely on the immediate environment for livelihood. Shocks in the people's livelihoods can trigger diverse responses that include migration as a coping or adaptation strategy. Migration takes many forms

---

D. M. Nzenya (✉)  
Department of Social Sciences, St Paul's University, Limuru, Kenya  
e-mail: [dmuasya@spu.ac.ke](mailto:dmuasya@spu.ac.ke)

J. K. Maguta  
Faculty of Social Science, St Paul's University, Limuru, Kenya

depending on the context and resources availability. Very few studies in Kenya have used qualitative analysis to bring up women's voices in relation to gender, climate change, and migration, especially along hydrological gradient. This chapter presents results of qualitative research conducted from 58 participants in 2018 in three counties in Kenya, namely, Kiambu County, Machakos, and Makeni. The study sought to examine gender perceptions related to climate-induced migration, that is: whether climate change is perceived to be affecting women's livelihood differently from that of men; examine in what ways experiences of climate induced migration differed for men and women; explore perceptions on the county government efforts to cope with climate-induced migration; and examine perceptions of the role of nongovernmental agencies in helping citizens cope with climate change. From the results obtained on ways in which climate change affected women livelihoods more than men had four themes: (1) women exerted more strain in domestic chores, child/family care, and in the farm labor; (2) women also experienced more time demands. The sources of water and firewood were getting more scarce leading to women travel long distances in search to fetch water and firewood; (3) reduced farm yields, hence inadequate food supply; and (4) the effects of time and strain demands on women was a contributory factor to women poor health and domestic conflicts. Several measures that the county government could take to assist women to cope with climate change-induced migration had five themes which include the following: (1) developing climate change mitigations, and reducing deforestation; (2) increasing water harvesting and storage; (3) develop smart agriculture through the use of drought-resistant crops and drought mitigation education; (4) encourage diversification of livelihoods; and finally (5) providing humanitarian assistance to the most vulnerable populations such as orphans and the very poor. Thirdly, the measures mentioned that NGO's could take to assist rural communities to cope with climate change-induced migration did not vary significantly from those mentioned for county government, except probably for a new theme of *increasing* advocacy for climate adaption policies.

---

### Keywords

Climate change-induced migration · Hydrological gradient · Gendered vulnerabilities · Rural livelihoods · Kenya

---

## Introduction and Background

Climate change poses one of the greatest challenges to rural livelihoods in the Sub-Saharan Africa (SSA). Sub-Saharan Africa is among the regions of the world where majority of people still reside in the rural areas. Millions of households in the rural populations rely on rain-fed small-scale subsistence agriculture (Kalungu et al. 2013). Subsistence agriculture has continued to face many sustainability challenges in the last 10 years, namely, worsening land degradation, declining farm outputs due to declining parcel of land associated with continuing subdivision due to rising population, inaccessibility to farm drought resistance seed crops, extreme climate



change events, particularly more frequent and prolonged droughts (Kalungu et al. 2013). Because rural population has risen during the last 15 years, increasing demands for farming and settlement has pushed communities to marginal and ecologically fragile lands, for instance, steep hill slopes, river banks, arid and semiarid areas (Ngugi et al. 2015). Poor land use practices have further exacerbated the continent's problem of soil erosion and desertification (Ngugi et al. 2015), further compounding population's vulnerability to extreme climate events such as droughts. It is estimated that climate change is partly responsible for the rural-urban migration in the SSA region, as people flee to towns and cities to pursue alternative livelihoods (Barrios et al. 2006; Hassan and Tularam 2018).

According to the Intergovernmental Panel on Climate Change, there is need to put in place mitigation and adaptation measures (Intergovernmental Panel on Climate Change 2018). It is because of climate change threats to human life that the United Nations took quick steps that resulted into holding conventions to mitigate climate change effects. According to the United Nations Framework Convention on Climate Change (UNFCCC) report developed from workshops held in 2006–2007 in Africa, Asia, and Latin America, all nations and people have a stake in reversing climatic changes (United Nations Framework Convention on Climate Change 2006). The UNFCCC paints a worrying report with claims that the developing countries are feeling the effects of climate change more than the developed ones. While developed countries have better and advanced coping mechanisms, the developing ones rely on crude means that leave them suffering the wrath of nature emanating from drought, excessive heat, and floods, and so on (Hurd and Smith 2004). There is need to put in place mitigation and adaptation measures as well as doing all that can be done to ensure the ecosystem remains balanced and conserved.

The objectives of this chapter are to: (1) examine if climate change was affecting women's livelihood differently from that of men; (2) in what ways climate-induced migration differed for men and women; and (3) to examine the measures county government and nongovernmental agencies were taking assist communities cope with climate-induced migration.

## **Overview of Global Perspectives of Climate-Induced Migration**

Extreme climate change events interact with many factors to trigger human migration. For instance, the rising trends in climate related disasters, such as severe and prolonged droughts, floods, in different regions of the world have forced people to migrate for safety or for survival. Van der Land and Hummel (2013) has argued that there has been a tendency of low rainfall forcing man to degrade the land. When land is degraded, the environment is affected even more. Further, planning for people has become harder. It is hard to allocate resources to populations that keep moving from one region to another when threatened by the same weather the populations have contributed to make unfriendly. When populations migrate, they further strain the resources of their new areas of settlement. Kartiki (2011) has expressed concern that the ensuing migrations are likely to increase conflicts and political stability. This, the

author argues, will result from the struggle over the scarce resources and probably reshaping of geographical boundaries. International conflicts are likely to increase when countries share boundaries.

Chindarkar (2012) has lamented that climate change though painful to all leaves the female gender suffering more in comparison to men. The author argues that women are disadvantaged in terms of property ownership and getting education making them poorer. Failure to give women good education and allow them access to natural resources leaves them with little options to deal with hazards of climate change among other outcomes that include poor health and forced migrations. There are reduced economic activities that are based on natural resources resulting in food insecurity among other things. Climate change induced displacements of people as well as migrations and relocation have continued to take place making the UN to take climate change as an agenda that calls for urgent action (United Nations 2016). Several agencies including the United Nations have called upon organizations and individual countries to have measures in place to address displacement and migration of people (United Nations 2016). However, despite the calls and efforts of the UN, migrations and displacements of people have been on the increase (Hassan and Tularam 2018).

Population movements occasioned by climate change are feared to adversely affect the poor and the vulnerable that have low coping mechanisms. Chindarkar (2012) has opined that since adaptation to and coping with climate change are gendered, women will continue to suffer as they have little income and access to natural resources in comparison to their male counterparts. Reduced access to food and water lays a bigger burden on women. As evidenced in the case of Chitwan Valley in Nepal, women are in most cases the primary collectors of the various provisions required by family members. Citing the case of Sonora in Mexico, the author states that the reduction of water affected the food processing industry forcing men to migrate to towns. The outcome was increase in the workload of women who were left with the burden of tending for families without the men who had migrated. In a similar trend, internal migrations have taken place quite to a large extent in the republics of Kiribati and Tuvalu as a result of induced climate change (Hassan and Tularam 2018). Majority of the people especially women in the Kiribati and Tuvalu rely almost entirely on agricultural-related activities.

The gender divide puts a heavier burden on women who are tasked with looking for water and much more often searching for food. The socially constructed gender differences heap the obligations and the burden of caregiving on women. Since the economic muscle needed to acquire food and water is in many cases lacking, as men monopolize this, women are left with no option but to trek long distances looking for the commodities. Kolmannskog (2009) in a study conducted in Somalia and Burundi has stated that women who are left behind by their husbands face another fear of being chased away by families or relatives of their husbands. When husbands migrate in search of better pastures for their animals, women and children are left behind with relatives.

This has been the trend in Mexico where apart from destroying plants and aquatic life, health has been affected through water pollution and sedimentation. Studies conducted in Bihar and Uttarakhand in India have confirmed that the people who have limited access to resources are more vulnerable and suffer more from climate change effects. Adding their voices to the debate on climate change-induced

migrations, Waldinger and Fankhauser (2015) have opined that it increases incentives to migrate. Inability to cope with induced climate change has called for emergency relief and security for those affected (Serdeczny et al. 2017). The authors further argue that internal displacements have resulted in greater risks especially sexual and gender-based violence for women. The latter authors have claimed that when people have to move as a result of weather, the dressing code has compounded the problem like what happened to the Indian women during the Indian Ocean tsunami in 2004. The mode of dressing for Indian women is not suited for walking fast and covering long distances. Further, climate-induced migrations and displacements often lead to breaking of social networks and psychological impacts that are lasting. The authors here have argued that women feel the impact of climate change-induced migrations more deeply. In many cases, they are left with no choice but to think of themselves as well as their entire families. The situation becomes even worse for women as they are rarely allowed direct access to relief food and other emergencies due to cultural constraints. The scenario portrays a potential risk of women falling victims of sexual exploitation or even worse to be trafficked. In countries like Bangladesh and Philippines, due to their low education, women are subjected to low-working paying jobs with long working hours. They are employed as domestic house-helpers who have to contend with mistreatments in order to earn bread. Climate-induced migration is not only dangerous but has also turned into a poverty trap (Rahman 2013).

Climate change has forced people to adapt into new cultures in order to survive. Chindarkar (2012) has cited the case of Bangladesh women who have migrated to India. For fear of detection and eventual deportation, many have adorned Hindu religious markers especially on their foreheads.

In Mali and Senegal both of which are in Africa, climatic changes have adversely affected subsistence farming and livestock rearing. Since this Sahel region of West Africa has majority of the people relying on the rains that have been declining, migration has become a common phenomenon (van der Land and Hummel 2013). With a good number being illiterate or semiliterate, farming has been the only way to as they cannot be absorbed in gainful employment that require skills. Waldinger and Fankhauser (2015) have claimed that people involved in the agricultural sector in developing countries will continue suffering climate shocks like droughts and flooding (also, see IPCC 2018). These are attributed to weak financial muscle and use of low technology.

## **Climate-Induced Migration in Kenya: Causes and Implications**

Like the rest of the world, effects of climate change are being felt in Kenya. This is proved by the erratic and unpredictable weather patterns. Cuni-Sanchez et al. (2019) content that the amount of rainfall, fog, and temperature has witnessed serious variations in the last few decades. Rain seasons have changed making it hard to predict the weather and prepare land in good time for farmers. With the high reliance on rain-fed agriculture, variability of rains has threatened food security and complicated lives mainly in rural areas. Droughts and flooding are now a common thing with crops being destroyed. Desertification has increased making life even tougher

especially for pastoralists whose livestock have faced grass shortages. Livelihoods have been destroyed with vulnerability increasing by the day. Migrations mainly to urban centers for wage employment especially by men have been taken as the option by some of the affected. Like in other countries, women have been left behind to cater for the families (IPCC 2018).

Climate variability in Kenya like the rest of the world has been blamed largely on human activities. As Sheikh (2017) has argued in a study of Dadaab area of North Eastern Kenya, human-related activities have led to stiff competition over resources which in turn has led to increased conflicts. The increased conflicts have compounded [the problem created the?] movement of people from one place to another. Further, the internally displaced persons in the country are exposed to other vices that include sexual and gender-based violence, dependency, instability, and living in fear as the future remains uncertain. With the scarce resources in the country, migrations emanating from climate change are a major threat to the well-being of all as one is either directly or indirectly affected. Sabbarwal (2017) has lamented on increasing temperatures in Turkana region with conflicts increasing as people compete over reducing pasture and water resources. The author claims that with the area drying up and with temperatures having gone up by approximately 2 °C between 1967 and 2012, raids and migrations have been common. With the rainy seasons becoming shorter and drier, women and girls who are charged with the duties of fetching water have no option but to trek long distances to get the diminishing resource. Water has to be extracted by digging dry wells and riverbeds. With the reduced pastures, animals have died or become famished.

Cuni-Sanchez et al. (2019) carried out a study in northern Kenya and noted a lot of climatic changes in Mt. Kulal, Mt. Nyiro, and Mt. Marsabit. Natural rivers had turned into seasonal rivers. Reliance on firewood and other non-timber products had been affected greatly by changing climate. The unreliability of rains that at times would come when not expected and in low quantities forced people to devise different coping mechanisms which include migrations.

Climate-induced migrations have complicated life for those affected and created problems to the government (Corburn et al. 2020). Corburn and others (2020) recent work have pointed to Kenya's urban slums to a haven for COVID-19 infections. Some demographic projections estimate that over half of citizens in Kenya's capital, Nairobi reside in the slums (UN-Habitat n.d.). This has made it hard to share resources like water and housing. Both the national government and the county government have to struggle in provision of public goods and services to the slum population that is increasing by the day. Security has become an issue while environmental health has become an eyesore with dirt in the congested settlements becoming a nuisance.

---

## Materials and Methods

This study employed use a qualitative cross-sectional survey design. Data were collected in 2018 from three counties using questionnaire with open-ended questions. The open-ended questions included: (1) if climate change was

affecting women's livelihood differently from that of men; (2) ways in which climate change-induced migration of women differed from those of men; (3) the initiatives the county government should undertake to help people cope with climate change; and finally, (4) the participants' perceptions of the measures nongovernmental agencies should undertake to assist communities cope with climate change.

## Study Setting

The research was conducted at three counties in Kenya which are Kiambu, Machakos, and Makueni counties. The Kiambu county is generally lies at a higher attitude, is generally cool with high amounts of rainfall, followed by Machakos, with Makueni being classified as arid and semiarid county. The Kiambu County is generally wet, and the average annual rainfall for the Kiambu is 1000 mm annually. Machakos County, on the other hand, receives average rainfall, with some parts of the county experiencing similar weather patterns as Kiambu County, and other parts being relatively dry. Makueni County is classified as an arid and semiarid region. The county receives low amount of annual rainfall of 600 mm. Makueni county experiences frequent and prolonged droughts triggering crop failures, and is among the list of counties in that receives relief food to mitigative starvation, malnutrition.

## Data Analysis and Presentation of Results

This study used content analysis (Hsieh and Shannon 2005) and inductive coding (Strauss and Corbin 1998). Content analysis is a "technique for making inferences by objectively and systematically identifying specified characteristics of messages" (Holsti 1969, p. 14). Content analysis allows a blend of both quantitative and qualitative data analysis attributes to be combined. That is, the researchers can identify count data and compute frequencies/percentages for further analysis. In addition, these quantitative measures can be supported with themes/categories. This method was adopted due to the short nature of responses that was generated from the survey open-ended questions. There were two coding cycles. The first cycle enabled the researchers to describe the data. In the second coding cycle, the codes identified in the first cycle were compared, organized, and categorized (Tracy 2013). To increase credibility of the coding procedure, two people were involved, one of the researchers and a colleague who is familiar with the subject matter. The two researchers did both coding cycles together and where there was a disagreement, they discussed until they reached an agreement. Where possible thick descriptions were identified to support the themes/categories identified. In this study, the unit of analysis was the respondent and each of the four question were analyzed separately to identify themes.

## Results and Discussions

### Climate Change Affects Women's Livelihood Differently from That of Men: Empirical Evidence from the Study

Twenty two percent of the respondents did not think climate affects women's livelihoods differently than men. However, 88% of the respondents felt climate affected women's livelihoods differently from men. Table 1 summarizes the different themes emerged from the analysis of qualitative responses to the question "in what ways

**Table 1** Ways in which climate change affected women livelihood differently from that of men

Themes	Subthemes	Explanation	No of mentions	%
<b>More strain</b>	Domestic chores	Women faced more strain as most of the household chores were assigned to them. For instance, collecting firewood and fetching water	4	6.45
	Child/family care	Women faced more strain from taking care of the young ones	5	8.06
	Farm labor	Women had more responsibilities in preparing the farm, cutting pasture for animals, and harvesting	6	9.68
<b>Low income</b>	Low yields and inadequate food supply	The farms yielded low yields, leading to inadequate food supply for the family and poor nutrition	8	12.90
	Women as bread earners	Women had to run small agro-related businesses/farming to supplement or basically provide for the family	10	16.13
<b>Time demands</b>	More time demands searching water and firewood	Women had to walk long distances searching for firewood and water	10	16.13
	More time demands searching food	Women had to walk long distances searching for food	3	4.83
<b>Effects of time and strain demands</b>	Poor health	Women were prone to sicknesses due to effects of harsh cold weather in the fields, and strain and experienced cold-related sicknesses such as colds, asthma, arthritis, among others	14	22.58
	Domestic conflicts	The strain and time pressures contributed to domestic conflicts between the women and their spouses	2	3.22
				100

Source: Authors' survey results, 2020

does climate change affect women's livelihoods differently from that of men." Four themes, namely, more strain, low income, time demands, and effects of time and strain demands. The theme "more strain" can be described as "exert extra effort in carrying out domestic and farm related chores." This theme was comprised of four themes described in Table 1, namely, domestic chores, child/family care, and farm labor. Women in the rural areas in many parts of the SSA, particularly in Kenya, bear disproportionate burden of household chores (Muasya and Martin 2016; Mokomane 2014). As men migrate to towns and cities to look for better income opportunities, this adds to the burden women bear as a consequence of climate change particularly prevalent and prolonged droughts. Majority of rural areas lack access to reliable and/or affordable water sources, and most households rely on surface water resources for household and domestic needs (Kelly et al. 2018). Most of these sources are seasonal rivers and water springs which run dry during dry spell, meaning women have to walk longer distances during drought seasons to look for the scarce commodity (Cherutich et al. 2015). As one of the participants A1 remarked:

women are more burdened as they have to source for their families' necessities

while participant B1 had the same concerns:

Women travel long distances searching for water for domestic use apart from caring for the family

Also, unlike urban areas where working class women hire house helps to assist with child care and other family chores (Muasya 2014), women in rural areas grapple with insufficient resources for survival, meaning they have to bear the burden of child and family care demands. Previous studies have shown that where husbands are present, they provide some support in these tasks reducing stress related to child/family care and work-balance conflicts (Muasya 2016). However, as men migrate to towns and cities, rural women have to bear the extra burden of attending to family chores while carrying children on their backs. As one participant B2 commented:

Women are more affected as they have to fetch water and take care of the young ones

It is estimated that rural women provide over 80% of farm labor in the rural areas at the SSA region (Ogunlela and Mukhtar 2009). Majority of the rural households lack resources for mechanization, meaning they rely on rudimentary tools and approaches to accomplish most of the farm activities, from digging, land preparation, planting, weeding, harvesting, and postharvest tasks (FAO 2011). As men and young people migrate to towns and cities to run-away from difficulties precipitated by climate change in rural areas, which means women have to bear the burden of accomplishing all these tasks on their own as participant A5 alluded:

Women are more into the farms harvesting crops and also its preparation

The theme “low income” implies that women earned low income due to declining yields. This theme comprised two subthemes, namely, low yields and inadequate food supply, and low income from agro-related businesses. Rural women rely on selling a variety of farm produce for financial sustenance, and also to provide support to diverse family needs, from purchasing food to educating their children, farm produce consists the main supply of food and nutrition to families. In a study of stressors and work family conflict among urban female teachers, Muasya (2020) found that low income was a stressor to teachers with low income which further made them seek extra sources of income exacerbating their work life balance challenges. In addition, severe and prolonged droughts associated with climate change have been prevalent in the study sites, particularly Makueni County in the last 5 years, resulting into massive crop failures and livestock deaths (Amwata et al. 2015). This led to massive starvation, malnutrition, especially where humanitarian interventions are rarely available (Amwata et al. 2015). This is worsened as most men migrating to towns and cities end up in low-income informal employment and lack extra income to sustain their rural families left behind in rural areas. As one participant C5 remarked:

Yes. Most of women depend on small scale farming which due to climate change do not produce enough

This was echoed by participant C8,

Low yields make women struggle very much to find food

The theme “time demands” implies “women spent more time in household chores, farming than men who migrate to towns for industrial jobs.” This theme comprised of two subthemes, namely, more time demands searching water and firewood, and more time demands searching food. Although for households living in urban areas, both men and women participate in paying water bills, energy bills, and purchasing food, on the contrast, in the rural areas in most parts of SSA region, women are the ones responsible for collecting water, firewood for cooking, looking for food and the cooking as well (Tian 2017). The burden of the multiple task of looking for food and the time expended walking long distances to look for water particularly during droughts, collecting firewood causes real strain and stress upon rural women (Tian Tian 2017). The quotes by two survey participants below highlight the predicament rural women face out of the experiences during extreme climate change events, particularly droughts. As participants A5, B3, and C4 remarked, respectively:

women spent a lot of time searching for clean water

Yes. Women waste a lot of time walking far distances looking for water unlike men

Women walk long distances searching for water hence wasting a lot of time

The last theme identified was on the effects of time and strain demands. The results of the survey identified two subthemes that had to do with how participants



perceived climate change events to affect women, namely, poor health and domestic conflicts. Many participants attributed the vulnerability of women to women's prolonged hours in the farms, or walking to collect water and/or firewood to increase the prevalence of illnesses such as colds, asthma, arthritis, among others. Given that women have to carry along their infants during most of these tasks, participants were concerned that their infants and children were by extension exposed to the negative health effects experienced by rural women due to climate change.

Besides poor health, women experienced domestic conflicts. Too much strain and time pressures led to strained marital relationships between the spouses. The women could not be in a position to be equally present at home to take care of children, prepare food in good time, or even offer conjugal rights to their spouses. Studies have shown women even in the formal sector with no adequate support for child care tend to quit their work (Muasya 2017). On the other hand, delegation of house chores and childcare chores can be a source of conflict as well, when these women fail to undertake these chores as socially expected. Moreover, as more household and farm tasks are carried out by women than their spouses, these women can perceive it that their spouses have neglected their duties and it can result to more domestic strife. Indeed, lack of work life balance and delegation of chores can be a source of domestic conflict (Muasya and Martin 2016).

### **Ways in Which Experiences of Climate Change-Induced Migration Differed for Men and Women**

Majority of participants (90%) felt that that climate change-induced migration differed for men and women. Specifically, more men than women left home and migrated from rural areas to urban areas to look for alternative sources of income, search for pasture, or work in farms. Consequently, women were left with more responsibilities. The quotes below highlight participants perceptions on the different ways in which experiences of climate-induced migration differed for men and women as participant A10 narrated:

men migrate to look for jobs while women engage in simple chores to cater to-day-today needs

and participant A12 remarked:

most men migrate in search of alternative sources of livelihood while women remain behind to cope with the change

And participant B6 said:

diverse climatic change makes most men travel to towns leaving families behind

## Measures by County Governments to Assist Communities Cope with Climate Change-Induced Migration

Table 2 summarizes the different themes emerged from the analysis of qualitative responses to the question “measures by county governments to assist communities cope with climate change induced migration.” Eight themes, namely, climate change

**Table 2** Measures by county governments to assist communities cope with climate change-induced migration

Themes	Subthemes	Explanation	No of mentions	%
Climate change mitigation/adaptation		Encourage reforestation, planting of trees, agroforestry, and reduce cutting of trees	7	6.31
Women empowerment		Women empowered to make financial decisions that can empower them	6	5.40
Strengthening water adaptive capacity	Increased water harvesting and storage	One way to curb drought is increased water harvesting storage through provision of water harvesting resources such as funds, materials, e.g., water tanks, involved in sinking boreholes, dam reservoirs	47	42.34
	Sensitization on water harvesting	Women farmers to be sensitized on the need of water harvesting and ways to harvest water	3	2.70
Soil and water conservation		The need to preserve soil and water through measures such as gabions, water friendly trees, curbing farming along rivers, etc.	8	7.21
Climate smart agriculture	Drought-resistant crops	Farmers to grow drought-resistant and fast-maturing crops with minimal irrigation	15	13.51
	Drought education	Sensitization and education on drought-tolerant crops and information on weather patterns, e.g., from meteorological department	8	7.21
Diversifying livelihoods		Women to be encouraged to explore other non-farm income-generating activities	6	5.40
Humanitarian assistance		The county and nongovernmental organizations to identify and support the most vulnerable groups to climate change such as orphans and the very poor	5	4.50
Individual and institutional capacity building		Enhancing the capacity of women and the local institutions on ways to harvest and conserve water	6	5.40
				100

Source: Authors' survey results, 2020

mitigation and adaptation through tree planting; women empowerment; strengthening households' water adaptative capacity; soil and water conservation (resilience capital); promoting climate smart agriculture; sharing meteorological information/data with rural households; promoting diversification of livelihoods; and targeted humanitarian assistance and strengthening individual and institutional capacity.

The theme on tree planting did not have many categories, and there was little variability of responses from sampled participants. Suggested items included "reforestation"; "sensitizing people to plant trees"; "educating residents on importance of planting trees"; "planting drives on water catchment"; "encouraging people to plant more trees"; "encourage people to avoid cutting down of trees"; and "encouraging tree nurseries." There are several ways in which these measures mentioned by participants can be linked to coping with climate change-induced migration. Planting trees becomes a source of income from the sales of animal fodder, firewood, fruits, thereby providing women with the need supplies to meet households and domestic needs. Some fruits planted in the study sites, particularly Machakos and Makueni Counties, include grafted mangoes that incidentally do well during seasons of crop failures, thereby acting as a buffer to household income and food supplies (Muema et al. 2018).

Women empowerment was another theme that emerged from the analysis of participants' responses regarding the open-ended question on what measures by county governments to assist communities to cope with climate change-induced migration. In most rural settings in the SSA region, patriarchal structures largely influenced decisions related to access to land for cultivation, farm inputs, harvest and postharvest, access to capital to support farm labor, access to capital for physical assets such as farm equipment, water harvesting, and improved cooking stoves (FAO 2011). Even where microfinance existed to support women's efforts, many women had to still seek consent from their spouses, even when the needs were pressing. Such patriarchal structures further limit or frustrates women's intention to build asset portfolio (social networks, human capital, natural capital, physical capital, and financial capital) necessary for climate resilience, and adaptation. The last decade or so has seen many countries including Kenya address women's marginalization particularly in relation to land inheritance, land ownership, and this has spillover benefits particularly reducing gendered vulnerabilities associated with climate change events such as droughts (FAO 2011).

The theme on strengthening households adaptative capacity has several sub-themes, namely, increasing supply of materials for water harvesting/funds; supplying water tanks; drilling boreholes; digging dams and reservoirs; and sensitization of communities on water harvesting. Women and children, especially in the rural areas, suffer most problems associated with inaccessibility to reliable and affordable safe sources of water for household and domestic use (Graham et al. 2016). Consequently, improving water accessibility greatly improves the capacity of rural households to cope with climate induced migration, particularly when they are faced with limited human capital because men/husbands have migrated to towns and cities. Also, in pastoral communities, climate change-induced conflicts over diminishing water sources and pasture are quite common in the SSA (Witsenburg and Adano

2009). Consequently, measures such as digging boreholes, water harvesting structures such as dams help communities to better cope with induced migration as they have access to more options in terms of water sources to support their livestock (Witsenburg and Adano 2009).

Soil and water conservation was another theme that was identified, and three subthemes, namely, gabions, water friendly trees on catchment areas, and avoiding farming near rivers. Soil erosion and bad land use practices such cultivating along rivers backs undermine the resilience capital rural dwellers desperately require coping with climate change-induced migration.

Climate smart agriculture is further identified to be another theme that emerged in the analysis of qualitative responses related to county government measures to assist communities to cope with climate-induced migration. Three subthemes identified here included: drought-resistant or fast-maturing crops/seeds; irrigation; and sensitization and education of drought-tolerant crops. Other themes identified included: sharing meteorological information/data with rural households; diversifying livelihoods; timely and strategic humanitarian assistance; and strengthening rural institutions.

### **Measures by Nongovernmental Agencies to Assist Communities Cope with Climate Change-Induced Migration**

Six themes emerged from the qualitative analysis of participants' responses in relation to measure nongovernmental agencies have taken to assist communities cope with climate change-induced migration. Four of the themes seemed to overlap with measures undertaken by county governments. However, two of these themes differed significantly from the measures participants suggested in relation to the role of the county government, namely, climate change advocacy and diverse range of humanitarian interventions. Statements implying climate change advocacy were most frequently mentioned measures by respondents.

The range of humanitarian interventions that NGOs were involved with to assist communities cope with climate change and consequences of climate-induced migration included: supporting children from very poor families; providing food to poor families; providing medical care, providing mobile clinics for health; child sponsorship; providing cheaper energy options for cooking; and providing seeds for planting (Table 3).

---

### **Lessons Learned, Study Limitations, and Recommendations for Future Research**

Rural households in the study sites observed that climate change affects women's livelihoods differently from men. Specifically, climate change exerts more strain on women, lowers their agro-dependent income due to crop failures and reduced yields, increases time demands women have to spend on household chores such as looking

**Table 3** Measures by nongovernmental agencies to assist communities cope with climate change-induced migration

Themes	Subthemes	Explanation	No of mentions	%
Adaptation through water harvesting	Providing water harvesting resources	This water harvesting can be achieved through provision of water harvesting resources and assistance in sinking boreholes and dams	7	8.33
	Water harvesting education and sensitization	Provide water harvesting education and sensitization to communities	2	2.38
Climate change advocacy		Engage the communities and government on policy change to change to new ways of farming technologies	21	25%
Support livelihood diversification			10	11.90
Support climate mitigation measures			13	15.48
Climate smart agriculture			16	19.05
Humanitarian intervention			15	17.86
				100

Source: Authors' survey results, 2020

for water as local water sources dry up, looking for firewood, and the effects of time and strain demands, and have negative impacts on women's, infants, and children's health. Rural communities felt that climate change-induced migration differed for men and women; specifically, more men than women left home and migrated from rural areas to urban areas to look for alternative sources of income, search for pasture, or work in farms. Consequently, women were left with more responsibilities. Regional/county governments' measures to assist communities cope with climate change-induced migration include: supporting climate change mitigation and adaptation through increased tree planting; women empowerment; strengthening households' water adaptative capacity; soil and water conservation (resilience capital); promoting climate smart agriculture; sharing meteorological information/data with rural households; promoting diversification of livelihoods; targeted humanitarian assistance; and strengthening individual and institutional capacity. While nongovernmental agencies also participate in most of these measures, they seem to bring in strength in relation to climate change advocacy and a very diverse range of humanitarian interventions.

The study sample was limited the three counties in Kenya, and findings may not be generalizable in other parts of the SSA. The rural livelihoods communities studied are more-or-less sedentary, and future studies may need to focus on pastoral/nomadic communities. Also, the study investigated gendered vulnerabilities to climate change

impacts and climate-induced migration largely among rural communities' settings. Future research will need to expand this work to urban settings and coastal communities.

The research design followed was cross-sectional survey, future studies are needed to include large sample, and probably use longitudinal designs to observe gendered vulnerabilities and climate-induced migration over a relatively longer study period.

In this study, trained research assistant participants filled responses to the open-ended questions according to participants answers. This limited the ability to capture participants emotions that can add perspective to the qualitative data collected. Future cross-sectional surveys would need to record participants narration, transcribe verbatim, the responses then analyze data.

---

## Conclusion

Indeed, we can conclude that climate change does have negative effects on the livelihoods of rural women in a more disproportionate way compared to men. Thus, intervention whether through the county government or nongovernmental organizations may be required to factor in gender and socioeconomic factors in their policies and intervention programs. Failure to mitigate the negative effects of climate change in rural settings might worsen the livelihoods of women and children, undermining progress the sustainable development of reducing gender inequality, and also health for all citizens.

---

## References

- Amwata DA, Nyariki DM, Musimba NR (2015) Factors influencing pastoral and agro-pastoral household vulnerability to food insecurity in the drylands of Kenya: a case study of Kajiado and Makueni counties. *J Int Dev* 28(5):771–787
- Barrios S, Bertinelli L, Strobl E (2006) Climatic change and rural-urban migration: the case of sub-Saharan Africa. *J Urban Econ* 60:357–371
- Cherutich J, Maitheo T, Omware Q (2015) Water access and sustainable rural livelihoods: a case of Elementaita division in Nakuru county, Kenya. *Int J Sci Technol Soc* 3(1):9–23
- Chindarkar N (2012) Gender and climate change-induced migration: proposing a framework for analysis. *Environ Res Lett* 7(2):025601
- Corburn J, Vlahov D, Mberu B et al (2020) Slum health: arresting COVID-19 and improving well-being in urban informal settlements. Yale School of Medicine. <https://medicine.yale.edu/news-article/23734/>. Accessed 5 July 2020
- Cuni-Sanchez A, Omeny P, Pfeifer M, Olaka L, Mamo MB, Marchant R, Burgess ND (2019) Climate change and pastoralists: perceptions and adaptation in montane Kenya. *Clim Dev* 11(6): 513–524
- FAO (2011) The State of Food and Agriculture 2010–11 | FAO | Food and Agriculture Organization of the United Nations. Available at: <http://www.fao.org/publications/sofa/2010-11/en/>. Accessed 25 June 2020
- Graham JP, Hirai M, Kim SS (2016) An analysis of water collection labor among women and children in 24 sub-Saharan African countries. *PLoS One* 11:e0155981

- Hassan OM, Tularam GA (2018) The effects of climate change on rural-urban migration in sub-Saharan Africa (SSA) – the cases of democratic Republic of Congo, Kenya and Niger. In: Applications in water systems management and modeling, vol 10. IntechOpen, London, pp 64–68
- Holsti OR (1969) Content analysis for the social sciences and humanities. Addison-Wesley, Reading
- Hsieh HF, Shannon SE (2005) Three approaches to qualitative content analysis. *Qual Health Res* 15 (9):1277–1288
- Easterling WE III, Hurd BH, Smith JB (2004) Coping with global climate change: the role of adaptation in the United States. Pew Center on Global Climate Change, Arlington
- Tollefson, J. IPCC says limiting global warming to 1.5 C will require drastic action. *Nature* 2018, 562, 172–173.
- Kalungu JW, Leal Filho W, Harris D (2013) Smallholder farmers' perception of the impacts of climate change and variability on rain-fed agricultural practices in semi-arid and sub-humid regions of Kenya. *J Environ Earth Sci* 3:129–140
- Kartiki K (2011) Climate change and migration: a case study from rural Bangladesh. *Gend Dev* 19 (1):23–38
- Kelly E, Shields KF, Cronk R, Lee K, Behnke N, Klug T, Bartram J (2018) Seasonality, water use and community management of water systems in rural settings: qualitative evidence from Ghana, Kenya, and Zambia. *Sci Total Environ* 628–629:715–721
- Kolmannskog V 2009 Climate change, disaster, displacement and migration: initial evidence from Africa New Issues in Refugee Research No. 180 (United Nations High Commissioner for Refugees)
- Mokomane Z (ed) (2014) Work–family interface in sub-Saharan Africa: challenges and responses. Springer, Cham
- Muasya G (2014) The role of house helps in work–family balance of women employed in the formal sector in Kenya. In: Work–family interface in sub-Saharan Africa. Springer, Cham, pp 149–159
- Muasya G (2016) Work-family balance and immigrant sub-Saharan women in the United States. In: Communication and the work-life balancing act: intersections across identities, genders, and cultures. Lexington Books, London, pp 163–184
- Muasya G (2017) Work-family conflict, support and intention to quit among Kenyan female teachers in urban public schools. *S Afr J Labour Relat* 41(1):33–45
- Muasya, G. (2020). Stressors and work-family conflict among female teachers in urban public schools in Kenya. *South African Journal of Education*, 40(2).
- Muasya G, Martin JN (2016) Conflict in Kenyan households: an exploratory study of professional women and domestic workers. *Howard J Commun* 27(4):385–402
- Muema E, Mburu J, Coulibaly J, Mutune J (2018) Determinants of access and utilisation of seasonal climate information services among smallholder farmers in Makueni County, Kenya. *Heliyon* 4 (11):e00889
- Ngugi L, Rao K, Oyoo A, Kwena K (2015) Opportunities for coping with climate change and variability through adoption of soil and water conservation technologies in semi-arid Eastern Kenya. In: Adapting African agriculture to climate change. Springer, Cham
- Ogunlela YI, Mukhtar AA (2009) Gender issues in agriculture and rural development in Nigeria: the role of women. *Humanit Soc Sci J* 4(1):19–30
- Rahman MS (2013) Climate change, disaster and gender vulnerability: a study on two divisions of Bangladesh. *Am J Hum Ecol* 2(2):72–82
- Ravera F, Martín-López B, Pascual U, Drucker A (2016) The diversity of gendered adaptation strategies to climate change of Indian farmers: a feminist intersectional approach. *Ambio* 45 (Suppl 3):335–351
- Sabbarwal S (2017) Indigenous peoples' concerns for environment: examining the role of non-governmental organizations. *Fourth World J* 15(2):27–39
- Serdeczny O, Adams S, Baarsch F et al (2017) Climate change impacts in sub-Saharan Africa: from physical changes to their social repercussions. *Reg Environ Chang* 17:1585–1600
- Sheikh AA (2017) Effects of climate variability on human migration dynamics: a case study of Ifo refugee camp, Daadab complex – Kenya, p 110

- Strauss A, Corbin JM (1998) Basics of qualitative research techniques and procedures for developing grounded theory. Sage, Thousand Oaks
- Tian X (2017) Ethnobotanical knowledge acquisition during daily chores: the firewood collection of pastoral Maasai girls in Southern Kenya. *J Ethnobiol Ethnomed* 13:2
- Tracy SJ (2013) Qualitative research methods. Wiley-Blackwell, Chichester
- UN-Habitat (n.d.) Kenya Habitat Country Program Document: 2018–2021 enhancing effective service delivery and sustainable urban development at national and county levels. UNHabitat, Nairobi
- United Nations (2016) General adopts declaration for refugees and migrants as United Nations Organization sign key agreement. Retrieved from <https://www.un.org/press/en/2016/ga11820.doc.htm>
- United Nations Framework Convention on Climate Change handbook (2006) UNFCCC handbook. UNFCCC Climate Change Secretariat, Bonn
- van der Land V, Hummel D (2013) Vulnerability and the role of education in environmentally induced migration in Mali and Senegal. *Ecol Soc* 18(4):14
- Waldinger, M., & Fankhauser, S. (2015). Climate change and migration in developing countries: evidence and implications for PRISE countries.
- Witsenburg KM, Adano WR (2009) Of rain and raids: violent livestock raiding in Northern Kenya. *Civ Wars* 11(4):514–538

**Open Access** This chapter is licensed under the terms of the Creative Commons Attribution 4.0 International License (<http://creativecommons.org/licenses/by/4.0/>), which permits use, sharing, adaptation, distribution and reproduction in any medium or format, as long as you give appropriate credit to the original author(s) and the source, provide a link to the Creative Commons license and indicate if changes were made.

The images or other third party material in this chapter are included in the chapter's Creative Commons license, unless indicated otherwise in a credit line to the material. If material is not included in the chapter's Creative Commons license and your intended use is not permitted by statutory regulation or exceeds the permitted use, you will need to obtain permission directly from the copyright holder.







# Unlocking Climate Finance Potential for Climate Adaptation: Case of Climate Smart Agricultural Financing in Sub Saharan Africa

# 101

Edward M. Mungai, S. Wagura Ndiritu, and Izael da Silva

## Contents

Introduction .....	2064
The Concept of Climate-Smart Agriculture .....	2067
The Potential for Climate-Smart Agriculture in Sub-Saharan Africa .....	2067
Climate-Smart Agriculture Opportunities and Impeding Challenges in Sub-Saharan Africa .....	2069
Countries Selection .....	2070
Sampling Selection Method .....	2071
Situational Analysis of Priority Countries .....	2071
Estimating Climate Investment Potential .....	2071
CSA Financial Potential and Barriers Associated with CSA Financing .....	2073
Financing Potential for Climate-Smart Agriculture in Sub-Saharan Africa .....	2073
Barriers Hindering the Private Sector from Investing in CSA in Africa .....	2075
Conclusion .....	2079
References .....	2080

This chapter was previously published non-open access with exclusive rights reserved by the Publisher. It has been changed retrospectively to open access under a CC BY 4.0 license and the copyright holder is “The Author(s)”. For further details, please see the license information at the end of the chapter.

E. M. Mungai · S. W. Ndiritu  
Strathmore University Business School, Nairobi, Kenya  
e-mail: [emungai@kenyacic.org](mailto:emungai@kenyacic.org); [sndiritu@strathmore.edu](mailto:sndiritu@strathmore.edu)

I. da Silva (✉)  
Strathmore University, Nairobi, Kenya  
e-mail: [idasilva@strathmore.edu](mailto:idasilva@strathmore.edu)

---

**Abstract**

Climate change has emerged as one of the greatest challenges faced by the world today. Adverse impacts of climate change are visible across sectors like agriculture and other natural resources due to increasing average temperature and changing weather patterns. Africa constitutes around 13% of the global population but contributes the least (around 2%) to greenhouse gas (GHG) emissions globally. Concerning the global climate vulnerability index, Africa is most impacted (around 21%) by climate change and its' population is most vulnerable to climate sensitivity and fragility of the continent's natural environment and increasingly erratic weather patterns, low adoption of climate-resilient technologies, and high dependence on environment-based livelihoods. Hence, Africa needs to adopt low carbon and climate-resilient development to address climate-related issues and to have sustainable development. In line with the low carbon/climate-resilient development agenda, 53 countries (except Libya) have submitted Nationally Determined Contribution (NDC) and have set ambitious targets under NDC and Sustainable Development Goals. A quick analysis of the NDCs and various studies indicates the enormity of the financing needs. According to Climate Investment Funds (CIF), Sub-Saharan Africa will require an estimated USD222 billion for climate resilience investments to reach its NDCs. One of the critical stakeholders to play a key role in meeting the financing needs of climate-smart agriculture (CSA) related targets is the private sector. There is around 98% gap in financing for CSA. Even though substantial climate finance potential exists in selected countries for the private sector, there are certain challenges and barriers like financial, policy, lack of awareness, and low provision for climate funding in the national budget.

---

**Keywords**

Climate-smart agriculture · Unlocking climate finance · Sub-Saharan Africa · Climate adaptation · Private sector

---

**Introduction**

An additional 2.4 billion people – representing a one-third increase in the global population – will occur between 2013 and 2050 (FAO 2013). Further, the Food and Agriculture Organization (FAO) approximates the additional population will translate into a 60% increase in demand for agricultural production. Undoubtedly, agriculture is well-positioned to be a reliable basis for economic growth and poverty reduction. Conversely, the ongoing global environmental concern of climate change has adverse impacts on agriculture that is also a contributing factor to the drastically changing weather and climatic patterns. Consequently, for agriculture to satisfactorily feed the growing population, the current agriculture practices need to spiral into more adaptive hence sustainable practices. A breakthrough hinged on climate-smart

agriculture (CSA) approach that encompasses three perspectives: increasing productivity in a sustainable manner, enhancing adaptation/resilience, and mitigating the emission of greenhouse gases (GHGs) as emerged as a way to realize food security and achieve the developmental goals. Notably, 56% of Africa's population will reside in urban areas by 2025 and half of the projected population growth will be in Sub-Saharan Africa (UNDESA 2019 and 2014). This entails that agriculture, specifically in Africa, has to undergo a major transformation to fulfill the intertwined challenges of achieving food security, reducing poverty, and responding to climate change without depletion of the natural resource base. Despite the common consensus on the potential for climate-smart agriculture in Africa, there is a conspicuous paucity in wholesome quantifiable empirical evidence. To fill this gap, this chapter looks into the potential for climate-smart agriculture in 14 select countries in Sub-Saharan Africa (SSA) representing East, West, Central, and Southern Africa.

World Bank (2015) estimates that about 48% (approximately 450 million people) of Africa's population live in extreme poverty, i.e., less than US \$1.25 in a day. Also, 63% of Africa's population lives in rural areas, wholly dependent on agriculture as a source of living (World Bank 2015). More than 60% of the African population works in the agricultural sector that accounts for about 25–34% of the continent's gross domestic production (GDP). Conceivably, agriculture looms large in the African economy. Unfortunately, a collective report by FAO, IFAD, and WFP (2014) revealed that agricultural production is low leading to high food insecurity. A reason attributed to sluggish income growth, high poverty rates, and dilapidated infrastructure in the rural areas that impair market access. A situation further exacerbated by weak policies, civil unrest, periodical disease outbreaks, overlapping rules, poor coordination, and inept collaboration among institutions within the climate-smart agriculture realm. One in four people remains malnourished in Africa with a high prevalence of stunted and underweight children due to poor dietary quality and diversity, mostly among the poor. Increasing agriculture's adaptive capacity will be necessary to prevent a slide back into poverty and hunger.

Growth in agriculture is the most viable and equitable strategy to spur economic growth in Africa by reducing poverty and enhancing food security in Africa. However, it has to overcome the climate change-related challenges. For instance, Barkhordarian et al. (2012), Radhouane (2013), and IPCC (2014) postulated that the annual rainfall in Sub-Saharan Africa will possibly decrease by about 4–47% resulting in droughts and increased salinity. It resonates with Intergovernmental Panel for Climate Change observations that crop and fodder growing periods in both western and southern Africa will likely shorten by an average of 20% by the year 2050. Resultantly, there will be a 40% decline in cereal yield and an additional reduction in cereal biomass for livestock (Lobell et al. 2011). According to Hoerling et al. (2006) western, central, and southern Africa will record a decline in the mean annual rainfall of 4%, 5%, and 5%, respectively. In the rest of Africa, drought conditions will not only be more frequent and intense but also more long-lasting leading to an increase in the arid and semiarid area approximately to about 5–8% by 2080 (Elrafy 2009). As a factor attributed to the sensitivity of the current farming systems to drought, the cumulative crop yield decline across the continent is

forecasted at 50% by 2020. Thornton et al. (2008) contend that the net revenues from crops may likely fall by about 90% by 2100. Further, both agropastoral, pastoral, and mixed-crop livestock systems will potentially be affected by a constraint of animal feed and water in addition to advancing pest severity and disease distribution (Thornton et al. 2008). Against such a grim picture, there lies an excellent opportunity with CSA for transformation by collating agriculture, economic growth, and climate change under the umbrella of sustainable development. Four agroecological zones in SSA serves as case studies for underlying CSA investment potential.

To facilitate CSA adoption in developing countries, respective governments' have claimed their right to public grants with lesser regard to private financing (Pauw 2014). The latter predisposition of the developing countries is in line with the United Nations Framework Convention on Climate change (UFCC) principle of "the polluter pays." The approach implies that developed countries should play a greater role in providing climate adaptation finance for being major contributors of climate change. Bindingly, developed countries pledged US \$100 billion every year from 2020 onwards (UFCC 2011). A target that Pauw et al. (2015) doubts if it will be met, actually UNEP FI (2009) postulates that public funding cannot sufficiently finance climate change adaptation costs. Pauw (2014) proposes that the private sector can supplement but not substitute public investment in climate finance. Observations by UFCC (2007) approximated the global private sector investment and financial flows at 86%. Further, SER (2011) cite that 90% of the population in emerging economies depends on the private sector as a source of income. Pauw and Pegels (2013) argues that the private sector can play a potentially significant role in adaptation engagement. As a result of the private sector potential, it was included as one of the finance sources. However, as put forward by Surminski (2013), the evidence base – reasonable activity, predictable returns and acceptable risk for private sector investment – is limited (Christiansen et al. 2012).

This chapter will contribute to the extant literature in twofolds. First is a pioneering academic exploration into quantifying the investment potential and the funding gap in climate-smart agriculture in Africa. This is unlike recent work of Tran et al. (2019) that focused on determinants for the adoption of CSA technologies in developing countries and Pauw and Pegels (2013) with a reflection on the role of the private sector in developing countries. This chapter also digresses from a study by Zougmore et al. (2018) and Nciizah and Wakindiki (2015) that looked into the prospects and the achievements of CSA in Africa. Secondly, unlike past generalizations on the areas that need climate financing, this chapter will identify the financial, regulatory, and policy barriers hindering private sector investment into CSA projects in Sub-Saharan Africa. In general, this work will add to the ongoing research on the conceptual clarity of private sector engagement in climate adaptation in developing countries (Pauw and Pegels 2013; Pauw 2014).

Based on the selected sample, this work found out that the highest climate-smart agriculture finance potential (in USD billion) lay with Ethiopia at USD 26 billion, distantly followed by Nigeria at USD 17 billion, and further down is Kenya at USD 9 billion which is almost the same case for Madagascar at USD 8 billion. Interestingly, CSA was termed as more investor-friendly, receiving a cumulative investment of

USD 79 billion in the 14 countries. Notwithstanding the CSA potential, the sector faces several challenges including inadequate financing, weak policies, and knowledge gaps within the key institutions. Nonetheless, there is a 98% untapped climate-smart agriculture investment potential that the private sector can exploit through climate financing.

The remainder of this chapter proceeds as follows. The second section will provide an elaborate literature review while the following section will look into the methodology that was used to come up with the conclusions and recommendation. Finally, the chapter will conclude by presenting the conclusion and recommendations.

---

## **The Concept of Climate-Smart Agriculture**

The approach to developing the technical capacity, accommodative policies and create an enabling environment for investment towards sustainable agriculture in the face of climate change was put forward by FAO (2013). CSA simultaneously addresses the global concerns of food security, ecosystem management, and climate change, therefore incorporating the three dimensions of sustainable development: economic, social, and environmental conditions. Nciizah and Wakindiki (2015) identifies three pillars of CSA as: (1) sustainably increasing agricultural productivity from crops, livestock, and fisheries without detrimental effects to the ecosystem, (2) reducing short-term farming shocks while enhancing their resilience by increasing farmers adaptability to long-term stresses, and (3) mitigating (GHG) emissions by either removing or reducing possible pollution instances. At the grassroots, CSA is intended to bolden the livelihoods through food security mostly among the small-scale farmers. This is by improving the management of natural resources and shifting to suitable technological approaches for the production, processing, and marketing farm produce. Relatedly, at the national level, CSA is tailored to prompt mainstreaming of policy, technical, and financial mechanisms that facilitate a base for operationalization of climate change adaptation within the agriculture sector. There is a vast array of CSA technologies that can be used singly or in combination in response to various environmental conditions (Teklewold et al. 2017). But mainly, the adoption of CSA technologies among farmers differs based on cultures, preferences, awareness, socioeconomic backgrounds, and resource availability (Maguza-Tembo et al. 2017). However, successful CSA requires an appropriate match between agricultural production technologies with social, economic, and environmental conditions.

## **The Potential for Climate-Smart Agriculture in Sub-Saharan Africa**

In West Africa, there is a high and fast-growing population and increasing agricultural production intensification to meet the growing food demand is very limited. Buah et al. (2017), Jalloh et al. (2012), and Sanou et al. (2016) postulate that to enhance food security in West Africa there will be a need to have animals that have resilient genetic potential, drought-resistant crop varieties that are also hardly

affected by insects and diseases. Besides, the management of soil carbon and fertility techniques will be handy for the region. Jalloh et al. (2012) also note that increasing capabilities among the smallholders and large-scale irrigated farms are likely to open up new opportunities for CSA through approaches such as crop-livestock interactions. CSA opportunities in Central Africa lie from an increasing but also a food-insecure population. In this case, sustainably increasing agricultural productivity will not only enhance food security but will also prevent deforestation. CSA aims at limiting the expansion of cultivated land into forests by seeking alternatives in better agricultural techniques that are productive hence restoring lost ecosystems.

Torquebiau (2015) contends that to enhance food security in East Africa, CSA practices need to put more emphasis on increasing livestock productivity, soil conservation, and management of water and natural resources at both landscape and small-scale levels, adaptive intensification of the cropping systems. Further, Partey et al. (2016) and Zougmore et al. (2015) observed that CSA innovations in East Africa should expound into agroforestry, development of stress-tolerant crops and livestock, crop-livestock diversification, as well as combining conservation agriculture with integrated soil fertility management. For instance, research by Wambugu et al. (2011) in Western Kenya found out that short-term agroforestry fallows being used in some parts of Western Kenya increased the annual net income of farmers to between US \$62 and 122. Such interventions need to be adopted across Africa although with regional-suited species.

According to Mapfumo et al. (2015), South Africa rainfall is expected to decrease and incidences of drought to increase just like other parts of Africa. Similarly, like East Africa, South Africa has to increase its agricultural productivity through intensification. The most crucial CSA approaches in South Africa will be integrated soil, water, nutrient, and organic manure management (Mapfumo et al. 2015). Additionally, soil carbon, salinity, and organic matter regulation will be critical gains for CSA in empowering the smallholder communities to overcome the food shortages and nutrient scarcity. Mbow et al. (2014) also advocated for the use of legume cereal rotational systems in South Africa that should be combined with inorganic fertilizers.

Majority of the Intended Nationally Determined Contributions (INDCs) have referenced agriculture as an adaptation priority, despite that in most cases, there are no cost estimates and adequate financial mechanisms (World Bank 2016). Of critical value in realizing the adaptation objectives is increasing the working and investment capital in climate-smart agriculture. In 2014, the total climate finance mobilized globally was US \$391, and despite agriculture's vulnerability to climate change, only US \$6–8 billion was committed to livestock, fisheries, and crops. Ironically, the total financing demand for smallholder farmers in Latin America, Asia, and Sub-Saharan Africa was estimated at \$210 billion. Consequently, agriculture in developing countries has a challenge of access to sufficient and adequate finance due to high and perceived risks, low margins for financiers, and profitability. As a result, financiers limit their exposure, raise the interest rates, tighten the lending requirements, shorten lending durations, and others opt for other economic sectors with stable returns (World Bank 2016). Among the factors contributing to

the funding gap are imbalanced risk-reward profiles, limited capacity to identify financial needs for adaptation, and insufficient evidence bases to identify suitable climate-smart practices and potential. Therefore, there is need to hypothesize that *there is a substantial climate-smart agriculture investment potential in African countries.*

### **Climate-Smart Agriculture Opportunities and Impeding Challenges in Sub-Saharan Africa**

In June 2014, leaders from African Union member states endorsed the adoption of CSA in the New Partnership for Africa's Development (NEPAD). Further, the summit crafted the African Climate-Smart Agriculture Alliance whose aim was to partner with regional economic communities and nongovernmental organizations in enhancing NEPAD planning and coordination to impact on 25 million farm households by the year 2025. Progressively, ECOWAS (2015) and Zougmore et al. (2015) note that Economic Community of West African States (ECOWAS) initiated the West Africa CSA Alliance to imbed climate-smart agriculture within the programs of ECOWAS Agricultural Policy (ECOWAP)/Comprehensive Africa Agricultural Development Program (CAADP). Respective heads of states that are signatory to NEPAD agreed to a collaboration between NEPAD Planning and Coordinating Agency (NPCA) and the nongovernmental organizations aimed at boosting agricultural productivity by boldening climate change adaptive capacity at the grassroots level. According to the African Union, the ensuing partnership was to avail technical aid to AU members to enhance CSA implementation. Similarly, the African Development Bank (ADB) together with partners were to support African countries on investing in CSA. Using FAO guidelines, several African countries have identified specific agriculture investment needs for the upscaling of CSA implementation (FAO 2012). More so, they have revised their National Agriculture Investment Plans.

On the analysis of the National Adaptation Plans of Action (NAPA) among the 47 least developed countries, about half (22) of the countries explicitly recognized the needed role from private sector (Pauw and Pegels 2013). According to the study, some of the countries broadly identified areas of engagement for the private sector. The countries view the private sector as a partner in the adaptation of sustainable sources of energy – specifically transition from wood and charcoal into solar and wind, agricultural practices, and water management. However, only one country (Mali) recognized the cofinancing role of the private sector (Pauw and Pegels 2013), showing low levels of awareness of the role of the private sector in climate adaptation. Alternatively, the failure to recognize the private sector in the NPAs may be intentional delusion to facilitate the scaling up of public funding. Altogether, 90% of the NPA recognized inadequate finance resources as a potential barrier to climate adaptation, and at the same time, only about 10% presented lack of private sector engagement as a barrier (Pauw and Pegels 2013).

Reportedly, national organizations have rapidly embraced CSA implementation. However, CSA is at its infancy due to a myriad of problems. Specifically, Barnard et al. (2015) present limited access to credit and finance as a major obstacle towards the adoption of CSA practices as they hinder access to farm tools and inputs. Further, Milder et al. (2011) argue initial investment into CSA is prohibitive especially for small farmers that according to Branca et al. (2012) constitute the largest share of agriculture investment in Africa. Mhlanga et al. (2010) reported that investment in agriculture by banks in Africa is barely 10% and attracts relatively high-interest rates. However, to unlock such potential, there is a need to carefully detail the barriers that may hold back CSA development in Africa.

Partey et al. (2016) noted that there is a limited understanding of the CSA concept and framework. All across Africa, farming practices and systems differ creating uncertainties into what technologies or activities constitute CSA. As the advocacy for CSA grows, essential stakeholders such as financial institutions fail to recognize their role in influencing the smart agriculture initiative hence failing to promote the scaling up investment. Williams et al. (2015) note that initially, there were policies, strategies, plans, and programs that were formulated without being informed by the concept of CSA. This has resulted in incompatibility challenges and at times leads to policy duplication. As an observation by Williams et al. (2015), the majority of the West African countries are yet to integrate climate change adaptation into their respective country's national agriculture programs. Additionally, there is limited investment in CSA due to a narrow number of technological packages and financial products (Partey et al. 2016). A factor that can be attributed to limited economic documentation of CSA implications that lead to a failed business case to attract investment (Sylla et al. 2012; Giller et al. 2009). Pauw and Pegels (2013) noted that attracting adaptation investment from the private sector may be challenging in developing countries due to constrained business environment, underdeveloped private sectors and lack of experience with adaptation engagement among the private sector. To help in the risk analysis necessary for private investment decision-making, there is need to hypothesize that there are *major challenges that hinder private sector investment in climate-smart agriculture in Africa*.

---

## Countries Selection

This section describes the process of determining the country of focus for the assessment of the CSA financial potential as well as the barriers to CSA financing in Sub-Saharan Africa. The work carried out was conducted in 14 countries: 4 from East, West, and Southern Africa and an additional 2 countries from Central Africa. The countries are about 30% representative of the four different agroecological regions in Africa. Table 1, depicts the number of countries in each region and the number of those shortlisted.



**Table 1** Number of shortlisted countries from each geographical region in Africa

S. No.	Sub-Saharan African region	Total number of countries	Number of countries shortlisted for climate finance study
1	Central Africa	7	2
2	East Africa	13	4
3	Southern Africa	14	4
4	West Africa	15	4

## Sampling Selection Method

The shortlisted countries were based on five key indicators related to climate change. First, as the study relates to unlocking private capital, the *foreign direct investment* (FDI) inflows into each country was factored in. Secondly, a consideration was given to the *climate risk score* to enable the inclusion of the most vulnerable countries in detailed research. Thirdly, desktop research was undertaken to identify the *climate finance requirements* for each of the countries. Fourthly, it was a consideration of the *ease of doing business* to provide key insight into government initiatives. Lastly, the *GDP and its growth curve* were put into consideration to determine the demand for each country. In each indicator, countries were ranked from the highest to the lowest as shown in Table 2.

The data for each indicator was collected from credible sources such as the World Bank and the International Finance Corporation. The data on climate risk score was retrieved from the Global Climate Risk Index score released by Germanwatch. Nationally Determined Contributions that were submitted by each country as per the Paris Agreement were reviewed to determine the climate finance requirement. Data from the Germanwatch that monitors the impacts of weather-related loss events were used to develop the country ranks for climate risk index. Climate Risk Index data for 2017 was used as it was the most recent.

## Situational Analysis of Priority Countries

After the indicator-based ranking, comprehensive desk research was carried out on climate vulnerabilities, climate change scenarios, national priorities, and policies related to climate change adaptation. Subsequently, a review of Nationally Determined Contributions and Sustainable Development Goals (SDGs) of the selected countries was conducted to identify climate adaptation investment potential.

## Estimating Climate Investment Potential

To estimate the investment potential for climate-smart agriculture up to 2030, there was detailed desk research of documents like the National Adaptation Plan Actions, Climate-Smart Agriculture – country factsheets, Economic Cost of Adaptation,

**Table 2** Ranking of countries based on the key indicators

Region/ parameter	GDP (current USD Billion)	FDI inflow (USD Million)	Climate risk score	Climate finance requirement	Ease of doing business	GDP growth rate (%)
<b>East Africa</b>	1. Sudan 2. Ethiopia 3. Kenya 4. Tanzania	1. Ethiopia 2. Tanzania 3. Sudan 4. Uganda	1. Somalia 2. Kenya 3. Ethiopia 4. Sudan	1. Ethiopia 2. Tanzania 3. Kenya 4. Rwanda	1. Rwanda 2. Kenya 3. Seychelles 4. Uganda	1. Ethiopia 2. Tanzania 3. Rwanda 4. Seychelles
<b>West Africa</b>	1. Nigeria 2. Ghana 3. Cote d'Ivoire 4. Senegal 5. Mali	1. Sierra Leone Nigeria 2. Ghana 3. Cote d'Ivoire 4. Guinea	1. Sierra Leone 2. Niger 3. Nigeria 4. Cote d'Ivoire 5. Ghana	1. Nigeria 2. Mali 3. Ghana 4. Senegal 5. Cote d'Ivoire	1. Ghana 2. Cape Verde 3. Mali	1. Guinea 2. Ghana 3. Cote d'Ivoire 4. Senegal Burkina Faso
<b>Central Africa</b>	1. DR Congo 2. Cameroon 3. Gabon	1. Gabon 2. DR Congo	1. DR Congo 2. Cameroon	1. DR Congo 2. Chad	1. Gabon 2. Cameroon 3. DR Congo	1. Central African Republic 2. DR Congo 3. Cameroon
<b>Southern Africa</b>	1. South Africa 2. Angola 3. Zambia 4. Zimbabwe	1. Mozambique 2. South Africa 3. Zambia 4. Namibia	1. Madagascar 2. South Africa 3. Mozambique 4. Malawi	1. South Africa 2. Zambia 3. Madagascar 4. Namibia	1. Mauritius 2. Botswana 3. South Africa 4. Zambia	1. Zimbabwe 2. Madagascar 3. Malawi 4. Sao Tome and Principe

NDCs, and other strategies, plans, and programs on the focus countries. More so, the approach for estimating CSA investment potential was with a consultation with a wide range of stakeholders to assess the status of climate finance sources and programs.

Experts were drawn from relevant government Ministries, stakeholders in the CSA sector, CSA technology providers, think tanks, civil society organizations (CSOs), Climate Bonds Initiative, and organizations like Africa Renewable Energy Initiative and other policy research institutions to take part in semi-structured face to face interviews. Further, national consultative and validation workshops were conducted with private and public sector players such as the UNFCCC, WB, AfDB, IFC, and other donors. To ensure a bottom-up approach, market players – early-stage, mid-stage, and matured companies – were consulted in developing priority actions for the implementation of CSA technologies. In every stakeholder consultation, a checklist was developed against which information was collected. The information collected was both qualitative and quantitative. To triangulate and complement the empirical findings, the results were further discussed with limited expert stakeholders to assess their opinions and thoughts.

---

## **CSA Financial Potential and Barriers Associated with CSA Financing**

### **Financing Potential for Climate-Smart Agriculture in Sub-Saharan Africa**

To assess climate smart potential, many adoption studies generally rely on the agricultural practices and opportunities that can be utilized by the private sector (Tesfaye et al. 2017; Pauw and Pegels 2013; Zougmore et al. 2018; Atteridge and Dzebo 2015; Intellectap 2010; Pauw 2014; Pauw et al. 2015). The evidence generated is qualitative that is rather weak failing to constitute a strong business case to complement the adaptation finance gap in the context of developing countries. It is important to note that the failure to have an argument based on quantitative potential in pursuing private sector engagement in climate-smart agriculture contributes to the adaptation paradox. It is true there are insightful estimates on the business potential of climate-smart agriculture but that is mostly within high level and political contexts. However, agricultural vulnerability is essentially within the local contexts. To engage the local private sector and institutions in implementing the adaptation needs, there is an absolute urgency to create awareness on the underlying climate-smart agriculture potential, investment trends, and agricultural practices with the maximum returns.

Table 3 presents quantified climate investment potential among 14 countries in SSA. It can be observed that Ethiopia has the greatest climate-smart agriculture investment potential of USD 26.4 million. It is followed by Nigeria, Kenya, Madagascar, and Ghana at 17.0, 8.9, 8.4, and 5.5 million USD, respectively. The rest of the countries have a CSA investment potential between the range of 0.3 and 2 million

**Table 3** Climate-smart agriculture investment potential

S. No.	Country	Climate-smart agriculture finance potential (USD millions)
1	Ethiopia	26,400
2	Nigeria	17,028
3	Kenya	8,910
4	Madagascar	8,360
5	Ghana	5,510
6	Rwanda	2,200
7	Senegal	2,092
8	Cameroon	1,800
9	Mozambique	1,760
10	Ivory Coast	1,656
11	Tanzania	1,500
12	Congo	1,563
13	Zambia	392
14	South Africa	NA
<b>Total</b>		<b>79,171</b>

up to the year 2030. In the views of the stakeholders, the cumulative investment potential of CSA is about 40%. Specifically, the private sector can tap into addressing climate change vulnerabilities that are tied to agriculture and water creating a win-win scenario for both the investors and farmers. The figures in Table 3 support the hypothesis that the CSA investment potential is quantifiable and varies across various countries in Africa. According to Quantum that ranks African countries based on Investment Index based on: economic growth, risk factor, business environment, demographic, social capital, and liquidity factor, South Africa, Kenya, and Ethiopia emerged among the top ten (Quantum Global 2018). Essentially, the private sector can single out these three countries on climate-smart sectors.

Climate financing comes from various sources, multilateral and bilateral, public and private, and possibly alternative sources such as remittances (Bendandi and Pauw 2016). According to the OECD (2018), public climate finance from developed to developing countries in 2017 was at USD 56.7 billion that was a 17% increase from the previous year. Public finance can be used to unlock additional climate funding especially from the private sources that would generally increase the domestic revenue base through proportionate increase of agricultural finance. Despite the continued flow of public financing into developing countries to promote climate adaptation, its documentation as climate-smart agricultural potential for private sector exploration remains unclear.

Table 4 shows that the highest CSA investment is evenly spread among the top five highest receivers. Zambia has the highest investment at 29.4 followed by Madagascar with 28.1, Tanzania 23.4, Nigeria 19.8, and Rwanda 17.31. However, it should be noted that the inflow of multilateral funds in form of adaptation fund supply is 75% grant, 20% concessional loan, and 5% equity. Consequently,

**Table 4** Investment trends in climate-smart agriculture in the shortlisted countries

S. No.	Country	Contributions to climate-smart agriculture per year in USD millions
1.	Zambia	29.40
2.	Madagascar	28.06
3.	Tanzania	23.42
4.	Nigeria	19.78
5.	Rwanda	17.31
6.	Ethiopia	17.26
7.	Mozambique	15.77
8.	Senegal	14.96
9.	Cote D'Ivoire	13.32
10.	Cameroon	9.67
11.	South Africa	7.99
12.	Ghana	7.06
13.	Kenya	5.57
14.	Congo	4.26
<b>Total</b>		<b>213.83</b>

classifying countries according to those with the highest grant inflows that are leaned to agriculture and water sectors, we have Tanzania, Zambia, Ethiopia, Madagascar, and Mozambique.

On average, there is a 98% funding gap in climate-smart agriculture. Out of which, 15–20% can be met by multilateral funds and investments from local governments, financial institutions, and private investors. Arguably, Sub-Saharan Africa will be the global destination for climate financing.

Table 5 identifies some key potential opportunities that could be explored by the private sector across Sub-Saharan Africa. In general, there are investment opportunities in integrated pest and disease control, soil fertility and water management, adoption of new agriculture technologies and practices in addition to farm diversification.

## **Barriers Hindering the Private Sector from Investing in CSA in Africa**

According to the World Bank (2016) observations, investment alone will not be effective in promoting sustainable agriculture. The investments will be rendered ineffective by other existing barriers that are important to untangle. Neglecting uncertainties and failing to factor in nonfinancial and financial-related barriers while making financial decisions may result in wrong investment models that have detrimental effects on both the investor and farmers. Among the many difficulties experienced in trying to close in the financing gap, there is need to reflect on three of the most common barriers: financial, policy and regulatory, government and institutional barriers. Collectively, these barriers directly or indirectly result to income and liquidity variability mostly among the majority of the agriculture sector players – smallholder farmers.

**Table 5** CSA implementation measures with the maximum potential for investment by the private sector

S. No.	Country	Climate-smart agriculture interventions with the maximum potential to attract private investment
1	Ethiopia	(a) Periodical application of biofertilizers (b) The precise application of fertilizer
2	Nigeria	(a) Agriculture-based research and development
3	Kenya	(a) Legume-based feeds for dairy cows (b) Organic manure composting and distribution (c) Crop rotation techniques
4	Madagascar	(a) Application of multi-hazard early warning systems and pest control (b) Integrated water resources management specifically in arid areas (c) Large-scale adoption of resilient agriculture
5	Ghana	(a) Agronomic-based support in soil and water conservation techniques (b) Enhancing agricultural productivity (c) Widespread better use of quality fertilizer among the smallholder farmers (d) Promoting agricultural diversification to boost income generation (e) Foster adoption of agriculture-based technologies in water management and small-scale irrigation
6	Rwanda	(a) Soil management in wetlands (b) Multiple mechanisms in pest and disease control (c) Adoption of green manure including crop biomass
7	Senegal	(a) Adoption of sustainable land management technologies (b) Enhancing the adoption of agriculture insurance policies (c) The wide reach of climate-based information (d) Trigger a market base for crop and forest products
8	Cameroon	N/A
9	Mozambique	(a) Adoption of drought-resistant crop varieties (b) Use of integrated pest control and organic manure (c) Management of crop-based biomass (d) Sustainable water management (e) Diversification of sources of livelihoods
10	Cote D'Ivoire	(a) Improvement in agricultural production technologies (b) Introduction of agricultural produce storage facilities (c) Popularizing climate-resilient crop varieties
11	Tanzania	(a) Management of soil fertility and extension of agriculture services (b) Introduction of in situ water harvesting techniques and agriculture-based insurance policies (c) Adoption of high yields drought-resistant seed varieties and crop diversification (d) Use of inter alia CSA and widespread knowledge
12	Congo	N/A
13	Zambia	(a) Widespread adoption of drought-resistant crops and agroforestry. (b) Increased biomass capacity. (c) Encouraging fire management and adoption of integrated pest and disease control.
14	South Africa	(a) Adoption of conservation agriculture and better cropping practices. (b) Diversification of farm activities. (c) Livestock and pasture management .

Evidence by Africa Climate Week shows that over 65% of African countries have started their implementation of the Nationally Determined Contributions (Africa Climate Week 2019). Moreover, 80% of the surveyed firms have attained substantial mileage in the adoption and implementation of climate change adaptation measures. However, the survey also established that more than half of African countries face problems in mobilizing both national and international funds. Further on, the Africa Climate Week study found out that over 75% of the surveyed countries did not have an efficient financing strategy with an additional 67% lacking agriculture-based financial instruments. Conclusively, despite the investment potential associated with CSA in Sub-Saharan Africa, it is worthwhile to note that access to climate finance at scale presents a major setback. Divulging more information on financial factors that have large uncertainty along with other intertwining obstacles will be of high value for enhancing investment decisions and policy advocacy. Some of the challenges facing the continent when it comes to CSA financing includes:

- (i) Overlapping policies on climate change that are weakly enforced.
- (ii) Inadequate and unstructured provision for climate funding in the respective country's national budgets.
- (iii) Insufficiency in terms of government capacity to satisfy the required standards and procedures needed in developing viable projects and bureaucratic funding processes.
- (iv) Inadequate knowledge and awareness on the sources of climate finances among the stakeholders in addition to constrained private sector engagement.
- (v) Lack of appreciation that climate change is both a developmental and environmental concern leading to a silo approach that impairs financing and problem-solving.

Looking more closely at the CSA barriers, most of the stakeholders agreed that financial-related barriers were the greatest hindrance towards unlocking the potential in climate-smart agriculture by the private sector. Secondly, about 80% of the stakeholders interviewed expressed that policy and regulatory setbacks were holding back the private sector from being involved in undertaking climate change interventions in Africa. Additionally, stakeholders highlighted that economic-, infrastructure-, and institutional-related constraints prevented the private sector interest in CSA. It was important to disaggregate the various financial, regulatory, and governance barriers.

Financing products and instruments for climate-smart projects financing from the local commercial banks do not only have high-interest rates and collateral pledges but also short lending tenures. Lending interest rates for the local banks across Africa is between 18% and 20% and in most cases require 100% collateral for one to acquire an agricultural loan. The local commercial banks view climate-smart projects as highly risky due to their limited experience in the newly emerged sector. Arguably, the inadequate data on risk-profile data for climate-smart projects contribute to the financier's views. Also, the target short-term payback period of between 1 and 3 years set for climate-smart projects does not fit with the loan tenors.

Unlike countries such as Bangladesh that experienced a large uptake of climate-smart approaches due to a huge number of microfinance institutions, in SSA, the microlending infrastructure is poorly developed. Microfinancing in the majority of the African countries is still at its infancy, and product sales targeting climate-smart agriculture is virtually nonexistent.

There are conspicuously limited national funds that have been mobilized and distributed at low costs to the private sector. National funds aimed at financing climate-smart agriculture could be of great help in invoking private sector participation with the high costs attracted by commercial bank alternations. However, in the majority of the African countries, national funds for smart agriculture are inactive or are lacking.

Under the current situation, CSA financing in Sub-Saharan African is based on donor funding which is mostly prohibitive due to high mainstreaming and upscaling costs. The import and export of capital in SSA countries are both bureaucratic-lengthy and costly. Climate-smart entrepreneurs and start-ups that are the engine behind innovation and efficient use of resources lack capital. Much of the funding into early-stage business models and start-ups is through private equity, venture capital, or angel investor community that lack the pool of resources necessary to satisfy all sectors. Innovators end up competing against each other dwindling each other's chances of survival. Measures such as promoting blended finance, introducing guarantee funds, encouraging fiscal incentives, establishing accessible local climate funds, and developing friendly investment policies will be key in overcoming the financial barriers and stimulating investor interest.

Key players in smart agriculture need policies that recognize and support the implementation of CSA practices. Investor-based services in smart agriculture like risk insurance and safety nets need considerable policy support. However, in the majority of the SSA countries, several CSA policy loopholes impair the actualization of the action plans. There is a problem with CSA coordination and mainstreaming into the general public. Therefore, the expenditure and planning systems are blurred both at the local, national, and regional levels. It will be critical to strengthening existing synergies to enhance food security programs. The absence of effective policies and regulations discourages lending and creates obstacles to the flow of cash to agriculture. For instance, lack of appreciation by the government of the agriculture economic and market potential lead to ignored subsidies that discourage the development of private sector-based solutions into enhancing climate adaptation.

Financial institutions have limited knowledge on climate-smart projects thereby hindering their investment interest. Both banks and microfinance lack the understanding of the operations of agriculture smart and continuously demonstrate an experience deficit. In such instances, the financial institutions need training on agriculture smart technologies to tailor-make suitable business models and financing options. Circulation of information will be necessary to get rid of the high-risk perception by the lending institutions. Key stakeholders, among them government ministries, nongovernmental organizations, and farmers cooperatives have a knowledge gap on CSA limiting its uptake. It is important for the government to be aware of the agriculture potential in order to promote the development of other sectors that



are not necessarily related to agriculture but are indirectly vital for its development, such as the infrastructure and communication networks.

---

## Conclusion

Modern day agriculture has to meet increased food demand due to burgeoning population and evolving diets amidst dwindling crop yield, diminishing natural resources, and constrained biodiversity. Worse is that the continuously warming climate is greatly undermining agricultural productivity with disastrous effects on land, crops, and farmers. Fortunately, adoption of climate-smart agriculture can be a significant part of solving the environmental crisis of climate change. Through sustainable agriculture, there is the capacity to increase agricultural productivity hence increasing incomes through built and adaptive farming resilience. However, this is not possible without substantial increase in the amount of climate-smart investment that will increase the access to finance. There exist huge financial gaps in CSA investment due to the perceptions of high risks and low profitability. Robust financial investment from the private sector can greatly accelerate the adoption of climate-smart agriculture leading to societal gains of poverty reduction by supporting the global food system. Through quantifiable evidence, this chapter has practically provided a translation of the investment potential into investor “language” with the sole objective of invoking private sector interest. The work carried out as the basis of this chapter has gone a step further to identify the maximum potential areas within the smart agriculture in respective countries with a conclusion of disaggregating the sector barriers.

Sub-Saharan Africa has a substantial climate finance investment potential for the private sector. Countries need to promote low carbon development, resource use efficiency, and resilience building in their development strategies and policies. International collaborations should seek to promote regional capacity building in accessing climate finance to promote sustainable development. Multilateral and national climate financing mechanisms should be based on a country’s commitment to climate change adaptation. There is a need to strengthen the regulatory environment by creating effective policies and subsidizing the private sector investment to spur adaptation action. SSA needs to foster regional and cross-border collaborations to enhance an integrated approach towards climate change-related issues. National governments need to harness the innovative capacity by raising capital for the private sector that is driving climate investments. Channels to facilitate climate finance into cities and urban areas where there is access to a greater number of people is necessary to greatly reduce the poverty levels.

The contribution of this work is on the conceptual clarifications of the CSA investment potential for the private sector. However, it fails to distinguish the opportunities as either for the domestic or/and international private sector. Again, the chapter outlines climate-smart agriculture potential at a national level. To greatly elicit the private sector, there is need to further breakdown the potential into local contexts. More so, future research can explore the financial potential of each of the

identified agricultural practices either regionally or nationally. Further, to objectively attract private investment into climate financing in developing countries, there is need to clearly define the short- and long-term investment activities that can be key for the financial institutions decision-making. The identified limitations create inadequacies in precisely defining the role of the private sector in their increasing engagement on climate finance.

National governments in Sub-Saharan Africa are supporting low carbon and climate-resilient development through local budget allocations, commitments to international programs and strategies that alone cannot achieve the sustainable development goals. They can further enhance their adaptation action through partnering with the private sector to alleviate the funding gap as a result of broadening public debt crises and increasing climate finance needs. This is by creating an enabling environment both in terms of policy, regulations, and infrastructure.

---

## References

- Africa Climate Week (2019) Africa climate week ends with calls for investments to tackle climate change – United Nations Sustainable Development. Retrieved from <https://www.un.org/sustainabledevelopment/blog/2019/04/africa-climate-week-ends-with-calls-for-investments-to-tackle-climate-change/>
- Atteridge A, Dzebo A (2015) When does private finance count as climate finance? Accounting for private contributions towards international pledges. SEI discussion brief. Stockholm
- Barkhordarian A, Von Storch H, Bhend J (2012) The expectation of future precipitation change over the Mediterranean region is different from what we observe. *Clim Dyn* 40(1–2):225–244. <https://doi.org/10.1007/s00382-012-1497-7>
- Barnard J, Manyire H, Tambi E, Bangali S (2015) Barriers to scaling up/out climate smart agriculture and strategies to enhance adoption in Africa. Retrieved from Forum for Agricultural Research in Africa, Accra, Ghana website <https://www.nepad.org/publication/barriers-scaling-up-out-climate-smart-agriculture-and-strategies-enhance-adoption>
- Bendandi B, Pauw P (2016) Remittances for adaptation: an ‘alternative source’ of international climate finance? In: Migration, risk management and climate change: evidence and policy responses, pp 195–211. [https://doi.org/10.1007/978-3-319-42922-9\\_10](https://doi.org/10.1007/978-3-319-42922-9_10)
- Branca G, Tennigkeit T, Mann W, Lipper L (2012) Identifying opportunities for climate-smart agriculture investments in Africa. FAO
- Buah SS, Ibrahim H, Derigubah M, Kuzie M, Segtaa JV, Bayala J et al (2017) Tillage and fertilizer effect on maize and soybean yields in the Guinea savanna zone of Ghana. *Agric Food Secur* 6 (1). <https://doi.org/10.1186/s40066-017-0094-8>
- Christiansen L, Ray AD, Smith JB, Haites E (2012) Accessing international funding for climate change adaptation. Climate and sustainable development. UNEP Risø Centre on Energy, Roskilde
- ECOWAS is in High Level Forum of Climate Smart Agriculture Stakeholders Intervention Framework for the Development of Climate Smart Agriculture under the West Agricultural Policy (ECOWAP/CAADP) implementation With technical facilitation by: In partnership with: Accelerating the implementation of ECOWAP/CAADP High Level Forum of Climate Smart Agriculture Stakeholders in West Africa Bamako (Mali), June 15–18, 2015 Intervention Framework for the Development of Climate Smart Agriculture under the West Africa Regional Agricultural Policy (ECOWAP/CAADP) implementation Process
- Elrafy M (2009) Impact of climate change: vulnerability and adaptation of coastal areas. Report of the Arab Forum for Environment and Development

- FAO (2012) Identifying opportunities for climate-smart agriculture investments in Africa. Retrieved from <http://www.fao.org/docrep/015/an112e/an112e00.pdf>
- FAO (2013) Climate smart agriculture source book. Retrieved from Food and Agriculture Organization of the United Nations website <http://www.fao.org/3/i3325e/i3325e.pdf>
- FAO, IFAD and WFP (2014) The State of Food Insecurity in the World 2014. Strengthening the enabling environment for food security and nutrition. Rome, FAO.
- Giller KE, Witter E, Corbeels M, Tittonnell P (2009) Conservation agriculture and smallholder farming in Africa: the heretics' view. *Field Crop Res* 114(1):23–34. <https://doi.org/10.1016/j.fcr.2009.06.017>
- Hoerling M, Hurrell J, Eischeid J, Phillips A (2006) Detection and attribution of twentieth-century northern and southern African rainfall change. *J Clim* 19(16):3989–4008. <https://doi.org/10.1175/jcli3842.1>
- Intellect (2010) Opportunities for private sector engagement in urban climate change resilience building. Author, Hyderabad
- IPCC (2014) Climate change 2014: impacts, adaptation and vulnerability. IPCC WGIAR5 technical summary. Retrieved from [http://ipccwg2.gov/AR5/images/uploads/WGIAR5-TS\\_FGDall.pdf](http://ipccwg2.gov/AR5/images/uploads/WGIAR5-TS_FGDall.pdf)
- Jalloh A, Roy-Macauley H, Sereme P (2012) Major agro-ecosystems of West and Central Africa: brief description, species richness, management, environmental limitations and concerns. *Agric Ecosyst Environ* 157:5–16. <https://doi.org/10.1016/j.agee.2011.11.019>
- Lobell DB, Bänziger M, Magorokosho C, Vivek B (2011) Nonlinear heat effects on African maize as evidenced by historical yield trials. *Nat Clim Chang* 1(1):42–45. <https://doi.org/10.1038/nclimate1043>
- Maguza-Tembo F, Edriss A, Mangisoni J (2017) Determinants of climate smart agriculture technology adoption in the drought prone districts of Malawi using a multivariate probit analysis. *Asian J Agric Ext Econ Soc* 16(3):1–12. <https://doi.org/10.9734/ajaees/2017/32489>
- Mapfumo P, Onyango M, Honkponou SK, El Mzouri EH, Githeko A, Rabeharisoa L et al (2015) Pathways to transformational change in the face of climate impacts: an analytical framework. *Clim Dev* 9(5):439–451. <https://doi.org/10.1080/17565529.2015.1040365>
- Mbow C, Smith P, Skole D, Duguma L, Bustamante M (2014) Achieving mitigation and adaptation to climate change through sustainable agroforestry practices in Africa. *Curr Opin Environ Sustain* 6:8–14. <https://doi.org/10.1016/j.cosust.2013.09.002>
- Mhlanga N, Blalock G, Christy R (2010) Understanding foreign direct investment in the southern African development community: an analysis based on project-level data. *Agric Econ* 41(3–4):337–347
- Milder J, Majanen T, Scherr S (2011) Performance and potential of conservation agriculture for climate change adaptation and mitigation in Sub-Saharan Africa: an assessment of WWF and CARE projects in support of the WWF-CARE alliance's rural futures initiative. Retrieved from <https://Barriers-to-scaling-up-out-CSA-in-Africa.pdf>
- Nciiaz AD, Wakindiki II (2015) Climate smart agriculture: achievements and prospects in Africa. *J Geosci Environ Protection* 03(06):99–105. <https://doi.org/10.4236/gep.2015.36016>
- OECD (2018) Public climate finance to developing countries is rising – OECD. Retrieved from <https://www.oecd.org/environment/public-climate-finance-to-developing-countries-is-rising.htm>
- Partey ST, Thevathasan NV, Zougmore RB, Preziosi RF (2016) Improving maize production through nitrogen supply from ten rarely-used organic resources in Ghana. *Agrofor Syst*. <https://doi.org/10.1007/s10457-016-0035-8>
- Pauw WP (2014) Not a panacea: private-sector engagement in adaptation and adaptation finance in developing countries. *Clim Pol* 15(5):583–603. <https://doi.org/10.1080/14693062.2014.953906>
- Pauw P, Pegels A (2013) Private sector engagement in climate change adaptation in least developed countries: an exploration. *Clim Dev* 5(4):257–267. <https://doi.org/10.1080/17565529.2013.826130>
- Pauw WP, Klein RJ, Vellinga P, Biermann F (2015) Private finance for adaptation: do private realities meet public ambitions? *Clim Chang* 134(4):489–503. <https://doi.org/10.1007/s10584-015-1539-3>
- Quantum Global (2018) Africa investment index 2018. Retrieved from Renew website [https://quantumglobalgroup.com/wp-content/uploads/2017/04/Africa\\_Investment\\_Index\\_April\\_2017\\_18.04.2017Final\\_Curves.pdf](https://quantumglobalgroup.com/wp-content/uploads/2017/04/Africa_Investment_Index_April_2017_18.04.2017Final_Curves.pdf)

- Radhouane L (2013) Climate change impacts on North African countries and on some Tunisian economic sectors. *J Agric Environ Int Dev* 107:101–113
- Sanou J, Bationo BA, Barry S, Nabie LD, Bayala J, Zougmore R (2016) Combining soil fertilization, cropping systems and improved varieties to minimize climate risks on farming productivity in northern region of Burkina Faso. *Agric Food Secur* 5(1). <https://doi.org/10.1186/s40066-016-0067-3>
- SER (2011) Advies Ontwikkeling door duurzaam ondernemen. Sociaal Economische Raad, Den Haag
- Surminski S (2013) Private-sector adaptation to climate risk. *Nat Clim Chang* 3(11):943–945. <https://doi.org/10.1038/nclimate2040>
- Sylla MB, Gaye AT, Jenkins GS (2012) On the fine-scale topography regulating changes in atmospheric hydrological cycle and extreme rainfall over West Africa in a regional climate model projections. *Int J Geophys* 2012:1–15. <https://doi.org/10.1155/2012/981649>
- Teklewold H, Mekonnen A, Kohlin G, Di Falco S (2017) Does adoption of multiple climate-smart practices improve farmers' climate resilience? Empirical evidence from the Nile basin of Ethiopia. *Clim Change Econ* 08(01):1750001. <https://doi.org/10.1142/s2010007817500014>
- Tesfaye K, Kassie M, Cairns JE, Michael M, Stirling C, Abate T et al (2017) Potential for scaling up climate smart agricultural practices: examples from sub-Saharan Africa. *Clim Change Manage*:185–203. [https://doi.org/10.1007/978-3-319-49520-0\\_12](https://doi.org/10.1007/978-3-319-49520-0_12)
- Thornton PK, Jones PG, Owiyo T, Kruska RL, Herrero M, Orindi V, Bhadwal S, Kristjanson P, Notenbaert A, Bekele N, Omolo A (2008) Climate change and poverty in Africa: Mapping hotspots of vulnerability. *Afr J Agr Res Econ* 311-2016–5524, 21. <https://doi.org/10.22004/ag.econ.56966>
- Torquebiau E (2015) Whither landscapes? Compiling requirements of the landscape approach. In: Minang P et al (eds) *Climate-smart landscapes*. ICRAF, Nairobi
- Tran NL, Rañola RF, Ole Sander B, Reiner W, Nguyen DT, Nong NK (2019) Determinants of adoption of climate-smart agriculture technologies in rice production in Vietnam. *Int J Clim Change Strategies Manag* 12(2):238–256. <https://doi.org/10.1108/ijccsm-01-2019-0003>
- UFCC (2007) Investment and financial flows UNFCCC to address climate change: an update Bonn. Technical Paper FCCC/ TP/2008/7
- UFCC (2011) Report of the conference of the parties on its sixteenth session, held in Cancun from 29 November to 10 December 2010
- UNDESA (2014) Urbanization prospects. The 2014 revision. Highlights. United Nations, New York
- UNEP FI (2009) The materiality of climate change. How finance copes with the ticking clock. United Nations Environment Programme Finance Initiative, Geneva
- United Nations, Department of Economic and Social Affairs, Population Division (2019) World urbanization prospects: The 2018 revision (ST/ESA/SER.A/420). United Nations, New York
- Wambugu C, Place F, Franzel S (2011) Research, development and scaling-up the adoption of fodder shrub innovations in East Africa. *Int J Agr Sustain* 9(1):100–109. <https://doi.org/10.3763/ijas.2010.0562>
- Williams T, Mul M, Cofie O, Kinyangi J, Zougmore R, Wamukoya G (2015) Climate smart agriculture in the African context background paper feeding Africa conference, 21–23 Oct 2015
- World Bank (2015) World development indicators 2015. Author, Washington, DC
- World Bank (2016) Making climate finance work in agriculture. Retrieved from <http://documents.worldbank.org/curated/en/986961467721999165/pdf/ACS19080-REVISED-OUO-9-Making-Climate-Finance-Work-in-Agriculture-Final-Version.pdf>
- Zougmore R, Traoré AS, Mbodj Y (eds.) (2015) Overview of the scientific, political and financial landscape of climate-smart agriculture in West Africa. Working Paper No. 118. CGIAR research program on climate change, agriculture and food security. Retrieved from <http://www.ccafs.cgiar.org>
- Zougmore RB, Partey ST, Ouédraogo M, Torquebiau E, Campbell BM (2018) Facing climate variability in sub-Saharan Africa: analysis of climate-smart agriculture opportunities to manage climate-related risks. *Cahiers Agric* 27(3):34001. <https://doi.org/10.1051/cagri/2018019>

**Open Access** This chapter is licensed under the terms of the Creative Commons Attribution 4.0 International License (<http://creativecommons.org/licenses/by/4.0/>), which permits use, sharing, adaptation, distribution and reproduction in any medium or format, as long as you give appropriate credit to the original author(s) and the source, provide a link to the Creative Commons license and indicate if changes were made.

The images or other third party material in this chapter are included in the chapter's Creative Commons license, unless indicated otherwise in a credit line to the material. If material is not included in the chapter's Creative Commons license and your intended use is not permitted by statutory regulation or exceeds the permitted use, you will need to obtain permission directly from the copyright holder.





# Africa–European Union Climate Change Partnership

# 102

Oluwole Olutola

## Contents

Introduction .....	2086
Liberal Institutionalism .....	2087
Paris Agreement, UN Climate Action Summit, and COP 25 .....	2088
Africa–EU Climate Change Partnership: A Revisit .....	2091
Conclusion and Policy Recommendations .....	2094
References .....	2095

## Abstract

The need to heighten climate action momentum is a key outcome of the Climate Action Summit organized by the United Nations (UN) in September, 2019. The same concern reverberated in most of the presentations and discussions at the twenty-fifth Conference of Parties (COP 25) – the annual climate summit under the United Nations Framework Convention on Climate Change (UNFCCC). This chapter seeks to investigate the relevance of the call for more climate action in terms of what further climate priorities and strategies are required in the context of the existing climate change partnership between Africa and the European Union (EU). It relies on liberal institutionalism as its theoretical framework and data from a range of purposely selected secondary sources as reference points. Beyond arguing the case for more climate action to further strengthening the Joint Africa–EU Strategy (JAES), particularly in the area of environmental partnership, this chapter emphasizes the need to align the required further climate action with the mitigation goals of the Paris Agreement and the UN transformative initiatives on

This chapter was previously published non-open access with exclusive rights reserved by the Publisher. It has been changed retrospectively to open access under a CC BY 4.0 license and the copyright holder is “The Author(s)”. For further details, please see the license information at the end of the chapter.

O. Olutola (✉)  
University of Johannesburg, Johannesburg, South Africa

the global climate action. It concludes with an insight into some policy recommendations, including the need for a dedicated and regional-based approach in tackling Africa's climate change beyond the conventional worldwide UNFCCC (United Nations Convention on Climate Change) framework that has failed to deliver tangible results for some time past.

---

**Keywords**

Climate change · Liberal institutionalism · COP25 · Joint Africa–EU Strategy · Paris Agreement

---

**Introduction**

Addressing climate change as an existential threat to this generation (UNCC 2019a) and the future generation given its transgenerational implications is more urgent than ever. In recognizing this growing climate concern, the United Nations (UN) convened a global climate action held in New York on 23 September 2019. The primary objective was aimed at mobilizing wide-range support for the multilateral climate change process. In the end, the summit emphasized the need to increase mitigation ambition as well as accelerate climate action involving a range of stakeholders – state and nonstate alike, including multilateral entities (UN 2019). Less than 3 months after, similar concern reverberated in most of the speeches and statements given at the twenty-fifth Conference of Parties (COP 25) – the annual climate summit under the United Nations Framework Convention on Climate Change (UNFCCC) – which took place in Madrid from 2 to 13 December 2019. Generally described as the launchpad for significantly more climate ambition, COP 25 also ended with a call for improved climate action (CarbonBrief 2019).

This separate but joint call for more climate ambition and action could not have happened at a better time, considering the mounting threats of climate change to the global system, regional and subregional entities. Besides, the call is consistent with the mitigation goals of the Paris Agreement that was decided at COP 21 in December 2015 as the first-ever universally agreed climate deal after more than two decades of unduly prolonged negotiations that characterized the previous COP meetings (Amusan and Olutola 2016). Under the Paris Agreement, state entities commit to ensure that the global average temperature is pegged to 2 °C above preindustrial levels and, if possible, further down to 1.5 °C still above preindustrial levels (UNFCCC 2015). However, the collective efforts to meet the set mitigation target are currently insufficient (Boyd et al. 2015; Schleussner et al. 2016). Recent finding shows that there must be a cut in carbon emissions to about 45% and net zero by 2030 and 2050, respectively, to save this century from the irreversible and catastrophic impacts of climate change (IPCC 2018).

From the outcomes of the aforementioned summits and the IPCC carbon cut projection, it is deduced that both the past and current efforts – at all levels – to combat climate change remain inadequate and far less than what should be the case. The significant attention drawn to the mounting dangers of climate change and the

multistakeholder approach in dealing with the phenomenon as a common enemy and global emergency in particular points to establish the summits' acknowledgment of multilateral entities as important rallying points for the desired enhanced climate action.

This chapter presents the case of Africa and the European Union (EU) partnership focusing on climate change as one of the priorities in the relationship between the two continental partners. It seeks to examine the relevance or otherwise of the call for more climate ambition and action in this particular case, and what further climate priorities and strategies, if any, are required. The chapter is structured into five sections as follows: section one contains the above introduction; section two systematically examines the key constructs of liberal institutionalism as a theoretical basis for this study; section three gives an overview of the UN climate action summit and COP 25 in the context of the Paris Agreement; section four appraises Africa–EU climate change partnership in light of the call for more climate action; and section five closes with a conclusion including an insight into key policy recommendations.

---

## Liberal Institutionalism

Liberal institutionalism represents one of the theoretical strands of the liberal school of thought. Generally, liberalism introduced new paradigm of debates to the body of international relations theories, as it underscores the relevance of nonmilitary (security) approach to handling issues and matters of common priority within the international system. Liberalists' main concern is to construct a model of international relations with capacity to mitigate the unchecked use of military force as a foreign policy instrument by state actors.

For most liberal institutionalists, cooperation between state and nonstate actors remains the most important and mutually beneficial ordering feature of the international system (Keohane 1984; Keohane and Martin 1995). This interstate cooperation is facilitated through international institutions and regimes, defined as a set of implicit or explicit principles, norms, rules, and decision-making procedures around which actors' expectations converge regarding any aspect of international relations (Krasner 1983: 2). The implication is that international institutions and regimes are conceived as the primary means of limiting the power of states at both domestic and international levels, thereby mitigating anarchy in the international system (Burchill 2005: 65).

Besides, liberal institutionalism places emphasis on international institutions which have the ability to help overcome selfish state behavior by bringing them together in a cooperative manner in pursuit of shared foreign policy objectives otherwise unattainable in isolation. In other words, international institutions serve as entities for mobilization networks, within which transgovernmental policy coordination and coalition building could take place (Keohane and Nye 1987: 738). In addition to providing multilateral platforms through which states deal with collective action problems that threaten stable patterns of cooperation, international institutions also perform such roles as coordination and monitoring which together make them to become "valuable foundation" for international cooperation (Martin 2007: 111).



Another key assumption of liberal institutionalism is the existence of multiple channels of contact through which states and societies are interconnected (Keohane and Nye 1987: 731). This brings to focus the term complex interdependence and the argument that the ranking of global issues as high and low politics is uncalled for, particularly in a world of multiple issues imperfectly linked and characterized by transnational and transgovernmental coalitions (Grieco 1988: 490).

However, liberal institutionalists agree that interstate cooperation is constrained by cheating and noncompliance with international agreements given the self-enforcing and anarchic nature of the international system. The situation is further worsened by the lack of guarantee to ensure that state individual tendencies to maximize the gains of cooperation at the expense of other participating actors are regulated in such a way that benefits are shared equally.

These shortcomings notwithstanding, liberal institutionalists strongly believe that cooperation between states is still possible even though it is something that happens gradually. In their analysis, cooperation would first be achieved in technical areas where it was mutually convenient and, if successful, could be extended to other functional areas of mutual benefits (Burchill 2005: 64). Indeed, the emphasis on international institutions as an important rallying point for interstate cooperation and, also, a potentially effective mechanism for containing global emergencies brings to relevance the focus on Africa and the EU.

While the Africa–EU climate change partnership is not a standalone multilateral institution in itself, it represents a key element and one of the important thematic priorities under the Joint Africa–European Union Strategy (JAES) adopted at the second EU–Africa summit in Lisbon in 2007. Section four of this chapter provides more explanations on the JAES. However, it is important to stress that Africa and Europe as two key multilateral partners depend on the instrumentality of the African Union and the EU to provide the needed institutional framework for the implementation of JAES and, more specifically, the partnership on climate change and other related climate activities being discussed in this chapter.

---

## **Paris Agreement, UN Climate Action Summit, and COP 25**

As a special creation of the UN, the UNFCCC is responsible for the global negotiations in response to climate change. Since its establishment in 1992, the global climate change process under the UNFCCC framework has experienced a back-and-forth approach to climate negotiations and, so, action. But after nearly two and half decades of interrupted negotiations, the Paris Agreement was agreed as a globally accepted climate action plan in 2015. By the agreement, state entities commit to ensure that the global average temperature is pegged to 2 °C above preindustrial levels and, if possible, to 1.5 °C above preindustrial levels (UNFCCC 2015).

To attain this long-term mitigation ambition, each party to the UNFCCC is under an obligation to develop and commit to a nationally determined contribution (NDC), which should be communicated to the UNFCCC secretariat and progressively maintained. The provisions of the agreement include a ratchet-up mechanism to

periodically review and update the NDCs every 5 years effectively from 2018 upward. While the unanimity exists in terms of perception of NDCs as a collective response towards achieving the Paris climate goals, the common understanding of what exactly constitute the NDCs is still lacking among the UNFCCC parties. Besides, efforts to ensure its transparency, particularly in the context of national climate framework and objectives, are still quite challenging.

Besides, the current emission reduction pledges captured in the NDCs for the period up until 2030 though represent progress compared with “business as usual,” but insufficient to secure the achievement of the mitigation goal set by the Paris Agreement (Boyd et al. 2015; Schleussner et al. 2016; UN 2019). Nevertheless, it forms the basis of any serious global struggle against climate change, especially on the part of state actors. It also points to establish that collective efforts beyond the UNFCCC are, indeed, needed to effectively address climate change. Stabilizing the global climate at safe levels requires wider international cooperation to complement the global climate change process within the UNFCCC (Moncel and van Asselt 2012).

Unfortunately, not so much of the mitigation ambition proposed under the Paris Agreement has been achieved. The full implementation of the Paris Agreement is yet to be actualized, as efforts are still ongoing at the level of the annual Conference of Parties to finalize its operational guidelines. The latest in the series was COP25 held in 2019 as the Launchpad for significantly more climate ambition. It is important to note that the Trump-led US in mid-2017 formally disclosed the country’s intention to withdraw from further participating in the Paris Agreement (Lawrence and Wong 2017). While there is no consensus in research yet as to whether the US withdrawal represents an opportunity or a setback for the Paris Agreement in particular and the global climate action in general, some scholars have raised concerns around the potential damage that could result from the US nonparticipation in raising finance to support global climate action (Olutola 2020; Urpelainen and van de Graaf 2018).

Yet, the worsening impacts of climate variation are becoming increasingly evident in some parts of the world. Recent cases include the Hurricane Dorian that struck the Bahamas and Cyclone Idai landfall in Mozambique with their attendant unprecedented catastrophes. Obviously worried by this growing severity of climate change impacts, the UN as a universal body gathered together wide-ranging stakeholders – state and nonstate – in what was dubbed the global climate action summit held in December 2019. The intention was to provide support for the Paris Agreement and the UN 2030 Agenda for sustainable development. In particular, it offered state participants a unique opportunity to discuss how best to enhance their respective NDCs by 2020 (short-term) in keeping faith with 2030 (mid-term) mitigation goal of 45% emission reduction as well as the 2050 (long-term) mitigation objective of net zero relative to GHG emissions.

The summit focused on nine key areas where urgent climate action is required. These include energy transition; climate finance and carbon pricing; resilience and adaptation; nature-based solutions; mitigation strategy; among others (UN 2019: 3). Buried under 12 themes, the summit’s climate action objectives are expected to be achieved through transformative initiatives for which stakeholders would be held

responsible. These transformative initiatives include: the need for improved climate finance as a key element for the transition to net-zero emissions and climate resilient economies; pledges to decarbonize investment portfolios and systematically include environmental impacts in investment decision-making; setting limits for the use of coal, or phase it out altogether, including the development of a collective support system to help provide developing countries with the option of exiting coal; plans to eliminate deforestation, preserving biodiversity, and restoration of natural ecosystems particularly through planting of trees; integration of climate risks and resilience initiatives in decision-making systems and national development frameworks across the continent, including climate resilient development pathways for least developed countries (LCDs); and provision of insurance for the most vulnerable and support to prevent climate-related disasters, among others. More importantly, the summit succeeded in establishing an all-encompassing steering committee to provide strategic guidance and oversight of its planned action and activities as well as two advisory groups – science and ambition – to provide technical expertise.

Aside from stressing the need for the urgency of climate action in the identified areas, the summit called attention to the strategic importance of renewed leadership at all levels and across the board including collaboration between relevant stakeholders. Its multistakeholder transformative initiatives with commitments from 70 and 75 countries – mostly small and developing countries responsible for far below 15% of aggregate carbon emissions worldwide – to work towards more aggressive NDCs and net-zero emissions by 2020 and 2050 respectively, are nevertheless remarkable. Granted that the agreed initiatives are no doubt consistent with the Paris mitigation objectives, it is of concern that the summit could not secure concrete and immediate mitigation pledges from the world's leading GHG emitters – mostly the G20 countries (including the full EU) which together produce close to 30 kilotons of CO<sub>2</sub> annually, as of 2015, thereby responsible for about 81% of all global carbon emissions (Globalist 2018).

Unfortunately, the COP25 – which was to provide a critical platform for the operationalization of the Paris Agreement with the year 2020 set as the deadline – fell short of expectations. Despite the momentum ignited by the UN climate action summit, the once in a year climate meeting could not achieve much. The climate ambition alliance (UNCC 2019b) presented during the meeting is chiefly a recapitulation of the multistakeholder pledges made at the UN climate action summit. No consensus was reached regarding the planned increase in mitigation commitments, while virtually all other outstanding issues emanating from the Paris Agreement were also left unresolved. These issues range from failure to secure: increased NDCs pledges, especially from the world's biggest emitters; the final decision on the rulebook, regarded as the operating manual for the implementation of the Paris climate deal; specific operating guidelines for loss and damage; and new and enhanced climate finance goals, among others.

This lack of progress is worrisome and, certainly, not a good complementarity of the UN transformative initiatives concerning the global climate action. Besides, it exacerbates the concern raised in the emissions gap report that the existing NDCs, even if met, would not be enough to deliver the Paris mitigation goal. Based on the

report, emissions need to reduce to 2.7% each year from 2020 to 2030 and 7.6% each year on the average for the 2 °C and the 1.5 °C goals, respectively, to meet the Paris Agreement’s mitigation target (UNEP 2019: 26). Hence, the urge for increased ambition pledges is critical to closing the gap between the emission targets captured in the NDCs currently and the mitigation goal set by the Paris Agreement.

Just as COP25 was winding up, the EU signaled its resolve to achieve net-zero emissions by 2050. Encapsulated in what is known as the European Green Deal, the EU seeks to commit about 25% of its long-term budget to climate-related objectives. As a deliberate strategy to boost the EU’s NDC pledge for 2030, the deal contains a proposal to reduce the bloc’s carbon emissions from its current target of 40% to a higher target of at least 50% and towards 55% compared with 1990 levels (Claeys et al. 2019; EC 2019). If this deal is actualized, coupled with the fact that other key emitters – most especially the USA – are showing no indication to seriously commit to any increased mitigation plan, the EU would have once again reestablished its pivotal role in providing leadership to the global action against climate change. This self-assumed responsibility brings to focus the climate change partnership between the EU and Africa (another continent that is at the center of any discussions on the global climate action because of its high exposure to climate change impacts and little or no capacity in terms of adaptation).

---

## Africa–EU Climate Change Partnership: A Revisit

The partnership between Africa and the EU was launched in 2000 – two decades ago – at the maiden edition of the Africa–EU meeting in Cairo. Seven years after, the two partners at the second edition in Lisbon adopted a Joint Africa–EU Strategy (JAES). The JAES represents the guiding instrument for the overarching long-term and political framework of the collaboration between the two continental entities (EU 2007). It outlines the basic principles (ownership, partnership, and solidarity) and general objectives of the partnership. These include a resolution on the part of the two partners to formalize the strategic partnership by moving away from the usual donor and recipient – give and take – approach; treat Africa as one entity; enhance their partnership at all levels on the basis of jointly identified mutual and complementary interests; and take their multilateral engagement to a new strategic level with reinforced policy dialogues and action plans, among other objectives (Bach 2010; EU 2013–2019).

Interestingly, climate change (and the environment) made the list as one of the thematic priorities of common concern in the Africa–EU partnership. Others include peace and insecurity; democratic governance and human rights; regional economic integration, trade, and infrastructure; millennium development goals; energy; mitigation, mobility, and employment; and science, information society, and space. Africa–EU climate change partnership can be viewed from at least two perspectives: the collaborative efforts of the two partners towards the global climate change process within the UNFCCC and the willingness on the part of the two partners to work together to combat climate change as a common enemy. Even though the

vision of a joint agenda/position on climate change could not be achieved as envisaged partly due to lack of clarity on their common interests and internal divisions, the JAES's climate change partnership perhaps succeeded in building a common understanding of various climate-related issues and of their respective positions in the UNFCCC multilateral negotiations (Tondel et al. 2015).

The partnership has produced some level of significant progress over the years, as manifested in the launch of several climate-linked initiatives and programs. These include TerrAfrica, the Great Green Wall for the Sahara and the Sahel Initiative (GGWSSI), and Climate for Development in Africa (ClimDev-Africa). While TerrAfrica was created in 2005 as a platform for better coordination of efforts geared towards the upscaling of finance and mainstreaming of effective and efficient country-driven sustainable land and water management (SLWM) across the continent (NEPAD 2019), the GGWSSI was launched in 2007 as a "bulwark against the encroaching desert" (Bilski 2018), thereby strengthening climate resilience in Africa. ClimDev-Africa was designed as a tripartite arrangement of the United Nations Economic Commission for Africa (UNECA), the African Union Commission (AUC), and the African Development Bank (AfDB) through ClimDev Special Fund in 2010. Essentially, it aims to provide a solid foundation for an appropriate regional climate change response (UNECA 2014).

In particular, TerrAfrica and GGWSSI contributed significantly to strengthening the collaboration between the two partners, especially in the areas of sustainable land management and fight against desert encroachment in sub-Saharan Africa, respectively. Similarly, the EU financial intervention of €8 million through the ClimDev-Africa initiative was instrumental to the establishment of the African Climate Policy Center (ACPC) in Addis Ababa in 2012 and, by extension, the development of climate-based knowledge in support of policy-making in Africa (EU 2014: 24–25). By 2013, a €28 million contribution to ClimDev-Africa was launched to provide support (financial and technical) to the African Union (AU) – as the continent's collective representative – and many of its member states to enhance their capacities to make climate-sensitive policies. In 2015, the EU introduced another funding package amounting to €80 million to build disaster resilience in sub-Saharan Africa (EC 2015). Since the rebirth of the Organization of African Unity (OAU) as AU in 2002, Africa has received climate-related EU aid amounting to €3.7 billion (Khadiagala 2018: 440).

Many poor African countries with relatively high vulnerability to climate change (Chad, Cape Verde, Democratic Republic of Congo, Djibouti, Mali, Mauritania, Mozambique, Sudan, and Uganda, among others) have particularly benefited one way or the other from the EU global ecological charity administered through the Global Climate Change Alliance (GCCA 2018). The GCCA was created in 2007 to support climate change projects and programs in the world's most climate-vulnerable countries of which many are found in Africa. It provides technical and financial support for national, multicountry, and regional climate change projects and programs using a set of eligibility criteria (Miola et al., 2015). The GCCA is focused on five priorities, namely: mainstreaming climate change into poverty reduction and development strategies; adaptation, building on the National Adaptation Programs

of Action (NAPAs) and other national plans; disaster risk reduction (DRR); reducing emissions from deforestation and forest degradation (REDD); and enhancing participation in the Global Carbon Market and Clean Development Mechanism (CDM).

Despite the progress recorded, climate change remains a challenging thematic priority for the EU–Africa partnership. For the most part, the partnership has been plagued by some issues ranging from cumbersome institutional structure; inefficient policy processes; mistrust; capacity differentials; lack of clarity on shared purpose and priorities; a deficit of political support on both sides; and the Brexit anxiety, among others. To address these issues and achieve common objectives in the important area of climate change, Africa and the EU must work more closely and commit to more climate action in line with the UN transformative initiatives.

The call for more climate action is therefore a wake-up opportunity for Africa and the EU to take deliberate action towards deepening the existing climate change collaboration between the two partners. Africa and the EU share affinities in the important aspects of their historical connections, geographical closeness, political vision, and interests, including the great potential for a common future. Up until this period, the two partners have played a pivotal role in the global fight against climate change. It is high time to consolidate their joint efforts and continue to take the lead in the global climate change struggle. One way to achieve this is by bringing the current approach in terms of climate action and strategies within the Africa–EU partnership into alignment with the agreed transformative initiatives on the global climate action. More specifically, it is high time that the Africa–EU climate change partnership complements the efforts of the UN steering committee on the global climate action, especially in providing strategic guidance and oversight of the implementation of the global transformative initiatives as they affect Africa.

In addition, Africa and the EU need to commit to a common climate change agenda and joint implementation framework that not only support the components of the UN transformative initiatives, but also consistent with the mitigation goal set by the Paris Agreement. Achieving this may face with the challenge of difference in priorities. As a marginal contributor to the global carbon emissions and, ironically, a core victim of climate change adverse impacts, Africa over the years has been consistent in its advocacy of adaptation bailout. The AU as the continent’s collective representative minced no words in stating this regional climate change position in its Agenda 2063 (AUC 2015). While the EU has no doubt demonstrated support for the continent’s adaptation priority, its primary focus like other developed parties to the UNFCCC is geared towards addressing mitigation in the form of emissions’ reduction. This priority gap needs to be addressed.

Narratives about Africa and Europe are changing in recent years. The African continent, for instance, have demonstrated remarkable progress in some aspects such as governance and democratic accountability, human development, and sustained domestic economic growth. A case in point regarding changes in Europe is no doubt the Brexit phenomenon. There is therefore the need to adjust the EU–Africa relations in the context of these new developments. Africa–EU climate change policies in particular should be driven by common interests and objectives, with clearly defined priorities and action plans that recognize differences regarding the strengths and

weaknesses of individual partners. More desirable is a balanced Africa–EU climate change relation. While it is important that financial and technical supports should be provided to African countries to enable them fulfill their climate action pledges, Africa cannot continue to depend entirely on bailout in its efforts to cope and adapt to climate change under the excuse of extreme vulnerability. A truly multilateral partnership entails collective action and shared responsibility in all aspects. With no prejudice to the fact that many African countries are relatively poor and faced with daunting challenges of sustainable development, it is time for Africa to stop paying lip service to the mantra “African solutions to African problems.”

Actions in terms of climate action and strategies within the Africa–EU partnership should not only be aligned with the transformation initiatives, but also and above all, be structured around a dedicated and regional approach. This should go beyond the conventional worldwide UNFCCC (United Nations Convention on Climate Change) framework that has failed to deliver tangible results for some time past. Incidentally, climate change is one of the few areas where a continental position has been agreed. Mobilizing African solidarity and unity on any issues has never been easy given the continent’s diverse national interests and agendas.

---

## Conclusion and Policy Recommendations

Climate change continues to threaten both the present and future generations. Its growing worsening impacts in recent years have drawn remarkable global attention. One of such was the 2019 UN Climate Action Summit that drew participant from across the world and ended with a call for more global climate action, particularly on the part of state-stakeholders. Though a yearly event but in recognizing the increasing dangers of climate change and the need for accelerated global intervention, the COP 25 held in December same year (2019) concluded with a resolution calling for more climate ambition and action in line with the mitigation goal of the Paris Agreement and the UN 2030 Agenda for sustainable development.

On its part, the UN climate action summit succeeded in introducing a set of transformative initiatives for which state and nonstate stakeholders are responsible. But, it failed to secure concrete and immediate mitigation pledges from the world’s top greenhouse gas (GHG) emitters. In the case of COP25, not much progress was achieved beyond the presentation of the Climate Ambition Alliance (CAA). The CAA in its presentation succeeded in merely reemphasizing the multistakeholder pledges made at the UN climate action summit. This chapter argues that the lack of complementarity between the identified two summits is not only worrisome, but also exacerbates the concern raised in the emissions gap report that the existing mitigation pledges otherwise known as NDCs, even if met, would not be enough to deliver the Paris goal. The urge for increased ambition pledges and climate action is therefore critical to closing the gap between the current assemblage of NDCs and the mitigation goal set by the Paris Agreement.

Furthermore, it is argued that though the separate but joint call for more climate ambition and action is a global question, it provides Africa and the EU in particular a

fresh opportunity to deepen their existing climate change partnership. This chapter not only underscores the strategic positions and relevance of these two longstanding partners to the global fight against climate change, but it also highlights that the EU through the unveiling of the European Green Deal already set the pace for increased mitigation pledges involving world's leading emitters. It is yet to be seen though how much of the proposed mitigation objectives would be realized ultimately.

Going forward, this chapter recommends that Africa–EU climate change policies be aligned with the UN transformative initiatives on the global climate action, particularly the African components. Besides, there is the need for a more assertive and balanced Africa–EU relation, particularly in the context of climate change. Such relation should be based on common climate agendas, with clearly defined priorities and action plans including a joint implementation framework that not only support the transformative initiatives but also consistent with the mitigation goal of the Paris Agreement. Africa–EU climate change partnership should be adjusted to complement the efforts of the UN steering committee on global climate action, especially in terms of providing strategic guidance and monitoring of the implementation of the global transformative initiatives in Africa. While the EU is encouraged to continue to provide both financial and technical supports to African countries to enable them fulfill their pledges relative to the global climate action, there is need for Africa to also look inward for solutions. More focus should be directed at unveiling regional-based solutions to the climate change challenges facing the African continent beyond the UNFCCC framework.

Lastly, as the mitigation ambition proposed in the framework of the Paris Agreement is far from being achieved and that the full implementation of the Paris Agreement has yet to be concretized, because efforts are always underway at the annual COP to finalize its operational guidelines; more plausible concepts such as a truly multilateral partnership which involve collective actions and shared responsibilities in all aspects should be considered to have a good Africa–EU partnership on climate change in light of the call for more climate action.

---

## References

- Amusan L, Olutola O (2016) Addressing Climate Change in Southern Africa: Any Role for South Africa in the Post-Paris Agreement? *India Quarterly* 72(4):395–409. <https://doi.org/10.1177/0974928416671592>
- AUC (African Union Commission) (2015) Agenda 2063: the Africa we want. Popular version. AUC, Addis Ababa
- Bach D (2010) The EU's 'strategic partnership' with Africa: Model or Placebo? GARNET Working Chapter No. 80/10, September
- Bilski A (2018) Africa's great green wall: a work in progress. *Landscape News*, August
- Boyd R, Turner JC, Ward B (2015) Intended nationally determined contributions: what are the implications for greenhouse gas emissions in 2030? Policy Chapter, October. ESRC Centre for Climate Change Economics and Policy and Grantham Research Institute on Climate Change and the Environment
- Burchill S (2005) Liberalism. In: Burchill S, Linklater A, Devetak R, Donnelly J, Paterson M, Reus-Smit C, True J (eds) *Theories of international relations*, 3rd edn. Palgrave Macmillan, Hampshire and New York, pp 55–83



- CarbonBrief (2019) COP 25: key outcomes agreed at the UN climate talks in Madrid. 15 December. Retrieved from <https://www.carbonbrief.org/cop25-key-outcomes-agreed-at-the-un-climate-talks-in-madrid>
- Claeys G, Tagliapietra S, Zachmann G (2019) How to make the European green Deal work. Policy contribution issue no. 13, November. Bruegel, Brussels
- EC (European Commission) (2015) African Union Commission and European Commission meet to bring new impetus to the EU-Africa partnership. Press release, 21 April. EC, Brussels
- EC (European Commission) (2019) The European Green Deal. Communication from the Commission to The European Parliament, The European Council, The Council, The European Economic and Social Committee and The Committee of the Regions. COM (2019) 640 final. EC, Brussels
- EU (European Union) (2007) The Africa-EU strategic partnership: a joint Africa-EU strategy. 16344/07 (Presse 291), 9 December. Council of the European Union, Brussels
- EU (European Union) (2013–2019) The partnership and joint Africa-EU strategy. Retrieved from <https://www.africa-eu-partnership.org/en/partnership-and-joint-africa-eu-strategy>
- EU (European Union) (2014) The Africa-EU partnership: 2 unions, 1 vision. Summit edition. Publications Office of the European Union, Luxembourg
- GCCA (Global Climate Change Alliance) (2018) Our programs. Retrieved from <http://www.gcca.eu/programmes>
- Globalist (2018) The scale of G20 Greenhouse Gas Emissions: can the G20 summit help advance international cooperation on the environment? 2 December. Retrieved from <https://www.theglobalist.com/the-scale-of-g20-greenhouse-gas-emissions/>
- Grieco JM (1988) Anarchy and the limits of cooperation: a realist critique of the newest liberal institutionalism. *International Organisation* 42(3):485–507
- IPCC (Intergovernmental Panel on Climate Change) (2018) Global warming of 1.5°C: an IPCC special report on the impacts of global warming of 1.5°C above pre-industrial levels and related global greenhouse gas emission pathways, in the context of strengthening the global response to the threat of climate change, sustainable development, and efforts to eradicate poverty. IPCC, Switzerland
- Keohane RO (1984) *After hegemony: cooperation and discord in the world political economy*. Princeton University Press, Princeton
- Keohane RO, Martin LL (1995) The promise of institutionalist theory. *Int Secur* 20(1):39–51. <https://doi.org/10.2307/2539214>
- Keohane RO, Nye JS Jr (1987) Power and interdependence revisited. *Int Organ* 41(4):725–753
- Khadiagala GM (2018) Europe-African relations in the era of uncertainty. In: Nagar D, Mutasa C (eds) *Africa and the world: bilateral and multilateral international diplomacy*. Palgrave Macmillan, Chaim, pp 433–453
- Krasner SD (1983) Structural causes and regime consequences: regimes as intervening variables. In: Krasner SD (ed) *International regimes*. Cornell University Press, Ithaca and London, pp 1–21
- Lawrence P, Wong D (2017) Soft law in the Paris climate agreement: strength or weakness? *Rev Eur Comparat Int Environ Law* 26(3):276–286. <https://doi.org/10.1111/reel.12210>
- Martin L (2007) Neoliberalism. In: Dunne T, Kurki M, Smith S (eds) *International relations theories: discipline and diversity*. Oxford University Press, Oxford, pp 109–126
- Miola A, Papadimitriou E, Mandrici A, McCormick N, Gobron N (2015) Index for the EU global climate change alliance plus flagship initiative. Publications Office of the European Union, Luxembourg
- Moncel R, van Asselt H (2012) All hands on deck! Mobilising climate change action beyond the UNFCCC. *Rev Eur Comparat Int Environ Law* 21(3):163–176. <https://doi.org/10.1111/reel.12011>
- NEPAD (New Partnership for Africa's Development) (2019) *TerrAfrica*. African Union Development Agency/NEPAD, Midrand. Retrieved from <https://www.nepad.org/programme/terrafrica>
- Olutola O (2020) U.S. withdrawal from the Paris agreement: implications for climate finance in Africa. *Africa Review* 12(1):18–36. <https://doi.org/10.1080/09744053.2019.1685334>

- Schleussner C, Rogelj J, Schaeffer M et al (2016) Science and policy characteristics of the Paris agreement temperature goal. *Nat Clim Chang* 6:827–835. <https://doi.org/10.1038/nclimate3096>
- Tondel F, Knaepen H, van Wyk L (2015) Africa and Europe combating climate change: towards a common agenda in 2015. Discussion chapter no. 177, May. European Centre for Development Policy Management, Maastricht
- UN (United Nations) (2019) Report of the Secretary-General on the 2019 Climate Action Summit and the way forward in 2020. Retrieved from [https://www.un.org/en/climatechange/assets/pdf/cas\\_report\\_11\\_dec.pdf](https://www.un.org/en/climatechange/assets/pdf/cas_report_11_dec.pdf)
- UNCC (United Nations Climate Change) (2019a) Climate action and support trends: based on national reports submitted to the UNFCCC secretariat under the current reporting framework. UNCC Secretariat, Bonn
- UNCC (United Nations Climate Change) (2019b) Climate ambition alliance: nations renew their push to upscale action by 2020 and achieve net zero CO<sub>2</sub> emissions by 2050. External Press Release, 11 December. Retrieved from <https://unfccc.int/news/climate-ambition-alliance-nations-renew-their-push-to-upscale-action-by-2020-and-achieve-net-zero>
- UNECA (United Nations Economic Commission for Africa) (2014) *ClimDev-Africa annual report*. 1 January – 31 December. UNECA, Addis Ababa
- UNEP (United Nations Environment Programme) (2019) *Emissions gap report 2019*. UNEP, Nairobi. Retrieved from <https://unepdpu.org/wp-content/uploads/2019/12/egr-2019.pdf>
- United Nations Framework Convention on Climate Change (UNFCCC) (2015) Conference of the parties: report of the conference of the parties on its twenty-first session. Held in Paris from 30 November to 11 December. FCCC/CP/2015/L.9/Rev.1. Retrieved from <http://unfccc.int/resource/docs/2010/cop16/eng/07a01.pdf>
- Urpelainen J, van de Graaf T (2018) United States non-cooperation and the Paris agreement. *Clim Pol* 18(7):839–851. <https://doi.org/10.1080/14693062.2017.1406843>

**Open Access** This chapter is licensed under the terms of the Creative Commons Attribution 4.0 International License (<http://creativecommons.org/licenses/by/4.0/>), which permits use, sharing, adaptation, distribution and reproduction in any medium or format, as long as you give appropriate credit to the original author(s) and the source, provide a link to the Creative Commons license and indicate if changes were made.

The images or other third party material in this chapter are included in the chapter's Creative Commons license, unless indicated otherwise in a credit line to the material. If material is not included in the chapter's Creative Commons license and your intended use is not permitted by statutory regulation or exceeds the permitted use, you will need to obtain permission directly from the copyright holder.





# Gender and Climate Change Adaptation Among Rural Households in Nigeria

# 103

Chukwuma Otum Ume, Patience Ifeyinwa Oyata, and  
Anthony Nwa Jesus Onyekuru

## Contents

Introduction .....	2100
Gender and Vulnerability .....	2102
Theoretical Framework .....	2104
Gender Schema Theory .....	2104
Institutional Theory .....	2104
Context of the Study .....	2105
Study Area .....	2105
Data Analysis .....	2105
Gender-Vulnerability Differential Among Smallholder Farmers in Nigeria .....	2107
Institutional Factors Undermining Climate Change Adaptation Among Female-Headed Households .....	2108
Land Tenure System .....	2109
Education and Awareness .....	2109
Access to Credit and Loan .....	2110
Overcoming the Barriers .....	2111

This chapter was previously published non-open access with exclusive rights reserved by the Publisher. It has been changed retrospectively to open access under a CC BY 4.0 license and the copyright holder is “The Author(s)”. For further details, please see the license information at the end of the chapter.

C. O. Ume (✉)

Agricultural and Environmental Policy Department, Justus Liebig University Giessen, Giessen, Germany

e-mail: [chukwuma.ume@agrar.uni-giessen.de](mailto:chukwuma.ume@agrar.uni-giessen.de)

P. I. Oyata

Department of Agricultural Economics, University of Nigeria, Nsukka, Nigeria

e-mail: [patience.opata@unn.edu.ng](mailto:patience.opata@unn.edu.ng)

A. N. J. Onyekuru

Resource and Environmental Policy Research Centre, Department of Agricultural Economics, University of Nigeria, Nsukka, Nigeria

e-mail: [anthony.onyekuru@unn.edu.ng](mailto:anthony.onyekuru@unn.edu.ng)

© The Author(s) 2021

W. Leal Filho et al. (eds.), *African Handbook of Climate Change Adaptation*,  
[https://doi.org/10.1007/978-3-030-45106-6\\_182](https://doi.org/10.1007/978-3-030-45106-6_182)

2099

Conclusion and Recommendation .....	2112
References .....	2113

---

### Abstract

Female- and male-headed rural households have unequal opportunities in climate change adaptation. Efforts in climate change adaptation in regions with deeply entrenched sociocultural norms should also account for the varied gender components of climate change. The broad objective of this study is to integrate gender issues into climate change adaptation thereby distilling lessons and evidence for policymakers on how to approach the necessary transformation of gender relations in climate change interventions. The study employed focus group discussions to uncover the structural factors undermining women's adaptive capacity, thereby making them vulnerable to climate change impacts. In addition to this, in-depth interviews were also conducted. For the in-depth interviews, 27 farmers were sampled using a snowballing method, while four focus groups were carried out differently for male and female farmers. Ten extension personnel and ten representations from the ministry of agriculture were also surveyed using in-depth interviews. Results from the study showed that female farmers in the region were more vulnerable to climate change as a result of the deeply rooted cultural systems and unwarranted assumptions about women. Findings also suggested that women with high adaptive capacity were less vulnerable to climate impacts. We conclude that gender-responsive climate change adaptation is important in achieving balanced relations that will ensure climate resilience in more equitable and nonhierarchical ways.

---

### Keywords

Vulnerability · Stereotypes · Gender mainstreaming · Qualitative methods · Socioeconomic status · Nigeria

---

## Introduction

Climate change is a global phenomenon undermining the efforts towards achieving the Sustainable Development Goals [SDGs]. The Intergovernmental Panel on Climate Change [IPCC] described climate change as the change in global climate patterns which can be identified by variabilities in climate properties over time (IPCC 2014). Climate change has become more threatening not only to environmental quality but also to the fight against poverty, disease, and hunger. This is due to its direct and indirect impacts on agricultural production. While efforts are being made in addressing the causes of climate change through mitigation, building adaptive capacity is particularly important as it will help tackle the current and future impacts of the phenomenon (IPCC 2007). The IPCC defines adaptation as the "adjustment in natural or human systems to a new or changing environment" (IPCC 2007). In other words, climate change adaptation deals with the ability of a system to

cushion possible impacts from climate change and to cope with the outcomes. The impact of climate change in the developing nations, according to Chukwuemeka et al. (2018), is mostly felt by the smallholder farmers, farmers that are highly dependent on rainwater and other climate-sensitive input and resources.

The vulnerability of these sets of farmers is expected to be even more severe in Nigeria, where majority of women folk are involved in agriculture for household consumption, yet are highly marginalized and excluded in climate decisions which directly affect them (Osuafor and Nnorom 2014). Gender relations in Nigerian agricultural sector have systematically subordinated women, limiting their access to adaptation information and supports (Uchem 2011). Chavez et al. (2011) describes gender as a social construct that portrays the distinction in roles and opportunities associated with the male and female sexes and the social relations between them. Studies on climate change adaptation by farmers in Nigeria have shown that gender relations and women exclusion in climate decisions adversely affect climate change adaptation efforts, as women contribute 60–80% of food production in the country, mostly for family consumption (Apata 2011; Tersoo 2013; Otitoju and Enete 2016). However, the underlying institutional factors behind these gender issues in Nigeria have not yet been clarified in literature. This gap in literature is what this study intends to fill. Paying attention to these relations is at the core of framing adaptation strategy that will allow farm households build resilience to the impact of climate change in agriculture (MacGregor 2010).

In Africa, literature in climate change adaptation have shown how smallholder farmers suffer high level of vulnerability due to their low adaptive capacity (Okon et al. 2010; Ume 2017). According to FAO (2019), “climate change impact first affects food systems and livelihood groups with a higher level of vulnerability.” The IPCC defined climate change vulnerability as the extent to systems, such as geophysical, socioeconomic, and biological systems, which are prone to and incapable of coping with adverse climate change impacts (IPCC 2007). Otitoju and Enete (2016) further noted that among the smallholder farmers in Nigeria, the female farmers are expected to have an even higher level of vulnerability compared to their male counterparts due to their lower adaptive capacities. This, according to them, is due to socioeconomic and institutional factors that undermine their adaptation efforts. According to Eakin and Wehbe (2009), gender transformation – a reassessment of the socioeconomic and institutional factors and relations – established over time, which determines the relationships between the men and women, is therefore imperative if meaningful adaptation effort is to be achieved.

Understanding the gender dimension of climate change adaptation and the underlying socioeconomic factors influencing gender-vulnerability relations among smallholder farmers in Nigeria presents a veritable approach in moving away from the usual incremental adaptation approach to transformational adaptation response. One key importance of transforming gender relations among smallholder farmers is that it is gender that determines the control and ownership of adaptation resources. As stated in FAO (2011), “If women had the same access to productive resources as men, they could increase yields on their farms by 20–30 percent.” Gender analysis

among smallholder farmers in Africa is necessary for unraveling how best to mainstream gender issues into climate change adaptation plans and policies.

The impact of gender relations on farmers' level of adaptation has been extensively reported in the literature. Findings from literature suggest that these gender issues vary from location to location according to levels of socioeconomic developments (Gafura 2017). As stated in Gafura (2017), these socioeconomic and institutional factors are still unsettled issues requiring further study in order to establish a coherent scholarship in the area.

As women make up the majority of the smallholder farm labor force in Africa, the available studies on climate change adaptation among smallholder farmers in Africa such as Komba and Muchapondwa (2015) have highlighted the need for studies that will link information and evidence of the underlying determinants of gender inequality from expert knowledge and farmer's perception, in order to better understand the factors that undermine efforts in coming up with formidable and gender-balanced adaptation policies. More so, the few available studies were based solely on quantitative analysis of household surveys without any qualitative component (Enete and Amusa 2010; Chukwumeka et al. 2018; Onyeneke et al. 2018). The implication is that since most of the underlying determinants of gender relations cannot be quantified, the results will lack the deep and contextual information needed for the appropriate policy interventions. This perhaps explains why studies on the gender dimensions of climate change adaptation among smallholder farmers in Nigeria have not been able to sufficiently identify and address the gender relations issues impeding climate change adaptation efforts in the country.

---

## Gender and Vulnerability

The etymology and usage of the word gender show that the concept and its meanings have evolved throughout history. The historical development dates to the late Middle English, when the word was first used to mean "sex of a human being" (Nancy 1989). Recently, it has been conceptualized as a social construct that appropriates certain characteristics such as behaviors, feelings, and attitudes to the male or female individuals in a society (Jrank 2018). What this means is, by knowing a person's gender, we place her or him in a separate social class, and somehow by doing that we judge her or his actions in accordance with our expectations of that social class. According to Jrank (2018), this categorization ultimately leads to the formation of a gendered society – a society with sociocultural expectations of actions deemed appropriate and inappropriate for females and males. This conceptualization led to the emerging theoretical framings on gender roles and stereotypes.

According to Caragliu et al. (2015), gender roles are socially and culturally defined prescriptions and beliefs about the behavior and emotions of men and women. Linda (2017) noted that it is common for different societies to have a set of belief, ideology, and orientation that shapes sociocultural stereotypes among individuals within that society. Caragliu et al. (2015) remarked that it is these gender roles and stereotypes that give rise to the issue of gender identity – a personal

perception of oneself which influences her or his status and relationship with other persons in the wider society. Linda (2017) argues that gender roles and stereotypes are determined by institutional factors such as rules, norms, and routines, and this consequently affect household interactions so that expectations from members of a household will be based on gender. Therefore, whereas it is traditionally acceptable for the men to have multiple streams of income, in countries like Nigeria, women, who are traditionally perceived as homemakers or housewives, due to stereotype threats, will only make do with farm produce and resources within the homes. According to Linda (2017), this stereotype threat arises as a result of the women's awareness that they are likely to be judged based on an overgeneralized societal belief about her gender roles.

Literature dealing with the influence of gender on vulnerability to climate change impacts follows three mutually exclusive criteria based on IPCC (2007) analysis. These three elements are: exposure (extent of susceptibility), sensitivity (degree of impact), and adaptive capacity (ability to adjust) to climate change impacts. The World Health Organization (2015) noted that female farmers in developing nations are more exposed to climate variabilities mostly because they make up greater percentage of the world's poor and are mostly charged with the responsibility of gathering firewood for heating and cooking, fetching water for domestic chores, and other activities directly linked to the environment. In terms of sensitivity to climate impacts, Mgbenka and Mbah (2016) noted that 80% of women in many African countries engage in agriculture and are more reliant for their means of support on natural resources that are vulnerable to climate change impacts. Expounding on this fact, Haque et al. (2012) recounted that more than 90% of the fatalities at the 1991 cyclone in Bangladesh were women, and this was due to their social status, limited skills set, and limited mobility. Finally, in assessing adaptive capacity of female-headed households, the RIO+ center in partnership with Food, Agriculture, and Natural Resources Policy Analysis Network conducted a survey in five southern African countries. The results of the survey showed a strong correlation between gender and adaptation level, with women more likely to have low levels of adaptation (Boko 2007). Further analysis showed that women and men in developing nations do not have equal access to climate change adaptation tools in agriculture, with men more likely to have higher access (Onwutuebe 2019). Other studies in various regions in Africa recorded similar results (MacGregor 2010; Ume 2018). Onwutuebe (2019) attributed these gender inequalities to the existing sociocultural norms and institutional factors that limit women's rights and control of resources such as land and financial services. However, none of such studies exploring the role of institutional factors in causing as well as transforming these gender differences have been conducted in Nigeria.

In Africa, studies have also shown that women are highly sidelined in climate decision-making processes, and this in turn affects their access to adaptation information and support in the country (Enete and Amusa 2010; Ume 2018). Enete and Amusa (2010) reviewed journal articles on the influence of socioeconomic characteristics on access to adaptation support in Nigeria in order to ascertain its impact on the agricultural sector of the economy and the implications for economic growth.

They noted, in line with RIO+ survey, that gender strongly influences access to support for climate change adaptation in agriculture in the country. Their work demonstrated the fact that although agriculture employs over 80% of the rural populace, Nigeria is the world's third most vulnerable country in terms of the impact of climate change in agriculture. Their main conclusion from the reviewed literature was that the adaptation differential between women and men undermines the capacity of the agricultural sector to absorb climate change multiple stressors and to maintain function in the face of climate change impacts. Similarly, Rammohan (2016) noted that women's lack of adequate access to adaptation support prevents the agricultural sector from evolving into more desirable configurations that build resilience.

---

## **Theoretical Framework**

### **Gender Schema Theory**

Gender schema theory as a perceptive theory attempts to explain the process involved in maintaining and transmitting gender-linked qualities from one generation to another, thereby creating gendered individuals in a community (Kendra 2020). Introduced by Sandra Bem in 1981, the theory shows that sex-linked information is mainly transmitted from one generation to another through "schemata," which is a systematic way of allowing some gender-associated information to be more imbibed by individuals within a society. This information consequently shapes the perception the society has about a particular gender in relation to the other gender, which eventually leads to gender stereotyping. The theory argues that the degree to which individuals become gender-stereotyped is influenced heavily by institutional factors and cultural transmissions such as norms, media, school, home training, etc. By institutional factors, the theory refers to configurations in the society that steers people's behavior (norms, routines, and rules). This means that changing any negative stereotype will involve a transformation of existing norms, rules, and routines.

### **Institutional Theory**

The institutional theory attempts to explain the process by which societal configurations or social structures (schemas, rules, norms, and routines) become enshrined as authoritative standards guiding social behavior in society (Dobbin and Vican 2015). The theory attempts to unravel how these structures are formed, accepted, and transmitted over time. Dobbin and Vican (2015) argued that these elements of a social structure (norms, rules, and routines) are perceptive and normative elements, that are enforced and endorsed by individuals and organizations which he referred to as "actors" and transmitted by relational systems at different scales and levels. Since they are imposed and upheld by people, they can be altered by affecting changes in



the social structures (Dobbin and Vican 2015). The theory suggests that through socialization, better and appropriate institutional elements in the form of cognitive orientation can be passed on to individuals and organizations, and when it is adopted, it becomes a new pattern or normal behavior. Over time, these new behaviors become resilient and sediment such that individuals begin to act autonomously without recognizing that they are being controlled by the institution.

---

## Context of the Study

### Study Area

The study area is Enugu State, Nigeria, that is located in the southeast geopolitical zone of Nigeria. The state was purposively selected because (a) the state is regarded as the capital and policy-making seat of the southeast geopolitical zone, (b) majority of the rural dwellers in this state engaged in small-scale farming, and (c) the state is reported to have experienced marginalization of women in climate change adaptation decision-making (Chukwuemeka et al. 2018). In the national census of 2006, the state has a population of about 3,267,837 (National Bureau of Statistics 2020). Based on the similarities in soil characteristics and by extension meteorological properties, Enugu State is divided into three agricultural zones [AZs]. The zones include Enugu zone, Nsukka zone, and Awgu zone (Fig. 1). The state is in a tropical rain forest zone, with a mean daily temperature of 27 °C and monthly rainfall of 18 mm to uncover the structural factors undermining women adaptive capacity, thereby making them vulnerable to climate change impacts.

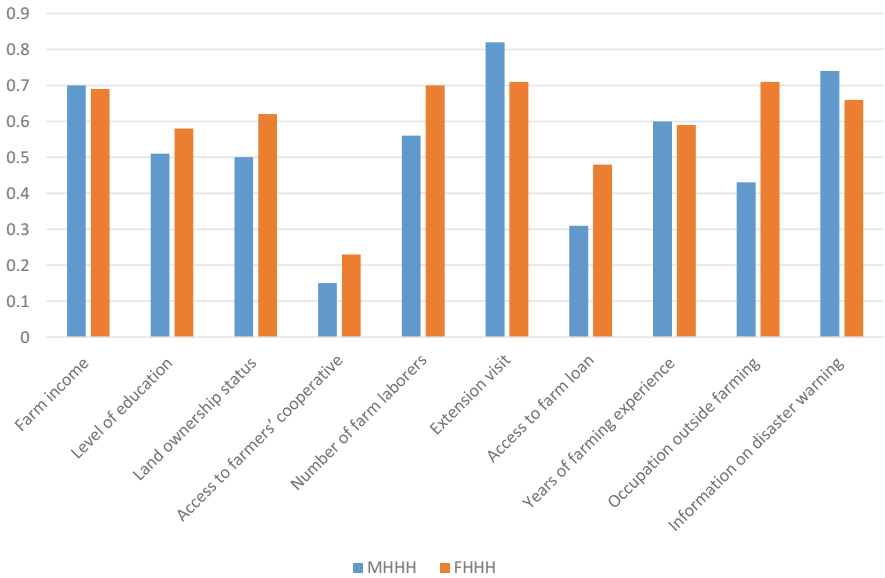
### Data Analysis

Two sets of qualitative data were generated using in-depth interviews and focus groups. Vulnerability analysis technique was employed to analyze the data generated from the interviews, while content analysis was employed to analyze the data generated from the focus groups.

Following Enete and Amusa (2010), we employed the adaptive capacity approach of the vulnerability index analysis to estimate and compare the vulnerability differential between male- and female-headed households in Enugu State, Nigeria. The justification for adopting this approach is based on the assumption that an increasing adaptive capacity (potential adaptation) will lead to a reduction in vulnerability (Enete and Amusa 2010). The measurement of the adaptive capacity of farm households was determined using sets of variables (vulnerability indicators). Results of this analysis are presented in Fig. 2. The variables that formed the adaptive capacity indicators include:

- Income level (farm income)
- Number of extension visit in the last cropping season

**Fig. 1** Map of Enugu State showing the three agricultural zones. (Sources: Chukwuemeka et al. (2018))



**Fig. 2** Gender-vulnerability differential among smallholder farmers in Nigeria

- Educational level
- Land ownership status
- Years of farming experience
- Membership of cooperative societies
- Number of employees in the farm
- Access to farm loan
- Off-farm activities
- Access to mass media and information on disaster warning

To determine the final index, each of the indicators was normalized so that they will be free from their respective units and lie between  $\min = 0$  and  $\max = 1$ . Equal weightage values were assigned to each variable and the average was taken as the value for the vulnerability index. We adopted the United Nations Development Programme method of normalizing life expectancy variables in the Human Development Index calculation (UNDP 2007). The normalization was carried out following Hahn et al. (2009) and Tewari and Bhowmick (2014) using the formula:

$$NS_v = \frac{S_v - S_{\min}}{S_{\max} - S_{\min}}$$

where:

$S_v$  = value of the component

$NS_v$  = normalized value for the component

$S_{\max}$  and  $S_{\min}$  = the maximum and the minimum possible values, respectively

By calculating the simple mean of all the variables, the vulnerability index (VI) of all the respondents for the female-headed and male-headed households was determined. To determine the vulnerability index for each gender, we went forward to calculate the mean of the VI for the female-headed households and the male-headed households separately.

The underlining explanation of the gender dimensions in climate change adaptation in Africa can be explained by considering two important theories: gender schema theory and the institutional theory.

---

## Gender-Vulnerability Differential Among Smallholder Farmers in Nigeria

Using years of farming experience as an indicator of adaptive capacity, the average vulnerability index showed that male-headed households (0.60) are more vulnerable compared to female-headed households (0.59). A discussion with the women in the communities showed that women are inducted into the farming occupation quite at an early age compared to their male counterparts. More farming experience suggests that women are better suited to acquire on-farm experience that will enable them

autonomously adapt to climate change impacts. For instance, unlike the male farmers, most of the female farmers engaged with could identify several changes in weather patterns they have noticed over the years and how they were able to overcome them. For instance, one of the women stated: “When I was still a youth, working on my mother’s farm, we hardly water out maize farms, but now, in order to get a good harvest and fresh grains we do water two or three times in a planting season.”

Turning now to off-farm income, female-headed households were found to have a higher vulnerability score. This means that more of the female-headed households rely only on farming for income. We observed that more than half of male-headed households (60%) in the study area reported some off-farming activities such as carpentry, palm wine tapping, and material recycling. The high agriculture dependency index of female-headed households (0.71) suggests that the female-headed households might be very sensitive to climate change impacts, as agriculture, being a very volatile and unpredictable enterprise, is subject to total loss once there is a climate event such as flooding, heatwave, or even disease outbreak. Encouraging the women to engage in off-farm activities, therefore, presents a very good way of reducing their vulnerability.

Both the female- and male-headed households had almost the same VI when information on disasters warning is used as an adaptive indicator (Fig. 2). Information gathered from the Agricultural Development Program (ADP) agents indicated that most of the information on disaster warning is normally conveyed through radio stations. Therefore, only women farmers who have radio sets and are close to radio stations, which are mostly located at Enugu zone, can receive information on disaster warnings and weather forecasts.

In general, when all the vulnerability scores were averaged, findings from the analysis, using the adaptive capacity approach, showed that female-headed households in Enugu State, Nigeria, has lower adaptive capacity than their male-headed households. This finding was in line with previous studies such as Amusa (2010). However, we observed a relatively lower vulnerability gap between female- and male-headed households compared to studies such as Amusa (2010). Studies such as Amusa (2010) used the same variables and adaptive capacity indicators employed in this study and reported (female-headed households = 0.73 and male-headed households = 0.43); however, in this study, we estimated a vulnerability index for the female-headed households = 0.61 and male-headed households = 0.55. However, the variation in result reported can be as a result of variation in study area and time when the studies were conducted. The next section attempts to uncover the institutional factors that influence this gender-vulnerability differential.

---

## **Institutional Factors Undermining Climate Change Adaptation Among Female-Headed Households**

Most policies and norms that are structured to tackle women’s adaptation needs do not address the bigger gender issues. Consistent with the institutional theory, beliefs within the societies have become enshrined as authoritative standards underpinning

social justice behavior in the society, irrespective of the negative consequences it carries with it. Some of the cultural practices that need to be transformed are discussed below.

### **Land Tenure System**

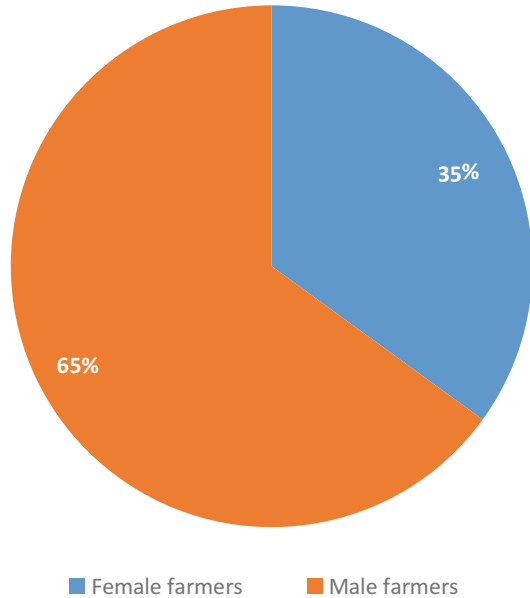
This includes the issues of land ownership and transference. From our focus group discussions with the farmers, it was observed that the people hold the belief that if a man dies and he has female and male children, that only the males have the right, by tradition, to possess the family lands. As one of the female farmers stated: *“this 3-story building you are seeing belongs to my brother and the well here for irrigation is also his, these are what he built from his ‘Nsukka pepper’ farm which is five times the size of mine, and I must pay rent for my own little piece of land.”* This is because the culture does not permit women to inherit land, they will resort to renting or saving huge sums to purchase their own lands. Scholars in the domain of land reform claim that the main obstacle to climate change adaptation in terms of climate-smart agricultural practices like land rotation, fallowing, etc. is shortage of land and population pressure. However, evidence from our study so far showed that it is not really the shortage of land alone, which affects the adoption of adaptation measures but the structure of land tenure.

Greater population of the farmers in the rural areas are females, but the lack of proper land ownership shifts land title and hence access to the male. Female farmers with both structural and relational access to land have better control and decision on how to put the land to best use. This is predominantly the major problem particularly in most sub-Saharan African countries including Nigeria. The issue of land tenure system, land rights, and climate change adaptation, therefore, presents a very important area that needs to be transformed for better adaptation. Although a strategic gender-responsive and socially inclusive approach can foster a balanced representation of men and women in adaptation initiatives, climate change gender dimensions, and priority to include and empower women and men equally (e.g., by giving them a voice in structural and relations access to land) remain low. Climate change adaptation efforts rest critically on the aspirations and support of those who depend on land-based livelihoods – whose rights and access to land must be protected and promoted for climate change adaptation efforts and initiatives to be sustainable.

### **Education and Awareness**

Similarly, it was observed that it is normal for parents to send their male children to school instead of their female children. The male farmers interviewed were of the opinion that “the females are ‘liabilities’ but the males are ‘assets’”. According to one of the male farmers, *“training my female child in school only for her to get married to another man doesn’t benefit me.”* This shows the level of unjustified assumption about women. Some of these are the assumptions that women farmers

**Fig. 3** Channel of extension visits to households



are less informed or intelligent; that some activities are not supposed to be taken up by women; and that women farmers have low self-confidence in taking certain farming decisions. Consistent with the gender-schema theory, these assumptions have been transmitted from one generation to another and have shaped the perception the society has about the female farmers. For instance, it was gathered that extension agents prefer explaining techniques to the male farmers, as they feel they are smarter than their wives, so they can pass the information to their wives. Even the females who oversee the family farms will always project their husband as the household heads, to be better positioned to receive extension services and government aids more easily.

Our study investigated the number of times extension agents visit the female farmers, or gave direct demonstrations to the female farmers, given that extension visits and service delivery helps encourage adaptation. We found that majority of the times (65%), most of the contacts were to the male household heads, though the actual farmers are the wives (Fig. 3).

Several studies (Amusa 2010; Apata 2011; Emeana et al. 2018) have shown the positive influence of direct contact in adoption of climate-smart agricultural practices such as zero tillage (Emeana et al. 2018), organic farming (Apata 2011), and increased soil water conservation practices (Amusa 2010).

### **Access to Credit and Loan**

The result of our analysis revealed that women who have access to credit and loan facilities had a higher possibility of adaptation to climate change. This is in line

with the general literature on credit and small-scale farming in the developing nations. According to Otitoju and Enete (2016), access to credits increases farmers coping capacities and access to more adaptation technologies. Similarly, farm size is as important as capital, and the coefficient of farm size was found to be a statistically significant positive determinant of adaptation. This means that females with larger farm sizes have a higher possibility of adapting (Amusa 2010; Enete and Amusa 2010; Chukwuemeka et al. 2018). This also corroborates the economic constraint paradigm which argues that economic constraints and resource endowments are the key determinants of adoption decision such that lack of access to capital or land could significantly constrain both adoption decisions and extent of adoption (Raihan et al. 2009; Zetterlund 2013).

Literature on micro-financing for smallholder farmers shows that microcredit facilities play a huge role in increasing the level of adoption of climate change adaptation technologies and sustainable land-use practices. Emerging theme from our focus groups shows that there exist functional credit schemes, known as “*Akawo Scheme*” in the area that supports the farmers with soft loans. Majority of the farmers explained that the scheme offered them loans from which they were able to support themselves in times of crop failures and even to purchase inputs that they will require in their farms. However, we observed that most of the individuals who did not have access to such networks were females. The female farmers explained that because their husbands are members, they are not allowed to take part as well. Most times, the males are not the farmers, so the loans they get are used for other things but aiding their wives on the farm.

---

## Overcoming the Barriers

We observed two main manners to counter the gender barriers that we illustrated above. First is to improve gender competence and gender training. This means the ability to recognize the social construction and reproduction of gender roles and transform the discriminatory structures and processes. Understanding the gender identities and relations in society will help see the framework conditions provided for women and men, only then can we easily change the perspectives.

Climate change adaptation professionals might be aware of the assessment tools and adaptation strategies; however, they also need to be aware of how they can integrate gender into these strategies and tools in order to acquire gender competence. These can be done in two ways: first is to ensure training on gender and for women. Professionals should be taught on the impact of gender negligence on projects and policy outcomes. Awareness should be raised on how adaptation policies affect men and women differently, making professionals aware of these will have both immediate and long-term impacts. The second is to involve gender experts and specialists that can develop gender-sensitive political measures. They will be able to dictate gender lapses in advance and suggest which areas to pay closer attention to.

The second way is to ensure a bottom-top approach to climate change and gender mainstreaming. One important observation is that the women have indigenous

adaptation strategies and are in tune with their environment. They adopt autonomously and can provide strategies that are very beneficial for them. However, adaptation policies are often designed through top-down and bureaucratic models. This has two adverse consequences. The first consequence is that the strategies offered to appear as an imposition of external views and knowledge, and thus appear as unnecessary burden to the female farmers, who are supposed to benefit from them. If the females are engaged in policymaking and are allowed to contribute their knowledge, it would certainly lessen the skepticism and opposition toward adaptation. This will make the policies to focus more on inciting and convincing individuals to autonomously integrate climate impacts prevision in their everyday business. The second consequence of the top-bottom approach is that the male counterparts find it easier to receive the knowledge and adaptation technologies when it eventually drops down to the bottom. If the role of adaptation policy is to reduce vulnerability to climate change through the present modification of the behavior of affected actors so that they integrate and anticipate future impacts of climate change, then it is far from an easy task when the women are engaged actively and at all level in conceiving, planning, and executing climate change adaptation policies.

---

## Conclusion and Recommendation

A gendered perspective on climate change adaptation efforts among smallholder farmers is crucial to sustainable development. This study has added more evidence to the literature on gender and climate change adaptation. Although there appears to be a narrowing of the gender vulnerability gap among smallholder farmers in the area, evidence from this study shows that much work still needs to be done in addressing gender issues in climate change adaptation in Africa, including Nigeria. By taking a gender-sensitive approach, this study highlighted the determinants of adaptation among female-headed households in Nigeria and factors that influence their adaptation to climate change impacts. Furthermore, by incorporating context-specific evidence from the rural farmers, the underlying gender relations and cultural orientations undermining the adaptive capacity of female-headed households were explored. Transforming these gender relations and cultures must form the bedrock for building resilience among farm households in the area. The result of this study shows that cultural systems, policies and practices, and unwarranted assumptions about women are gender relations issues that undermine efforts in building climate change resilience among female-headed households.

Based on the findings from this study, shelving of the identified belief systems that hamper the adaptive capacities of females in the area should be encouraged. It has become obvious that with such societal configurations on the ground, adaptation efforts might be jeopardized. In line with the interactionist theory of gender, since gender relations issues are produced by people through interaction, through a deliberate effort by the people, the unwarranted assumption about women and the enshrined belief systems can also be changed.



## References

- Amusa TA (2010) Gender and farm household decision on climate change adaptation in southeast, Nigeria. University of Nigeria
- Apata TG (2011) Factors influencing the perception and choice of adaptation measures to climate change among farmers in Nigeria. Evidence from farm households in Southwest Nigeria. Available at: [https://businessperspectives.org/images/pdf/applications/publishing/templates/article/assets/4402/ee\\_2011\\_04\\_Apata.pdf](https://businessperspectives.org/images/pdf/applications/publishing/templates/article/assets/4402/ee_2011_04_Apata.pdf). Accessed 23 Apr 2020
- Boko M (2007) Executive summary Chapter 9: Africa. In: Parry ML et al (eds) *Climate change 2007: impacts*. London/Cambridge, UK: Cambridge University Press. Print version
- Caragliu A et al (2015) Smart cities: transformación digital de las ciudades. In: *International encyclopedia of the social & behavioral sciences*, 2nd ed, pp 113–117. <https://doi.org/10.1016/B978-0-08-097086-8.74017-7>
- Chavez PR et al (2011) Impact of a new gender-specific definition for binge drinking on prevalence estimates for women. *Am J Prevent Med* 40(4):468–471. <https://doi.org/10.1016/j.amepre.2010.12.008>
- Chukwuemeka SU, Alaezi K, Ume C (2018) Climate change vulnerability analysis of smallholder farmers in Enugu state Nigeria: gender sensitive approach. *J Aridland Agric* 4(1):1–6. <https://doi.org/10.25081/jaa.2018.v4.3374>
- Dobbin F, Vican S (2015) Organizations and culture. In: *International encyclopedia of the social & behavioral sciences*, 2nd ed. Elsevier, pp 390–396. <https://doi.org/10.1016/B978-0-08-097086-8.10453-2>
- Eakin HC, Wehbe MB (2009) Linking local vulnerability to system sustainability in a resilience framework: two cases from Latin America. *Clim Change* 355–377. <https://doi.org/10.1007/s10584-008-9514-x>
- Emeana E, Trenchard L, Dehnen-Schmutz K, Shaikh S (2018) Evaluating the role of public agricultural extension and advisory services in promoting agro-ecology transition in Southeast Nigeria. *Agroecol Sustain Food Syst* 43(2):123–144. <https://doi.org/10.1080/21683565.2018.1509410>
- Enete A, Amusa T (2010) Challenges of agricultural adaptation to climate change in Nigeria: a synthesis from the literature. *Field Actions Sci Rep* 4:1–6. <https://journals.openedition.org/factsreports/678>
- FAO (2011) *The state of Food and Agriculture 2010–11*. Food and Agriculture Organization of the United Nations, Food and Agriculture Organization. Available at <http://www.fao.org/publications/sofa/2010-11/en/>. Accessed 23 Apr 2020
- FAO (2019) *Climate change*. Food and Agriculture Organization of the United Nations. Available at: <http://www.fao.org/climate-change/en/>. Accessed 23 Apr 2020
- Gafura AG (2017) Land grabbing, agrarian change and gendered power relations: the case of rural Maasai women of Lepurko village, Northern Tanzania
- Hahn MB, Riederer AM, Foster SO (2009) Climate change and human health literature portal the livelihood vulnerability index: a pragmatic approach to assessing risks from climate variability and change – a case study in Mozambique. *Glob Environ Change* 19(1):74–88. <https://doi.org/10.1016/j.gloenvcha.2008.11.002>
- Haque U et al (2012) Reduced death rates from cyclones in Bangladesh. *Bull World Health Organ* 90(2):150–156. <https://doi.org/10.2471/BLT.11.088302>
- IPCC (2007) Annex B. Glossary of terms. Intergovernmental Panel on Climate Change. Available at: <https://archive.ipcc.ch/pdf/glossary/en.pdf>. Accessed 22 Apr 2020
- IPCC (2014) *Who is who in the Intergovernmental panel on climate change*. World Meteorological Organization Building, Switzerland
- Jrank (2018) Sex roles – sex-role stereotypes, sex-role socialization – attitudes and behavior, emotional development, Lawrence Kohlberg, and considered – JRank articles. Available at: <https://psychology.jrank.org/pages/575/Sex-Roles.html>. Accessed 23 Apr 2020
- Kendra C (2020) Gender schema theory and roles in culture. Available at <https://www.verywellmind.com/what-is-gender-schema-theory-2795205>. Accessed 23 Apr 2020

- Komba C, Muchapondwa E (2015) Adaptation to climate change by smallholder farmers in Tanzania. Environment for Development Initiative. Available at <http://www.jstor.org/stable/resrep15022>
- Linda L (2017) Gender roles: a sociological perspective – Linda L Lindsey. Google Books. Available at [https://books.google.de/books?hl=en&lr=&id=qjjbCgAAQBAJ&oi=fnd&pg=PP1&dpRF1\\_Sxf93pCuL46fbuqUdbA\\_4&redir\\_esc=y#v=onepage&q=genderroles&f=false](https://books.google.de/books?hl=en&lr=&id=qjjbCgAAQBAJ&oi=fnd&pg=PP1&dpRF1_Sxf93pCuL46fbuqUdbA_4&redir_esc=y#v=onepage&q=genderroles&f=false). Accessed 23 Apr 2020
- MacGregor S (2010) “Gender and climate change”: from impacts to discourses. *J Indian Ocean Reg* 6(2):223–238. <https://doi.org/10.1080/19480881.2010.536669>
- Mgbenka RN, Mbah EN (2016) A review of smallholder farming in Nigeria: need for transformation. *Int J Agric Ext Rural Dev Stud* 3(2):43–54. Available at <http://www.eajournals.org/wp-content/uploads/A-Review-of-Smallholder-Farming-In-Nigeria.pdf>
- Nancy C (1989) *Feminism and psychoanalytic theory* by Nancy Chodorow. Amazon.com: Books. Available at: <https://www.amazon.com/Feminism-Psychoanalytic-Theory-Chodorow>. Accessed 23 Apr 2020
- National Bureau of Statistics (2020) Pverty statistics. Available at: [https://nigerianstat.gov.ng/elibrary?queries\[search\]=poverty](https://nigerianstat.gov.ng/elibrary?queries[search]=poverty). Accessed 23 Feb 2020
- Okon U, Enete A, Bassey N (2010) Technical efficiency and its determinants in garden egg (*Solanum spp*) production in Uyo Metropolis, Akwa Ibom State. *Field actions science reports. J Field Actions* 1(1). Available at: <https://journals.openedition.org/factsreports/458>
- Onwutuebe CJ (2019) Patriarchy and women vulnerability to adverse climate change in Nigeria. *SAGE Open*. 9(1):215824401982591. <https://doi.org/10.1177/2158244019825914>
- Onyeneke RU et al (2018) Status of climate-smart agriculture in Southeast Nigeria. *GeoJournal* 83 (2):333–346. <https://doi.org/10.1007/s10708-017-9773-z>
- Osuafor A, Nnorom N (2014) Impact of climate change on food security in Nigeria. *Affrev Stech* 3:208–219
- Otitoju MA, Enete AA (2016) Climate change adaptation: uncovering constraints to the use of adaptation strategies among food crop farmers in South-west, Nigeria using principal component analysis (PCA). In: Tejada Moral M (ed) *Cogent food & agriculture*, vol 2(1). Informa UK Limited. <https://doi.org/10.1080/23311932.2016.1178692>
- Raihan S, Fatehin S, Haque I (2009) Access to land and other natural resources by the rural poor: the case of Bangladesh. MPRA paper. University Library of Munich, Munich
- Rammohan A (2016) Food and nutrition security within the household: gender and access. In: *Routledge handbook of food and nutrition security* (pp. 368–378). Routledge
- Tersoo P (2013) Agribusiness as a veritable tool for rural development in Nigeria. *Mediterr J Soc Sci* 4(8):17. Available at: <https://www.mcser.org/journal/index.php/mjss/article/view/1755>
- Tewari HR, Bhowmick PK (2014) Livelihood vulnerability index analysis: an approach to study vulnerability in the context of Bihar. *J Disaster Risk Stud*, 6(1):1–13. Available at: <https://journals.co.za/content/jemba/6/1/EJC163446>
- Uchem R (2011) Gender roles of men and women in Nigeria and in the United Kingdom. <https://doi.org/10.13140/RG.2.1.2611.3527>
- Ume C (2017) Critical perspective on climate change adaptation among farmers in developing nations: unpacking divergent approaches. *Mod Concepts Dev Agron* 1(1). <https://doi.org/10.31031/mcda.2017.01.000504>
- Ume C (2018) Critical perspective on climate change adaptation among farmers in developing nations: unpacking divergent approaches. *Modern Concepts & Developments in Agronomy I* (1):1–6. <https://doi.org/10.31031/mcda.2017.01.000504>
- UNDP (2007) *Human Development Report 2007: Fighting climate change – Human solidarity in a divided world*. New York. <http://hdr.undp.org/en/content/humandevlopment-report-20078>
- World Health Organization (2015) *Gender, climate change and health*. World Health Organization. Available at: <https://www.who.int/globalchange.pdf>. Accessed 23 Apr 2020
- Zetterlund Y (2013) Gender and land grabbing – a post-colonial feminist discussion about the consequences of land grabbing in Rift Valley Kenya. Available at: <http://dspace.mah.se/dspace/handle/2043/15718>

**Open Access** This chapter is licensed under the terms of the Creative Commons Attribution 4.0 International License (<http://creativecommons.org/licenses/by/4.0/>), which permits use, sharing, adaptation, distribution and reproduction in any medium or format, as long as you give appropriate credit to the original author(s) and the source, provide a link to the Creative Commons license and indicate if changes were made.

The images or other third party material in this chapter are included in the chapter's Creative Commons license, unless indicated otherwise in a credit line to the material. If material is not included in the chapter's Creative Commons license and your intended use is not permitted by statutory regulation or exceeds the permitted use, you will need to obtain permission directly from the copyright holder.





# Local Institutions, Collective Action, and Divergent Adaptation: Case from Agro-Pastoral Niger

# 104

Julie Snorek

## Contents

Introduction .....	2118
Institutions, Adaptive Capacity, and Divergent Adaptation .....	2118
Niger's Institutions Relevant to Divergent Adaptation .....	2120
Adaptation Without Mobility .....	2122
Multiple Sub-National Governance Arrangements .....	2125
Conflict in the North: The Agro-Pastoral Keita Department .....	2127
"Trapping" Livestock in Keita's Divergent Adaptation Arena .....	2131
Cooperation and Customary Chiefs: The Heavily Cultivated Madaoua Department .....	2133
Communication Promotes Collective Action in Madaoua's Divergent Adaptation Arena .....	2134
"Democracy as Problem"?	2136
Conclusion .....	2137
References .....	2139

## Abstract

Adaptation is a highly contextual process, framed by institutions. When one group's adaptation to climate hazards reduces another's adaptive capacity, this is called divergent adaptation. The nuances of divergent adaptation are revealed in how institutions influence divergent adaptation outcomes, either to exacerbate conflict or to bring about greater peace and cooperation. By examining the sometimes conflicting adaptations of pastoralists and agro-pastoralists in Niger,

This chapter was previously published non-open access with exclusive rights reserved by the Publisher. It has been changed retrospectively to open access under a CC BY 4.0 license and the copyright holder is "The Author(s)". For further details, please see the license information at the end of the chapter.

J. Snorek (✉)

United Nations University Institute for Environment and Human Security (UNU-EHS), UN Campus, Bonn, Germany

Dartmouth College, Hanover, NH, USA

this chapter describes the process of divergent adaptation through an institutional analysis from multiple scales. At the national scale, climate change adaptation policies and perspectives are entrenched in sedentarization politics vis-à-vis pastoral livelihoods. At the local scale, pastoralists take a defensive position as an adaptation pathway, to ensure secure passage with their livestock to water and pasture. However, in localities where local institutional actors have enhanced collective action arenas in which pastoral and agro-pastoral groups are represented, conflict dynamics are abated. Climate adaptation is not without conflict; however, local and sub-national institutions are critical to providing opportunities for collective action, cooperation, and peace in the context of divergent adaptation. Based on these findings, it is recommended that conflict and adaptation management and planning be integrated at multiple scales.

---

**Keywords**

Climate change · Divergent adaptation · Local institutions · Conflict · Cooperation · Collective action · Pastoralist · Niger

---

## Introduction

### Institutions, Adaptive Capacity, and Divergent Adaptation

Climate change impacts are contributing to human insecurity of complex, social ecological systems (SES) (Adger et al. 2014). These complex systems are sometimes able to enhance their resilience through adaptation (Gunderson and Holling 2002; Lebel et al. 2006; Adger et al. 2007). However, in other cases, adaptation devolves into maladaptation (Barnett and O'Neill 2010; Magnan et al. 2016) and/or divergent adaptation (Snorek et al. 2014a). Divergent adaptation is the process by which one group's adaptation to climate hazards reduces another's adaptive capacity and may result in coupled conflict-cooperation dynamics or exacerbate inequities (Hoque et al. 2018; Sovacool et al. 2015; Snorek et al. 2017; Sovacool 2018). Building adaptive capacity for *all* and avoiding divergent adaptation are related to institutions, which have been shown to have a direct influence on adaptive capacity (Olsson and Folke 2004; Adger et al. 2006; Hill 2013; Gupta et al. 2010; Berman and Paavola 2012). Institutions are the informal and formal rules, values, norms, and cognitive processes that constrain individual and collective behavior as well as access to resources and information (Dennett 2013).

Adaptive capacity is dependent upon the inherent and prescribed elements that make up institutions, including those that empower social actors to respond to short- and long-term impacts either through planned measures or through allowing and encouraging creative responses from society both *ex ante* and *ex post* a hazard event (Gupta et al. 2010). By enabling or denying a user or groups' ability to obtain entitlements, access resources, and garner information necessary to their adaptive capacity, institutions, thus, create the conditions for or *frame* divergent adaptation

(Snorek et al. 2017; Adger and Kelly 1999; Berman and Paavola 2012). While some paradigms for adaptation and disaster risk management are dominated by top-down hierarchical approaches (Allen et al. 2010), the institutions that empower stakeholders to participate and make decisions to support adaptation demonstrate bottom-up, equitable, and democratic processes (Cleaver 2002; Olsson and Folke 2004; Ostrom 1999; Engle and Lemos 2010; Eriksen et al. 2011). Understanding how institutions foster cooperation through divergent adaptations has implications for the development of institutions (Gupta et al. 2010; Adger 2001; Ostrom 2005). In light of increasing human insecurities and the prevalence of divergent adaptation (Snorek et al. 2014, 2017), it has become critical to understand *how* institutions are shaping adaptive capacity, *for whom* (Adger et al. 2014; Magnan et al. 2016; Eriksen et al. 2011; Ruiz-Mallén et al. 2015), and with *what consequences* (Snorek et al. 2014a, 2017).

This chapter highlights these questions by examining farmer (agro-pastoral – sedentary pastoralism mixed with cultivation) and herder (pastoral) conflict in Niger (Snorek et al. 2014a). Pastoral and agro-pastoral societies typically live in marginal lands, which are vulnerable to the impacts of climate change such as rainfall variability (Adger et al. 2014; Snorek et al. 2012; Herrero et al. 2016) and also have been shown to be highly adaptable. It has been found (Snorek et al. 2014a) that when pastoralists and farmers engage in conflict, these are not caused by drought conditions and resulting adaptations directly, but rather by the institutional and structural conditions shaping adaptation. As Sovacool et al. (2015; 2018) and Snorek et al. (2017) highlight, the conditions leading to divergent adaptation include land tenure shifts from common to private property regimes or enclosures, the marginalization and exclusion of “the other” (defined here as the individual or communities not involved in the said adaptation efforts), encroachments from actors or groups that imperil the healthy functioning of a commonly shared resource (e.g., visiting herders not aware of grazing practices prompting degraded pastures), or the entrenchment of an institutional system in which social inequalities are permitted to pervade (e.g., laws that support agro-pastoralism and usurp pastoral livelihood needs). In turn, these institutional dynamics shape divergent adaptation and lead to conflict dynamics including land alienation, access refusals or exclusion, political marginalization, and violent instability (Snorek et al. 2014a; Alemu 2018).

Niger’s rainfall (average 150–500 mm per annum) and climatic conditions (Bruggeman et al. 2010) are highly suited for dryland-adapted, pastoral, and agro-pastoral livelihoods (Mortimore 1989; Niamir-Fuller 1998). Reflecting this, more than 20% of Niger’s export earnings are generated by livestock, produced upon rangelands and through transhumant pastoralism (Zakara and Abarchi 2007). Farming or agro-pastoralism is considered to be the principal rural activity (Lund 1998). The country’s population grows at rates of 4% per annum (World Bank Data 2016), for which the majority subsists on rain-fed agro-pastoral activities. There is a high level of confidence that Niger’s Tahoua Region will experience an increase in temperature by 2 °C by 2050 and a slightly less confident prediction of an overall increase in annual rainfall (+7%) with decreasing rainfall during the typical rainy season (–4 and – 6%, respectively) (Bruggeman et al. 2010). These data, along with

other reports on rainfall projections for the Sahel (Biasutti et al. 2008; Shanahan 2009), point to increasing rainfall variability as a result of climate change, which has consequences for institutions relevant to divergent adaptation (Snorek et al. 2014a).

The country's adaptive capacity, which is among the lowest in the world (Vincent 2007), is exacerbated by chronic poverty (55% of rural population), widespread illiteracy (84% of those older than 15), and frequent droughts that devastate the rural economy (IFAD 2016). High levels of rainfall variability coupled with overgrazing, poor soil management, the enclosure of land and water resources (Snorek et al. 2017), precarious pasture spatial and temporal availability (Bode 2011), and decreasing agricultural production yields (Snorek et al. 2014a) result in degradation feedback loops, which further impact the local-scale climate system.

Understanding how divergent adaptation, pastoral-agro-pastoral conflict, and institutional processes play out in Niger is important to developing adaptation policies that reduce the prevalence of divergent adaptation. Institutions governing adaptation must seek out the ways that they are producing divergent adaptations, understand which actors in a social ecological system are the "winners," and create systems to lessen the consequences for the "losers." The following chapter highlights how these processes take place through a case study. The aims of this chapter is to specifically examine how more adaptive and inclusive institutional models relate to divergent adaptation processes and if they might bring about more sustainable, peaceful modes of adaptation (Magnan et al. 2016; Eriksen et al. 2011) for groups facing livelihood insecurities, social and climate vulnerability, and marginalization.

## **Niger's Institutions Relevant to Divergent Adaptation**

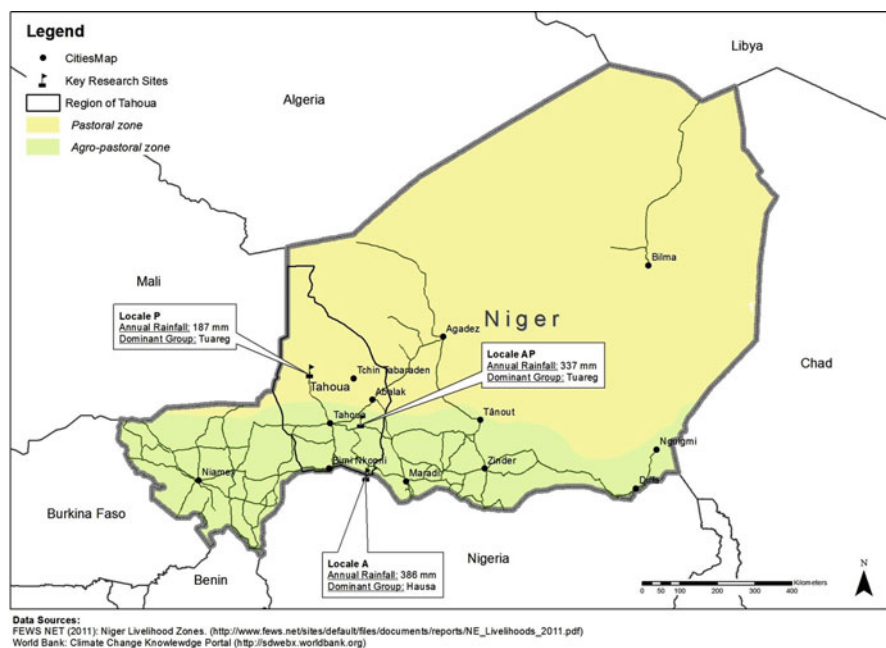
National legislation relevant to climate change and adaptation provides an overarching framework for how adaptation functions as a process. In the Nigerien context, the implementation of national legislation is filtered through multiple layers of decentralization. For the most part, very few lower-tier institutions in Niger understand specific elements of the Rural Code (Lund 1998; Benjaminsen et al. 2009; Snorek et al. 2011). At the sub-national scale, it is the members of the commissions foncières (COFOs) or land commissions, court officials, administrators, and experts from governmental and nongovernmental associations that support processes of implementation of this legislation through multiple methods and means. While documentation of infractions is scarce, *Procès Verbaux* (PVs) represent the main legal documents filed for litigation related to land and water access and use and cattle theft at the time of data collection (2011). A thorough review of PVs provides deep insight into how legislation is being implemented and what conflicts are occurring.

The sparseness of documentation in Niger, however, translates to only a fragmented understanding of conflict resolution mechanisms. In turn, most conflict is resolved outside of the formal system through the canton and group (customary) leadership. These institutions reside at the local scale, where they have perhaps a strong influence on the adaptive capacity of pastoralist and agro-pastoralists in the

country (Kpadonou et al. 2012). Customary chiefs represent both the traditionally pastoral (Fulani and KelGeres and Ouilimiden Tuareg) and traditionally agricultural (Hausa) groups. The pastoral counterparts of these local-scale institutional actors (group chiefs) are often on the move to visit their mobile constituents, scattered across the region. Often, group chiefs travel to places where they might influence decision-making processes in the village sites, along pastoral corridors, and in the camps of more affluent pastoralists.

In the water-stressed, administrative region of Tahoua, Niger, one finds large transhumant livestock herds migrating along the North-South axis between Nigeria and Niger's pastoral zone (Fig. 1), villages and nomadic camps empty of young male residents during the dry season due to high rural-to-urban migration, and a chronic dependence on drought relief due to frequent dry spells. In Tahoua, conflict breaks out most often along in vulnerable areas where pastoral corridors snake through croplands. As a result, local agriculturalists plant in pastoral resting areas to "herd" livestock elsewhere and away from croplands. Security in this region is tenuous not only due to a lack of infrastructure and policing but also due to the growing presence of clandestine and sometimes jihadist activities.

Tahoua, in turn, represents a North-South, low to high rainfall gradient that consists of the northern pastoral zone, the southern agro-pastoral zone, and the high cash crop production areas (Fig. 1). Residents in Locale P are majority pastoral households, a region receiving 187 mm rainfall per annum and possessing common



**Fig. 1** Map depicting the Tahoua Region – a thin, black outline – and the three locales (Locale P or pastoral, Locale AP or agro-pastoral, and Locale A or agricultural)



pastoral areas, governed by local customs. Locale AP is populated by a majority of agro-pastoral households and receives 337 mm per annum. In Locale A, the majority takes part in multiple agricultural activities including dry and irrigated cultivation and also some localized and mobile livestock production, receiving 386 mm of rainfall per annum (Fig. 1).

There is high institutional diversity across the different scales and localities, resulting in variable levels of adaptive capacities between users. Cultural groups include both traditional sedentary and nomadic groups from the Hausa, Fulani, KelGeres Tuareg, and Ouillimiden Tuareg at both the local and sub-national scales. Users were aggregated by their activities and status as a local (strong place connection) or nonlocal to the zone – local pastoralists (seminomadic, livestock as their primary capital), local agro-pastoralists (sedentary, land and livestock as capital), and nonlocal, visiting pastoralists (mobile, sometimes serving as shepherds).

According to 43 pastoral and 34 sedentary households as well as customary, administrative, and technical leaders, there are three key conflict-triggering events in this region of Niger: the spreading of cultivated fields (also an adaptation), crop damage (a response to adaptation), and livestock theft (a response to adaptation). Conflict is related to hydro-climate hazards, the ways in which groups control access to resources like water, pasture, croplands, the mode of common pool resource management, and historical institutional arrangements such as placing boundary markers for a pastoral corridor or declaring a certain plateau for pastoral purposes. These multiple dynamics are key to understanding the relationship between institutions and divergent adaptations.

## **Adaptation Without Mobility**

In 2011, a group of multiple experts on pastoralism and agro-pastoralism in Niger came to a consensus that in light of future scenarios of climate change for the country, mobile pastoralists would eventually cede to a sedentary, agro-pastoral livelihood. The main element contributing to this determination was the rapid transition of pastoral commons to semiprivatized, cultivated land, even within the northern, official pastoral zone (Snorek et al. 2017). What fuels this transition are an utter lack of political will to support pastoral livelihoods and multiple institutional arrangements supportive of sedentarization (Snorek et al. 2012). An unwritten but widely shared *de facto* policy that “land belongs to the cultivator” originated in the Former President Kuncé’s post-drought radio address to the nation and was meant as a way to lift up the peasant and give him/her land rights and food security. This movement shifting a pastoral nation to a sedentary farming landbase has roots in the precolonial and colonial frameworks, which shaped the modern national and sub-national institutions in Niger and, in turn, have framed how entitlements to common land and water are distributed at the local scale. These policies, while not specifically titled “adaptation policies” in word, were enacted in response to the key climate change impact on the Sahel – drought.

In 1961, as Nigeriens watched the high rainfall periods of the 1950s fall in a downward spiral of rainfall deficit years, the fledgling Nigerian government

established Law N°61–05, which effectively divided the country into two sections. Supporting the burgeoning southern populations with new land tenure, the far northerly edge of the Sahara was designated for pastoralism, while new parts of his “new” South were earmarked for cultivation (Fig. 1). This was heralded as an effort to strengthen the pastoral system; however, this demarcation served, rather, to enclose the pastoral population and restrict their mobility while concurrently expanding cultivation. Concurrently, due to disputes about the exact location of this zone, cultivation continues to creep northward with impunity.

In the years following the two great Sahelian droughts, a 1987 decree designated the South as a semi-commons, affirming the rights of agro-pastoralists to forbid livestock from grazing within cultivated areas during the growing and harvest periods and collect sanctions from offending pastoralists. While this political move strengthened political support of newly decentralized governments by providing greater land tenure security, it was stated in the aftermath of Kountché’s remarks to “clear the fields” and cultivate to gain land tenure, a statement made in direct consequence to the famine stemming from the great droughts. What occurred on the ground as a result of the 1987 decree is that the southern zone shifts seasonally to a full pastoral space after department officials declare the *libération des champs* or “freeing of the fields.” The date is determined by a department-scale committee made up of individuals from the government administration and customary authorities as well as the technical representatives from the ministries of livestock and agriculture. Prior to the *libération des champs*, livestock are only permitted to graze in designated pastureland (Niger Decree N° 87-077 1987). This also established the very lucrative framework, which then permitted agro-pastoralists (cultivators) to collect compensation if crops or residues are damaged prior to the liberation, at a rate determined by local and sub-national institutions (Table 1). These two legislative acts alone were sufficient to provide several alternative sources of income to rain-fed agriculture, in the case of a drought. In turn, these policies stripped pastoralists of their rights to mobility, effectively limiting their greatest drought adaptation mechanism.

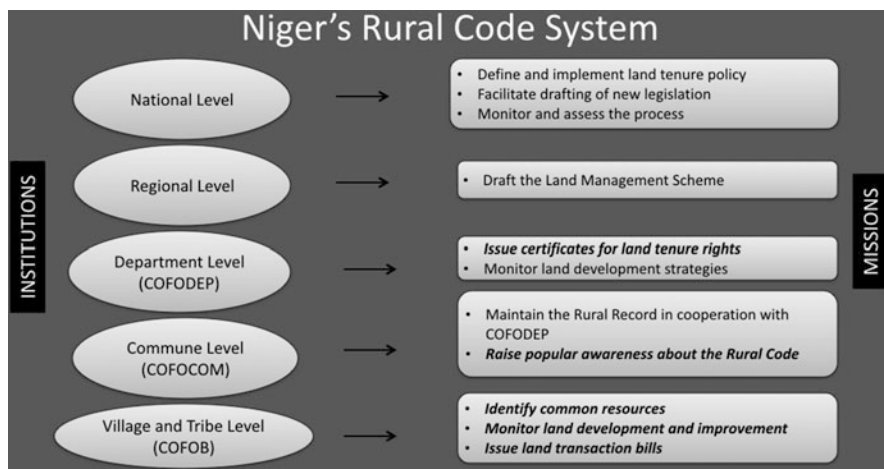
In 1993, the Rural Code established formal rules to land and water access and tenure. The ensuing privatization of territory culminated a national development plan to enhance the rural sphere for agribusiness opportunities, including large-scale irrigation, livestock fattening, and agroforestry. Land began to be more formally appropriated via a process that began with permission from customary authorities (canton chiefs handle all land claims in southern Tahoua) and moved into the realm of newly established land commissions. It was relatively easy for sedentary populations to garner land claims based on verbal reference from two separate individuals. Many pastoral communal areas, thus, were cultivated. Protecting commons required a more complex and costly collective action process, engaging multiple administrative actors including land commissions (Fig. 2) and customary authorities in the South; thus, pastoral territories have been often ignored (Touré 2015).

The 2010 Pastoral Code seemed to provide the possibility of reinforcing mobility to disenfranchised pastoralists. The Code’s aim was to fill the gaps, define, and specify the rules and principles concerning pastoralism and what the 1993 Rural Code had previously established (Snorek et al. 2011). The Pastoral Code mandates

**Table 1** Description of Niger's pastoral and agro-pastoral legislation. (Adapted from a similar table in Snorek et al. 2014a)

Legislation relevant to divergent adaptation in Tahoua		
Name	Description	Relevance to divergent adaptation
Law N°61-05, 1961	Sets the geographical limits to cultivation (with the exception of small gardens)	Pastoralists lost territory to cultivation, as the limit moves northward annually
Decree N°87-077, 1987	Permits pastoralists to graze in southern agricultural zone after harvest or in designated areas	Concurrently permits the sanctioning of pastoralists by land-holding agro-pastoralists
Ordinance N°93-15, "Rural Code," 1993	Recognition that natural resources are shared by all equally, supported creation of livestock corridors and pasture areas	Organizes rural sphere (commons and semi-commons), yet many administrators have no understanding of its content
Law N°93-14, 1993	Private and public water sources (ponds, wells, boreholes) must be accessible to pastoralists, provided the load capacity of the infrastructure allows for this	This has not been implemented in the South, resulting in exclusion of pastoralists from water points
Decree N°97-007/PRN/MAG/EL, 1997	Establishes home territories ( <i>terroir d'attache</i> ) in which pastoralists have priority rights over natural resources, but cannot limit others' access	Home territories remain an enigma due to the legislation's vague treatment of this important historical pastoral territorial tenure practice
Decree N°97-008/PRN/MAG/EL, 1997	Sets the organization, attribution, and functioning of institutions implementing the principles of the Rural Code	Established weak land commissions ( <i>commission foncières</i> (COFOs)) without decision-making power, resulting in corruption
Decree N°97-368/PRN/MHE, 1997	Sets attributes and modalities for COFOs of communes, villages, and indigenous groups	Poorly implemented village COFOs with few pastoral representatives
Law N°2001-23, 2001	Established democratic, decentralized administrative constituencies and local authorities	Land tenure decisions devolved from customary authority to multiple authorities, "democracy" to blame for land tenure disputes
Ordinance n° 2010-029, "Pastoral Code," 2010	Codifies a pastoralist's right to mobility	Protects pastoral territories and enhanced open-access property regimes void of local institutional norms
Ordinance n° 2010-09, "Water Code," 2010	Management of Niger's water resources	Established open-access property regimes on northern pastoral territories, permitting pay-for-use, private wells

livestock safety of passage and access to water points and areas of pasture in the zone of cultivation. It creates a legal framework for interaction between people whose livelihood is based on animal husbandry and other groups such as agriculturalists, mining companies, or commercial livestock production on ranches (ibid.). While these developments were heralded as important advances in the recognition of



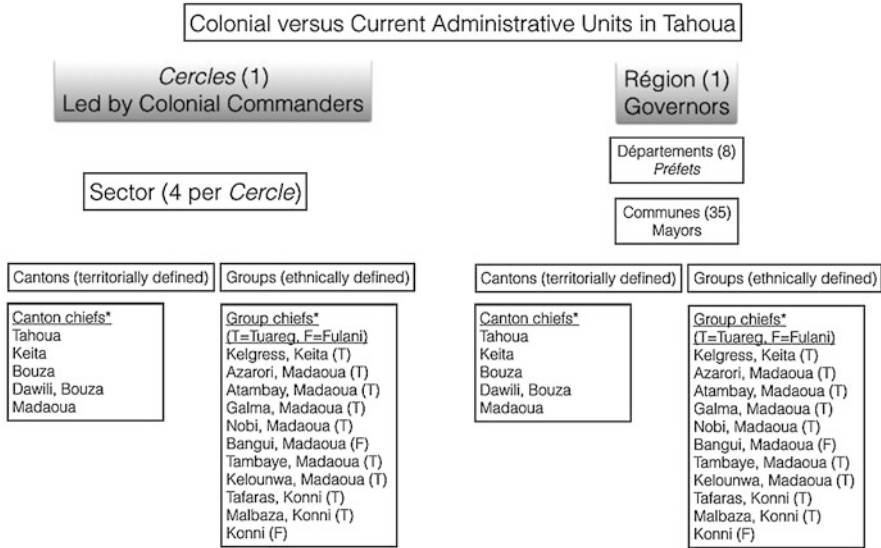
**Fig. 2** Niger's Rural Code System presents a decentralized manner to disseminate, communicate, and implement rural legislation (bold text more relevant to conflict dynamics). COFO = *commission foncière* or land commission. (Snorek et al. 2014b)

pastoralists' rights, the Code further erodes customary control, which was considered to be a messy form of pastoral governance (Oxby 2011).

## Multiple Sub-National Governance Arrangements

The reality for pastoralists, however, is that their main advocates were customary pastoral leaders. Under the colonial regime, the sub-national sphere was arranged into sedentary (farming) communities and mobile (pastoral) communities. *Cantons* (Fig. 3), headed by sedentary chiefs, are defined by territories that were arranged based on colonial interests, whereas the *groupements* (groups headed by pastoral chiefs) were based on ethnic groups linked to pastoralist actors (Fulani and Tuareg) and do not control territory. To encourage acceptance of these conditions, pastoralists were told that their territory was essentially "everywhere," but these chiefs were only permitted de jure jurisdiction over individuals, remnants of which have had broader implications in the protection of pastoral lands in modern day. Despite that the colonial period ended in 1960 with the election of Hamani Diori, the system of cantons and groups (generally referred to as customary authorities) remains in place (Fig. 3).

Beginning in 2002, the power of customary authorities began to erode through a process of state or administrative decentralization, which established municipal administrative units (commune mayors, departmental *préfets*, and regional governors, Fig. 3). Decentralization has contributed to a gradual shift of jurisdiction over land holdings from customary chiefs to democratically elected leaders, which have included land formalization processes (Hammel 2005). Perspectives on



\*Limited to those intervening in the study area

**Fig. 3** Colonial remnants (left) and decentralized (right) regional administrative units in Tahoua, arranged hierarchically. Democratically elected governors, *préfets*, and mayors replaced the upper scales of regional governance, leaving in place the colonial institutions at the local scale. These colonial structures include *cercles* (now called “regions”), managed by commanders; *sectors* (now departments and communes), managed by military lieutenants; and *canton* and *groupement* (maintained same name), managed by local chiefs appointed by colonial administrators. *Chef du canton/groupement* or *canton/group* chief is the unit of rural leadership serving as the administration, justice, and police for rural peoples. (Source: author)

decentralization are highly variable and have been explained in more details in other texts (Mohamadou 2009; Olivier de Sardan 2011), though two viewpoints contextualize the responses from expert and household interviews. Firstly, state officials argue that customary officials are not democratically elected and thus become more easily corrupt and entrenched in the past. Contrariwise, the fragmentation of knowledge of short-term elected leaders is not favorable to the build continuity in relation to land arrangements and decisions, due especially to poor documentation and corruption. At the local scale, perspectives on decentralization are largely conflated with what people call “democratization.” The results of democratization to local-scale users include local problems such as confusing land-holding arrangements, political alliances linked to campaigns and parties, and significant political bargaining related to land tenure.

While group chiefs have strong commitment to maintaining pastoral rights to pasture and water, they must interact effectively with other governance actors (*préfets* and mayors) to enforce pastoral rights, due especially to colonial legacies that established pastoralists as mobile and landless. Pastoral territories are mostly lost to cultivation, due to beliefs that the land belongs to those who cultivate

it. Moreover, group chief distribution across administrative departments is not equal; Keita has only one group chief, whereas Madaoua possesses seven (Fig. 3). Despite the established procedures under decentralization, we found that in situ, land tenure is managed informally by group and canton chiefs and hand-written records (*Procès Verbal* (PV)) were often lost or unavailable (Table 2). The most common complaints are related to heritage claims, crop damage, and disputes over the location of pastoral commons. When actors were dissatisfied with a customary chief's decision, they turn to elected officials to find different outcomes. For example, a case that had been dealt with by a Fulani chef du *groupement* whom we were interviewing was usurped by a newly elected official 1 year later, causing the issuance of a land title for what had been declared the year prior as a pastoral area. Implementation often proves to be much more complex due to uncoordinated, multiple layers of governance.

The national and sub-national institutions presented here frame the outcomes from divergent adaptation in the local sphere in multiple ways. The next section describes how the institutional arrangements translate in the divergent adaptation arena in two case studies, one in the northern agro-pastoral zone (Keita) and one in the southern cultivation zone (Madaoua). Both of these cases are characterized by the dominance of agro-pastoral livelihoods, but the southern semiprivate property regime has a greater number of irrigated, enclosed gardens due to better water and soil conditions. Paradoxically, higher levels of natural resource-based conflicts were prevalent in the northern, more sparsely populated agro-pastoral zone compared to the highly concentrated, southern irrigated gardening and agricultural zone of Tahoua, contradicting neo-Malthusian assessments of scarcity and farmer-herder conflict in the Sahel (Bruggeman et al. 2010; Homer-Dixon 1999).

### **Conflict in the North: The Agro-Pastoral Keita Department**

The agro-pastoral department of Keita (Fig. 1, Locale AP) sits in a precarious location with its northern border on the shifting and disputed edge of the pastoral zone and arid mountains and humid valleys to the South. The Keita Valley, which currently receives on average 337 mm of rainfall per annum (Fig. 1), unites four watersheds in the region of Tahoua, the Adouna, Tarka, Jangay, and Jaboyé valleys, and is surrounded by mountains and plateaus. Because of its potential for water management, the French colonial authorities built a dike in Keita in 1952, forming a large lake suitable for fishing, irrigation for wheat production, and bird-watching. Prior to this time, Keita was primarily inhabited by the Wodaabe (a subgroup of Fulani people) pastoralists and their cattle. The colonial investment brought migrant farmers, established two canton chiefs in Keita and Tamaske, and established wheat cultivation, developments which essentially pushed the Wodaabe northward in search of sufficient pasture. The KelGeres, a subgroup of the Tuareg, also had one group chief near the Akawal Plateau (Image 2), whose people migrated between Agadez and Keita up until the drought in 1974. This chief vehemently defends the Tuareg's historical land occupation of Keita and complains about how it has been overtaken by Hausa farmers, many of which he and his predecessors granted land

**Table 2** Percentages of qualitative responses about specific social dynamics relevant to divergent adaptation. Codes for similar responses are listed on the left, and the percentage responses disaggregated by actor group are displayed

Social and institutional dynamics	Locale AP – Keita		Locale A – Madaoua	
	# of agro-pastoralists (N = 22)	# of pastoralists (N = 16)	# of agro-pastoralists (N = 9)	# of pastoralists (N = 10)
<b>Conflict</b>				
Existence of arms	9% (2)	13% (2)	0	10% (1)
Presence of livestock theft	41% (9)	38% (6)	22% (2)	30% (3)
Conflict on water access	5% (1)	13% (2)	0	30% (3)
Damaging crops	68% (15)	38% (6)	44% (4)	10% (1)
Violence	55% (12)	0	44% (4)	0
<b>Rules, sanctions, enforcement</b>				
Livestock corridors not protected	0	31% (5)	0	100% (10)
Locally derived enforcement	23% (5)	0	33% (3)	10% (1)
Payment for damaging crops	27% (6)	44% (7)	44% (4)	50% (5)
No payment for crop damage	27% (6)	6% (1)	11% (1)	0
<b>Governance</b>				
Trust in gendarmes	36% (8)	6% (1)	0	0
Trust in customary officials	18% (4)	6% (1)	44% (4)	30% (3)
No trust in elected officials	14% (3)	25% (4)	22% (2)	60% (6)
No trust in customary officials	4% (1)	12% (2)	11% (1)	10% (1)
All officials are corrupt	41% (9)	13% (2)	0	10% (1)
Elected officials favor cultivators	9% (2)	56% (9)	11% (1)	50% (5)
<b>Social capital between groups</b>				
Marriage of “other”	5% (1)	6% (1)	0	20% (2)
Other group as problem	55% (12)	63% (10)	22% (2)	50% (5)
Transactions between groups	14% (3)	4% (1)	66% (6)	20% (2)
Cooperation and acts of kindness	5% (1)	6% (1)	0	50% (5)

tenure. He is the only customary chief in Keita representing pastoral interests, and he was approximately 100 years old at the time of our visit.

In the 1950s, Keita's wetlands were abundant, nourishing low-lying areas with nearly year-round cultivation of millet, several strains of sorghum, and some vegetables; however, according to Keita's canton chief, when the dike of Keita broke for the first time in 1964, the valley became eroded and the water table lowered, leaving behind many dry wells and sediment-filled waterways. The loss of this infrastructure was followed by two periods of drought in 1974 and 1984, during which a burgeoning farming population cultivated much of the territory, removing trees and causing vast deforestation in the zone, promoting erosion, soil degradation, landslides, and property loss. Concurrently, soil loss and desiccation promoted that water run off the hillsides and across the valleys to lower ground, which formed into a lake in an adjacent commune, called Tabalak. Today, due to water shortages, a woman's dowry must consist of at least a donkey, to enable her to travel a sufficient distance in search of water (Image 1).

After the disastrous drought of 1984, the Italian-funded Ader Douchi Majiya Project began a massive reforestation effort and concurrently built many water-retaining infrastructures throughout the department to increase food security in the region (Rossi 2002). More than \$88 million was invested in forest and soil regeneration in the region over the course of 25 years. Concurrently, Italian initiatives attracted migrants from around the region to Keita, due to promises of plots of land by the project, which prompted an expansion of cultivation and further displaced transhumant pastoralists (Image 2). Keita thus shifted from a sparsely populated pastoral zone to a burgeoning agro-pastoral livelihood zone in the span of 50 years.

Every year, transhumant pastoralists descend into Keita as the seasonal lakes dry in the Northern pastoral zone, typically in October and December. The official declaration of the *libération des champs* typically occurs in Keita during November or December. Pastoralists descending earlier than this typically remain on designated corridors and in pasture areas, when available. If the pastoral zone received less rain, this departure is earlier, often before the *libération des champs*. Pastoral infrastructure including transhumant routes, pastoral wells strategically located along these corridors, and pasture "rest" areas (*aires de pâturage*) have been installed throughout



**Image 1** (Left) Denuded hillside shows extreme erosion of Keita, Niger (author). (Right) Women travel by donkey in search of water (author)





**Image 2** Image of a pastoral well surrounded by recently planted fields (Keita, Niger, author)

Keita as part and parcel of the Ader Douchi Majiya project's efforts to support pastoral and agro-pastoral development. During our field visit, a primary transhumant corridor was not being used due to water access problems, curtailing the southern transhumance through farmer's fields (Table 2). Also, upon inspection, many pastoral wells identified by respondents had been or were in the process of being enclosed by cultivated fields (Image 2).

Drought policies established in the 1990s promoted agro-pastoralism or animal husbandry in farming households as a form of investment in light of the vulnerability of rain-fed agriculture to rainfall variability. While policies were effective in bringing foreign aid and development programs supporting "animal fattening" for sedentary households, farming households in Tahoua complained about the lack of fodder for fattening. As a result, the governor promoted the cutting and stocking of farming residues, which before had been left in the fields to decay or be consumed by any of the livestock passing through after the *libération des champs*. This lengthened the timing of agro-pastoral work, as field residues must be fully dried in the field prior to stocking, and thus delays the date of the *libération des champs*. Such residues sometimes bring in more revenue than grain due to drought, though their removal has reduced soil fertility and increased agricultural vulnerability to climate hazards. Concurrently, these policies break the territorial continuity for pastoralists, greatly impacting their fodder source through commodification of fodder as well as broadening the range of what is considered "crop damage."

Thus, the divergent adaptations expressed in Keita include the commodification of farming residues and water due to the animal fattening project, the enclosure of pastoral wells and corridors via field expansion, and the sale of water from village wells when pastoral wells are not accessible or viable. Relative to these divergent

adaptations, pastoralists expressed a great deal of fear about passing through the Keita department, due to the outcomes of divergent adaptation and also due to their limited representation in the department by pastoral institutions or even other officials in the elected administration. The interactions and outcomes are described below.

### **“Trapping” Livestock in Keita’s Divergent Adaptation Arena**

Agro-pastoralists in Keita see the need to expand their agricultural fields from the valleys to the traditionally pastoral plateaus, as this is the only way to “catch” spatially and temporally variable rainfall. Their legal ability to expand their land tenure has been established by multiple legal codes and verbal precedent. While the expanse of cultivation alone tends to increase agro-pastoralists’ adaptive capacity in the face of drought, the Decree N°87-077, 1987 (Table 1), allows the sanctioning of the owner of any livestock wandering into one’s field. These sanctions can be costly, charged by the head and type of animal. Payments to release livestock cost on average 8 USD for large and 5 USD for small ruminants per head, which adds up to a hefty sum for a herd of 20 cattle. As income from millet and sorghum production has become less reliable, crop damage payments extracted from pastoralists have proven to enhance livelihood security for those experiencing damages. Thus, expansion is a lucrative “trap” for rainfall and for livestock. As stated by an agro-pastoralist from Konni, “Each one who damages [crops], the Hausa [farmers] make him pay money. But [before] there was pasture and the camels could go where they wanted, but now there are people everywhere. And there are fields of onions everywhere.” Some villagers sleep in their fields to protect them from harm and also to “trap” pastoralists. To divert pastoralists, village residents living near pastoral corridors remove official markers and plant to claim the space.

Fear of “the other” shapes this conflict, which at times turns violent (Table 2). But leadership in Keita tends to be sympathetic toward agro-pastoralists while perceived that pastoralists damage crops with impunity. “[They believe] that if their cows spend 3 months grazing in that valley, they can withstand a drought,” said a Keita area vice mayor in reference to a sorghum-filled valley. Elected officials and customary canton chiefs have turned to enforcement officers to help manage the conflict. As cell service becomes more available in the zone, a pastoralist “descent” warning system has been established. Upon seeing the first pastoralists descending from the North, village chiefs immediately phone the *gendarmerie* (military police) to request their assistance. These gendarmes stay in villages to both prevent conflict and also (with the same motivation for payment) “catch” any livestock wandering into fields and damaging the harvest. Gendarmes were observed packing several sheep into the back of a government vehicle during the research team’s passage. These were the payment for the gendarme’s protection of a villager’s field from crop damage (Image 3).

The presence of gendarmes has not been welcomed by all. Agro-pastoralist respondents prefer localized forms of compensation and conflict resolution

**Image 3** Gendarme vehicle with confiscated sheep (Keita, Niger, author)



(Table 2). When gendarmes profit from crop losses, this lessens the compensation paid to farmers. Moreover, this enforcement disrupts the long-standing cooperative system of negotiation between both groups. “Before, when the Fulani pastoralists put their livestock in our fields, we’d intervene ourselves to chase them away, but we noticed that when the gendarmes are here, it is us farmers who are punished for intervening, so since then, we do not intervene anymore ” (pastoralist in Keita).

Pastoralists, realizing that safe transhumance is dependent upon land tenure, have settled in several makeshift villages and begun cultivating to establish a resting area for their kin traveling along the transhumant routes. Yet for those pastoralists who depend upon mobility as their adaptation to climate variability, they often lack an alternative to entering cultivated fields. So, to avoid conflict, pastoralists in Keita travel through fields under the cover of night, escaping to the mountains before they can be detected, and their livestock confiscated as collateral.

As a form of solidarity to pastoralists, some Keita cultivators cleared their fields early when the pastoralists began to descend. These also preferred negotiating a token amount convivially for crop damage. Despite these examples of cooperation, pastoralists have resorted to protect themselves and their safe passage by shooting arrows at farmers and gendarmes. This has resulted in several severe injuries among local agro-pastoralists and enhances the fear and distrust between both groups. In Keita, when the problem cannot be resolved at the local level, violence replaces the endemic systems of livelihood protection including cooperation, negotiation, and discussion to maintain pastoral mobility in this department.

Despite the gendarme’s involvement in Keita, very few cases of crop damage are recorded in Keita. Only eight cases were registered between 1997 and 2011. No earlier records were available. The *Procès Verbaux* (PVs) averaged payments of 172 USD, and half included cases of violence. Three of the crop damage cases were handled by the gendarmes, and one was negotiated by the land commissions (COFO). Only one litigation was relevant to protection of pastoral space (see Table 2), and it was resolved in favor of pastoral rights.

## Cooperation and Customary Chiefs: The Heavily Cultivated Madaoua Department

To the South, Madaoua is a mixed use zone with a high prevalence of irrigated (winter) cultivation and a series of livestock routes passing to the higher-value markets of Nigeria. One central exodus point is the commune capital of Bangui, where nearly four million FCFA (8,000 USD) in export taxes were collected in October and November 2011. Along with livestock exports, the region produces onions by the truckloads. Rainfall in Madaoua is slightly greater than Keita (386 mm, Fig. 1) which is evidenced by the many seasonal lakes in the department as well as a higher water table. Contrary to the rocky hillsides and deep valleys evidenced in Keita, Madaoua is a broad plain, met by a large dry riverbed along what is now the southern border of Niger.

The average farmer cultivates rain-fed crops like millet, sorghum, and cowpea in the summer (May–October), and those who have been lucky to obtain a coveted valley plot cultivate and sell onions or other vegetables in the winter (October–January/February). Irrigated cultivation is typically reserved for the valleys and low-lying areas where it is possible to dig a shallow well, and irrigation is derived by hand or with a diesel-powered pump. In Madaoua, these irrigated crops are often *not* protected by fencing, so that herding requires careful observation and guarding of livestock even after the *libération des champs*, to avoid the heavy fees charged to damage to this high-value irrigated agriculture. Every space appeared to be cultivated across this zone, saving a few pastoral corridors and pastoral rest areas.

In the precolonial period, Madaoua was occupied by Fulani herders and Hausa farmers, both of which used Sokoto, Nigeria, as their commercial and political capital. The Fulani herdsmen who dominated the zone called the place Bangui after a large cow by that name that died in the location. Due to the abundance of water, residents cultivated rice in the valleys. Farmers tended to plant in the paths of their pastoral neighbors putting seeds in soil fertilized by the livestock. The reciprocity of this practice shifted with population growth, and land was organized into farming and livestock areas. The Fulani pastoralists considered that they had more rights “before the moment of democracy,” because “the customary chiefs [of today] have no protocol [for protection.]” “During the time of Ibrahim [a Fulani chief], there were never any problems. He would get on his horse, come, and say, ‘here it is the pastoral are,’ stating to pastoralists, ‘if the people plant this, just come and graze it anyway.’” Upon his death in 1999, cultivators overtook these zones.

Increasing temporal and spatial variability of rainfall as well as demographic growth shifted the patterns of cultivation and livestock rearing in this department. To adapt to rainfall variability, agriculturalists become agro-pastoralists, holding livestock as “drought insurance” and cutting the crop residues from their fields for fodder. Concurrently, many residents in Madaoua, to increase their chances of receiving rainfall, purchase fields in other villages, hoping to increase their chances of the rain falling on their crops. Bangui is located along an international livestock corridor established in 1968 and stretching for 90 kilometers from Nigeria to Keita (Image 4). However, as villages have grown, their populations have enclosed pastoral resources.



**Image 4** (Left) A village on the border of Nigeria (Bangui) has grown around the pastoral well on the international livestock corridor and (right), a disputed seasonal lake in northern Madaoua is forbidden to pastoralists by the village leaders. (Madaoua, Niger, author)

Near Bangui in Locale A, the valleys are moist nearly all year. As a result, the villagers grow high-value crops such as cowpea, sorghum, and some squashes. The residues are sold to livestock owners. On the dune behind the valley, the villagers grow millet in nutrient-poor soil, for which some pastoralists are contracted to “sit” in farmers’ fields with their livestock. These informal contracts are paid at a rate of approximately one sack of millet per month. Valleys are rarely penetrated by livestock, despite that they grow a desired food. Farmers bring field residues to the livestock sitting in fields, as another form of exchange. Livestock rarely damage crops, despite the fact that there is only one small route to water. Pastoralists pay higher rates to consume the cowpea vines; they are especially interested in fattening their animals to sell in Nigeria.

If there was a conflict, Madaoua has multiple customary chiefs – one canton and six group (five Tuareg, one Fulani) chiefs living in the commune (Fig. 3). They meet frequently, sometimes traveling long distances or hosting events or gatherings at their own expense or with the assistance of government and pastoral associations (see *Association pour la Redynamisation de l’Elevage au Niger* [AREN]) in order to meet with their constituents before, after, or during the biannual transhumance. During these face-to-face discussions, pastoralists are able to raise concerns about the route and access to water. Their efforts to control the territory have sometimes resulted in cooperation between sedentary and pastoral groups, yet dialogues also fail and devolve to nonviolent conflict. Based on the *Procès Verbal* (PV) from Madaoua, six cases of land and water conflicts were recorded from 1999 to 2010. Of these, three were handled and recorded by village chiefs, two for crop damage, and one related to the protection of a livestock corridor. The other litigation was managed by the canton chiefs (2), the group chief (1), and the Court of Appeals (1). Three of the recorded conflicts enforced the protection of pastoral commons.

### **Communication Promotes Collective Action in Madaoua’s Divergent Adaptation Arena**

Despite large tax income from livestock, institutions do not do a sufficient job of protecting pastoral space. Respondents often blamed democracy or decentralization.

“[N]ow with the democratization, [protection of pasture] has become a problem. Even if you see someone planting in the *aire du pâturage*, they [the customary chiefs] will say that they are coming, but they never arrive.” Despite pastoralists’ complaints, elected officials do little to manage common pastoral spaces due to a desire to garner favor (votes) among the more populous Hausa people, who typically have large families and thus need land tenure for their children’s inheritance. All of the pastoralists in this area complained of the lack of safe corridors for their passage due to encroachment (Table 2). Cultivators often dispute ownership of pastoral space, declaring that it was cultivated by their ancestors. During one such dispute, the Fulani chief and Hausa cultivator argued about historical rights to the land without resolution (Image 5).

Average payment for crop damage is higher than in Keita. This forces pastoralists to be more vigilant. In turn, crop damage costs are frequently negotiated face-to-face between parties, with the support of customary officials. For rain-fed crop damage, the average cost per head for a large ruminant is 14 USD, and for a small ruminant, it is 6 USD. For garden damage, costs are higher, typically 215 USD. Some of the agro-pastoralists we interviewed tended to forgive crop damage, even for those pastoralists who were foreigners to the zone, but this practice of forgiveness was not common (Table 2). Other villagers in Locale A thought that damage was the fault of the field owner for not guarding his field properly (Table 2).

Along with the high-cost sanctions, these normative responses are also due to administrative support of peaceful resolution. Administrators, group, and canton chiefs in Madaoua (Fig. 3, Image 5) prefer face-to-face discussions to prevent conflict. At the beginning of the descent, Fulani and Tuareg chiefs from five groups travel with administrators to every commune in Tahoua to discuss conflict resolution measures including places to safely “rest” their livestock and how to manage conflict. When these visits are finished, the chiefs return to villages in Madaoua, some of which are along the pastoral corridors. Locale A is very strict about pastoralists entering the village, even along the international livestock corridor, which is just south of the moist valley. When the harvest is complete, village chiefs grant pastoralists entry, and if these rules are not followed, higher-level customary chiefs are quickly called in to negotiate. When describing one such occasion,

**Image 5** Agro-pastoralist discussing crop encroachment into pasture area with Fulani group chief, during our community mapping of Bangui (author)



pastoralists may wait in already-harvested fields, which may concurrently serve as a “contract” for fertilization services.

Thus, crop damage is solved without violence and through conflict prevention. Locale A’s chief explained the first resort, to negotiate with offending pastoralists, and second resort, to call upon the administrators and customary chiefs in the commune capital Bangui (20 kilometers away). There was never a need to take any further action. Locale A experiences few violent conflicts (Table 2) but communicates frequently with both pastoralists and local and regional institutions. If local chiefs need assistance with a conflict, local officials engage both parties in face-to-face conversation about the problem, evoking discussion among multiple parties. When asked how they manage to maintain peace despite the descent of pastoralists into the village, an agro-pastoralist replied: “The pastoralists need to talk with the farmers. Otherwise, we don’t have many ideas. Calling the administrators is the best solution. . . . Yes, [sometimes the customary chiefs have discussions with the population], and it is valuable” (Madaoua pastoralist).

### “Democracy as Problem”?

What some agro-pastoralists and pastoralists termed “democratization,” referring to the decentralization process in Niger, has created overlapping layers of governance (customary/elected official/COFO). In turn, this has produced a resounding accusation that “democracy is the problem,” referring to patterns of corruption that have been supporting the marginalization of pastoralists. Pastoral commons, which have in the past been identified and protected by group chiefs, have declared the property of sedentary groups as a way of garnering their votes in the democratic system. This outcome is synchronous with rent-seeking behaviors across these new layers of governance.

In the context of this nascent democratic system, the creation and distribution of entitlements are related to elite capture processes that subjugate the rural pastoral more than agro-pastoral systems. This is a key institutional factor contributing to divergent adaptations such as the expansion of cultivation into pastoral space and the commercialization of field residues. In Keita, multiple scales of institutional actors (gendarmes, local chiefs, administrators, etc.) induce an atmosphere of fear resulting from heavy enforcement of crop damages and rent-seeking from both rural actors (pastoralists and agro-pastoralists). The *gendarmerie* engages in sanctioning pastoralists, in some cases confiscating pastoral property with impunity. Thus, there are high perceptions of corruption in the zone and low levels of social capital between user groups (Table 2). Gendarmes, in turn, reinforce these biased accounts of the codes by failing to protect pastoral commons. These conditions have been found in similar case studies of farmer-herder conflict (Benjaminsen et al. 2012) and result in these groups seeking other means to defend their livelihood, including violence (Snorek et al. 2014a).

In Madaoua, actors in Locale A mentioned fewer conflict dynamics and more locally derived systems of collective action and enforcement (Table 2). Moreover, the behaviors mentioned during conversations with individuals at the local scale exemplify that actors are informed of how to seek help from leadership, are

empowered to solve their own problems (through dialogue with the chief), and understand planned measures and support systems (a step process of seeking support from local and external sources), which are elements that are reflected also in polycentric, adaptive institutions (Gupta et al. 2010; Ostrom 1999; Berman et al. 2012; Allen et al. 2010). Due to high levels of marginalization of pastoral actors, having a higher number of group chiefs living in Madaoua has helped to enhance opportunities for collective action due to the greater representation through these chiefs. Villagers in Locale A stated that they would ask the help of outside administrators or customary officials for the purpose of preventing conflict. Administrators and customary officials from sub-national scales participate in deliberation processes and negotiate solutions through face-to-face dialogues with multiple actors.

Neo-Malthusian concepts of scarcity induced by concentrated land use and demographic growth would state that Madaoua is a more likely case for scarcity-induced conflict. Yet despite the divergent adaptations, coupled with factors of exclusion (due to expanding cultivation) and marginalization (represented by ignorance of the need to protect pastoral spaces) present in both case study areas, Keita faces greater conflict. Crop damage is present in Madaoua, and sanctions are justifiable means of reducing crop damage. Yet unlike in Keita, sanctions are not used for elite capture, nor do they serve as a means of marginalizing pastoral actors. Rather, face-to-face conversation (Ostrom 1999) is a means to support collective action over common pool resources. As a result, both actor groups perceive communication as essential to the annual transhumance and shifting of land tenure regimes through the *liberation des champs*. Furthermore, social innovations such as “livestock waiting areas” in agro-pastoral villages enhance agency and provide spaces for social learning to take place in safety and security. This local mechanism for preventing both damage and conflict is possible both because of the history of communication between actors, the presence of physical pastoral enclaves or waiting areas, and the open and transparent sharing of information in Locale A, Madaoua.

To overcome marginalization and spatial exclusion, institutional actors at the local scale need to have more support from government officials including access to land, fodder, and water to support pastoralists during their passage. While some efforts to maintain pastoral water access remain entrenched in age-old systems that profess that pastoral commons cannot be enforced (Hardin 1968), there is a greater concentration and historical presence of charismatic leadership among pastoral customary leaders in Madaoua to negotiate and overcome these challenges (Ostrom 1999; Gupta 2010). This emphasizes the importance of representation by customary officials who, in turn, interact closely with their constituents and speak on their behalf to defend livelihood access rights and support other complex and uncertain livelihood trials stemming from divergent adaptations.

---

## Conclusion

This chapter illustrates how institutions, especially those at the local scale, shape divergent adaptation. Analyzing responses from pastoralists, agro-pastoralists, and multiple customary and administrative officials in Niger identified two divergent



adaptations prevalent in the case study areas: (1) the closing of pastoral spaces by cultivation, which is related to crop damage payments, and (2) limited water and fodder access and availability due to agro-pastoralism and cutting of field residues. For both of these, the adaptive capacity of pastoralists is reduced. Yet, despite the similar typology of the divergent adaptations, the in situ institutions produced different outcomes in each locale.

The violence experienced between pastoralists and agro-pastoralists in Keita, exemplified by the presence of arms, livestock theft, and land and water access, was in contradistinction to the way that conflict was experienced in Madaoua, where informants did not negate the presence of conflict, but identified more preventative and cooperative behaviors including transparent information and itinerary sharing, availability and support from multiple institutional scales, transactions such as farmer-herder “contracts,” expressions of cooperation and kindness to the other group, and trust of local, customary officials. These outcomes contradict neo-Malthusian logic that posits that increased human concentrations lead to scarcity dynamics (Homer-Dixon 1999) and support the idea that conflict is relevant to how institutions frame adaptation (Snorek et al. 2014a). Reflecting these and other findings (Kpadonou et al. 2012), local-scale, collective action institutions are more capable of promoting trust, cooperation, and reciprocity through face-to-face discussion of rule and expectations (Gupta et al. 2010; Ostrom 1999).

Integrating adaptation planning and institutional capacity building across administrative jurisdictions is essential to sustainable, peaceful adaptation outcomes in Niger. The adaptation needs of mobile pastoralists demand uninterrupted and well-stocked pastoral corridors and resting areas. Yet when their needs are not met, suppression of conflict equates to greater conflict. As other research has shown (Snorek et al. 2014a, 2017), institutions that encourage expressions of conflict by direct confrontations, dialogue, and discussion may better promote sustainable adaptation than the top-down, conflict-suppressing institutions exemplified in Keita, as the latter tend to reinforce unequal power relations and promote marginalization. By enhancing institutional models that provide space and time for collective action, multiple users can express and discuss their adaptive capacity needs, which have greater potential to bring about more sustainable, peaceful adaptation (Eriksen et al. 2011), especially for groups facing livelihood insecurities, social and climate vulnerability, and marginalization. Furthermore, as was demonstrated in the cases and in other research (Niamir-Fuller 1998), flexibility in resting points and enclaves as well as more transparent information about timing and spatial constraints related to the clearing of fields is essential to peaceful adaptation and will require more locally mediated and managed models of governance.

This chapter shows that local institutions that support engagement of multiple groups in collective action processes tend to lessen the tensions relevant to divergent adaptation. This research further elaborates (Snorek et al. 2014a, 2017) how divergent adaptation is a process that can change institutions *through* conflict or cooperation dynamic and should be applied to other social, ecological, and political contexts, to further examine how to bring about more peaceful and sustainable adaptation.

**Acknowledgments** The research was funded as part of the 3-year European Commission Seventh Framework Program CLICO (Climate Change, Hydro-Conflict, and Human Security), devoted to the study of climate change.

---

## References

- Adger WN (2001) Scales of governance and environmental justice for adaptation and mitigation of climate change. *J Int Dev* 13:921–931. <https://doi.org/10.1002/jid.833>
- Adger WN, Kelly PM (1999) Social vulnerability to climate change and the architecture of entitlements. *Mitig Adapt Strateg Glob Chang* 4:253–266
- Adger WN, Paavola J, Huq S, Mace MJ (2006) Fairness in adaptation to climate change. MIT Press, Cambridge, MA
- Adger WN, Agrawala S, Mirza MMQ, Conde C, O'Brien K, Pulhin J, Pulwarty R, Smit B, Takahashi K (2007) Assessment of adaptation practices, options, constraints and capacity. Climate Change. Impacts, Adaptation and vulnerability. Contribution of working group II to the fourth assessment report of the intergovernmental panel on climate change, Parry ML, Canziani OF, Palutikof JP, van der Linden PJ, Hanson CE, eds, Cambridge University Press, Cambridge, UK, pp 717–743
- Adger WN, Pulhin JM, Barnett J, Dabelko GD, Hovelsrud GK, Levy M, Oswald Spring Ú, Vogel CH (2014) Human security. In: Field CB, Barros VR, Dokken DJ, Mach KJ, Mastrandrea MD, Bilir TE, Chatterjee M, Ebi KL, Estrada YO, Genova RC, Girma B, Kissel ES, Levy AN, MacCracken S, Mastrandrea PR, White LL (eds) Climate change 2014: impacts, adaptation, and vulnerability. Part A: global and sectoral aspects. Contribution of Working Group II to the fifth assessment report of the intergovernmental panel on climate change. Cambridge University Press, Cambridge, UK/New York, pp 755–791
- Alemu MG (2018) Insecurity, and marginality in pastoral spaces: the horn of Africa and the Sahel regions. *Strat Rev Southern Afr* 40(2):82–95
- Allen CR, Fontaine JJ, Pope KL, Garmestani AS (2010) Adaptive management for a turbulent future. *J Environ Manage* 92(2011):1339–1345. <https://doi.org/10.1016/j.jenvman.2010.11.019>
- Barnett J, O'Neill S (2010) Editorial: maladaptation. *Glob Environ Chang* 20:211–213
- Benjaminsen TA, Holden S, Lund C, Sjaastad E (2009) Formalisation of land rights: some empirical evidence from Mali, Niger, and South Africa. *Land Use Policy* 26(1):28–35
- Benjaminsen TA, Alinon K, Buhaug H, Buseth JT (2012) Does climate change drive land-use conflicts in the Sahel? *J Peace Res* 49(1):97–111
- Berman R, Quinn C, Paavola J (2012) The role of institutions in the transformation of coping capacity to sustainable adaptive capacity. *Environ Dev* 2:86–100
- Biasutti M, Held IM, Sobel AH, Giannini A (2008) SST Forcings and Sahel rainfall variability in simulations of the twentieth and twenty-first centuries. *J Clim* 21:3471–3486
- Bode S (2011) Mobilité et mutations: cas de la communauté de pasteurs Wodaabe du lignage des Suudu Suka'el de Tanout (Niger Centre-Est). Doctoral Thesis for the Department of Geography. University Abdou Moumouni de Niamey
- Bruggeman A, Hadjinicolaou P, Lange M (2010) Climate outlooks for CLICO case study sites. Cyprus Institute, Accessed online on 8 Mar 2013. [http://www.cyi.ac.cy/system/files/Bruggeman\\_et\\_al\\_Climate\\_Outlooks\\_CLICO\\_D2\\_1\\_Sep2010.pdf](http://www.cyi.ac.cy/system/files/Bruggeman_et_al_Climate_Outlooks_CLICO_D2_1_Sep2010.pdf)
- Cleaver F (2002) Reinventing institutions: bricolage and the social embeddedness of natural resource management. *Eur J Dev Res* 14(2):11. 20p
- Dennett D (2013) Intuition pumps and other tools for thinking. W.W. Norton and Company, New York
- Engle NL, Lemos MC (2010) Unpacking governance: building adaptive capacity to climate change of river basins in Brazil. *Glob Environ Chang* 20:4–13. <https://doi.org/10.1016/j.gloenvcha.2009.07.001>

- Eriksen S, Aldunce P, Bahinipati CS, Martins RA, Molefe JI, Nhemachena C, O'Brien K, Olorunfemi F, Park J, Sygna L, Ulsrud K (2011) When not every response to climate change is a good one: identifying principles for sustainable adaptation. *Clim Dev* 3(1):7–20. <https://doi.org/10.3763/cdev.2010.0060>
- Gunderson LH, Holling CS (eds) (2002) *Panarchy: understanding transformations in human and natural systems*. Island Press, Washington, DC
- Gupta J, Termeer C, Klostermann J, Meijerink S, van den Brink M, Jong P, Nootboom S, Bergsma E (2010) The adaptive capacity wheel: a method to assess the inherent characteristics of institutions to enable the adaptive capacity of society. *Environ Sci Policy* 13:459–471
- Hammel R (2005) Politiques de développement pastoral au Sahel. Les ambitions de développement de la coopération internationale et la dynamique du système pastoral nigérien. Analyses comparative et historique. Mémoire de Recherche soumis à l'Institut Universitaire d'études du développement, IUED. Genève
- Hardin G (1968) The tragedy of the commons. *Science* 162:1243–1248
- Herrero M, Addison J, Bedelian C, Carabine E, Havlik P, Henderson B, van de Steeg J, Thornton PK (2016) Climate change and pastoralism: impacts, consequences and adaptation. *Rev Sci Tech Off Int Epiz* 35:417–433. <https://doi.org/10.20506/rst/35.2.2533>
- Hill M (2013) Adaptive capacity, adaptive governance, and resilience. *Adv Global Change Res* 54:29–51
- Homer-Dixon TF (1999) *Environment, scarcity, and violence*. Princeton University Press, Princeton
- Hoque SF, Quinn C, Sallu S (2018) Differential livelihood adaptation to social-ecological change in coastal Bangladesh. *Reg Environ Chang* 18:451–463. <https://doi.org/10.1007/s10113-017-1213-6>
- IFAD (2016) Rural poverty portal. Accessed 26 May 2016. <http://www.ruralpovertyportal.org/country/statistics/tags/niger>
- Kpadonou RAB, Adégbola PY, Tovignan SD (2012) Local knowledge and adaptation to climate change in Ouémé Valley, Benin. *Afr Crop Sci J* 20(s2):181–192
- Lebel L, Anderies JM, Campbell B, Folke C, Hatfield-Dodds S, Hughes TP, Wilson J (2006) Governance and the Capacity to Manage Resilience in Regional Social-Ecological Systems. Marine Sciences Faculty Scholarship. Paper 52. [http://digitalcommons.library.umaine.edu/sms\\_facpub/52](http://digitalcommons.library.umaine.edu/sms_facpub/52)
- Lund C (1998) *Law power, and politics in Niger*. Transaction Publishers, New York
- Magnan AK, Schipper ELF, Burkett M, Bharwani S, Eriksen S, Gemenne F, Schaar J, Ziervogel G (2016) Addressing the risk of maladaptation to climate change. *Wires Clim Change* 7(5):646–665
- Mohamadou A (2009) *Decentralisation and local power in Niger*, IIED. Russel Press, Nottingham
- Mortimore M (1989) *Adapting to Drought. Farmers, Famines and desertification in West Africa*. Cambridge University Press, Cambridge, UK
- Niamir-Fuller M (1998) The resilience of pastoral herding in Sahelian Africa. In: Berkes F, Folke C (eds) *Linking social and ecological systems: management practices and social mechanisms for building resilience*. Cambridge University Press, Cambridge, UK, pp 250–284
- Olivier de Sardan J-P (2011) The eight modes of local governance in West Africa. *IDS Bulletin* 42(2):22–31
- Olsson P, Folke C (2004) Adaptive co-management for building resilience in social-ecological systems. *Environ Manag* 34(1):75–90
- Ostrom E (1999) Coping with tragedies of the commons. *Annu Rev Polit Sci* 2:493–535
- Ostrom E (2005) *Understanding institutional diversity*. Princeton University Press, Princeton
- Oxby C (2011) Will the 2010 'code pastoral' help herders in Central Niger? Land rights and land use strategies in the grasslands of Abalak and Dakoro departments. *Nomadic People* 15(2):53–81
- Rossi B (2002) *The Keita project: an anthropological study of international development discourses and practices in Niger*. Thesis submitted for the degree of Doctor of Philosophy in Social Anthropology, London School of Economics and Political Science. University of London

- Ruiz-Mallén I, Corbera E, Calvo-Boyero D, Reyes-García V (2015) Participatory scenarios to explore local adaptation to global change in biosphere reserves: experiences from Bolivia and Mexico. *Environ Sci Policy* 54:398–408. <https://doi.org/10.1016/j.envsci.2015.07.027>.
- Shanahan TM (2009) Atlantic forcing of persistent drought in West Africa. *Science* 324:377–380
- Snorek J, Rosenfeld T, Wirkus L, Renaud FG (2011) In-Depth assessment of selected policies in Niger. Climate Change, Hydroconflicts, and Human Security (CLICO) Project, Seventh Framework Programme, Brussels
- Snorek J, Renaud FG, Kloos J (2012) Case study protocol: Niger case study. A deliverable for the Climate Change, Hydro-conflict, and Human Security (CLICO) project
- Snorek J, Renaud F, Kloos J (2014a) Divergent adaptation to climate variability: an agro-pastoral case study from Niger. *Glob Environ Chang* 29:371–386
- Snorek J, Stark J, Terasawa K (2014b) Climate change and conflict in the Sahel: a policy brief on findings from Niger and Burkina Faso. U.S. Agency for International Development (USAID). January 2014
- Snorek J, Moser L, Renaud FG (2017) The production of contested landscapes: enclosing the pastoral commons in Niger. *J Rural Stud* 51:125–140. <https://doi.org/10.1016/j.jrurstud.2017.01.015>.
- Sovacool BK (2018) Bamboo beating bandits: conflict, inequality, and vulnerability in the political ecology of climate change adaptation in Bangladesh. *World Dev* 102:183–194. <https://doi.org/10.1016/j.worlddev.2017.10.014>
- Sovacool BK, Linnér B-O, Goodsite ME (2015) The political economy of climate adaptation. *Nat Clim Chang* 5:616–618
- The World Bank Group (2016) World Bank Data – Niger. Accessed 19 Aug 2015. <http://data.worldbank.org/country/niger>
- Touré O (2015) At the crossroads: analysing the impact of pastoral policies upon pastoralists based in Abalak, Niger. Tear fund Report. Accessed 1 Apr 2016. <https://landportal.info/news/2015/04/crossroads-analysing-impact-pastoral-policies-upon-pastoralists-based-abalak-niger>
- Vincent K (2007) Uncertainty in adaptive capacity and the importance of scale. *Glob Environ Chang* 17:12–24
- Zakara G, Abarchi H (2007) Assessment of the impacts of pastoral policies in Niger: Niger's experience in terms of national legislation enforcement for pastoralists' mobility and cattle circulation rights. World Initiative on Sustainable Pastoralism

**Open Access** This chapter is licensed under the terms of the Creative Commons Attribution 4.0 International License (<http://creativecommons.org/licenses/by/4.0/>), which permits use, sharing, adaptation, distribution and reproduction in any medium or format, as long as you give appropriate credit to the original author(s) and the source, provide a link to the Creative Commons license and indicate if changes were made.

The images or other third party material in this chapter are included in the chapter's Creative Commons license, unless indicated otherwise in a credit line to the material. If material is not included in the chapter's Creative Commons license and your intended use is not permitted by statutory regulation or exceeds the permitted use, you will need to obtain permission directly from the copyright holder.





# Climatepreneurship: Adaptation Strategy **105** for Climate Change Impacts on Rural Women Entrepreneurship Development in Nigeria

C. A. O. Akinbami

## Contents

Introduction .....	2144
Climate Adaptation Strategies Among Rural Women in Nigeria .....	2145
Climatepreneurship and Other Smart Strategies .....	2146
Theoretical and Conceptual Framework .....	2148
Theoretical Framework .....	2148
Conceptual Framework .....	2149
Methodology .....	2150
Data Analysis .....	2153
Result and Discussion .....	2153
Socio-Demographic Characteristics of Respondents .....	2153
Awareness of Climate Change and Impacts on the Business Activities .....	2153
Experiences of Participants and Their Livelihood Practices on the Effects of Climate Change .....	2156
Previous Intervention in the Two Communities .....	2157
Coping Strategies from Communities .....	2159
Climatepreneurship Intervention .....	2159
Effectiveness of Climatepreneurship Intervention .....	2160
Conclusion .....	2164
References .....	2166

---

This chapter was previously published non-open access with exclusive rights reserved by the Publisher. It has been changed retrospectively to open access under a CC BY 4.0 license and the copyright holder is “The Author(s)”. For further details, please see the license information at the end of the chapter.

---

C. A. O. Akinbami (✉)

Institute for Entrepreneurship and Development Studies, Obafemi Awolowo University, Ile Ife, Osun State, Nigeria

© The Author(s) 2021

W. Leal Filho et al. (eds.), *African Handbook of Climate Change Adaptation*,  
[https://doi.org/10.1007/978-3-030-45106-6\\_191](https://doi.org/10.1007/978-3-030-45106-6_191)

2143

---

**Abstract**

Adequate and proper adaptation strategies to climate change depend largely on activities in the rural sector, which drives national economy through exploitation of natural resources. Consequently, actions in rural areas are essential to successful climate change adaptation. Rural communities are highly dependent upon natural resources that are affected by climate change, thus affecting their food security, livelihoods, health, and physical infrastructure. Women and their livelihood practices are thereby affected negatively, leading to increased poverty level and low income, because they find it difficult to respond adequately to climate change effects. This study examines the past and existing interventions on climate change adaptation strategies in two rural communities in Oyo State, introduces climatepreneurship strategy, and assesses its effectiveness. This is an explorative study, employing qualitative approach to gather information through in-depth interview (IDIs) from 50 farmers, before and after the interventions. Data collected were analyzed using Atlas ti. This is a powerful workbench for qualitative data analysis using coding and annotating activities to generate different thematic issues for discussions and interpretations with networks. Study revealed that communities had previously experienced some interventions. Such had no impact on livelihood practices because steps to successful intervention were not followed. Socio-cultural practices hinder women development. The newly introduced climatepreneurship strategy improved livelihood practices. Study outcomes will expectedly be integrated into policy framework for sustainable rural women entrepreneurship development and also replicated in other rural areas in Nigeria.

---

**Keywords**

Climatepreneurship · Adaptation strategies · Climate change · Rural women · Entrepreneurship development · Nigeria

---

**Introduction**

In recent years, the terms viable adaptation strategies and climate resilience have become important concepts for both scholars and practitioners working on climate change. This progress reflects a growing interest from various disciplines in a holistic understanding of complex systems, including how societies interact with their environment and adapt to the increasing effects of climate change. This new lens offers an opportunity to focus on communities' ability to prepare for and adapt to the challenges posed by natural hazards and the mechanisms/strategies that have been developed to cope and adapt to threats. This is important because repeated stresses and shocks still cause serious damages to communities across the world, despite efforts to better prepare for disasters. This is especially relevant to the rural communities that are highly dependent upon natural resources which are affected by climate change, thereby affecting their economic activities, food security, livelihoods, health, and physical infrastructure.

Women in particular and their livelihood practices have become highly vulnerable. They face various challenges from effects of climate change such as drought, delayed rainfall pattern, heat wave, flood, etc. According to Howden et al. (2007), agriculture as a major economic, social, and cultural activity of most women, particularly in the rural areas, provides a wide range of ecosystem services. The sector is saddled with the responsibility of meeting the projected growth in human population and per capita food demand. Unfortunately, this sector remains highly sensitive to and affected by climate variations. The economic activities are therefore affected negatively, leading to increased poverty level and low income, because the rural women find it difficult to respond adequately to climate change effects.

Many studies have argued that climate change and its effects are clear, escalating and will continue to be a contending issue around the world, because enormous quantities of greenhouse gases (GHGs) have been released into the atmosphere over the past decades through anthropogenic activities (UNDP 2010; Adesina and Odekunle 2011; IPCC 2014, 2015; Salami 2010). According to Dube and Phiri (2013), climate change is now a well-accepted reality with emerging evidence that climate change poses a massive threat for development especially in poor countries. Also, Sadashivam (2010) reported that climate change is a global and regional environmental problem faced by humanity and livelihoods with strong implications for rural populations, particularly women. Kumar and Sharma (2013) analyzed the impact of climate change on agricultural productivity and submitted that variation in climate affects food grain and non-food grain productivity and other livelihood practices. This is due to the fact that climate change often alters the physical geography of an area leading to a disappearance or reduction of natural habitats that constitute the livelihoods of the women. Declining precipitation and rising temperatures are making farming increasingly more difficult with declining productivity, and thus aggravating food insecurity.

In Nigeria, Nwokeoma et al. (2017), Ikehi et al. (2014), Akinbami et al. (2015, 2019), and Ali (2011), have reported on the effects and social consequences of climate change on the farming families, livelihood practices, farmlands, economic activities, food security, health, and physical infrastructure in various communities in the country. These studies reveal that global warming which is as a result of climate change has serious impacts on the communities and their livelihood practices, and these effects will spiral out of control, if the current trend of increasing greenhouse gas emissions is not curbed. This will bring about more natural disasters, increased declining livelihood practices, worsened global food supply, and also threaten the existence of millions of people, with a disproportionately high impact on the impoverished and indigenous populations, particularly, the women. Therefore, there is a need to continue to pursue climate change mitigation and adaptation strategies with vigor (IPCC 2014).

---

## Climate Adaptation Strategies Among Rural Women in Nigeria

Some studies have documented various adaptation strategies geared toward economic development of women in Nigeria (Ikehi et al. 2014; Abid et al. 2015; Etim and Etim 2019) such as planting date adjustment, crop diversification, conservation

agriculture, and crop and livestock integration. However, according to Yilmaz (2014) and Etim and Etim (2019), many interventions have failed due to low awareness level and lack of proper involvement of stakeholders, inappropriate non-local technologies to the areas affected, and improper communication of interventions and implementation as the top-down approach was adopted, without the participation of community members. Howden et al. (2007) also alluded that there are many potential adaptation options available with substantial benefits only under moderate climate change for some cropping systems and are therefore not very effective under more severe climate change. In addition, most interventions lack long-term plan for monitoring and sustainability.

In order to build the resilience and sustainable development of women across the whole disaster cycle, involvement of communities in identifying problems (community communication) and involving them in addressing the identified problems become key factors to be considered in determining information-based adaptation strategies that are borne out of earlier sensitization programs. This is more of a bottom-up rather than top-down approach. It is believed that this approach will reduce the impacts of climate change as well as disaster-related losses and lead to faster recovery and the ability to “build back better” (Cutter et al. 2008).

Joo et al. (2011) further expatiated on steps that will aid sustainable development through implementation of interventions as (a) identifying key performance measure for the intervention by creating a plan to know the community to have an idea of their problem, attitude, and behavior; (b) measuring own’s internal performance level by how you have to be knowledgeable about the identified intervention and able to gather a team of experts to handle the identified problem and work on the actual and appropriate intervention; (c) identifying intervention advantages and disadvantages, process, and training models and materials; and (d) implementing intervention to close a performance gap by holding meetings and executing all the planning that have been done and importantly, follow through to achieve successful implementation which is monitored thereafter.

Therefore, in responding to the need of implementing appropriate measures to address the severity of climate-related hazards among Nigerian rural women, adequate and effective adaptation strategies are necessary to handle the effects of climate change. Such strategies will integrate the findings of climate change risk assessments into planning processes for disaster risk reduction and management and embrace methods that are climate smart and able to turn climate change challenges to entrepreneurship opportunities, thereby reducing poverty among the rural women, in particular, hence, the introduction of climatepreneurship.

---

## **Climatepreneurship and Other Smart Strategies**

In literature, scholars had conducted studies on smart strategies and termed differently, such as agri-preneurship, ecopreneurship, etc. Agri-preneurship, according to Ashe (2019), is a new measure taken by developing economies utilizing various forms of technological tools and methods to tackle farm yield, which is sometimes referred to as smart farming. Pai, Shah, and Bohara (2020) also stated that, as the



effects of climate change and population growth resulted in high food demand, smart farming is now being adopted. Agri-preneurship comprises of some farming methods such as geo-mapping, greenhouse farming, hydroponics, nutrient cycling, and soil analysis that could address the issue of low farm yield in developing economies (Ariani et al. 2018).

Ecopreneurship was seen as an answer to market breakdown in dealing with negative environmental impacts caused by the industries by focusing on underlying green values and solving the problems in the society caused by these businesses (Kirkwood and Walton 2010). That is, business activities should be geared toward providing values across three dimensions: economic, social, and environmental. Priority is given to addressing the effect of the negative externalities of firms' economic activities on these firms' immediate surroundings (Doman'ska et al. 2018). The goal is, therefore, to build a business model that is sustainable in the long run which ecopreneurship contributes to achieving this goal by seeking simultaneously for both profit and environmental sustainability (Rekik and Bergeron 2017). The concept of ecopreneurship is based on three pillars: innovation, caring for the environment, and long-term sustainability (Hultman et al. 2016).

Climatepreneurship is an adaptation strategy to climate change effects which consists of activities that are climate smart and make use of locally available resources for economic empowerment and enhancement of the social status of rural women. It also helps to turn climate change challenges into opportunities, and thereby emphasizes livelihoods' diversification. This concept entails climate change, adaptation strategies, and entrepreneurship, while according to Omodanisi et al. (2020), smart agri-preneurship entails smart agribusiness, smart technology, and entrepreneurship. Entrepreneurship in agri-preneurship is defined as the means to create and develop a profitable agribusiness, while in climatepreneurship, it is a means of turning climate change challenges into business ventures in all livelihood practices, as well as developing profitable agribusiness by adopting adaptation strategies. That is, agri-preneurship deals with ways of increasing farm yield, while climatepreneurship deals with climate-related issues as they affect the livelihood practices and more importantly, turning the challenges of climate change to various business ventures. On the other hand, ecopreneurship deals with the means of carrying out entrepreneurial activities in order not to affect the environment negatively.

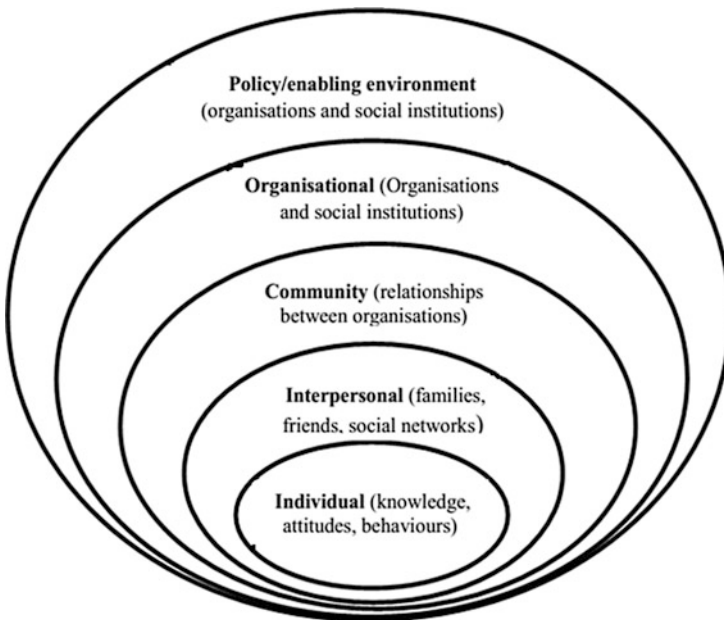
Though, the concepts are geared toward achieving sustainable development and reducing starvation among the populace, climatepreneurship goes a step higher by introducing livelihood diversification, exposure to the use of natural resources in the local environment, and turning climate change-related challenges into business opportunities as a major adaptation strategy (Rehman and Shaikh 2014; FAO 2011). Agri-preneurship can therefore be seen as a subset of climatepreneurship aimed at increasing farm yield and enhancing food security in an eco-friendly manner (FAO 2018; Lin et al. 2015; Omodanisi et al. 2020; Ponisio and Ehrlich 2018; Adebisi et al. 2018). Succinctly put, climatepreneurship is an adaptation strategy to climate change effects which consists of activities that are climate smart, eco-friendly process, and making use of locally available resources for economic empowerment and enhancement of the social status of rural women. It also helps to turn climate change challenges into opportunities.

Thus, climatepreneurship can be regarded as a viable and significant option to safeguard rural livelihoods and ensure rural sustainable development. Hence, this study on climatepreneurship, which presents viable adaptation strategy for addressing climate change, impacts women entrepreneurship development in Nigeria. It aims to examine the past and existing interventions and assess the effectiveness of implemented climatepreneurship strategy introduced by this study among rural women in selected communities in Oyo State.

## Theoretical and Conceptual Framework

### Theoretical Framework

This study is anchored on socio-ecological system approach which sees a community as a coherent system of biophysical and social factors that regularly interact in a resilient, sustained manner and are linked systems of people and nature, emphasizing that humans must be seen as a part of, not apart from, nature (Berkes and Folke 1998; Redman et al. 2004). The socio-ecological model (SEM), therefore, provides the framework for understanding the interactions between the multiple levels of a social system and how behavior and attitude are thereby affected. The multiple levels according to SEM are individual, interpersonal, community, organizational, and enabling environment (Fig. 1). The main tenant of this theory is based on



**Fig. 1** Socio-ecological theory. (Adapted from Bronfenbrenner (1989))

cooperation between individuals and environment within the system with emphasis on the model of communication for development (C4D), how to incorporate social norms and needs into program planning and partnerships to finally achieve capacity strengthening (CDC 2014).

Consequently, in this regard, adaptation strategies have been acknowledged as useful measurement to understand to what extent the intervention measures address the needs of people as end-users, to what conditions people are still vulnerable, whether the potential outcomes are expected or unwanted (MOVE D.5 2011; Yilmaz 2014). In this sense, it is important to monitor the effects of implemented strategies, especially in terms of observing how the affected communities adapt economically and socially.

### Conceptual Framework

The conceptual framework (Fig. 2) further explains the operationalization of the concepts in order to achieve positive results in the rural areas. The individual (rural woman) is the victim of climate change impacts, norms, and socio-cultural activities, and with low livelihood practice, who equally needs to change her own personal attitudes and beliefs toward climate change. Though, aware of the effects of climate change on her livelihoods but yet helpless because of the major and drastic changes

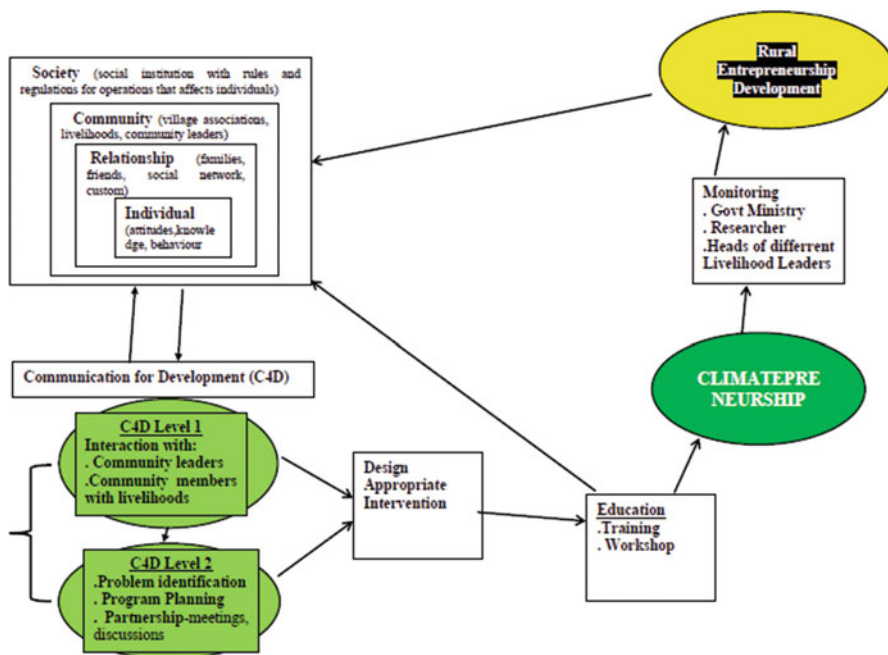


Fig. 2 Conceptual framework. (Source: Author)

in weather being experienced and leading to low farm yields and sales. Even though currently taking steps of engaging in moderate activities in order not to be idle, the poverty level is still on the increase. Having awaited help from government circle for so long, and now frustrated, the victim of the climate change impacts seeks for solution to the economic challenges. The community houses the relationships among institutions and informational networks within defined boundaries, which comprises of the total environment (social, economic, norms, and various association groups) as they affect the individuals reflecting gender specifics. The society at large dictates the enabling environment at the local, state, and national levels including policies that affect and regulate the choices the individual makes.

This framework underscores communication as a vital instrument for development, with the argument that livelihoods have been left to suffer as a result of non-involvement of the community members (i.e., partnership) in most of the interventions/programs that have at various times been designed for rural development. Consequently, the approach to the implementation of such programs had been top-bottom approach, and this has led to the failure of most of the interventions. If interactions through stakeholders meetings take place in order to identify actual problem and gain better understanding before planning a program, clarify limiting socio-cultural issues, designing appropriate training on handling and management of intervention, and establishing a monitoring team (as part of the monitoring and evaluation mechanism), then the designed program will definitely be successful, and the livelihoods of individuals will improve with poverty level reduced and eventually leading to sustainable development in the rural areas.

In essence, in order to reduce disaster and build resilient communities, the socio-ecological model should be an effective learning and assessment tool for the development of rural livelihoods. As the increasing new information and training on how to improve livelihood practices amidst impacts of climate change are gained, the employment of both bottom-top approach and partnership method will stir up a strong will among the rural dwellers to follow through with the new intervention (s) designed. The society and communities will directly be affected positively since both are collections of individuals.

---

## Methodology

This study was carried out to determine the extent to which adopted adaptation strategies to climate change have impacted on the rural women entrepreneurship development in Nigeria. An assessment study (Akinbami 2015) had been carried out to determine the impact of climate change on the livelihood practices of women in the rural areas of some southwest States of Nigeria. Due to limited fund available for the interventions in this study, Oyo State and some of the communities in the State were purposively chosen based on the assessment report on vegetation zone and availability of needed resources (Akinbami 2015) to pilot the implementation of the climatepreneurship strategy. This is an explorative study, employing qualitative

approach to gather information through in-depth interview (IDIs) and questionnaire administration from 50 farmers, both male and female, before and after the interventions. This study adopted descriptive research design to examine the past and existing interventions in the last few years before the introduction of climatepreneurship strategy. The study area is in Oyo State which is in the southwest region of Nigeria.

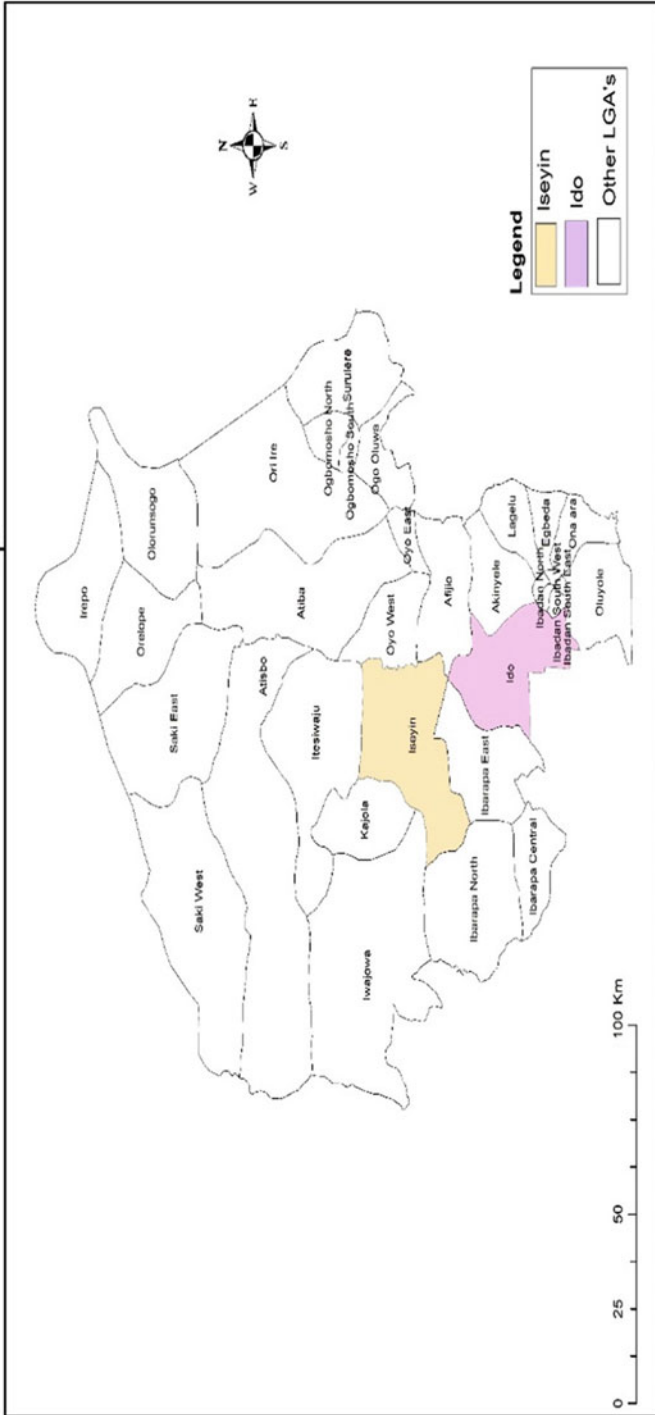
The study was carried out in two purposively selected communities – Araromi Idowu and Abokede Communities at Ido LGA, Ibadan, Oyo State, Nigeria (Fig. 3). The communities are made up of men and women whose different livelihood practices have been affected negatively by climate change. The target populations for this study are mostly women and few men involved in crop farming activities (cassava, maize, oil palm) and who were able to supply land space for planting. Pre-intervention interview was conducted only to participants who were able to supply up to an acre of land each. This was to capture necessary immediate situational experiences of the women and be able to compare with post-intervention interview.

Some men were also added for them not to view the project as just solely pro-women activity and a means of empowering the women against the men. This became useful in order to address the existing socio-cultural issues. The instrument for primary data collection was structured interview questions developed from literature reviewed for the study with inputs from the pre-intervention stakeholders meetings. The use of in-depth interview was to harvest the views and experiences of the respondents on the nature of perceived climate change impacts on their livelihood practices and previous interventions in their communities. The IDIs targeted participants who could provide up to an acre of land to accommodate intervention varieties, more for the purpose of monitoring and evaluation while the questionnaire was distributed among the other participants who showed interest in the intervention.

The project targeted 50 participants who had portions of land available and who were interested in participating.

The employed methodology involved some activities, such as:

- Community visitation and sensitization program.
- Meetings with different stakeholders in the communities to identify challenges.
- Distribution of improved drought-tolerant maize varieties and beta-carotene fortified cassava for planting.
- Distribution of hybrid oil palm trees (those who were able to supply up to an acre of land each) for planting,
- Training of women on entrepreneurship businesses in the oil palm tree products.
- Meetings with government parastatals saddled with women affairs, climate change, and agriculture in the State to intimate them with the objectives of the study and solicit their partnership and collaboration for its success.
- Facts finding workshop for all stakeholders involved in the study.
- Agricultural extension officers from the State Government were also part of the training exercise and workshop for effective monitoring of the intervention.



**Fig. 3** Map of Oyo State showing the Ido Local Government Area where the study areas are located

## Data Analysis

Data collected were analyzed using Atlas ti. This is a powerful workbench for qualitative data analysis using coding and annotating activities to generate different thematic issues for discussions and interpretations with networks.

---

## Result and Discussion

### Socio-Demographic Characteristics of Respondents

This section provides descriptive summary of the characteristics of the rural women and men entrepreneurs (18) gathered during IDIs, who were able to supply up to an acre of land each for the intervention in Table 1. However, the other 32 participants who showed interest in the exercise and with less than an acre of land were also accommodated by the intervention. The 18 participants reported in Table 1 were given drought-resistant maize, vitamin A-enhanced cassava, and hybrid oil palm trees. In addition, the intervention provided drought-resistant maize and vitamin A-enhanced cassava to the 32 participants (those with less than 1 acre of land) for planting on their farming space.

All the 18 participants were in the age range of 40–65 years (Table 1). Participants were mainly into crop farming involving planting of maize grains, cassava, and palm tree. All of the women were found to be involved in another occupation, such as food processing of garri (cassava-based Nigerian staple food); cassava and palm oil ventures; and sales of cloths, beverages, and other food items. While all the men had crop farming as their major economic activity, about 67% were not involved in any other economic activity. The table further revealed that about 20% of the men were into additional occupation of commercial transportation using their motor cycles, and it was observed that these are of the younger generation. About 10% of the men were involved in food processing as an additional economic activity.

Table 1 also showed their educational status; about 72% of the participants were not with formal education, 22% had only primary school education, and 6% were with secondary school education. About 96% of the participants had spent more than 15 years in crop farming business.

The age range of the other 32 participants is between 38 and 65 years, with 80% being women involved mostly in food processing, while the men (20%) were mainly into crop farming. It was observed that the educational status, awareness of climate change, and involvement in other occupational activities are the same as those respondents in IDI. The opinions of the respondents in both instruments are presented in the analysis.

### Awareness of Climate Change and Impacts on the Business Activities

All the respondents (from IDIs and questionnaire) reported that they are aware of the changes in the weather recently. The participants stated that the changes had been

**Table 1** Socio-demographic factors of participants during IDIs

Respondent	Age	Sex	Educational status	Occupation	Community	Years of farming engagement	Second occupation
Respondent 1	40	Female	Secondary	Crop farming	Abokede	5	Sales of provision
Respondent 2	60	Female	No formal education	Crop farming	Abokede	30	Sales of cloth
Respondent 3	50	Female	No formal education	Crop farming	Abokede	25+	Food processing (palm oil)
Respondent 4	40	Female	No formal education	Crop farming	Abokede	20	Food processing (palm oil, cassava)
Respondent 5	65	Female	No formal education	Crop farming	Abokede	30+	Food processing (palm oil)
Respondent 6	50	Female	Primary education	Crop farming	Abokede	20+	Sales of yam flour
Respondent 7	40	Male	Primary education	Crop farming	Araromi-Idowu	15	Commercial motor cycling
Respondent 8	52	Male	Primary education	Crop farming	Abokede	30+	None
Respondent 9	60+	Male	No formal education	Crop farming	Abokede	30+	None
Respondent 10	62	Male	No formal education	Crop farming	Abokede	30+	None
Respondent 11	55	Female	No formal education	Crop farming	Abokede	20	Food processing (palm oil)
Respondent 12	62	Female	No formal education	Crop farming	Abokede	20	Food processing (palm oil)
Respondent 13	42	Male	No formal education	Crop farming	Araromi-Idowu	30+	Commercial motor cycling
Respondent 14	57	Male	No formal education	Crop farming	Abokede	30+	None
Respondent 15	60	Female	No formal education	Crop farming	Araromi-Idowu	30+	Sales of dry maize
Respondent 16	50	Male	No formal education	Crop farming	Abokede	30+	None
Respondent 17	56	Male	No formal education	Crop farming	Abokede	30+	Food processing (palm oil)
Respondent 18	48	Male	Primary education	Crop farming	Araromi-Idowu	30+	None

Source: Study Survey



observed through personal experiences and comments from colleagues as far back as 30 years' ago, and this has been confirmed by information from the radio programs they listened to on climate change. Their awareness cut across the elements of weather vagaries such as distortion of rainfall pattern, drought, sea level rise, temperature rise, and increase in humidity. They reported "as farmers, we have experienced hard times as a result of the changes, which ranges from delayed rainfall to increase in temperature and drought." Consequently, the communities have suffered some economic hardship and social consequences from impacts of climate change. Some of the responses of the respondents are:

There is too much heat, as a result, our crops, vegetables and other things planted do not do well. Sometimes, the farm products harvested are both too few in quantity and small in size that we do not have good quality crops to sell. This has increased poverty level in this community, especially among the women. **Female Participant, Abokede Community, 40 years old**

The weather has become so unfriendly, we as farmers do not have rains as at when due, the sun is too much, our crops therefore produce low yield. Ultimately, we have little to sell and are having poverty increasing in this community. **Male Participant, Araromi-Idowu Community, 42 years old**

This study outcome supports the work of Suleiman (2014) which stated that farmers had crops uprooted prematurely and destroyed due to harsh weather condition; as such, crops could not be taken to the market. They lost money that should have been gained.

This could be the reason why the younger-generation men in this study subscribed to another business (commercial transportation) because the pangs of impacts of climate change were being felt. The income generated from only farming activity was no longer enough to cater for their needs. These impacts had led to the increase of poverty level in the communities and particularly, among the women. It has further shown the relationship between climate change, livelihood practices, and community empowerment.

Also, due to the low level of education of the rural communities, participants could not process the information received into finding out the causes of climate change and what adjustments are needed to be made to improve the livelihood practices. Participants knew nothing about crop diversification strategy which could have helped to improve the livelihood practices. This study revealed the communication gap that exists between the rural areas and research outcomes. This submission is in line with FMENV (2010) which stated that programs, policies, and activities of the Ministry on climate change do not seem to have specifically targeted and involved farmers. Consequently, the farmers are exposed to hardship. In affirmation, participants from both communities stated:

We are hoping that help will come one day. Our community leaders know about our plight since we are in it together, unfortunately, they don't know what to do. **Female Participant, Araromi-Idowu Community, 62 years old**

We don't even know the cause of the change nor do we know the solution. **Male Participant, Abokede Community, 57 years old**

Participants could not produce any observed weather pattern based on the reported climate change, to help them know when and what to plant, that is, adjusting the planting calendar in order to adapt to the change in rainfall pattern, as stated by Ikehi et al. (2014) that “planting date adjustment” is one of the strategies that can be employed by the rural communities to cope with impacts of climate change. The study is also of the opinion that the low level of education of the participants may be a major factor responsible for this inability.

Participants declared that they have been coping through prayers. They perceived climate change as an act of God and not induced by the activities of man. They also said God has decided to punish man as a result of sin which is on the increase daily. This has affected their readiness and preparedness for mitigation and adaptation strategies. A participant said:

Sacrifices were done by our forefathers with animals and now are being done with human beings, so, why will God not be angry. **Male Participant, Araromi-Idowu Community, 62 years old**

The participants’ lack of understanding therefore calls for urgent and proper training at the rural areas by the agriculture extension officers, so that rural dwellers especially will not continue waiting for the government to handle what they can quickly put right by themselves. This study sees this step as important because an enlightened community will be able to contribute to the process of developing adequate adaptation strategies which the community will own and preserve. Consequently, intensive and extensive sensitization and education programs mounted by both public and private sectors including the faith and community-based organizations as well as climate-based NGOs are essential since effective adaptation requires a holistic approach that incorporates both policy, people, and investment issues into the planning and decision-making processes. This is of great importance as no one solution will adequately address effective adaptation in all communities (UNDP 2010). Effective adaptation will require long-term planning approaches at the national, regional, and also, local level, which is responsible for the national food supply. However, at all the levels, their associated impacts in the rural communities may not succeed if the end users are not carried along due to the lack of understanding of subject matter.

## **Experiences of Participants and Their Livelihood Practices on the Effects of Climate Change**

The study revealed some of the experiences of participants from the effects of climate change as it affects their livelihood practices. According to the participants, the climatic change ranges from delayed rainfall, strong wind, increase in temperature, and heavy rainfall leading to flooding, thereby affecting the roads and also resulting in overflowed rivers. It was observed that participants from the two communities have similar experiences as they commented on the effects of different aspects of climate change. It was reported that there has been delayed occurrence of

rainfall, and when it occurs, the intensity was unusually heavy and had an adverse effect on their farm products. This was reported by participants during the in-depth interview sessions and questionnaire administration conducted in the two communities. The reported effects of climate change on the participants' crop farming business are presented in Fig. 4. According to Akinbami et al. (2019) and Slater et al. (2007), these negative impacts have implications on food security of the nation. As a nation, researchers, civil society, and policy makers should be in quest for innovative approaches to food security and not depleting the available quantity, especially with population increase which may expose people to the risk of hunger and its associated social vices.

### Previous Intervention in the Two Communities

According to some of the participants from Araromi-Idowu and Abokede communities, it was reported that they have never been part of any intervention either from the government, NGO, or a researcher. The community leader at Araromi-Idowu reported that there has not been specific intervention from the government except for a borehole that was dug for the community about 3 years ago. The borehole has ceased functioning due to lack of electricity to pump constantly. However, he further stated that some researchers in the last 2 years had visited the communities with some interventions. He retorted:

About two different times, some people (researchers) visited our community and distributed cassava stem (they said it is fortified with vitamin A) and maize grains to few male farmers. We were not taught the importance of the seedling and grains. As a result, most of us did not plant them. I kept the grains in my house and I know that my colleagues did same. **Youth Community Leader, Araromi-Idowu Community**

From the submission of the respondents, it was observed that interventions did not succeed because the measures that lead to successful implementation of interventions were not taken into consideration. Measures such as communication and partnership with the communities' members, as well as monitoring, were missing (Joo et al. 2011; CDC 2014; Yilmaz 2014; Etim and Etim 2019). Apart from the ineffectiveness of the previous interventions, the women reported special challenge they are facing as a result of socio-cultural practices which are still very strong in the rural areas.

About three years ago, some people came to train us women on how to manage our businesses, the men did not allow us to participate fully. They felt threatened and it is also against the rules/practices of this community to gather only the women. The cause of their anxiety is that they thought we would be exposed to things that will make us rebel against them, especially, when we are financially liberated. **General response from women in the two communities**

This study is of the opinion that these unattended to changes in weather patterns through various appropriate and effective adaptation and mitigation measures will

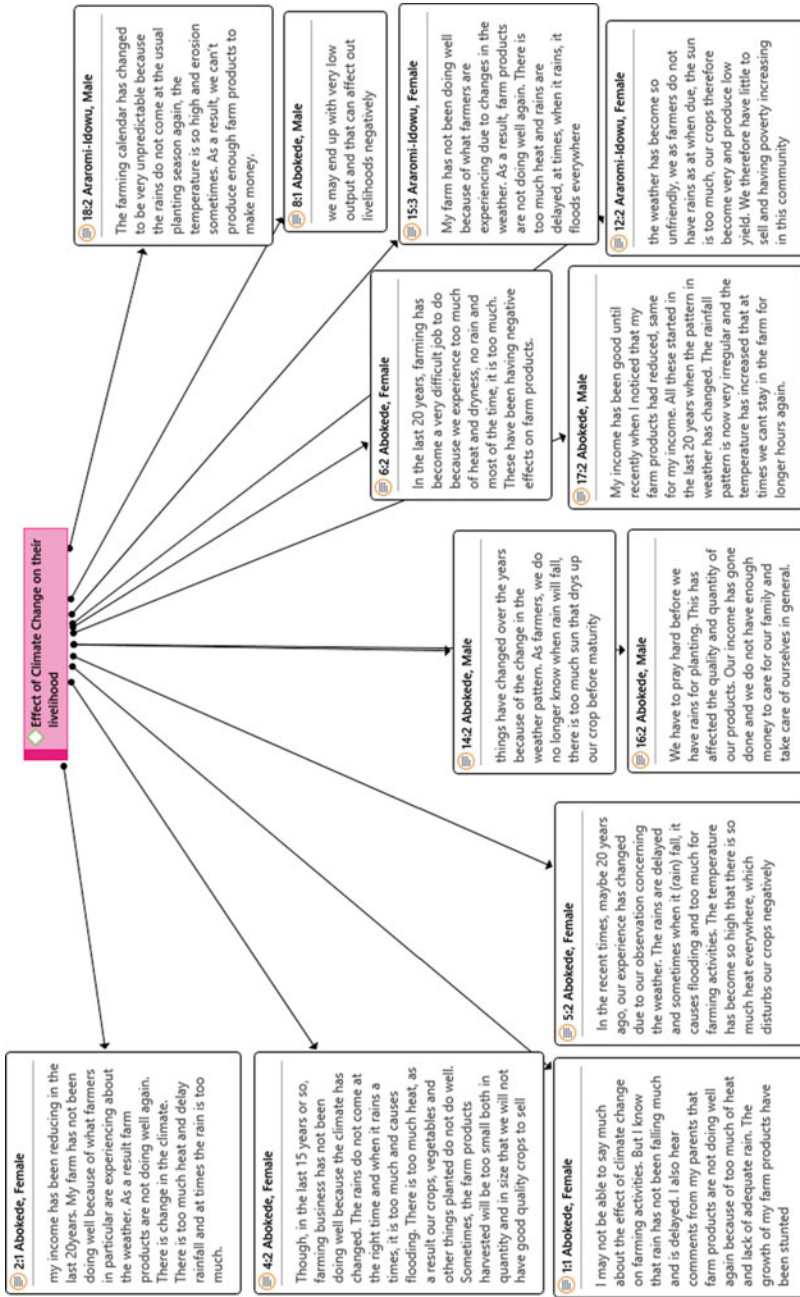


Fig. 4 Effects of climate change on participants' livelihood

result in increasing series of devastating natural disasters and low economic activities and poverty level in the rural areas. Consequently, more people will continue to abandon rural areas that are strongly affected by climate change and migrate to cities. Furthermore, extreme weather events such as floods and heat waves can also pose significant health threats such as diarrheal disease, dehydration, or cardiac complications, and mean temperature changes can alter the range and transmission potential of diseases such as malaria (Akinbami and Momodu 2013, GIZ and MoEF 2009).

## **Coping Strategies from Communities**

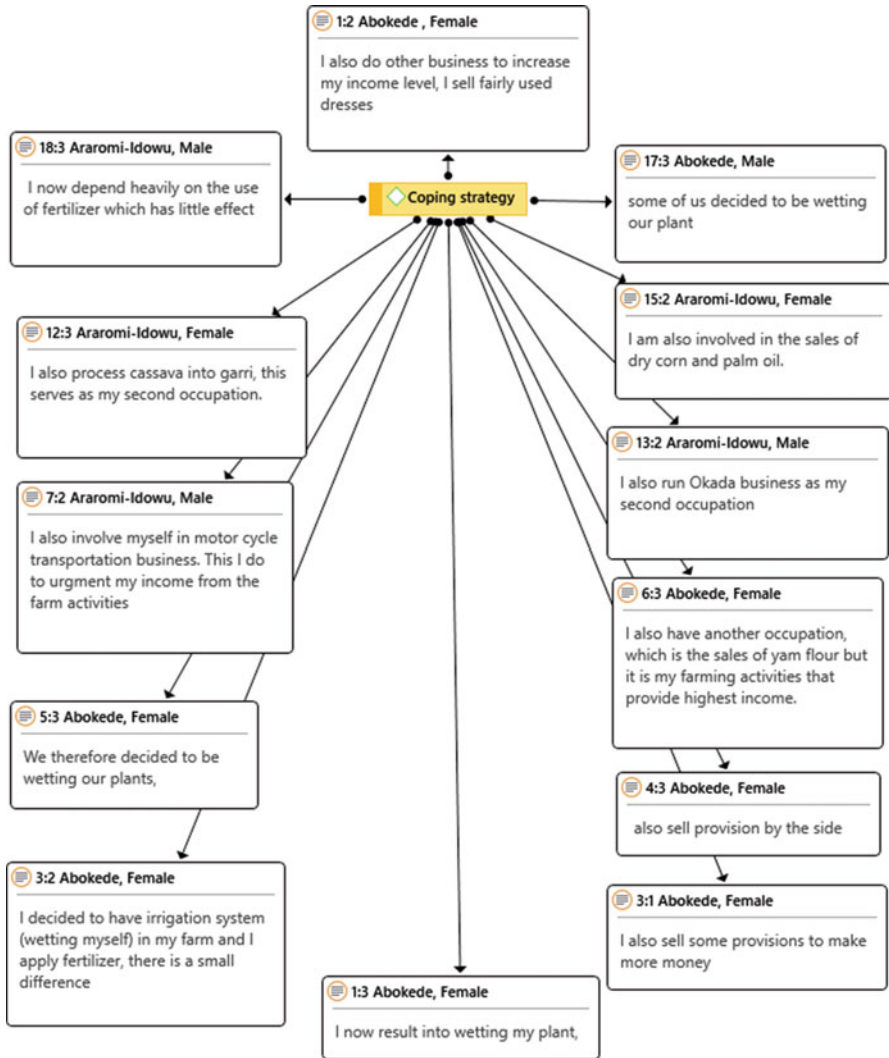
During the interview conducted, participants revealed that they have employed some strategies such as diversifying into other business line, use of fertilizer, and wetting of plants from nearby river. It was observed that all of the women and just a few of the men were involved in business diversification. This finding agrees with WEDO (2007) that stated that women have developed specific adaptive strategies to cope with climate change-induced problems in livelihood, health, shelter, energy sectors, etc. in some countries. This suggests that women, if exposed to the right training, can employ their initiatives to develop strategies that will help handle immediate and long-term strategies that will gradually reduce the impacts of climate change in the rural areas. Figure 5 presents various coping strategies the women and some men in the communities visited adopted to alleviate the sufferings associated with effects of climate change. The figure depicts the readiness and willingness of the rural women.

However, the women reported that the socio-cultural climate of their communities hinders their ability to cope. Firstly, the practice around land tenure which prevents women from owning land hinders their ability to diversify. This was well experienced in Araromi-Idowu where the community missed out of oil palm intervention due to lack of land and strong existence of patriarchal system in place.

## **Climatepreneurship Intervention**

The climatepreneurship intervention provided a template which would improve the coping strategies of the participants. Climatepreneurship intervention also exposed participants to the use of natural resources in their community that can be turned to various business activities, such as clay work. This became necessary, in order to create avenues to increase their income generation activities. Also, they were trained on entrepreneurship businesses in the oil palm tree products, such as basket weaving. This was with the aim of introducing them to business diversification concepts.

In order to strengthen participants' coping strategies through proper monitoring, the researcher held series of meetings with the government parastatals in charge of women, community development, and extension officers. This was to enable them get proper understanding of climatepreneurship concept and see to the success and continuity of the intervention through its replication in other communities.



**Fig. 5** Coping strategies employed by participants in both Araromi-Idowu and Abokede communities

### Effectiveness of Climatepreneurship Intervention

Climatepreneurship was designed by the researcher as an adaptation strategy intervention by employing the opportunities that climate change present to enhance entrepreneurship growth and development for the economic empowerment of the rural men and women. It provided some climate smart grains and seedlings to participants of Araromi-Idowu and Abokede communities in order to empower the women in the communities by helping them to have their livelihood practices

improved. This intervention employed some methods that led to its success. Some outcomes were observed as a result of the activities employed by climatepreneurship intervention to demonstrate community communication, partnerships, and bottom-up approach, in order to strengthen their economic capacity and increase entrepreneurship development. These outcomes include:

- The actual needs of participants were known such as lack of monitoring from agricultural extension officers.
- Actual impacts of climate change on their livelihood were stated.
- The drought-resistant maize grains, hybrid oil palm seedlings, and vitamin A-enhanced cassava stems were identified to improve their livelihood practices, thereby enhancing entrepreneurship development and economic empowerment.

The basic and fundamental step was to enlist their interest that led to the acceptance of intervention by community leaders and members. Training sessions were organized in the two communities to educate participants on the handling and management of grains and seedlings. Thereafter, drought-tolerant maize grain varieties, beta-carotene fortified cassava stems, and hybrid oil palm seedlings were distributed to participants and were planted as revealed in Fig. 6. Monitoring tool was employed via periodic visitation to communities and the involvement of the government parastatal attached to agriculture services in the state.

Participants retorted that they have never planted such improved and enhanced seedling varieties before climatepreneurship intervention, though, most of the participants claimed that they have heard of their existence through friends and neighboring communities.

Post-intervention interview was conducted when the drought-tolerant maize grain varieties and beta-carotene cassava stems planted were matured for harvesting, and the participants were able to express their experiences. All the farmers attested to the effectiveness of this intervention over the local maize grains they were used to. Some of the participants from the two communities reported their experiences with climatepreneurship as evidence to its effectiveness and said:

We have not seen this before. It seems we are going back to those days when farming was rewarding. The maize harvested is quite different from the local grains we normally planted. This one got matured before it was normal 3 months, which means we farmers will have more to sell and thereby have more money to cater for ourselves. It is also sweeter in taste than the one we were used to. What really gladdens my heart is that we will have more trips to the market from the look of things. I will distribute the grains to other people in this community, so that we can all have access to this new grain. **Male Participant, Araromi-Idowu Community, 48 years old**

I never knew the outcome will be this fantastic. We were mocked by some of our colleagues in this community because there was not enough rains. They were so sure that we were wasting our time, despite the training we had before the grains were handed over to us. Maybe, if the researcher had handed the grains over to us without staying on the farm with us to plant every grain, I would have just gone to keep the grains also. But now, I thank God that I participated. Our people that mocked us then are now asking for the grains. I am preparing for good sales this season. **Female Participant, Abokede Community, 50 years old**



Female and male farmers planting drought tolerant maize grains and beta-carotene fortified cassava seedlings



Group of male and female farmers with hybrid oil palm Female farmer planting hybrid oil palm



Distribution of Beta-carotene fortified cassava Both farmers planting drought tolerant maize

**Fig. 6** Participants with climate-smart grains and seedlings

The cassava stem planted yielded so well. Apart from the fact that the tubers are big, I now have cassava that can also improve our health. In this community, we eat a lot of cassava and we process it to fufu (staple food made from cassava) which we take to the city to sell. So apart from having more quantities to sell for money, we are also contributing to the well being of people. I know that we will always have this in this community now by replanting the stem. **Female Participant, Araromi-Idowu Community, 62 years old**

From Fig. 7, it is evident that the rural areas are ready for innovative adaptation strategies, if the right investment is made.

To further enhance the effectiveness of this intervention and strengthen the capacity of participants, it was observed during the pre-intervention activities that





**Fig. 7** Post-intervention measure pictures showing harvested maize and cassava in the two communities



**Fig. 8** A dug well for improved economic activities by the intervention

the communities lack good clean water supply for the processing of the harvested cassava into fufu (a Nigerian staple food), a well was also dug in the communities to improve their economic activities and their health status because this well water will be used for drinking purposes as well by the communities (see Fig. 8). Unlike the previous intervention of a borehole that was dug by the government which ceased functioning due to the lack of electricity to pump water constantly, the well was made people-friendly which even a young boy or girl would constantly be able to operate manually at any time.

However, in spite of the success of the various aspects of the climatepreneurship intervention measures, the hybrid oil palm aspect was not as successful as others. This is mainly due to the existing land tenure and strong patriarchal system in place in the communities. Since the condition for eligibility for the hybrid oil palm was access to at least 1 acre of land so that the quantity to be harvested would have a positive impact on economic status of the women, most of the women jointly contributed land to be eligible. Also, unfortunately, the community experienced clash between herdsmen and farmers. It was later observed in between the periodical monitoring of the project that cattle rearers had led cattle to the oil palm farm, which was not close to farmers' dwelling places and devastated some of the seedling planted, thereby defeating the objective of this part of the project.

---

## Conclusion

Adapting to climate change represents a new challenge particularly in the rural areas. Already, linkages exist between business-as-usual development strategies and adaptation to climate change impacts. Therefore, development strategies that will

generate benefits for managing climate change risks are highly essential. Such will result in poverty reduction, improved nutrition, enhanced education, expanded infrastructure, and improved health which will also reduce vulnerability to climate change and enhance wellness.

This study presented available adaptation strategies suggested by various authors for testing of conformity with rural farmers, following the view that environmental knowledge and resilience to climate change lay within societies and cultures. Farmers in these communities of study have experienced hard times as a result of climate change effects ranging from delayed rainfall, heavy rainfall which lead to flooding, increase in temperature, and drought. Consequently, the communities have suffered some economic hardship and social consequences from impacts of climate change. This necessitates the rural dwellers diversification and integration of other livelihood practices in addition to crop farming. Observations made in the communities of study agreed with previous studies such as Suleiman (2014) and Yusuf et al. (2017).

Due to the low level of education of the rural communities, participants could not process the information received into finding out the causes of climate change and what steps to take to abate the climate change impacts and improve their livelihood practices. It is therefore essential that intensive and extensive sensitization and comprehensive education programs mounted by both public and private sectors including the faith and community-based organizations as well as climate-based NGOs be incorporated into the development intervention strategies in the rural communities in their various local languages for effective and benefitting communication. For example, such sensitization and education programs may include the production of facts sheet and radio interactive programs specifically tailored to address rural farmers' challenges.

Innovative adaptation strategies such as climatepreneurship which consists of activities that are climate smart and make use of locally available resources for economic empowerment and enhancement of the social status of rural women and also help to turn climate change challenges into opportunities have been assessed as effective intervention measures in rural communities. It therefore reveals that successful climatepreneurship intervention measure entails a bottom-up approach that requires a situational report of rural communities for a good understanding of the peculiarities of their climate and environmental assessment based on vegetation zones in each geopolitical zone in the country, as well as locally available raw materials that can be turned to sustainable economic empowerment ventures. These will help to forestall the increasing rural-urban migration with its attendant food insecurity and social vices and further help in developing the rural dwellers especially the womenfolk through sustainable economic empowerment and also enhancing their socio-political status in the society. Ultimately, many more micro-, small-, and medium-sized enterprises (MSME) can begin springing up and thereby enhancing environmentally sustainable industrial rural development and increasing economic value additions to both sub-national and national economic growth and development.

The paper concludes that the purpose of undertaking adaptation strategy is to effectively manage potential climate risks over the coming decades as the effects of

climate change continue to increase because such can help inform decisions by farmers (both women and men), agribusiness owners, policy makers, and development partners of implications over a range of timeframes from short-term tactical to long-term strategic options. This is because inadequate consideration of and in-appropriate actions to adaptation options could result in increased vulnerability to climate change generally in the rural areas and particularly by women and children, and thereby giving rise to more severe mitigation targets and costs.

**Acknowledgments** This research was supported by funding from the Department for International Development (DfID) under the Climate Impact Research Capacity and Leadership Enhancement (CIRCLE) program.

---

## References

- Abid M, Scheffran J, Schneider UA, Ashfaq M (2015) Farmers perceptions of and adaptation strategies to climate change and their determinants: the case of Punjab Province, Pakistan. *Earth Syst Dyn* 6(1):225–243
- Adebisi OA, Adeola AT, Osinowo OA, Brown D, Ng'Ambi JW (2018) Effects of feeding hydroponics maize fodder on performance and nutrient digestibility of weaned pigs. *Appl Ecol Environ Res* 16(3):2415–2422
- Adesina FA, Odekunle TO (2011) Climate change and adaptation in Nigeria: some background to Nigeria's response – III. International conference on environmental and agriculture engineering IPCBEE, vol 15. IACSIT Press, Singapore
- Akinbami CAO (2015) Assessment of social dimensions of climate change on Nigerian rural women livelihood practices: implication for entrepreneurship development. Unpublished post-doctoral fellowship report for African Academy of Sciences, Nairobi
- Akinbami CAO, Momodu AS (2013) Health and environmental implications of rural female entrepreneurship practices in Osun state Nigeria. *AMBIO J Hum Environ*. <https://doi.org/10.1007/s13280-012-0355-5>
- Akinbami CAO, Olawoye JO, Adesina FA (2015) Chapter 4: Rural women belief system and attitude toward climate change mitigation and adaptation strategies in Nigeria. In: Walter LO et al (eds) *Climate change adaptation, resilience and hazards*. Springer Nature, Springer International Publishing AG Switzerland, pp 49–69. <https://doi.org/10.1007/978-3-319-39880-8>
- Akinbami CAO, Olawoye JO, Adesina FA, Nelson V (2019) Exploring potential climate related entrepreneurship opportunities and challenges for rural Nigerian women. *J Glob Entrep Res* 9:19. <https://doi.org/10.1186/s40497-018-0141-3>
- Ali YO (2011) Legal profession and climate change in Nigeria. [http://www.yusufali.net/articles/LEGAL\\_PROFESSION\\_CLIMATE\\_CHANGE\\_IN\\_NIGERIA](http://www.yusufali.net/articles/LEGAL_PROFESSION_CLIMATE_CHANGE_IN_NIGERIA). Accessed 23 Sept 2019
- Ariani M, Hervani A, Setyanto P (2018) Climate smart agriculture to increase productivity and reduce greenhouse gas emission– a preliminary study. *IOP Conf Ser Earth Environ Sci* 200(8):12–24
- Ashe MO (2019) International agencies and the quest for food security in Nigeria, 1970–2015. *Ubuntu J Confl Transform* 8(Special Issue 1):251–274
- Berkes F, Folke C (eds) (1998) *Linking social and ecological systems: management practices and social mechanisms for building resilience*. Cambridge University Press, New York
- Bronfenbrenner U (1989) Ecological systems theory. In: Vasta R (ed) *Annals of child development*, vol 6. Jessica Kingsley, London, pp 187–249
- Centers for Disease Control and Prevention (CDC) (2014) The social ecological model: a framework for prevention. <http://www.cdc.gov/violenceprevention/overview/social-ecologicalmodel.html>. Retrieved 21 Apr 2014

- Cutter SL, Barnes L, Berry M, Burton C (2008) A place-based model for understanding community resilience to natural disasters. *Global Environ Chang* 18:598–606. <https://doi.org/10.1016/j.gloenvcha>
- Doman'ska A, Z'ukowska B, Zajkowski R (2018) Green entrepreneurship as a connector among social, environmental and economic pillars of sustainable development. Why some countries are more agile? *Probl Ekorożwoju* 13:67–76
- Dube T, Phiri K (2013) Rural livelihoods under stress: the impact of climate change on livelihoods in South Western Zimbabwe. *Am Int J Contemp Res* 3(5):11–25
- Etim NA, Etim NN (2019) Rural farmers' adaptation decision to climate change in Niger Delta region, Nigeria. In: *Handbook of climate change resilience*. pp 1035–1049. Springer, Cham. [https://doi.org/10.1007/978-3-319-93336-8\\_100](https://doi.org/10.1007/978-3-319-93336-8_100)
- FAO (2011) The global bioenergy partnership sustainability indicators for bioenergy. GBEP
- FAO (2018) Climate-smart agriculture. Food and Agriculture Organization of the United Nations
- Federal Ministry of Environment of Nigeria (2010) Climate change. Available at <http://environment.gov.ng/issues/climate-change/> (accessed on March 12, 2012)
- GIZ, MoEF (2009) Adaptation to climate change with a focus on rural areas and India. A publication of German development cooperation institution Deutsche Gesellschaft für Internationale Zusammenarbeit (GIZ) GmbH and Ministry of Environment and Forests (MoEF), Government of India
- Howden SM, Soussana JF, Tubiello FN, Chhetri N, Dunlop M, Meinke H (2007) Adapting agriculture to climate change. *PNAS* 104(50):19691–19696. [www.pnas.org/cgi/doi/10.1073/pnas.0701890104](http://www.pnas.org/cgi/doi/10.1073/pnas.0701890104)
- Hultman M, Bonnedahl KJ, O'Neill KJ (2016) Unsustainable societies – sustainable businesses? Introduction to special issue of small enterprise research on transitional Ecopreneurs. *Small Enterp Res* 23:1–9
- Ikehi ME, Onu FM, Ifeanyiye FO, Paradang PS (2014) Farming families and climate change issues in Niger Delta region of Nigeria: extent of impact and adaptation strategies. *Agric Sci* 5:1140–1151. <https://doi.org/10.4236/as.2014.512124>. Scientific Research. <http://www.scirp.org/journal/as>
- Intergovernmental Panel on Climate Change (IPCC) (2015). <http://www.ipcc.ch>
- IPCC (2014) Climate change 2017: impacts, adaptation, and vulnerability, contribution of working group II to the fourth assessment report of the Intergovernmental Panel on Climate Change. Cambridge, UK
- Joo SJ, Nixon D, Stoerber PA (2011) Benchmarking with data envelopment analysis: a return on asset perspective. *BIJ* 18(4):529–542. <https://doi.org/10.1108/15635771111147623>
- Kirkwood J, Walton Y (2010) What motivates ecopreneurs to start businesses? *Int J Entrep Behav Res* 16(3):204–228
- Kumar A, Sharma P (2013) Impact of climate variation on agricultural productivity and food security in rural India. Discussion paper, No. 2013-43|August 21, 2013. <http://www.economics-ejournal.org/economics/discussionpapers/2013-43>
- Lin TC, Shaner PJ, Wang LJ, Shih YT, Wang CP, Huang GH, Huang JC (2015) Effects of mountain tea plantations on nutrient cycling at upstream watersheds. *Hydrology and Earth System Sciences* 19(11):4493–4504
- MOVE D.5 (2011) D 5. Generic conceptual framework for vulnerability measurement, Methods for the improvement of Vulnerability Assessment in Europe, EUROPEAN COMMISSION DG ENVIRONMENT
- Nwokeoma BN, Amad K, Chinedu AK (2017) Climate variability and consequences for crime, insurgency in North East Nigeria. *Mediterr J Soc Sci* 8(3):171. <https://doi.org/10.5901/mjss.2017>. MCSER Publishing, Rome-Italy
- Omodanisi EO, Egwakhe AJ, Ajike EO (2020) Smart agri-preneurship and farm yield in Nigeria. *Global Sci J* 8(3):1722–1740. ISSN 2320-9186
- Pai A, Shah S, Bohara R (2020) Smart agriculture (No. 2699). EasyChair
- Poniso LC, Ehrlich PR (2018) Diversification, yield and a new agricultural revolution: Problems and prospects. *Sustainability* 8(11):1118
- Redman C, Grove MJ, Kuby L (2004) Integrating social science into the long term ecological research (LTER) network: social dimensions of ecological change and ecological dimensions of social change. *Ecosystems* 7(2):161–171

- Rehman A, Shaikh S (2014) Smart agriculture. *Int J Commun Netw Inf Secur* 32(2):263–270
- Rekik L, Bergeron F (2017) Green practice motivators and performance in SMEs: a qualitative comparative analysis. *J Small Bus Strateg* 27:1–18
- Sadashivam T (2010) Climate change and rural development: the challenges for agricultural dynamics. *Int J Rural Stud (IJRS)* 17(2). ISSN 1023–2001. [www.vri-online.org.uk/ijrs](http://www.vri-online.org.uk/ijrs)
- Salami A (2010) Climate change mitigation and adaptation options: the Nigeria experience. Available: <http://www.spaeloauife.net/develoing.html>
- Slater R, Peskett L, Ludi E, Brown D (2007) Climate change, agricultural policy and poverty reduction – How much do we know? *Natural Resources Perspectives*, September, 2007. UK: Overseas Development Institute. ISSN 1356–9228
- Suleiman IL (2014) Appraisal of climate change and agriculture in Nigeria. *J Geogr Reg Plan* 7(9):176–184. <https://doi.org/10.5897/JGRP2013.0405>
- UNDP (2010) Designing climate change adaptation initiatives: a UNDP toolkit for practitioners. UNDP Bureau for Development Policy. UNDP, New York
- Women’s Environment & Development Organization (2007) *Changing the climate: why women’s perspectives matter*. WEDO, New York
- Yilmaz DG (2014) Adaptation of rural communities and understanding their socioeconomic vulnerability for future. 4th international conference on building resilience, building resilience 2014, 8–10 September 2014, Salford Quays, United Kingdom. *Procedia Econ Finance* 18:536–543
- Yusuf OJ, Ayanda IF, Olooto FM, Salawu OL (2017) Livelihood diversification amongst pastoralists and conflict with Arable crop farmers: empirical evidence from Kwara state, Nigeria. *Nigerian Journal of Rural Sociology* 17(1):45–53

**Open Access** This chapter is licensed under the terms of the Creative Commons Attribution 4.0 International License (<http://creativecommons.org/licenses/by/4.0/>), which permits use, sharing, adaptation, distribution and reproduction in any medium or format, as long as you give appropriate credit to the original author(s) and the source, provide a link to the Creative Commons license and indicate if changes were made.

The images or other third party material in this chapter are included in the chapter’s Creative Commons license, unless indicated otherwise in a credit line to the material. If material is not included in the chapter’s Creative Commons license and your intended use is not permitted by statutory regulation or exceeds the permitted use, you will need to obtain permission directly from the copyright holder.





# Intersectional Perspective of Strengthening Climate Change Adaptation of Agrarian Women in Cameroon

# 106

Faith Ngum and Johan Bastiaensen

## Contents

Introduction .....	2170
Conceptual Framework: Intersectionality .....	2172
Climate Change Vulnerability and Effects Across the Different Agro-ecological Zones ....	2173
The Sudano-Sahelian Zone .....	2173
The Guinean Savannah Zone .....	2175
The Western Highlands Zone .....	2175
Coastal Lowlands or Mono-modal Forest Zone .....	2175
The Bimodal Forest Zone .....	2176
Farmers Household and Community Adaptation Strategies .....	2176
Women and Land Tenure in Cameroon .....	2177
Muslim Communities .....	2178
Anglophone Communities .....	2179
Francophone Communities .....	2180
Intersectionality and Climate Change Adaptation .....	2181
Women and Climate Change Adaptation Within the Muslim Community .....	2181
Women and Climate Change Adaptation Within the Anglophone Community .....	2183
Women and Climate Change Adaptation Within the Francophone Community .....	2185
Caveats/Limitations of the Study .....	2186
Conclusion .....	2186
Recommendations .....	2187
References .....	2189

This chapter was previously published non-open access with exclusive rights reserved by the Publisher. It has been changed retrospectively to open access under a CC BY 4.0 license and the copyright holder is “The Author(s)”. For further details, please see the license information at the end of the chapter.

F. Ngum (✉)  
Lilongwe, Malawi

J. Bastiaensen  
Institute of Development Policy (IOB), University of Antwerp, Antwerp, Belgium  
e-mail: [johan.bastiaensen@uantwerpen.be](mailto:johan.bastiaensen@uantwerpen.be)

---

**Abstract**

It is a widely accepted notion that climate change affects men and women within agrarian populations differently; consequently, their adaptation strategies are gendered. Besides climate change, women's vulnerability and their corresponding adaptation strategies are embedded within a complex web of social identities/status, agroecological location, gender norm/roles and power struggles within the plurality of normative orders governing land (property rights). This chapter focuses on Cameroon and seeks to analyze how the interactions between various normative orders governing access to land, co-dependent upon the multiple gendered identities (intersectionality), impact climate change adaptation strategies of female farmers. The results show that the degree of vulnerability and adaptation strategies of women are context specific and gendered across the five distinct agroecological zones of Cameroon. Furthermore, secured access to and ownership over land is crucial in determining the adaptation choices and options available to female farmers. A complex mix of state and non-state norms govern property rights in Cameroon, within which women have to constantly negotiate their land claims. These negotiations are influenced by marital status, ethnicity, educational level, and community/social relations, such that the outcome translates differently for women within the Muslim, Anglophone, and Francophone communities. The chapter concludes with context-specific recommendations to strengthen the adaptive capacity of agrarian women across Cameroon.

---

**Keywords**

Women · Property rights · Intersectionality · Climate change · Adaptation · Cameroon

---

**Introduction**

Climate change and its adverse effects on the livelihoods of agrarian communities in the global south have gained visibility within global development debates. Although these adverse effects are diverse and context specific, they are projected to hit developing countries in the global south the hardest due to technological, resource, and institutional constraints to adaptation, as well as their over dependence on natural resources as a livelihood base (Ngondjeb 2013; Pumenta 2014). Furthermore, issues of gender and climate change adaptation are increasingly being raised as women are looked upon as a marginalized vulnerable group relying on agriculture and natural resource related activities for sustenance (Denton 2002; Arora-Jonsson 2011; Kaijser and Kronsell 2013). Gender roles/norms, unequal power relations, differential access and entitlements to land entails differences in the level of vulnerability, and effects of climate change on agrarian men and women, as well as their adaptive capacity. Thus, it is a widely accepted notion that climate change affects men and women within agrarian populations differently;



consequently, their adaptation strategies are gendered (Denton 2002; Arora-Jonsson 2011). However, most studies focus on the binary construction of gender (men vs. women) thereby overlooking the influence of other factors such as geographical location, social relations, power, social/societal norms, social identities, etc. on the adaptive strategies of farmers, especially women (Kaijser and Kronsell 2013; Osborne 2013; Carr and Thompson 2014; Kings 2017). Recent intersectionality approaches to gender analysis have, however, demonstrated that the gender binary needs to be interconnected with other markers of identity and social position (Kaijser and Kronsell 2013; Osborne 2013; Van Aelst and Holvoet 2016; Boltana 2017; Elum et al. 2017).

In an agrarian economy like Cameroon with five distinct agro-ecological zones where subsistence agriculture is the mainstay for about 80% of the country's population (Molua 2011; Pumenta 2014), the effects of climate change are multiple and diverse, with negative consequences dominating. With most smallholder farmers highly dependent on rain-fed agriculture, climate variability and changes are detrimental to their livelihood base and as such the agricultural sector is among the most vulnerable to the risks and impacts of climate change (Tingem and Rivington 2009; Pumenta 2014). Although agriculture is the livelihood base for most Cameroonians, women are the backbone of smallholder agriculture and food crop production, bearing most of the responsibility of household sustenance. Women constitute 51% of the entire Cameroonian population, 51.3% of whom rely exclusively on livelihood activities that are directly linked to the natural environment (Molua 2011; UICN-PC 2015; Beckline et al. 2017). Women are thus highly vulnerable to the impacts of climate change. Besides climate change, the agrarian livelihood base of these women is further complicated by a dual land tenure system within which women (based on their social identity/status and related gender norms) are constantly negotiating land access and rights, trying to mobilize the appropriate gender and customary norms that can be used to enforce their land claims (Faith 2019). Thus, women's vulnerability to climate change and their corresponding adaptation strategies are embedded within a complex web of social identities, gender roles, and power struggles over land within the various agroecological zones. Hence, the need to look at an intersectional perspective of factors that influence climate change adaptation strategies of agrarian women in Cameroon.

This chapter therefore seeks to analyze how the interactions between various normative orders governing access to land, co-dependent upon the multiple gendered identities (intersectionality), impact climate change adaptation strategies of female farmers in Cameroon. It reviews how climate change affects agrarian populations and how they generally adapt, both at the household and community level. Specific attention will then be given to women's access to farmland within the plurality of normative orders governing land and how land rights, social identities, and socioeconomic factors jointly influence their adaptation strategies (intersectionality).

This chapter is an exploratory desk study based on general literature review and discourse analysis of peer-reviewed journal articles, government policy documents, reports, and other unpublished texts about gender/women, climate change

vulnerability and adaption strategies, intersectionality, and land governance. A keyword search was used to identify and isolate relevant texts, using gender/women, climate change adaptation, climate change vulnerability, intersectionality, smallholder farmers, and land tenure as keywords. Approximately 50 documents were obtained from the keyword search. In order to understand the current/recent dynamics relating women and intersectionality to land tenure, climate change vulnerability and adaptation in Cameroon, the focus was on literature (journal articles, policy documents, reports, etc.) produced within the last 10 years (2009–2019), except one document on land tenure issues in Cameroon which dates back to 1996. This document was retained because no other recent/current document was found. Thus, based on their relevance to the study, a quick scan through the 50 documents obtained led to the elimination of 15 documents. In summary, this chapter exploits literature from 35 documents on the following thematic areas:

- Gender, climate change vulnerability and adaptation strategies
- Land rights, smallholder agriculture, intersectionality, and climate change adaptation

---

## Conceptual Framework: Intersectionality

This study adopts the concept of intersectionality that emerged as a critique of the universalism of women's oppression portrayed by initial Western feminist movements. The concept of intersectionality was first used by black feminist (specifically by Kimberlé Crenshaw) to elucidate the triple oppression and discrimination of women of color resulting from an interplay of race, gender, and class. Although the concept emanates from black feminist movements, it has evolved over the years into multiple disciplines of feminist research to illuminate the interconnectedness of power and multiple axes of irreducible social categories (beyond race, gender, and class), and their effect on the identity and lived experiences of women (Davis 2008; Cho et al. 2013; Kaijser and Kronsell 2013; Kings 2017). However, even within feminist research, intersectionality has been defined, interpreted, and used in various ways (an analytical tool, a research paradigm, a buzzword, etc.). Given the ambiguity and open-endedness of the concept, we define intersectionality as "*the interaction between gender, race and other categories of difference in individual lives, social practices, institutional arrangements, and cultural ideologies and the outcomes of these interactions in terms of power*" (Davis 2008, p. 68). This definition highlights the fact that intersectionality is inextricably linked to power analysis between an infinite combination of overlapping social identities and categories that culminates to inequalities, discrimination, and oppression within a broader societal context. Put simply, intersectionality acknowledges that oppression is the outcome of interactions of multiple simultaneously linked identities, power relations, and lived experiences. Thus, the concept of intersectionality has been applied in myriad ways within critical feminist studies to highlight the historical "situatedness," social relations, and power structures that results into the irreducible, layered and co-constitutive identities of women within in a given context (Cho et al. 2013; Osborne 2013; Hankivsky 2014).

Within the context of climate change, “[t]he responsibility, vulnerability, and decision-making power of individuals and groups in relation to climate change can be attributed to social structures based on characteristics such as gender, socio-economic status, ethnicity, nationality, [...] and place” (Kaijser and Kronsell 2013, p. 420). Consequently, the impacts and corresponding adaptations strategies of individuals and groups may reinforce or alternatively change these social structures and categories. Thus, the degree of climate change vulnerability, impacts, and adaptation strategies of smallholder farmers (especially women) is influenced by multiple intersecting social identities embedded in power structures (Arora-Jonsson 2011; Kaijser and Kronsell 2013; Osborne 2013; Carr and Thompson 2014; Hankivsky 2014; Kings 2017). Hence adopting the lens of intersectionality moves beyond “women as a homogenous analytical category” to unravel the dynamics of the interconnectedness of power, social relations, socioeconomic status and their various co-constitutive and mutually enforcing identities of women in relation to climate change vulnerability, impacts, and adaptations. This permits an informed and constructive understanding of gender and the multiple normative orders that determine the lived experiences and “true” effects of climate change on women within agrarian communities in Cameroon. An intersectional approach will therefore incorporate the concepts of gender, land tenure, and socio-economic status so as to gain critical and constructive insights on the vulnerability, impacts, and adaptation strategies of over 50% of women in Cameroon reliant on agriculture and other natural resource base activities for sustenance in different agroecological zones.

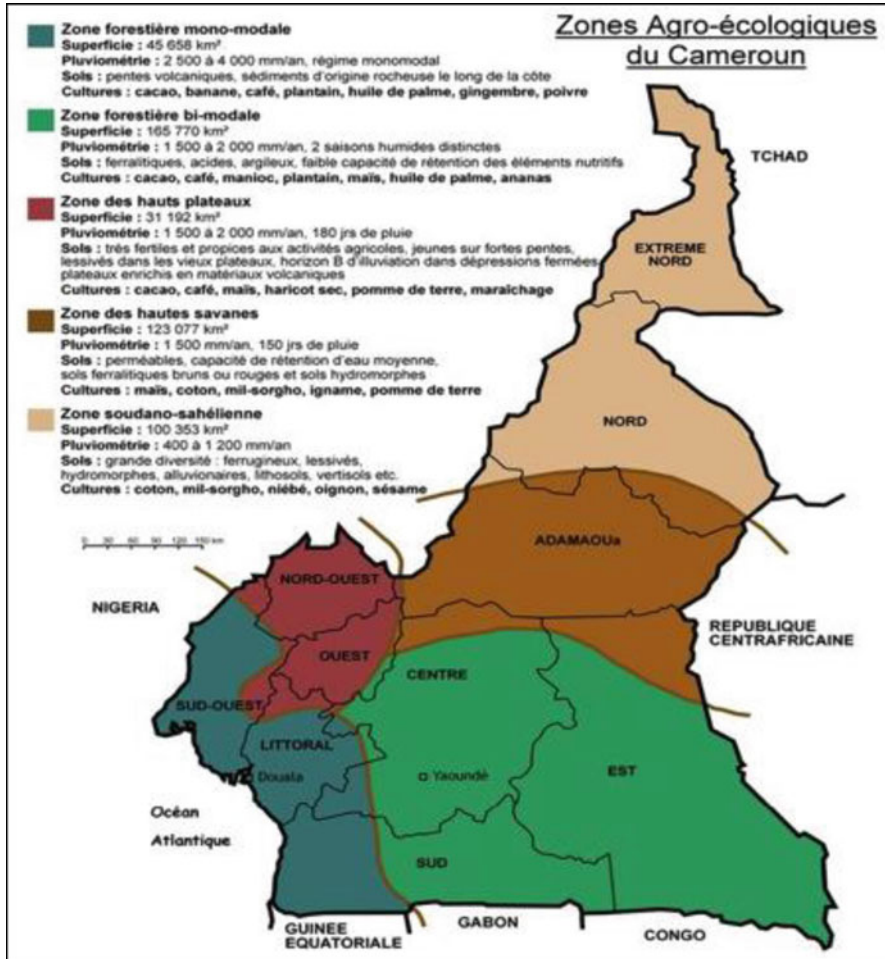
---

## **Climate Change Vulnerability and Effects Across the Different Agro-ecological Zones**

In an agrarian economy like Cameroon, where a majority of the population rely on rain-fed agriculture and natural resource exploitation (especially forestry and non-timber forest products–NTFPs) for sustenance, climate change impinges on the climate-sensitive livelihood activities of most Cameroonians. Cameroon currently faces increased annual average temperatures and seasonal rainfall fluctuations with accompanying hazards such droughts, floods, heat waves, mudslides, etc. which are experienced differently across the country’s agro-ecological zones, with diverse effects and impacts on the farmers. Located between West and Central Africa, Cameroon has five distinct agro-ecological zones with distinct topographic and climatic diversity which can be assumed to account for the variations in the degree of vulnerability and corresponding effects on agricultural activities within each zone (Yengoh et al. 2010; Pumenta 2014; MINEPDED 2015). Figure 1 presents five agroecological zones and their distribution across the national territory.

### **The Sudano-Sahelian Zone**

Covering the North and Far North Regions, it is the driest part of the country with a semiarid climate. Annual temperatures here range between 17 °C and 34 °C over



**Fig. 1** Agro-ecological zones of Cameroon. (Source: MINEPDED 2015, p. 24)

long periods of the year making it highly vulnerable to droughts, heat waves, and dry spells. Despite its low rainfall distribution (between 400 mm and 1200 mm), extreme interannual variability often with strong torrential showers are common, making the regions periodically vulnerable to floods (with high incidence of waterborne diseases). It is the most vulnerable zone in Cameroon with serious repercussions on the agricultural sector. Some of the consequences of climatic variations include: drop in crop yields (resulting from poor germination, crop drying), decreased fodder coverage, increased proliferation of animal pest (especially tsetse fly) and livestock mortality, drying up of water bodies (lakes and ponds), drop in fish production, and exhaustion of fish stocks. The abovementioned consequences translate to famine and food insecurity, increased conflicts over arable land, and population migration to other regions (Yengoh et al. 2010; Pumenta 2014; MINEPDED 2015).

## **The Guinean Savannah Zone**

It covers the Adamawa region and is a transition zone between the moist equatorial southern regions and the drier Sahelian northern regions. It is characterized by average temperatures of 22 °C and annual rainfall ranging between 700 mm and 1500 mm making it suitable for production of a variety of crops and livestock. This zone is considered the “breadbasket” of the country but with increasing temperatures, decreasing precipitation together with erratic rainfall patterns, the region is vulnerable to droughts, dry spells, and heat waves. The effects and impacts of climate variations in this zone are similar to those of the Sudano-Sahelian zone presented in the previous section, although more moderate (Yengoh et al. 2010; Pumenta 2014; MINEPDED 2015).

## **The Western Highlands Zone**

It covers the West and North-West Regions of the country. Although it has a savannah vegetation, its mountainous topography with high plateaus (over 800 m tall) influences its climate. Influenced by this orographic effect, its annual rainfall ranges between 1500 mm and 2000 mm with an average temperature of 20 °C giving it a cold equatorial climate with the possibility of off-season rains. This region experiences the highest seasonal fluctuations of rainfall and temperature patterns. Climate variations here results in drop in crop yields (crop decay during flooding, soil leaching, and erosion), increase proliferation of animal pest (especially tsetse fly), and livestock mortality. These translate to increased competition over arable land and farmer-grazer conflicts. However, erratic rainfall patterns provide the opportunity of off-season farming and thus stabilizing crop production in this zone (Molua 2009; Yengoh et al. 2010; MINEPDED 2015; Innocent et al. 2016).

## **Coastal Lowlands or Mono-modal Forest Zone**

It covers the Littoral and South-West mountainous regions characterized by a rainy, hot, and humid equatorial climate. It registers the highest rainfall in the country ranging between 2500 mm and 4000 mm throughout the year with mean temperatures of 28 °C. The population practice artisanal fishing and fish farming, and its rich volcanic soils, moisture-laden tropical maritime climate, and sea access makes it suitable for roots, tubers, and plantation agriculture. However, with increasing temperatures and intense rainfall, this zone is vulnerable to sea level rise, storm surges, floods, and mass movements such as landslides, mudslides, and falling rocks with negative effects on the population. Variations in climatic parameters results in increased proliferation of pest (malaria parasites), saline water intrusion and destruction of salt-intolerant crops, destruction of mangrove habitats, and increased waterborne diseases. However, increased sea temperatures also lead to improved fish habitat and changes in fish species diversity, hence a beneficial effect of climate

change (Yengoh et al. 2010; Bele et al. 2013; MINEPDED 2015; Beckline et al. 2017).

## The Bimodal Forest Zone

Covering the Center, South, and East Regions of the country, this zone harbors the country's dense evergreen tropical forest vegetation, with an average temperature of 23 °C and annual rainfall between 1,500 and 3,000 m. Exploitation of forest resources (including NTFPs and hunting), agriculture (mostly cocoa production and poultry farming), and artisanal fishing remain the principal activities of most households. Increased temperatures and decreased rainfall results in nonavailability of NTFP, increase in animal species mortality, and decrease in crop yields. However, occasional drying up of swamps and marshlands provides an opportunity for vegetable cultivation, which is a beneficial effect of climate change (Sonwa et al. 2012; Bele et al. 2013; MINEPDED 2015).

---

## Farmers Household and Community Adaptation Strategies

Cameroon has a National Adaptation Plan of Action (NAPA), which mentions gender issues in reference to the need to incorporate and prioritize women (as a homogenous group) in all sectoral adaptation initiatives at all levels in the different agro-ecological zones. Although the NAPA has clearly defined adaptation initiatives developed by state institutions at national level, its effective implementation at regional and local levels is often limited by structural (poor-coordination within and across ministries), financial, and technological (outdated research and climatological stations) constraints. Thus, farmers and rural households do not rely solely on state assistance for adaptation options. Over the years, they have developed various individual and collective strategies (both on-farm and off-farm) to cope with, and lessen the adverse effects of climate change based on their local knowledge, perception, experience, and interpretation of natural phenomena. Although there is a variability among the adaptation practices of male and female farmers, in general, smallholder farmers (both male and female) adopt a combination of on-farm agricultural practices among the following (Molua 2009, 2011; Tingem and Rivington 2009; Innocent et al. 2016; Beckline et al. 2017):

- Use of improved seed varieties (drought-tolerant and early maturing varieties)
- Seasonal alterations of farm size and/or location
- Adjusting sowing/planting time (early planting in mono-modal and bimodal forest zones, late planting in Sudano-Sahelian and Guinean-Savannah zones) and sequencing (plant spacing, row orientation, terracing)
- Mixed farming, crop rotation, and agroforestry
- Manual irrigation of crops using boreholes, watering cans, and hand buckets
- Installation of sprinkler irrigation systems

- Adjusting level and timing of fertilizer and pesticide application
- Gardening on dried marshlands and swampy areas (in the bimodal forest zones)
- Implementing soil–water conservation techniques (minimum tillage, mulching, use of compost/manure)
- Decreasing herd size, increasing livestock diversity, and switching to heat- and drought-tolerant animal species
- Seasonal animal migration to river banks (transhumance)
- Increase collection and marketing of NTFPs for food and income, respectively

In addition to these agricultural practices, farmers are increasingly engaged in various off-farm income-generating activities to cushion farm income shocks such as petty trading and migration (to seek employment). Distress sale of household assets and reduction in nonfood expenditures are also observed as more detrimental coping mechanisms. Although these individual adaptive measures are successful, there is a limit to its overall contribution in a broader community resilience. Collective action is therefore needed to build community resilience against climatic shocks. Hence, the aforementioned individual adaptation strategies are complemented by other community actions which include: community rotational saving schemes (“*tontines*” or “*njangis*”) with lending possibility, group collection and marketing of NTFP, cultivation of fodder crops for livestock, creation of community fodder banks, creation of community firebreaks (protecting against wild fires), family/community information sharing meetings, and community regulation of common-pool resources (land, water, and forest) (Molua 2011; Bele et al. 2013; Innocent et al. 2016).

The array of on-farm and off-farm adaptation strategies used by farmers in Cameroon vary across the agro-ecological zones and is influenced by an intersection of other factors such as gender, property rights, educational level, income (including credit access), access to technical assistance and extension services (including climate-related research and information) (Molua 2009; Innocent et al. 2016). This highlights the importance of intersectionality in climate change vulnerability and adaptation as will be discussed later.

---

## Women and Land Tenure in Cameroon

Land governance/tenure in Cameroon is characterized by a plurality of normative orders, wherein the effective “rules-in-use” and daily management practices are determined by the interaction between colonial and post-independence state “law” (state normative order) on one hand, and the existing social/cultural norms of the people on the other hand (Belaunde et al. 2010; Pumenta 2014). A series of gender-neutral laws, decrees, ordinances, and their corresponding implementing institutions define the state normative order. Shaped by its colonial history, the state normative order, which is applicable to the entire national territory, is based on the notion of “private ownership” and land registration documented by formal instruments (title deeds) as a basis for securing property rights and economic development. Resource access and subsequent rights are therefore determined by the

ability to pay (Van den Berg 1996; Fonjong 2012; Fonjong et al. 2013; Pumenta 2014; Njoh et al. 2017). This provides equal opportunity for all irrespective of gender, ethnicity, or religious background to have unchallenged rights over land. However, various financial and socio-cultural factors shape the gender-differentiated access to land.

The religious and social/cultural norms (non-state normative order) governing land are based on communal ownership, with slight differences across the country especially concerning women's land claims, as these engulf gender norms and roles embedded within unequal and changing power relations (Faith 2019). Cameroon is made of over 250 different ethnic groups spread across the ten regions of the country with diverse gender ideologies, norms and roles in relation to land, natural resource management, and agricultural production (Njoh et al. 2017; Faith 2019). Thus, as Van den Berg (1996) opines, "*ideas about breadwinnership, the division of labour and responsibilities within the household largely influence women's access to land*" (p. 18). However, these 250 ethnic groups can be regrouped under three main communities based on their religious (Christian or Muslim), linguistic (Arabic, French, or English), and colonial history, namely (Van den Berg 1996; Ahidjo 2012; Njoh et al. 2017; Faith 2019):

- Muslim community: made of the French- and Arabic-speaking Adamawa, North and Far North Regions of Cameroon, colonized by the Arabs, Germans, and French.
- Anglophone community: predominantly Christians and comprised of the English-speaking North-West and South-West Regions of Cameroon, colonized by the Germans and British.
- Francophone communities: predominantly Christians and comprised of the French-speaking South, East, West, Littoral, and Center Regions of Cameroon, colonized by the Germans and French.

Within these communities, a woman's access to and rights over land is determined by a mix of colonial, state, and non-state normative orders, influenced by other social determinants such as gender norms, ethnicity, and socio-economic status. The following sections highlights daily struggles female farmers encounter to access arable land across the different communities.

## **Muslim Communities**

Within the Muslim communities, an important determinant of a female farmers' intra-household access to land is her marital status, as wives primarily rely on their husbands to gain access to farmland. However, access to farmland is not automatic upon marriage but earned through years of marital compliance, successful reproduction, and labor provision on the family field/farm. Wives are granted permissive use rights on degraded marginal or fallow lands for food crop cultivation, while their husbands still hold control and transfer rights over the land. With divorce or



widowhood, divorcees lose access and rights over family land while widows with minor children may be granted usufruct and “limited” control rights over land held in trust of their son (the heir to the land). Nevertheless, wives, divorcees, and widows have devised alternative means to temporarily obtain farmland in their community within the appropriate socio-cultural norms used to enforce their land claims, such as renting and sharecropping. Inheritance and purchasing land could be a viable option of obtaining secured property rights but land ownership by “women” is stereotyped as a threat to family unity (decrease of sibling/son’s inheritance or signs of marital discord), thus land purchase by women is almost inexistent within the Muslim communities. Furthermore, daughters and widows can only inherit land in the complete absence of a male relation (which is never the case) (Van den Berg 1996; Ahidjo 2012; Faith 2019). The insecure and temporary nature of these land tenure arrangements often limits the amount of investment Muslim women can and are willing to make on the farmland. With the advent of climate change, their adaptation strategies are therefore constrained.

## Anglophone Communities

Within the household, Anglophone women also acquire land through male relations (fathers, husbands, and sons). However, differences exist in the rights and degree of control Anglophone women hold over land. Daughters are granted “permanent” use rights on family land and could inherit the land provided she remains unmarried even though sons are prioritized in relation to land inheritance. Upon marriage, wives are automatically granted usufruct rights on family land by her husband or his kinsmen, to ensure their principal duty of household food production (unlike Muslim wives who earn their access to farmland). At the discretion of the kinsmen, widows may keep their farmland as trustees for their sons (patrilineal inheritance) or nephews (matrilineal inheritance) with a greater degree for control and management rights. Divorced women are dispossessed of any rights they held over the husband’s family land and return to their natal family for land or seek alternative strategies of acquiring farmland. However, although men in this community “own” the land, women hold the decision-making power and controls what is cultivated on the land, how her labor is allocated, and how the farm proceeds are used (Van den Berg 1996; Pumenta 2017; Faith 2019).

Besides relying almost exclusively on male relations for farmland, in the community sphere, Anglophone women (daughters, wives, mothers, widows, or divorcees) have also been known to “clear and claim” land as their own, as well as acquire land through renting, collective access of communal land, purchase, and registration. Irrespective of any socio-cultural and administrative bottlenecks (gender-biased norms, high cost, bureaucracy, etc.) associated with women’s land purchase, Anglophone women have been able to circumvent these obstacles by using male relatives to buy land or “courting” both traditional and state authorities to buy land in their name (Van den Berg 1996; Pumenta 2017; Faith 2019). Although possible variability in terms of income levels, class, educational level, and social

relations influence their land claims and rights enforcement, women (state bureaucrats, elites, and “business” women) own about 3% of the registered land in the Anglophone communities (Pemunta 2017). Furthermore, regrouping themselves into farmers organizations to access communal land and also pool resources to purchase land for collective food production and market gardening is an important strategy for which Anglophone women have proven to exert more power in bargaining and enforcing their land claims within both state and non-state normative orders (Fonjong et al. 2013; Pumenta 2017; Faith 2019). Although, variations exist in terms of access to land and security of tenure, most Anglophone women have more or less “secured” property rights and can therefore make pertinent management decisions to undertake long-term sustainable investments on their farmlands and reap the benefits. They are therefore more likely to adopt sustainable climate smart practices to cope with the adverse effects of climate change.

### **Francophone Communities**

A Francophone woman’s primary duty within the household (in accordance with socio-cultural norms) is to provide labor support on the family farm. Hence, access to land is conditioned on her “relationship” with the men in the family. Daughters assist in farming activities as well as the collection and processing of NTFPs. Upon marriage, wives acquire a share in the land of her mother-in-law or husband, on which they can cultivate food crops and vegetables (Fonjong 2012; UICN-PC 2015). Although men hold superior power over women (daughters and wives), household decisions over crop production and labor allocation are jointly made by husband and wife. Furthermore, the sociocultural norms generally protect the land claims of all farmers irrespective of gender, social identity, or ethnic origin (women can and do inherit land), although in some rare instances, widowhood and divorce may lead to loss of farmland by women (Gyau et al. 2014; UICN-PC 2015). Besides relying on family relations for land, women (wives and widows) also engage in temporary arrangements such as renting and sharecropping as alternative means of accessing additional farmland with limited management rights over these lands. Nevertheless, some financially viable women occasionally purchase land for construction or other non-agricultural developmental purposes in urban areas as evidenced in the Center Region where women (mostly state bureaucrats) own about 15% of all registered land (Gyau et al. 2014; Pumenta 2017). Thus, Francophone women generally have secured property rights that provides them with the power and means to equitably negotiate the diversification of their livelihoods and adapt to climatic changes.

In summary, despite the diverse socio-cultural norms across the country, the land rights of most Cameroonian women are co-dependent on male relations. However, the effective rule-in-use over land management as well as the intra-household decision-making power varies across these communities. Nevertheless, women contribute substantially in agricultural production and other livelihood activities, and are primarily responsible for household subsistence despite the gender-differentiated access and rights to resources.

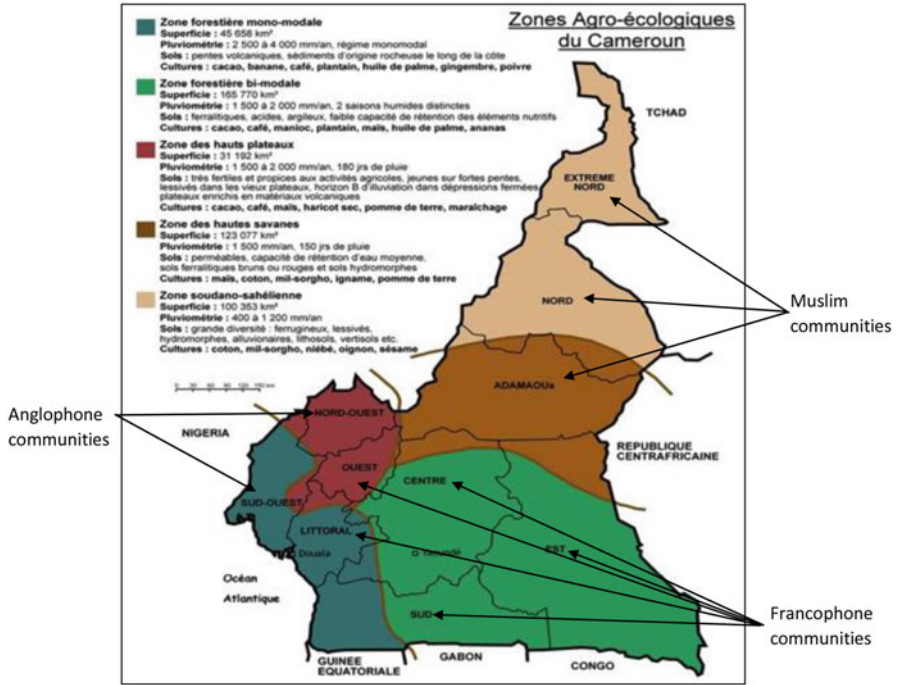
## Intersectionality and Climate Change Adaptation

Beyond the binary division of men versus women, a combination of other societal norms and socio-economic factors influence women's adaptive capacity. Consequently, an intersectional analysis is required to understand the underlying norms, power relations, and socio-economic factors that conditions the daily/seasonal adaptation practices, and strategies employed by women (Kaijser and Kronsell 2013; Carr and Thompson 2014). In Cameroon, with over 50% of the female population relying on agriculture and natural resources for sustenance (Molua 2011; Pumenta 2017), women constitute an important group for whom risk aversion is vital for household welfare. However, the degree of vulnerability and effects of climate change on the livelihood activities of women depends on their location (agro-ecological zone), the diverse socio-cultural norms that prescribe access to and control over land, and decision-making power (as presented in the previous sections). Consequently, the adaptation strategies of women will vary across the country based on an intersection of gender, ethnicity, and agro-ecological location, as well as other factors such as educational level, access to information, access to extension services (technical assistance), income (including access to credit), social capital, etc. Hence, based on the findings of the previous sections, this section analyses the effects of an intersection of gender, ethnicity (in terms of land governance and decision-making power), and agro-ecological location (and other factors) on women's adaptation options within the northern Muslim community, southern Francophone and Anglophone communities. Figure 2 highlights the spatial distribution of these communities across the different agro-ecological zones.

### Women and Climate Change Adaptation Within the Muslim Community

The Muslim community of Cameroon is predominantly located in the northern semi-arid agro-ecological zones, comprised of the Sudano-Sahelian and Guinean Savannah agro-ecological zones. Climatic variations and extreme weather events such as droughts, heat waves, dry spells, and occasional floods lead to decreased crop yields/productivity and increased population migration to other regions (mostly men) (Yengoh et al. 2010; Pumenta 2014; MINEPDED 2015). In line with their domestic/reproductive roles, Muslim women are generally involved in food crop production (on marginal lands acquired through male relations), processing and marketing of livestock and fishery products but lack control over how the proceeds are used (Van den Berg 1996; Ahidjo 2012; Njoh et al. 2017).

The temporary migration of Muslim men during periods of transhumance and in search of off-farm employment in other regions implies an increase in the number of de facto female-headed households with increases in the reproductive and productive activities of wives who are left to care for ("sick") family members while ensuring sufficient food production for the household. Although some women are engaged in petty trading, the increased workload of domestic activities limits their possibility of



**Fig. 2** Spatial distribution of the various communities across the different agro-ecological zones. (Source: Adapted from MINEPDED 2015)

diversifying their livelihood strategies and undertaking off-farm activities that could contribute to the household income. This is further exacerbated by the high illiteracy level among Muslim women, due to the gender ideology that prioritizes early marriage over girls’ continuous education, thereby limiting their options of off-farm employment (Van den Berg 1996; Pumenta 2014). Furthermore, men generally hold decision-making power over the wife’s labor and income allocation. Thus, for most Muslim women (wives, widows, mothers, and divorcees), their livelihood activities and adaptation strategies are centered around on-farm activities.

The on-farm adaptation strategies of Muslim women are constrained by religious and sociocultural norms that “forbid” ownership of land by women. Since women (daughters, wives, widows, and divorcees) only have usufruct rights on family or rented/sharecropping land, and “limited” decision-making power, their on-farm adaptations strategies are therefore limited to seasonal crop management practices and farming operations such as alterations in planting dates, use of drought tolerant or early maturing hybrid seeds, and mixed cropping. Furthermore, because of the limited property rights and temporal tenure arrangements (renting or sharecropping), Muslim women are unlikely to cultivate cash crops (except millet) that could increase their income (Van den Berg 1996; Molua 2011, 2012). The exception seems to be the case of widows with minor sons who have “limited” control rights

over land held in trust for their sons. These widows can therefore undertake long-term investments such as tree planting (agroforestry) and soil management to safeguard the land while ensuring continuous household food production. As Van den Berg (1996) highlights, tree planting was used by widows as a means of securing and enforcing their land claims.

Beyond security of tenure and decision-making power, the choice of on-farm adaptation strategies implemented varies among women and is influenced by other factors such as income (to purchase drought tolerant or early maturing hybrid seeds), access to climate information and technical assistance. While farmers may generally have knowledge of the weather forecast and expected start of farming seasons (Molua 2011, 2012), Muslim women generally have limited access to agricultural extension services, as these services often target cash crop producers who are predominantly men. This limits the effective implementation of State's adaptation initiatives as stipulated in the country's NAPA, by sidelining the female population of farmers. Furthermore, while promoting tree planting in semi-arid zones is an essential adaptation initiative of the State (MINEPDED 2015), the limited property rights of Muslim women is a disincentive to engage in tree planting as they may not reap the benefits agroforestry provides in the long run. Thus, a gap exists between the national institutional framework and realities on the ground. Together, the aforementioned factors coupled with the limited livelihood diversification strategy of women and socio-cultural constraints on their adaptive capacity tend to increase the household and community vulnerability, thereby accentuating poverty in the regions.

## **Women and Climate Change Adaptation Within the Anglophone Community**

The Anglophone community is comprised of the North-West and South-West Regions of Cameroon spread in two different agro-ecological zones. The North-West Region (NWR) is located within the western highlands zone, while the South-West Region (SWR) is located within the mono-modal forest zone. Climatic variations in the NWR leads to soil degradation (through leaching and erosion) and consequently drop in crop yields. In the SWR, extreme weather events, such as floods, lead to increased proliferation of malaria parasites, high incidence of waterborne diseases, saline water intrusion and destruction of salt-intolerant crops (MINEPDED 2015; Innocent et al. 2016; Beckline et al. 2017). In line with their reproductive roles, ensuring household food security is the responsibility of Anglophone women. Thus, farming (food crop and vegetable production) is the main livelihood activity of most women in these communities (Van den Berg 1996; Fonjong et al. 2013).

Health issues resulting from malaria parasites or waterborne diseases implies an increased workload on the domestic/reproductive roles of women (wives, mothers, widows, and divorcees) to nurture and care for the sick family members. This also increases their workloads in agriculture since they are tasked with ensuring

household food security. However, Anglophone women as wives, widows, and divorcees decide and control how their labor or any proceeds from their farms is allocated (Van den Berg 1996; Pumenta 2017). They therefore have the possibility of diversifying their livelihood strategies and engaging in other flexible off-farm activities to generate income that could caution the adverse effects of climate change on their agrarian livelihood base. This is further facilitated by their relatively high literacy level (compared to the Muslim women) that enables them gain off-farm employment. From the researcher's lived experience, the high literacy level within Anglophone women may be considered the result of a trade-off wherein the education of female children serves as compensation for their limited inheritance rights.

Although an interaction of sociocultural norms and state "laws" dictate women's access to land and other natural resources, some Anglophone women have been able to manoeuvre and "forum shop" from both systems to acquire more or less "secured" property rights over their farmland. While "high" income women such as state bureaucrats, elites, and "business" women have been able to purchase, title, and effectively own land, rural women with limited financial capital rely on their social networks/capital to regroup themselves and gain "secured" access to community land. Furthermore, by virtue of being the "breadbaskets" of the family, women generally have secured access to "family" land whether as a daughter, wife, mother, or widow (Fonjong et al. 2013; Pumenta 2017). Thus, the security of tenure provides an incentive to adopt and invest in sustainable soil management and agricultural practices such as agroforestry, recycling of dead organic matter, mulching, and reap the long-term benefits. Nevertheless, Anglophone women also engage in seasonal farming practices such as making "mounds," mixed cropping, off-season replanting, use of improved seed varieties, changing planting dates, etc. as coping strategies to the fluctuating climates in these zones (Beckline et al. 2017).

Beyond security of tenure and decision-making power, access to climate information and agricultural extension services also influence the on-farm adaptation strategies implemented by Anglophone women. Although both women and men get access to climate information from formal (weather observatory officers) sources through radios, print media, and televisions, as well as informal sources such as friends, family, and self-help groups (Molua 2011; Fonjong et al. 2013), access to agricultural extension services is correlated to group membership, social status, and class. While extension services target farmers groups/cooperatives (irrespective of the gender composition of the groups), "working class" women have the possibility of networking with and obtaining assistance from extension agents. Thus, being a full-time "housewife" and belonging to no farming group impinges on a woman's access to technical assistance. However, most Anglophone women belong to self-help and community saving groups ("njangis") which serves as a buffer against financial crisis in times of disasters and emergencies on one hand, and as a platform of socialization, information sharing, and peer learning within the communities on the other hand (Molua 2011; Fonjong et al. 2013; Innocent et al. 2016). Thus, Anglophone women seem less vulnerable and more proactive in adopting conservation and protective on-farm practices compared to their Muslim counterparts.

## Women and Climate Change Adaptation Within the Francophone Community

The Francophone community is made of five administrative regions spread across three different agro-ecological zones. It is comprised of the West Region (located in the western highlands zone), the East, South, and Center Regions (located in the bimodal forest zone), and the Littoral Region (located in the mono-modal forest zone). Seasonal weather fluctuations in the western highlands and bimodal forest zones lead to soil erosion and drop in crop yields, and increased scarcity of NTFPs. In the mono-modal forest zone, sea level rise and extreme weather events, such as floods, leads to increased proliferation of malaria parasites, high incidence of waterborne diseases, saline water intrusion and destruction of salt-intolerant crops (Yengoh et al. 2010; Sonwa et al. 2012; Bele et al. 2013; MINEPDED 2015).

In addition to their reproductive roles, a Francophone woman's main duty as a daughter or wife is to provide labor support on the family farm. Although cash crop (mainly cocoa) production and fishing by men are the main livelihood activities, Francophone women (wives, mothers, divorcees, and widows) are involved in food crop and vegetable production on farmland acquired through diverse means. With both the state and non-state normative orders protecting the land and natural resource claims of women, the security of tenure provides women with the power to negotiate the diversification of their livelihoods. Being educated and earning an income is a bonus as it influences the intra-household bargaining power of women. Women therefore engage in diverse off-farm employment and income-generating activities such as petty trading of food crops, collection, processing and marketing of NTFPs, as well as processing and marketing of fishery products (Sonwa et al. 2012; Brown and Sonwa 2015; UICN-PC 2015; Beckline et al. 2017; Pumenta 2017). This off-farm income helps cushion against the negative effects of changing climatic conditions on the agrarian livelihood base of the household. Furthermore, Francophone women engage in precautionary loan-savings schemes ("tontines") which provides women with easy and flexible access to credit that is used for on-farm and/or off-farm income-generating activities. This contributes in enhancing household income and general welfare, as well as provide financial insurance in times of disasters and emergencies. Francophone women also engage in community labor-sharing groups that provides mutual labor support on their farm. Since membership to these are based on trust, solidarity, and reciprocity, these groups are indicative of the social capital within this community, which can serve as an entry point for distribution of information, peer learning, and technology adoption (Molua 2011; Bele et al. 2013; Brown and Sonwa 2015), and thereby enhance their general well-being and adaptation potential.

Like the Anglophone and Muslim women, the incidence of malaria and waterborne diseases implies a disproportionate burden on the reproductive activities of women to nurture and care for the sick family members. However, since household farming decisions are jointly made (Gyau et al. 2014), wives have the possibility to trade-off their on-farm labor support with domestic care roles.

In summary, although female farmers across Cameroon seem to opt for relatively low resource (cost and labor) on-farm adaptation methods which can contribute to yield stabilization (Molua 2011), a variability exist among these women influenced by a combination of other socio-cultural norms and socio-economic factors. This aligns with growing literature on gender, intersectionality, and climate change which has shown that socio-cultural norms including gender relations and power dynamics which determines resource allocation and use, division of labor, and decision-making within and beyond the household influence the adaptation strategies of women. Furthermore, an intersection of other socio-economic factors jointly determines the adaptation options and choices available to women. These factors include income/wealth, educational level, place/location, marital status, class, ethnicity, group membership, access to information, technology, extension services, etc. Nevertheless, irrespective of any constraint posed by societal/sociocultural norms and other socioeconomic factors, female farmers continue to exercise their agency and adapt to changing climatic conditions in diverse ways as the circumstances present. Thus, the adaptation strategies of women within agrarian societies in Cameroon are context specific.

---

### **Caveats/Limitations of the Study**

This desk study adopts a critical theorist (feminist) stance, which guides the scope of analysis and recommendations with an undeniable bias of the researcher's position. This chapter is led by a female agronomist, with lived experiences of the daily struggles Cameroonian women encounter over land and natural resources. Although the authors aim to limit the researcher's influence through self-reflective honesty and interaction with the second, more distant author, it cannot entirely erase the influence of this specific positionality, but this should not be considered a problem in this exploratory study. Furthermore, because this study relies exclusively on secondary literature (with minimal sex disaggregated data), its analysis is not exhaustive of the current realities, dynamics, and complexities of climate variability/change on agrarian livelihood systems on the ground, an in-depth field research will be needed to achieve this. Nevertheless, the conclusion and modest recommendations will shed light on the ongoing debate on intersectionality and climate change adaptation, and propose alternatives that can work in Cameroon.

---

### **Conclusion**

In line with the growing debate on gender, intersectionality, and climate change, this study set out to examine the adaptation strategies of women in Cameroon using an intersectional lens. As discussed, the vulnerabilities and effects of climate change differs across the five agro-ecological zones of Cameroon with the Sudano-Sahelian zone being the most vulnerable zone. While the National Adaptation Plan of Action (NAPA) provides an institutional framework for agrarian adaptation strategies,



limited coordination among sectorial ministries impedes the effective implementation of these strategies at regional and local levels. Furthermore, by classifying women as a monolithic group, the NAPA ignores the various institutional arrangements (gender norms, resource ownership, property rights etc.) and socio-economic factors (education, income, marital status, etc.) that determines the vulnerabilities and adaptation strategies of women. Thus, the national adaptation initiatives targeting women are poorly designed and seems destined to fail from its conception. Nevertheless, farmers (women inclusive) have a wide range of on-farm agricultural practices and off-farm adaptation strategies that are used to counteract the adverse effects of climate change while enhancing their livelihoods and well-being.

With land being a crucial production factor within agrarian communities, resource ownership and property rights constitute an important determinant in the adaptation choices and options of farmers especially women. However, the analysis shows that land tenure/governance across the national territory is diverse and embedded within a complex web of gendered identities, norms, roles, ethnicity, and power dynamics, for which women have to negotiate resource access with other actors. The outcome of these negotiations translates differently for women across the Muslim, Anglophone, and Francophone communities of Cameroon, and therefore influences the on-farm adaptation options and choices of female farmers in these communities.

Beyond gender and security of tenure, we have shown in this study that a range of other factors influences the adaptation strategies of female farmers across the different agroecological zones of Cameroon. These factors include decision-making power, income/wealth, level of education, access to information, access to technical assistance, group membership, and social identity/status (daughter, wife, mother, widow, or divorcee). A variability therefore exists in both the on-farm and off-farm adaptation choices and options available and adopted by women within and between communities be it in the northern semi-arid agro-ecological zone or the Southern savannah and forest agro-ecological zones. Hence, the adaptation strategies of female farmers in Cameroon is highly context specific. These findings are not unique to Cameroon, as research elsewhere have shown the intersection of socio-economic factors on climate change adaptation across Africa (see Boltana (2017) for group membership in Southern Ethiopia, Elum et al. (2017) for access to information in South Africa, Van Aelst and Holvoet (2016) for marital status and intra-household decision-making in Tanzania, etc.). Nevertheless, the study contributes to the current global debate on gender, intersectionality, and climate change by providing insights from the Cameroonian context.

---

## Recommendations

Despite the limited sex-disaggregated and quantitative data, this study could serve as an “eye-opener” and a foundation for further research on intersectionality and climate change adaptation in Cameroon. Thus, an in-depth and contextually grounded analytical research is recommended to shed more light on the existing

variabilities among female farmers within and between the different communities and agroecological zones. Nevertheless, based on this study, a few modest policy recommendations can be proposed as a way forward in enhancing the adaptation strategies of female farmers in Cameroon.

First, ensuring secured access to land for women especially within the Muslim communities can create a window of opportunity to strengthen their bargaining power and enhance their adaptation strategies. While the national land tenure reform proposed in the NAPA seems apparent as a solution, there is need to incorporate “Muslim doctrines” and make special legal provisions for Muslim women who seem to be the most disadvantaged in relations to property rights compared to their Anglophone and Francophone counterparts. Bearing in mind that security of tenure goes beyond state recognition to a matter of power struggles and social relations, sensitizing women on their “constitutional rights to property” and putting in place (or revamp existing) accompanying institutions to ensure effective implementation and gender justice will go a long way to improve the agrarian livelihood and adaptation strategies of female farmers. Also, promoting female farmer groups, cross-country exchanges and engaging with ideological debates about gender and land rights is a step in the right direction towards secured property rights for women.

Second, as education and income have shown to enhance the bargaining power and off-farm adaptation options of women within the Anglophone and Francophone communities, improving the literacy levels and socioeconomic capacity of Muslim girls and women is necessary. Beyond improved literacy levels and socio-economic capacity, education can serve as an empowerment strategy geared towards creating pathways of transforming gender norms in the long run. Thus, affirmative action through educational and vocational training scholarships could be a policy measure of the Ministry of Women Empowerment and the Family (MINPROFF) to improve overall livelihood and adaptation strategies within Muslim communities. Nevertheless, girls from rural areas, especially of enclaved areas within the Anglophone and Francophone communities, should be considered too.

Third, access to information and technical assistance has shown to be significant factors determining the on-farm agricultural adaptation practices of women. Thus, governmental effort by the Ministry of Scientific Research and Innovation (MINRESI) and Ministry of Agriculture and Rural Development (MINADER) in revamping existing meteorological services and making information and extension services more readily and widely available is crucial to enhance the adaptation decisions that women make. While priority should be given to the northern semi-arid zones with frequent droughts and floods as well as the coastal lowlands with frequent floods, storm surges, and mass movements, the other agro-ecological zones should not be neglected as the impacts of climate change in one agroecological zone inherently affects the populations in the other zones.

Fourth and last, community groups (farmer’s cooperatives, self-help, “tontines,” and “njangis”) seem to be a viable option for peer learning, information sharing, financial assistance, and mutual support in Anglophone and Francophone communities. These groups could also serve as a transformative tool to mobilize the power of collective action in strengthening the bargaining power of women within the communities, as illustrated by Anglophone women groups in relation to access to land. The

potential of these groups should be explored and supported to collectively build the adaptive capacity of women and community resilience, through initiating and training members on income-generating entrepreneurial activities, and linking these groups to microfinance institutions/banks for financial assistance through credit. Also initiating such groups within the Muslim community (if none currently exist) could be beneficial too in reducing their vulnerability and enhancing that adaptive capacity. Both MINADER and MINPROFF could spearhead such initiatives.

---

## References

- Ahidjo P (2012) Access to land and the system of land ownership in Northern Cameroon. *J Knowl Manag Econ Inf Technol* 2(3):1–11
- Arora-Jonsson S (2011) Virtue and vulnerability: discourses on women, gender and climate change. *Glob Environ Chang* 21(2):744–751. <https://doi.org/10.1016/j.gloenvcha.2011.01.005>
- Beckline M, Yujun S, Ayonghe S, Etta OL, Constantine I, Richard T (2017) Adaptation of women to climate variability in the southern slopes of the Rumpi Hills of Cameroon. *Agric For Fish* 5(6):272–279. <https://doi.org/10.11648/j.aff.20160506.19>
- Belaunde S, Cortes M, Hogstad J, Ku E, Nascimento K, Trzcinski L (2010) Land, legitimacy and governance in Cameroon. Institute for Research and Debate on Governance and Columbia University School of International and Public Affairs. 70p. Retrieved from: [http://www.institut-gouvernance.org/IMG/pdf/sipa\\_cameroon\\_land\\_legitimacy\\_governance-2010.pdf](http://www.institut-gouvernance.org/IMG/pdf/sipa_cameroon_land_legitimacy_governance-2010.pdf)
- Bele MY, Tiani AM, Somorin OA, Sonwa DJ (2013) Exploring vulnerability and adaptation to climate change of communities in the forest zone of Cameroon. *Clim Chang* 119:875–889. <https://doi.org/10.1007/s10584-013-0738-z>
- Boltana TF (2017) The role of women Self Help Group membership towards collective action in women's adaptive capacity building under changing climatic situations in rural Ethiopia; a case study in Kindo Koysha District; Southern Ethiopia. Masters dissertation, Institute of Development Policy, University of Antwerp, Belgium
- Brown HCP, Sonwa DJ (2015) Rural local institutions and climate change adaptation in forest communities in Cameroon. *Ecol Soc* 20(2):6. <https://doi.org/10.5751/ES-07327-200206>
- Carr ER, Thompson MC (2014) Gender and climate change adaptation in agrarian settings. United States Agency for International Development, Washington, DC
- Cho S, Crenshaw KW, McCall L (2013) Toward a field of intersectionality studies: theory, applications, and praxis. *J Women Cult Soc* 38(4):785–810
- Davis K (2008) Intersectionality as buzzword: a sociology of science perspective on what makes a feminist theory useful. *Fem Theory* 9(1):67–85. <https://doi.org/10.1177/1464700108086364>
- Denton F (2002) Climate change vulnerability, impacts, and adaptation: why does gender matter? *Gend Dev* 10:10–20. <https://doi.org/10.1080/13552070215903>
- Elum ZA, Modise DM, Marr A (2017) Farmer's perception of climate change and responsive strategies in three selected provinces of South Africa. *Climate Risk Management* 16:246–257. <https://doi.org/10.1016/j.crm.2016.11.001>
- Faith AN (2019) Whose land is it? Women's struggles over land in Cameroon (End-of-Module-Paper). IOB, University of Antwerp, Antwerp
- Fonjong LN (2012) Equal rights but unequal power over land: rethinking the process of engendering land ownership and management in Cameroon. In: Fonjong LN (ed) *Issues in women's land rights in Cameroon*. Langaa RPCIG, Mankon Bamenda, pp 19–41
- Fonjong L, Fombe L, Sama-Lang I (2013) The paradox of gender discrimination in land ownership and women's contribution to poverty reduction in Anglophone. *GeoJournal*, 78(3), 575–589. <https://doi.org/10.1007/s10708-012-9452-z>
- Gyau A, Faith AN, Fondjem-Tita D, Ajaga N, Catacutan D (2014) Small-holder farmers' access and rights to land: the case of Njombé in the littoral region of Cameroon. *Afrika Focus, Special Agroforestry Issue* 27(3):23–39

- Hankivsky O (2014) Intersectionality 101. Institute for Intersectionality Research and Policy, Simon Fraser University, Vancouver
- Innocent NM, Bitondo D, Azibo BR (2016) Climate variability and change in the Bamenda highlands of North Western Cameroon: perceptions, impacts and coping mechanisms. *Br J Appl Sci Technol* 12(5):1–18. <https://doi.org/10.9734/BJAST/2016/21818>
- Kaijser A, Kronsell A (2013) Climate change through the lens of intersectionality. *Environ Polit* 0(0):1–17. <https://doi.org/10.1080/09644016.2013.835203>
- Kings AE (2017) Intersectionality and the changing face of ecofeminism. *Ethics Environ* 22(1):63–87. <https://doi.org/10.2979/ethicsenviro.22.1.04>
- MINEPDED – Ministère de l'Environnement, de la Protection de la Nature et du Développement Durable (2015) Plan National d'Adaptation aux Changements Climatiques du Cameroun. Yaoundé, Cameroon: 138 pages + Annexes
- Molua EL (2009) Accommodation of climate change in coastal areas of Cameroon: selection of household-level protection options. *Mitig Adapt Strateg Glob Chang* 14:721–735. <https://doi.org/10.1007/s11027-009-9194-5>
- Molua EL (2011) Farm income, gender differentials and climate risk in Cameroon: typology of male and female adaptation options across agroecologies. *Sustain Sci* 6:21–35. <https://doi.org/10.1007/s11625-010-0123-z>
- Molua EL (2012) Gendered response and risk-coping capacity to climate variability for sustained food security in Northern Cameroon. *Int J Clim Change Strat Manag* 4(3):277–307. <https://doi.org/10.1108/17568691211248739>
- Ngondjeb YD (2013) Agriculture and climate change in Cameroon: an assessment of impacts and adaptation options. *Afr J Sci Technol Innov Dev* 5(1):85–94. <https://doi.org/10.1080/20421338.2013.782151>
- Njoh AJ, Ananga EO, Anchang JY, Ayuk-Etang EMN, Akiwumi FA (2017) Africa's triple heritage, land commodification and women's access to land: lessons from Cameroon, Kenya and Sierra Leone. *J Asian Afr Stud* 52(6):760–779. <https://doi.org/10.1177/0021909615612121>
- Osborne N (2013) Intersectionality and kyriarchy: a framework for approaching power and social justice in planning and climate change adaptation. *Plan Theory* XX(X):1–22. <https://doi.org/10.1177/1473095213516443>
- Pumenta NV (2014) The impact of climate change on food security and health in Northern Cameroon. In: Keyes CB, Lucero OC (eds) *New developments in global warming research; climate change and its causes, effects and prediction*. Nova Science Publishers, New York, pp 1–55
- Pumenta NV (2017) When 'property cannot own property': women's lack of property rights in Cameroon. *Afr J Econ Sust Dev* 6(1):67–85
- Sonwa DJ, Somorin OA, Jum C, Bele MY, Nkem JN (2012) Vulnerability, forest-related sectors and climate change adaptation: the case of Cameroon. *Forest Policy Econ* 23:1–9. <https://doi.org/10.1016/j.forpol.2012.06.009>
- Tingem M, Rivington M (2009) Adaptation for crop agriculture to climate change in Cameroon: turning on the heat. *Mitig Adapt Strateg Glob Chang* 14:153–168. <https://doi.org/10.1007/s11027-008-9156-3>
- UICN-PC (2015) *Stratégie de Prise en Compte des Femmes dans le Processus REDD+ au Cameroun*. UICN (Union internationale pour la conservation de la nature et de ses ressources), Yaoundé, Cameroun: 73 pages + Annexes
- Van Aelst K, Holvoet N (2016) Intersections of gender and marital status in accessing climate change adaptation: evidence from rural Tanzania. *World Dev* 79:40–50. <https://doi.org/10.1016/j.worlddev.2015.11.003>
- Van den Berg A (1996) *Land right, marriage left: women's management of insecurity in North Cameroon*. Research School CNWS, Leiden University, Leiden
- Yengoh GT, Tchuente A, Armah FA, Odoi JO (2010) Impact of prolonged rainy seasons on food crop production in Cameroon. *Mitig Adapt Strateg Glob Chang* 15:825–841. <https://doi.org/10.1007/s11027-010-9241-2>

**Open Access** This chapter is licensed under the terms of the Creative Commons Attribution 4.0 International License (<http://creativecommons.org/licenses/by/4.0/>), which permits use, sharing, adaptation, distribution and reproduction in any medium or format, as long as you give appropriate credit to the original author(s) and the source, provide a link to the Creative Commons license and indicate if changes were made.

The images or other third party material in this chapter are included in the chapter's Creative Commons license, unless indicated otherwise in a credit line to the material. If material is not included in the chapter's Creative Commons license and your intended use is not permitted by statutory regulation or exceeds the permitted use, you will need to obtain permission directly from the copyright holder.





# Multifunctional Landscape Transformation of Urban Idle Spaces for Climate Resilience in Sub-Saharan Africa

# 107

David O. Yawson, Michael O. Adu, Paul A. Asare, and Frederick A. Armah

## Contents

Introduction .....	2194
The Challenges of Urbanization, Climate Change, and Resilience in Africa .....	2194
Evolution of Urban Landscapes and Idle Spaces in Africa .....	2195
Multifunctional Edible Landscape Approach to Resilience .....	2197
Structure of the Chapter .....	2201
Multifunctional Edible Urban Landscape Transformation in Practice .....	2201
Implementation of the Pilot Project .....	2203
Project Achievement .....	2206
Lessons and Insights for Scaling Up .....	2210
Summary and Conclusions .....	2214
References .....	2216

## Abstract

Poor physical and land use planning underpin the chaotic evolution and expansion in cities and towns in sub-Saharan Africa. This situation amplifies urban vulnerability to climate change. Worse, urban landscapes are rarely considered part of the discourse on urban development in sub-Saharan Africa, let alone in climate change adaptation. Yet, landscapes are known to play crucial roles in social, economic, and cultural resilience in cities and towns. Hence, designing basic forms of appealing and functional urban landscapes that support multiple

D. O. Yawson (✉)

Centre for Resource Management and Environmental Studies, The University of the West Indies, Bridgetown, Barbados

e-mail: [david.yawson@cavehill.uwi.edu](mailto:david.yawson@cavehill.uwi.edu)

M. O. Adu · P. A. Asare

Department of Crop Science, University of Cape Coast, Cape Coast, Ghana

e-mail: [michael.adu@ucc.edu.gh](mailto:michael.adu@ucc.edu.gh); [pasare2@ucc.edu.gh](mailto:pasare2@ucc.edu.gh)

F. A. Armah

Department of Environmental Science, University of Cape Coast, Cape Coast, Ghana

e-mail: [farmah@ucc.edu.gh](mailto:farmah@ucc.edu.gh)

© The Author(s) 2021

W. Leal Filho et al. (eds.), *African Handbook of Climate Change Adaptation*,

[https://doi.org/10.1007/978-3-030-45106-6\\_214](https://doi.org/10.1007/978-3-030-45106-6_214)

2193

ecosystem services is essential to the drive towards resilience, which relates to the ability to maintain or improve the supply of life support services and products (such as food and water) in the face of disturbance. In this chapter, the idea of transforming idle urban spaces into multifunctional edible urban landscapes is introduced and explored as instrumental for cost-effective adaptation and resilience to climate change in cities and towns in sub-Saharan Africa. *Multifunctional edible urban landscape* is defined here as a managed landscape that integrates food production and ornamental design, in harmonious coexistence with other urban structures to promote or provide targeted, multiple services. These services include food security, scenic beauty, green spaces for active living and learning, jobs and livelihoods support, environmental protection, climate adaptation, and overall urban resilience. This approach constitutes a triple-win multifunctional land use system that is beneficial to landowners, city managers, and the general community. This chapter explores the benefits, challenges, and prospects for practically transforming urban idle spaces into multifunctional edible urban landscapes using an example project from Ghana. The chapter shows that multifunctional edible urban landscape transformation for resilience is practically feasible, and sheds light on the possibility of the food production component paying for landscaping and landscape management. It concludes with thoughts on actions required across sectors and multiple scales, including mobilizing stakeholders, laws, policies, and incentives, to actualize multifunctional edible urban landscapes as key transformational components of resilience in sub-Saharan Africa.

---

**Keywords**

Urban landscape · Multifunctional land use · Resilience · Green spaces · Food security · Ecosystem services · Climate change adaptation

---

**Introduction****The Challenges of Urbanization, Climate Change, and Resilience in Africa**

Urbanization has its promise and value in terms of concentrating resources and capital to improve physical development and human well-being; but it has its perils too as it increases the demand for basic necessities of life (such as food, water, shelter, employment, and recreational opportunities) and the complexity of managing the resources and the socioecological processes that underpin ecosystem services and quality of life. Urbanization creates and alters landscape attributes and functions, which in turn affect the environment and quality of life in urban areas. Compared to the rate of urbanization in other regions, Africa is said to have achieved an urbanization miracle (Lwasa 2014). Africa has experienced an unprecedented rate of urbanization in the last two decades, resulting in the emergence of several megacities

(Lwasa 2014; Güneralp et al. 2017). From the year 2010, African urban population has increased at an average rate of 3.2% per year, compared to global average of about 1.2% (African Union 2020; UN DESA 2012). Africa currently has 43% urban population and, together with Asia, will account for about 90% of the projected increase in the world's urban population by 2050 (UN DESA 2019). By mid-century, more than half of Africa's population is expected to live in urban areas. Sub-Saharan Africa will host most of the largest cities that will arise from the projected population growth in Africa, most of them in coastal areas (Di Ruocco et al. 2015). These underscore the challenge and importance of sustainably managing the quality and resilience of urban environment and life by maintaining and enhancing the integrity and functionality of the systems that underpin resilience, particularly food systems (Russo et al. 2017; Haberman et al. 2014).

Already, cities and urban communities in Africa face formidable challenges, including high levels of food insecurity, unemployment, poverty, and environmental degradation (African Union 2020; Lwasa 2014; Güneralp et al. 2017). Provision of livable urban spaces, including green and recreational spaces, has proved particularly challenging and elusive. Increase in food production in Africa has substantially lagged behind the rate of population growth, resulting in protracted food insecurity (African Union 2020). The number of hungry people in Africa is estimated at 256 million and the continent might not meet key global targets on malnutrition or eliminate hunger by 2030 (FAO, ECA and AUC 2020). Projections suggest that an increase of about 112% in food production (over 2015 baseline) will be required to meet the food demand of sub-Saharan Africa alone in 2050 (African Union 2020). Urbanization will not only increase the quantity of food demanded, but also alter the composition and patterns of food consumption, with likely increase in demand for fresh fruits and vegetables. At the same time, urbanization will increase competition with agriculture for land and water which underpin food production.

Climate change presents an additional developmental burden and complicates existing challenges for all regions. However, Africa is considered a highly vulnerable continent to the adverse impacts of climate change (IPCC 2007; Chapman et al. 2017), and the continent is already experiencing the impacts of climate change, through highly frequent and severe episodes of droughts and floods (African Union 2020; Batchelor and Schnetzer 2018; Van Rooyen et al. 2017; Lwasa 2014; Armah et al. 2011). This vulnerability stems partly from Africa's poor physical planning and environmental degradation, and overreliance on agriculture, which is hypersensitive to climate change (IPCC 2007). These challenges raise the imperative for exploring several response options, including the planning, evolution, development, and uses of urban landscapes for reducing vulnerability and enhancing resilience (Russo et al. 2017).

## **Evolution of Urban Landscapes and Idle Spaces in Africa**

Urbanization can be instrumental in amplifying vulnerability or enhancing resilience. Unfortunately, urbanization in Africa is rapid, unplanned, unregulated, and



chaotic (Lwasa 2014; Güneralp et al. 2017), a situation that will compound vulnerability. Especially in sub-Saharan Africa, physical development and land use are poorly planned (if at all). Weak land administration and poor municipal services add to the challenge of discontinuous expansion and poor-quality urban landscapes and environments (Mensah 2014). Urban landscape planning and management are rarely considered important in the discourse on sustainable and resilient development (Yawson 2020). Urban landscapes have, therefore, evolved organically and chaotically with urbanization, and are poorly managed. This poor planning and management of urban landscapes has resulted in the degradation of the biophysical and sociocultural significance of urban communities and diminished the overall resilience to environmental shocks. If this trend remains unaddressed, it can substantially amplify urban challenges and vulnerability to climate change (Di Ruocco et al. 2015). One visible result is the considerable proportion of land surfaces poorly covered by either natural or man-made covers (Mensah 2014). Consequently, very dusty, bushy, and unsightly land surfaces are visible in both the urban core and the periphery, resulting in high exposure to dust during the dry season and mud or sediment transport during the wet season, and other unhealthy elements (Yawson 2020). These have consequences for resilience and sustainability in both the short and long term. For example, long-term exposure to  $PM_{2.5}$  (dominated by dust) can contribute to ischemic heart disease, cerebrovascular disease, lung cancer, and respiratory diseases (Health Effects Institute 2019). The number of deaths associated with  $PM_{2.5}$  in Ghana and Nigeria in 2017 were 5,190 and 49,100, respectively (Health Effects Institute 2019).

Land ownership in Ghana can be used to illustrate the evolution of urban idle spaces in urban landscapes in sub-Saharan Africa. In Ghana, just as in almost all sub-Saharan African countries, urban expansion occurs largely through private action in an informal context. There are two broad types of land ownership in Ghana: customary and state ownership, accounting for 78% and 20%, respectively of total land (Larbi 2008; Yawson and Armah 2018). The remaining 2% are vested lands (split ownership between the state and customary authorities). Customary lands are owned by traditional authorities (stools and skins), clans and families, with chiefs and clan/family heads as the custodians and supported by principal elders of the given community or family (Larbi et al. 2004). The government of Ghana can apply the power of eminent domain to acquire land for national development or security purposes. It is believed that this system of land ownership constrains effective land administration, land use planning and management, and is a major driver of informal land transactions and development. It also partly accounts for the numerous intractable land disputes and conflicts from parcel, through community to tribal scales. Although the Town and Country Planning Department is responsible for physical planning, chiefs or owners of large tracts of land are expected to make and present a parcelled plan of their lands to the Lands Commission for the purposes of registration and titling. However, this is not mandatory or enforced. This means parcelling and layout of residential areas largely evince from landowners, independent of infrastructural and municipal service planning, delivery, and management. This results in incoherent physical development, with scattered pattern of settlements

in developing areas. Due to weak property markets, insecurity of tenure of residential or commercial properties, and weak financial support system for rapid development of individual properties, there is inordinate pressure on land for low-density housing and other commercial activities in urban areas. As a result, persons buy parcels of land and slowly develop these, or simply leave the parcels of land idle until they are financially capable of developing the land. Some also buy land out of speculation, with the view to selling the land later at higher prices. Undeveloped parcels of land do not attract property taxes and there are no mechanisms to ensure management regimes fit for the landscape or the environment. As a result, and partly due to informal planning of space, there are several open spaces and undeveloped or partly developed but idle parcels of land that are poorly managed (if at all) in both the urban core and periphery. These, together with poor infrastructural planning, management, and municipal services, diminish the natural, cultural, and scenic beauty of urban landscapes and escalate vulnerability.

These idle parcels do not only detract from the urban beauty and landscape services, but are also sites for a range of activities, both positive and negative. In some cases, these parcels are used by itinerant farmers for food production, occupied by petty traders or informal settlers (squatters), or simply left bushy or bare and exposed to the erosive forces of water and wind (dust generation and transport). In most cases, these parcels are used for nefarious activities such as littering, defecation, and criminal activities, or habitat for vermin. However, these spaces can be sites for urban greening and human production to transform the landscape to support multiple environmental and developmental goals such as jobs or income generation, food security, environmental protection, and scenic beauty, and thereby contribute to overall urban resilience and well-being.

## **Multifunctional Edible Landscape Approach to Resilience**

Resilient development and adaptation planning have become more urgent for social groups, ecological systems, and geographic regions for which there is high certainty of vulnerability (Stern and Treasury 2007). Resilience has been conceptualized as the capacity of a dynamic system to maintain its structural and functional integrity, or change for the better, in the face of disturbances that threaten the viability, functioning, or development of that system (Masten 2014). Urban resilience, from a socio-ecological perspective, removes constancy and introduces flexible, adaptive, and multilevel approaches for responding to persistent or short-term threats and stresses across the entire urban space. The scale of challenges outlined in section “[The Challenges of Urbanization, Climate Change and Resilience in Africa](#)” constitute a major source of disturbance that threatens the viability, functioning, and development of urban landscapes and communities, deserving resilient, multilevel responses. Globally, landscape-based approaches are being promoted, in both policy and academic circles, as an integral component of the responses to urban sustainability challenges (Säumel et al. 2019; van Noordwijk et al. 2014; Russo et al. 2017; Panagopoulos et al. 2016; Matsuoka and Kaplan 2008).

Landscapes can have different meanings for different persons or professionals (Fischer et al. 2016; Scott et al. 2009). However, in the urban context, landscapes can be considered as the physical environment shaped by human-nature interaction. The “nature” component comprises the biophysical cover of the land surface that underpin ecological productivity, while the “human” component comprises man-made surfaces and structures such as houses, roads, and other infrastructure (Grêt-Regamey et al. 2015; Panagopoulos et al. 2016; Russo et al. 2017), together with human action on nature. These components are intertwined and provide reciprocal services and or feedback effects on each other. Landscapes, therefore, provide first impressions of the complex processes and interactions between social and ecological components that underpin the provision of ecosystem services, which, in turn, underpin human well-being and resilience (Yawson 2020). These ecosystem services are classified as provisioning (e.g., food, herbs, and clean water or air), supporting (e.g., nutrient, energy, or material cycling), regulatory (e.g., flood, erosion, and climate control), and cultural (e.g., heritage, spirituality, visual aesthetics, and recreational opportunities) (Grêt-Regamey et al. 2015). A landscape reflects the status of cultural sophistication, development, and well-being, as well as the vulnerability of its inhabitants or users to a given external or environmental shock (Yawson 2020). Landscapes that are subject to unsustainable management practices can be very vulnerable to shocks and, in turn, deepen the vulnerability of its inhabitants or users to environmental shocks.

Multifunctional edible urban landscapes are being promoted as instrumental for sustainably intensifying the production of ecosystem services and products, improving livelihoods, and optimizing the use of limited land resources as opposed to straight intensification of farming and commercial forestry (Säumel et al. 2019; Panagopoulos et al. 2016; Fischer et al. 2016; Bustamante et al. 2014; van Noordwijk et al. 2014; Santika et al. 2015). Multifunctional edible urban landscape refers to a managed landscape that integrates food production and ornamental landcover, in harmonious coexistence with other urban structures to promote or provide targeted, multiple services such as food, erosion and flood control, scenic beauty, and recreation. A multifunctional edible urban landscape approach, thus, helps generate ecosystem goods and services to meet the basic but multiple demands of urban communities while limiting expansive use of land. It helps reconcile competing interests and goals that put urban land under constant and intense pressure. Multifunctional edible urban landscapes will arise from and be enhanced by land use planning approaches and innovative transformations that harmonize the functions of landscape components in order to derive multiple benefits across varying spatial and temporal scales. Multifunctional edible urban landscapes have considerable promise to contribute to urban resilience and long-term sustainability or adaptive capacity if the structure and functions of components are well aligned, interconnected, and harmonized to generate specific products and services (Säumel et al. 2019; Panagopoulos et al. 2016; van Noordwijk et al. 2014). This implies urban planning should be deliberate in shaping multifunctional landscape performance in order to derive optimal outcomes from every inch of ground. This can be enhanced or constrained by land

use intensity and the scale of opportunity for landscape innovations in existing urban zones. It could be argued that several aspects of landscapes are multifunctional in nature. However, developing countries require special attention for multifunctional landscape planning to impose desirable landscape structure with increased capacity to contribute to addressing the multiple challenges in urban communities in the short term, while enhancing resilience and adaptive capacity in the long term.

Increasingly, this realization has given rise to the calls for expanded urban green infrastructure as a nature-based solution or ecosystem-based approach to resilience and climate change adaptation (Russo et al. 2017). Urban greenspace or cover can contribute to food security, urban aesthetics, thermal regulation, air quality (by suppressing dust and removing pollutants), water quality, and mitigate against flood and erosion (Wolch et al. 2014; Eschobedo et al. 2011; Thompson 2011; Nowak et al. 2006). A review by Laille et al. (2014) showed a strong evidence for contribution to physical and psychological health, biodiversity, thermal regulation, and urban attractiveness. In fact, poor access to urban greenspace could be associated with increased mortality (Coutts et al. 2010) and other adverse health outcomes (e.g., Villeneuve et al. 2012; Thompson 2011; Barton and Pretty 2010). This emerging evidence supports the view on the value and utility of urban green cover to strengthen resilience and adaptation to climate change (Dai 2011). Accordingly, research interests in green infrastructure, ecosystem services, or nature-based solutions have increased substantially as options for strengthening urban sustainability and resilient response to climate change (Haase et al. 2014). While a large body of literature has emerged from this research interest, these studies are largely conducted in isolation without considering the need for integrated systems that include food production and general landscape management in urban contexts (Russo et al. 2017). Critically, in developing countries, the role of human production activities as part of green cover in urban landscapes to support multiple goals, including support for livelihoods, food security, environmental protection and aesthetics, and provision of recreational and learning opportunities, needs to be emphasized (Yawson et al. 2019).

Elsewhere, there have been calls for embedding multifunctionality into agriculture and other land use sectors in rural landscapes (Mander et al. 2007; Nair and Garrity 2012). Even though interest in urban agriculture has been increasing substantially (Csortan et al. 2020; FAO 2012; Urban Agriculture 2009), this has often been studied or articulated in isolation from general landscape management goals. In Africa, the need for deliberately incorporating human production activities in urban landscapes to serve multifunctional purposes is urgent and critical due to increasing urban poverty, food insecurity, and poor-quality landscapes (FAO 2012). Due to poor urban planning, landscapes evolve chaotically with urban development and are hardly managed (Lwasa 2014; Mensah 2014). Poor financial resources and land administration combine to raise the challenge of creating and managing curated landscapes to preserve the scenic beauty and improve the social, economic, environmental, and cultural significance of urban zones. A way out is mobilizing policies, regulations, incentives, and stakeholders to adopt landscape management

approaches that permit a sensible balance between economic activities and profitability on one hand, and ecological functionality and productivity on the other hand, so that the latter is maintained by the former and, together, support overall urban well-being and development goals. In other words, producers become landscape entrepreneurs and managers whose obligation include the maintenance and management of ecological productivity and functionality, profitability, and scenic beauty. In this case, the scenic beauty, which is a desirable public good or noncommodity output, for example, is paid for by the economic production which is private activity (Mander et al. 2007). This twin system can be applied to multifunctional landscapes where food production supports urban food security, jobs, and poverty reduction, while general landscape management, as part of the production obligations, provides ecosystem services such as scenic beauty, environmental protection, and recreational opportunities.

In Africa, innovations in existing urban spaces are required to improve livability and overall resilience and human well-being, through increased capacity for intensive delivery of multiple ecosystem services. Because land is finite and the value of urban land parcels increases rapidly, preserving spaces for a single purpose is extremely difficult (Säumel et al. 2019; Güneralp et al. 2017; Mander et al. 2007). This difficulty is heightened by poor land administration, speculation, informal land transactions, and urban expansion. Additionally, the constraint of funding makes it difficult for African governments to invest in the development and maintenance of curated landscapes to improve the scenic beauty of the urban space and contribute to resilience and well-being. As a result, improving landscape contribution to resilience would require approaches that balance or optimize ecological productivity through human production, economic profitability, and scenic beauty or delivery of other ecosystem services which are public goods. To this end, it is important to adopt innovative approaches to impose specific multifunctional landscape character in existing urban spaces, and multifunctional land use planning for the future. Multifunctional landscape approaches that include human production are promising options for enhancing resilience in poorly planned urban zones in Africa (Säumel et al. 2019). Particularly, food production integrated in properly designed and managed landscapes to support multiple development goals, including food security and jobs, would be crucial. This is particularly important since land is finite, urban land has high value and is constantly under intense pressure from competing interests and goals. Multifunctional edible landscape approach provides opportunity for balancing competing interests and goals, both ecological and socioeconomic, in the African urban space. However, a multistakeholder mobilization of policies, resources, and regulatory and financial instruments will be required to ensure inclusivity, broad-based acceptance, and long-term sustainability (Yawson et al. 2019). The purpose of this chapter is to illustrate the workability and utility of this innovative approach to urban landscape transformation, and the requirements for scaling out, for resilience in Africa using a case study from Ghana.

## Structure of the Chapter

Section “[Introduction](#)” above has provided background and contextual information about urban challenges and evolution of urban landscapes in Africa, as well as the utility of multifunctional edible landscapes for enhancing resilience. The rest of the chapter is organized as following. Section “[Multifunctional Edible Urban Landscape Transformation in Practice](#)” presents a case study of practical implementation of multifunctional edible landscape in existing urban areas in Ghana and the outcomes. Section “[Lessons and Insights for Scaling Up](#)” builds on the case study outcomes to provide lessons and insights on practical expansion of multifunctional edible urban landscapes in Africa. Finally, the chapter presents some conclusions and recommendations in section “[Summary and Conclusions](#)”.

---

## Multifunctional Edible Urban Landscape Transformation in Practice

Promoting innovative landscape transformation can play a catalytic role in addressing urban challenges and enhancing resilience to climate change in Africa. Proceeding from the context and belief presented in the prior section, a practical example of an edible urban landscape transformation activity Ghana is presented in this section. This example is aimed at demonstrating the utility and practical approach to transforming idle spaces into multifunctional edible landscapes in existing urban areas. It also highlights key challenges and levers of change for wider implementation or adoption of this approach to support multiple development goals and enhance resilience. A question of interest inherent in this example was whether the food production component, from a multifunctional perspective, could incentivize and pay for maintenance of scenic beauty and management of landscapes in existing urban areas.

The practical example referred to is derived from a pilot project by the Agriculture for Food Security 2030 (AgriFoSe2030, theme 2) sponsored by the Swedish International Development Agency (SIDA) through the University of Gothenburg. The project, firstly, tested the idea of using vacant, idle parcels of land in the urban area to produce food, enhance the scenic beauty of the surrounding landscape with ornamental plants, while providing jobs for young people and women. This concept was referred to as multifunctional edible urban landscape (a managed landscape that integrates food production, ornamental aesthetics, and other urban structures in a harmonious coexistence to deliver targeted, multiple ecosystem services – Yawson et al. 2019). The edible urban landscape pilot project was conceived as a potential path to climate adaptation and resilience in urban centers in Ghana. The pilot project took place in the year 2018 in the City of Cape Coast in the Central Region of Ghana. Several idle parcels suitable for the project were identified in Cape Coast. Owners of the identified parcels were contacted to negotiate permission to use their lands for the

pilot project. Other considerations for the final selection of sites included trust of landowner, safety of the project activities and assets (for e.g. safety from praedial larceny), access to water, and ease of monitoring by the researchers. Based on these, two sites were eventually secured at Akotokyer ( $1^{\circ}17'36.28''\text{W}$ ,  $5^{\circ} 8'8.61''\text{N}$ ) and Kwaprow ( $1^{\circ}18'7.02''\text{W}$ ,  $5^{\circ} 7'26.98''\text{N}$ ), two communities that border the University of Cape Coast.

The city of Cape Coast is the capital of the Cape Coast Metropolis (CCM) and the Central Region of Ghana. The CCM covers an area of  $122 \text{ km}^2$  and is very urbanized as only 23% of its 169,894 inhabitants live in rural areas (Ghana Statistical Service 2013). The study communities are among several that border the University of Cape Coast and, together, make up the largest spatially distinct continuum of communities outside of the core of the city of Cape Coast which is densely built up and has limited space for new development. Due to the proximity to the University of Cape Coast, Kwaprow and Akotokyer are among the fastest-growing urban communities in Cape Coast as demand for facilities and services for students, staff, and the associated itinerant workers of the University of Cape Coast keeps growing. However, the communities lack planned physical development and so the physical expansion is haphazard and chaotic, with spatially scattered property development and several idle, unmanaged spaces contributing to undesirable landscapes. A section of urban landscape in Kwaprow is shown in Fig. 1. The communities have poor infrastructure and municipal services are vulnerable to floods and are highly exposed to dust pollution during the dry season. This situation presents an opportunity to generate evidence for the value and feasibility of landscape transformation to support multiple development goals and enhance resilience and well-being.

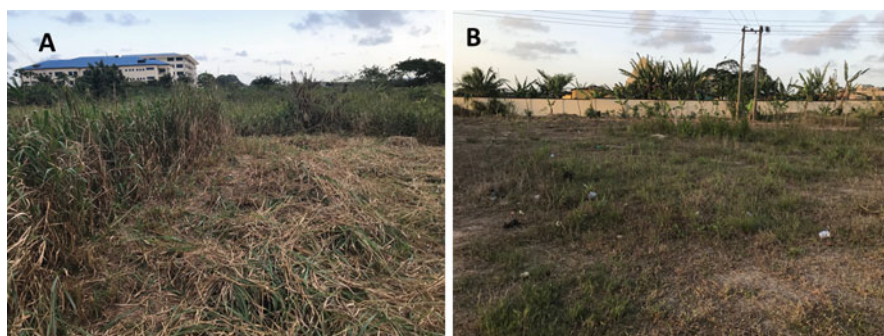


**Fig. 1** A Google Earth screenshot of landscape view of part of Kwaprow community (one of the pilot project communities) in Cape Coast

## Implementation of the Pilot Project

The project goals and activities were explained to relevant stakeholders. The sites for the pilot project were bushy and unkempt (Fig. 2). The site at Akotokyer had sparsely distributed apartment buildings while the site at Kwaprow had neighboring low-density houses and amenities such as a school and a clinic. The sites were cleared, ploughed, and harrowed (Fig. 3).

A greenhouse, measuring  $9 \times 15$  m, was installed at each site (Fig. 4). Solar-powered fans were used for ventilation and to control humidity in the greenhouses. Seedlings of the tomato genotype Eva Purple Ball were grown in pots in the



**Fig. 2** Project site at (a) Akotokyer and (b) Kwaprow



**Fig. 3** Site at Kwaprow (a) and Akotokyer (b) ploughed and prepared for greenhouse installation





**Fig. 4** Greenhouses installed at sites with grasses and border plants grown around the greenhouses

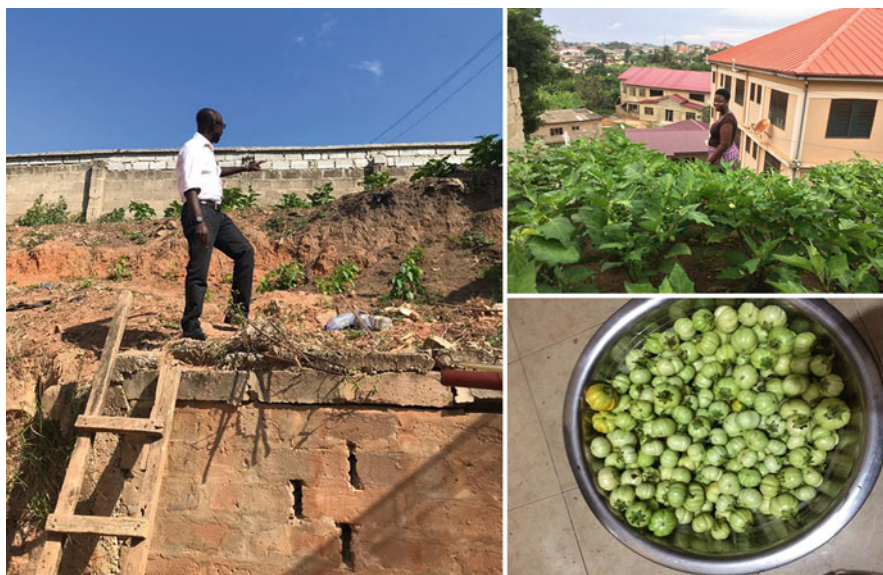


**Fig. 5** Young tomato plants growing in pots in the greenhouses

greenhouses and recommended agronomic practices on integrated production and protection (IPP) were used (Figs. 5 and 6). The area surrounding the greenhouses were planted with grasses and border plants (fruit trees for shade were planned but land lease terms did not permit this immediately) and maintained to improve the scenic beauty of the site, control erosion and dust, while providing recreational and educational opportunities for neighboring families (Fig. 4). Eight young people, four females, and four males aged between 18 and 35 years were employed to work in the greenhouses and to maintain the surrounding landscapes.



**Fig. 6** Matured tomato plants in the greenhouses



**Fig. 7** Degraded, idle backyard space (left) turned into a productive site for eggplant (right)

In addition, the project encouraged individuals to transform small spaces in backyards or urban areas into green, productive areas. For example, one woman turned a degraded, idle backyard space into a productive site for eggplants (Fig. 7).

When the tomatoes were ripe and partly harvested, a stakeholder engagement or dissemination event was held at the sites, involving the communities and other stakeholders, to showcase and discuss the relevance, challenges, and opportunities for scaling up the project (Fig. 8).



**Fig. 8** Segments of stakeholder dissemination event

## Project Achievement

### Multifunctional Edible Urban Landscape

The association between urban greenspaces and environmental quality and human well-being is well established and the need for planning to incorporate greener spaces in urban areas is being actively promoted (Panagopoulos et al. 2016; Laille et al. 2014; Mensah 2014; Bratman et al. 2012; Matsuoka and Kaplan 2008). However, in Ghana, and largely across sub-Saharan Africa, outdoor landscaping is a private matter and overall management of public spaces and the general fabric or structure of the urban landscape does not feature in discourse on sustainable development or resilience. There is evidence that greenspaces in urban Africa is declining at an alarming rate due to neglect and poor land use planning and controls (Mensah 2014). Poor urban landscapes can diminish resilience as they can contribute to flooding and sediment transport, thermal stress, air pollution, garbage accumulation, and transmission of diseases. Landscapes expose most urban residents to environmental conditions that undermine health, well-being, natural resource sustainability, and overall resilience (Säumel et al. 2019). It has been reported that the informal, chaotic, and discontinuous pattern of urbanization in Africa, together with poor social services, is a mark of vulnerability to extreme events (Di Ruocco et al. 2015). Dust, for example, is a major component of particulate matter in the air. In most urban zones and rural communities in Africa, people live literally in dust arising not only from industrial or human activities but mainly from bare surfaces (including roads, see Fig. 1) due to poor physical, infrastructural, and landscape

planning and management. While the adverse health outcomes of exposure to dust are known and have been of considerable interest in some jurisdictions (Khan and Strand 2018), there is poor information on the contribution of dust to air quality and human health in West Africa, for example, where dust pollution and morbidity rates are higher (De Longueville et al. 2010) and over 20% of infant mortality is due to respiratory infections (Bryce et al. 2005; Morris et al. 2003). In the recent state of global air report, it was shown that annual death from air pollution (principally from PM<sub>2.5</sub>) is on the rise in sub-Saharan Africa, reaching 5,190 and 49,100 for Ghana and Nigeria, respectively, in 2017, while others suffer various morbidities due to long-term exposure (Health Effects Institute 2019). Malaria is a major cause of morbidity in the case study communities. Africa remains the largest global hotspot of death from malaria, accounting for about 90% of all deaths from malaria in 2017 (WHO 2018). In addition, heat stress events would likely increase in intensity, frequency, duration, and spatial spread (Chapman et al. 2017) and humid tropical countries could have high sensitivity and exposure to these events. Enhancing resilience in urban communities implies taking verifiable steps to minimize the exposure of populations to these environmental stressors and hazards. Innovative landscape management approaches can help increase infiltration, reduce floods and sediment transport, and exposure to dust and vector-borne diseases such as malaria. These conditions are expected to be amplified by climate change; and taking remedial measures now through cost-effective landscape transformation or management approaches, as demonstrated in this example project, is a reasonable investment in achieving multiple development goals and enhancing resilience and long-term adaptive capacity.

Through their natural, cultural, and scenic beauty, urban landscapes provide a range of services (or disservices) that contribute to social, economic, and cultural resilience and overall quality of life. Landscapes embody and reflect the state of well-being and vulnerability of inhabitants to shocks. Hence, designing basic forms of appealing and functional urban landscapes that support multiple ecosystem services is essential to the drive towards resilience, which relates to the ability to maintain or improve the supply of life support services and products (such as food and water) in the face of disturbance. Just like many cities and towns in Ghana, the evolution of Cape Coast can be described as chaotic, contingent, discontinuous, and informal. Poor planning has combined with pressure on land for housing to create discontinuous physical expansion of the city, resulting in several vacant, idle parcels of land in the city. Several areas in both the core and periphery of the city are degraded, with visible signs of erosion, red-earth (iron-rich) dusty surfaces. Other places are simply covered by unmanaged bush, which becomes breeding grounds for mosquitoes and other vermin. Because of poor drainage systems, the project communities easily succumb to floods and sediment transport (Tham-Agyekum et al. 2019), and have conducive surfaces for breeding of mosquitoes. In the example project presented, the sites acquired for the pilot project were idle, bushy, and unmanaged (Fig. 2), detracting from the scenic beauty and ecological utility of the area, as well as posing physical and health hazards to residents and those who passed through the area, especially women, at night. Residents and those who pass through

the area harbored fear about the high probability of attacks from criminals and/or vermin. There were signs of nefarious use of the sites as litter, human faecal matter, and other vermin were observed during land preparation. This pilot project opened up the area, improved the ecological functions, safety, scenic beauty, and social utility of the area (Figs. 3 and 4). The landscaping around the greenhouses were generally part of the integrated preventive environmental strategy of beautifying and protecting the landscape, reducing environmental degradation by ensuring soil cover and increasing the delivery of ecosystem services, both directly and indirectly. The idea of the project was to maintain a beautiful landscape or urban aesthetics while producing food and supporting incomes for the landscape managers. In this way, food production and basic landscaping are integrated, in a multifunctional edible urban landscape perspective, to deliver multiple ecosystem services. The project sites became attractions to the residents, the communities, and others who simply passed through the area. The grassed surroundings were used for recreational purposes by families and for curiosity learning (especially by children). The project sites became the largest curated, managed outdoor area considered by residents as beautiful and safe space for recreation by children in the communities. Generally, residents and those who passed by were happy about the project as they realized that it is possible to produce so much food in a small area and, at the same time, maintain a beautiful landscape or communal outdoor space in hitherto idle, unmanaged urban areas. The experience from the pilot project reported in this chapter suggests that persons have innate desire for beautiful urban landscapes but are denied of these due to poverty of municipal services. It also suggests the existence of a desire for recreational opportunities in safe, well-kept urban landscapes due to the use of the site for recreational purposes. Some nearby residents were happy because the improved landscape also meant improved security and safety in the area. In all, the example project demonstrated the idea and utility of multifunctional edible urban landscape and the feasibility of achieving this through transformation of idle spaces in existing urban areas.

### **Urban Food Security and Livelihoods**

Food insecurity, unemployment, and poverty are major developmental challenges in urban Africa. Urban poverty is increasing in Africa and so is food insecurity (African Union 2020) as urban areas rely on rural food supplies. With poor supply chains, fresh food deteriorates rapidly both in transit and in urban markets and food safety also becomes a concern. This constrains access to fresh food as availability and prices become affected. Tomato, for example, is a climacteric crop which is an essential ingredient in almost every Ghanaian dish. Tomato is produced under rainfed conditions and long-distance transport and storage under poor conditions result in high losses. Prices of tomato in the dry season can be as high as three to four times the prices in the rainy or main harvesting season. This raises the need for producing food close to urban markets or point of consumption. Although urban agriculture is practiced in Ghana, there are concerns about the safety of the food produced and its environmental impacts due to the quality of water, other inputs, and management practices used (FAO 2012; Redwood 2009). Because urban agriculture

has yet to gain a desirable level of quality and policy attention and thereby become mainstreamed in the urban landscape architecture, urban agriculture is practiced informally and in isolation from landscape management goals (FAO 2012), let alone from a multifunctional perspective. Just as with food, even where municipal services are available, poverty constrains access to these, resulting in increased vulnerability (Armah et al. 2018). Overall, there is a need to boost policy and operational or practical innovations for landscape transformation that integrates urban agriculture and landscape management goals in a singular, cost-effective framework to support resilience to climate change and better response to challenges in existing urban zones. These challenges include food security, jobs and income-generating activities, and aesthetic, livable, and recreational spaces. Embedding human production in the management of urban landscape and scenic beauty in this way is a useful integrative framework for landscape transformation and management as it can ensure that human production pays for the intangible ecological functions and services (such as scenic beauty) that are public goods while enabling a better response to development demands and climate change. This approach is consistent with recent calls for multifunctionality in agriculture, forestry, and other land use sectors (Russo et al. 2017; Nair and Garrity 2012; Mander et al. 2007).

Inherent in the pilot project was the idea of demonstrating the feasibility of twining human production and maintenance of beautiful landscapes such that the former (as a private good or activity) pays for the latter (as a public good) while supporting urban food security. The human production aspect was fulfilled by the production of high-quality tomato fruits in the greenhouses, with low external inputs such as water and pesticides. The system used in the pilot project produces 2000 kg (2 tonnes) tomato per cycle per greenhouse, and there could be at least three cycles per year. If properly planned with market access to high-end users (such as supermarkets, hotels, and restaurants), three cycles are enough to recover the full cost of installation and operation and generate profit. In this project, eight young men and women were employed for the duration of the project, to work in the greenhouses and maintain the surrounding landscapes. Their initial wages were part of the initial investment cost for the first cycle while payment of wages in subsequent cycles would be paid for by revenue from previous cycles. The initial idea was that these young persons work without wages but receive payment from the postharvest revenues. However, this idea was not acceptable to prospective workers, even those who were already in urban farming. So, in the end, their wages had to be worked into the initial investment cost. The tomatoes produced in the greenhouses were sold locally in the study communities, University of Cape Coast and beyond. Those young persons who worked in the greenhouses also had some tomatoes for their own household consumption. This possibility of paying for ecosystem services, as public good, by human production in urban landscapes to support multiple environmental and development goals was demonstrated during the dissemination event, to stakeholders including representatives from the Cape Coast Metropolitan Assembly, Ministry of Agriculture (regional office), town planning, chiefs and elders of the project communities, tomato retailers association in local markets, academics, and the general public. This approach was intensely discussed during the

dissemination event and the consensus was that if this approach is well planned for out- and up-scaling, it can considerably augment urban food security and environmental and human resilience. The members of the project communities indicated how the landscaping could help reduce floods or dust exposure in the communities and improve scenic beauty to bring them some dignity, happiness, and recreational opportunities for children. In all, the project shows a possible pathway for urban employment and livelihoods in food production, landscaping, and landscape management while supporting food security.

Projections suggest that urban food demand will increase substantially due to a combination of increase in population and incomes, increased awareness of food health and safety, and dietary shift (Alexandratos and Bruinsma 2012; Yawson et al. 2020, 2017). A resilient urban community should be food secure and have landscapes that minimize socioecological vulnerability. One way of addressing food safety and security concerns is local supply where the food is transparently produced and freshly supplied to consumers or retailers. Tomato, for example, is almost indispensable in Ghanaian dishes or diets. Tomato production is very seasonal and can be very expensive or simply unavailable during the dry season. Suppliers and market women travel to neighboring countries to bring tomatoes to urban centers in Ghana especially during the dry season. The same can be said of several other vegetables. Yet, there are idle, unkempt spaces in urban areas that currently pose risks and dangers to urban populations and substantially detract from the scenic beauty of urban landscapes. This project demonstrates the fact that a multifunctional edible urban landscape approach can be applied to transform these spaces to productive and livable landscapes to support the multiple goals of food security, jobs and poverty reduction, environmental quality, and human well-being. This approach is not only feasible but also cost-effective and presents a triple-win opportunity for landowners, landscape entrepreneurs and workers, and city managers. It improves landscape structure and ecosystem services to enhance resilience and well-being. In terms of adaptation to climate change, transformation of idle spaces in urban zones to multifunctional edible urban landscapes can be instrumental in strengthening resilience and adaptive capacity in the areas of food insecurity, incomes and livelihoods, and environmental quality.

## **Lessons and Insights for Scaling Up**

Landscaping and maintenance of public outdoor spaces have traditionally been the responsibility of governments. In sub-Saharan Africa, this arrangement seems to be generally absent due to weak financial capability and poor physical planning, resulting in distasteful landscapes that amplify vulnerability to shocks. Although urban agriculture or farming has been practiced for a long time throughout the world, and there is a growing interest and worthy calls for its integration in urban planning (Redwood 2009), it does not necessarily and deliberately integrate landscaping for the purpose of scenic beauty, environmental protection, and recreational use. Similarly, the idea of edible landscapes has been around for a while and practiced in

different formats and context, including home or kitchen gardens and agro-parks. However, in Africa where poor financial capability weakens public landscape management, there is scope for exploring the requirements for creating edible landscape entrepreneurs who simultaneously produce food and maintain aesthetic landscapes, with the former paying for the latter. The practical example presented in this chapter tested this idea in parallel with the idea of transforming the idle spaces to multifunctional edible landscape. This project suggested that young persons would not easily defer payment for their work until revenue is generated from sales of produce. Perhaps, they did not consider the project as their own but only as workers, a situation worthy of further exploration. Nonetheless, on a balance, the project result showed that, with careful planning and successful harvest, it is possible to cover this cost from initial revenue and generate profit from the second or third cycle. Hence, the project gives indication that multifunctional edible landscape entrepreneurs can be developed to maintain idle and public spaces that are poorly managed (or not at all) by either the state or private owners due to inadequate resources. Further exploration of this idea would be useful for policy, practice, and research in multifunctional edible urban landscapes to help improve the general landscape character and resilience of urban zones in Africa.

The project used greenhouse system for crop production. This is expensive and could be unaffordable to potential multifunctional edible urban landscape entrepreneurs who would likely be resource-poor. As a result, some form of financial support or business case could be investigated to inform large-scale implementation of this system. While non-greenhouse-based production systems are viable, such as seen in conventional urban farms, the landscape beautification and opportunities for recreational and educational use might give cause for security concerns. Uncontrolled visit or recreational use of the site can expose the crops to unintentional damages. Prædial larceny could also be increased. In addition, because of the quality and safety concerns over vegetables from urban farms in Ghana (Redwood 2009), greenhouse production might be more acceptable to consumers. Finally, because greenhouse production is highly productive, it will not require large area of land to produce profitably and can be more suitable for small idle spaces or where only a small space can be used for food production while the rest of the land area is landscaped. As a result, the use of a greenhouse system as presented in the example project, or otherwise, should be informed by local circumstances, including security concerns.

While Africa is known to be highly vulnerable to climate change, the local-scale impacts of climate change in Africa is poorly understood (Di Ruocco et al. 2015). Cape Coast lies in the coastal savannah agroecological zone and so drought, water scarcity, and heat stress are persistent problems. Cape Coast is the capital of the Central Region, which is the fourth poorest region in Ghana. These challenges would be exacerbated by climate change, population growth, and urbanization. The urban challenges of Cape Coast might not differ significantly from other cities in Ghana. There are numerous opportunities for implementing multifunctional edible urban landscapes in Ghana and sub-Saharan Africa as the characteristics of urban landscapes tend to be similar. The project demonstrated the promise of a



multifunctional edible urban landscape approach to strengthening resilience through food production, land cover management, improving urban aesthetics, environmental protection, providing greenspace for recreational and educational opportunities, as well as jobs and livelihood opportunities in cities and towns.

Despite the huge potential of this concept of multifunctional edible urban landscape to contribute to resilience and adaptive capacity, there are success factors that need to be in place and challenges that need to be addressed to ensure success. These are discussed below to help identification of opportunities for innovation and mitigation of challenges and risks that might arise, and guide efforts at implementing or scaling up similar landscape transformation projects in similar contexts.

**1) Trust and legitimacy:** The first lever of change is developing a strong trust between city authorities (government), landowners, and landscape entrepreneurs. As indicated earlier, the land sector in Ghana is riddled with disputes, protracted litigation, and conflicts (sometimes violent conflicts) due to poor land administration and inordinate pressure on land for housing, commercial, and industrial activities. A parcel of land can be sold to two or more persons by the same or multiple parties. The courts are unable to deal with land disputes or litigation swiftly. Protecting a parcel of land can be more expensive than the cost of the land itself, and sometimes comes at a great cost to parties in a dispute or conflict. In the example project, though earlier verbal assurances were given by landowners to the researchers, the landowners later showed deep distrust and insecurities with releasing their lands for the project. Urban landowners feel insecure granting their lands for temporary projects as there might be limited or costly paths to peaceful recourse to their lands. The first step to successful implementation of this landscape transformation is, therefore, to establish an institutional framework that fosters and deepens a three-way trust between landowners, city authorities, and landscape entrepreneurs. This institutional framework should formalize and render transparent land transactions and use. This is necessary to legitimize the ownership of resources, the process of transformation, formal rights and responsibilities, and benefits sharing. Minimizing insecurities among landowners and strengthening tenure security of landscape entrepreneurs are key to freeing up the numerous idle spaces in existing urban zones for edible urban landscape transformation projects. This, in turn, will require a stronger connection with and improvements in the land administration system at local or national scale to guarantee the security of ownership and access to land by landowners without jeopardizing the tenure security of those who produce on and manage the landscapes.

**2) Incentives:** Beyond institutional arrangements for land ownership and tenure security, specific incentives can help ease the process of committing idle spaces to edible landscape transformation. As indicated earlier, idle lands do not attract any meaningful taxes and there are no management responsibilities enforced on landowners. There is a need for land management mechanism that encourages owners of idle parcels or spaces to actively manage their lands in a manner that fits the broad urban landscape and ecosystem or transfer such management responsibilities to edible urban landscape initiatives. As part of the institutional arrangements and improvements in land administration, policies and regulatory instruments that

impose and enforce land management and tax obligations on landowners would be essential. This needs to be tightly coupled with improvements in land administration structures and procedures to make the process of land registration and titling less cumbersome. In this context, incentives such as free land registration and/or titling, reduced or waving of land taxes, and transfer of land management responsibilities from landowners to landscape entrepreneurs can help catalyze freeing idle lands for multifunctional edible urban landscape initiatives. Neighbors would be supportive of edible urban landscape projects if they become aware of the numerous benefits it can generate to the public, landowners, and the edible landscapists, especially if neighboring residents know that the project would not lead to conflict over land, and that they can benefit from fresh food, recreational and learning opportunities, or aesthetic value of the project sites. The argument of neighborhood landscape improvement could also be made and used to derive small margin of revenue from neighboring properties whose owners or inhabitants could benefit from the aesthetics and the recreational and educational opportunities. A major incentive to landscape entrepreneurs would be a strong connection to markets: local residents, fresh produce retailers, supermarkets, hotels, restaurants, and processors. Local authorities or city managers could facilitate this as part of an integrated approach to serving the multiple goals of urban development demands, including food security, jobs and poverty reduction, and scenic beauty. This will also mean supporting private or individual developers to complete their housing or property development projects quickly to support the achievement of a desirable landscape as a whole.

**3) Formal edible landscapes in urban planning:** Beyond innovations of landscape transformation in existing urban zones, there is a need to arrest the current chaotic and informal evolution or growth of urban zones and landscapes. This calls for compact urban planning approach that opens up a zone for development at a time, reduces the preponderance of idle spaces, and formally integrates multifunctional edible landscapes in the urban fabric. In the interest of the challenges and threats posed by climate change, resilient cities need to have the capacity for resource efficiency, circular economy, and material transformation or flows. This formal incorporation of multifunctional edible landscapes into the development plan will amount to a formal recognition and practical articulation of the high capacity of urban agriculture for material cycling while supporting multiple socio-ecological services in urban areas (FAO 2012). When greenhouse production is chosen, landscape entrepreneurs might need support as the capital requirement might be high for some. To this end, support for formal access to financial resources and technical support would be helpful and a great incentive to landscape entrepreneurs.

**4) Recognition and articulation of landscape needs and services:** The first challenge is the need for policymakers, regulators, and urban management authorities to recognize and strongly articulate the fact that the appearance and structure of landscapes in which people live are strongly connected to a sense or state of poverty, powerlessness, vulnerability, despondency, ill-health, and distrust of government (Scott et al. 2009). Urban landscapes can deter or facilitate nefarious or some criminal activities. Urban landscapes can confer confidence, dignity, and a sense of pride (or otherwise) in its inhabitants or users. Recognizing these fundamental

relationships between landscapes and people by public authorities is a prerequisite for moving towards policies and management decisions aimed at transforming landscapes to transform lives. People have landscape needs (Matsuoka and Kaplan 2008). These landscape needs are directly linked to the material and existential needs of the landscape inhabitants or users and, by addressing these needs, vulnerability can be reduced, and resilience enhanced (Yawson et al. 2015). A formal recognition and articulation of the linkage between landscapes and urban challenges or people's needs are a prerequisite for innovative planning and transformative approaches that enhance resilience and adaptive capacity. Next to this recognition is the need for political will to tackle the issue of integrated urban planning that can incorporate multifunctional edible urban landscapes, dignity and resilience considerations, or tackle land management in general in urban areas using the approaches or instruments proposed earlier in this chapter. While poverty and undesirable landscapes can have spatial delimitations, their impacts can be diffuse across sectoral, spatial, and temporal scales. The fabric and connectivity of landscapes in urban zones should, therefore, be considered holistically as to ensure broad-based resilience and adaptive capacity across the entire urban space or city. To this end, recognition and articulation of the role of urban landscapes to development and well-being would gain acceptance and support among urban residents and pave the way for mobilizing multiple stakeholders for transformational projects and implementation of planning measures adopted. In Ghana, for example, the Department of Parks and Gardens, which hitherto is responsible for public landscaping and landscape management, seems to be weakened and inactive. Recognizing the link between landscapes and urban resilience and human well-being would also mean revitalizing the appropriate units, such as the Department of Parks and Gardens, Environmental Protection Department, and Agricultural Extension Services, that can provide technical support to landscape entrepreneurs. For example, the Department of Parks and Gardens in Ghana can be a source of genetic or planting materials that helps design the edible landscapes and provides training to prospective landscapists. Context-specific arrangements would be necessary to respond to local challenges or needs. In this way, bottlenecks associated with production and technical assistance in the context of human production and landscape management entrepreneurship can be addressed during planning and operational phases of multifunctional edible landscapes for urban resilience.

---

## Summary and Conclusions

Urban zones in Africa face considerable challenges, including floods, droughts, high rates of poverty, unemployment, food insecurity, and environmental degradation. Climate change, population growth, and urbanization would escalate these challenges. People's landscape needs, poverty, and vulnerability are directly interlinked. This chapter used evidence and insights from a pilot project to promote the feasibility and the instrumental role of a multifunctional edible urban landscape transformation approach that balances land productivity, economic profitability, and

human well-being to strengthen resilience and adaptive capacity in poorly planned or managed urban zones in Africa. The pilot project simply tested the idea and workability of incorporating food production into ornamental landscape design, so that the former pays for the latter while maintaining profitability and supporting urban food security, jobs, and livelihoods, and maintenance of scenic beauty and environmental protection to enhance resilience. The findings from the pilot project show that urban spaces which are hitherto idle, unmanaged, and unkempt can be successfully transformed into green, productive, and aesthetically appealing landscapes to support the delivery of multiple ecosystem services and, therefore, contribute to urban resilience. The example project demonstrated the possibility of producing fresh, quality tomato fruits from a small area using a greenhouse, providing jobs or income for young persons, and maintaining ornamentally landscaped surroundings that provide public goods (scenic beauty, safe space for recreational and learning opportunities, and environmental protection). This demonstrates the workability of this landscape transformation approach to resilience and adaptive capacity using spaces which are currently idle and unmanaged in poorly planned and managed urban zones in Africa. The chapter argues that the multifunctional edible urban landscape transformation approach presented in the example project is innovative, cost-effective, and a feasible avenue for green transformation of undesirable landscapes in sub-Saharan Africa to improve lives and well-being. The multifunctional edible urban landscape transformation in this chapter can be adapted and scaled in similar jurisdictions, where limited public funds constrain investment in landscape and scenic beauty management, so that human production (as a private activity) can pay for public goods or ecosystem services. This idea, which requires further exploration, makes multifunctional edible urban landscape transformation, as presented in this chapter, insightful and relevant for policy, practice, and research. The chapter also sheds light on challenges and levers of change critical for successful transition to multifunctional edible urban landscapes as a pathway to enhancing urban resilience in Africa. These include a formal recognition and articulation of the link between urban landscapes and a sense or state of poverty, powerlessness, and vulnerability of inhabitants. This recognition, coupled with political will and a genuine commitment to confronting the problem, can pave the way for building trust and legitimacy for transforming idle spaces, providing incentives for landscape transformation project, and formally incorporating multifunctional edible landscapes in compact urban development planning and processes. Achieving this will, in turn, require multistakeholder mobilization of policies, laws, and institutional arrangements that (i) ease access to idle or formally demarcated spaces in urban zones in a manner that protects or guarantees the security of ownership and tenure for both land owners and landscape entrepreneurs, (ii) incentivizes multifunctional edible urban landscapes in the context of urban planning and management for resilience and adaptation to climate change, (iii) provides support for access to productive and technical resources, and (iv) promote reliable market for produce from multifunctional edible urban landscapes to sustain the human production and the payment for the ecosystem services which are public. Altogether, the landscape transformation approach presented in this chapter demonstrates an innovative path that balances

ecological productivity and protection, scenic beauty, and socioeconomic profitability and well-being in existing urban zones, and constitutes a triple-win option for urban managers, landowners, and landscape entrepreneurs. If well planned and effectively managed, it can enhance urban resilience and contribute to long-term sustainability of urban zones in Africa. Hence, multifunctional edible urban landscapes should be integral to the suite of responses to the challenges of climate change.

## References

- African Union (2020) Framework for irrigation development and agricultural water management in Africa. African Union Commission, Addis Ababa
- Alexandratos N, Bruinsma J (2012) World agriculture towards 2030/2050: the 2012 revision. ESA working chapter no. 12-03. Food and Agriculture Organization (FAO) of the United Nations, Rome
- Armah FA, Odoi JO, Yengoh GT, Obiri S, Yawson DO, Afrifa EKA (2011) Food security and climate change in drought-sensitive savanna zones of Ghana. *Mitig Adapt Strateg Glob Chang* 16:291–306
- Armah FA, Ekumah B, Yawson DO, Odoi JO, Afitiri A-R, Nyieku FE (2018) Access to improved water and sanitation in sub-Saharan Africa in a quarter century. *Heliyon* 4:e00931. <https://doi.org/10.1016/j.heliyon.2018.e00931>
- Barton J, Pretty J (2010) What is the best dose of nature and green exercise for improving mental health? A multi-study analysis. *Environ Sci Technol* 44(10):3947–3955
- Batchelor C, Schnetzer J (2018) Compendium on climate-smart irrigation: concepts, evidence and options for a climate-smart approach to improving the performance of irrigated cropping systems. Global Alliance for ClimateSmart Agriculture, Rome
- Bratman GN, Hamilton JP, Daily GC (2012) The impacts of nature experience on human cognitive function and mental health. *Ann N Y Acad Sci* 1249:118–136. <https://doi.org/10.1111/j.1749-6632.2011.06400.x>
- Bryce J, Boschi-Pinto C, Shibuya K, Black RE (2005) The WHO child health epidemiology reference group. WHO estimates of the causes of death in children. *Lancet* 365:1147–1152
- Bustamante M, Robledo-Abad C, Harper R, Mbow C, Ravindranath NH, Sperling F, Haberl H, Pinto AD, Smith P (2014) Co-benefits, trade-offs, barriers and policies for greenhouse gas mitigation in the agriculture, forestry and other land use (AFOLU) sector. *Glob Chang Biol* 20:3270–3290
- Chapman S, Watson JEM, Salazar A, Thatcher M, McAlpine CA (2017) The impact of urbanization and climate change on urban temperatures: a systematic review. *Landsc Ecol* 32:1921–1935. <https://doi.org/10.1007/s10980-017-0561-4>
- Coutts C, Horner M, Chapin T (2010) Using geographical information system to model the effects of green space accessibility on mortality in Florida. *Geocarto Int* 25(6):471–484
- Csortan G, Ward J, Roetman P (2020) Productivity, resource efficiency and financial savings: an investigation of the current capabilities and potential of South Australian home food gardens. *PLoS One* 15(4):e0230232. <https://doi.org/10.1371/journal.pone.0230232>
- Dai D (2011) Racial/ethnic and socioeconomic disparities in urban green space accessibility: where to intervene? *Landsc Urban Plan* 102(4):234–244
- Di Ruocco A, Gasparini P, Weets G (2015) Urbanization and climate change in Africa: setting the scene. In: Pauleit S et al (eds) *Urban vulnerability and climate change in Africa*. Future city, vol 4. Springer, Geneva, pp 1–35. [https://doi.org/10.1007/978-3-319-03982-4\\_1](https://doi.org/10.1007/978-3-319-03982-4_1)
- Eschobedo FJ, Kroeger T, Wagner JE (2011) Urban forests and pollution mitigation: analyzing ecosystem services and disservices. *Environ Pollut* 159(8):2078–2087
- FAO (2012) *Growing greener cities in Africa*. First status report on urban and peri-urban horticulture in Africa. Food and Agriculture Organization (FAO) of the United Nations, Rome

- FAO, ECA, AUC (2020) Africa regional overview of food security and nutrition 2019. Food and Agriculture Organization (FAO) of the United Nations, Accra. <https://doi.org/10.4060/CA7343EN>
- Fischer AP, Vance-Borland K, Jasny L, Grimm KE, Charnley S (2016) A network approach to assessing social capacity for landscape planning: the case of fire-prone forests in Oregon, USA. *Landsc Urban Plan* 147:18–27
- Ghana Statistical Service (2013) 2010 population and housing census: District analytical report - Cape Coast Municipality. Ghana Statistical Service, Accra, Ghana
- Grêt-Regamey A, Weibel B, Kienast F, Rabe S-E, Zülrian G (2015) A tiered approach for mapping ecosystem services. *Ecosyst Serv* 13:16–27
- Güneralp B, Lwasa S, Masundire H, Parnell S, Seto KC (2017) Urbanization in Africa: challenges and opportunities for conservation. *Environ Res Lett* 13:015002
- Haase D, Larondelle N, Andersson E et al (2014) A quantitative review of urban ecosystem service assessments: concepts, models, and implementation. *Ambio* 43(4):413–433. <https://doi.org/10.1007/s13280-014-0504-0>
- Haberman D, Gillies L, Canter A, Rinner V, Pancrazi L, Martellozzo F (2014) The potential of urban agriculture in Montréal: a quantitative assessment. *ISPRS Int J Geo Inf* 3(3):1101–1117. <https://doi.org/10.3390/ijgi3031101>
- Health Effects Institute (2019) State of global air 2019. <http://www.stateofglobalair.org>. Accessed 18 Sep 2019
- IPCC (2007) Climate change 2007: impacts, adaptation and vulnerability. Contribution of working group II to the fourth assessment report of the Intergovernmental Panel on Climate Change (IPCC). Cambridge University Press, Cambridge, UK
- Khan RK, Strand MA (2018) Road dust and its effect on human health: a literature review. *Epidemiol Health* 40:e2018013. <https://doi.org/10.4178/epih.e2018013>
- Laille P, Provendier D, Colson F (2014) The benefits of urban vegetation: a study of the scientific research and method of analysis. *Plante & Cité*, February 2014, 28 p. [https://www.plante-et-cite.fr/data/beneveg\\_english\\_bd.pdf](https://www.plante-et-cite.fr/data/beneveg_english_bd.pdf). Accessed June 22, 2020
- Larbi WO (2008) Compulsory land acquisition and compensation in Ghana: searching for alternative policies and strategies. FIG/FAO/CNG International Seminar on State and Public Sector Land Management, Verona, Italy, September 9–10, 2008, 21 p. [http://www.fig.net/commission7/verona\\_fao\\_2008/chapters/09\\_sept/4\\_1\\_larbi.pdf](http://www.fig.net/commission7/verona_fao_2008/chapters/09_sept/4_1_larbi.pdf). Accessed 4 Dec 2013
- Larbi WO, Antwi A, Olomolaiye P (2004) Compulsory land acquisition in Ghana: policy and praxis. *Land Use Policy* 1(2):115–127
- De Longueville F, Hountondji Y-C, Henry S, Ozer P (2010). What do we know about effects of desert dust on air quality and human health in West Africa compared to other regions? *Sci Total Environ* 409(1):1–8
- Lwasa S (2014) Managing African urbanization in the context of environmental change. *Interdisciplina* 2(2):263–280
- Mander Ü, Helming K, Wiggering H (eds) (2007) Multi-functional land use: meeting future demands for landscape goods and services. Springer-Verlag Berlin Heidelberg, Berlin, 13 p. Ch. 1
- Masten AS (2014) Ordinary magic: resilience in development. Guilford Press, New York
- Matsuoka RH, Kaplan R (2008) People needs in the urban landscape: analysis of Landscape and Urban Planning contributions. *Landsc Urban Plan* 84(1):7–19
- Mensah CA (2014) Urban green spaces in Africa: nature and challenges. *Int J Ecosyst* 4(1):1–11
- Morris SS, Black RE, Tomaskovic L (2003) Predicting the distribution of under-five deaths by cause in countries without adequate vital registration systems. *Int J Epidemiol* 32:1041–1051
- Nair PKR, Garrity D (eds) (2012) Agroforestry – the future of global land use. Springer, Dordrecht
- Nowak DJ, Crane DE, Stevens JC (2006) Air pollution removal by urban trees and shrubs in the United States. *Urban Forest Urban Green* 4:115–123
- Panagopoulos T, Duque JAG, Dan MB (2016) Urban planning with respect to environmental quality and human well-being. *Environ Pollut* 208:137–144
- Redwood M (ed) (2009) Agriculture in urban planning: generating livelihoods and food security. Earthscan and IDRC, Sterling

- Russo A, Escobedo FJ, Cirella GT, Zerbe S (2017) Edible green infrastructure: an approach and review of provisioning ecosystem services and disservices in urban environments. *Agric Ecosyst Environ* 242:53–66
- Santika T, Meijaard E, Wilson KA (2015) Designing multi-functional landscapes for forest conservation. *Environ Res Lett* 10:114012
- Säumel I, Reddy SE, Wachtel T (2019) Edible city solutions – one step further to foster social resilience through enhanced socio-cultural ecosystem services in cities. *Sustainability* 11(4):972
- Scott AJ, Shorten J, Owen R, Owen I (2009) What kind of countryside do the public want: community visions from Wales UK? *GeoJournal*. <https://doi.org/10.1007/s10708-009-9256-y>
- Stern N, Treasury G (2007) *The economics of climate change: the Stern review*. Cambridge University Press, Cambridge, UK
- Tham-Agyekum EK, Okorley EL, Amamoo FA (2019) Alternative livelihood support for reducing poverty: snail project for Kwaprow Community in Cape Coast. *J Advocacy Res Educ* 6(2):33–39
- Thompson CW (2011) Linking landscape and health: the recurring theme. *Landsc Urban Plan* 99: 187–195
- UN DESA (2012) *World urbanization prospects: the 2011 revision*. United Nations Department of Economic and Social Affairs, Population Division, United Nations, New York. <http://esa.un.org/unup/CD-ROM/Urban-rural-Population.htm>. May 29, 2017
- UN DESA (2019) *World urbanization prospects: the 2018 revision*. ST/ESA/SER.A/420. United Nations, Department of Economic and Social Affairs, Population Division, New York
- Urban Agriculture (2009) *Building resilient cities*. *Urban Agriculture Magazine* 22, June 2009, 56 p
- van Noordwijk M, Agus F, Dewi S, Purnomi H (2014) Reducing emissions from land use in Indonesia: motivation, policy instruments and expected funding streams. *Mitig Adapt Strateg Glob Chang* 19:677–692
- Van Rooyen AF, Ramshaw P, Moyo M, Stirzaker R, Bjornlund H (2017) Theory and application of Agricultural Innovation Platforms for improved irrigation scheme management in Southern Africa. *Int J Water Res Dev* 33(5):804–823
- Villeneuve PJ, Jerret M, Su JG et al (2012) A cohort study relating urban green space with mortality in Ontario, Canada. *Environ Res* 115:51–58
- WHO (2018) *World malaria report 2018*. World Health Organization, Geneva. <https://apps.who.int/iris/bitstream/handle/10665/275867/9789241565653-eng.pdf?ua=1>. Accessed 1 July 2020
- Wolch JR, Byrne J, Newell JP (2014) Urban green space, public health, and environmental justice: the challenge of making cities ‘just green enough’. *Landsc Urban Plan* 125:234–244
- Yawson DO (2020) Quantifying perceived landscape desirability in human settlements: the case of four communities in Cape Coast, Ghana. *Ghana J Geogr* 12(1):74–98
- Yawson DO, Armah FA (2018) Alienation and conflicts in protected forest resource exploitation in Ghana: who or what is legal? *Proceedings of the Cave Hill Philosophy Symposium, Conversation XIII, The University of the West Indies, Barbados* 13(1), 22 p
- Yawson DO, Adu MO, Armah FA, Kusi J, Ansah IG, Chiroro C (2015) A needs-based approach for exploring vulnerability and response to disaster risk in rural communities in low income countries. *Australas J Disaster Trauma Stud* 19:27–36
- Yawson DO, Mulholland BJ, Ball T, Adu MO, Mohan S, White PJ (2017) Effect of climate and agricultural land use changes on UK feed barley production and food security to the 2050s. *Land* 6(4):74. 14pp
- Yawson DO, Adu MO, Asare PA, Armah FA (2019) *Prospects and challenges of edible urban landscapes in Ghana*. An AgriFose2030 research brief, University of Cape Coast (Ghana) and University of Gothenburg (Sweden)
- Yawson DO, Mohan S, Armah FA, Ball T, Mulholland B, Adu MO, White PJ (2020) Virtual water flows under projected climate, land use and population change: the case of UK feed barley and meat. *Heliyon* 6:e03127

**Open Access** This chapter is licensed under the terms of the Creative Commons Attribution 4.0 International License (<http://creativecommons.org/licenses/by/4.0/>), which permits use, sharing, adaptation, distribution and reproduction in any medium or format, as long as you give appropriate credit to the original author(s) and the source, provide a link to the Creative Commons license and indicate if changes were made.

The images or other third party material in this chapter are included in the chapter's Creative Commons license, unless indicated otherwise in a credit line to the material. If material is not included in the chapter's Creative Commons license and your intended use is not permitted by statutory regulation or exceeds the permitted use, you will need to obtain permission directly from the copyright holder.







# Climate Change Impact and Adaptation: Lagoonal Fishing Communities in West Africa

# 108

K. Sian Davies-Vollum, Debadayita Raha, and Daniel Koomson

## Contents

Introduction .....	2222
Lagoon Environments and Communities .....	2224
Lagoon Environments .....	2224
Lagoon Communities .....	2225
Impacts of Climate Change on Lagoons and Lagoon Communities .....	2226
Sea Level Rise .....	2226
Flood Risk .....	2227
Rainfall and Temperature .....	2227
Vulnerability of and Adaptation to Climate Change in Lagoon Fishing Communities .....	2228
Community-Level Autonomous Adaptations .....	2229
Understanding Vulnerability for Effective Adaptation Planning: Muni Lagoon Case Study ...	2233
Policy Implementation and Participatory Governance .....	2235
International Policies and Frameworks Influencing Coastal Governance and Policy .....	2236
Regional Frameworks and Governance .....	2237
National-Level Coastal and Climate Change Policy Mechanisms .....	2238
Adaptation to Climate Change in Coastal Communities: The Policy Gap .....	2240
Participatory Governance .....	2241
Summary .....	2242
References .....	2242

This chapter was previously published non-open access with exclusive rights reserved by the Publisher. It has been changed retrospectively to open access under a CC BY 4.0 license and the copyright holder is “The Author(s)”. For further details, please see the license information at the end of the chapter.

K. S. Davies-Vollum (✉) · D. Raha · D. Koomson  
Environmental Sustainability Research Centre, University of Derby, Derby, UK  
e-mail: [s.davies-vollum@derby.ac.uk](mailto:s.davies-vollum@derby.ac.uk); [d.raha@derby.ac.uk](mailto:d.raha@derby.ac.uk); [d.koomson@derby.ac.uk](mailto:d.koomson@derby.ac.uk)

---

**Abstract**

Lagoons are a common feature of the low-lying West African coastline. These lagoons are resource-rich and biodiverse. The small-scale fishing communities, which border them, are dependent on the resources and ecosystem services for their livelihoods and well-being. Climate change has had significant and diverse effects on both the lagoons and their surrounding communities. Sea level rise has caused erosion of the coast and increased the risk of floods. Changes to rainfall patterns have caused shifts in lagoon ecosystems and physical cycles. Of particular relevance to lagoon fishing communities is the fluctuation in quantity and distribution of fish catch that they rely upon for economic livelihood. Understanding the vulnerability of these communities to the effects of climate change is critical to supporting and developing successful adaptations. Using a case study from Ghana, sustainable livelihoods approach (SLA) and vulnerability framework are used to characterize the community vulnerability, giving insight into the temporal and spatial dynamics of vulnerability and how subsections of the community may be identified and prioritized for adaptation interventions. A scalar analysis of the relevant coastal and environmental frameworks and policy to support climate change adaptation in coastal communities reveals the common challenges in implementing adaptation interventions and strategies in the region. A policy gap exists between high level, institutional coastal, and climate directives and implementation of climate adaptations at the local level. That gap might be bridged by a participatory approach that places coastal communities at the center of creating and enacting climate change adaptations.

---

**Keywords**

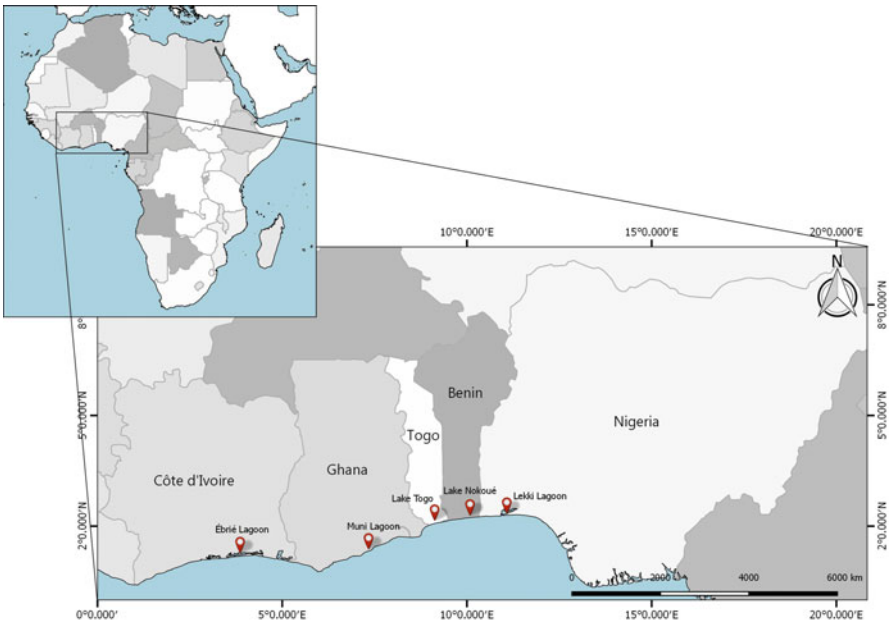
Lagoon · Vulnerability · Adaptation · Fishing communities

---

**Introduction**

Coastal lagoons, and the wetlands that are often associated with them, are estimated to occupy 13% of coastlines worldwide (Duck and De Silva 2012). They are found at low-lying, sandy coastlines where they support highly productive ecosystems that provide a wide range of natural functions and ecosystem services to the communities living around them. Lagoons along African coastlines are often home to fishing communities, whose livelihoods are entirely dependent on the resources supplied by them. In West Africa, lagoon communities take advantage of highly productive coastal fisheries that are supported by upwelling along the Gulf of Guinea, which brings nutrients to surface waters. The fishing communities here tend to fish in both shallow coastal waters and coastal lagoons (also known as coastal lakes). Climate change is affecting lagoons and the fishing communities

that live around them, in multiple interconnected ways. Sea level rise has eroded coastal land and increased the risk of flood. Changes to rainfall and temperature patterns have altered natural lagoon cycles and coastal ecosystems. The resultant changing ocean and lagoon conditions have altered fish catch and fishing practice. The effects of climate change thus have significant implications for the well-being and livelihood of lagoon fishing communities. Understanding how climate change affects lagoon fishing communities is critical to supporting and developing successful adaptations. In this chapter, the impacts of climate change on the lagoons of West Africa, specifically in Cote d'Ivoire, Ghana, Benin, Togo, and Nigeria (Fig. 1), and the fishing communities they support are discussed. How the vulnerability of these communities is characterized, assessed, and connected to climate change is explored. A case study of a fishing community in Ghana is used to exemplify how understanding vulnerability is critical for effective and nuanced community-level adaptation planning. Current international, regional, and national frameworks, governance, and policy to support the creation and implementation of successful adaptation strategies for lagoon communities are presented. The gap between coastal- and climate-related policy and successful implementation of adaptations to climate change in coastal communities is considered and the participatory approach required to bridge that gap presented.



**Fig. 1** Map of West African coastal countries with key urban area and lagoons shown

## Lagoon Environments and Communities

### Lagoon Environments

Lagoons are highly dynamic coastal environments, vulnerable to changes in oceanic and meteorological conditions associated with climate change. They are bodies of coastal water fully or partially separated from the open ocean by a natural barrier. This barrier is of low elevation, often less than two meters above sea level, and consists of sand that is easily eroded and transported. Lagoon barriers can entirely separate the lagoon from the ocean, or they can have one or more breaks, known as breaches or tidal inlets, which connect the lagoon to the ocean. The breaks are important as they act as channels that allow ocean water and biota to enter the lagoon. The barriers can change from whole to breached, and vice versa, in response to variations in weather conditions, hydrological conditions, availability of sediment, and sea level. A seasonal cycle of opening and closing of the sand barriers is common. Natural breaching usually results from overtopping of the barrier from the lagoon when the lagoon is full of freshwater at the end of rainy season. The opening of a lagoon to the ocean allows seawater to flow into the lagoon, resulting in rapid shifts in water temperature, salinity, dissolved oxygen content, and concentration of anthropogenic pollutants. Opening can also alter the tidal amplitude and influence in the lagoon as well as the amount and location of erosion and sediment deposition. Opening can also have an effect on the incidence, amount, and location of flooding. Such fluctuations in the physical environment can create unstable and stressful conditions for lagoon organisms at the species, community, and ecosystem level that can then negatively affect their health and productivity. This in turn influences the availability of natural resources, including fisheries.

Lagoons, or coastal lakes as they are sometimes known in the region, are found at low-lying coastal areas throughout Africa. Along the West African coastline of focus here, there are more than 200 lagoons from Cote d'Ivoire to western Nigeria. This coastline experiences the Guinea Ocean current, which flows from west to east along the west-east trending coastline, creating similar ocean conditions in the region. The lagoons along this coastline vary in size and shape as well as the nature of their connection to the ocean. Two of the largest are Lake Nokoué in Benin and the Lekki Lagoon complex in Nigeria (Fig. 1). Lake Nokoué lagoon covers an area of 120 km<sup>2</sup>. A former estuary of the Ouémé River, a sand barrier has now enclosed the estuary (Anthony et al. 2002), preventing permanent connection to the sea. The Lekki-Lagos lagoon complex in Nigeria parallels the coastline for approximately 200 km (Bernacsek et al. 1990) incorporating two separate lagoons: the Lekki and Lagos lagoons. The majority of lagoons, however, in the region are much smaller than these two, with an areal extent from a few to tens of square kilometers.

Lagoons have high biodiversity in tropical and subtropical regions and are often the site of species-rich wetlands. West African lagoons are no exception with high productivity and biodiversity. The key natural resources of these biodiverse lagoons are fisheries and mangroves. According to the USAID, lagoon settings play a key role to fisheries in the area and have been recognized as contributing \$400 million

annually to the regional economy (USAID 2014). However, the West Africa Regional Fisheries Program (WARFP) indicates that incomes for artisanal (small-scale) fishers have dropped by as much as 40% over the last decade (The World Bank 2015). This has knock-on effects for the livelihood and well-being of these small-scale fishing (SSF) communities, with the potential to increase their vulnerability to the impacts of climate change. Mangroves are the key lagoon wetland vegetation and provide a variety of ecosystem services: shoreline protection and storm buffering through trapping sediment and dissipating wave energy, regulation of water quality, and provision fish habitats and nurseries (Blankespoor et al. 2014). Through the ecosystem services they provide, mangroves are estimated to contribute approximately 3 billion US dollars annually to the West African economies (Boateng 2018). Despite the importance of mangroves to lagoon communities, they have been decimated due to overexploitation, clearance, and pollution (Boateng 2018; Djihouessi et al. 2016). The impacts of climate change at the coast (sea level rise, changes to temperature, shifts in rainfall patterns, and increased storminess) have further contributed to their demise.

## Lagoon Communities

Coastal towns are Africa's most developed, most densely populated urban areas (State of African Cities 2008), and migration to the coast has been and remains a long-term trend (Ochiewo 2004). The major cities of Abidjan (Cote d'Ivoire), Accra (Ghana), Cotonou (Benin), Lome (Togo), and Lagos (Nigeria) are all situated around one or more lagoons (Fig. 1). Cote d'Ivoire has a coastal population of 8.2 million, which accounts for 36% of its total population (World Bank 2019). The economic capital and largest urban area of Cote d'Ivoire is Abidjan, which is built around the Ébrié Lagoon. Seventy percent of Ghana's approximately 25 million population (Ghana Embassy 2014) lives in the southern part of the country with maximum population density at the coast. The Korle Lagoon has played a significant role in the development of its capital, Accra. Benin has a short coastline compared to the total area, yet half of its population live in Cotonou, the capital, which is located around Lake (lagoon) Nokou (World Bank 2019). In Togo, the City of Lome lies on the eastern shores of Lake (lagoon) Togo. Lagos, Nigeria's largest city, sits on the Western shores of Lagos Lagoon, part of the Lekki lagoon-barrier system. These lagoons have been an important source of natural resources, including fisheries, supporting the development of the surrounding urban areas. Fishing communities have traditionally lived around the shores and along the lagoon barriers of these highly urbanized areas. Despite the rapid growth and population increase of urban coastal areas, fishing communities still have a strong presence. For example, in Cotonou fishing remains a mainstay of the economy (Dossou and Glehouenou-Dossou 2007). Lagoons located in less urbanized (rural or peri-urban) areas of the coast are also home to large numbers of small fishing communities. Between 40% and 45% of the rural work force of Lagos State of Nigeria engage in SSF, and it is the dominant type of employment (Akanni 2010). At Aby Lagoon in the Cote d'Ivoire,

fishing is noted as the most important activity for the economy and livelihood of families in the region (Njifonjou et al. 2006), and in Ghana 66.5% of household livelihood activities in coastal communities are classified as fisheries-based (Evadzi et al. 2018). No matter where they are located, whether in urban or rural areas, these fishing communities are dependent on lagoon and ocean fish stocks for their livelihood and food security. In addition, lagoon fishing communities depend on the myriad ecosystem services that a lagoon system provides such as water resources, flood mitigation, washing and bathing, and wood resources, all of which are subject to the impacts of a changing climate.

---

## Impacts of Climate Change on Lagoons and Lagoon Communities

### Sea Level Rise

Climate change negatively affects lagoons and the communities they support through sea level rise, changes to rainfall, and increased ocean and air temperatures. During the twentieth century, global average sea level rose by 3.2 mm/year (Rahmstorf 2007). During the twenty-first century, rates of SLR are expected to increase with estimates varying greatly from 0.4 meters to 2.5 meters (Hauer et al. 2019). Historic data for SLR in Africa has been limited, and its impacts have been understudied across the continent at both national and sub-national levels (Brown et al. 2011). However, there are an increasing number of studies relating to SLR and its impacts along the coast of West Africa. Coastal management in Ghana has focused on physical processes; thus, most information on SLR and erosion in the region is from here. The average rate of sea level rise over the twentieth century measured at the Takoradi tidal station in western Ghana is 3.34 mm/year (Sagoe-Addy and Appeaning Addo 2013), and by inference, the rate along this coastline is likely to be similar. Evadzi et al. (2018) noted that on average, sea level in Ghana has risen by about 5.3 cm over the last 21 years, and SLR accounted for approximately 31% of the observed annual coastal erosion rate (approximately 2 m/year) in Ghana. The lagoon-barrier coastlines of West Africa are particularly susceptible to erosion associated with SLR because of their low coastal topography and their composition of loose, easily erodible sand. Sea level rise can cause erosion of lagoon barriers, increasing the probability of lagoon opening to the ocean. Average rates of coastal erosion for the coastline between Cote d'Ivoire and Nigeria are around 1.5 meters/year (World Bank 2019; Wiafe 2010). However, rates of erosion vary greatly along the coast with erosion hotspots recording more rapid shoreline loss. In eastern Ghana, close to the border with Togo, rates of erosion of up to 3.9 m/year have been recorded (Boateng 2012), and up to 4 meters/year has been recorded along parts of Benin's coastline (World Bank 2019). High rates of erosion have also been observed near the Lekki lagoon, along Nigeria's lagoon-barrier coast (Danladi et al. 2017). At all these locations, rates of erosion are often exacerbated by the loss of mangroves (Diop and Sherin 2016; Boateng 2018), and in a negative feedback loop, coastlines with high erosion rates often experience increased

mangrove loss as the root structures of the plant become compromised due to the loss of substrate through erosion. Erosion associated with SLR affects not only natural coastlines, including the lagoon barrier integrity, but also the stability of human structures. This includes dwellings but also fishing-related structures. In Ghana, the loss of fish landing sites in Accra is already recognized (Apeaning-Addo 2014) resulting in the collapse of artisanal fishing.

## **Flood Risk**

Flood risk for lagoon communities is enhanced by sea level rise, and there are multiple examples of this recorded for the countries considered here. Several Nigerian coastal states are recognized as having high flood risk for an SLR of less than a meter with the barrier lagoon coast of Lagos-Badagry-Seme in the southwestern part of Nigeria noted as particularly vulnerable (Odunga et al. 2014). Also in Nigeria, flooding and associated intrusion of salt water from the ocean have been recorded at the Lekki lagoon-barrier system since the early 1990s (Awoskia and Ibe 1993). The lagoon at Abidjan was highlighted as having a high risk of flooding associated with SLR (Adelekan 2010). In Ghana's central coast, a study of the Muni Lagoon indicated that a 1 meter rise in sea level would almost completely submerge its barrier and inundate the lagoon (Davies-Vollum and West 2015). The poorest communities are those most at risk from flooding, which includes those engaged in SSF. Temporary relocation is the main strategy adopted by members of the communities to adapt to coastal flooding. Some communities also use cheap materials for the construction of their houses as an adaptation to minimize economic loss during inundation (Evadzi et al. 2018). Increased water salinity associated with SLR and inundation inhibits biota in coastal ecosystems, including mangroves, and in a study of coastal wetlands in LEDCs, Blankespoor et al. (2014) estimated that up to 68% of these would be lost if subject to a 1 m rise in sea level.

## **Rainfall and Temperature**

Rainfall projections for the West African coast indicate that during the twenty-first century, precipitation will become extreme with dry seasons becoming drier and wet seasons wetter. Along the West African coast, the major rainy season occurs from approximately March to July, with some geographic variation. Precipitation changes for West Africa include a projected variability in seasonal monsoonal rains (Adeniyi 2016), and there is evidence that the timing and amount of rain that falls during the rainy season have changed (Dossou and Glehouenou-Dossou 2007). In southwestern Nigeria, the rainy season appears to have shifted from March–November to May–October (Adelekan and Fregene 2015), and in Ghana, there seems to be less predictability in the onset of monsoonal rains (Koomson et al. 2020). Changes to the amount and timing of precipitation during the rainy seasons can modify the amount of freshwater input to lagoons and disturb the natural cycle of lagoon

opening. Increased rainfall during the wet season results in more water impounded behind the barrier. This not only causes flooding but also increases the probability of lagoon waters overtopping and/or breaking through the barrier. Rainfall that is more evenly distributed throughout the year results in decreased risk of overtopping and lagoon opening. More evenly distributed rainfall patterns also lead to a more constant input of freshwater, increasing homogeneity of lagoon water conditions throughout the year and stabilizing salinity fluctuations. This in turn affects lagoon ecosystems including fish stocks (Diop and Sherin 2016).

Lagoon and shallow marine ecosystems are also affected by changing water temperatures. A general warming of coastal waters has been noted for the Gulf of Guinea (Druyan 2011). Although there is limited data on the impact of this warming on fisheries in the region, marine species in equatorial regions in general have seen a decline, as they are unable to respond to rapidly increased water temperatures (Hastings et al. 2020). Deoxygenation and acidification of ocean waters are also a consequence of climate change, and both are expected to indirectly reduce maximum fish catch. How fishing communities deal with the physical and ecological changes related to climate change is dependent on their vulnerability to those changes and their ability to adapt to them. Vulnerability and adaptation are inextricably linked, and any discussion about climate change adaptations warrants an overview of the architecture of the vulnerability of lagoon fishing communities.

---

## **Vulnerability of and Adaptation to Climate Change in Lagoon Fishing Communities**

Vulnerability can be defined in several different ways in line with different epistemological orientations. However, whether grounded in physical science and human or political ecology, the key concept in vulnerability is the potential for loss or susceptibility to harm. The vulnerability of a community to climate change can be considered as its susceptibility to all the collective changes it experiences. The vulnerability of lagoon fishing communities is related to several multi-scalar factors or causes. The causes of vulnerability in lagoon fishing communities might be categorized into four sources: international, intrinsic, internal, and institutional. International sources refer to global climate and physical environmental change processes such as sea level rise, increase in sea surface temperature, and others, as outlined in the preceding sections. These processes, *inter alia*, reduce fish catches and revenue (Lam et al. 2016; Dey et al. 2016). Reduced incomes, in neoclassical economic terms, imply reduced purchasing power and so low material well-being (i. e., possession of natural, physical, financial, human resources). Intrinsic sources of vulnerability are those unique to coastal fishing communities and directly linked to their fishing activities. These factors are diverse and include the hazards encountered during fishing (e.g., storms), the seasonality of fish catches, as well as the high unpredictability of making catches. It also includes their high susceptibility to macroeconomic changes. For example, they are forced to accept the market cost of fuel and other necessary resources.



While intrinsic sources refer to features, which are uniquely associated with the small-scale fishing livelihood itself, internal sources refer to features commonly associated with coastal fishing communities. These include overfishing, gender and income inequality, intra-community conflicts, lack of cooperation, mistrust, and limited livelihood diversification opportunities (Béné 2006). Because artisanal fishing is mostly done in crews and lagoon fishing communities are usually small, trust, camaraderie, and solidarity are essential to sustaining the fishing activity and the community. When these sociocultural factors are missing, the very survival of the fishing livelihood is threatened. Moreover, these internal factors create differentiated experiences of vulnerability within fishing communities (Zacarias 2019; Koomson et al. 2020). Lastly, institutional sources are those related to rural planning, infra-structural development, and encroachment of industrial trawlers. Fishing communities do not usually participate in fisheries planning and management decision-making, have little social amenities, and often must deal with encroachment of large trawlers in local fishing waters. This list of vulnerability sources is by no means exhaustive. It is only a sample of the common features of artisanal lagoon fishing communities, which interact in complex ways with the impacts of climate change to make them susceptible to socioeconomic losses.

Whereas vulnerability refers to the susceptibility to harm, adaptation is the process of adjusting to the actual or expected harm and associated impacts, in order to either moderate the harm or exploit beneficial opportunities. The term adaptive capacity is used when considering how capable an individual or community is of adapting to harm or change. The adaptive capacity is based on an individual or a community's available resources that can be drawn on to achieve adaptation. The specific ways in which those combinations of available resources are enacted to moderate harm or exploit beneficial opportunities are then referred to as adaptive strategies. When considering and assessing adaptations and adaptive capacity, there are several critical concepts that should be accounted for. Firstly, it is rooted in the definition of adaptation. An adaptation is an adjustment to moderate actual or potential impacts, not to eliminate or "overcome" them. Secondly, the definition itself makes no value judgment about the legality of the adjustment process or on how the moderation of actual or potential impacts is achieved. In normative terms therefore, any action that has some moderating effect on impacts would qualify as an adaptation strategy. Thirdly, from the definition, adjustments to moderate impacts or benefits from opportunities would not be limited to actions only but also prohibitions. Communities themselves may spontaneously enact adaptations and adaptive strategies. These are referred to as autonomous adaptations.

---

## **Community-Level Autonomous Adaptations**

Autonomous adaptations enacted to reduce or moderate harm in SSF communities might also be considered in the context of reducing risk to those communities. Risk reduction strategies that are spontaneously developed by communities whose livelihoods depend on natural resources, such as SSF communities, can be divided into

five categories: over time (*storage*), across space and time (*mobility*), across asset classes (*diversification*), across households (*communal pooling*), and *market exchange* (Agrawal 2008). Communities and individual households may choose to combine and enact any of these strategies to achieve their desired outcomes. This is central to the concept of sustainable rural livelihoods and is important to examine when considering adaptations and adaptive capacity.

One of the earliest discussions on sustainable livelihoods (Chambers and Conway 1992) provided a similar list, which also included reduction of current consumption (*stinting*), preservation and protection of the asset base for recovery (*protection*), and making claims on relatives or NGOs (*claiming*). In a similar discussion on sustainable livelihoods, Scoones (1998) describes two more livelihood strategies: increasing input per unit area (*intensification*) and expanding the area under production (*extensification*). These livelihood/adaptation strategy typologies were developed predominately from the study of rural agrarian communities. However, they are also useful for characterizing adaptation strategies reported for commonly reported stressors experienced by fishing communities worldwide, not just in West Africa. These stressors are noted in Table 1. Not all stressors listed are directly related to climate change. Physical stressors like storms and floods and decreasing fish catches are a consequence of climate change. However, encroachment of industrial trawlers into artisanal fishing zone causing competition is not. Competition from trawlers is noted here because of the large impact it has on SSF communities and their vulnerability to climate change. An “experimentation” grouping in the table captures adaptation practices that are less well-established and in an initial learning phase of development (Table 1).

The most common adaptation strategies adopted by SSF communities are intensification strategies (Béné 2006). When fish catches are low, the first and immediate response of SSF communities is to put in more effort either by going further out at sea, spending longer hours at sea, changing fishing gear (equipment) to target fish species that may be relatively more abundant, or increasing the frequency of fishing activities. For example, in a coastal lagoon fishing community situated on the Muni Lagoon in Ghana, the major fishing season, which traditionally lasted from August to April, has been extended by some fishing crews by starting their fishing activities from July to May of the following year. This is largely in response to an erratic rainfall pattern in the major rainy season in southern Ghana. For supplemental incomes, lagoon communities may increase fishing in lagoons and use gears or methods considered illegal. In Benin, *Acadjas* (a purely ingenious practice of creating a favorable microclimate within a lagoon with sticks and leaves for recruitment of big fish) and *médokpokonou* (another traditional method which uses nets with fine and tight stitches) are both prohibited, but they are commonly practiced. This is because the former reduces overall fish species richness, and the latter removes small and juvenile fishes (Dossou and Glehouenou-Dossou 2007; Niyonkuru and Lalèyè 2010). The use of mosquito nets in fishing communities has also been observed in Cote d’Ivoire, Ghana, and several other sub-Saharan African countries (Short et al. 2018). This diverts the use of nets away from their role in protecting coastal communities from mosquitoes and negates efforts to reduce

**Table 1** Examples of autonomous adaptation to key stressors of small-scale fishing livelihood in West Africa

Stressor	Examples of adaptations
<i>Physical (e.g., storms, floods and SLR)<sup>a</sup></i>	Use of sandbags and rubbish to form defense walls Change of building materials (from wood and thatch to cement blocks and galvanized roofing sheets) Landward relocation of buildings
<i>Reduced fish catch<sup>d–g</sup></i>	<i>Intensification strategies</i> Spending longer times at sea Use of small meshed nets (e.g., <i>médokpokonou</i> and “wan” practices in Benin) Fish trapping (e.g., the <i>Acadja</i> practice in Benin) Change of gear and fish species harvested Increased frequency of fishing in lagoons Extended major fishing season <i>Extensification strategies</i> Going further out into the sea Fishing in neighboring coastal communities during taboo days in own community (practiced in some beach-seining communities in Ghana) Temporal migration <i>Diversification/occupational mobility strategies</i> Taking wage labor jobs during lean seasons Adding supplementary livelihoods like livestock rearing Sand winning (extraction) Planting, harvesting, and sale of coconut fruits <i>Storage strategies</i> Preservation of fish for sale in lean seasons and/or to sell in new and fairer markets Reducing household expenditure in order to save money Borrowing from money lenders Remittances <i>Experimentation strategy</i> Varying the hours within the day when fishing expeditions are made
<i>Encroachment of industrial trawlers into artisanal fishing zone</i>	<i>Experimentation strategy</i> Studying to precede trawlers or waiting a long while after they have gone

<sup>a</sup>Freduah et al. (2018)<sup>b</sup>Béné (2006)<sup>c</sup>Perry and Sumaila (2007)<sup>d</sup>Dossou and Glehouenou-Dossou (2007)<sup>e</sup>Niyonkuru and Lalèyè (2010)<sup>f</sup>Daudu et al. (2020)<sup>g</sup>Adelekan and Fregene (2015)

malaria. Intensified fishing efforts in response to declining catches are the main reasons behind accusations of SSF as being overexploitative and unsustainable.

Adaption studies from Ghana show that SSF communities also extend efforts by going further into the sea, fishing in areas outside those of their own fishing

communities, or moving temporarily to other towns or even countries to fish (Perry and Sumaila 2007; Freduah et al. 2018). Some small-scale fishers maintain contact with fishers from other communities through mobile phone communication to share information about the location of big catches. The fishers respond quickly by moving to that location to fish for a day or two. It is common among West African coastal fishing communities to have indigenously instituted no-fishing (taboo) days (Adjei and Sika-Bright 2019). By way of extensification, some fishing crews move from their communities on taboo days to fish in nearby communities as a strategy to increase catch and thus their weekly earnings. These strategies thrive on good social networks and camaraderie between communities.

Adaptations that are based on diversification of livelihood in SSF communities involve either taking on additional sources of income or changing and acquiring different types of fishing gears or both. Daudu et al. (2020) have shown that gear and occupational diversification are priority strategies for some fishing communities in Nigeria. Some members of a fishing household may take up wage labor jobs as complementary livelihood sources all year round or during some parts of the year. However, for households that have temporary non-fishing livelihoods, fishing is an activity to which they always return. Few artisanal fishers ever leave fishing permanently. Fishing, for them, is not just a livelihood activity; it is their culture, an important part of their identity and something they take pride in. West African coastal fishing communities do not have a strong tradition of farming as an additional source of income. However, recent increase in demand of specific products has provided opportunities for the diversification of livelihoods into harvesting local products. For example, in Ghana, the rise of demand for coconut fruits in large cities has created opportunity for fishers living in coastal areas to harvest and sell coconuts from coconut trees in their vicinity. Others harvest from trees growing on “no man’s lands.” This has become an important complementary source of income for fishing communities. In some instances, community members might engage in illegal activities to diversify sources of income. Sand winning (extraction of sand from beach areas) is a prohibited activity in most communities and illegal in accordance with national policy in most West African countries. However, some members of SSF communities are involved with sand winning for income.

Evolution of storage strategies is commonly reported as an autonomous adaptation in lagoon communities along coastal West Africa. Storage strategies have been identified in fishing communities in Cote d’Ivoire (Njifonjou et al. 2006), Ghana (Freduah et al. 2018), and Nigeria (Adelekan and Fregene 2015). Storage strategies are usually in the form of securing household sustenance by processing (commonly by smoking or drying) and storing fish to be sold in the lean fishing seasons, borrowing from credit lenders, and/or saving money during the major fishing seasons. This money-saving strategy differs from conventional money-saving practices that aim at saving disposable income. It is an active and often necessary saving against lean seasons, unexpected periods like stormy conditions, or close fishing seasons. It has also been widely observed that some rural households are cushioned by remittances from household members who have migrated either temporarily or permanently from their original community. While this may be true for some

communities, it may be a largely missing income stream in other communities. For example, Atti-Mama (1998) reported in a study of nine communities around Lake Nokoue in Benin that more than 95% of households did not receive any remittances.

In response to the encroachment of large trawlers into local fishing waters, coastal fishing communities have no clear strategy. As this is a longstanding but still evolving problem, identified adaptive strategies are, at best, experimental. This may be more conveniently termed a coping mechanism rather than an adaptive strategy. Some authors have particularly highlighted that adaptation strategies are different from coping strategies noting that the former are permanent and long-term changes in practices, while the latter are temporary and short-term changes in livelihood practices (Scoones 1998).

The Muni Lagoon and Akosua Lagoon community are used as a case study to illustrate the importance of understanding the vulnerability of an SSF community when planning adaptations.

---

## **Understanding Vulnerability for Effective Adaptation Planning: Muni Lagoon Case Study**

Internal factors can differentiate the experience of vulnerability in fishing communities. This phenomenon presents both challenges and opportunities for effective adaptation planning in fishing communities. A case study of Akosua village, a lagoon fishing community in Winneba, Ghana, demonstrates this (Koomson et al. 2020).

Akosua village is a small migrant fishing community located on the central coast of Ghana on the outskirts of the town of Winneba (Fig. 1). The community is situated on the sandy barrier that separates the Muni Lagoon from the Atlantic Ocean. The lagoon has been well studied as it was designated as a Ramsar (protected wetland) site in 1992 (GEF 1992). The economy of the community is based predominately on beach seining. This is a fishing method that involves the deployment of seine nets into the sea and hauling them back to shore by hand. Beach seining is done mainly by men. The women in the community are the fishmongers, mostly engaged in the processing and selling of fish. In addition to the predominantly fishing-based livelihood, some women engage in petty trading, and some men engage in daily wage labor jobs within the town of Winneba. Farming and livestock rearing are uncommon in the community due to the sandy and saline nature of the land. The poor quality of the land for farming is common to all lagoon communities and limits opportunities for alternative livelihoods. To understand how vulnerability is manifested within the community, the structure of the fishing activity must be appreciated. Fishing crews are typically made up of the “net owner” (i.e., the owner of the boat, outboard motor, and seine net), boat crew (the net owner’s permanent employees), and net draggers (casual workers who haul the net to shore). This crew hierarchy delineates households’ economic class as profit is typically shared in the ratio 4:2:1 among the net owner, boat crew, and net draggers, respectively. Crews range from about 12 to 35 men depending on the size of boat and net. The major fishing season starts from the end of the major rainy season (July/

August) to its beginning (March/April) the following year. The period in between (April–July) is the major rainy season characterized by stormy conditions. Thus, no or very limited fishing activities take place during that part of the year. The community major fishing seasons are considered the “good season” when catches are big and incomes are high and the “bad season” when catches are small and incomes are low. This is purely subjective but reflects the community’s perception of their well-being during the year. Besides the interruption of fishing activities and income flows by unpredictable stormy conditions, sudden rainfall is a major problem to fish processing. The major fish processing method used in the community is drying in the open fields (Fig. 2). Unexpected rainfall, therefore, results in losses as the half-dried fish in the open fields deteriorate upon contact with water. Besides this, long periods of dryness cause the surface area of the lagoon to decrease in size and reduce the lagoon’s water quality. Changes to the lagoon size and water quality have knock-on detrimental effects on fish productivity and species diversity.

The study integrated the concepts of vulnerability and the capital assets component of the sustainable livelihoods approach (SLA) to understand how the lives and livelihood of the community are impacted by climate variability. Drawing upon the IPCC’s definition of vulnerability as a function of the magnitude of climate variation to which a system is exposed (E), its sensitivity (S), and its adaptive capacity (AC), a simple equation that multiplies E, S, and AC was used to quantitatively estimate the vulnerability of each household. This is a commonly used methodology according to the Intergovernmental Panel on Climate Change (IPCC 2014). The SLA is a framework designed to identify combinations of livelihood resources, which give people the ability to adopt livelihood strategies that produce their desired outcomes, as well as the institutional processes that mediate their ability to carry out such livelihood strategies within defined policy and ecological and socioeconomic



**Fig. 2** Drying fish on a dry lagoon bed in Winneba, Ghana. (Photo D. Koomson)

contexts (Scoones 1998). At the heart of the SLA is the concept that rural communities draw upon and combine five main capital assets (natural, physical, social, human, and financial) to build their livelihoods and respond to shocks. An assessment of the levels of these capital assets and barriers to their access gives insight into what policies are necessary to expand the livelihood platform, thereby improving adaptive capacity and reducing vulnerability (Freduah et al. 2018).

Understanding the experience of vulnerability and autonomous adaptations to climate change in the Akosua community, and the role that internal factors play, has implications for adaptation planning in the community and other communities with similar contexts along the West African coastline. The scale of economic impact that bad seasons have on the household incomes is very important in determining vulnerability. Comparing incomes in good and bad seasons shows that household income drops by about 90% in a bad season (Koomson et al. 2020). With good seasons becoming rare with increasing climate change, food security is threatened. Vulnerability to impacts is not felt in the same way across the community. It is differentiated depending on the gender and wealth status of a household head. For example, in bad seasons, a household in a lower wealth rank and headed by a woman may be comparably less vulnerable than a household of a higher wealth rank and headed by a man. Thus, the most vulnerable are not necessarily female-led and poorer households, as might be expected. Adaptation planning, such as the introduction of alternative/complementary livelihoods, therefore, must be flexible enough to respond to the cyclical and yet unpredictable nature of bad seasons and prioritize the most vulnerable. Such an intersectional understanding of vulnerability is essential for effective adaptation planning because the factors that are responsible for determining who is more vulnerable in the community differ depending on how households are categorized for study (Koomson et al. 2020). An intersectional understanding means that each household's experience of impact should be understood based on the different social identities that characterize that household. For example, a poor household, headed by a woman who is a migrant, may experience impacts differently from a poor household, headed by a woman who is indigenous to that place. Achieving optimum success in adaptation implementation would require that important nuances in differential vulnerability, as identified through an intersectional lens, be leveraged to prioritize critically vulnerable households. This detailed understanding of vulnerability in SSF communities is key to informing interventions that support successful adaptations to climate change. The development, implementation, and inaction of adaptation intervention strategies to address climate change in SSF communities can be realized on the large scale by embedding concepts of adaptation and adaptive capacity in regional and national coastal governance and policy.

---

## **Policy Implementation and Participatory Governance**

Along with the community-level adaptation, there are policy and governance structures that aim to implement sustainable adaptive capacities for SSF communities. Coastal policies create strategies and establish governance processes and

mechanisms to enable coastal fishing communities to implement adaptations to protect and deal with climate change. Well-informed and wide-ranging coastal policies acknowledge that subsistence and resource-dependent SSF communities are faced with climate change impacts and need to undertake sustainable practices for their livelihood, well-being, and development. There are a number of overarching international frameworks that influence and guide regional and national coastal governance and policy in West Africa. These directly or indirectly inform strategies for and governance of adaptation to climate change in lagoon communities.

## **International Policies and Frameworks Influencing Coastal Governance and Policy**

At the global level, the Intergovernmental Panel on Climate Change (IPCC), Sustainable Development Goals (SDGs), and Ramsar Convention provide overarching frameworks for considering coastal governance. In addition, the concept of integrated coastal zone management establishes guidance on managing coastlines holistically. The IPCC highlights the need to explicitly address coastal communities in any climate change policy. The SDGs, specifically 1, 6, 7, 12, 14, and 15, draw attention to the threats posed by climate change in coastal communities in countries of the Global South (UN 2015). Sustainable Development Goal 14, “Conserve and sustainably use the oceans, seas and marine resources for sustainable development,” is particularly pertinent for the resources, economy, and livelihood of these coastal communities (UN 2015). This is manifested through the vision of the “Blue Economy”: the sustainable use of ocean resources for economic growth, improved livelihoods and jobs, and ocean ecosystem health (World Bank 2015). The concept of integrated coastal zone management (ICZM) arose from the Earth Summit (Rio Convention) in 1992. The aim of the ICZM was to enable governments to create national agendas to understand and find solutions to managing the complex and dynamic nature of the coastal environment. The ICZM concept is embedded in the ecosystem approach, a strategy for the integrated management of land, water, and living resources that promotes conservation and sustainable use in an equitable way. Both the ICZM and the ecosystem approach require that management of the coastline incorporates the impact on and implications for coastal communities of resource usage, pollution, livelihoods, and hazards (including climate change). The aim was to merge physical and environmental aspects of coastal management with human needs, with the ultimate benefit of maintaining coastal ecosystems and environments. However, embedding both the ICZM and the ecosystem approach in decision-making and implementation in the Global South, including West Africa, has not proved to be successful, and considerable challenges remain. The International Convention on Wetlands of 1971, otherwise known as the Ramsar Convention, was established as an international cooperation with national action for the conservation and wise use of resources in wetlands (both coastal and inland) of global significance, including coastal lagoons. Of the countries discussed here, Ghana became a member state of the Ramsar Convention in 1988, closely followed by



Togo (1995) and Cote d'Ivoire (1996). Benin and Nigeria became contracting parties in 2000 and 2001, respectively. The ways in which the Convention mandates are implemented by respective governments differ vastly as the Ramsar Convention gives national governments a broad scope for implementation that relies on effective, dynamic and multilevel processes of implementation (Mauerhofer et al. 2015). The Convention does provide a platform for knowledge transfer as well as management oversight and some level of resources for the protection of specific coastal lagoons.

Along with these international conventions, frameworks, and treaties, there have been regional collaborative initiatives relevant to coastal fishing communities. These regional partnerships include measures to sustainably manage marine and coastal resources, including fish stock and coastal habitats, which help augment the resilience of coastal communities to climate change (FAO 2018).

## Regional Frameworks and Governance

At the regional level, West African countries have undertaken different collaborative initiatives and frameworks related to aspects of coastal management and governance. These include the West Africa Coastal Areas Resilience Investment Project (WACA ResIP), the Guinea Current Large Marine Ecosystem (GCLME) program (GCLME 2006), the Fisheries Committee for the West Central Gulf of Guinea (FCWC), and the West Africa Coastal Areas (WACA) Management Program.

The West African countries of Benin, Cote d'Ivoire, Togo, and Senegal are part of a six-country West Africa Coastal Areas Resilience Investment Project (WACA ResIP) aimed at strengthening coastal communities in West Africa. This program assesses coastal damages in terms of economic impacts, environmental implications, and social effects of changing climate. Since 2005, the joint United Nations Development Programme-Global Environment Facility-United Nations Industrial Development Organization (UNDP-GEF-UNIDO) regional collaboration known as the Guinea Current Large Marine Ecosystem (GCLME) program has existed to reduce poverty and enhance economic development of coastal communities through the provision of country-driven mechanisms to support marine and coastal goods and services. It comprises 16 countries of West Africa, including Cote d'Ivoire, Ghana, Benin, Togo, and Nigeria. The GCLME has its roots in the late 1990s when the ecosystem approach was introduced to assess and manage marine resources in West Africa. It provided a framework to promote the ecosystems approach and broaden the scope of coastal management in the region. It prioritized five aspects of coastal communities and environments: (i) productivity, (ii) fish and fisheries, (iii) pollution and ecosystem health, (iv) socioeconomic conditions, and (v) governance. The GCLME enabled large investments to combat coastal change and implement management strategies for coastal issues in the region. An emphasis was placed on monitoring physical processes and hard engineering solutions with little recognition of lived experience of coastal communities. Coupled with weak assessment and governance and an inadequate understanding of the complexities facing coastal communities, the programs put in place through the GCLME have not been successful.

The FCWC and WACA have focused on small-scale fishing. Goals of these programs have been to promote sustainable fisheries management, build strong fisher folk associations, support women in fisheries, ensure efficient fisheries value chains, and identify the challenges of overfishing and other competing uses for coastal areas. The Fisheries Committee for the West Central Gulf of Guinea (FCWC) is a regional integration plan for the Food and Agriculture Organization to ensure the “the blue economy” of the region is based on the participation of small-scale fishers in resource management. It was created by the nations of Benin, Ghana, Togo, Nigeria, Liberia, and Cote d’Ivoire to boost the fisheries sector, by ensuring the sustainable management of their fisheries resources for export and small-scale fishing communities. The West Africa Coastal Areas (WACA) Management Program was launched in 2018 by the World Bank. At its center, the WACA provided access to knowledge and technical expertise, made political and financial commitments, and supported a coordinated, regional approach for coastal resilience in West Africa to enhance adaptive capacity of fishing communities. While these multiple regional and international efforts have been well-intentioned, they suffer from some major drawbacks. Multiple initiatives have led to overlapping governance efforts, with complex organizational structures, funding, and implementation processes that have hampered the success of the initiatives. A top-down approach with limited local input and ownership of projects also meant that the long-term success of initiatives was restricted (Wiafe et al. 2013). All of these initiatives and frameworks emphasized management of the coastline and near-shore environments rather than focusing on climate change. The National Adaptation Programme of Action (NAPA) plans do specifically address adaptations to climate change in countries of the Global South and inform climate change policy relevant to coastal environments and communities.

## **National-Level Coastal and Climate Change Policy Mechanisms**

The National Adaptation Programme of Action (NAPA) is national-level adaptation plan submitted to the United Nations Framework Convention on Climate Change (UNFCCC) secretariat by the least developed member states in 2007 and 2008. These documents outline the threat to individual nations and their planned priority adaptation actions. Development of the Intended Nationally Determined Contributions (INDC) followed, submitted in 2015. The INDC outline the priority adaptation sectors and interventions for a country and run from 2016 to 2030. The National Adaptation Programme of Action (NAPA) for coastal West African countries acknowledged the adverse impacts of climate change on SSF communities, signposting threats to these communities and their livelihoods and creating adaptation plans (Table 2).

The selection of priority adaptation interventions for NAPAs (and INDCs) was based on a multi-criteria analysis that included monetary cost and benefit, potential economic benefits and synergy with other environmental policies, as well as potential contribution to poverty alleviation. While it is noteworthy that SSF communities and their livelihood are quite significantly acknowledged in national policies, none

**Table 2** Climate change adaptation plans for coastal SSF communities across West Africa

Country	Stated adaptation plans for SSF communities
Ghana <sup>a,b</sup>	Enhance fisheries resource management Develop alternative sources of livelihoods for fisher folk Promote fish farming
Nigeria <sup>c,d</sup>	Enhance artisanal fisheries and encourage sustainable aquaculture Encourage the provision of social welfare programs by faith-based and civil society organizations to address the climate change-induced needs of vulnerable groups
Togo <sup>e</sup>	Protect the coastal zone Strengthen infrastructure resistance to climate change in coastal zones Strengthen community resilience to climate change in the coastal zone
Benin <sup>f</sup>	Ensure the protection of the shoreline against the risk of sea level rise Reduce the vulnerability of human settlements and resources located in the coastal area to sea level rise Ensure continuously the protection of marine and lagoon ecosystems
Cote d'Ivoire	All policy documents for this country are in French (official language of the country) thus not accessible for review purposes

<sup>a</sup>Ghana's INDC (2015)<sup>b</sup>National Climate Change Adaptation Strategy (2010–2020)<sup>c</sup>Nigeria's INDC (2015)<sup>d</sup>National Adaptation Strategy and Plan of Action on Climate Change for Nigeria (NASPA-CCN, 2011)<sup>e</sup>Togo's INDC (2015)<sup>f</sup>Readiness Project for Benin's Intended Nationally Determined Contributions (2018)

of these actions made it into the priority actions for any of the countries, which were mostly focused on agriculture, transportation, energy, and health sectors. The MCA approach is likely responsible for the prioritization of other livelihoods like rural agriculture over SSF fishing. As is widely noted in the SSF literature, the contribution of SSF to national economies, in terms of GDP, is relatively small. Poverty alleviation, food security, and rural economic development are the most significant contributions of SSF. However, it is also acknowledged that in comparison to other rural livelihood activities like farming, SSF has higher exposure and sensitivity to climate change impacts. While the MCA process is not completely described in the reviewed documents, it could be conjectured that if the disproportionately higher vulnerability of SSF communities had been considered and higher weights assigned to poverty alleviation and food security, adaptation interventions for SSF communities would have risen in priority. Countries differed in which aspects of coastal adaptations took precedent (Table 2). While some countries (Ghana and Nigeria) focused on livelihoods of coastal communities by establishing means for improving and enhancing income generations, others such as Benin, Togo, and Cote d'Ivoire concentrated more on hard engineering solutions to protect coastal infrastructure (Table 2). The NAPA were not as wide-ranging or successful as they might have been at addressing coastal adaptations to climate change.

All countries adopted a multi-sectoral approach to adaptation planning and demonstrate an appreciation of the need to connect adaptation planning with the broader national development agenda. However, the multifaceted and complex

interlinkages between climate change, natural resources, and local development issues that underpin vulnerability of a community, and which are critical to successful adaptation interventions, were not fully appraised as part of the plans. In addition, NAPA implementation required strong cross-sectoral collaboration to realize the planned adaptation interventions, and this was not necessarily in place due to gaps between national policy and local implementation.

---

## **Adaptation to Climate Change in Coastal Communities: The Policy Gap**

Institutional arrangements in Africa have conventionally followed a formal, top-down framework. The national and regional policy agreements in Benin, Nigeria, Ghana, Togo, and Cote d'Ivoire aimed at coastal management and enhancing adaptive capacity of coastal communities are managed and implemented by government organizations, often in partnership with nongovernmental organizations. This multi-organizational, top-down approach has resulted in several barriers to the successful implementation of policy-driven climate change adaptation strategies at the coast. Policy deployment through multiple national and nongovernmental agencies can often result in uncoordinated and overlapping strategies resulting in confused implementation at the local level and limited success of adaptation strategies. The current national governance top-down approach allows limited opportunities for local governance. This creates a gap, "the policy gap," between the well-intentioned policy discourse at the national government level and the actual implementation of policy at the village level. The top-down approach also results in failure to understand and address the highly localized and often community-specific conditions required to enact successful climate change adaptations. When multi-institutional governance structures include engagement opportunities for local communities, the success of coastal management plans and adaptation strategies is greatly enhanced. For example, an understanding of specific local environmental conditions and socioeconomic responses is needed when developing adaptations to sea level rise, but national policies currently do not support that local oversight (Hauer et al. 2020). In addition to the difficulties created by pursuing a top-down approach, the policies themselves have tended to have a disproportionate focus on physical and resource management of the coastline rather than adaptations that address the social and human impacts of climate change (Clarke et al. 2013; Butler et al. 2015; Cinner and Barnes 2019). The physical effects of climate change have been prioritized over livelihood, well-being, and cultural needs of communities. Such an approach requires reconciling lagoon conservation issues with the livelihood interests and local economy of lagoon communities. In Ghana, an example of the disconnect between national coastal resource policy and local community needs is seen in the mismanagement of mangroves. Mangroves are overexploited by lagoon communities, despite playing a vital role in the physical protection of coastal areas, and mangrove conservation plans at lagoons have suffered from a lack of administrative coordination across ministries and agencies (Boateng 2018). Conventional multi-

institutional, top-down systems of government have not been very successful in resolving or managing coastal problems (Clarke et al. 2013). The need to shift to a human-centered, bottom-up approach to managing lagoon environments and their communities, where communities are participants to the planning, co-production, and implementation of coastal adaptations to climate change, is key to their long-term resilience and sustainability (Butler et al. 2015).

---

## Participatory Governance

The recognition of the gap between national policy discourse and local implementation has prompted a shift to the development of a more participatory approach that ensures coastal communities are central to the joint management of their resources and local environment. In this participatory approach, community knowledge is used to bridge the gap between national policy, climate research, and lived experience of climate change (Clarke et al. 2013). The resultant integrated governance systems to support climate change planning and adaptations combine local participatory governance with multi-institutional government and nongovernmental organizations. This bottom-up approach ensures that community needs are addressed and local conditions are taken into account in adaptations to climate change and the management strategies that support them. In effect, a balance between “top-down” policy implementation and “bottom-up” community-driven needs that maps the top-down agenda to a community-based approach is recommended for successful adaptive strategies (Butler et al. 2015). In this approach, there is a recognition of the contextual factors through local stakeholder engagement as well as the integration of indigenous knowledge and local approaches to understand, manage, and create solutions for climate change adaptations (Cinner and Barnes 2019). Indigenous knowledge and traditional practices have developed over generations by communities coping with climatic variability and extreme weather (FAO 2018), such as in Nigeria, where SSF communities use their traditional knowledge of local meteorological variation to inform adaptations to the management of coastal flooding.

Most of the research about participatory governance of coastlines in West Africa focuses on Ghana and Nigeria with fewer studies from Benin, Togo, and Cote d’Ivoire. Ghana has many agencies with a top-down institutional framework, including those that govern the coastal and marine environment. However, progress is being made toward creating participatory structures for coastal management and climate change adaptation, specifically around the areas of resource management, environmental monitoring, and community education (Wiafe et al. 2013). The participatory approach is also being used in fishing communities along the Badagry coast of Nigeria to create and implement local adaptations to climate and environmental change (Olawepo 2008). Another example is from the Aby Lagoon in Côte d’Ivoire, where co-management of fishing resources has given fishing communities a sense of engagement, ownership, and empowerment that has supported sustainable livelihoods, enhancing resilience to climate change (Njifonjou et al. 2006). The

success of these participatory approaches is encouraging for future implementation of climate change adaptations in coastal lagoon communities across West Africa.

---

## Summary

The coastlines of Cote d'Ivoire, Ghana, Benin, Togo, and Nigeria are dominated by dynamic lagoon environments. Sea level rise and climatic changes are affecting those lagoons and their associated nearshore environments. The fishing communities that live next to lagoons depend on them for resources and ecosystem services that support economic livelihood and well-being. The vulnerability of lagoon communities to climate change is related not only to the physical and environmental effects of climate change but also to local resource use, sociocultural community structures, susceptibility to external factors, population growth, and governance infrastructures. The interconnected nature of climate-related challenges with development issues complicates the success of climate change adaptations and interventions. Adaptations enacted as part of a managed intervention plan require an understanding that vulnerability to climate change is not felt in the same way in different communities nor even across a single community and an acknowledgment of intersectionality is required when deciding how and where to place adaptation interventions.

Multiple frameworks exist in West Africa that are related to the management of the coastal zone, and National Adaptation Programme of Action (NAPA) plans in the region have included coastal communities. National coastal policy arising from such frameworks should be the vehicle for managing climate change adaptations in lagoon communities. However, where such policy exists, it has suffered from formal top-down approaches with gaps between policy and its implementation as well as uncoordinated approaches. Importantly, the policies themselves have failed to acknowledge the human experience of climate change, tending to focus on physical change at the coast. To rectify this, climate and coastal change policy must evolve to embed concepts of adaptation and adaptive capacity, giving the same consideration to community livelihood and well-being as to the physical environment. An integrated participatory approach, which allows lagoon communities to play a key role in the governance of the coastal zone, will enable such a human-centric approach and facilitate the integration of climate change adaptation into coastal planning and management.

---

## References

- Adelekan IO (2010) Vulnerability of poor urban coastal communities to flooding in Lagos, Nigeria. *Environ Urban* 22(2):433–450. <https://doi.org/10.1177/0956247810380141>
- Adeniyi MO (2016) The consequences of the IPCC AR5 RCPs 4.5 and 8.5 climate change scenarios on precipitation in West Africa. *Clim Chang* 139:245–263. <https://doi.org/10.1007/s10584-016-1774-2>
- Adelekan I, Fregene T (2015) Vulnerability of artisanal fishing communities to flood risks in coastal southwest Nigeria. *Clim Dev* 7(4):322–338. <https://doi.org/10.1080/17565529.2014.951011>

- Adjei JK, Sika-Bright S (2019) Traditional beliefs and sea fishing in selected coastal communities in the Western Region of Ghana. *Ghana J Geogr* 11(1):1–19. <https://doi.org/10.4314/gjg.v11i1.1>
- Agrawal A (2008) The role of local institutions in adaptation to climate change. World Bank. <https://doi.org/10.1596/28274>
- Akanni KA (2010) Fishing technologies and catch levels among small-scale fishers in Lagos state, Nigeria. *N Am J Fish Manag* 30:309–315. <https://doi.org/10.1577/M08-061.1>
- Anthony EJ, Oyede LM, Lang J (2002) Sedimentation in a fluvially infilling, barrier-bound estuary on a wave-dominated, microtidal coast: the Ouémé River estuary, Benin, west Africa. *Sedimentology* 2002 49(5):1095–1112. <https://doi.org/10.1046/j.1365-3091.2002.00491.x>
- Appeaning-Addo K (2014) Managing shoreline change under increasing sea-level rise in Ghana. *Coast Manag* 42:555–567. <https://doi.org/10.1080/08920753.964820>
- Atti-Mama C (1998) Co-management in continental fishing in Benin: the case of lake Nokoué. In *The International Workshop on Fisheries Co-Management*. (NO DOI)
- Awoskia LF, Ibe AC (1993) Geomorphology and tourism related aspects of the Lekki barrier-lagoon coastline in Nigeria. In: Wong PP (ed) *Tourism vs environment: the case for coastal areas*. The geo-journal library v. 26. Springer, Dordrecht. [https://doi.org/10.1007/978-94-011-2068-5\\_9](https://doi.org/10.1007/978-94-011-2068-5_9)
- Béné C (2006) Small-scale fisheries: assessing their contribution to rural livelihoods in developing countries. *FAO Fish Circ* 1008:46. (NO DOI)
- Bernacsek GM, Hughes JS, Hughes RH (1990) A directory of African wetlands. (NO DOI)
- Blankespoor B, Dasgupta S, Laplant B (2014) Sea level rise and coastal wetlands, *Ambio*. The Royal Swedish Academy of Sciences. <https://doi.org/10.1007/s13280-014-0500-4>
- Boateng I (2012) An application of GIS and coastal geomorphology for large scale assessment of coastal erosion and management: a case study of Ghana. *Journal of coastal conservation* 16 (3):383–397. <https://doi.org/10.1007/s11852-012-0209-0>
- Boateng I (2018) An assessment of vulnerability and adaptation of coastal mangroves of West Africa in the face of climate change. In: Makowski C, Finki CW (eds) *Threats to mangrove forests*, coastal research library 25. [https://doi.org/10.1007/978-3-319-73016.5\\_7](https://doi.org/10.1007/978-3-319-73016.5_7)
- Brown S, Kebede AS, Nicholls RJ (2011) Sea level rise and impacts in Africa 2000–2010. <http://www.unep.org/climatechange/adaptation/Portals/133/documents>. (NO DOI)
- Butler JRA, Wise RM, Skewes TD, Bohensky EL, Peterson N, Suadnya W, Yanuartati Y, Handayani T, Habibi P, Puspadi K, Bou N, Vaghelo D, Rochester W (2015) Integrating top-down and bottom-up adaptation planning to build adaptive capacity: a structured learning approach. *Coast Manag* 43:346–364. <https://doi.org/10.1080/08920753.2015.1046802>
- Cinner JE, Barnes ML (2019) Social dimensions of resilience in social-ecological systems. *One Earth* 1:51–56. <https://doi.org/10.1016/j.oneear.2019.08.003>
- Chambers R, Conway G (1992) Sustainable rural livelihoods: practical concepts for the 21st century. Institute of Development Studies (UK). <https://opendocs.ids.ac.uk/opendocs/handle/20.500.12413/775>
- Clarke B, Stocker L, Coffey B, Leith P, Harvey N, Baldwin C, Baxter T, Bruekers G, Galano CD, Good M, Haward M, Hofmeester C, De Freitas DM, Mumford T, Nursey-Bray M, Kriwoken L, Shaw J, Shaw J, Smith T, Thomsen D, Wood D, Cannard T (2013) Enhancing the knowledge-governance interface: coasts, climate and collaboration. *Ocean Coast Manag* 86:88–99. <https://doi.org/10.1016/j.ocecoaman.2013.02.009>
- Danladi IB, Kore BM, Gul M (2017) Vulnerability of the Nigerian coast: an insight into sea level rise owing to climate change and anthropogenic activities. *J Afr Earth Sci*. <https://doi.org/10.1016/j.jafrearsci.2017.07.019>
- Davies-Vollum KS, West M (2015) Shoreline change and sea level rise at the Muni-Pomadze coastal wetlands (Ramsar site), Ghana. *J Coast Conser Manage* 19(4):515–525. <https://doi.org/10.1007/s11852-015-0403-y>
- Daudu AK, Oladipo FO, Olatinwo LK, Kareem WO (2020) Analysis of factors influencing vulnerability of fishing systems to climate change among Artisanal Fisher-folks in Coastal area of Lagos, Nigeria. *Afr J Land Policy Geospat Sci* 3(1):80–98. Retrieved from <https://revues.imist.ma/index.php/AJLP-GS/article/view/17924> (No DOI)

- Dey MM, Gosh K, Valmonte-Santos R, Rosegrant MW, Chen OL (2016) Economic impact of climate change and climate change adaptation strategies for fisheries sector in Fiji. *Mar Policy* 67:164–170. <https://doi.org/10.1016/j.marpol.2015.12.023>
- Djihouessi BD, Djihouessi MB, Aina MP (2016) A review of habitat and diversity research in Lake Nokue, Benin Republic: current state of knowledge and prospects for future research. *Ecohydrobiol* 19:131–145. <https://doi.org/10.1016/j.ecohyd.2018.04.003>
- Diop S, Sherin PA (2016) Sustainable oceans and coasts: lessons learnt from eastern and Western Africa. *Estuar Coast Shelf Sci* 18:327–339. <https://doi.org/10.1016/j.ecss.2016.03.032>
- Dossou KM, Glehouenou-Dossou B (2007) The vulnerability to climate change of Cotonou (Benin) the rise in sea level. *Environ Urban* 19(1):65–79. [https://doi.org/10.1007/978-94-007-7088-1\\_25](https://doi.org/10.1007/978-94-007-7088-1_25)
- Druyan L (2011) Review: studies of 21-century precipitation trends over West Africa. *Int J Climatol* 31:1415–1424. <https://doi.org/10.1002/joc.2180>
- Duck RW, de Silva JF (2012) Coastal lagoons and their evolution. *Estuar Coastal Shelf Sci* 110:2–14. <https://doi.org/10.1016/j.ecss.2012.03.00>
- Evadzi PIK, Scheffran J, Zurita E, Hunicke B (2018) Awareness of sea-level response under climate change on the coast of Ghana. *J Coast Conserv* 22:183–197. <https://doi.org/10.1007/s11852-017-0569-6>
- FAO (2018) The state of world fisheries and aquaculture 2018 – meeting the sustainable development goals. FAO. (No DOI)
- Freduah G, Fidelman P, Smith TF (2018) Mobilising adaptive capacity to multiple stressors: insights from small-scale coastal fisheries in the Western Region of Ghana. *Geoforum* 91:61–72. <https://doi.org/10.1016/j.geoforum.2018.02.026>
- GCLME (2006) Guinea current large marine ecosystem (GCLME)- transboundary diagnostic analysis: a programme of the governments of the GCLME countries under GEF/UNIDO/UNDP/UNEP/US-NOAA/NEPAD/FAO and IMO. (No DOI)
- GEF (1992) Coastal Wetlands Management Project, Republic of Ghana. Global Environment Facility. Project document, August 1992. World Bank. (No DOI)
- Ghana Embassy (2014) Population. <http://www.ghanaembassy.org/index.php?page=population>. (No DOI)
- Hastings RA, Rutterford LA, Freer JJ, Collins RA, Simpson SD, Genner MJ (2020) Climate change drives poleward increases and equatorward declines in marine species. *Current Biology* 30(8):1572–1577.e2
- Hauer ME, Fussell E, Mueller V et al (2019) Sea level rise and human migration. *Nat Rev Earth Environ* 1:28–39. <https://doi.org/10.1038/s43017-019-0002-9>
- IPCC (2014) In: Barros VR, Field CB, Dokken DJ, Mastrandrea MD, Mach KJ, Bilir TE, Chatterjee M, Ebi KL, Estrada YO, Genova RC, Girma B, Kissel ES, Levy AN, MacCracken S, Mastrandrea PR, White LL (eds) *Climate change 2014: impacts, adaptation, and vulnerability. Part B: regional aspects. Contribution of working group II to the fifth assessment report of the intergovernmental panel on climate change*. Cambridge University Press, Cambridge, UK/New York, p 688. (No DOI)
- Koomson D, Davies-Vollum KS, Raha D (2020) Characterising the vulnerability of fishing households to climate and environmental change: insights from Ghana. *Mar Policy* 120 (2020):104142. <https://doi.org/10.1016/j.marpol.2020.104142>
- Lam VW, Cheung WW, Reygondeau G, Sumaila UR (2016) Projected change in global fisheries revenues under climate change. *Sci Rep* 6:32607. <https://doi.org/10.1038/srep32607>
- Mauerhofer V, Kim RE, Stevens C (2015) When implementation works: a comparison of Ramsar convention implementation in different continents. *Environ Sci Pol* 51:95–105. <https://doi.org/10.1016/j.envsci.2015.03.016>
- Njifonjou O, Satia B, Angaman K (2006) Fisheries co-management and poverty alleviation in the context of the sustainable livelihoods approach: a case study in the fishing communities of aby lagoon in cote d’Ivoire. *Int J Sustain Dev World Ecol* 13(6):448–458. (No DOI)
- Niyonkuru C, Lalèyè PA (2010) Impact of acadja fisheries on fish assemblages in Lake Nokoué, Benin, West Africa. *Knowl Manag Aquat Ecosyst* 399:05. <https://doi.org/10.1051/kmae/2010033>



- Ochiewo J (2004) Changing fisheries practices and their socioeconomic implications in south coast Kenya. *Ocean Coast Manag* 47(7):389–408. <https://doi.org/10.1016/j.ocecoaman.2004.07.006>
- Odunga S, Badru G, Olalekan MB (2014) Climate change, sea level rise and coastal inundation along part of Nigeria barrier lagoon coast. *J Appl Sci Environ Manage* 18(1):41–47. <https://doi.org/10.4314/jasem.v18i1.6>
- Olawepo RA (2008) Using participatory rural appraisal to explore coastal fishing in Badagry villages, Nigeria. *Environmentalist* 28:108–122. <https://doi.org/10.1007/s10669-007-9052-5>
- Perry RI, Sumaila UR (2007) Marine ecosystem variability and human community responses: the example of Ghana, West Africa. *Mar Policy* 31(2):125–134. <https://doi.org/10.1016/j.marpol.2006.05.011>
- Rahmstorf S (2007) A semi-empirical approach to projecting Future Sea-level rise. *Science* 315:368–370. <https://doi.org/10.1126/science.1135456>
- Sagoe-Addy K, Appeaning Addo K (2013) Effect of predicted sea level rise on tourism facilities along Ghana's coast. *J Coast Conserv* 17:155–166. <https://doi.org/10.1007/s11852-012-0227-y>
- Scoones I (1998) Sustainable rural livelihoods: a framework for analysis. IDS working paper 72. <https://opendocs.ids.ac.uk/opendocs/handle/20.500.12413/3390>
- Short R, Gurung R, Rowcliffe M, Hill N, Milner-Gulland EJ (2018) The use of mosquito nets in fisheries: a global perspective. *PLoS One* 13(1):e0191519. <https://doi.org/10.1371/journal.pone.0191519>
- USAID (2014) Sustainable wetlands adaptation and mitigation programme: final report. [https://www.cifor.org/fileadmin/subsites/twincam/reports/SWAMP\\_Final\\_Report\\_2014.pdf](https://www.cifor.org/fileadmin/subsites/twincam/reports/SWAMP_Final_Report_2014.pdf). (No DOI)
- UN (2015) Transforming our world, The 2030 Agenda for Sustainable Development. <https://sustainabledevelopment.un.org/post2015/transformingourworld/publication>. (No DOI)
- Wiafe G (2010) Coastal and continental shelf processes in Ghana. NTIS technical report. University of Ghana, Accra. <http://www.onr.navy.mil/reports/FY11/lowaife.pdf>. (No DOI)
- Wiafe G, Boateng I, Appeaning-Addo K (2013) Handbook for coastal processes and management in Ghana. Gloucester: Choir Press, 274 p.
- World Bank (2019) West Africa's coast: losing over £3.8 Billion a year to erosion, flooding and pollution. <https://www.worldbank.org/en/region/afr/publication/west-africas-coast-losing-over-38-billion-a-year-to-erosion-flooding-and-pollution>. (No DOI)
- World Bank Group (2015) Economic, environmental, and social evaluation of Africa's small-scale fisheries environment and natural resources global practice policy note
- Zacarias DA (2019) Understanding community vulnerability to climate change and variability at a coastal municipality in southern Mozambique. *Int J Climate Change Strateg Manage* 11(1):154–176. <https://doi.org/10.1108/IJCCSM-07-2017-0145>

**Open Access** This chapter is licensed under the terms of the Creative Commons Attribution 4.0 International License (<http://creativecommons.org/licenses/by/4.0/>), which permits use, sharing, adaptation, distribution and reproduction in any medium or format, as long as you give appropriate credit to the original author(s) and the source, provide a link to the Creative Commons license and indicate if changes were made.

The images or other third party material in this chapter are included in the chapter's Creative Commons license, unless indicated otherwise in a credit line to the material. If material is not included in the chapter's Creative Commons license and your intended use is not permitted by statutory regulation or exceeds the permitted use, you will need to obtain permission directly from the copyright holder.





# Climate Change Implications and Mitigation in a Hyperarid Country: A Case of Namibia

# 109

Hupenyu A. Mupambwa, Martha K. Hausiku,  
Andreas S. Namwoonde, Gadaffi M. Liswaniso, Mayday Haulofu,  
and Samuel K. Mafwila

## Contents

Introduction .....	2248
Namibia: A Vast Place .....	2250
Aerosol Monitoring in Namibia and Its Importance .....	2250
Climate Change and the Oceans: Implications for Namibia .....	2252
Alternative Water Sources in a Hyperarid Namibia .....	2254
Availability of Water in Namibia .....	2254
Seawater Desalination in Namibia .....	2255
Alternative Food Sources under a Changing Climate: Mushrooms .....	2258
Climate Change Implications on Cultivation of Macrofungi in Namibia .....	2258
Current and Future Research on Mushrooms in Namibia .....	2259

This chapter was previously published non-open access with exclusive rights reserved by the Publisher. It has been changed retrospectively to open access under a CC BY 4.0 license and the copyright holder is “The Author(s)”. For further details, please see the license information at the end of the chapter.

H. A. Mupambwa (✉)

Desert and Coastal Agriculture Research, Sam Nujoma Marine and Coastal Resources Research Centre (SANUMARC), Sam Nujoma Campus, University of Namibia, Henties Bay, Namibia  
e-mail: [hmupambwa@unam.na](mailto:hmupambwa@unam.na)

M. K. Hausiku

Mushroom Research, SANUMARC, Sam Nujoma Campus, University of Namibia, Henties Bay, Namibia  
e-mail: [mkhausiku@unam.na](mailto:mkhausiku@unam.na)

A. S. Namwoonde

Renewable Energy Research, SANUMARC, Sam Nujoma Campus, University of Namibia, Henties Bay, Namibia  
e-mail: [anamwoonde@unam.na](mailto:anamwoonde@unam.na)

G. M. Liswaniso

Mariculture Research, SANUMARC, Sam Nujoma Campus, University of Namibia, Henties Bay, Namibia  
e-mail: [gliswaniso@unam.na](mailto:gliswaniso@unam.na)

© The Author(s) 2021

2247

W. Leal Filho et al. (eds.), *African Handbook of Climate Change Adaptation*,  
[https://doi.org/10.1007/978-3-030-45106-6\\_225](https://doi.org/10.1007/978-3-030-45106-6_225)

Organic Agriculture and Its Potential Under a Changing Climate .....	2261
Conclusions .....	2265
References .....	2265

## Abstract

Namibia is the most arid country in sub-Saharan Africa characterized by the existence of two deserts, the Namib and the Kalahari. However, though being arid, agriculture still plays a critical role in Namibia's economy, which includes both crop and animal production. Furthermore, the country is endowed with vast marine resources, with its marine waters being equivalent to two-thirds of Namibia's terrestrial environment. In the face of climate change and a growing population, there is a need for Namibia to continue with its climate smart efforts which is critical in shifting the country from its current dependency on imports thus increasing the country's food self-sufficiency. This chapter highlights the threats posed by climate change, both on land and the marine environment of the country, which has potential negative impacts on the economy. Current research being undertaken in Namibia on ocean acidification, sea water harvesting, climate smart agriculture, and atmospheric science, is also highlighted in this chapter. The information presented in this chapter will be critical in guiding climate change mitigation policies in hyperarid African countries, thus reducing the burden caused by the global change in climate. Aspects on the direction of future research on climate adaptation with a holistic and multidisciplinary approach are also proposed.

## Keywords

Climate smart agriculture · Aerosols · Shellfish · Marine environment · Clean energy · Seawater desalination

## Introduction

Namibia is a very unique country within Southern Africa, being the most arid country in this region characterized by the existence of two deserts, namely the Namib and the Kalahari deserts. On average, Namibia receives 270 mm of

---

M. Haulofu

Water Quality Research, SANUMARC, Sam Nujoma Campus, University of Namibia, Henties Bay, Namibia

e-mail: [mthomas@unam.na](mailto:mthomas@unam.na)

S. K. Mafwila

Oceanography Research, SANUMARC, Sam Nujoma Campus, University of Namibia, Henties Bay, Namibia

Department of Fisheries and Aquatic Science, Sam Nujoma Campus, University of Namibia, Henties Bay, Namibia

e-mail: [smafwila@unam.na](mailto:smafwila@unam.na)

rainfall annually, with a wide variation of between 20 mm and 700 mm from the western to the eastern parts of the country, with only 5% of the country receiving more than 500 mm of rain annually (Sweet and Burke 2006). Within this hyperarid environment, only 1% of the total surface of the country has medium to high potential for rain-fed crop production. Interestingly, agriculture plays a critical role in the formal and informal economy of Namibia, supporting up to 70% of the population, with 90% of this agriculture being livestock based (MAWF 2015). Due to its hyperaridity, Namibia imports most of its food crop requirements from other countries. However, with the advent of climate change which threatens Africa's food production potential, hyperarid and food (especially grain and vegetable crops) importing countries like Namibia will require intensive research on how to mitigate against the threats posed by climate change.

Namibia has achieved some key milestones towards its response to climate change. Firstly, by being party to the United Nations Framework Convention on Climate Change (UNFCCC), which meant it must institute policies and measures, informed by science, that reduce the changes on environment and humanity due to climate change (Mapaure 2011). In response to this, Namibia established the Namibian Climate Change Committee (NCCC) in 2001, to advise and make recommendations to government on issues of climate change. In 2011, Namibia developed the National Climate Change Policy (NCCP) which "outlines a coherent, transparent and inclusive framework on climate risk management in accordance with Namibia's national development agenda, legal framework, and in recognition of environmental constraints and vulnerability." (Lubinda 2015). In 2014, the country developed the National Climate Change Strategy and Action Plan for 2013–2020 which lays out guiding principles responsive to climate change that are effective, efficient, and practical (Lubinda 2015).

According to Mapaure (2011), Namibia has identified seven sectors where it is most vulnerable to climate change, and these include water resources; marine resources; agriculture; biodiversity and ecosystems; coastal zones and systems; and health and energy. Within the terrestrial agriculture environment, Namibia is most likely to experience more extreme weather patterns such as flooding and drought conditions under the changing climate. Furthermore, within the marine environment, it is predicted that the increase in northerly or easterly winds could result in suppressed upwelling in the nutrient-rich Benguela system, thus causing the accumulation of oxygen-poor water near the seabed and consequently suffocating marine life (Reid et al. 2008). Therefore, future changes in the distribution and intensity of winds under the changing climate have potential to negatively influence the fisheries sector of Namibia. Against this background, this chapter seeks to highlight some aspects critical for research on climate change in Namibia, while highlighting the current research being undertaken in Namibia at addressing climate change. This chapter focuses more on the coastal environment of Namibia, where climate change research on both terrestrial and marine environments is being championed at the Sam Nujoma Marine and Coastal Resources Research Center.

## Namibia: A Vast Place

Namibia is located in the southwestern part of Africa between the latitudes of 17.5° and 29° South, occupying a total land area of about 824,000 km<sup>2</sup>, with approximately 526,000 km<sup>2</sup> of ocean extending 200 nautical miles into the Atlantic Ocean (<https://www.unicef.org/namibia>). The country has a population of about 2.448 million people, making it one of the least populated country in the world. The country is characterized by a large coastal area, which covers the entire western border of the country with a length of about 1572 km. In Namibia, the cold Benguela Current has a moderating effect on regional weather patterns which are quite pronounced in the Namib desert, where it creates some unique climatic conditions. Just like most African countries, the contribution of Namibia to global atmospheric pollution responsible for climate change is very limited, though the effects of climate change will be quite pronounced. With Namibia's climate being already variable, climate change is expected to worsen this variability and amplify its adverse impacts (MET 2011). Therefore, with climate change, the focus for Namibia is more on mitigating its effects, which should be the focus of much research, as opposed to focusing on reducing greenhouse gas emissions as the country is not a serious contributor to this aspect.

---

## Aerosol Monitoring in Namibia and Its Importance

Climate change poses great danger to the livelihoods of many people in Africa and Namibia is not spared from this phenomenon. The country recently experienced the worst drought in decades, that peaked from 2018 to 2019, with some areas receiving none to sporadic precipitation accompanied with floods. Since climate change is driven by several factors, many of these factors are a product of interactions in the earth's atmosphere. Due to these atmospheric interactions, it is important to do long-term baseline aerosol measurement in areas predicted to suffer most from effects of climate change. Though Namibia, like most African countries, does not contribute much to atmospheric pollution, aerosols from global pollution which include black carbon (soot), sulfate, nitrate, ammonium, organic carbon, elemental carbon, and mineral elements can play a critical role in Namibia's climate. Aerosols are suspended particles in the atmosphere, their sizes range from fine (particle diameter < 1 µm) to coarse (particle diameter > 1 µm). Aerosols play several roles of climatic importance as they influence the amount of precipitation by acting as condensation nuclei for cloud formation, while others depending on their nature may scatter and absorb solar radiation thus affecting radiative forcing (Heintzenberg 1985). Aerosol radiative forcing is defined as the effect of aerosols on the radiative fluxes at the top of the atmosphere and at the surface and on the absorption of radiation within the atmosphere (Chung et al. 2005).

The western coast of southern Africa, where Namibia is central, experiences persistent and extended highly reflective clouds mainly stratocumulus and high loads of light-absorbing aerosols from various sources (Formenti et al. 2018).

However, the mechanisms by which the reflective clouds and light-absorbing aerosols interact to influence the regional radiative budget is largely unknown (Formenti et al. 2018). In other words, the function of aerosols and cloud processes on climate models is still unclear. Due to the importance of different aerosols on regional climate, a ground-based aerosol monitoring station was established in Namibia known as the Henties Bay Aerosol Observatory (HBAO) in 2011 under the University of Namibia at their coastal campus (Sam Nujoma Campus) in collaboration with the Laboratoire Interuniversitaire des Systèmes Atmosphériques (LISA), CNRS/Universities of Paris Est-Créteil and Paris Diderot, France, and the Climatology Research Group of the North West University (NWU), Potchefstroom, South Africa. This research station focuses on monitoring various parameters influenced by the aerosols. The data generated will form part of the atmospheric baseline studies in Namibia and the southern Africa region, which is important in filling the wide gap in climate change modelling in the region.

The contribution of greenhouse gases on climate change is well investigated, but due to the complex nature of aerosols, their contribution to climate still remains an area of interest to many scientists. As an arid country, Namibia's atmospheric precipitation could easily be affected by the nature of aerosols. If the amount of hydrophobic aerosols increases in Namibia, this could result in reduced rainfall and changes in the fog patterns in the country, which will negatively affect productivity of this arid but unique ecosystem.

In Namibia, the HBAO is monitoring the various properties of aerosols like those originating from the ocean (which generates microscopic salt particles by evaporation of water from sea-spray), wind-blown dust from the surrounding desert areas, dust from the various salt pans and aerosols generated by veld-fires, and smoke from ships using the Walvis Bay port. Aerosols from each of these sources will have a different composition, and different characteristics such as size, light's absorption capacity, and reflectivity.

In a 3-year study at the HBAO, measurement of mass concentration of equivalent black carbon (eBC, which is a light-absorbing aerosol from biomass burning), it was noted that these aerosols have seasonal shifts that coincide with fire seasons in southern Africa (Formenti et al. 2018), a clear indication that regional sources have contributed to the observations. In addition to these long-term measurements at the HBAO station, an intensive field campaign named the Aerosol Radiation and Clouds in southern Africa (AEROCLO-sA) project using ground-based equipment and a SAFIRE F20 research airplane was conducted in August to September 2017. The results from AEROCLO-sA field campaign are summarized by Formenti et al. (2019). Even though the sources of aerosols in Namibia are less studied, local and subcontinental sources may contribute to the observed measurements since finer aerosols are transported over a long distance. The southwestern African areas experience persistent stratocumulus cloud deck, which increases the total of outgoing radiation, resulting in a generally cooler atmosphere. Increased amount of eBC will therefore result in warmer atmosphere and may affect cloud formation in the region.

With the projection of increased emission in the world, Namibia is in a region that is predicted to experience rising temperatures and it is expected that a large portion

of the country will see lowered rainfall with increased number of dry days consequently affecting agricultural productivity negatively. In addition, in desert and coastal areas the rate of fog production may be impacted resulting in less water for plants and animals in these areas. The overall effects of aerosols on climate can be complicated to predict, it is only a long-term observation that can assist in modeling and predicting the climate change regionally and globally.

## Climate Change and the Oceans: Implications for Namibia

Rising atmospheric carbon dioxide (CO<sub>2</sub>) concentrations became evident after the industrial revolution in the 1800s as a result of increased anthropogenic activities such as combustion of fossil fuels, agriculture, iron and steel production, municipal solid waste combustion, cement manufacturing, deforestation, and other activities that contribute to emissions of greenhouse gases. The industrial production of CO<sub>2</sub> since the 1800s has increased the atmospheric CO<sub>2</sub> concentration from 280 parts per million (ppm) to 396 ppm, and continued increases are predicted to reach 800 ppm by the year 2100 (Branch et al. 2013).

The current atmospheric CO<sub>2</sub> concentration is rising at an increased annual rate of 0.5%, that is 100 times faster than any change during the past 650,000 years. The global oceans absorb 25% of the CO<sub>2</sub> released into the atmosphere, from the various listed human activities. The increased absorption of CO<sub>2</sub> by the oceans has caused changes in the oceanic chemistry where the concentration of dissolved CO<sub>2</sub> has been increasing and consequently resulting in ocean pH decrease. This reduction in pH, as seawater becomes more acidic, is predicted to decline from approximately 8.2 during the preindustrial era to 7.8 in the 2100 s (Wei et al. 2014).

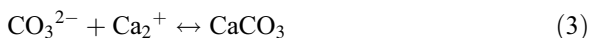
When CO<sub>2</sub> is absorbed by seawater, a series of chemical reactions occur resulting in the increased concentration of hydrogen ions which causes the seawater to become more acidic and causes carbonate ions to be relatively less abundant. The solubility and distribution of CO<sub>2</sub> in the oceans highly depends on climatic conditions and other physical (e.g., water column mixing, temperature), chemical (e.g., carbonate chemistry), and biological (biological productivity) aspects. Assimilation of CO<sub>2</sub> into the ocean occurs via the ocean surface to air interface, where CO<sub>2</sub>(aq) will react with surface seawater to form a weak carbonic acid (H<sub>2</sub>CO<sub>3</sub>) that quickly dissociates into hydrogen ions (H<sup>+</sup>) and bicarbonate (HCO<sub>3</sub><sup>-</sup>) ions, as indicated in the Eqs. (1) and (2) (Doney 2006).



Some of the free hydrogen ions (H<sup>+</sup>) combine with free carbonate (CO<sub>3</sub><sup>2-</sup>) ions normally found in seawater to form more bicarbonate (HCO<sub>3</sub><sup>-</sup>).



This chemical reaction uses up important ocean carbonate ( $\text{CO}_3^{2-}$ ) molecules needed by some organisms, such as mussels and oysters, to form shells. In addition, the increased acidity of the ocean, caused by the free hydrogen ions ( $\text{H}^+$ ), causes shells to deteriorate, become thin and frail. Shells in marine organisms are formed by taking up carbonate and calcium in seawater to form calcium carbonate, or the tough cement-like layer we know as a shell, as illustrated in Eq. (3).



Ocean acidification currently holds the world's attention due to the predicted adverse effects it poses on the marine ecosystems. Monitoring for ocean acidification is crucial in that it allows for forecasting future trends.

Ocean acidification is expected to impact marine species at varying degrees. While microalgae like dinoflagellates and diatoms may benefit from higher  $\text{CO}_2$  conditions in the ocean, it has dramatic effects on calcifying species, such as oysters, clams, sea urchins, corals, and calcareous plankton. Increased sequestering of atmospheric  $\text{CO}_2$  in the ocean would result in a lowering of the oceanic carbonate equilibrium. Carbonate ions are important building blocks for structures such as seashells and coral skeletons. Calcifying organisms such as corals are important in the ecosystem as they provide habitat and shelter to various marine organisms and their demise would endanger survival of most of those housed species. There are also other calcifiers that are vital food sources for most marine organisms. Since the calcification of seashells and coral reefs depends on the saturation of the carbonate mineral known as aragonite, it has been suggested that increasing atmospheric  $\text{CO}_2$  could result in a decrease in the aragonite saturation state in the ocean by 30% (Takeo et al. 2012).

Namibia has a coastline that is largely uninhabited, unpolluted, and highly productive waters due to upwelling of the Benguela system. Upwelling systems are naturally acidic due to vertical movement of  $\text{CO}_2$ -rich deep waters to the surface and the acidity is increasing due to increased anthropogenic carbon dioxide that is being absorbed by the ocean. These upwelling systems are expected to undergo major changes in the near future due to steadily increasing atmospheric  $\text{CO}_2$  and the resultant consequences on the ecosystem and fisheries are unknown. Mariculture in Namibia is reliant on shellfish culture with oyster farming being the most established activity, producing both the Pacific and Eastern oyster. Studies have shown how vulnerable mollusks are to acidification but there is still limited data on its impacts in Namibian waters (Waldron et al. 2009). Further research on the effects of ocean acidification on shellfish is being undertaken at the Sam Nujoma Marine and Coastal Resources Research Center, which promises better understanding of this phenomenon on marine life.

The Pacific oysters are farmed in Swakopmund, Walvis Bay, and Lüderitz (now known as !Nami#Nûs). This industry is already under threat from the harmful algal blooms (HABs) that frequently occur along the Namibian coastline attributed by high plankton biomass decay that ultimately leads to anoxic events and in some cases eruptions of hydrogen sulfide from the seabed that led to 80% mortality of



marine shellfish farmed in Namibia (Anderson et al. 2004). In 2008, sulfur eruptions impacted Walvis Bay marine shellfish farms leading to closure of some farms and relocation of other farms to Lüderitz (OLRAC 2009). With the Namibian marine industry already being influenced by the HAB, ocean acidification of the Southern Atlantic poses a far much greater threat to this industry.

Villafañe et al. (2015) indicated that the predicated ocean acidification conditions, with increased nutrient and solar radiation could lead to the reshaping of the phytoplankton community, where it would have phytoplankton communities dominated by large diatoms with high growth rates and therefore marine phytoplankton could bloom more efficiently under future acidified conditions than the current conditions. Similarly, when conditions favor phytoplankton, it also infers good conditions for growing seaweed. This would also suggest that the Namibian mariculture industry would lose high-income businesses from oyster culture, loss of employment, and subsequently reduced contribution to the country's GDP. Most businesses would have to shift into seaweed culturing as this will utilize the abundant nutrients, solar radiation, and CO<sub>2</sub> in the Benguela upwelling system. Therefore, research that already looks at macro-algae culture for extraction of highly priced phytochemicals is important in Namibia.

Previous research has found out that influxes of iron from terrestrial origin into the ocean led to increased bloom activity in primary productivity (Pollard et al. 2009). Research that involves fertilizing certain oceanic regions with iron, as it is mostly a limiting nutrient, to enhance the sequestering of carbon onto the ocean floor can be critical in mitigating against increased CO<sub>2</sub> concentration in the ocean. The resulting blooms would counteract the growing concern of dissolved CO<sub>2</sub> and produce organic carbon that would sink to the ocean floor. Norton (2011) suggested the addition of powdered limestone to the ocean in order to react with the dissolved CO<sub>2</sub> as another potential mitigation to ocean acidification. As the limestone reacts with the CO<sub>2</sub> this will form bicarbonate which would in turn neutralize the acidic conditions of the ocean. These counter action would make calcium carbonate more available in seawater and readily available to calcifying organisms to build their shells. The process of increased calcium carbonate would increase the buffering capacity of the ocean and limit the sequestration of CO<sub>2</sub> by the oceans. However, though these researched measures are theoretically feasible, their practicality still requires lot of practical field-based research.

---

## **Alternative Water Sources in a Hyperarid Namibia**

### **Availability of Water in Namibia**

Due to pressures from climate change, global water resources have become vulnerable and scarce, and Namibia is not spared from this phenomenon. Water is a significant resource to human life, the environment and for development, but it is finite. Scientific consensus is that climate change will have a pervasive influence on the future demand, supply, and quality of fresh water resources in Namibia, and

would add pressure to already stressed water resources and coastal environments (Lahnsteiner and Lempert 2007). Namibia frequently receives below average and highly variable rainfall with high temperatures that result in very high evaporation rates of between 2660 and 3800 mm per year, which makes Namibia one of the driest in sub-Saharan Africa (FAO 2005). More specifically, the central Namib Desert consists of a flat, gently sloping plain with few topographic features. The steady gradients affect rainfall, temperature, and wind patterns developing between the coast and the interior. The annual mean rainfall along the coast between Swakopmund and Henties Bay is less than 15 mm per annum, with coastal wind speeds averaging approximately 3 m/s in a south westerly direction (Pryor et al. 2009). Likewise, due to climate change, the occurrence of droughts has become more frequent and requires appropriate water management to ensure continued social and economic development of the country (COW 2019). Due to extremely poor rainfalls, the recent drought of the 2018/2019 rainfall season resulted in huge economic losses to the Namibian farmers as livestock and crops died due to lack of water.

The rainfall received accounts for only 2% and 1% surface runoff and groundwater recharge, respectively, while 97% is lost through high evaporation rates in Namibia (Christelis and Struckmeier 2011). The difference between national and regional averages reveals the growing need to seek and implement alternative water supply strategies, in order to secure adequate fresh water and cater for future demand in Namibia under a changing climate. Namibia relies heavily on underground water (aquifers) for the supply of fresh water, which are recharged not only by the rainfall from catchment areas within the country but also from neighboring countries. With such heavy reliance on underground water, particularly in the North Central Regions, the water is at times unsuitable for human and animal consumption due to high salinity (Wilhelm 2012). Climate change is expected to exacerbate this reliance on aquifers for fresh water due to limited recharging of underground water sources. Changes in rainfall and runoff further indicate that underground water recharge may suffer a reduction of 30–70% across Namibia. In order to adapt to the reduction in freshwater resources, other arid countries including Namibia have begun sea water desalination as a feasible source of fresh water. The reliance is expected to grow as a result of population growth and migration to coastal cities which do not have adequate freshwater resources. In Namibia, the coastal population's overdependence on aquifers constitutes its vulnerability to climate change. However, the vast coastal area of Namibia is also characterized by cool yet sunny environments, rough seas, and very windy areas, all which can be potential energy sources for powering the energy demanding and costly desalination process. Desalination would be a strategic alternative to ensure long-term freshwater supplies, more so when using renewable, clean energy sources for desalination.

## **Seawater Desalination in Namibia**

On earth, about 70% of the area is covered by water which is mainly seawater, with only about 1% of the freshwater being available for human consumption and for

agricultural purposes in the world's rivers, lakes, and aquifers (Darre and Toor 2018). The scarcity of fresh water resources and the need for additional fresh water supplies are critical in many arid regions of the world (Michou 2017). Worthy to note are the countries in the Arabian Gulf, which are located in an arid area with limited water resources. The region has the lowest availability of renewable water resources per capita in the world. To curb this shortage, the gulf countries invested in seawater desalination technologies that would ensure an adequate supply of freshwater for industries and the more than 300 million inhabitants. To date, the largest market for water desalination in the world is found in the Arabic Gulf (Ramadan 2015).

Even though it offers a sustainable solution to water woes, desalination is energy intensive and comes with environmental consequences. About 0.4% of the world's electricity consumption is taken up by desalination plants, with global emissions due to nonrenewable energy use in desalination, predicted to reach 400 million carbon equivalents per year. The carbon footprint for reverse osmosis (RO) desalination has been calculated to be between 0.4 and 6.7 kg CO<sub>2</sub>eq/m<sup>3</sup>. This means that desalinating 1000 cubic meters of seawater could potentially release as much as 6.7 tons of CO<sub>2</sub> (Tal 2018), hence efforts to produce freshwater should not forgo environmental safety. Desalination technologies must be enhanced to become cleaner and more efficient (Compain 2012).

Desalination needs are mainly in dry countries that receive high-intensity solar radiation, hence it makes sense in Namibia to exploit solar power for desalination. Namibia is a country which is abundantly rich in solar energy, as it receives on average of 300 days of sunshine per year, with very few cloudy days. Harnessing this energy from the sun would make it possible to supply the power needed to run desalination plants. The available solar energy makes research and development in solar desalination promising for Namibia. Although at present, renewable resources in Namibia play a very small role in the energy sector, there is potential for renewables to scale up in providing for non-electricity energy sectors. Other alternative and cost-effective sources of renewable energy can also be used for desalination. Renewable energy sources such as wind can be used to generate electricity for use in desalination plants as an alternative to for thermal electric plants. The above alternatives are already being explored in the east coast of Egypt where water resources are limited.

In Namibia, the first desalination plant belonging to Orano Mining Namibia was commissioned in 2010. The desalination plant was originally built to supply water to the Trekkopje Mine near Arandis but has now become part of the potable water delivery system belonging to Namibia's water utility, NamWater. The addition of desalinated water has allowed NamWater to keep meeting the Central Namib's water demand as it provides about 75% of the overall drinking water to the coastal town of Swakopmund, as well as the nearby uranium mines and other industries (Petrick and Müller 2019). Furthermore, communities of Akutsima and Amarika in the Omusati Region of Namibia benefited from small-scale solar powered desalination plants under the CuveWaters project. These plants aimed to supply the local population with safe drinking water by desalinating saline underground water. This was seen as

a sustainable way of supplying safe drinking water to the local community, who for years consumed unsafe and salty water.

In an effort to reduce the carbon footprint of desalination, the University of Namibia piloted a 100% solar powered desalination plant that uses reverse osmosis technology. The pilot desalination plant is evaluating the feasibility of using renewable solar energy for seawater desalination in Namibia's coast. This pilot research project generates approximately 2300 L of fresh water per hour, which can be very sustainable for supplying water to local communities. Preliminary results of an assessment to determine the mineral composition and grade class of the desalinated water produced at the University of Namibia (UNAM) are presented in Table 1, which point to the suitability of this water for drinking and irrigation according to National and WHO standards.

With this research solar powered plant, the University of Namibia seeks to evaluate various scenarios which include:

- The short- and long-term suitability of solar power in water desalination in the Namibian coast.
- The potential of using this clean energy produced fresh water in desert greening and food production.
- The potential of using desalinated water in enhancing Namibia's contribution to carbon sequestration by using the water to irrigate high carbon fixing trees.
- The potential of accruing carbon credits using various indigenous and exotic tree species irrigated using desalinated water in Namibia.

**Table 1** Preliminary results on the mineral composition and grade class of UNAM desalinated seawater

<i>Physical constituents</i>	UNAM	National limits	WHO limits	Units	Grade	Classification
pH	5.9	6–8.5	6.5–8.5		B	Good
Turbidity	0.3	<0.3	< 4	(NTU)	A	Excellent
Conductivity	45.2	<80	<sup>a</sup>	(mS/m)	A	Excellent
Total hardness as CaCO <sub>3</sub> (mg/L)	7	<400	<sup>a</sup>	mg/L	A	Excellent
<i>Mineral constituents</i>						
Sodium as Na (mg/L)	55	<100	200	mg/L	A	Excellent
Potassium as K	3	< 25	<sup>a</sup>	mg/L	A	Excellent
Nitrate as N (mg/L)	<0.5	< 6	< 50	mg/L	A	Excellent
Nitrite as N	<0.1	< 0.1	< 3	mg/L	A	Excellent
Fluoride as F (mg/L)	<0.1	< 0.07	1.5	mg/L	A	Excellent
Iron as Fe (mg/L)	0.01	< 200	<0.3	mg/L	A	Excellent
Calcium as CaCO <sub>3</sub> (mg/L)	<3	< 80	200	mg/L	A	Excellent

<sup>a</sup>Occurs in drinking water at concentrations well below those of health concerns (WHO 2009)

## Alternative Food Sources under a Changing Climate: Mushrooms

Though Namibia is an arid country, with very limited terrestrial productivity, there has been a growing interest on mushrooms (edible macrofungi) as an alternative high-value food under the changing climatic environment. Edible macrofungi are highly nutritious with numerous therapeutic benefits as they are rich in proteins, minerals, and vitamins such as B, C, and D (Reeta and Dev 2019). In Namibia, foraging for edible macrofungi is done seasonally just like elsewhere in sub-Saharan Africa (Wahab et al. 2019). Edible macrofungi are mostly foraged for personal consumption but some individuals sell them for a small price, pointing to their potential economic value. Interestingly, those who sell them are unwilling to profit from their sale as they believe that macrofungi are God's given gift (Mshigeni 2001).

Just like other wild crops in Namibia, the availability of macrofungi is influenced by rainfall, with too little or too much having a negative effect on their distribution and abundance. Ethno-mycological studies have reported that Namibian people are aware of the link between the appearance of macrofungi with rainfall, since they refer to the macrofungi as products of a "lightning bird," because they appear after thunderstorms (Trappe et al. 2010). Of recent, wild edible macrofungi are diminishing with unpredictable rainfall events. The unusually heavy rains within a short period, followed by extended drought periods, is reducing the natural growing season of mushrooms. There is therefore a need to shift from the traditional way of exploiting this resource under a changing climate by focusing on cultivation technology. Mushroom cultivation has potential to contribute to diversification of traditional farming in Namibia. Despite the global trend in domestication and cultivation of macrofungi, the focus in Namibia to date has been on the cultivation of the exotic oyster mushrooms (Hausiku and Mupambwa 2018). Even with the oyster mushroom, their cultivation is still on a subsistence scale, partly due to shortages of suitable substrate. As for the indigenous macrofungi, a limited number of research has been done on characterizing their chemical properties and their domestication studies are still in infancy stage if there are any.

### Climate Change Implications on Cultivation of Macrofungi in Namibia

Since macrofungi thrive underground or within substrate during their vegetative stage, their direct response to climate change is challenging to characterize. Consequentially, the timing of their fruit body production is used to study their phenological response to climate change (Bidartondo et al. 2018). Sato et al. (2012) defined phenology as the seasonal timing of life-history events of organisms (in this case, macrofungi). For the Namibian macrofungi, the only documented phenological response to climate change is that of the *Kalaharituber*, also known as Kalahari truffle (Mshigeni 2001; Leistner 1967) showing a later and shorter fruiting period. This observation is in agreement with long-term datasets documented elsewhere showing that the lengths of the macrofungi-producing season and their timing have

changed relative to the changes in temperature and rainfall, as have their diversity and range (Bidartondo et al. 2018). It can therefore be deduced that the rising temperature and reduction in precipitation observed in Namibia over the years is having similar effects on macrofungi productivity in Namibia. Studies carried out in the laboratory confirm that temperature and moisture availability affect both the vegetative and fruiting stage of macrofungi. Mycelial growth has been reported to increase with temperature until an optimum temperature is reached, thereafter, the growth decreases (Fletcher 2019). Similar response has been observed in the presence of moisture, whereby insufficient or excessive moisture limits fungal growth. According to Wahab et al. (2019), the average optimal temperature and humidity for mushroom fruiting is around 20 °C and 80%, respectively.

### Current and Future Research on Mushrooms in Namibia

The projected further increase in temperature and sporadic rainfall patterns coupled with extreme weather events are likely to threaten the already dwindling macrofungal resources of socioeconomic value in Namibia. A few studies have been documented on Namibian macrofungi as summarized in Table 2, and a lot more need to be done in terms of research.

From Table 2, it is obvious that Namibian macrofungi are understudied. All the documented studies on the edible macrofungi (*Termitomyces* and *Kalaharituber* species) were done on specimens that were bought from the market. Further studies are needed to address the distribution, ecology, phylogeny, pharmacology, phenology, chemical characterization, and domestication trials.

More studies are documented on nonedible macrofungi (*Trametes*, *Pycnoporu*, and *Ganoderma* species) compared to the edible ones. These studies addressed the phylogeny, indigenous knowledge, and the utilization of these fungi. Further studies are needed to zoom into the biochemical properties of the fungi to isolate and quantify the bioactive compounds responsible for their therapeutic effects reported by the respondents during these studies. Phenological studies would give an idea on the effect of climate change on the different species. Domestication trials would facilitate intensification of research on the fungi as field studies tend to be time-consuming and expensive.

Namibian mycologists are thus urged to make an effort to domesticate indigenous macrofungal species, especially the edible ones that have largely been neglected by science. Domestication and cultivation will ensure that availability of this resource is not dictated by precipitation or climate. It has been demonstrated by research that cultivation of macrofungi depends on agro-industrial material (e.g., cereal straws, wood chips, etc.) for substrate, and these materials are usually rain fed implying that drought effects on substrate material will trickle down to mushroom productivity. Recent research has been exploring the potential of using marine biomass as a source of organic material to be used as mushroom substrate. In a study by Hausiku and Mupambwa (2018), beach-casted seaweed was used to supplement rice straw in order to fruit oyster mushrooms. The incorporation of seaweed into substrate did not

**Table 2** A summary of studies that have been done on indigenous macrofungi in Namibia

Macrofungal species	Type of study	Guide for future studies
<i>Termitomyces schimperi</i> and <i>Kalaharituber pfeilii</i>	Antimalarial properties of <i>Termitomyces schimperi</i> and <i>Kalaharituber pfeilii</i>	Distribution, ecology, phylogeny, pharmacology, phenology, chemical characterization, antimicrobial activities, domestication trials.
	Characterization of polysaccharides isolated from <i>Termitomyces schimperi</i> and <i>Kalaharituber pfeilii</i>	
	Characterization of laccase enzymes from <i>Termitomyces schimperi</i> and <i>Kalaharituber pfeilii</i>	
	Antiplasmodial activity of <i>Terfezia pfeilii</i>	
	Morphological characterization of <i>Termitomyces schimperi</i> from herbarium specimens	
General macrofungi	Survey of Namibian macrofungi	Spatial and temporal distribution and habitats of the different species, phylogeny, phenology over time
<i>Trametes</i> and <i>Pycnoporus</i>	Phylogeny of <i>Trametes</i> and <i>Pycnoporus</i> using ITS	Biochemical characterization, phenology, domestication trials
	Ethnomycology of indigenous <i>Trametes</i> species	
<i>Ganoderma lucidum</i>	Antimalarial properties of <i>Ganoderma lucidum</i>	Distribution of the fungus over time. Characterization and quantification of bioactive compounds
	Minerals and trace elements in <i>Ganoderma lucidum</i>	
	Evaluation of substrate for the production of <i>Ganoderma lucidum</i>	
	Antimicrobial screening of crude extracts from <i>Ganoderma lucidum</i>	
	Antiplasmodial activity <i>Ganoderma lucidum</i>	
	Traditional medicinal uses and natural hosts	
	Genetic diversity of <i>Ganoderma</i>	
	Distribution, genetic diversity, and uses of <i>Ganoderma</i>	

only add value to the beach-casted seaweed but enhanced the nutritional benefits of the mushrooms.

Identification, collection, and domestication of native wild mushrooms is another aspect of fungal science that have been overlooked. Such studies are imperative in facilitating taxonomical and ethno-mycological studies of indigenous macrofungi. Furthermore, documentation on the traditional use of Namibian macrofungi and assessment of their local and international markets would expedite their industrial

relevance (Shahtahmasebi et al. 2018). Besides domestication, value addition of macrofungi with socioeconomic importance such as the *Termitomyces* and the *Kalaharituber* is important. Food technologists need to find ways to increase the shelf life of this highly perishable commodity by creating new products that are different from the traditional forms in which macrofungi are consumed in order to contribute to the country's GDP.

---

## Organic Agriculture and Its Potential Under a Changing Climate

With Namibia being an arid country, terrestrial biomass production is very limited, which has consequently resulted in very poor quality soils in most parts of the country. The soils in Namibia therefore lack fertility as they are mostly sandy and very old (Zimmermann et al. 2017). Under natural conditions, terrestrial biomass results in the generation of huge quantities of organic matter which is deposited into the soil, where it becomes part of soil organic carbon. Soil organic carbon or soil organic matter plays a critical role in soil quality, with the following functions:

- The non-humic substances produced during the decomposition of organic matter, e.g., polysaccharides encourage granulation – the binding of soil particles into aggregates. These aggregates help to maintain a loose, open, granular condition. This improves the aeration and water infiltration capacity of the soil.
- Organic matter can hold up to 20 times its weight in water. Its presence in the soil, therefore, improves the soils' water holding capacity. This is especially important in sandy soils.
- Organic matter (humus colloids) has a high cation exchange capacity (2–30 times as great (per kg) as that of various types of clay minerals). It therefore adsorbs and stores plant nutrients ( $K^+$ ,  $Ca^{2+}$ ,  $Mg^{2+}$ , etc.) and thus improves the fertility of soil.
- Humus colloids form stable complexes with  $Cn^{2+}$ ,  $Zn^{2+}$ ,  $Mn^{2+}$ , and other polyvalent cations. This may enhance the availability of micronutrients to higher plants.
- Decomposition of soil organic matter release  $NH_4^+$ ,  $NO_3^-$ ,  $PO_4^{3-}$ , and thus serves as a source of nutrients to plants.
- Organic matter serves as a source of energy for both macro- and microfaunal organisms. These organisms in turn play important roles in soils, e.g., earthworms which are important agents for good soil structure, bacteria responsible for mineralization processes, etc.
- Humic acids also attack soil minerals and accelerate their decomposition, thereby releasing essential elements as exchangeable cations.
- In very acid soils, organic matter alleviates aluminum toxicity by binding  $Al^{3+}$  ions in nontoxic complexes

Soils with low organic matter are therefore prone to degradation and this is the major cause of reduced agricultural productivity and food security in countries



like Namibia. With poor quality soils mainly due to low organic matter content, much of Namibian agriculture is more at risk of the effects of climate change such as reduced rainfall, flooding, increased environmental temperature among others, which will require more resilient soils.

From the Namibian perspective, a shift from the conventional agriculture that replicates the green revolution technologies such as intensive use of fertilizers, pesticides, and machinery is required, towards more organic-based agriculture systems is important. The current conventional agriculture practices have not focused on soil fertility but rather only on the crop fertility, which has actually seen crops yields in most parts of the country decreasing in the face of climate change. Organic agriculture practices are among some of the systems that are being promoted among others like ecological agriculture, sustainable intensification, and conservation agriculture, as these systems focus more on feeding the soil making it more resilient under climate change (Mupambwa et al. 2020). Organic agriculture is a more holistic production system which promotes agroecosystem health approach which promotes the use of management practices in preference to the use of off-farm inputs (FAO/WHO 1999).

Zimmermann et al. (2017) highlighted that Namibia has important resources that can be used in organic soil fertility which include animal manures, fertilizer trees harvestable from nature; marine resources such as seaweeds; bird guano and animal processing waste such as blood, bones, and fish waste. Technologies like composting and vermicomposting can be used in improving the fertilizer value of these waste materials, which can then be used as soil amendments. Current research being undertaken in Namibia on developing organic nutrient-rich fertilizers includes the optimization of the biodegradation and nutrient release during vermicomposting of various household waste, marine biomass, and farm waste materials. Such research is important in standardizing the production processes of organic fertilizers, thus allowing for greater uptake of these fertilizers among smallholder farmers. The lack of nutrient predictability and standardization of organic fertilizer production results in even those that are commercially available on the market being sold without any labeling that indicates nutritional composition as is mandatory for inorganic fertilizers. The specification of compost quality is more important as it enables compost users to more effectively manage their agroecosystems (Mupambwa and Mnkeni 2018).

Several researchers are undertaking research that is linked to organic agriculture in Namibia and these are summarized in Table 3 below.

Research on uses of organic soil fertility conditioners is currently happening in Namibia, though not much of it is not directly linked to mitigating the effects of climate change. There is a need to marry the two, so that such research can directly fit into the National Climate Change Strategy and Action Plan for 2013–2020 of Namibia. It is also important to note that there is very limited research available for Namibia on evaluating the potential of organic agriculture in improving soil quality, though several reviews are available on this subject.

**Table 3** A summary of some of the studies that have focused on aspects relating to organic agriculture in Namibia

Study details and location	Key results	Climate mitigation effects	Future research	Reference
The study evaluated the used of three rates of cattle manure at 0, 31, and 62 Mg/ha within three cropping systems, i.e., pearl millet ( <i>Pennisetum glaucum</i> L.) mono-cropping; cowpea ( <i>Vigna unguiculata</i> L.) mono-cropping; and pearl millet-cowpea intercropping. The soil was a sandy soil from Ogongo, Omusati Region with a pH (H <sub>2</sub> O) = 7.0 and 2.8 g total C/kg soil.	Application of manure increased soil organic carbon by 1.3 and 1.7 times under the 31 and 62 Mg/ha, respectively. Furthermore, manure application significantly increased the concentration of most macronutrients compared to the control. However, cropping system did not result in differences in most of these parameters. The study also observed that there was optimization on the benefits of manure addition at the lower rate of 31 Mg/ha.	Soil organic carbon (SOC) can be significantly increased by addition of cow manure, which has the potential to improve soil quality in sandy degraded soils. Higher SOC increases the resilience of soils and improves water and nutrient retention, which has potential to increase yields under smallholder farmers.	There is need to improve the quality of the manure applied through processes such as composting and vermicomposting and evaluating these improved organic nutrient sources. There is need for long-term studies evaluating the influence of animal manures on soil quality, which considers changes soil chemical, biological, and physical properties. Optimization of long-term application rates of animal manures which is informed by crop requirements is essential.	Watanabe et al. (2019)
The study evaluated an organic hydroponic nutrient solution prepared from goat manure processed through composting goat manure for 6 months and then extracting the nutrients from the compost by a process of leaching for 7 days. The study	The use of organic hydroponic solution did not result in significant differences in vegetative plant growth with the commercial hydroponic fertilizer, which were all different from the control with the lowest vegetative growth. In terms of yield parameters,	Important vegetable crops like tomatoes can be grown in under hydroponic systems that are fertilized using organic nutrient sources. The use of hydroponics which are cheap allows for the production of crops under the smallholder farmers with limited water use	Evaluating more nutrient-rich compost types called vermicomposts as hydroponic nutrient sources. Evaluating the effectiveness of using amendments like rock phosphate, fly ash, and biochar in improving the fertilizer value of these organic nutrient sources.	Mowa (2015) and Mowa et al. (2017)

(continued)

**Table 3** (continued)

Study details and location	Key results	Climate mitigation effects	Future research	Reference
<p>had three treatments, i.e., the organic hydroponic fertilizer; a commercial hydroponic fertilizer, and a control of water alone. A floating deep water culture hydroponic system was then used for growing tomatoes. The study was done in a greenhouse in Henties Bay located within the coast of Namibia.</p>	<p>tomato plants grown under the commercial hydroponic fertilizer produced more than those grown under manure nutrient solution which in turn, produced more than the plants grown under the control.</p>	<p>and low fertilizer costs. Hydroponics are critical in increasing food production under a changing climate, where fresh water will become scarce.</p>		
<p>The study was undertaken in Kavango East Region (Mashare Irrigation Training Center – MITC) and Zambezi Region (Liselo Research Station – LRS). Two experiments one with pearl millet (<i>Pennisetum glaucum</i>) and the other with maize (<i>Zea mays</i>); which were rotated with different Green Manure Cover Crops (GMCC) to evaluate their effects on the productivity (grain and biomass yields) among other parameters.</p>	<p>The GMCC lablab resulted in the highest biomass yield with a mean yield of 11,500 kg/ha while jack bean had the lowest yield of 1000 kg/ha. Similarly, lablab in the pearl millet rotation resulted in the greatest grain yield of 3 tonnes/ha, with jack bean, bambara nut, and common sun hemp producing lower grain yields. At LRS, the greatest biomass yield was observed in the velvet bean treatment with a mean yield of 5900 kg/ha.</p>	<p>Green manure cover crops can significantly contribute to the addition of soil organic matter thus increasing the soil organic carbon of the soil, which consequently improves soil quality. The legume green manure cover crops can be effective in fixing atmospheric N into the soil, thus reducing the use of inorganic fertilizers.</p>	<p>Monitoring the long-term contribution of the GMCC to overall soil quality under various combinations. Evaluating the potential of agroforestry tree species in agroecology in Namibia.</p>	<p>Amakali (2019)</p>

## Conclusions

The contribution of Namibia and most countries in southern Africa to climate change through the global increase in atmospheric pollutants that are drivers of global warming is very minimal. However, it is apparent that the impacts of this global change in climate due to human-induced activities will influence everyone on earth, with the effects expected to be even more pronounced in already hyperarid countries like Namibia. Namibia has made huge progress at policy level with regards to issues of climate change. However, there is need for more urgent research that directly feeds into the climate change strategy and action plan for Namibia. This research will need to focus on understanding more on the effects of anthropogenic activities on the atmosphere, water, and land activities, in a holistic manner. With the country being hyperarid, research that is currently underway on using clean energy sources like solar, wind, and tidal power for sea water desalination can be critical in abetting the effects on climate change on fresh water availability in Namibia. However, there is need for research on engineering locally adaptable technologies that can take this fresh water from the coast to other places of the country for use in agricultural activities, thus creating green belts in Namibia, capable of improving the country's food self-sufficiency. With Namibia being blessed with a vast marine environment, research on the effects of climate change on this unique marine environment and how it will affect economic activities in this industry will also be critical. Overly, Namibia is making progress on generating research critical in mitigating against climate change, and the future will require more research with a multidisciplinary approach to feed into the country's climate change action plan.

---

## References

- Amakali S (2019) Effects of green manure cover crops on weed population, pearl millet and maize productivity under conservation agriculture in Liselo and Mashare Namibia. MSc thesis, University of Namibia
- Anderson P, Currie B, Louw DC, Anderson DM, Fernández-Tejedor M, McMahon T, Rangel I, Ellitson P, Torres O (2004) Feasibility study for cost-effective monitoring in Namibia and Angola with an analysis of the various options for implementation of Shellfish Safety Programs. Final Report. BCLME project EV HAB/02/02a: Development of an Operational Capacity for Monitoring of Harmful Algal Blooms in Countries Bordering the Northern part of the Benguela Current Large Marine Ecosystem Phase 1 –Design
- Bidartondo MI, Ellis C, Kausserud H, Kennedy PG, Lilleskov EA, Suz LM, Andrew C (2018) Climate change: fungal responses and effects. In: Willis KJ (ed) State of the world's fungi. Report. Royal Botanic Gardens, Kew, pp 62–69
- Branch TA, DeJoseph BM, Ray LJ, Wagner CA (2013) Review – impacts of ocean acidification on marine seafood. *Trends Ecol Evol* 28(3):178–186
- Christelis G, Struckmeier WF (2011) Groundwater in Namibia. In Water
- Chung CE, Ramanathan V, Kim D, Podgorny IA (2005) Global anthropogenic aerosol direct forcing derived from satellite and ground-based observations. *J Geophys Res* 110:D24207. <https://doi.org/10.1029/2005JD006356>
- Compain P (2012) Solar Energy for Water desalination 46(0):220–227. <https://doi.org/10.1016/j.proeng.2012.09.468>

- COW (2019) Water management plan. City of Windhoek, Windhoek
- Darre NC, Toor GS (2018) Desalination of water: a review desalination of water: a review. March. <https://doi.org/10.1007/s40726-018-0085-9>
- Doney SC (2006) The dangers of ocean acidification. *Sci Am* 294(3):58–65
- FAO (2005) Namibia Aquastat Survey. 1–14. [http://www.fao.org/nr/water/aquastat/countries\\_regions/NAM/NAM-CP\\_eng.pdf](http://www.fao.org/nr/water/aquastat/countries_regions/NAM/NAM-CP_eng.pdf)
- FAO/WHO (1999) Codex Alimentarius commission approves guidelines for organic food. <http://www.fao.org/organicag/oa-faq/oa-faq1/en/>. Accessed 23 June 2020
- Fletcher IA (2019) Effect of temperature and growth media on mycelium growth of *Pleurotus ostreatus* and *Ganoderma lucidum* Strains. *Cohesive J Microbiol Infect Dis* 2(5). ISSN 2578-0190. <https://doi.org/10.31031/CJMI.2019.02.000549>
- Formenti P, John Piketh S, Namwoonde A, Klopper D, Burger R, Cazaunau M et al (2018) Three years of measurements of light-absorbing aerosols over coastal Namibia: seasonality, origin, and transport. *Atmos Chem Phys* 18(23). <https://doi.org/10.5194/acp-18-17003-2018>
- Formenti P, D'Anna B, Flamant C, Mallet M, Piketh SJ, Schepanski K, ... Holben B (2019) The aerosols, radiation and clouds in southern Africa field campaign in Namibia overview, illustrative observations, and way forward. *Bull Am Meteorol Soc*, 100(7):1277–1298. <https://doi.org/10.1175/BAMS-D-17-0278.1>
- Hausiku MK, Mupambwa HA (2018) Seaweed amended rice straw substrate and its influence on health related nutrients, trace elements, growth and yield of edible white elm mushroom (*Hypsizygus ulmarius*). *Int J Agric Biol* 20:2763–2769
- Heintzenberg J (1985) What can we learn from aerosol measurements at baseline stations? *J Atmos Chem* 3(1):153–169. <https://doi.org/10.1007/BF00049374>
- Lahnsteiner J, Lempert G (2007) Water management in Windhoek, Namibia. *Water Sci Technol* 55 (1–2):441–448. <https://doi.org/10.2166/wst.2007.022>
- Leistner OA (1967) The plant ecology of the southern Kalahari, Republic of South Africa. *Bot Res Inst Bot Surv Mem* 38:1–172
- Lubinda M (2015) Factsheet on climate change: the definition, causes, effects and responses in Namibia. <https://www.thinknamibia.org.na/files/learn-and-engage/TlaQWEcwS5WDIWme.pdf>. Accessed 22 June 2020
- Mapaure I (2011) Climate change in Namibia: projected trends and effects. In: Ruppel OC, Ruppel-Schlichting K (eds) *Environmental Law and Policy in Namibia*. Hans Seidel Foundation, Windhoek, pp 291–309
- MET (Ministry of Environment and Tourism) (2011) National policy on climate change for Namibia. Government of the Republic of Namibia, Windhoek
- Michou T (2017) Water and greenhouse gases: the desalination challenge
- Ministry of Agriculture Water and Forestry (MAWF) (2015) Namibia agriculture policy. Ministry of Agriculture Water and Forestry, Windhoek
- Mowa E (2015) Organic manure for vegetable production under hydroponic conditions in arid Namibia. *Int Sci Technol J Namibia* 5:3–12
- Mowa E, Akundabweni L, Chimwamurombe P, Oku E, Mupambwa HA (2017) The influence of organic manure formulated from goat manure on growth and yield of tomato (*Lycopersicon esculentum*). *Afr J Agric Res* 12(41):3061–3067. <https://doi.org/10.5897/AJAR2017.12657>
- Mshigeni KE (2001) The cost of scientific and technological ignorance with special reference to Africa's rich biodiversity. University of Namibia, Windhoek. <https://doi.org/10.4314/dai.v13i3.15605>
- Mupambwa HA, Mnkeni PNS (2018) Optimizing the vermicomposting of organic waste amended with inorganic materials for production of nutrient-rich organic fertilizers: a review. *Environ Sci Pollut R* 25:10577–10595
- Mupambwa HA, Ravindran B, Dube E, Lukashe NS, Katakula AAN, Mnkeni PNS (2020) Some perspectives on Vermicompost utilization in organic agriculture. In: Bhat SA, Vig AP, Li F, Ravindran B (eds) *Earthworm assisted remediation of effluents and wastes*. Springer, Japan, pp 299–331

- Norton JM (2011) Ocean acidification: cause, effect, and potential mitigation approaches. *A Journal of Academic Writing*, Hohonu, p 9
- OLRAC (2009) Specialist study: marine ecology impact assessment. Environmental impact assessment for the proposed expansion of the container terminal at the port of Walvis Bay. Prepared by OLRAC (Ocean and land resource assessment consultants) for CSIR Stellenbosch
- Petrick W, Müller S (2019) Erongo desalination plant environmental management plan, Swakopmund
- Pollard RT, Salter I, Sanders RJ, Lucas MI, Moore MC, Mills RA, Statham PJ, Allen JT, Baker AR, Bakker DCE, Charette MA, Fielding S, Fones GR, French M, Hickman AE, Holland RJ, Hughes Aj, Jickells TD, Lampitt RS, Morris PJ, Nedelec FH, Nielsdottir M, Planquette H, Popova EE, Poulton AJ, Read JF, Seevave S, Smith T, Stinchcombe M, Taylor S, Thomalla S, Venables HJ, Williamson R, Zubkov MV (2009) Southern Ocean deep-water carbon export enhanced by natural iron fertilization. *Nature* 457:577–580
- Pryor AM, Blanco B, Galtes J (2009) Desalination and energy efficiency for a uranium mine in Namibia. *Ground Water*:1–16
- Ramadan E (2015) Sustainable water resources management in arid environment: the case of Arabian Gulf. *Int J Waste Resour* 05(03):3–6. <https://doi.org/10.4172/2252-5211.1000179>
- Reeta M, Dev MY (2019) Performance of oyster mushroom through use of different agro Byproducts. *J Community Mobilization Sustain Dev* 14(1):174–178
- Reid H, Sahlen L, Stage J, Macgregor J (2008) Climate change impacts on Namibia's natural resources and economy. *Clim Pol* 8:452–466
- Sato H, Morimoto S, Hattori T (2012) A thirty-year survey reveals that ecosystem function of fungi predicts phenology of mushroom fruiting. *PloS one* 7(11):e49777. <https://doi.org/10.1371/journal.pone.0049777>
- Shahtahmasebi SH, Pourianfar HR, Mahdizadeh V, Shahzadeh Fazeli SA, Amoozegar MA, Nasr SH, Zabihi SS, Rezaei SH, Malekzadeh KH, Janpoor J (2018) A preliminary study on domestication of wild-growing medicinal mushrooms collected from Northern Iran. *Journal of Fungal Biology* 8(6):606–623
- Sweet J, Burke A (2006) Country pasture/forage resource profiles Namibia. In: FAO. Namibia climate-smart agriculture program. Food and Agriculture Organization of the United Nations (FAO), Windhoek, pp 2015–2025
- Takeo H, Shoko K, Koichi S, Yuhi S, Yuko O, Shigeki W, Taiki A, Shun H, Takashi M, Masao I, Shu S, Daisuke S, Hiroko E, Tsuyoshi N, Isao I (2012) Effect of ocean acidification on coastal phytoplankton composition and accompanying organic nitrogen production. *J Oceanogr* 68:183–194
- Tal A (2018) Addressing desalination's carbon footprint: the Israeli experience. *Water (Switzerland)* 10(2). <https://doi.org/10.3390/w10020197>
- Trappe JM, Kovács GM, Claridge AW (2010) Validation of the new combination *Mattiolomyces austroafricanus*. *Mycol Progr* 9:145. <https://doi.org/10.1007/s11557-009-0631-3>
- Villafañe VE, Valiñas MS, Cabrerizo MJ, Helbling EW (2015) Physio-ecological responses of Patagonian coastal marine phytoplankton in a scenario of global change: role of acidification, nutrients and solar UVR. *J Mar Chem* 177:–411
- Wahab HA, Manap MZIA, Ismail AE, Pauline O, Ismon M, Zainulabidin MH, Mat Noor F, Mohamad Z (2019) Investigation of temperature and humidity control system for mushroom house. *Int J Integrated Eng* 11(6):27–37
- Waldron HN, Monteiro PMS, Swart NC (2009) Carbon export and sequestration in the southern Benguela upwelling system: lower and upper estimates. *Ocean Sci* 5:711–718
- Watanabe Y, Itanna F, Izumi Y, Awala SK, Fujioka Y, Tsuchiya K, Iijima M (2019) Cattle manure and intercropping effects on soil properties and growth and yield of pearl millet and cowpea in Namibia. *J Crop Improv* 33(3):395–409
- Wei L, Wang Q, Wu H, Ji C, Zhao J (2014) Proteomic and Metabolomic responses of pacific oyster *Crassostrea gigas* to elevate pCO<sub>2</sub> exposure. *J Proteome* 112:83–94
- WHO (2009) Potassium in drinking-water. Background document for preparation of WHO. Guidelines for drinking-water quality. Geneva: World Health Organization (WHO/HSE//09.01/7)

- Wilhelm M (2012) The impact of climate change in Namibia- a case study of Omusati region. Ounongo Repository:1–101. <http://ir.nust.na/handle/10628/381>
- Zimmermann I, Matzopoulos R, Kwaambwa HM (2017) Options to improve soil fertility with national resources. *Namibian J Environ* 1(B):7–15

**Open Access** This chapter is licensed under the terms of the Creative Commons Attribution 4.0 International License (<http://creativecommons.org/licenses/by/4.0/>), which permits use, sharing, adaptation, distribution and reproduction in any medium or format, as long as you give appropriate credit to the original author(s) and the source, provide a link to the Creative Commons license and indicate if changes were made.

The images or other third party material in this chapter are included in the chapter's Creative Commons license, unless indicated otherwise in a credit line to the material. If material is not included in the chapter's Creative Commons license and your intended use is not permitted by statutory regulation or exceeds the permitted use, you will need to obtain permission directly from the copyright holder.





# Social Vulnerability of Rural Dwellers to Climate Variability: Akwa Ibom State, Nigeria

# 110

Jemimah Timothy Ekanem and Idongesit Michael Umoh

## Contents

Introduction .....	2270
Rural Population Characterization in Akwa Ibom State .....	2273
Social Vulnerability of Rural Dwellers to Climate Variation in Akwa Ibom State .....	2275
Factors Affecting Social Vulnerability to Climate Variation .....	2281
Empirically Defining the Underlying Dimensions of Factors Affecting Social Vulnerability .....	2282
Local Support Factor .....	2282
Educational Challenge Factor .....	2283
Income /Employment/Replacement Ability Factor .....	2283
Family Structure Factor .....	2283
Demographic Explosion Factor .....	2283
Age of Resident Factor .....	2284
Gender Inequality Factor .....	2284
Tribal Issues, Public Assault and Insecurity Factor .....	2284
Infrastructure Inaccessibility Factor .....	2285
Loss of Properties/ Accommodation Factor .....	2285
Mobility Factor .....	2285
Disability Factor .....	2285
Weak Local Institution Factor .....	2286
Cultural Constraints Factor .....	2286
Climate Information/ Communication Factor .....	2286

This chapter was previously published non-open access with exclusive rights reserved by the Publisher. It has been changed retrospectively to open access under a CC BY 4.0 license and the copyright holder is “The Author(s)”. For further details, please see the license information at the end of the chapter.

J. T. Ekanem (✉)

Department of Agricultural Economics and Extension, Faculty of Agriculture, Akwa Ibom State University, Uyo, Nigeria

e-mail: [jemimahekanem@aksu.edu.ng](mailto:jemimahekanem@aksu.edu.ng)

I. M. Umoh

Agricultural Science Education Unit, Department of Science, Redemption Academy, Uyo, Nigeria

© The Author(s) 2021

2269

W. Leal Filho et al. (eds.), *African Handbook of Climate Change Adaptation*, [https://doi.org/10.1007/978-3-030-45106-6\\_232](https://doi.org/10.1007/978-3-030-45106-6_232)



Loosed Social Network and Safety Net Factor .....	2286
Environmental / Social Discrimination Factor .....	2287
Measures to Reduce Rural Residents' Social Vulnerability to Climate Change ...	2287
Conclusion .....	2288
Recommendation .....	2288
References .....	2289

## Abstract

For their livelihood activities, rural farming communities depend more on extractive capital. Their capacity to cultivate sufficiently for their family maintenance is greatly impeded by the absence of either temperature or rainfall quantity pattern or uniformity. The divergent effects of recent extreme weather events around the world, including within relatively small geographical areas, exemplify the unequal impacts of climate change on populations. Akwa Ibom State has been found vulnerable to extreme weather events, such as flooding, severe storms, and rising sea levels, leading to homelessness, poverty, conflicts, and war for millions of people. All of these have resulted in social disturbances and dislocations among rural populations, especially in coastal communities, making them more vulnerable to climate variability. In the field of social vulnerability in the state, not much has been achieved. This chapter analyzes the vulnerability of the rural population to climate variability; the socio-economic characteristics of the rural population; the index of social vulnerability of rural dwellers to climate variability; social vulnerability factors; and the rural population's social vulnerability mitigation initiatives in Akwa Ibom State, Nigeria. Social science approaches to human vulnerability draw critical attention to the root causes and factors why people are forced to respond to risks from climate change. A complex social approach to vulnerability is most likely to enhance mitigation and adaptation preparation efforts, given that vulnerability is a multidimensional mechanism rather than an invariable state.

## Introduction

Reading through Gallent and Scott's (2017) observations on rural development planning, it gives a great deal of concern and experience that rural planning has been reduced to the least topic of planning theory and practice in more than five decades. A topical issue of rural development planning in the developing countries of the world should be the improvement of the economy at the rural governance level, given that the area is abundantly endowed with human and natural resources. The vast majority of the population still resides in rural areas and depends on the area for food as well as the supply of basic industrial raw materials, regardless of the increased rural-urban migration rate in many developing countries, including Nigeria (UN 2018).

A 2018 United Nations report showed that a quarter of the population in the countries of the Organization for Economic Co-operation and Development (OECD) is mainly rural, while the rural population is 46% worldwide. Critically, the rural economy is characterized by its own people, cultural characteristics, the uniqueness

of the natural resource base, social and political institutions, and a combination of rural life which promotes national development. Eighty percent of the population in Nigeria lives in rural areas and their livelihoods are essentially linked to the rural economy (Ering et al. 2014). In addition, the rural area is described as having a low population density, small geographical sizes, and relative isolation, where people are relatively homogeneous in their values, norms, customs, and culture (Ebong 2017). Ejue emphasized that Nigeria's rural areas are characterized by poor and dilapidated roads, inadequate health facilities, inadequate and poorly equipped educational facilities, poor social facilities, high levels of poverty, unplanned residential layout, and other bottlenecks that hinder human well-being.

Notwithstanding these negative aspects, Scott et al. (2019) found that the rural area can be a reservoir of potential such as serene environment, quality land mass, rich biodiversity, tourism entertainment sites, and indigenous local knowledge reservoirs. At the rudimentary level, Frank and Hibbard (2017) also noted that rural areas provide the backdrop for a number of critical planning issues, such as the distribution of renewable energy, the management and improvement of biodiversity services, food production and security, as well as the extraction and administration of natural resources.

Rural people live very closely with nature in rural areas and natural resources provide the basis from which their fundamental needs are derived. Most of the population in rural regions, for example, rely on rain to start farming activities. There is a unique ecosystem for every community in the rural area, valued, admired, and protected by the people living there. For their social, spiritual, and economic development, they rely on those resources. However, due to prevailing climate conditions and associated events such as floods, storms, droughts, and landslides, a good number of rural dwellers are dislocated, especially in the coastal regions (Gallent et al. 2017). For example, some households are known to have moved further inland from their original settlements in Akwa Ibom State, a southern Nigerian state, leading to geographical dislocations (Ebong 2017). In coastal regions, displacement and migration of people from and to different settlements has also been linked to either or both the incidence of drought and accelerated sea-level rise (Abaje et al. 2016). Developing countries are projected to have an uneven share of the impact of climate variability, and due to its geography, climate, vegetation, soils, population and settlement, energy demand, and agricultural activities, Nigeria is particularly vulnerable (Abaje et al. 2016).

Via extremes of weather and interannual fluctuations, climate situations influence both natural and social processes. In some rural areas, with drenching down-pour, the capacity of rural households to generate enough to feed themselves is greatly impeded by short rainy seasons (Okpara et al. 2017). These weather patterns influence agricultural production, reduce crop yields, and, in response to the prevailing conditions, enable farmers to change their agricultural practices. In the work of Umoh et al. (2013), it was reported that Akwa Ibom State was vulnerable to adverse impacts of climate variability and change in the Niger Delta region of Nigeria. Considering the widespread poverty, unequal distribution of land, over reliance on rain-fed agriculture, low income, and poor institutional capability, this observation became evident. The State is also vulnerable to extreme

weather events such as flooding, severe storms and rising sea levels, in addition to inter-seasonal and inter-annual climate variations, resulting in loss of food crops, household food shortages, homelessness, poverty, and exacerbating circumstances that would lead millions of people to violence, war, and misery (Umoh et al. 2013). In some communities in Akwa Ibom State, heavy and sustained rainfall beyond the absorption capacity of the soil and the flow capacity of rivers and streams is prevalent, and populated areas adjacent to these rivers and streams are subject to recurring flooding, making the region “flood-prone” and placing the population at risk. All of these contribute to social disruption and dislocation of rural populations, especially in coastal communities, making them more vulnerable to climate change.

There is really no consensus that the exact nature of vulnerability renders it a relative concept that is disputed. The word “vulnerability” is derived from a Latin word meaning to be hurt, “*vulnerare*.” This demonstrates the vulnerability of persons and activities to physical violence and/or psychological harm. The vulnerability of a device, individual, or person to a threat is broadly related to the potential to be harmed by that threat (Calderon and Serven 2014). The Intergovernmental Panel on Climate Change (IPCC) describes vulnerability as “the degree to which a system, including climate instability and extremes, is vulnerable to or incapable of dealing with adverse effects of climate change” (IPCC 2014). Vulnerability can have some effect on physical and socio-economic characteristics that are not static. This implies that vulnerability is unique to those evaluating it in a place, context, time, and perspective. Social scientists and climate scientists also use the word “vulnerability” to mean various things, although social scientists prefer to see vulnerability as reflecting the collection of socio-economic factors that decide the capacity of people to cope with stress or change, allowing groups to differ (Allen 2011; Huynh and Stringer 2018). Climate scientists also view a human system’s vulnerability as determined by the existence of the physical hazards to which it is exposed, the probability of the hazards occurring regularly and the level of human exposure to hazards, as well as the resilience of the systems to the danger impacts (Ruppert and Dedy 2017; Sadri et al. 2017). Vulnerability, therefore, is a combined hazard, exposure, and sensitivity feature (Calderon and Serven 2014).

Most commonly, social vulnerability is described as “the differential ability of groups and individuals to cope with hazards based on their physical and social world roles” (Dow 1992) or as “the inability to take effective loss insurance steps” (Bogard 1989). This also indicates the degree to which the loss, injury, or harm caused by the effects of a climate threat is revealed to a population, physical infrastructure, economic assets, and the general well-being of individuals. Any of these consequences are due to the features of social relationships, organizations and structures, and cultural values. In contrast to the prevailing belief in vulnerability to the impacts of climate variation, which focuses on the physical dimensions, this concept draws more attention to the social dimension of vulnerability. Obviously, social vulnerability focuses on demographic, social, economic, political, and cultural factors that increase the effect of climate hazards on rural inhabitants. In terms of education, gender, income, health status, access to credit and information technology, formal and informal (social) capital,

political power, and so on, people living in a group most often differ; these variables also trigger variations in their levels of vulnerability (Huynh and Stringer 2018).

Unfortunately, the social dimensions of vulnerability to climate hazards are rarely paid attention to in most recorded issues and corresponding measures, thus explaining the reason for the very limited studies on social vulnerability in Nigeria taken either at national or state level. In the disaster literature, social insecurity of people in rural areas is widely overlooked and tends to be the least documented condition, explaining why social losses are most frequently missing in estimates of postdisaster cost/loss assessment (White and Howe 2012; UN 2018). Not being able to assess all aspects of climate-related vulnerability would have a detrimental effect on the adaptability of populations and their resilience to climate-related risks. There has been a strong gap in the actual understanding of how socially vulnerable rural communities in Akwa Ibom State emphasize the need to assess their status as socially vulnerable to climate change, taking into account steps to mitigate social vulnerability in rural communities. In order to fill the void, this research came in.

Therefore, this chapter summarizes the report of a state-run study on the social vulnerability of rural dwellers to climate variability. The study described the rural population in the state as specific targets, identified the social vulnerability index of the rural population in the state, identified factors affecting the social vulnerability of the rural population in the state, and identified initiatives to reduce the social vulnerability of the rural population in the state.

---

## Rural Population Characterization in Akwa Ibom State

Sex, marital status, age, educational qualification, primary occupation, monthly income, household size, form of housing, position of building, and health status were the selected socio-economic characteristics of the respondents considered in the sample. The respondents' sex distribution showed that there were more females in the areas than males. The dominance of women in the fields of study can be attributed to the migration of men to the source of alternative opportunities for urban jobs. It also means that with climate change, more women are likely to be affected because in the study region they outnumbered the men. During rehabilitation, women will have more difficult times than men, due to streamlined jobs, meager salaries, and responsibility for family care. In local and national decision-making, women often lack a voice and a representative and are isolated in political processes, affecting their exposure, sensitivity, and resistance to climate hazards (Mansur et al. 2016; Anderson 2014).

Women account for the greater majority of the world's poor in rural areas. They depend on natural resources for their livelihoods and survival more than men. Women tend to have lower earnings and are more likely than men to be economically dependent. For example, when droughts or unseasonable rains threaten agricultural production, men may use their savings and economic freedom to invest in or otherwise adapt to alternative sources of income (Omi and Winant 2015). But as household shock absorbers during periods of economic and physical deprivation, women extend

their already highly undervalued working hours and may even decrease their nutritional status to increase that of the family (Maldonado et al. 2016).

The majority of respondents were married during the research. The high percentage of married respondents is consistent with Ekanem et al. (2020), who noted that among rural people in Nigeria, getting married is highly valued with the intention of using these women for unpaid family work. The high percentage of “married” marital status appears to impose certain restrictions on most female study respondents because married women are forced to adhere to certain requirements imposed by their husbands directly or indirectly by tradition. Men’s dominant efforts make women feel inferior and unable to take part in life-affecting events. For example, a female respondent said, “When disaster occurs, without the consent of our husbands, we cannot move.”

In the research area, the study found a certain percentage of widowed respondents. This may be attributed to a high mortality rate among men drowning in the high seas during an expedition to fish in the coastal parts of the state. During the analysis, the percentage of the separated according to the extracts from the FGD groups is due to the loss of housing during the flood time that makes couples absolutely powerless as they have to transfer to nonaffected areas. One of the women had to say, “Our husbands migrate from rural areas to cities to exploit perceived economic opportunities in the course of economic deprivation as migrants and indirectly dumb us at home to take care of children, elderly or sick family members and often remarry other women outside our culture.”

The bulk of the respondents were between the ages of 61–80. Because of their health problems, those respondents who were within the age range of 60–80 years were considered to be economically inactive, rendering them unable to embrace new information or to engage in adaptation preparation in order to minimize their degree of social vulnerability to climate change. The educational level of rural residents can restrict their ability to understand and respond to climate information. The findings of our study showed that the majority of respondents (64.7%) did not have formal education, 23.7% had primary education, 11.0% had secondary education, while just 0.67% of respondents read up to tertiary level. This means that the majority (64.7%) of respondents would be more vulnerable to climate change due to their inability to access, read, and comprehend weather information literature, as posited by Davies et al. (2017), who noted that various climate threat information cannot be accessed or acted upon by the least informed community members in order to plan for recovery.

The majority of respondents had agriculture as their primary occupation, with few others taking on employment in commerce, crafts, and wages. Other occupations, such as boat mending, water transport, motorcycling, etc., constituted 1.7% of the primary occupation of the respondents. The outcome showed that 40.0% of the respondents were artisans engaged in various low-income activities. During catastrophes, this behavior is typically lost and therefore increases their vulnerability and resilience.

Most respondents had a monthly income of N1,000–20,000, with just 1% of respondents receiving a monthly income of N40,001–N60,000. The outcome

indicates that 95% of low-income (1000–20,000) respondents had little to no financial support to mitigate their social vulnerability. Ekanem et al. (2020) and Anderson (2014) expressed the view that households with less access to energy are more economically sensitive to the impacts of immediate and eventual climate variability.

Household sizes are very high for rural dwellers in Akwa Ibom State. Our study found that most respondents had household sizes in the range of 11–15 individuals. Due to frequent flooding that damages residential apartments causing population displacement, it can be deduced that household size increases, which could result in more individuals sharing few habitable apartments. Some respondents, especially the coastal residents, pointed out that “we lost our houses when disaster hits and plead with neighbors to squat us.” The standard of the housing is closely linked to the personal wealth of the respondent. That is why some rural residents live in badly developed houses that are vulnerable to heavy rainstorms and flooding (Hollesen et al. 2018). Our analysis has revealed 79. Nine percent of the respondents lived in thatched roof mud buildings, while 8.3%, 5.7%, and 6.3% of the respondents lived in zinc roof, zinc mud, and zinc cement, respectively. As Cutter et al. (2016) and Kintisch (2016) asserted that rural poor live in substandard and overcrowded houses vulnerable to the spread of diseases and the effect of disasters, the results indicate that respondents are mostly poor. Of necessity, this is a vital element in assessing the vulnerability of climate hazards. In rural areas, the value, quality, and density of residential buildings affect possible losses and recovery.

Observations have shown that, as demonstrated by the 2009 U.S. Hurricanes Katrina, climate threat and its aftermath have a significant effect on people with disabilities. Our analysis found that 19.9% of the participants were people with disabilities. These individuals are likely to be more vulnerable to the consequences of climate variability as “climate change causes increasing distress and reduced opportunities for them to access critical emergency information” (Cutter et al. 2016; Hollesen et al. 2018). The World Report on Disability also reveals that people with disabilities are particularly inclined to be neglected in emergency assistance and relief operations (World Health Organization and World Bank 2011) (Table 1).

---

## **Social Vulnerability of Rural Dwellers to Climate Variation in Akwa Ibom State**

Table 2 indicates many factors that predispose households to the adverse effects of the state’s climate variability. Ten elevated rank variables have been picked. The first three reasons were: dwelling place loss ( $x = 2.38$ ; ranked 1), properties open to criminals ( $x = 2.32$ ; ranked 2), and children’s failure to complete their education ( $x = 2.29$ ; ranked 3). The results suggest that the nature and location of housing makes individuals more vulnerable to risks. In hazard-prone areas, such as flood plains and slums, poor people are more likely to live. This

**Table 1** Distribution of rural dwellers based on their socio-economic characteristics

Item	Selected variables	Frequency n = 300	Percentage (%)
1	<b>Sex</b>		
	Male	142	47.3
	Female	158	52.7
2	<b>Marital status</b>		
	Single	33	11.0
	Married	150	50.0
	Separated	27	9.0
	Widowed	90	30.0
3	<b>Age (years)</b>		
	<1–20	1	0.3
	21–40	3	1.0
	41–60	50	18.7
	60–80	240	80.0
4	<b>Educational status (years of formal schooling)</b>		
	0	194	64.7
	1–4	71	23.7
	5–8	33	11.0
	9–12	2	0.67
5	<b>Primary occupation</b>		
	Farming	66	22.0
	Trading	88	29.3
	Artisan	120	40.0
	Salaried job	21	7.0
	Others (Ukada)	5	1.7
6	<b>Income level (N)</b>		
	<1–20,000	289	95.3
	20,001–40,000	9	3.0
	40,001–60,000	4	1.3
	60,001–80,000	1	0.3
7	<b>Household size</b>		
	1–5	27	9.0
	6–10	115	38.3
	11–15	158	52.7
8	<b>Housing type</b>		
	Thatch roof	239	79.7
	Zinc roof	25	8.3
	Mud with zinc	17	6.3
	Cement with zinc	19	6.3
9	<b>Location of building</b>		
	Low lying land	15	5.0
	Flood plain	19	6.3
	Close to seashore	56	18.7
	Upland	210	70.0

(continued)

**Table 1** (continued)

Item	Selected variables	Frequency n = 300	Percentage (%)
<b>10</b>	<b>Health status</b>		
	Not physically challenged	240	80.0
	Hearing/speech impaired	12	4.0
	Visually impaired	19	6.3
	Amputated	8	2.6
	Hypertensive/diabetic patient	21	7.0

corroborates the earlier findings of Birkmann (2013) and Nelson et al. (2016), who recorded that hastily established settlements are more physically vulnerable in terms of subsistence and geographical position to immediate climate impacts. Nelson et al. (2016) further clarified that rural communities have less political voice in disasters such as severe flooding and windstorms, thus raising the likelihood of their residents being physically harmed. Brown (2016) argued that the most vulnerable to climate hazards are likely to be the least trained and low-skilled members of society and that government may pay little attention to their well-being. This implies, as Tall (2019) notes, that vulnerability is reduced by better education and knowledge. Suitable weather knowledge, for example, enables farmers to predict seasonal trends.

Variables in the 4th, 5th, and 6th ranks were loss of privacy ( $x = 2.27$ ), blocked from health facilities ( $x = 2.20$ ), local workshop destruction ( $x = 2.18$ ). During floods, the privacy of people tends to be absolutely threatened, eventually subjecting them to immense social deprivation. The women had this to say in the study area (coastal region); in many cases, due to lack of privacy, we cannot respond to the call of nature. As a consequence, to defecate, we have to wait till night. In the case of pregnant mothers, disabled, and elderly people, the condition is getting worse. The study by Brondizio et al. (2016) and Hollesen et al. (2018) reinforced that during floods, disease outbreaks are prevalent; they submerge latrines and contribute to misery. They not only become victims of snake bites, but also suffer from skin diseases regularly. People in poor health and those who are undernourished will be more vulnerable to the immediate and secondary effects of extreme climate events, according to Hardy et al. (2017), since they are less likely to be able to plan for or cope with the impacts of climate hazards.

The ranked variables placed 7th, 8th, 9th, and 10th were: absence of services ( $x = 2.16$ ), evaluation of relief materials ( $x = 2.15$ ), loss of relatives ( $x = 2.11$ ), and lack of drinking water ( $x = 2.10$ ). These results have reinforced the assertions of Gamble et al. (2010), who identified the need to take into account the role of human and social capital in assessing climate impact vulnerability. They believed that human and social resources can contribute to the capacity of a society to overcome climate variability through coping and response capacities, whereas a lack of capital can leave individuals isolated and at higher risk of impacts such as severe heat waves being revealed.



**Table 2** Social vulnerability of rural dwellers to climate variability

S/N	Statements	SD	D	A	SA	Mean	Rank
1	We hardly see our relatives as they have been dislocated because of constant flood	33(11.0)	72(24.0)	103(34.3)	92 (30.7)	2.1	9
2	Our local workshop has been destroyed by constant flooding	18(6.0)	110(36.7)	111(37.0)	61(20.3)	2.18	6
3	Peoples' houses are pulled down by strong wind in my community	5(1.7)	99(33.0)	108(3.0)	88(29.3)	1.90	15
4	There is no safe drinking waters in my community as a result of flood	44(14.7)	48(38(12.7)	113(37 3)	95(31.7)	2.10	10
5	People lost their homes due to severe storm	5(1.7)	38(12.7)	94(31.3)	163(54.3)	2.38	1
6	Our food crop is lost because of rise in water level	6(2.7)	49(16.3)	128(42.0)	117(39.0)	1.72	19
7	Our children cannot complete their education because school facilities are flooded	16(5.3)	30(10.0)	105(35.0)	149(49.7)	2.29	3
8	People are attack with different diseases such as skin infection, malaria, typhoid, and dysentery because of continuous inflow of water	70(23.3)	32(10.7)	69(23.0)	129(43.0)	1.86	16

(continued)

**Table 2** (continued)

S/N	Statements	SD	D	A	SA	Mean	Rank
9	Our community is blocked from healthcare services because of increase in water level	10(3.3)	41(13.7)	128(42.7)	121(40.3)	2.20	5
10	We cannot attend ceremonies like wedding child dedication in nearby communities due to high level of water	77(25.7)	32(10.7)	66(22.0)	125(41.7)	1.80	17
11	Our properties are open to thieves because of lack of accommodation	85(28.3)	29(9.7)	55(18.3)	131(43.7)	2.32	2
12	We do not have privacy where we are squatting	52(17.3)	97(32.3)	48(16.0)	154(51.3)	2.27	4
13	Our traditional food and dialect are disappearing as we move to new communities.	21(7.0)	30(10.0)	44(14.7)	112(37.3)	1.79	18
14	Our children get involve in hard jobs to contribute to family's income	31(10.3)	113(37.7)	36(12.0)	171(57.0)	2.03	11
15	People with disabilities have lost assistance and care from relatives as flood disrupt their dwelling places	29(9.)	64(21.3)	69(23.0)	155(51.7)	2.18	6

(continued)

**Table 2** (continued)

S/N	Statements	SD	D	A	SA	Mean	Rank
16	There is reduction in our livestock production as floods pull down farmsteads	25(8.3)	51(17.0)	89(29.0)	136(45.3)	1.71	20
17	We cannot recover our lost properties	28(9.3)	47(15.7)	111(37.0)	98(32.7)	1.93	14
18	We lack facilities to reach out to our customers to sell our farm produce	29(9.7)	62(20.7)	122(40.0)	106(35.3)	2.16	7
19	We are cut off from neighboring community	26(8.7)	46(15.3)	109(36.0)	124(41.3)	1.99	13
20	We cannot assess relief materials in my community	26(8.7)	41(13.7)	99(33.0)	120(40.0)	2.15	8
21	There is scarcity of hired or paid labor in our community due to migration	36(12.0)	45(15.0)	66(22.0)	155(51.7)	2.01	12
22	Our traditional rulers do not inform government about our situation	31(10.3)	48(16.0)	97(32.3)	103(34.3)	1.67	21

**KEY**

SD = Strongly Disagree

D = Disagree

A = Agree

SA = Strongly Agree

Rural dwellers seem vulnerable because they cannot access the services of their society to cope with climate change shocks and stresses. Hardy et al. (2017) argued that their choices are limited and very difficult for them to think beyond their immediate needs, let alone make adaptation plans, if people do not have secured

access to vital livelihood tools. Climate change disrupts social relationships, undermining family bonds, and social ties with loved ones.

## Factors Affecting Social Vulnerability to Climate Variation

Factor analysis was used to examine and identify the factors affecting social vulnerability to climate variation. Sixty (60) items were initially generated during the instrument construction phase to reflect the objective after which it was subjected to factor analysis using principal component approach. This was done to reduce the number of items to major and sizeable significant number of factors using Eigen value criterion of  $\geq 1$  to select the underlying dimensions of the original 60 items.

The principal components method is an exact mathematical transformation of the original set of variables to a new set, with the later summarizing linear relationships exhibited in the data. The best linear combination of the variables gives the first component or factor of the variables. It means that this factor, more than any other, accounts for most of the variance or relationships observed in the data and hence is the best summary of the original data. The second component is similarly defined as the next best linear combination of the variables that would account for the relationships observed in the data after the effect of the first component or factor has been removed, provided both components are uncorrelated (orthogonal). Subsequent components are similarly defined until all the relationships or variance in the data have been accounted for. The factor can therefore be defined as:

$$F = aWA + bwB \pm \dots kwK \quad (1)$$

where

F<sub>a</sub> = factor a, being the best linear combination of all the variable A-K

aw-kw = are weights attached to variables

A-K = variables A-K

Other factors can be similarly defined, as explained earlier. When the factors are uncorrelated, they are said to be orthogonal and a variable “a” in the original data can be defined as:

$$Z_a = Wa_1F_1 + Wa_2F_2 + \dots + Wa_2F_{2+} \dots + Wa_kF_k \quad (2)$$

where  $Z_a$  = Variable a in standard score format (mean = 0 and variance 1),  $W_{a1}$  to  $W_{ak}$  = Weights (normally called factor loadings) attached to factors, and  $F_1$ — $F_k$  = factors I–K. Formula 2 simply means that in factor analysis employing the principal components methods, a variable is viewed as the sum of weighted factors derived from the data. When the data is initially factored, the concern is more on the

possibility of reducing the data to a smaller composite set of factors. At this stage, the factors may not make any meaning until they are rotated to a final solution.

## Empirically Defining the Underlying Dimensions of Factors Affecting Social Vulnerability

Seventeen (17) composite factors were mutually exclusive on the basis of the result of factor analysis performed and major trends were produced. Table 3 introduces these variables and addresses them below:

### Local Support Factor

Inability to access community services is an important aspect of social insecurity, as it relates to the way rural dwellers are categorized on the basis of their income, according to literature (Birkmann 2012). Factor 1 accounts for 21.7% of variance and this is high. This outcome coincides with Passel's 2005 study that poorer households (low class) are not able to access resources fairly due to social factors (economic and political processes) that are custodians of upper class or wealthier people.

**Table 3** Major dimensions of social vulnerability to climate variability

Factor	Names	Eigen values	% of variance	Cumulative %
1	Lack of local support	12.995	21.658	21.658
2	Knowledge barrier	3.762	6.270	27.928
3	Income/employment/replacement ability	2.581	4.302	32.230
4	Family structure	2.333	3.888	36.118
5	Demographic explosion	2.129	3.548	39.667
6	Age of residents	1.851	3.085	42.751
7	Gender inequality	1.710	2.849	45.601
8	Tribal issue/public assault and insecurity	1.564	2.607	48.208
9	Infrastructure inaccessibility	1.542	2.571	50.779
10	Loss of properties and accommodation	1.494	2.490	53.268
11	Mobility	1.407	2.346	55.614
12	Disability	1.291	2.152	57.766
13	Weak local institution	1.225	2.041	59.808
14	Cultural constraint	1.194	1.991	61.798
15	Poor climate information/communication source	1.173	1.955	63.753
16	Loosed social capital/social safety net	1.070	1.783	65.535
17	Environmental/social discrimination	1.051	1.752	67.287

## **Educational Challenge Factor**

Training is related to socio-economic status and accounts for 6.2% of rural dwellers' heterogeneity. Noneducational achievement in the field of study makes community members vulnerable to climate danger because they lack the opportunity to grasp knowledge on warning and recovery. The outcome of the finding is consistent with Nelson et al. (2016), who stated that during floods, children's schooling is impaired as it is difficult to keep and attend classes under submerged conditions. The school appears to become the "front-line" flood shelter for displaced families anywhere the school building is not submerged. UNICEF (2011) confirms this finding by stating that children are forced out of school when natural disasters interrupt the educational system of the community, including teachers. The absence of experienced teachers and other main school staff is detrimental to the academic success of children.

## **Income /Employment/Replacement Ability Factor**

Floods have a significant effect on the source of livelihoods, paralyze economic activities, deepen disparities in economic status, and access to sufficient food and services in the field of research. This explains the 4.3% difference between rural communities. The result supports Sultana (2017) who reported that when affected by a danger case, local individuals who are in primary extraction activities such as fishing, forestry, crop cultivation, and livestock rearing suffer great losses and are unable to rebuild their settlement.

## **Family Structure Factor**

When tragedy occurs, large family size hinders evacuation and this impact increases social vulnerability. There is less time, resources, and energy for families caring for ill members to invest in activities that could minimize the impacts of external threats, help them recover from dangerous incidents, and be better prepared for them in the future. Sultana (2017) also acknowledges that members of large and dependent families – children under the age of 18, elderly and disabled members – need financial assistance, transportation, and disaster medical treatment, and these affect the resilience to risk recovery. This portion explains the variability of 3.8% among respondents.

## **Demographic Explosion Factor**

Village habitation is adversely impacted by population migration and neighborhood disorder. When the flood effect of the community or household shifts to the non-affected area, there is a population influx leading to an increased risk of disease and sanitation system contamination. This is corroborated by McLeman (2016), who

stressed that high population increases outbreaks of disease due to individual proximity to each other and contamination of human waste water sources. Increasing population density increases vulnerability, particularly where the density is high, according to local respondents. Increased population density limited access to land and exacerbated pressure on natural resources during challenging times, respondents clarified. Indeed, population growth means that growing numbers of people are exposed to the impacts of climate variations and that more people have to share scarce resources (e.g., water and food). This explains the 3.5% difference between rural dwellers.

### **Age of Resident Factor**

Age is strongly associated to social disadvantage and 3.0% of the difference is clarified. There is also a rise in health challenges as individuals grow older, and these are compounded during times of dislocation or loss of livelihood due to climate change. The result confirms Omi and Winant (2015), who reported that due to adverse effects of climate variability such as hearing impairment, cognitive difficulties, rise in blood pressure (hypertension), etc., the elderly population experiences different health problems. This affects their potential for disaster management and recovery. Brondizio et al. (2016) also argued that children cannot protect themselves during a disaster, particularly the youngest age group, because they lack the resources, skills, or life experiences required to cope effectively with the situation.

### **Gender Inequality Factor**

2.8 percent of the observed variance is explained by this factor. Sex is a powerful factor illustrating the susceptibility to impacts related to climate change. Factors such as lack of access to and power over basic resources and lack of entitlements exacerbate the vulnerability of women and weaken their capacity to cope with disaster effects (Sultana 2014). The result is consistent with Brown (2016) which stated that because of their distinct socially constructed positions as mothers and family caregivers, women suffer more from the impact of disaster. Faber (2015) notes that stream dries up during extreme situations, for example, when natural water sources, and women have to travel longer distances daily on foot in search of drinking water. The report shows that pregnant and lactating mothers make up a large proportion of these women. Furthermore, he added that women enumerated their experiences during constant flooding over menstrual hygiene management, especially in the coastal zone, resulting in genital injury, bleeding, infections, and other complications.

### **Tribal Issues, Public Assault and Insecurity Factor**

2.6 percent of the variance among respondents is explained by this factor. Literature indicates that people who lose their homes during floods are absolutely powerless as they travel out to non-affected areas without any source of income. They lose the physical social security they once enjoyed in their native villages in their new

housing as migrants. This, in turn, puts them in different kinds of adverse social circumstances; young girls in constant danger of sexual abuse and attack from the boys and men of that group who take shelter on embankments. Professional gangs are also coerced into prostitution by young women, with offers of work elsewhere (Maldonado et al. 2016). The outcome also agrees with Dunning (2011), who noted that, for example, people who do not speak the language of their host group have trouble understanding and reacting to the warning and evacuation order

### **Infrastructure Inaccessibility Factor**

2.5% of the variance is explained by this factor. The outcome is consistent with Davies et al. (2017), who stressed that social deprivation is increased by inaccessibility to vital infrastructure such as highways, shelter, and telecommunication. He emphasized that poorly maintained local road networks rendered some roads impassable. The other part of the city, including the economy, is cut off and blocked from some areas that would promote income security.

### **Loss of Properties/ Accommodation Factor**

This factor explains 2.4% of the difference in rural populations. The outcome is in line with Brondizio et al. (2016) who highlighted the flood “sweep off” farmland leading to crop and income loss. In particular, thatch houses are said to be damaged in coastal communities by floods in the upland or sea level buildings. He further claimed that, especially for poor households, loss of property is more difficult to replace. Some fishermen describe their bitter experiences during a sea pirate attack fishing trip on the high seas where their boat engines and other instruments are stolen and destroyed.

### **Mobility Factor**

This portion explains the variation among respondents of 2.3%. The outcome of the results agrees with Cutter et al. (2016) who posited that for people who do not have cars, transport out of the evacuation zone is problematic. In coastal regions, the movement of people is distorted by the increase in sea level because canoes made locally cannot be paddled at high sea level, are victims of water-related diseases, and cannot access medical facilities and workers in upland areas leading to trauma of nonpathogenic hypertension and stroke conditions. Brown (2016) claims that when emergency strikes, people with disabilities have mobility restrictions, they have trouble finding safe places.

### **Disability Factor**

This variable explains the difference of 2.2% among rural dwellers. The finding is synonymous with the World Disability Study (2011) that when emergency strikes, people with disabilities are left behind in a deteriorated community and are isolated from their families and friends, leading to crippling suffering on them, and they lack the social networks needed to take advantage of services that would speed up their disaster recovery. Hollesen et al. (2018) reported that disasters and their effects have a significant effect on people with disabilities due to the lack of assistive devices such as wheelchairs, crutches, white canes, or hearing aids.



**Weak Local Institution Factor**

2.0% of the differences among local dwellers are explained by this factor. Poor or corrupt institutions can contribute to ineffective and insufficient responses to disaster situations, slowing requests for government support and not actually delivering help to those most in need. This supports Ejue, who claimed that rural communities are limited by weak leadership and lack of freedom and decision-making power as their voices, needs, and desires are not integrated into government projects and this increases sensitivity for poorer households.

**Cultural Constraints Factor**

This element explains the variance of 1.99%. The result is the same with Ejue, who argued that the lack of traditional wisdom has caused elders to suffer contempt from the younger generation because the wisdom they carry is not as detailed as it used to be. This outcome also agrees with Mansur et al. (2016), who stated that as their ethnic cultural identity suffers from the risks of extinction as a result of climate-related risks, older people become more dissatisfied.

**Climate Information/ Communication Factor**

The lack of available, affordable, and appropriate sources of knowledge leads to social vulnerability. This explains 1.95% of the variance. It was found that respondents rely on their personal weather observation, past experience in their community and local institution due to irregularities, and untimely distribution of advance media information that they caption “false stories” or “fly news.” Their conviction is due to the fact that localities are not subject to weather predictions from radio and NTA stations. This result is consistent with d’Alpoim et al. (2016), which posits that in terms of reliability, timing, and languages, there are shortcomings in the knowledge distribution process. It is important to communicate, obtain, and interpret information about weather forecasts and climate predictions via multiple channels, including interpersonal contact, television, radio, the Internet, and social media (Morss et al. 2017). Before they make decisions, individuals combine data from these different sources (Sadri et al. 2017). Social networks help people access, personalize, and understand the importance of knowledge in a significant way.

**Loosed Social Network and Safety Net Factor**

1.78 percent of the variance is explained by this factor. The study agrees with Cutter et al. (2016) that it is difficult for displaced populations to re-organize and restore their former family connections and relationships. Some respondents share their feelings that floods are hindering social activities such as marriage, commitment to children, and funerals. This condition weakens social capital and loosens social relations with loved ones, causing the respondents to be mentally depressed. Kintisch (2016) argued that the loss of the network and lack of access to social gathering make people feel lonely, especially the elderly. Meanwhile, Davies et al. (2017) assume that if placed in place, the social security net will help prevent

postdisaster starvation and assist affected households and communities to safeguard and restore their properties.

### **Environmental / Social Discrimination Factor**

This element explains the variance of 1.75%. The outcome agrees with Cutter et al. (2016) and McDowell et al. (2016), who observed that a nation's inhabitants do not share the benefits of economic growth equally. Discrimination and social isolation result in this. And in rural areas, this is also true.

### **Measures to Reduce Rural Residents' Social Vulnerability to Climate Change**

Table 3 demonstrates strategies that will reduce the social vulnerability of respondents in the study region to climate change. Ten of the most relevant high-rank indicators were chosen. The first four steps to mitigate social vulnerability to the effects of climate variation were: dam construction ( $x = 3.62$ ; ranked 1), flood storage reservoir construction ( $x = 3.57$ ; ranked 2), dam and bridge construction ( $x = 3.56$ ; ranked 3), and gutter opening ( $x = 3.54$ ; ranked 4). These initiatives agree with Eriksen (2012), who noted that one of the adaptation techniques widely practiced by flood victims is the construction of defensive outlets such as flood storage reservoirs, dams, and water transport channels from the affected areas. Davies et al. (2017) accept that for uprooted communities, the embankment acts as temporary shelter.

The fifth method is working to fill sand bags in groups ( $x = 3.53$ , ranked 5). This agrees with McDowell et al. (2016), who stated that for mutual benefit, societies with denser social support networks have more interaction between community members. Eriksen (2012) believed that societies with higher social and stronger social networks will be better able to cope with threats and their consequences because it is easier to analyze knowledge and other types of social support.

The sixth technique is the fund's payment ( $x = 3.52$ , ranked 6). The results confirm that Huynh and Stringer (2018) emphasized that materials for relief and assistance are especially helpful to those individuals who could not afford to repair damaged properties themselves. The seventh, eighth, ninth, and tenth steps were: environmental law enforcement ( $x = 3.50$ , ranked 7), flood-prone areas should not be developed ( $x = 3.49$ ; ranked 8), weather signal recognition ( $x = 3.47$ ; ranked 9). The result corroborates the view of Omi and Winant (2015), who said that individuals should be prevented from developing areas vulnerable to flooding and that defaulters should be punished. And the use of local dialects ( $x = 3.37$ ; rank 10). The results indicate that the combination of extension agents, radio, and local agencies will be more effective in disseminating local dialect environment information and supporting services in insecure areas for vulnerable people.

The least significant steps were: raising consciousness of income diversification ( $x = 3.34$ ; ranked 11), building a well-equipped hospital ( $x = 3.30$ ; ranked 12), the proportion of local cultivars ( $x = 3.02$  ranked 13), and the lack of equitable access to local services ( $x = 2.96$ ; ranked 14).

---

## Conclusion

It can be inferred from the results obtained that 52% of women were vulnerable to climate change in rural areas of Akwa Ibom State. Most of the respondents were between 60 and 80 years of age. The majority of respondents (64%) did not have formal education and are probably the least educated on climate issues. The most important steps to mitigate flooding from the perspective of the respondents were the construction of embankments, flood storage reservoirs, dams and bridges, and opening of gutters; and these were related to the position of respondent construction. The underlying dimensions affecting social vulnerability were lack of local support, information barrier, jobs, employment and replacement capability, family structure, demographic explosion, resident age factor, gender, tribal problems, public attack, and inaccessibility of infrastructure in the insecurity factor. Others included property and housing damages, mobility, disability, weak local institutions, cultural constraints; inadequate sources of environment knowledge and communication; loosened social networks and social security networks; and social discrimination. Rural residents in Akwa Ibom State were highly vulnerable to the effects of climate change because, as seen in the report, the higher the factors that lead to social vulnerability, the higher the degree of social vulnerability of the respondents.

---

## Recommendation

The following recommendations are made based on the study's results and conclusions:

1. Agricultural extension staff, meteorological offices, and community-based agents should be assisted by policy makers and development partners to raise awareness of climate information forecasting and dissemination through usable and accessible communication methods such as local dialect radio, city critics, drama, newsletters, community workshops/seminars, and educational programs
2. Income diversification is an efficient way to reduce vulnerability by spreading risks. To minimize social vulnerability to extreme flooding and drought, less reliance on natural resources would help. Rural dwellers need to maintain and engage effectively in those value-added economic activities that will reduce food insecurity, increase jobs and income opportunities, and enable individuals to accumulate assets that will enhance their ability to cope with potential shocks without worsening poverty.
3. Adaptive planning is required to minimize the vulnerability of vulnerable coastal roads (ferry routes), low-lying buildings and assets, transport, and market connections and to improve legislation to safeguard hazard-prone areas. Adaptive planning is needed.
4. Local institutions should improve social capital, that is, family ties and friendly connections between members of the group should be revitalized so that individuals can collaborate and team up to resolve the effect and challenges of climate

variations for mutual benefit among themselves. In the meantime, friendly ties with relatives away from home should be established for remittances to act as a cushion when subjected to extreme events and also for the provision of temporary accommodation during displacement.

---

## References

- Abaje IB, Sawa BA, Iguisi EO, Ibrahim AA (2016) Impacts of climate change and adaptation strategies in rural communities of Kaduna State, Nigeria. *Ethiop J Environ Stud Manag* 9(1): 97–108
- Allen R (2011) Vulnerability reduction and the community-based approach. In: Pelling (ed) *Natural disasters and development in a globalising world*. Routledge, London, pp 170–118
- Anderson EN (2014) *Caring for place: Ecology, ideology, and emotion in traditional landscape management*. Walnut Creek, CA: Left Coast Press
- Birkmann J (2012) Vulnerability reduction: a task for the vulnerable people themselves. In Bank off, et al (eds) *Mapping vulnerability: disasters, development and Peter*. Earthscan, Sterling
- Birkmann J (2013) *Measuring vulnerability to natural hazards: towards disaster resilient societies*. United Nations University Press, Bonn
- Bogard WC (1989) Bringing social theory to hazards research: conditions and consequences of the mitigation of environmental hazards. *Sociol Perspect* 31:147–168
- Bronzizio ES, de Lima AC, Schramski S, Adams C (2016) Social and health dimensions of climate change in the Amazon. *Ann Hum Biol* 43:405–414
- Brown K (2016) *Resilience, development and global change*. Routledge, London/New York
- Calderon C, Serven L (2014) *Infrastructure, growth, and inequality: an overview*. World Bank policy research working paper. The World Bank, Washington, DC
- Cutter SL, Ash KD, Emrich CT (2016) Urban– rural differences in disaster resilience. *Ann Am Assoc Geogr* 106:1236–1252
- d’Alpoim Guedes JA, Crabtree SA, Bocinsky RK, Kohler TA (2016) Twenty-first century approaches to ancient problems: climate and society. *Proc Natl Acad Sci* 113(51):14483–14491
- Davies G, Frausin G, Parry L (2017) Are there food deserts in rainforest cities? *Ann Am Assoc Geogr Adv*. <https://doi.org/10.1080/24694452.2016.1271307>
- Dow K (1992) Exploring differences in our common future(s): the meaning of vulnerability to global environmental change. *Geoforum* 23:417–436
- Dunning MC (2011) *Social vulnerability analysis methods for crops planning*. Draft report 10/29/09
- Ebong M (2017) *Mobilisation of resources for rural development in Nigeria*. Wusen Press, Calabar
- Ekanem JT, Nwachukwu I, Umoh IM (2020) Post-harvest Adaptiveness of crop farmers to future climates in the Cross River floodplains, Nigeria. *J Commun Commun Res* 5(1):50
- Eriksen SH (2012) *Responding to global changes vulnerability and management of local agro-ecosystems in Kenya and Tanzania*. University of East Anglia, Norwich
- Ering SO, Otu JE, Archibong EP (2014) *Rural Development Policies in Nigeria: A Critical Appraisal*. *Int J Educ Res* 2(9):307–320
- Faber JW (2015) Superstorm Sandy and the demographics of flood risk in New York City. *Hum Ecol* 43(3):363–378
- Frank KI, Hibbard M (2017) Rural planning in the twenty-first century: context appropriate practices in a connected world. *J Plan Educ Res* 37(3):299–308
- Gallent N, Scott M (eds) (2017) *Rural planning and development*. Routledge, London
- Gallent N, Tewdwr-Jones M, Hamiduddin I (2017) A century of rural planning in England: a story of fragmentation, contestation and integration. *Planum J Urban* 35(2):91–104
- Gamble DW, Campbell D, Allen TL, Barker D, Curtis S, Mcgregor D, Popke J (2010) Climate change, drought, and Jamaican agriculture: Local knowledge and the climate record. *Annals of*

- the Association of American Geographers 100:880–893. <https://doi.org/10.1080/00045608.2010.497122>
- Hardy RD, Milligan RA, Heynen N (2017) Racial coastal formation: the environmental injustice of colorblind adaptation planning for sea-level rise. *Geoforum* 87:62–72
- Hollesen J, Callanan M, Dawson T, Fenger-Nielsen R, Friesen T, Jensen A, . . . Rockman M (2018) Climate change and the deteriorating archaeological and environmental archives of the Arctic. *Antiquity* 92(363):573–586. <https://doi.org/10.15184/aqy.2018.8>
- Huynh LTM, Stringer LC (2018) Multi-scale assessment of social vulnerability to climate change: an empirical study in coastal Vietnam. *Clim Risk Manag* 20(2018):165–180
- IPCC (2014) Summary for policymakers. In: Field CB, Barros VR, Dokken DJ, Mach KJ, Mastrandrea MD, Bilir TE, White LL (eds) *Climate change 2014: impacts, adaptation, and vulnerability. Contribution of working group II to the fifth assessment report of the Intergovernmental Panel on Climate Change*. Cambridge University Press, Cambridge, UK/New York, pp 1–32
- Kintisch E (2016) History is melting. *Hakai Magazine*. Retrieved from <http://bit.ly/1PSoFxb>
- Maldonado J, Lazrus H, Bennett S-K, Chief K, Dhillon CM, Gough B, Whyte KP (2016) The story of rising voices: facilitating collaboration between indigenous and Western ways of knowing. In: Companion M, Chaiken M (eds) *Responses to disasters and climate change: understanding vulnerability, building resilience*. CRC Press/Taylor & Francis Group, Boca Raton, pp 15–26
- Mansur AV, Brondizio ES, Roy S, Hetrick S, Vogt ND, Newton A (2016) An assessment of urban vulnerability in the Amazon Delta and estuary: a multi-criterion index of flood exposure, socioeconomic conditions and infrastructure. *Sustain Sci* 11(4):625–643
- McDowell G, Ford J, Jones J (2016) Community-level climate change vulnerability research: trends, progress, and future directions. *Environ Res Lett* 11(3):33001
- McLeman R (2016) Impacts of population change on vulnerability and the capacity to adapt to climate change and variability: a typology based on lessons from “a hard country”. *Popul Environ* 31:286–316
- Morss R, Demuth J, Lazrus H, Palen L, Barton C, Davis C, . . . Watts J (2017) Hazardous weather prediction and communication in the modern information environment. *Bull Am Meteorol Soc* 98(12):2653–2674
- Nelson MC, Ingram SE, Dugmore AJ, Streeter R, Peeples MA, McGovern TH, . . . Smiarowski K (2016) Climate challenges, vulnerabilities, and food security. *Proc Natl Acad Sci* 113(2):298–303
- Okpara UT, Stringer LC, Dougill AJ (2017) A novel climate – water conflict vulnerability index to capture double exposure: application in the Lake Chad Basin. *Reg Environ Chang* 17(2):351–366
- Omi M, Winant H (2015) *Racial formation in the United States*, 3rd edn. Routledge, New York
- Ruppert T, Deady EL (2017) Climate change impacts on law and policy in Florida. In: *Florida’s climate: changes, variations, & impacts*. Florida Climate Institute, Gainesville, pp 209–234
- Sadri AM, Ukusuri SV, Gladwin H (2017) The role of social networks and information sources on hurricane evacuation decision making. *Natural Hazards Review* 18(3):04017005
- Scott M, Gallent N, Gkartzios M (2019) *Planning rural futures*. In: Scott M, Gallent N, Gkartzios M (eds) *The Routledge companion to rural planning*. Routledge, New York
- Sultana F (2014) Gendering climate change: geographical insights. *Prof Geogr* 66(3):372–381
- Sultana F (2017) Gender and water in a changing climate: challenges and opportunities. In: *Water security across the gender divide*, vol 93, 2nd edn. Springer, Cham, pp 17–33
- Tall A (2019) Climate forecasting to serve communities in West Africa. *Procedia Environ Sci* 1:421–431
- Umoh GS, Udo EJ, Solomon VA, Edet GE, Uwem CA, Okoro G, Bassey N, Akpan DO, Atairet E (2013) Adaptation to climate change. In: *Agricultural ecosystems and gender dimensions*. <http://www.xlibrispublishing.co.uk>
- UN (2018) Scoping paper for expert group meeting on climate variation adaptation. African minister conference on the environment 12th meeting of the expert group TBC

- United Nations Children's Fund (UNICEF) (2011) Situational analysis of children and women in Mongolia. UNICEF, Ukanbaatar
- White I, Howe J (2012) Exploring the social impacts of flood risk and flooding in Scotland. Research findings no 32. Scottish Executive Social Research, Edinburgh
- World Health Organization & World Bank (2011) World report on disability. Geneva, Switzerland: World Health Organization

**Open Access** This chapter is licensed under the terms of the Creative Commons Attribution 4.0 International License (<http://creativecommons.org/licenses/by/4.0/>), which permits use, sharing, adaptation, distribution and reproduction in any medium or format, as long as you give appropriate credit to the original author(s) and the source, provide a link to the Creative Commons license and indicate if changes were made.

The images or other third party material in this chapter are included in the chapter's Creative Commons license, unless indicated otherwise in a credit line to the material. If material is not included in the chapter's Creative Commons license and your intended use is not permitted by statutory regulation or exceeds the permitted use, you will need to obtain permission directly from the copyright holder.





# Menace and Mitigation of Health and Environmental Hazards of Charcoal Production in Nigeria

111

Philip Olanrewaju Eniola

## Contents

Introduction .....	2294
Definitions of Climate Change Adaptation .....	2294
Importance of Charcoal Production in Nigeria .....	2295
Factors Responsible for the Production and Utilization of Charcoal .....	2297
Effects of Charcoal Production on Agriculture .....	2298
Health Implications of Charcoal Production .....	2298
Effects of Charcoal Production on the Environment .....	2298
Policy on Charcoal Production-Induced Environmental Problems in Nigeria .....	2300
Problems with Policies and Practice of the 2006 Federal Ministry of Environment in Nigeria which Warranted for Its Improvement by the Federal Parliament in 2019 .....	2301
Factors that Make It Difficult to Plan for Alternative Environmentally Friendly Energy in Nigeria .....	2302
Strategies to Review the Existing Forest Policy on the Provision of an Enabling Environment for Sustainable Forestry Management and Development in Nigeria .....	2303
Climate Change–Charcoal Chain Sector: The Policy Options .....	2304
Panacea for Greening Charcoal Value Chain .....	2305
Agricultural Adaptation Strategies to Climate Change that Can Reduce Charcoal Production .....	2306
Conclusion and Recommendations .....	2307
References .....	2308

This chapter was previously published non-open access with exclusive rights reserved by the Publisher. It has been changed retrospectively to open access under a CC BY 4.0 license and the copyright holder is “The Author(s)”. For further details, please see the license information at the end of the chapter.

P. O. Eniola (✉)

Department of Agricultural Technology, The Oke-Ogun Polytechnic, Saki, Oyo State, Nigeria

© The Author(s) 2021

2293

W. Leal Filho et al. (eds.), *African Handbook of Climate Change Adaptation*,  
[https://doi.org/10.1007/978-3-030-45106-6\\_238](https://doi.org/10.1007/978-3-030-45106-6_238)

---

**Abstract**

The use of biomass and biofuels, such as wood, charcoal, petroleum, kerosene, and gas, is becoming competitive based on the level of development of each nation. However, charcoal production (CP) and marketing now tends to be a major business among many households in both rural and urban communities with no consideration of its effects on climate change adaptation. While the research question considers the various definition of climate change adaptation, and the importance of charcoal production in Nigeria, the manuscript speaks mainly of the problems of charcoal production, the lack of planning to address these problems, and the lack of planning to move the communities away from this practice and out of poverty. It addresses the impacts of charcoal production on agriculture, such as lack or loss of labor and destruction of arable lands. The paper discusses the effect of charcoal production on health. Also, the environmental problems of CP are highlighted in the manuscript. The policy frameworks on forestry by the Federal Ministry of Environment 2006 with its flaws will be included. Remedy such as the establishment of a Land Use Planning Agency (LUPAG) and panacea for greening the charcoal value chain issues will be discussed. Lastly, attention is given to the agricultural adaptation strategies to climate change which are capable of reducing charcoal production, such as mixed cropping.

---

**Keywords**

Climate adaptation change · Poverty · Deforestation · Policy framework · Alternative to charcoal utilization

---

**Introduction****Definitions of Climate Change Adaptation**

Climate change adaptation refers to the process of modification of the present and future impacts of climate change (United Nations Climate Change 2020). Due to the rapidly changing climate, coupled with economic, social, and technological developments, nations have no option but to look for a way to achieve a greater stride which further creates more tension in the ozone layer. According to the Victorian Centre for Climate Change Adaptation Research (VCCCAR) (2020), several views are expressed by scholars as follows: adaptation to climate change is the initiative to enable people and their surroundings to withstand the changing climate conditions (United Nations Framework Convention on Climate Change (UNFCCC) (2015). The Intergovernmental Panel on Climate Change (IPCC) refers to climate change adaptation as tampering with the natural or human systems so as to respond to actual or expected climatic stimuli or their effects. However, the UN Development programs defines it as the process through which strategies to moderate, and withstand



with the subsequent effects of climatic events that are developed, implemented and improved upon. Conversely, the UK Climate Impacts Program defines it as the outcome of a process that creates limitation to the distortion or risk of problem or actualization of benefits that are related to climate variability. But the National Climate change Adaptation Research and Facility (NCCARF) views climate change adaptation as a composition of actions undertaken to reduce the negative effects of climate change, exploiting any beneficial opportunities. Lastly, the Victorian Government states that it is a conscious step to prevent, manage, or decrease the effects of a warmer, drier, and more extreme climate and to maximize the benefits which such changes are likely to provide.

### **Importance of Charcoal Production in Nigeria**

Nigeria is a country that is endowed with crude oil, natural gas, and energy resources, such as solar, wind, biomass, and biogas. The country is gifted with human resources with a total population of 140 million according to the 2006 population census. The annual population growth of Nigeria is about 2.8% (National Population Commission [NPC] 2006). Currently, the national energy supply is almost entirely dependent on fossil fuels and wood fuel (The World Forest Movement 2006). For instance, the value of the charcoal market for 26 sub-Saharan African countries is said to purportedly exceed \$1.8 billion per year (Food and Agriculture Organization [FAO] 2018). In terms of energy, charcoal consumption in many African countries is higher than the quantity of electricity consumed. The importance of charcoal lies in the following areas.

It is a source of considerable amount of employment in rural areas (Arnold et al. 2006). A significant number of rural dwellers relies on charcoal production as a good source of employment, especially in a devastating economy like that of Nigeria. Money realized from charcoal represents per capita income of between 24 and 14 dollars in 1990 and 2000, respectively, which are equivalent to between 1.8 and 4.8 times of per capita income from the sale of agricultural produce in the same years. Charcoal producers reveal that the average annual production in some countries is 160 bags per producer, whereas some produce significantly more than 500 bags. Also, income from charcoal is expended on food, farm inputs, and implements (FAO 2018).

Charcoal production is also one of the recognized economic drivers in some African countries aside from agriculture. However, it generates more income for the rural dwellers (Williams 1993). It also allows for quick return on investments (Stefan 2009). About 65% of the people in the rural areas have made wood fuel and charcoal production a source of income (Shackleton et al. 2006) because of its quick return on investments, unlike the involvement in arable crop production that will bring income in 3 months. In addition to its export value, charcoal trade at the local level provides income opportunities to pay education, health, feeding, and ceremony bills for most rural and urban dwellers through small-scale retail and wholesale (FAO 2018, Fig. 1). It is a reliable, comfortable, and easy form of energy for heating and cooking, with a relatively cheaper cost (Iloeje 2002).



**Fig. 1** Plate showing charcoal depot in Saki derived Savannah zone of Nigeria from field study on April 19, 2013

Charcoal is produced for the poor in rural and urban areas to enable them to meet their energy needs, such as for heating and cooking. It is the most recognized commercial fuel derived from wood. It is smoke-free and can be used in small quantities during cooking (Adam 2009). Charcoal can also produce greater heat than wood, and it is useful for many industries in urban environments. In most developing countries, it is the chief form in which wood fuel is used in towns NL Agency (2010). Charcoal can be stored, takes up little space than firewood for heat generation, and does not deteriorate so easily. It is easier to handle during transportation and distribution. Therefore, it is more preferable to wood (World Bank 2004).

Furthermore, charcoal is used in African art to design various objects (World Energy Council 2004). Charcoal is the raw material for the manufacture of gunpowder and industrial and automotive fuel and for purification/filtration of the cottage industries, the main reason why several individuals continue to produce charcoal. It is also used by blacksmiths and for other industrial applications (Chris 2007). Various uses of charcoal greatly influence the standard of living of rural people who do not have access to agricultural inputs and finances. Charcoal has a higher energy density compared with biomass fuels, and it can be stored without fear of being destroyed by insects (Seidel 2008).

Charcoal is a cheap source of energy for both rural and urban dwellers. However, modern economic activities depend mainly on petroleum products and electricity (FAO 2018). The difficulty associated with the production and use of charcoal, the growing urbanization, and the choice of urban dwellers is at a heavy drain on local wood resources (Arnold 2001).

## **Factors Responsible for the Production and Utilization of Charcoal**

The factors that affect the production and utilization of charcoal in Nigeria.

Poverty are discussed as follows. The increase in the poverty level among Nigerians causes drives the production and use of charcoal. Although it is very essential for all the rural dwellers to use improved energy for cooking and heating, they lack the financial wherewithal to purchase kerosene, which is an alternative. They rely mainly on charcoal, which is cheap and available but has serious environmental hazards. Long gestation period of agricultural products in contrast to charcoal production that takes a lesser period of two or three weeks. Thus, rural dwellers prefer to use it as an alternative source of income to other agriculture income generating activities.

The lack of employment may encourage the mass movement of rural dwellers into charcoal production. The absence of job opportunities, especially paid ones, induces rural dwellers to participate in charcoal production as an alternative source of employment. The current economic recession in the country has made it possible to lay off both rank and file staffs in our various industries. Also, urban rehabilitation is forcing most motorcycle riders to relocate to the rural areas. This makes charcoal production an alternative source of employment.

The lack of awareness on the environmental effects of charcoal production is a serious issue. Most rural dwellers are not aware of the negative effects of charcoal production on their environment which, in turn, results in climate change. Poverty and level of education, among others, also influence awareness of the negative effects of charcoal production on the environment. Since the focus of every rural dweller is to obtain a means for survival, they are not concerned about the implications of their action.

Insufficiency of basic amenities in rural areas may trigger charcoal production. Rural dwellers usually depend on the government for their basic human needs, such as electricity, cooking gas, and the likes, in their domain. The inability of the government to provide such basic amenities triggers high production and consumption of charcoal as a perceived good source of energy for cooking and heating. Thus, the quantity of wood charcoal production in Nigeria stands at 4022763 tonnes per annum (World Bank 2011).

The lack of proper implementation and enforcement “by successive government” may affect our environment. There are good policies that have been established on forestry and allied matters in Nigeria. It is unfortunate that the change in government and loss of focus often inhibit their effective implementation. Sometimes, evaluation units to ensure strict implementation are absent. The focus of successive government always differs from one to another. However, irrespective of their different interests, every government is expected to focus on the mitigation process of climate change adaptation.

Industrial revolution: Before the discovery of oil in Nigeria, agriculture was the main occupation of about 70% of the Nigerian population, with most farmers having less than 1 ha of farming land. With the advent of industrialization, lands are cleared constantly. Thus, trees are cut down and used to produce charcoal.

The high cost of farming input can also increase the number of charcoal producers. Some rural dwellers lack the purchasing power for farm implements. As a result, they see charcoal production as a cheap means of fending for themselves when the cost of farming is high.

---

### **Effects of Charcoal Production on Agriculture**

It should be noted that charcoal production has different effects on agriculture, such as lack or loss of labor. When the same labor that is expected to till the land for agricultural activities still cut down trees and makes charcoal kilns, farming activities are hindered, especially when they get quick income. It results in the reduction in the number of people in agriculture. When there are more enabling environments available for charcoal production, charcoal producers feel more comfortable in the business operation, thus decreasing the number of people involved in farming. This act will definitely lead to food shortage in the country. Charcoal production destroys arable lands. When trees are cut for charcoal production, the lands become susceptible to wind and water erosion. These negative practices eventually destroy the structure of the soil and make it infertile for arable crop farming.

---

### **Health Implications of Charcoal Production**

Aside from the effects of charcoal production on the environment, there are also human health-related challenges (UNDP 2005). These include backache, heat, and cough, among other ailments, which are experienced a lot by charcoal producers. Repetitively moving heavy woods during charcoal production induces lumbar pain and muscular soreness to the producers (Tzanakis et al. 2001). It is worth noting that some charcoal producers lose their lives during the production. Accidents may also occur during the cutting of trees, kiln preparation, and loading of charcoal onto lorries. Furthermore, producers inhale gases and smoke, and the heat produced during the charcoal production is a source of ailments, such as respiratory diseases and cough. They also experience sore hands, fatigue, and chest pain. Sputum production, dyspnea, and hemoptysis are other ailments suffered by the producers.

---

### **Effects of Charcoal Production on the Environment**

The major environmental problems caused by charcoal production in Nigeria are discussed as follows. Deforestation is a product of charcoal production which has significant impacts on the environment, especially with regard to increased erosion. It can also worsen climate change and threaten biodiversity. Deforestation is the destruction of forest areas for several purposes, such as agriculture, urbanization, and

wood fuel and charcoal production. Charcoal production requires commercial felling of wood, thus leading to deforestation (Eniola 2014). Greenhouse gas (GHG) emission is a dangerous phenomenon of charcoal production. The reduction of forest cover also minimizes carbon consumption and results in the release of already-fixed carbon. For instance, the effect of charcoal on forest reserves is disastrous on two grounds. First, the wood fuel equivalent is four to six times greater due to the lack of a professional production process (Fig. 2) (SEI 2016). Second, emission of gas during charcoal production is significant compared with charcoal burning. Aside from the above, ecosystem destruction has a long-term negative effect on the environment. Woods are obtained illicitly from land, and charcoal producers are compelled to harvest woods to enable immediate charcoal production (Emedilichi 2018). Charcoal producers may sometimes gather dead woods, twigs, and branches and allow trees to regenerate. Due to the cutting of live trees for charcoal production, some important wood fuel species, such as mahogany and shea tree, which were abundant in the past years, are becoming scarce (Pabi and Morgan 2002). Charcoal production also affects the soil structure in two ways: first, it impacts on the kiln site (soil) where combustion takes place as a result of huge heat that is released from the covering process, and second, it affects the surrounding/environment of the production pit. Ogundele et al. (2011) and Oguntunde et al. (2008) revealed that the soil in the site of charcoal production has a slight increase in pH. It reduces bulk density of soil surface temperature, higher infiltration rate, and surface albedo compare to places that are not subject to charcoal production (Chidumayo and Gumbob 2012).



**Fig. 2** Image of the combustion process during charcoal production in Saki from a field study conducted on April 19, 2013

## **Policy on Charcoal Production-Induced Environmental Problems in Nigeria**

The major objective of the Federal Ministry of Environment on Forestry Policy (2006) is to achieve an acceptable level of self-sufficiency in wood products through the use of sound management methods. Hence, the main thrust of the policy is consolidation and increase in the forest estate and its management for the usage of the future generation. Due to the human-induced environmental problems, which the present forest estate cannot cope with, more forest estate is an area of land covered by different species of trees should be created in the country to prevent future disasters. Forest conservation and environmental protection are important. Our forests are no longer preserved adequately, unlike in the past. Cattle herdsmen can now be seen ravaging our forests, and wood fellers easily enter the forest and destroy the ecosystem. Thus, governments must exert more efforts to conserve our forests.

There is a great contrast between forest exploitation and forest regeneration. There should be a more increased rate of forest generation than forest exploitation to achieve a sustainable environment. There should be proper utilization of both the forests and its products. In addition, research on how non-forest products can take the place of forest products in all human activities, such as building and other energy requirements, need to be conducted. This will make the future generations benefit the forests and their products. Forest estates should be protected from fires, poachers, trespassers, and unauthorized grazers. It should also be noted that hunters, unauthorized grazers, and farmers endanger forest estates by setting them on fire to obtain their daily needs. These devastating habits must be prevented to secure the forests. The establishment of private forestry can significantly improve our forests. Thus, the government should permit and encourage private individuals to establish plantations of gmelina, teak, cashew, shear, and many other economic trees that can help to preserve and protect the environment. Also, the establishment of manmade forests for specific end-uses is a good means to regain the strength of forests. The government should establish a specific type of forest mainly for a particular tree user where they can go to without hindrance. The development of secondary forest products that are important in local economies and that support agro-forestry practices will boost the economy of the nation.

A policy that encourages the establishment of forestry to provide employment opportunities also needs to be implemented. The only thing that can reduce the occurrence of forest encroachment is to create more employment for people. Otherwise, more rural dwellers will rely on the forest and its products. In addition, more national parks and game reserves need to be created, and the existing ones should be properly maintained. An efficient use of wood energy and alternative sources of energy to wood fuel is also required. Lastly, cooperation among the international community with regard to forestry development must be encouraged (Federal Ministry of Environment 2006). Any law, regulations, and agenda in ensuring the sustainable use of the environment introduced by the international community must be strictly adhered to.

## **Problems with Policies and Practice of the 2006 Federal Ministry of Environment in Nigeria which Warranted for Its Improvement by the Federal Parliament in 2019**

There are so many flaws in the 2006 forestry policies which the new one to be assented to by the President of Nigeria is expected to cater for. Among them is the alarming widespread and increasing land and vegetation degradation. The policy failed to prevent indiscriminate destruction of forests and their products. Forest users enter the forests freely and take away useful products and by-products. These nefarious acts result in fast land degradation. Every day, the influence of humans on the forest continues to increase due to the search for means of income. There are escalating real supply and demand deficits for forest products. The demands for forests and their products are greater than the available resources, which is a serious problem for the future generations. In Nigeria, credible databases are lacking, and there are no records of the quantity of woods and other products removed from the forest, of endangered species, and of future woods requirements. Moreover, the ineffective management of forest reserves is not given sufficient attention. The present system allows unauthorized grazers and poachers to enter the reserves freely. This may be due to the lack of adequate personnel, especially at the state level, and equipment to assist them in their duties. Negligible private investment in forestry is recorded in the implementation of the policy. Due to the several bottlenecks in acquiring land titles, private investors become discouraged in investing in forestry. There is abandonment of trees biodiversity that yield a low level of protection of existing reserves. Most of the forest users only prioritize their own needs at the expense of other forest products. And the protection of other forest products is being neglected. Moreover, there is a conflicting management of forests and its resources in the northern part of Nigeria. The states and local governments still compete for the control and utilization of the forest and its resources. This may be due to the fact that the environment is predominantly a grazing zone for cattle rearers.

The Climate and Development Knowledge Network (CDKN) of the UNFCCC (2015) expressed that it is very difficult for the less-developed countries, such as Nigeria, to implement any forestry policies that will give room to tangible climate adaptation strategies due to the following challenges: It is not easy to create awareness on the need and benefits of action among stakeholders, including policy makers. This may be linked to the high level of illiteracy in the country. A serious concern is how to enhance and integrate climate change into national planning and development processes. A budget allocation for climate change adaptation strategies every year can be beneficial. Also, the methods for strengthening the links between different tiers of government plans on climate change may not be easily realizable. This is because both segments of the government may develop different approaches to climate change adaptation without considering the global implications of such actions. Another method is to build capacity, analyze, develop and make use of climate change policy. There is a need for the inclusion of sound researchers in the implementation of climate change policy. How to establish a realistic mandate to

coordinate actions around NDCs and drive their implementation is important to climate change adaptation in Nigeria. The best ways to address resource constraints are to develop and implement climate change policy. Both human and nonhuman resources may be considered as serious constraints, especially where expertise on climate and equipment are needed.

---

### **Factors that Make It Difficult to Plan for Alternative Environmentally Friendly Energy in Nigeria**

Nigeria, in particular, and Africa, in general, are mostly affected by climate change due to indiscriminate felling of trees, poor management of agricultural lands, and other environmental pollution activities performed by man. It may be difficult to properly plan on the energy requirements of the country due to the lack of an updated population census of the country. It should be noted that the last census in the country was carried out in 2006, which reported an estimated 140 million population, which some regions in the country view as a fraud (NPC 2006). Yet, it was suggested that another census should have been held in 2016. Today, it is already 2020, and this year is not included in the budget allocation of the country. An average of about 200 million people is expected, but it is just an assumption that is yet to be scientifically proven. Thus, if energy (for cooking and heating) requirement of the country is to be adequately budgeted for, the population of the country must know otherwise charcoal production and utilization will continue to increase.

One serious factor is the lack of unique and strategic climate change adaptation policies. Apart from the 2006 forestry policies of the country which have not been adequately implemented owing to its deficiencies, no other specific climate change adaptation policies have been made. Since charcoal production constitutes serious environmental hazard to the climate of the nation, it is expected that climate change adaptation policies will cater for charcoal production and utilization must be put in place (FAO 2010). Included in the factors influencing the choice of alternative environmental friendly sources of energy in Nigeria is the lack of recent and accurate climate information that can be used in the planning for the required energy of the teeming population of the country. Even where it is available, it cannot be relied on because the modern facilities and equipment to be used are not available. The lack of an adequate subject matter specialist to interpret climate information is also an obstacle. The government or relevant agencies cannot afford the required modern climate facilities; thus, effective climate change adaptation strategies cannot be developed in the country. This will also affect the effective dissemination of such data that can be used by farmers, charcoal producers, and other land users for future disasters. Another obstacle is the poor investment in scientific research on the impacts of climate change. It is the amount of human capital invested in the study of climate change impact by relevant professions to enhance the knowledge on how to address the challenges of climate change in the country. Another factor is that most African countries have weak governance. It should be noted that all the three tiers of our government are very weak in terms of the implementation of climate



change adaptation policies. Since the federal government is weak, the local government abuses the forest resources. There is no effective monitoring at the state and local levels on climate change adaptation policies, which further creates serious damage to the climate.

---

### **Strategies to Review the Existing Forest Policy on the Provision of an Enabling Environment for Sustainable Forestry Management and Development in Nigeria**

To achieve an effective forestry management in Nigeria, the following strategies must be implemented. A land-use planning agency (LUPAG) should be established, and it should be noted that the existing land-use plan attached to the Ministry of Lands is obsolete and cannot cope with the trend of development in the country; hence, it should be an autonomous agency. This will enable the agency to really find immediate and long-term solutions to the problems on land utilization in the country.

The forest sector policy should be redefined considering the concepts of cognitive modern forestry. In the past, individuals did not own a forest. People now acquire lands for the purpose of establishing plantation. Land tenure systems and tree ownership should be reviewed. This will make it easier for everyone to have unfettered access to land and improve forestry development in Nigeria. In the ancient tradition of land ownership, a female does not receive support to own land even by inheritance. This practice limits their ability to use their resources to acquire wealth. Emerging products and services should also be considered. Before, only few airports, railways, and other transport services were available in the country. With the increase in population, the demand for these services will also increase, which will definitely have a serious effect on forest resources (FAO 2011). The forestry policy should embrace corporate protection and management measures that will give both the states and the local government areas absolute control of the forest resources. It has been noted that the local governments mostly affected by deforestation do not even bother to campaign for activities to mitigate this. Hence, specific roles should be given to states and local governments.

Another adaptation strategy includes the implementation of law on the regulation of felling of trees. This law exists but is yet to be fully felt. Fellers have a free day in the forest to the extent that they cut economic trees, such as shea, locust bean, mango, and cashew trees, among others. Thus, the “cut-one, plant four” approach should be adopted. All tree fellers must be required to plant four trees as substitutes for a tree that is cut down on their personal lands. Aside the use of government agencies as task force, various community heads should be involved in tree head count and serve as a force to implement the approach. Regulations for the exportation of charcoal are imperative. It should be borne in mind that the consumption of charcoal in Nigeria is lesser than the annual exportation. Europe is taking much of Nigeria’s charcoal, and this has been made possible by the high amount of money paid to the suppliers. In addition, seaports and dry ports in Nigeria were also not properly monitored (Mbura 2015). Monitoring, inspection and enforcement of the

modern method of charcoal production processes: charcoal producers still use obsolete means to produce charcoal and it has adverse effect on the environment in that it causes pollution and endangers the ozone layer (Bailis 2009; Bailis et al. 2015). In charcoal production, sustainably managed resources, such as natural forests, planted forests, and community forests, as well as improved technologies can be used to reduce GHG emissions (Adger et al. 2003; Olson 2009; Vos and Vis 2010). The use of other alternatives to energy, such as agricultural waste and residues of wood and twig outside forests, as well as agroforestry will be advantageous. It is noteworthy that wastes from various crops, such as maize, guinea corn, wheat and oat husks, chaffs of rice, and cassava peels, are left unused and are thus burnt instead of being converted to usable energy. Charcoal dust should be converted into briquettes. Large tonnage of the dust which can be turned into charcoal are left on charcoal production sites and loading stores. However, the rural charcoal producers lack the skills to do this. Better management of local kilns increases efficiency of charcoal production. During the monitoring stage, charcoal producers may not regularly examine the extent of the smoke formed, thereby giving the kiln the opportunity to burn without complete combustion (Otu-Danquah 2010). The use of fossil fuel for transportation should be minimized. The country should research on other energy sources aside from fossil fuel for both household and industrial energy requirements. Cooking energy such as gas should be optimally utilized. If this is achieved, the cost of cooking gas should be within the reach of the poor in rural areas.

---

## Climate Change–Charcoal Chain Sector: The Policy Options

Charcoal climate adaptation value chain is in dire need of policy implementation.

Various government agency regulatory bodies environments are used by charcoal value chain and should be harnessed effectively (FAO 2017). Based on this, policies must be formulated to improve charcoal production technology that will further enhance the sustainable deployment of resources in the forest. Moreover, there is need for an enduring policy projection that will enhance the sustenance of charcoal value chain through diversification and democratization of clean energy alternatives to lessen the increasing demand for charcoal. Incentives, reward distribution, meaningful management of forestry resources, land use planning, landscape management, and a green economy are important to greening the charcoal value chain (Minten et al. 2013). Technological advancement is imperative due to the differences in taxation that could have assisted the incentivization of sustainable sourcing and production of charcoal through fees and licenses. Global fiscal devices related to climate change reduction, such as the clean development mechanism, and reducing emissions from deforestation and forest degradation can provide financial boosts. Effective forest law enforcement and administration are important to boosting government income generation and investments through sustainable forest management and efficient techniques for wood conversion (Sander et al. 2013). To limit the excess of charcoal producers, in May 2016, Nigeria banned charcoal production

when producers and exporters failed to adhere to the cut-one, plant four policy. It was not more than 2 months when a serious outcry from the populace crippled the restriction since charcoal is the major source of energy in the country. “The problem is complicated because the Federal Government owns the policy and the machinery to enforce the law, but the states own the forest. The states also see logging as a form of revenue generation.” Since the government fails in that regard, a serious alternative, such as solar energy, has been targeted as it is environmentally friendly and economically viable. The big question is, how many people could afford it? Nigeria’s National Council on Environment reiterates that the country needs an effective policy to promote solar energy and efficient cooking stove. Although the focus on renewable energy is a right step forward, its success will largely depend on how Nigeria is able to sensitize the people to adopt it. Improved monitoring of rural dwellers can enhance their willingness and preparation to invest in enduring methods. Traditional leaders still hold much title on land acquisition even more than the government. They place difficult conditions on land acquisition which prevent long-term investment in forestry. The transfer of responsibility and provision of financial and human resources to grassroot authorities can boost sustainable forest management and charcoal production. Formulation of policies encourages private sector participation in the dissemination of improved technologies as well as the establishment of marketing system for sustainable products. The government, private sectors, producers, and consumers have a lot to gain through proper planning and decision-making process for charcoal management. Openness in revenue channels and accountability of all players in charcoal production are important to the growth of national and local economies. A solid institutional framework comprising of forest managers, tree growers, charcoal processors, and traders is inevitable to achieve effective coordination of initiatives that will help develop a sustainable charcoal value chain as well as elucidate the mandates of the stakeholders. Charcoal chain reform should establish a firm relationship among major actors. It should be conscious of the danger of corruption as well as protection of the few policies that are designed for the regulation and improvement of the value chain. Measures that will help secure and protect the rights to energy access of those who do not have options should also be considered. For instance, despite the fact that the 2013 European Timber Regulation (EUTR) stipulates that there should be no illegal exportation of any wood products to its members countries, they do not monitor charcoal importation. Charcoal bags are labeled with tags, such as sustainably cultivated, regardless of the type of wood the charcoal is made from.

---

## **Panacea for Greening Charcoal Value Chain**

To improve the charcoal value chain, multiple concurrent interventions should be promoted to significantly lessen GHG emissions (Beukering et al. 2007). A green charcoal value chain needs financial viability that is best guaranteed through the improvement of tenure arrangements and legal access to resources. This will improve the purchase of wood and other biomass for charcoal production. It will

also ensure the merits of a green charcoal value chain for the economies in the countries by placing financial premium on wood resources and incentivizing long-term practices and attractive investments that will induce a smooth movement. A comprehensive national forestry policy framework should be developed for its sustainable administration and integration of charcoal with greater efforts across sectors to reduce the incidence of climate change. This will make climate change specific component of NDCs. Furthermore, governments and other key players should be supported in greening the charcoal value chain through research contribution. There should be holistic methodical examinations of charcoal value chain in major countries where charcoal is produced. In addition, information on GHG emissions at diverse levels of the charcoal value chain should be available (Bailis et al. 2005) as it will facilitate in the greening of the charcoal value chain. The role of charcoal production in deforestation and forest degradation, including other forms of deforestation and forest degradation drivers in urban should be assessed at everytime before leading to devastated level; socio-economic and environmental results and trade-offs of a green charcoal value chain at the local, subnational, national, and regional levels as well as the spread, results from pilot projects, success stories, and research within the entire charcoal value chain are essential.

---

### **Agricultural Adaptation Strategies to Climate Change that Can Reduce Charcoal Production**

Great efforts must be exerted to encourage rural dwellers to go back to farming amidst the climate change that has destroyed the natural environment. Various agricultural adaptation strategies must be adopted to manage the soil resources such as mixed cropping. Mixed cropping is the practice of growing two or more crops together in the same field. It was derived from the traditional method of utilizing land particularly where there is shortage of land. For instance, cereals such as maize, sorghum, and legumes (cowpea and groundnuts) can be planted together. Mixed cropping is advantageous in that it varies in the period of maturity such as maize and cowpea, drought tolerance (maize and sorghum), input requirements (cereals and legumes) and final users of the products (e.g., maize as food and castor oil for cash). Hence, farmers should be encouraged to practice mixed cropping to maximize lands. Improved irrigation efficiency is required to make farming a business throughout all the seasons. Achievement in climate change adaptation depends on the access to adequate water in drought-prone areas. Knowing full well that water can be an inhibiting factor, improved irrigation efficiency is a significant adaptation device toward realizing food demands, especially during off seasons. Harvest during the dry season usually attracts good market price compared with that during the rainy season (Orindi and Eriksen 2005). Thus, there is a need for the adoption of soil conservation measures. Soil conservation deals with the proper timing of various farming activities that demand local experiences, burying of crop residues to improve soil fertility, burning of crop wastes to achieve quick release of nutrients, and allowing animals to graze on farmlands after harvesting crops to

improve soil organic matter. Mulching is also important for controlling soil temperatures and extreme water losses. In addition, it prevents the emergence of diseases and harmful pests and conserves soil moisture. Before the advent of chemical fertilizers, rural farmers heavily depended on organic farming, which reduces GHG emissions. Planting of trees (afforestation) and agroforestry are mechanisms of soil preservation. Tree planting is the technique of transplanting seedlings for the following purposes: forestry, land reclamation, and landscaping. Tree planting in silviculture is called reforestation or afforestation, depending on whether the area that is used for planting is or is not recently forested. It involves planting of seedlings over an area of land where trees and plants have been removed by man, fire, or pest and diseases. The free distribution of tree seedlings to farmers to achieve quick afforestation is a method of adapting to climate change (Akinagbe and Irohibe 2014; Bird et al. 2011). With the reduction in the quantity of available water for crop production, there is a need for crop breeders to provide varieties of crops that are resistant to drought. These crops can be planted in drought-prone areas to lessen their vulnerability to climate change. For example, oat and wheat require fairly less irrigation water compared with dry-season rice. Furthermore, drought resistant crop varieties have been subjected to test by smallholder growers as adaptation methods to climate change in Nigeria, Senegal, Burkina Faso, and Ghana (Ngigi 2009). Furthermore, crop diversification should be encouraged. medium or long time crop production is a possibility in diversification to high-value crops. The diversification of crop planting is an adaptation mechanism prioritized in areas where irrigation is used or not used. Thus, farmers should be encouraged to change the type of crop they plant to curb the risk of low yield from harvest on farm (Orindi and Eriksen 2005; Adger et al. 2003). Crop diversification can be a buffer against variations in rainfall. In addition to the changes in cropping patterns and planting calendars, long-term alterations in rainfall due to climate change can negatively impact crop production. Thus, it is important for extension agents to orient rural farmers. Such an orientation will enable the farmers to familiarize the trend of cropping patterns in their domains. Essentially, shifting from charcoal production to other livelihood activities will prevent our environment from further deterioration. Most rural dwellers consider charcoal production as their last resort to generate income (Eniola 2014). Hence, there is a need to create awareness on other livelihood activities, such as beekeeping, mushroom farming, fish farming, and horticultural farming, among others, with special financial support from the government and other non-governmental agencies.

---

## Conclusion and Recommendations

This chapter concludes that the government in Nigeria needs to exert more effort on climate change adaptation, especially in terms of the eradication or reduction of the threats posed by charcoal production to human health and the environment. Charcoal production cause severe damage to both the environment and humans, thus leading to the reduced number of people engaging in farming activities. Quick actions in ensuring impeding food shortage and rebuilding the forest must be taken so as not to

jeopardize the future need of the forests by the coming generation. The country should strictly adhere to the laws, regulations, and policies of the international bodies on climate change adaptation. Alternative means of livelihood, such as fish farming, mushroom production, vegetable production, and other simple and cheap farming activities, should be embraced by farmers. The reduction of the number of rural dwellers involved in charcoal production will go a long way.

## References

- Adam JC (2009) Improved and more environmentally friendly charcoal production system using a low-cost retort- kiln (eco- charcoal). *Renew Energy* 34:1923–1925. Google Scholar
- Adger WN, Huq S, Brown K, Conway D, Hulme M (2003) Adaptation to climate change in the developing world. *Progress Dev Stud* 3:179–195. Google Scholar
- Akinagbe OM, Irohibe IJ (2014) Agricultural adaptation strategies to climate change impacts in Africa: a review. *Bangladesh J Agric Res* 39(3):407–418. Google Scholar
- Arnold MJE (2001) Forestry, poverty and aid. CIFOR occasional paper no. 33. Centre for International Forestry Research, Bogor. Google Scholar
- Arnold JEM, Köhlin G, Persson R (2006) Woodfuels, livelihoods and policy interventions: changing perspectives. *World Dev* 34(3):596–611. Google Scholar
- Bailis R (2009) Modeling climate change mitigation from alternative methods of charcoal production in Kenya. *Biomass Bioenergy* 33:1491–1502. Google Scholar
- Bailis R, Ezzati M, Kammen DM (2005) Mortality and greenhouse gas impacts of biomass and petroleum energy futures in Africa. *Science* 308:98–103. Google Scholar
- Bailis R, Drigo R, Ghilardi A, Masera O (2015) The carbon footprint of traditional wood fuels. *Nat Clim Chang* 5:266–272. <https://doi.org/10.1038/nclimate2491>. Google Scholar
- Beukering PJH, Kahyarab G, Massey E, di Prima S, Hessa S, Makundi V, van der Leeuw K (2007) Optimization of the charcoal chain in Tanzania. PREM (Poverty Reduction and Environmental Management working paper) 07/03. Institute for Environmental Studies, Amsterdam. Google Scholar
- Bird ND, Zanchi G, Pena N, Havlík P, Frieden D (2011) Analysis of the potential of sustainable forest-based bioenergy for climate change mitigation. Working paper no. 59. Bogor Indonesia Center for International Forestry Research (CIFOR), Bogor. Google Scholar
- Chidumayo EN, Gumbob DJ (2012) The environmental impacts of charcoal production in tropical ecosystems of the world: a synthesis. *Energy Sustain Dev* 17:86. <https://doi.org/10.1016/j.esd.2012.07.004>. Google Scholar
- Chris P (2007) The age of wood: fuel and fighting in France forests. 1940–1944, Retrieved September 10, 2009, from <http://www.histroycooperative.org/journals/ch/11.4/pearson.html>
- Emedilichi HM (2018) Assessment of charcoal production processes and the environment impact in Kaduna, Nigeria. *Resour Environ* 8(5):223–231. <https://doi.org/10.5923/j.re.20180805.02>. Google Scholar
- Eniola PO (2014) Perceived environmental and health effects of charcoal production among rural dwellers in agro-ecological zones of Nigeria. U.I PhD thesis. 2014. Google Scholar
- FAO (2010) What woodfuels can do to mitigate climate change. FAO forestry paper no. 162. FAO, Rome. Google Scholar
- FAO (2011) Framework for assessing and monitoring forest governance. FAO and the Program on Forests (PROFOR), Rome. Google Scholar
- FAO (2017) The charcoal transition: greening the charcoal value chain to mitigate climate change and improve local livelihoods by J. van Dam. Food and Agriculture Organization of the United Nations, Rome. Google Scholar
- FAO (2018) FAOSTAT ON CHARCOAL, Food and Agricultural Organization of the United Nations, 2017, pp 34–45. Google Scholar

- Federal Ministry of Environment (2006) Forestry policies, pp 24–78. Retrieved 12th January 2021 from <http://www.fao.org/forestry/15148-0c4acebeb8e7e45af360ec63fcc4c1678.pdf>. Google Scholar
- Iloje OC (2002) Renewable energy development in Nigeria: status and prospects. Ed. O.E. Ewart. Proceedings of a National Workshop on Energising Rural Transformation in Nigeria: Scaling Up electricity Access and Renewable Energy market Development. Federal Ministry of Power and Steel, Abuja Nigeria. March 19–20 2001, 180. ICEED
- Mburia R (2015) Africa climate change policy: an adaptation and development challenge in a dangerous world. Climate Emergency Institute, UNEP, Kenya Google Scholar
- Minten B, Sander K, Stifel D (2013) Forest management and economic rents: evidence from the charcoal trade in Madagascar. *Energy Sustain Dev* 17(2):106–115. Google Scholar
- National Population Commission (2006) Census news: a house magazine of the 2006 National Population Commission, pp 1–88. Retrieved 13th January, 2021 from <https://nigeria.opendataforafrica.org/ifpbxbd/state-population-2006>. Google Scholar
- Ngigi SN (2009) Climate change adaptation strategies: Water resources management options for smallholder farming systems in Sub-Saharan Africa. The MDG Centre for East and Southern Africa, the Earth Institute at Columbia University, New York, p 189. Google Scholar
- NL Agency (2010) Making charcoal production in Sub Sahara Africa sustainable. NL Agency and BTG Biomass Technology Group BV, Utrecht. Google Scholar
- Ogundele AT, Eludoyin OS, Oladapo OS (2011) Assessment of impacts of charcoal production on soil properties in the derived savanna, Oyo state, Nigeria. *J Soil Sci Environ Manage* 2(5):142–146. ISSN 2141-2391 ©2011 Academic Journals. Google Scholar
- Oguntunde PG, Abiodun BJ, Ajayi AE, Giesen N (2008) Effects of charcoal production on soil physical properties in Ghana. *J Plant Nutr Soil Sci* 171:591–596. Google Scholar
- Olson AR (2009) A smoke burner for charcoal kilns. Northeastern longer 1941. A portable charcoal kiln. Connecticut Agric. Experiment Station Bull 448 New Haven. Google Scholar
- Orindi VA, Eriksen S (2005) Mainstreaming adaptation to climate change in the development process in Uganda. *Ecopolicy series 15*. African Centre for Technology Studies, Nairobi. Google Scholar
- Otu-Danquah KA (2010) Current status of charcoal demand and supply, and initiatives on improved cook-stoves. A presentation made during a kickoff meeting for TEC/ESMAP survey on the energy access and productive uses for the urban poor, held in the SSNIT Guest House Conference Room, Accra. On 11 Aug 2010, p 23. Google Scholar
- Pabi O, Morgan EA (2002) Land-cover change in the Northern Forest-Savannah Transition in Ghana, commissioned technical report for the NRSP R7957 project. Retrieved April 23 from [www.nrsp.org/pubs/index.rsp](http://www.nrsp.org/pubs/index.rsp). Google Scholar
- Sander K, Gros C, Peter C (2013) Enabling reforms: analyzing the political economy of the charcoal sector in Tanzania. *Energy Sustain Dev* 17(2):116–126. Google Scholar
- Seidel A (2008) Charcoal in Africa importance, problems and possible solution strategies. Deutsche Gesellschaft für Technische Zusammenarbeit (GTZ) GmbH, Household Energy Programme – HERA Eschborn, Apr 2008, pp 28–35. Google Scholar
- Shackleton CM, Shackleton SE, Buiten E, Bird N (2006) The importance of dry woodlands and rainforests in rural livelihoods and poverty alleviation in Southern Africa. *Rainforest Polit Econ* 9(2006):558–577. Google Scholar
- Stefan C (2009) Fundamentals of charcoal production. National bioenergy center IBI conference on biochar, sustainability and security in a changing climate, pp 68–92. Google Scholar
- Stockholm Environment Institute (SEI) (2016) How Kenya can transform the charcoal sector and create new opportunities for low-carbon rural development. Discussion brief. Stockholm Environment Institute. (SEI). Available at [www.sei-international.org/mediamanager/documents/Publications/SEI-UNDP-DB-2016-Kenya-sustainable-charcoal.pdf](http://www.sei-international.org/mediamanager/documents/Publications/SEI-UNDP-DB-2016-Kenya-sustainable-charcoal.pdf). Google Scholar
- The World Forest Movement (2006) State of charcoal in Nigeria economy: Effects on governance. Upland Press, p 8
- Tzanakis N, Kallergis K, Bouros EB, Samiou FS, Siafakas NM (2001) Short-term effects of wood smoke exposure on the respiratory system among charcoal production workers. *Chest* 119(4):1260–1265. Google Scholar

- United Nations Climate Change (2020) 2020 United Nations Framework Convention on Climate Change. Retrieved from <http://www.unfccc.int/topics/adaptation-and-resilience/the...> Google Scholar
- United Nations development Programme (UNDP) (2005) Basing national development on the millennium development goals. Retrieved August 20, 2008, from <http://www.cifor.cgiar.org>. Google Scholar
- United Nations FCCC (2015) United Nations framework convention on climate change. Retrieved September 28, 2020 from <http://unfccc.int/resource/docs/2015/cop21/eng/109r01.pdf>. Google Scholar
- VCCCAR (2020) Victorian Centre for Climate Change Adaptation Research. Climate change adaptation definitions. Retrieved June 11 2020 from <http://www.vcccar.org.au/climate-change-adaptation-definitions>. Google Scholar
- Vos J, Vis M (2010) Making charcoal production in Sub Sahara Africa sustainable. NL Agency, Utrecht. Google Scholar
- Williams A (1993) An overview of the use of woodfuels in Mozambique and some recommendations for biomass energy strategy. National directorate of forestry and wildlife/biomass energy unit, p 250
- World Bank (2004) Harvesting opportunities. Rural development in the 21st century. IV Regional Thematic Forum. Printed from the World Bank Group. Latin America and The Caribbean, p 248. Google Scholar
- World Bank (2011) Economics of adaptation to climate change. Retrieved June 11 2020 from <http://www.worldbank.org/en/news/feature/2011/06/06/...> Google Scholar
- World Energy Council (WEC) (2004) Comparison of energy systems using life cycle assessment. London, p 45. Google Scholar

**Open Access** This chapter is licensed under the terms of the Creative Commons Attribution 4.0 International License (<http://creativecommons.org/licenses/by/4.0/>), which permits use, sharing, adaptation, distribution and reproduction in any medium or format, as long as you give appropriate credit to the original author(s) and the source, provide a link to the Creative Commons license and indicate if changes were made.

The images or other third party material in this chapter are included in the chapter's Creative Commons license, unless indicated otherwise in a credit line to the material. If material is not included in the chapter's Creative Commons license and your intended use is not permitted by statutory regulation or exceeds the permitted use, you will need to obtain permission directly from the copyright holder.







# Managing Current Climate Variability Can Ensure Water Security Under Climate Change

# 112

Mike Muller

## Contents

Introduction .....	2312
Characterizing Hydrological Variability and Climate Change Impacts .....	2314
Current Hydrological Variability .....	2314
“Easy” Versus “Difficult” Hydrologies .....	2314
Climate Change Science Has Helped to Characterize Climate Variability .....	2315
Predictions of Climate Change Impacts on Hydrological Processes .....	2316
Tools to Manage “Dynamic Stationarity” .....	2318
Right Tools for the Right Job: But which Job? .....	2318
What Tools Are Available? .....	2319
Methods to Determine the Scale of Maximum Probable Events .....	2320
Right Tools in the Right Place: At the Right Time .....	2320
From Tools to their Application: Some Case Studies .....	2321
Cape Town’s Day Zero Drought: A Failure to Acknowledge Risks of Climate Variability .....	2322
Mombasa, Kenya: Climate-Resilient Designs Constrained by Institutions and Finance .....	2323
Windhoek, Namibia: A Climate Secure Source Using Groundwater as Storage .....	2324
Beira, Mozambique: Sea Level Rise Will Compound Existing Challenges .....	2325
Polihali Dam and the Integrated Vaal River System: Sustaining a “Problemshed” .....	2326
Zambezi River Coordination: Drought Risks, Discount Rates, and Batoka Dam Hydropower .....	2327

This chapter was previously published non-open access with exclusive rights reserved by the Publisher. It has been changed retrospectively to open access under a CC BY 4.0 license and the copyright holder is “The Author(s)”. For further details, please see the license information at the end of the chapter.

M. Muller (✉)

Wits School of Governance, University of the Witwatersrand, Johannesburg, South Africa

e-mail: [mike.muller@wits.ac.za](mailto:mike.muller@wits.ac.za)

© The Author(s) 2021

W. Leal Filho et al. (eds.), *African Handbook of Climate Change Adaptation*,  
[https://doi.org/10.1007/978-3-030-45106-6\\_243](https://doi.org/10.1007/978-3-030-45106-6_243)

2311

Discussion: Principles to Guide Adaptation under Uncertainty .....	2330
Principles .....	2330
Operational Priorities .....	2333
Conclusions .....	2333
References .....	2334

## Abstract

Water resources will be significantly impacted upon by climate change, and these impacts will be transmitted to the many sectors and services dependent on them. The nature, extent, and timing of these impacts remain uncertain, but the long lifetime of water infrastructures requires that their planning, development, and operations should be resilient to climate changes. An effective approach is to focus on the management of current climate variability as it relates to water, which strengthens the ability of communities and countries to foresee, manage, and adapt to the impacts of longer-term climate change on water-related activities. This approach is illustrated by cases from Southern and Eastern Africa.

Current “stationary” stochastic methods of hydrological analysis can still be used under assumptions of a “dynamic stationarity” although more regular updating of hydrological data will be required. Methodologies to evaluate economic dimensions of risk reduction introduce additional uncertainties but may help decision-makers to understand the risks and opportunities. Diversification of sources and sequencing of resource development pathways are helpful strategies to adapt to climate change but must ensure that risks affecting different sources are not correlated. Attention must also be given to demand-side interventions in order to reconcile supply and demand, and these perspectives must be shared with social, economic, and political actors to ensure that strategies are communicated, understood, and supported by the wider community.

## Keywords

Water resources · Climate adaptation · Climate variability and change · Water supply · Hydropower · Hydrology · Stationarity · Utility economics · Public finance

## Introduction

There is international agreement at the UNFCCC about the need for collective action to address the likely impacts of global warming on human societies. One response has been to encourage all sectors of society to identify and implement actions that can help adapt to the emerging impacts of climate change and work to mitigate its drivers.

Water resources and the services dependent on them are an integral part of the climate system (Chahine 1992). Because of this, the managers of water resource systems and of the services that depend on them must develop appropriate responses to the potential impacts of climate change (Strzepek et al. 2011).The African

continent is considered to be particularly vulnerable to these impacts both because of their magnitude and because African societies have less physical, financial, and human resources available to address these impacts.

A further challenge is that the impacts of climate change on water resources are local, diverse, and not well-characterized. Unlike the general global warming trend, for which there is robust evidence that is consistent with the predicted impact of anthropogenic activities, direct evidence of significant changes in hydrological variables is not nearly as strong and consistent.

For example, it appears that at a global level, precipitation is increasing (Adler et al. 2017). However, models predict increases in drought frequency over significant areas due to warming (Ukkola et al. 2020) although empirical evidence in support of this is limited (Hegerl et al. 2019) and predictions are based on various definitions of drought.

While warming trends are a direct result of anthropogenically induced atmospheric changes that act through a single dominant mechanism at global level, the impacts on the main hydrological processes – evaporation, precipitation, runoff, and infiltration – are secondary and tertiary effects that are further influenced by a wide variety of mechanisms at a local, regional, and global level. So while there is only a limited increase in global precipitation averages, there are more extensive regional variations and substantial changes in parameters such as rainfall intensity (Trenberth 2011) which, coupled with the impact of warmer temperatures on aridity, lead to changes in tertiary variables such as stream flow.

The likely impact of climate change on hydrological processes is generally still too uncertain to make it possible for water resource planners and managers to identify locally specific adaptive measures. So climate change models and predictions cannot usually guide well-founded planning and operational decisions although they do help to suggest the boundaries for extreme events.

However, policy-makers like the UN High-Level Panel on Water want to know what impacts global warming will have on water systems and how they will be dealt with. It is suggested that an appropriate response is to continue to build on the great strength of best practice in water resource science and management, which is its ability to characterize and manage climatic *variability*. This requires that the approaches used move beyond the assumptions of a stationary hydrology and can accommodate a changing climate (Brekke et al. 2009).

Yet water managers are already responding to climate change through their management of current climate variability. However, to make this case convincingly, they must demonstrate that current methodologies are adequate for the task. To address this in an African context, this chapter:

- Characterizes the “difficult hydrologies” that pose particular challenges in Africa and shows how climate change science has helped to understand the climate variability inherent in those hydrologies
- Considers some analytical tools that are used to manage under assumptions of “stationary hydrology” and whether they can be adapted reflect “dynamic stationarity”

- Presents six African cases that illustrate how the management of current variability is supporting adaptation to potential climate change impacts

Drawing on lessons from these cases, some conclusions are drawn about approaches that, while deriving from current hydrologies, are more explicitly adaptive and will be resilient in an uncertain future.

A supply-side focus is taken because the availability of water is most directly impacted upon by climate change. The demand side is equally important and challenging, but human behavior and social institutions that guide it merit separate consideration. The reconciliation of supply and demand remains the ultimate technical goal of water management.

---

## **Characterizing Hydrological Variability and Climate Change Impacts**

### **Current Hydrological Variability**

Climate warming due to anthropogenic activity is a global phenomenon, but its specific impacts on water resources depend on local conditions, including current climatic variability. Water resource managers need to characterize that current variability if they are to manage it successfully. This characterization provides the foundation from which to review the impacts of climate change on water resources and the hydrological cycle.

The primary driver of the hydrological cycle is the interaction between incoming solar energy and the large mass of water in the oceans. However, water managers necessarily focus on rainfall, whose duration, intensity, and distribution in space and time drive other elements of the hydrological cycle: surface runoff, infiltration, and evapotranspiration. The interaction between these variables then determines the stream and groundwater flows, whose magnitude and fluctuation are the “raw material” of water resource management.

### **“Easy” Versus “Difficult” Hydrologies**

From this perspective, climate creates the hydrological context both for the “natural” biosphere and for human communities and their activities that depend on it. But it is the variability of climate as much as the average values of its component elements that determines whether the resulting hydrological context enables communities to establish and sustain productive and congenial environmental niches. Grey and Sadoff (2007) echo previous investigators, suggesting that climatic variability has been a determining factor in the social and economic development of different societies.

A nation's hydrology will clearly affect the level of institutions and investment required to achieve water security. The absolute levels of water resource availability, its inter- and intra-annual variability and its spatial distribution, coupled with the demand for water, will largely determine the institutions and the types and scale of infrastructure needed to manage, store and move the resource. The resilience of the structure of the economy to water shocks, together with societal resilience and risk aversion will also be determinants of the level of investment required for specific countries to reach the tipping point of water security.

A distinction is drawn between "easy" and "difficult" hydrological legacies. An "easy" hydrology is characterized by adequate rainfall with little variation between seasons and years. Such hydrologies sustain predictable perennial river flows, supported by reliable groundwater availability. The predictability of the hydrology and its relative consistency makes the management of water for different purposes relatively easy, facilitating the conceptualization and operation of infrastructure as well as the establishment of the rules that govern the entitlements and obligations of water users.

Regions with difficult hydrologies require stronger institutions as well as higher levels of physical investments in order to support basic activities such as agriculture or even simply to meet domestic needs. One reason that many poor countries remain poor is that they could not accumulate the resources needed to achieve the water security on which higher levels of development depend. As summarized, difficult hydrologies include:

- Absolute water scarcity
- Low-lying lands subject to severe flood risk
- Markedly seasonal rainfall which requires the storage of water
- High inter-annual climate variability, where unpredictable risks require over-year storage
- A combination of extreme intra-annual seasonality and inter-annual variability

This crude distinction between difficult and easy hydrologies highlights the need to understand existing climate variability before focusing on the potential impacts of climate change. At the least, water managers need to understand the key systems that drive their local climate and the extent of uncertainty about the resulting rainfall patterns and related hydrological parameters in order to identify sustainable strategies for their water resource development and management.

## **Climate Change Science Has Helped to Characterize Climate Variability**

Paradoxically, climate change science must build on an understanding of "normal" climate variability in order to attribute any phenomenon to climate change rather than simply a "normal" extreme. So while the Sahel droughts of the 1970s/1980s were often attributed to climate change, evidence of subsequent "rainfall recovery"

suggests that this was simply long-cycle climate variability, perhaps aggravated by land- and water-use changes (Sidibe et al. 2018).

There are similar debates about changes in the intensity and frequency of the occasional and unpredictable tropical storms, an important factor in the hydrology of Southeastern Africa (Malherbe et al. 2012). Claims that those storms were becoming more frequent and intense due to global sea warming have subsequently been challenged, since the 35-year-long satellite data set on which they were based is relatively short; it is now suggested that tropical storm formation was mostly influenced by long-cycle variations in the phenomena such as ENSO and the Indian Ocean Dipole (Chan 2006).

The hypothesis that storm frequency is increasing due to global warming is also not supported by later studies, and it is even suggested that south of the tropic of Capricorn, where storm numbers were expected to increase, they have actually decreased (Pillay and Fitchett 2019). However, the debate continues, and there is continuing uncertainty about likely changes in cyclone frequency and their regional prevalence (Knutson et al. 2020).

Variations in lake levels are also often attributed to climate change with recent fluctuations in Africa's lakes Victoria, Chad, and others specifically cited, although with acknowledgment that human influence is also a factor. Yet many of Africa's shallower African lakes are known for their variable levels (Conway 2005).

Lake levels are arguably more useful as indicators of the impact of climate *variability* than climate *change* since they are determined by the climate over the lakes and their catchment areas as well as the impact of human activity. A recent global review found that background climate variation due to multi-decadal climatic oscillations such as ENSO accounted for 58% of the variation in lake levels; a further 10% variation was due to normal seasonal effects. It was concluded that apparent trends attributed to anthropogenic activities were often exaggerated by this "normal" background variation and that due attention should be given to background climate variation before claiming climate change impacts (Kraemer et al. 2020).

These examples show that it is necessary to correct the current popular (and academic) discourse in Africa and elsewhere which sees water managers, policy-makers and political heads attribute many extreme events to climate change, although climate records show that neither the event nor its frequency of occurrence is inconsistent with patterns evident in the historical record.

## **Predictions of Climate Change Impacts on Hydrological Processes**

There is no doubt that global warming is already having a variety of impacts on hydrological systems. However, while some impacts are known, others are uncertain and are likely to vary significantly from place to place. These uncertainties need to be better understood and communicated by practitioners to policy-makers and publics.

Some climate change impacts are directly related to the impact of anthropogenic warming on specific hydrological variables. While the water-holding capacity of air

increases with temperature, this does not necessarily mean that global rainfall will increase at the same rate. However, recent work concludes that observations confirm modeling predictions that rainfall does increase with rising temperatures and that this is associated with a change in the intensity and timing of rainfall events (Giorgi et al. 2019). It is also evident that there are regional changes in the distribution of rainfall although uncertainties remain about these important relationships (Herold et al. 2017).

Similarly uncertain is the impact of warming climates on soil moisture, a hydrological variable that underpins the agricultural activities on which human societies depend and which are, by far, the largest direct “users” of water. Aridity, the ratio between precipitation and potential evapotranspiration, is expected to impact on surface water runoff, a critical process for water management.

Aridity might be expected to increase with global warming since evapotranspiration is greater under higher temperatures, but this is not universal. Globally, some arid areas (in the Americas) have become wetter, whereas previously semi-humid areas (particularly in Asia) became drier. And significant discrepancies are reported between model predictions and direct observations leading to warnings that the general conclusion that climate change will result in “overall drier conditions across the globe” might be “at least partly misleading” (Greve et al. 2019).

The discrepancies are attributed, in part, to the fact that the increased CO<sub>2</sub> that drives global warming also changes the vegetation types, which may use water more efficiently. As the authors explain, “...changes in atmospheric CO<sub>2</sub> break the existing correlation between hydrology and ecology by changing the water use efficiency of photosynthesis.”

These issues are important for sub-Saharan Africa where bush encroachment is reducing the animal carrying capacity of semiarid rangelands although human changes in land use are at least as important as climate change in driving this process (Venter et al. 2018). What is important for water managers is that changes in aridity and land cover will change the relationship between rainfall and runoff, potentially affecting water resource availability (Zareian et al. 2017) and leading to significant stream flow reductions.

These processes are complex, and outcomes will be determined by locally specific conditions. The proportion of rainfall that reaches a stream or recharges groundwater is determined by the amount of rainfall, its intensity and duration, prior soil moisture, as well as temperature and land cover. One response to this complexity has been to apply catchment models, developed to provide guidance on rainfall-runoff relationships. But these models are based on historical circumstances that may not be appropriate under new conditions of climate and land cover. In Australia, historical rainfall-runoff models might produce valid results under future climates, but only if rainfall changes were relatively modest (Vaze et al. 2010). In Europe while runoff correlates closely with soil moisture, relations with precipitation and temperature are weaker, and a recent survey identified a better understanding of runoff dynamics as a priority “unsolved question” for hydrologists (Blochl et al. 2019).

## Tools to Manage “Dynamic Stationarity”

There will clearly be continuing uncertainty about climate change-driven hydrological trends due to the wide diversity of water resource contexts in which hydrological processes occur. Furthermore, substantial “normal” variability will often mask smaller climate change impacts.

It is thus appropriate for practitioners to focus explicitly on managing climate variability. This is not an argument for “stationarity” (the assumption that climate is not changing) nor a suggestion that water resource planners should ignore warming-related climate change. Rather, it is a practical response. While it has long been accepted that hydrological analysis must reflect the changing climate (Moss and Tasker 1987), tools developed under assumptions of “stationary” hydrology may yet be used under the new conditions of hydrological dynamism (Milly et al. 2008).

## Right Tools for the Right Job: But which Job?

Water resource practitioners use a wide variety of tools to guide their decisions, but their tools’ limitations and their adaptation to address changing climates must be considered in the context of the functions that they support. These include:

- Monitoring and information management, about both resource availability and resource use
- Planning, to determine trends in resource availability and use and to inform options, identification, and analysis
- Allocation, to ensure that water use achieves society’s objectives within the constraints imposed by the resource itself
- Development of infrastructure, to make water available for use as well as to maintain its quality
- Sustainable operation of complex infrastructure systems
- Protection of the environmental condition of the resource

The timeframe and nature of guidance that will be required vary dramatically between the functions, and the tools provided have to be appropriate for the purpose:

- Planning requires projections of the yield available from different sources and systems, often over very long time horizons (50–100 years in the case of large systems) with indications of assurance derived from assumptions about the variability of the resource. While climate change is clearly relevant over long time horizons, planning does not necessarily commit to specific actions until firm decisions are taken.
- Infrastructure must optimize output based on design requirements and be guided by estimates of the magnitudes of extreme events that could lead to failure. The long lifetime of water resource infrastructure limits the subsequent adoption of alternative options and enforces a degree of “path dependence” (Hüttl et al. 2016).



- System operation needs short-term (seasonal up to 5 years) guidance to maintain supply assurances, while flood routing requires real-time models.
- Water allocations to users must be informed by “normal” availability of supply but allow adjustment for contingencies such as drought as well as to cater for future climate change (which is often missing from legal frameworks despite earlier warnings (Trelease 1977)).

In summary, water resource managers must be enabled to (i) make reasonable predictions about the potential yield of sources and systems over time; (ii) provide guidance based on variability parameters to support system restrictions during drought; (iii) provide robust, conservative information about risks posed by extreme flood events; and (iv) operate their systems to achieve reasonably predictable outputs under variable conditions.

## What Tools Are Available?

Simple rainfall-runoff models, developed to support urban drainage design and flood estimation, were of limited value in larger catchments, particularly in the absence of information on rainfall characteristics. The development of stochastic techniques to provide rainfall and river flow estimates and guide reservoir operation greatly expanded the analytical capabilities of water planners.

The complex relationships between hydrological variables, the diversity of situations, and the volume of data involved meant that key concepts could only be translated into tools for practitioners when modern computing power became available. The Harvard Water Program developed many methodologies using “synthetic” or stochastic hydrologies (Maass et al. 1962) not just to solve hydrological questions but also to support the economic optimization of water projects.

There is now a wide variety of hydrological tools and methodologies that have been applied. Loucks and van Beek’s extensive compendium (2017) (Loucks and Van Beek 2017) links the technicalities of methodologies and models to their application in real-world planning problems. These are supported by new streams of data from remote sensing although this does not fully compensate for the decay in the physical observation network (World Bank 2018a). The challenges posed by climate change have led to suggestions that a new Harvard Water Program is needed.

To address some of the functions outlined above, tools used include the following:

### Stochastic Methodologies to Estimate Flow and Rainfall

The stochastic methodologies described above have transformed water management. When applied with the requisite caution and skill, they enable planners to extend short flow or rainfall records to provide reasonable estimates of mean and extreme flows at different levels of assurance as well as to provide synthetic “records” for ungauged rivers and catchments. Stochastic models lend themselves to testing hypotheses about the potential impacts of changes in rainfall patterns and (given

the computing power now available) can generate and test large numbers of synthetic sets of rainfall and flow to determine sensitivities to different climatic circumstances. Climate change does, however, mean that the value of such methodologies depends on the regular updating of the data on which they are based.

### **Catchment-Scale Rainfall-Runoff Models to Support Yield and Operations**

Catchment-based rainfall-runoff models are also widely used to estimate the potential yield of different sources and systems and to support operations ranging from drought management to flood routing. The rainfall-runoff relationships can be extrapolated from known areas to similar, poorly gauged catchments to predict stream flows and guide water management more generally (Vogel 2017). Such models can provide a structured basis for yield estimation taking account of new flow and rainfall records and changes in land use (see, for instance, the South African framework which has evolved over the past 60 years) (Bailey and Pitman 2016). While the maintenance of these models requires consistent investment in both physical data collection and subsequent processing, they provide an invaluable basis for the planning, expansion, and operation of large systems. The evolution of the planning and operational models for South Africa's Vaal River System (see below) provides an instructive insight.

### **Methods to Determine the Scale of Maximum Probable Events**

A particular challenge in designing large water resource infrastructure is to ensure that it is resilient to the most extreme event "likely." The primary determinant of the scale of the "probable maximum flood" is the probable maximum precipitation. Since the objective in determining the PMF is to identify a worst-case scenario, this is a case where the application of multiple climate models can be useful since there will be a strong argument for selecting the highest value generated (Gangrade et al. 2018). For these kinds of events, in large catchments, catchment dynamics and land-use changes have less influence.

---

### **Right Tools in the Right Place: At the Right Time**

One consequence of the huge diversity in the local hydrological regimes on which societies' water supplies depend is that technical paradigms that work well in one context have often been promoted inappropriately in others (Woodhouse and Muller 2017). Aid-dependent African countries have been particularly vulnerable to this trend because approaches promoted often reflected donor country conditions or the educational system in rich countries simply assumes that its approach is globally appropriate (Briscoe 2010). The promotion of a reliance on "green infrastructure" rather than built infrastructure is a recent incarnation of this trend (Muller et al. 2015).

While environmentally focused approaches may be appropriate in temperate developed countries, they do not help communities under more challenging climates in Africa, Asia, and Latin America where populations and economies are growing rapidly. Aside from the socioeconomic conditions, there are dramatically different topographies, geologies, and climatic conditions of aridity and often greater inter-seasonal and inter-annual variability of temperature and precipitation.

There are stark contrasts in the physical context for water resource management even in developed regions, between Europe's temperate northern regions and its Mediterranean south and temperate northeastern USA, its humid, subtropical southeast, giving way to semiarid southwest. In each region, the character of water resources and thus the options available to address water resource challenges are different, and different tools of analysis will be used. A further key differentiator is the human and financial resources that can be brought to bear: "With increasingly 'difficult' hydrology, the level of institutional refinement and infrastructure investment needed to achieve basic water security becomes significantly greater than in temperate (and less variable) climates" (Grey and Sadoff 2007).

There must be appropriate responses to current variability and uncertainty before the particular challenges of climate change can be addressed. For many countries, the priority problems relate to present water insecurity, not future climate change. As the cases below show, responses to, for instance, urban water shortages are unlikely to be much altered by considerations of climate change.

When solutions proposed could increase future costs and risks, climate change considerations become important. What is most immediately important in (relatively) poor communities and countries that do not have acceptable levels of water security is the efficient and effective use of scarce resources to deal with current variability. Many recent water "crises" popularly attributed to climate change have been the consequence of a failure to prepare for current variability. Opposition to long-run investment decisions (Matalas 1997) aggravates immediate problems, with limited evidence of long-run negative consequences. Often, it reflects policy preferences rather than any well-founded evidence of harm or risk (Muller et al. 2015)

---

## From Tools to their Application: Some Case Studies

Water management practitioners have available a plethora of tools of increasing complexity and cost (as measured in human resources, finances, and data) to help them to manage climate variability. Yet the extent to which these tools can help water managers to address the challenges of climate change is limited. How should the practitioners proceed?

This is more than a technical issue. Water is managed to achieve a wide variety of societal goals, and water managers operate under a range of technical, financial, as well as social and political constraints and produce a variety of economic benefits. Tools to analyze the performance of water projects are also needed to assess their financial risks and economic returns in many different contexts.

A new mining or agricultural business may require a secure water supply. Governments seek to reduce poverty and promote greater economic inclusion by providing irrigation water, enabling poor farming communities to improve their productivity. Power utilities seek competitive, reliable energy sources. Urban managers, concerned about the disruptive effects of water restrictions due to drought, want to enhance water security.

Water managers and their institutions must be able to respond authoritatively to both political decision-makers and their wider communities. Most stakeholders will be concerned about the risks that climate change is assumed to pose and will need some assurances that these have been adequately addressed.

In this section, a number of cases from Southern and Eastern Africa are presented that show how water managers have used available tools to achieve specific water management objectives by addressing climate variability and concerns about climate change. The cases locate climate variability and change challenges in a wider socioeconomic context and consider whether the approaches adopted have increased resilience to potential climate change impacts. Three of the cases were included in a World Bank study of resilience in African infrastructure which aimed to develop processes that support “robust decision-making” (RDM) (Cervigni et al. 2015).

## **Cape Town’s Day Zero Drought: A Failure to Acknowledge Risks of Climate Variability**

Between 2015 and 2018, droughts in the extreme south west of South Africa saw the City of Cape Town suffering serious water restrictions. It was widely reported that the city faced a “Day Zero” on which its water supplies would “run out.” These events, copiously documented, were widely attributed to climate change.

However, over the previous decade, there had been repeated recommendations from national technical and planning agencies calling for investments to augment, by 2015, the supply capacity of the Western Cape Water Supply System (WCWSS), on which the city depends (Muller 2018). These recommendations were based on a long-term WCWSS strategy study, informed by a hydrologically based system model that had successfully been used for two decades.

The model’s projections of the supplies reliably available from existing sources were set against projections of water demand in a “reconciliation” process. This identifies any requirement for increased supply, the primary driver being the needs of Cape Town’s growing population. The interventions proposed were sequenced on a “least-unit-cost” basis. Records of meetings in 2013 and 2014 suggest that the city believed that its efforts to manage demand had constrained growth and that further supply expansion would only be required in 2022.

Even before the drought ended, implementation had begun of infrastructure projects that had earlier been rejected – including water reuse and groundwater development as well as additional surface water. Consideration is also being given to a large desalination installation which could be used during drought periods.

The vulnerabilities of the WCWSS are now obvious. The system depends on rainfall over a small (800km<sup>2</sup>) area of mountain catchments supplying dams whose

storage is less than 2 years of “normal” use. Climate change dynamics are also under review. Cape Town lies at the edge of dominant rain-producing weather systems and has long been identified as an area vulnerable to climate change-driven rainfall reductions (Archer et al. 2019). From an adaptation perspective, the questions are whether the shift of weather system is permanent and the nature of an appropriate adaptation response.

The city’s new postcrisis strategy (Cape Town 2019) acknowledges continued dependence on surface water for 75% of its supplies for at least the next decade, while alternative sources such as reuse, groundwater, and desalination are developed to provide a greater proportion of supplies in the future.

Climate uncertainty is specifically addressed. The program aims to increase the assurance of supply from the system from 98% to 99.5% but acknowledges that there might be “a step change in rainfall due to climate change . . . . If this turns out to be the case, the programme will be both accelerated and expanded.”

The strategy also acknowledges that water investments must provide regular supplies during periods of low rainfall: “All water schemes provide insurance against periods of low rainfall, which may become more frequent and more severe as a result of climate change.” It recognizes that expensive supplies from reuse and desalination will not be used all the time but concludes: “. . . this will not have been wasteful expenditure. The future is uncertain, and the cost of very severe restrictions is much higher than the cost of insuring against this likelihood.”

In this regard, the city’s strategy now explicitly addresses climate change. But rather than placing reliance on forecasting future availability, it seeks to increase reliability (through infrastructure investment originally proposed to address variability) to “buy time” for implementing rapid interventions such as desalination if required.

## **Mombasa, Kenya: Climate-Resilient Designs Constrained by Institutions and Finance**

Greater Mombasa, Kenya’s second largest city, had a population of approximately three million people in 2018. It is Kenya and the East African region’s primary port and is also a center for international beach tourism which complements the country’s inland game park complexes.

Water supply is deeply deficient. Water requirements are estimated to be in the region 250 Ml/day, but the city is in a permanent state of water crisis, able to provide less than 30% of this potential amount (Foster et al. 2020). Small supplies from local coastal aquifers are at the limit of their available capacity and face problems of salinization. The city’s primary supply comes from two distant groundwater sources, the Mzima Springs (200 km away) and Baricho (100 km).

Unusually, local surface water sources had not been tapped although the need for a new source had already been identified in the early 1990s. The preferred augmentation project, now in preparation, is a dam on the small, local Mwache River.

All five projects in the 2015 World Bank infrastructure resilience study (Cervigni et al. 2015) which included Mwache faced considerable uncertainty about future rainfall under climate change. In none was there even a consensus on whether it

would be higher or lower than present-day averages, let alone by how much. This was a particular concern for Mombasa whose rainfall derives from a combination of systems since 61% of the 121 climate future scenarios generated for Mwache showed lower safe yields than the present-day design assumptions.

The World Bank study took a measured response to this systemic uncertainty. It distinguished between project *sensitivity* to climate change and project *vulnerability*; sensitivity refers to the possible reduction in physical “output,” while vulnerability considers the impact on economic return. In this view, even if a project’s performance is potentially sensitive to climate change, “the project’s economic worthiness is not necessarily in question.” This would include cases where the project was robust to a high degree of climate variability “and in the bargain, to climate change” so that its benefits and revenues would meet the required criteria.

“It is thus important to distinguish between climate sensitivity and vulnerability” emphasized the report, noting that both sensitivity and vulnerability would depend on the metrics used to assess performance and that factors other than climate change, such as price and demand, could be equally important.

For Mwache, although limited hydrological information was available, the design chosen was considered to have low climate risk since the river flow is considerably in excess of supply requirements and there is a low risk that the dam will not meet its target yield (World Bank 2018b).

Funding has not yet been approved, not due to climate change risks but because the financial and institutional arrangements for the dam’s management must still be resolved. Kenya’s 2010 Constitution makes water supply the responsibility of local counties. But Mombasa’s current supplies come from other counties, and the Mwache Dam itself will be built in a neighboring county.

Current proposals are to establish a regional institution that would manage all the different sources into a single system, providing bulk supplies to the major centers of four counties. This would help to address climate risks since linking different sources into a single system would increase its resilience to climate variability, maintaining supplies even if one source in the system fails. But achieving financial agreement between four counties and national government is proving to be more difficult than finding a climate-resilient dam design.

## **Windhoek, Namibia: A Climate Secure Source Using Groundwater as Storage**

Namibia’s capital Windhoek, high in the center of the arid and sparsely populated country, was established in 1892 by German colonists, attracted by the secure source of water from local springs. This groundwater resource served the growing settlement well until the 1960s when, after a series of dry years, it became obvious that additional supplies were needed.

In 1968, a “direct potable reuse” plant was built that treats wastewater for reinjection into the city’s main supply. Subsequently expanded, it can now provide 20% of the city’s potable supply. An ambitious longer-term plan envisaged a phased regional scheme, the Eastern National Water Carrier (ENWC), drawing from

Southern Africa's third largest river, the Okavango, on Namibia's border with Angola, 700 km from Windhoek. The full project has not yet been completed, but growing demand has been met by intermediate interventions, including the development of new groundwater sources on the ENWC route. Throughout this period, the city's local groundwater complemented other sources.

The use of these multiple sources varies in response to the extremely variable climate, with surface water predominating in wet seasons and greater use of groundwater and reuse in dry periods. Local aquifer recharge has recently been introduced to store surplus water in wet periods, reducing evaporative losses from the surface reservoirs and increasing system yield (Murray et al. 2018).

However, while diversification of sources provides some additional resilience to inter-seasonal climate variability, the assured yield still depends on local natural recharge supplemented by surface water imports. Drought in 2015/2016 showed that despite tightly managed demand, additional supply was needed and attention turned once again to imports through the ENWC. Although capital and operating costs appear to be prohibitive, this would substantially reduce climate risk by diversifying to an unconstrained source.

In this difficult environment, available hydrological tools have consistently provided good estimates of the volumes of water available at different levels of assurance to guide system management. The technical analysis of the recharge and storage potential of the Windhoek aquifers has also provided the basis for implementation. Although the impacts of climate change on regional precipitation and Okavango River flows are uncertain (Hughes et al. 2011), Namibia's requirement is only around 2% of the total flow, suggesting that the objections of environmentalists in Botswana, the downstream riparian, are ill-founded.

The other long-term policy option is to break the "path dependence" since Windhoek was made the country's capital 130 years ago and promote economic development in Namibia's more humid northern region rather than increase the city's water supply. Absent such a radical policy shift, the incremental completion of the ENWC is a rational approach to making Windhoek's water supply more resilient since the scope for further savings through demand-side interventions is limited.

The city's century-long hydrological history and the acute nature of the water challenges that it faces have produced a good understanding of the options available to build systems that are resilient to the risks posed by long periods of multi-season drought. As a result, if adequate financial resources are available, the strategies already adopted to manage current climate variability will enable the city to meet its needs, even under conditions of climate change.

## **Beira, Mozambique: Sea Level Rise Will Compound Existing Challenges**

Like Windhoek, the Mozambican City of Beira faces many climate-related challenges given its location which is regularly hit by tropical storms. Established in 1890 as a port and regional railway hub on low-lying land at the mouth of the Pungwe River, urban water supply is difficult because fresh groundwater is very

limited and the river's estuary is saline. While river flow is adequate to meet the city's needs, extensive saline intrusion, exacerbated by growing upstream water use, required its intake 80 km from the city to be moved further 20 km upstream. However, water quality problems continued for a nearby irrigation scheme whose intake the city had shared. While the intake could have been protected by building a weir downstream to obstruct tidal influx or storage dams upstream to maintain minimum dry season flows, these options were rejected on environmental grounds (NORAGRIC 1997).

While climate change impacts are obvious, hydrological analysis has characterized the salinity dynamics and helped to identify appropriate responses to the impact of increased water utilization and sea level rise. The immediate water management challenges have been well-characterized, and the priority is to coordinate responses to protect economic activity. However, in the longer term, the city's vulnerable location may require radical relocation rather than water management solutions.

### **Polihali Dam and the Integrated Vaal River System: Sustaining a "Problemshed"**

In economic terms, the Integrated Vaal River System (IVRS) is the most important water resource development in Southern Africa. It supplies water to around 20 million people in a region that produces almost 50% of South Africa's GDP and includes the country's administrative capital (Pretoria) as well as Johannesburg, its largest city. If its functioning is impaired by climate change impacts, the entire country will suffer.

The IVRS region lies across the watershed of the country's two largest rivers, the Orange and the Limpopo, which discharge into the Atlantic and Indian Oceans, respectively. By the 1960s, demand for water for domestic and economic purposes had outstripped the reliable flow of the main local source, the Vaal River, a tributary of the Orange River, which is also highly variable. A national policy review (South Africa 1970) recommended a system approach to identify and introduce new sources. This coincided with the emergence of new techniques to undertake the required analysis (Maass et al. 1962).

For four decades, system models guided decisions on expansion and operation (Basson and Van Rooyen 2001) that have successfully sustained water security in the expanding system. Throughout this period, the objective was to manage the extreme climate variability, with drought risk as the key metric since there was little useful information about potential climate change risks.

An important element of the system is the Lesotho Highlands Water Project (LHWP), a multiphase scheme which diverts water that flows south from Lesotho in the Orange River, northward to its Vaal River tributary. In terms of a binational Treaty, South Africa uses Lesotho territory to discharge the waters closer to the centers of demand, with considerable cost-savings. Climate variability and change are addressed in the Treaty only insofar as provision for joint action in the event of *force majeure*, covering "disturbance due to an extreme hydrological or other natural



event, including extreme drought, and affecting the delivery of water to South Africa.” Similarly, while the 1998 Appraisal Report on Phase 1B of the project (which was successfully completed in 2002) makes no explicit mention of climate variability and change, it locates the purpose of the project as “reducing drought risk” in the South African system.

The LHWP’s further phases are seen as low-risk, least-cost alternatives to augment the system’s capacity. Phase 2, the construction of the Polihali Dam on another Orange River tributary, was included in the World Bank’s “RDM study” (Cervigni 2015). As with the Mwache Project in Kenya (see above), the study considered whether alternative configurations might be less economically vulnerable if climate change reduced project performance.

Noting considerable climate uncertainty, the study suggested an alternative design could reduce the risk of financial losses due to climate change by up to 30%. This only considered assumptions about water prices and demand and not the wider societal costs of supply failure, a conservative approach since, for many societies, higher water costs are preferable to the costs of unexpected supply failures (as is formally stated in the new Cape Town water strategy (Cape Town 2019)).

Subsequent studies concluded that the Polihali Dam would meet its intended delivery targets under a wide range of climate scenarios with deficits occurring only in the very driest 16 of 122 scenarios. The IVRS also illustrates the benefits of a “problemshed”-based analysis (Mollinga 2020) which encompasses the actual physical and institutional boundaries within which water is managed not simply an individual “watershed” approach. Whereas hydrological models are based on the natural “watersheds” before human activity intervenes, water management requires models that reflect the interaction between human activities and the natural system. The IVRS shows how hydrological tools can effectively be applied to manage substantial climate variability in complex multi-basin systems.

## **Zambezi River Coordination: Drought Risks, Discount Rates, and Batoka Dam Hydropower**

The final case, the proposed Batoka Dam in the transnational Zambezi River Basin, illustrates the challenges of evaluating climate change’s impacts in a complex system and uncertain economic and institutional context. In a basin that already suffers extreme climate events, the implications of climate change for hydropower expansion are a concern. Hydropower is the main source of electricity for the riparian countries and offers further opportunities to support their socioeconomic development. The Batoka Dam project illustrates the challenges of identifying adaptive approaches that optimize the benefits that hydropower can provide while minimizing the risk.

The history of Zambezi hydropower is as much about national and regional politics as hydrology or economics. Its potential was recognized early in the twentieth century, but it was only in the 1950s that it was decided to construct the Kariba Dam, creating what is still the world’s largest dam reservoir by volume. Built

by the Government of the Federation of Rhodesia and Nyasaland, Kariba's initial installed capacity of 1300 MW was sufficient to meet the needs of the Federation. It was controversial because a smaller project could have been built on the Zambezi's Kafue tributary in Northern Rhodesia, closer to the mines that were the main centers of electricity demand. But political imperatives supported the larger project to reinforce the Federation although Northern Rhodesia, later Zambia, withdrew in 1963.

Mozambique's Cahora Bassa Dam, with an installed capacity of 2075 MW, had similar political drivers to Kariba; it used cheap electricity to reinforce the political relationship between the Portuguese colonial power and South Africa. This relationship was even shorter-lived – Mozambique became independent in 1975, just as Cahora Bassa was completed and the reservoir began to fill.

With the development in Zambia of the 900 MW Kafue Gorge Upper Dam and some smaller projects, there is now almost 5,000 MW of installed hydropower generation capacity in the basin with an average total energy production of around 30,000 GWh/year, of which 23,000 is “firm energy,” available at high reliability and very low cost, since most initial construction loans have long been repaid. This economic benefit of large water infrastructure is seldom accounted for although the resulting “path dependency” is often commented upon (Haasnoot et al. 2019).

The total energy production could be doubled to around 60,000 GWh/year through the extension of existing facilities and the construction of new dams. This would meet most of the current electricity demand of the eight riparian states although optimal production will require hydrologically informed cooperation between operators. The resilience of new schemes to climate variability and change has come under particular scrutiny as international development finance institutions consider their financial viability.

While individual projects have been assessed in some detail, it is important to understand how they would function in a future system, which includes irrigation and urban uses, under conditions of climate change. At present, evaporation from the Kariba and Cahora Bassa lakes is by far the largest “consumptive use” of Zambezi water, accounting for 85% of the 12.5 km<sup>3</sup> average “consumption”; all other uses (agriculture, urban, and industrial) account for just 1.9 km<sup>3</sup>, just 2% of the available runoff.

With the growth of population and economies, water consumption will reduce flows, impacting on hydropower production. A 2010 “Multi-Sector Investment Opportunity Analysis” (MSIOA) investigated the potential impacts of such new developments and the benefits for the riparian countries of coordinating their development plans, to reduce uncertainty about hydropower potential (World Bank 2010). The study included an economic assessment tool and considered possible climate change impacts. Its main finding was that coordinating investments and infrastructure operation could significantly increase the economic benefits compared to stand-alone project development. Beyond the hydrological uncertainties, the political challenge is to achieve an equitable sharing of the costs and benefits.

However, economic analysis is particularly challenging for investments such as water resource infrastructure which have a high initial cost but yield benefits over a

very long period. The imputed value of long-term production depends heavily on assumptions about future prices as well as the “discount rate” applied in the analysis, and there is limited consensus about the appropriate approach, not least because the choice is usually determined by policy objectives (Fankhauser and Stern 2016) in which climate change adaptation strategies are not always adequately reflected.

These issues were illustrated in the analysis of Batoka in the 2015 RDM study (Cervigni 2015). The Batoka site is on the main stem of the Zambezi, downstream from Victoria Falls and upstream from Kariba. It has limited storage and will depend on natural river flows which, although moderated somewhat in the extensive wetlands of the upper catchment, are very variable and subject to drought, making it particularly vulnerable to climate change (Harrison and Whittington 2002).

In this context, the RDM study noted that:

“In drier futures, smaller facilities yield higher net benefits, as less investment is underutilized during the dry periods. In wetter futures, larger facilities that can better take advantage of high flow periods yield higher net benefits.”

Batoka it found,

“shows significant sensitivity to climate change with up to a 33 percent decrease or a 15 percent increase in average power production.” (Cervigni 2015)

Over 30 years, the difference between the worst- and best-case scenarios was estimated at around US\$4 billion, in 2015 values, based on average energy prices in the Southern African Power Pool. But in a dry period, electricity prices would rise as all supplies would be reduced in a system that was dependent on hydropower. While in 2015 this effect was not yet evident because the region still had coal-fired alternatives, over the next five decades, coal-fired power will be constrained, and carbon taxes will increase its price, further supporting hydropower prices.

Even without these considerations, Batoka showed that “economics of projects of this type could be highly sensitive to the price of power” (Cervigni et al. 2015). Once again, it was emphasized that a project that was financially sensitive to climate change impacts was not necessarily financially vulnerable.

These economic studies are highly dependent on the discount rates chosen. The RDM study used a policy discount rate of 3% for assessing social policy objectives. But for Batoka, both the MSIOA and the RDM analyses used a “finance discount” rate of 10% (World Bank 2010) to ensure adequate financial returns to repay loans. The danger is that using present-day markets to estimate long-run prices ignores the potential increase in the value of output as a result of climate change policies, devalues the long-term benefits of cooperation, and thus does not adequately reflect the policy goals of climate change mitigation.

A final gap in these attempts to integrate policies for climate resilience more effectively fully into hydrological and economic analysis has been the failure to consider the “water use efficiency” of energy generation in the Zambezi Basin. Presently, over 10% of the Zambezi’s flow is lost to evaporation from the two

large hydropower reservoirs. Full development of the basin will not require the significant expansion of storage to manage hydrological variability, and the proposed cascade of three dams in the lower Zambezi will benefit from the hydrological security provided by the Kariba and Cahora Bassa reservoirs upstream. While the MSIOA notes with concern that the output of those projects could vary between +9% and – 13% by 2100 (World Bank 2010), it makes no allowance for value inherent in increasing “water use” efficiency by increasing the energy produced per unit of water.

These analyses of the Batoka Dam and the broader strategies to ensure optimum management of the Zambezi Basin’s waters show that the challenges of assessing the economic benefits and risks of large water investments are at least as complex as those of managing the hydrological uncertainties.

---

## **Discussion: Principles to Guide Adaptation under Uncertainty**

The cases presented illustrate the contexts within which major water resource investment decisions are taken and the limited contribution that can be made by emerging climate change science beyond the charting of the range of future uncertainty. Nevertheless, the focus on potential climate change impacts does provide useful guidance for the planners, developers, and operators of major water resource infrastructure working in “difficult hydrologies.”

### **Principles**

From these cases, some general principles can be identified that could help water resource managers to develop coherent adaptive strategies for the projects or systems for which they are responsible and assist them in communicating their approaches to their wider communities. In addition, some more operational priorities emerge that merit mention.

### **Uncertainty**

Perhaps the most important principle to emerge from the cases is that uncertainty remains the dominant feature of potential climate change impact on water resource projects. This uncertainty must be recognized and reflected in analytical approaches, strategy development, and project design. Uncertainty does not mean that stochastic methods cannot be used to detect – and project – trends. For instance, where projections of precipitation are made using multiple GCMs and the range of future uncertainties can be constrained, stochastic methods are already usefully applied. More serious challenges arise where relevant variables are not well understood or constrained as is the case with modeling future rainfall-runoff in conditions where both land cover and precipitation intensities are both poorly understood.

### **Precautionary**

The precautionary principle is usually understood to constrain developments until their impacts are understood. In the climate change context, a precautionary approach will ensure that decisions are taken in time to address possible future contingencies. This is explicitly stated in Cape Town's post-disaster water strategy which commits to make new investments which will not be used unless there is a dry period in which they are needed. This reflects the high costs imposed on the wider society by supply failure. Projects with lengthy implementation periods such as the IVRS augmentations should be implemented on a precautionary basis to avoid inefficient crisis responses that characterized many water sector investments. A precautionary approach would also introduce supply restrictions earlier rather than later although political resistance is always a factor in this – recent extreme power restrictions in Zimbabwe resulted, in part, from earlier decisions to continue generating at full capacity at Kariba, contrary to drought operating rules.

### **Path Dependence**

A concern frequently raised about water resource developments of all kinds is that they commit their societies to particular development paths and close off other options. The difficulty with these discussions is that they frequently involve larger political issues about which there is little consensus. In large measure, Windhoek's current challenges are the result of century-old colonial spatial planning decisions; the option of refocusing economic development in a more propitious location is an important alternative. Similarly, South Africa's IVRS reflects the fact that the mining economy promoted extensive development in a location with limited water resources and that coastal areas would be easier to serve. Beira's location, which also served colonial objectives, is very vulnerable to current climate, and vulnerabilities will be aggravated by climate change. But these are not issues on which water managers can determine policy. At best, they can ensure that the concerns and constraints are well understood and thus influence wider development policy debates.

### **Flexibility**

In response to uncertainty about future trends, it is helpful if strategies to meet future needs are sufficiently flexible to accommodate different futures. This principle has already been explicitly adopted in a number of the case study projects: Cape Town has identified a range of options that could rapidly be implemented in the event of a "step change" in climate; the ENCW scheme serving Windhoek can be implemented in a sequence of steps. Similarly, each step in the past and future development of South Africa's IVRS involved a choice from a set of different options.

### **System-Wide Approaches and Problemsheds**

The importance of conceptualizing and operating linked infrastructure as a system rather than as individual units brings many benefits. The values of these benefits are explicitly determined in the Zambezi Basin MSIOA but are also evident in the IVRS, Windhoek, and, at a nascent stage, Mombasa and Cape Town's new strategy.

## **Linkages**

The linkage of different sources and demand centers provides a variety of resilience benefits that can greatly assist adaptation to changing climate conditions. A benefit that could be achieved by operating Zambezi hydropower as a coordinated system is that extreme events are often not correlated. While in the south Victoria Falls and Kariba were running dry, Cahora Bassa which draws more resources from the north had to open its flood gates to manage inflows. South Africa's IVRS has already demonstrated that multiple sources provide greater assured yields than the sum of their "stand-alone" yields and Windhoek's situation is similar. Proposals for Kenya's Mwache Dam to form part of an integrated bulk system would replicate this approach.

## **Diversification**

Diversification of sources provides further important resilience benefits and should be a guiding principle for climate change adaptation. Windhoek's surface water/groundwater mix has enabled it to withstand repeated drought crises. Cape Town's recent experience highlighted the risk of relying solely on surface water supplies, which although linked all derived their inflow from a single small catchment area. Alternative sources had not been developed because, individually, their unit costs were higher, but this calculation omitted consideration of the value of additional reliability that could be gained from diversification. Care must be taken, however, to ensure that apparently diversified sources are not correlated. Thus, while reuse is a useful option, it depends on the availability of wastewater which, in crisis situations, may be constrained.

## **Storage Vs Yield**

It is widely recognized that storage is an integral element of any substantial water resource system, crucial to ensure adequate flows in dry seasons. However, it is often considered solely as part of river management infrastructure. Both Windhoek and the IVRS use strategic storage fed slowly by wet season surpluses from external sources to build a reserve that can be drawn down to provide a guaranteed supply during dry periods. This contributes significantly to their reliance against drought and other climate impacts at lower cost than would be required for the development of a new source.

## **Valuing Resilience and Reliability**

One of the features of both water and power projects in Southern and Eastern Africa is how little recognition is given to the financial and economic benefits of reliability and resilience of supply. This was forcefully illustrated by the economic losses suffered by Cape Town due to 3 years of water restrictions. But the economies of countries dependent on Zambezi hydropower have also been significantly constrained by the power cuts and rationing, and Windhoek's economic activity has been curtailed by water shortages. There is a need for more nuanced analysis of the funding of schemes that enhance resilience and reliability of supply since these values are often not included in user charges and benefit a wider public than the direct users.

---

## Operational Priorities

### **Institutional Capacity Will be Critical**

Given the intensification of hydrological analysis and decision-making, water management institutions will have to ensure that they have the capabilities to respond to the emerging challenges. This will require appropriate structures as well as the development and retention of the specialist skills, often in collaboration with specialized institutions of higher education.

### **Adequate Finance Is Required**

In all the water supply cases, current investment has been insufficient to achieve resilience to current climate variability. While this is often viewed as a problem that can be resolved by establishing effective markets for water (and also to power), the benefits of assured supplies spill far beyond the direct users to the wider society although they may only be fully realized in the longer term. This means that the full value of the water project outputs cannot be captured by prices alone and different financial arrangements are required that reflect the long-run economic benefits of secure supplies. Where water projects, notably hydropower, directly mitigate climate change by reducing greenhouse gas emissions, this should be reflected in financial terms. Current “green finance” proposals will only be of assistance if loan conditions address these structural constraints.

### **Communication to Achieve Sufficient Consensus**

Water resource development occurs to a greater or lesser extent in the public domain and is thus subject to public scrutiny and political decision. One of the challenges faced by sector managers is that they address complex issues about which public perceptions may differ widely. Water management institutions need to develop and sustain communication with their stakeholder communities to ensure their support for demand-side interventions as well as for investments on the supply side.

### **Information for “Dynamic Stationarity”**

The dynamic nature of hydrological systems under climate change means that analysis will no longer rely on standard sets of reference data from a fixed time period. The values of many hydrological variables will be changing in unpredictable ways that will require hydrological data to be updated on a regular basis. This will require an intensification of data collection and management. As one group of commentators remarked, “in a nonstationary world, continuity of observations is critical” (Milly et al. 2008).

---

## Conclusions

The principles that emerged from this review support the initial hypothesis that adaptation to climate change in the water and hydropower sector will best be achieved by following strategies that address current climate variability. All of the

principles enunciated are equally appropriate to current climate variability or climate change.

The proviso introduced by including climate change is that such interventions should recognize that uncertainties under future climate change are likely to be greater than at present. This reinforces the need for options that allow greater flexibility of approach, but it also highlights the need for a precautionary approach that will see interventions made earlier rather than later, as Cape Town found to its cost.

The idea that interventions should be made sooner rather than later will often meet opposition because it will be seen to reinforce current development trajectories and path dependence. The reason that alternative trajectories are not followed is usually that they are constrained by politics and economics. Even if the intent is to allow economic and social disruption to drive new trajectories, creating water and power crises is unlikely to create the conditions for change. Given the challenges posed by climate change, deliberate disruption of societies and economies is a high risk strategy with little certainty about the likely outcomes.

One consistent finding is that the challenges of planning, implementing, and operating large water resource schemes under difficult hydrologies will become more complex as climate change impacts intensify. While traditional hydrological tools can continue to be used, “dynamic stationarity” will require more intensive data collection, more frequent reviews and runs of models, and greater effort to communicate the findings and their implications to the wider community whose consent, trust, and support will be required for decisions. In most countries, this will require more capable organizations, better funded, staffed, and equipped than at present.

In all of this, the primary constraint to adapting to the impacts of climate change by building more resilient and less vulnerable systems will continue to be financial. A particular challenge for the water sector’s practitioners will thus be to persuade their communities that additional support for planning and managing their countries’ water will insure them against the larger costs of water and power supply failures.

---

## References

- Adler RF, Gu G, Sapiano M, Wang JJ, Huffman GJ (2017) Global precipitation: means, variations and trends during the satellite era (1979–2014). *Surv Geophys* 38(4):679–699
- Archer E, Landman W, Malherbe J, Tadross M, Pretorius S (2019) South Africa’s winter rainfall region drought: a region in transition? *Clim Risk Manag* 25:100188
- Bailey AK, Pitman WV (2016) Water resources of South Africa, 2012 Study (WR2012), WR2012 study executive summary. WRC Report TT, 683. Water Research Commission, Gezina, p 16
- Basson MS, Van Rooyen JA (2001) Practical application of probabilistic approaches to the management of water resource systems. *J Hydrol* 241(1–2):53–61
- Bloch I et al (2019) Twenty-three unsolved problems in hydrology (UPH) – a community perspective. *Hydrol Sci J* 64(10):1141–1158. <https://doi.org/10.1080/02626667.2019.1620507>
- Brekke LD, Kiang JE, Olsen JR, Pulwarty RS, Raff DA, Turnipseed DP, Webb RS, White KD (2009) Climate change and water resources management – a federal perspective: U.S. Geological Survey Circular 1331, 65 p. Also available online at <http://pubs.usgs.gov/circ/1331/>



- Briscoe J (2010) Practice and teaching of American water management in a changing world. *J Water Resour Plan Manag*
- Cape Town (2019) Our shared water future: Cape Town's water strategy, City of Cape Town
- Cervigni R, Liden R, Neumann JE, Strzepek KM (2015) Enhancing the climate resilience of Africa's infrastructure: the power and water sectors. Overview booklet. World Bank, Washington, DC
- Chahine M (1992) The hydrological cycle and its influence on climate. *Nature* 359:373–380. <https://doi.org/10.1038/359373a0>
- Chan JC (2006) Comment on "Changes in tropical cyclone number, duration, and intensity in a warming environment". *Science* 311(5768):1713–1713
- Conway D (2005) From headwater tributaries to international river: observing and adapting to climate variability and change in the Nile basin. *Glob Environ Chang* 15(2):99–114
- Fankhauser S, Stern N (2016) Climate change, development, poverty and economics (presented at The State of Economics, the State of the World conference. World Bank, Washington, DC
- Foster S, Eichholz M, Nlend B, Gathu J (2020) Securing the critical role of groundwater for the resilient water-supply of urban Africa. *Water Policy* 22(1):121–132
- Gangrade S, Kao SC, Naz BS, Rastogi D, Ashfaq M, Singh N, Preston BL (2018) Sensitivity of probable maximum flood in a changing environment. *Water Resour Res* 54(6):3913–3936
- Giorgi F, Raffaele F, Coppola E (2019) The response of precipitation characteristics to global warming from climate projections. *Earth Syst Dynam* 10:73–89. <https://doi.org/10.5194/esd-10-73-2019>
- Greve et al (2019) The aridity index under global warming. *Environ Res Lett* 14:124006
- Grey D, Sadoff CW (2007) Sink or swim? Water security for growth and development. *Water Policy* 9(6):545–571
- Haasnoot M, van Aalst M, Rozenberg J, Dominique K, Matthews J, Bouwer LM, Kind J, Poff NL (2019) Investments under non-stationarity: economic evaluation of adaptation pathways. *Clim Change*:1–13
- Harrison GP, Whittington HBW (2002) Susceptibility of the Batoka gorge hydroelectric scheme to climate change. *J Hydrol* 264(1–4):230–241
- Hegerl GC, Brönnimann S, Cowan T, Friedman AR, Hawkins E, Iles C, Müller W, Schurer A, Undorf S (2019) Causes of climate change over the historical record. *Environ Res Lett* 14(12):123006
- Herold N, Behrangi A, Alexander LV (2017) Large uncertainties in observed daily precipitation extremes over land. *J Geophys Res-Atmos* 122:668–681
- Hughes DA, Kingston DG, Todd MC (2011) Uncertainty in water resources availability in the Okavango River basin as a result of climate change. *Hydrol Earth Syst Sci* 15(3)
- Hüttl RF, Bens O, Bismuth C, Hoehstetter S (2016) Society-Water-Technology: a critical appraisal of major water engineering projects. Springer Nature, p 295
- Knutson T, Camargo SJ, Chan JC, Emanuel K, Ho CH, Kossin J, Mohapatra M, Satoh M, Sugi M, Walsh K, Wu L (2020) Tropical cyclones and climate change assessment: Part II: projected response to anthropogenic warming. *Bull Am Meteorol Soc* 101(3):E303–E322
- Kraemer BM, Seimon A, Adrian R, McIntyre PB (2020) Worldwide lake level trends and responses to background climate variation. *Hydrol Earth Syst Sci* 24(5):2593–2608
- Loucks DP, Van Beek E (2017) Water resource systems planning and management: an introduction to methods, models, and applications. Springer
- Maass A, Hufschmidt MA, Dorfman R, Thomas HA Jr, Marglin SA, Fair GM (1962) Design of water-resource systems: new techniques for relating economic objectives, engineering analysis, and governmental planning. Harvard University Press, Cambridge, Mass
- Malherbe J, Engelbrecht FA, Landman WA, Engelbrecht CJ (2012) Tropical systems from the Southwest Indian Ocean making landfall over the Limpopo River basin, southern Africa: a historical perspective. *Int J Climatol* 32(7):1018–1032
- Matalas NC (1997) Stochastic hydrology in the context of climate change. *Clim Chang* 37(1):89–101

- Milly PCD, Betancourt J, Falkenmark M, Hirsch RM, Kundzewicz ZW, Lettenmaier DP, Stouffer RJ (2008) Stationarity is dead: whither water management? *Earth* 4:20
- Mollinga PP (2020) Knowledge, context and problemsheds: a critical realist method for interdisciplinary water studies. *Water Int.* <https://doi.org/10.1080/02508060.2020.1787617>
- Moss ME, Tasker GD (1987) The role of stochastic hydrology in dealing with climatic variability. In: *The influence of climate change and climatic variability on the hydrologic regime and water resources* (Proceedings of the Vancouver symposium, August 1987), vol 168. IAHS Publ, pp 201–207. Accessed at [http://hydrologie.org/redbooks/a168/iahs\\_168\\_0201.pdf](http://hydrologie.org/redbooks/a168/iahs_168_0201.pdf)
- Muller M (2018) Lessons from Cape Town's drought. *Nature* 559(7713):174–176
- Muller M, Biswas A, Martin-Hurtado R, Tortajada C (2015) Built infrastructure is essential. *Science* 349(6248):585–586
- Murray R, Louw D, van der Merwe B, Peters I (2018) Windhoek, Namibia: from conceptualising to operating and expanding a MAR scheme in a fractured quartzite aquifer for the city's water security. *Sustaina Water Resour Manage* 4(2):217–223
- NORAGRIC (1997) Environmental assessment of the Mozambique National Water Development Project. World Bank. Accessed at <http://documents1.worldbank.org/curated/en/165791468779949188/pdf/multi-page.pdf>
- Pillay MT, Fitchett JM (2019) Tropical cyclone landfalls south of the tropic of Capricorn, southwest Indian Ocean. *Clim Res* 79(1):23–37
- Sidibe M, Dieppois B, Mahé G, Paturel JE, Amoussou E, Anifowose B, Lawler D (2018) Trend and variability in a new, reconstructed streamflow dataset for west and Central Africa, and climatic interactions, 1950–2005. *J Hydrol* 561:478–493
- South Africa (1970) Commission of enquiry into water matters, Report of the commission of enquiry into water matters, vol 34. Government Printer, Pretoria
- Strzepek K, McCluskey A, Boehlert B, Jacobsen M, Fant C IV (2011) Climate variability and change: a basin scale indicator approach to understanding the risk of climate variability and change: to water resources development and management. World Bank, Washington, DC, pp 1–139
- Trelease FJ (1977) Climatic change and water law. In: *National research council, climate, climatic change, and water supply*. National Academies, Washington, DC
- Trenberth KE (2011) Changes in precipitation with climate change. *Clim Res* 47(1–2):123–138
- Ukkola AM, De Kauwe MG, Roderick ML, Abramowitz G, Pitman AJ (2020) Robust future changes in meteorological drought in CMIP6 projections despite uncertainty in precipitation. *Geophys Res Lett* e2020GL087820
- Vaze J, Post DA, Chiew FHS, Perraud JM, Viney NR, Teng J (2010) Climate non-stationarity–validity of calibrated rainfall–runoff models for use in climate change studies. *J Hydrol* 394(3–4):447–457
- Venter ZS, Cramer MD, Hawkins HJ (2018) Drivers of woody plant encroachment over Africa. *Nat Commun* 9(1):1–7
- Vogel RM (2017) Stochastic watershed models for hydrologic risk management. *Water Secur* 1:28–35
- Woodhouse P, Muller M (2017) Water governance – an historical perspective on current debates. *World Dev* 92:225–241
- World Bank (2010) *The Zambezi River basin a multi-sector investment opportunities analysis* (Volume 1) Summary report. World Bank, Washington, DC
- World Bank (2018a) *Assessment of the state of hydrological services in developing countries*. World Bank, Washington, DC
- World Bank (2018b) *Economywide and distributional impacts of water resources development in the coast region of Kenya: implications for water policy and operations*. World Bank, Washington, DC
- Zareian MJ, Eslamian S, Gohari A, Adamowski JF (2017) The effect of climate change on watershed water balance. In: *Mathematical advances towards sustainable environmental systems*. Springer, Cham, pp 215–238

**Open Access** This chapter is licensed under the terms of the Creative Commons Attribution 4.0 International License (<http://creativecommons.org/licenses/by/4.0/>), which permits use, sharing, adaptation, distribution and reproduction in any medium or format, as long as you give appropriate credit to the original author(s) and the source, provide a link to the Creative Commons license and indicate if changes were made.

The images or other third party material in this chapter are included in the chapter's Creative Commons license, unless indicated otherwise in a credit line to the material. If material is not included in the chapter's Creative Commons license and your intended use is not permitted by statutory regulation or exceeds the permitted use, you will need to obtain permission directly from the copyright holder.





# Community Adaptation to Climate Change: Case of Gumuz People, Metekel Zone, Northwest Ethiopia

# 113

Abbebe Marra Wagino and Teshale W. Amanuel

## Contents

Introduction of the Chapter .....	2340
Description .....	2342
Information Assortment Techniques .....	2344
Adaptation Strategy .....	2345
Crop-Based Adaptation Strategies .....	2345
Livestock-Based Adaptation Strategies .....	2348
Forest Resources-Based Adaptation Strategies .....	2353
Off-Farm Activities as an Adaptation and Other Copping Strategies .....	2354
Interaction of Policy-Driven and Autonomous Community Resilience to Climate Variability Adaptation and Mitigation .....	2355
Conclusions and Recommendations of the Chapter .....	2359
Conclusion .....	2359
Recommendations .....	2360
References .....	2361

## Abstract

The effect of climate change on agricultural-dependent communities is immense. Ethiopia in which more than 85% of its population is agrarian is affected by climate change. Communities in different parts of the country perceived climate change and practice different climate change adaptation strategies. This chapter was initiated to identify adaptation strategy to the impact of changing

This chapter was previously published non-open access with exclusive rights reserved by the Publisher. It has been changed retrospectively to open access under a CC BY 4.0 license and the copyright holder is "The Author(s)". For further details, please see the license information at the end of the chapter.

A. M. Wagino (✉)

Mendel University in Brmo Project in Ethiopia, Addis Ababa, Ethiopia

T. W. Amanuel

Wondo Genet College of Forestry and Natural Resource, Hawassa University, Hawassa, Ethiopia

© The Author(s) 2021

2339

W. Leal Filho et al. (eds.), *African Handbook of Climate Change Adaptation*,  
[https://doi.org/10.1007/978-3-030-45106-6\\_244](https://doi.org/10.1007/978-3-030-45106-6_244)

climate. Data on a total of 180 households were gathered using structured and semi-structured questioners. Focus group discussion and key informant interview were also used for data collection. Climatic data from the nearest meteorological stations of the area were collected and used in this chapter. The collected data were analyzed using descriptive and inferential statistical methods. The upshot indicated that all the respondent communities experienced at least one of autonomous/self-adaptation strategies to cope and live with the impacts of changing climate. Though 33.6% complained on its accessibility and pricing, 66.4% of the respondents reviled as they do not have any awareness on improved agricultural technologies. The major adaptation strategies identified were collecting and using of edible wild plants and other forest products, hunting, renting/selling of own farm lands, livestock sell, selling of household materials/assets, collecting and selling of wood and wood products and depending on well-off relatives, using drought-resistant crop variety, changing cropping calendar, replanting/sowing, and increasing farmland size. Nevertheless, the communities are not yet fully aware and accessed to policy-driven options for climate change adaptation. Although they used different autonomous adaptation mechanisms, the households are not resilient to the current and perceived climate change. Finally, based on the findings, the recommendation is that besides encouraging the existing community-based adaptation strategies planned adaptation strategies have to be implemented: such as early-warning and preparedness programs have to be effectively implemented in the area, introduction of different drought-resistant locally adapted food crop varieties, and expansion of large-scale investment in the area has to be checked, and give due recognition to forest ecosystem-based adaptation mechanisms of the local community in the area.

---

**Keywords**

Climate change · Adaptation strategy · Autonomous adaptation · Planned adaptations · Forest ecosystem · based adaptation options

---

**Introduction of the Chapter**

The world's climate has already changed and will change dramatically. Under the no emission scenario, the average global surface temperature is predicted to increase by 2.8 °C during this century (IPCC 2007). It is now a challenge for the entire world with growth, poverty, food security, and stability implications. The demand of the hour is to adapt to the changing climate and work together to find mitigation options so that no further damage is done (IPCC 2007).

However, the impacts of existing and predicted changes in climate vary across economies. Poor countries can incur huge costs from a small deviation in climate, particularly due to their dependency on climate-sensitive sectors (Agriculture), poor adaptive capacity, lack of necessary technology, and lack of resources to deal with the stress (Seo and Mendelsohn 2008). For instance, because of significant dependence on the agricultural sector for production, employment, and export revenues,

Ethiopia is seriously threatened by climate change, which contributes to frequent drought, flooding, and rising average temperatures (Emerta 2013). Severe droughts often are followed by severe food insecurity, population dislocation, family separation, and erosion of the sociocultural fabric (Berhe and Butera 2012).

Like most parts of Ethiopia, climate change brings newer and more complicated challenges to people in Benishangul Gumuz region, having devastating implications for the peoples of the region in general and the Gumuz communities in particular (Emerta 2013). The incidence of crop pests and disease increased from time to time, the size of their forest ecosystem is threatened due to farmland and settlement encroachment by other ethnic groups (Abbute 2002). The existing socioecological system is reduced to support the Gumuz community to cope and live with the new climate stimuli as usual by traditional means. This coupled with their temporally and spatially cyclical agricultural system that involves clearing of land – usually with the assistance of fire – followed by phases of cultivation and fallow periods with the help of rudimentary labor-intensive farm tools threatened the lives of the people in the region. Particularly, the study area is highly affected by climate change and variability. As Sani et al. (2017) indicated the overall natural resources base of the region is highly degraded. Thus, people in the region are facing a variety of shocks and become vulnerable. However, the Gumuz community in the area has been responding to climate change through various adaptation strategies. However, there was no scientific study that substantiates or supports the existing adaptation strategies practiced by the Gumuz people in the area.

Identification of traditional risk mitigation and coping strategies that explicitly show elasticity of the community to existing disturbances in order to evaluate the suitability of current adaptive behaviors, as well as assess the adaptation deficit of local communities in view of increasing climate variability is very important. It would help in identifying those available adaptive measures/options that need to be built on and strengthened, as well as innovative adaptation strategies that add value to current climate risk mitigation and coping behaviors, by effectively addressing adaptation constraints experienced by communities (Berhe and Butera 2012). The knowledge of local adaptation strategies are essential to cope, adapt, and live with current and perceived extreme climate variabilities/changes through building their indigenous resilience mechanisms (WFP and FAO 2012). Therefore, knowing and building community adaptation practice is indispensable to live in the midst of the change. In addition, despite the huge potential that traditional knowledge offers for climate change adaptation, research efforts on the effectiveness and appropriateness of this knowledge have, so far, been limited. Furthermore, there are no proven approaches to integrate traditional coping mechanisms into mainstream development efforts (Berhe and Butera 2012).

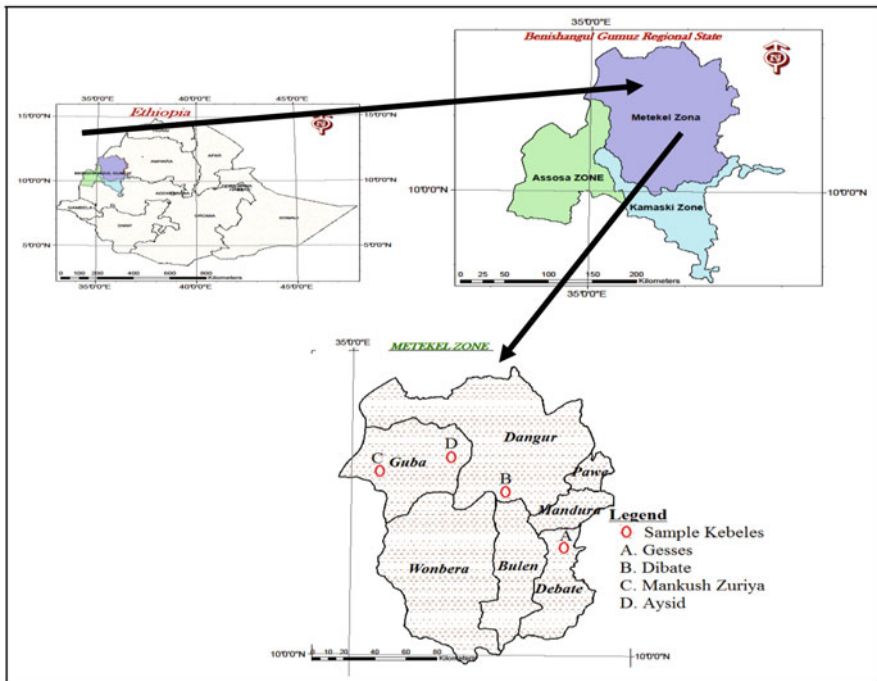
Berhe and Butera (2012) indicated that drought and climate variability are part of the natural cycle in lowland Ethiopia, and the communities do have an array of traditional coping mechanisms. Indigenous peoples are excellent observers and interpreters of change on the land, sea, and sky. Moreover, indigenous knowledge provides a crucial foundation for community-based adaptation and mitigation actions that can sustain resilience of social–ecological systems at the interdependent local, regional, and global scales. However, the ability of a community to maintain a certain level of

well-being in the face of risks depends on the resource options available to that community/household to make a living and on their ability to handle risks (Alinovi et al. 2009). Therefore, this study aimed at investigating the climate change adaptation strategies practiced by the Gumuz people in response to its adverse effects and analyzing determinants of the use of adaptation strategies in coping, adapting, and living with observed and perceived climate variability in the area.

## Description

**Location:** Metekel Zone is located in the Benishangul Gumuz National Regional State (BGNRS) (Fig. 1). The zone occupies an estimated total area of 22,028 km<sup>2</sup>. Geographically it is located between 09.17° and 12.06° north latitude and 34.10° and 37.04° east longitude. The zone encloses seven woredas/districts, namely Bullen, Dibate, Dangur, Guba, Mandura, Pawi, and Wembera. The Addis Ababa-Guba and Chagini to Wombera all-weather road provide the primary access to the area. In the present administrative context, most of the Gumuz inhabit Metekel zone to the north and Kamashi zone to the south of the Abbay/Nile River.

Agro-ecologically, the zone is mostly classified as 82% lowland (kola), 10% midland (woina-dega), and 8% highland (dega) with an average rainfall of 1,275 mm



**Fig. 1** Map of Metekel zone

per annum and an altitude range of 500–2731 meter above sea level. The Gumuz, who constitute the most numerous ethnic group of the area, mostly inhabit the lowlands in all seven districts. The total population of the zone was 276,367 (male 139,119 and female 137,248) of which 238,752 are rural setup while the remaining 37,615 are urban dwellers (BGRSDGA 2010). The land use pattern is estimated as 79% forestland, 7% cultivated land, 7% cultivable land, and 7% nonutilizable land.

The annual average temperature ranges from 16.2 °C to 32.5 °C with annual mean rainfall of 1,607.8 mm, where the annual rainfall months ranging from May to October (EARO-PRC 2000). The zone has a unimodal rainfall pattern, with an extended rainy season, from March to September. The peak rainy season is from July to August. The coldest months are December and January whereas March and April are the hottest months of the area (Esayas 2003). The mean monthly available meteorological data obtained from Ethiopian Metrological Agency for the four stations namely Bullen, Mandura, Debate, and Guba for the period of 1972 to 2013 is presented in Fig. 2.

**Vegetation:** Generally, about 55% of the total land area of the region is covered with different vegetation and forests. Bamboo, incense, and gum trees are the major forest types. Forests are important sources of construction material, fuel wood, and food, particularly for the indigenous communities (Benishangul Gumuz Region Food Security Strategy 2004). The original plant cover of the Metekel zone constitutes dense hyparrhenia, dense bamboo thickets, and scattered trees and of arboreal and thick shrub by formations along the water ways covering areas of various sizes (Dieci and Viezzoli 1992). Degradation of forest resources is increasing at an alarming rate due to various limitations. Encroachment, forest fires, absence of well-defined land use policy, and intensive resettlement programs that took place during the past government regime are some of the main causes for the depletion of natural resources in the region.

**Socioeconomic condition:** The regional economy depends on agriculture which accounts for 93.2% of the economically active population. Shifting cultivation is the major economic activity of the Gumuz community. Shifting cultivation is broadly

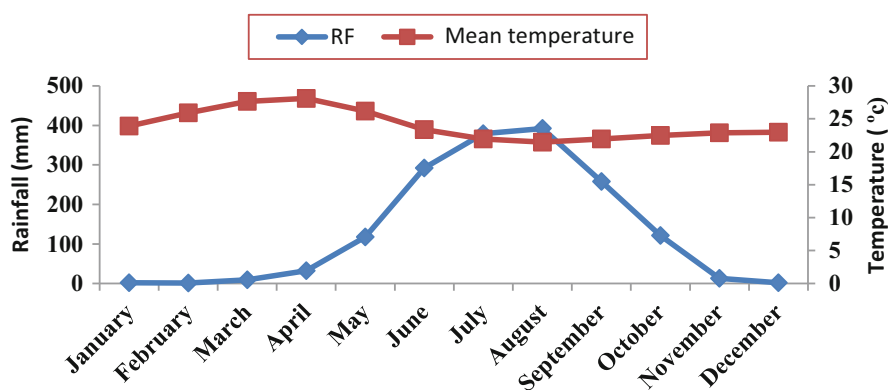


Fig. 2 Mean monthly rainfall and temperature of the study area



defined as “any temporally and spatially cyclical agricultural system that involves clearing of land usually with the assistance of fire followed by phases of cultivation and fallow periods. The subsidiary livelihood sources include livestock raising, gathering wild foods, fishing, honey production and collection, traditional gold mining, hunting, handicrafts, petty trade and charcoaling” (Anonymous 2004, 2011).

Rudimentary labor-intensive farm tools usage, prevalence of crop diseases, pests and weeds, declining soil fertility, inadequate use of improved inputs, erratic rainfall, human diseases such as malaria, poor rural infrastructure facilities like market and road, absence of credit services, and poor working culture of the communities largely due to use of labor-intensive farm tools and low awareness resulted very limited crop production and productivity in the area.

---

## Information Assortment Techniques

A multistage sampling technique was used to collect information/data. In the first stage, out of the seven woredas (districts) where the Gumuz ethnic groups predominantly live in the zone, three woredas were purposively selected to include different attributes. The Gumuz community lives almost in the same agro-ecological zones in all woredas. Then within the zone Debate, Dangur, and Guba woredas were selected for this study. In the second stage of sampling, kebeles within the selected woredas were selected according to settlement patterns, farming practices, crop varieties, socioeconomic aspects, climate problems, and disasters besides biophysical features.

Accordingly, Gessess kebele consisted of 260 households from Debate woreda, Debate kebele consisted of 228 households from Dangur woreda, Aysid consisted of 244 households, and Mankush-zuriya kebeles consisted of 107 households from Guba woreda were selected. The numbers of farmers in each sample peasant association were different, specific numbers of respondents were selected with probability proportionate to size (PPS) random sampling technique to ensure representativeness of the population. Consequently, more than 20% sampling intensity was used from each kebele, accounting a total of 180 sample households and interviewed.

**Data collection:** Both primary and secondary sets of data were collected. The primary data were collected by using tools of household survey (using structured questionnaire and in-person interview), focus group discussion (FGD), and key informant interview (KII). The valuable secondary data were also obtained from various sources including previous scientific studies and reports from Zonal level agricultural department and other concerned organizations. In addition, the climate data (rainfall and temperature data) was obtained from the National Metrology Agency for the year 1972–2013.

**Examination:** SPSS statistical software (IBM-SPSS software; version 20) was used throughout the statistical analysis. Both qualitative and quantitative techniques were used to inquiry and presented in the forms of interpretations, comparisons, and arguments. In addition, the quantified information collected using PRA (Participatory Rural Appraisal) tools also presented in figures and percentage. The quantitative analyses made use of all descriptive, correlation, and inferential

statistical techniques. The descriptive statistical techniques applied in the study include percentages and graphs. Correlation statistics was used to determine the associations of the major autonomous adaptation strategies, major determinants of community resilience in coping, adopting and living with the impacts of current and perceived climate extreme events, and the interaction of extracted community resilience building blocks presented in the form of tables.

In all cases the significance of the result was also tested using statistical T-test and chi-square Pearson test in determining the p-value to define the significant variation of the obtained results among sample woredas and relative wealth categories of respondent households.

---

## Adaptation Strategy

### Crop-Based Adaptation Strategies

Almost all (98.9%) of the respondent households practice rain-fed agriculture. Out of 180 respondents only two of them, 1.1%, reported to have owned an irrigated land of 0.5 hactar each. The major crop-based autonomous adaptation options include: (1) extension of fallowing period, (2) delaying of sowing period and/or sowing two to three times on a specific plots of land for a single harvest following availability of moisture, (3) adoption of hardy and early maturing crops varieties, and (4) increase farm land size (Table 6).

About 75% of the respondents use fallowing crop production system of farming practice (Table 1). Plots are cultivated for 1 or 2 years, then left to recover to woodland by lying fallow for 5 or more years. It is a system which involves clearing of irregular plots at some distance from the village by cutting and burning off trees and shrubs prior to tilling with the hoe. The FDG and KII participants indicated as farmers extend their fallowing period as an option to the effect of climate variability. They perceived that extending fallowing period will increase moisture holding capacity and soil fertility of the land which further increase productivity of the land through reducing weed and pest/disease infestation. The contribution of fallowing in reducing crop weed and pest/disease was mainly reported in Dangur woreda. It is also indicated by Nyong et al. (2007) as natural mulches moderate soil temperatures and extremes, suppress diseases and harmful pests, and conserve soil moisture. However, the practice may increase emission of GHG (Green House Gases) since it involves clearing and burning of forest covers. Though the advent of chemical fertilizers usage is highly encouraged by local level government, local farmers largely depended on organic farming with zero tillage practice which is also capable of reducing GHG emissions.

The FGD participants in GubaWoreda of both Mankush-zuriya and Aysid kebeles testified that almost 100% of the farmers changed the variety of their provenance local crop seeds as an option of adaptation to climate change to lead their subsistence life. As a result of increasing trends of temperature which is subjected to increase the drying period of the season and declining effects of rainfall amount, they forced to

change the variety of their provenance crop seeds, locally named as “Bobbe/yeshenkuit” into “Tirkuwash,” a sudan crop variety (both crops belong to sorghum bicolor crop type), because of its adaptation to drought and having short period of time on field for harvesting than the local variety. However, they also explained as they preferred the local variety of their own because of its test difference and ease of management on field. During the discussion, it was understood that the local varieties were not easily managed to get and visualized. Besides all the respondent households and FGD participants indicated to sow crop seeds at least two to three times per a single season on a specific plots of lands due to irregular rainfall in the area.

Usage of diversified crop production system through mixed cropping (intercropping) is also mentioned by FGD participants and by 66.6% of respondent farmers (Table 1). This also includes planting more drought-resistant crops with traditionally adopted early-maturing varieties, for example, the farmers sow pumpkin with other lowland crops and start using of its leaf early at the time when it starts emerging leaf. Furthermore, 93.3% of the respondents have a plan to increase their farm land. The factor that drives respondent households to increase their farm land was mainly due to climate variability that induced food insecurity-related issues (Table 2). As indicated in Table 2, 69.9% of the respondent indicated shortage of

**Table 1** Agricultural crop production system

Production system	Yes		No	
	Count	%	Count	%
Intercropping production system	120	66.6	60	33.4
Crop rotation production system	108	60	72	40
Fallowing production system	135	75	45	25

**Table 2** Factors that drive households to increase their farmlands

Description			Factors				Total
			Low production	Low market prices	Food insecurity	Other (specify)	
Woreda	Dibate	Count	36	0	16	4	56
		% within Woreda	64.3	0	28.6	7.1	100
	Dangur	Count	57	0	2	0	59
		% within Woreda	96.6	0	3.4	0	100
	Guba	Count	30	2	29	0	61
		% within Woreda	49.2	3.3	47.5	0	100
Total		Count	123	2	47	4	176
		% within Woreda	69.9	1.1	26.7	2.3	100

crop production both for market and household consumption, while 26.7% depicted the existence of food insecurity in general. The rest 2.3% of the households also reported as others (to support their dependents, ancestors).

To this end, as it was reported by one of key informant interviewee at Dangurworeda, and later confirmed by development agents of the surveyed kebeles, during the critical food shortage months the Gumuz farmers have been taking “one quintals of maize to return two quintals of sesame (locally named as Selit), the known cash crops of the area, aftershocks within the same harvesting year,” unless he/she is forced to give a reasonable land of his/her own to the guy so that he/she can plow until return the amount of sesame as promised. This is obvious that it affects the capacity of the community to adapt to the current impacts of climate variability or changes, though they use the system to save their life when the family face a food shortage induced by variation of rainfall.

Although all of the respondents are engaged in rain-fed agricultural practice, a limited effort made as a planned adaptation option. In this regards, Table 3 shows that 63.8% of the respondents do not used any kinds of agricultural inputs to maximize their production from agriculture sector, while the rest used either of agricultural inputs indicated in Table 3. As it was reported by KII the overall improved agricultural practice by the Gumuz people in the area are still at demonstration stage.

Table 4 also showed that almost more than 67.5% of the surveyed households did not have both access and potential to use agricultural inputs with no significance

**Table 3** Improved agricultural inputs utilized/practiced or not (in %)

Improved agricultural inputs	Debate		Dangur		Guba		Total	
	Yes	No	Yes	No	Yes	No	Yes	No
Inorganic fertilizer	7	93	10.2	89.8	6.7	93.3	8	92
Improved seeds	7	93	3.4	96.6	35	65	15.1	84.9
Organic fertilizer	10.5	89.5	5.1	94.9	23.3	76.7	13	87
Herbicides chemicals		100	25.4	74.6	1.7	98.3	9	91
Do not used any forms of agricultural inputs	83.9	16.1	57.6	42.4	50	50	63.8	36.2

**Table 4** Respondents having access and potential to use agricultural inputs or not

Surveyed woredas		Yes	No	Total
Dibate	Count	11	43	54
	%	20.4	79.60	100
Dangur	Count	23	35	58
	%	39.7	60.3	100
Guba	Count	21	36	57
	%	36.80	63.2	100
Total	Count	55	114	169
	%	32.5	67.5	100

difference among surveyed woredas and/or kebeles, beside low level of the community awareness and skills on application of different improved agricultural technologies as depicted by FGD participants. The rest 32.5% appreciated their own autonomous means adaptation options. Among those who use improved agricultural inputs 36.2% are also reported that they use the inputs only for cash crop production not yet used for food crop production purpose because of its price. Also they are satisfied in using the existing natural soil fertility in the area with no significance difference among sample woredas and respondent wealth category, as reported. Hence, revisiting of promotional approaches/system in the way that the Gumuz community awareness level and capacity developed to adopt and use introduced technologies as a planned adaptation option to boost the return from crop production in the area which further builds the resilience of the community to adapt to the impact of current and perceived climate extremes.

### **Livestock-Based Adaptation Strategies**

In addition to agricultural crop farm, 84.1% of the respondent households have at least one type of animal/livestock husbandry including chicken, with no significant difference among study woredas of sampled kebeles. The household survey and FGD verified as the farmers in the surveyed areas use a mixed farming system besides their dependency on the forest ecosystem to sustain their livelihood. Anonymous (2004) also indicated livestock plays a big role in the livelihood of the community in the areas.

However, 50.3% of respondents indicated the declining trends of livestock production since the last 5 years which is attributed to shortage of feed (73.6%) and stealing of animals (24.7%). Also 35.8% of feed shortage perception was associated with shortage of rainfall. In this regards, 97.2% of respondents use communal grazing land feeding system while 2.8% feed through hay/silage preparation/zero grazing by their own traditional means. FGD and KII indicated that except Debate woreda where stealing of animals was worthily mentioned and looks after their cattle, the rest sends their cattle to areas where permanent water flows exists, just like wild animals. The cattle return to the village at the beginning of June where new grass started to sprout out. Consumption of milk and milk products including eggs are not common for Gumuz people. However, almost all respondents reported they use selective keeping of livestock like goat and donkey since they have a capacity to adopt climate extremes through feeding leafs of bushes and other by-products of prepared local drinks, respectively. The discussion participants reported they use traditional medicine for their animal health care during their visit periodically.

As a means of adaptation options 91% of respondents indicated that they sell animals to adopt with the current climate change-induced stress Table 6. The correlation test results in Table 5 indicated selling of animals negatively correlated with hunting of wild animals and renting/selling of his/her own farm lands. This indicates if a household sells their animals their dependency participation/engagement in hunting of wild animals and renting/selling of his/her

**Table 5** Pearson correlations of autonomous adaptation strategies/parameters estimate

Correlations	Pearson correlation	Collecting edible wild plants	Collecting/ hunting wild animals	Getting support from better-off relatives/freely	Renting/ selling of his/her farm lands	Selling of animals	Selling of available household materials and/or equipments	Collecting and selling different wood and wood products
Collecting edible wild plants		1	0.414 <sup>a</sup>	-0.029	0.236 <sup>a</sup>	0.085	0.071	-0.086
	Pearson correlation		0.000	0.353	0.001	0.131	0.176	0.127
	Sig.		177	177	177	177	176	177
Collecting/hunting wild animals		0.414 <sup>a</sup>	1	0.069	0.377 <sup>a</sup>	-0.055	0.035	-0.045
	Pearson correlation		0.000	0.179	0.000	0.235	0.321	0.277
	Sig.		177	177	177	177	176	177
Getting support from better-off relatives/freely		-0.029	0.069	1	0.115	0.107	0.333 <sup>a</sup>	0.234 <sup>a</sup>
	Pearson correlation		0.069	0.179	0.064	0.078	0.000	0.001
	Sig.		177	177	177	177	176	177
Renting/selling of his/her farm lands		0.236 <sup>a</sup>	0.377 <sup>a</sup>	0.115	1	-0.030	0.089	0.011
	Pearson correlation		0.377 <sup>a</sup>	0.115	0.064	0.078	0.000	0.001
	Sig.		177	177	177	177	176	177
Selling of animals		0.085	-0.055	0.107	-0.030	1	0.234 <sup>a</sup>	0.281 <sup>a</sup>
	Pearson correlation		0.235	0.078	0.344	0.001	0.000	0.000
	Sig.		177	177	177	177	176	177
Selling of available household materials and/or equipments		0.071	0.035	0.333 <sup>a</sup>	0.089	0.234 <sup>a</sup>	1	0.307 <sup>a</sup>
	Pearson correlation		0.321	0.000	0.120	0.001	0.000	0.000
	Sig.		176	176	176	176	176	176
		176	176	176	176	176	176	176

(continued)

**Table 5** (continued)

Correlations	Collecting edible wild plants		Collecting/ hunting wild animals	Getting support from better-off relatives/freely	Renting/ selling of his/her farm lands	Selling of animals	Selling of available household materials and/or equipments	Collecting and selling different wood and wood products
	Pearson correlation	Sig.	N					
Collecting and selling different wood and wood products	-0.086	0.127	177	0.234 <sup>a</sup>	0.011	0.281 <sup>a</sup>	0.307 <sup>a</sup>	1
				0.001	0.444	0.000	0.000	
				177	177	177	176	177

<sup>a</sup>Correlation is significant at the 0.01 level (1-tailed)

**Table 6** Autonomous adaptation strategies used by the surveyed households

S. no.	List of adaptation options used	Dibate		Dangur		Guba		Total		P-value		Among wealth category
		No	Yes	No	Yes	No	Yes	No	Yes	Among woredas		
1	Collecting edible wild plants and nontimber forest products	0	32	0	33.3	2.3	33.8	2.3	97.7			
2	Collecting/hunting wild animals	2.3	29	0.6	32.8	9	26	11.9	88.1			
3	Getting support from better-off relatives/freely	8.5	26	18.1	18.3	7.3	30.1	33.9	74.4	$P<0.000$		
4	Borrow food, or rely on help from a relative/to be back in labor, in cash/in kind after shock	9	23	23.7	9.6	5.6	29.4	38.4	66.6	$P<0.000$		
5	Renting/selling of his/her farm lands	10.7	21	5.6	27.7	13	22	29.4	70.6			
6	Migrating for seasonal labor selling	17.1	14	29.7	4	15	19.4	62.3	37.7	$P<0.000$		$P<0.008$
7	Migrating to other area	19.2	12	32.2	1.1	28	7.3	79.1	20.9	$P<0.000$		
8	Selling of animals	2.3	29	6.2	27.1	0.6	34.5	9	91	$P<0.004$		
9	Selling of available household materials and/or equipments	8.5	23	15.3	17.6	5.1	30.1	29	71	$P<0.000$		
10	Charcoal production and selling	3.4	28	30.1	2.8	23	11.9	56.8	43.2	$P<0.000$		
11	Fuel wood collection and selling	4	27	26.7	6.8	4	31.2	34.7	65.3			
12	Collecting and selling different wood and wood products	4.5	27	18.6	14.7	1.1	33.9	24.3	75.7	$P<0.000$		$P<0.005$
13	Rely on less preferred or less expensive food	12.4	19	15.8	17.5	1.1	33.9	29.4	70.6	$P<0.000$		
14	Purchase food on credit	28.8	2.8	27.7	5.6	19	16.4	75.1	24.9	$P<0.000$		$P<0.000$
15	Consume seed stock that will be needed for next season	15.8	16	18.6	14.7	2.8	32.2	37.3	62.7	$P<0.000$		
16	Gather wild foods, gather "famine foods," or harvest immature crops	7.9	24	6.8	26.6	7.9	27.1	22.6	77.4			
17	Send household members to eat elsewhere	20.3	11	29.4	4	15	20.3	64.4	35.6	$P<0.000$		
18	Send household members to beg	27.7	4	31.6	1.7	27	8.5	85.9	14.1			

(continued)



Table 6 (continued)

S. no.	List of adaptation options used	Dibate		Dangur		Guba		Total		P-value	
		No	Yes	No	Yes	No	Yes	No	Yes	Among woredas	Among wealth category
19	Limit portion size at mealtimes	7.3	24	22	11.3	0.6	34.5	29.9	70.1	$p < 0.000$	$p < 0.000$
20	Restrict consumption by adults in order for small children to eat	12.4	19	25.4	7.9	0.6	34.5	38.4	61.6	$P < 0.000$	$p < 0.008$
21	Reduce number of meals eaten in a day	6.2	25	18.8	14.8	0.6	34.7	25.6	74.4	$P < 0.000$	$P < 0.000$
22	Skip entire days without eating	28.8	2.8	22	11.3	22	13	72.9	27.1	$P < 0.002$	$P < 0.002$
23	Other specifies	23.5	0	58.8	5.9	0	11.8	82.4	17.6		

farm land decrease and vice versa. On the other hand, selling of animals positively correlated with other autonomous adaptation option indicated in Table 5 where it is associated with selling of available household materials or equipments and collecting and selling of different wood and wood products are significant at the 0.01 level (Table 5). This depicted that livestock productions are playing a crucial role in coping the impact of climate change and building the resilience of the farmers in the area.

## **Forest Resources-Based Adaptation Strategies**

The main autonomous coping responses of the household to food shortage caused by drought, erratic rain, and others are presented in Table 6. Most of the respondents (64.8%) indicated that climate stress/shock in the study area resulted in declining of crop and animal production. About 53.5% of the respondents revealed that decline of crop production was associated with variation of rainfall distribution and amount beside other factors. At the time of stress, due to climate change effects, the respondents stated that they are engaged in hunting (85.1%), collecting wild edible plants, and other forest products (88.1%).

On top of this Table 6 it specified that 65.3%, 43.2%, and 75.7% of respondents also engaged on fuel wood selling, charcoal making, and collecting and selling of wood and wood products, respectively. Except collecting and selling of fuel woods which was the same among all woredas and respondents wealth category, the rest of the two (charcoal making and selling of different wood and wood products) have a significant difference among surveyed woredas and wealth category of the respondents. Charcoal making and selling was reported only in Debate woreda. Meanwhile, the large number of respondents from Guba and Debate woreda also conveyed that they engaged on selling of different wood and wood products. In addition, the Pearson correlation test of the major autonomous adaptation strategies indicated in Table 5 shows the existence of strong negative correlation among selling of different wood and wood products with collection of edible wild plants and other forest products, and hunting of wild animals. This may be because of reduced forest resources both in coverage and in its composition to collect edible wild foods and to conduct hunting in Debate and Guba woredas which may be attributed to the existence of large-scale agricultural investment and population pressures than Dangur woredas. As a result, it is also estimated by FGD participants in Debate woreda that the existing tree species reduced by about 40% as an expense of the lost Bamboo species. Moreover, 16.5% of respondents depicted that they compensate any low local market prices, if any, by increasing exploitation of nontimber and timber forest products (NTFP and TFP) besides expanding their agriculture farm land.

Hence, forests are playing a pivotal role in climate change adaptation through building their adaptive capacity which further contributes towards building the resilience of the community in the study area beside its climate change mitigation

role. Therefore, provision of due attention in this sector is indispensable to adapt to the current and perceived impacts of changing climate in a sustainable way.

### **Off-Farm Activities as an Adaptation and Other Coping Strategies**

Besides crop, livestock, and forest resource-based adaptation strategies mentioned above, 65.5% of respondents also depend on loan from relatives, 70.6% on renting/selling own farm land, and 22.3% involve in different handcrafts and local beer making to cope, adapt, and live with the impacts of climate change in order to survive their family as another option. The FGD result also indicated that the households engaged on labor selling and renting their farm lands as a means of alternative to pass the food shortage gaps or to live with unexpected happening of climate-induced shocks/stress in the area.

However, it was indicated by respondents that selling or renting of own farm land for the long period of time may affect the monetary values of that land after a long period of time. Likewise, the existence of this problem was also reported by the FGD and KII participants, they stated that when the Gumuz farmers rent their own lands to other ethnic groups who have an experience in oxen farming they use the land intensively to maximize its return. However, they indicated that it is very difficult for Gumuz farmers to manage the land after renting since its pest and weed infestation increase which requires additional cost and labor to maximize the production to which the Gumuz do not have the experience and capacity to afford. Thought it do not have a legal ground, the Gumuz farmers prefer selling of their lands than renting; this may affect their adaptation ability after a long period of time.

In addition, 74.4% of respondents depend on their better-off relatives to sustain their subsistence life (Table 6). As indicated in the Table 5, looking after relatives for support is negatively correlated with collecting edible wild plants and positively correlated among selling of available household materials or equipments and collecting and selling different wood and wood products with 0.01% significant level. From this it is understood that farmers seek for support from their relatives after exhausting edible wild plants and actively engaged on selling of his/her household materials, and labor-intensive wood and wood products. The practice may have resulted in loss of self-esteems and ability besides affecting the capacity of their relatives too. The correlation result in Table 5 also revealed that the community considers hunting of wild animals as an alternative means even if it does not replace the food demands of the community in the area. In consistence with the declining trends of vegetation cover as a result of expansion in large agricultural investment, currently it is not easy for the community to hunt wild animals as they accustomed before, though it is positively correlated with other autonomous adaptation options except getting support from better-off relatives and collecting and selling of different wood and wood products.

Selling of available household materials/equipment positively correlated with collecting and selling different wood and wood products ( $P < 0.000$ ). Also getting support from better-off families affirmatively correlated with collecting edible wild

plants and other products, while most of the others correlated negatively. This correlation synergy results indicated that most of “the traditional/autonomous adaptation strategies are not a choice of the community rather it is a means of survival.” For instance, the correlation selling of animals are not significantly correlated with collecting edible wild plants and selling/renting of farm lands as indicated in Table 5. This means, when they sell animals and get money to adapt/cope with observed shocks/stress at a given time the household may be not encouraged in collecting of edible plants, hunting, and others. Hence, the correlation result indicated that the community experienced for ages traditional/autonomous adaptation strategies mentioned that are not a choice of the community, rather a means of survival without which their survival is in question. Hence, this analysis result accentuates the importance and timing of introducing the planned adaptation/copping strategies that influenced the community both by the government and/or other development actors.

However, since the community depends on their traditional means for ages, it is very difficult to influence them overnight to accustom the planned/policy-driven strategies; for instance, to transform from hoe farming to oxen farming or other alternative mechanism. Hence, the current situation of the community and the survey findings vigilant the policymakers to consider the subsistence means of the community while making a decision at macro-level to utilize the forest land of the area by providing for large-scale investors, where the life of the community depends on, to bring a better development options in the country as a whole.

---

## **Interaction of Policy-Driven and Autonomous Community Resilience to Climate Variability Adaptation and Mitigation**

The Gumuz community has been excluded from much of the social and economic activities of the main stream society (Abbute 2002). However, there seem to be some changes in this regard in recent years. In view of this, 47.5% of the respondent households are not aware of having the right to get access to social services. This is despite the fact that our further probing in FGDs and individual interviews showed that their participation does not actually demonstrate equality in the complete sense of the term in any forms of development activities conducted in the area. The development effort seems a top-down approach which overlooks the consent of the beneficiary community. This may have questioned the ownership issues of the development effort under ways in the area. Supporting this statement, Sperling and Szekely (2005) revealed that striking the right balance between top-down command-and-control approaches offer stability over the short term but reduced long-term resilience.

Although limited, improved agricultural practices and technologies, and resettlement programs are the major planed/policy-driven adaptation options promoted to build the resilience of farmers in the areas. Hence, its interaction with community-based adaptation option has discussed.

**Agricultural Practice and Technologies:** It was generally agreed that the policy responses to climate change should support and enhance indigenous resilience (UNISDR 2009). In this regards, only 42 households in Guba (both in Mankush and Aysid kebeles), 37 households in Dangur, and 20 households in Debate woredas of surveyed kebeles were reported as they used improved agricultural technologies since the surveyed period. In this regards, Table 7 shows comparison of the actual observed number of farmers started using of agricultural inputs and animals for farming activities with the total number of households in the sample kebeles. This indicated that only a very small number of farmers, 7.7% in Debate, 16.2% in Dangur, and 15.4% in Guba, started using animals for agricultural farm activities. Hence, the result suggest that revisiting of promotional approaches/system in the way that the Gumuz community awareness level and capacity developed to adopt and use introduced technologies as a planned adaptation options to cope, adapt, and live with the observed and perceived climate variability–induced shocks/stress is indispensable.

In addition, capacity building trainings and awareness rising programs were reported as key intervention underway by the government to improve farmers' perceptions towards improved agricultural technologies. However, 66.4% of the respondents reported as they lack awareness on the importance of agricultural technologies, while 11.2% complained unfairness of the available inputs and 15.4% appreciated the existing natural soil fertility than using the artificial once. FGD participants also indicated that the community also lacks their needs of improved and drought-resistant food crop varieties that require short period of time. In this case the existence of mismatching between the needs of the community to adapt the impact of climate change and the promoted agricultural technologies is acknowledged. For instance, the community needs locally adaptive drought resistance and high-productive food crop varieties than inorganic fertilizer. Indeed, the FGD and KII participants believe that the voices of the community are often unheard. Also they complained about the price of agricultural inputs, which they attributed to difficulties in reaching the poor community groups which is highly vulnerable and/or susceptible to the impacts of climate-induced shocks due to their low adaptive capacity.

Kebele/local-level development agents believed that although a limited effort has been exerted by nongovernmental organization, namely Canadian Physician for Aid

**Table 7** Proportion of households who participated in new agricultural technologies

S.no	Name of sampled woreda	Sampled kebele	Total household	No of household participated in new agricultural technologies (Agricultural inputs)	%
1	Debate	Gessess	260	20	7.7
2	Dangur	Dibate	228	37	16.2
3	Guba	Mankush zuriya	107	14	13.1
		Aysid	224	37	16.5

and Relief (CPAR) and World Vision (WV) Ethiopia to change the deep-rooted saving culture problem of the Gumuz community in the area through organizing them into saving and credit groups, the involvement of local-level government structure is very limited to scale up this effort besides development of their awareness at all level to diversify means of their livelihood. On top of this, among introduced major agricultural technologies only 78% use veterinary services followed by pesticides (15%) and 6.6% ploughing by animals (Table 8). Though maximum efforts have been made by development actors at all level, only 6.6% used ploughing animals for farming practices.

Most of policy-driven agricultural technologies require intensive farming which do not fit with traditional Gumuz farming practice. They alleged that if they produce agricultural crops more than 2 years on a given plots of land continuously the weed and pest infestation increase which requires additional labor and cost. This also needs ploughing by animals than hoe farming where the Gumuz farmers do not have experience, capacity as well as willingness to adopt. In addition, using of a given plots of land for more than 2 years (for 3 and 4 years) requires seed every year which may also costs the farmers every year. Traditionally, once they sow on a given plots of lands they harvest for consecutive 2 years especially of food crops (sorghum). Although it needs further research, the practice seems to have a considerable role in reducing GHG emission through carbon sequestration.

Metekel zone administrator confirmed the existence of strong tension in breaking the traditional means and adopting the new practice. Shifting of hoe farming to animal farming is not achieved overnight. Enforcement of the existing regional land use polices to implement accordingly in the way that it reduces the existing population pressure on forest resources needs to be capitalized. Also the existence of illegal land grabbing in the zone which were initially entered along with legally registered large-scale agricultural investors as a daily laborer worker needs to be checked and corrected. Currently at local government level they considered the investors as a major cause for devaluation of the traditional Gumuz community means of land management and for the observed poor working culture of the indigenous/Gumuz community. The illegal land holders encourage/initiate the Gumuz people to sell, rent, and provide their lands for share cropping than own farm. In addition, the administrator acknowledged as one of the bottlenecks of providing lands for large agricultural investment in the area. Currently the Gumuz communities especially the youngsters considered themselves as investors, predominantly in Debate and Guba woredas as witnessed by FGD participants.

**Table 8** Major agricultural technologies introduced and used by the farmers

Technologies	Yes		No	
	count	%	Count	%
Veterinary service	135	78	38	22
Pesticides	26	15	147	85
Artificial insemination	2	1.2	171	98.8
Ploughing by oxen/tractor (Agricultural implements costs)	41	6.6	57	93.4

Because socially in their community they have a right to use their clan land; but currently they started selling, renting, and give for share cropping their clan lands which is large in size/coverage even though traditionally land is not sold under any circumstances either inside or outside the clan of the Gumuz community (Patrick Wallmark 1981).

Hence, the traditional clan land management systems of the Gumuz community is changing with time which may be as a result of population pressures and the extreme climate conditions that forced the highlander immigration to find an alternative means of fulfilling their basic needs and/or provision of forest lands for large-scale agricultural investment.

To this end, it is noted that the community started questioning the government to hear their voice and close a reasonable size of forest land areas for the community. "Head of agriculture and rural development office of Guba woreda confirmed that the land allocation and provision systems for large investors in the area were not considering the local context. Also pointed as, the woreda/district officials are exerting their maximum effort in collaboration with zonal and regional government to create a situation in which the local voice should be heard and considered during allocation of large forest lands for investment works. As an adaptation option, promotion of technology transformation from the investor to farmers, establishment of local-level research centers, introduction of appropriate veterinary services, income source diversification through appropriate management of livestock's, and promotion and development of appropriate plan in which the available water sources like Beless, Ayma, and Abay rivers used for irrigation as a major development directions were set at woreda level."

Generally, all policy-driven technologies seem to improve the knowledge and capacity of the community to cope, absorb, and adopt with stress and shocks beside its contribution to increase emission from all land use practices unlike the traditional means. Its rate of promotion is overwhelmed by the current rate of climate variability-induced impacts that threatened the life of the Gumuz people in the areas.

Resettlement: With the objective to introduce improved technology and infrastructure for ensuring food security and to change the lifestyle of the Gumuz ethnic groups, villegization program was initiated by the government and implemented in the area since the year 2012. Most of the farmers were resettled into centralized villages where the water is available or planned to be accessed. However, the FGD participants testified that the community prefers to live in their traditional villages as practiced by their ancestors. Hundred percent of the resettled households whispered as they got no remittance payments made to the community for the resettlement programs. They also mentioned as they face difficulties in identifying what and where to get their needs from forest resources in the new areas since there is no other alternative options to support their ways of life. They also mentioned reduction of forest resources as a result of pressures induced by resettlement program that threatened their life. They reported that women sometimes leave newborns at home to go the whole days for collecting forest products; otherwise there will be no food for the family as a whole. Women were also got difficulties in getting resources to produce different handicrafts, the important economic activity in the area, especially for the women, both for home use and market. Besides its importance in accessing basic socioeconomic services, the program seems

as it threatened the community traditional means of coping and living with the current and perceived climate variability-induced shocks/stress. In this regard, they are urging revisiting of the program and development of strategic plans that accommodate the interest of the community in supporting their ways of life means in their new areas.

The three key issues that would affect the successful implementation of the planned/policy-driven adaptations options which need the attentions of policymakers when making decision to use the area for other development purpose are identified. The first was the level of technical assistance, given the limited experience and lack of local language knowledge of the government extension workers in the study zone. As a consequence, extension agents do not have skills to train and influence farmers on the adaptations that could be implemented now, or to provide adequate technical support for routine agricultural production practices. Technical assistance from NGOs and community-based extension emphasize that farmer-to-farmer knowledge exchange supported by targeted technical assistance is needed to address the lack of formal extension services.

The second was poor working and saving culture of the community. Since they are highly dependent on forest and forest products they do not have even storage facility for their produces. They store in the farm at field and outside of their village. Also the mens do not have commitment to be engaged on agricultural farm activities alone with his family but women. Their farm activities have been conducted through a self-help group, locally named as “debbo.” Debbo requires preparation of local drinks the self-help members to conduct agricultural activities for debbo owner. All arrangement and preparation of necessary materials for debbo is the duty of women in the community. Especially during clearing of forest lands, weeding, harvesting, and threshing of crops debbo is must. The farm land size and amount of crop harvested will be also determined by the number of the debbo that a given household would be managed.

Finally, Gumuz farmers lack experience in oxen/animal farming and conducting intensive farm operations besides lack of capacity to have animal or any other small technologies for agricultural farm operation purpose. Malone (2009) indicated that the adaptation process requires the capacity to learn from previous experiences to cope with current climate, and to apply these lessons to cope with future climate, including surprises. Hence, introduction of planned/policy-driven adaptation strategies based on the existing community-based adaptation options that influence the community is indispensable to cope and adapt with extreme weather- and drought-induced shocks/stress in a sustainable way through building their resilience. In this regard, any policy-driven adaptation options that address the above-mentioned key elements are required to improve the adaptive capacity of the Gumuz community in the area.

---

## **Conclusions and Recommendations of the Chapter**

### **Conclusion**

The focus areas of this chapter, Metekel zone, northwest Ethiopia, scrutinized how the Gumuz communities adapt the adverse effects of climate variability and investigated determinants of the use of identified adaptation strategies/options in the area.



The farmers perceived the declining trends of crop yield, livestock production, and the benefits that community gets from forest resources for the last 5 years. Although it is different among respondents' wealth categories, the existence of food shortage gaps in the community that extends up to 7 months has been identified. The situation is worse in the case of poor community members.

In response to climate change impacts, the Gumuz communities have been practicing different adaptation strategies. Many of the autonomous adaptation responses to the impacts of climate variability/changes include collecting of wild edible plants and other forest products, selling livestock (particularly when they are not likely to get a good price), hunting, renting/selling of farm animals, selling of available household materials and/or equipments, getting support/relay on better-off relatives, and collecting and selling of different wood and wood products (Table 6). In addition, expansion of farm land, usage of drought-resistance crop varieties, replanting/sowing, and changing of sowing calendar are among reported strategies used in response to the impact of climate variability/change. However, the autonomous/community-based adaptation mechanisms have been declining both in type and amount. This is mainly due to provision of forest lands for large-scale agricultural investments and the progressively increasing population pressure. The few households are able to improve their farming practices, for example, in using improved agricultural inputs. Lack of awareness on improved agricultural practices, poor saving, and working culture and dependency on natural resources to fulfill their food shortage gaps were known as the main constraints to adopting these practices. These further resulted in declining of community resilience to the level of crisis which requires direct intervention and support. This calls for a planned action to ensure households meet their consumption needs.

## Recommendations

- Unless communities actively engage in reflexive learning processes about the causes of systemic changes and the links between local and global processes, there is a risk that community resilience becomes nothing more than an illusion. Hence, introduction of awareness raising programs that improve working and saving culture and climate information appear to be important mechanisms as they support the adoption of several adaptation strategies that build community resilience. Special skills training program is keenly important for the local community so that they will participate and benefit from both government- and private sectors-initiated development programs which are underway in the area.
- The capacity of the community to adopt climate change by using autonomous adaptation is degrading. Therefore, greater effort is needed to increase the resilience of households to cope and adapt with climate variability, through maintaining their autonomous means systematically, and social safety net programming till the community transformed from their autonomous/community-based means to improved policy-driven adaptation mechanisms and adopt the

practice besides encouraging accumulation of assets and wealth through diversifying locally adaptive options.

- Given the effect of climate change on crop yields, animal production, and food availability, planned action by government is needed to ensure households meet their consumption needs. This may take the form of protecting the existing natural forest ecosystem where the community can get their day-to-day needs; for example, promotion of bamboo plantation using different plantation strategies since the community has a special attachment with the species to maintain their food security. Other public actions that would increase access to weather insurance for cash crops, of those currently adopted by the community (sesame production) and creating market linkage, early-warning preparedness, and increasing food stockpiles to be used during poor production years need to be considered.
- Besides the available potentials and the existing policy direction at national level, irrigation development interventions are overlooked both at individual and community level in the area. This suggests that investments in irrigation infrastructure would help farmers to engage in higher value crops, thereby increasing farm revenues besides creating alternative farm production for their subsistence life. There is also an identified need for greater investments in promoting appropriate agricultural extension services, locally adaptive and affordable technologies, and accessing local-level research institution to support the effort of the community in availing locally adaptive food crops variety to improve the future well-being of the community in the area.

---

## References

- Abbate W-S (2002) Gumuz and Highland Resettlers: differing strategies of livelihood and ethnic relations in Metekel, Northwestern Ethiopia. PhD Dissertation, University of Gottingen, Gottingen
- Alinovi L, Mane E, Romano D (2009) Measuring household resilience to food insecurity: application to Palestinian households. Working Paper. EC-FAO Food Security Programme
- Anonymous (2004) Benishangul-Gumuz Regional State Rural Development Coordination Office (2004) Three-year Strategic Plan (2003/04–2005/06)
- Anonymous (2011) Benishangul-Gumuz Regional State Food Security and Economic Growth, Canadian based Non-Governmental Organization Five Years Project implementation Plan (2011–2016)
- Berhe MG, Butera J-B (2012) Climate change and pastoralism: traditional coping mechanisms and conflict in the horn of Africa. Institute for Peace and Security Studies. Africa Programme, Addis Ababa
- Emerta AA (2013) Climate change, growth and poverty in Ethiopia. Working Paper no 3. CCAPS
- Esayas A (2003) Soils of Pawe Agricultural Research Center. National Soil Research Center Ethiopian Agricultural Research Organization Technical paper no 78. 23pp
- Food Security Strategy, Benishangul-Gumuz, Ethiopia (October 2004) Asossa (unpublished)
- Global Environmental Change 16:253–267. <https://doi.org/10.1016/j.gloenvcha.2006.04.002>
- IPCC (2007) Climate change 2007: impacts, adaptation and vulnerability. Contribution of Working Group II to the Fourth Assessment Report of the Intergovernmental Panel on Climate Change,

- Annex I (eds: Parry ML, Canziani OF, Palutikof JP, van der Linden PJ, Hanson CE). Cambridge University Press, Cambridge, UK, 976pp
- Nyong A, Adesina F, Elash OB (2007) The value of indigenous knowledge in climate change mitigation and adaptation strategies in the African Sahel. *Mitig Adap Strat Glob Change* 12:787–797
- Seo SN, Mendelsohn R (2008) Measuring impacts and adaptations to climate change: a structural Ricardian model of African livestock management. *Agricultural Economics*, p 38
- UNISDR (2009) Terminology: basic terms of disaster risk reduction and IISD et al. 2007. Community-based Risk Screening – Adaptation and Livelihoods (CRiSTAL) User’s Manual, Version 3.0
- Wallmark P (1981) The Bega (Gumuz) of Wollega: Agriculture and Subsistence; in people and cultures of Ethio-Sudan Borderlands (ed: Bender ML). African Studies Center, Michigan State University, East Lansing, p 79
- World Food Program (WFP), Food and Agriculture Organization (FAO) (2012) WFP/FAO Shock Impact Simulation Model for food security analysis and monitoring

**Open Access** This chapter is licensed under the terms of the Creative Commons Attribution 4.0 International License (<http://creativecommons.org/licenses/by/4.0/>), which permits use, sharing, adaptation, distribution and reproduction in any medium or format, as long as you give appropriate credit to the original author(s) and the source, provide a link to the Creative Commons license and indicate if changes were made.

The images or other third party material in this chapter are included in the chapter’s Creative Commons license, unless indicated otherwise in a credit line to the material. If material is not included in the chapter’s Creative Commons license and your intended use is not permitted by statutory regulation or exceeds the permitted use, you will need to obtain permission directly from the copyright holder.





# Impacts of Climate Change on the Hydro-Climatology and Performances of Bin El Ouidane Reservoir: Morocco, Africa

# 114

Abdellatif Ahbari, Laila Stour, and Ali Agoumi

## Contents

Introduction .....	2364
Overview of the Adopted Framework of Analysis .....	2365
Presentation of the Dam of Bin El Ouidane and the Impacts Assessment Framework ...	2365
Performance Criteria Used to Assess the Performances of the Reservoir .....	2367
Description of the Climate Models and Scenarios .....	2368
Description of the Models Embedded in the Framework .....	2369
Evaluation of the Water Demand and the Impact Assessment Criteria .....	2369
The Observed Impacts on Hydro-Climatology and Reservoir's Performances .....	2370
The Elaborated Evaporation Model .....	2370
CC Impacts on HC and Management Variables .....	2372
CC Impacts on the Performances of BEO-AEO Reservoir .....	2379
Conclusions and Perspectives .....	2382
References .....	2383

## Abstract

In arid and humid contexts, dams' reservoirs play a crucial role in water regulation and flood control. Under the projected climate change (CC) effects, even a pre-optimized management approach (MA) of a reservoir needs to be assessed in this projected climate. This chapter aims to assess the impacts of CC on

This chapter was previously published non-open access with exclusive rights reserved by the Publisher. It has been changed retrospectively to open access under a CC BY 4.0 license and the copyright holder is "The Author(s)". For further details, please see the license information at the end of the chapter.

A. Ahbari (✉) · L. Stour

Laboratory of Process Engineering and Environment, Faculty of Sciences and Techniques, Hassan II University of Casablanca, Mohammedia, Morocco

A. Agoumi

Laboratory of Civil Engineering, Hydraulic, Environment and Climate Change, Hassania School of Public Works, Casablanca, Morocco

© The Author(s) 2021

2363

W. Leal Filho et al. (eds.), *African Handbook of Climate Change Adaptation*,  
[https://doi.org/10.1007/978-3-030-45106-6\\_245](https://doi.org/10.1007/978-3-030-45106-6_245)

the Hydroclimatic (HC) variables of the basin upstream the reservoir of Bin El Ouidane (Morocco), and the effects on the performances of its preoptimized MA. The applied Top-Down assessment procedure included CORDEX climate projections, hydrological, siltation, evaporation, and management models. Concerning the HC variables, the results obtained concord with those reported in the literature in terms of trend, but not always in terms of intensity of change. On the other hand, the projections expected a decrease in the performances of the reservoir, except for criterion allocations' standard deviation, calibrated during the optimization. Also, interesting conclusions have been found like: the change in precipitation dominant form, the accentuation of the pluvial hydrological regime, the advanced snow melting due to the temperature increase. This chapter presents a typical case study on how to use climate projections for reservoir MA adaptation, without being highly and negatively influenced by the climate model uncertainties.

---

**Keywords**

Reservoir · Impact · CORDEX · Management · Performance criteria · Bin El Ouidane

---

**Introduction**

Dams' reservoirs play a crucial role in the attenuation of the intra and interannual water resources heterogeneity. In fact, either in arid or humid context, these hydraulic infrastructures permit the flood control and assure the satisfaction of different water demand. In Morocco, the dam construction policy had helped in mitigating the impacts of intra-annual precipitations variability, drought periods, and massive flood events. Nonetheless, according to global and national climate projections reports (IPCC 2014; MEMEE 2016), the potential impacts of climate change (CC) can alter partially or totally this role of water regulation. Moreover, the adaptation to future CC effects should be considered in both design and exploitation phases of dams' reservoirs. On one hand, the adaptation in the design phase should focus on the change of the available water supply (Nassopoulos et al. 2012), the frequency and intensity of floods (Tofiq and Guven 2014), and the sediment yield volumes (Bussi et al. 2014). On the other hand, the adaptation during the exploitation phase is more oriented toward the regular update of the MA, and of its parameters (Zhang et al. 2017). Nonetheless, the update of MAs should not be limited to historical data, but the use of future climate projections resulting from global and regional climate models (RCM) is a path that requires further investigation (Brown et al. 2012). Several methodologies were attempted to adapt water planning to CC (Borison and Hamm 2008; Morgan et al. 2009). Nevertheless, managers still have a suspicious attitude toward climate projections (Means et al. 2010). Nowadays, it is clear that with all the problems related to observational data quality and accessibility, some models' aspects inefficiencies, uncertainties, diversified range of projected impacts, greenhouse emissions scenarios diversity, and the deduction of conclusions from the usage of climate projections is risked and limited (Brient 2020; Sellami et al. 2016).

Other than the use of climate projections to assess a preupdated MA, they can also be beneficial to highlight some negative aspects of the management to correct, or other positive points to enhance.

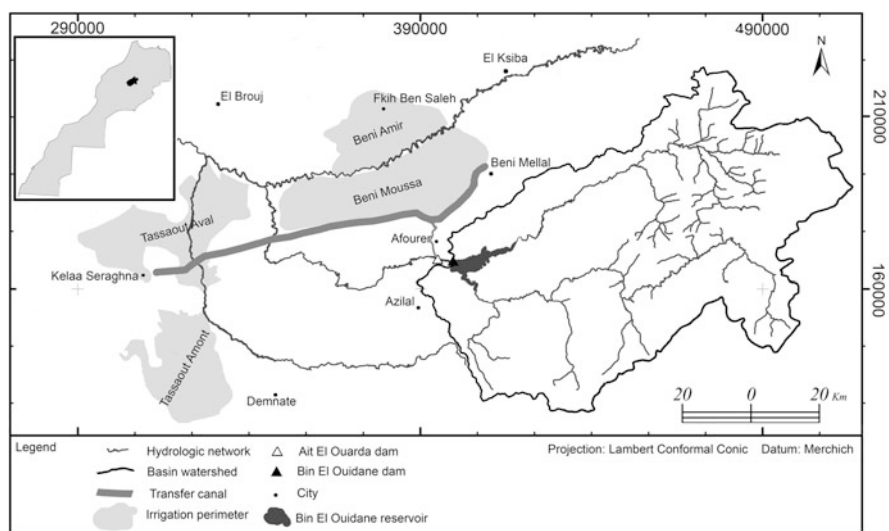
This chapter presents an assessment of the potential impacts of future CC projections on the Hydroclimatic (HC) variables on the basin upstream the dam reservoir of Bin El Ouidane, and the impacts on the future performances of the preoptimized Management Approach (MA) of this reservoir. In addition, the chapter aims to converge to conclusions that can be useful in the enhancement of the preoptimized approach. Furthermore, a comprehensive procedure that can be generalized to adapt reservoir MAs of other reservoirs worldwide is proposed.

## Overview of the Adopted Framework of Analysis

### Presentation of the Dam of Bin El Ouidane and the Impacts Assessment Framework

The hydraulic complex of Bin El Ouidane-Ait El Ouarda (named hereafter “BEO-AEO”) is located in the high Atlas of Morocco, and composed of the major 1500 Mm<sup>3</sup> reservoir of Bin El Ouidane (BEO), and its 4 Mm<sup>3</sup> compensatory reservoir Ait El Ouarda (AEO). BEO-AEO was constructed in 1953 to satisfy the water demand of: (1) irrigation perimeters of Beni-Moussa and Tassaout-Aval; (2) drinking water of Afoures, Beni-Mellal, and neighboring villages; (3) production of hydroelectricity; and (4) flood control (Fig. 1).

The BEO-AEO reservoir complex is located at the outlet of an upstream basin of 6500 km<sup>2</sup>. The analysis of the past hydro-climatologic variables evolution within the

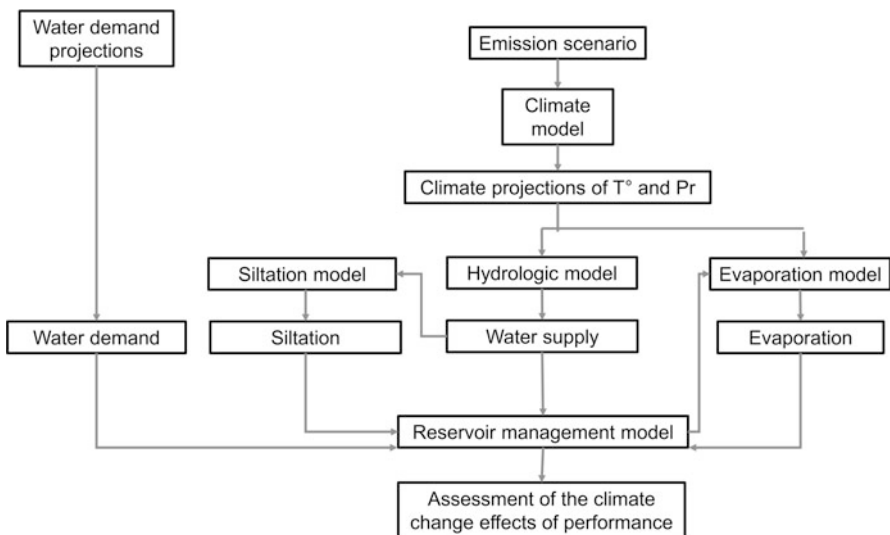


**Fig. 1** Geographical map locating the basin of BEO, the dams, and the irrigated perimeters

basin of BEO (Ahbari et al. 2017) shows an augmentation trend of the annual temperature (+0,4 °C in 1989–2013 and of evaporation from the reservoir (+470 mm in 1976–2006), as stagnation of annual rainfall (around 400 mm during 1976–2014) and a substantial drop of the annual water supply to the reservoir by almost 50% after 1976 (from 1350 Mm<sup>3</sup> during 1939–1976 to 750 Mm<sup>3</sup> during 1976–2014).

In order to assess the impacts of future CC effects on the HC variables inside the basin located upstream the complex, the management variables of BEO-AEO and the performances of BEO-AEO, the typical Top-Down procedure described in Fig. 2 is used.

As shown in Fig. 2, the starting point is to choose a climate scenario. The appropriate way to proceed is by testing at least two opposite scenarios: one optimistic and another pessimistic. This will permit to have an idea about the variation interval of the eventual impacts. Then, the selected climate scenario will drive a climate model in order to output the future projections of temperature and precipitations for a given area. In general, the regional climate model is more suitable for the assessment of CC impacts assessment in basin-scale studies (Singh et al. 2019). After that, the resulting climate projections series will be used as direct entries for a prevalidated hydrologic and evaporation models. Once the projected water supply series are calculated, they will be inputted to a prevalidated siltation model to estimate the projected annual siltation volumes. The next step is to run the reservoir management model using the projected series from the hydrologic, siltation, and evaporation models, in association with the projected water demand. Finally, by using representative performance criteria, the results of the projected reservoir behavior are analyzed and compared to the performances outputted by the pre-optimized MA described in detail in Ahbari et al. (2019).



**Fig. 2** Typical top-down procedure to assess the CC effects on reservoir performances

Since this chapter is more concerned about the daily management behavior, a daily time step is adopted. The reference period is between 1 March 1986 and 31 August 2015 (similar to the IPCC reference period for its AR5 report), and the projection period occupies the period between 1 March 2020 and 31 August 2049. The following subsections introduce the different components and models used in order to apply top-down assessment procedures to BEO-AEO.

## Performance Criteria Used to Assess the Performances of the Reservoir

### The Reliability

This criterion is calculated in relation to the duration of the demand satisfaction, as proposed by McMahon et al. (2006) in Eq. 1:

$$RI = \frac{Nb\_of\_times\_D_t = 0}{n} \quad (1)$$

where  $D_t$  is the deficit at time step  $t$ ;  $n$  is the number of time steps.

### The Resilience

It is the probability that a state of demand's satisfaction follows a state of demand's dissatisfaction (Sandoval-Solis et al. 2011). The formula used is described in Eq. 2:

$$Rs = \frac{Nb\_of\_times\_D_{t+1} = 0\_follows\_D_t > 0}{Nb\_of\_times\_D_t > 0} \quad (2)$$

### The Vulnerability

It is the likely deficit value of the system if a state of demand's dissatisfaction occurred (Hashimoto et al. 1982). In this chapter, the formula that estimates an average value of the likely deficit is adopted as shown in Eq. 3 (Sandoval-Solis et al. 2011):

$$Vul = \frac{\sum_{t=1}^n D_t / Nb\_of\_times\_D_t > 0}{water\_demand} \quad (3)$$

### The Sustainability

It is a criterion that attempts to unify in a unique value the information driven by more than one performance criterion. The reformulated Looks (1997) sustainability formula suggested by Sandoval-Solis et al. (2011) is the one used in the chapter (Eq. 4):

$$Sus = \sqrt[3]{RI \times Rs \times (1 - Vul)} \quad (4)$$



### The Allocations' SD

This criterion permits to unveil to what extent a specific management approach has an unpredicted and unstable water allocations (Ahbari et al. 2019). Equation 5 details the calculation expression:

$$SD = \frac{\sqrt{\sum_{t=1}^{n-1} (X_t - X_m)^2 / (n-1)}}{\text{Water\_demand}} \quad (5)$$

where  $X_t$  is the allocated volume at time step  $t$ ;  $X_m$  is the average allocated volume;  $n$  is the number of time steps.

### Description of the Climate Models and Scenarios

As it was mentioned before, two representative concentration pathways (RCP) were used (Van Vuuren et al. 2011): the optimistic scenario “RCP 2.6” and the pessimistic scenario “RCP 8.5.” The selection of the RCP 8.5 and 2.6 as assessment scenarios is driven by the fact that the objective of the chapter is to track the potential interval of plausible changes resulting from all levels of mitigation policies (no policy, weak, modest, below 2 °C policies). Therefore, the RCP 8.5 is chosen to represent the pessimistic trend, even though it is a highly unlikely case (Hausfather and Peters 2020), and the RCP 2.6 to simulate the optimistic tendency willing to keep the global warming below 2 °C. Concerning the climate projections, the data from the COordinated Regional Climate Downscaling EXperiment (CORDEX; Giorgi et al. 2009) were employed. The data output used are the bias-corrected climate projections over the EUR-11 domain which contains our studied area. The bias-corrected CORDEX data are accessible via the link <https://esgf-data.dkrz.de/search/cordex-dkrz/>. By respecting the same specifications during the data filtration (same Regional Circulation Model (RCM) and driven Global Circulation Model (GCM)) for both RCP scenarios, only two RCM were available for use: RCA4 and REMO2009. These RCM are driven respectively in their boundaries conditions by the GCM: ICHEC-EARTH and MPI-M-MPI-ESM-LR. The NetCDF files containing the bias-corrected projections were downloaded for each variable-RCP-RCM triple, for the projection period 2020–2049. Since a global hydrologic model was used to simulate the streamflow in the basin, the calculation of the average projected series for the basin for each Variable-RCP-RCM triple was mandatory. So, the 6500 km<sup>2</sup> basin upstream BEO-AEO is divided into a 11 km grid cells, and the projected series of each triple variable-RCP-RCM at the center of each cell are extracted. The transformation of the cell center coordinates from regular to rotated was done using the software AgriMetSoft (2017). Then, the average basin series for each triple are calculated by averaging the projected series for all cells. To get the projected series for each variable-RCP couple, an ensemble mean was calculated using the series of the two RCM, and then converted to IS units (°C and mm).

## Description of the Models Embedded in the Framework

The hydrologic model used is the hydrologic modeling system (HMS) model, with a simple canopy and surface formalisms, the soil moisture accounting (SMA) as the loss method, the Clark Unit Hydrograph (Clark UH) as the transform method, and the exponential recession method to simulate the baseflow component. The model was calibrated and validated over the basin in previous works (Ahbari et al. 2018a, b). The HMS model of the basin was obtained after a training-validation and a detailed sensitivity analysis processes that permit to converge to the best HMS model in terms of efficiency. Nonetheless, it is necessary to highlight that this rainfall-runoff model exhibits some deficiency in the simulation of some flow peaks as described in Ahbari et al. (2018b). This deficiency was taken into consideration while interpreting and discussing the results of this chapter. About the siltation process in BEO reservoir, it is modeled using a preestablished model (Ahbari et al. 2018c) integrating sediment yield to the reservoir and the sediment consolidation phenomena. As described in detail in Ahbari et al. (2018c), the preestablished siltation model was able to simulate the observed time series of siltation in BEO using a genetic algorithm optimization process. For the evaporation from the reservoir water plane, it is estimated using a multiple linear regression model between the monthly evaporated volume as a dependent variable and the monthly average temperature, the monthly potential evapotranspiration (ETP) and the reservoir water level at the beginning of the month, as explanatory variables. The mentioned evaporation model was calibrated and validated for the purpose of this assessment study, and the results are shown in the results section.

Concerning the BEO-AEO management model, it is represented by an optimized version of the current MA practiced in BEO-AEO. The optimization of the current MA was done using the genetic algorithm, and its performances were evaluated in a two-step process: a training-validation and a sensitivity analysis processes. For brevity purposes, more details about the reservoir operations fulfilled by this model please refer to Ahbari et al. (2019).

## Evaluation of the Water Demand and the Impact Assessment Criteria

Due to the lack of detailed data about the projection of the daily water demand for each user for the projected period of 2020–2049, the series of the projected daily water demand was constructed by extrapolating the current hypothetical water demand, using the available projected evolution ratio of the basin of Oum-Er-Rabia. In fact, the basin of BEO-AEO is part of the basin of Oum-Er-Rabia for which the projected evolution ratios in 2020, 2025, and 2030 are available. Beyond 2030, the same ratio as for 2030 is applied till the end of the projected period. The current hypothetical water demand refers to an annual water demand series represented by the year on which the releases from BEO-AEO are maximal. This hypothetical series should be the best to represent the current water demand series (which is inaccessible for the authors) since the daily deficits will be at their minimal

values ever recorded. Nevertheless, it is important to notice that the constructed annual water demand at the 2030 horizon (constructed using the concept described above) is almost equal to the only information publically available about the annual water demand for BEO-AEO for the same horizon (annual water demand at the 2030 horizon).

To evaluate the impacts of CC on the HC variables inside the basin of BEO-AEO and on its management variables, two assessment criteria were used: the average values between the reference and the projected periods, and the intra-annual evolution of the HC variables. Additionally, the following criteria were used to assess the change in the performances of the BEO-AEO complex in satisfying the water demand: the deficit, the reliability, the resilience, the vulnerability, the sustainability, and the standard deviation of allocations.

## The Observed Impacts on Hydro-Climatology and Reservoir's Performances

### The Elaborated Evaporation Model

The calibration period starts from March 1986 to February 2002, and the validation begins in March 2002 and finishes in December 2008. Figure 3 shows the linear regressions during the calibration and the validation periods.

As seen in Fig. 3, the linear regression is clear, important ( $R^2 = 0.72$  for calibration and 0.76 for validation), and statistically significant at 5% level (p-value  $< 0.0001$ ). The resulting multiple linear regression relates the monthly evaporated volume from the reservoir of BEO to three explanatory variables as described in Eq. 6:

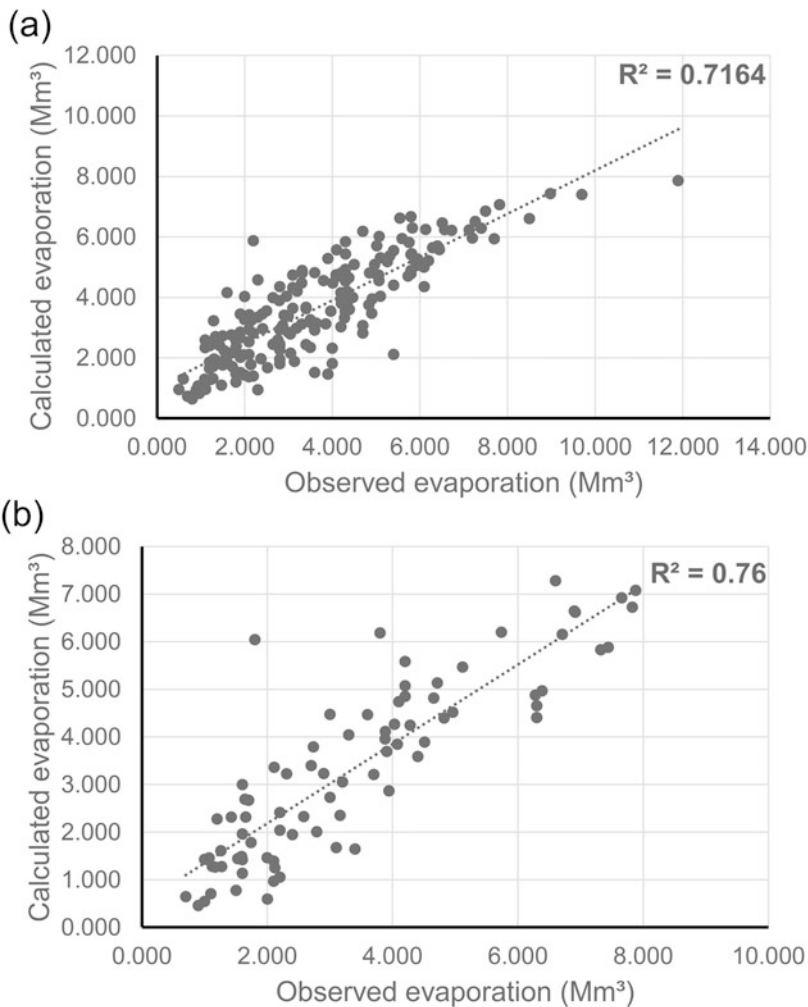
$$V_{EVP} = -46.03 + 0.06 * H_{WL} + 0.26 * T + 0.25 * ETP \quad (6)$$

where  $V_{EVP}$  is the monthly evaporated volume ( $Mm^3$ );  $H_{WL}$  is the water level in the reservoir of BEO at the beginning of the month (m);  $T$  is the average monthly temperature ( $^{\circ}C$ );  $ETP$  is the monthly potential evapotranspiration (mm).  $H_{WL}$  and  $T$  are both based on observed values of water level in the reservoir of BEO and the average temperature at the gauge of Tilouguite. The  $ETP$  was calculated based on the formulae (Eq. 7) dedicated for rainfall–runoff modeling purposes proposed by Oudin et al. (2005).

$$ETP = \frac{R_e T_a + 5}{\lambda \cdot \rho \cdot 100} \Rightarrow \text{if } T_a + 5 > 0 \quad (7)$$

$$ETP = 0 \Rightarrow \text{otherwise}$$

where  $ETP$  is the rate of potential evapotranspiration ( $mm \text{ day}^{-1}$ ),  $R_e$  is extraterrestrial radiation which depends on latitude and Julian day ( $MJ \text{ m}^{-2} \text{ day}^{-1}$ ),  $\lambda$  is the



**Fig. 3** Linear regression between observed and calculated evaporation during (a) calibration and (b) validation periods

latent heat flux equals  $2,45 \text{ (MJ kg}^{-1}\text{)}$ ,  $\rho$  is the density of water ( $\text{kg m}^{-3}$ ), and  $T_a$  is mean daily air temperature ( $^{\circ}\text{C}$ ).

By integrating the water level as an explanatory variable, the obtained equation implicitly integrates the most important parameter that controls the evaporation from the reservoir: the surface of the water plane. The regression would be more substantial if other variables data were available like humidity and wind speed (Condie and Webster 1997).

## CC Impacts on HC and Management Variables

### Change in Average Values

Table 1 resumes the change in the average values of different HC and management variables between the reference and the projection periods.

The six key observations extracted from Table 1 are:

Firstly, negative impacts (qualified as negative because they alter directly or indirectly the performances of the reservoir) are suggested by both RCP for all variables, except for evaporation which will decrease. In fact, this first observation is an expected result and a concordance with the observed negative impacts of CC at both global (IPCC 2014) and national (MEMEE 2016) scales, especially for temperature and precipitation. Those negative impacts include: the increase of the average air temperature by at least +3.70 °C, the increase of ETP by at least 18.46%, the decrease of precipitation by 54.16% (RCP 2.6), the decrease of water supply by not less than 59%, the diminution of the stocked volume by 65.19% (RCP 8.5), and most importantly, the decline of water allocations to users to reach 60.07% (RCP 8.5). That said, what does not concord with global and national tendencies is the evaporation evolution trend. In fact, the downward trend of evaporation is explained by the decreasing trend projected for the variable water stocked in the reservoir, caused by the decrease of precipitations and water supply to the reservoir. The evaporation here is not to confound with the evaporation part of the evapotranspiration, which as it is seen will increase.

Secondly, except the temperature and the ETP which are related, the two RCPs drain practically the same impact on HC variables. Regarding this second observation,

**Table 1** Change in the average values of the HC and the management variables between the reference and the projection periods for both RCP 2.6 and 8.5

		Reference period	Values		Difference (%) to the reference period	
		1986–2015	RCP 2.6	RCP 8.5	RCP 2.6	RCP 8.5
HC variables	Temperature (°C/day)	16.61	20.32	20.71	+3.70 °C	+4.10 °C
	ETP (mm/day)	2.96	3.51	3.56	+18.46	+20.08
	Evaporation (Mm <sup>3</sup> /day)	0.118	0.082	0.080	−30.52	−31.81
	Precipitations (mm/day)	1.16	0.53	0.53	−54.46	−54.16
	Water supply (Mm <sup>3</sup> /day)	2.25	0.90	0.88	−59.89	−60.82
Management variables	Stocked volume (Mm <sup>3</sup> /day)	599.89	221.02	208.84	−63.16	−65.19
	Allocated volume (Mm <sup>3</sup> /day)	1.88	0.797	0.75	−57.92	−60.07

the similar impacts of both RCP in terms of intensity and trend can be related to three reasons: (1) the horizon of projection 2020–2049 is probably far enough to sense a difference between an optimistic and pessimistic scenario in terms of warming, but it is not far enough to let the RCP 2.6 decreasing emissions to take effect on other aspects of climate much more complex like precipitations (Giorgi et al. 2019); (2) The used RCM and their driven GCM models are likely capable of simulating air temperature directly correlated to greenhouse gases concentration, but still have problem with the simulation of climate variables indirectly related to these gases like precipitations (Schliep et al. 2010); (3) since the projected period is located in the first half of the twenty-first century, it is expected that the difference between scenarios remains small (IPCC 2014; Hawkins and Sutton 2009). This last reason can be more highlighted by looking at the variables evaporation and water supply (obtained using the validated evaporation and hydrologic models), for which the difference between the RCPs is more important, even though they both integrate in their calculation the climate models outputs. For the ETP, more difference between the two RCPs is obtained since it was calculated by the formula of Oudin et al. (2005), which relates the ETP to the temperature directly without requiring any other climate variable. Moreover, the difference between the ETP values for the two RCPs is statistically insignificant at 5% level ( $p$ -value = 0.058), which supports the two reasons mentioned.

Thirdly, the difference between the optimistic and the pessimistic RCP is more pronounced for the management variables than the HC variables: Concerning the third observation, it highlights a valuable conclusion: if following the RCP 2.6 emissions limits will not have immediate and important repercussions on the climate system (IPCC 2014; Marzeion et al. 2018), it would be more likely beneficial to other systems like the capacity of dam's reservoir to regulate water volumes interannually. This conclusion can be supported by the more interesting difference between RCP 2.6 and RCP 8.5 impacts on stocked and allocated volumes. In addition, the cause behind this difference between RCPs impacts for management variables is that the optimized MA has acquired some adaptation capabilities during the sensitivity analysis done in Ahbari et al. (2019). In fact, the optimized approach was defined after testing different scenarios of pluviometry (low, moderate, and high) and water demand (normal and high scenarios).

Fourthly, unlike other variables, the RCP 8.5 would induce less impacts than the RCP 2.6 for the precipitation variable. With regard to this fourth observation, statistical significance tests were applied to the difference between the RCP 2.6 and 8.5 precipitation values, and found it statistically insignificant at 5% level ( $p$ -value = 0.878). The 95% confidence interval on the difference between the two RCPs values of precipitation is ]-0.047; 0.040[. Therefore, one cannot be sure about the cause responsible of this apparent anomaly: Is it the RCM and the GCM used or it is just a question of sampling.

Fifthly, even though directly related, the precipitations and the water supply variables are not similarly influenced by the RCP selected. In other words, the fifth observation stipulates that while the precipitation is more impacted by the RCP 2.6, the water supply variable is more influenced by the RCP 8.5. This may sound

intriguing, because since the two variables are highly related then they are supposed to behave similarly when they are trained by a given RCP scenario. However, this apparent anomaly could be explained by these two reasons: (1) as it was mentioned before, the difference between the RCP 2.6 and 8.5 for the variable precipitation is not statistically significant; (2) also, the difference between the two RCPs for the variable water supply is statistically insignificant. Thus, the causes behind this situation can be, in addition to a problem in RCM or GCM functionalities, a problem in statistical sampling related to the projection period chosen.

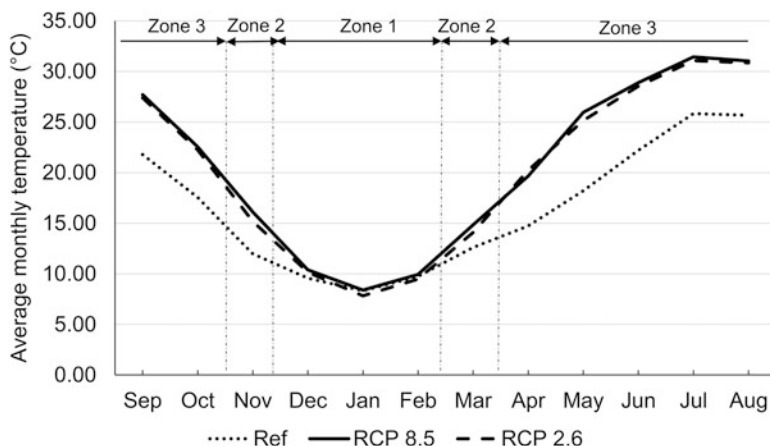
Sixthly, the percentage of change between the reference and the projection periods for all variables is very high. About this last observation, it is necessary to note that all variables values for the RCP 2.6 and 8.5 are statistically significant compared to the reference period at 5% level ( $p$ -value  $< 0.0001$ ). This means that according to the used RCMs, a statistically significant CC during the period 2020–2049 is expected in the basin upstream BEO-AEO compared to the reference period 1986–2015. Moreover, a statistically significant negative impact on the management variables will take place during the same period. For the high intensity of difference between reference and projection periods, it should be known that the values obtained include the uncertainties related to the climate, hydrological, siltation, and evaporation models. So, unlike the direction of change trend, the values of change obtained require a delicate interpretation before making any conclusion.

### **Intra-annual Evolution of the Variables**

As demonstrated in the subsection before, the projections expect a substantial change in the average value of all studied HC variables. However, it is necessary and beneficial to analyze the intra-annual evolution of this change, to detect the most impacted months, and to deduct constructive conclusions for some eventual adaptation strategies. Figure 4 represents the intra-annual evolution of the average air temperature in the basin of BEO-AEO.

It is clear from Fig. 4 that the increase of temperature would not concern all months, and the difference between the two RCPs monthly temperature is practically zero. In fact, the hydrological year can be divided into three zones, differentiated by the intensity of temperature increase. Thus, three zones are recognizable: (1) zone 1 (December–January–February) characterized by a very limited increase; (2) zone 2 (November and March) which surrounds zone 1, and it shows a moderate increase of temperature; (3) zone 3 (April to October) known for its high-temperature increase compared to the other zones.

This zonation in the temperature augmentation was also observed in other basins using different RCM and GCM (Bannister et al. 2017; Santer et al. 2018). According to these case studies, the zones' length can change from one month to several months, but the common conclusion is that the winter season had never shown any increase of temperature. The reasons proposed to explain this unique behavior are: (1) climate models are deficient in simulating the Arctic oscillation and the north hemisphere winter climate (Cohen et al. 2012); (2) the high monthly bias was found



**Fig. 4** Intra-annual evolution of the average air temperature under RCP 2.6 and 8.5 in the basin of BEO-AEO

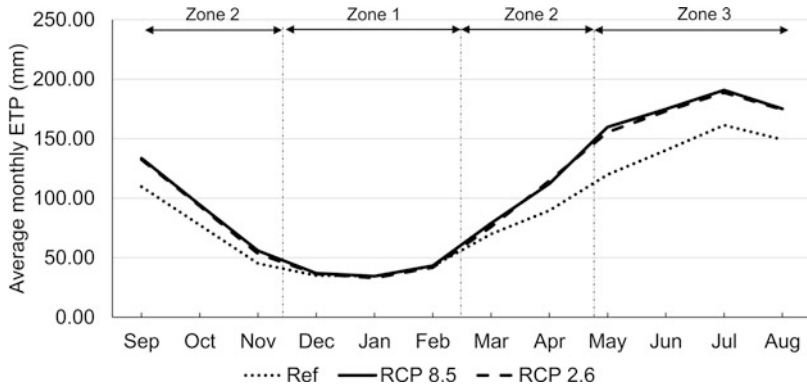
correlated to climate models characterized by sparse horizontal resolution, and thus, to topographical factor (Bannister et al. 2017); (3) the surface-cloud feedback process might be incorrectly represented in climate models (Jiang et al. 2015); (4) the natural cause is not excluded either, because Osuch and Wawrzyniak (2016) have found a comparable seasonality in temperature evolution via the analysis of historical data.

Concerning the difference between the RCPs impacts on monthly air temperature, it was found that the difference between the RCP 8.5 and 2.6 temperature augmentation is statistically significant for November and May only (at 5% level, p-value equals 0.002 and 0.005, respectively). On the other hand, the monthly temperature increase compared to the reference period is statistically significant for all months, apart from January and February (p-value equals 0.818 and 0.626, respectively). These 2 months belonging to zone 1, confirm the characteristics of zone 1 showing, in terms of increasing values, a very limited change.

Like the air temperature, the ETP intra-annual variability presents the same zonation configuration (Fig. 5). Nonetheless, in the case of ETP, the zones' disposition has changed. Hence, the very limited increase zone (zone 1) covers December, January, and February (the change is statistically insignificant for January and February with a p-value reaching 0.926 and 0.672, consecutively at 5% level). Then, comes the moderate increase zone (zone 2), which gained some months previously occupied by zone 3 in Fig. 4 (March, April, September, October, and November). Finally, there is zone 3 starting on May and finishing on August, which shows a high increase of ETP compared to other months. All the differences between the reference period and the RCPs are statistically significant for all months covered by zones 2 and 3.

In reality, the ETP in this study was calculated using a formula that requires only the temperature and the latitude. By consequence, it was expected that the ETP intra-





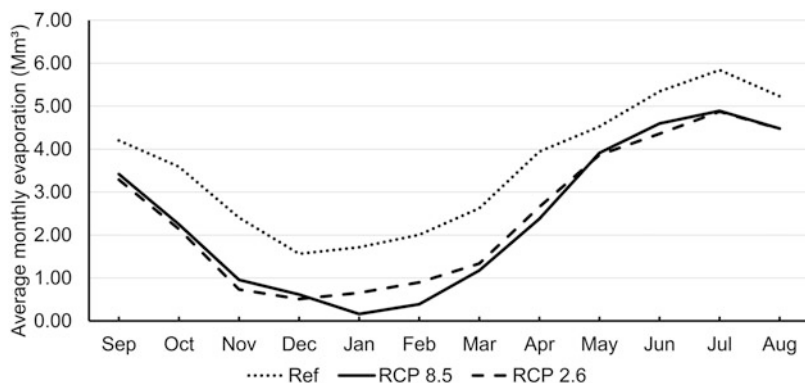
**Fig. 5** Intra-annual evolution of ETP under RCP 2.6 and 8.5 forcing in the basin of BEO-AEO

annual variability would be similar to the temperature one. Hence, one can wonder why the pattern of intra-annual variability of temperature and ETP is different? In fact, this is related to the other parameter of the ETP calculation equation: Latitude. Thus, the translation of zones in Fig. 5 compared to Fig. 4 is related to the influence of the latitude parameter, and to its implicit factors such as the global radiation received by the studied area.

Other than the impact zonation, Fig. 5 indicates also that the differentiation between RCP 8.5 and 2.6 impacts on monthly ETP is visually hard to spot. In fact, statistical tests confirm this observation for all months, November, December, and May excepted ( $p$ -values equals 0.002,  $<0.0001$  and 0.005 respectively). Hence, if an issue of climate modeling reason is expunged, and the natural cause confirmed, this may indicate an interesting classification of months in terms of their ETP responses to greenhouse gases emissions. Consequently, once confirmed, this conclusion might be useful to take into consideration in the adaptation of reservoir operations approaches, so that they became prepared to future CC effects. The zonation remark is also to consider in those adaptation methodologies, since it is repeated in both temperature and ETP results.

For the variables temperature and ETP, the months covered by each zone can be seen differently by each reader, but it is sure that a zonation representing different intra-annual variability is present, and should be investigated further, and eventually taken into consideration in future adaptation strategies.

Regarding the intra-annual variability of evaporation from the reservoir of BEO, Fig. 6 describes a different monthly response of this variable compared to temperature and ETP. In fact, instead of showing months where the change is zero or very limited and others more impacted by CC, the evaporation intra-annual variability concerns all months with a slight difference in intensity from one month to another. That said, it is easy to spot months (December to March) where the difference between projections and reference curves is more pronounced than others (May to September). This is explained by the evolution of water stocked in the reservoir throughout time, it self-controlled by water supply and precipitations seasonality.



**Fig. 6** Intra-annual evolution of evaporation under RCP 2.6 and 8.5 forcing in the reservoir of BEO

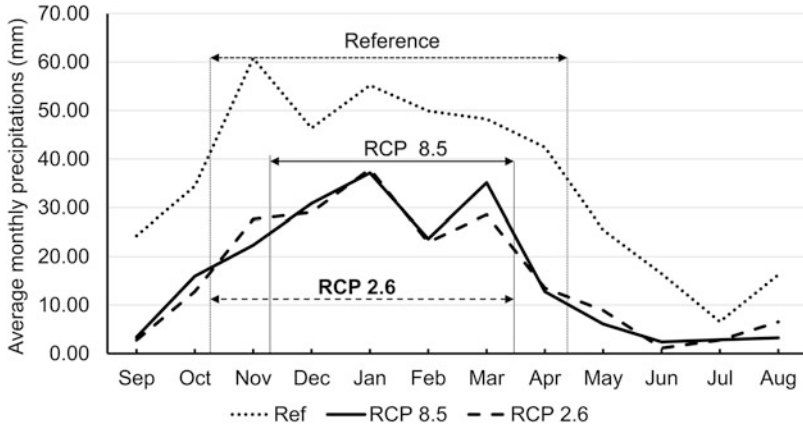
As seen, the downward trend of the average evaporation changes detailed in the subsection ‘3.2.1 Average values change’ is detected in all months without exception, in opposition to the variables temperature and ETP. The monthly evaporation diminution shown in Fig. 6 are all statistically significant for all months at 5% level, with p-values ranging from 0.006 for September to  $<0.0001$  for months between October and April. On the other hand, the difference between the two RCPs impacts on monthly evaporation seems to follow a differentiation by months. Hence, there is November, January, and February where the difference between RCP 2.6 and 8.5 is visible and statistically significant (p-value equals 0.044 for the first and  $<0.0001$  for the last), and the other months where the type of scenario do not apply any statistically relevant difference.

With regard to the variable precipitations, Fig. 7 resumes the evolution of it under reference, RCP 2.6 and RCP 8.5 scenarios. By reading Fig. 7, four fundamental remarks can be deduced: (1) the diminution tendency affects all months, under the two RCPs; (2) the period covered by the rainy season is getting short, especially for the RCP 8.5; (3) The months with very low pluviometry are more frequent (For instance, from June to September); (4) the RCP 8.5 expects a delayed rainy season, while the RCP 2.6 suggests that it would be advanced temporally.

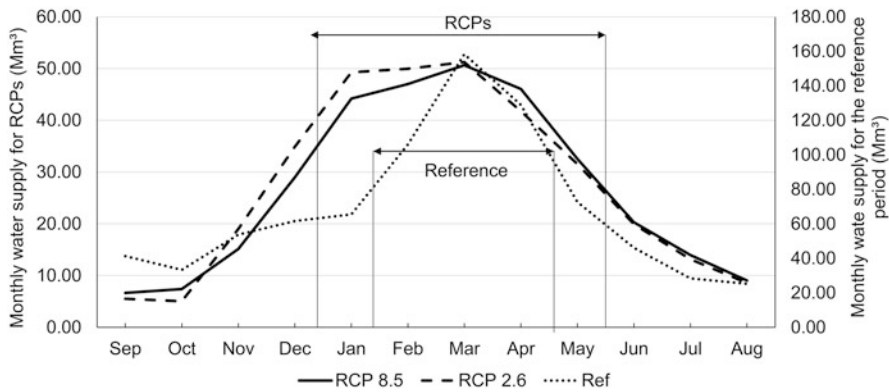
These remarks mean that the basin of BEO-AEO will experience a change in terms of the dominant precipitations type depending on the RCP considered (more solid for the 2.6 RCP, and more liquid for the 8.5 RCP), a change in the intensity and/or frequency of summer storms (since the precipitations will be reduced considerably during this season) and of course all the repercussions that will be sensed in the hydrologic regime.

Statistically speaking, although the visual difference between the RCP 2.6 and 8.5 curves for some months (November and March for example) is clear, no significant difference was found for any month.

About the water supply to BEO-AEO and its variation through time, Fig. 8 compares the intra-annual evolution during the reference period and under the



**Fig. 7** Intra-annual evolution of precipitations under RCP 2.6 and 8.5 forcing in the basin of BEO-AEO



**Fig. 8** Intra-annual evolution of water supply under RCP 2.6 and 8.5 in the basin of BEO-AEO

RCPs scenarios. The evolution of water supply concurs with the conclusions of Fig. 7 and Table 1, assuming that future water supply will decrease in terms of volume and temporal distribution. In addition, Fig. 8 demonstrates that in parallel with the reduction of its volume drained, the season of “high supply” will prolong temporally compared to the reference period of 1986–2015. Moreover, the change of hydrologic regime from pluvio-nival to pluvial, mentioned in Ahbari et al. (2017), will be accentuated in both RCPs. Thus, the hydrologic peak is located in March, after being culminating in April during the period 1939–1976 (Ahbari et al. 2017). The accentuation of the pluvial regime can be justified when observing the RCPs curves, which present a peak roughly in the form of a plateau, especially for the RCP 2.6, where the plateau covers the months January–February–March.

In addition, the difference during March between the water supply curves of the reference and the projection periods' is statistically significant ( $p$ -value  $< 0.0001$  at 5% level), while it was insignificant during the same month for the variable precipitations. This may indicate that the impact of climate projections on March water supply was not induced via a change in March precipitations, but it is caused by another factor. In fact, the presumed vector of change is an advanced melting of the solid precipitations that occurred in previous months (especially for the RCP 2.6 where the dominant form of precipitations is the solid one), accelerated by the projected temperature increase. Then, if this is the case, the conclusions mentioned by other studies and confirmed in this chapter, about the incapacity of the RCM and GCM models to simulate the winter temperature increase, are reinforced again.

Additionally, in contradiction to the observation about dominant precipitation seen in Fig. 7, the water supply evolutions for the RCP 2.6 and 8.5 do not match the type of regimes expected.

Even though the solid precipitations are expected in RCP 2.6, the hydrologic regime is almost the same as for 8.5 on which liquid precipitations are more dominant. This is explained by the fact that the solid precipitations will not wait too long to melt, since the increase in temperature already mentioned provoke an advanced melting, and will not wait until the spring season. If this explanation is correct, this means that the reasons stated before about the stability of temperature in the winter season are correct, and the models are really encountering issue with the simulation of climate during this season.

## CC Impacts on the Performances of BEO-AEO Reservoir

After running the assessment procedure detailed in Fig. 2 for the RCPs 2.6 and 8.5, the performances of the optimized MA of BEO-AEO under CC projections were assessed, via the calculation of the six most important criteria. Table 2 details the results obtained at a daily time-step scale.

According to Table 2, except the standard deviation of allocations, all aspects of performance will be deteriorated under the two emissions scenarios. Therefore, the

**Table 2** Average daily values of the performance criteria of BEO-AEO calculated for the reference and projection periods

	Values (%)			Difference to the reference (%)	
	Reference	RCP2.6	RCP8.5	RCP 2.6	RCP 8.5
Deficit	26.68	67.01	68.70	+151.16	+157.48
Reliability	25.50	8.58	7.96	-66.33	-68.77
Resilience	11.16	4.58	4.18	-58.98	-62.50
Vulnerability	47.76	75.87	77	+58.88	+61.24
Sustainability	24.59	9.82	9.15	-60.04	-62.789
Standard deviation of allocations	38.73	19.36	17.77	-50.01	-54.10

percentage of deterioration can reach +157.48% (RCP 8.5) for the daily deficit, -68.77% (RCP 8.5) for the daily reliability, not less than -58.98% (RCP 2.6) in the case of the resilience and sustainability and at least +58.88% (RCP 2.6) of vulnerability deterioration. Moreover, it is proved by Table 2 that the vulnerability is the less impacted aspect, and the deficit the most damaged one.

Oppositely, the standard deviation of water allocations will be improved and its daily value will fluctuate between 17.77% (RCP 8.5) and 19.36% (RCP 2.6). The reason explaining this improvement is that the establishment of the optimized MA included a phase where the optimization of the releases to users has been performed. So, performing this update permitted to the MA to acquire an attitude to keep the variability of allocations minimal, under stressing climate circumstances.

Furthermore, and unlike the HC variables, the type of the scenario chosen appears to have an effect more considerable on the performances displayed by the BEO-AEO system. This confirms the conclusion mentioned before that: if the RCP 2.6 emissions guidelines are followed, it is certain that the climate will need decades to restore its regular conditions, but the systems impacted by this climate (the reservoir operations in this case) will rapidly start to show substantial enhancement.

By consequence, in the case of BEO-AEO complex, the aspects of performance that will manifest intensively this attitude are the daily deficit and the resilience. In fact, the reason behind the fast response of the deficit criterion is similar to the reason behind the improvement of allocations variability. Regarding the resilience, it is related to the fact that the choice of this optimized approach as the best one (Ahbari et al. 2019), was preceded by a sensitivity analysis towards different conditions (including varying pluviometry and water demand scenarios). Therefore, the different scenarios tested had likely helped in adapting the approach to extreme conditions, and by consequence, they improved its resilience capacities. Furthermore, the rapid response of the resilience criterion to the change of RCP can also be explained by the fact that, as shown in Ahbari et al. (2019), the resilience of BEO-AEO was the aspect of performance on which the manager of this reservoir complex have focused while calibrating the MA for the last time. This may indicate that if a regular update of the current MA was done, by including the resilience criterion in the objective function, the resilience may show similar results as those shown by the standard-deviation of allocations.

Overall, the results of the CC effects assessment present a clear tendency to have negative impacts on both the hydro-climatology of the basin of BEO-AEO and on the performances of the complex. In fact, the impacts projected concord with those reported in the literature (McSweeney et al. 2010; Ouraich 2014; MEMEE 2016; Filahi et al. 2017) in terms of trend, but not always concerning the intensity of change. For instance, McSweeney et al. (2010) and Ouraich (2014) stated a range of temperature variation across Morocco oscillating between +1.5 and +3.5 °C for 2060, and a maximum decrease of precipitations reaching 52%. Nevertheless, MEMEE (2016) mentioned that by 2065, air temperature in Morocco would increase from +0.5 °C to +2 °C, and precipitations change is projected to vary between +10% and -20%, depending on the region and the RCP scenario.

Nonetheless, it is necessary to mention that while the projected temperature and precipitations are averaged over all the catchment areas, the temperature, precipitation, and ETP of the reference period are gauge-based series. Thus, this may be explaining some of the differences. Additionally, water supplies are also based on average precipitation over the whole basin during the projection period, while in the reference it is based on the average of six gauges. Moreover, since all the performance values are based on water supply, then even these performance evolution compared to the reference period is to take with precautions.

The differences observed could be caused by the bias-corrected climate projections used in this study. In this chapter, the use of the CORDEX bias-corrected and downscaled data was dictated by the fact that neither the availability of meteorological stations inside and around the basin (especially for temperature), or the accessibility to those data was possible at the time of completion of this study. Therefore, the use of the available ones in the training and testing of a statistical downscaling and/or bias-correction method will never converge to acceptable results. These problems of network representativeness and limitation on climate model validation were reported by several authors (Filahi et al. 2017). So, the intensity of change in these conditions will never be accurate, even without counting the uncertainties driven by the different models and data.

Nevertheless, the differences can also be related to the various uncommon aspects between the materials and methods used in this chapter, and those employed in other studies, including: (1) the choice of RCM, GCM, and all the specifications that go in parallel (domain type, spatial resolution, ensemble calculation...) (Fantini et al. 2018; von Trentini et al. 2019); (2) the climate and hydrological models characteristics (Lespinas et al. 2014); (3) the downscaling and bias correction methods used and all the uncertainties they drive during training and testing (Teutschbein and Seibert 2012; Rätty et al. 2018); (4) the choice of the reference, the projection periods, and the time step of projection (daily, monthly, or annually) used; (5) the area studied by each chapter (whole country, neighboring basin, neighboring city...).

In addition, to attenuate this disagreement between impacts assessment studies, it is recommended to proceed to the accomplishment of the following guidelines: (1) simple RCM assessment via a validation of the RCM simulations over a historical period; (2) advanced RCM assessment via a sensitivity analysis of RCM tuning parameters (Bucchignani et al. 2016); (3) The use of ensemble RCMs simulations instead of single RCM outputs, due to the benefits proven by this option (Phillips and Gleckler 2006; Filahi et al. 2017); (4) the assessment and selection of the best ensemble RCMs prediction method (Duan and Phillips 2010) without being influenced by the eventual negative impacts of ensemble mean RCM use.

However, this disagreement between studies, about the magnitude of change, is not only specific to the basin of BEO, but it is well-known worldwide at catchment scale (Sellami et al. 2016). Furthermore, the projections of CC can also differ in sign not only in magnitude (Koutsouris et al. 2010; Nassopoulos et al. 2012).

In addition, the intensity of change is not the ultimate objective in CC assessment studies, nor it is the aim of this chapter. But, the important is to prove to managers that

impacts are coming, and adaptation actions are highly recommended. Moreover, the manager should know that even with an optimized MA, without regular updates, the future performances will be heavily affected. In fact, with all the uncertainties trained by the climate, hydrological, and other models used, the use of these projections, directly, to adapt the current MAs would be useless, or even counterproductive.

In reality, the climate projections can be used indirectly by exploiting common conclusions like those mentioned in this chapter (the trend of change, the zonation in the impact of CC on the variability of temperature and ETP, the change in precipitation dominant form, the change in hydrologic regime, which months are more affected, which performance aspects are more responsive to adaptability, which ones are more impacted by CC. . .).

Hence, the current MA can be modified by adding additional parameters, and/or optimized by testing various operations conditions to take into consideration those expected change. Once those modifications are applied to the current MA, the manager can update his approach regularly to implement each time the trend of change and its intensity. Furthermore, the manager can look for the best update pattern of this new approach, by comparing different update configuration (each year, each n years. . .).

For instance, in our example, before evaluating the impacts of CC on the performances of BEO-AEO, Ahbari et al. (2019) proceeded to the update and optimization of the releases formulae. Thus, when analyzing the results of performance projections, the standard deviation of water allocations was the only criterion which had experienced an improvement of its daily value.

---

## Conclusions and Perspectives

The aim of the chapter was to assess the impacts of future CC projections on the HC variables, management variables, and the performances of the complex of BEO-AEO. To accomplish this objective, a typical top-down CC assessment procedure was followed including the use of optimistic and pessimistic emissions scenarios, RCM ensemble-mean, and prevalidated models (hydrological, siltation, evaporation, and reservoir management models). The climate projections data used were from the bias-corrected CORDEX data specific to EUR-11 spatial domain. Once the typical assessment procedure was run, the results were analyzed via: average values change, intra-annual variability, and performance criteria.

The results obtained show negative impacts for both HC (evaporation excepted) and management variables and all the performance aspects (the standard deviation of allocations excepted) of BEO-AEO. In general, the trends of HC variables change concord with other studies focusing on Morocco. Particularly, the projections expect an increase of air temperature and ETP, a downward tendency of precipitations, water supply, evaporation, stocked volume in the reservoir of BEO, allocated volumes to users. In terms of performances, and except the standard-deviation of allocations, negative trends of evolution are projected for all performance criteria: increase of deficit and vulnerability and decrease of reliability, sustainability, and

resilience. Oppositely, the variability of water allocations will be improved under the two RCPs. This improvement is related to the phase of optimization of the releases that preceded this work. Concerning the intra-annual variability of the HC variables, the following conclusions are the most important ones: the zonation in terms of the impacts of CC on the variability of temperature and ETP, the change in precipitation dominant form depending on the RCP chosen, the accentuation of the pluvial hydrological regime, the probable advanced snow melting due to the increase of temperature, the limited difference between the impacts of the two RCPs on the majority of variables and months.

Finally, it is sure that the intensity of the projected CC mentioned in this chapter, and the one reported in other papers are not similar, but all of them have a consensus regarding the tendency of this change: Negative impacts are expected. Therefore, actions should be taken in order to adapt these infrastructures to CC effects.

---

## References

- AgriMetSoft (2017) Rotation of coordinates based on CORDEX domains [Computer software]. <http://www.agrimetsoft.com/CordexCoordinateRotation.aspx>. Accessed 10 May 2020
- Ahbari A, Stour L, Agoumi A (2017) The dam reservoir of Bin El Ouidane (Azilal, Morocco) face to climate change. *Int J Sci Eng Res* 8(5):199–203. <https://doi.org/10.14299/ijser.2017.05.013>
- Ahbari A, Stour L, Agoumi A et al (2018a) Estimation of initial values of the HMS model parameters: application to the basin of Bin El Ouidane (Azilal, Morocco). *J Mater Environ Sci* 9(1):305–317. <https://doi.org/10.26872/jmes.2018.9.1.34>
- Ahbari A, Stour L, Agoumi A et al (2018b) Sensitivity of the HMS model to various modelling characteristics: case study of Bin El Ouidane basin (High Atlas of Morocco). *Arab J Geosci* 11:549. <https://doi.org/10.1007/s12517-018-3911-x>
- Ahbari A, Stour L, Agoumi A et al (2018c) A simple and efficient approach to predict reservoir settling volume: case study of Bin El Ouidane reservoir (Morocco). *Arab J Geosci* 11:591. <https://doi.org/10.1007/s12517-018-3959-7>
- Ahbari A, Stour L, Agoumi A (2019) Ability of the performance criteria to assess and compare reservoir management approaches. *Water Resour Manag* 33(4):1541–1555. <https://doi.org/10.1007/s11269-019-2201-z>
- Bannister D, Herzog M, Graf HF et al (2017) An assessment of recent and future temperature change over the Sichuan Basin, China, using CMIP5 climate models. *J Clim* 30(17):6701–6722. <https://doi.org/10.1175/JCLI-D-16-0536.1>
- Borison A, Hamm G (2008) Real options and urban water resource planning in Australia. Water Services Association of Australia occasional paper (20). Water Services Association of Australia, Melbourne
- Brient F (2020) Reducing uncertainties in climate projections with emergent constraints: concepts, examples and prospects. *Adv Atmos Sci* 37:1–15. <https://doi.org/10.1007/s00376-019-9140-8>
- Brown C, Ghile Y, Laverty M et al (2012) Decision scaling: linking bottom-up vulnerability analysis with climate projections in the water sector. *Water Resour Res* 48:W09537. <https://doi.org/10.1029/2011WR011212>
- Bucchignani E, Cattaneo L, Panitz H-J et al (2016) Sensitivity analysis with the regional climate model COSMO-CLM over the CORDEX-MENA domain. *Meteorog Atmos Phys* 128(1): 73–95. <https://doi.org/10.1007/s00703-015-0403-3>
- Bussi G, Francés F, Horel E et al (2014) Modelling the impact of climate change on sediment yield in a highly erodible Mediterranean catchment. *J Soils Sediments* 14:1921–1937. <https://doi.org/10.1007/s11368-014-0956-7>



- Cohen JL, Furtado JC, Barlow MA et al (2012) Arctic warming, increasing fall snow cover and widespread boreal winter cooling. *Environ Res Lett* 7:014007. <https://doi.org/10.1088/1748-9326/7/1/014007>
- Condie SA, Webster IT (1997) The influence of wind stress, temperature, and humidity gradients on evaporation from reservoir. *Water Resour Res* 33(12):2813–2822
- Duan Q, Phillips TJ (2010) Bayesian estimation of local signal and noise in multimodel simulations of climate change. *J Geophys Res* 115:D18123. <https://doi.org/10.1029/2009JD013654>
- Fantini A, Raffaele F, Torma C et al (2018) Assessment of multiple daily precipitation statistics in ERA-interim driven med-CORDEX and EURO-CORDEX experiments against high resolution observations. *Clim Dyn* 51:877–900. <https://doi.org/10.1007/s00382-016-3453-4>
- Filahi S, Trambly Y, Mouhir L et al (2017) Projected changes in temperature and precipitation in Morocco from high-resolution regional climate models. *Int J Climatol* 37(14):4846–4863
- Giorgi F, Jones C, Asrar G (2009) Addressing climate information needs at the regional level: the CORDEX framework. *World Meteorol Organ Bull* 58:175–183
- Giorgi F, Raffaele F, Coppola E (2019) The response of precipitation characteristics to global warming from climate projections. *Earth Syst Dynam* 10:73–89. <https://doi.org/10.5194/esd-10-73-2019>
- Hashimoto T, Stedinger JR, Loucks DP (1982) Reliability, resiliency, and vulnerability criteria for water resource system performance. *Water Resour Res* 18(1):14–20. <https://doi.org/10.1029/WR018i001p00014>
- Hausfather Z, Peters GP (2020) Emissions – the ‘business as usual’ story is misleading. *Nature* 577:618–620
- Hawkins E, Sutton R (2009) The potential to narrow uncertainty in regional climate predictions. *Bull Am Meteorol Soc* 90:1095–1107. <https://doi.org/10.1175/2009BAMS2607.1>
- IPCC (2014) Working group I contribution to the IPCC fifth assessment report climate change (2014) the physical science basis. Cambridge University Press, Cambridge, UK/New York
- Jiang D, Tian Z, Lang X (2015) Reliability of climate models for China through the IPCC third to fifth assessment reports. *Int J Climatol* 36(3):1114–1133. <https://doi.org/10.1002/joc.4406>
- Koutsouris AJ, Destouni G, Jarsjö J et al (2010) Hydro-climatic trends and water resource management implications based on multi-scale data for the Lake Victoria region, Kenya. *Environ Res Lett* 5:034005
- Lepinas F, Ludwig W, Heussner S (2014) Hydrological and climatic uncertainties associated with modeling the impact of climate change on water resources of small Mediterranean coastal rivers. *J Hydrol* 511:403–422. <https://doi.org/10.1016/j.jhydrol.2014.01.033>
- Looks DP (1997) Quantifying trends in system sustainability. *Hydrol Sci J* 42(4):513–530. <https://doi.org/10.1080/02626669709492051>
- Marzeion B, Kaser G, Maussion F et al (2018) Limited influence of climate change mitigation on short-term glacier mass loss. *Nat Clim Change* 8:305–308. <https://doi.org/10.1038/s41558-018-0093-1>
- McMahon TA, Adeloje AJ, Sen-Lin Z (2006) Understanding performance measures of reservoirs. *J Hydrol* 324:359–382. <https://doi.org/10.1016/j.jhydrol.2005.09.030>
- McSweeney C, New M, Lizcano G (2010) UNDP climate change country profiles: Morocco. <http://country-profiles.geog.ox.ac.uk/>. Accessed 18 Dec 2018
- Means E, Laugier M, Daw J (2010) Decision support planning methods: incorporating climate change uncertainties into water planning. Water Utility Climate Alliance White Paper. <https://www.wucaonline.org/assets/pdf/pubs-whitepaper-012110.pdf>. Accessed 10 May 2020
- MEMEE (2016) 3ème Communication Nationale du Maroc à la Convention Cadre des Nations Unies sur les Changements Climatiques. <http://unfccc.int/resource/docs/natc/marn3.pdf>. Accessed 18 Dec 2018
- Morgan M, Dowlatabadi H, Henrion et al (2009) U.S. Climate Change Science Program. Synthesis and assessment product 5.2. Best practice approaches for characterizing, communicating and incorporating scientific uncertainty in climate decision making. [https://keith.seas.harvard.edu/files/tkg/files/sap\\_5.2\\_best\\_practice\\_approaches\\_for\\_characterizi.pdf](https://keith.seas.harvard.edu/files/tkg/files/sap_5.2_best_practice_approaches_for_characterizi.pdf). Accessed 10 May 2020

- Nassopoulos H, Dumas P, Hallegatte S (2012) Adaptation to an uncertain climate change: cost benefit analysis and robust decision making for dam dimensioning. *Clim Chang* 114:497–508. <https://doi.org/10.1007/s10584-012-0423-7>
- Osuch M, Wawrzyniak T (2016) Inter- and intra-annual changes in air temperature and precipitation in western Spitsbergen. *Int J Climatol* 37(7):3082–3097. <https://doi.org/10.1002/joc.4901>
- Oudin L, Hervieu F, Michel C et al (2005) Which potential evapotranspiration input for a lumped rainfall–runoff model? Part 2 – towards a simple and efficient potential evapotranspiration model for rainfall–runoff modelling. *J Hydrol* 303(1–4):290–306. <https://doi.org/10.1016/j.jhydrol.2004.08.026>
- Ouraich I (2014) Agriculture, climate change, and adaptation in Morocco: a computable general equilibrium analysis. PhD thesis, Purdue University
- Phillips TJ, Gleckler PJ (2006) Evaluation of continental precipitation in 20th century climate simulations: the utility of multimodel statistics. *Water Resour Res* 42(3):W03202. <https://doi.org/10.1029/2005WR004313>
- Räty O, Räisänen J, Bosshard T et al (2018) Intercomparison of univariate and joint bias correction methods in changing climate from a hydrological perspective. *Climacteric* 6:33. <https://doi.org/10.3390/cli6020033>
- Sandoval-Solis S, McKinney DC, Loucks DP (2011) Sustainability index for water resources planning and management. *J Water Resour Plan Manag* 137(5):381–390. [https://doi.org/10.1061/\(ASCE\)WR.1943-5452.0000134](https://doi.org/10.1061/(ASCE)WR.1943-5452.0000134)
- Santer BD, Po-Chedley S, Zelinka MD et al (2018) Human influence on the seasonal cycle of tropospheric temperature. *Science* 361(6399):eaas8806. <https://doi.org/10.1126/science.aas8806>
- Schliep EM, Cooley D, Sain SR et al (2010) A comparison study of extreme precipitation from six different regional climate models via spatial hierarchical modeling. *Extremes* 13:219–239
- Sellami H, Benabdallah S, La Jeunesse I et al (2016) Quantifying hydrological responses of small Mediterranean catchments under climate change projections. *Sci Total Environ* 543(B):924–936. <https://doi.org/10.1016/j.scitotenv.2015.07.006>
- Singh VL, Jain SK, Singh PK (2019) Inter-comparisons and applicability of CMIP5 GCMs, RCMs and statistically downscaled NEX-GDDP based precipitation in India. *Sci Total Environ* 697:134163. <https://doi.org/10.1016/j.scitotenv.2019.134163>
- Teutschbein C, Seibert J (2012) Bias correction of regional climate model simulations for hydrological climate-change impact studies: review and evaluation of different methods. *J Hydrol* 12(29):456–457. <https://doi.org/10.1016/j.jhydrol.2012.05.052>
- Tofiq FA, Guven A (2014) Prediction of design flood discharge by statistical downscaling and general circulation models. *J Hydrol* 517:1145–1153. <https://doi.org/10.1016/j.jhydrol.2014.06.028>
- Van Vuuren DP, Edmonds J, Kainuma M et al (2011) The representative concentration pathways: an overview. *Clim Chang* 109:5–31. <https://doi.org/10.1007/s10584-011-0148-z>
- von Trentini F, Leduc M, Ludwig R (2019) Assessing natural variability in RCM signals: comparison of a multi model EURO-CORDEX ensemble with a 50-member single model large ensemble. *Clim Dyn* 53:1963–1979. <https://doi.org/10.1007/s00382-019-04755-8>
- Zhang W, Liuab P, Wangac H et al (2017) Reservoir adaptive operating rules based on both of historical streamflow and future projections. *J Hydrol* 553:691–707. <https://doi.org/10.1016/j.jhydrol.2017.08.031>

**Open Access** This chapter is licensed under the terms of the Creative Commons Attribution 4.0 International License (<http://creativecommons.org/licenses/by/4.0/>), which permits use, sharing, adaptation, distribution and reproduction in any medium or format, as long as you give appropriate credit to the original author(s) and the source, provide a link to the Creative Commons license and indicate if changes were made.

The images or other third party material in this chapter are included in the chapter's Creative Commons license, unless indicated otherwise in a credit line to the material. If material is not included in the chapter's Creative Commons license and your intended use is not permitted by statutory regulation or exceeds the permitted use, you will need to obtain permission directly from the copyright holder.





# Urban Flooding, Adaptation Strategies, and Resilience: Case Study of Accra, Ghana

# 115

Kwadwo Owusu and Peter Bilson Obour

## Contents

Introduction .....	2388
Accra's Vulnerability to Perennial Floods .....	2389
Description of the Study Area and Methodology .....	2390
Results and Discussion .....	2394
Impact of Flooding on Socio-economic Livelihoods .....	2394
Flood Control and Adaptation Measures .....	2395
Summary Types of Adaptation Measures to Flooding in Accra .....	2397
Limits and Barriers to Adaptation to Flooding .....	2399
Conclusions and Perspectives .....	2400
References .....	2401

## Abstract

Despite massive flood controlling investments, perennial flooding continues to be a major challenge in the Greater Accra Metropolitan Assembly in Ghana. Previous studies have mostly considered the vulnerability of Accra to flooding induced by urbanization and climate change. This chapter examined the impacts of and adaptation strategies to flooding in two flood-prone residential areas in Accra. A survey was conducted among 320 household heads to ascertain local impacts of floods and community adaptation strategies. To obtain a broader picture of government interventions and challenges, key stakeholders such as personnel from ministries, departments, and agencies who are involved in city planning, and

This chapter was previously published non-open access with exclusive rights reserved by the Publisher. It has been changed retrospectively to open access under a CC BY 4.0 license and the copyright holder is "The Author(s)". For further details, please see the license information at the end of the chapter.

K. Owusu · P. B. Obour (✉)

Department of Geography and Resource Development, University of Ghana, Legon, Ghana  
e-mail: [kowusu@ug.edu.gh](mailto:kowusu@ug.edu.gh); [pbobour@ug.edu.gh](mailto:pbobour@ug.edu.gh)

© The Author(s) 2021

W. Leal Filho et al. (eds.), *African Handbook of Climate Change Adaptation*,  
[https://doi.org/10.1007/978-3-030-45106-6\\_249](https://doi.org/10.1007/978-3-030-45106-6_249)

2387

private urban planning consultants were interviewed. The study found that a notable driver of floods in Accra is blocked waterways, and flawed and ad hoc engineering works. About three-quarters of the households interviewed have suffered flood-related losses over the past decade such as housing damage, income, and even a death of a relative. Key flood control interventions included dredging prior to start of rains and sporadic demolition of unauthorized buildings on or near waterways to allow free flow of water. However, these interventions only seem to be ephemeral due to the rapid rate of littering and re-siltation of the waterways after few rain events. The study highlights the need for more pragmatic and robust engineering solutions to build resilience of Accra to floods.

---

**Keywords**

Barriers to adaptation · Flood control interventions · Perennial flooding · Socio-economic livelihoods

---

**Introduction**

Urban flooding is one of the major hydro-climatic disasters which is increasing in frequency and intensity and affecting regions worldwide. Flooding causes serious economic, social, health, cultural, and environmental impacts that affect sustainable development (Kim et al. 2017), particularly in developing regions because of high poverty levels, and poor urban planning and building architecture. Different types of floods can be identified based on the source of water and the process giving rise to the flooding event (Viglione and Rogger 2015). This study focuses on urban floods occurring independently and/or in conjunction with flash and river floods. As at the year 2000, global urban land susceptible to floods was estimated to be around 195,493 km<sup>2</sup> (Güneralp et al. 2015). Africa is one of the continents highly affected by flood-induced disasters, particularly in urban areas. The vulnerability of African cities to urban flooding is partly due to the fast rate of uncontrolled urbanization and its associated problems which constrained flow of water (Amoako 2012; Aboagye 2012; Dewan 2015).

In Ghana, flooding is among the top 10 natural disasters and hazards and ranks second after epidemics such as bacterial and viral infectious diseases, affecting over three million people and causing huge economic losses each year (Okyere et al. 2012). The country has experienced increasing flood events over the years – the severest floods in the last two decades occurred in the years 2007, 2010, 2011, 2015, and 2020, which hit many parts of the country, particularly major urban areas. For instance, on June 22, 2010, 35 bodies were retrieved from flood waters across the country by volunteers and rescue workers (Daily Graphic 5 June, 2015), and on June 3, 2015, flooding with an associated fire killed about 200 people in the commercial hub of Accra (BBC 2015). The consequences of flood-induced disasters in urban areas include loss of properties and lives as outlined above, which also have short- and long-term adverse consequences on urban poverty and development.

Global climate change impacts are likely to increase hydro-climatic disasters like flooding in urban areas. The recent Intergovernmental Panel on Climate Change (IPCC) Special Report on the impacts of global warming of 1.5 °C above preindustrial levels and related global greenhouse gas emission pathways projects increase in the frequency and magnitude of flood due to changing precipitation patterns (IPCC 2018). Despite the large uncertainties in the magnitudes of climate change impacts on water-related shocks, increased frequency of extreme rainfall events will pose a serious threat to urban resilience and sustainability in many developing countries. The high vulnerability of these regions to extreme climatic events results from their low resilience and weak adaptive capacity (IPCC 2007). Adaptation to flood-related impact is not an option but a necessity, which must be embraced across all spheres of planning. However, while the vulnerability of urban areas to flood-related disasters is largely studied, the local impacts and, more importantly, multilevel flood adaptation strategies are poorly understood especially in developing countries.

To contribute to a better understanding of climate change impact on urban areas in Ghana to disasters, and identify key adaptation challenges to guide decision making and for prioritizing city planning needs, a study was conducted in two flood-prone coastal metropolitan areas of Accra and Sekondi-Takoradi. Part of the results recently published by Owusu et al. (2019) investigated the physical and social vulnerability of the two urban cities to climate-induced disasters. Key findings highlight the need to prioritize perennial flooding to safeguard lives and property and to strengthen the cities' resilience to flood-related disasters. Following up on the previous findings by Owusu et al. (2019), the present chapter investigates incidence of flooding, adaptation strategies, and resilience in Accra. Specifically, the study (i) examined impact of floods on socio-economic livelihoods and (ii) explores multi-level flood control measures and adaptation strategies, and associated shortfalls, that is, why interventions to tackle flooding in Accra have been ineffective? It is hoped that a better understanding of flood control measures and adaptation practices and pitfalls would provide essential information on successful adaptation options and help to identify the interventions that need to be improved to build the resilience of Accra and other cities in Ghana to flood-related disasters.

---

## **Accra's Vulnerability to Perennial Floods**

The term vulnerability has been used by different authors to connote different meanings. Beyond the multidimensional usage of the term vulnerability, most comprehensive and accepted definition in the context of climate change has been given by the IPCC (2000) as: "the degree to which a system is susceptible to, or unable to cope with adverse effects of climate change, including climate variability and extremes." Thus, vulnerability of any system has generally been accepted as a function of three elements: exposure to a hazard, sensitivity to that hazard, and the capacity of the system to cope with and adapt or recover from the effects of those conditions (Jamshidi et al. 2019). Here, vulnerability is used to encompass both the exposure and susceptibility of population to floods. Thus, the chapter examines the

exposure of residents in Accra to flooding and the ensuing burden on socio-economic livelihoods and sustainable development in the city.

Accra is a primate city in Ghana with a long history of flood-related disasters as illustrated in Table 1. Records of major flood incidence in the city date back to June 1959 (Daily Graphic 5 June, 2015). More than 16 deadly flood disasters have been recorded since 1959, all of which have caused severe damages to life and property. The vulnerability of Accra to flooding has been attributed to natural factors and processes like its low-lying topography, increase rate of coastal erosion, frequency of torrential rainfall in recent years, combined with anthropogenic factors such as rapid urbanization, choked drains, and blocked watercourses (Jamshidi et al. 2019; Asumadu-Sarkodie et al. 2015; Appeaning Addo and Appeaning Addo 2016). For instance, on July 3, 1995, the Ghana Meteorological Agency (GMet) recorded 243 mm of rain with a peak intensity of 64 mm in 12 min. The rain lasted for approximately 5 h resulting in flooding in Accra and its environs (Kwarteng 2007) and on May 18, 2008, and October 25, 2011, ~156 mm of rain water was recorded in less than 10 h resulted in a deadly flood in many parts of Accra (The Weekend Globe 2013). According to Maskey and Trambauer (2015), the main process leading to flooding is precipitation falling over an extended period of time in an area which produces runoff due to saturation (antecedent soil moisture) and excess infiltration. The relationship between heavy downpours and incidence of flooding (due to rapid peak flows) has been explained using run-off models (e.g., Asumadu-Sarkodie et al. 2015). Jahanbazi and Egger (2014) stress that extreme rainfall leads to flooding when urban drainage system fails to drain the total amount of rainwater, resulting in what could be termed as an urban pluvial.

Considering that changes in precipitation patterns and extreme rainfall associated with climate change will increase the vulnerability of cities to flooding in many regions (Willems et al. 2012), flooding in Accra will continue to be a major socio-economic and development challenge more than ever. A better understanding of management of flooding and failures is vital to develop sustainable solutions and building the resilience in flood-prone areas in Accra.

---

## Description of the Study Area and Methodology

Accra is the largest metropolitan area in Ghana and has been the administrative capital city of the country since 1877. It has a total land area of 201 km<sup>2</sup> (UN-Habitat 2009). The city has experienced a rapid growth and it is one of the fastest-growing cities in West Africa with an estimated annual average growth rate (2010–2020) of 2.2% (www.macrotrends.net 2020). Accra has physically developed very quickly particularly along the arteries of the major road network radiating from the city center to the countryside (Møller-Jensen et al. 2005). Another worrying trend is the increasing physical development along the low-lying coastal and flood-prone areas of Accra threatening the ecology of coastal lagoons and estuaries (Owusu et al. 2019). The population in the city has increased from about 177,000 inhabitants in 1950s to about 2.5 million inhabitants by the close of 2019 (www.macrotrends.net

**Table 1** Magnitude of daily precipitation and flood events and the number of affected people in Accra (1959–2020)

Date	Precipitation-a day before floods (mm)	Precipitation-flood day (mm)	Monthly total (mm)	% of precipitation on flood day <sup>a</sup>	Number of people affected <sup>b</sup>	Reference
June 1959 <sup>c</sup>	–	192	–	–	–	
June 27, 1960	0	98	371	26	–	(Daily Graphic 2015)
September 29, 1963	0	97	190	51	–	
July 4, 1968 <sup>d</sup>	5	33	372	9	>1000	(Asumadu-Sarkodie et al. 2015)
June 22, 1973	0.3	175	411	43	–	
July 14, 1991	2	157	263	60	–	
July 3, 1995	0	244	274	89	>1000	(Kwarteng 2007)
June 13, 1997	38	114	353	32	1000s	(Asumadu-Sarkodie et al. 2015)
June 27, 2001	27	81	247	33	100,000	(Aboagye 2012; CNN World 2001)
June 9, 2002	0	123	421	29	~1500	(United Nations Office for the Coordination of Humanitarian Affairs (OCHA) 2002)
March 26, 2007	0	59	63	95	–	
May 18, 2008	0	151	395	38	–	
October 25, 2011	58	98	184	53	43,000	(The Weekend Globe 2013)
June 3, 2015 <sup>e</sup>	–	–	–	–	>10, 000	(Daily Graphic 5 June, 2015)
June 8, 2020	–	–	–	–	>50, 000	(Darko 2020)

Source of precipitation data: Ghana Meteorological Agency (GMet), Accra.

<sup>a</sup>Precipitation on the day of floods as a percentage of the monthly total precipitation (mm)

<sup>b</sup>People requiring immediate assistance during an emergency situation plus those injured and homeless

<sup>c</sup>Reported amount of rainfall from Daily Graphic (5 June, 2015)

<sup>d</sup>Precipitation of 148.3 mm was recorded 2 days before day of flood

<sup>e</sup>Flood ignited fire flames in a fuel station. Number of lives lost included victims killed by the fire



2020) and accommodates approximately 8.4% of the ~30 million people in Ghana. Unfortunately, infrastructure and service provision is behind the physical development of Accra and has placed pressure on housing and worsened the already high housing deficit in the city (Rain et al. 2011). As a result, there are many areas that are unplanned or where inadequate planning has been carried out by the land-owners who attempt to integrate their development into the statutory land use plan of Accra leading to a proliferation of slums with about 38% of the city's population living in these underserved settlements (UN-Habitat 2011).

The physical location of Accra in the dry coastal foothills of the Akwapim ranges renders the city vulnerable to flooding. Accra is mostly low lying with average elevation around 20 m and bordered by few hills to the west and northwest. It is drained by many rivers like the Odaw and Dzorwulu that originate from the Akwapim hills. Rainfall in the Southeast of Ghana where Accra is located has high variability (with coefficient of variation of above 30%) which results in high frequent of rainfall extremes (Owusu and Teye 2015). Two residential classes in Accra, namely, second and third areas prone to perennial flooding (Owusu et al. 2019), were selected for the study. The specific neighborhoods were: second class residential areas (Kaneshie, Abelemkpe, and Asylum Down) and third class residential areas (Adabraka, Alajo, Avenor, Odawna, Mataheko, Nima, and Mamobi). The vulnerability of the neighborhoods to flooding is partly due to the low-lying topography (lies a few meters above sea level) and uncontrolled slums (Owusu et al. 2019). The geographical spread of the study sites (Fig. 1) was to ensure that we obtained a wide and representative data.

Primary data for the study were collected using the procedure described in Owusu et al. (2019). In brief, data on impacts of flooding on household livelihoods, mitigations and adaptation strategies, and barriers were collected at household and institutional levels. A combination of stratified and simple random sample survey were conducted in the neighborhoods located in the two residential classes. A total of 320 household heads were interviewed, which comprised 90 and 230 in the second and third class residential areas, respectively. Data collected included background information, experience, and narration of impact of flooding in the area of residence and individual and/or community preparedness and response.

Interviews were conducted with construction engineers and relevant institutions such as the Departments of Physical Planning, Development Planning, Urban Roads, and National Disaster Management Organization (NADMO), Geological Survey Department, and the Ghana Water Company Limited (GWCL) in Greater Accra Metropolitan Assembly (AMA) to provide further insights into the household surveys and preparedness and flood-mitigation measures rolled out by the metropolis to control perennial flooding in Accra. To supplement the data on flood-mitigation measures in the Accra, secondary data collection was done to obtain information on past and current public (government) invested projects to tackle flooding and its associated impacts on socio-economic livelihoods on the population. The secondary

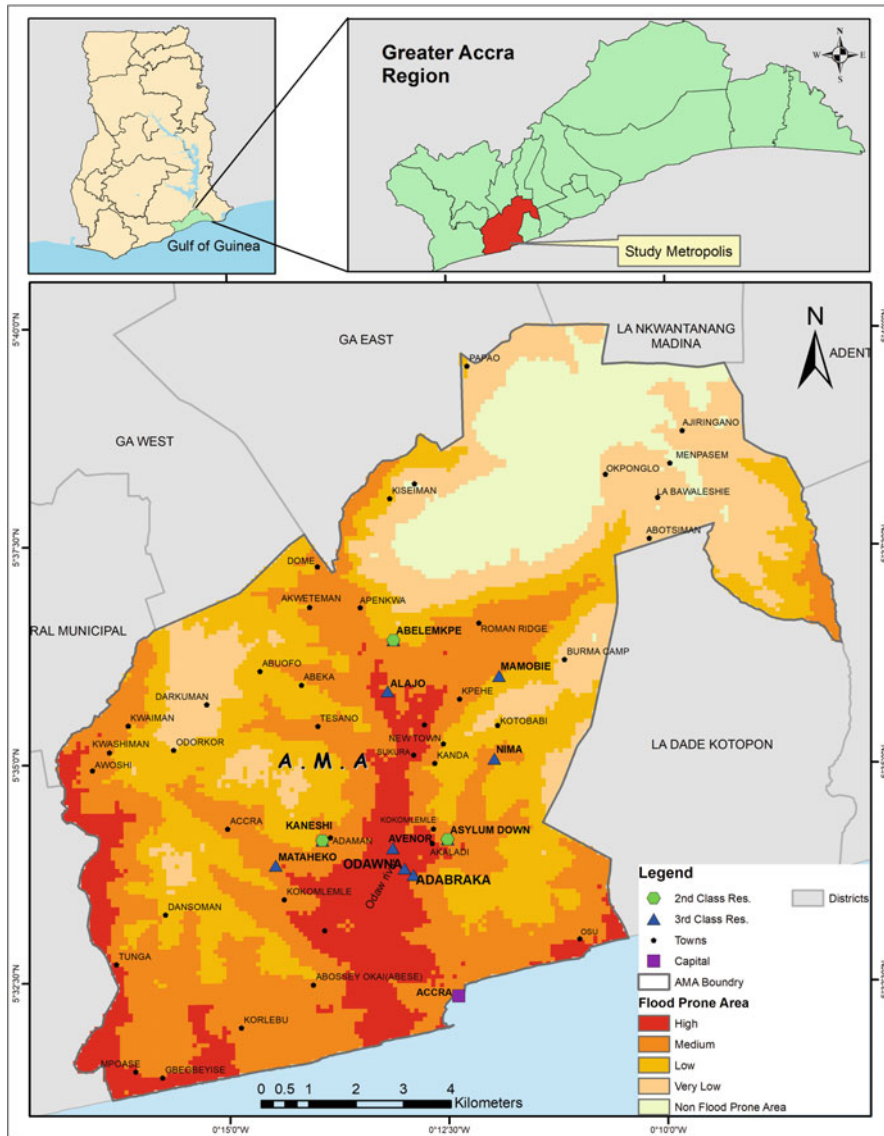


Fig. 1 Map of Accra showing the study locations and flood-prone areas. (Source: Authors)

data were sourced from newspapers, journal articles, and government documents. Both the primary and secondary data were manually analyzed to establish themes and patterns based on the objectives of the study.

## Results and Discussion

### Impact of Flooding on Socio-economic Livelihoods

Both the household and stakeholder interviews indicate that flooding has socio-economic tolls on households, the metropolitan assembly, and the nation. The impact on household livelihood reported included loss of property such as buildings and other personal belongings, and self-employed businesses. The respondents interviewed in both residential areas investigated revealed that property damage during flood varied considerably between households, ranging from hundreds to several thousands of dollars across households in the seven study sites. However, for poor record keeping and reluctance of the respondents in providing information on economic losses, exact monetary damages to household could not be ascertained. Nevertheless, the estimates reported in the present study corroborates the information sourced from stakeholders and what has been reported in earlier studies. Previous studies in Accra estimated property damage due to flooding in the city on July 3, 1995, and on June 13, 1997, ranged from thousands to millions of dollars (Kwarteng 2007; Aboagye 2012). Interviews held with NADMO officials showed that the nation spends a lot of money on flood events in AMA – it constitutes expenses on relief items like blanket, mattresses soap, food, and sometimes temporary structures for flooding affected households.

Results from the present study showed that the magnitude of flood-related damages and losses largely depended on household characteristics such as the economic value of personal belongings of affected-households, and more importantly, whether flood warning were issued prior to a flooding episode. The main source of information on risk of flooding reported by the respondents was flood alert warnings issued by the GMet. Thus, the interviews revealed that reported flood-induced damages were high among respondents who own several and/or valuable properties such as electronic appliances, furnished homes, and those who were engaged in self-employed business in the same neighborhood where they lived or in another flood-prone area in Accra. Further, results from the household interviews demonstrated that economic impact of floods in terms of property damage, in general, tends to be low when households anticipated risk of flooding during a rain storm/event from warnings issued by the GMet. In that case they were able to move some of their belongings to relatives and friends who lived in low flood risks areas in the city.

Further, physical destruction of buildings means household loss their homes. Over 65% of the respondents in both residential areas reported that they or someone they knew had been homeless for a few weeks to several months after flooding in the last decade. The respondents mentioned that being homeless has both economic and psychological consequences on their households, though the latter could not be readily quantified. According to a respondent: “. . .Being homeless, especially when you have a family makes you feel like you have life without soul or sailing without direction.”

In addition to property losses, all the respondents emphasized that flooding in Accra posed physical danger on lives and health of households, such as injuries on the day of flooding and an outbreak of cholera and other water-borne diseases after flooding. About 30% of the households, mainly in Alajo, Avenor, Odawna, and Adabraka, reported that they have lost a relative or someone they knew due to flood-related disasters in the past decade, probably due to the close proximity of the neighborhoods to the Odaw River which frequently overflows its banks during rainstorms. Cost of treating injuries immediately or a few days following flood-disasters was reported to be free of charge because AMA took care of the medical bills, whereas cases reported several days after flooding were not treated for free. This means “unless a patient is a national health insurance scheme participant, they have to pay for cost of health care services.” The present study demonstrates that the overall impacts of flooding on household livelihood in Accra may be higher than previously thought. According to Maskey and Trambauer (2015), hydro-climatic hazards have tangible impacts that are easily quantifiable and intangible that are not easily quantifiable. Owusu and Teye (2015) found that property loss and death associated with urban flooding in Accra could be remarkably high, but evaluation is limited by lack of data. It is interesting and relevant for future studies to map and quantify the actual socio-economic, health, and psychological burden of flooding on households in Accra using proxy data such as cost of treating injuries and/or disease morbidity, lost wages, time spent for caring for sick or injured household member, etc., to provide a robust documentation and clear picture of impact of floods. Such information can be very useful for prioritizing government- and private-led schemes for supporting flood-affected households in Accra.

## **Flood Control and Adaptation Measures**

Results from the interviews and detailed review of secondary literature demonstrating the detrimental impact of flooding on household livelihood and economic implications for the nation (e.g., Mensah and Ahadzie 2020; Ahmed et al. 2018) suggest that flood control in the short-term or adaptation in the long-terms is imperative. However, it is intriguing to point out that the long flood history of Accra has, indeed, shaped the interaction between local and/or metropolitan activities and development, and flood control and adaptation practices. In the following section, the individual and communities, and metropolitan flood control and adaptation interventions, as well as some pertinent barriers to adaptation, are discussed. To better understand the spatial dimensions of community interventions, that is, whether household flood control and/or adaptation strategies are influenced by their physical local or vulnerability to flooding, flood control, and/or adaptation strategies reported by the respondents are discussed in light of the two residential classes investigated.

## Individual and Community

Results indicated that individuals in the study areas are coping by adopting a combination of flood control and adaptation practices. For respondents who lived a few meters away from main drains, a key control measure reported was the digging of temporary channels from their homes to the main drain to ensure free flow of water during torrential rain event. However, the practices, in general, were reported to be less effective and less reliable because the main river channel is often choked.

Eighty-five percent of the respondents in marginal areas like flood plains and swampy areas indicated that they have adapted to flooding by taken drastic accommodation steps. The key reported ones included: (i) changing from building expensive permanent concrete block structures to building cheaper temporary structures such as simple wood structures or metal containers. Fifty-eight percent of the respondents who lived in temporary structures held the opinion that living in those structures were necessary to alleviate huge capital losses when the structure is damaged or lost due either to demolition exercises periodically carried out by AMA to bring down unauthorized structures on and near waterways, or the structure is damaged during flooding. (ii) The respondents in both residential classes reported that they also controlled flooding by desilting drainage channels in their neighborhoods. The cost of dredging is sometimes fully supported by AMA through the local assembly. However, they emphasized that such a support was not regular. Therefore, the common practice has been organizing communal labor to dredge some of the sections of the drainage channels themselves. Further, the interviews revealed a few relatively rich individuals in both residential areas sometimes employed the services of private dredging companies to desilt all or a section of drainage channels closed to their homes to allow free flow of water, which helps prevent flooding. (iii) Another individual adaptation practice reported by 52% and 48% of the respondents in the third and second class residential areas was temporary vacation of homes located on and near waters during the rainy season, especially when the GMet issued an alert that flooding in Accra was imminent. Findings are consistent with previous observations (e.g., Mensah and Ahadzie 2020) showing that in flood-prone areas, people adopt reactive strategies like relocating and protecting properties, for instance, by practicing early transfer of personal belongings to safe places prior to onset of rains. The present study further showed that flood-forecasting by the GMet plays a crucial role in strengthening household seasonal adaptation practices and thus, helps to alleviate the negative impact of flooding on socio-economic livelihoods.

Households in the highly flood-prone residential areas, particularly in Alajo, Adabraka, Avenor, and Asylum Down, have adapted to the economic shocks of flooding by enrolling in life and property insurance schemes, which according to them provided an economic cushion in times of flood-related disasters. However, because premiums and monthly charges can be prohibitively expensive for, especially, low-income households, only a few of the respondents (18%) reported that they had life and/or property insurance.

## Metropolitan Assembly/Government

The household and stakeholder interviews pointed out two key areas of institutional or government ‘action plans’ to managing flooding in Accra. A common approach, which has for many decades been adopted by AMA, was routine dredging of water channels, notably the Odaw River and Korle-Lagoon. The Odaw River has a wide catchment area and covers most parts of Accra and feeds into the Korle-Lagoon, which empties the content of the Odaw and other drainage channels into the Gulf of Guinea (Owusu Boadi and Kuitunen 2002; Ministry of Works and Housing 2019). Table 2 presents an overview of government flood control and adaptation projects in Accra in the last decade implemented during the rainy season before or after flood disasters. Table 2 illustrates two important considerations: (i) the state has spent substantial amount of money in the past decade on measures to prevent flooding in Accra, and (ii) flood prevention measures have mainly been dredging to unblock major waterways and drainage systems prior to the rainy season. Findings of the study highlight that although the dredging projects required massive capital investment, the persistence of flooding in Accra is a strong evidence that the project may be providing ad hoc solutions with very minimal long-term impacts as previously reported by Owusu et al. (2019). Evidence here suggests a need for government to rather consider massive capital investments such as the construction of more robust drain, which can offer sustainable solutions for controlling flooding in Accra and in other flood-prone cities in Ghana.

Another institutional intervention reported was the demolition of unauthorized buildings on or near waterways to allow free flow of water. Demolition of building is an exercise regularly carried out by AMA prior to the start of the rainy season, especially when torrential rains were expected in Accra and its surroundings. The interviews revealed that likewise dredging, demolition also only offers a short-term solution for managing flooding because the demolished structures are re-erected shortly after the AMA-led demolition exercise is completed.

## Summary Types of Adaptation Measures to Flooding in Accra

Alcamo and Olesen (2012) proposed that climate change adaptation measures could be classified into the following: autonomous vs. planned, anticipatory vs. reactive, centralized vs. decentralized, and gradual vs. abrupt. Although these classifications were originally proposed in relation to climate change, they could be applied in the present study to classify the adaptation measures to flooding. Results showed that adaptation at the individual level encompasses both autonomous and planned adaptation practices. Decisions taken by households on where to relocate to when flood warnings are issued by GMet are mainly taken at the family level. The planned adaptation measures adopted by the individual included the construction of improvised channels from homes to main drains to ensure free flow of water. Dredging of drainage channels by community and/or government prior to the onset of rain is both anticipatory (i.e., in anticipation to control risk of flooding during the rainy season)

**Table 2** Overview of government investments (2010–2020) to control flooding in the Greater Accra Metropolitan Assembly

Project	Date (period)	Description	Cost (US\$)	Sponsors	Reference
Greater Accra Resilient and Integrated Development Project	2019–2025	Phase 1: mitigating the flood risk for a 10% annual exceedance probability flood in the Odaw River Basin	200 million	Dutch Government and the World Bank	The World Bank (2019)
		Phase 2: expanding flood mitigation and drainage improvements to additional priority basins (such as Lafa, Sakumo, Kpeshie, and Densu asins)	300 million	Dutch Government and the World Bank	The World Bank (2019)
		Phase 3: scaling up the project to the remaining priority basins of the Greater Accra Region (GAR) to mitigate flood risk in the entire GAR	400 million	Dutch Government and the World Bank	The World Bank (2019)
Korle Lagoon Ecological Restoration Project	2015–2016	Dredged the Odaw drain and Korle Lagoon to solve the perennial flooding in Accra in order to save lives and property	10 million	–	Arthur-Mensah (2017)
Relief and Repair Project	2015	A relief and repair efforts following flooding with an associated fire killed about 200 people in the commercial hub of Accra	12 million	Government of Ghana	The Economist Group (June 23rd 2016)
Accra Sanitation, Sewer, Stormwater and Drainage Alleviation Project	2013	Improving the drainage system in Accra to control the perennial flooding and sanitation challenges in the city	595 million	Loan facilities with the EXIM Bank of the USA and Standard Chartered Bank	BBC (2015)
Dredging the Odaw River	2011	Improving the drainage system of the Odaw	1.2 million	–	The Daily Graphic (2012)
Dredging Committee for Chemu Lagoon	2010	Improving the drainage system of the Chemu	2 million	–	Business Ghana (2010)

and reactive (i.e., to avoid similar flood-related damages and loss experienced during previous floods). Centralized adaptation measures to flooding in Accra encompass AMA or government sponsored projects carried out to dredge principal drainage channels; the commonly reported were the Odaw River and Korle-Lagoon. The decentralized adaptation measures involved dredging minor drainage channels sponsored through community fundraising. Finally, gradual adaptation measures to flooding are evidenced by the individual's decision to change from building more permanent and expensive homes on or near principal waterways to avert high economic losses when the structures are damaged due to flooding or government demolition. Further, as mentioned previously, a few of the respondents have adopted gradual adaptation strategy by enrolling in life and property insurance schemes against accidents and life-threatening disasters. Conversely, AMA- or government-led demolition of structures before onset of rains to reduce risk of flooding and associated damages and casualties is mainly an abrupt adaptation measure.

### Limits and Barriers to Adaptation to Flooding

A notable limitation to individual and community funded dredging reported was noncooperation and noncompliance among some community members. It was reported that, often, people are unwilling to contribute financially to enable the community leaders hire the services of private dredging companies. A major reason cited for noncontribution was “to some people this whole dredging activities is the responsibility of the local assembly and the government” [An assembly man at



**Fig. 2** (a) Location of residential buildings near open drainage and (b) excavation and disposition of dredged materials to drainage banks, which lead to rapid re-siltation and increases flood risk in Accra



Alajo]. Therefore, there was no need for the individual to take over what the government must do for the community or city.

Further, despite community and/or government massive investments in dredging and related projects, the impact of these projects, in general, seemed to be short-lived because as illustrated in Fig. 2, (i) the open drain system results in faster accumulation of silt and solid waste, (ii) the dredged materials are often left on the banks of the drainage, which leads re-siltation of the waterways after few rain events, (iii) lack of enforcement of town plans and building permits, and (iv) there is also a societal habitat of massive littering and disposing of domestic and industrial waste into drains, leading to rapid refilling of dredged drainage channels. According to Mensah and Ahadzie (2020), improper urban disposal of waste can heighten flood events. Findings here suggest a need for AMA to invest in the construction of more robust drainage systems to build flood resilience in Accra. Interviews with planning and private urban planning consultants emphasized the urgent need for more sustainable development infrastructure in Accra and in other flood-prone cities, for example, by switching from open drain to close drainage system to abate using drainage channels as dumping sites.

---

## Conclusions and Perspectives

Findings illustrate the perennial flooding in Accra that continue to cause massive property damage and occasional loss of lives. The main cause of flooding in the city was found to be the siltation of the Korle-Lagoon and the Odaw River and its tributaries, the construction of houses on waterways, and flood plains due mainly to lax enforcement of building permits. The very nature of development, that is, the building of open drains coupled with poor sanitation attitude among residences, results in the blockage of drains in the city that accounts for most of the flood episodes. This is supported by the fact that the Accra plains where the city of Accra is located is actually the driest part of Ghana with average annual precipitation totally 800 mm yet Accra is the most flooded city in the country.

Findings showed that flooding in Accra has enormous adverse impacts on household income, property, and employment. The main adaptation measures at the level of the individual, community, and government include building less permanent and inexpensive structures to reduce economic cost of flood-induced damages, dredging of drains ahead of rainfall and demolishing of buildings on or near waterways. Nevertheless, the adaptation measures, in general, were reported to be ineffective to make the city resilient to flooding. A major contribution of the study is showing that flood forecasting by GMet plays a crucial role in mitigating the devastating impact of flooding on household socio-economic livelihoods in Accra. Findings also points to the need for city authorities to implement robust measures to make Accra more resilient to flood in the era of climate change. It is suggested that, in the short-term, effort of making sure that dredged materials are not deposited on the banks of the drainage channel to prevent rapid re-siltation is needed. The dredged material could be put into good use in construction and landfill. However, because of

high level of pollution, more studies on how safely to dispose of or potentially use the dredged material should be done. Long-term adaptation such as robust engineering solutions, for example, covering open drains and building of retention ponds that will reduce surface runoff in the city, should be considered. There are a few green spaces like the Achimota forest and large undeveloped land near the city that can be created as retention ponds to help solve the perennial flooding problem in Accra. A potential limitation of the study is that the conclusions presented in the present work are based on a sample size of 320 from 10 flood-prone neighborhoods. It is recommended that future similar studies are conducted in other flood-prone neighborhoods in Accra and elsewhere in Ghana to expand the present work to improve the generalization of the findings for spatial planning and interventions to alleviate impact of flooding on urban livelihoods.

---

## References

- Aboagye D (2012) Living with familiar hazards: flood experiences and human vulnerability in Accra, Ghana. *J Urban Res.* <https://doi.org/10.4000/articulo.2110>
- Ahmed F, Moors E, Khan MSA, Warner J, Terwisscha van Scheltinga C (2018) Tipping points in adaptation to urban flooding under climate change and urban growth: the case of the Dhaka megacity. *Land Use Policy* 79:496–506. <https://doi.org/10.1016/j.landusepol.2018.05.051>
- Alcamao J, Olesen JE (2012) Life in Europe under climate change. Wiley-Blackwell, Chichester
- Amoako C (2012) Emerging issues in urban flooding in African cities—the case of Accra, Ghana. Paper presented at the 35th AFSAAP annual conference proceedings 2012
- Appeaning Addo K, Appeaning Addo I (2016) Coastal erosion management in Accra: combining local knowledge and empirical research. *Jamba: J Disaster Risk Stud* 8(1). <https://doi.org/10.4102/jamba.v8i1.274>
- Arthur-Mensah G (2017) Government should pay contractors for dredging Odaw-MP. Ghana News Agency. Available at: <https://www.modernghana.com/news/780971/government-should-pay-contractors-for-dredging.html>. Accessed June 10, 2020
- Asumadu-Sarkodie S, Owusu PA, Rufangura P (2015) Impact analysis of flood in Accra, Ghana. *Adv Appl Sci Res* 6(9):53–78
- BBC (2015) Ghana petrol station inferno kills about 150 in Accra. BBC. <http://www.bbc.com/news/world-africa-33003673>. Accessed 5 June 2015
- Business Ghana (2010) Ghana inaugurates dredging committee for Chemu Lagoon, April 1, 2010
- CNN World (2001) Ghana floods leave thousands homeless. CNN.com, June 28, 2001
- Daily Graphic (2015) Flood disaster profile of Ghana since 1968. Daily Graphic, June 5, 2015
- Darko KA (2020) One dead as military, NADMO move to rescue Accra flood victims. 9 June 2020
- Dewan TH (2015) Societal impacts and vulnerability to floods in Bangladesh and Nepal. *Weather Clim Extremes* 7:36–42. <https://doi.org/10.1016/j.wace.2014.11.001>
- Güneralp B, Güneralp I, Liu Y (2015) Changing global patterns of urban exposure to flood and drought hazards. *Glob Environ Chang* 31:217–225. <https://doi.org/10.1016/j.gloenvcha.2015.01.002>
- IPCC (2000) IPCC special report on emissions scenarios. In: Nebojsa Nakicenovic RS (ed) Special report on emissions scenarios. Cambridge University Press, Cambridge, UK, p 612
- IPCC (2007) Climate change 2007: synthesis report. Contribution of Working Groups I, II and III to the fourth assessment report of the Intergovernmental Panel on Climate Change IPCC, Geneva
- IPCC (2018) Summary for policymakers. In: Masson-Delmotte V, Zhai P, Pörtner H-O, Roberts D, Skea J, Shukla PR, Pirani A, Moufouma-Okia W, Péan C, Pidcock R, Connors S, Matthews JBR, Chen Y, Zhou X, Gomis MI, Lonnoy E, Maycock T, Tignor M, Waterfield T (eds) Global

- warming of 1.5 °C. An IPCC special report on the impacts of global warming of 1.5 °C above pre-industrial levels and related global greenhouse gas emission pathways, in the context of strengthening the global response to the threat of climate change, sustainable development, and efforts to eradicate poverty. World Meteorological Organization, Geneva, 32 pp
- Jahanbazi M, Egger U (2014) Application and comparison of two different dual drainage models to assess urban flooding. *Urban Water J* 11(7):584–595. <https://doi.org/10.1080/1573062X.2013.871041>
- Jamshidi O, Asadi A, Kalantari K, Azadi H, Scheffran J (2019) Vulnerability to climate change of smallholder farmers in the Hamadan province, Iran. *Clim Risk Manag* 23:146–159. <https://doi.org/10.1016/j.crm.2018.06.002>
- Kim Y, Eisenberg DA, Bondank EN, Chester MV, Mascaro G, Underwood BS (2017) Fail-safe and safe-to-fail adaptation: decision-making for urban flooding under climate change. *Clim Chang* 145(3):397–412. <https://doi.org/10.1007/s10584-017-2090-1>
- Kwarteng EM (2007) Aftermath of floods. *Daily Graphic*, June, 23, pp 18
- Maskey S, Trambauer P (2015) Hydrological modeling for drought assessment. In: Paron P, Di Baldassarre G, Shroder JF (eds) *Hydro-meteorological hazards, risks, and disasters*, Hazards and disasters series. Elsevier, Amsterdam, pp 263–282
- Mensah H, Ahadzie DK (2020) Causes, impacts and coping strategies of floods in Ghana: a systematic review. *SN Appl Sci* 2(5):792. <https://doi.org/10.1007/s42452-020-2548-z>
- Ministry of Works and Housing (2019) Greater Accra Resilient and Integrated Development Project. The Environmental Impact Assessment [EIA] Study for the Dredging in The Odaw Basin, GARID
- Møller-Jensen L, Kofie RY, Yankson PWK (2005) Large-area urban growth observations – a hierarchical kernel approach based on image texture. *Geografisk Tidsskrift-Danish J Geogr* 105(2):39–47. <https://doi.org/10.1080/00167223.2005.10649538>
- Okyere CY, Yacouba Y, Gilgenbach D (2012) The problem of annual occurrence of floods in Accra: an integration of hydrological, economic and political perspectives. ZEF University of Bonn, Bonn
- Owusu Boadi K, Kuitunen M (2002) Urban Waste Pollution in the Korle Lagoon, Accra, Ghana. *Environmentalist* 22(4):301–309. <https://doi.org/10.1023/A:1020706728569>
- Owusu K, Teye KJ (2015) Supplementing urban water supply with rainwater harvesting in Accra, Ghana. *Int J Water Resour Dev* 31(4):630–639. <https://doi.org/10.1080/07900627.2014.927752>
- Owusu K, Yankson PWK, Asiedu AB, Tutu-Benefor T (2019) Climate change impacts on two coastal metropolitan areas in Ghana. In: *Climate change in Ghana. The human dimension*. Afram Publication (Ghana) Limited, Accra
- Rain D, Engstrom R, Ludlow C, Antos S (2011) Accra Ghana: a city vulnerable to flooding and drought-induced migration. UN-Habitat, Nairobi
- The Daily Graphic (2012) The dead Odaw River – polluted with plastics, garbage & human excreta. GhanaWeb. Mar 13, 2012. <http://www.ghanaweb.com/GhanaHomePage/>. The Daily Graphic
- The Economist Group (June 23rd 2016) One year on, Ghana floods again. Available: [http://country.eiu.com/article.aspx?articleid=1994343383&Country=Ghana&topic=Economy\\_1](http://country.eiu.com/article.aspx?articleid=1994343383&Country=Ghana&topic=Economy_1). Accessed June 15, 2020
- The Weekend Globe (2013) Danger: pollution of Odaw increases. <http://www.ghanaweb.com/GhanaHomePage/NewsArchive/Danger-Pollution-of-Odaw-increases-286634>. Accessed 25 June 2016
- The World Bank (2019) Greater Accra Resilient and Integrated Development Project (P164330)
- UN-Habitat (2009) Ghana: Accra urban profile. UN-Habitat, Regional and technical Co-operation Division, Nairobi
- UN-Habitat (2011) Housing profile. Nairobi
- United Nations Office for the Coordination of Humanitarian Affairs (OCHA) (2002) Ghana – floods OCHA, Accra
- Viglione A, Rogger M (2015) Flood processes and hazards. In: Paron P, Di Baldassarre G, Shroder JF (eds) *Hydro-meteorological hazards, risks, and disasters*. Hazards and disasters series. Elsevier, Amsterdam, pp 3–33

Willems P, Arnbjerg-Nielsen K, Olsson J, Nguyen VTV (2012) Climate change impact assessment on urban rainfall extremes and urban drainage: methods and shortcomings. *Atmos Res* 103:106–118. <https://doi.org/10.1016/j.atmosres.2011.04.003>

www.macrotrends.net (2020) Accra, Ghana metro area population 1950–2020. <https://www.macrotrends.net/cities/21107/accra/population#:~:text=Chart%20and%20table%20of%20population,a%201.58%25%20increase%20from%202019>

**Open Access** This chapter is licensed under the terms of the Creative Commons Attribution 4.0 International License (<http://creativecommons.org/licenses/by/4.0/>), which permits use, sharing, adaptation, distribution and reproduction in any medium or format, as long as you give appropriate credit to the original author(s) and the source, provide a link to the Creative Commons license and indicate if changes were made.

The images or other third party material in this chapter are included in the chapter's Creative Commons license, unless indicated otherwise in a credit line to the material. If material is not included in the chapter's Creative Commons license and your intended use is not permitted by statutory regulation or exceeds the permitted use, you will need to obtain permission directly from the copyright holder.





# Barriers to Effective Climate Change Management in Zimbabwe's Rural Communities

# 116

Louis Nyahunda and Happy Mathew Tirivangasi

## Contents

Introduction and Background .....	2406
Barriers to Effective Climate Change Management in Zimbabwe's Rural Communities ....	2408
Overview of Climate Change Management .....	2409
Climate Change Management Efforts at National Level in Zimbabwe .....	2411
Climate Change Management Strategies at Local Levels .....	2412
Determinants of the Ability to Adapt to Climate Change (Adaptive Capacity) .....	2416
Economic Resources .....	2417
Training and Awareness .....	2417
Social Capital .....	2418
Equity .....	2418
Availability of Technology .....	2419
Availability of Infrastructures .....	2419
Availability of Institutions .....	2419
Barriers Towards Effective Climate Change Management in Zimbabwe's Rural Communities .....	2420
Poverty .....	2420
Inadequate Information about Climate Change and Adaptation .....	2421
Lack of Adequate Institutions that Support Adaptation .....	2423
Gender Inequalities .....	2424
Inadequate Extension Services .....	2425
Outbreak of Health Emergencies .....	2426

This chapter was previously published non-open access with exclusive rights reserved by the Publisher. It has been changed retrospectively to open access under a CC BY 4.0 license and the copyright holder is "The Author(s)". For further details, please see the license information at the end of the chapter.

L. Nyahunda (✉)

Department of Social Work, University of Limpopo, Polokwane, South Africa

H. M. Tirivangasi

Department of Research Administration and Development, University of Limpopo, Polokwane, South Africa

e-mail: [happy.tirivangasi@ul.ac.za](mailto:happy.tirivangasi@ul.ac.za)

© The Author(s) 2021

W. Leal Filho et al. (eds.), *African Handbook of Climate Change Adaptation*, [https://doi.org/10.1007/978-3-030-45106-6\\_251](https://doi.org/10.1007/978-3-030-45106-6_251)

2405

Conclusion .....	2427
References .....	2428

### Abstract

The daunting effects of climate change are more visible and acute among rural people in most developing countries. Smallholder farmers in rural communities are more encumbered by climate change impacts and they have been reeling with climate induced shocks for some time. Their vulnerability to climate change impacts is aggravated by high dependence on the climate volatile natural resource base, high poverty levels, lack of adaptive capacity, low educational levels, and lack of technoscience-based technologies among other key compounding factors. In the light of this, Zimbabwe is still crawling to implement and administer effective climate change management measures aimed at disaster risk reduction and management, vulnerability reduction, social resilience, and capacity building because of political and socioeconomic quagmires trapping the country. Consequently, rural people are the hardest hit by these developments. Climate change management connotes a human intervention to reduce the sources or enhance the sinks of greenhouse gases and adjustment to actual or expected climate and its effects, in order to moderate harm or exploit beneficial opportunities through mitigation and adaptation. Nevertheless, rural people are on record of engaging in a plethora of activities to manage climate change and its actual or potential risks. However, their efforts are marred by an avalanche of setbacks which serve as barriers to climate change management. Against this backdrop, this book chapter intends to delineate the factors serving as barriers to climate change management in Zimbabwe's rural communities.

## Introduction and Background

Zimbabwe like many other developing countries is highly vulnerable to climate change impacts due to livelihoods that are climate sensitive. The country's vulnerability is also catalyzed by low adaptive capacities among its citizens (Zvamasiya et al. 2017). On that note, the multifarious impacts of climate change are visible and felt in different sectors which beacons the country's economy namely; agriculture, health, water resources, transport, energy, tourism, wildlife, and biodiversity (Dube and Nhamo 2019). The precarious impacts of climate change are taking a toll in rural communities where rainfed agriculture is a key livelihood factor. Furthermore, rural people are more vulnerable to climate change impacts because they lack adaptive capacity in the wake of climate change induced shocks (Nyahunda et al. 2019). In the light of this, Mubaya and Mafongoya (2017) opine that the manifestation of climate change impacts through erratic rainfall patterns and excessive temperatures is resulting in dwindling of crop yields placing rural people at a perilous position of food insecurity. As for Chanza (2014), due to climate change, rural communities have been saddled by successive droughts, desiccation of water sources, floods,

distribution of pathogens causing diseases and death of livestock, deterioration of the natural resource base including grazing lands for livestock, and widened poverty levels.

This chapter derives from empirical research on climate change adaptation among rural people in Chivi south and Umzingwane districts. It also benefited from a conceptual review of literature on climate change adaptation studies conducted in other rural parts of Zimbabwe. This was done to extract best adaptation practices and also to document the constraints faced by rural people in their adaptation efforts. In this regard, this is meant to inform policy measures that could be devised to circumvent adaptation constraints among rural people. For empirical purposes, the study was qualitative in nature guided by the multi-case study design. Data was collected through transect walks, focus group discussions and individual interviews with 40 participants that were purposively and conveniently selected in Chivi south and Umzingwane districts. In September 2019, the Government of Zimbabwe declared a national state of disaster over drought as crop yields dwindled owing to climate change. In response, the government appealed for international funding to cater for famine affecting more than 6.5 million people (Dube and Nhamo 2019). Matebeleland South and Masvingo provinces which were the focal point of this study were identified as the most vulnerable provinces to the vagary impacts of climate change (Phiri et al. 2014). These provinces are situated in the agro-ecological regions that are volatile to climate change. As such, agricultural production has been stymied by long dry spells, hot temperatures and erratic rainfall patterns owing to climate change (Jiri et al. 2017). Earlier studies conducted in Chivi south (Masvingo province) and Umzingwane (Matebeleland South province) districts revealed that climate change risks are rampant such as water stress, drought, increased incidences of pests and diseases, and death of livestock (Mudzonga 2012; Dube et al. 2016).

As mentioned above, Dube and Nhamo (2019) posit that among other precarious impacts of climate change is the successive episodes of drought seasons in Zimbabwe particularly in rural communities where an estimated number of seven million people were declared food insecure by September 2019. Despite the Zimbabwean government's acknowledgement of the impacts of climate change on its socio-economic sectors and vulnerable groups such as rural people, little has been done to cushion rural people and their livelihoods from the vagary impacts of climate change. As such, efforts to manage climate change and its impacts through broad-based adaptation and mitigation processes in rural communities are still far from being lived realities. In order to substantiate this exposition, this book chapter provides evidence of climate change impacts, response strategies and challenges faced by rural people in responding to climate change impacts in Umzingwane district in Matebeleland South Province and Chivi south district in Masvingo province of Zimbabwe. This shall be juxtaposed to the experiences of rural people in other parts of Zimbabwe where climate change is taking a toll. As elsewhere in rural Zimbabwe, smallholder farmers in Umzingwane and Chivi have been reeling with the impacts of climate change for some time complemented by a myriad of challenges to triumph over climate change impacts (Mashizha 2019; Mutandwa et al. 2019; Nyahunda and Tirivangasi 2019). The most daunting setbacks are the soaring

poverty levels, low adaptive capacity and unemployment levels in these rural communities and climate change impacts is exacerbating the situation (Nyahunda et al. 2019).

In the foregoing, a plethora of studies in the climate change discourse in Zimbabwe's rural communities, Chivi south and Umzingwane districts included, testifies that rural people are not passive victims to the vagary impacts of climate change but they are responding to it through a plethora of adaptation and mitigation strategies (Gukurume 2013; Dube and Phiri 2013; Ndebele-Murisa and Mubaya 2015; Bhatasara 2018; Nyahunda et al. 2019). These adaptation strategies are aimed at insulating their lives and livelihoods from climatic shocks. What should be highlighted is that, in the process of embarking on a cocktail of adaptation strategies, rural people are still confronted by a myriad of challenges serving as barriers to effective adaptation (Nyahunda and Tirivangasi 2019). In the ongoing, Chanza and Gundu-Jakarasi (2020) opine that Zimbabwe is showing an avalanche of gaps towards climate change adaptation and mitigation. This is because, evidence of climate change in Zimbabwe portrays a predominantly challenging situation. As a result, climate change adaptation efforts in rural communities remain on the onslaught because of lack of adaptive capacity among rural people. Also, the socioeconomic plagues bedeviling Zimbabwe connotes that efforts to enhance modest climate change management through effective adaptation and mitigation remain constrained. This is because there is no evidence of studies dedicated to unravel the efforts being made to address the barriers to climate change adaptation in the rural areas. From this background, this chapter is predetermined to delineate the barriers to climate change management in Zimbabwe's rural communities in a quest to influence the development and implementation of responsive climate change adaptation policy practices. Against this backdrop, the next sections provides a brief overview of barriers in the context of climate change. This is followed by the overview of climate change management where broad definitions of adaptation and mitigation are dissected. Subsequently, climate change management efforts made at national level in Zimbabwe are presented followed by the discussion about localized climate change management efforts. Furthermore, the chapter shall delve into the determinants of adaptive capacity before providing the barriers towards effective climate change management in Zimbabwe's rural communities. Lastly, the chapter shall capture measures to be undertaken to circumvent the identified barriers as Zimbabwe strives to foster adaptive capacity and resilience to climate change.

---

## **Barriers to Effective Climate Change Management in Zimbabwe's Rural Communities**

An array of definitions about barriers have been propounded in the climate change discourse. In the light of this, Biesbroek et al. (2011) define barriers as impediments amidst the implementation of climate change adaptation strategies. Barriers could be factors or conditions that are largely insurmountable which render adaptation to climate change ineffective (Kruse et al. 2013). Yaro et al. (2015) view barriers as



reasons why adaptive capacity is not attainable or being translated into action in the climate change discourse. Also, barriers can be institutional facet, normative or cognitive factors that restrict individuals or groups from implementing appropriate or sustainable forms of adaptation measures (Muzari et al. 2016). In the ongoing, Eisenack et al. (2014) regard barriers as obstacles that make adaptation to climate change less effective or less efficient. Earlier, Biesbroek et al. (2011) opined that barriers are different from limits as highlighted in some climate change literature. This is because barriers are mutable, avoidable, overcome, or reduced whereas limits are seen to be unsurpassable. In support, Yaro et al. (2015) denote that barriers can be overcome by individual or concerted collective effort, changed way of thinking, reprioritization of resources, institutional support, and political will. From the view point of Chanza et al. (2019), barriers are human or natural factors that impede adaptive efforts. As for Bhatasara (2018), barriers in the context of climate change adaptation are constraints faced during the adaptation processes. Despite a plethora of definitions and characteristics of barriers submitted by different scholars, in this study, the researchers paid homage to the definitions of barriers that point to conditions or factors rendering adaptation less effective or factors behind low adaptive capacity of rural people. In light of the above, several studies on climate change adaptation reveal that rural people are saddled by an avalanche of challenges serving as barriers to effective climate change management (Chanza et al. 2019; Nyahunda and Tirivangasi 2019). The understanding of barriers is an important escapade to gain ambient grounds to propose ways of dealing with them. Based on this, the barriers reported in this study were found to be restricting the process of adaptation and decreasing the adaptive capacity of rural farmers.

## Overview of Climate Change Management

In this section, climate change management refers to response mechanisms employed human systems to address climate change and its associated risks through adaptation and mitigation measures. In the light of this, the Intergovernmental Panel on Climate Change (IPCC 2014) defines climate change adaptation as response strategies employed by human or natural systems to reduce exposure to climate change risks and to minimize harm or exploit its beneficial opportunities. On the same note, adaptation entails changes and adjustments effected in response to perceived or actual negative stimuli's (climate change) which breeds opportunities for sustainable change and development (Chanza 2014). The United Nations Framework on Climate Change Convention (UNFCCC 2014) defines climate change mitigation as strategies employed by human systems to reduce greenhouse gasses and emissions that cause climate change. To shade more light, Muzari et al. (2016) posit that mitigation involves technological and behavioral adjustments which promote land conservation and preservation, managing deforestation and resorting to renewable energy sources aimed at enhancing greenhouse gas sinks.

From the above expositions, what should be highlighted is that mitigation and adaptation play complementary roles. This connotes that mitigation is poised to

stabilize the climatic system thereby minimizing pressure on adaptation (Chanza and Gundu-Jakarasi 2020). Earlier, Chanza (2014) argued that when mitigation fails, adaptation becomes a bone of contention. However, it is important to note that mitigation is more costly to implement for smallholder farmers because it requires technological advancements and modern infrastructural development which are still far from being a lived reality particularly in Zimbabwe. As such, several studies in Zimbabwe's rural communities have captured an avalanche of evidence that points to climate change adaptation in rural communities (Gukurume 2013; Ndebele-Murisa and Mubaya 2015; Nyahunda and Tirivangasi 2019). The implementation of adaptation strategies in the wake of climate change is an interplay of natural perception that the climate system has changed and there is need to adapt, influence of indigenous knowledge systems about the changes in the natural environment which informs possible management measures through the utilization of available resources and the presence policy practices that influence adaptation.

In the ongoing discussion, it is important to emphasize that a plethora of climate change impacts and a vicious vulnerability circle bedeviling most rural communities is making adaptation an inescapable discourse. Due to the fact that responding to the causes of climate change (mitigation) will take time, adaptation becomes a necessity to save people's lives and livelihoods. Most importantly, adaptation to climate change impacts is now a cardinal requirement to reduce its daunting risks and reap the benefits of adaptation (Nyahunda et al. 2019). Furthermore, there is a ubiquitous acknowledgement that without adaptation, climate change and its precarious impacts become detrimental on people's lives and livelihoods. Thus, if people fail to adapt to climate change impacts, they become vulnerable to social disruptions, ailments and deaths brought about by climate change. Based on this, Chanza (2014) provides a synopsis of types of adaptation in the climate change discourse as follows;

- (i) Anticipatory adaptation: This type of adaptation takes place before the eruption of climate change and its impacts are observed. In other cases, this type of adaptation is called proactive adaptation.
- (ii) Autonomous adaptation: This is also referred to as spontaneous adaptation common in most communities where climate change is at the epicenter of people's lives. As such, this type of adaptation is triggered by the observation of ecological changes in the natural or human systems which encumbers people's welfare.
- (iii) Planned adaptation: This type of adaptation is influenced by policy measures out of the acknowledgement that the climate system has changed or is about to change and strategic action is required to minimize its impacts.

To extrapolate from the above, earlier arguments denoting that adaptation and mitigation play complementary roles means proactive (anticipatory) adaptation may suppress the climate change phenomenon from occurring which is also the purpose of mitigation. Proactive adaptation is still a challenge in Zimbabwe's rural communities because it requires strategic planning, early forecasting determinations, suppression of anticipated hazards through technology. Importantly, successful climate

change management through adaptation is a product of adaptive capacity which refers to the ability of a social ecological system to organize itself and respond to climatic induced damages, learn from them and make use of the advantages present to moderate the risk (IPCC 2014). To this end, the ongoing discussion in this chapter shall navigate on efforts made by the Zimbabwean government to manage climate change impacts at national and local levels before delving into a brief discussion about the determinants of adaptive capacity.

---

## **Climate Change Management Efforts at National Level in Zimbabwe**

The Zimbabwean government has not been complacent in responding to climate change despite presenting challenges in the country's economic trajectory. Accordingly, the country recognizes the critical contribution of climate change variability in stalling its developmental aspirations (Chanza and Gundu-Jakarasi 2020). In response, the country came up with a gamut of strategies and policy measures signaling a broad-based commitment to tackle climate change and its impacts. Based on this, the Zimbabwean government developed the Zimbabwe Climate Change Response Strategy in 2014. The strategy provides guidelines on coordination and mainstreaming of climate change factors into the country's developmental trajectory to be implemented at local, district, provincial, and national levels (Dodman and Mitlin 2015). The development of the National Climate Change Response Strategy was the first step which subsequently led to the development of the country's National Adaptation Plans (NAPS), National Adaptation Programme of Actions (NAPAs), and Nationally Appropriate Mitigation Actions (NAMAS) as mandated by the Kyoto Protocol and the UNFCCC (Dodman and Mitlin 2015). Zimbabwe's NAPs are aimed at mainstreaming climate risks into national developmental planning, programs, and policies.

Furthermore, the strategy identified key sectors that are vulnerable to climate change such as energy, water, health, agriculture and food security, land usage, forestry, livestock production, industry and commerce and transport. Responsively, the strategy explicitly provides key actions to be undertaken to enhance either adaptation or mitigation in the identified sectors (Makaudze 2016). To add on, in 2016, Zimbabwe developed and promulgated its Climate Change Policy to be supported by the National Climate Change Response Strategy. In the light of this, Zimbabwe's climate change policy draws lessons from the international instruments and protocols which Zimbabwe is a signatory such as the UNFCCC, the Kyoto Protocol, and the Paris Agreement. These instruments provide emphasis on the importance of strategic measures to curtail climate change impacts through crafting, implementing, and regularly publish and update regional and national measures fostered to mitigate climate change effects complemented by facilitation of sustainable climate change adaptation (Zhakata et al. 2017). In the ongoing cluster of arguments, Murombo (2019) denotes that Zimbabwe's climate change policy provides a framework for addressing climate change-related impacts through the

development of national adaptation and mitigation efforts. Among other key principles encapsulated in the climate change policy include: the government's commitment to encourage the use of efficient irrigation technologies, promotion of climate tolerant crop varieties and provision of livestock insurance, creation of climate conscious societies that would scale up collective participation in climate change interventions including adaptation and mitigation and upscaling the provision of climate extension services to the farming rural communities especially those depending on climate sensitive resources.

Through the harmonization of the dictates of Zimbabwe's Climate Change Response Strategies and the National Climate Change Policy, the Zimbabwean government created Local Area Adaptations Plans (LAPs), District Adaptation Plans (DAPs) and Provincial Adaptation Plans (PAPs). These provide a database of weather conditions and events in every area, past and present climatic trends and their risks, the area's vulnerability, projections of future climatic scenarios and resources in the areas that can be used for effective planning that builds resilient communities to climate change impacts (Zhakata et al. 2017). Notwithstanding the daunting fact that Zimbabwe's gamut of climate policies and aspirations are devoid of implementation owing to lack of strategic coordination and financing plans, the country is committed to undertake a comprehensive analysis to understand the barriers to climate change adaptation in its policy frameworks. Once again, this stance is not yielding any positive outcomes because rural communities have been saddled by barriers in their efforts to adapt to climate change (Chanza et al. 2019).

---

## Climate Change Management Strategies at Local Levels

This section provides a catalogue of adaptation strategies employed by rural people in Chivi and Umzingwane districts and other rural communities in the wake of climate change and its related shocks in Zimbabwe. As articulated earlier that efforts to manage climate change through mitigation are not feasible in rural communities that are trapped by the doldrums of poverty, underdevelopment and deficiency of infrastructures that warrant mitigation, this study captured adaptation strategies at play among rural people because adaptation despite its insurmountable barriers is feasible even in poor marginalized communities. Despite being located in different provinces, Umzingwane and Chivi districts are susceptible to a myriad of climatic stressors which have compounded majority of households into abject poverty. The soils in these districts are prone to soil erosion making crop production unattainable. To worsen the situation, in Masvingo and Matebeleland South provinces where these districts are located, erratic rainfalls are predominant which are around 500–600 mm (Mudzonga 2016).

In Chivi south and Umzingwane districts, communal farming is a major source of livelihood but the vicissitudes of climate change are rendering rainfed agriculture a futile exercise (Chanza et al. 2019; Muzari et al. 2016; Phiri et al. 2014). Nevertheless, this study established that rural farmers are not passive victims to the vagary impacts of climate change but they are responding to it through a cocktail of

adaptation strategies either individually or collectively. Having said that, adaptation to climate change in Chivi and Umzingwane districts is in two-fold that is; independently through the realisation by the community members that they need to adjust their practices in response to the changes and to a limited extent through the influence of the government and nongovernmental organization measures.

In the foregoing, this study captured the adaptation strategies employed by smallholder farmers in both districts in comparison with other studies conducted in other rural communities of Zimbabwe in the wake of climate change induced shocks. This process was important to identify the gaps towards effective adaptation for rural people. In that regard, this study found that crop diversification was a common adaptation strategy to climate change impacts in Umzingwane and Chivi south districts. What emerged is that, smallholder farmers have come up with contingent responses through amalgamation of farming strategies and diversification of crop varieties. In the light of this, most smallholder farmers have resorted to drought tolerant crops that could withstand the long dry spells caused by climate change. The growing of small grain crops such as pearl, finger millet, sorghum and rapoko is on the rise in these two districts. Similar findings were reported by Chanza et al. (2019) in Silobela district that farmers diversified their cropping strategies in response to climate change impacts. To add on, intercropping and crop rotation are common farming practices complemented by changing of planting dates, zero tillage and mulching practices. Diversification of cropping systems is also complemented by the increase in the domestication of drought tolerant livestock such as goats, sheep, guinea fowls and indigenous chicken. A study conducted in Bikita district by Nyahunda and Tirivangasi (2019) revealed that some farmers are growing legumes such as cow peas and beans because they mature early. With the assistance from NGOs such as World Vision Zimbabwe and Action Faim, 45 boreholes and 11 shallow wells were drilled in Chivi south district to support gardening activities and address water stresses. On the same note, in Umzingwane district, the Matebeleland Enhanced Livelihoods Agriculture and Nutrition Adaptation (MELANA) program drilled four solar-powered boreholes to support gardening activities. In Zvimba district, Mashizha (2019) found that even without knowledge of climate change people have adapted at least one strategy and crop diversification was the common one. In Chimanimani district, Mutandwa et al. (2019) established that farmers have diversified their farming methods through varying crop planting dates. Conservation farming was also reported complemented by the use of contour ridges and mulching activities.

Results from a study conducted in Gwanda district by Ndlovu et al. (2020) reveal that pit planting is a key adaptation strategy and this is complemented by mulching activities to retain soil moisture. Conservation farming was also identified in Mutoko district by Bhatasara (2018). Also, in Mutoko, micro irrigation systems through the syphoning of water manually from the rivers was on the rise when water sources are not dry. In Chundu and Nyamakate resettlement areas, Kupika et al. (2019) established that rural farmers are cultivating in the wetlands and digging of wells along river beds to supplement agricultural activities. Rearing of small livestock such as goats, sheep and indigenous chicken was also reported in Zvimba, Hwedza,

Bikita, and Kariba districts (Mubaya and Mafongoya 2017; Zvamasiya et al. 2017; Nyahunda and Tirivangasi 2019).

The uncertainty of agriculture production has ignited most rural farmers to diversify their livelihood activities. In the light of this, livelihood diversification is a process by which rural households embark on diversification of a portfolio of activities and social support capabilities for survival and in order to improve their standard of living (Gukurume 2013). Majority of smallholder farmers are embarking on ex-post adaptation mechanisms from main activities such as agriculture which has been decorated by dwindling harvests and droughts emanating from climate change occurring in the communities. These activities are meant to improve their income streams and guarantee food security threatened by climate change. To that end, livelihood diversification activities that were captured include; petty trading of fruits, vegetables and firewood, menial jobs such as brick molding and thatching of houses (among men), gold panning (common in Umzingwane district), cross border trading, beer brewing and artisanal fishing. Kamwi et al. (2018) affirm to this exercise by denoting that diversification of livelihoods warrants resilience in the face of adverse trends or sudden shocks such as climate change. In Silobela district, Chanza et al. (2019) found gold mining, bee keeping, selling of mopane worms and brick molding as common livelihood strategies. Brick molding and selling of firewood were also identified by Nyahunda and Tirivangasi (2019) as common livelihood strategies among rural people in Bikita district. Arguably, these activities have a backlash on the environment which people should protect from land degradation and deforestation. In the Middle Zambezi Biosphere Reserve, Kupika et al. (2019) established that rural people are taking menial jobs in nearby commercial farms. To add on, in Zvimba district, Mashizha (2019) identified casual labor and artisanal mining among the livelihood diversification strategies. Soropa et al. (2019) established that in Tsholotsho and Chiredzi districts, the selling of mopane worms is very common as a supplementary economic activity to compensate the losses incurred from failed harvests.

Furthermore, migration emerged to be another adaptation strategy to climate change in Zimbabwe's rural areas commonly among men. The pervasive patriarchal dominance and social ascribed roles and care giving responsibilities of women limit them from migrating when climate change related disasters strike. This study found that most male figures in Chivi south and Umzingwane districts had either migrated to nearby cities or neighboring countries such as Botswana and South Africa in search for greener pastures. These migrants are remitting their incomes to support their families back home through securing of food, paying of school fees and medical bills and buying of essential farming inputs. Migration has been identified as a common adaptation strategy to the vagary impacts of climate change across Zimbabwe (Chanza et al. 2019; Soropa et al. 2015; Mugambiwa and Rukema 2019; Mubaya and Mafongoya 2017).

The reliance on Indigenous Knowledge Systems (IKS) emerged to be another cardinal adaptation strategy among rural people in Chivi south and Umzingwane districts. Chanza (2014) defines indigenous knowledge as a body of knowledge accumulative based on practice, belief and coordinated adaptive techniques passed

through generations on cultural transmission basis denoting how human beings create a relationship with the environment. Through the use of IKS, rural people in Chivi south and Umzingwane districts have developed meticulous systems of gathering, predicting, interpreting and making decisions related to weather. In the same wavelength, they are using this knowledge to devise modest agricultural practices, observation and forecasting of potential impacts of climate change thereby planning proactive adaptation measures, protection of crops, livestock and other assets against climate change induced disasters. On the same note, this is commonly done through a meticulous observation of animal behaviors and sounds, wind direction, astronomy correlation between movements of stars and haze circles around the moon to predict good and bad harvests. In Murehwa, Tsholotsho, and Chiredzi districts, Soropa et al. (2015) opine that rural farmers are using IKS to predict the quality of the season before the onset of the rains. In light of this, IKS indicators are observed early before the season commences. Similar findings about the usage of IKS as a determinant for climate change adaptation were reported by several scholars in studies conducted across Zimbabwe (Mubaya and Mafongoya 2017; Gukurume 2013; Nyahunda and Tirivangasi 2019; Chanza et al. 2019; Mashizha 2019).

What should be noted is that the use of trees and availability of certain wild fruits as a determinant of good and bad seasons was reported in Chivi and Umzingwane districts as in most parts of Zimbabwe. In the same line of argument, the trees, birds and wild fruits used to make seasonal forecasting differ from district to district. In Chivi and Umzingwane districts, IKS is relevant through reading the abundance of wild fruits and flowering of certain plants as a guarantee of the quantity of rain expected. In Zvimba, Bikita, Gwanda, Mutoko, and Murehwa districts, plenty of wild fruits guarantees a good season and a few wild fruits signals drought (Bhatasara 2018; Soropa et al. 2019; Mashizha 2019; Nyahunda and Tirivangasi 2019; Ndlovu et al. 2020). In Chiredzi, early flowering of trees and many mopane worms signals good harvests. Also, in Tsholotsho, heavy sound of animals such as lions in October guarantees a good season (Soropa et al. 2019).

At local levels, this study further found that people are harnessing social capital as an adaptation strategy to climate change. Gukurume (2013) defines social capital as a social web of networks created through interaction which strengthens trust and social norms. In light of this, norms, trustworthiness, and networks that tie people together through kinships, friendship and neighborhood defines social capital (Aldrich and Meyer 2015). Through harnessing of social capital, rural people in Chivi south and Umzingwane districts are making collective efforts to withstand the climate change aberrations by sharing scarce resources such as water and food. It further emerged that there are community savings clubs initiated to improve the income streams and generate funds to buy agricultural inputs, small livestock which are drought tolerant, construction of quality houses that can withstand floods and drilling of wells. In the same vein, rural people are embracing social capital through collective field (Nhimbe) work where they converge to work on certain tasks mainly planting, cultivation, and harvesting. Rural people are on record of utilizing social capital to share skills and problem-solving knowledge in

the wake of disasters. Further, Aldrich and Meyer (2015) argue that social capital fosters community engagement, cooperation and participation which are essential in addressing community challenges such as climate change. In corroboration, Musavengane and Simatele (2016) posit that social capital can be a vehicle through which the accumulation of different forms of capital can be achieved and contribute to environmental management.

Chanza et al. (2019) found social capital as a determinant for climate change adaptation in Silobela district through community lending and saving clubs called *mikando*. This was also identified by Nyahunda and Tirivangasi (2019) among rural people in Mazungunye communal lands and the activity is called *Fushai*. In the Nyaminyami area of Kariba rural district, Mubaya and Mafongoya (2017) found the harnessing of social capital in the wake of climate change aberrations manifesting through the Zunde raMambo project. Zunde is a Shona word that may mean a large gathering of people taking part in a common activity or may refer to plenty of grain stored for future use by people in a community (Chanza 2014). This is a traditional grain reserve where the harvest becomes useful in times of hunger. This practice is designated by the Chief (Mambo) (Nyahunda and Tirivangasi 2020). In the Muzarabani area, Chanza (2014) found the Zunde raMambo as the system that serves as a local social safety net for the poor and vulnerable members of the community from food insecurity caused by climate change. In Gutu district, Ndebele and Murisa- Mubaya (2015) found the Zunde raMambo as an important practice against climate change risks and the weakening of national social security schemes attributed to resource constraints and erratic food relief supply chains.

In continuation, in Chivi district as reported in Hwedza and Mutoko districts by Zvamasiya et al. (2017) and Bhatasara (2018), the predominance of social groups is also the hallmark for climate change adaptation. Similar findings were made in Chimanimani district by Mutandwa et al. (2019) that community members were creating social networks and mutual relationships for the purpose of sharing climate responsive strategies and sharing of information as well as best practices. In summing up this section, it is important to note that the presence of adaptation strategies documented in this study doesn't mean that rural people are effectively adapting to the impacts posed by climate change rather they are confronted by a myriad of conundrums serving as barriers to effective adaptation. The capture of adaptation strategies at play in these rural communities was essential to signpost the gaps in the process of adaptation. Having said that, the following section shall delve into determinants of adaptive capacity.

---

## **Determinants of the Ability to Adapt to Climate Change (Adaptive Capacity)**

This section shall navigate on indicators of adaptive capacity. This is important to create a barometer that can be used to assess whether rural people are effectively adapting to climate change or not. The presence of the determinants of adaptive capacity connotes that there is effective adaptation while the absence of all or some



of its determinants imply that there are barriers to effective adaptation to climate change. Accordingly, this study juxtaposed the circumstances in Chivi and Umzingwane districts against the indicators of adaptive capacity as contemplated in a plethora of climate change adaptation literature. In the light of this, Yaro et al. (2015) denote that adaptive capacity is determined by an array of factors which are neither mutually exclusive nor independent but as a result of a combination of these factors. Based on this, the determinants of adaptive capacity were examined following the previous assessments of adaptive capacity made at local levels by Hinkel (2011), Abdul-Razak and Kruse (2017), and Yaro et al. (2015). As such, the following are the determinants of adaptive capacity in the climate change discourse.

### **Economic Resources**

Farmers with a diverse source of income stand a better chance to adapt to the impacts of climate change than those without. Economic resources can be through a confluence of remittances and access to credit facilities that give the smallholder farmers the ability to be responsive in the wake of climate change and its related impacts. It is important to note that, economic resources can be gained through diversification of livelihood activities hinged on access to opportunities. Thus, farmers with economic security can be easily insulated from the precarious impacts of climate change. This is because they can afford to buy climate sensitive farming inputs including hybrid seeds, pesticides and stock feed for livestock. Economic security is the hallmark for food security even under circumstances where agricultural returns are low owing to climate change. On the same note, farmers with economic security have the ability to insure their crops and other assets in the wake of climate change induced disasters such as floods, hurricanes and veld fires.

### **Training and Awareness**

Training as an indicator for successful adaptation implies that farmers with vast farming experience and access to extension services that enhances training, knowledge and skills about climate change stand a higher chance of adapting to climate change impacts than those that lack farming experience and training. Experienced farmers have etiquette indigenous adaptation practices and they have the ability to identify and react to climatic fluctuations. In the ongoing, there is a positive correlation between literacy levels and ability to adapt to climate change. This speaks to farmers with high literacy levels having the ability to adapt than those with lower or without literacy levels. What should be underscored is that knowledge that warrants successful in the climate change terrain is a product of education either formal or informal. Hinkel (2011) posit that education, training and public awareness on climate change is essential for influencing the society to jointly participate in climate change management that is adaptation. In this regard, the

availability of knowledge influences decision making peculiar for adaptation. To add on, climate knowledge includes evidence-based beliefs and practices about the causes and effects of climate change. In support, Bowen et al. (2012) aver that availability of information allows every population to deduce that something has taken a paradigm shift hence there is need to adapt. This helps to foster an intrinsic assessment on the severity of the disturbance and devise amicable solutions respectively. Lastly, exposure to knowledge enables rural people to evaluate possible actions to be undertaken and pay attention to those that are useful in tandem with their circumstances.

## **Social Capital**

Social capital is one of the many resources available to individuals in every community despite presenting circumstances. This is a web of social networks created through interaction with other members of the community which serves as a hallmark of adaptation when people share resources, information and collective norms to build resilience against climate change. Adaptation to climate change rests on a social component as individuals interact with other network members to share resources, gain information, build new institutions and create collective norms, in order to provide resilience to climate change. As such, social capital serves as a public good in supporting whole communities through extreme events such as climate change (Dussaillant and Guzmán 2014). In the history of climate change strategies, social capital serves as an important vehicle used to acquire agricultural resources, shared problem-solving techniques, information dissemination, knowledge generation, sharing of experiences and solutions for disaster management. This connotes that people with social capital ties can easily adapt to climate change perturbations. Notably, social capital begets social protection.

## **Equity**

Communities with contingent equity practices have ambient environments for successful adaptation to the climate change impacts by all members. In as much as this is an unlikely situation in most rural communities in Africa, adaptation is also a product of equity where there is fairness and equality in sharing of climate change burdens and benefits, equal distribution to resources and opportunities including climate change information, early warning awareness regarding disasters across gender constructs. Issues of equity as an indicator for adaptive capacity means men and women are equally involved in the planning and implementation of climate change interventions at all levels. This also speaks to the inclusion of other vulnerable groups in societies that is the elderly and people with disabilities.

## Availability of Technology

The availability of technologies that enhances the farmers' knowledge about climate change crop varieties, soil moisture and fertility retention techniques is a panacea for climate change adaptation in communities where they are present unlike in those without. Relevant technologies in the climate change discourse are techno-science mechanisms aimed at assisting people in adjusting to changes for instance irrigation systems, drought resistant crops, use of remote sensing, local weather forecasting and early warning information systems.

## Availability of Infrastructures

For successful adaptation to take place, there is need for infrastructural and technological support systems (IPCC 2014). The availability of the same infrastructures plays a pivotal role in providing early climatic warning information and weather forecasting. Basically, they form part of relevant networks that are important aspects in curbing climate change impacts and foster the ability to respond to natural disasters associated with climate change which manifest through droughts, floods and hurricanes. Important infrastructures that can facilitate successful adaptation to climate change include; irrigation facilities, water catchments, boreholes, schools, quality roads, health care facilities and transport. Despite all these fundamentals (infrastructures) missing or being inadequate in rural communities, in cases where they are available, they foster successful adaptation in the wake of climate change.

## Availability of Institutions

The availability of institutions that support or enhance adaptation is the hallmark for adaptive capacity. Institutions play a cardinal role in the assessment of adaptive capacity and resilience building. These institutions include; public and private institutions that is the government and other stakeholders be it Nongovernmental Organizations or Community-Based Organizations. Institutional support that enhances adaptation to climate change can be through parallel practices between those institutions or through integration of their services. In the light of this, integrated institutional arrangements from local to national levels may provide essential support to the farmers to plan and implement contingent adaptation activities. In the same wavelength, strong institutions provide subsidies for agricultural inputs to rural farmers and disaster relief assistance in the wake of climatic induced perturbations. Hinkel (2011) strengthens the above by asserting that countries with modern social, private and public institutions have a high adaptive capacity level than those with no or low functional social institutions.

## **Barriers Towards Effective Climate Change Management in Zimbabwe's Rural Communities**

### **Poverty**

The conundrums of poverty are an albatross around the neck for majority of Zimbabweans in rural areas. Mhlanga and Ndlovu (2020) denotes that 73.3% of the Zimbabwean population are trapped under the manacles of poverty, majority of them in rural areas. As such, rural farmers in Chivi south and Umzingwane districts lack adequate resources to leap back from the climate change induced shocks. Smallholder farming in these communities is under siege because of the high dependence on natural erratic rainfalls. Resultantly, the endemic agricultural stagnation is leading to protracted food crisis and accelerated poverty levels. What it means is that, rural people in these districts are running short of adequate economic resources which anchors the ability to adapt to climate change impacts. Basically, poverty is a product of low literacy levels and high unemployment levels particularly in Umzingwane district where majority of the farmers haven't gone beyond primary education while others haven't obtained any formal education at all. Similar findings were made in Silobela district by Chanza et al. (2019) and in Gwanda district by Ndlovu et al. (2020) that the predominance of gold panning activities is leading to high school drop outs amongst the youth. As such, most people are school drop outs or haven't received any formal education.

In Zimbabwe, social protection systems are weak and rural farmers do not have financial reserves either credit or loan facilities due to the economic quagmires characterized by skyrocketing inflation projected to be at 750% by May 2020 (Dzobo et al. 2020). Consequently, peasant farmers in Chivi south and Umzingwane districts as in other rural communities of Zimbabwe are sinking deeper into poverty meaning they are facing a proliferation of obstacles to adapt to climate change. Earlier, Chanza et al. (2019) denoted that different educational levels and income have an impact on adaptation practices.

This study found that efforts by rural farmers in these districts to withstand the vagary impacts of climate change are impeded by the doldrums of poverty which they are entrenched into. In Chivi south district, most villages haven't benefited from the smart agricultural practices such as irrigations systems orchestrated by some NGOs in other parts of the district. As such, farmers in Danamombe and Mandamabwe communities lamented that agriculture is now a futile exercise without technoscience based farming mechanism. Similar findings were reported in Mulungwane and Mzinyathini communities in Umzingwane district that farmers cannot afford the relevant technologies essential for adaptation owing to high poverty levels. In the same vein, most farmers in both districts are stymied by financial setbacks to be able to purchase climate resistant crop varieties and other agricultural inputs. Majority of Zimbabwean are embroiled in confusion of the legitimacy of the local currency called the Real Time Gross Settlement (RTGs) against the United States Dollar which is used to peg prices of all commodities in Zimbabwe including agricultural inputs. The most poignant stance is that income

streams of most Zimbabweans and proceeds from the trading activities of rural people are in the valueless RTGs currency and the purchasing of farming inputs and other assets essential for adaptation remain a big mountain to climb thereby making adaptation to climate change a nightmare.

The most daunting fact is that the absence of social protection systems and safety nets from the government of Zimbabwe is making rural farmers to dispose their little assets in order to withstand the pressure of drought and other household emergencies. In Bikita district, Nyahunda and Tirivangasi (2019) found that rural people were selling their livestock at economically low prices to curb the conundrums of food insecurity. This makes the vicious circle of poverty infinite thereby inhibiting their efforts towards effective management to climate change. In the light of this, most rural people in Chivi south and Umzingwane districts are on record of selling of their livestock and other household assets at economically low prices to compensate losses from the agricultural activities. The economic tailspin bedeviling the country means there are also low remittances from local migrant workers to support their families. These dynamics validate the assertions made by the IPCC (2014) that most Southern African communities are trapped in a vicious circle of poverty which consequently make them vulnerable to climate change exacerbated by low adaptive capacity. Furthermore, poverty hampers rural people in Chivi south and Umzingwane districts from executing opportunities for climate change adaptation and they remain highly vulnerable to climate change and its impacts.

To extrapolate from the previous section which explored the determinants of adaptive capacity where economic security is one of them, it is important to note that most rural farmers fail to meet the standard measure of economic resources essential for climate change adaptation. Thus, poverty is a barrier towards effective climate change management in Zimbabwe's rural communities. Chanza et al. (2019) denotes that in Silobela district, rural people's dependence on climatic sensitive livelihoods is exacerbating their poverty levels. The manifestations of climate change through recurrent episodes of drought, perennial dry spells, thunderstorm and desiccation of water sources has a direct impact on rural people's livelihoods. Nyahunda and Tirivangasi (2019) allude that in Bikita district, rural people lack resources to procure climate viable resources such as hybrid seeds. In Makonde communal lands, Nyahunda et al. (2019) established that poverty is serving as a backlash towards rural people's adaptation efforts. In Mutoko district, Bhatasara (2018) found that rural farmers have limited agricultural capital due to the doldrums of poverty that they are entrenched in.

## **Inadequate Information about Climate Change and Adaptation**

In Chivi south and Umzingwane districts like in other rural communities in Zimbabwe and beyond, climate change information is still scant and in cases where it is available, climate information/knowledge is marred by mixed perceptions about its causes and consequences. This is attributed to inadequate information about the climate change discourse that is its causes, impacts to effective adaptation

and mitigation strategies. Notwithstanding the visibility of NGOs and other government departments charged with disseminating climate change information to rural farmers, the efforts remain parochial because most rural farmers are still grappling to understand the concept climate change and its dynamics. As such, lack of adequate information about climate change and adaptation makes most rural farmers in Chivi south and Umzingwane districts unaware of what they are dealing with (climate change) and how. In as much as a significant number of participants acknowledged to have heard about climate change, they appeared to lack critical information about the roles they have to play to address their plights through active participation in climate change adaptation processes.

What should be underscored is that the way climate change information is disseminated doesn't suit the literacy prowess of most rural farmers particularly in Umzingwane, Gwanda, and Tsholotsho districts (Soropa et al. 2015; Ndlovu et al. 2020). Failure to grasp the tenets of climate change is transcending to the lack of understanding about the need for adaptation, challenges in perceiving the changes or grasping the impacts of these changes in the climate. It is important to infer that the determinants of adaptive capacity encapsulated in the previous section serve as barriers to effective adaption when they are not sufficiently available. In that regard, inadequate awareness and information about climate change adaptation is serving as a barrier towards effective adaptation among smallholder farmers in Zimbabwe's rural communities. In Chundu and Nyamakate resettlement areas, Kupika et al. (2019) established that seasonal forecasting is weak to enable farmers to adjust their cropping patterns. Climate change knowledge is regarded as cardinal to influencing the other determinants of adaptive capacity and this is missing among small holder farmers in Zimbabwe's rural communities. To add on, inadequate information about adaptation is making people not to take normative positions in responding to climate change. In light of this, some of the strategies employed by rural people especially in Umzingwane, Tsholotsho and Silobela districts such as gold panning is detrimental to the environment that must be protected from degradation and erosion (Soropa et al. 2015; Chanza et al. 2019). On the same note, the livelihood activities that involve selling of firewood are accelerating the cutting down of trees in Chivi south and Bikita districts causing deforestation (Nyahunda and Tirivangasi 2019).

In continuation, the molding of bricks as part of livelihood diversification is also serving as a backlash on the environment stemming from the lack of adequate information about viable adaptation in the wake of climate change perturbations. Besides causing land degradation, these activities also cause mass deforestation because people use biomass fuels for curing the bricks (Chanza et al. 2019). A study conducted in Hwedza district by Zvamasiya et al. (2017) revealed that farmers with access to climate change information adopted sustainable adaptation strategies than their counterparts. Bowen et al. (2012) posit that a myriad of barriers can arise in the adaptation process from understanding the adaptation problem to devising appropriate adaptation measures that goes beyond managing the planned measures and the outcomes. Furthermore, availability of sufficient information enables people to respond to climate change impacts in a manner that serve their interests and ability

without compromising the environment for the benefit of the present and posterity. It is of paramount importance to infer that the availability of adequate and broad-based knowledge about climate change adaptation influences proper decision making thereby contributing to adaptive capacity. Thus, the deficiency of adequate information about adaptation is serving as a barrier towards effective climate change management in Zimbabwe's rural communities.

### **Lack of Adequate Institutions that Support Adaptation**

The success of adaption and mitigation in the climate change terrain is premised on the availability of institutions that support these processes. Basically, the availability of institutions that stimulate adaptation means rural farmers have buffer zones in the wake of climatic shocks. As mentioned earlier, institutions essential for adaptation might be the government through promulgation of policies that enhance adaptation, Non Governmental Organisations, Civic societies and Community Based Organisations among others. Institutions that support adaptation may provide subsidies, insurance and credit facilities to smallholder farmers. It should also be noted that ensuring the needs of marginalized, vulnerable, and remote communities are fully integrated in the national adaptation mechanisms is still a challenge for the government of Zimbabwe (Chanza and Gundu-Jakarasi 2020). Earlier, Muzari et al. (2016) denoted that ensuring that the needs of vulnerable populations are fully integrated in climate change measures is still a challenge for the Zimbabwean government. The country's Climate Change Policy envisages the commitment to set up climate change hubs in every province for easy gathering and collating of information. Furthermore, these hubs are poised to serve as climate information dissemination points aimed at reducing vulnerability through establishment of climate resilient infrastructures, efficient irrigation technology, crop and livestock insurance systems. Conversely, such commitments, are still being deliberated in the boardrooms without them translated to benefit s rural people (Zhakata et al. 2017).

Chanza and Gundu-Jakarasi (2020) further opine that governments are seen as key actors to intervene and circumvent existing barriers to adaptation by changing legislations or providing additional resources but this is not the case in Zimbabwe. To substantiate this, Nyahunda et al. (2019) allude that, Zimbabwe has an array of good climate policies that are not being converted into action because of misdirected priorities. As such, humanitarian organisations close much of the climate change management gaps created by the government. What is evident in some parts of Chivi south and Umzingwane districts are institutional support from NGOs such as World Vision Zimbabwe, Action Faim and MELANA in Umzingwane district. These NGOs are standing in the gap through the facilitation and provision of small grain crops and borehole drilling for small scale irrigation which has seen some gardening activities running in some communities. In Kariba rural district, Mubaya and Mafongoya (2017) found that that various nongovernmental institutions were supporting rural people's adaptation initiatives with inputs and forecast information. This cannot be said in some communities in Chiredzi district where Mamombe

(2017) discovered that most impoverished communities remain marginalized in terms of support services that enhance climate change adaptation and resilience. As such, most smallholder farmers lamented that there is no support in terms of access to timely weather forecasts, information about adaptation and credit facilities to motivate them to participate even in adaptation strategies and this is constraining their ability to adapt. Similar findings were made by Nyahunda and Tirivangasi (2019) in Bikita district that rural people lack adequate support systems that foster adaptive capacity against the vagary impacts of climate change. On the same note, in Chimanimani district, Mutandwa et al. (2019) discovered that institutional support services were very minimal despite the visibility of climate change impacts in these communities.

The footprints of the tropical cyclone Idai which caused wanton death and destructions in March 2019 bears testimony to the deficiencies of institutional support in Zimbabwe's rural communities. This is because, early warning systems should have been disseminated to the communities since the tropical cyclone struck Mozambique weeks earlier before ravaging the eastern areas of Zimbabwe. Similar findings were reported by Chanza (2014) in the Muzarabani area that has a recurrent experience with floods. The author bemoaned lack of broad-based institutional support and disaster management systems before the floods strike and in the aftermaths of the floods. Furthermore, this study found that the institutional roadmaps at policy levels are a top down approach that disregard the local initiatives on adaptation. Consequently, this is constraining the local adaptation efforts devised at local levels which most smallholder farmers can define in tandem with their abilities and circumstances. Additionally, the lack of potential interventions to sustain livelihoods disrupted by climate change at institutional level is serving as a barrier towards effective adaptation. Policy measures are not being converted to become tangible deliverables meaning the poor marginalized communities remain trapped under unpleasant circumstances without means to leap back.

## **Gender Inequalities**

In the history of climate change adaptation in countries with weak socioeconomic rights for women, gender defines who has the ability to adapt to the vagary impacts of climate change particularly between men and women. To shade more light, Mazuru (2019) posits that gender is an important variable in the relationship between climate change and its human impacts. On that note, men, women, children and the elderly have different roles, needs, interests and opportunities, therefore, they are affected by climate change differently. This study was conducted amongst people of Shona and Ndebele cultural descents where cultural prescriptions are predominant in sanctioning interactions, access to opportunities, developmental initiatives and decision making between men and women. As such, patriarchal dominance is still pervasive in these rural communities like in other rural communities of Zimbabwe (Nyahunda and Tirivangasi 2020). It emerged in this study that gender inequalities are acute between men and women where cultural gender roles tend to assign more



household responsibilities such as cooking, laundry, water and firewood collection on women. The primary caregiving responsibility of women is making them to be predominant in the agricultural sector and reliance on the climate volatile natural resources to provide for their families. This is making them more vulnerable to the calamities stemming from the climate risks than men.

In light of the above, in Chivi south and Umzingwane districts, gender inequality is manifesting through discrimination of women from decision making planning processes, access to climate change information and opportunities, ownership of essential resources such as land and property rights. This study found that women have limited involvement in community politics and in other instances they face discrimination from decision making at household level particularly those from male headed households. In Gwanda district, Ndlovu et al. (2020) found that gendered responsibilities caveat the social mobility of women where they remain confined to the households as men exercise freedoms in up taking several adaptation strategies such as migration. To add on, in Mutoko rural district, Mugambiwa (2018) avers that women face cultural restrictions on mobility when climate change induced risks strike because culture require them to be confined to their homes and look after the family. Furthermore, in Marondera district, Garutsa et al. (2018) established that there are pervasive stereotypes embedded against women where their contributions even on cropping systems and livestock rearing are considered invaluable.

To worsen the situation, the measures taken by women in response to climate change are creating extra work load on top of other responsibilities that they shoulder mostly on food security, cooking, primary caregiving, water and fuel collection (Nyahunda et al. 2019). Rural women are spend most of their time scouting for scarce resources such as water, fuel and food. This is inhibiting them from being actively involved in decision making processes regarding climate change or embarking on income generating activities that warrants adaptation. In the Domboshava rural areas, Tanyanyiwa and Mufunda (2020) exposit that the social inequalities are making women vulnerable to drought because they shoulder the primary responsibility of securing and providing food amidst failed agricultural production owing to climate change. To extrapolate from the determinants of adaptive capacity premised on equity, evidence from this study bears testimony that there is no fairness and equality in sharing the burdens of climate change, distribution of resources essential for adaptation between men and women. The burden of walking farthest distances in search of water and firewood is detrimental to their health and this has a boomerang effect on their ability to adapt to climate change like men. Women continue to be absent from climate change decision making processes where adaptation measures are devised. The pervasiveness of patriarchal dominance in Zimbabwe's rural communities serve as a barrier for adaptation to climate change impacts for women despite them being heavily impacted.

### **Inadequate Extension Services**

The commitment by the Zimbabwean government to promote training and extension support that would allow climate change management practices as encapsulated in

its climate change policy is not being converted into tangible deliverables in rural areas. In Zimbabwe, the Agricultural, Technical and Extension services (AGRITEX) department is responsible for the agricultural advisory role, provision of crop and livestock management and food and input distribution from the Grain Marketing Board (GMB). Some extension services are shouldered by the Communal Area Management Programme for Indigenous Resources (CAMPFIRE). What emerged in this study is that most smallholder farmers in Chivi south and Umzingwane districts are running short of the training and awareness that influence adaptive capacity (Hinkel 2011). In several communities which this study investigated, it emerged that extension services are scant and in cases where they are available, they are parochial to an extent that some farmers have not benefited from the extension services at all.

Inadequate access to extension services is serving as a barrier towards climate change adaptation in these districts. Similar findings were reported by Mugambiwa (2018) in Mutoko rural district that inadequate access to extension services has a negative effect on the farmers ability to adapt to climate change. This is because access to agricultural extension services contributes to the smallholder farmers' knowledge of climate change, its impacts and the need for adaptation (Zvamasiya et al. 2017). In the light of this, the inadequacy of information about climate change adaptation which serve as another barrier in Zimbabwe's rural communities stems from the lack of adequate and broad-based extension services that enhance training and awareness which resultantly informs adaptation. In Bikita district, Nyahunda and Tirivangasi (2019) established that farmers bemoaned the lack of commitment by extension officers unlike before where they used to conduct field visits and provide improved climatic information as well as technical assistance. Mavhura (2020) further argues that farmers with access to extension services are likely to develop a positive attitude and are willing to take contingent actions to reduce its impacts. In Chivi south and Umzingwane districts, small holder farmers lamented that extension officers appear to have parochial knowledge about climate change. This can be attributed to lack of adequate training about climate change (Nyahunda et al. 2019). Nevertheless, it should be highlighted that, extension services have a positive influence on behavioral patterns that can foster adaptation measures. At this juncture, it is important to infer that the more the Zimbabwean government clings to its climate policies without implementation, the more the daunting circumstances of rural farmers remain unattended.

## **Outbreak of Health Emergencies**

As the researchers traversed in gathering data to find answers to the objective of this study, it emerged that the outbreak of pandemics such as malaria and Corona Virus Disease (COVID-19) is stalling the adaptation efforts of rural people. Matebeleland south province where Umzingwane district is located has been reeling with the surge of malaria disease. Also, in the Chiredzi district in Masvingo province, Zengenene et al. (2020) allude that malaria prevalence is always recurrent. As such, rural farmers' meagre resources have been channeled towards meeting health care costs among

other exigencies (Tapera 2019). The outbreak of the COVID-19 as a global pandemic exacerbated the situation in Zimbabwe like in many countries around the globe. Response mechanisms adopted by the Zimbabwean government in tandem with the guidelines provided by the World Health Organization (WHO) resulted in the pronouncement of the nationwide lockdown on the 26th of March 2020 to curb the transmission of the virus (Mhlanga and Ndhlovu 2020). The lockdown measures prescribed citizens to be confined to their homes only to leave to procure basic commodities including medications or as essential workers. On the same note, businesses, schools, and borders were closed (Dzobo et al. 2020). The most daunting factor about the pronouncement of the nationwide lockdown is that, it disrupted most livelihoods particularly those in the informal sector where most rural people are involved as part of their livelihood diversification strategies to withstand the impact of climate change.

To add on, the most poignant factor is that the lockdown measures were decreed without safety nets in place for the poor neither the availability of disaster relief packages to the already vulnerable populations by the government. As such, the outbreak of the COVID-19 pandemic serves as a double blow for rural farmers that have been reeling with climate change impacts for some time. What should be underscored is that adaptation efforts employed by most rural people to withstand the impacts of climate change through a cocktail of strategies were shattered, disrupted and disfigured by the outbreak of the COVID-19 pandemic. The eruption of the COVID-19 pandemic juxtaposed to the resurgence of malaria disease is disruptive and could potentially lead to food security and stunted livelihoods in most rural communities.

This has a boomerang effect on the ability of rural people to adapt to the impacts posed by climate change such as drought. It is also important to infer that its only when people are healthy, with resources and with the liberty to embark on their livelihood activities that they can adapt to risks dovetailed by climate change. This is not the situation in the wake of the COVID-19 pandemic where gatherings that are the hallmark of social capital are prohibited and migration which is a common adaptation strategy is not feasible amidst the lockdown restrictions. Again, poverty levels among rural farmers are being widened under the confluence of climate change impacts and COVID-19 pandemic where most farmers are compelled to dispose their meagre resources to withstand the pressure of hunger and other losses. Lastly, the outbreak of health emergencies such as the COVID-19 pandemic stands to reverse the gains of adaptation made by rural people. To worsen the situation, the government is now focusing on devising contingent measures to mitigate the impacts of the disease and associated risks and climate change risks are no longer a priority despite them being visible in rural communities.

---

## Conclusion

This book chapter provided a synopsis of barriers towards effective climate change management in Zimbabwe's rural communities to guide policy developments and interventions dedicated to ameliorate the identified barriers and others that were not

captured in this study. As contemplated in the themes of this chapter, barriers can be circumvented or subjugated through the development and implementation of broad-based policy regimes that addresses the plights of the disadvantaged farming communities. To extrapolate from this, rural people can only triumph over the barriers to effective climate change adaptation when they are rescued from the jaws of poverty. This is because most challenges that inhibit adaptive capacity for rural people are hinged on poverty therefore other challenges evolve from the conundrums of poverty. As such, Zimbabwe still needs strong institutions that support climate change adaptation and mitigation. The presence of these institutions should be complemented by the recognition of the ability to adapt to climate change for citizens as the responsibility of the government and its subsidiary organs. This initiative should not remain in the board rooms or demonstrated on paper but it must be translated into practical interventions that addresses the felt needs of rural farmers. On the same note, there is need to improve the country's disaster preparedness planning, rescue and recovery systems where rural communities are beneficiaries of disaster proof mechanisms. Efforts to foster effective adaptation to climate change should mainstream the best practices of rural people hinged on indigenous knowledge and social capital. This is because these practices can be easily defined and accessed by every rural household regardless of socioeconomic status. Lastly, gender equality is essential to enhance adaptive capacity especially for women that are highly encumbered by climate change impacts than men. Cultural and traditional patterns that insubordinate women and exclude them from decision making processes need to be extinguished in Zimbabwe's rural communities for women to be able to adapt and remain resilient in the wake of climate change impacts.

---

## References

- Abdul-Razak M, Kruse S (2017) The adaptive capacity of smallholder farmers to climate change in the Northern Region of Ghana. *Clim Risk Manag* 17:104–122
- Aldrich DP, Meyer MA (2015) Social capital and community resilience. *Am Behav Sci* 59(2): 254–269
- Bhatasara S (2018) Understanding adaptation to climate variability in smallholder farming systems in eastern Zimbabwe: a sociological perspective. *Rev Agric Food Environ Stud* 99(2):149–166
- Biesbroek R, Klostermann J, Termeer C, Kabat P (2011) Barriers to climate change adaptation in the Netherlands. *Climate Law* 2(2):181–199
- Bowen A, Cochrane S, Fankhauser S (2012) Climate change, adaptation and economic growth. *Clim Chang* 113(2):95–106
- Chanza N (2014) Indigenous knowledge and climate change: insights from Muzarabani. Zimbabwe by Nelson Chanza Doctor of Philosophy in Faculty of Science
- Chanza N, Gundu-Jakarasi V (2020) Deciphering the climate change conundrum in Zimbabwe: an exposition. In: *Global warming and climate change*. <https://www.IntechOpen.org>
- Chanza N, Chigona A, Nyahuye A, Mataera-Chanza L, Mundoga T, Nondo N (2019) Diagnosing barriers to climate change adaptation at community level: reflections from Silobela, Zimbabwe. *GeoJournal* 84(3):771–783
- Dodman D, Mitlin D (2015) The national and local politics of climate change adaptation in Zimbabwe. *Clim Dev* 7(3):223–234
- Dube K, Nhamo G (2019) Climate change and the aviation sector: a focus on the Victoria Falls tourism route. *Environ Dev* 29:5–15

- Dube T, Phiri K (2013) Rural livelihoods under stress: the impact of climate change on livelihoods in South Western Zimbabwe. *Am Int J Contemp Res* 3(5):11–25
- Dube N, Moyo F, Sithole M, Ncube G, Nkala P, Tshuma N, Maphosa M, Mabheba C (2016) Institutional exclusion and the tragedy of the commons: artisanal mining in Matabeleland South Province, Zimbabwe. *Ext Ind Soc* 3(4):1084–1094
- Dussaillant F, Guzmán E (2014) Trust via disasters: the case of Chile's 2010 earthquake. *Disasters* 38(4):808–832
- Dzobo M, Chitungo I, Dzinamarira T (2020) COVID-19: a perspective for lifting lockdown in Zimbabwe. *Pan Afr Med J* 35(Suppl 2):1
- Eisenack K, Moser SC, Hoffmann E, Klein RJ, Oberlack C, Pechan A, Rotter M, Termeer CJ (2014) Explaining and overcoming barriers to climate change adaptation. *Nat Clim Chang* 4(10):867–872
- Garutsa TC, Mubaya CP, Zhou L (2018) Gendered differentials in climate change adaptation amongst the Shona ethnic group in Marondera Rural District, Zimbabwe: a social inclusions lens. *AAS Open Res* 1(14):14
- Gukurume S (2013) Climate change, variability and sustainable agriculture in Zimbabwe's rural communities. *Russ J Agric Socio-Econ Sci* 14(2):89
- Hinkel J (2011) "Indicators of vulnerability and adaptive capacity": towards a clarification of the science–policy interface. *Glob Environ Chang* 21(1):198–208
- Intergovernmental Panel on Climate Change (IPCC) (2014) Fifth assessment report. Impacts, adaptation and vulnerability. Cambridge University Press, Cambridge, UK/New York. Introduction. *Int J Soc Welf* 21(3):230–238
- Jiri O, Mafongoya PL, Chivenge P (2017) Building climate change resilience through adaptation in smallholder farming systems in semi-arid Zimbabwe. *Int J Clim Change Strat Manag* 9:151
- Kamwi JM, Chirwa PWC, Graz FP, Manda SOM, Mosimane AW, Kätsch C (2018) Livelihood activities and skills in rural areas of the Zambezi Region, Namibia: implications for policy and poverty reduction. *Afr J Food Agric Nutr Dev* 18(1):13074
- Kruse J, Simon J, Rennenberg H (2013) Soil respiration and soil organic matter decomposition in response to climate change. In: *Developments in environmental science*, vol 13. Elsevier, Amsterdam, pp 131–149
- Kupika OL, Gandiwa E, Nhamo G, Kativu S (2019) Local ecological knowledge on climate change and ecosystem-based adaptation strategies promote resilience in the middle Zambezi biosphere reserve, Zimbabwe. *Scientifica* 2019:1
- Makaudze EM (2016) Assessing the economic value of El Niño-based seasonal climate forecasts for smallholder farmers in Zimbabwe. In: *Climate change and multi-dimensional sustainability in African agriculture*. Springer, Cham, pp 591–612
- Mamombe V (2017) The impact of climate change on the rainfall patterns over Chiredzi district, Zimbabwe. *J Public Adm Dev Altern* 2(1–1):109–125
- Mashizha TM (2019) Adapting to climate change: reflections of peasant farmers in Mashonaland West Province of Zimbabwe. *Jamba: J Disaster Risk Stud* 11(1):1–8
- Mavhura E (2020) Learning from the tropical cyclones that ravaged Zimbabwe: policy implications for effective disaster preparedness. *Nat Hazards* 104(3):2261–2275
- Mazuru N (2019) Chapter nine climate change in Zimbabwe: challenges and prospects for rural women in Bikita District. In: *Necroclimatism in a spectral world (dis) order: rain petitioning, climate and weather engineering in 21st century Africa*. Langaa RPCIG, Mankon, p 255
- Mhlanga D, Ndhlovu E (2020) Socio-economic implications of the COVID-19 pandemic on smallholder livelihoods in Zimbabwe. Accessed at <https://www.preprints.org>
- Mubaya CP, Mafongoya P (2017) Local-level climate change adaptation decision-making and livelihoods in semi-arid areas in Zimbabwe. *Environ Dev Sustain* 19(6):2377–2403
- Mudzonga E (2012, August) Farmers' adaptation to climate change in Chivi district of Zimbabwe. In: *TRAPCA trade policy research forum*, Arusha, Tanzania, pp 7–8
- Mudzonga E (2016) The social protection policy responses in the primary and secondary education sector during the crisis period. *Economic management in a hyperinflationary environment: the political economy of Zimbabwe*, p 403:1980–2008

- Mugambiwa SS (2018) Adaptation measures to sustain indigenous practices and the use of indigenous knowledge systems to adapt to climate change in Mutoko rural district of Zimbabwe. *Jamba: J Disaster Risk Stud* 10(1):1–9
- Mugambiwa SS, Rukema JR (2019) Rethinking indigenous climate governance through climate change and variability discourse by a Zimbabwean rural community. *Int J Clim Change Strat Manag* 11:730
- Muroombo T (2019) Climate change in Zimbabwe: towards a low carbon energy industry. Forthcoming in climate change law in Zimbabwe: concepts and insights (Konrad Adenauer Foundation)
- Musavengane R, Simatele DM (2016) Community-based natural resource management: the role of social capital in collaborative environmental management of tribal resources in KwaZulu-Natal, South Africa. *Dev South Afr* 33(6):806–821
- Mutandwa E, Hanyani-Mlambo B, Manzvera J (2019) Exploring the link between climate change perceptions and adaptation strategies among smallholder farmers in Chimanimani district of Zimbabwe. *Int J Soc Econ* 4(4):6–9
- Muzari W, Nyamushamba GB, Soropa G (2016) Climate change adaptation in Zimbabwe's agricultural sector. *Int J Sci Res* 5(1):1762–1768
- Ndebele-Murisa M, Mubaya C (2015) Climate change: impact on agriculture, livelihood options and adaptation strategies for smallholder farmers in Zimbabwe. In: *Beyond the crises: Zimbabwe's prospects for transformation*. Weaver Press, Avondale, pp 155–198
- Ndlovu S, Mathe B, Phiri K, Nyathi D (2020) Factoring water harvesting into climate change adaptation: endogenous responses by smallholder farmers in Gwanda district, Zimbabwe. *Cogent Soc Sci* 6(1):1784652
- Nyahunda L, Tirivangasi HM (2019) Challenges faced by rural people in mitigating the effects of climate change in the Mazungunye communal lands, Zimbabwe. *Jamba: J Disaster Risk Stud* 11(1):1–9
- Nyahunda L, Tirivangasi HM (2020) Effects of climate change on rural women in Makhado municipality, Limpopo Province, South Africa. *Gender Behav* 16(4):12013–12020
- Nyahunda L, Matlakala FK, Makhubele JC (2019) Role of social workers in mitigating the effects of climate change in Makonde communal lands, Zimbabwe. *e-Bangi* 16(9):1–8
- Phiri K, Ndlovu S, Chiname (2014) Climate change impacts on rural based women: Emerging evidence on coping and adaptation strategies in tsholotsho, Zimbabwe. *Mediterr J Soc Sci* 5(23):1–9
- Soropa G, Gwatibaya S, Musiyiwa K, Rusere F, Mavima GA, Kasasa P (2015) Indigenous knowledge system weather forecasts as a climate change adaptation strategy in smallholder farming systems of Zimbabwe: case study of Murehwa, Tsholotsho and Chiredzi districts. *Afr J Agric Res* 10(10):1067–1075
- Soropa G, Nyamangara J and Nyakatawa EZ (2019) Nutrient status of sandy soils in smallholder areas of Zimbabwe and the need to develop site-specific fertiliser recommendations for sustainable crop intensification. *S Afr J Plant Soi* 36(2):149–151
- Tanyanyiwa VI, Mufunda E (2020) Sociocultural impact of climate change on women and the girl child in Domboshawa, Zimbabwe. *Clim Action* 5(2):827–837
- Tapera O (2019) Determinants of long-lasting insecticidal net ownership and utilization in malaria transmission regions: evidence from Zimbabwe demographic and health surveys. *Malar J* 18(1):278
- UNFCCC (2014) Report of the conference of the parties on its nineteenth session, held in Warsaw from 11 to 23 November 2013, decision 2/CP.19, Warsaw. Retrieved from <https://www.unfccc.int/resources/docs/>. Accessed 10 Oct 2019
- Yaro JA, Teye J, Bawakyillenuo S (2015) Local institutions and adaptive capacity to climate change/variability in the northern savannah of Ghana. *Clim Dev* 7(3):235–245
- Zengenene MP, Soko W, Brooke BD, Koekemoer LL, Govere J, Mazarire TT, Mberikunashu J, Munhenga G (2020) Anopheles species composition and breeding habitat characterisation in Chiredzi District, Zimbabwe. *Afr Entomol* 28(1):84–94

- Zhakata W, Jakarasi VN, Moyo EN (2017) Zimbabwe's actions towards climate resilience and low carbon development. *Int J Green Growth Dev* 101:13
- Zvamasiya B, Nyikahadzo K, Mukamuri BB (2017) Factors influencing smallholder farmers' behavioural intention towards adaptation to climate change in transitional climatic zones: a case study of Hwedza District in Zimbabwe. *J Environ Manag* 198:233–239

**Open Access** This chapter is licensed under the terms of the Creative Commons Attribution 4.0 International License (<http://creativecommons.org/licenses/by/4.0/>), which permits use, sharing, adaptation, distribution and reproduction in any medium or format, as long as you give appropriate credit to the original author(s) and the source, provide a link to the Creative Commons license and indicate if changes were made.

The images or other third party material in this chapter are included in the chapter's Creative Commons license, unless indicated otherwise in a credit line to the material. If material is not included in the chapter's Creative Commons license and your intended use is not permitted by statutory regulation or exceeds the permitted use, you will need to obtain permission directly from the copyright holder.





# *Dichrostachys cinerea* Growth Rings as Natural Archives for Climatic Variation in Namibia

# 117

Benjamin Mapani, Rosemary Shikangalah, Isaac Mapaure, and Aansbert Musimba

## Contents

Introduction .....	2434
Evidence for Climatic Variation from Dendrochronological Studies .....	2435
Samples and Data Processing .....	2436
Precipitation as Reflected in Tree Rings .....	2437
Growth Ring Responses to Climatic Variation .....	2439
Lessons Learnt from Arid and Semi-arid Savannas .....	2440
Conclusions .....	2443
References .....	2443

## Abstract

Global Circulation Models (GCMs) are used to forecast climate change in Southern Africa, and the evidence shows that the region is going to warm up by up to 2° by the year 2050. Namibia is one of the driest countries in Southern Africa and is at a high risk of becoming much drier than current situation by 57%.

This chapter was previously published non-open access with exclusive rights reserved by the Publisher. It has been changed retrospectively to open access under a CC BY 4.0 license and the copyright holder is “The Author(s)”. For further details, please see the license information at the end of the chapter.

B. Mapani (✉)

Faculty of Engineering, Department of Mining and Process Engineering, Namibia University of Science and Technology, Windhoek, Namibia

R. Shikangalah

Faculty of Humanities and Social Sciences, Department of Geography, History and Environmental Studies, University of Namibia, Windhoek, Namibia

e-mail: [rshikangalah@unam.na](mailto:rshikangalah@unam.na)

I. Mapaure · A. Musimba

Faculty of Science, Department of Biological Sciences, University of Namibia, Windhoek, Namibia

e-mail: [imapaure@unam.na](mailto:imapaure@unam.na)

© The Author(s) 2021

2433

W. Leal Filho et al. (eds.), *African Handbook of Climate Change Adaptation*,  
[https://doi.org/10.1007/978-3-030-45106-6\\_257](https://doi.org/10.1007/978-3-030-45106-6_257)



Very few studies have been carried out in Southern Africa to show actual impacts of climate change. Practical applicability of GCMs at a local spatial scale remains limited due to the coarse nature of the models. Hence, improvement of the GCMs must begin with better understanding of the local microclimates and how they respond to regional circulation patterns. In many regions of Southern Africa, the lack of potential tools to access old climatic records precludes the estimation of climate trends beyond 100 years. In spite of these impediments, there are areas with excellent tree species such as *Dichrostachys cinerea* that are able to be used as climatic archives for specific time periods. In this chapter, the study shows that the combination of tree ring chronologies and precipitation records is a powerful methodology in climate modeling in the southern hemisphere and reveals nuances that show climate change. The evaluation of data from tree rings coupled with precipitation trends reveals signals that show that climate has indeed been changing over the past ten decades and will have a negative impact on livelihoods. These data can now be used in predictive models that can be used to project future scenarios and assist policy makers and planners to see how climate will evolve in the next 50–60 years.

---

## Introduction

Current scientific, observational, and anecdotal data show that climate change is now a well-observed phenomenon in most parts of the world (IPCC 2007, 2015; Shikangalah and Mapani 2019). Traditional livelihoods of subsistence farming, food security, water security, and cultural organizational patterns are likely to be, and some are already impacted by effects of Climate change. Thus, climate change will be a major problem in the near future, impacting water resources, agricultural and food systems in Southern Africa, particularly Namibia (Adhikari et al. 2015). In Namibia, there is an increasing trend observed in flooding, droughts, and evapotranspiration (Zeidler et al. 2010). The shortening of the crop growing season, rising average summer and winter temperatures, is among some of the evidence of climate change impacts in Namibia (Mapaure 2016). Temperature in Namibia has been increasing at three times the global mean, and the increase in temperature prediction for 2100 for Namibia ranges from 2 °C to 6 °C, particularly in the central regions (Reid et al. 2007).

These impacts will with time increasingly limit water supply, development activities, and consequently will affect all cross-sections of society (Ohlsson and Turton 1999; Showers 2002; Gumbo 2003; Wang et al. 2009). A number of authors have predicted that a quarter of the world's population will experience severe water scarcity within the first quarter of the next century and approximately a billion people in arid regions will face absolute water scarcity by 2025 (Seckler et al. 1999; Ruth et al. 2007). Water demand in urban areas is constantly on the upswing in Africa, Namibia, included (Mapani 2005; Shikangalah and Mapani 2019). The water demand is anticipated to rise by 50% between 2010 and 2030 (Lafforgue 2016).

Trees are excellent archives of environmental site conditions that affect their biological processes (Breitenmoser et al. 2014) and this information is reflected in their growth ring histories. Growth rings provide information about the history of the area in which the trees are resident, including other information such as tree age, fire events, droughts, attacks by pests, logging, and severe storms (Xing et al. 2012; Feliksik and Wilczyński 2009). Growth rings in trees are influenced by climate conditions and they show distinct episodes of moist and dry periods for over time (Novak et al. 2013; Palmer et al. 2018; Shikangalah et al. 2020). Dendrochronology can be used to reconstruct and draw conclusions about rainfall patterns over regional, hemispheric, or even global scales (Zhang 2015; NASA 2008). Tree growth rings are a valuable proxy for climate change studies on both local and regional scales (Nock et al. 2016; Novak et al. 2013; Steenkamp et al. 2008). Data from growth rings records is valuable for providing information that may not be available in areas where climate records never existed in the past. Hence, they aid the understanding of ecosystem dynamics and to predict changes in the ecological surroundings. This information is especially important in arid and semi-arid environments such as Namibia, where sound land management is crucial due to the climate-related vulnerability of such environments and the frequent lack of observational data. This holds particularly true for Namibia as the country is the most arid in Southern Africa and second only in aridity to the Sahara Desert in North Africa (Food and Agriculture Organization (FAO) 2005; Turpie et al. 2010). More than 90% of Namibia's landmass is classified as semi-arid, arid, or hyper-arid, and the country is characterized by sporadic rainfall and high evaporation rates (Mendelsohn et al. 2002; Shanyengana et al. 2004; Barnard 2012). This chapter is aimed at assessing the responsiveness of *D. cinerea* to different climatic environments and thus be used as a proxy for climate change.

---

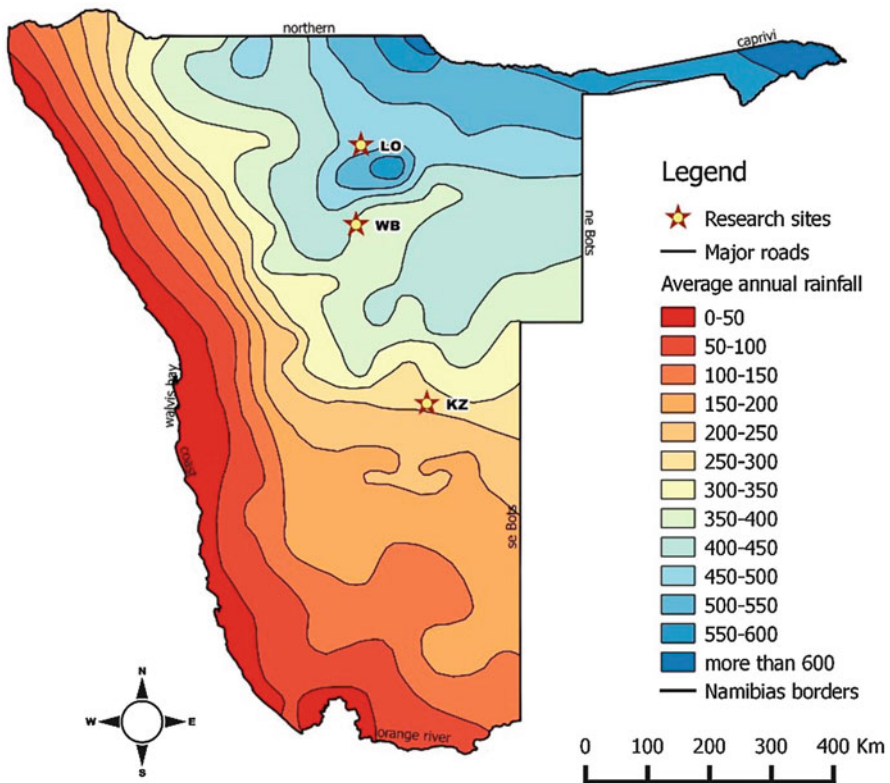
## Evidence for Climatic Variation from Dendrochronological Studies

In this study, we selected sites that had a degree of variation in both precipitation and temperature. This climatic gradient revealed how the species responded to different amounts of rainfall and temperatures. The study sites are located at Lake Otjikoto (19° 11' 41" S; 17° 32' 59"E); Farm Onyoka located on the Waterberg Plateau Park (20° 25' 0" S; 17° 13' 0" E), and Farm Kuzikus (23° 20' 0" S; 18° 21' 59"E) located south of Windhoek (Fig. 1). The annual precipitation for the study sites is 550 mm to 600 mm for Lake Otjikoto, 450–500 mm for Onyoka, and less than 300 mm for Kuzikus. These sites also vary in temperature as follows: an average annual temperature of 25 °C for Lake Otjikoto, 30 °C for Waterberg Plateau Park, and 31 °C for Kuzikus (Mendelsohn et al. 2002). Lake Otjikoto has better soils of loamy to clay with a good water holding capacity as opposed to the deep sandy Kalahari soils (Křibek et al. 2018; Mendelsohn et al. 2002; Rodgers et al. 2017).

## Samples and Data Processing

The precipitation data for 1970–2014 were obtained from Namibian official Meteorological Service in Windhoek. The growth rings of *Dichrostachys cinerea* were used, a native species to Namibia which is a fast-growing species that has become an undesirable encroacher and is particularly a problem in areas where there has been overgrazing (Orwa et al. 2009; Chepape et al. 2011; O'Connor et al. 2014). The population of *D. cinerea* decreases significantly from Lake Otjikoto site where the trees are abundant, to Kuzikus where the trees are very few (Fig. 1).

Wood samples of *Dichrostachys cinerea* were collected from randomly selected trees from three sites namely Lake Otjikoto, Waterberg, and Kuzikus (Fig. 1), with a total of 32 samples of *D. cinerea*. For each tree, one sample disc was taken at a height of about 1.0 m and air dried. The rings were identified using a combination of techniques for correction and validation of ring growth, that is, binocular microscope; WinDENDRO software, which automatically counts and dates each marginal parenchyma; and COFECHA program (Holmes 1983), which is commonly used in dendrochronology to ensure quality and measurement accuracy in growth ring segments



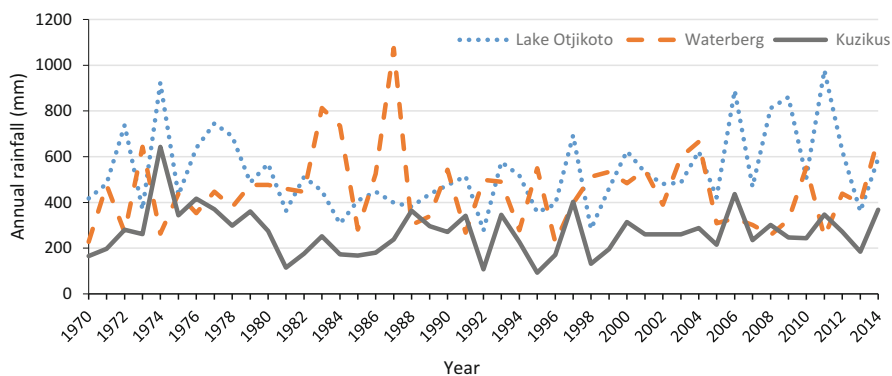
**Fig. 1** The three study sites Lake Otjikoto (LO), Waterberg (WB), and Kuzikus (KZ) are shown along the rainfall gradient in Namibia

(Grissino-Mayer 2001). To make sure that all the rings were correctly detected and dated by WinDENDRO software, at least four different paths radiating from the pith were created and analyzed (Grudd 2006; Heinrich et al. 2009; Shikangalah et al. 2020).

To explore the influence of temporal climatic variability on growth rings, the use of response and correlation functions from tree-ring chronologies and monthly climatic data was employed after the methods of Zang and Biondi (2013). Using the *dplr* package (Bunn 2008) of R 3.4.4 (R Core Team 2018), the *dcc* function in TreeClim Package in R was used. The *dcc* function builds upon and extends the functionality of program DENDROCLIM2002 (Biondi and Waikul 2004; Zang and Biondi 2013, 2015). A total of 32 samples were subject to spline detrending (50% frequency) and then averaged to a chronology using Tukey's biweight robust mean. The timeframe used is only for the wet period (November of previous year–April of current year) is used between 1977 and 2015.

## Precipitation as Reflected in Tree Rings

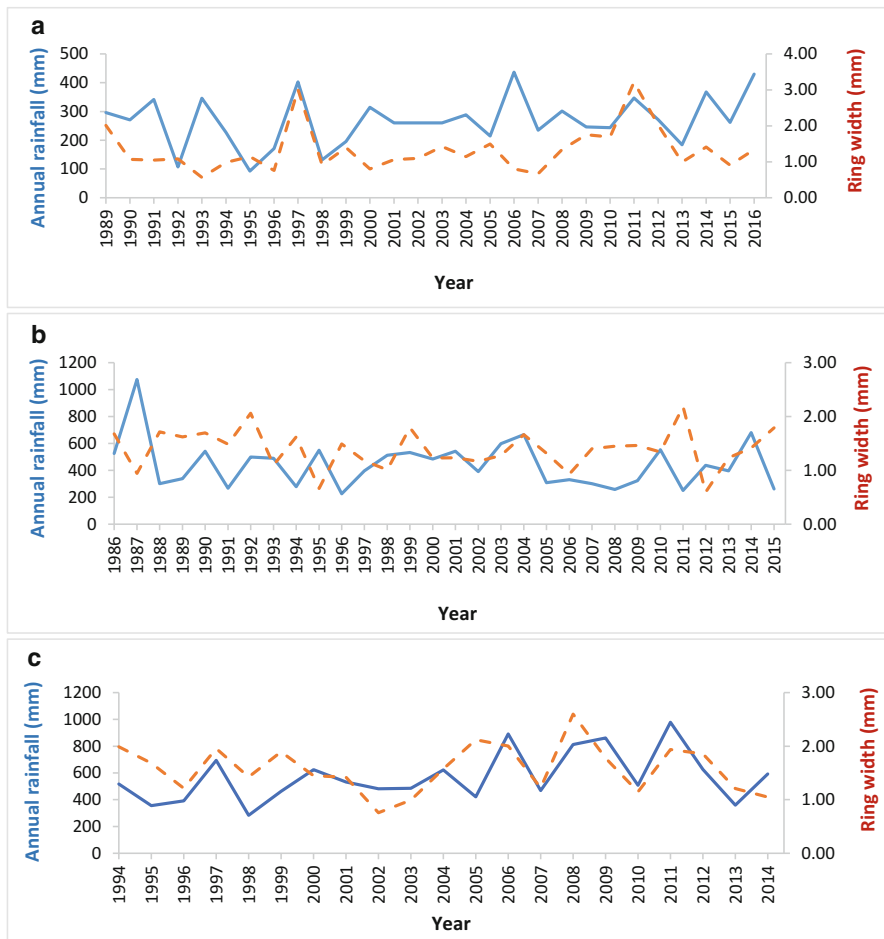
Rainfall in Namibia is unequally distributed, even in years when the country receives good rains, not all areas experience the same precipitation levels. Figure 2 shows the annual rainfall at the three study sites for the years 1970–2014. The rainfall distribution at the three sites follows the national trend where precipitation decreases from north-east to south west (Fig. 1). Figure 2 shows rainfall variability over four decades at the three study sites. At Lake Otjikoto, the annual rainfall was above the average (558 mm) for the years 1972–1974, 1976–1978, 1997, 2001, 2006, 2007–2008, and 2011–2012. At Waterberg, the following seasons had above average (471 mm) precipitation, 1973–1974, 1983–1984, 1987–1988, 2001–2001, and 2013–2014 seasons. Kuzikus has the least number of years with above average rainfall (281 mm), namely, 1973–1974, 1997, and 2006–2007. In decadal terms, the decade 1970–1979 had more rainfall than the 1980–1989 at Otjikoto, whereas the decade 1990–1999 had less rainfall than the 1970–1979 but higher rainfall than the



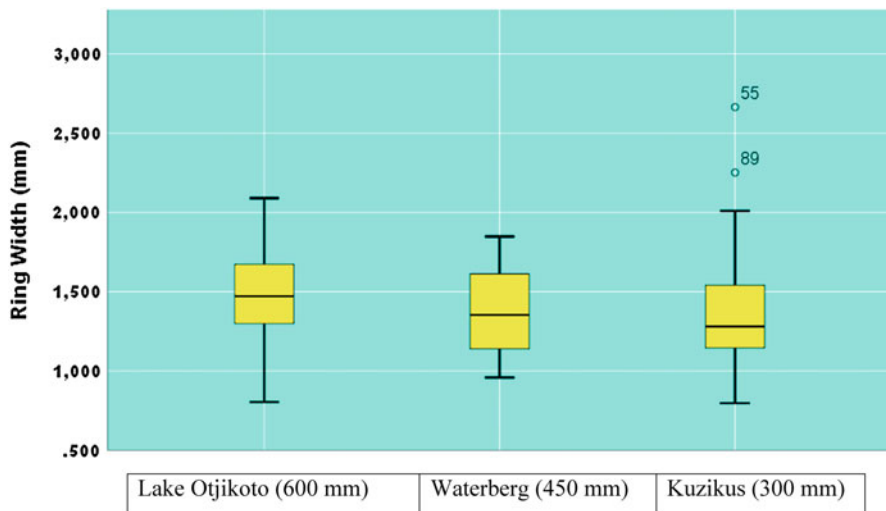
**Fig. 2** Annual precipitation variation over the last four decades for Lake Otjikoto, Waterberg, and Kuzikus

1980–1989 decade. However, the 1990–1999 decade at Otjikoto had a much higher variance than the previous two decades. This feature was much more enhanced in the 2000–2009 decade, where the variability was extreme. For Waterberg, the most variable decade in terms of precipitation was the 1980–1989 decade, followed by the 2000–2009. In the 2000–2009 decade, there was much less rainfall at Waterberg compared with the three previous decades. Kuzikus lies in a semi-arid zone, and precipitation variability is the norm. Kuzikus shows a highly variable precipitation signature over all the four decades.

In Fig. 3a, the growth of *D. cinerea* at Kuzikus (annual rainfall of 250–300 mm/a) shows a positive correlation with rainfall except in years when flooding occurred. At Waterberg (Fig. 3b) and Lake Otjikoto (Fig. 3c), the correlation is also positive. In



**Fig. 3** The relationship between ring widths and annual rainfall *Dichrostachys cinerea* at (a) Kuzikus (300 mm), (b) Waterberg (450 mm), and (c) Lake Otjikoto (600 mm), based on average growth ring of 4 trees per site



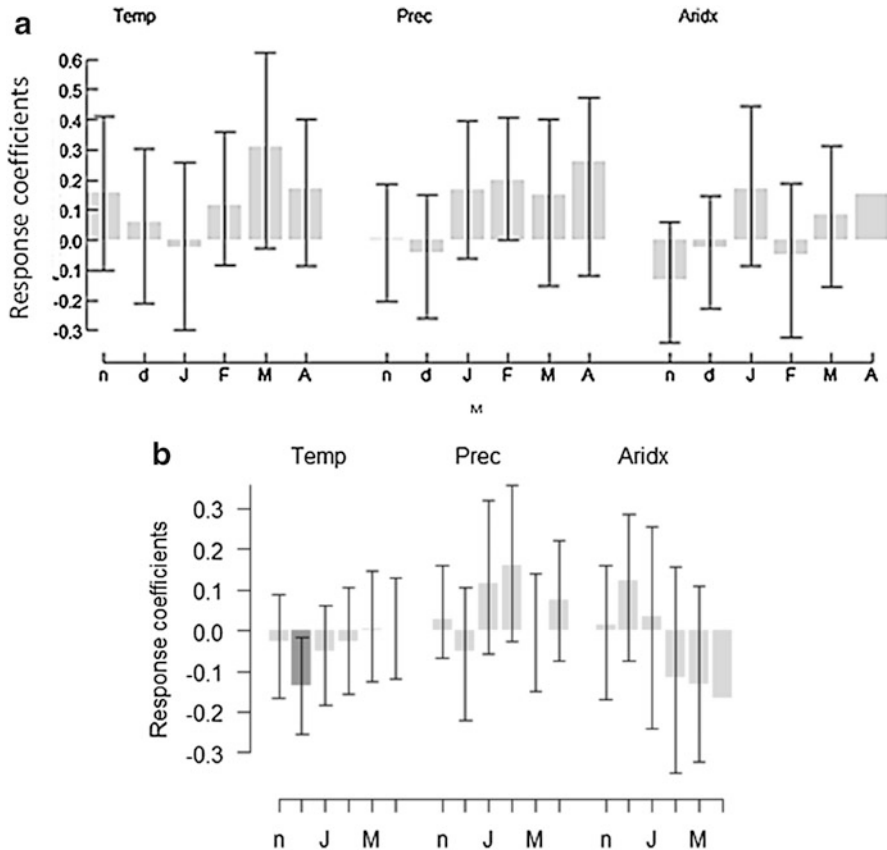
**Fig. 4** Summary of all data from Fig. 3 for the three study sites. The median ring width for Otjikoto is much higher than for both Waterberg and Kuzikus

years when annual rainfall was received over a short period of time, resulting in runoff, the correlation is weak, for example, 2006 and 2016 at Kuzikus, and 1987 and 1995 at Waterberg. Figure 4 summarizes the comparisons in ring width growth across the precipitation gradient. *Dichrostachys cinerea* ring width growth correlates with the amount of precipitation, though the median ring widths did not significantly differ among sites.

## Growth Ring Responses to Climatic Variation

Using bootstrapped correlation function analysis (R Core Team 2018), the darker bars in Fig. 5 indicate a coefficient significant at  $p < 0.05$ , and the lines represent the 95% confidence interval. Figure 5 shows that the response coefficients of temperature, precipitation, and aridity at Lake Otjikoto and Kuzikus sites. The results shows that at Lake Otjikoto, the temperature, moisture availability, and overall aridity have positive but weak influence on growth rings in some months, mainly November and December (temperature), February (temperature and rainfall), and all three variables during March and April months (Fig. 5a). On contrary at Kuzikus, the influence of moisture availability is still positive but to a lesser extent than at Lake Otjikoto (Fig. 5b). The temperature has a significant negative influence in growth rings in December (darker bar, Response Coefficients ( $r$ ) =  $-0.13$ ).

Figure 6 shows the autocorrelation lags of growth ring width with precipitation soil moisture. For Kuzikus, *D. cinerea* in the period 2000–2009 shows a negative correlation, whereas at Waterberg shows an intermediate response to precipitation soil moisture with growth ring width. The growth ring soil-moisture correlations at

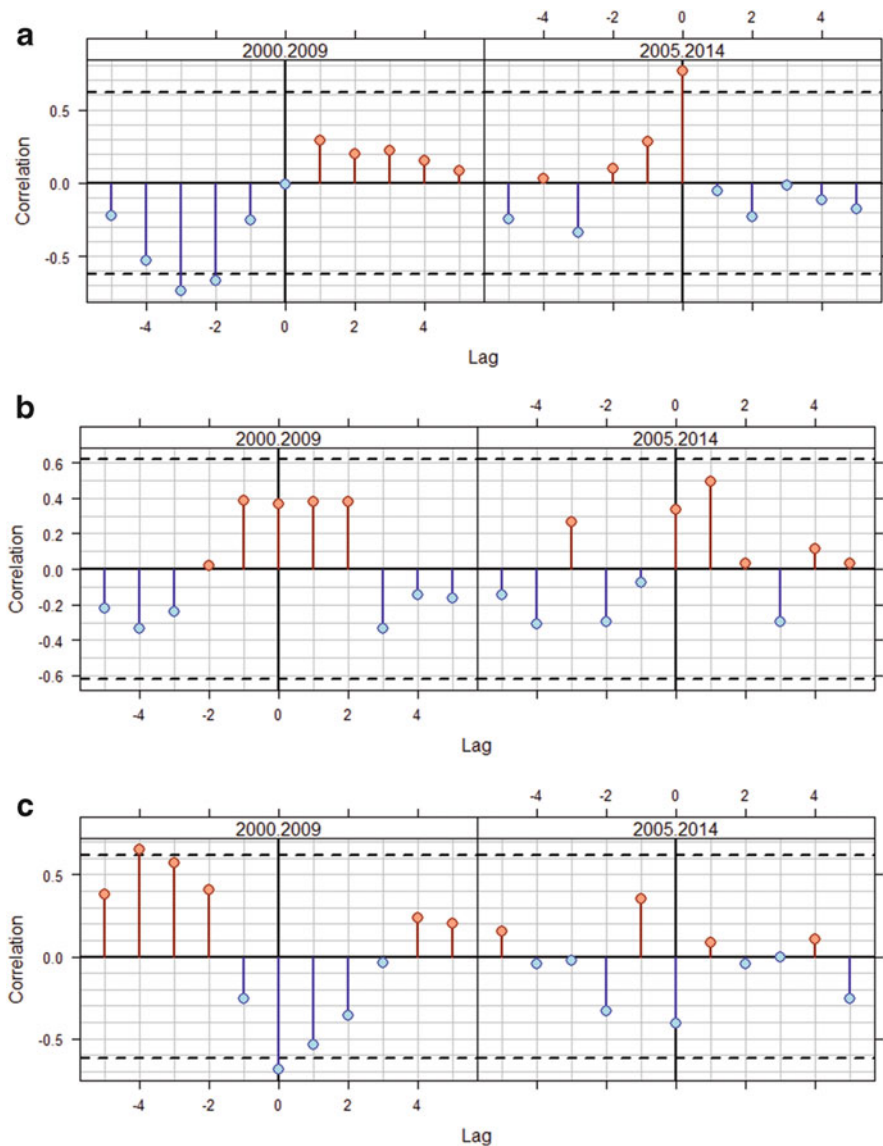


**Fig. 5** (a) Lake Otjikoto site: *D. cinerea* growth ring responsiveness to temperature, precipitation, and aridity (climatic factors affecting tree growth the most). (b) Kuzikus site: *D. cinerea* growth ring responsiveness to temperature, precipitation, and aridity (climatic factors affecting tree growth the most)

Kuzikus where temperatures are high are much weaker compared to the correlations at Lake Otjikoto where rainfall is much higher. Lake Otjikoto shows a very strong positive correlation, way above the normality curve.

## Lessons Learnt from Arid and Semi-arid Savannas

Evidence from precipitation (Fig. 2) and tree growth rings has shown that *D. cinerea* is sympathetic to precipitation soil moisture (Figs. 3, 4, and 5). This relationship is cardinal in the use of tree ring chronologies as proxies to climate variability. Trees are good archives of biomass systematic addition due to their physiological response to water stress that affects growth rings (McCarroll and Loader 2004). Additionally the stomatal conductance is controlled by the relative availability of edaphic



**Fig. 6** Auto correlation lags (1–4) of rainfall with tree ring growth data. Kuzikus in (a) is a much drier and is the opposite of the wetter Otjikoto pattern in (c)

moisture (precipitation) and external leaf water vapor deficit (humidity) (Woodborne et al. 2015). In Namibia, the wet (rain) season used to start at the beginning of November four decades ago; and there has been a slow but gradual and systematic shift to mid-December in the past decade (Shikangalah and Mapani 2019). Such information is available in precipitation and tree ring growth records (Shikangalah et



al. 2020). Work in Southern Africa has now proven beyond doubt that dendrochronology works as good as in the northern hemisphere for certain species of trees (Gourlay 1995; February 2000; Fichtler et al. 2004; Trouet et al. 2006; Woodborne et al. 2015; Shikangalah et al. 2020). Woodborne et al. (2015) reconstructed a 1000 year carbon isotope rainfall proxy record from the South African *Adansonia digitata*.

The key significance of soil moisture supply for the tree growth and its apparent influence is indicated in Fig. 4, where the Lake Otjikoto site with a higher mean annual precipitation shows a much higher ring width growth than at the other two sites. The data illustrate that *D. cinerea* growing in areas with high amounts of rainfall grows wider rings when all other climatic factors are taken together (Fig. 4). The patterns observed in rainfall (Fig. 2) are reflected in the autocorrelation diagrams (Fig. 6) which is a reflection of the microclimate effects on tree growth ring at each particular location. This suggests that *D. cinerea* growth rings can be used as a proxy for climatic variations wherever it is present. This finding is echoed by Kwak et al. (2016) who showed that soil moisture or groundwater near flowing streams influenced tree ring width growth and the size of the rings was proportional to the amount of moisture received.

The results show that in the years when floods occurred (Fig. 3), tree ring width did not correspond to the amount of rainfall received. This fact was attributed to runoff effects, where certain species do not add significant biomass under flooded conditions (e.g., Schulman 1945; Astrade and Bégin 1997; Kwak et al. 2016). Thus, there is an optimum maximum soil moisture threshold for *D. cinerea*.

Southern African species have been for a long time considered as not good at adding biomass systematically on an annual basis. However, tree chronologies for *D. cinerea* and *S. mellifera* were established by Shikangalah et al. (2020). Watkins et al. (2018) showed that tree ring sensitivity to climatic variables is dominated by precipitation. It is abundantly clear that for Southern Africa, Namibia, in particular, tree ring studies are excellent proxies for climate variability studies as they act as natural archives that record site conditions and precipitation effects.

The responsiveness of *D. cinerea* to precipitation, air temperature, and the overall aridity was also examined (Fig. 5). Overall, the response coefficients suggest contrast response of growth rings to climatic conditions at the two sites, with exception of rainfall and aridity in January and February. The low responses are mostly experienced at Kuzikus, while most of the positive responses are experienced at Lake Otjikoto. The response function also showed a precipitation response to a less significant correlation during February to April when the temperatures are cooler after some rainfall. The response coefficients are indicative periods on which the growth rings are quite small, suggesting that *D. cinerea* trees have a very narrow range of responsiveness in which they can grow, therefore supporting the evidence that they add the least amount of biomass in areas of less rainfall such as at Farm Kuzikus (Fig. 4). Due to the lack of darker bars which show a high significant response, these results demonstrate that growth rings are also influenced by other variables such as type of soil, groundwater, and vegetation.

## Conclusions

Growth rings in *D. cinerea* correlate to the amount of precipitation uptake by the species. *Dichrostachys cinerea* is dependent on rainfall for its survival, it has colonized wetter sites (Lake Otjikoto and Waterberg) more than it does in drier sites (e.g., Kuzikus). Therefore, it is much more important for farmers in high rainfall areas to anticipate more encroachment by *D. cinerea* and take necessary interventions to control or manage it. With regard to the usefulness of the species as proxy for modeling climatic conditions, it is concluded that *D. cinerea* is more responsive to climatic variables as it has proportionally responded to the amount of rainfall with ring growth and temperature. At Lake Otjikoto, growth rings are enhanced by both precipitation and temperature, whereas at Kuzikus, only the precipitation improves growth rings, the temperature effects the growth rings negatively. The findings from this chapter suggest that *D. cinerea* can be used as a proxy for precipitation shifts with time over relatively short periods, for instance, of 30- to 50-year histories, and where older trees can be found, it can be used to reconstruct climatic changes over several hundred years.

**Acknowledgments** The authors acknowledge the funding from the OPTIMASS project (01LL1302A), funded by the German Federal Ministry of Education and Research (BMBF). The authors also extend the assistance given by the Alfred Wagner Institute at Potsdam for using the laboratory facilities.

---

## References

- Adhikari U, Nejadhashemi AP, Woznick SA (2015) Climate change and eastern Africa: a review of impacts on major crops. *Food Energy Secur* 4:110–132
- Astrade L, Bégin Y (1997) Tree-ring response of *Populus tremula* L. and *Quercus robur* L. to recent spring floods of the Saône River, France. *Ecoscience* 4:232–239
- Barnard P (2012) Water and climate change, IBA Newsletter 2. Spring, p 3
- Biondi F, Waikul K (2004) DENDROCLIM2002: a C++ program for statistical calibration of climate signals in tree-ring chronologies. *Comput Geosci (UK)* 30:303–311
- Breitenmoser P, Brönnimann S, Frank D (2014) Forward modelling of tree-ring width and comparison with a global network of tree-ring chronologies. *Clim Past* 10:437–449
- Bunn AG (2008) A dendrochronology program library in R (dplR). *Dendrochronologia* 26:115–124. <https://doi.org/10.1016/j.dendro.2008.01.002>
- Chepape RM, Mbatha KR, Luseba D (2011) Local use and knowledge validation of fodder trees and shrubs browsed by livestock in Bushbuckridge area, South Africa. *Livest Res Rural Dev* 23:132. Available from: <http://www.lrrd.org/lrrd23/6/chep23132.htm>. Accessed 15 Aug 2018
- February EC (2000) Archeological charcoal and dendrochronology to reconstruct past environments of Southern Africa. *S Afr J Sci* 96:111–116
- Feliksik E, Wilczyński S (2009) The effect of climate on tree-ring chronologies of native and nonnative tree species growing under Homogenous site conditions. *Geochronometria* 33:49–57
- Fichtler E, Trouet V, Beeckman H, Coppin P, Worbes M (2004) Climatic signals in tree rings of *Burkea africana* and *Pterocarpus angolensis* from semiarid forests in Namibia. *Trees* 18 (4):442–451

- Food Agricultural Organisation (FAO) (2005) Namibia: irrigation in African in figures. Aquastat Survey. Retrieved from. [http://www.fao.org/nr/water/aquastat/countries\\_regions/NAM/NAM-CP\\_eng.pdf](http://www.fao.org/nr/water/aquastat/countries_regions/NAM/NAM-CP_eng.pdf)
- Gourlay ID (1995) Growth ring characteristics of some African *Acacia* species. *J Trop Ecol* 11:121–140
- Grissino-Mayer HD (2001) Evaluating crossdating accuracy: a manual and tutorial for the computer program COFECHA. *Tree Ring Res* 57:205–221
- Grudd H (2006) Tree rings as sensitive proxies of past climate change. PhD dissertation. Stockholm University
- Gumbo B (2003) The status of water demand management in selected cities of Southern Africa. In: WaterNet/Warfsa symposium: water, science, technology & Policy convergence and action by all, vol. 7, pp 1–7. <http://www.sciencedirect.com/science/article/pii/S1474706504001913>
- Heinrich I, Weidner K, Helle G, Vos H, Lindesay J, Banks JCG (2009) Inter-decadal modulation of the relationship between ENSO, IPO and precipitation: insights from tree rings in Australia. *Clim Dyn* 33(1):63–73
- Holmes RL (1983) Computer-assisted quality control in tree-ring dating and measurement. *Tree-Ring Bull* 43:69–78
- Intergovernmental Panel on Climate Change (IPCC) (2007) Climate change 2007: the physical science basis. Agenda 6(07):333. <http://www.slvwd.com/agendas/Full/2007/06-07-07/Item%2010b.pdf>
- Intergovernmental Panel on Climate Change (IPCC) (2015) In: Pachauri RK, Meyer LA (eds) Climate change 2014 synthesis report. Contributing of Working Groups: I, II and III to the Fifth Assessment Report of the International Panel on Climate Change. IPCC, Geneva. 155pp. <https://doi.org/10.1017/CBO9781107415324>
- Křibek B, Sipkova A, Ettl V, Milhaljevic M, Majer V, Knésl I, Mapani B, Penizek V, Vanek A, Sracek O (2018) Variability of copper isotopic composition in soil and grass affected by mining and smelting in Tsumeb, Namibia. *Chem Geol* 493:121–135
- Kwak J, Kim S, Kim G, Singh VP, Park J, Kim HS (2016) Bivariate drought analysis using streamflow reconstruction with tree ring indices in the Sacramento Basin, California, USA. *Water* 122. <https://doi.org/10.3390/w8040122>
- Lafforgue M (2016) Supplying water to a water-stressed city: lessons from Windhoek. *La Houille Blanche* 4:40–47. <https://www.shf-lhb.org/articles/lhb/abs/2016/04/lhb2016038/lhb2016038.html>
- Mapani BS (2005) Groundwater and urbanisation, risks and mitigation: the case for the city of Windhoek, Namibia. *Phys Chem Earth* 30(11–16):706–711. <https://doi.org/10.1016/j.pce.2005.08.011>. SPEC. ISS
- Mapaure I (2016) Review of climate change in Namibia: projected trends, vulnerability and effects. In: Ruppel OC, Ruppel-Schlichting K (eds) Environmental law and policy in Namibia: towards making Africa the tree of life. Fully Revised and Updated Third Edition. Hanns Siedel Foundation, Windhoek, pp 339–358. ISBN 978–99945–79–88–4
- McCarroll D, Loader NJ (2004) Stable isotopes in tree rings. *Q Sci Rev* 23(7):771–801
- Mendelsohn J, Jarvis A, Roberts C, Robertson T (2002) Atlas of Namibia: a portrait of land and its people, vol 53. David Philip Publisher. <https://doi.org/10.1017/CBO9781107415324.004>
- National Aeronautics and Space Administration (NASA) (2008) Global climate change and global warming: vital signs of the planet. Jet Propulsion Laboratory/National, CA, United States
- Nock CA, Metcalfe DJ, Hietz P (2016) Examining the influence of site conditions and disturbance on rain forest structure through ring analyses in two Araucariaceae species. *For Ecol Manag* 366:65–72
- Novak K, de Luis M, Raventos J, Cufar K (2013) Climatic signals in tree-ring widths and wood structure of *Pinus halepensis* in contrasted environmental conditions. *Trees* 27(4):927–936. <https://doi.org/10.1007/s00468-013-0845-5>
- O'Connor TG, Puttick JR, Hoffman MT (2014) Bush encroachment in Southern Africa: changes and causes. *Afr J Range Forage Sci* 31:67–88. <https://doi.org/10.2989/10220119.2014.939996>

- Ohlsson L, Turton AR (1999) The turning of a screw: social resource scarcity as a bottle-neck in adaptation to water scarcity. Occasional paper series. School of Oriental and African Studies Water Study Group. University of London, London. [https://dlc.dlib.indiana.edu/dlc/bitstream/handle/10535/5189/WF1-00\\_Social\\_Resource\\_Scarcity\\_as\\_a\\_Bottle-Neck.pdf](https://dlc.dlib.indiana.edu/dlc/bitstream/handle/10535/5189/WF1-00_Social_Resource_Scarcity_as_a_Bottle-Neck.pdf)
- Orwa C, Mutua A, Kindt R, Jamnadas R, Anthony S (2009) Agroforestry database: a tree reference and selection guide version 4.0. Available from: <http://www.worldagroforestry.org/sites/treedbs/treedatabases.asp>. Accessed 14 Sep 2018
- Palmer JG, Turney CSM, Fogwill C, Fenwick P, Thomas Z, Lipson M, Jones RT (2018) Growth response of an invasive alien species to climate variations on subantarctic Campbell Island. *N Z J Ecol* 42(1):31–39. <https://doi.org/10.20417/nzjecol.42.2>
- R Core Team (2018) R: a language and environment for statistical computing. Vienna, Austria, 0. Retrieved from <https://www.r-project.org/>
- Reid HL, Stage J, MacGregor J (2007) The economic impact of climate change in Namibia: economic program discussion paper 07–02. International Institute for Environmental and Development, London
- Rodgers M, Bilton M, Hauptfleisch M (2017) Responses and feedbacks of burrowing mammals under differently managed rangelands. *Namibian J Environ* 1(A):40–51
- Ruth M, Bernier C, Jollands N, Golubiewski N (2007) Adaptation of urban water supply infrastructure to impacts from climate and socioeconomic changes: the case of Hamilton, New Zealand. *Water Resour Manag* 21(6):1031–1045. <https://doi.org/10.1007/s11269-006-9071-x>
- Schulman E (1945) Runoff histories in tree rings of the Pacific slope. *Geogr Rev* 35:59–73
- Seckler D, Barker R, Amarasinghe U (1999) Water scarcity in the twenty-first century. *Int J Water Resour Dev* 15(1–2):29–42. <https://doi.org/10.1080/07900629948916>
- Shanyengana ES, Seely MK, Sandersen RD (2004) Major-ion chemistry and groundwater salinization in ephemeral floodplains in some arid regions of Namibia. *Namibian J Environ* 57:71–83
- Shikangalah RN, Mapani BS (2019) Precipitation variations and shifts over time: implication on Windhoek city water supply. *Phys Chem Earth* 112:103–112
- Shikangalah R, Mapani BS, Mapaure I, Herzs Schuh U, Musimba A, Tabares X (2020) Growth ring formation of *Dichrostachys cinerea* and *Senegalia mellifera* in arid environments in Namibia. *Dendrochronologia* 59:125661
- Showers KB (2002) Water scarcity and urban Africa: an overview of urban-rural water linkages. *World Dev* 30(4):621–648. [https://doi.org/10.1016/S0305-750X\(01\)00132-2](https://doi.org/10.1016/S0305-750X(01)00132-2)
- Steenkamp CJ, Vogel JC, Fuls A, Van Rooyen N, Van Rooyen MW (2008) Age determination of *Acacia erioloba* trees in the Kalahari. *J Arid Environ* 72(4):302–313
- Trouet V, Coppin P, Beeckman H (2006) Annual growth ring patterns in *Branchistegia speciformis* reveal influence of precipitation on tree growth. *Biotropica* 38(3):375–382
- Turpie AJ, Midgley G, Brown C, Barnes J, Pallett J, Desmet P et al (2010) Climate change vulnerability and adaptation assessment for Namibia's biodiversity and protected. Ministry of Environment and Tourism, Directorate of Parks & Wildlife Management, Windhoek
- Wang Y, Xiao H, Wang R (2009) Water scarcity and water use in economic systems in Zhangye city, north olwestern China. *Water Resour Manag* 23(13):2655–2668. <https://doi.org/10.1007/s11269-009-9401-x>
- Watkins K, Patterson T, Knapp T (2018) Investigating the climatic sensitivity of Shortleaf Pine on a southeastern US College campus. *Southeast Geogr* 58(2):146–163
- Woodborne S, Hall G, Robertson I, Patrut A, Rouault M, Loader NJ, Hofmeyr M (2015) A 1000-year carbon isotope rainfall proxy record from South African Baobab trees (*Adansonia digitata* L.)
- Xing P, Zhang Q, Baker PJ (2012) Age and radial growth pattern of four tree species in a subtropical forest of China. *Trees* 26:283–290
- Zang C, Biondi F (2013) Dendroclimatic calibration in R: the bootRes package for response and correlation function analysis. *Dendrochronologia* 31(1):68–74
- Zang C, Biondi F (2015) Treeclim: an R package for the numerical calibration of proxy-climate relationships. *Ecography* 38(4):431–436

- Zeidler J, Kandjinga L, David A (2010) Study on the effects of climate change in the Cuvelai Etosha Basin and possible adaptation measures. Integrated Environmental Consultants Namibia. A technical Report for the Cuvelai Basin
- Zhang Z (2015) Tree-rings, a key ecological indicator of environment. *Ecol Indic* 51:107–116

**Open Access** This chapter is licensed under the terms of the Creative Commons Attribution 4.0 International License (<http://creativecommons.org/licenses/by/4.0/>), which permits use, sharing, adaptation, distribution and reproduction in any medium or format, as long as you give appropriate credit to the original author(s) and the source, provide a link to the Creative Commons license and indicate if changes were made.

The images or other third party material in this chapter are included in the chapter's Creative Commons license, unless indicated otherwise in a credit line to the material. If material is not included in the chapter's Creative Commons license and your intended use is not permitted by statutory regulation or exceeds the permitted use, you will need to obtain permission directly from the copyright holder.





# Just Societal Transformation: Perspectives of Pastoralists in the Lower Omo Valley in Ethiopia

# 118

Sabine Troeger

## Contents

Transformation Toward Sustainability in Terms of Social Justice: Two Perspectives in Ultimate Dependence .....	2448
The Climate Change Imperative as Perceived and Acted upon by Pastoral Communities: The Global Scale .....	2451
The “Committee”: A Pathway Toward Climate Change Adaptation and Mitigation? – The National Scale .....	2453
Large-Scale Investment, Irrigation, and Villagization: Opening the “Ground” to the State – The Regional Scale .....	2458
Climate Services, Pathways Toward Processes of Beneficial Societal Transformation? – The Local Scale .....	2461
Conclusion .....	2464
References .....	2465

## Abstract

Pastoralists’ livelihoods in Africa are highly endangered by adverse forces – the climate change being one among those. Against this background, climate change adaptation is conceptualized as strategic agency in the field of risk-laden livelihood environments, that is, agency in the face of risky options and non-calculable uncertainties.

The chapter conceptualizes pastoralists’ livelihoods exposed to a four-fold hierarchy of environmental risks and forces defining the actors’ arena of strategic decision making: From the global scale of ever extending impacts by the climate change imperative, to the national scale of government policies in terms of decentralization, challenging people to govern and define their communal

---

S. Troeger (✉)

Department for Development Research, Geography Institute, University of Bonn, Bonn, Germany  
e-mail: [troeger@geographie.uni-bonn.de](mailto:troeger@geographie.uni-bonn.de)

© The Author(s) 2021

W. Leal Filho et al. (eds.), *African Handbook of Climate Change Adaptation*,  
[https://doi.org/10.1007/978-3-030-45106-6\\_265](https://doi.org/10.1007/978-3-030-45106-6_265)

2447

efforts in terms of climate change adaptation, and down to the regional scale, which in the presented case is dominated by a large-scale investment, the Kuraz Sugar Development Project, which again confronts local actors with adverse forces toward villagization and eviction from pasture grounds. Right at the end of this hierarchy and in accordance with discourses on “climate services,” the end-users and local actors, the pastoralists, are confronted with and offered a product that they can input into their decision making: cattle feed from the residues of the irrigated sugar cane. The question remains whether substantive aspects of processes turning into true environmental and social justice in terms of recognition, procedures, and distribution will be paid attention to.

---

**Keywords**

Societal transformation · Climate services · Environmental justice · Riskscales · Decentralization · Land grabbing

---

**Transformation Toward Sustainability in Terms of Social Justice: Two Perspectives in Ultimate Dependence**

The notion of transformation is increasingly promoted in scientific and likewise popular discourses as a solution to unsustainable practices. Transformations toward sustainability are needed to address many of earth’s profound environmental and social challenges. In transformational adaptation literature the distinction between incremental adjustments and transformational responses is to be found. As defined by the IPCC-Report 2018: “Global Warming of 1.5 °C,” incremental transformation refers to some means and instruments of “adaptation that maintains the essence and integrity of a system or process at a given scale,” while “transformational adaptation implies ‘changes of fundamental attributes of a socio-ecological system.’” A transformative response to obviously unsustainable circumstances of life, be these ecologically or socially based, will require engaging with the root causes of inequality and likewise environmental degradation, which necessitates some transformational adaptation in the indicated sense. Furthermore, actions taken to shift socio-ecological systems toward more sustainable pathways can have substantial social impacts and may exclude members of communities from decisive processes.

The named perspective emphasizes the importance of contesting dominant social and political structures, rather than accommodating change to address the root causes of unsustainable systems and catalyze genuinely alternative futures. Transformations toward sustainability can only be taken as a success in case social justice is considered a central concern. In consequence, all actions taken to shift toward environmental sustainability can have both positive and negative social

implications for different groups relative to the status quo, which means attention is needed to both understanding and realizing social justice during sustainability transformation (Temper et al. 2018). Following this notion three dimensions of justice are to be differentiated: (a) recognitional justice in acknowledgment of and respect for preexisting governance arrangements as well as the distinct rights, worldviews, knowledge, needs, livelihoods, histories, and cultures of different groups in decisions; (b) procedural justice with reference to the level of participation and inclusiveness of decision making and the quality of governance processes, and c) distributional justice, which can be defined as fairness in the distribution of benefits and harms of decisions and actions to different groups across space and time (Bennett et al. 2018).

Following the vision to turn scientific information from climate monitoring, research and modeling into operationally available information and services that would help societies to cope with climate variability and change, the World Meteorological Organization (WMO) launched the process for developing the Global Framework for Climate Services (GFCS) at the World Climate Conference (WCC) in September 2009. This conference recognized ongoing discourses on the unambiguous importance and relevance of climate services, which were considered essential to adaptation to environmental and climate variability and change (European Commission 2014). Climate services are to be seen as one essential contribution and element of transformations toward sustainability. But at the same time the perspective of climate justice identifies climate services as the source of a double inequality with a distribution of risk and responsibility (Adger et al. 2006, 2009). Climate services will mitigate the impacts of climate-related stresses, while the end-users' perspective is a key in tailoring the service measures ([climate-services.org](http://climate-services.org)).

Against the background of these generalizing recognitions with relation to societal transformation in terms of environmental justice the chapter aims to explore the implications of present day environmental dynamics, the climate change intertwined with market and governance perspectives exemplified in their concretized meaning for pastoralism and pastoralist livelihoods in the Lower Omo Valley right in the south of Ethiopia: The Lower Omo Valley, until 2011 one of the most peripheral and likewise politically neglected regions of Ethiopia, has turned into a hotspot of societal transformation geared by natural, social, economic, and cultural forces. Home to 16 ethnic agro-pastoralist societies (recognized UNESCO World Cultural Heritage in 1980), formerly well adapted to the fragile semiarid environment of the lowlands, the Lower Omo Valley is nowadays highly impacted by irrevocable and fundamental changes in livelihood constellations caused by forces in a four-fold global to local scale gearing toward some ultimate and irrevocable societal transformation, that is, processes, which hold a strong grip on those ethnicities calling the Lower Omo Valley their home in terms of fundamentally re-defining the constituents of livelihood systems as of at present. With reference to the initial perspective of the chapter the argument will pose the

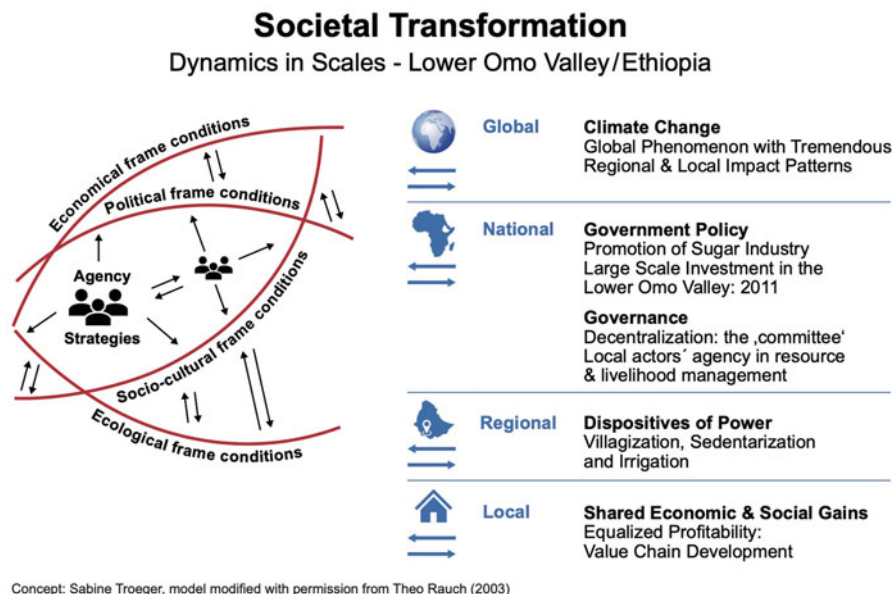


question in how far and to which degree processes of transformation to be observed in the Lower Omo Valley are to be taken as sustainable, which includes the perspective of justice with reference to the addressed ethnicities, the pastoral communities in their distinct and unique representation.

Grounded on actor oriented and constructivist reasoning the chapter subsequently relates to the perspective of human agency in the face of risky environments. Following Appadurai's concept of spatiality (1990), when he coins five terms with the suffix "-scape" indicating the ambiguity and fluidity of social phenomena, the chapter interprets agency by people in the context of their "social constructions" of their environments. The argument relates to the idea of "riskscapes" as defined by Mueller-Mahn and Everts (2018). Riskscapes are intertwined with social practices. The focus on practices posits that understanding human activity is key to any deeper knowledge of events and states. Schatzki (2002) emphasizes the fact that any practice involves various people and is always part of a larger set of socially ordered actions, highlighting the dynamic nature of social practices, how they change and how they relate to spatial and temporal dynamics. The argument follows Schatzki (2012:14), when he says, "a practice (. . .) is an open ended, specially temporally dispersed nexus of doings and sayings." Based on this recognition the concept of "riskscapes" refers to temporal-spatial phenomena that relate risk, space, and practice. Riskscapes link the material dimension of physical threats, like for example the climate change, the discursive dimension of how people perceive, communicate and envision risks, and the dimension of agency, that is, how people produce risks and manage to live with them. In consequence, risks are not to be taken "objectively given" phenomena, but are shaped and constantly modified through practices, which are socially embedded. Thus, observations in the field and with representatives of the communities in focus are to be understood in terms of agency in recognition of people's perceptions, interpretations, and evaluations of their environments.

The chapter elaborates on four perspectives of given environmental – natural as well as social and sociopolitical – constellations and livelihood frameworks in scales in the Lower Omo Valley. The argument will draw the attention to two comprehensive conclusions of these observations and assessments in the field, to subsequently link these with regional forces in terms of villagization and sedentarization policies, which are taken as "dispositives" as understood by Foucault (1977). In line with this understanding, present and pressing development perspectives are outlined, which highly challenge and tackle the field of environmental justice. Concluding, the argument will revise the field and discursive findings with relation to the four analytical scales and suggest some rounding up picture of the observed societal processes in terms of a transformation answering the claim to social justice.

**Figure I** titled "Societal Transformation" illustrates the above referred to analytical concept in scales:



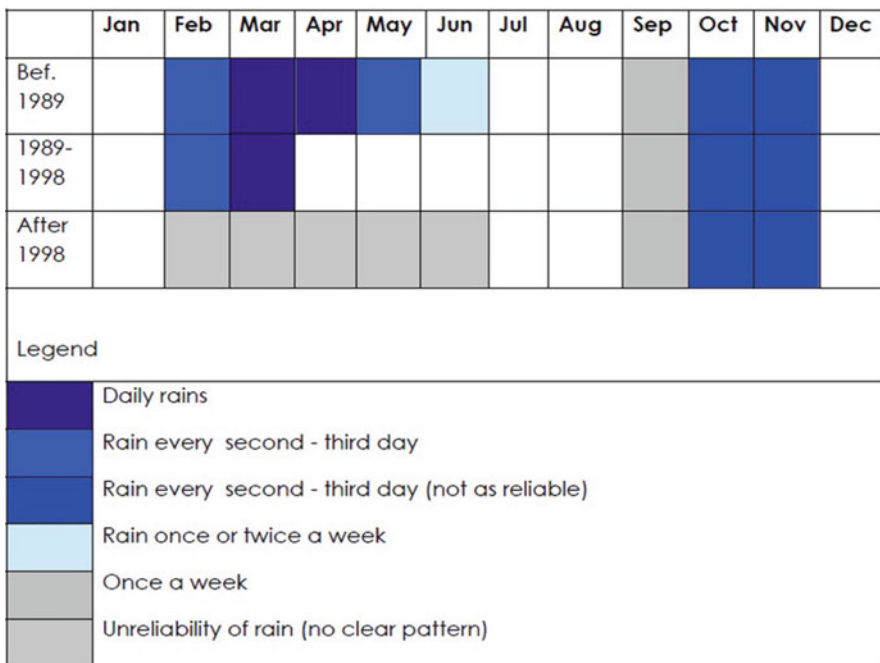
**Figure I:** Societal Transformation, Dynamics in Scales – Lower Omo Valley/Ethiopia (source: Concept Sabine Troeger, model modified with permission by Theo Rauch – 2003)

## The Climate Change Imperative as Perceived and Acted upon by Pastoral Communities: The Global Scale

Data from the field leave no room for doubt about the severity of ongoing and in the course of time further enforced climate change impacts in the Ethiopian Lowlands (Troeger et al. 2012). The Lower Omo Valley, located in the southern part of these lowlands, is highly exposed to a climate change pattern characterized by considerably shortened *Belg* rains as part of the customary rainfall pattern. These were formerly expected to be starting end of February or early March and lasting until end of May or beginning of June. The eastern and southern regions of Ethiopia, demarcated by the Rift Valley, are highly dependent on this specific rainfall pattern for their annual agricultural production as well as their migratory routes with their livestock, which in this case is cattle, whereas the goats and sheep, the smaller ruminants, remain with the women, the wives, children, and elderly people. They will feed on the pastures and bush-vegetation in the vicinity of the homesteads, which are rhythmically shifted within a radius of some kilometers but remain in line with the pastoralist livelihood system more or less concentrated on some an ethnically defined neighborhood.

At the time of the field assessment the pastoralists discussed the spatial and quantitative changes of temperature, precipitation and floods. To their perception,

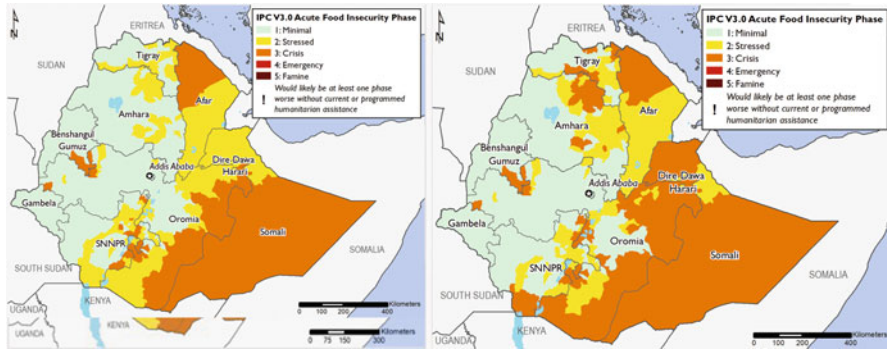
all of these un-contradictorily stated deviations and irregularities in rainfall started around the year 1989 and since then have shown a gradual decline in precipitation. More severe changes were perceived to have started after 1998 and culminated for the first time in the year 2011, when large parts of the Horn of Africa were struck by one of the worst droughts ever recorded in 60 years, which translated into a severe food crisis. In July 2011, the United Nations declared a famine, but already as early as January 2011, considerable heads of livestock had died, as reported by the people. The drought that started in 2011, whether it was caused by global climate change factors or the effect of a very harsh La Niña event as suggested by IRIN News (15 July 2011), took place in the wake of 4–5 years of more or less failed *Belg* rains, as summarized to be a general trend by the diagram below:



**Figure II:** The Climate Change pattern as perceived and acted upon by the people. (Source: Troeger et al. 2012)

*“Everything that is happening now, is beyond our capacity”* was the unisonous statement of the people, be these young or old, when talking to them in the field. The conclusion drawn by Moro, at that time Nyangatom women leader, summarizes the research findings (Troeger et al. 2012) and unambiguously indicates a livelihood configuration highly at risk, going hand in hand with a dissolution of beforehand sustainable codes of conduct, namely the indigenously established “culture of sharing,” when people deliberately and spontaneously shared food and further agricultural produce and items (Troeger 2016b & 2018).

A concordant climate change pattern showed the precipitation and subsequent constellations of food crises in the past year, the year 2019, which can be taken as an indication of the further continuing decline in and unreliability of rainfall:



**Figure III:** Patterns of food Insecurity in the wake of deficit precipitation in the Lowlands – the year 2019. (Source: with permission by Famine Early Warning Systems Network (FEWS.net))

Moving back to the initial question of people and pastoralists in confrontation with processes of environmental risk and transformation, pastoralists in the Lower Omo Valley see themselves and are to be taken as threatened beyond their formerly established coping potential. According to their reports the young herders could not follow their seasonal migratory pattern among other things. There were reports about young herders, who stayed away from their culturally manifested neighborhood for several seasons in succession. People were worried about these environmental tendencies and complained that, as the weather got drier and it became increasingly difficult to survive, neighborhoods fell apart, people abandoned their traditions and were forced to accept other lifestyles (Troeger et al. 2012).

## The “Committee”: A Pathway Toward Climate Change Adaptation and Mitigation? – The National Scale

Turning to the national level, the argument moves on from the following observation:

Following the agenda of the government, the claim of “development” has always been and is as well with the new policies guided by the present Prime Minister Abiy Ahmed the directive of the rulers of the state. Governments’ interventions labeled NRM, natural resource management, combine hegemony and governmentality projects to conform citizens into its governmental state ideology. While local governments continue to be representatives of the controlling apparatus of the political elite rather than representatives of interests of their constituents (Ayele 2011), they will follow the “development narrative.” Party loyalty is demonstrated by adopting agricultural ideas promoted by the state, which is indicated by Lefort (2012), who suggests that so-called model farmers are rather party agents instead of famers with high agricultural competence.

Based on this insight the political role of “committees,” coinciding with the claim for decentralization all over Africa and together with the mainstreaming of participatory approaches in development practice, is to be questioned. Do communities experience a shift in policies to advocate local actors and resource users and play a more active role in natural resource management (NRM), which in many cases today is to be understood as climate change adaptation (CCA)? Decentralization in general describes the process by which bundles of entrustments, like regulatory and executive powers, responsibility and authority in decision-making, are transferred to local agents, which again calls for new institutions and processes of institution building, that is, the committees. The following argument digs deeper into this perspective of local policies and into the perspective of “handing over the stick,” the guiding principle of the participatory approach in development practice PRA and of governance in local contexts. And at this point, the question of environmental justice becomes vital as the impact of decentralization is to be measured with respect to recognitional, procedural, and distributional just and fair outcomes relating to actors and activities on the local scale.

The targeted processes of decentralization come about in the shape of “committees,” that is, institutional settings, which have mushroomed up in various development contexts all over Africa. Activities of the “Western” ideal of democracy in the shape of committees focus in general environments of obvious global change, which force local actors to unanimously and fundamentally adapt to the irreversible changes in nature. Informed by this perspective, the committees mirror the principal idea of equal representation and equal voice. Per definition has the ideal of “participation” developed to be the counter-balance to the sociopolitical institution of “committees,” which again claims to “give people a voice.” In consequence, the notion of “voice” unambiguously links the concepts of “committee” and “participation” with the need for “communication,” true communication, which enables intersubjectivity via a mutual exchange of people’s perceptions, interpretations, and valuations, in short: social constructions. In summary, committees are taken to be the platform for participation in realization of the demand for “communication” regarding “giving people a voice.”

Corresponding with Government policies in promotion of sustainable and decentralized community development in Ethiopia, a “committee” has been established with the Nyangatom community. The Nyangatom are one of the 16 ethnicities in regional focus. Their committee was explicitly established to safeguard and control the recently established scheme of rangeland enclosures in support of climate change adaptation needs in terms of referred to propagated improved land use techniques. Rangeland enclosures, enclosed by bush thorn fences, are manifestations of private landownership, which excludes members of the community from participating in the advantages of the protected grazing areas behind the fences. In consequence, parts of the former “commons” are claimed by the powerful representatives of the communities. The committee was first installed in order to govern the new scheme on local grounds and resist against the powerful take over by some community members. But very soon after it was appropriated by Government employees, by “experts” from Addis Ababa.

In contradiction to the outlined and to our “Western European” eyes normalized and customized ideal of democracy the established committee meets societal constellations on the ground, which had known and were based on some means and ways of mutual consensus finding by their own constitution. The Nyangatom, one of the unique pastoralist ethnic groups of Ethiopia’s south, situated in the Lower Omo Valley, numbering about 10,000 people, has like its neighboring pastoralist communities, ever since been guided by an “age-group system.” The system is constituted by five age groups: children, youths, herders of 25–50 years, the political class of the “elephants” aged 50–65 years, and the very old and wise men in the role of spiritual guides, as explained by two community guides:

The elders used to manage the grazing land by telling the herders to shift from pasture to pasture. They sent young herders to check the condition of the grass, and then they decided on the migration paths. If someone was seen taking his animals to the forbidden areas, he would be punished. But punishment is not constant. It will vary from people to people and it depends on the severity of the action. But it as well respects the livelihood constellation of the trespasser and defines the punishment in accordance. (Soya Kurupa, man – 14 March 2015, approx. 42 years) (Troeger 2018)

The cultural management has no written rules and regulations, because once the elders pass the decision, no one will disobey. It is a management, where everyone has to obey. We have grown up with it, so we like it very much. (Moru Lomarle, woman – 12 March 2015, approx. 55 years) (Troeger 2018)

Interpreting village-level ethnographic data from the named pastoralist livelihood scenery, the case of the Nyangatom, the chapter supports the following thesis: The formula of “transformative adaptation,” as propagated by, for example, the 5th IPCC assessment report 2014 and likewise by the report on “Global Warming of 1.5 °C” (see above) with some successful climate change adaptation in view, and subsequently multifold suggested by initiatives hailing processes of societal transformation, does not necessarily gear toward a change in the name of a more resilient and sustainable development. Field data reflect on interpretations and perceptions by the pastoralists involved relating to this transformative impetus. They indicate “disagreement in the shadows” as defined by Rancière (1998), and a disruption of processes of communication and mutual cooperation. With this portrayal Rancière indicates some community constellations, which do not allow for open resistance but only offer some hidden away and not openly articulated opposition (*ibid.*).

Listening to the people, to “the people’s voice,” reveals the true process lines of the committee meetings and offers the chance to get closer to the meaning of “governance” and “participation” facilitated by processes of communication in given frameworks of the committee. Perceptions and interpretations are singled out in line with the perspectives of: “structural forces and governance,” “modes of participation,” and “articulation of social correctness.”

I myself had the idea of establishing rules to govern our problems with the drought and the use of the pastures, but then I heard that the Woreda people are coming to establish the rules and regulations. And there were some people from Addis Ababa, who gave us some papers,

which listed the rules. They asked the people to add on it, and of course, everything was clear, and nobody added anything on top of the by-laws, and the committee was selected from different age-groups. (Lobowa, approx. 42 years – 14 March 2015) (Troeger 2016b & 2018)

Quite in line with the general articulation of the “development narrative” in Ethiopia, obviously no participation, which could indicate true “governance,” had been sought. The community member claims initially own, self-determined ideas about necessary regulations, but he had no chance to promote these tentative frameworks of governance. No “freedom to articulate one’s own voice” is given in this process of communication. No recognitional nor procedural justice is given to him and his ideas. He is neither respected in his worldviews, knowledge, and needs, nor is there any true chance for true participation offered to him. The message from the district and national governance representatives turns out to be an unambiguous top-down message, which has to be “swallowed” by the people on the ground, by those, who in future would be the ones to realize these handed over regulations. Structural forces govern the information instead of true communication processes. No communication in the ideal sense is realized, which is even more emphasized by the following statements:

Us elders, we were unsure whether to accept the new rules, but the Woreda people made us accept the idea of bye-laws. (Dida Lolibes, man – 11 March 2015, approx. 64 years) (Troeger 2018)

The leaders from the Woreda and the people from Addis made us discuss the question of the punishment for not following the rules. So, the discussions were led by the experts, and they were the ones to give a speech on the positive side of the new governance system and make the community accept the idea. Even me, I accepted it. (Ariapa Lokitibo, man – 14 March 2015, approx. 38 years) (Troeger 2018)

By listening to the people’s voice it becomes obvious that the modern idea of committees will not match with the culturally established and believed in articulation of authority and representation. The idea puts the indigenous identity at risk. The articulated obedience toward culturally manifested rules represents customary regulations and a sense of belonging and identity. Especially the emphasis on a fair, socially reflected and balanced execution of established rules and regulations contrasts the perception of today’s realization of power and authority. The obvious notion of “disagreement” indicates a situation, when meant to be partners in communication do not necessarily contradict each other openly but disagree in the shadow of claimed consensual modes of governance. On the surface, this consensual governance has reduced political conflict and disagreement (Swyngedouw 2011), but in reality, the partners in communication have not reached a common ground of understanding. “Disagreement in the shadow” should be taken to the open and made understandable to all. The new challenges and arrangements with relation to the range enclosures and in consequence processes of commodification of the ‘commons’ are to be discussed and reflected on mutually and in an atmosphere of mutual freedom of articulation. But this disposition cannot and will not be found in a

situation, when the inherited and traditional authority of the “elephant” age group is confronted with some authority of the government in regional and national contexts.

The so-called “participatory” processes in the pastoralist communities does not only confront the people on the ground with readymade answers and new regulatory frameworks but excludes some members of the community completely from the wished for democratic process. They are put at risk. Thus, neither some “equal grounds of understanding” nor any “freedom to articulate one’s perceptions” and evaluations of the given social needs in terms of a fair and transparent handling of the new “structural forces” in the shape of the climate change imperative is sought for:

My neighbors in our settlement did not participate in the discussions. According to what I now know they are not happy with the decisions because they did not get any clarification on this matter like we did from the Woreda and the people from Addis. (Ariapa Lokitibo, man – 14 March 2015, approx. 38 years)

The example of the Nyangatom pastoralists in south Ethiopia unambiguously highlights given processes of communication to be by far not manifested in the open and freed from structural power. Communication in the committees is dominated by “experts,” that is, the agents of the government following the “development narrative” as outlined above. The actors on the ground resisted the officially outlined principles and practices of climate change adaptation “in the shadow”: “We should take disagreement to mean a determined kind of speech situation: one in which one of the interlocutors at once understands and does not understand what the other is saying. Disagreement is not the conflict between one who says white and the other says black. It is the conflict between one who says white and another who also says white but does not understand the same thing by it or does not understand that the other is saying the same thing in the name of whiteness” (Ranci re 1998).

Essentially, this argument proposes that governing climate change has been characterized not only by disagreement, but climate change communication in this case is to be understood as subcutaneous resistance, voiced quietly and under cover, stating in the end some ultimate failure in communication. With reference to the differences in an articulation of social justice as defined above the committees in today’s shape are not to be understood as windows of opportunity toward more environmental justice and sustainability in societal transformation. Mouffe (2013) links to the reflections of Ranci re (1998) and Swyngedouw (2011) referred to above, when she states: “We have to relinquish the claim that the processes of democratization should consist in the global implementation of the Western liberal democratic model . . . the kind of individualism dominant in Western societies is alien to many other cultures, whose traditions are informed by different values. Democracy, understood as ‘rule by the people’, can . . . take other forms – for instance, forms in which the value of community is more meaningful than the idea of individual liberty.”

The argument summarizes observations in the field accompanied and highlighted by the voices of the local agents stated above and objects to any claim of social justice granted to these agents, the pastoralists. The process of decentralization is not



to be taken as any granted path toward true communication with effective recognition of all community members on equalized grounds. Accordingly, the challenge to reach some just and in this way sustainable societal transformation is not responded to in any meaningful terms of governance.

---

### **Large-Scale Investment, Irrigation, and Villagization: Opening the “Ground” to the State – The Regional Scale**

Turning toward the regional scale, the argument links to the frequently quoted statement by the late Prime Minister of Ethiopia, Meles Zenawi, the sociopolitical meaning of which is to be considered one of the most crucial turning points toward the situation of societal transformation as of today: “I promise you that, even though this area is known as backward in terms of civilization, it will become an example of rapid development” (Meles Zenawi speaking at the Pastoral Day Festival in Jinka, South Omo Zone, 25 January 2011).

The first “state” representation in the Lower Omo Valley times back to the 1960s, when programs of sedentarization and the establishment of the Omo National Park (1966) and the Mago National Park (1979) led to increased resource pressure for the agro-pastoralist ethnic groups, traditionally inhabiting this area and using its resources for pastures for their livestock and especially the river banks for river retreat agriculture. Soon after, that is, in the 1980s, the then Ethiopian military regime released the Omo Basin Development Plan and in this context initiated the construction of the Gibe III hydro dam north of and at the entrance of the Lower Omo Valley, the construction of which was started in 2008 and the filling of which was completed in 2016. Today, the Gibe III dam is to be taken as the most influential structural incentive of those transformative forces and risks, which have defined and continue to define life and the livelihood systems in the Lower Omo Valley.

Relating to Meles Zenawi’s argument, commercial investment processes were predicted and initiated, which turned Ethiopia and especially the pastoralist lowlands of the country into a hotspot of what commonly is called the “land grab.” By emptying Ethiopia’s pastoral lowlands for large-scale investors, in the case of the Lower Omo Valley the Kuraz Sugar Development Project (KSDP), the ground was opened for police and military, for the “state,” giving protection to these investors. The establishment of the large-scale investment was sidelined and backed by the implementation of new agricultural technologies in settling and sedentarizing pastoralists in relocation sites by providing them with agricultural extension packages in terms of chemical fertilizer schemes, improved seeds, which the pastoralists had to pay for, and small parcels of irrigated land (Regessa et al. 2019). The government deliberately claimed the culturally inherited pastoralist land, the “commons,” for investments, as it was considered “underutilized” and “unproductive,” as the pastoralists were interpreted not “civilized” enough to make appropriate use of it. This villagization program, officially known as *Mender Masebaseb*, meant some fundamental transformation to the pastoralists – they were supposed to become and be

sedentary and give up or at least considerably reduce the basis of their livelihood system, their seasonal extensive cattle drives and migrations.

The Lower Omo Valley, South Omo, in historical times was and up to now is to be taken as an environment of latent and open social conflicts, conflicts on various levels and with reference to diverse agents and contesting parties. The 16 agropastoralist ethnic groups find themselves in partly violent competition on grazing grounds and heads of cattle. These conflicts have largely been analyzed by anthropologists like David Turton (1985) and Jon Abbink et al. (2014). Nowadays, since 2011, since the valley has turned into a region of high national interest, the local manifestation of the Government-owned Kuraz Sugar Development Project has opened new grounds for conflicts including human rights violations. About 90,000 people in the Lower Omo valley had been depending on flood-retreat farming for sorghum cultivation along the Omo (Turton 2010). In the more southerly parts of the Lower Omo the areas flooded by the river were larger, while the people on the surrounding plains were even more reliant on flood retreat farming than their neighbors in the north, as these practice rain-fed agriculture. Since the end of the Omo floods in 2015, most groups in the northern part of the Lower Omo Valley have become entirely dependent on rain-fed cultivation for crop-production, which leaves them highly vulnerable to climate change induced droughts, or solely dependent on corporation-controlled irrigation systems (Stevenson and Buffavand 2018). Furthermore, reductions in the river flows downstream of the sugarcane plantations are taken to reduce the availability of water – moisture in the soil – with damaging effects on the pastures for the pastoralists' livestock, especially cattle and sheep, while goats are browsers and can partly feed on bush vegetation. Land clearance for sugar plantations has additionally restricted wildlife in vital habitats and cut people's access to subsistence opportunities (Buffavand 2016).

KSDP operates on about 100,000 ha production sites of sugar cane, the formerly pastoralist "commons," irrigated by water from the Gibe III hydrodam. In conjunction with the dam, a system of canals has been built to distribute water to the Omo-Kuraz Plantation, within which selected plots of land have been assigned for use by "settler pastoralists" (Pictures I).

**Picture I** The example of one of the two irrigation canals along both sides of River Omo (source: with permission by Omo Turkana Research Network (OTuRN 2016)



At full capacity the Kuraz production sites would realize, this the initial projections, a quarter of Ethiopia's sugar and ethanol production, more than any other sugar production site in the country (ESC 2014). The sugar cane is, or will in near future be processed in up to five sugar factories lined along river Omo and situated in pastoralist territories. What is happening in the Lower Omo Valley combines elements of different types of displacement. The scheme was planned and executed by the current regime in Ethiopia in collaboration with an Italian engineering firm and international financiers. In 2012, the South Omo Zone Agriculture Bureau promoted a "Villagization Plan," which described how and when in the course of the coming year the people would be moved into new villages (FDRE 2012). In the plan the benefits of villagization are described as follows: "growing new crops, such as sugarcane on irrigated fields would improve food security; providing people with schooling and medical services would improve their health; settling in planned villages would reduce conflicts that result from "mobility in search of water and pasture". . . . "In the case of land that relies on rain (for cultivation) 2 hectares would be appointed to each settler pastoralist, whereas those settling on irrigable land would be appointed 0.5 hectares each" (FDRE 2012).

In contradiction to these positively connoted outlooks, findings from the field by E. G. J. Stevenson and L. Buffavand (2018) indicate that crop yields were and will be by far not sufficient to feed the pastoralist settlers, let alone to produce a surplus for sale. ". . . villagization was actually experienced by the Bodi settlers as undermining food security and diminishing well-being. It was experienced as heat, as disruption of routines, as a loss of control over livelihoods, as being treated like children rather than adults, and as abstracting work from ordinary sociality" (ibid). In congruence with these findings the study on "Social-ecological change in the Omo-Turkana basin: A synthesis of current developments" by almost the entire group of researchers active in the Omo-Turkana basin (Hobold et al. 2019) recapitulates their findings in a sense of comparative winners – the migrant laborers – and losers – the indigenous peoples (including both agro-pastoralists and pastoralists, but with more borne by agro-pastoralists currently): "Important SES-wide impacts will result from changes in regulating, provisioning, and cultural ecosystem services, including potential environmental degradation; loss of biological and cultural diversity; heightened competition and conflict over natural resources; and the potential for increased dependence on food aid" (ibid.). The other major actors – agro-industry investors, and the governments of Ethiopia and Kenya – they classify as in an equivocal position, with potential for large gains, but also exposure to substantial risks – a position, which is highly contradicted by one of the authors – Benedikt Kamski – at another place. In his argument titled "Omo investors won't scrub away Kuraz's sugary stain" (Kamski 2019) he states: "ESC (Ethiopian Sugar Corporation) rushed into the multi-billion dollar project, largely neglecting critical feasibility and impact assessments" (ibid). The author stresses the urge ESC is experiencing when the capital-intensive transformation of the region failed to bear fruit for its indigenous communities, which in turn creates new conflict dynamics. He concludes: "If economic interests alone guide investment decisions, official visions for inclusive pastoralist development – as recently reiterated by Deputy Prime Minister Demeke

Mekonnen – will require additional effort and financial commitment by the government, and a big question mark remains over whether this will materialize” (ibid.).

---

## **Climate Services, Pathways Toward Processes of Beneficial Societal Transformation? – The Local Scale**

As indicated above, the chapter will now and finally turn toward and highlight some projected initiative in terms of climate services towards a promotion of livelihood security and environmental justice in favor of the indigenous inhabitants of the Lower Omo Valley, the pastoralist societies. The reasoning of this perspective responds to the again and additionally outlined and named below livelihood risk and conflict scenarios taken to be highly virulent and tangible.

Upon the time and again scheduled and rescheduled completion of the Kuraz Sugar Development Project (KSDP) the overall about 800,000 ha pastoral land will be reduced by 100,000 ha. The sugar production was from the very beginning meant as vehicle of state governed development and progress. But, in spite of the major cutbacks in size and processing capacity, has the KSDP highly impacted on the livelihood system of the pastoralists (Kamski 2019; The Oakland Institute 2013). River Omo is nowadays framed by about 15-m broad irrigation canals, which hinder traditional use of water by the pastoralists for animals and river bench agricultural cultivation. As the pastoralists had to give way to the sugar plantations, they were called to re-settle in newly established permanent villages – the “villagization program” driven by Government policies. In the course of the thus induced transformation processes, many pastoral households are nowadays facing a livelihood situation of food-insecurity. In need of watering their livestock the pastoralist herders are nowadays forced to virtually beat their animals through a dark subway underneath the bottom of the irrigation canals, the so-called underfly. As the floor of these subways is moody and slippery, herders complain about injured cattle with broken legs. Lacking mostly veterinary services in the pastoral setting of life herders will eventually feel forced to kill their injured animal (Pictures I and II).

Additionally, and along with the establishment of the sugar plantations some extensive labor force was needed. Up to today, about 30,000 migrant laborers have arrived from the Ethiopian Highlands. Moreover, re-settlers from the highly populated areas of, for example, the Konso in South Ethiopia have taken advantage of the labor demand in the sugar project. The number of migrant laborers is expected to reach some hundreds of thousands, when all production sites and the five sugar factories will be fully operational (Kamski 2016).

Against the depicted situational setting, resource-based conflicts and at times violent encounters are and in future will be the “order of the day.” In the course of resource – land and water – scarcity, the agro-pastoralists ethnicities find themselves squeezed by natural factors (climate change) and the sugar cane development project. Hence, some growing resentment and animosity toward the dominance of the sugar project and some resistance against the migrant population are poisoning today’s encounters between the diverse interest groups. The pastoralists feel treated

**Picture II** One of the ‘underflies’, the only paths for the pastoralist herders to drive their livestock for watering (source: with permission by Omo Turkana Research Network (OTuRN 2016))



unjustly and surely suffer from a lack of recognitional as well as distributional justice.

Moreover, resource scarcity has increased the intensity and frequency of interethnic conflicts among the agro-pastoral ethnicities. If not solved, the current tensions and violent confrontations are likely to engulf the entire South Omo regional entity – one of Government’s perspective development corridors in Ethiopia.

In summary, food and livelihood security of the agro-pastoralists in the Lower Omo Valley have become highly vulnerable. This relates on the one hand to the considerable impact of climate change in the course of which the *Belg* Rains fail several seasons in succession as outlined above but likewise to the reduction of freely accessible pasture land in the course of the establishment of the sugar production sites and thus the reduced option in shifting cultivation in comparison to former times. The anchor element of this setting is “feed for the cattle,” the central economic and likewise sociocultural value in pastoralist livelihoods. With relation to this socioeconomic “anchor element” in question, the agricultural value chain of the produce sugar cane moves into focus. This value chain is centered to be the protagonist of conflict mediation and resolution in its function to smoothen livelihood stress and vulnerabilities. It is meant to be the manifestation of climate services applicable in given contexts.

In the course of the following argument some design shaping a rather realistic feature of climate services was outlined in 2019, but seemingly has not been realized up to now. As pointed out above the following discussion will in consequence be somehow speculative – but all the same realistic. The envisioned scheme of climate services targets the given lay of conflicts between the indigenous pastoralist communities and the Ethiopian Sugar Corporation (ESC) by one central element: by cut-off residues, bagasse, and molasses from the sugar cane, by-products from the sugar production – to be turned into cattle feed. A project like this would be conceptualized as “contract research,” with high emphasis on the value chain development of the sugar cane, but likewise with explicit focus on various social perspectives on conflict

resolution, discharging into a process of integrative societal transformation (Picture III).

Guided by the promoted Government politics in terms of “ethnic reconciliation” the project could operate on value chain development and open access to cattle feed for the pastoralist ethnicities. New environments of coexistence among the interest groups in question on equalized grounds were to be defined and processes of integrative societal transformation to be eased.

It can be foreseen that climate services as outlined above bear dangers in terms of some processes of fatal societal transformation, as will be outlined as follows: Indigenous pastoralist societal organization does by its concepts of live and livelihood constituents not incorporate the idea of feeding and, even much less, fattening cattle, whereas the government program of villagization claims the idea of sedentism of the pastoralists in South Omo, which necessarily implies the need for some ways and means of stationary sources of income for the then non-migratory population. In consequence enforced societal transformation will demand considerable conceptual architecture and research endeavor in order to accompany and facilitate these pathways into newly to be designed livelihood systems and outcomes. But, this

**Picture III** A herder with his favorite ox (source: with permission by Julia Pfitzner)



should be noted: these at first sight completely new and seemingly culturally non-acceptable pathways are not to be taken as any purely unrealistic illusion! Already ten years ago and in the face of the above illustrated severe climate change induced droughts, had Nyangatom cattle herders started to sell cattle – at that time under disguise and hidden away from their fathers and elders (Troeger et al. 2012). Very obviously, processes of societal transformation were on the way – already at the beginning of the decade, to be enforced and accelerated by today’s bundle of urges. Already at that time some members of the pastoral communities, especially the young men and women, were ready for processes of societal transformation. They were for example ready to abandon their culturally manifested and strict rule to not slaughter cattle except for religious reasons. The perspective of cattle feed would newly and additionally demand some readiness for societal transformation on the side of the pastoralists. The pastoralist cultural setting does by traditionally fixed rules not allow for any sale and ownership in capitalist terms, which would necessarily be one of the terms of sale and storage of cattle feed. – And at this point the question whether the climate service initiative in the outlined way would do good or harm must stay unanswered.

---

## Conclusion

Concluding and turning back to the initially highlighted challenge envisioning societal transformation in terms of environmental justice realized with and for the inhabitants of the Lower Omo Valley in Ethiopia the chapter summarizes the argument in succession of the four environmental scales of analysis.

Very obviously do the forces on the global scale, the climate change imperative, threaten the livelihood system of pastoralism and the individual inhabitants of the pastoral lowlands in a way, which does not open any window of chance for a positive change. The pastoralists cannot but react on this threat by leaving the area with the cattle herd for seasons in succession with almost no way of return. In consequence of the given risky environment the people abandon their culturally inherited customs like the “culture of sharing” and try to survive as individual households and families, which is to be taken as a, if not fatal then at least highly damaging and un-just momentum of societal transformation.

The offer or challenge of decentralization and handing societal concerns, that is, governance, over to the people on the ground in the shape of committees does not offer any true chance of sustainable transformation. As the “state” governed committees do not open any room for recognitional and likewise procedural justice, and do neither acknowledge preexisting governance arrangements as well as world-views, knowledges, or cultures nor safeguard feasible and acceptable ways of participation and decision making, these two dimensions of justice in societal transformation are not realized in any operational way. The process is to be taken as unsustainable.

Human rights focused critics of the Omo-Gibe basin, namely the Oakland Institute (2013), describe the effects of the upstream hydropower reservoir Gibe III

and the land clearing for the Kuraz Sugar Development Project, that is, the forces at the regional scale, as a tragedy that has caused hunger and conflict. Again, and with relation to these forces, no justice in terms of recognition and installment procedures was and is granted to the people, the pastoralists on the ground, and as well constellations at this scale are to be taken as unsustainable.

Finally, the local scale in vision, the chapter turns against a too euphoric interpretation of the perspective of “transformations” in terms of climate services. Cattle feed from the residues of the sugar cane might offer some chance, maybe the only chance, for some partial loss compensation. But surely the more substantive aspects of a sustainable, which means a just handling of given situational settings, would need attention in the face of the claim for environmental and social justice:

- Which distributional effects will societal transformations have within the pastoralist societies? Who of the members of the pastoralist communities will be in the lead and govern the processes of feed storage, distribution and sale, and how will these subsequent leading social positions be legitimized?
- How will questions of societal justice, participation, and the distributive effects of climate change be addressed in social debates?
- Which changes in modes of governance and participation could be essential for any promising transformative processes?

---

## References

- Abbinck J et al (2014) Lands of the future: transforming pastoral lands and livelihoods in eastern Africa. Working paper N0. 154. Max Planck Institute, Halle
- Adger N, Paavola J, Huq S, Mace M (2006) Fairness in adaptation to climate change. MIT Press, Cambridge
- Adger N et al (2009) Are there social limits to adaptation to climate change? *Clim Chang* 93:335–354
- Appadurai A (1990) Disjuncture and difference in the global cultural economy. *Theory Cult Soc* 7(2–3):295–310
- Ayele Z (2011) Local government in Ethiopia: still an apparatus of control? *Law Democr Dev* 15(1):1–27
- Buffavand L (2016) ‘The land does not like them’: contesting dispossession in cosmological terms in Mela, South-West Ethiopia. *J East Afr Stud* 10(3):476–493
- ESC (Ethiopian Sugar Corporation) (2014) Vision, Mission, Values. <http://www.etsugar.gov.et/php/en/about/vision-mission-values>
- European Commission (2014) [www.climate-services.org/about-us/what-are-climate-services](http://www.climate-services.org/about-us/what-are-climate-services)
- Famine Early Warning Systems Network: <https://fews.net/east-africa/ethiopia>
- FDRE (2012) South Omo Villagization plan. Federal Democratic Republic of Ethiopia, Addis Ababa
- Foucault M (1977) *Dispositive der Macht. Über Sexualität, Wissen und Wahrheit*. Merve-Verlag, Berlin
- Hobold J et al (2019) Social-ecological change in the Omo-Turkana basin: a synthesis of current developments. Springer, without pages
- Kamski B (2016) The Kuraz Sugar Project (KSDP) in Ethiopia: between ‘sweet visions’ and mounting challenges. *J East Afr Stud* 10(3):568–580



- Kamski B (2019) Ethiopia Insight: Omo investors won't scrub away Kuraz's sugary stain. <https://www.ethiopia-insight.com/2019/08/01>
- Lefort R (2012) Free market economy, 'developmental state' and party state hegemony in Ethiopia: the case of the 'model farmers'. *Afr Stud* 50(4):681–706
- Mouffe C (2013) *Agonistics: thinking the world politically*. Verso, London/New York
- Mueller-Mahn D, Everts J, Stephan Ch (2018) Riskscape revisited – exploring the relationship between risk, space and practice. *Erdkunde* 72:197–213
- Omo Turkana Research Network OTuRN (2016) Briefing note I – The Kuraz Sugar Development Project, Michigan State University, 1–6
- Rancière J (1998) *Disagreement: politics and philosophy*. University of Minnesota Press, Minneapolis
- Regessa A, Hiziekil Y, Korf B (2019) 'Civilizing' the pastoral frontier: land grabbing, dispossession and coercive agrarian development in Ethiopia, University of Zurich
- Schatzki T (2002) *The site of the social: a philosophical account of the constitution of social life and change*. The Pennsylvania State University Press, University Park
- Schatzki T (2012) A primer on practices. In: Higgs J, Barnett R, Billet S, Hutchings M, Trede F (eds) *Practice-based education: perspectives and strategies*. Sense Publishers, Rotterdam, pp 13–26
- Stevenson EG, Buffavand L (2018) 'Do our bodies know their ways?' – Villagization, food-insecurity, and ill-being in Ethiopia's Lower Omo Valley. *Afr Stud Rev* 61:109–133
- Swyngedouw E (2011) Interrogating post-democratization: reclaiming egalitarian political spaces. *Polit Geogr* 30(7):370–380
- Temper L, Walter M, Rodriguez I, Kothari A, Turhan E (2018) A perspective on radical transformations to sustainability: resistances, movements and alternatives. *Sustain Sci* 13:747–764
- The Oakland Institute (2013) *OMO: local tribes under threat, a field report from the Omo Valley, Ethiopia*. Oakland
- Troeger S (2016a) Societal transformation, buzzy perspectives towards successful climate change adaptation: an appeal to caution, Chapter 19. In: Filho WL et al (eds) *Handbook of climate change adaptation. Climate change management – implementing climate change adaptation in cities and communities, integrating strategies and educational approaches*. Climate change management series. Springer, Cham, pp 353–365
- Troeger S (2016b & 2018) 'Everything that is happening now is beyond our capacity' – Nyangatom livelihoods under threat, Chapter 19. In: Filho WL et al (eds) *Climate change management series*. Springer, pp 353–365. Republished in Cambridge University Press & UNESCO: *Indigenous knowledge for climate change assessment and adaptation*, Chapter 15. Cambridge, pp 214–226
- Troeger S (2018) 'Committees', a promising institution in climate change communication and adaptation? Chapter 22. In: Leal W et al (eds) *Handbook of climate change communication. Climate change management, vol 2*. Springer, Cham, pp 341–355
- Troeger S et al (2012) *Failing seasons, ailing societies – climate change and adaptation in Ethiopia*. Addis Ababa
- Turton D (1985) Mursi response to drought: some lessons for relief and rehabilitation. *Afr Aff* 84 (336):331–346
- Turton D (2010) The downstream impact. Presentation at the School of Oriental and African Studies, University of London, organized by the Royal Africa Society. [www.mursi.org](http://www.mursi.org) [www.climate-services.org/about-us/what-are-climate-services](http://www.climate-services.org/about-us/what-are-climate-services)

**Open Access** This chapter is licensed under the terms of the Creative Commons Attribution 4.0 International License (<http://creativecommons.org/licenses/by/4.0/>), which permits use, sharing, adaptation, distribution and reproduction in any medium or format, as long as you give appropriate credit to the original author(s) and the source, provide a link to the Creative Commons license and indicate if changes were made.

The images or other third party material in this chapter are included in the chapter's Creative Commons license, unless indicated otherwise in a credit line to the material. If material is not included in the chapter's Creative Commons license and your intended use is not permitted by statutory regulation or exceeds the permitted use, you will need to obtain permission directly from the copyright holder.





# Impacts of Global Warming on West African Monsoon Rainfall

# 119

Imoleayo E. Gbode, Vincent O. Ajayi, Kehinde O. Ogunjobi, Jimy Dudhia, and Changhai Liu

## Contents

Introduction .....	2471
Model Domain, Data, and Methods .....	2472
Model Domain and Numerical Experiment Setup .....	2472
Datasets .....	2474
Results and Discussion .....	2475
Temperature Characteristics .....	2475
Precipitation Characteristics .....	2477
Conclusion .....	2481
References .....	2482

This chapter was previously published non-open access with exclusive rights reserved by the Publisher. It has been changed retrospectively to open access under a CC BY 4.0 license and the copyright holder is “The Author(s)”. For further details, please see the license information at the end of the chapter.

I. E. Gbode (✉)

West African Science Service Center on Climate Change and Adapted Land Use,  
Federal University of Technology, Akure, Ondo State, Nigeria

Mesoscale and Microscale Meteorology Laboratory, National Center for Atmospheric Research,  
Foothills Laboratory, Boulder, CO, USA

e-mail: [iegbode@futa.edu.ng](mailto:iegbode@futa.edu.ng)

V. O. Ajayi

West African Science Service Center on Climate Change and Adapted Land Use,  
Federal University of Technology, Akure, Ondo State, Nigeria

e-mail: [voajayi@futa.edu.ng](mailto:voajayi@futa.edu.ng)

K. O. Ogunjobi

Department of Meteorology and Climate Sciences, West African Science Service Centre on Climate  
Change and Adapted Land Use (WASCAL), Federal University of Technology Akure (FUTA),  
Ondo State, Nigeria

Federal University of Technology Akure (FUTA), Ondo State, Nigeria

e-mail: [ogunjobi.k@wascal.org](mailto:ogunjobi.k@wascal.org)

© The Author(s) 2021

W. Leal Filho et al. (eds.), *African Handbook of Climate Change Adaptation*,  
[https://doi.org/10.1007/978-3-030-45106-6\\_93](https://doi.org/10.1007/978-3-030-45106-6_93)

2469

---

**Abstract**

The impacts of global warming on rainfall in West Africa were examined using a numerical framework for 5 monsoon years (2001, 2007, 2008, 2010, and 2011). Rainfall characteristics over the three climatic zones, Guinea coast, Savannah, and Sahel, were analyzed. The potential changes associated with global warming were assessed by the pseudo-global warming (PGW) downscaling method. Multiple PGW runs were conducted using climate perturbation from the 40-member ensemble of the Community Earth System Model version 1 (CESM1) coupled with Community Atmospheric Model version 5.2 (CAM5.2) component large ensemble project. The model output was compared with Tropical Rainfall Measuring Mission and Global Precipitation Climatology Project rainfall alongside surface temperature from the European Center for Medium-Range Weather Forecast Reanalysis. Results show that the estimated rainfall amount from the future climate in the 2070s increases slightly compared with the current climate. The total rainfall amount simulated for the current climate is 16% and 63% less than that of the PGW runs and observations, respectively. Also found is an increase (decrease) in heavy (light and moderate) rainfall amount in the PGW runs. These results are, however, contingent on the global circulation model (GCM), which provides the boundary conditions of the regional climate model. CESM1.0-CAM5.2, the GCM employed in this study, tends to provide a greater surface temperature change of about 4 °C. This projected temperature change consequently caused the increase in the simulated precipitation in the PGW experiments, thus highlighting the advantage of using the PGW method to estimate the likely difference between the present and future climate with reduced large-scale model differences and computational resources. The findings of this study are, however, useful to inform decision-making in climate-related activities and guide the design of climate change adaptation projects for the West African region.

---

**Keywords**

Rainfall · Temperature · Pseudo-global warming · Guinea coast · Savannah · Sahel · Weather Research and Forecasting model · Community Earth System Model

---

J. Dudhia

Mesoscale and Microscale Meteorology Laboratory, National Center for Atmospheric Research, Foothills Laboratory, Boulder, CO, USA  
e-mail: [dudhia@ucar.edu](mailto:dudhia@ucar.edu)

C. Liu

Research Applications Laboratory, National Center for Atmospheric Research, Foothills Laboratory, Boulder, CO, USA  
e-mail: [chliu@ucar.edu](mailto:chliu@ucar.edu)

## Introduction

West African monsoon (WAM) prevails during the West African rainy season and provides a large amount of rainfall, over 75% (Hagos and Cook 2007), in most parts of the region. Activities of the WAM vary across intraseasonal, interseasonal, and interannual time scale. This temporal variability is expected to intensify as a result of human-induced climate change which can thereafter cause serious consequences for health and human well-being, agriculture and food security, as well as water resources and hydrological cycles (Houghton et al. 2001; IPCC 2018).

Scientific researches have made tremendous efforts to improve the understanding of climate change and its causes, and these efforts are being advanced further to better understand the current and future potential impacts (CNR 2010; IPCC 2018). Climate models have proved useful to assess the current state of the climate and to project future climate conditions under various scenarios (NOAA 2019). Fully coupled global circulation models (GCMs) are useful tools for performing global simulations. These state-of-the-art models can be employed to investigate climate change associated with increase in greenhouse gas concentrations caused by anthropogenic activities. However, the coarse nature of GCM's horizontal resolution limits their ability to reproduce local climates, which are directly related to the inability of the model to properly resolve orographic features (IPCC 2007). Other methods such as statistical downscaling (Schmidli et al. 2006), dynamical downscaling (CORDEX, Giorgi et al. 2009), and direct simulation by high-resolution GCM (Wild et al. 1995) are gaining more application to project climate conditions at a regional scale. Therefore, to better represent climate phenomena of interest, in our case the West African monsoon, extremely high horizontal resolution is required. For example, a grid point interval of less than several kilometers or rather at a convection-permitting scale, usually less than 4 km (Prein et al. 2013), is more appropriate for simulating the complex interactions related to orography and local climate, which directly impact the monsoon system of the region.

Because the monsoon rainfall can vary at different time scales, long-term dynamical downscaling, such as the CORDEX, or ensemble projects are necessary to determine the impacts of global warming on the monsoon variability. Long-term simulations at several tens of kilometers or even convection-permitting grid is, however, rather difficult to obtain because of insufficient computational resources and high cost of the use of available resources. Considering the current constraint, to avoid huge computations as regards simulating a longer year-to-year variability, short period numerical experiments are done using the pseudo-global warming method.

The pseudo-global warming (PGW) approach (Liu et al. 2017) is a dynamic downscaling method that permits regional climate change projections with the use of a regional climate model. The PGW method employs initial and lateral boundary conditions that combine 6-hourly reanalysis data and the climate change signals, which are the monthly averaged differences between the current and future climate projections produced by a GCM. The method expects the boundary condition mean state to have similar climatology to those of the GCM future climate projections, but the daily evolution is similar to that of current years. The PGW technique provides the

possibility of having a direct comparison between the present year and the PGW year in the context of the interannual variation with the addition of future climatology.

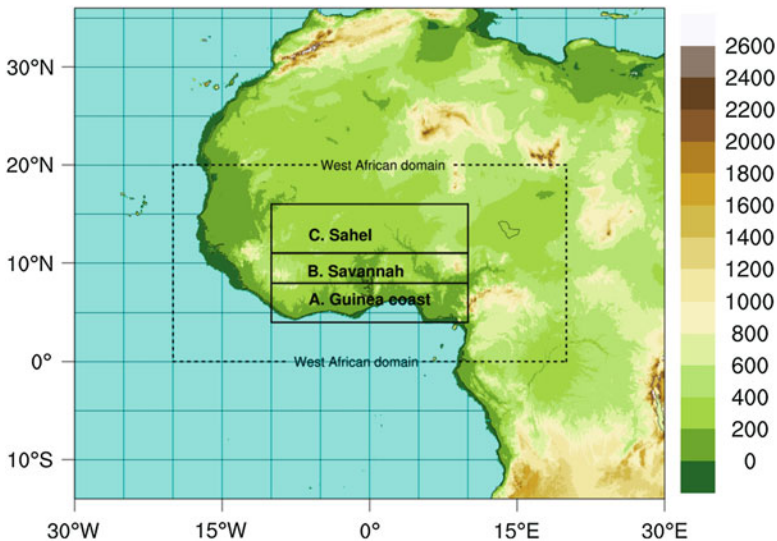
The objective of this research is to investigate the impacts of global warming on rainfall in West Africa during the monsoon period. We employed the PGW method to directly compare future rainfall amount with that of the current. The remaining part of the study is structured as follows: section “[Model Domain, Data, and Methods](#)” describes the study area and numerical experiment setup as well as the observation and reanalysis data used. Results and discussion are presented in section “[Results and Discussion](#)” and the conclusion is drawn in section “[Conclusion](#).”

## Model Domain, Data, and Methods

### Model Domain and Numerical Experiment Setup

The WRF model version 3.8.1 model is used to perform the regional climate simulations over a 20-km horizontal resolution and 50 model levels. Similar to the studies of Gbode et al. (2019a, b), the domain covers the West African region ( $0^{\circ}$ – $20^{\circ}$  N,  $20^{\circ}$  W– $20^{\circ}$  E; see Fig. 1), including parts of the Atlantic Ocean, that provides the most moisture carried into the region by the low-level monsoon flow.

Five years were selectively simulated and analyzed to account for interannual variability. The considered years represent wet (2008 and 2010), dry (2001 and 2011), and normal (2007) WAM years. The characteristics of the chosen years are determined by the departure of the total annual rainfall amount from long-term mean total annual rainfall over the entire West African domain (not shown for brevity).



**Fig. 1** WRF model domain showing elevation in meters and highlights of the West African ( $0^{\circ}$ – $20^{\circ}$  N,  $20^{\circ}$  W– $20^{\circ}$  E) region and the three climatic zones: (a) Guinea coast, (b) Savannah, and (c) Sahel. (Source: Gbode et al. 2019b)

The numerical study includes three experiments each for current climate and PGW simulations. These experiments combine different WRF model physics: two microphysics (MP), Goddard (GD) and Weather Research and Forecasting (WRF) model single-moment 5-class (WSM5); three planetary boundary layers (PBL), Mellor-Yamada-Janjić (MYJ), Mellor-Yamada-Nakanishi-Niino (MYNN) Level 2.5, and Yonsei University (YSU); and three cumulus convection (CU), Bet-Miller-Janjić (BMJ), new Tiedtke (nTDK), and new simplified Arakawa Schubert (nSAS) parameterization schemes. The choice of the selected combinations is based on results from a preliminary study (Gbode et al. 2019a).

The first experiment was a retrospective simulation aimed at reproducing the variability and mean state of the current climate within the model domain of ~20 km. The simulation contains the selected years, each extending from February to December, but the period March 1 to October 31 was analyzed. The present climate runs are hindcast runs driven by 6-hourly ERA-Interim (ERA-Interim, Dee et al. 2011) atmospheric data with soil (moisture and temperature) initialization from the National Centers for Environmental Prediction Final Reanalysis (NCEP-FNL 2000) (Eq. 1). The NCEP FNL soil data was used to be consistent with the unified Noah land surface model, which was kept constant, as described in Gbode et al. (2019a).

$$WRF_{\text{Input1}} = ERA_{\text{Interim}}_{\text{Atmosphere}} + FNL_{\text{Soil}} \quad (1)$$

The second simulation closely follows the pseudo-global warming (PGW) approach used in previous studies (e.g., Liu et al. 2017). Though the approach doesn't account for extreme events, it, however, allows direct comparison between the current and future climate. The simulations of each of the selected years were forced with ERA-Interim, FNL reanalysis, plus climate perturbation (see Eq. 2) derived from the Community Earth System Model version 1 (CESMv1) with the Community Atmospheric Model version 5.2 (CAMv5.2) of the Large Ensemble Community Project (LENS) (Kay et al. 2015):

$$WRF_{\text{Input2}} = ERA_{\text{Interim}}_{\text{Atmosphere}} + FNL_{\text{Soil}} + \overline{\Delta CESM1\_CAM5.2_{RCP8.5}}^{\text{monthly}} \quad (2)$$

where  $\overline{\Delta CESM1\_CAM5.2_{RCP8.5}}^{\text{monthly}}$  (see Eq. 3) is the monthly 30-year LENS 40-member ensemble-mean change signal of the business as usual representative concentration pathway (RCP8.5), a comparatively high greenhouse gas emission pathway (Riahi et al. 2011):

$$\overline{\Delta CESM1\_CAM5.2_{RCP8.5}}^{\text{monthly}} = \frac{\overline{CESM1\_CAM5.2_{2071-2100}}}{\overline{CESM1\_CAM5.2_{1976-2005}}} \quad (3)$$

The perturbed physical fields include horizontal wind, temperature, and relative humidity. First, the climate change signals are obtained at monthly average resolution, and then these are interpolated to analysis times and the model grid

**Table 1** Model greenhouse gas concentration to reflect the midyear value of the current (1976–2005) and future (2071–2100) simulations (IPCC 2007, 2014)

Greenhouse gas	Current	Future (RCP8.5)
Carbon dioxide (CO <sub>2</sub> )	379 ppmv	801 ppmv
Methane (CH <sub>4</sub> )	1774 ppbv	3564 ppbv
Nitrous oxide (N <sub>2</sub> O)	319 ppbv	414 ppbv
Chlorofluorocarbons-11 (CFC-11)	251 ppt	86 ppt
Chlorofluorocarbons-12 (CFC-12)	538 ppt	211 ppt

when adding them to the analyses. The LENS CESMv1-CAMv5.2 is approximately 1° latitude/longitude with CAMv5.2 as its atmospheric component. CESMv1-CAMv5.2 is a 40-member ensemble of the LENS of fully coupled CESMv1 simulations for the current (historical) and future (RCP8.5) periods 1976–2005 and 2071–2100, respectively. Each member is subjected to the same radiative forcing scenario but begins from a slightly different initial atmospheric state created by randomly perturbing temperatures at the level of round-off error (Kay et al. 2015). The ensemble average is used to remove interannual variability from the climate change signal.

Before running the PGW simulations, the WRF model was recompiled to reflect the expected mean greenhouse gas concentration levels of the midyear of the last climate epoch of the twenty-first century (i.e., 2086) for the representative concentration pathway 8.5 (see Table 1; IPCC 2007, 2014). RCP8.5, a greenhouse gas concentration (not emissions) trajectory, is one of the four RCPs IPCC adopted in its fifth Assessment Report (AR5). The RCP 8.5 is categorized based on possible radiative forcing value of 8.5 W/m<sup>2</sup>, which assumes that emissions will continue to rise throughout the twenty-first century (Meinshausen et al. 2011).

## Datasets

The absence of a richly dense network of conventional rain gauges and synoptic weather stations limits the model validation to satellite rainfall products (SRPs) and reanalysis datasets. For rainfall, Tropical Rainfall Measuring Mission (TRMM) (Huffman et al. 2007) and GPCP (Huffman et al. 2016) are used. Though the satellite-derived rainfall contains differences consequent to their observation platforms and different algorithms used in producing them, they, however, conserve the mean rainfall features (Sylla et al. 2013). The Global Precipitation Climatology Project 1° Daily (GPCP 1dd) is a reliable SRP produced from optimized merged estimates computed from microwave, infrared, and sounder data observed by the international constellation of precipitation-related satellites and precipitation gauge analysis (Huffman et al. 2016). Also, the daily TRMM 3B42 version 7 is another reliable source for merged high-quality precipitation estimates (Huffman et al. 2007). The model rainfall is compared with both GPCP and TRMM and its surface air temperature against reanalysis data from the European Center for Medium-Range Weather Forecast Reanalysis (ERA1).



## Results and Discussion

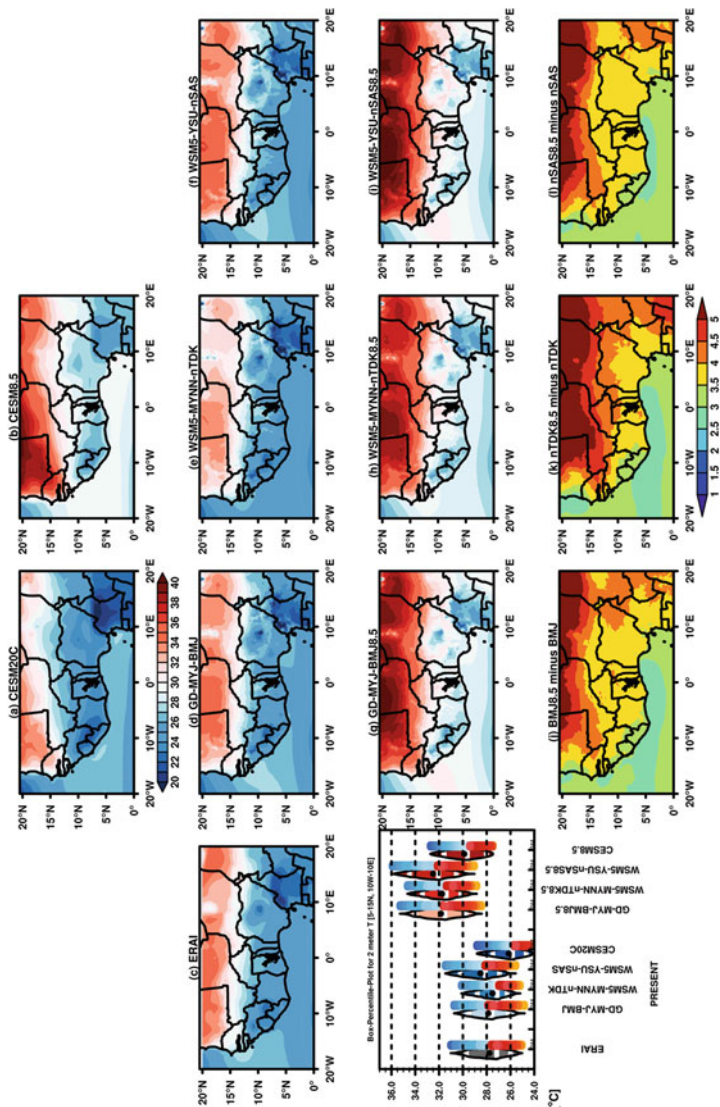
### Temperature Characteristics

Figure 2 shows the mean surface air temperature averaged during the period JJAS for ERAI reanalysis and model outputs (i.e., present and future runs). In this panel, Fig. 2a, b shows the current and future runs from CESM, Fig. 2c depicts ERAI, Fig. 2d, f shows the present climate runs, Fig. 2g, i shows the PGW runs, and Fig. 2j, l depicts the difference between PGW and present climate during JJAS. The boxplot below Fig. 2c shows the statistics of the 2-meter temperature from March to October over the area within latitudes 5–15°N and longitudes 10°W–10°E.

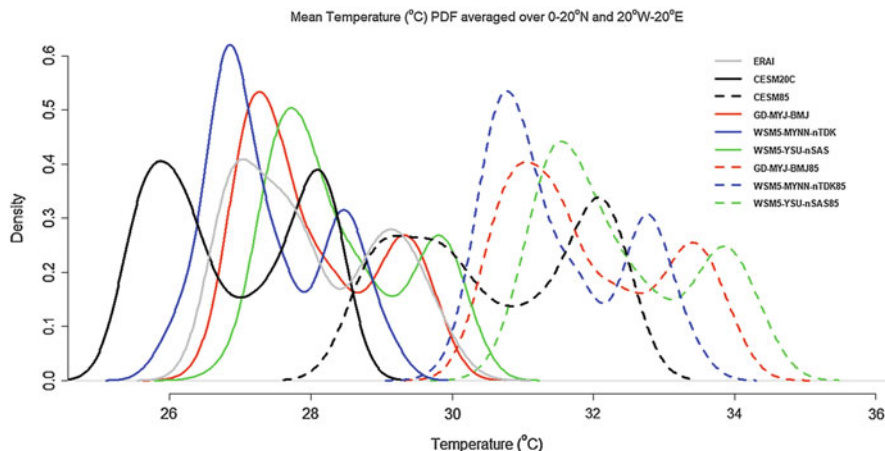
The reanalysis shows observed temperature range between 20 °C and 36 °C with a steep gradient in the Sahel. This gradient is associated with the Saharan heat low defined by the mean position of the intertropical discontinuity (ITD) and low-pressure center, mostly in August when the monsoon is fully developed (Nicholson 2013). Also, surface air temperature over complex orographic terrains is cooler relative to the desert and nearby land areas. During the twentieth century (Fig. 2a), CESM simulates similar distribution as observed but cooler temperatures over complex terrains, mostly over the Cameroon Mountains and Fouta Djallon highlands. In the future runs (Fig. 2b), the model simulates warmer conditions over the complex terrains and even higher temperatures of about 40 °C over the Sahel. The present runs from the WRF model (Fig. 2d, f) also agree with the reanalyzed temperature gradient but with some biases mostly in the Sahara desert region. Simulated air temperature in the PGW runs, generally, shows warming across the entire domain and ocean (Fig. 2g–i). The maximum value exceeds 40 °C over the desert area. Relative to the present climate, the PGW runs are 5 °C warmer. In GD-MYJ-BMJ8.5 and WSM5-YSU-nSAS8.5, there is a uniform warming of 4 °C from the coast upward to about 15°N latitude followed by a northward steep gradient. A similar warming pattern is found in WSM5-MYNN-nTDK8.5 but restricted only to about 10°N. Over the ocean, the magnitude of warming is lesser perhaps due to its high heat retention capacity.

The box-percentile plot below Fig. 2c presents the distribution of temperature values during the period March to October for the area enclosed within latitudes 5°–15°N and longitudes 10°W–10°E. The values of ERAI range between 25° C and 31 °C with the mean being 27.9 °C. The distribution of the current climate simulation ranges from 24 °C to 31.5 °C. Relative to the WRF simulations, CESM simulates lower temperatures during the current and future runs. Results of the PGW runs show a wider range of temperature (28–36 °C) and a significant shift in the mean. The average difference in the mean between the PGW and current is approximately 4 °C. The warming is generally found in all three simulations.

Further analysis of the probability distribution shows that the surface air temperature averaged over 0–20°N and 20°W–20°E varies from 24 °C to 31 °C and from 27 °C to 35.3 °C for the current and future climate, respectively, with two density maxima that are related to stronger peaks in some months (Fig. 3). These density maxima could be associated with pre-monsoon, when the temperatures are



**Fig. 2** Average surface air temperature during the period JJAS for ERAI reanalysis and model outputs (i.e., present and future runs). Panels (a) and (b) show the current (twentieth century) and future (2071–2100) runs from CESM, (c) depicts ERAI, (d–f) show the present climate runs, (g–i) show the PGW runs, and (j–l) depict the difference between PGW and present climate during JJAS. The boxplot below c shows the statistics of the 2-m temperature from March to October over the area within latitudes 5–15°N and longitudes 10°W–10°E. Values in the WRF model plots are averages derived from the selected five years (i.e., 2001, 2007, 2008, 2010, and 2011)

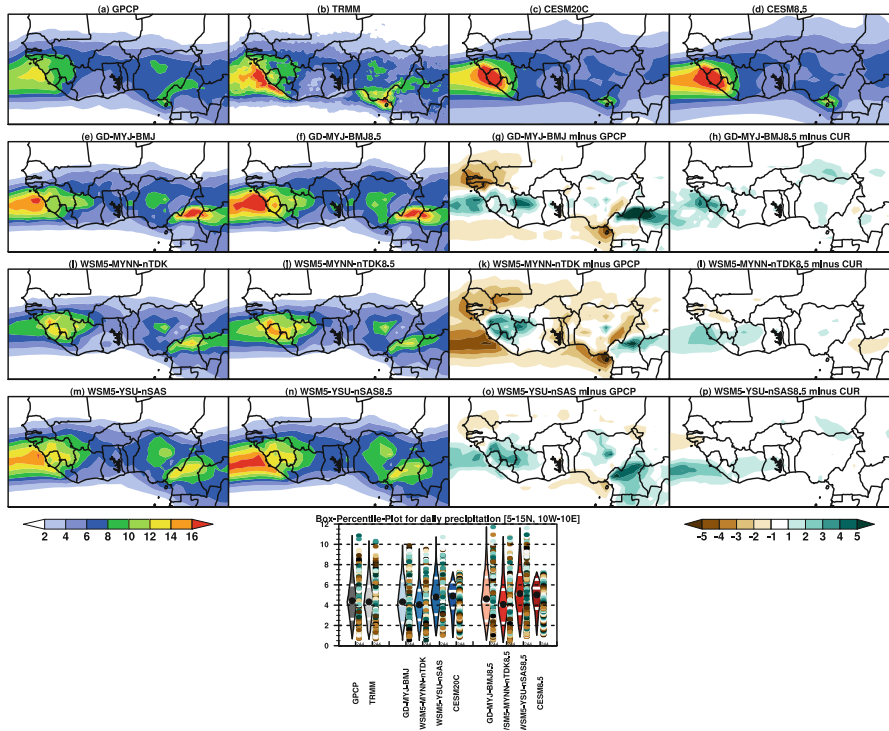


**Fig. 3** Probability density function of observed and simulated daily mean temperature averaged over 0–20°N and 20°W–20°E domain. ERAI and WRF outputs are derived from the average of the selected five years, while CESM20C and CESM85 are derived for the period 1976–2005 (continuous lines) and 2071–2100 (dash lines), respectively

usually high as a result of clear sky conditions that allow more insolation to reach the surface, and post-monsoon periods, when the temperatures are usually low as a result of frequent convective activities that bring about cloudy conditions which prevent incoming radiation from reaching the surface. The observed density (gray line, i.e., ERAI) corresponding to the low (high) temperature maxima is higher (lower). CEMS simulates lower temperatures compared with ERAI and WRF current and PGW runs. This underscores the benefit of having a high-resolution regional climate simulation. The three model experiments also reproduced the observed distribution with varying densities. For example, the density of low temperature values in WSM5-MYNN-nTDK is higher compared with that of GD-MYJ-BMJ and WSM5-YSU-nSAS. During the last climate regime of the twenty-first century (2071–2100), both GCM and RCMs simulate a significant increase in temperature. Temperatures in the WRF runs are expected to increase more compared with the GCM. The upper bound shift in temperature could reach 3–4 °C.

### Precipitation Characteristics

The observed average daily precipitation amount and the modeled values for present and future simulations during the period June–September (JJAS) are presented in Fig. 4. Also, the bottom boxplot of Fig. 4 shows the statistics of the daily precipitation distribution from March to October over the area bounded by latitudes 5–15°N and longitudes 10°W–10°E. GPCP and TRMM (in Fig. 4a, b) show average daily rainfall values reaching 14 and 16 mm day<sup>-1</sup>, respectively. Both observed products agree in terms of producing maximum values over complex orographic terrains and



**Fig. 4** Spatial distribution of average daily rainfall ( $\text{mm day}^{-1}$ ) for the period JJAS. Values of (a) GPCP, (b) TRMM, and (e, f, i, j, m, and n) WRF runs are derived from the average of the five simulated years, while (c and d) CESM values are derived from the considered 30-year current and future periods. Differences between (g, k, and o) GPCP and WRF current and (h, l, and p) PGW and current runs are also presented in the figure. The bottom boxplot shows the statistics of the daily precipitation distribution from March to October over the area of latitudes  $5\text{--}15^\circ\text{N}$  and longitudes  $10^\circ\text{W}\text{--}10^\circ\text{E}$

minimum in other land areas. CESM simulates values of  $16 \text{ mm day}^{-1}$  in the twentieth century and RCP8.5 (Fig. 4c, d) in agreement with TRMM, but the GCM, however, shows deficiencies in reproducing the observed maximum over complex terrains of Jos Plateau and the southeast orientation pattern over the Cameroon Mountains; this points out the limitations of the GCM to reproduce certain features due to its coarse horizontal resolution that makes it difficult to properly capture atmospheric phenomena at smaller horizontal scales than its grid.

Consistent in observations and WRF simulations is the band of maximum daily average rainfall sitting, on average, along latitude  $10^\circ\text{N}$ . Also, the RCM runs agree with observations as they simulate the climatological precipitation maxima over complex orographic terrains of Cameroon Mountains, Jos Plateau, and Fouta Djallon highlands with extension toward the western coast of West Africa. In the present year simulations, GD-MYJ-BMJ also reproduces the magnitude of  $16 \text{ mm day}^{-1}$  over the Cameroon Mountain and the west coast of the monsoon region (Fig. 4e). For

WSM5-MYNN-nTDK and WSM5-YSU-nSAS (Fig. 4i, m) runs, the simulated magnitude could be  $15 \text{ mm day}^{-1}$  or less. The PGW runs show an increase in daily precipitation relative to the present climate runs, most especially over complex orographic terrains and over the west coast of West Africa. While the simulated values of GD-MYJ-BMJ8.5 and WSM5-YSU-nSAS8.5 could be greater than  $17 \text{ mm day}^{-1}$ , that of WSM5-MYNN-nTDK8.5 only simulates maximum of  $15 \text{ mm day}^{-1}$  (Fig. 4f, j, and n).

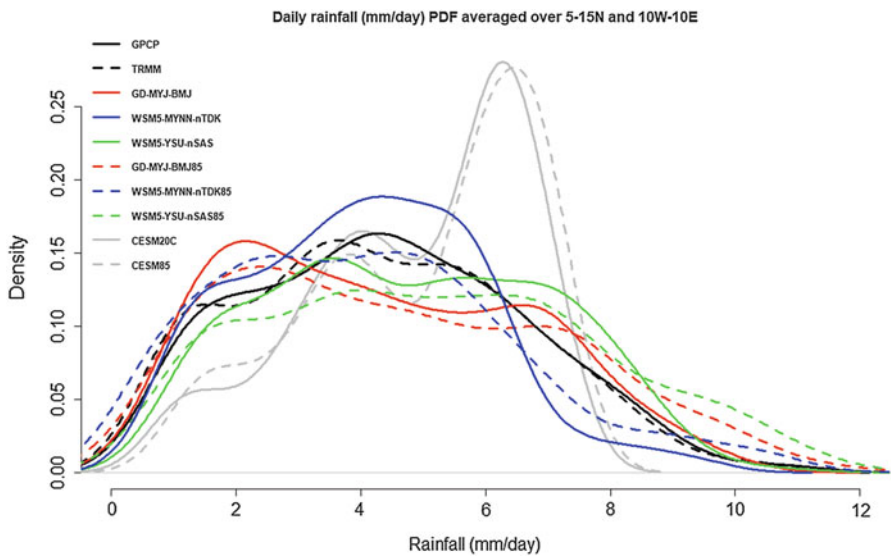
Although the models agree with the observation patterns, there exist some systematic errors. The degree of these errors is quantitatively assessed, firstly, by taking the difference between current runs and GPCP (Fig. 4g, k, and o). The results show wetness of about  $5 \text{ mm day}^{-1}$  over complex terrain and other land areas. In contrast, dryness (less than  $-5 \text{ mm day}^{-1}$ ) is simulated over the western Sahel and along the southern coast of the monsoon region as well as ocean areas. Secondly, the degree of error is quantitatively assessed by computing the difference between PGW and current climate runs which shows general wetness of less than  $4 \text{ mm day}^{-1}$  around the western part of the region and small extent of  $2 \text{ mm day}^{-1}$  dryness in other land areas (Fig. 4h, l, and p). Further, to examine the effect of warming on precipitation, the statistics of observations and model results are presented at the bottom of Fig. 4 (boxplot). Results show that the maximum observed and modeled daily precipitation in the considered area ( $5^{\circ}$ – $15^{\circ}$ N and  $10^{\circ}$ W– $10^{\circ}$ E) is about 11 and  $12 \text{ mm day}^{-1}$  for PGW runs. In CESM, the values are less than  $8 \text{ mm day}^{-1}$ . The mean value for GPCP and TRMM is slightly above  $4 \text{ mm day}^{-1}$ . For the current climate runs, GD-MYJ-BMJ agrees with the observed mean values, while WSM5-MYNN-nTDK simulates exactly  $4 \text{ mm day}^{-1}$ . WSM5-YSU-nSAS produces higher magnitudes of daily precipitation and an increase in the mean (i.e.,  $5 \text{ mm day}^{-1}$ ). The impacts of warming are evident through an increase in the mean and maximum value of PGW runs. This response is most obvious in GD-MYJ-BMJ8.5 and WSM5-YSU-nSAS8.5, where there is a slight increase in the mean ( $\sim 0.2 \text{ mm day}^{-1}$ ) and maximum daily rainfall ( $>12 \text{ mm day}^{-1}$ ). In WSM5-MYNN-nTDK, there is an increase in the maximum daily precipitation values but no significant change in the mean distribution.

The precipitation changes (shown in Fig. 2) between GPCP and current runs are averagely found to be  $-5$ ,  $0.6$ , and  $-50\%$  in the Guinea coast, Savannah, and Sahel, respectively. Also, differences between TRMM and current runs may reach maximum values of  $-19$ ,  $-7$ , and  $-52\%$  for the corresponding climatic zones. Some of the models underestimate the observed average daily rainfall, mostly in TRMM. Between the current and PGW runs, the average percentage difference is generally small and ranges between  $-2\%$  and  $16\%$  over the entire monsoon region. In general, the average percentage difference is greater mostly in the Sahel. This suggests the possibility of experiencing greater impacts on rainfall regimes in the Sahel as a result of global warming. Relative to Sahel, a less impact is felt in the Guinea coast, where there are heterogeneous surfaces and features, and a mild influence in Savannah (Table 2).

Furthermore, the probability distribution analysis of the average daily rainfall amount reveals varying densities over the  $5$ – $15^{\circ}$ N latitudes and  $10^{\circ}$ W– $10^{\circ}$ E

**Table 2** Average percentage difference (%) of total rainfall amount observed and modeled during the period March to October for the five years over each climatic zone. GPCP and TRMM (upper row) are subtracted from the current model runs (lower rows) to compute the percentage difference. In the same manner, the current runs are subtracted from the PGW runs

Climatic zone	GPCP			TRMM			PRESENT		
	BMJ	nTDK	nSAS	BMJ	nTDK	nSAS	BMJ8.5	nTDK8.5	nSAS8.5
<b>Guinea coast</b>	-12	-10	7	-3	-18	-19	3	-1	8
<b>Savannah</b>	1	-6	7	-3	-6	-12	3	4	6
<b>Sahel</b>	-47	-59	-45	-50	-44	-63	16	-2	9



**Fig. 5** Probability density function of observed and simulated daily mean rainfall averaged over the 5–15°N and 10°W–10°E domain. GPCP, TRMM, and WRF outputs are derived from the average of the selected five years, while CESM20C and CESM85 are derived for the periods 1976–2005 and 2071–2100, respectively

longitudes (as shown in Fig. 5). The rainfall distribution between GPCP and TRMM is similar with little differences. Both the current and future climate runs of CESM possess a high density of rainfall of about 6 mm day<sup>-1</sup>. Also, a slight rainfall increase of greater than 6 mm day<sup>-1</sup> is simulated in CESM future runs relative to the current runs. Whereas values of less than 6 mm day<sup>-1</sup>, however, occur more in the GCM’s current runs. The distribution in the WRF simulations is similar to that of the observations, thus highlighting the benefit of having high-resolution regional climate simulations. Generally, the WRF model simulates occurrences of increased heavy and light rainfall in the PGW runs. Also, the PGW run simulates lesser frequencies of moderate rains. WSM5-YSU-nSAS PGW runs simulate higher average daily rainfall intensity relative to WSM5-MYNN-nTDK and GD-MYJ-BMJ,

respectively. This combination, however, simulates lower densities of moderate average daily rainfall.

To further investigate the characteristics of daily rainfall over the region, the rainfall is disintegrated into different categories, light ( $1\text{--}2\text{ mm day}^{-1}$ ), moderate ( $\geq 2\text{--}10\text{ mm day}^{-1}$ ), and heavy ( $\geq 10\text{ mm day}^{-1}$ ), based on the probability density function presented in Fig. 5. Rainfall between 1 and 2 mm provides percentage of rainfall within the range of 7.7–8.7% for the period March to October (not shown for brevity) and decreases by 0.8–1% in the RCM. Category of rainfall within 2–10 mm provides 54–67% of rainfall and shows not only a decrease in the frequency of rains but also a decrease in the percentage (i.e., 3–6%) in the future. Heavy rainfall (i.e. 10 mm and above) contributes between 24–31.4% and 30–37.9% rainfall amount in the current and future climate, respectively, in WRF simulations. This type of rainfall is expected to increase by 3–6.5% in the future. For CESM, the percentage of 42.2% and 49.4% is simulated in the current and future climate, respectively. The GCM simulates this feature only in the complex terrain of Cameroon Mountains and the west coast of the monsoon region.

Though the results of this study are based on the GCM, which provides the boundary conditions for the RCM, it provides useful insights to inform decision-making in climate-related sectors of the economy such as agriculture, water resources, hydropower generation, and other climate-dependent activities. Likewise, the findings are useful to guide the design of climate change adaptation projects that will ensure a climate-resilient and sustainable development. The PGW approach used, however, doesn't account for extreme events. Hence, the need for longer-term simulations in future studies to assess extreme events and their associated impacts.

---

## Conclusion

This study examined the impacts of global warming on precipitation amount during the West African monsoon season using the PGW method. Three experiments that combine microphysics, convection, and planetary boundary layer parameterization schemes were also conducted for both current and PGW climate runs. Model runs were performed for selected wet (2008–2010), dry (2001–2011), and normal (2007) monsoon years in the region at 20-km horizontal resolution. Also, the precipitation characteristics over the three climatic zones; Guinea coast, Savannah, and Sahel, were analyzed. The current and PGW climate runs showed good agreement with the observed precipitation by reproducing the spatial distribution pattern over complex orographic terrains. The estimated rainfall amount in the 2070s from the PGW runs increased slightly compared with the current climate runs. In all climatic zones, the total precipitation amount simulated by the current climate is less than 16% and 63% relative to the PGW runs and the observations, respectively. However, the difference between current climate runs and observations is higher relative to that of PGW runs. GD-MYJ-BMJ runs have good agreement with observations in terms of simulating the characteristics of wet, dry, and normal monsoon years, which is defined by total precipitation amount. WSM5-MYNN-nTDK is more consistent in defining the

precipitation characteristic in Savannah and Sahel, while WSM5-YSU-nSAS rarely agrees in any two of the climatic zones. Also found is an increase in heavy rainfall amount and a decrease in both light and moderate rainfall amount.

Though the results of this study are based on the GCM, which provides the boundary conditions for the RCM, it provides useful insights to guide policymakers to make informed decisions on issues concerning climate-related sectors of the economy such as agriculture, water resources, hydropower generation, and other climate-dependent activities. Besides, the findings are useful to guide the design of climate change adaptation projects that will ensure a climate-resilient and sustainable development. The PGW approach used, however, doesn't account for extreme events, hence, the need for longer simulations in future studies.

**Acknowledgments** The German Federal Ministry of Education and Research (BMBF) primarily funded this research through the Doctoral Research Programme-West African Climate System (DRP-WACS) hosted at the Federal University of Technology Akure (FUTA), Ondo State, Nigeria. Many thanks to NCAR's MMM Laboratory for supporting the research work. We would like to acknowledge highperformance computing support from Cheyenne (<https://doi.org/10.5065/D6RX99HX>) provided by NCAR's Computational and Information Systems Laboratory, sponsored by the National Science Foundation.

---

## References

- Council National Research (2010) Advancing the science of climate change. The National Academies Press, Washington, DC. <https://doi.org/10.17226/12782>
- Dee DP, Uppala SM, Simmons AJ, Berrisford P, Poli P, Kobayashi S et al (2011) The ERA-interim reanalysis: configuration and performance of the data assimilation system. *Q J R Meteorol Soc* 137:553–597. <https://doi.org/10.1002/qj.828>
- Gbode IE, Dudhia J, Ogunjobi KO, Ajayi VO (2019a) Sensitivity of different physics schemes in the WRF model during a West African monsoon regime. *Theor Appl Climatol* 136(1–2):733–751. <https://doi.org/10.1007/s00704-018-2538-x>
- Gbode IE, Ogunjobi KO, Dudhia J, Ajayi VO (2019b) Simulation of wet and dry West African monsoon rainfall seasons using the Weather Research and Forecasting model. *Theor Appl Climatol* 1–16. <https://doi.org/10.1007/s00704-019-02912-x>
- Giorgi F, Jones C, Asrar GR (2009) Addressing climate information needs at the regional level: the CORDEX framework. *Bull World Meteorol Organ* 58(3):175–183
- Hagos SM, Cook KH (2007) Dynamics of the West African monsoon jump. *J Clim* 20(21):5264–5284. <https://doi.org/10.1175/2007JCLI1533.1>
- Houghton JT, Ding Y, Griggs DJ, Noguer M, van der Linden PJ, Dai X, Maskell K, Johnson C (2001) Climate change 2001: the scientific basis, 881. <https://doi.org/10.1256/004316502320517344>
- Huffman GJ, Bolvin DT, Adler RF (2016) GPCP version 1.2 one-degree daily precipitation data set. Research data archive at the National Center for Atmospheric Research, Computational And Information Systems Laboratory. <https://doi.org/10.5065/D6D50K46>
- Huffman GJ, Bolvin DT, Nelkin EJ, Wolff DB, Adler RF, Gu G et al (2007) The TRMM Multisatellite Precipitation Analysis (TMPA): quasi-global, multiyear, combined-sensor precipitation estimates at fine scales. *J Hydrometeorol* 8(1):38–55. <https://doi.org/10.1175/jhm560.1>
- Intergovernmental Panel on Climate Change (IPCC) (2007). Climate change 2007 – the physical science basis: working group I contribution to the fourth assessment report of the IPCC. Science, (October 2009), 1009. <https://doi.org/volume>



- Intergovernmental Panel on Climate Change (IPCC) (2014) Climate change 2014: synthesis report. Contribution of Working Groups I, II and III to the fifth assessment report edited by Team CW, Pachauri RK, Meyer LA. Geneva, 151
- Hoegh-Guldberg O, Jacob D, Bindi M, Brown S, Camilloni I, Diedhiou A, Hijioka Y (2018) Impacts of 1.5 °C global warming on natural and human systems. Global warming of 1.5 °C. An IPCC Special Report
- Kay JE, Deser C, Phillips A, Mai A, Hannay C, Strand G, . . . Vertenstein M (2015) The community earth system model (CESM) large ensemble project: a community resource for studying climate change in the presence of internal climate variability. *Bull Am Meteorol Soc* 96(8):1333–1349. <https://doi.org/10.1175/BAMS-D-13-00255.1>
- Liu C, Ikeda K, Rasmussen R, Barlage M, Newman AJ, Prein AF, . . . Yates D (2017) Continental-scale convection-permitting modeling of the current and future climate of North America. *Clim Dyn* 49(1–2):71–95. <https://doi.org/10.1007/s00382-016-3327-9>
- Meinshausen M, Smith SJ, Calvin K, Daniel JS, Kainuma MLT, Lamarque J, . . . van Vuuren DPP (2011). The RCP greenhouse gas concentrations and their extensions from 1765 to 2300. *Clim Change* 109(1–2):213. <https://doi.org/10.1007/s10584-011-0156-z>
- National Oceanic and Atmospheric Administration (NOAA) (2019) Climate models. Retrieved September 7, 2019, from <https://www.climate.gov/maps-data/primer/climate-models>; website: <https://www.climate.gov/maps-data/primer/climate-models>
- NCEP-FNL (2000) National Centers for Environmental Prediction/National Weather Service/NOAA/U.S. Department of Commerce (2000) updated daily. NCEP FNL Operational Model Global Tropospheric Analyses, continuing from July 1999. Research Data Archive at the National Center
- Nicholson SE (2013) The West African Sahel: A review of recent studies on the rainfall regime and its interannual variability. *ISRN Meteorology* 2013
- Prein AF, Gobiet A, Suklitsch M, Truhetz H, Awan NK, Keuler K, Georgievski G (2013) Added value of convection permitting seasonal simulations. *Clim Dyn* 41:2655–2677. <https://doi.org/10.1007/s00382-013-1744-6>
- Riahi K, Rao S, Krey V, Cho C, Chirkov V, Fischer G et al (2011) RCP 8.5-a scenario of comparatively high greenhouse gas emissions. *Clim Change* 109(1–2):33. <https://doi.org/10.1007/s10584-011-0149-y>
- Schmidli J, Frei C, Vidale PL (2006) Downscaling from GCM precipitation: a benchmark for dynamical and statistical downscaling methods. *Int J Climatol* 26(5):679–689. <https://doi.org/10.1002/joc.1287>
- Sylla MB, Giorgi F, Coppola E, Mariotti L (2013) Uncertainties in daily rainfall over Africa: assessment of gridded observation products and evaluation of a regional climate model simulation. *Int J Climatol* 33(7):1805–1817. <https://doi.org/10.1002/joc.3551>
- Wild M, Ohmura A, Gilgen H, Roeckner E (1995) Regional climate simulation with a high resolution GCM: surface radiative fluxes. *Clim Dyn* 11(8):469–486. <https://doi.org/10.1007/BF00207196>

**Open Access** This chapter is licensed under the terms of the Creative Commons Attribution 4.0 International License (<http://creativecommons.org/licenses/by/4.0/>), which permits use, sharing, adaptation, distribution and reproduction in any medium or format, as long as you give appropriate credit to the original author(s) and the source, provide a link to the Creative Commons license and indicate if changes were made.

The images or other third party material in this chapter are included in the chapter's Creative Commons license, unless indicated otherwise in a credit line to the material. If material is not included in the chapter's Creative Commons license and your intended use is not permitted by statutory regulation or exceeds the permitted use, you will need to obtain permission directly from the copyright holder.





# Transformative Adaptations for Health Impacts of Climate Change in Burkina Faso and Kenya

# 120

Edmund Yeboah, Aditi Bunker, Peter Dambach, Isabel Mank, Raïssa Sorgho, Ali Sié, Stephen Munga, Till Bärnighausen, and Ina Danquah

## Contents

Introduction: Proposed Adaptation Strategies for Climate Change Impacts in Two Exemplar Regions of Sub-Saharan Africa .....	2486
Strategy 1: Agro-Biodiversification and Nutrition Intervention in Rural Burkina Faso and Rural Kenya .....	2488
Background .....	2488
Procedures .....	2490

This chapter was previously published non-open access with exclusive rights reserved by the Publisher. It has been changed retrospectively to open access under a CC BY 4.0 license and the copyright holder is “The Author(s)”. For further details, please see the license information at the end of the chapter.

E. Yeboah · A. Bunker · P. Dambach · I. Mank · R. Sorgho  
Heidelberg Institute of Global Health (HIGH), Heidelberg University, Heidelberg, Germany  
e-mail: [edmund.yeboah@uni-heidelberg.de](mailto:edmund.yeboah@uni-heidelberg.de); [aditi.bunker@uni-heidelberg.de](mailto:aditi.bunker@uni-heidelberg.de); [isabel.mank@uni-heidelberg.de](mailto:isabel.mank@uni-heidelberg.de); [raissa.sorgho@uni-heidelberg.de](mailto:raissa.sorgho@uni-heidelberg.de)

A. Sié  
Centre de Recherche en Santé de Nouna (CRSN), Nouna, Burkina Faso

S. Munga  
Centre for Global Health Research (CGHR) at the Kenya Medical Research Institute (KEMRI), Kisumu, Kenya

T. Bärnighausen  
Heidelberg Institute of Global Health (HIGH), Heidelberg University, Heidelberg, Germany  
Department of Global Health and Population, Harvard T. H. Chan School of Public Health, Boston, MA, USA

Africa Health Research Institute (AHRI), Durban/Mtubatuba, South Africa  
e-mail: [till.baernighausen@uni-heidelberg.de](mailto:till.baernighausen@uni-heidelberg.de)

I. Danquah (✉)  
Heidelberg Institute of Global Health (HIGH), Heidelberg University, Heidelberg, Germany  
German Institute of Human Nutrition Potsdam-Rehbruecke (DIfE), Nuthetal, Germany  
e-mail: [ina.danquah@uni-heidelberg.de](mailto:ina.danquah@uni-heidelberg.de)

Strategy 2: Cool Roofs to Improve Human Health, Environmental and Economic Outcomes in Rural Burkina Faso .....	2491
Background .....	2491
Procedures .....	2493
Strategy 3: Index-Based Weather Insurance in Rural Burkina Faso .....	2493
Background .....	2493
Procedures .....	2494
Strategy 4: Larviciding Against Malaria Vectors in Rural Burkina Faso .....	2495
Background .....	2495
Procedures .....	2496
Conclusions .....	2497
References .....	2497

## Abstract

Climate change strongly affects the health of sub-Saharan African populations. Effective adaptation strategies are required in order to enhance their limited adaptive capacities. The DFG-funded Research Unit (RU) “Climate change and health in sub-Saharan Africa” unites nine research institutions from Burkina Faso, Kenya, Germany, and Switzerland that will design, implement, and evaluate four different adaptation projects in these two African countries from 2020 until 2022.

First, the effectiveness of an agro-biodiversification and nutrition program will be established for the reduction of child undernutrition of climate-sensitive nutrients in rural Burkina Faso and Kenya. Two respective cluster-randomized controlled trials (cRCT) will be conducted, each consisting of  $2 \times 600$  children. Second, another cRCT will be conducted among  $2 \times 300$  households in rural Burkina Faso to investigate how sunlight-reflecting cool-roof coatings affect human health outcomes, including cardiovascular and heat-related outcomes. Further outcomes comprise indoor temperature, carbon footprint, and productivity. Third, an index-based weather insurance (IBWI) will be introduced in rural Burkina Faso. The effects of IBWI on childhood nutritional status, dietary behavior, and healthcare seeking will be determined in  $2 \times 20$  villages. Fourth, microbial larviciding has been evaluated as a promising environmental control for malaria vectors in Burkina Faso. Here, the interactions between climatic factors and the effectiveness of the intervention will be tested using spatiotemporal models.

## Keywords

Climate change · Sub-Saharan Africa · Adaptations · Undernutrition · Heat-stress · Malaria

## Introduction: Proposed Adaptation Strategies for Climate Change Impacts in Two Exemplar Regions of Sub-Saharan Africa

Climate change constitutes one of the biggest threats and opportunities to global health (Costello et al. 2009; Watts et al. 2015). The World Health Organization (WHO) estimates that between 2030 and 2050, climate change will cause

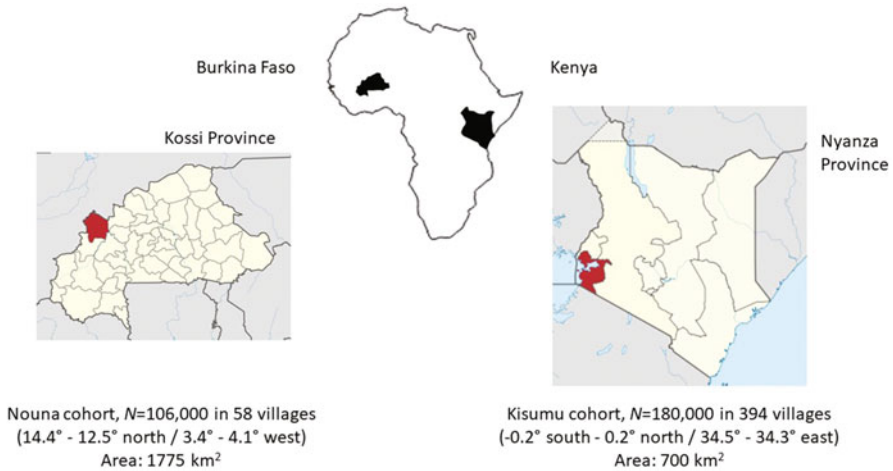
approximately 250,000 additional deaths/year, with an increasing trend (WHO 2014). Indeed, global warming, weather instability, and weather extremes have emerged as major risk factors for global health acting on their own or modifying the effect of the wide array of the immediate and intermediate determinants of health. The recent report by the International Panel on Climate Change (IPCC) has concluded that climate change is expected to exacerbate a wide range of health problems, including undernutrition, vector-borne diseases, and noncommunicable diseases (IPCC 2017; Woodward et al. 2014). The report further points to the heat-mediated productivity losses, not least in agricultural production in low-income settings (Kjellstrom et al. 2017). While the causes, impacts, and mitigation efforts of climate change truly act globally, efficient and effective adaptation strategies require local solutions. This is particularly true for sub-Saharan Africa, where climate change impacts on health are felt strongest because the populations there exhibit the least adaptive capacity.

Autonomous and planned adaptations will be necessary to meet the challenges of common smallholder subsistence systems in sub-Saharan Africa (IAASTD 2009). Small-scale subsistence farmers are defined as rural households with agricultural-based access (max. 2 ha) to essential resources for survival (Grace et al. 2012). Proposed adaptation strategies generally refer to risk management or production enhancement, and include:

- Altering the timing or the location of cropping activities and the diversification of agriculture (Constanzo and Bàrberi 2013)
- Increasing the access to financial and technological resources that facilitate adaptation to climate change (Bizikova et al. 2009)
- Risk protection by index-based weather insurance (IBWI) as one option of market-based risk management mechanisms (Leblois and Quirion 2013)
- Novel methods of vector control to overcome drug resistance, changes in vector-biting behavior, and altered vector species (Tusting et al. 2013)

Herein, four specific adaptation strategies are described that will be designed, implemented, and evaluated over the next 3 years (2020–2022) within the framework of the Research Unit (RU) “Climate Change and Health in sub-Saharan Africa,” funded by the German Research Foundation (DFG). The RU builds on previous collaborations and existing research infrastructure within the Health and Demographic Surveillance Systems (HDSS) in Nouna (Burkina Faso) and Kisumu (Kenya). The locations and the characteristics of the two HDSS sites are presented in Fig. 1 and Table 1, respectively.

According to the gross domestic product (GDP) per capita, Burkina Faso is one of the poorest countries in the world, whereas Kenya ranks among the lower-middle-income countries (World Bank 2018). The HDSS sites Nouna and Kisumu have been established in the early 1990s; the Kisumu area is more densely populated than the Nouna site. Climate-wise, these two HDSS locations differ: Nouna experiences one rainy season per year with excessive rainfalls in August and high temperatures during the dry season; Kisumu has two rainy seasons and experiences lower



**Fig. 1** The Health and Demographic Surveillance sites in Burkina Faso and Kenya

temperatures in the highlands. The inhabitants of both regions live on small-scale subsistence farming, which is complemented by fishing in the Kenyan areas close to Lake Victoria. The typical diets in both regions are based on starchy staples and legumes. According to the Living Standards Measurement Study (LSMS) by the World Bank, the share of livelihoods from subsistence farming in both areas ranges between 70% and 90% (World Bank 2017). The proportion of children with acute and chronic undernutrition tends to be higher in Kisumu than in Nouna. Both areas are holo-endemic for malaria transmission with similar prevalence among children. HIV incidence in Kisumu is three-times higher than in Nouna.

## Strategy 1: Agro-Biodiversification and Nutrition Intervention in Rural Burkina Faso and Rural Kenya

### Background

Climate change impacts food security through direct and indirect pathways (Myers et al. 2017), and presumably affects the spread of malaria in sub-Saharan Africa (Caminade et al. 2014; Dasgupta 2018). Increased greenhouse gas emissions, particularly CO<sub>2</sub>, reduce the contents of iron, zinc, and protein in major staple foods in this region (Myers et al. 2014; Smith and Myers 2018). This development will likely slow down the reduction of macro- and micronutrient undernutrition in the most vulnerable population group of children aged <5 years and their mothers (Smith and Myers 2018). As an integral part of a food-systems approach, agricultural bio-diversification seems to be a promising tool to achieve resilience against increased atmospheric CO<sub>2</sub>, improved dietary diversity, and thus, adequate micronutrient supplies and protein utilization (Constanzo and Bärberi 2013; Olney et al. 2015). Still, the success of

**Table 1** Characteristics of the Nouna and the Kisumu Health and Demographic Surveillance (HDSS) areas

Characteristics	Nouna, Burkina Faso	Kisumu, Kenya
National GDP per capita in 2017	670 US\$	1508 US\$
Health care facilities	1 district hospital with surgical unit, 13 basic health facilities	36 health facilities: 1 district hospital, 2 private hospitals, 11 health centers, and 22 dispensaries
Geographic position	North-west (Boucle de Mouhoun)	West (Nyanza Province)
	Land-locked	Partly located at Lake Victoria
	Rural and semi-urban	Rural
Surveillance area	1775 km <sup>2</sup>	700 km <sup>2</sup>
Altitude	260 m above sea level	1070 m above sea level
Population under surveillance	115,000 individuals	220,000 individuals
	14,548 households	54,869 households
	58 villages	385 villages
Starting of HDSS	1992	1990
Age structure of HDSS	17% <5 years of age	13% <5 years of age
Weather/ climate	Rainy season: June till October	Long rains: March till May
	Mean annual rainfall: 800 mm	Short rains: October till December
	Daily min T: 20–28 °C	Mean annual rainfall: 1200–1500 mm
	Daily max T: 29–37 °C	T between 17 °C and 35 °C
Major crops in subsistence agriculture	Millet, sorghum, maize, peanuts, rice, and sesame	Maize, beans, sweet potatoes, sorghum, rice, cassava
Nutritional status of children <5 years	21% stunting	30% stunting
	14% underweight	20% underweight
	10% wasting	6% wasting
	~80% anemia	~50% anemia
Malaria in children <5 years	Malaria is hyper- to holoendemic, peaking at the end of the rainy season	Malaria is holoendemic with transmission throughout the year
	Prevalence: 30–50%	Prevalence: 30–50%
HIV/AIDS	HIV rate: 0.26/1000 pyrs	HIV rate: 3.09/1000 pyrs
	Prevention of Mother-To-Child Transmission (PMTCT) according to WHO guidelines (coverage 50–80%)	PMTCT using Nevirapine, Lamivudine, Zidovudine

such adaptation strategies depends on the local food supply chains (Sibhatu et al. 2015) and remains to be established for sub-Saharan Africa. In addition, a healthy nutritional status through agricultural bio-diversification may also reduce the risk of clinical malaria among young children living in endemic regions (Danquah et al. 2009). Yet, expanding the agricultural land cover bears the adverse potential of

generating breeding sites for malaria vectors, thereby fueling parasite transmission (Janko et al. 2018).

This project addresses the potential of a household, agricultural bio-diversification, and nutrition program to improve the nutritional status and to reduce episodes of clinical malaria among young children and their mothers living in two subsistence and malaria-endemic areas of rural sub-Saharan Africa. The specific research objectives are:

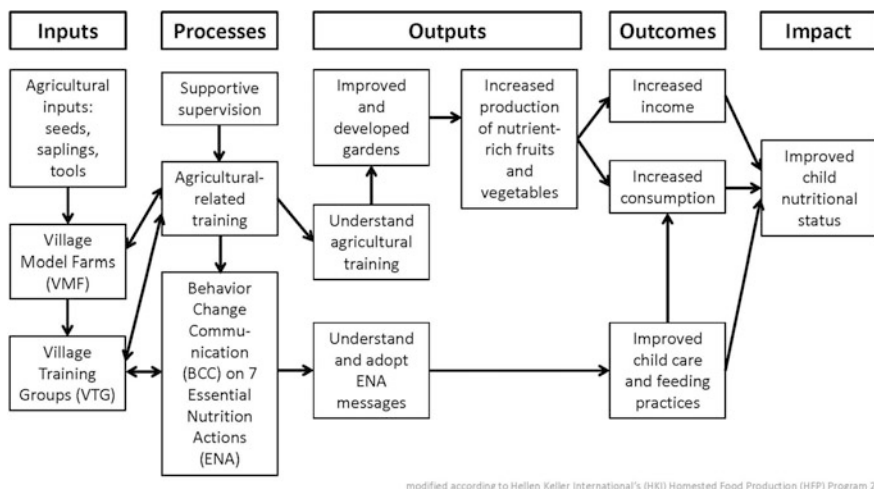
- (i) To establish the baseline cross-sectional associations of self-sufficient food supply and dietary habits with the status of climate-sensitive nutrients (protein, iron, zinc) among children at the age of supplementary feed introduction (6–24 months) and their mothers in rural Burkina Faso and rural Kenya.
- (ii) To establish the effects of the agricultural bio-diversification and nutrition program on dietary habits, anthropometric measures of protein-energy under-nutrition, micronutrient status, and the risk of clinical malaria among young children and their mothers.
- (iii) To quantify the relative contributions of additional household greenspace and improved childhood nutritional status through this agricultural and nutrition intervention to malaria risk in children.

## Procedures

This project will start in January 2020 and involves the scientific evaluation of an integrated agriculture and nutrition program focusing on agricultural bio-diversification to improve the status of climate-sensitive nutrients among children aged 6–59 months. For this purpose, this study will adopt a program that was successfully implemented and evaluated in other parts of rural Burkina Faso (Olney et al. 2015). The conceptual framework of this intervention program relies on three impact pathways that are depicted in Fig. 2:

- Increased production of climate-resilient horticultural crops and diversification of crops for increased consumption of these foods.
- Increased output of foods to increase income.
- Increased knowledge related to the importance of agricultural diversification (= use more indigenous plants) for the resilience of local crops and thus, food and nutrient security for healthy families, thereby increasing the adoption of optimal practices.

More specifically, the study will conduct two cluster-randomized controlled trials (cRCT), enrolling 600 households at each site with children at the age of supplementary feed introduction (6–24 months) at baseline. These households will be randomized to the control group or the intervention group. The intervention will comprise an agriculture component and a nutrition part. The agriculture component will foster agro-diversification using horticultural crops in home gardens, based on



**Fig. 2** Impact pathways of the integrated agricultural bio-diversification and nutrition program, modified according to Hellen Keller International's Homestead Food Production Program 2013

village model gardens and specific trainings. The nutrition component comprises regular sessions on Behavior Change Communication focusing on the seven Essential Nutrition Action (ENA) messages by the World Health Organization. After an observation period of at least 12 months, height-for-age z-scores among the enrolled children (30–48 months) will be assessed as the primary nutrition and health-outcome. Secondary outcomes include weight-for-age z-score, weight-for-height z-score, iron and zinc status, incl. hemoglobin concentrations (Hb), species richness in home gardens, dietary behavior, and associated costs. The data will be analyzed on an intention-to-treat basis by random effects linear models and accounting for the cluster design. The formative research of this project has started in September 2019; the recruitment of households with young children is envisioned for the middle of 2020; and follow-up shall be completed in the first quarter of 2023.

## Strategy 2: Cool Roofs to Improve Human Health, Environmental and Economic Outcomes in Rural Burkina Faso

### Background

Increasing mean global temperature and extreme heat are adversely affecting people's health. Projections show that warming of 4 °C in 2100 relative to preindustrial levels in sub-Saharan Africa will result in an increase of monthly summer temperatures by 4–6 °C above present-day temperatures (Schellnhuber and Hare 2013). Even if warming is limited to within 2 °C by 2050, adaptation costs in Africa are expected to rise to USD 35 billion/year, while warming in the range of 3.5–4 °C, as projected under current emissions, will elevate adaptation costs dramatically to USD



50 billion/year (AMCEN, UNEP, and Climate Analytics 2013). These costs highlight the need for early action.

Millions of homes in resource-poor countries are built with low-cost materials, such as corrugated metal roofing sheets, that expose occupants to high temperatures. Owing to their high expense and electricity use, technologies such as air conditioners are ill-suited in resource-poor settings to alleviate the discomfort from heat. In sub-Saharan Africa, where climate change effects on health and well-being are most severe, adaptive technologies do not yet meet the needs of populations to ease the burden from heat.

Advances in housing technologies can passively reduce indoor temperatures through increased solar reflectance and catalyzed thermal emittance (Singh et al. 2010; Howden-Chapman et al. 2007). Cool roof coatings in the form of a liquid applied membrane (LAM) are a promising, low-cost intervention to reduce indoor temperatures that may prove suitable for immediate wide-spread use across new and existing building stocks. Cool roofs that reflect direct sunlight can stay cooler than roofs that absorb sunlight. Solar reflectance (the ability to reflect the visible wavelengths of sunlight, reducing heat transfer to the surface) and thermal emittance (the ability to radiate absorbed solar energy) are the two main mechanisms through which cool roofs reduce indoor heat (Levinson et al. 2002). In clear skies, up to 95% of solar radiation is absorbed by a typical roof surface; cool roofs can substantially reduce this fraction (Dabaieh et al. 2015).

LAMs are sprayed or painted on the roof surfaces and seem to be the most suitable cool roof technology for existing homes in Nouna, Burkina Faso, because they can effectively coat surfaces with undulations or complex roofing structures such as mud bricks or corrugated tin. Different LAM types have different Solar Reflectance Indices (SRIs), which indicate the level of solar reflectivity. LAM substances can also be easily transported and are created on site.

Furthermore, LAM roofs have minimal upfront costs, zero maintenance costs, and possible co-benefits of carbon emission reduction and air quality improvements. Despite the potential for alleviating the burden of heat on the poorest households, the effect estimates on environmental and human health outcomes of cool roofs in sub-Saharan Africa remain unknown. The study site is therefore located in north-west Burkina Faso – characterized by hot dry seasons with temperatures exceeding 40 °C and a wet rainy season.

The long-term research goal is to identify viable passive housing adaptation technologies with proven health and environmental benefits to reduce the burden of heat stress in communities affected by heat in Africa. The specific objectives of this study are to:

- (i) Establish the cultural acceptability of different types of LAM-based cool roofs in Nouna, Burkina Faso
- (ii) Establish the effect of the cool roof on the primary endpoint heart rate as an indicator of physiological stress
- (iii) Determine the effects of the cool roof on a range of secondary endpoints, including indoor temperature, indoor humidity, cardiovascular morbidity and mortality, household energy consumption, and socioeconomic outcomes

## Procedures

Within the RU, this project will start in January 2020 to test a cool-roof coating on mud-brick and tin roofs in Burkina Faso. The project will collect health, environmental, and economic outcome measures, with the primary outcomes being health-related, including heart rate and core body temperature.

First, a formative qualitative study will be conducted to establish the cultural acceptability of the cool roofs. Several versions of the cool roof are possible, with different appearances and different technical properties. For the successful execution of this trial and for long-term impact, it will be important to understand how best to introduce and apply the cool roof in a community and in individual homes and which color and surface material to offer. The trial will start with a formative qualitative study to elicit the local meaning of climate adaptation using the cool roof as well as perceptions of and preferences for particular cool roof colors and surface materials. Second, a cool roof mechanism study will be conducted. Before embarking on a large-scale cluster randomized controlled trial, a small-scale study of mechanisms in eight households will be conducted, which will serve two purposes. First, it will provide pilot data to optimally design the trial processes given the real-life constraints of working in rural Burkina Faso. Second, it will provide fundamental quantitative insights into the physical mechanisms of the cool roof. Most importantly, the third part will comprise a cluster-randomized controlled effectiveness trial. To date, the effects of cool roofs has not been tested in randomized controlled trials, even though such rigorous causal tests are highly feasible. In addition, there have been no studies of cool roof effectiveness in sub-Saharan Africa, the subcontinent where both the effects of climate change will be most severe and the current capacity to adapt to climate change is most limited. Thus this study will be the first cool roof cluster-randomized controlled trial (cRCT) to establish the effects of the technology on critical heat, health, and socioeconomic outcomes in 600 households. The target primary and secondary endpoints include home temperature and humidity, heart rate, core body temperature, hydration status, thermal comfort, cognition, blood pressure, and clinic and hospital utilization.

---

## Strategy 3: Index-Based Weather Insurance in Rural Burkina Faso

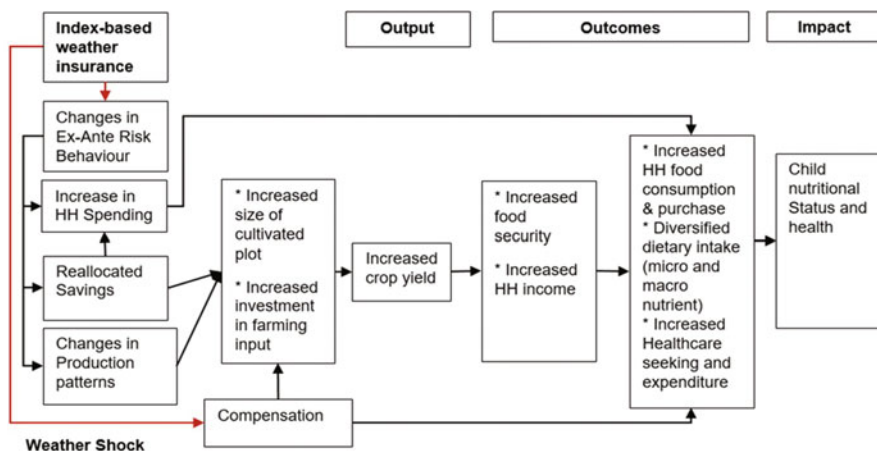
### Background

Emerging evidence highlights the role of climate change in the rise of climate variability and extremes around the globe (Kotir 2011). In turn, increased climate variability and extremes negatively affect the overall stability of global food systems through the decrease in food production (Rosenzweig et al. 2001). Climate change-induced production disruptions increase rural small-holder farmers' vulnerability to undernutrition and poverty (Herrera et al. 2018). This is especially true in sub-Saharan Africa (SSA), where rural households depend mainly on rain-fed subsistence farming and consume around 70% of what they produce (Belesova et al. 2018).

A plethora of adaptation strategies (such as crop diversification, savings, credit, informal risk-sharing arrangements at the community level) has been proposed to address the risk that climate change poses to food production (Dercon et al. 2014). Index-based weather insurance (IBWI) emerges as a promising solution vis à vis traditional crop insurance which suffers from high operational costs and premium because the indemnity payment requires strenuous verification of production losses on each farm. The verification process can be challenging in settings where farms are small and scattered, as is the case in smallholder subsistence farming in rural SSA (Leblois and Quirion 2013). In contrast, IBWI ameliorates the high operational costs and the cumbersome indemnity verification process by making indemnity payments conditional upon an objective and independently measurable weather index (e.g., rainfall or temperature index) (Skees 2008). Payment to the insured is triggered when the index falls below or above a pre-agreed threshold (Carter et al. 2014). IBWI is by no means the panacea for handling all farm losses risk faced by small-scale farmers but stands as the option with the most significant potential of “getting the big risk out of the way” (Skees 2008).

### Procedures

With specific regard to the field of research, IBWI is expected to produce health gains through two distinct impact pathways that are depicted in Fig. 3. First, IBWI will expectedly improve health by improving nutritional status thanks to improved food security. Second, households who enjoy IBWI protection are anticipated to experience a lower need for saving and hence to have more disposable income for other expenses, including health service utilization, a fundamental element to maintain and restore one’s health. There exist approximately 18 IBWI schemes in SSA. The majority of



**Fig. 3** Impact pathways of index-based weather insurance to improve health among smallholder subsistence farming families

these schemes are in operation, but face multiple challenges pertaining to the demand, index design, and institutional support (Hess and Hazell 2016).

So far, the literature on IBWI has concentrated on index design problems such as basis risk and farmer characteristics that influence demand and uptake of IBWI. Less is known about how the different stakeholders (national and global policy agents, first-line implementers, and beneficiaries) interact in the design and implementation of IBWI and how this interaction might affect the success and scalability of IBWI (Duru 2016). In particular, since the literature on IBWI has been dominated by development and agricultural economics, little attention has been paid to whether concerned stakeholders conceptualize the link between insurance and health, via the causal links outlined earlier. To bridge this knowledge gap during the RU lifetime (2020–2022), a political economy analysis (PEA) (Participants at the Bellagio Workshop on Political Economy of Global Health 2015) will be conducted to understand institutional interactions of the different stakeholders involved in the design and implementation of IBWI. The PEA will be grounded in document analysis and key informant interviews, to examine how structures, institutions, and agents work towards the implementation of IBWI in Burkina Faso and Kenya. In light of recent literature highlighting polycentric governance as a driving force of policy development in LMICs, the work will also address the role of international agencies in shaping the emergence of IWBI as a climate change adaptation strategy in SSA.

---

## **Strategy 4: Larviciding Against Malaria Vectors in Rural Burkina Faso**

### **Background**

Despite intense worldwide efforts, malaria is still the world's most important and deadly tropical mosquito-borne parasitic disease. It is responsible for an estimated 435,000 deaths and 219 million disease cases (WHO 2019). Variation in climatic parameters such as temperature, rainfall amount and patterns, and humidity are known to exert influence on malaria transmission through direct influence on the life cycle of vector mosquitoes and malaria parasites (Okuneye et al. 2019).

Climate change is likely to worsen the malarial situation in many areas where malaria transmission already takes place, while, at the same time, it might grant relief in few other regions (Murdock et al. 2016). Additionally, new areas that have been traditionally malaria free, such as regions in the cooler climate and at a higher altitude, will experience an increased risk for transmission. Climate change greatly impacts and alters the El Niño cycle that is known to be associated with increased risks of some diseases transmitted by mosquitoes, such as malaria, dengue, and Rift Valley fever (Mabaso and Ndlovu 2012). In dry climates, heavy rainfall can provide good breeding conditions for the mosquitoes, while droughts in wetter areas can facilitate the formation of more mosquito breeding sites. Climate change together with an increase in resistance of vectors against insecticides and observed changes in mosquito biting behavior poses a threat to the efficacy of traditional

vector control measures such as impregnated nets and indoor residual spraying that are currently in place (Ashley et al. 2014; Killeen et al. 2016; Thomas and Read 2016). For securing and improving current achievements in malaria vector control in a changing climate, it is more important than ever to administer control efforts in an integrated fashion, adding additional approaches, without pulling out from the already implemented ones.

Several of these shortcomings in current malaria vector control can be addressed, to varying extent, by extending control efforts to vector larvae. Other than chemicals such as DDT that were used in previous control and eradication efforts, modern vector larvae control can rely on biological larvicides such as *Bacillus thuringiensis israelensis* (*Bti*). Those are environmentally safe, target species-specific in their mode of action, and show no resistances (Becker 2000). Within the last decade, there has been generated a large body of evidence, showing that *Bti*-based larviciding can bring down malaria vector populations by order of magnitude and significantly reduce malaria prevalence (Tusting et al. 2013; Dambach et al. 2019). One of the main advantages of larviciding is that the vector larvae cannot elude intervention, and they can be targeted where they are concentrated and easily detectable. Dambach et al. have already shown in 2016 that *Bti*-based larviciding can be provided at low cost, similar to or lower than those of LLINs (Dambach et al. 2016; Maheu-Giroux and Castro 2014). Future formulations of *Bti* with increased residual effect and the use of new substances such as insect growth regulators are likely to reduce intervention costs further.

## Procedures

The way of how larviciding is carried out depends on the used larvicide. The most common approach is to perform larviciding during the period of highest malaria transmission, which follows the period of highest vector abundance, which, in most settings, is the rainy season. In the case of *Bti*, the mostly used larvicide formulation is dissolved in water and then brought out with knapsack sprayers onto the surface of potential mosquito breeding sites such as ponds, puddles, roadside ditches but equally to smaller features such as tire marks or hoof prints that are filled with water (Fig. 4). Within several hours up to 1-day posttreatment, the larval stages of mosquitoes will have died off, which can be confirmed by visual control. Due to *Bti*'s organic structure and sedimentation, it loses efficacy after a few days and reapplication is required (Dambach et al. 2014). In tropical climate, this retreatment interval is shorter compared to higher latitudes, and larviciding has to be carried out again every 8–10 days. Hence, depending on the duration of the rainy season, and the ambient temperature, only a few up to more than ten treatment rounds might be needed to effectively control vector populations. Besides the implementation of a meticulously followed spraying calendar, it can be beneficial to monitor larviciding success as a part of quality control, in particular during the first time of carrying out. The first step of program quality control is performed by determining the larvae kill-off rate. As a next step,



**Fig. 4** Project members are spraying a stagnant body of water in Burkina Faso, in which mosquitoes develop, with the biological insecticide *bti*. (© Dr. Peter Dambach, Heidelberg Institute of Global Health (HIGH), Universitätsklinikum Heidelberg, Germany)

adult vector abundance is monitored through different types of traps and catchment techniques and compared to a pre-intervention baseline or an untreated reference area.

---

## Conclusions

Herein, presented four viable and propagated adaptation strategies are presented to support populations in sub-Saharan Africa in their development of climate-resilience. These projects are united by their careful alignment of design research, early involvement of stakeholders and decision-makers, and scientific evaluation of health outcomes as well as economic returns. Global climate change mitigation efforts are certainly needed. Still, climate change impacts on health are already discernible in rural Burkina Faso and Kenya. These transformative projects will enhance the local adaptive capacities for combatting the major health problems undernutrition, cardiovascular heat-stress, and malaria in these regions.

**Acknowledgments** This writing of this chapter has been supported by Prof. Rainer Sauerborn and Prof. Manuela De Allegri (Heidelberg Institute of Global Health (HIGH), Heidelberg University, Im Neuenheimer Feld 130.3 69120 Heidelberg, Germany) as well as Dr. Penelopé Vounatsou (Swiss Tropical and Public Health Institute, Socinstrasse 57 CH-4051 Basel, Switzerland).

---

## References

AMCEN, UNEP, and Climate Analytics (2013) Africa's adaptation gap: climate-change impacts, adaptation challenges and costs for Africa. UNEP, Geneva

- Ashley EA, Dhorda M, Fairhurst RM, Amaratunga C, Lim P, Suon S, Sreng S, Anderson JM, Mao S, Sam B, Sopha C, Chuor CM, Nguon C, Sovannaroeth S, Pukrittayakamee S, Jittamala P, Chotivanich K, Chutasmit K, Suchatsoonthorn C, Runcharoen R, Hien TT, Thuy-Nhien NT, Thanh NV, Phu NH, Htut Y, Han KT, Aye KH, Mokuolu OA, Olaosebikan RR, Folaranmi OO, Mayxay M, Khanthavong M, Hongvanthong B, Newton PN, Onyamboko MA, Fanello CI, Tshefu AK, Mishra N, Valecha N, Phyo AP, Nosten F, Yi P, Tripura R, Borrmann S, Bashraheil M, Peshu J, Faiz MA, Ghose A, Hossain MA, Samad R, Rahman MR, Hasan MM, Islam A, Miotto O, Amato R, MacInnis B, Stalker J, Kwiatkowski DP, Bozdech Z, Jeeyapant A, Cheah PY, Sakulthaew T, Chalk J, Intharabut B, Silamut K, Lee SJ, Vihokhern B, Kunasol C, Imwong M, Tarning J, Taylor WJ, Yeung S, Woodrow CJ, Flegg JA, Das D, Smith J, Venkatesan M, Plowe CV, Stepniewska K, Guerin PJ, Dondorp AM, Day NP, White NJ, Tracking Resistance to Artemisinin Collaboration (TRAC) (2014) Spread of artemisinin resistance in *Plasmodium falciparum* malaria. *N Engl J Med* 371:411–423
- Becker N (2000) Bacterial control of vector-mosquitoes and black flies. In: Entomopathogenic bacteria: from laboratory to field application. Springer, Dordrecht, pp 383–398
- Belesova K, Gasparini A, Sié A, Sauerborn R, Wilkinson P (2018) Annual crop-yield variation, child survival, and nutrition among subsistence farmers in Burkina Faso. *Am J Epidemiol* 187:242–250
- Bizikova L, Habtezion L, Bellali J, Diakhite M, Pinter L (2009) Vulnerability and climate change impact assessments for adaptation. Retrieved from <https://www.unenvironment.org/resources/report/vulnerability-and-climate-change-impact-assessments-adaptation-module>. Accessed 8 Nov 2018
- Caminade C, Kovats S, Rocklov J, Tompkins AM, Morse AP, Colón-González FJ, Stenlund H, Martens P, Lloyd SJ (2014) Impact of climate change on global malaria distribution. *P Natl Acad Sci* 111:3286–3291
- Carter M, De Janvry A, Sadoulet E, Sarris A (2014) Index-based weather insurance for developing countries: a review of evidence and a set of propositions for up-scaling (no. 111). Retrieved from [http://www.ferdi.fr/sites/www.ferdi.fr/files/publication/fichiers/wp111\\_index\\_insurance\\_web\\_0.pdf](http://www.ferdi.fr/sites/www.ferdi.fr/files/publication/fichiers/wp111_index_insurance_web_0.pdf)
- Constanzo A, Bàrberi P (2013) Functional agrobiodiversity and agroecosystem services in sustainable wheat production. A review. *Agron Sustain Dev* 34:327–348
- Costello A, Abbas M, Allen A, Ball S, Bell S, Bellamy R, Friel S, Groce N, Johnson A, Kett M, Lee M, Levy C, Maslin M, McCoy D, McGuire B, Montgomery H, Napier D, Pagel C, Patel J, de Oliveira JAP, Redclift N, Rees H, Rogger D, Scott J, Stephenson J, Twigg J, Wolff J, Patterson C (2009) Managing the health effects of climate change. *Lancet* 373:1693–1733
- Dabaieh M, Wanas O, Hegazy MA, Johansson E (2015) Reducing cooling demands in a hot dry climate: a simulation study for non-insulated passive cool roof thermal performance in residential buildings. *Energ Buildings* 89:142–152
- Dambach P, Louis VR, Kaiser A, Ouedraogo S, Sié A, Sauerborn R, Becker N (2014) Efficacy of *Bacillus thuringiensis* var. *israelensis* against malaria mosquitoes in northwestern Burkina Faso. *Parasit Vectors* 7:371
- Dambach P, Schleicher M, Stahl HC, Traoré I, Becker N, Kaiser A, Sié A, Sauerborn R (2016) Routine implementation costs of larviciding with *Bacillus thuringiensis israelensis* against malaria vectors in a district in rural Burkina Faso. *Malar J* 15:380
- Dambach P, Baernighausen T, Traoré I, Ouedraogo S, Sié A, Sauerborn R, Becker N, Louis VR (2019) Reduction of malaria vector mosquitoes in a large-scale intervention trial in rural Burkina Faso using *Bti* based larval source management. *Malar J* 18:311
- Danquah I, Dietz E, Zanger P, Reither K, Ziniel P, Bienzle U, Mockenhaupt FP (2009) Reduced efficacy of intermittent preventive treatment of malaria in malnourished children. *Antimicrob Agents Chemother* 53(5):1753–1759
- Dasgupta S (2018) Burden of climate change on malaria mortality. *Int J Hyg Envir Heal* 221:782–791
- Dercon S, Vargas Hill R, Clarke D, Outes-Leon I, Alemayehu ST (2014) Offering rainfall insurance to informal insurance groups: evidence from a field experiment in Ethiopia. *J Dev Econ* 106:132–143

- Duru MJ (2016) Too certain to invest? Public safety nets and insurance markets in Ethiopia. *World Dev* 78:37–51
- Grace K, Davenport F, Funk C, Lerner A (2012) Child malnutrition and climate in sub-Saharan Africa: an analysis of recent trends in Kenya. *Appl Geogr* 35:405–413
- Herrera C, Ruben R, Dijkstra G (2018) Climate variability and vulnerability to poverty in Nicaragua. *J Environ Econ Policy* 7:324–344
- Hess U, Hazell P (2016) Innovations and emerging trends in agricultural insurance: how can we transfer natural risks out of rural livelihoods to empower and protect people? Eschborn. Retrieved from [https://www.giz.de/de/downloads/giz-2016-en-innovations\\_and\\_emerging\\_trends-agricultural\\_insurance.pdf](https://www.giz.de/de/downloads/giz-2016-en-innovations_and_emerging_trends-agricultural_insurance.pdf)
- Howden-Chapman P, Matheson A, Crane J (2007) Effect of insulating existing houses on health inequality: cluster randomised study. *BMJ* 337:334–460
- IAASTD (2009) International assessment of agricultural knowledge, science and technology for development. Global report. Retrieved 7 Nov 2014, from <http://apps.unep.org/publications/pmtdocuments/-Agriculture%20at%20a%20crossroads%20-%20Synthesis%20report-2009Agriculture>
- IPCC (2017) Chapter XII. Human health: impact, adaptation and vulnerabilities. In: Working group II, 6th assessment report. IPCC, Geneva
- Janko MM, Irish SR, Reich BJ, Peterson M, Doctor SM, Mwandagalirwa MK, Likwela JL, Tshetu AK, Meshnick SR, Emch ME (2018) The links between agriculture, Anopheles mosquitoes, and malaria risk in children younger than 5 years in the Democratic Republic of the Congo: a population-based, cross-sectional, spatial study. *Lancet Planet Health* 2(2):e74–e82. [https://doi.org/10.1016/S2542-5196\(18\)30009-3](https://doi.org/10.1016/S2542-5196(18)30009-3)
- Killeen GF, Govella NJ, Lwetoijera DW, Okumu FO (2016) Most outdoor malaria transmission by behaviourally-resistant *Anopheles arabiensis* is mediated by mosquitoes that have previously been inside houses. *Malar J* 15:225
- Kjellstrom T, Freyberg C, Lemke B, Otto M, Briggs D (2017) Estimating population heat exposure and impacts working people in conjunction with climate change. *Int J Biometeorol* 62:291–306
- Kotir JH (2011) Climate change and variability in sub-Saharan Africa: a review of current and future trends and impacts on agriculture and food security. *Environ Dev Sustain* 13:587–605
- Leblois A, Quirion P (2013) Agricultural insurances based on meteorological indices: realizations, methods and research challenges. *Meteorol Appl* 20:1–9
- Levinson R, Akbari H, Konopacki S, Bretz S (2002) Inclusion of cool roofs in nonresidential Title 24 prescriptive requirements. *Energy Policy* 33:151–170
- Mabaso MLH, Ndlovu NC (2012) Critical review of research literature on climate-driven malaria epidemics in sub-Saharan Africa. *Public Health* 126:909–919
- Maheu-Giroux M, Castro MC (2014) Cost-effectiveness of larviciding for urban malaria control in Tanzania. *Malar J* 13:477
- Murdock CC, Sternberg ED, Thomas MB (2016) Malaria transmission potential could be reduced with current and future climate change. *Sci Rep* 6:27771
- Myers SS, Zanobetti A, Kloog I, Huybers P, Leakey AD, Bloom AJ, Carlisle E, Dietterich LH, Fitzgerald G, Hasegawa T, Holbrook NM, Nelson RL, Ottman MJ, Raboy V, Sakai H, Sartor KA, Schwartz J, Seneweera S, Tausz M, Usui Y (2014) Increasing CO<sub>2</sub> threatens human nutrition. *Nature* 510(7503):139–142
- Okuneye K, Eikenberry SE, Gumel AB (2019) Weather-driven malaria transmission model with gonotrophic and sporogonic cycles. *J Biol Dyn* 13:288–324
- Olney DK, Pedehombga A, Ruel MT, Dillon A (2015) A 2-year integrated agriculture and nutrition and health behavior change communication program targeted to women in Burkina Faso reduces anemia, wasting, and diarrhea in children 3–12.9 months of age at baseline: a cluster-randomized controlled trial. *J Nutr* 145(6):1317–1324
- Participants at the Bellagio Workshop on Political Economy of Global Health (2015) Report from Bellagio: advancing political economy of global health to understand and influence the drivers of universal health coverage. *Health Syst Reform* 1:20–21



- Rosenzweig C, Iglesias A, Yang XB, Epstein P, Chivian E (2001) Climate change and extreme weather events – implications for food production, plant disease, and pests. *Glob Chang Hum Health* 2:90–104
- Schellnhuber HJ, Hare W (2013) Turn down the heat: climate extremes, regional impacts, and the case for resilience. World Bank, Washington, DC
- Sibhatu KT, Krishna VV, Qaim M (2015) Production diversity and dietary diversity in smallholder farm households. *Proc Natl Acad Sci U S A* 112(34):10657–10662
- Singh A, Syal M, Grady SC, Korkmaz S (2010) Effects of green buildings on employee health and productivity. *Am J Public Health* 100:1665–1668
- Skees JR (2008) Challenges for use of index-based weather insurance in lower income countries. *Agric Financ Rev* 68:197–217. Retrieved from <https://www.uky.edu/Ag/AgEcon/pubs/resWeatherInsLIC44.pdf>
- Smith MR, Myers SS (2018) Impact of anthropogenic CO<sub>2</sub> emissions on global human nutrition. *Nature Climate Change* 8:834–839
- Thomas MB, Read AF (2016) The threat (or not) of insecticide resistance for malaria control. *Proc Natl Acad Sci U S A* 113:8900–8902
- Tusting LS, Thwing J, Sinclair D, Fillinger U, Gimnig J, Bonner KE, Bottomley C, Lindsay SW (2013) Mosquito larval source management for controlling malaria. *Cochrane Database Syst Rev* 8:CD008923
- Watts N, Adger WN, Agnolucci P, Blackstock J, Byass P, Cai W, Chaytor S, Colbourn T, Collins M, Cooper A, Cox PM, Depledge J, Drummond P, Ekins P, Galaz V, Grace D, Graham H, Grubb M, Haines A, Hamilton I, Hunter A, Jiang X, Li M, Kelman I, Liang L, Lott M, Lowe R, Luo Y, Mace G, Maslin M, Nilsson M, Oreszczyn T, Pye S, Quinn T, Svendsdotter M, Venevsky S, Warner K, Xu B, Yang J, Yin Y, Yu C, Zhang Q, Gong P, Montgomery H, Costello A (2015) Health and climate change: policy responses to protect public health. *Lancet* 386:1861–1914
- WHO (2014) Quantitative risk assessment of the effects of climate change on selected causes of death, 2030s and 2050s. WHO, Geneva
- WHO (2019) World malaria report 2018. Retrieved from <http://www.who.int/malaria/publications/world-malaria-report-2018/en/>
- Woodward A, Smith K, Campbell-Lendrum D, Chadee D, Honda Y, Liu Q, Olwoch J, Revich B, Sauerborn R, Chafe Z, Haines A (2014) Climate change and health: the latest report from the IPCC. *Lancet* 383:1185–1189
- World Bank (2017) Living Standards Measurement Study (LSMS). Retrieved from <https://microdata.worldbank.org/index.php/catalog/lsms>
- World Bank (2018) Country profiles of Burkina Faso and Kenya. Retrieved from <https://data.worldbank.org/country/>

**Open Access** This chapter is licensed under the terms of the Creative Commons Attribution 4.0 International License (<http://creativecommons.org/licenses/by/4.0/>), which permits use, sharing, adaptation, distribution and reproduction in any medium or format, as long as you give appropriate credit to the original author(s) and the source, provide a link to the Creative Commons license and indicate if changes were made.

The images or other third party material in this chapter are included in the chapter's Creative Commons license, unless indicated otherwise in a credit line to the material. If material is not included in the chapter's Creative Commons license and your intended use is not permitted by statutory regulation or exceeds the permitted use, you will need to obtain permission directly from the copyright holder.





# Sustainable Climate Change Adaptation in Developing Countries: Role of Perception Among Rural Households

# 121

Oluwatosin Oluwasegun Fasina, Emmanuel Chilekwu Okogbue,  
Oluwatosin Omowunmi Ishola, and Abiodun Adeeko

## Contents

Introduction .....	2502
Literature Review .....	2504
Sustainable Climate Change Adaptation .....	2504
The Concept of Perception in Climate Change Adaptation .....	2504
Description of the Study Areas and Methodology .....	2504
Study Area .....	2504
Research Methods .....	2505
Results and Discussion .....	2506
Primary Livelihoods of Rural Households .....	2506
Climate Change Coping and Adaptation Strategies Employed in Rural Livelihoods .....	2507

---

This chapter was previously published non-open access with exclusive rights reserved by the Publisher. It has been changed retrospectively to open access under a CC BY 4.0 license and the copyright holder is “The Author(s)”. For further details, please see the license information at the end of the chapter.

---

O. O. Fasina  
School of Agriculture and Agricultural Technology, Federal University of Technology, Akure,  
Akure, Nigeria  
e-mail: [royalambfuta@gmail.com](mailto:royalambfuta@gmail.com)

E. C. Okogbue  
School of Meteorology and Climate Science, Federal University of Technology, Akure, Akure,  
Nigeria  
e-mail: [ecokogbue@futa.edu.ng](mailto:ecokogbue@futa.edu.ng)

O. O. Ishola (✉) · A. Adeeko  
Federal College of Agriculture, Agricultural Extension and Management, Akure, Ondo State,  
Nigeria  
e-mail: [tosiniso@gmail.com](mailto:tosiniso@gmail.com); [dkabiodun@gmail.com](mailto:dkabiodun@gmail.com)

Perception of Climate Change Among Rural Households .....	2510
Relationship Between Perception and Coping Strategies of Respondents .....	2513
Conclusion .....	2515
References .....	2515

## Abstract

Climate change adaptation entails exploiting not only economically but also environmentally beneficial strategies by all stakeholders. However, the successful implementation of adaptation actions is also subject to the perception of climate change, usually influenced by knowledge, experiences, and sociocultural factors including gender relations, among the target group. This chapter analyzes the perception of climate change among rural households in Southwest Nigeria and ascertains the coping and adaptation strategies in use among the households. A total of 239 respondents were interviewed across the vegetative zones available in the study area. Findings revealed that 54.8% were involved in crop farming. About 51.0% and 45.6% practiced change in sowing date and harvest date, respectively. Respondents' perception had a significant relationship with adaptation measures such as change in harvest date ( $\chi^2 = 56.753$ ,  $p = 0.026$ ), planting improved varieties ( $\chi^2 = 55.866$ ,  $p = 0.031$ ), and mixed cropping ( $\chi^2 = 55.433$ ,  $p = 0.042$ ). Respondents had a favorable perception of climate change. The study concluded that although their perception of climate change was favorable and indicated their understanding of its negative effects on their livelihoods, it did not take cognizance of women's insecure access to production resources. It recommended the development of easily accessible weather forecasts to aid livelihood decisions and enlightenment on improved women's access to production resources and biodiversity protection.

## Keywords

Sustainable adaptation strategies · Perception · Rural livelihoods · Southwest Nigeria

## Introduction

Rural livelihoods comprise a diversity of capabilities, assets, and activities that rural people, households, and communities require to earn and secure their living (FAO 2003). Climate change threatens and erodes these assets, thereby hampering income generation and perpetuating poverty (IPCC 2007). However, the successful implementation of climate change adaptation strategies, which are essential to adjusting and reducing its negative impacts on food security, is influenced by rural households' perception of climate change (Apurba and Haque 2017).

In developing countries, climate change is occurring in the midst of other developmental stressors, such as poverty, fluctuating oil prices, and land

degradation. Adaptation strategies are aimed at lowering the vulnerability of natural and human systems to climate change so as not to frustrate food security and poverty reduction efforts (Bhatasara and Nyamwanza 2017). Due to its effect in slowing down economic growth, national governments have integrated climate change adaptation measures into their policy frameworks. At the local level, households adopt diverse strategies in their livelihoods to cope with climate change. They include change in planting date, livelihood diversification, borrowing, zero tillage, rationing, afforestation, planting improved crop varieties, and sale of assets, such as livestock (Akinbami et al. 2016; Abdulai et al. 2017). In the face of climate change, the survival of rural livelihoods is facilitated by adaptation strategies as they ensure

- (i) Food security
- (ii) A more reliable income flow for the welfare of households

However, as Agyei (2016) pointed out, the question of the sustainability of adaptation strategies must be answered before they are pursued. More important to the achievement of sustainable adaptation frameworks are the barriers to their implementation, including sociocultural barriers (Antwi-Agyei et al. 2014). Sociocultural barriers could stem from the values, beliefs, and norms of people. These factors shape their perception of climate change – a vital element that determines the adoption of sustainable adaptation strategies (Yaro 2006; Moser and Ekstrom 2010). Perceptions are gaining more recognition in climate change and adaptation studies because past experiences, observations, and future expectations of rural households may influence the choice of adaptation strategy employed to address climate change impacts (Maddison 2007).

Perceptions have been found to be one of the factors driving the choice of adaptation and mitigation strategies, thereby necessitating its integration in the design and development of climate-smart interventions for rural livelihoods, particularly agriculture (Grimberg et al. 2018). Five general classes of impediments to adaptation have been identified. They are financial, technological, cognitive, cultural, and institutional impediments. Local adaptive capacity recognizes not only the capitals and the resource-based components of adaptive capacity at local levels but also the intangible and dynamic factors such as perception (Jones et al. 2017). Rural livelihoods become more resilient when households are able to perceive first, the impacts of climate change, as well those of inappropriate adaptation measures (Alam et al. 2017). The study therefore aims to assess the perception of climate change among rural households in order to achieve sustainable climate adaptation.

Assessing perception of climate change among rural households will provide household-level data to aid the understanding of their resource exploitation behavior, capabilities, and challenges. In this way, local, context-specific sustainable adaptation policies can be developed in order to address climate change issues and the interrelationship between livelihoods and gender concerns in rural areas. The study, therefore, aimed to ascertain the coping and adaptation strategies employed by rural households in their livelihoods and determine their perception of climate change.

---

## Literature Review

### Sustainable Climate Change Adaptation

Sustainable climate change adaptation entails the exploitation of available resources to meet present needs without jeopardizing the ability to meet future needs. It facilitates the pursuit of profitable livelihoods in a healthy environment. It, therefore, requires that rural households first become aware that climate change is real, understand the dynamic causes, and recognize available valuable adaptation strategies that are not only economically but also environmentally friendly before successful implementation can be achieved (Osumanu et al. 2017). If rural livelihoods are to recover from stresses and shocks while also sustaining their capabilities and assets without compromising the natural resource base, rural households must recognize that certain adaptation choices are capable of creating more harm than benefits in the long run (Bhatasara and Nyamwanza 2017).

### The Concept of Perception in Climate Change Adaptation

Perception is formed from the combination of small bits of information about the environment and creating a duplicate internal representation. Perception refers to an individual's or group's unique way of viewing a phenomenon. It involves the processing of stimuli, memories, and experiences in the process of understanding. This highlights the three essential features of perception: (i) a sensory or cognition of the experience, (ii) personal experiences that help in interpreting and understanding a phenomenon, and (iii) comprehension that can lead to a response (Galotti 1994; McDonald 2012).

In relating perceptions to adaptation, studies (Asrat and Simane 2018; Zoundji et al. 2017; Ndamani and Watanabe 2015) have shown that as perception is dynamic, so is adaptation location-specific and influenced by key drivers such as socioeconomic, environmental, and institutional factors. Observations produce knowledge. Perceptions are interpretation of observations in connection to existing knowledge. Perceptions (of the effects of a chosen adaptation strategy) can combine with existing knowledge to produce adjusted or new action. However, before adaptation action takes place, people must first perceive the reality of climate change and its impacts (Asrat and Simane 2018; Alam et al. 2017).

---

## Description of the Study Areas and Methodology

### Study Area

The study was conducted in the Southwest of Nigeria in 2018. Southwest Nigeria (also referred to as the Southwest geopolitical zone) has been experiencing intense dynamics of rapid socioeconomic development, land use, and population

growth. It is made up of six states – Ekiti, Lagos, Ogun, Ondo, Osun, and Oyo. The area lies between longitude  $2^{\circ} 31'$  and  $6^{\circ} 00'$  East and latitude  $6^{\circ} 21'$  and  $8^{\circ} 37'$  North. It has a surface area of about 78,505 km<sup>2</sup>, population of 17,455,052 people, and a population density of 353 persons/km<sup>2</sup> (NPC 2006). It is bound in the east by Edo and Delta states, in the north by Kwara and Kogi states, in the west by the Republic of Benin, and in the South by the Atlantic Ocean (Faleyimu et al. 2010).

The climate of Southwest Nigeria is tropical in nature and is characterized by wet and dry seasons (Faleyimu et al. 2010). The dry season is short, lasting generally from December to February. The average annual rainfall is 1,200–1,500 mm. The monthly mean temperature ranges from about 22.49 °C to 31.24 °C, while the average annual temperature is about 26.6 °C. Furthermore, temperature is relatively high during the dry season and low during the rainy season, especially between July and August (Oyinloye and Oloukoi 2013). The average annual relative humidity is about 76.05%. The relatively high rainfall usually precipitates widespread flooding in some parts of the region. However, the indiscriminate exploitation of the environment has contributed to recent flood events.

There are three main types of vegetation in the region – mangrove forest which is found mainly in Lagos state and some parts of Ogun and Ondo states; tropical rain forest which is found mainly in Ogun, Ondo, Ekiti, and some parts of Oyo state; and, lastly, guinea and derived savanna found mainly in Osun and some parts of Oyo and Ogun states. Most of the rivers are short, north-south coastal rivers. The major rivers include Ogbese, Ogun, Ogunpa, Oluwa, Ominla, Oni, and Owena (Oyinloye and Oloukoi 2013).

The predominant economic activities are farming, trading, and artisanship. The climate favors the propagation of crops like yam, cassava, rice, plantains, cocoa, kola nut, oil palm, and maize, among others. As a result, majority of the inhabitants are farmers who practice farming enterprises ranging from crop production, livestock breeding, forestry practices, fisheries and aquaculture to agricultural processing (NPC 2006).

## Research Methods

### Study Site Selection and Sampling Methods

Lagos, Ondo, and Oyo states were purposively selected to represent the vegetation zones in the study area – Lagos (mangrove and coastal swamp), Oyo (rainforest and derived savanna), and Ondo (rainforest and coastal). The research was conducted in Badagry, Epe, Akure North, Eseodo, Ifedore, Ilaje, and Ibarapa Central and Ibarapa North local government areas (LGAs). Five communities were randomly selected from each LGA to yield a total of 40 communities. A random selection of 6 households from each of the 40 communities gave 240 households. In-depth interview with 16 community key informants was carried out. Key informant selection and interviews were carried out in consultation with enumerators and community members.

## Data Sources and Collection Methods

The study utilized both quantitative and qualitative data. These were gathered from household heads through interview schedule and questionnaire survey as well as interviews for key informants. Data on local coping and adaptation strategies employed by the households were obtained using the survey. Data on perception were obtained using Likert-type scale items. Interviews with key informants and overt observation provided information on nature of farming and other livelihood activities, local gender dimensions, climate change impacts in the communities, coping strategies employed, and underlying social challenges.

## Data Analysis

Both descriptive and inferential statistics were used in analyzing the coping and adaptation strategies employed by the households and their perception of climate change. SPSS was used to analyze quantitative data. A chi-square analysis was carried out to determine if there was a relationship between the perception of the rural households and their choice of coping and adaptation strategies. The mean of the perception statements was used. Analysis of qualitative data was done in the context of interview themes.

---

## Results and Discussion

While the study sought to elicit information from both male-headed and female-headed households in order to disaggregate data on gender basis, there was inadequate female-headed household sample size. Moreover, some of the women were unwilling to be interviewed due to their gender roles of cooking for the household and childcare. As a result, male-headed households made up most of the sample. Although 240 respondents were intended for the study, information was obtained from 239.

## Primary Livelihoods of Rural Households

As is typical of rural communities, Southwest Nigeria is agrarian in nature. Many households are involved in agriculture for both family consumption and income generation. However, nonfarm livelihoods are nonetheless important. Some of these livelihoods are agro-allied in nature, e.g., processing and trading of farm produce. Table 1 displays the livelihoods of the rural households.

Many of the households were involved in crop farming as it was the primary livelihood source for 54.8% of the households. This was followed by trading/business as approved by 14.6% of the households. Fishing ranked third as 10.9% of the households claimed it was their primary source of livelihood. Both processing and artisanship ranked fourth because 6.3% each of the respondents claimed either was their main source of livelihood. Gathering of non-timber

**Table 1** Primary livelihoods of respondents (N = 239)

Livelihood	No. replied	%
Animal husbandry	11	4.6
Trading/business	35	14.6
Processing	15	6.3
Fishing	26	10.9
Artisanship	15	6.3
Gathering of non-timber forest products	4	1.7
Hunting	2	0.8

forest products accounted for 1.7% of the respondents. Only 0.8% claimed hunting was their main source of livelihood.

Interviews with key informants and observations revealed that many of the households were smallholder farmers (average farm size >3.0 ha) involved mainly in maize, yam, cassava, plantain, oil palm, and cocoa. Farmers in the coastal areas were also involved in rice and coconut production. Animal husbandry, although widespread, was mainly for family consumption and for sale to maintain the welfare of the household during periods of hardship. Animals reared include goat, sheep, poultry, and, in some cases, pigs. Although fishing was the main source of livelihood in coastal areas, some households were involved in fish farming (aquaculture). Households involved in trading sold consumer goods which community members would have had to travel to more urbanized centers to buy.

Agriculture is the backbone of many rural economies, ensuring food security, employment, export earnings, and economic development. As Olajide et al. (2012) attested, it employs about 65% of the labor force in Nigeria, while contribution to GDP oscillates between 30% and 42%. However, as revealed by the study, it is worthy of note that the rural sector comprises a diversity of livelihoods and the players range from large and smallholder landlords, landless workers, fishing communities, nonagricultural entrepreneurs including artisans, public institutions, private firms, providers of inputs and services, farmers' organizations, and nongovernmental organizations. Building sustainable and resilient rural livelihoods will, therefore, require that this wide array of stakeholders be given recognition in development initiatives and plans (FAO 2003).

## Climate Change Coping and Adaptation Strategies Employed in Rural Livelihoods

Rural households make adaptation choices to cope with the effect of climate change. Many factors influence the coping and adaptation choices adopted by rural households in the pursuit of their livelihoods. Whether these choices augur well for profitable livelihoods and a healthy environment is also another challenge addressed by factors such as their level of exposure and awareness, education, income, and cultural affiliation. Table 2 displays the adaptation choices employed by the households in order to ensure thriving enterprises.



**Table 2** Coping and adaptation practices employed in rural livelihoods

No.	Types of coping and adaptation practices (N = 239)	No. replied	%
1	Change in sowing date	122	51.0
2	Change in harvest date	109	45.6
3	Mixed cropping	108	45.2
4	Purchasing extra feed for livestock (in dry season)	5	2.1
5	Planting of improved varieties	82	34.3
6	Afforestation	82	34.3
7	Community aid/support (money, labor, material)	18	7.5
8	Irrigation	78	32.6
9	Seasonal migration	42	17.6
10	Aid from government	33	13.8
11	Use of organic manure	70	29.3
12	Borrowing	35	14.6
13	Using media (TV, radio, mobile phone, etc.) forecasting	28	11.7
14	Sale of assets, e.g., livestock	49	20.5
15	Diversification of livelihoods	86	36.0
16	Construction of barriers and drainage channels	33	13.8
17	Increased watering of soil	28	11.7
18	Fuel conservation	26	10.9
19	Increased watering of livestock	21	8.8

Of all the coping and adaptation strategies, strategies 4, 12, and 13 cannot be regarded as sustainable. Low incomes are a peculiarity of rural areas, and purchasing extra feed for livestock in the dry season will only add to the pressure on their meager earnings. Rural households engage in sale of assets to obtain cash to offset pressing needs. More often than not, rural households lack the required collateral to secure loans from commercial banks. Consequently, they resorted to borrowing. These measures are maladaptive and unsustainable as they erode efforts at food security and poverty reduction. They borrowed from relatives, friends, and credit groups such as *esusu* (informal savings group for mutual access to credit) and farmers' groups. As buttressed by CARE (2011), these actions may appear to have immediate effect in managing crisis; they bear potential negative impacts on households' asset base, health, local biodiversity, and ecosystem. However, groups such as *esusu* and farmers' group can be veritable tools and platforms for improving welfare and achieving poverty reduction among rural households when provided operational resources and capacity.

About 51.0% and 45.6% of the respondents changed sowing and harvest dates, respectively, based on indigenous knowledge and personal observation of weather patterns and climate change impacts. This helped to minimize crop losses. Mixed cropping (45.2%), planting of improved varieties (34.3%), and afforestation (34.3%) were carried out to reduce risk. Mixed cropping serves as a buffer against weather fluctuation and an insurance against crop failure. Households involved in afforestation were those that had orange and kola nut trees. Tree planting was not widespread except for those that planted *Gmelina arborea*. These adaptation measures are

encouraged by agricultural extension because they aid nutrient cycling, improved soil structure, and more reliable income stream. This result is in line with Asrat and Simane (2018) that adaptation strategies such as use of improved varieties and adjusting planting date were favored among farmers and also highlighted the role of extension in sustainable adaptation.

About 11.7% of them utilized weather forecasting services through electronic media in their livelihoods. The ISKA weather forecast service by GIZ is one of such platforms accessed through the mobile phone by respondents in Oyo state. This way, rural households are able to obtain climate information at affordable rates. Such platforms are useful in disaster risk management in developing early warning systems and preparedness of rural households (Antwi-Agyei et al. 2014). They promote the development of more resilient livelihoods.

Occasionally, support is mobilized for the household in form of money, labor, and materials by the community. This safety net is also badly affected by climate change impacts such as flooding, pest infestation and drought. Climate change makes it difficult to garner resources to help households in the community when there is a widespread effect (CARE 2011). Irrigation was employed by 32.6% and 17.6% resorted to seasonal migration. Usually, the irrigation practiced involved fetching water into watering cans from nearby streams to water farms during the dry season. This is because of the high cost of irrigation technology which smallholders cannot afford. Since agriculture in sub-Saharan Africa is basically rain-fed, poor access to irrigation limits production, impairing food production and income generation during dry season and drought. Moreover, the labor required to water the farms places extra strain on the time, energy, and health of household members. Members of rural households migrate in search of employment opportunities on a seasonal basis in order to augment income. However, increasing migration of men from rural areas in search of employment has caused the number of female-headed households to grow substantially (Omonona 2009; Gebre et al. 2019).

Households who obtained aid (such as money and implements) from government constituted 13.8%, while the use of organic manure was adopted by 29.3%. The use of organic manure is made easier where animals are being reared and crop residue can be utilized. Livelihood diversification (36.0%) was done to earn more income, especially into nonfarm or off-farm activities, such as artisanship (Loison 2015). This helps to increase income flow for the households. Construction of barriers and drainage channels was done in the coastal areas. Interview with key informants revealed that barriers were constructed usually by those involved in fish farming in the coastal areas to prevent their fish from being washed away by coastal flooding which could occur as a result of heavy rainfall.

Increased watering of plants prevents them from drying up or wilting which affects fruiting and, consequently, yield. Increased watering of livestock during hot weather reduces the incidence of heat stress among the animals so as not to affect their productivity. Fuel conservation reduces the rate of greenhouse gas emissions.

Table 2 also shows that respondents utilized more of coping and adaptation options that were affordable and easily accessible to them. The strategies include change in sowing and harvest dates, mixed cropping, afforestation, planting

improved varieties, irrigation, and diversification of livelihoods. These strategies that come at little or no cost are favored by many rural households (Alam et al. 2017). For instance, household members assisted in fetching water from nearby streams to water farms.

## Perception of Climate Change Among Rural Households

The belief system of rural households influences their adaptation choices and could either hinder or aid the implementation of sustainable adaptation strategies, especially at the local level. Like any other phenomenon, their understanding or opinion of climate change is shaped by their values, morals, and norms (culture), experiences, indigenous knowledge, education, exposure, opinion leaders in the community, and other factors. Table 3 reveals the opinions of the households as regards climate change.

Respondents agreed to statements 3, 4, 5, 8, 10, 14, and 15. They disagreed with statements 1, 7, 9, 11, 12, and 13. They were undecided about statement 2. Respondents agreed that the protection of biodiversity is impossible with climate change. This is one of the reasons that make rural households opt for unsustainable adaptation choices that jeopardize their livelihoods and environmental sustainability (Osumanu et al. 2017). They agreed that increasing temperatures caused a decrease in their productivity and planting improved varieties could help minimize crop losses. High temperatures, an indicator of global warming, could affect health and cause household members to spend less time on their livelihoods. Improved varieties can withstand harsh weather conditions and still give good yield. They agreed that accumulation of livelihood assets has become much more difficult with climate change. This is because climate change erodes their effort at income generation, food security, and poverty reduction.

They also agreed that local or indigenous knowledge is useful in reinforcing scientific climate information to make it more relevant to rural livelihoods. Local experiences employed in coping with climate change can be integrated with scientific climate knowledge to improve its acceptability and adoption. They agreed that women are vulnerable to climate change due to their insecure access to production resources. They agreed that rampant bush burning in preparation for land cultivation has a negative effect on the environment. This knowledge may be due to their contact with agricultural extension.

Households disagreed with the statement that there has been no change in climatic conditions in recent years. This implies that rural households are experiencing an alteration in weather conditions, evidenced by a dwindling of environmental resources such as water and fuel wood as stated by key informants. They disagreed that climate change does not affect the amount and quality of water, wood, and other natural resources. This is because with climate change, household members responsible for such roles, especially women and children, spend more time in search of water and fuel wood. Usually, they have to search deeper into forests (FAO 2008).

**Table 3** Perception of climate change among rural households (N = 239)

S/N	Perception statement	SA F(%)	A F(%)	U F(%)	D F(%)	SD F(%)	Mean	Remark
1.	No change in climatic condition has been observed in the past 3 years (N)	30 (12.6)	18(7.5)	13 (5.5)	107 (44.8)	71 (29.7)	4.00	Disagree
2.	Men and women are equally vulnerable to climate change (N)	39 (16.3)	120 (50.2)	64 (26.7)	12(5.0)	4(1.7)	2.82	Undecided
3.	Protection of the environment and biodiversity is impossible in the face of climate change (N)	19 (7.9)	53 (22.2)	53 (22.2)	81 (33.9)	33 (13.8)	3.59	Agree
4.	Increasing temperatures tend to reduce the number of work hours and, consequently, productivity (P)	63 (26.4)	130 (54.4)	16 (6.7)	22(9.2)	8(3.3)	4.27	Agree
5.	Planting improved varieties can help boost yield (P)	62 (25.9)	133 (55.6)	23 (9.6)	13(5.4)	8(3.3)	4.24	Agree
6.	Climate change affects income generation of households (N)	68 (28.5)	106 (44.4)	36 (15.1)	20(8.4)	9(3.8)	4.21	Agree
7.	Climate change does not affect the amount and quality of available water, wood, fish, and other natural resources (N)	10 (4.2)	28 (11.7)	42 (17.6)	80 (33.5)	79 (33.1)	4.17	Disagree
8.	Accumulation of assets has become much more difficult with climate change (P)	74 (31.0)	63 (26.4)	60 (25.1)	30 (12.6)	12 (5.0)	4.08	Agree
9.	Climate information is not a priority in planning and decision-making in rural livelihoods (N)	6(2.5)	47 (19.7)	32 (13.5)	76 (31.8)	78 (32.6)	4.08	Disagree
10.	Local knowledge reinforces scientific climate knowledge and makes it more relevant to rural livelihoods (P)	62 (25.9)	88 (36.8)	48 (20.1)	32 (13.4)	9(3.8)	4.03	Agree
11.	Climate change has no effect on the health status of households (N)	19 (7.9)	17(7.2)	31 (13.0)	115 (48.1)	57 (23.8)	4.00	Disagree
12.	No change in climatic condition has been observed in recent years (N)	30 (12.6)	18(7.5)	13 (5.5)	107 (44.8)	71 (29.7)	4.00	Disagree

(continued)

**Table 3** (continued)

S/ N	Perception statement	SA F(%)	A F(%)	U F(%)	D F(%)	SD F(%)	Mean	Remark
13.	Climate change has not reduced the quantity and quality of food consumed by households (N)	21 (8.8)	53 (22.2)	23 (9.6)	65 (27.2)	77 (32.2)	3.88	Disagree
14.	Women are more vulnerable to climate change due to their insecure access to production resources (P)	33 (13.8)	96 (40.2)	49 (20.5)	96 (40.2)	33 (13.8)	3.66	Agree
15.	Rampant bush burning in preparation for land cultivation has a negative effect on the environment (P)	44 (18.4)	100 (41.8)	48 (20.1)	36 (15.1)	11 (4.6)	3.83	Agree

Grand mean, 3.92; N, negative statement; P, positive statement

S, strongly agree; A, agree; U, undecided; D, disagree; SD, strongly disagree

Respondents disagreed that climate information is not a priority for planning in livelihoods. This is because with relevant climate information, such as weather forecast, risks can be minimized. They disagreed that climate change has no effect on the health status of rural households. Also, they disagreed with the statement that climate change has not decreased the quantity and quality of food consumed by households. This implies that climate change has affected the food security of rural households. According to CARE (2011), climate change has made rural households resort to drastic and unsustainable measures such as food rationing and borrowing. Such conditions lead to hunger, undernourishment, and poor health status which can prevent them from achieving profitable livelihoods.

However, the respondents were undecided about statement 2 which stated that men and women were equally vulnerable to climate change (mean = 2.82). This is unlike statement 14 to which respondents agreed that insecure access to production resources contributed to women's vulnerability (mean = 3.66). This may stem from their culture which still makes it difficult for them to perceive gender gaps (Antwi-Agyei et al. 2014) due to conditions such as insecure access to production resources, poor level of education, etc. These stand as barriers to women empowerment and women contributing successfully to the welfare of their households in the face of climate change. Interviews revealed that women involved in agricultural production do not get a fair bargain either as hired labor or in the sales of their produce. According to CARE (2011), this can prevent them from fulfilling their responsibilities such as providing food for their families. Also, it can serve as a barrier to learning useful skills that can aid sustainable adaptation to climate change.

A grand mean of 3.92 implies that generally respondents have a positive perception of climate change. This means they recognize its limiting tendencies (Grimberg et al. 2018). It limits the potentials of their livelihoods in generating sufficient income and the achievement of food security. It serves as an impediment to the achievement of a vibrant rural sector which can contribute meaningfully to poverty eradication and national development. Interviews with key informants revealed extensive and effective contact with agricultural extension. Therefore, agricultural extension services can leverage on their positive perception to provide enlightenment for the protection of the ecosystem. This will discourage bush burning and loss of biodiversity through intensive hunting of unique plant and animal species. Agroforestry can also be encouraged as a viable option to building resilient livelihoods.

## **Relationship Between Perception and Coping Strategies of Respondents**

A chi-square test of independence between respondents' perception of climate change and their choice of coping and adaptation strategies was carried out to determine if there is relationship between the two variables. The determinants of adaptive capacity among rural households are better assessed at household level to provide pragmatic and empirical evidence since adaptive capacity can vary

dramatically between individuals, households, and communities (Osumanu et al. 2017). Table 4 shows the chi-square result of the relationship between perception and the coping and adaptation strategies of the households.

Table 4 shows that there was a significant relationship between respondents' perception of climate change and mixed cropping ( $\chi^2 = 55.433$ ,  $p = 0.042$ ). This implies that respondents' perception of climate change influences the choice of mixed cropping as an adaptation strategy. Thus, their perception encourages the use of mixed cropping as an adaptation option which may be the reason for about 45.2% of the households choosing this strategy. Moreover, mixed cropping comes at little or no cost to the households and minimizes risk of total crop failure.

There was a significant relationship between respondents' perception and planting of improved varieties ( $\chi^2 = 55.866$ ,  $p = 0.031$ ). This implies that their perception encouraged the choice of planting improved varieties which are less sensitive to climate change in order to improve their yield. This may be as a result of the impact of agricultural extension in the study area to give advice in order to build the resilience of livelihoods, especially agricultural production.

There was also a significant relationship between respondents' perception of climate change and change in harvest dates ( $\chi^2 = 56.753$ ,  $p = 0.026$ ). Respondents' perception is, therefore, associated with the choice of harvest date which may be as a result of access to climate information or based on personal experiences. Planting new crop varieties, according to Alam et al. (2017), is an important strategy in climate change adaptation among rural households. The authors also stated that

**Table 4** Chi-square results – the role of perception in the choice of coping and adaptation strategies among rural households

Coping and strategies	$\chi^2$	df	p-value
Mixed cropping	55.433	39	0.042 <sup>a</sup>
Change in sowing date	36.787	38	0.525
Livelihood diversification	48.145	38	0.125
Sale of assets, e.g., livestock	47.561	38	0.138
Planting of improved varieties	55.866	38	0.031 <sup>a</sup>
Irrigation	32.708	38	0.712
Afforestation	42.498	38	0.283
Seasonal migration	37.744	38	0.481
Change in harvest date	56.753	38	0.026 <sup>a</sup>
Borrowing	50.915	38	0.078
Fuel conservation	42.140	38	0.296
Minimum tillage	43.473	38	0.250
Use of organic manure	38.650	38	0.440
Increased watering of soil	34.873	37	0.569
Increased watering of plants and livestock	40.807	37	0.307
Construction of barriers and drainage channels	31.591	37	0.720
Purchasing extra feed for livestock during dry season	34.155	36	0.557

<sup>a</sup>Significant at  $p \leq 0.05$

perception and local knowledge contribute to the decision of choice of harvest date of crops to prevent yield loss occasioned by climate hazards.

The result shows that rural households would utilize innovative, available, and affordable sustainable adaptation strategies based on information that educates them on their benefits, thereby modifying or changing their perception. This is corroborated by Osumanu et al. (2017) that the determinants of local adaptive capacity, like household-level adaptive capacity, include their asset base, institutions and entitlements available in the community, the knowledge and information available to them, innovation, and flexible decision-making. These allow for the adoption of sustainable adaptation strategies that help build more resilient livelihoods.

---

## Conclusion

Rural households employ diverse coping and adaptation strategies in response to climate change impacts on their livelihoods. Although their perception of climate change was favorable and indicated their understanding of its negative effects on their livelihoods, it did not take cognizance of women's insecure access to production resources. While some of the adaptation strategies, such as borrowing and sale of assets, are unsustainable, others, such as adjusting harvest and sowing dates, can be better facilitated by utilizing media to obtain weather forecasts in making planning decisions.

Government can partner with the communities and nongovernmental organizations (NGOs) in the development of early warning systems and easily accessible weather forecast in simple language. Effort should also be made in the establishment of irrigation technology in rural communities in order to reduce the drudgery of fetching water. This will boost food security and income generation among rural households. Government policies that will build the capacity of agricultural extension in providing information on crop choices and agroforestry activities should be implemented.

Women's access to production resources can be improved through policies that encourage greater gender inclusion in credit facilitation targeted at rural livelihoods. NGOs can target the erosion of institutional barriers to women empowerment by educating rural households on its implications for the rural economy and national development. Such training should also incorporate biodiversity protection. This is crucial to ending and reversing the effects of the dangers of harmful and ineffective practices on the environment. Agricultural extension can enlist the help of opinion leaders in the communities to drive the change in belief systems so as to promote the implementation of sustainable adaptation strategies.

---

## References

- Abdulai A, Ziemah M, Akaabre P (2017) Climate change and rural livelihoods in the Lawra District of Ghana. A qualitative based study. *Eur Sci J* 13(11):160–182



- Agyei F (2016) Sustainability of climate change adaptation strategies: experiences from Eastern Ghana. *Environ Manag Sustain Dev* 5(2):84–103
- Akinbami C, Ifeanyi-Obi C, Appiah D, Kabo-Bah A (2016) Towards sustainable adaptation to climate change: the role of indigenous knowledge in Nigeria and Ghana. *Afr J Sustain Dev* 6(2). Available <http://www.ajol.info/index.php/ajsd/article>
- Alam G, Alam K, Mushtaq S (2017) Climate change perceptions and local adaptation strategies of hazard-prone rural households in Bangladesh. *Clim Risk Manag* 17:52–63. Available <http://www.sciencedirect.com/science/article/pii/S221209631730013X/>
- Antwi-Agyei P, Dougill A, Stringer L (2014) Barriers to climate change adaptation: evidence from Northeast Ghana in the context of a systematic literature review. *Clim Dev* 7(4):297–309
- Apurba K, Haque C (2017) Multi-dimensional coping and adaptation strategies of small-scale fishing communities of Bangladesh to climate change-induced stressors. *Int J Clim Change Strateg Manag* 9(4):446–448
- Asrat P, Simane B (2018) Farmers' perception of climate change and adaptation strategies in Dabus Watershed, North-west Ethiopia. *Ecol Process* 7(7). Available <https://ecologicalprocesses.springeropen.com/articles/10.1186/>
- Bhatasara S, Nyamwanza A (2017) Sustainability: a missing dimension in climate change discourse in Africa? *J Integr Environ Sci* 15(1):83–97
- Cooperative for Assistance and Relief Everywhere (2011) Understanding vulnerability to climate change: insights from application of CARE's climate vulnerability and capacity and analysis (CVCH) methodology. Available <http://www.careclimatechange.org/files/adaptation>
- Faleyimu O, Akinyemi O, Agbeja B (2010) Incentives for forestry development in the South-west Nigeria. *Afr J Gen Agric* 6(2):67–76
- Food and Agriculture Organization (2003) Enhancing support for sustainable livelihoods. Committee on agriculture. 17th session. Item 7 on provisional agenda. Available <http://www.fao.org/>
- Food and Agriculture Organization (2008) Climate change and food security: a framework document. Available <http://www.fao.org/forestry/15538>
- Galotti K (1994) Cognitive psychology in and out of the laboratory. Available <http://www.sagepub.com/sites>
- Gebre GG, Isoda H, Rahut DB, Amekawa Y, Nomura H (2019) Gender differences in agricultural productivity: evidence from maize farm households in Southern Ethiopia. *Geojournal*. <https://doi.org/10.1007/s1070801910098y>
- Grimberg B, Ahmed S, Colter E, Zachariah M, Mellaned F (2018) Climate change perceptions and observations of agricultural stakeholders in the Northern Great Plains. *Sustainability* 10. Available <http://www.mdpi.com/journal/sustainability>
- IPCC (2007) Climate change 2007: impacts, adaptation and vulnerability. Contribution of working group II to the 4th assessment report of the IPCC. Cambridge University Press, Cambridge
- Jones L, Ludi E, Jeans H, Barihaihi M (2017) Revisiting the local adaptive capacity framework: learning from a research and programming framework in Africa. *Clim Dev* 7(4):1–11
- Loison S (2015) Rural livelihood diversification in Sub-Saharan Africa: a literature review 51(9). Available <http://www.tandfonline.com/loi/fjds20>
- Maddison (2007) The Perception of and Adaptation to Climate Change in Africa. Policy Research Working Paper 4308. WPS4308. The World Bank, Development Research Group, Sustainable Rural and Urban Development Team pp 3–15
- Mcdonald S (2012) Perception: a concept analysis. Available <http://www.researchgate.net/publication/>
- Moser S, Ekstrom J (2010) A framework to diagnose climate change adaptation. *Proc Natl Acad Sci* 107(51):22026–22031
- National Population Commission (2006) Population and housing census. Data for national planning. <https://www.jstor.org/stable/25434601/> Vol. 33 No.1 pp206210
- Ndamani F, Watanabe T (2015) Farmers' perceptions about adaptation practices to climate change and barriers to adaptation: a micro-level study in Ghana. *Water* 7:4593–4604
- Olajide O, Akinlabi B, Tijani A (2012) Agriculture resource and economic growth in Nigeria. *Eur Sci J* 8(22):103–116

- Omonona BT (2009) Quantitative analysis of rural poverty in Nigeria. International Food Policy Research Institution. nssp17.pdf
- Osumanu I, Anaiah P, Yelfaanibe A (2017) Determinants of adaptive capacity to climate change among smallholder rural households in the Bongo District, Ghana. *Ghana J Dev Stud* 14(2):141–163
- Oyinloye R, Oloukoi J (2013) An assessment of the Pull between Landuse and Landcover in Southwestern Nigeria and the Ensuing Environmental Impact. International Federation of Surveyors (FIG) Working Week 2013. Environment for sustainability. Held at Abuja, 2013
- Yaro J (2006) Is reagrarisation real? A study of livelihood activities in rural northern Ghana. *J Mod Afr Stud* 44(1):125–156
- Zoundji G, Witteveen L, Vodouhe S, Lie R (2017) When baobab flowers and rainmakers define the season: farmers' perceptions and adaptation strategies. *Int J Plant Animal Environ Sci* 7(2). Available <http://www.ijpaes.com/admin/php/>

**Open Access** This chapter is licensed under the terms of the Creative Commons Attribution 4.0 International License (<http://creativecommons.org/licenses/by/4.0/>), which permits use, sharing, adaptation, distribution and reproduction in any medium or format, as long as you give appropriate credit to the original author(s) and the source, provide a link to the Creative Commons license and indicate if changes were made.

The images or other third party material in this chapter are included in the chapter's Creative Commons license, unless indicated otherwise in a credit line to the material. If material is not included in the chapter's Creative Commons license and your intended use is not permitted by statutory regulation or exceeds the permitted use, you will need to obtain permission directly from the copyright holder.





# Bioeconomy as Climate Action: How Ready Are African Countries?

# 122

Oluwaseun James Oguntuase and Oluwatosin Benedict Adu

## Contents

Introduction .....	2520
Bioeconomy as Climate Action .....	2521
Current State of Bioeconomy in Africa .....	2523
Production Determinants in a Bioeconomy .....	2523
Building a Bioeconomy Readiness Index .....	2524
The State of Bioeconomy Production Determinants in African and Selected Countries .....	2525
Bioeconomy Readiness of African and Other Selected Countries .....	2528
Conclusions .....	2529
References .....	2530

## Abstract

Bioeconomy is a new perspective for fighting climate change. Africa is warming faster than the global average, and climate change remains a major threat on the continent for coming decades. The development of sustainable bioeconomy is extremely important in Africa to accelerate mitigation and adaptation to climate change. However, this concept is not well diffused on the continent. The objective

This chapter was previously published non-open access with exclusive rights reserved by the Publisher. It has been changed retrospectively to open access under a CC BY 4.0 license and the copyright holder is “The Author(s)”. For further details, please see the license information at the end of the chapter.

O. J. Oguntuase (✉)

Zenith Bank PLC, Lagos, Nigeria

Centre for Environmental Studies and Sustainable Development, Lagos State University, Lagos, Nigeria

e-mail: [oluwaseunoguntuase@gmail.com](mailto:oluwaseunoguntuase@gmail.com)

O. B. Adu

Department of Biochemistry, Lagos State University, Lagos, Nigeria

e-mail: [oluwatosin.adu@lasu.edu.ng](mailto:oluwatosin.adu@lasu.edu.ng)

© The Author(s) 2021

W. Leal Filho et al. (eds.), *African Handbook of Climate Change Adaptation*, [https://doi.org/10.1007/978-3-030-45106-6\\_82](https://doi.org/10.1007/978-3-030-45106-6_82)

2519

of this chapter is to present the current state of bioeconomy in Africa and the readiness of the member countries to adopt bioeconomy as climate action, with particular attention to the state of production determinants of a bioeconomy. The main factors and trends (both positive and negative), relating to building strategic capacity towards employing bioeconomy for climate action on the continent, are outlined. The findings and recommendations will assist both the academia and policymakers in Africa to integrate bioeconomy into their national and regional climate change mitigation and adaptation strategies and action plans.

---

**Keywords**

Climate change · Climate action · Bioeconomy · Production determinants · Africa

---

## Introduction

Africa is one of the hotspots of vulnerability to the adverse impacts of human-induced climate change (IPCC 2014), with multiple biophysical, political, and socioeconomic stresses interacting to increase the continent's susceptibility and constrain its adaptive capacity (Connolly-Boutin and Smit 2016). Productivity in several African countries depend on natural resources, climate sensitive sectors such as agriculture, fisheries, forestry, and tourism, and climate-sensitive infrastructure such as houses, buildings, municipal services, and transportation networks. Endemic poverty, lack of awareness, and lack of access to knowledge also limit the continent's adaptive capacity to cope with climate change impacts (Fereja 2017; Ford et al. 2015). With increasing temperature, the Food and Agricultural Organization (2019) projected that there will be loss of 2–7% of GDP by 2100 in parts of sub-Sahara Africa, 2–4% and 0.4–1.3% in west and central Africa, and northern and southern Africa, respectively.

Bioeconomy is a set of economic activities, an alternative to our present fossil-dependent model, in which renewable biological resources are sustainably produced to replace fossil fuels in various forms of consumption and production, to produce products (goods and services) for final and intermediate consumption. As a new wave of economic system, bioeconomy combines, in a synergic way, both natural resources and technologies, with markets, people and policies to tackle societal challenges such as natural resource scarcity, fossil resource dependence, climate change, unprecedented waste generation, loss of biodiversity, and food and energy insecurity while achieving sustainable growth.

While the concept of bioeconomy emerged in the twentieth century, it was not until the twenty-first century that it gained wide attention of scientists and policy makers as a political-economic concept which proposes the replacement of fossil resources in order to combat climate change (Asada and Stern 2018). However, bioeconomy has not been adopted by several African countries (Oguntuase 2017).

Accordingly, the objectives of this chapter are to present the current state of bioeconomy in Africa, and the readiness of African countries to embrace bioeconomy as climate action. The chapter will also compare the readiness of African countries to embrace bioeconomy with that of countries having bioeconomy strategies.

---

## Bioeconomy as Climate Action

Bioeconomy has been identified as an opportunity to achieve EU's climate change mitigation targets and reduce dependence on fossil-derived resources (Fehrenback et al. 2017). It also holds significant promise for solving the climate-related problems associated with fossil fuel use in heat, electricity, and transportation fuel production (Banerjee et al. 2018). Likewise, the use of bioenergy, devising smart strategies and value-chain pathways to lock the chain's greenhouse gases emissions, have been identified as a potential means of achieving the ambitious Paris climate target (Honegger and Reiner 2018).

Bang et al. (2009) estimated that industrial biotechnology, biofuels and bioenergy could reduce global greenhouse gas emissions by 1.0–2.5 billion tons of carbon dioxide (CO<sub>2</sub>) per year by 2030. The reduction of GHG emissions and reduction in fossil depletion impact by biorefineries was also alluded to by Gnansounou et al. (2015). Similarly, Junqueira et al. (2017) showed that both first generation 1G (in the medium and long term) and second generation 2G ethanol can reduce climate change impacts by more than 80% when compared to gasoline, while Baral and Guha (2004) reported that growing short-rotation woody crops (SRWC) for use in cost-effective biomass-based technologies such as biomass-integrated gasifier/steam-injected gas turbine (BIG/STIG) is a cost-effective strategy to combat climate change.

In other studies, Jørgensen et al. (2015) reported that temporary carbon storage in biomaterials has a potential for contributing to avoid or postpone the crossing of critical climatic target level of 450 ppm; Shen et al. (2012) found that bio-based PET (polyethylene terephthalate) polymer has been found to have the lowest greenhouse gas (GHG) emissions, compared to recycled (partially) bio-based PET, recycled PET, and petrochemical PET; Singh and Strong (2016) demonstrated that biofertilizers improve the activity of methane-oxidizing methanotrophs, thereby enhancing methane oxidation and/or decreasing the production of methane – a most potent greenhouse gas.

Beyond climate change mitigation, there is a large potential for synergies between bioeconomy and climate change adaptation. Climate change is affecting all four dimensions of food security: food availability, food accessibility, food utilization, and food systems stability (FAO 2008), and bioeconomy offers opportunities for the agriculture sector to adapt. Bioeconomy will help improve food security and advance human development through the development of more efficient systems of agricultural production which can significantly increase the production of much healthier and more natural products, compared with the products obtained by intensive modern

agriculture (Canja et al. 2017), support crop and animal diversification to produce a variety of foods suitable for health and nutrition (Bazgă and Diaconu 2013), thereby increasing the sustainability of the agricultural sector (Baidala 2016). Specifically, adoption of genetically modified (GM) technologies could help offset the detrimental effects of climate change (Ortiz-Bobea and Tack 2018) by helping to meet targeted yields, nutritional quality, and sustainable production to stabilize and increase food supplies, which is important against the background of increasing food demand in a warming resource-constrained world (Oliver 2014; Qaim and Kouser 2013).

Around 50% of harvest losses caused by environmental factors are down to drought, and it is expected that this proportion will continue to rise as a result of climate change (Linster et al. 2015), because drought stress tolerance of crops was a significant trigger for total yield in the last decades and its significance for yield is supposed to even increase in the future as a result of climate change (Lobell et al. 2014; D'Hondt et al. 2015). Genetically modified (GM) crops have been cultivated to be more resistant to drought and other biotic and abiotic stresses, increase yields by 6–30% on the same amount of land, help produce more crops per drop of water, help transition towards soil conserving farm practices such as low- and no-till systems, which are important for more efficient water use by better trapping soil moisture, and reduce greenhouse gas emissions associated with the application of fertilizers, fuel use, and plowing (ISAAA 2014; Parisi et al. 2016; Svitashhev et al. 2016; Fedoroff et al. 2010).

Employing bioeconomy in the forest-based sector has been demonstrated as both climate change adaptation and mitigation methods. Lindner et al. (2017) submitted that while developing a forest-based bioeconomy with more intensive use of forest biomass can support climate change mitigation, active replacement of maladapted species will strengthen adaptive capacity. Kalnbalkite et al. (2017) submitted that products which are produced from wood take important place in the influence on climate change reduction, while Leskinen et al. (2018) found that for each ton of carbon (C) in wood products that substitute non-wood products, average emission are reduced by approximately 1.2 ton C. This corresponds to about 2.2 ton of CO<sub>2</sub> emissions reduction per ton of wood product, depending on the wood product and technology considered, and the method used to estimate emissions.

Buildings and construction related CO<sub>2</sub> emissions have continued to rise by around 1% per year since 2010, to account for 36% of global final energy use and 39% of energy-related carbon dioxide (CO<sub>2</sub>) emissions, when upstream power generation is included; these are significant causes of climate change (IEA 2017). Life cycle assessment (LCA) of the climate impact of buildings by Peñaloza and Falk (2016) showed that increasing the biobased material content in a building reduces its climate impact even if biogenic exchanges are assessed. A similar study by Pittau et al. (2018) expressed that storing carbon in biogenic construction products and building components can largely contribute to reducing carbon emissions. In another study, Lei et al. (2016) recommend the use of phase change materials (PCMs) in tropical climates to reduce building cooling load and improve energy performance.

**Table 1** Bioeconomy-related activities in African countries

Country	Document title	Perspective
Ghana	National Bioenergy Strategy in Ghana (2014)	Bioenergy
Kenya	Strategy for developing the Bio-Diesel Industry in Kenya (2008) National Bioprospecting Strategy (2011)	Bioenergy High tech
Mali	Renewable Energy Strategy (Strategie Nationale de Développement des Energies Renouvelables en Mali) (2006)	High tech
	Biofuel Strategy (Strategie Nationale de Développement des Biocarburants en Mali) (2009)	Bioenergy
Mauritius	Ocean Economy 2013	Blue economy
Mozambique	National Biofuel Policy and Strategy (Politica e Estrategia de Biocombustiveis (2009)	Bioenergy
Namibia	National Programme on Research Science, Technology and Innovation (2015)	Research and innovation
Nigeria	National Biotechnology Policy (2001)	Research and innovation
	Biofuel Policy and Incentives (2007)	Bioenergy
Senegal	National Biofuels Strategy (2006).	Bioenergy
	Letter of Development Policy of the Energy Sector (Lettre de politique de développement du secteur de l'énergie) (2008, 2012)	Bioenergy
South Africa	The Bio-Economy Strategy (2013)	Holistic bioeconomy development
Tanzania	National Biotechnology Policy (2010)	High tech
Uganda	The Renewable Energy Policy for Uganda (2007) National Biotechnology and Biosafety Policy (2008)	Bioenergy
	Biomass Energy Strategy Uganda (2014)	High tech

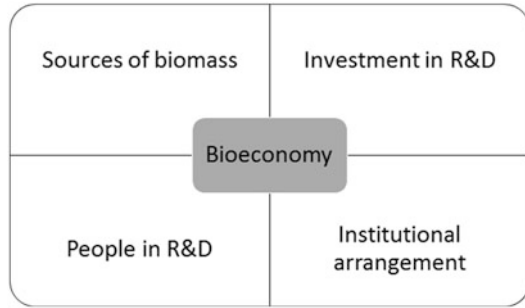
## Current State of Bioeconomy in Africa

Only South Africa has a defined bioeconomy strategy in the continent. Countries such as Ghana, Kenya, Mali, Mauritius, Mozambique, Namibia, Nigeria, Senegal, Tanzania, and Uganda have some bioeconomy-related activities as shown in Table 1.

## Production Determinants in a Bioeconomy

The epistemological understanding of production factor as a durable input employed in production activities allows for naming of new variables influencing and employed in the production processes as determinants. Having in mind the essence of bioeconomy, which is transition to low carbon sustainable economy, and the

**Fig. 1** Bioeconomy production determinants in line with classical view of production function



establishment that bioeconomy is a knowledge-based innovative economy (Lainez et al. 2018; Pyka and Prettnner 2018), it needs to be stated that the primary production determinants of the bioeconomy extends beyond those in mainstream economic theory: land, labor, and capital.

This chapter adopts the common definition that bioeconomy is “the knowledge-based production and use of biological resources to provide products, processes and services in all economic sectors within the frame of a sustainable economic system” (German Bioeconomy Council 2013). It is situated in the context that bioeconomy is a knowledge-based economy whose four primary production determinants are the sources of biomass, investment in research and development (R&D), people in research and development, and institutional arrangement. The biomasses (biological resources) are acting as substitutes for other fossil resources. Investment in R&D focuses on the development and commercialization of products and processes within the bioeconomy system. The people in R&D encompass people employed within the bioeconomy system, who have obtained sufficient knowledge to add value across the bioeconomy value chain. Institutional arrangement is connected to the organization of the system which enables implementation of solutions that ensure competitiveness under dynamic changes (Maciejczak 2015; Talavyria et al. 2016) (Fig. 1).

## Building a Bioeconomy Readiness Index

Some research findings reveal the need to measure countries’ potentials for embracing bioeconomy as climate action. Bagla and Stead (2018) developed BioGreen, a method to assess the potential of bioeconomy in curbing significant climate change and its contribution to attaining Ireland’s sustainability goals. Data from the JRC-SCAR Bioeconomy survey by the Bioeconomy Observatory showed that the need to combat climate change is one of the relevant reasons for the development of a bioeconomy in European countries (Langeveld 2015).

Mungaray-Moctezuma et al. (2015) developed the Knowledge Economy Index (KEI) which determined the necessary institutional characteristics of



technology and human capital necessary for the knowledge-based economy in Argentina, Costa Rica, and Mexico from the perspective of bioeconomy as part of the economy. In another study, Henry et al. (2017) recognized the role of scientific and technological knowledge as a key driver in a bioeconomy and highlighted the need for every country and every region to identify possibilities and opportunities in order to set its own bioeconomy development agenda, consistent with its conditions, capacities, and needs.

The Organization for Economic Co-operation and Development (OECD 2002) aggregation method is a veritable method for building indices like the one for determining the readiness of a country or jurisdiction to embrace bioeconomy as climate action. The four-step approach to the aggregated indices OECD method as adopted by Schlör et al. (2017) are: (1) the selection of the variables, (2) transformation, (3) weighting, and (4) valuation.

Specific statistical indicators for determining the bioeconomy readiness of a country or jurisdiction are virtually nonexistent at present. The most significant quantifiable indicators representing the production determinants in terms of bioeconomy are shown in Table 2.

The proposed formula for calculating the bioeconomy readiness of a country or jurisdiction is:

$$f(\text{BIOMSS, INV RD, PPL RD, IAR})$$

where: BIOMASS =  $f(\text{ARL, NBI, FOR})$

INV RD =  $f(\text{RDE, CSR, PCT, CPI, ALT, QRI, PROD})$

PPL RD =  $f(\text{ASE, RRD, TRD, QMC, UIC, SCT})$

IAR =  $f(\text{LAW, FIN, IFR, NCA})$ .

---

## The State of Bioeconomy Production Determinants in African and Selected Countries

Kenya leads African countries in the people in research and development category, performing better than Thailand and Bulgaria. Tunisia follows Kenya in this category and performed better than countries like Mexico, Costa Rica, Argentina, and South Africa, in that order. Mauritania, Lesotho, Liberia, Chad, and Congo are the worst performers as shown in Fig. 2.

An African country, Gambia, leads the biomass production determinant category. The remaining countries in the top ten are Malaysia, India, Costa Rica, Rwanda, Mexico, Sierra Leone, Malawi, Democratic Republic of Congo, and Tanzania. The poor performers are African countries – Algeria, Mauritania, Egypt, Chad, and Cabo Verde as shown in Fig. 3.

Scandinavian countries – Sweden and Finland – have invested in research and development more than other countries. South Africa is ahead of Bulgaria in investing in research and technology, while Kenya, Mauritius, Rwanda, and

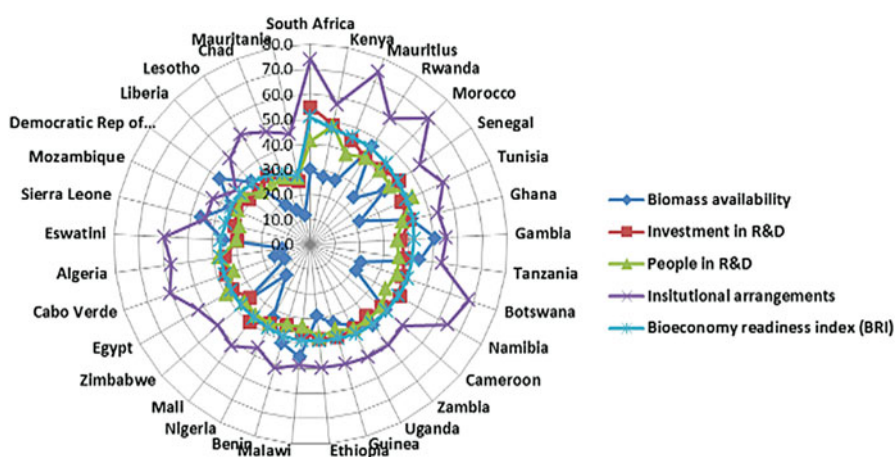
**Table 2** Possible indicators for measuring the bioeconomy readiness of a country or jurisdiction

Production determinant	Indicators	Explanation
Sources of biomass <b>BIOMASS</b>	Arable land (% of country land area), <b>ARL</b>	Includes land defined by the FAO as land under temporary crops (double-cropped areas are counted once), temporary meadows for mowing or for pasture, land under market or kitchen gardens, and land temporarily fallow
	National Biodiversity Index, <b>NBI</b>	Richness in four terrestrial vertebrate classes and vascular plants with adjustments country size
	Forest land (% of country land area), <b>FOR</b>	Forest area is land under natural or planted stands of trees of at least 5 m in situ, whether productive or not, and excludes tree stands in agricultural production systems
Investment in R&D <b>INV RD</b>	Research and development expenditure (% of GDP), <b>RDE</b>	Gross domestic expenditures on research and development (R&D), expressed as a percent of GDP
	Company spending on R&D, <b>CSR</b>	The extent companies invest in research and development
	Patents applications per million population, <b>PCT</b>	Number of applications filed under the Patent Cooperation Treaty (PCT) per million population
	Capacity for innovation, <b>CPI</b>	How do companies obtain technology; from exclusively from licensing or imitating foreign companies to conducting formal research and pioneering their own new products and processes
	Availability of latest technologies, <b>ALT</b>	To what extent are the latest technologies available
	Quality of scientific research institutions, <b>QRI</b>	Quality of scientific research institutions
	Production process sophistication, <b>PROD</b>	Sophistication of production processes
People in R&D <b>PPL RD</b>	Availability of scientists and engineers, <b>ASE</b>	Availability of scientists and engineers in the country
	Researchers in R&D per million people, <b>RRD</b>	The number of researchers engaged in Research & Development (R&D), expressed as per million
	Technicians in R&D per million people, <b>TRD</b>	The number of technicians engaged in Research & Development (R&D), expressed as per million
	Quality of mathematics and science education, <b>QMC</b>	In your country, how do you assess the quality of math and science education? [1 = extremely poor – among the worst in the world; 7 = excellent – among the best in the world]

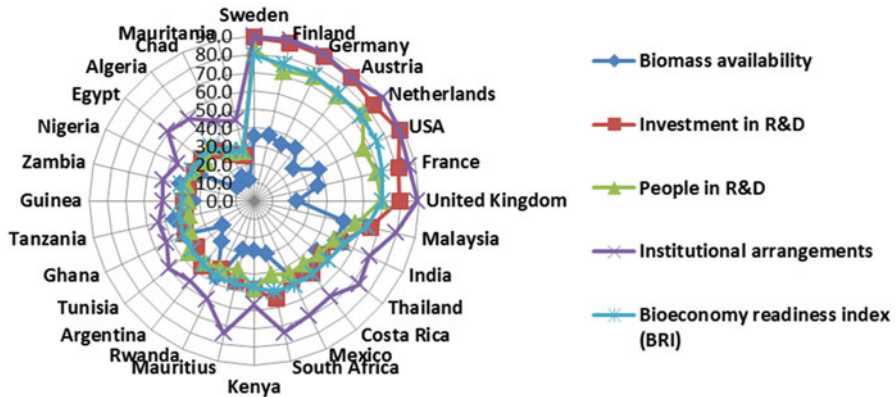
(continued)

**Table 2** (continued)

Production determinant	Indicators	Explanation
	University-industry collaboration in Research & Development, <i>UIC</i>	The extent to which business and universities collaborate on research and development (R&D)
	Scientific and technical journal articles (2003–2016), <i>SCT</i>	The number of scientific and engineering articles published in the following fields: physics, biology, chemistry, mathematics, clinical medicine, biomedical research, engineering and technology, and earth and space sciences
Institutional arrangement <i>IAR</i>	Rule of law, <i>LAW</i>	Measures countries’ rule of law performance across eight factors: constraints on government powers, absence of corruption, open government, fundamental rights, order and security, regulatory enforcement, civil justice, and criminal justice
	Availability of financial services, <i>FIN</i>	Provision of a wide variety of financial products and services to businesses
	Quality of overall infrastructure, <i>IFR</i>	Quality of overall infrastructure
	Macroeconomic stability, <i>ECON</i>	The extent to which a country’s public sector can provide appropriate counter-cyclical measures and invest in projects that the private sector cannot finance



**Fig. 2** State of bioeconomy production determinants in African countries



**Fig. 3** State of bioeconomy production determinants in selected countries

Morocco perform better than Argentina. Mauritania has the least investment in research and development, followed by Chad, Lesotho, Liberia, and Congo.

African countries perform poorly under the institutional arrangements category. The continent’s best performer, South Africa shares the same spot with Bulgaria, ahead of Argentina. Mauritania, Chad, Lesotho, and Liberia remain at the bottom of the log, just as in investment in research and development, people in research and development, and institutional arrangements production determinants.

### Bioeconomy Readiness of African and Other Selected Countries

The top African countries in terms of readiness to adopt bioeconomy as climate action are South Africa, Kenya, Mauritius, Rwanda, and Morocco as shown in Fig. 4.

The bioeconomy readiness of African countries’ compare to those of countries with bioeconomy strategies (Austria, Finland, France, Germany, Sweden, the United Kingdom, and the United States of America), and those with ongoing development strategies (Argentina, Bulgaria, Costa Rica, India, Mexico, The Netherlands, and Thailand) (Dietz et al. 2018; Sasson and Malpica 2017) as shown in Fig. 5.

Many African countries are endowed with relatively abundant natural biomass, yet they are poorly equipped to adopt bioeconomy for climate action, when compared with countries from America, Europe, and Asia. This is mainly due to the poor state of investment in R&D and dearth of people in R&D. Poor government spending on R&D, lack of patent applications, dearth of researchers and technicians in R&D, absence of latest technologies, poor industrial production process, poor university-industry collaboration, and poor institutional arrangements, especially rule of law and quality of infrastructure, are the key challenges to bioeconomy’s development on the continent.

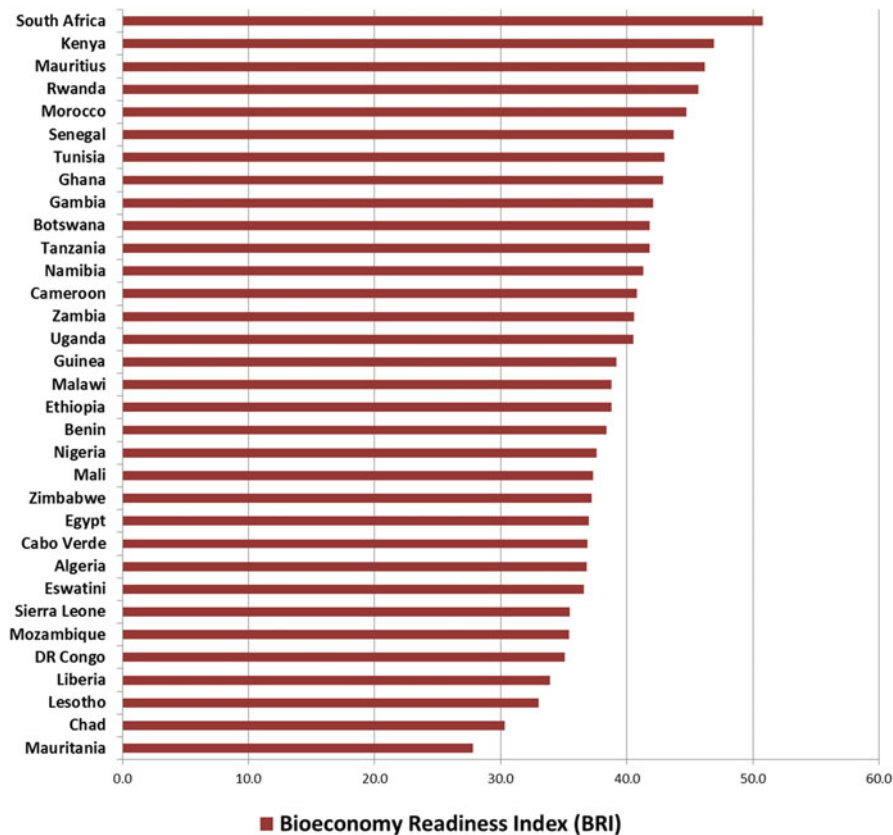
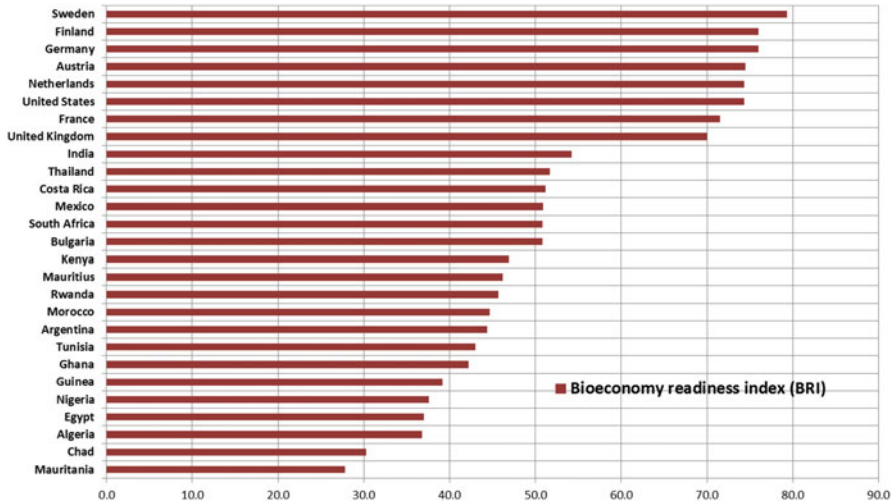


Fig. 4 African countries’ bioeconomy readiness

## Conclusions

This chapter presents the concept of bioeconomy as a knowledge economy with four production determinants: the sources of biomass, investment in research and development, people in research and development, and institutional arrangement. It introduces the bioeconomy readiness index (BRI) to determine the state of the production determinants of bioeconomy in African countries and other selected countries. Theoretically, countries with higher and better BRI will be better able to employ bioeconomy as climate action.

While there are bioeconomy-related activities in some African countries, it is significant to note that South Africa, the only country with defined bioeconomy strategy in Africa, has the best bioeconomy readiness index (BRI) on the continent. The possible policy implication of this is that formulating a dedicated national bioeconomy strategy, an integral part of national development agenda as applicable in South Africa, will help



**Fig. 5** Bioeconomy readiness of selected countries

improve the state of bioeconomy production determinants in Africa thereby increasing the continent's potential to employ bioeconomy as climate action.

Strategies to promote the bioeconomy in Africa must focus on targeted investments to support R&D activities; building efficient innovation system; improving the level of education, training, and skills of the populace; and supporting market development to enhance competitiveness. Furthermore, African countries must improve general governance, the quality of their infrastructure, and the rule of law, to attract foreign investment in the bioeconomy sectors.

While this chapter shows important findings on the state of bioeconomy in Africa and the readiness of African countries to adopt bioeconomy as climate action, further studies are recommended in the specific areas of each production determinants to shape public policy decisions towards development of sustainable bioeconomy on the continent.

Incomplete datasets and nonavailability of comparable data remains major limitations in Africa underscores the urgent need to develop and sustain a data collection and management system on the continent to overcome the challenge of dearth of data in the bioeconomy system and related sectors. In the absence of quality data, it is difficult to formulate good strategies and scale up innovations for sustainable bioeconomy on the continent.

## References

- Asada R, Stern T (2018) Competitive bioeconomy? Comparing bio-based and non-bio-based primary sectors of the world. *Ecol Econ* 149:120–128. <https://doi.org/10.1016/j.ecolecon.2018.03.014>
- Bagla A, Stead D (2018) BioGreen: bioeconomy for the future. *J Student Res* 7(1):35–44

- Baidala V (2016) Impact of the bioeconomy on food security in Ukraine. *Agric Resource Econ Int Scientific E-J* 2(3):48–59
- Banerjee A, Schelly CL, Halvorsen KE (2018) Constructing a sustainable bioeconomy: multi-scalar perceptions of sustainability. In: Leal Filho W, Pocioválișteanu D, Borges de Brito P, Borges de Lima I (eds) *Towards a sustainable bioeconomy: principles, challenges and perspectives*, World sustainability series. Springer, Cham, pp 355–374. [https://doi.org/10.1007/978-3-319-73028-8\\_19](https://doi.org/10.1007/978-3-319-73028-8_19)
- Bang JK, Follér A, Buttazzoni M (2009) Industrial biotechnology: more than green fuel in a dirty economy? Exploring the transformational potential of industrial biotechnology on the way to a green economy. World Wildlife Fund (WWF), Copenhagen
- Baral A, Guha GS (2004) Trees for carbon sequestration or fossil fuel substitution: the issue of cost vs. carbon benefit. *Biomass Bioenergy* 27(1):41–55. <https://doi.org/10.1016/j.biombioe.2003.11.004>
- Bazgă B, Diaconu A (2013) Bioeconomy – component of food security. *Metalurgia Int* 18(7):15
- Canja CM, Boeriu AE, Măzărel A (2017) Bioeconomy and food safety. In: Szeidel G, Pappalettere C, Bratu P (Chairs) *The 7<sup>th</sup> international conference on computational mechanics and virtual engineering*, Brasov COMEC 2017, Brasov, pp 35–39
- Connolly-Boutin L, Smit B (2016) Climate change, food security, and livelihoods in sub-Saharan Africa. *Reg Environ Chang* 16:385–399. <https://doi.org/10.1007/s10113-015-0761-x>
- D’Hondt K, Jiménez-Sánchez G, Philp J (2015) Reconciling food and industrial needs for an Asian bioeconomy: the enabling power of genomics and biotechnology. *Asian Biotechnol Dev Rev* 17(2):85–130
- Dietz T, Börner J, Förster JJ, von Braun J (2018) Governance of the bioeconomy: a global comparative study of national bioeconomy strategies. *Sustainability* 10:3190. <https://doi.org/10.3390/su10093190>
- FAO (2008) *Climate change and food security: a framework document*. Food and Agriculture Organization, Rome
- Fedoroff NV, Battisti DS, Beachy RN, Cooper PJ, Fischhoff DA, Hodges CN et al (2010) Radically rethinking agriculture for the 21st century. *Science* 327(5967):833–834
- Fehrenback H, Köppen S, Kauertz B, Detzel A, Wellenreuther F, Brietmayer E et al (2017) Biomass cascades: increasing resource efficiency by cascading use of biomass – from theory to practice. German Environmental Agency, Heidelberg
- Fereja GB (2017) The effect of climate change in rangeland and biodiversity: a review. *Int J Res-GRANTHAAALAYAH* 5(1):172–182. <https://doi.org/10.5281/zenodo.260396>
- Ford JD, Berrang-Ford L, Bunce A, McKay C, Irwin M, Pearce T (2015) The status of climate change adaptation in Africa and Asia. *Reg Environ Chang* 15:801–814. <https://doi.org/10.1007/s10113-014-0648-2>
- German Bioeconomy Council (2013) *Bioeconomy policy synopsis and analysis of strategies in the G7 government*. German Bioeconomy Council, Berlin
- Gnansounou E, Vaskan P, Pachón ER (2015) Comparative techno-economic assessment and LCA of selected integrated sugarcane-based biorefineries. *Bioresour Technol* 196:364–375. <https://doi.org/10.1016/j.biortech.2015.07.072>
- Henry G, Hodson E, Aramendis R, Trigo E, Rankin S (2017) *Bioeconomy: an engine for integral development of Colombia*. International Center for Tropical Agriculture (CIAT), Cali
- Honegger M, Reiner D (2018) The political economy of negative emissions technologies: consequences for international policy design. *Clim Pol* 18:306–321
- IEA (2017) *Towards a zero-emission, efficient, and resilient buildings and construction sector: global status report 2017*. International Energy Agency, Paris
- IPCC (2014) *Climate change 2014: impacts, adaptation and vulnerability. Contribution of working group II to the fifth assessment report of the intergovernmental panel on climate change*. Cambridge University Press, Cambridge
- ISAAA (2014) *Global status of commercialized biotech/GM crops: 2014*. ISAAA brief no.49. The International Service for the Acquisition of Agri-biotech Applications. Ithaca

- Jørgensen SV, Hauschild MZ, Nielsen PH (2015) The potential contribution to climate change mitigation from temporary carbon storage in biomaterials. *Int J Life Cycle Assess* 20(4):451–462. <https://doi.org/10.1007/s11367-015-0845-3>
- Junqueira TL, Chagas MF, Gouveia VLR, Rezende MCAF, Watanabe MDB, Jesus CDF et al (2017) Techno-economic analysis and climate change impacts of sugarcane biorefineries considering different time horizons. *Biotechnol Biofuels* 10:50. <https://doi.org/10.1186/s13068-017-0722-3>
- Kalnalkite A, Zihare L, Blumberga D (2017) Methodology for estimation of carbon dioxide storage in bioproducts. *Energy Procedia* 128:533–538
- Lainez M, González JM, Aguilar A, Vela C (2018) Spanish strategy on bioeconomy: towards a knowledge based sustainable innovation. *New Biotechnol* 40:87–95. <https://doi.org/10.1016/j.nbt.2017.05.006>
- Langeveld JWA (2015) Results of the JRC-SCAR bioeconomy survey. Biomass Research, Wageningen
- Lei J, Yang J, Yang E (2016) Energy performance of building envelopes integrated with phase change materials for cooling load reduction in tropical Singapore. *Appl Energy* 162:207–217. <https://doi.org/10.1016/j.apenergy.2015.10.031>
- Leskinen P, Cardellini G, González-García S, Hurmekiski E, Sathre R, Seppälä J et al (2018) Substitution effects of wood-based products in climate change mitigation. From science to policy 7. European Forest Institute, Joensuu
- Linder M, Hanewinkel M, Nabuurs G (2017) How can a forest-based bioeconomy contribute to climate change adaptation and mitigation? In: Winkel G (ed) *Towards a sustainable European forest-based bioeconomy: assessment and the way forward*. European Forest Institute, Joensuu
- Linster E, Stephan I, Bienvenu WV, Maple-Grødem J, Myklebust LM, Huber M et al (2015) Down regulation of N-terminal acetylation triggers ABA-mediated drought responses in Arabidopsis. *Nat Commun* 6:7640. <https://doi.org/10.1038/ncomms8640>
- Lobell DB, Roberts MJ, Schlenker W, Braun N, Rejesus RM, Hammer GL (2014) Greater sensitivity to drought accompanies maize yield increase in the U.S. Midwest. *Science* 344(6183):516–519. <https://doi.org/10.1126/science.1251423>
- Maciejczak M (2015) What are production determinants of bioeconomy? *Scientific Journal Warsaw University of Life Sciences – SGGW Problems of World Agriculture* 15 (XXX), 4:137–146
- Mungaray-Moctezuma AB, Perez-Nunez SM, Lopez-Leyva S (2015) Knowledge-based economy in Argentina, Costa Rica and Mexico: a comparative analysis from the bio-economy perspective. *Manag Dyn Knowl Econ* 3(2):213–236
- OECD (2002) *Aggregated environmental indices: review of aggregation methodologies in use. Contribution of working group on environmental information and outlooks*. Organisation for Economic Co-operation and Development, Paris
- Oguntuase OJ (2017) Bioeconomy for sustainable development in Nigeria: lessons from international experiences. *J Res Rev Sci* 4:97–104
- Oliver MJ (2014) Why we need GMO crops in agriculture. *Mo Med* 111(6):492–507
- Ortiz-Bobea A, Tack J (2018) Is another genetic revolution needed to offset climate change impacts for US maize yields? *Environ Res Lett* 13:124009. <https://doi.org/10.1088/1748-9326/aae9b8>
- Parisi C, Tillie P, Rodriguez-Cerezo E (2016) The global pipeline of GM crops out to 2020. *Nat Biotechnol* 34:31–36
- Peñaloza D, Falk A (2016) Exploring the climate impact effects of increased use of biobased materials in building. *Constr Build Mater* 125:219–226. <https://doi.org/10.1016/j.conbuildmat.2016.08.041>
- Pittau F, Krause F, Lumia G, Habert G (2018) Fast-growing bio-based materials as an opportunity for storing carbon in exterior walls. *Build Environ* 129:117–129. <https://doi.org/10.1016/j.buildenv.2017.12.006>
- Pyka A, Prettnner K (2018) Economic growth, development, and innovation: the transformation towards a knowledge-based bioeconomy. In: Lewandowski I (ed) *Bioeconomy*. Springer, Cham, pp 331–342. [https://doi.org/10.1007/978-3-319-68152-8\\_11](https://doi.org/10.1007/978-3-319-68152-8_11)



- Qaim M, Kouser S (2013) Genetically modified crops and food security. *PLoS One* 8(6):e64879. <https://doi.org/10.1371/journal.pone.0064879>
- Sasson A, Malpica C (2017) Bioeconomy in Latin America. *New Biotechnol* 40(Pt A):40–45. <https://doi.org/10.1016/j.nbt.2017.07.007>
- Schlör H, Venghaus S, Hake J (2017) Green economy innovation index (GEII) – a normative innovation approach for Germany and its FEW nexus. *Energy Procedia* 142:2310–2316. <https://doi.org/10.1016/j.egypro.2017.12.159>
- Shen L, Worrell E, Patel MK (2012) Comparing life cycle energy and GHG emissions of bio-based PET, recycled PET, PLA, and man-made cellulose. *Biofuels Bioprod Biorefin* 6(6):625–639. <https://doi.org/10.1002/bbb.1368>
- Singh JS, Strong PJ (2016) Biologically derived fertilizer: a multifaceted bio-tool in methane mitigation. *Ecotoxicol Environ Saf* 124:267–276. <https://doi.org/10.1016/j.ecoenv.2015.10.018>
- Svitashev S, Schwartz C, Lenderts B, Young JK, Cigan AM (2016) Genome editing in maize directed by CRISPR–Cas9 ribonucleoprotein complexes. *Nat Commun* 7:13274. <https://doi.org/10.1038/ncomms13274>
- Talavyria MP, Lymar VV, Baidala VV, Holub RT (2016) Approaches to the definition of production determinants of bio-oriented economy. *Ekonomika APK* 7:39–44

**Open Access** This chapter is licensed under the terms of the Creative Commons Attribution 4.0 International License (<http://creativecommons.org/licenses/by/4.0/>), which permits use, sharing, adaptation, distribution and reproduction in any medium or format, as long as you give appropriate credit to the original author(s) and the source, provide a link to the Creative Commons license and indicate if changes were made.

The images or other third party material in this chapter are included in the chapter's Creative Commons license, unless indicated otherwise in a credit line to the material. If material is not included in the chapter's Creative Commons license and your intended use is not permitted by statutory regulation or exceeds the permitted use, you will need to obtain permission directly from the copyright holder.





# Flood, Livelihood Displacement, and Poverty in Nigeria: Plights of Flood Victims, 2012–2018

# 123

Joachim Chukwuma Okafor

## Contents

Introduction .....	2536
Definition of Terms .....	2537
Method and Source of Data Collection and Analysis .....	2538
Reported Cases of Deaths, Population Displacement, Damages, and Victims Impoverished by Flooding in Nigeria, 2012–2018 .....	2538
Government Responses to the Victims of Flooding and Challenges to Government Responses to the Plight of Flood Victims in Nigeria .....	2544
Conclusion and Strategic Recommendations .....	2544
References .....	2545

## Abstract

The impacts of flood on the Nigerian population over the years have been enormous. This is because the attendant associated risks such as destruction of lives and properties, livelihood displacement, and impoverishment of victims arising from increasing flood cases have constituted a threat to the citizens' survival and therefore inform the attention the menace has drawn among scholars, policy analyst. This chapter has as its primary aim, a critical assessment of the impacts of government responses over the plight of victims of flooding in Nigeria over the years under review. Thus, special attention is given in this chapter to the various barriers or challenges facing government response to the plight of flood victims in Nigeria. Finally, some valuable steps, which if taken will reduce these

This chapter was previously published non-open access with exclusive rights reserved by the Publisher. It has been changed retrospectively to open access under a CC BY 4.0 license and the copyright holder is "The Author(s)". For further details, please see the license information at the end of the chapter.

J. C. Okafor (✉)  
Department of Political Science, University of Nigeria, Nsukka, Nigeria  
e-mail: [Chukwuma.okafor@unn.edu.ng](mailto:Chukwuma.okafor@unn.edu.ng)

barriers or challenges, are outlined. Though, the study adopted the use of secondary sources of data collection via content analysis, the experiences and knowledge gathered in this chapter will be strategically useful to people and organizations interested in the government of Nigeria's response to the plight of flood victims, barriers inhibiting the success of fund utilization in reducing the suffering and impoverishment of the flood victims, number of deaths, and population displaced as a result.

---

**Keywords**

Flood · Livelihood displacement · Poverty · Government responses · Flood victims

---

**Introduction**

Now in its sixth year, the threats the 2012 flood disaster along with the subsequent flood disasters that accompanied it posed on the livelihood of the victims in relation to the protracted impoverishment and displacement that these victims suffered while awaiting the government and private led humanitarian groups on relief materials have been the subject of debate among scholars, policy analysts, and climate change mitigation and adaptation experts (Nwodim 2016). The 2012 flood disaster in Nigeria that began in early July alone killed 363 people and displaced over 2.1 million people as of November 5, 2012 (Adekola and Lamond 2018).

According to the National Emergency Management Agency (NEMA), 30 out of the 36 states were affected by the floods. The floods were termed as the worst in Nigeria history in 40 years, and affected an estimated total of seven million people (Nkwunonwo 2016). The estimated damages and losses caused by the floods were worth 2.6 trillion naira (Cirella and Iyalomhe 2018). As rightly noted by Ndujihe (2018), flood disasters which followed the devastating 2012 event have the usual trend of submerging houses, deaths of people, population displacement, washing away of farmlands, and destruction of people sources of livelihood which have implications on the growing incident of impoverishment among affected Nigerian population. In fact, the 2018 flood disaster recorded in different states in Nigeria alone, especially from Bayelsa state, has been rated as the worst in the last 6 years (Akukwe et al. 2018).

In Nigeria, different factors have been deduced which account for the incessant cases of flood disaster in the country especially in states declared as the flashpoints for flood disaster (Nkwunonwo et al. 2016; Conversation 2017). First, climate change which causes global warming has been singled out as the basic factor that accounts for the increasing cases of flood disaster which has been shown to contribute to more extreme storms and rainfall. Another factor contributing to flooding in the country is that of the increasing rapid urban growth and poor drainage/culvert system planning. This chapter has as its objective the impacts of government response over these years on the plight of the flood victims. The assessment of the successive flood disasters from 2012 to 2018 on how it undermined livelihood,

displaced population, destroyed farmlands, and foster impoverishment on the affected population. The rest of the chapter includes the introduction, definition of terms, method and sources of data collection and analysis, government response to the victims of floods in Nigeria, and protracted challenges facing the government in this regard. The reported cases of deaths, population displaced, damages and victims impoverished by flooding in Nigeria within the period under review. We draw conclusion with strategic recommendations.

---

## Definition of Terms

The concepts of flood, livelihood displacement, poverty, government response, and victims of flood are pivotal in this discourse. Hence the definition of these terms will enhance a shared understanding of their usage in this discourse.

- *Flood:*

This is the outpouring or overflowing of water usually through rainfall which covers dry space and causes devastations on the socioeconomic activities of the people. Flood can occur through outburst of dam which releases much water on the dry spaces. Recent flood disasters in Nigeria have brought about the deaths of Nigerians, the washing away or destruction of farmlands, submerging of houses which heralds population displacement. Flood can be defined as an overflow of large quantities of water onto a normally dry land. Flooding happens in many ways due to overflow of streams, rivers, lakes, or oceans or as a result of excessive rainfall. Flood or flooding also destroys crops and can wipe away trees and other important structures on land.

- *Livelihood displacement (LD):*

Livelihood implies various means through which individuals secure a living. Livelihood also involves individuals or people assets, capabilities, income, and activities required to secure a living. Livelihood displacement encompasses threats that disarticulate or disrupt the operations of livelihood. In Nigeria, like in any other parts of the world, floods or flooding has proved to be the potent threat to livelihood displacement or disruption. Natural disasters like earthquake, hurricane, and climate change could become threat to livelihood displacement. In Nigeria, the 2012 flood disaster and the successive disasters have washed away cash crops and farmlands, fish pond, poultry business economic activities where people derived their livelihood.

- *Poverty:*

The displacement of people from their means of livelihood through flooding without the provision of relief material either from the government or private sector led humanitarian agencies to cushion the devastating impacts of the displacement could exacerbate impoverishment among the victims of flooding. Poverty in this chapter means lack of capability or the capacity by the victims of flooding to provide for their basic necessities of life such as house, food, water, and healthcare, among others.

- *Government response (GR):*

This is taking to mean, assistance, and support in the forms of relief materials given to the flood victims with the intention to reduce their sufferings brought about by flood disaster. In Nigeria, National Emergency Management Agency (NEMA) oversees and supervises the delivery of these relief materials across the Nigeria. Each state in Nigeria, for administrative convenience, has their respective State Emergency Management Agency (SEMA). Part of government response to the plight of flood victims in Nigeria is the release of fund. In 2012, the government under President Good luck Jonathan released the sum of ₦17.6 billion for the support of flood victims. Under President Muhammadu Buhari, the federal government has earmarked ₦ 1.6 billion each for the following states in the wake of the 2018 flood disaster across these states. The benefiting states are: Ekiti, Osun, Akwa Ibom, Kebbi, Niger, Kwara, Ebonyi, Enugu, Abia, Oyo, Lagos, Plateau, Sokoto, Edo, and Bayelsa.

- *Flood victims (FV)*

This is taking to mean individuals, groups, households, and communities that suffered from the devastating impacts of flood disaster. In Nigeria, there is victims support fund for flood disaster. Flood victims are person or persons whose houses were submerged by floods, farmland and livestock's destroyed, and source of livelihood is undermined or disrupted by flood disaster.

---

## **Method and Source of Data Collection and Analysis**

This chapter adopted the documentary method of data collection that derived its base from the secondary sources of data gathering that include journal articles, newspapers, books, government publications, among others. The qualitative method of data analysis via content analysis was used to analyze the materials gathered from the secondary sources.

---

## **Reported Cases of Deaths, Population Displacement, Damages, and Victims Impoverished by Flooding in Nigeria, 2012–2018**

From the year 2012 to 2018, the incident of flood disasters and its associated impacts on the victims of flood has been enormous (Onwuka et al. 2015). Table 1 below covers the series of livelihood displaced, farmlands and cash crops washed away by flood, displaced people and livestock, impoverishment, and deaths, which occurred in Nigeria in some selected states. The logic behind the selection of these states was based on the declaration of the states as flashpoints or state vulnerable to flood disaster.

**Table 1** Shows reported cases of deaths, population displacement, damages and victims impoverished by flooding in Nigeria, 2012–2018

S/ No.	State	Month & year	Reported cases of deaths, displacement, damages, and impoverishments of victims by floods	Remarks
1.	Enugu	March 2018	Flood destroyed buildings, killed a brick layer and 2 students at Uhuwerre community in Igbo Eze South L.G.A in the state	The flood incident destroyed farmlands of villagers with cash crops washed away by marauding flood
2.	Ogun	June 2018	Farmers in Idagba area of Ayetoro in Yewa L.G.A recorded loss of lives and fishes worth 100 million naira to flood. Twelve persons killed, 3,800 displaced, 200 homes destroyed in Abeokuta. Areas affected in the city include: Lafenwa, Ijaiye, Kuto, Oke Lantoro, Amolaso, Kobiti, and Ilawo	The people whose source of livelihood is tied to farming have been threatened and many became internally displaced in the process
3.	Delta	July 2018	Flood submerged 63 communities, destroyed 43 houses in Koko, Warri North, Araya, Isoko South L.G.A. Agbarhor Ughelli North and Oghara communities in the state	The flood was accompanied with heavy downpour and brainstorms
4.	Niger	July 2018	Twenty-three persons were reported dead while bridges, roads, and culverts linking villages were destroyed. Two persons were allegedly missing	The flood forced many villagers out of their homes, and economic activities were severely halted
5.	Kano	August 2018	Eight local government areas in the state were affected, and hardest hit was Kiru local government area which recorded the deaths of 3 persons	Indigenes/residents of these local areas are predominantly farmers. The flood halted their livelihoods, and their movement were restricted for days thereby undermining economic activities
6.	Bayelsa	October 2018	Seventy percent of the Bayelsan communities were submerged by flood. The hardest hit was communities in Sagbama L.G.A. Many persons were displaced. These communities include	The flood disaster led to closure of schools

(continued)

**Table 1** (continued)

S/ No.	State	Month & year	Reported cases of deaths, displacement, damages, and impoverishments of victims by floods	Remarks
			Sampou, Kaiama, Bolou Orua, Toru Orua, etc.	
7.	Lagos	July 2017	Homes and buildings were submerged, movements along the roads became difficult in Lekki, Victoria Island, Ajah and other cities and towns in the state	This flood halted economic activities. Poor drainage system and inadequate urban planning were said to be force multipliers of the flood
8.	Benue	August 2017	An estimated 1,000 persons were displaced, 2,000 homes damaged and lives lost. The flood is peculiar to Benue state due to Benue river and serial heavy downpour as flashpoints state	Benue is known for consistent agricultural produce. Six Local government areas affected were Markudi, Agatu, Guma, Tarka, Logo, and Buruku
9.	Katsina	August 2017	According to the State Emergency Management Agency (SEMA), an estimated 1,000 houses were destroyed, many displaced from their homes and lives lost to flood in Inwala Jangebe village in Batagarawa, Kaita, Malumfashi, Mabai village of Kankara, and Kusada L. G.As	Majority affected by the flood were rural farmers. SEMA had distributed 2 trailers of cement and 600 bundles of roofing zinc to the flood victims across the L.G.As
10.	Imo	October 2017	The flood that occurred in Umuohii village in Oboama Autonomous community in Ezinihitte Mbaise destroyed buildings, farmlands, livestock, and economic trees	The heavy downpour that lasted for 2 days rendered 50 household homeless
11.	Oyo	June 2017	Over 3,000 houses were submerged as lives and properties were destroyed in Olodo, Oki, Akobo, Onipepeye, Kute, Eleyele, Ariyo, and Celestial Church Orogun along University of Ibadan-Ojo road in Ibadan metropolis by heavy downpour	The Oyo state government had promised to support the affected residents and repair roads, culverts, and drainages. Absence of these amenities widens the damages from flooding

(continued)

**Table 1** (continued)

S/ No.	State	Month & year	Reported cases of deaths, displacement, damages, and impoverishments of victims by floods	Remarks
13.	Nassarawa	August 2016	Fifteen persons died, 36 houses submerged, and handful scores of people missing in the flood disaster in Mararaba, Gurku, Kabayi, and Ado communities in Karu L.G.A	Nassarawa state is among the flashpoint states warned by NEMA of impending flood disaster in the beginning of the year
14.	Yobe	August 2016	The SEMA estimated that about 300 houses were destroyed; farmlands and livestock were destroyed in Jakusko and Adaya communities by the flood disaster. Other villages affected by the flood include Ngelzarma, Jajere, Nangere, Buduwa, Nguru, Gashua, Damagum, Dapchi, etc.	Agrarian Yobe state is among the frontline states that Boko Haram had caused havoc; flood disasters intensified the sufferings of the people. Food, clothes, and building materials were provided to the victims by the state government
15	Sokoto	August 2016	Fifty houses were destroyed in Bachaka village in Gudu L.G.A by flood disaster caused by early morning downpour	No loss of lives was recorded but people farmlands and crops worth millions of naira were destroyed thereby aggravated the poverty of the locals
16	Bauchi	August 2016	Four persons died of flood disaster in Galamakira and Galam Baba communities in Ganjuwa L.G.A. Eight persons killed by flooding in Gulbuk community in Giade L.G.A	Lack of access to primary health care for those who sustained injuries during the emergency in these localities was glaring
17	Plateau	August 2016	All-night downpour destroyed 20 cows by herdsmen in Fobor-Angware and Maza, houses were destroyed, people in Jos East L.G.A. Roads linking communities were also washed away by the heavy flood	Twenty-nine other cows were discovered after the flood disaster. Farmers lost their sources of livelihood as many farmlands were destroyed by the flood
18	Kano	September 2015	Six persons were killed in Shanono, Dala, Tundu Wada, Gabasawa, and Takai L.G.As by flood and 1,600 persons representing families and properties	15.8 million naira was said to have earmarked for the purchase of relief materials for the support of the victims

(continued)



**Table 1** (continued)

S/ No.	State	Month & year	Reported cases of deaths, displacement, damages, and impoverishments of victims by floods	Remarks
			worth millions were displaced by flood disaster	
19	Edo	September 2015	More than 35 communities were submerged by flood in Etsako East and Etsako Central L.G.A. An estimated 30,000 persons were displaced on the two divides, and farmlands with cash crops were destroyed by flooding. The affected communities were Udaba, Uneme, Usomegbe, Anegbette, Uneme- Ugwoyo, etc.	Victims of the flood were women and children who were in dire need of health- care facilities, foodstuff, shelter, etc.
20	Adamawa	September 2015	Seven communities in 5 local governments' areas were submerged by flood that includes Guluk, Shelligence, Lamurde, Demsa, and Numan. Borongo community was the hardest hit communities. People were displaced, and properties and farmlands were destroyed by flooding	Alleged to have caused by outburst flood water from Kiri-Dam and heavy downpour
21	Ebonyi	September 2014	Over 200 houses were submerged, families displaced by flood, and 2 persons killed as a result in Onuebonyi Inyimagu, Abakaliki, and Izzi local government area	The flood came as a result of a 3-day downpour which affected rice plantations plus other farms input. Ebonyi state is an agrarian state
22	Kaduna	September 2014	The flood claimed the life of a 7-year-old girl Theresa James at Anguwar Yelwa community in Chikun L.G. A. Other areas affected by the flood include Unguwar Rimi, Lere, Kachia, Kaduna North & South, Unguwar Dosa, Zaria council, etc.	The flood was said to have caused by 2-day heavy downpour
23	Oyo	June 2014	Ten persons were killed in Apete Ibadan when a makeshift bridge was collapsed by floodwater	Oyo state is among the flashpoints for high incident of flooding in Nigeria

(continued)

**Table 1** (continued)

S/ No.	State	Month & year	Reported cases of deaths, displacement, damages, and impoverishments of victims by floods	Remarks
24	Anambra	November 2013	An estimated 1,000 people of the 2012 flood victims lost their voter's card in Ogbaru and Anambra East L.G.A	Anambra state is one of the states in the federation declared by NEMA as the national disaster in the country
25	Kano	August 2013	Five hundred persons were displaced by heavy downpour, 100 homes submerged, 4 person missing	Kano is the largest city in northern Nigeria where torrential rainfall is fairly common and residents in rural areas rely on agriculture for their livelihood
26	Yobe	August 2013	Over 300 houses were submerged and 1,000 persons displaced by from their homes. Areas affected in the state are Potiskum, Gashu'a, Nguru, Fika, Gaidam, Damagum, and Damaturu, the state capital	The flood also destroyed farmlands and crops
27	Cross River	July 2012	49,000 people were displaced by the flood. Over 212 communities, 1,800 houses, 82,361 farmlands, 13 lives lost, 13 suffered severe injuries, 18 markets, 15 churches, and 13 schools were destroyed	Agrarian communities whose farmlands and cash crops were destroyed became vulnerable. One among the states in Nigeria affected by the 2012 unprecedented flood experience
28	Plateau	July 2012	Thirty-nine persons were killed by the flood and 35 missing. An estimated 200 homes were destroyed by the flood, and 3,000 persons were displaced	Enlisted in the club of states severely affected by the 2012 flood disaster
29	Kogi	September 2012	An estimated 623,900 persons were displaced and 152,575 hectares of farmlands were destroyed by the flood	Flashpoints of states in Nigeria that are flood vulnerable
30.	Niger	October 2012	Over 117 communities submerged by flood, 663,000 persons were affected as the victims displaced from their homes. Farmlands destroyed and cash crops uprooted by the disaster	The victims and displaced persons in the various resettlements camps in the state appealed to the government to make their stay permanent. That is the degree of frustrations experienced by these flood victims

Source: Compiled by the Author

## **Government Responses to the Victims of Flooding and Challenges to Government Responses to the Plight of Flood Victims in Nigeria**

In meeting with the increasing humanitarian needs of the flood victims, the National Emergency Management Agency (NEMA) was established via Act 12 as amended by Act 50 of 1999, to manage disasters in Nigeria. Therefore, from inception, NEMA has been tackling disaster-related issues through the establishment of concrete structures and measures, such measures as the education of the public in order to raise their level of awareness and reduce the effects of disasters in the country. In each of the 36 states including the Federal Capital Territory, there exists the State Emergency Management Agency (SEMA). From 2012 to 2018 involving the administration of President Good luck Jonathan and the current administration of President Muhammad Buhari, various emergency interventionist funds have been given to the states affected by the flood disasters. Under the former President Goodluck Jonathan, the sum of ₦17.6 billion naira was shared to states by the federal government to states hard hit by flooding. Following the rampaging floods of 2018, the federal government released ₦1.6 billion naira to 16 states that benefited from the intervention. The states are Ekiti, Osun, Akwa Ibom, Kebbi, Niger, Kwara, Ebonyi, Enugu, Abia, Oyo, Lagos, Plateau, Sokoto, Edo, and Bayelsa.

Despite federal government efforts in ameliorating the humanitarian needs of the flood victims, in 2018, the government pledged \$8.2 million for relief efforts as well as declaring a state of emergency in four states, namely, Niger, Anambra, Kogi, and Delta States. NEMA set up five emergency operation centers to facilitate search and rescue operations and humanitarian support. Orji (2018) had revealed that the various efforts and program in rescue and support for the flood victims have faced huge practical challenges in reaching flood victims; however, these efforts have also reportedly been undermined by poor management, bad governance, and corruption. Other challenges derailing the government efforts in meeting with the humanitarian needs of the floods victims is failure on the part of successive government to plan and prepare for long-term solution to the crisis of flooding in the country. People mistrust on government ability to come to their rescue in the face of national disaster and inability of the Nigerian state to judiciously implement the provisions of disaster management plan. The widening gap in the interaction between the state (Federal Government) and various Civil Society Organisations (CSO) in the country have not been cordial.

---

## **Conclusion and Strategic Recommendations**

We began the chapter with the position that the lives of the victims of floods in Nigeria from the illustrated cases in our Table 1 show that from 2012 to 2018, destruction of farmlands and cash crops, population displacement, deaths of many Nigerians and the wanton destruction of people livelihoods were devastating in Nigeria. With this, the following strategic recommendations are offered:

- Nigerian government should develop a long-term strategic plan toward the rescue, support, and release of humanitarian needs of the population. The culture of reactive from the federal government toward the plight of the floods victims should be discouraged.
- Fund so released for meeting the demands and needs of the floods victims should be monitored by the federal government to avoid rascality, misuse of funds, and diversion of the fund for personal aggrandizement of their members.
- There should be appropriate climate-related education in order to sensitize the population on risks associated with the floods.

---

## References

- Adekola O, Lamond J (2018) A media framing analysis of urban flooding in Nigeria: current narratives and implications for policy. *Reg Environ Chang* 18:1145–1159
- Akukwe TI, Krhoda GO, Oluoko-Odingo AA (2018) Floods and meal frequency: the situation in Anambra and Imo States, South-eastern region of Nigeria. *Journal of Environmental Science, Toxicology and Food Technology* 12(6):22–30
- Cirella GT, Iyalomhe FO (2018) Flooding conceptual review: sustainability-focalized best practices in Nigeria. *Appl Sci* 8(1558):2–14
- Conversation (2017) Why flooding in Nigeria is a serious problem. <https://theconversation.com/why-flooding-in-nigeria-is-an-increasingly-serious-problem-82272>
- Ndujihe C (2018) Rain of Fury: Nigeria loses 141 lives to rainstorm, flood in 2018. <https://www.vanguardngr.com/2018/08/rains-of-fury-nigeria-loses-141-lives-to-rainstorm-flood-in-2018>
- Nkwunonwo UC (2016) A review of flooding and flood risk reduction in Nigeria. *Glob J Hum Soc Sci* 16(2):22–42
- Nkwunonwo UC, Whitworth M, Baily B (2016) Review article: a review and critical analysis of the efforts towards urban flood risk management in the Lagos region of Nigeria. *Nat Hazards Earth Syst Sci* 16:349–369
- Nwodin O (2016) The 2012 flood and government policy response in the Niger Delta. *J Polit Sci Leadersh Res* 2(2):54–63
- Onwuka SU, Ikekpeazu FO, Onuoha DC (2015) Assessment of the causes of 2012 floods in Aguleri and Umuleri, Anambra East local government area of Anambra state. *Br J Environ Sci* 3(1):43–57
- Orji S (2018) It rains, it pours, and it floods: Nigeria's growing seasonal problem. *African arguments*. <https://www.africanarguments.org/2018/11/15/nigeria-floods-growing-problem>. November, 15th

**Open Access** This chapter is licensed under the terms of the Creative Commons Attribution 4.0 International License (<http://creativecommons.org/licenses/by/4.0/>), which permits use, sharing, adaptation, distribution and reproduction in any medium or format, as long as you give appropriate credit to the original author(s) and the source, provide a link to the Creative Commons license and indicate if changes were made.

The images or other third party material in this chapter are included in the chapter's Creative Commons license, unless indicated otherwise in a credit line to the material. If material is not included in the chapter's Creative Commons license and your intended use is not permitted by statutory regulation or exceeds the permitted use, you will need to obtain permission directly from the copyright holder.





# Evidence-Based Policy Development: National Adaptation Strategy and Plan of Action on Climate Change for Nigeria (NASPA-CCN)

# 124

Robert Ugochukwu Onyeneke, Chinedum Uzoma Nwajiuba,  
Brent Tegler, and Chinyere Augusta Nwajiuba

## Contents

Introduction .....	2548
Evidence-Based Policy .....	2550
Public Policy .....	2550
Policy Making .....	2551
Evidence-Based Policy Making .....	2551
Why Evidence-Based Policy Is Important .....	2551
Difference Between Evidence-Based Policy and Nonevidence-Based Policy .....	2552
Development of Evidence-Based Policy .....	2553
How Policy Makers Receive and Interpret the Outcomes of Specific Types of Research ...	2553
Sectoral Concentration of Evidence-Based Policy Making in Nigeria .....	2554
The Frame: BNRCC .....	2554
Research Component .....	2555
Pilot Projects Component .....	2556

This chapter was previously published non-open access with exclusive rights reserved by the Publisher. It has been changed retrospectively to open access under a CC BY 4.0 license and the copyright holder is “The Author(s)”. For further details, please see the license information at the end of the chapter.

R. U. Onyeneke (✉) · C. U. Nwajiuba  
Department of Agriculture (Agricultural Economics and Extension Programme),  
Alex Ekwueme Federal University Ndufu-Alike, Ikwo, Ebonyi, Nigeria  
e-mail: [robertonyeneke@yahoo.com](mailto:robertonyeneke@yahoo.com); [robert.onyeneke@funai.edu.ng](mailto:robert.onyeneke@funai.edu.ng); [chnwajiuba@yahoo.de](mailto:chnwajiuba@yahoo.de)

B. Tegler  
North-South Environment Inc., Campbellville, ON, Canada

Liana Environmental Consulting Ltd., Fergus, ON, Canada  
e-mail: [btegler@nsenvironmental.com](mailto:btegler@nsenvironmental.com)

C. A. Nwajiuba  
Educational Foundations, Alex Ekwueme Federal University Ndufu-Alike,  
Ikwo, Ebonyi, Nigeria  
e-mail: [caanwajiuba@gmail.com](mailto:caanwajiuba@gmail.com)

The NASPA-CCN .....	2558
Process of Developing the NASPA-CCN .....	2558
Methodology .....	2559
Result .....	2559
How Would You Rate the Process of Developing NASPA-CCN? .....	2559
What Do You Consider as the Key Success Factors of the NASPA-CCN Process? .....	2560
Limitations .....	2561
Conclusion .....	2561
References .....	2562

## Abstract

Evidence-based policies are recommended for the enhanced chances of efficacy in achieving policy goals. Achieving this in the policy development process may however require approaches that are not as simple especially in less developed countries, where the research-policy linkage is not commonly the case. This chapter provides a guide to a practical approach that could assist policy makers in similar societies based on the steps adopted in the development of the National Adaptation Strategy and Plan of Action on Climate Change (NASPA-CCN) for Nigeria. The NASPA-CCN has been acknowledged as among the models of climate change policy development that other countries could aim for. It is therefore positioned to offer lessons on policy development in a less developed country environment. The focus in this chapter however is not so much on the subject of climate change but the practical experiences and lessons learnt from the process involved in developing the NASPA-CCN providing lessons learned to mainstream climate change research evidence into policy.

## Keywords

Building Nigeria's Response to Climate Change (BNRCC) · Research · Community-based adaptation projects · Evidence-based policy development · Stakeholders · Perception · Resilience

## Introduction

Climate change negatively impacts sustainable development across the world (World Bank 2019). Climate change slows the developmental progress made by many nations in the world. It is widely acknowledged that climate change is global and mainly caused by human activities, but the impacts are felt differently by different continents, regions, countries, communities, and sectors (NEST and Tegler 2011; IPCC 2013, 2014a, b, c; Gagliarducci et al. 2019). For instance, Africa's contribution to the major causes of climate change is marginal, but the continent is the hardest hit by climate change impacts (Tarfa et al. 2019; Niang et al. 2014). This is largely due to the vulnerability of the continent as well as her low adaptive capacity (Onyeneke et al. 2017). These characteristics present climate change adaptation as an important response strategy to countries in Africa especially sub-Saharan Africa. In responding

to climate change in Africa, local adaptation strategies will not be sufficient, hence the need for planned adaptation to deal with climate risks (Tarfa et al. 2019). Planned adaptation strategies, which are often captured in countries adaptation action plans/programs, have been advocated all over the world. Unfortunately many action plans/programs adopted a top-down approach to their adaptation planning and are largely not informed by evidence. This is why many stakeholders advocate for evidence-informed adaptation policymaking and planning.

The impacts of climate change are evident in Nigeria and are likely to intensify in the future (BNRCC and Federal Ministry of Environment 2011; NEST and Woodley 2011) with the effects touching almost every facet of the national economy – communities, economic sectors, businesses, and governments across the country. Nigerian communities are responding to climate risks in their own ways with the limited resources available to them. The projected impacts of climate change in Nigeria are predicted to significantly worsen (Table 1).

Integrating climate change adaptation into development policies, plans, and projects is an effective approach to managing the risks and opportunities of climate change while enhancing sustainable development (BNRCC and Federal Ministry of Environment 2011). It is usually recommended that policies be evidenced based using the best available evidence to inform policy decisions (Nutley et al. 2009). This is because robust evidence is expected to provide an antidote to policy failures (Pawson 2002a, b). The main arguments for this are that evidenced-based policies have wider ownership, they stand better chances of being implemented, and they have brighter prospects of policy goals being achieved and sustained. This rather simple understanding has not been embraced in policy making, and evidence-based policies are the exception, rather than the norm. Evidence-based policymaking could be viewed as a process that rigorously and systematically employs robust and tested evidence in policy design, implementation, and evaluation (Sutcliffe and Court 2005). Head (2008) provided a nuanced description of the knowledge and evidence that characterize policy. According to Head (2008), these include political know-how, rigorous scientific and technical analysis, and practical and professional field experience.

**Table 1** Projected trends of key climate change parameters for Nigeria by ecological zone

Climate variable	Mangrove zone	Rainforest	Tall grass (Savanna)	Short grass (Sahel)
Temperature	Increasing	Increasing	Increasing	Increasing
Rainfall volume	Increasing	Increasing	Decreasing	Decreasing
Rainfall variability	Increasing	Increasing	Increasing	Increasing
Extreme rainfall events – droughts	Likely	Likely	Increasing	Increasing
Extreme rainfall events – storms and floods	Increasing	Increasing	Likely	Likely
Sea level rise	Increasing	Not available	Not available	Not available

Source: BNRCC and Federal Ministry of Environment (2011)

Scientific research seeks to generate knowledge. Commonly the lessons learnt are meant by researchers to contribute to public policies, and also of private interest to serve a wide diversity of goals. In all cases, there are stakeholders for whom scientific research can address the wide diversity of interests and perspectives by providing lesson learned. In addition, policy makers and managers in the public and private sectors recognize the need to be driven by knowledge. While this is the norm, in practice there is no consensus or unanimity of views of steps for the practical implementation of such research-driven policy development.

Nigeria has several policies related to climate change and environment. The process of developing these policies followed largely a top-down approach, where the federal government was mainly responsible for formulating the policies. Furthermore, climate change adaptation was not mainstreamed into these policies. This necessitated the need for a National Adaptation Strategy and Plan of Action on Climate Change for Nigeria, which used evidence from a bottom-up approach, to help address this situation.

The NASPA-CCN was a product of a Canadian International Development Agency (CIDA) supported Building Nigeria's Response to Climate Change (BNRCC) project implemented for four and half years in Nigeria. The BNRCC project included research, pilot projects, youth and communications activities and included a focus on gender in all project components. The research component included development of downscaling scenarios of future climate characteristics of Nigeria. Lessons learnt from all these components were used for climate change adaptation policy development which yielded the NASPA-CCN.

The BNRCC process of policy document development represents a classical and successful evidence-based approach. The objective of this chapter is to describe the steps followed in drawing lessons from these components of the BNRCC, steps adopted in synthesizing policy-relevant lessons from each component, and the perceptions about the process of developing the policy document. The NASPA-CCN was acknowledged prior to the COP18 in Doha by the UNFCCC as one model policy document that other countries could learn from (UNFCCC 2012).

---

## **Evidence-Based Policy**

To understand evidence-based policy, the chapter first described what policy, public policy, and public policy making are and the how they link with evidence-based policy.

## **Public Policy**

Policy is an effort to achieve desired outcomes by transforming the priorities and principles of governments into programs and courses of action. Thus, public policy can be viewed as a set of decisions by governments and other political actors to stimulate, modify, or frame a problem or issue that has significant impact



in the political domain by policy makers or the wider public (Hassel 2015; Howlett and Cashore 2014). More precisely, public policy is seen as government actions, the reasons they do it and the differences attributable to such actions (Dye 1976).

## **Policy Making**

As described above, policies are courses of actions which include goals and the resources to achieve them, regardless of how well or poorly formulated. Thus, policy making comprises both a technical and political process defining and matching the goals and means of different parties (Howlett and Cashore 2014). The public policy making process is concerned with provision of policy direction for the benefit of the public sector. This includes the identification, justification and formulation of relevant policies (Howlett and Cashore 2014).

## **Evidence-Based Policy Making**

The practice of informing policy using evidence has become progressively popular. This popularity is driven further by the activities of policy communities such as within government departments, research organizations, multilateral organization, think-tanks, and initiatives which advocate for evidence-based policy making. Evidence-based policy can be defined as an approach that helps an individual or organization to make well informed decisions about policies, programs and projects based on scientific and empirical evidence, including impact studies, cost-benefit analyses, program evaluation, and academic research (Leuz 2018; Sutcliffe and Court 2005). Additionally, evidence-based policy is a set of methods which does not aim to directly affect the policy outcomes; rather it influences the processes through which policies are developed. Evidence-based policy proposes a thorough and systematic approach and extends the traditional concepts of research to acquire a comprehensive understanding.

## **Why Evidence-Based Policy Is Important**

The importance of evidence-based policy is fairly apparent. The application of scientific knowledge and empirical evidence to policy decisions processes is sensible. The quest for Evidence-based policy is based on the premise that policy making should be informed by available evidence and should include rational analysis lead to better policies and regulations. Generally, policies based on evidence are considered to yield better results (Sutcliffe and Court 2005). Vital empirical evidences such as those generated from academic research can increase our understanding of the effects of policies. Furthermore, empirical evidences enforce discipline on policy making when they are theory-based which makes policy making less vulnerable to

political pressures and capture (Cairney 2016; Leuz 2018). Also, given that research benefits from public funding, it is expected to significantly contribute to advance knowledge for the society.

In a report for the Australian Department of Industry, Innovation, Science, Research and Tertiary Education, Palangkaraya et al. (2012) summarized the importance of evidence-based policy. According to Palangkaraya et al. (2012), evidence-based policy accounts for which entity is affected, the magnitude of these effects, and the net benefit for the society. They state, for example, that a sound economic policy ought to take into consideration both financial effects (such as productivity and income) and nonfinancial effects (such as environmental and social impacts). Secondly, evidence-based policy also analyzes the counterfactual of a proposed policy, for example, the impact of a specific policy on third party entities' welfare and behaviors as a result of the proposed policy. Thirdly, evidence-based policy empowers policy makers to study and improve already existing policies and programs. Fourthly, evidence-based policy empowers an analyst to measure if the impacts of policies or programs are biased toward one subgroup (such as demographic, economic, or region). Finally, evidence-based policy is valuable to the public sector owing to a lack of appropriate price signal. Due to the profit maximization motive, the private sector typically assesses the efficacy of projects using metrics such as stock prices and revenue. However, the public sector essentially creates its own metrics of impact and value with the aim to maximize societal welfare. Importantly, rigorous research and evidence from credible and independent parties can help gain the trust of key stakeholders and the public.

The literature on evidence-based policy making is typically grouped into two: (1) theoretical arguments in favor/critical of evidence-based approach and (2) theoretical proposal to improve the evidence-based policy making process (O'Dwyer 2004). These two groups assume that the availability of evidence is desirable in the decision-making process. However, interpretation of the soundness of evidence is often times unclear; while the interpretation is universally acceptable at a particular point in time in the natural sciences, interpretation is beset with disagreement in the social sciences. The literature highlights factors that influence policy making, which also serve as opportunity to improve the policy making process. Overall, evidence-based policy making is supported by the literature.

## **Difference Between Evidence-Based Policy and Nonevidence-Based Policy**

Evidence-based policy is closely related to non-evidence-based policy; however, there are major differences. There are basic assumptions of evidence-based policies in the literature: evidence-based policies is an important proposition, policy-makers should have access to evidence, properly interpreted evidence benefits policy development, evidence-based policies are superior to nonevidence-based policies (O'Dwyer 2004). Furthermore, there are different

actors or parties considered in the literature on policy making; these parties include the policy makers, researchers, and practitioners. Other parties with limited roles include evaluators, participants and affected third parties (Lemke and Harris-Wai 2015). There are often no direct links between these parties, however, policy making benefits most with a closer link between the policy makers and researchers. The application of evidence is the major difference between evidence-based-policy and nonevidence-based policy. Importantly, it is relevant evidence that matters, not just any evidence. Lack of an evidence base for policy making implies that policies will be based on other factors (such as values and ideology of both researchers and policy makers, current public opinion, and political goals) (O'Dwyer 2004). The success of evidence-based policy is based on the availability of an evidence base generated through rigorous research relevant to policy (Sutcliffe and Court 2006). Availability of an evidence base is a necessary but not sufficient condition for sound policy making. The availability of an administrator vested with the role of assembling and providing clarity on the quality of research and generated evidence.

## **Development of Evidence-Based Policy**

Different models have been used in the literature to explain the formulation and development of evidence-based policy. These models include, but are not limited to, knowledge drive model, problem-solving model, interactive model, political model, tactical model, and enlightenment model (for more details, see Almeida and Báscolo 2006; Daviter 2015; Trostle et al. 1999; Weiss 1979). These models can be applied jointly in analyzing the research-policy relation. It is also important to note that none of the models is sufficient to analyze the relationship, given the complexities inherent in the policy making process.

## **How Policy Makers Receive and Interpret the Outcomes of Specific Types of Research**

The need for various types of evidence in policy making processes has increased among governments around the world. The typical forms of evidence with implication for public policy, according to (O'Dwyer 2004), include:

1. Descriptive evidence (such as employment statistics and trade deficits)
2. Analytical evidence (deals with establishment of causal relationships and explanations)
3. Evaluative evidence (deals with the effectiveness of existing policies and programs)
4. Policy analysis (relevance is based on the analyst's position in relation to power)

## Sectoral Concentration of Evidence-Based Policy Making in Nigeria

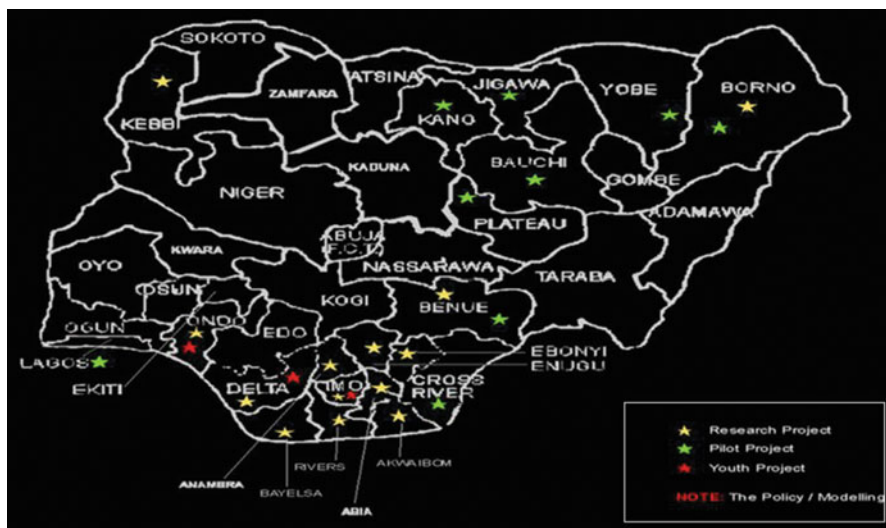
Evidence-based policy making in Nigeria is largely practiced in the health sectors (Onwujekwe et al. 2015; Uneke et al. 2017, 2018, Uzochukwu et al. 2016). This situation is also observed in most developed countries (Parkhurst et al. 2018). The reason for the predominant practice of evidence-based policy making in the health sector (physical science) compared with social science fields can be explained by analytical approaches used for evidence collection. The evidence-based approach was pioneered by the medical field, with techniques such as randomized controlled trials, which are straightforward and easy to comprehend. Analytical methods in the social science field are seen to be prone to errors and biases (Bhattacharjee 2012; Ioannidis et al. 2017). Evidence from the physical sciences is generally more acceptable to policy makers than evidence from the social science in the event of excess information and ambiguity (Ioannidis et al. 2017).

---

### The Frame: BNRCC

NASPA-CCN was a very practical example of evidence-based policy document. The methodology of the NASPA-CCN development specifies evidence driven process using scientific research and pilot project partners' inputs, with results mainstreamed into policy by first completing the Climate Change Adaptation Strategy Technical Report (CCA STR) and then using this information to develop the NASPA-CCN a key output of the BNRCC project.

The BNRCC project started 2007 had USD\$5M of funding from CIDA and was managed jointly by ICF-Marbek and CUSO-VSO, along with the Nigerian Environmental Study Action Team (NEST) as the Nigerian implementing partner. The project ran from 2007 to 2011. The project was developed on the basis of the achievements of an earlier initiative, the Canada-Nigeria Climate Change Capacity Development Project implemented with funding from CIDA'S Climate Change Capacity Development Funding (CCCDF, 2001–2004). The overall goal of the BNRCC project was to “*enhance Nigeria's ability to achieve equitable, sustainable poverty reduction through more effective governance related to climate change in Nigeria*” (Marbek Resource Consultants and CUSO 2007). The BNRCC project objectives included “*building Nigerian capacity to meet international commitments and adapt to climate change through improved governance promoting gender equality, poverty reduction and more sustainable natural resource management*” (Marbek Resource Consultants and CUSO 2007). The expected impact is improved capacity of Nigerians to respond to the effects of climate change, reducing the negative impacts on the livelihoods of vulnerable men and women (Marbek Resource Consultants and CUSO 2007). The BNRCC project had four components which included the research, pilot projects, outreach/networking/communication, and policy components. It was implemented in fifteen (15) states of Nigeria (Fig. 1). All project components, except the policy component, had Advisory Groups. The Advisory Groups provided guidance and contributed to decision-making related to



**Fig. 1** Map of Nigeria showing states where BNRCC Projects are located

their specific components. The Advisory Groups did not directly participate in implementation of project activities. Each Advisory Group was composed of 5 members, representing a range of expertise and perspectives. The groups had balanced membership with regard to gender, geography, and categories of stakeholder. Each Advisory Group met regularly (approximately 3–4 times per year) during the most active phase of the component for which the Group provided advice.

## Research Component

The research component had two categories of research carried out – socioeconomic research on climate change impacts, vulnerability, and adaptation; and climate scenario modeling. This component commissioned experts from diverse fields to carry out studies on socioeconomic aspects of climate change across Nigeria to generate evidence from the field. According to NEST (2011), the commissioned socioeconomic projects included:

1. Adaptation to Climate Change and Variability by Farming Households in the Niger Delta Region, Nigeria
2. Assessment of Impacts, Vulnerability, Adaptive Capacity and Adaptation to Climate Change in the Niger Delta Region, Nigeria
3. Gender Dimensions and Indigenous Knowledge for Adaptation to Climate Change in (a) Southeast Nigeria

The socioeconomic research projects collected gender disaggregated data and conducted gender analysis of the data collected. Gender was also considered in the

composition of the socioeconomic research projects teams. The consideration of gender in all activities of the socioeconomic projects was informed by the fact that climate change impacts are not gender neutral. Climate change affects everyone, but the way and manner it affects men, women, youths, the aged, and people with disability differ significantly. This will also inform the kind of adaptation strategies needed for different groups. Experts, who are academics from universities across Nigeria, with prerequisite knowledge of climate change were selected and commissioned after a nationwide call for expressions of interest.

Also, the Climate System Analysis Group (CSAG), Department of Environmental and Geographical Science, University of Cape Town, Rondebosch, South Africa was commissioned to generate climate scenario models and predict the future impacts of climate change in Nigeria. This subcomponent was important and a major accomplishment of the project because the findings generated provided information on how Nigeria's climate has changed over time and what is expected in the future. Global Circulation Models (GCMs) are too coarse to predict local scale impacts on agriculture, health, natural resources, etc., in different ecological zones of Nigeria. The BNRCC downscaling improves resolution with 1971–2000 climate data from 40 Nigerian Meteorological Agency (NIMET) stations to fill the gap (Babatunde et al. 2011).

This component generated new knowledge and tools of analysis of climate change scenarios, vulnerabilities and impacts on men and women in key sectors and eco-regional zones as well as their local adaptation practices to climate change. Furthermore, it developed regional climate predictions for Nigeria's eco-regional zones, developed vulnerability analyses for adaptation applications, and identified traditional and new response guidelines, practices, strategies, and technologies for climate change adaptation.

## **Pilot Projects Component**

The pilot projects reached 15 primary communities in 8 States from the coastal/rainforest, through the tall grass and short grass savannas to the Sahel ecological zones, covering Cross River, Benue, Plateau, Kano, Jigawa, Bauchi, Yobe, and Borno States. Knowledge generated from the pilot projects contributed greatly in developing the National Adaptation Strategy and Plan of Action on Climate Change for Nigeria (NASPA-CCN), a policy instrument now with the Federal Government. The Building Nigeria's Response to Climate Change project commissioned seven pilot projects partners across different ecological zones of the country to carry out community-based adaptation projects (NEST and Woodley 2011). According to NEST, Woodley (2011), the commissioned projects included:

1. Use of Agroforestry Strategies to Rehabilitate Sand Dunes and Improve Livelihoods of Rural Communities in the Nigerian Sahel
2. Strengthening Community-based Adaptation to Climate Change for Increased Food Security in Fragile Ecologies of Three Rural Communities in Bauchi and Jigawa States, Nigeria

3. Community-based Integrated Climate Change Adaptation Pilot Project in Two Communities of Plateau State
4. Promoting Climate Change Adaptation Best Practices in Communities in the Guinea and Sudan Savanna Regions of Nigeria
5. Alternative Livelihood Options as a Means to Promoting Community-based Adaptation to Climate Change in the Rainforest and Derived Savanna Zones of Nigeria
6. Alternative Livelihood Options as a Means to Promote Community-based Adaptation to Climate Change in two Coastal Communities in Akpabuyo Local Government Area of Cross River State
7. Alternative Livelihood Options as a Means to Promoting Community-based Adaptation to Climate Change in the Rainforest Zones of Nigeria

The pilot projects adopted a participatory, community-based adaptation, and demand-driven approach in its implementation (see NEST and Woodley 2012 for details). The pilot projects contributed in building resilience to climate change in Nigerian rural communities. Okali (2012) summarized how the pilot projects contributed to building resilience in rural communities. According to him, the pilot projects increased the buffer capacity of rural farming communities through promoting several livelihood diversification activities, training community members in project management, mainstreaming gender in all project activities, value addition of farm produce, introducing and promoting improved cookstoves, and promoting sustainable land management practices. The pilot projects also strengthened the capacity of rural communities for self-organization and enhanced their adaptive capacities (Okali 2012). In strengthening rural communities' capacity for self-organization, the projects adopted participatory approach in choosing and implementing adaptation interventions in the communities, formed project implementation committees (PIC) in the communities, formed and strengthened community-based organizations, included youths, men and women in projects' management and decision making, ensured that communities take full ownership of the projects to promote sustainability, and relied on local resources in project implementation and management (NEST and Woodley 2012). The project built adaptive capacities of rural communities through learning, creating awareness, knowledge and experience sharing, training, provision of peer education tools for knowledge transfer, creating a platform for different stakeholders to interact freely and provide feedback, and encouraging scaling up successful interventions beyond initial communities (NEST and Woodley 2012). For example, the water project in Kwaikong community in Plateau State (initial project community) was replicated in Kayarda community, and the Local Government Chairman of Langtang South donated about ₦500,000 to support the promotion of adaptation activities in his area (NEST and Woodley 2011). Some of the notable outcomes of the project included neighboring communities of all pilot project communities requesting early maturing varieties of crops tested and cultivated in initial project communities; and more farmers in some communities in the savanna area requesting more shallow wells for irrigation farming as a result of the success recorded in dry seasons after testing the shallow wells in the communities.

## The NASPA-CCN

The main thrust of the NASPA-CCN is to “*minimize risks, improve local and national adaptive capacity and resilience, leverage new opportunities, and facilitate collaboration with the global community, all with a view to reducing Nigeria’s vulnerability to the negative impacts of climate change*” (BNRCC and Federal Ministry of Environment 2011). This Plan of Action identified 13 priority sectors impacted by climate change in Nigeria. These sectors include agriculture (crops and livestock), freshwater resources, coastal water resources and fisheries, forests, biodiversity, health and sanitation, human settlements and housing, energy, transportation and communications, industry and commerce, disaster, migration and security, livelihoods, vulnerable groups, and education. The impacts of climate change on these sectors and the recommended adaptation strategies were drawn mainly from results of the pilot and research projects of the BNRCC.

Recognizing the role different stakeholders play in climate change adaptation (AECOM 2013), the NASPA-CCN allocates concrete responsibilities to all stakeholders including the federal government, state governments, local governments, civil society organizations, international development partners, communities and organized private sector with the government, the private sector, and civil society providing strong and visionary leadership. The federal government is expected to provide the overarching policy and legislative leadership, the states and the local governments lead in the regions and at the grassroots, the organized private sector explores business opportunities presented by climate change, while civil society organizations continue to act as catalysts at the adaptation frontline (BNRCC and Federal Ministry of Environment 2011). The process of developing the NASPA-CCN is described in details in the section that follows.

---

## Process of Developing the NASPA-CCN

The NASPA-CCN led by four main partners including Building Nigeria’s Response to Climate Change project of the Nigerian Environmental Study Action Team Ibadan, Heinrich Boll Foundation, NigeriaCAN (Nigeria Climate Action Network), and the Special Climate Change Unit (now the Department of Climate Change) of the Federal Ministry of Environment, was developed through an innovative process (see BNRCC and Federal Ministry of Environment 2011 for details). The development of the document involved all relevant stakeholders and experts in climate change space including communities, civil society groups, researchers, and specialists of different sectors. The Lead partners engaged with prominent stakeholders to set-up a multistakeholder process to develop the strategy document. A 25-member Multi-Stakeholder Forum whose membership was drawn from the government (local, state, and federal government officials), nongovernmental organizations, private sector operators, and researchers was formed to provide oversight (BNRCC and Federal Ministry of Environment 2011). The document largely used findings from the Building Nigeria’s Response to Climate Change research and community-based adaptation projects.



The BNRCC project staff worked to develop a draft national strategy, drawing heavily on the knowledge gained through BNRCC's pilot projects and research. BNRCC engaged policy/research consultants to collect background research on existing climate change policy and advise on the development of sectoral adaptation strategies. BNRCC first commissioned experts of different sectors (agriculture, freshwater resources, coastal water resources and fisheries, forests, biodiversity, health and sanitation, human settlements and housing, energy, transportation and communications, industry and commerce, disaster, migration and security, livelihoods, vulnerable groups, and education) to produce the Climate Change Adaptation Strategy Technical Report (CCASTR) using inputs/finding from BNRCC's research and pilot projects and other relevant studies. The BNRCC team designed the table of contents of the report and presented and circulated it to the individual writers during different meetings and workshops. The team also designed three templates/tables for analyzing and synthesizing inputs from BNRCC's research and pilot projects and other relevant studies. These tables included Hazard-Impact-Vulnerability-Adaptation Matrix for all sectors in all ecozones in Nigeria; Policies, Programs, Adaptation Options Addressed, Implementing Agency and Cost Table; and Evaluation of Proposed Policies Table (see NEST and Tegler 2011 for details). These tables were populated by the commissioned writers/specialist of different sectors using findings that emerged from BNRCC's research and pilot projects and other relevant studies. The output of this process was a technical report called, Climate Change Adaptation Strategy Technical Report. The BNRCC team distilled the CCASTR text, produced the first draft of NASPA-CCN, and widely circulated the draft to stakeholders and experts for inputs (BNRCC and Federal Ministry of Environment 2011). Inputs received from stakeholders and experts were duly considered and incorporated in the document. The main focus of NASPA-CCN was priority policies, programs, plans, and actions.

---

## Methodology

We conducted a survey across the country to determine stakeholders' perceptions about the NASPA-CCN and the process of producing it. The survey was carried out between October 2018 and May 2019. One hundred and twenty respondents drawn from federal ministries, departments, and agencies; state ministries, local governments; civil society organizations; academia (lecturers and postgraduate students); media; private sector operators; and communities participated in the survey. We presented the results of the survey in the result section.

---

## Result

### How Would You Rate the Process of Developing NASPA-CCN?

The rating of the process of developing NASPA-CCN is presented in Table 2. Majority (52.50%) of the respondents believed that the process was a very good one. The process followed a systematic manner in developing the document.

Multistakeholders forum composed of experts in their various organizations were established. A group of authors were also commissioned to write the Climate Change Adaptation Strategy Technical Report (CCASTR) using largely evidence from BNRCC's pilot and research projects. After writing the CCASTR, the BNRCC team distilled the NASPA-CCN from the CCASTR and several workshops and meetings were held to validate the document. This rating implies that the process of producing the NASPA-CCN is a largely accepted way of policymaking in Nigeria and countries with similar contexts.

### What Do You Consider as the Key Success Factors of the NASPA-CCN Process?

Four key factors were identified and considered by stakeholders as the main contributors to the success of the NASPA-CCN as reported in Table 2. These include gender consideration in all activities that led to developing of NASPA-CCN, using evidence-based approach in developing the document – using concrete evidence from research and pilot projects, engaging/consulting relevant stakeholders in the process, and ensuring that all priority sectors affected by climate change were identified and considered in the process of developing the document. The evidence-based approach (reported by 90.00% of the respondents) applied in developing the document appeared to be most considered success factor (Table 3).

**Table 2** Rating of the process of developing NASPA-CCN

Rating	Frequency	Percentage
Excellent	27	22.50
Very Good	63	52.50
Good	21	17.50
Fair	6	5.00
Bad	3	2.50
<b>Total</b>	<b>120</b>	<b>100.00</b>

**Table 3** Key success factors of the NASPA-CCN process

Rating	Frequency	Percentage
Gender consideration	96	80.00
Using evidence from research and pilot projects in developing the document	108	90.00
Engaging/consulting relevant stakeholders in the process	105	87.50
Identification and consideration of all priority sectors affected by climate change	99	82.50

## Limitations

This study was based on the knowledge and experience of the first three authors, who were part of the BNRCC team, CCASTR, and NASPA-CCN processes. Also, these authors were involved in preparing the first draft of NASPA-CCN. The chapter benefitted largely from the authors' knowledge and experience generated during implementation of the BNRCC project, CCASTR, and NASPA-CCN processes. The chapter rated stakeholders' perception about the process of producing the NASPA-CCN. Although many of the respondents interviewed were not involved in the NASPA-CCN process, they have read the NASPA-CCN and some other BNRCC reports, which informed their responses. However, our chapter did not focus broadly on the subject of climate change but the practical experiences and lessons learnt from the development of the NASPA-CCN which policy developers not just on climate change, but broader subject could learn in order to mainstream research lessons into policy.

---

## Conclusion

The concept of evidence-based policy making does not necessarily imply good policy making. Biased evidence could lead to bad policy making decisions with damaging outcomes. Similarly, policies can be considered bad if their outcomes are ineffective, even if they utilize evidence-based. Evidence-based policy focuses mainly on the policy making process, however, good policy making not only considers the processes, but the policy outcomes (O'Dwyer 2004). Hence, it is recommended that evidence-based policy making should consider both processes and outcomes in order to be effective.

This chapter documented the experience and knowledge gained about the process of evidence-based policy making as well as adaptation to climate change impacts at the community level, acquired from implementing the BNRCC. The chapter also rated stakeholders' perception about the process of developing the NASPA-CCN – an evidence-based policy document driven by the BNRCC project. The process of developing the strategy document was generally rated to be very good. The project used concrete evidence from research and pilot projects, engaged/consulted all relevant stakeholders in the process, ensured that all priority sectors affected by climate change were identified and considered in the process of developing the document, and mainstreamed gender in the project and process. These factors played a significant role in the success of the BNRCC project and developing and delivering the NASPA-CCN. In particular, the BNRCC pilot projects contributed to building resilience of communities and sectors across the different ecological zones of Nigeria by improving the buffer capacity and capacities for self-organization and adaptive management.

## References

- AECOM (2013) Supporting evidence-based adaptation decision-making in Western Australia: a synthesis of climate change adaptation research. National Climate Change Adaptation Research Facility, Gold Coast
- Almeida C, Báscolo E (2006) Use of research results in policy decision-making, formulation, and implementation: a review of the literature. *Cad Saude Publica* 22:S7–S19
- Babatunde JA, Salami AT, Tadross M (2011) Climate change scenarios for Nigeria: understanding biophysical impacts. Building Nigeria's Response to Climate Change Project Report. Nigerian Environmental Study/Action Team (NEST), Ibadan
- Bhattacharjee A (2012) Social science research: principles, methods, and practices, 2nd edn. Retrieved from [http://scholarcommons.usf.edu/oa\\_textbooks/3](http://scholarcommons.usf.edu/oa_textbooks/3)
- Building Nigeria's Response to Climate Change (BNRCC), Federal Ministry of Environment (2011) National Adaptation Strategy and Plan of Action on Climate Change for Nigeria (NASPA-CCN). Federal Ministry of Environment, Abuja
- Cairney P (2016) The role of evidence in theories of the policy process. In: The politics of evidence-based policy making. Palgrave Pivot, London
- Daviter F (2015) The political use of knowledge in the policy process. *Policy Sci* 48(4):491–505. <https://doi.org/10.1007/s11077-015-9232-y>
- Dye TR (1976) Policy analysis: what governments do, why they do it, and what difference it makes. University of Alabama Press, Alabama
- Gagliarducci S, Paserman, MD, Patacchini E (2019) Hurricanes, climate change policies and electoral accountability. IZA Institute of Labor Economics Discussion Paper Series, IZA DP No. 12334, Bonn
- Hassel A (2015) Public policy. *International Encyclopedia of the Social & Behavioral Sciences* (Second E. Wright, Ed.). pp 569–575. <https://doi.org/10.1016/B978-0-08-097086-8.75029-X>
- Head BW (2008) Research and evaluation: three lenses of evidence-based policy. *Aust J Public Adm* 67(1):1–11
- Howlett M, Cashore B (2014) Conceptualizing public policy BT – comparative policy studies: conceptual and methodological challenges (eds: Engeli I, Allison CR). [https://doi.org/10.1057/9781137314154\\_2](https://doi.org/10.1057/9781137314154_2)
- Ioannidis JPA, Stanley TD, Doucouliagos H (2017) The power of bias in economics research. *Econ J* 127(605):F236–F265. <https://doi.org/10.1111/ecoj.12461>
- Intergovernmental Panel on Climate Change (IPCC) (2013) Climate change 2013: the physical science basis. Contribution of working group I to the fifth assessment report of the intergovernmental panel on climate change (eds: Stocker TF, Qin D, Plattner G-K, Tignor M, Allen SK, Boschung J, Nauels A, Xia Y, Bex V, Midgley PM). Cambridge University Press, Cambridge, UK/New York
- Intergovernmental Panel on Climate Change (IPCC) (2014a) Climate change 2014: synthesis report. Contribution of working groups I, II and III to the fifth assessment report of the intergovernmental panel on climate change (eds: Pachauri RK, Meyer LA). IPCC, Geneva
- Intergovernmental Panel on Climate Change (IPCC) (2014b) Climate change 2014: impacts, adaptation, and vulnerability. Contribution of working group II to the fifth assessment report of the intergovernmental panel on climate change (eds: Field CB, Barros VR, Dokken DJ, Mach KJ, Mastrandrea MD, Bilir TE, Chatterjee M, Ebi KL, Estrada YO, Genova RC, Girma B, Kissel ES, Levy AN, MacCracken S, Mastrandrea PR, White LL). Cambridge University Press, Cambridge, UK/New York
- Intergovernmental Panel on Climate Change (IPCC) (2014c) Climate change 2014: mitigation of climate change. Contribution of working group III to the fifth assessment report of the intergovernmental panel on climate change (eds: Edenhofer O, Pichs-Madruga R, Sokona Y, Farahani E, Kadner S, Seyboth K, Adler A, Baum I, Brunner S, Eickemeier P, Kriemann B, Savolainen J, Schlömer S, von Stechow C, Zwickel T, Minx JC). Cambridge University Press, Cambridge, UK/New York

- Lemke AA, Harris-Wai JN (2015) Stakeholder engagement in policy development: challenges and opportunities for human genomics. *Genet Med* 17(12):949–957. <https://doi.org/10.1038/gim.2015.8>
- Leuz C (2018) Evidence-based policymaking: promise, challenges and opportunities for accounting and financial markets research. *Account Bus Res* 48(5):582–608. <https://doi.org/10.1080/00014788.2018.1470151>
- Marbek Resource Consultants, CUSO (2007) Project implementation plan of building Nigeria's response to climate change submitted to the Canadian International Development Agency by Marbek Resource Consultants/CUSO, Ottawa
- Nigerian Environmental Study Action Team (NEST) (2011) Reports of research projects on impacts and adaptation – climate change in Nigeria. A Compendium of Reports commissioned by Building Nigeria's Response to Climate Change (BNRCC), Nigerian Environmental Study/Action Team (NEST), Ibadan
- Nigerian Environmental Study Action Team (NEST), Tegler B (2011) Climate change adaptation strategy technical reports – Nigeria, (CCASTR). A Compendium of Studies commissioned by Building Nigeria's Response to Climate Change, Nigerian Environmental Study/Action Team (NEST), Ibadan
- Nigerian Environmental Study Action Team (NEST), Woodley E (2011) Reports of pilot projects in community-based adaptation – climate change in Nigeria. A Compendium of Reports commissioned by Building Nigeria's Response to Climate Change (BNRCC), Nigerian Environmental Study/Action Team (NEST), Ibadan
- Nigerian Environmental Study Action Team (NEST), Woodley E (2012) Learning from experience – community-based adaptation to climate change in Nigeria, Building Nigeria's Response to Climate Change, Nigerian Environmental Study/Action Team (NEST), Ibadan
- Niang I, Ruppel OC, Abdrabo MA, Essel A, Lennard C, Padgham J, Urquhart P (2014) Africa. In: Barros VR, Field CB, Dokken DJ, Mastrandrea MD, Mach KJ, Bilir TE, Chatterjee M, Ebi KL, Estrada YO, Genova RC, Girma B, Kissel ES, Levy AN, MacCracken S, Mastrandrea PR, White LL (eds) *Climate change 2014: impacts, adaptation, and vulnerability. Part B: Regional aspects. Contribution of working Group II to the fifth assessment report of the intergovernmental panel on climate change.* Cambridge University Press, Cambridge, UK/New York
- Nutley S, Walter I, Davies HTO (2009) Promoting evidence-based practice: models and mechanisms from cross-sector review. *Res Soc Work Pract* 19(5):552–559
- O'Dwyer L (2004) A critical review of evidence-based policy making. Australian Housing and Urban Research Institute (AHURI) Final Report No. 58
- Okali D (2012) Building resilience: the future road map. Third Ibadan Sustainable Development Summit (ISDS) on Building Resilience in Sustainable Development in a Changing World. University of Ibadan, Ibadan, 6–10 August, 2012
- Onwujekwe O, Uguru N, Russo G, Etiaba E, Mbachu C, Mirzoev T, Uzochukwu B (2015) Role and use of evidence in policymaking: an analysis of case studies from the health sector in Nigeria. *Health Res Policy Syst* 13(1):46. <https://doi.org/10.1186/s12961-015-0049-0>
- Onyeneke RU, Mmagu CJ, Aligbe JO (2017) Crop farmers' understanding of climate change and adaptation practices in Southeast Nigeria. *World Rev Sci Technol Sustain Dev* 13(4):299–318
- Palangkaraya A, Elizabeth W, Cherastiditham T (2012) Evidence-based policy: data needed for robust evaluation of industry policies. A Report for the Australian Department of Industry, Innovation, Science, Research and Tertiary Education. Institute of Applied Economic and Social Research, University of Melbourne, Melbourne
- Parkhurst J, Stefanie E, Hawkins B (2018) Evidence use in health policy making: an international public policy perspective. Palgrave Macmillan, Cham
- Pawson R (2002a) Evidence-based policy: in search of a method. *Evaluation* 8(2):157–181
- Pawson R (2002b) Evidence-based policy: the promise of realist synthesis. *Evaluation* 8(3):340–358
- Sutcliffe S, Court J (2005) Evidence-based policymaking: what is it? How does it work? What relevance for developing countries? Overseas Development Institute. <https://www.odi.org/sites/odi.org.uk/files/odi-assets/publications-opinion-files/3683.pdf>

- Sutcliffe S, Court J (2006) Toolkit for progressive policymakers in developing countries. Overseas Development Institute (ODI), London
- Tarfa PY, Ayuba HK, Onyeneke RU, Idris N, Nwajiuba CA, Igberi CO (2019) Climate change perception and adaptation in Nigeria's Guinea Savanna: Empirical evidence from farmers in Nasarawa State, Nigeria. *Appl Ecol Environ Res* 17(3):7085–7112
- Trostle J, Bronfman M, Langer A (1999) How do researchers influence decision-makers? Case studies of Mexican policies. *Health Policy Plan* 14(2):103–114. <https://doi.org/10.1093/heapol/14.2.103>
- Uneke CJ, Sombie I, Keita N, Lokossou V, Johnson E, Ongolo-Zogo P, Uro-Chukwu HC (2017) Promoting evidence informed policy making in Nigeria: a review of the maternal, newborn and child health policy development process. *Health Promot Perspect* 7(4):181–189. <https://doi.org/10.15171/hpp.2017.33>
- Uneke CJ, Ezeoha AE, Uro-Chukwu HC, Ezeonu CT, Igboji J (2018) Promoting researchers and policy-makers collaboration in evidence-informed policy-making in Nigeria: outcome of a two-way secondment model between university and health ministry. *Int J Health Policy Manag* 7(6):522–531
- UNFCCC (2012) Compilation of case studies on national adaptation planning processes. <https://unfccc.int/sites/default/files/resource/docs/2012/sbsta/eng/inf06.pdf>
- Uzochukwu B, Onwujekwe O, Mbachu C, Okwuosa C, Etiaba E, Nyström ME, Gilson L (2016) The challenge of bridging the gap between researchers and policy makers: experiences of a Health Policy Research Group in engaging policy makers to support evidence informed policy making in Nigeria. *Glob Health* 12(67). <https://doi.org/10.1186/s12992-016-0209-1>
- Weiss C (1979) The many meanings of research utilization. *Public Adm Rev* 39:429–431
- World Bank (2019) The World Bank Group Action plan on climate change adaptation and resilience: managing risks for a more resilient future. World Bank, Washington, DC

**Open Access** This chapter is licensed under the terms of the Creative Commons Attribution 4.0 International License (<http://creativecommons.org/licenses/by/4.0/>), which permits use, sharing, adaptation, distribution and reproduction in any medium or format, as long as you give appropriate credit to the original author(s) and the source, provide a link to the Creative Commons license and indicate if changes were made.

The images or other third party material in this chapter are included in the chapter's Creative Commons license, unless indicated otherwise in a credit line to the material. If material is not included in the chapter's Creative Commons license and your intended use is not permitted by statutory regulation or exceeds the permitted use, you will need to obtain permission directly from the copyright holder.





# Using Inclusive Finance to Significantly Scale Climate Change Adaptation

# 125

Robert Wild, Moses Egaru, Mark Ellis-Jones,  
Barbara Nakangu Bugembe, Ahmed Mohamed, Obadiah Ngigi,  
Gertrude Ogwok, Jules Roberts, and Sophie Kutegeka

## Contents

Introduction .....	2567
The Need for Green Community-Level Inclusive Finance to Meet the SDGs .....	2567
Ecosystem Restoration and Management as a Route to Climate Adaptation and Mitigation .....	2567
Increasing Availability of the Financial Resources for Ecosystem Restoration and Management .....	2569
Urgency to Engage the Unbanked Rural Majority in Face of the Climate Emergency .....	2569
The Need for Green Inclusive Finance to Incentivize Adaptation Actions of Rural Producers .....	2569
Defining Inclusive Eco-credit .....	2570

This chapter was previously published non-open access with exclusive rights reserved by the Publisher. It has been changed retrospectively to open access under a CC BY 4.0 license and the copyright holder is “The Author(s)”. For further details, please see the license information at the end of the chapter.

R. Wild (✉) · M. Ellis-Jones · O. Ngigi · J. Roberts  
GreenFi Systems Ltd, Dublin, Ireland  
e-mail: [rob@greenfi.org](mailto:rob@greenfi.org); [mark@greenfi.org](mailto:mark@greenfi.org); [obadiah@greenfi.org](mailto:obadiah@greenfi.org); [jules@greenfi.org](mailto:jules@greenfi.org)

M. Egaru · B. N. Bugembe · G. Ogwok · S. Kutegeka  
International Union for Conservation of Nature – IUCN, Gland, Switzerland  
e-mail: [Moses.egaru@iucn.org](mailto:Moses.egaru@iucn.org); [barbara.nakangu@iucn.org](mailto:barbara.nakangu@iucn.org); [Gertrude.ogwok@iucn.org](mailto:Gertrude.ogwok@iucn.org); [ophie.kutegeka@iucn.org](mailto:ophie.kutegeka@iucn.org)

A. Mohamed  
Garissa University, Garissa, Kenya  
e-mail: [maalimahmed@gmail.com](mailto:maalimahmed@gmail.com)

Community Environment Conservation Fund .....	2573
Background to the Model .....	2573
Implementing the IUCN Resilience Framework – RESFRAM .....	2573
CECF Principles .....	2574
CECF Results .....	2575
External Funding for CECF Groups .....	2577
Verifiable Financial, Environmental, and Social Performance .....	2577
CECF Conclusions .....	2578
Other Community-Level Financial Infrastructure for Climate Change Adaptation .....	2579
The Climate Smart Lending Platform .....	2579
Village Savings and Loans Associations .....	2580
Sustainable Value Chains .....	2582
Social Safety Net Funding and Internal Employment .....	2582
Scaling Up Community Eco-credit .....	2583
Technology: Mobile Phone and Web-Based Applications .....	2583
Establishing Large-Scale Funding .....	2583
Discussion .....	2584
Scale Relevance of Community Eco-credit .....	2584
Advantage of Community Eco-credit .....	2585
Aggregation for Ecosystem Management .....	2586
Conclusion and Recommendations .....	2586
References .....	2587

## Abstract

Reversing land degradation and achieving ecosystem restoration and management are routes to climate change adaptation and mitigation. The financial resources to achieve this are increasingly available. A major challenge is the absence of scalable mechanisms that can incentivize rapid change for rural communities at the decade-long time scale needed to respond to the climate emergency. Despite moves toward inclusive green finance (IGF), a major structural gap remains between the funding available and the unbankable small-scale producers who are stewards of ecosystems. This chapter reports on inclusive finance that can help fill this gap and incentivizes improved ecosystem stewardship, productivity, and wealth creation. A key feature is the concept of eco-credit to build ecosystem management and restorative behaviors into loan terms. Eco-credit provides an approach for overcoming income inequality within communities to enhance the community-level ecosystem governance and stewardship. The paper discusses the experience of implementing the Community Environment Conservation Fund (CECF) over a 8-year-period from 2012. The CECF addresses the unbankable 80% of community members who cannot access commercial loans, has c. 20,000 users in Uganda and pilots in Malawi, Kenya, and Tanzania. The model is contextualized alongside complementary mechanisms that can also incentivize improved ecosystem governance as well as engage and align communities, government, development partners, and the private sector. This complementary infrastructure includes commercial eco-credit as exemplified by the Climate Smart Lending Platform, and the community finance of the Village Savings and Loans Associations (VSLA) model upon which CECF builds. The paper describes the technologies and climate finance necessary for significant scale-up.



---

**Keywords**

Climate change adaptation · Mitigation · East Africa · Ecosystems governance · Inclusive finance · Nature-based solutions · Technology · Land degradation neutrality · Forest landscape restoration · Incentive mechanism

---

**Introduction**

The objectives of this chapter are to (a) provide a background to the need for community-level inclusive finance to incentivize change adaptation and mitigation, (b) outline the concept of eco-credit, (c) describe an operational model of community eco-credit that shows promise to incentivize ecosystem management, climate change adaptation, and mitigation as well as disaster resilience building at the community level, and (d) place this model in a framework of complementary allied approaches. The paper also discusses the potential for scale-up and makes recommendations for future work. The paper is written by the innovators, designers, and implementers of the model over its 8-year development period (staff of the International Union for Conservation of Nature) and a group that have independently reviewed the approach (Ellis-Jones et al. 2018), and who are also designing the web-based and mobile-phone technology tools and models to support its scale-up (GreenFi Systems Ltd, a social enterprise). The paper's focus is ecosystem or landscape conservation, management, and restoration, but the model can include other environmentally positive actions.

The approach has been subject to a number of reviews including Kakuru and Masiga (2016), Ellis-Jones et al. (2018), World Bank (2017), Mott MacDonald (2018a, b), Roberts (2017), and Wild (2019). A limitation of the program was that the reviews indicated weaknesses in monitoring component with the absence of an impact monitoring protocol in the IUCN CECF Guidelines (IUCN 2013), particularly for assessing verified environmental and social impact. This monitoring protocol needs addressing in the main pilot location and warrants further research and development.

---

**The Need for Green Community-Level Inclusive Finance to Meet the SDGs****Ecosystem Restoration and Management as a Route to Climate Adaptation and Mitigation**

Land and ecosystem degradation is now considered to affect almost 25% of the world's land area causing a loss in ecosystem goods and services, costing an estimated US\$6.3 trillion a year (WRI 2017), and is increasingly gaining attention in the development agenda. Similar analyses have been carried out for coastal ecosystems (Pendleton et al. 2012; Nichols et al. 2019). Approaches to addressing land and coastal degradation include land-degradation neutrality, forest landscape restoration, and ecosystem restoration as championed under the UNCCD, UNFCCC, and the

Convention on Biological Diversity (Aichi target 15). These approaches are also embedded in the UN sustainable development goals (SDG), particularly under SDG 13, 14, and 15. Additionally, reversing land degradation and restoring ecosystems are seen as attractive nature-based solutions to climate change adaptation and mitigation. A recent study identifies and quantifies 20 conservation, restoration, and improved land management actions that increase carbon storage and/or avoid greenhouse gas emissions across global forests, wetlands, grasslands, and agricultural lands. They estimate that these 20 “natural climate solutions” (NCS) can provide 37% of cost-effective CO<sub>2</sub> mitigation needed through 2030 for a >66% chance of holding warming to below 2 °C. They suggest their analysis provides a robust basis for immediate global action to improve ecosystem stewardship as a major solution to climate change (N.B. the authors define a <2 °C “cost-effective” level of mitigation as a marginal abatement cost not greater than ~100 USD MgCO<sub>2</sub><sup>-1</sup> as of 2030) (Griscom et al. 2017).

This study is underscored by the recent IPCC report on land and climate change (IPCC 2019, 1543 pp.), which sets out in considerable depth of the linkages between people, land, and climate. It identifies the adaptation and mitigation response options, how these can be enabled and the required near-term actions. Specifically, it identifies that many land-related responses that contribute to climate change adaptation and mitigation can also combat land degradation and enhance food security. One of the key actions is sustainable land management which by reducing and reversing land degradation, at scales from individual farms to entire watersheds, can provide cost effective, immediate, and long-term benefits to communities with co-benefits for adaptation and mitigation. Enabling response options included in the report include; *“The appropriate design of policies, institutions and governance systems at all scales. These can be enabled by improving access to markets, securing land tenure, factoring environmental costs into food, **making payments for ecosystem services, and enhancing local and community collective action. The effectiveness of decision-making and governance is enhanced by the involvement of vulnerable local stakeholders. ... Near term actions are to build individual and institutional capacity, accelerate knowledge transfer, enhance technology transfer and deployment, enable financial mechanisms, implement early warning systems, undertake risk management and address gaps in implementation and upscaling**”* (extracted from IPCC 2019 our emphasis). According to the report these near-term actions can also bring social, ecological, economic, and development co-benefits that can contribute to poverty eradication and more resilient livelihoods for those who are vulnerable (IPCC 2019). The community eco-credit approach described here is designed to address many of these issues at the local level with a high level of community self-determination and engagement. Better ecosystem stewardship, which essentially (but not exclusively) means governance (including tenure and rights), will also support community stewards to adapt to climate change, through building resilience within interlinked social-ecological and socio-economic institutions at the community level. Resilience here means conserved and where necessary restored, well managed, and productive ecosystems, strong, fairly governed institutions, and integrated robust financial systems.

## **Increasing Availability of the Financial Resources for Ecosystem Restoration and Management**

In addition to this, the financial resources to achieve ecosystem and land conservation and restoration at scale are now becoming available. Since 2006, when land degradation became a focal area, the Global Environment Facility has invested more than US\$1 billion in sustainable land management practices (GEF 2019). Newer mechanisms such as the US\$300 million Impact Investment Fund for Land Degradation Neutrality (UNCCD 2019) and the Green Climate Fund, which has received US\$7.2 billion and which includes ecosystem restoration in its portfolio (World Bank 2019), are also supporting these efforts. However, efficiency, effectiveness, and very importantly equity remain critical questions, which must be addressed if public support is to be retained for this type of expenditure of public funds.

## **Urgency to Engage the Unbanked Rural Majority in Face of the Climate Emergency**

Climate change is happening more rapidly than predicted (IPCC 2019), with deeper and more serious climate-related disasters of increasing frequency and severity. This engenders a greater sense of urgency with the need to help communities and broader society to adapt to climate change and restore the capacity of ecosystems to absorb carbon. While restoring land sounds an appealing solution, the reality is that many communities remain locked into a resource-poor existence unable to make the necessary investments in labor, time, and land to restore their ecosystems upon which they depend. It is also important to remember that vulnerability to climate impacts disproportionately affect marginalized members of many communities including women, youth, and elderly who are exposed to greater risks (Deering 2019).

## **The Need for Green Inclusive Finance to Incentivize Adaptation Actions of Rural Producers**

In this chapter, we refer broadly to small-scale rural producers meaning female and male farmers (including pastoralists), fishers, and foresters that manage customarily or privately owned as well as the common pool land and sea resources. We prefer this term over smallholders or small-scale farmers as these terms imply livelihood options and tenure assumptions that may not hold true. In the literature, however, these latter terms are frequently used (e.g., Dalberg 2012, 2016; Verdone 2018) and are therefore used here somewhat interchangeably.

Dalberg (2012), in their analysis of the financial needs of unbanked small-scale farmers, recognized that “*These smallholders also represent stewards of natural*

resources that are in need of sustainable management to prevent deforestation and degradation of ecosystems” and further noted that “Smallholder farming methods often turn to survival tactics that degrade the ecosystems farmers depend on. Constrained by low productivity and an inability to invest in their property, smallholders sometimes resort to shorter-term measures such as illegal logging, slash-and-burn agriculture, and intensive monoculture that impairs the viability of the ecosystems they depend on.” Dalberg (2016) identifies this group to be 450–500 households million representing 2 billion people. Similarly, Verdone (2018) focusing on forest resources estimates that worldwide 1.5 billion smallholders depend on forest landscapes to produce food, meet their subsistence needs, and generate income. If small-scale fishers are added, this number is likely to increase. Dalberg 2016, considers that 80% are unbanked as they present too high credit risk for private sector investment (through credit or value chains). This represents a significant and largely unrecognized barrier to apply natural solutions to climate change especially via private sector investment (including impact funds). It is further noted that access to credit has been recognized, along with extension and information, to be the main drivers behind adaptation to climate change at the farm household level (Di Falco et al. 2011).

Given, therefore, that rural communities are severely cash constrained and that conservation often imposes opportunity costs, finding appropriate inclusive financial incentive mechanisms, including credit, for climate change adaptation and mitigation is critical. Approaches developed thus far include payments for ecosystem services (PES) and reducing emissions through deforestation and forest degradation (REDD). While huge investments have been made especially in REDD (and REDD +), progress has been slow (Clements 2010; Brockhaus et al. 2015; Börner et al. 2017; Ferraro 2017; Milbank et al. 2018; Andrews et al. 2020). An approach that has not been well explored is using inclusive finance and community savings and loan models to incentivize ecosystem management or restoration activities. We suggest this approach needs great attention and could also support the scale-up of both PES and REDD+.

---

## Defining Inclusive Eco-credit

This chapter now sets out to define eco-credit and outlines an idealized theory of change which it incentivizes (Table 1). Eco-credit is here defined as “*credit that is conditional on ecological actions undertaken by the borrower as required under loan terms.*” The term was coined by the start-up company F<sub>3</sub>Life (<https://f3-life.com>), the winner of the UN prize for climate change finance innovation in 2014 (UNDP 2014). Inclusive eco-credit can be further divided into two types – community and commercial and defined here. “Community eco-credit,” which is the subject of this chapter, is defined as “*credit, managed at the community level, conditional on ecological actions undertaken by the community member borrower required under the loan terms.*” “Commercial eco-credit” is defined as “*credit issued by a commercial lender, conditional on ecological actions undertaken by the borrower required under loan terms.*” Eco-credit can be considered nested within

**Table 1** Idealized theory of change for eco-credit groups and climate adaptation

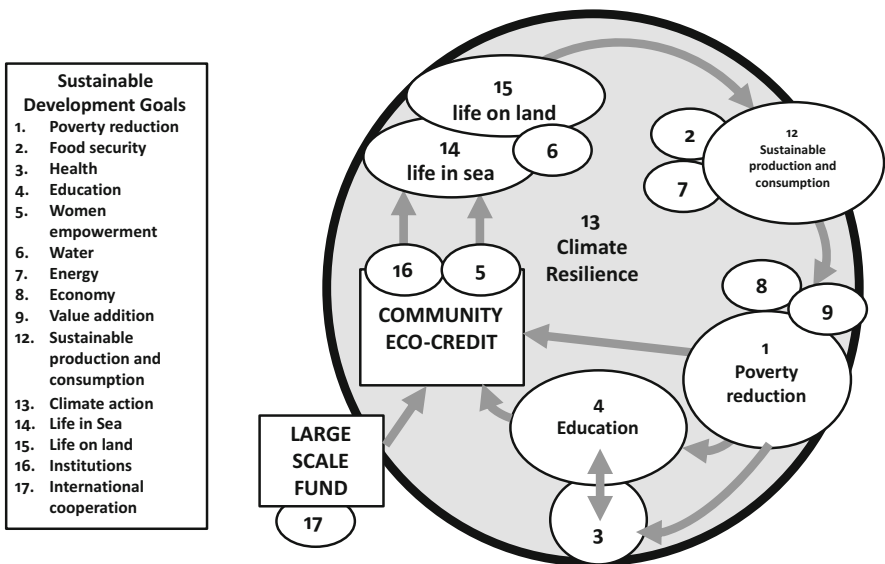
1. Better managing and restoring ecosystems
<i>Leads to:</i>
2. Increased ecosystem productivity:
(a) Increases delivery of ecosystem services (e.g., water, cooling effects, soil building)
(b) Increased quantities of direct ecosystem products (food, fuel, shelter, fiber)
(c) Reductions in labor burden (particularly for women)
<i>Leads to:</i>
3. Improved inputs for household economy, income generation, and business
<i>Leads to:</i>
4. Greater household incomes
<i>Leads to:</i>
5. Household and community investment into:
(a) Education and health
(b) Further ecosystems management
(c) Potentially ecosystem sustainable value chains
<i>Leads to:</i>
6. Better development outcomes:
(a) Food, water, and shelter security
(b) Climate change adaptation and resilience
(c) Climate change mitigation
7. Meeting SDG objectives at community level (Fig. 1)

Inclusive Green Finance (IGF) defined by Schuite and Forcella (2015) as a financial sector that aims to support sustainable solutions, green products, and services to poor households and Micro, Small, and Medium-Sized Enterprises (MSMEs). IGF is an area that is receiving increasing policy attention, although mainstream financial institutions are only now beginning to take up the responsibility of climate change action (Alliance for Financial Inclusion 2019), and countries at the early stages of developing appropriate policy tools (Krogstrup and Oman 2019).

In considering the definitions of eco-credit, several points should be noted. Firstly, the contractual actions in the community model are collectively self-determined by the community as part of their ecosystem restoration and management plan and not imposed from outside. The plan is usually facilitated by an NGO (or an agricultural commodity company working with outgrowers (e.g., tea, coffee, and cocoa), and ideally follows best practice and is located within a framework of applicable law. With regard to this framework, it should be noted that the applicable law is not always appropriate and/or consistent and that, for many ecosystems, best practice has not been elaborated, and if elaborated may not be available at the community level. Thus, much additional work is needed in this area of practice. Secondly, credit programs can include both Islamic and interest-based financial models, and so have wide applicability. Thirdly, contractual actions that are undertaken do not have to be limited to ecosystem management or restoration, but can include other environmentally positive actions (e.g., adopting an energy saving stove), or indeed the same principle could be applied to other programs such as

health and education (but without an environmental dimension would not be “eco”). Fourthly, this approach can work alongside social safety net financing (e.g., cash transfers) for the poorest community members and can potentially provide a route out of reliance on government assistance programs. Finally, the eco-credit approach could also be applied to mainstream finance provided through the banking sector, as identified by the International Monetary Fund (Krogstrup and Oman 2019) and applied by banks such as Barclays (undated) that offer credit discounts to homeowners adopting climate-beneficial technologies.

The underlying idealized theory of change (Table 1) is where access to credit at the community level helps to incentivizes behavioral responses to ecosystems management from unsustainable use to long-term stewardship and sustainable use patterns. These changes help develop virtuous cycles of increased ecosystem productivity and community development supporting most of the sustainable development goals (Fig. 1). It will also be important to understand how community credit can act as a behavioral driver that motivates individual and community courses of action. Behavioral determinants can be deeply ingrained and based upon factors like culture, habit, degree of ease, perceived barriers, social norms, or identity, and it will be also ideal to understand what elements of eco-credit might prevent or encourage the adoption of the ecosystem-positive behaviors.



**Fig. 1** Community eco-credit and the Sustainable Development Goals generating a virtuous climate resilient village economy. Development funding supports community eco-credit which supports improved ecosystem management leading to sustainable production and consumption which supports economic development, poverty reduction, and community-level investments in health and education

## Community Environment Conservation Fund

### Background to the Model

The CECF, a focus of this chapter, is an example of eco-credit and was initiated in 2012 in the Upper Aswa sub-catchment in the Northern Ugandan Districts of Lira, Alebtong, and Otuke. It was part of the International Union for Conservation of Nature (IUCN) project Building Drought Resilience through Land and Water Management (BDR). The project was implemented in the basins of the lower Tana River in Kenya and Upper Aswa River in Uganda. The project used IUCN's Resilience Framework – RESFRAM (Smith 2011) and was funded by the Austrian Development Cooperation. It aimed to improve the resilience of dry-land communities to the impacts of severe and frequent drought.

Settlers in the project area were formerly from agro-pastoralist communities, who had settled after over 20 years of disturbance from civil war. Baseline data collected in April 2012 indicated that the newly settled communities were over-exploiting their natural resources to meet immediate survival needs given the limited livelihood options available to them. At that time, the communities' reliance on natural resources was not, however, guided by any significant rules or set practices. Traditional management systems had been eroded during the war and new, statutory ones were only weakly enforced, if at all. As such, the unregulated exploitation of natural resources was leading to their significant degradation, and this degradation was in turn exposing those dependent on this livelihood approach to threats, such as climate change and disease. Wetlands and streams were being farmed right up to, and sometimes even into, the actual channel, and trees were being cut for charcoal, especially, the shea tree (*Vitellaria paradoxa*) which traditionally was protected due to its oil and other benefits. Such actions were increasing the potential for floods and the susceptibility to drought as a result of the reduced quality and quantity of water. Communities were caught up in a vicious cycle where they were both reliant upon, while also degrading, their natural resource base.

### Implementing the IUCN Resilience Framework – RESFRAM

The IUCN RESFRAM approach promotes consideration of the following four components.

1. Diversity of the economy, livelihoods, and nature. Diverse markets or farming systems give women and men the alternatives they need to be adaptive. Enhancing and protecting biodiversity by maintaining, or recreating, natural diversity also ensures the availability of the ecosystem services needed to buffer climate impacts, such as storage of water in vegetated riverine habitats, and sustains life and productivity.
2. Sustainable infrastructure and technology – landscape management that recognizes, encourages, and combines the presence, development, and maintenance of

both engineered and “natural infrastructure,” as well as adaptable, equitable, and sustainable technologies for their management, to reduce vulnerabilities. Infrastructure includes not only engineered responses, such as the sinking of boreholes, but also “natural infrastructure,” such as healthy and functioning wetlands and floodplains that store water, lower flood peaks, or buffer surrounding lands from flooding.

3. Self-organization – a critical characteristic of resilient, highly adaptive communities is participatory governance, and self-empowerment.
4. Learning – ensuring that individuals (women and men) and institutions are availed, and can make use, of new skills and technologies as they become available helping them to make more effective use of information, and thus to develop effective adaptation strategies.

The IUCN team in Uganda examined different options to implement the resilience framework. One approach considered was to support what is often called alternative livelihood activities. In IUCN Uganda’s experience, such alternatives have often been determined by external actors, been very unrealistic and, frequently, not in line with the differentiated livelihood priorities and aspirations of the women and men to whom they are promoted. Another approach considered, common in social safety net programs, was to directly pay people to carry out activities such as tree nurseries and soil conservation practices. This approach meant that extensive project delivery infrastructure would have been needed to deliver and monitor the work, which would not have been efficient nor sustainable. In addition, it would not have strengthened governance at the community level, a key feature of IUCN’s work.

IUCN Uganda consequently developed its own approach that it called the CECF (IUCN 2013). The CECF funding works by providing a grant for the establishment and capitalization of a community revolving credit fund to communities who have collectively agreed to develop and implement an environmental management plan. This means that environmental management work is promoted, undertaken, and monitored by whole communities, including different household compositions, to ensure receipt of the credit facility, but that the money itself can be borrowed and used for any purpose, for example, from paying school fees and hospital and doctors’ bills to investments and other activities. In this way, the provision of the fund delivers improved environmental management because it enables improvements in livelihoods by removing barriers to accessing credit and not by prescribing specific actions. This is more effective than “traditional” conservation funds for alternative livelihoods because livelihood priorities are very dynamic and dependent on the status of a household at any point in time.

## **CECF Principles**

The CECF was based on the Village Savings and Loans Association (VSLA) model (IUCN 2013), developed by CARE International and widely used in northern Uganda as an economic empowering mechanism for communities, and especially



women, to access credit and build a resource base to tackle poverty (CARE 2017, 2019). Although derived from VSLA, the CECF model incorporated variations geared toward enhancing sustainable natural resources management (IUCN 2013). These have made it a unique tool to support climate change adaptation and to catalyze community-level implementation of the resilience framework. The CECF is based on seven key principles:

1. The Community Environment Conservation Fund should enhance natural resources management and governance within the area under consideration.
2. It should promote and be clear on individual and collective incentives and actions.
3. It should enhance self-determination. Conditions for using the fund should not be prescribed but should be acceptable enough to meet general conditions.
4. It should be an all-inclusive system that all categories of society (e.g., including women, younger, and elderly people, women-headed households, Indigenous Peoples) have an opportunity to participate in and make decisions on (conditions should be attainable by all members of society).
5. It should be transparent and highly accountable with both effective rewards and sanctions.
6. It should be linked to local governance systems; local government should provide legitimacy to the system by providing oversight.
7. It should be a revolving fund, sustainable over the long-term, and should be considered as a village social fund, and a permanent community-level asset, designed to attract and catalyze more support.

Self-determination is essential as this stimulates community collective action and ownership, therefore, community land-use plans are not determined by outsiders (Ostrom 1990). In this regard, the approach follows the first principle of the ecosystem approach that the ecosystem is a result of societal choices (Shepherd 2004; CBD 2019). The plans, however, needed to be compliant with local laws and wherever possible be supported by best practice. The project and government facilitators engaged with that process played the role of advising compliance with the legal framework and adopting best practice. It should be noted that the legal framework itself is often outdated, can be contradictory and does not always follow best practice. In the realm of managing complex ecosystems, best practice is itself evolving and sometimes contested.

## **CECF Results**

In the intervening years from 2012 to the present (2020), the CECF has been implemented in three locations in Uganda, the Upper Aswa, the Rwizi River basin in the south-west and Mount Elgon, as well as at individual pilot sites in Malawi, Kenya, and Tanzania. The methodology has generated considerable interest as a scalable, replicable, adaptable, and cost-effective tool with the potential to build the financial, environmental, and social capital of participating communities who are

(i) dependent on natural resources for their livelihoods, and (ii) vulnerable to the impacts of climate change.

As mentioned, the approach has been subject to a number of reviews including Kakuru and Masiga (2016) (for Upper Asswa); Ellis-Jones et al. (2018) for Uganda and Kenya; a World Bank review (2017), and Mott MacDonald Reports (Mott MacDonald 2018a, b) for the Shire basin in Malawi; and Roberts (2017) and Wild (2019) for Pemba Island, Zanzibar, Tanzania.

In Malawi, the Ministry of Agriculture, Irrigation, and Water Development with World Bank support and technical assistance from Mott-Macdonald Ltd. have been using CECF to support watershed catchment management in the Shire River basin (Mott Macdonald 2018a, b). This component of the program was operational from 2016 to 2018 and supported the formation of 185 CECF funds. Early indications were positive and the CECF was instrumental in stimulating communities to take up actions in their village land-use plans. The project, however, has subsequently closed and the technical support is no longer in place – a follow-up is therefore recommended to assess how these are progressing and if they have survived the post-project cessation of technical support. In Pemba Island, the system has been tried for the first time with marine communities. Here GreenFi System Ltd. is supporting a Tanzanian NGO Mwambao Coastal Community Network to apply a modified approach with the members operating in groups of 30, with more specific environmental commitments, and using mobile phone technology for tracking. In this case, the background situation was examined in detail (Roberts 2017). A recent review indicated that the groups in the pilot community are progressing and the approach is appreciated at the community level (Wild 2019).

Of these reviews, the most exhaustive was Ellis-Jones et al. (2018) for Uganda (Lira, Mt. Elgon, Rwizi) and Kenya (Garissa and Tana River), and has been drawn upon to provide more detail. The overall purpose of that report was to assess the verifiable impact of the CECF approach to (i) inform design and implementation of systems which strengthen the CECF methodology in order to create a robust platform and credible basis for scale-up, and (ii) help build a richer story for IUCN to communicate the success and potential of the CECF methodology to potential funders.

The importance of a scalable methodology and credible financial, environmental, and social impact reporting is to (i) demonstrate return on investment for investors in a hybrid market-based/donor-funded model, (ii) show the cost-effectiveness of the CECF methodology in a crowded market-place for conservation concepts, and (iii) maybe most importantly, give IUCN management enhanced control over CECF implementation and performance such that the scaling is efficient and effective – and the methodology continues to be effective at scale. The review was constrained in terms of reporting impact by the lack of an impact monitoring protocol in the CECF Guidelines, particularly for assessing *verified* environmental and social impact. Financial data were available at project sites, however, but again there was no uniform methodology for loan tracking in the CECF Guidelines.

## External Funding for CECF Groups

In terms of the review result, and most importantly, there appears to be a compelling case that community credit groups can be seeded with outside funds and, with the correct external mentoring, successfully manage this fund injection as a revolving credit facility. This is an important finding because the more established Village Savings and Loan Association (VSLA) methodology does not encourage group seeding with capital that has not been provided by the group members themselves, which has been a threat to the assumptions which underpin the CECF model. In discussing this with CARE, this contributes to the risk that group formation is principally for the purpose of receiving funds, a problem that is frequently encountered (Pennoti, pers. comm.).

However, it is important that external support and mentoring is maintained for groups in the initial phases and until such times that groups can be graduated. In Mt. Elgon, apparently most groups are inactive, and this appears to be because CECF was used as an exit strategy from a project site. This demonstrates that the CECF methodology requires patience in nurturing and developing groups to a point where they are self-sufficient in managing themselves. Further experiments are needed to uncover how much supervision and for how long groups need this support in order to stabilize, and at what time they can be graduated and where both loan cycles and improved ecosystem governance can continue independently and with low or no external support.

## Verifiable Financial, Environmental, and Social Performance

In the Ugandan project, (i) groups were relatively large (with approximately 200 borrowers per group, although not all group members used their borrowing rights), and (ii) loan size were relatively small (average size US\$15 to 16.50). Loan size was likely a function of group size and fund caps, whereas loan size should ideally be informed by a credit needs analysis during project design, which in turn informs the fund cap. In Garissa, Kenya, average loan sizes were close to what would be expected for unbanked individuals (US\$113 for individual loans), however the Garissa project was still at an experimental stage having recently transitioned from individual loans to “group loans,” a move that itself needs further analysis.

Across key sites (Lira and Garissa), late repayments were relatively low (92% of loans repaid within 5 days of the due date). However, defaults were not tracked. This was partly because group enforcement was good, and loans were marked as repaid, even though they were repaid through the sale of a borrower’s assets, which is technically a default.

It was found that groups are willing to accept environmental conditionality as a term for loan access, but it was unclear the extent to which they complied with these terms later. Nonverifiable forms of evidence suggest that compliance is good, with reports of riverbank and stream protection, tree protection and planting, and numerous ecosystem governance institutions forming, but a robust environmental

monitoring methodology is needed to verify these perceptions. CECF environmental obligations are quite complex, and likely impose both a financial and cognitive burden on members, which may act differently across age and gender groups. It is unclear what impact simplification of CECF-access terms may have in terms of boosting compliance, but once robust monitoring mechanisms are in place this can be tested.

The VSLA methodology, upon which CECF draws, was established to create positive social impact. And over decades, the approach has proven its value. The CECF methodology is new by comparison to VSLA – and offers a different value proposition in terms of social impact: improved welfare through improved natural resource management (as well as access to credit). This makes demonstration of the CECF impact very important, and the review recommended that the CECF Guidelines should include a robust social impact monitoring methodology to demonstrate its proposition.

Gender equity was largely achieved in CECF as inferred from the financial data. This was a good achievement given that there is no clear protocol to achieve this in the CECF Guidelines. Best practices need to be codified to ensure they are replicated in scale-up. Anecdotal reports which are quite widespread that CECF helped reduce the domestic violence by allowing women to have an independent source of income needs further research and analysis.

## **CECF Conclusions**

Overall, the CECF was seen to be successful and hold significant promise but requires higher early years' investments to achieve stability before groups are graduated. Ongoing support is likely to be necessary for groups to sustain action. As yet, how this is provided is not clear. Overall the CECF was seen in the review to be:

- Generally successful and popular with communities. There has, however, been one failure where the scheme was used as an exit strategy at Mount Elgon. With no follow-up support, it did not become rooted and the vast majority of groups did not survive long.
- Environmental monitoring, however, has not been strong, with general anecdotal reporting of environmental gains and no systematic collection of environmental data.
- The model has evolved in different ways in different locations (Rwizi and Garissa).

It has now been tested with agro-pastoralists, pastoralist, smallholder farmers, and coastal fishers, as well as part of catchment management, and using both interest-based and Islamic finance models in three sub-Saharan African countries and with some additional key elements is ready for scale-up.

## Other Community-Level Financial Infrastructure for Climate Change Adaptation

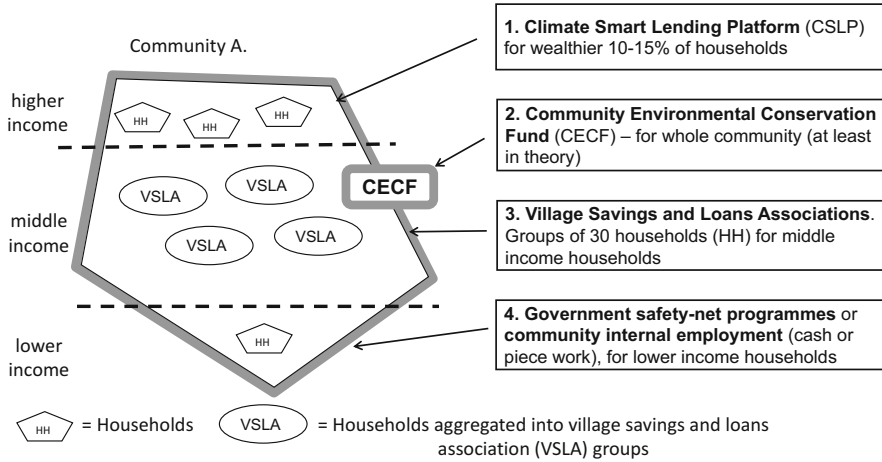
In this chapter, we have identified how this work can be located within a comprehensive financial infrastructure of complementary approaches for ecosystem governance at the community level. These existing complementary approaches that could work very effectively together are set out below and illustrated in Fig. 2. The key components of the model financial infrastructure at the community level to promote stewardship are:

- Community eco-credit (e.g., Community Environment Conservation Fund, the focus of this chapter)
- Commercial eco-credit (e.g., Climate Smart Lending Platform)
- Savings groups (e.g., Village Savings and Loans Associations)
- Value chains that support ecosystems (e.g., sustainable agriculture, forestry, fisheries, and tourism)
- Government social safety nets (e.g., work programs or cash transfers) and internal community labor

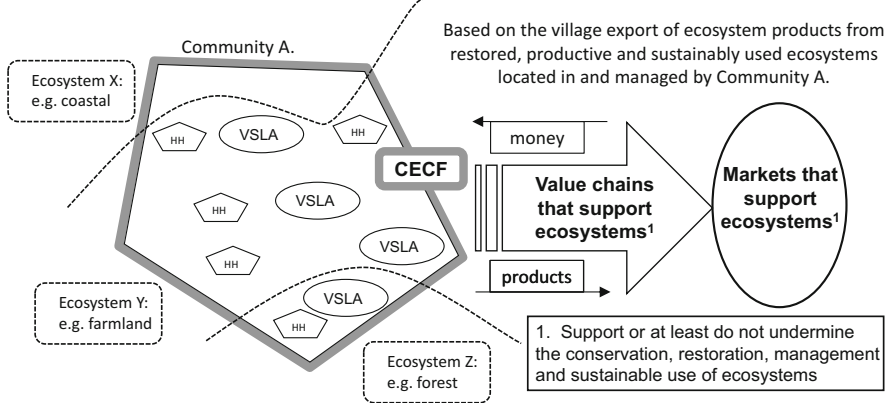
### The Climate Smart Lending Platform

The Climate Smart Lending Platform builds eco-credit into the loan terms of commercial microfinance lenders that typically address the credit needs of the better off 10–20% of community members within a specific community. (This rule of thumb depends on the extent to which households are embedded in paper-trailed supply chains. For example, a pastoralist might be richer than a small farmer on half an acre. But because the farmer is selling into a paper-trailed supply chain, she will be able to attract credit and the pastoralist may not.) The Climate Smart Lending Platform is, therefore, commercial eco-credit, and works with microfinance banks to incorporate climate-smart agricultural and land-management practices into loan terms. When a client signs a loan agreement, they also sign a land management agreement which requires the client to manage their land in a way which is designed to protect them and their farm from climate change-related events. This approach is designed to enhance credit-provider profitability by reducing credit default risk and increasing the client debt service coverage ratio. Additionally, it ensures farmers are building resilience to weather events associated with climate change (Climate Policy Initiative 2015; Partnership for Forests 2018). A successful proof of concept trial with 75 farmers was carried out in the Nyandarua county of Kenya, in 2015. It complements community eco-credit (e.g., the CECF) as it works with the better off members of the community. The two approaches have yet to be tested in the same location.

**a** Showing households and groups in three income levels in one community and four inclusive financial models that could productively be aligned to incentivise ecosystem management



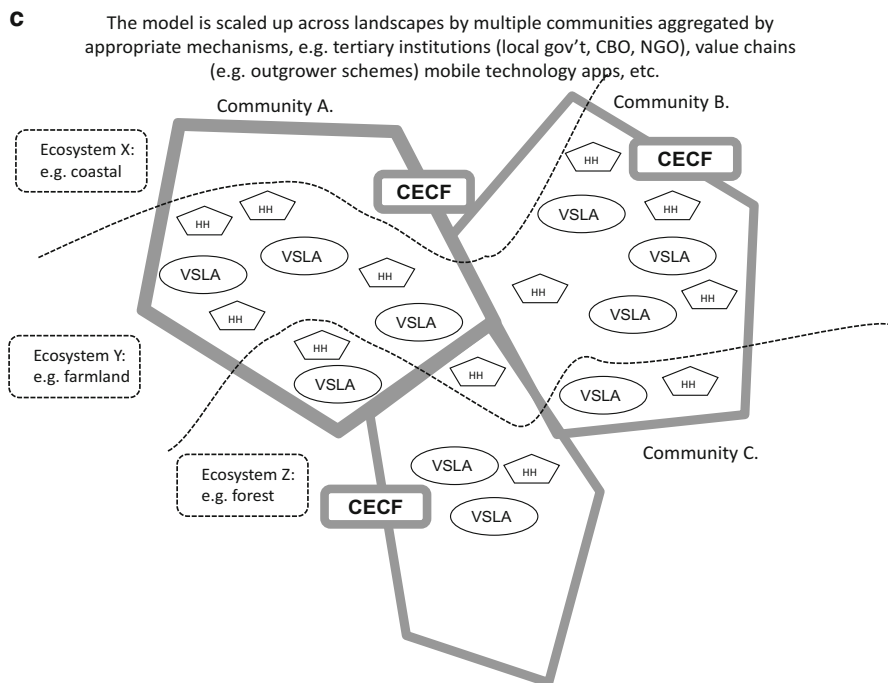
**b** Showing outflow of sustainably produced ecosystem goods into value chains and markets, that support / do not undermine ecosystems, including sustainable agriculture, fisheries & forestry, etc.



**Fig. 2** (continued)

### Village Savings and Loans Associations

CARE International, the leading proponent of savings-based social lending, created the Village Savings and Loans Associations (VSLA) model in Niger in 1991, and has since brought VSLA programming to many different regions and continents, adapting it to different contexts as its reach expands (CARE 2017). Thus, this is a tried, tested, and now massively scaled savings-led, community-based financial solution. CARE deliberately set out to scale it up in 2009, and has since expanded access to from an initial 1 million members in 2008 to 7.6 million across 51 countries



**Fig. 2** A comprehensive and complementary inclusive of green financial infrastructure for ecosystem restoration at community level, showing (a) socio-economics, (b) value chains, and (c) landscape scale-up

today. These members represent 357,000 groups of predominantly rural, poor women collectively saving and investing over US\$500 million per year (CARE 2019). CARE's investment in growing VSLAs and its broad-based industry engagement has allowed it to significantly multiply its impact; more than 26 other NGOs and several governments are implementing savings group programming at scale modeled on VSLA. This work has resulted in over 15.2 million VSLA members world-wide who are saving and investing in their respective communities (CARE 2017). 59% of CARE-trained VSLA members are in East Africa, 17% in West Africa, 13% in Southern Africa, 10% in Asia, and 1% in Latin America. There have been many studies on the impact of VSLA including randomized trials (e.g., Ksoll et al. 2016). These studies of VSLAs have found evidence of significant positive outcomes, including the number of meals consumed per day, household expenditure, and the number of rooms per dwelling. This effect is linked to an increase in savings and credit obtained through the VSLAs, which has increased agricultural investments and income from small businesses (Ksoll et al. 2016). While some attempts at greening VSLA have been made (Wild et al. 2008), the model has primarily focused on the social and financial double bottom line (Pennotti, pers. comm.). The VSLA financial infrastructure is now widespread and deeply embedded at community level

and presents a huge foundation for scaling eco-credit if environmental actions can be integrated into group actions. To take one example, the northern Zanzibar Island of Pemba has over 90 VSLA trainers organized through a formerly CARE supported local NGO Pemba Savings and Credit Association (PESACA) (Wild 2019) could support the evolution of eco-credit. The VSLA model was the basis for the CECF innovation.

## **Sustainable Value Chains**

The restoration and better management of ecosystems and the increased ecosystem productivity it brings will of itself enhance community livelihoods. However, the more that these are linked in with value chains that support and do not undermine these ecosystems from which they derive products, the greater the livelihood and income generation benefits will be generated. Further, the increase in community incomes is likely to increase the pace of scale-up and improve the chance of engaging the private sector in climate change adaptation. Many agricultural, forestry, fisheries and tourism-based value chains could fit into this category. The advantage of the eco-credit approach is that it is very scalable, overcoming the geographical scale limit of individual value chains. If tea, coffee, shea nut, sustainable forestry and agriculture companies all took a community eco-credit approach, they would not only green their value chains, but collectively would have significant climate change adaptation impact over wide areas. The recommendation is, therefore, that these commodity companies adopt a community eco-credit approach to support their communities of outgrowers with setting up and capitalizing community eco-credit funds. In addition to securing their produce value chains through sustainable land management, the commodity companies would enhance their social license to operate. Following the lead of the major land-based commodities, this could be replicated among the less organized agriculture, forestry and fisheries-based value chains.

## **Social Safety Net Funding and Internal Employment**

A common feature in many societies are payments to vulnerable households via government social safety net systems. This is a broad topic and the purpose of highlighting it here is that (a) if these safety nets were aligned with ecosystem management and restoration and (b) if VSLA and CECF are recognized as potential routes out from the need of social safety nets, then funding would align for greater impact. The internal use of employment and piece work within communities is also common, where better off community members employ less well-off community members in activities such as digging land, collecting water, and firewood (Whiteside 2000). We expect internal employment to be an integral feature of community financial infrastructure that we outline supporting profitable climate adaptation activities, however, this requires further research.



## Scaling Up Community Eco-credit

As eco-credit is relevant to most rural communities in the global south, and it has a very significant scale potential to assist communities to adapt to and mitigate climate change. We briefly outline here two elements that will be important for scale-up: (a) technology platforms and (b) large-scale funding, for example, a blended finance fund.

### Technology: Mobile Phone and Web-Based Applications

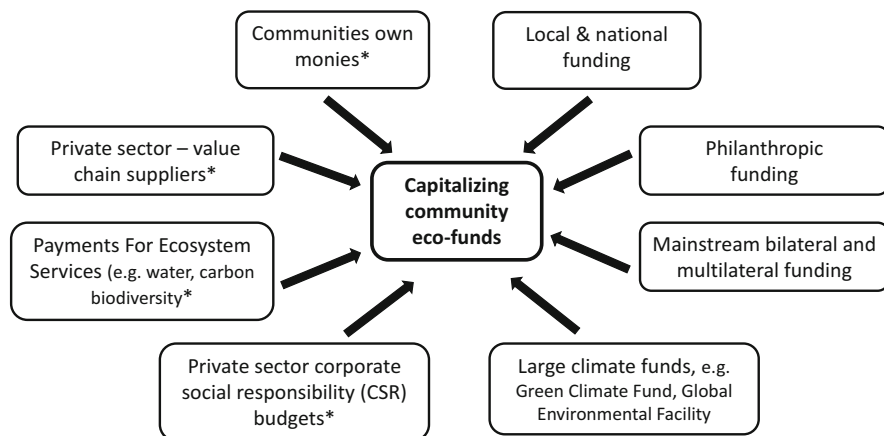
For community eco-credit systems to scale-up effectively, technological solutions will be required. Indeed the 20,000 member strong CECF in Northern Uganda has probably reached the maximum scale possible on an analog system alone. Technology allows scale-up as it reduces the costs of the credit transactions, allows detailed monitoring of both financial and environmental performance, and allows organizations both using and providing grant finance to have real-time reporting on the use and impacts of their funding. These technology systems should include the following key elements:

- Core banking systems
- Environmental monitoring and verification
- Additional elements that will be developed in time
  - Upload community land-use and action plans
  - Boundary and way marking
  - Baseline ecological conditions
  - Baseline social conditions
  - Loan use and effectiveness – enterprise tracking
  - Extension and information via training modules and push SMS
  - Impact at social level – attribution to education and health outcomes

### Establishing Large-Scale Funding

A barrier to the significant scale-up of community eco-credit is the capitalization of community eco-credit funds (e.g., CECF and similar). It is estimated that the resources required for each independent community-level eco-fund is in the range of US\$1,500 to US\$10,000 depending on the socio-economic baseline. There are good reasons to develop dedicated funding mechanisms to capitalize the community-level eco-funds.

IUCN, CARE International, and GreenFi Systems Ltd. developed a concept for a US\$1-2 billion fund which was submitted to the 2019 and 2020 calls for the Global Innovation Lab for Climate Finance. The concept, called MaliVerde MaliBulu – meaning green wealth/blue wealth, was among the finalists, indicating that the creation of a specific fund vehicle could potentially gain traction (IUCN 2019).



**Fig. 3** Potential sources for capitalizing community eco-funds most of which could be channeled through a blended finance vehicle (\*denotes private sector)

The goal of the fund was to establish a US\$2 billion, 10-year fund to capitalize community eco-credit groups, with the aim of restoring the ecological function and carbon sequestration over large areas of land and seascape. If such a fund was successfully established, then community-level; eco-funds could be replicated in different geographies and targeting specific resources and livelihoods (pastoralism, agriculture, fishing, etc.). If US\$2 billion, for example, were deployed into a fund or funds, it was considered that this would scale by 300% in 10 years, and 6,000% in 30 years, meaning 150 million small-scale producers in a decade, and (feasibly) a large proportion of unbankable small-scale producers globally would have access to capital and be contributing to nationally determined contributions (NDCs) to the climate emergency. As it is primarily focused on unbankable community members, the fund would need to adopt a blended finance mechanism, with development partners and aid agencies and large-scale climate financing providing a substantial grant element. The private sector would come in progressively as the groups became either part of an existing value chain (tea and other commodities), or established by a project finance model where the development finance absorbed the risk but the established funds being paid for by the private sector entity. The potential sources of resources and co-resources to establish the community eco-funds can be seen in Fig. 3.

## Discussion

### Scale Relevance of Community Eco-credit

Dalberg (2012, 2016) identifies that only 10–20% of the 450 million smallholder farm households (representing 2 billion people) receive commercial loans mostly through short-term trade finance, through export-based commodity value chain actors (e.g., tea, coffee, etc.). The authors outline the importance of this group not only to delivering food security (SDG 2) but also as ecosystem stewards (SDG 14 and 15).

*Donors consider the world's 450 million smallholders a linchpin in poverty-reduction strategies because more than two billion of the world's poorest live in households that depend on agriculture for their livelihood. These smallholders also represent stewards of natural resources that are in need of sustainable management to prevent deforestation and degradation of ecosystems* (our emphasis). (Dalberg 2012)

The authors identify the opportunities of working with this group but point to a further set of challenges:

- Smallholder production (<2 ha) is low quality with poor market linkages and little finance. Unmet global smallholder finance is estimated at US\$450 billion.
- Agricultural “social lenders” satisfy less than **2%** of the demand.
- The vast majority of smallholders are **nonaggregated** only about 10% of smallholders currently belong to producer organizations.

The authors also note the contribution of VSLA as to informal finance (Dalberg 2016).

In a similar analysis, Verdone (2018), focusing on forest resources, also identified the often-overlooked economic potential of what is possibly the world's largest private sector. He reported estimates that “*more than 1.5 billion smallholders throughout the world depend on forest landscapes to produce food, fuel, timber and non-wood forest products to meet their subsistence needs and generate cash income. Despite the large number of smallholders and the large collective scale of their production, policy makers have overlooked smallholders' role as a powerful economic engine*” (Verdone 2018). If small-scale fishers are added, this number is likely to increase. This group constitutes the largest private sector although they are typically not considered so within the government policy of a number of countries. The Dalberg (2012) report identifies five primary growth pathways for deploying investment to address the current vacuum in smallholder finance:

- (i) Replicate and scale existing financing models, such as the model proven by social lenders
- (ii) Innovate new financial products beyond short-term export trade finance
- (iii) Finance out-grower schemes of multinational buyers in captive value chains
- (iv) Finance through alternate points of aggregation in the value chain
- (v) Finance directly to farmers

### **Advantage of Community Eco-credit**

We consider that the community eco-credit model could become a widespread additional tool in the financial toolbox that could influence several of these growth pathways because:

1. It incentivizes the stewardship of ecosystems and natural resources and supports the increased productivity of and income from these ecosystems and natural resources. This structure support changes in behavior leading to better ecosystem and livelihood outcomes for communities.

2. It aggregates farmers based on ecosystem/natural resources type and not primarily on value chains (although value chains do flow out of this ecosystem-first approach).
3. It is based on rights holders looking for partners – not capital looking for resources and labor (see below).
4. It provides, through grants to communities, the ability for smallholders to take loans and build up credit history.
5. By linking eco-credit group capitalization, it would also incentivize the greening of local business development.

Community eco-credit therefore provides one route for unbankable community members to develop a credit score, such that eventually, and with appropriate duty of care, they can bear a commercial loan, necessary to finance, for example, more expensive climate mitigation or adaptation technologies.

### **Aggregation for Ecosystem Management**

In the eco-credit model, aggregation is via community institutions, not to meet the needs of a value chain of a commercial entity, but to better organize effective ecosystem restoration and management, and enhance ecosystem productivity. It comes from a different basis identified as “*investing in locally controlled ecosystems (e.g., forestry)*” (Elson 2012), representing a paradigm shift – away from capital seeking ecosystems and needing labor – toward local rights-holders managing ecosystems and seeking capital. It recognizes the need to distinguish and blend two types of investment:

- Asset investment (conventional investment in which the nominal value of underlying capital is expected to increase or at least not fall)
- Enabling investment (in which capital is foregone to build the self-sufficiency and attractiveness of the business in question)

---

### **Conclusion and Recommendations**

The increasing recognition of the unfolding climate emergency has increased the urgency for public and private investment in ecosystem management and restoration as a key adaption and mitigation mechanism. Globally small-scale producers; fishers, foresters and farmers/pastoralists are the largest single group of stewards and primary investors in these ecosystems. Despite access to credit being a main driver behind adaptation to climate change at the farm household level (Di Falco et al. 2011), these groups are hardly served, and in fact are considered largely unbankable by the formal banking sector.

There is a great need therefore to find ways to fill this vacuum and bring inclusive finance for climate change adaptation to these communities. The CECF case study described here, using the concept of eco-credit, builds on the existing solidarity

finance mechanisms which serve this group. It builds climate adaptation and ecosystem management actions into loan terms and incentivizes gender-responsive adaptation and mitigation at the community level, as well as supporting individuals and households. The CECF model has been tested in several locations in East and Southern Africa over 8 years and is ready for significant scale-up. Scale-up will be supported by the development of appropriate technology platforms and the development of a blended finance vehicle to capitalize and provide technical assistance to the eco-credit groups.

Other complementary mechanisms if used in the same location will significantly strengthen the CECF model. These complementary mechanisms include the commercial eco-credit of the Climate Smart Lending Platform, aligned VSLA groups, value-chains that do not undermine ecosystem, and where needed and aligned, social safety net funding. To fully take advantage of this model, we make the following recommendations:

- Scale-up and expand the operation and delivery of local autonomous community eco-credit funds.
- Make funding available to capitalize community eco-credit funds through the creation of large-scale blended finance vehicle (>US\$2 billion) capitalizing this vehicle from multilateral and bilateral programs, carbon credits, private project finance, payments for ecosystem services, and corporate social responsibility.
- Support the development of value chains that support ecosystem restoration and sustainable-use that help communities conserve those ecosystems and support increased ecosystem productivity and poverty reduction.
- Commodity value chain companies with outgrower schemes (e.g., tea, coffee, cocoa, and timber) introduce eco-credit to their communities to enhance sustainable land and ecosystem management.
- Carry out further research into this model, individual, and behavioral responses and provide lessons and pathways for enhanced scale-up, including improved mechanisms for recording eco-compliance.
- The conservation community to provide more extensive and practical guidance in equitable sustainable management and conservation of ecosystems at the community level to enhance ecosystem productivity for local wealth generation.
- Explore the use of community eco-credit to support PES and REDD+ schemes.

**Acknowledgments** Appreciation goes to the Austrian Development Cooperation for funding the Building Drought Resilience project where CECF was developed.

---

## References

- Alliance for Financial Inclusion (2019) Inclusive green finance: a survey of the policy landscape. AFI special report. Alliance for Financial Inclusion. <https://www.afi-global.org/publications/3036/Inclusive-Green-Finance-A-Survey-of-the-Policy-Landscape>
- Andrews J B, Caro T, Said Juma A, Collins A C, Bidawa Bakari H, Hassan Sellieman K, Abdi M, Assaa Sharif N, Borgerhoff Mulder M (2020) Does REDD+ have a chance? Implications from Pemba Tanzania. *Oryx* 54(3):1–7

- Barclays Bank (undated) Treasury Select Committee: inquiry into the decarbonisation of the UK economy and green finance submission by Barclays Bank. <https://home.barclays/content/dam/home-barclays/documents/citizenship/our-reporting-and-policy-positions/policy-positions/Treasury-Select-Committee-Barclays-Green-Finance-Inquiry.pdf>
- Börner J, Baylis K, Corbera E, Ezzine-de-Blas D, Honey-Rosés J, Persson UM, Wunder S (2017) The effectiveness of payments for environmental services. *World Dev* 96:359–374. <https://doi.org/10.1016/j.worlddev.2017.03.020>
- Brockhaus M, Korhonen-Kurki K, Sehring J, Di Gregorio M et al (2015) Policy progress with REDD+ and the promise of performance-based payments: a qualitative comparative analysis of 13 countries. CIFOR working paper 196, Bogor Indonesia
- CARE International (2017) CARE Global VSLA Reach 2017: an overview of the global reach of Care's Village Savings and Loans Association programming. <https://insights.careinternational.org.uk/media/k2/attachments/CARE-VSLA-Global-Outreach-Report-2017.pdf>
- CARE International (2019) Unlocking access, unleashing potential: empowering 50 million women and girls through village savings and loan associations by 2030. CARE, Atlanta
- Clements T (2010) Reduced expectations: the political and institutional challenges of REDD+. *Oryx* 44(3):309–310
- Climate Policy Initiative (2015) Climate smart lending platform. <https://www.climatefinancelab.org/project/climate-smart-finance-smallholders/>. Last accessed 19 Sept 2019
- Convention on Biological Diversity (2019) The ecosystem approach. <https://www.cbd.int/ecosystem/principles.shtml>. Last accessed 19 Sept 2019
- Dalberg (2012) Catalyzing smallholder agricultural finance. Dalberg Global Development Advisors, New York
- Dalberg (2016) Unlocking growth in the era of farmer finance. Dalberg Global Development Advisors, New York. <https://mastercardfdn.org/research/inflection-point-unlocking-growth-in-the-era-of-farmer-finance/>
- Deering K (2019) Gender transformative adaptation from good practice to better policy. CARE International, Atlanta
- Di Falco S, Veronesi M, Yesuf M (2011) Does adaptation to climate change provide food security? A micro-perspective from Ethiopia. *Am J Agr Econ*:1–18. <https://doi.org/10.1093/AJAE/AAR006>
- Ellis-Jones M, d'E Roberts J, Ngigi ON (2018) A report on CECF financial performance and environmental compliance. Unpublished report for the International Union for Conservation of nature (IUCN) November 2018. GreenFi Systems Limited
- Elson D (2012) Guide to investing in locally controlled forestry. Growing forest partnerships with FAO IIED IUCN the forests dialogue and the World Bank. IIED, London
- FAO & Global Mechanism of the UNCCD (2015) Sustainable financing for forest and landscape restoration: opportunities, challenges and the way forward. Discussion paper. Rome. (This publication is available for download at [www.global-mechanism.org/resources/gm-publications](http://www.global-mechanism.org/resources/gm-publications) and [www.fao.org/forestry/publications](http://www.fao.org/forestry/publications))
- Ferraro PJ (2017) Are payments for ecosystem services benefiting the ecosystems and people? In: Kareiva P, Marvier M, Silliman B (eds) *Effective conservation science: data not dogma*. Oxford University Press, Oxford, UK, pp 159–166. <https://doi.org/10.1093/o.003.0025>
- GEF (2019) Land degradation. <https://www.thegef.org/topics/land-degradation>. Last accessed 19 Sept 2019
- Griscom BW, Adams J, Ellis PW, Houghton RA, Lomax G, Miteva DA, Schlesinger WH, Shoch D, Siikamäki JV, Smith P, Woodbury P, Zganjar C, Blackman A, Campari J, Conant RT, Delgado CP, Gopalakrishna ET, Hamsik MR, Herrero M, Kiesecker J, Landis E, Laestadius L, Leavitt SM, Minnemeyer S, Polasky S, Potapov P, Putz FE, Sanderman J, Silvius M, Wollenberg E, Fargione J (2017) Natural climate solutions. *PNAS* 144:11645–11650
- IPCC (2019) IPCC special report on climate change, desertification, land degradation, sustainable land management, food security, and greenhouse gas fluxes in terrestrial ecosystems, Intergovernmental Panel on Climate Change published 7 August 2019. <https://www.ipcc.ch/report/srccel/>
- IUCN (2013) Practical guidelines for establishing a Community Environment Conservation Fund as a tool to catalyse social and ecological resilience. IUCN Uganda Country Office, Kampala, Uganda

- IUCN (2019) MaliVerde/MaliBuluu fund concept gains steam. Webstory. <https://www.iucn.org/news/forests/201903/maliverde-malibuluu-fund-concept-gains-steam>. Last accessed 19 Sept 2019
- Kakuru W, Masiga M (2016) Implementation of the Community Environment Conservation Fund (CECF) to enhance forest landscape restoration in Uganda: emerging lessons and recommendations for scaling up. Unpublished report, IUCN Uganda Country Office, Kampala, Uganda
- Krogstrup S, Oman W (2019) Macroeconomic and financial policies for climate change mitigation: a review of the literature. International Monetary Fund working paper 19/185
- Ksoll C, Lilleør HB, Jonas H, Lønborg JH, Rasmussen OD (2016) Impact of village savings and loan associations: evidence from a cluster randomized trial. *J Dev Econ* 120:70–85
- Milbank C, Coomes D, Vira B (2018) Assessing the progress of REDD+ projects towards the sustainable development goals. *Forests* 9:589. <https://doi.org/10.3390/f9100589>
- Mott MacDonald (2018a) Final report component B – catchment management – Lisungwi and Wamkulumadzi. SRBMP, ISP-CM, sub-components B1–B3. Final report to the Ministry of Agriculture, Irrigation & Water Development and Shire River Basin Management Program
- Mott MacDonald (2018b) Final report component B – catchment management – Kapichira and Chingale, SRBMP, ISP-CM, sub-components B1–B3. Final report to the Ministry of Agriculture, Irrigation & Water Development and Shire River Basin Management Program
- Nichols C, Zimmert J, Young D (2019) Degradation of coastal ecosystems: causes, impacts and mitigation efforts. In: Wright LD, Nichols CR (eds) *Tomorrow's coasts: complex and impermanent*. Coastal research library 27. Springer, Switzerland. [https://doi.org/10.1007/978-3-319-75453-6\\_8](https://doi.org/10.1007/978-3-319-75453-6_8)
- Ostrom E (1990) *Governing the commons – the evolution of institutions for collective action*. Cambridge University Press, Cambridge UK
- Partnership for Forests (2018) Climate smart lending platform partnership offers technology and data driven solution for climate resilient agri-lenders and farmers in East Africa. <https://partnershipsforforests.com/2018/12/12/climate-smart-lending-platform-new-partnership-offers-technology-and-data-driven-solutions-for-climate-resilient-agri-lenders-and-farmers-in-east-africa/>. Last accessed 19 Sept 2019
- Pendleton L, Donato DC, Murray BC, Crooks S, Jenkins WA, Sifleet S et al (2012) Estimating global “blue carbon” emissions from conversion and degradation of vegetated coastal ecosystems. *PLoS One* 7(9):e43542. <https://doi.org/10.1371/journal.pone.0043542>
- Roberts J (2017) Silver bullet or red herring?: Are Community Environment Conservation Funds a suitable management tool for building resilience in coastal communities of developing countries? A feasibility study in Pemba, Zanzibar dissertation for the degree of MSc in Ecological Economics School of GeoSciences, Julianne d’Esterre Roberts 1675511 August 2017
- Schuite GJ, Forcella D (2015) Green inclusive finance: status, trends and opportunities! NpM the platform for inclusive finance, Hivos & FMO
- Shepherd G (2004) *The ecosystem approach five steps to implementation*. IUCN, Gland/Cambridge, UK
- Smith DM (2011) Development and application of a resilience framework to climate change adaptation. Global Water Programme, IUCN, Gland
- UNCCD (2019) An impact investment fund for land degradation neutrality. <https://www.unccd.int/actions/impact-investment-fund-land-degradation-neutrality>. Last accessed 19 Sept 2019.
- UNDP (2014) UNDP, Mitsubishi UFJ and Morgan Stanley announce winner of climate change finance innovation award. Dec 9, 2014. <https://www.undp.org/content/undp/en/home/presscenter/pressreleases/2014/12/09/undp-mitsubishi-ufj-morgan-stanley-announce-winner-of-climate-change-finance-innovation-award/>. Last accessed 13 Sept 2019
- Verdone M (2018) The world’s largest private sector? Recognising the cumulative economic value of small-scale forest and farm producers. IUCN, FAO, IIED and AgriCord, Gland
- Whiteside M (2000) Ganyu labour in Malawi and its implications for livelihood security interventions – an analysis of recent literature and implications for poverty alleviation. ODI Agricultural Research & Extension Network, Network Research Paper 99
- Wild RG (2019) A review of the MKUBA pilot in Kuku Village, Pemba, Zanzibar. Unpublished report for Mwambao Coastal community Network and the Fauna and Flora International

- Wild RG, Millinga A, Robinson JR (2008) Microfinance and environmental sustainability at selected sites in Tanzania and Kenya. Unpublished report for LTS, WWF and CARE International
- World Bank (2019) Green climate fund trust fund financial report prepared by the trustee (The World Bank). As of June 30, 2019. <https://fiftrustee.worldbank.org/content/dam/fif/funds/gcf/TrusteeReports/GCFTF-Financial-Report-as-of-June-30-2019.pdf>. Last accessed 19 Sept 2019
- World Bank Group (2017) First Phase of Shire River Basin Management Program (SRBMP) Project: implementation support mission – January 25 to February 6, 2017. Aide Memoire
- WRI (2017) In: Ding H, Faruqi S, Wu A, Altamirano J-C, Ortega AA, Cristales RZ, Chazdon R, Vergara W, Verdone M (eds) Roots of prosperity: the economics and finance of restoring land. World Resources Institute, Washington, DC

**Open Access** This chapter is licensed under the terms of the Creative Commons Attribution 4.0 International License (<http://creativecommons.org/licenses/by/4.0/>), which permits use, sharing, adaptation, distribution and reproduction in any medium or format, as long as you give appropriate credit to the original author(s) and the source, provide a link to the Creative Commons license and indicate if changes were made.

The images or other third party material in this chapter are included in the chapter's Creative Commons license, unless indicated otherwise in a credit line to the material. If material is not included in the chapter's Creative Commons license and your intended use is not permitted by statutory regulation or exceeds the permitted use, you will need to obtain permission directly from the copyright holder.







# Pathways to Enhance Climate Change Resilience among Pastoral Households in Northern Tanzania

# 126

Ronald Boniphace Ndesanjo, Ida Theilade, and Martin Reinhardt Nielsen

## Contents

Introduction .....	2592
Study Context and Methods .....	2593
Conceptual Framework .....	2594
Results and Discussion .....	2595
Local Climatic Trends .....	2595
Livelihood Profiles .....	2597
Household Vulnerability .....	2597
Climate Change Adaptive Strategies .....	2601
Local Institutional Mechanisms and Climate Change Resilience .....	2603
Limitations .....	2606
Conclusions .....	2606
References .....	2607

## Abstract

The objective of this study was to evaluate the pathways to enhance resilience to increased climate variability and directional change among pastoral households in Simanjiro District in Northern Tanzania. The study used household survey and rainfall and temperature data. Results indicate increasing temperature

This chapter was previously published non-open access with exclusive rights reserved by the Publisher. It has been changed retrospectively to open access under a CC BY 4.0 license and the copyright holder is “The Author(s)”. For further details, please see the license information at the end of the chapter.

R. B. Ndesanjo (✉)

Institute of Development Studies, University of Dar es Salaam, Dar es Salaam, Tanzania  
e-mail: [ronald.ndesanjo@gmail.com](mailto:ronald.ndesanjo@gmail.com)

I. Theilade · M. R. Nielsen

Department of Food and Resource Economics, Section for Global Development,  
University of Copenhagen, Copenhagen, Denmark  
e-mail: [idadat@ifro.ku.dk](mailto:idadat@ifro.ku.dk); [mrmni@ifro.ku.dk](mailto:mrmni@ifro.ku.dk)

© The Author(s) 2021

W. Leal Filho et al. (eds.), *African Handbook of Climate Change Adaptation*,  
[https://doi.org/10.1007/978-3-030-45106-6\\_128](https://doi.org/10.1007/978-3-030-45106-6_128)

2591

and decreasing precipitation trends over the past four decades. Also, extreme climatic events, particularly drought, have become more frequent. Food and water insecurity are key factors causing an increased household vulnerability. Increased climate change-induced malaria prevalence poses additional health risks. Household adaptive strategies include livelihood diversification and migration. Local institutions are instrumental in enhancing climate change resilience at the local level. We conclude that livelihood diversification and migration are key pathways to enhancing households' climate change resilience.

---

**Keywords**

Adaptation · Agro-pastoralism · Climate change · Resilience · Tanzania

---

**Introduction**

There is a strong consensus that temperatures, based on medium emissions scenarios, are likely to rise by more than 2 °C in most parts of Africa by the end of the century (Orlove 2019). Concomitantly, extreme events such as tropical cyclones, increasing rainfall intensity, and increased probability of drought are gradually becoming common (Kangalawe 2017; Pauline et al. 2017). Climate change impacts are already experienced in many locations (Pardoe et al. 2018). At a local level, these changes are manifested in many ways including shifts of rain seasons, erratic rains, extreme droughts and precipitation, strong winds, and higher temperatures (Berkhout 2012; Suckall et al. 2014). These changes have brought about adverse livelihood impacts such as reduced crop yields and changes in the crop calendar (Berkhout 2012; Mertz et al. 2009).

Climate change vulnerability is considered higher in developing countries due to particular socio-economic and ecological conditions that increase people's exposure to risk factors and reduce the adaptive capacities. Extreme events such as droughts and floods increase particularly rural livelihoods vulnerability because they rely more on climatic conditions (Sewando et al. 2016). Observed and projected changes in local climate conditions in Tanzania include precipitation variability increasing between 5% and 45% accompanied by a temperature rise of 2–4 °C (Trærup and Mertz 2011). The northern part of the country is reported to have undergone a shift in the onset of rainfall between 1980 and 2004 (Trærup and Mertz 2011). Associated with these changes are extreme events such as floods and a rise in human, crop, and animal diseases. Together, these changes adversely affect crop, mobility, and migration patterns among rural communities (Rodima-Taylor 2012).

The livestock sector in sub-Saharan Africa faces negative impacts of climate change (Suryabhagavan 2017). In Tanzania, livestock husbandry faces higher risks from these impacts associated with altered productivity in rangelands. Reduced productivity may adversely affect pastoral livelihoods and the economy of the entire livestock sector in the country. Apart from pastoral communities, the general population is likely to be negatively affected through high reliance on food products from grazing animals (Godber and Wall 2014).

Pastoral vulnerability will be further exacerbated by other livelihood stresses that characterize rural livelihoods. This includes high population growth in the context of a declining and highly dynamic resource base in Simanjiro District (Woodhouse and McCabe 2018; Lynn 2010). The combination of these effects with stressors ranging from short term drought and extreme precipitation events to long-term climatic shifts is likely to reduce further pastoralists' ability to sustain their current livelihoods system. The aim of this study was, therefore, to evaluate pathways to enhance resilience to increasing climate variability as well as directional climate change among pastoral households in Simanjiro District, Northern Tanzania. The study sought to answer four main questions: (a) What are the climate patterns and trends in the study area? (b) What is the status of household vulnerability to impacts of increasing climate variability and directional climate change? (c) What are the adaptive strategies employed by pastoralists in the study area in response to increasing climate variability and directional climate change? (d) What is the role of local institutions in enhancing the resilience of pastoral households to increasing climate variability and directional climate change?

---

## Study Context and Methods

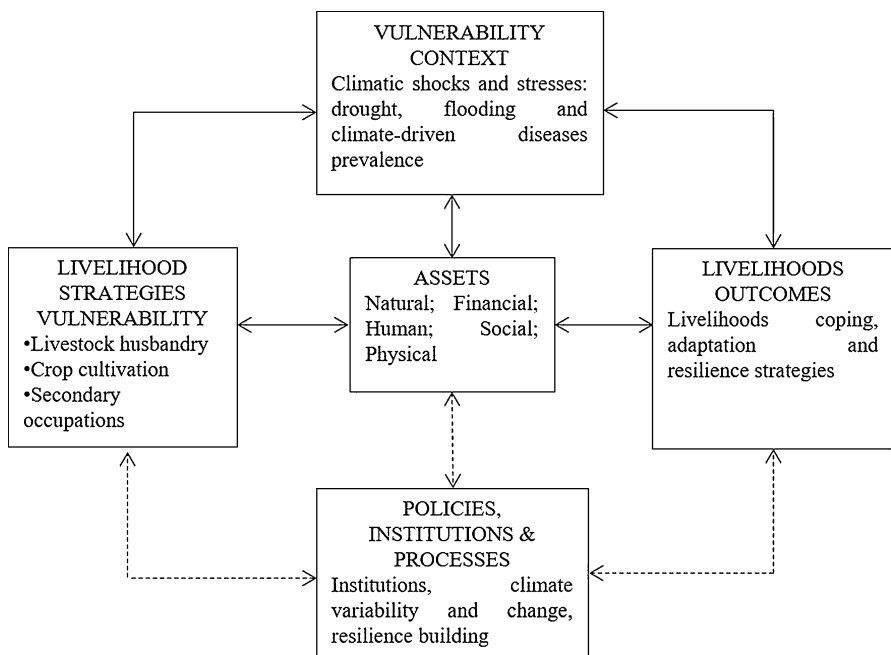
Covering an area of 20,591 km<sup>2</sup>, Simanjiro District is located in Manyara Region of Northern Tanzania. The area's topography stretches from vast plains to scattered ridges and hill valleys. Climate is semi-arid with annual rainfall ranging between 650 and 700 mm. Rainfall is bimodal with short rains lasting from November to December and long rains from February to May. Temperatures range between 13 °C and 30 °C characterized by cold months from May to July and hot months between August and February (Homewood et al. 2009; Pittiglio et al. 2012). Livestock husbandry is common in drier areas while agro-pastoralism is predominantly practiced in wetter areas (Baird and Leslie 2013). The Maasai is the dominant ethnic group in the district, herding livestock of mainly indigenous stock (90%). Maize, beans, pigeon peas, wheat, and sunflower are the main crops grown for both commercial and consumption purposes (Baird and Leslie 2013).

The study used multiple data sources and data collection methods. Study wards were selected purposively based on the predominance of livestock production as the main occupation. Also, ward-specific factors such as livelihoods-ecological interlinkages were used to determine study wards. Household questionnaire surveys were conducted in eleven villages selected in four wards, namely, Endonyongijape, Emboreet, Loiborsiret, and Langai. Random sampling was used to select households targeting the household head. Key informants were selected using purposive sampling (Angelsen et al. 2012; Baird 2014). Household surveys were conducted between May and July 2014. Three aspects were used as measures of household vulnerability to climate change and respective adaptive strategies. These include food, water, and health. Food and water were assessed in terms of their availability (or lack thereof) and health situation was assessed in terms of the prevalence of climatically driven diseases. Adaptive strategies were assessed based on how

households responded to cases of food and water scarcity as well as disease prevalence. Key informant interviews were conducted between February and March 2015. Household survey data ( $n = 297$ ) and in-depth interviews ( $n = 24$ ) were analyzed using descriptive statistical analysis. Monthly precipitation and temperature data were acquired from the Tanzania Meteorological Agency (TMA). Trend analysis was used to analyze climate data.

### Conceptual Framework

This study adopted and operationalized the Sustainable Livelihood Framework (Chambers and Conway 1992) that has been widely used in socio-economic research on a range of topics falling within the poverty, livelihoods, and environment nexus (Reed et al. 2013). The framework offers useful analytical and empirical tools to order information and to understand the nature and interlinkages among livelihood aspects. The framework is built on four main components namely livelihood outcomes, livelihood assets, livelihood strategies, and the institutional context (Fig. 1). The institutional context is conceived as a crucial factor for sustainable livelihoods and for promoting local-level climate change resilience. For livelihood outcomes, the focus is on the household’s vulnerability and



**Fig. 1** Sustainable livelihoods framework. (Source: Adapted and modified from Chambers and Conway 1992)

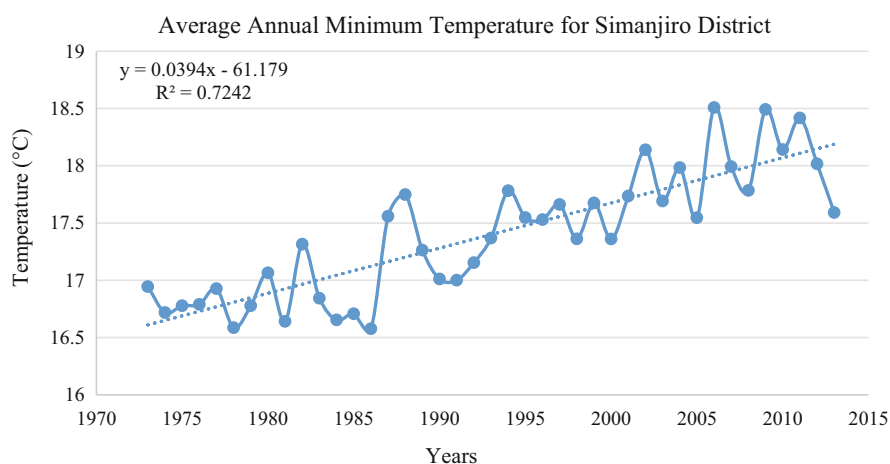
responsive adaptation strategies. All four aspects are embedded in a vulnerability context as it is influenced by climate stressors and shocks.

The study was structured around local socio-ecological contexts that influence key livelihood strategies among study households. The policy environment and local resource management processes formed the institutional context. The vulnerability context is addressed by looking mainly at climate shocks adversely affecting household livelihoods, including drought, flooding, and diseases. These aspects are embedded in the four research questions of the study.

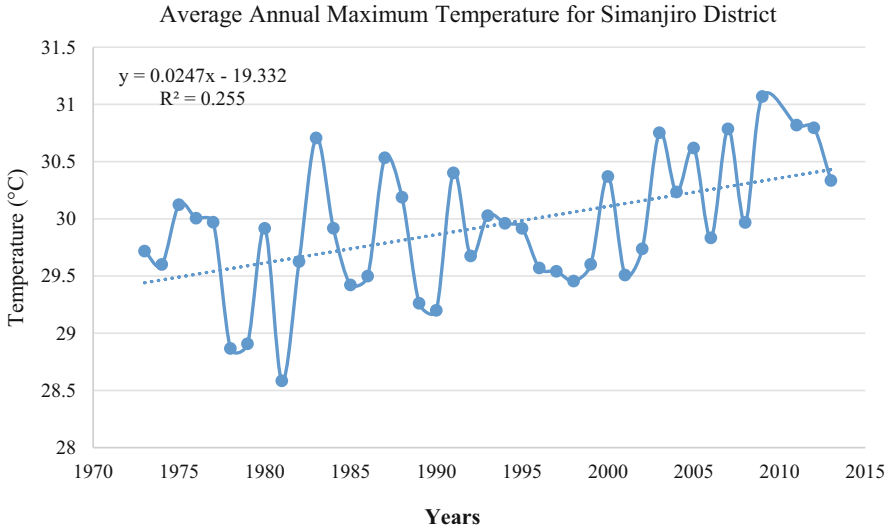
## Results and Discussion

### Local Climatic Trends

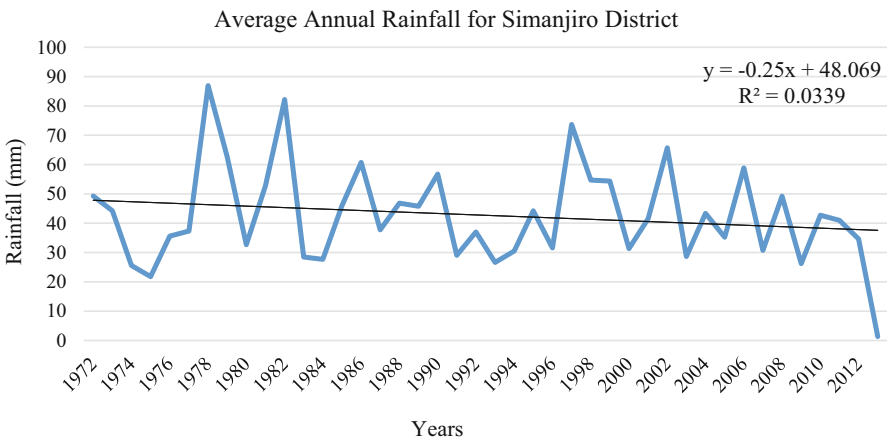
Temperature and rainfall trends are summarized in Figs. 2, 3, and 4. Fitted temperature values indicate an increment in average minimum temperatures of about 2 °C in the period from 1972 to 2013. Data show that the late 1970s to mid-1980s and early 1990s registered lower average minimum temperatures compared to the late 1980s and late 2000s, with relatively higher average minimum temperatures recorded. The average maximum temperature trend portrays a similar pattern with an overall increase in average maximum temperature of about 1.5 °C across the four-decade period based on the fitted line. However, the noted increment in average maximum temperature is statistically insignificant with 25% R-squared. The mid-1980s and late 1990s saw low average annual maximum temperatures. High average temperatures were recorded in the early and late 1980s as well as the first half of the 2000s. The R-squared value for the average minimum temperature indicates a statistically significant (72%) increase in minimum temperature over the 40 years.



**Fig. 2** Average annual minimum temperature for Simanjiro District. (Source: Ndesanjo 2017)



**Fig. 3** Average annual maximum temperature for Simanjiro District. (Source: Ndesanjo 2017)



**Fig. 4** Average annual rainfall for Simanjiro District. (Source: Ndesanjo 2017)

The rainfall trend indicates high average annual rainfall between the late 1970s and 1980s, late 1990, as well as early to mid-2000s compared to the mid-1970s, the first half of the 1980s and 2013 that saw a relatively low average rainfall. Overall, the 40-year data record in the study area reveals a decreasing but statistically insignificant trend in precipitation with an R-squared value of 3%.

Similar temperature and rainfall trends at both the country and continent levels have been noted in other studies such as that by Trærup and Mertz (2011) indicating temperature increase ranging between 2 and 4 °C combined with

increasing precipitation variability on an increasing trend ranging from 5% to 45% in Tanzania. A study by (Pauline et al. 2017) indicates increasing extreme rainfall frequency. However, contrary to observations made in the two studies, the current study depicts a decreasing precipitation trend. Similar predictions were made by Paavola (2008) indicating decreasing precipitation up to 20% by 2100. The year 2013 saw extremely low rainfall, which may overly influence the predicted rainfall trend. However, no substantial difference was noted when omitting the year 2013 from the analysis.

## Livelihood Profiles

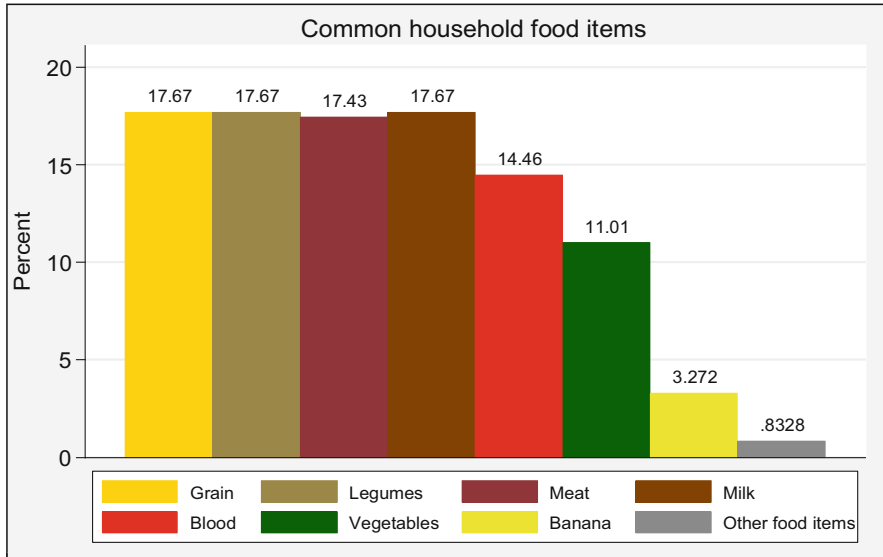
The majority of surveyed households (86%) pursued an agro-pastoralist livelihood strategy. Other livelihood strategies were rare but include trade and wage employment by (3%) and (2%) of the households respectively. Off-farm labor and subsistence herding employ few households each at (2%). About 6% of households reported being engaged in a range of other livelihood occupations.

These results imply that apart from livestock husbandry as the main occupation in the study area, there is increasing adoption of crop farming suggesting a shift to agro-pastoralism as the main livelihood strategy. The increasing common combination of livestock and crop production reflects local communities' strategies to reduce the necessity to sell cattle to acquire food as well as a strategy to safeguard property (land) rights. Other drivers of increasing cultivation in the area include immigration by farming communities, drought, and livestock diseases, as well as government policies aiming to settle the Massai (Homewood et al. 2009). The relatively low percentage engaging in trading and wage employment may be attributed to cultural factors that discourage secondary economic activities. Hence, even when household members engage in secondary income activities, they usually invest the proceeds in livestock and farming (Homewood et al. 2009).

## Household Vulnerability

The percentage frequency of common food items consumed is summarized in Fig. 5. Grain, legumes, meat, and milk contribute equally and constitute about 70% of food items consumed. Vegetables, bananas, and other food items are not commonly consumed.

Grain and milk have been widely documented as common foods in Maasai households (Hodgson 2011; Homewood 2004; McCabe et al. 2010). However, legumes are not common in Maasai pastoralists' diets. Discussions with household members during fieldwork indicate that the inclusion of legumes in their diets is an influence of other ethnic groups that have migrated to Simanjiro in recent years. Particularly, the *Waarusha's* (another Maa speaking ethnic group originating from neighboring Arusha) diet commonly contains legumes (mostly black beans locally known as *ngwara*). Although reported consumed with a high

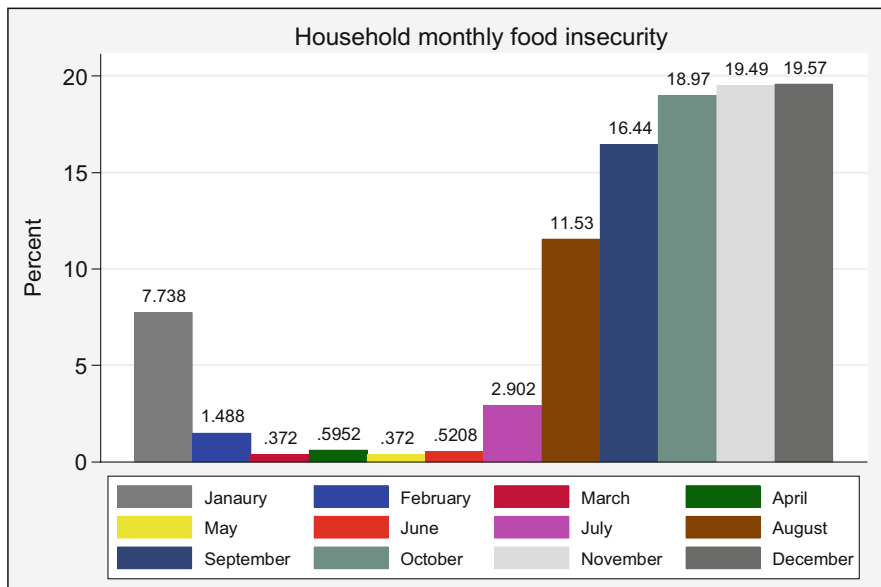


**Fig. 5** Common food items consumed by households (numbers above the bars indicate percentage frequency). (Source: Ndesanjo 2017)

frequency, meat and blood are mainly consumed during special events and ceremonies, for instance, meat-eating feasts among Maasai warriors or initiation ceremonies. Besides, meat is a delicacy consumed at local weekly markets across Maasailand. Maasai rarely consume vegetables or bananas. The few records of these food items are most likely from non-Maasai households. Food consumption patterns depicted here indicate that livestock still is an important food source for most households either directly consumed or indirectly as a means to earn an income with which to meet other food requirements. However, as shown by Berkhout (2012) high dependence on livestock to supply household food requirements can increase climate change vulnerability in the long run.

Households were asked to rate food sufficiency during the previous 12 months and the results are presented in Fig. 6. There is no significant difference across the four wards in household food sufficiency ratings. About 63% reported that they had “somewhat sufficient” food while 29% reported a “somewhat insufficient” food supply during the past 12 months. Only 1% of the households reported a “very insufficient” food supply. Respondents were also asked about experienced incidents of household food insecurity and the exact months in which they occurred. The majority of households (78%) reported experiencing food insecurity between four and six months in the previous twelve months. The months in which food insecurity occurred are described in Fig. 6. These results point to food shortage incidents concentrating in the dry season lasting from August to December. This implies that food security is seasonal deterministic and that vulnerability will likely increase as a result of climate-induced exacerbation of drought in the dry season.



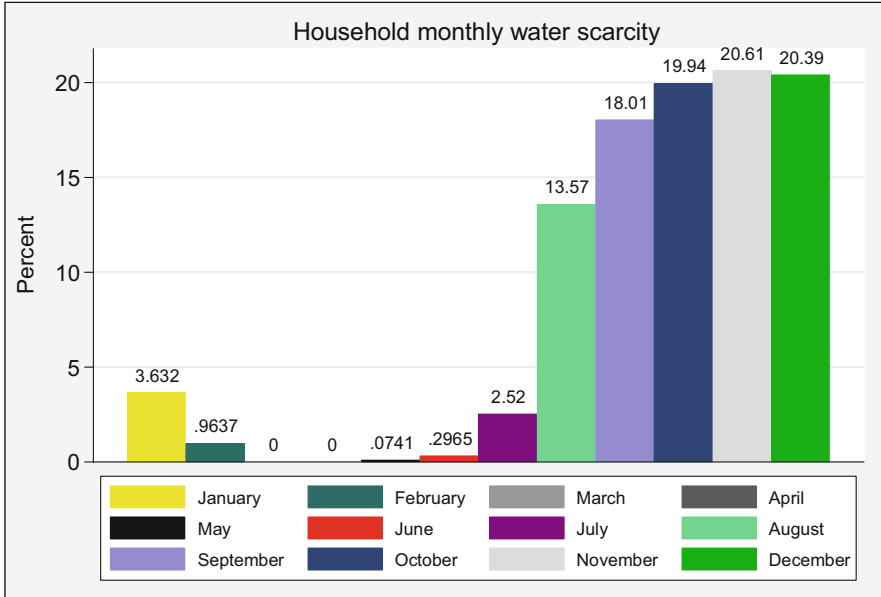


**Fig. 6** Monthly household food insecurity incidents (numbers above the bars indicate percentage frequency). (Source: Ndesanjo 2017)

Water scarcity incidences and when such incidences occurred were recorded as a measure of household water security. About 98% of households rely on boreholes and dams as their main water source. Only 2% of households noted rain (harvesting) as a source of water for households. Household water sufficiency rating reveals that the majority of households (83%) considered water “somewhat available.” Only 4% of households reported that water is “sufficiently available.” About 13% considered “scarcely available.” No significant difference was noted between wards. Duration wise, the majority of households (80%) reported experiencing water scarcity up to six of the previous twelve months. The months in which water scarcity incidents were experienced are presented in Fig. 7.

Several inferences can be made from these results. Firstly, most households have insufficient water available to meet year-round demand. Secondly, water scarcity coincides with the dry season indicating high seasonal household dependence on climate-sensitive water sources including rain-charged dams as well as groundwater. Thirdly, as many households rely on boreholes for their water requirements, financial constraints could affect their ability to access life-essential water.

In a study that examined the economic and environmental change in Niger, McKune and Silva (2013) linked erratic rainfall and increasing temperature to increasing threats to household water supply and the sustainability of their livelihoods overall. These authors also noted globalization as a driver of local vulnerability. Hence, in addition to the observed increase in the recorded measures of vulnerability, regional and global socio-economic stressors may have further local-level resource dynamic and vulnerability implications. In Tanzania and particularly



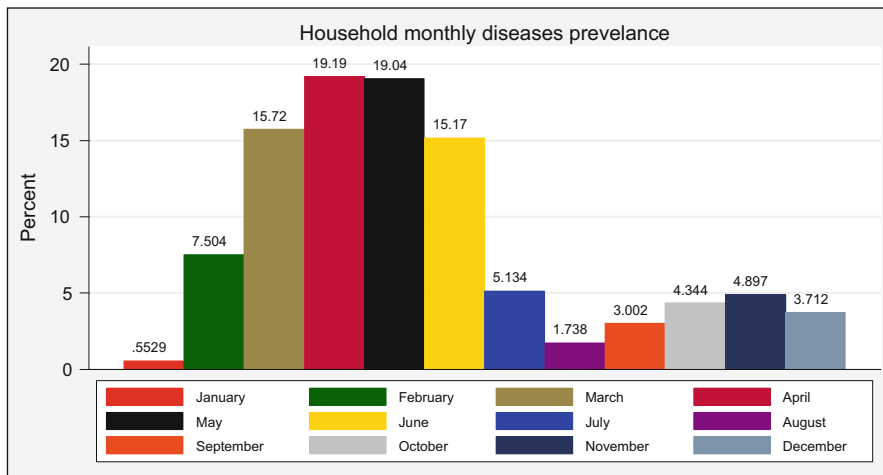
**Fig. 7** Monthly household water scarcity incidents (numbers above the bars indicate percentage frequency). (Source: Ndesanjo 2017)

Simanjiro District, large scale foreign direct investments have been associated with pastoralists disenfranchisement potentially exacerbating their vulnerability to prevailing socio-ecological stresses and shocks (Hodgson 2011).

The prevalence of diseases was used as another measure of climate change impacts. About 69% of households reported malaria the most prevalent disease. Diarrhea, malnutrition, and “magical-related” illnesses such as curses were mentioned by only 2% of surveyed households. The majority of households (82%) indicated that illness affected them for up to five months. Only a few households (9%) reported illness affecting them up to six of the previous twelve months. Illness incidents were concentrated between February and July (Fig. 8).

Malaria prevalence is largely influenced by climatic conditions such as temperature and humidity which determine the procreation of its vectors which are mosquitoes (Irish Aid 2018). This likely explains the high frequency of malaria cases in the months of the wet season. The Maasai are known for their knowledge of herbs for traditional medicine (Kiringe 2006; Sindiga 1994). Hence, the high number of malaria cases despite this knowledge may imply an increasing trend of diseases that were previously uncommon in semi-arid areas like Simanjiro District and against which traditional ecological knowledge holds no remedies (van Lieshout et al. 2004).

Approximately, 63% of households use modern treatments as their main disease control mechanism, whereas about 34% opt for traditional treatment. However, both options were reportedly used interchangeably. The use of traditional treatments may,



**Fig. 8** Monthly household disease prevalence (numbers above the bars indicate percentage frequency). (Source: Ndesanjo 2017)

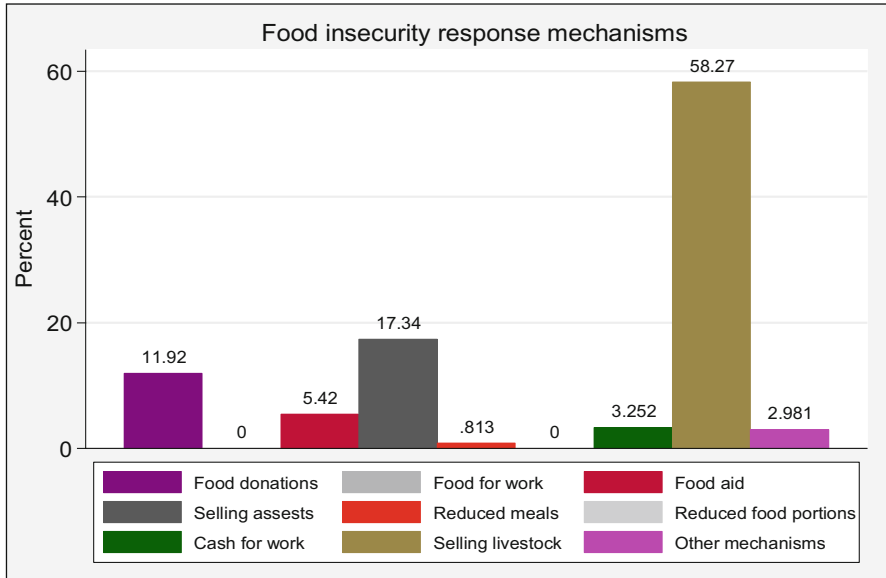
however, be under-reported here because mainly women seek this treatment including when children are ill and this may occur without the involvement of male household heads who were the respondents of this study. Modern treatments are likely to draw the attention of households' heads as this has financial implications that may require their consultation, whereas traditional medicine may be collected from the surrounding environment. Furthermore, traditional medicines are commonly used not only when a household member falls sick.

## Climate Change Adaptive Strategies

This section addresses adaptive strategies employed by pastoralists in the study area in response to increasing climate variability and directional climate change. The majority of households (98%) indicated that they had food security enhancement strategies in place in the previous twelve months. About 72% of the households indicated that food reserves were the food security strategy employed. Seed banking was another food security strategy reported used, albeit by fewer households (22%). This implies that most households take the food security question seriously and prepare for shocks.

Households were also asked about alternative mechanisms employed when common food security mechanisms (food reserve and seed banks) failed following shocks such as livestock mortality and crop failure. About 58% reported that they resort to selling livestock while the rest (17%) mentioned liquefying household assets in response to shocks (Fig. 9).

These findings suggest that households' ability to purchase food is the most important food security strategy. A study by Miller et al. (2014) found that when



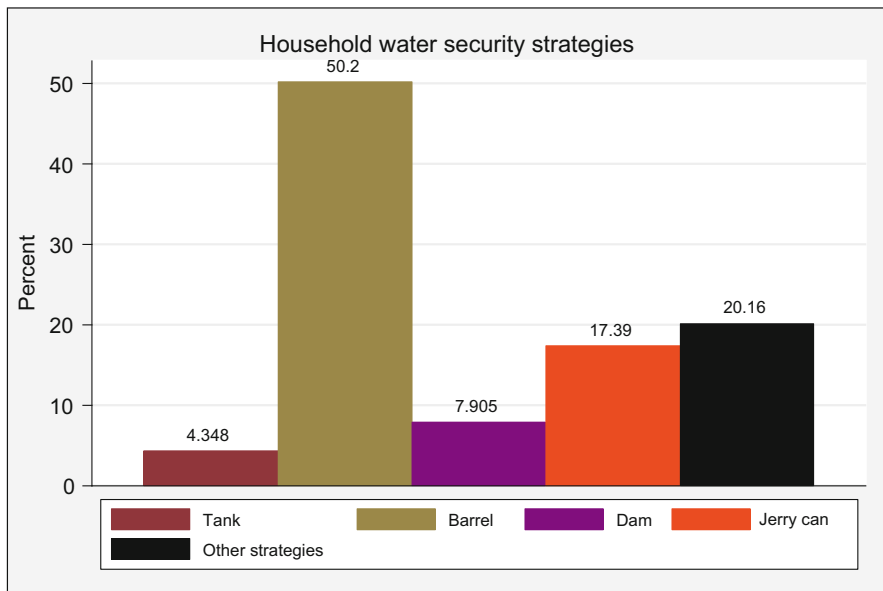
**Fig. 9** Household food insecurity response mechanisms (numbers above the bars indicate percentage frequency). (Source: Ndesanjo 2017)

the situation is critical, pastoral households even purchase pasture access rights and other livestock feeds in addition to food for household members. Hence, the affordability of purchased food is critical for households to stay afloat during periods with severe food scarcity. This means that a reliable income source and asset base is crucial for household response to climate shocks as well as to directional climate change. Other studies have shown that the motivation for selling livestock in most pastoral households is to raise money with which to buy food (Pauline et al. 2017; Silvestri et al. 2012; Suckall et al. 2014).

Responses on strategies used to maintain water security indicate that about 60% of households have a water storage mechanism in place. Other strategies used to ensure water security are presented in Fig. 10. Households were further asked about the strategies used when they encounter acute water shortage especially when their regular strategies to secure water prove futile. About 42% reported that they substantially reduce their water usage. Others (40%) reported that the most ideal option is migrating temporarily to areas where water is accessible.

The predominance of water storage may arise from the fact that the studied wards are not serviced by piped water thus leaving water-storing as the main option. This result resonates with findings by (Trærup and Mertz 2011) in Northern Tanzania who found the absence of piped water to be the main determinant of water storage mechanisms. More importantly, the prevalence of water storage as an adaptation strategy may arise from the semi-arid condition of Simanjiro District most of the year, otherwise forcing people to cover relatively long distances on foot in search of water (Smith et al. 2000).

As water scarcity intensifies, the most prudent response mechanism is to reduce water consumption (Miller et al. 2014). This means limiting water use to cooking



**Fig. 10** Household water security strategies (numbers above the bars indicate percentage frequency). (Source: Ndesanjo 2017)

and minimal washing only. People often have to compete for water among themselves as well as with livestock for water during the dry season and the price of water from private boreholes often increases due to the high demand. Noticeably, water allocation in times of scarcity tends to favour livestock over people. Consequently, only those with sufficient financial resources will have access to water. As a result households are compelled to reduce their water use. These results deviate from those of Miller et al. (2014) who associated water scarcity in Simanjiro District with the replacement of customary arrangements with local government water resources management arrangements.

Water scarcity is a common determinant of migration among pastoral communities (Berkhout 2012; Brockhaus et al. 2013). However, only a small segment of household members temporarily migrates with herds to other areas in search of water. The migration of an entire household was very common before the *Ujamaa* socialism program in Tanzania in the 1970s (Hodgson 2004). Implementation of the program saw massive resettlement and sedentarization across Maasailand in Tanzania, which has substantially altered the migration patterns of pastoral communities in northern Tanzania.

### Local Institutional Mechanisms and Climate Change Resilience

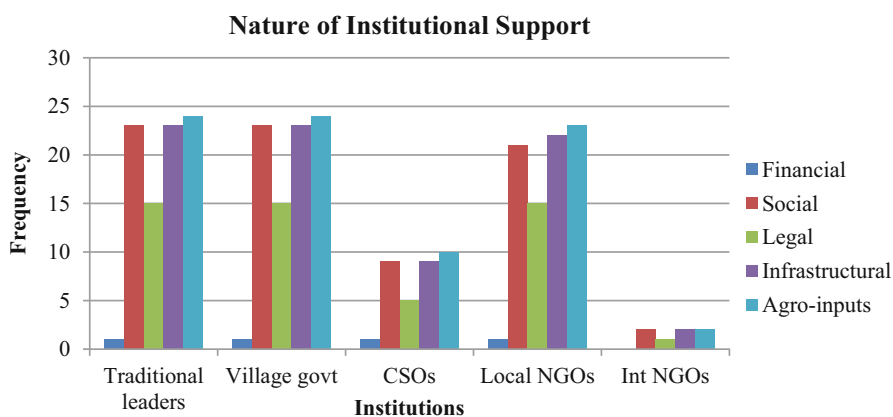
Information about the role of local institutional mechanisms in building climate change resilience was obtained from key informants ( $n = 24$ ). One of the questions

they were asked was to identify the nature of institutions that people approach for help in case of climatic shocks such as a drought. Based on responses, five categories of institutions were identified. All key informants interviewed ( $n = 24$ ) indicated that traditional leaders and the village government are the most common institutions approached for help. Local non-governmental organizations (NGOs) were another popular resort ( $n = 23$ ). Civil society organizations (CSOs) ( $n = 10$ ) and international NGOs ( $n = 2$ ) were also mentioned as institutions that people approach for help.

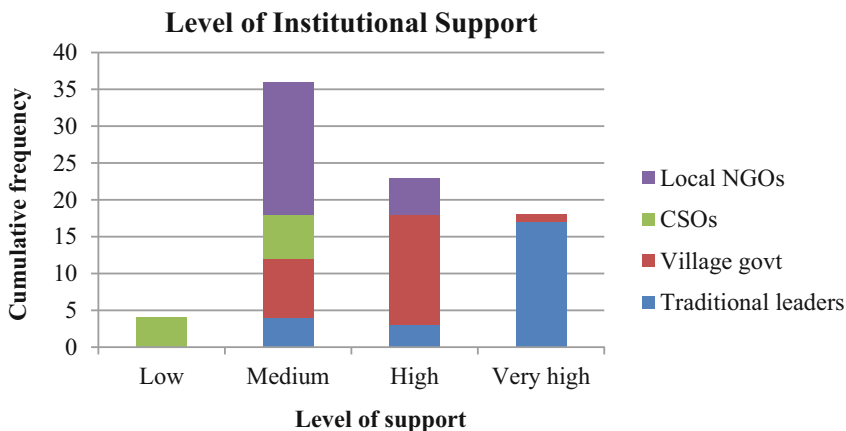
The predominance of traditional leaders and the village government may be explained by the social organization of Maasai societies and Tanzania's local government structure. Age is central for the social organization of Maasai society as duties and responsibilities are assigned according to age group (Ndagala 1991). Goldman and Riosmena (2013) describe that institutional frameworks among East African Maasai pastoralists are built on clan and age ties underpinned by decentralized leadership and traditional social networks. In the case of building resilience, local traditional leaders as the elders are in charge of resource control and allocation especially during periods of acute scarcity.

In Tanzania, the village council is the smallest local government unit overseeing day-to-day governance and development processes (Venugopal and Yilmaz 2010). This function makes the village government a must-go-to source for help whenever people encounter shocks that they are unable to handle. Similarly, interventions aimed at addressing local crises (including climate change) are channeled through village governments to people on the ground. Therefore, when people seek government support, the village government is the first place they would go. Thus, this institution is crucial in promoting local level resilience to climate and other socio-economic shocks.

Key informants identified several types of support provided by local institutions for building resilience (Fig. 11). Agricultural inputs form most of the support provided by traditional leadership ( $n = 24$ ), village government ( $n = 24$ ), and



**Fig. 11** Nature of support provided by local institutions. (Source: Ndesanjo 2017)



**Fig. 12** Institutional support ranking. (Source: Ndesanjo 2017)

local nongovernmental organizations ( $n = 23$ ). The same pattern was noted among civil society organizations ( $n = 10$ ) and international nongovernmental organizations ( $n = 2$ ). Other forms of support that were noted from the same institutions in order of their importance include infrastructural, social, legal, and financial support. Notably, unlike the rest of the institutions, financial support was not mentioned as provided by international nongovernmental organizations.

Institutional support in the form of agricultural inputs featured highest, possibly due to the dominant livelihood occupation, namely agro-pastoralism. This support was mainly in the form of extension services and disaster relief support when households succumb to shocks including mainly livestock mortality and crop failure due to drought. The role of local institutions in supporting local livelihoods and enhancing adaptability was noted in a study by Suckall et al. (2014) on community responses to climatic and socio-economic stresses in Zanzibar. The Zanzibar study found that local governments and cooperatives were instrumental in enhancing adaptive capacity not only through the provision of fishing and farming inputs but also providing market access assistance to local communities.

The level of support provided by institutions and their efficacy in promoting local resilience as ranked by key informants is presented in Fig. 12. Generally, most informants indicated that the level of support provided was medium. Traditional leaders were the highest-ranked local institution in terms of promoting local resilience followed by the village government. Local NGOs were ranked medium while civil society organizations were ranked lowest. Notably, international NGOs were not mentioned at all.

Traditional leaders affect the day-to-day life of pastoral communities particularly by leading people through extreme events such as drought. This explains the highly rated support of traditional leaders. The same applies to village governments. For example, findings by Miller et al. (2014) in Simanjiro-Tanzania indicate an increasing role of village committees in regulating resource use particularly water.

However, these results differ from observation by Berkhout (2012) who show that local government institutions are considered unable to support local communities' climate adaptation strategies. Noteworthy, civil society organizations and local NGOs were not rated favorably which may be explained by claims that most such organizations among Maasai pastoral communities are founded on the pretext of supporting local communities but in reality, serve personal interests of the founders (Hodgson 2011; Igoe 2003).

---

## Limitations

The study has limitations. It adopted a cross-sectional household survey approach and is thus subject to data reliability challenges in terms of the magnitude of income, crop harvests, livestock births and deaths, and climate impacts with the possibility of strategic answers. Nondisclosure tendency among respondents especially with livestock wealth was encountered in the study. This could have affected the validity of the information provided by respondents despite taking some remedial measures such as deploying *Maa* speakers as field enumerators as well as triangulating the information with local informants such as village leaders, extension officers, and elders. The study also relied on recalled information by respondents, which is not always accurate.

---

## Conclusions

This study sought to understand pathways to enhance the resilience of pastoral households in Simanjiro District-Northern Tanzania to increasing climate variability and directional climate change. A forty-year climatic trend analysis revealed changes in both temperature and precipitation in the study area. Also, extreme climatic events particularly droughts have become more common from the 1990s onwards. Drought is the main climate-induced shock to increasing household vulnerability in terms of food insecurity and water scarcity. Increasing prevalence of malaria during the wet season may also be attributed to climate variability and directional change and constitutes an increasing health risk to pastoral households. The main adaptive strategies employed by households include livestock and asset selling to address food needs and water storing accompanied by reduced usage. Local institutions and primarily traditional leaders and village governments were reported as fundamental in building local climate resilience.

The study concludes as follows. First, following observed climate trends in the study area, surveyed households are likely experiencing and responding more to local variability of the climate than permanent long-term shifts in the climate system. Second, country and regional level climate trends obscure local (district and village) level climate situations. Third, seasonal deterministic trends of food and water availability and/or scarcity as well as disease prevalence indicate the direct influence of local climate on household livelihoods. Fourth, diversifying livelihoods



from agro-pastoralism and migrating to areas better endowed with resources such as water are important pathways to climate resilience. Finally, due to social proximity and mutual understanding between local communities and their local (traditional) leaders, these (leaders) play a crucial role in promoting local level resilience building.

It is recommended that creating mechanisms to monitor the local climate and regularly inform local communities is crucial to enable them to adjust their activities accordingly. Such an exercise should reflect the local context in terms of information dissemination and uptake as well as local livelihoods and seasonality. Also, a gradual and medium to long-term livelihood diversification initiative is a highly recommended policy strategy to increase resilience among pastoral communities as opposed to the current policy which condemns pastoralism as a backward and environmentally destructive activity. Finally, future research on local climate resilience should focus on evaluating livelihood diversification scenarios and assess trajectories. Equally, local knowledge systems and institutions should buttress policy-making and implementation to promote local resilience.

**Acknowledgments** Funding for this research was provided by the Danish International Development Agency (DANIDA) through the Building Stronger Universities in Developing Countries (BSU) programme. The writing of this paper was supported by the Nordic Africa Institute (NAI), through the African Guest Researchers' Scholarship Programme.

---

## References

- Angelsen A, Larsen H, Olsen C (2012) Measuring livelihoods and environmental dependence: methods for research and fieldwork. Routledge, London. <https://doi.org/10.4324/9781849775694>
- Baird T (2014) Conservation and unscripted development: proximity to park associated with development and financial diversity. *Ecol Soc* 19(1):art4. <https://doi.org/10.5751/ES-06184-190104>
- Baird T, Leslie P (2013) Conservation as disturbance: upheaval and livelihood diversification near Tarangire National Park, Northern Tanzania. *Glob Environ Chang* 23(5):1131–1141. <https://doi.org/10.1016/j.gloenvcha.2013.05.002>
- Berkhout F (2012) Adaptation to climate change by organizations: adaptation to climate change by organizations. *Wiley Interdiscip Rev Clim Chang* 3(1):91–106. <https://doi.org/10.1002/wcc.154>
- Brockhaus M, Djoudi H, Locatelli B (2013) Envisioning the future and learning from the past: adapting to a changing environment in northern Mali. *Environ Sci Pol* 25:94–106. <https://doi.org/10.1016/j.envsci.2012.08.008>
- Chambers R, Conway G (1992) Sustainable rural livelihoods: practical concepts for the 21st century. IDS Discussion Paper 296. IDS, Brighton
- Godber O, Wall R (2014) Livestock and food security: vulnerability to population growth and climate change. *Glob Chang Biol* 20(10):3092–3102. <https://doi.org/10.1111/gcb.12589>
- Goldman M, Riosmena F (2013) Adaptive capacity in Tanzanian Maasailand: changing strategies to cope with drought in fragmented landscapes. *Glob Environ Chang* 23(3):588–597. <https://doi.org/10.1016/j.gloenvcha.2013.02.010>
- Hodgson D (2004) Once intrepid warriors: gender, ethnicity, and the cultural politics of Maasai development. Indiana University Press, Bloomington

- Hodgson D (2011) *Being Maasai, becoming indigenous: postcolonial politics in a neoliberal world*. Indiana University Press, Bloomington
- Homewood K (2004) Policy, environment and development in African rangelands. *Environ Sci Pol* 7(3):125–143. <https://doi.org/10.1016/j.envsci.2003.12.006>
- Homewood K, Kristjanson P, Trench P (eds) (2009) *Staying Maasai? Livelihoods, conservation, and development in East African rangelands*. Springer, New York
- Igoe J (2003) Scaling up civil society: donor money, NGOs and the pastoralist land rights movement in Tanzania. *Dev Chang* 34(5):863–885. <https://doi.org/10.1111/j.1467-7660.2003.00332.x>
- Irish Aid (2018) Tanzania country climate change risk assessment report. Resilience and Economic Inclusion Team, Policy Unit, Dar es Salaam
- Kangalawe R (2017) Climate change impacts on water resource management and community livelihoods in the southern highlands of Tanzania. *Clim Dev* 9(3):191–201
- Kiringe J (2006) A survey of traditional health remedies used by the Maasai of Southern Kaijiado District, Kenya. *Ethnobot Res Appl* 4:061–074
- Lynn S (2010) In: Fort Collins (ed) *The pastoral to agro-pastoral transition in Tanzania: human adaptation in an ecosystem context*. Graduate Degree Program in Ecology. Colorado State University. Retrieved from [http://economics-of-cc-in-tanzania.org/images/Stacy\\_Lynn\\_Pastoralism\\_TZ\\_Draft\\_2010\\_08-09\\_draft.pdf](http://economics-of-cc-in-tanzania.org/images/Stacy_Lynn_Pastoralism_TZ_Draft_2010_08-09_draft.pdf)
- McCabe J, Leslie P, DeLuca L (2010) Adopting cultivation to remain pastoralists: the diversification of Maasai livelihoods in Northern Tanzania. *Hum Ecol* 38(3):321–334. <https://doi.org/10.1007/s10745-010-9312-8>
- McKune S, Silva J (2013) Pastoralists under pressure: double exposure to economic and environmental change in Niger. *J Dev Stud* 49(12):1711–1727. <https://doi.org/10.1080/00220388.2013.822067>
- Mertz O, Mbow C, Reenberg A, Diouf A (2009) Farmers' perceptions of climate change and agricultural adaptation strategies in rural Sahel. *Environ Manag* 43(5):804–816. <https://doi.org/10.1007/s00267-008-9197-0>
- Miller B, Leslie P, McCabe J (2014) Coping with natural hazards in a conservation context: resource-use decisions of Maasai households during recent and historical droughts. *Hum Ecol* 42(5):753–768. <https://doi.org/10.1007/s10745-014-9683-3>
- Ndagala D (1991) *Pastoralism and rural development: the Ilparakuyo experience*. Reliance Publishing House, New Delhi
- Ndesanjo R (2017) *Pathways to enhance climate change resilience among pastoral households in Simanjiro District-Northern Tanzania*. Unpublished PhD thesis, University of Dar es Salaam, Dar es Salaam
- Orlove B (2019) Climate change and the quality of growth in Africa. In: Akbar N, Stiglitz JE, Kanbur R (eds) *The quality of growth in Africa*. Columbia University Press, New York, pp 325–349
- Paavola J (2008) Livelihoods, vulnerability and adaptation to climate change in Morogoro, Tanzania. *Environ Sci Pol* 11(7):642–654. <https://doi.org/10.1016/j.envsci.2008.06.002>
- Pardoe J, Conway D, Namaganda E, Vincent K, Dougill A, Kashaigili J (2018) Climate change and the water-energy-food nexus: insights from policy and practice in Tanzania. *Clim Pol* 18(7):863–877. <https://doi.org/10.1080/14693062.2017.1386082>
- Pauline N, Vogel C, Grab S, Liwenga E (2017) Smallholder farmers in the Great Ruaha River sub-Basin of Tanzania: coping or adapting to rainfall variability? *Clim Dev* 9(3):217–230. <https://doi.org/10.1080/17565529.2016.1184607>
- Pittiglio C, Skidmore A, van Gils H, Prins H (2012) Identifying transit corridors for elephant using a long time-series. *Int J Appl Earth Obs Geoinf* 14(1):61–72. <https://doi.org/10.1016/j.jag.2011.08.006>
- Reed M, Podesta G, Fazey I, Geeson N, Hessel R, Hubacek K, Thomas A (2013) Combining analytical frameworks to assess livelihood vulnerability to climate change and analyse adaptation options. *Ecol Econ* 94:66–77. <https://doi.org/10.1016/j.ecolecon.2013.07.007>

- Rodima-Taylor D (2012) Social innovation and climate adaptation: local collective action in diversifying Tanzania. *Appl Geogr* 33:128–134. <https://doi.org/10.1016/j.apgeog.2011.10.005>
- Sewando PT, Mutabazi KD, Mdoe NYS (2016) Vulnerability of agro-pastoral farmers to climate risks in northern and central Tanzania. *Dev Stud Res* 3(1):11–24
- Silvestri S, Bryan E, Ringler C, Herrero M, Okoba B (2012) Climate change perception and adaptation of agro-pastoral communities in Kenya. *Reg Environ Chang* 12(4):791–802. <https://doi.org/10.1007/s10113-012-0293-6>
- Sindiga I (1994) Indigenous (medical) knowledge of the Maasai. *Indig Knowl Dev Monit* 2(1):16–18
- Smith K, Barrett C, Box P (2000) Participatory risk mapping for targeting research and assistance: with an example from East African pastoralists. *World Dev* 28(11):1945–1959
- Suckall N, Tompkins E, Stringer L (2014) Identifying trade-offs between adaptation, mitigation and development in community responses to climate and socio-economic stresses: evidence from Zanzibar, Tanzania. *Appl Geogr* 46:111–121. <https://doi.org/10.1016/j.apgeog.2013.11.005>
- Suryabhagavan K (2017) GIS-based climate variability and drought characterization in Ethiopia over three decades. *Weather Clim Extrem* 15:11–23. <https://doi.org/10.1016/j.wace.2016.11.005>
- Trærup S, Mertz O (2011) Rainfall variability and household coping strategies in Northern Tanzania: a motivation for district-level strategies. *Reg Environ Chang* 11(3):471–481. <https://doi.org/10.1007/s10113-010-0156-y>
- van Lieshout M, Kovats R, Livermore M, Martens P (2004) Climate change and malaria: analysis of the SRES climate and socio-economic scenarios. *Glob Environ Chang* 14(1):87–99. <https://doi.org/10.1016/j.gloenvcha.2003.10.009>
- Venugopal V, Yilmaz S (2010) Decentralization in Tanzania: an assessment of local government discretion and accountability. *Public Adm Dev* 30(3):215–231
- Woodhouse E, McCabe J (2018) Well-being and conservation: diversity and change in visions of a good life among the Maasai of Northern Tanzania. *Ecol Soc* 23(1):43. <https://doi.org/10.5751/ES-09986-230143>

**Open Access** This chapter is licensed under the terms of the Creative Commons Attribution 4.0 International License (<http://creativecommons.org/licenses/by/4.0/>), which permits use, sharing, adaptation, distribution and reproduction in any medium or format, as long as you give appropriate credit to the original author(s) and the source, provide a link to the Creative Commons license and indicate if changes were made.

The images or other third party material in this chapter are included in the chapter's Creative Commons license, unless indicated otherwise in a credit line to the material. If material is not included in the chapter's Creative Commons license and your intended use is not permitted by statutory regulation or exceeds the permitted use, you will need to obtain permission directly from the copyright holder.





# Building Capacity to Cope with Climate Change-Induced Resource-Based Conflicts Among Grassroots Communities in Kenya

# 127

John Kibe Maguta, Daniel M. Nzengya, Chrocosiscus Mutisya, and Joyce Wairimu

## Contents

Introduction and Background .....	2613
Literature Review .....	2614
Theoretical Review .....	2614
Empirical Review .....	2615
Research Methodology .....	2616
A Map of the Study Site .....	2617
Brief Description of the Study Sites .....	2618
Data Collection .....	2619
Data Analysis .....	2619
Results and Discussions .....	2619
Sociodemographic Characteristics of the Sample .....	2619
Perceptions of Impacts on Climate Change on Livelihoods .....	2620
Citizens' Perceptions of the Prevalence of Climate Change Induced Resource-Based Conflicts .....	2622
Citizens' Perceptions of Contribution of Climate-Change to Resource-Based Conflicts ...	2625
Conclusion .....	2628
Suggestions for Further Research .....	2629
References .....	2629

This chapter was previously published non-open access with exclusive rights reserved by the Publisher. It has been changed retrospectively to open access under a CC BY 4.0 license and the copyright holder is "The Author(s)". For further details, please see the license information at the end of the chapter.

J. K. Maguta (✉)

Faculty of Social Science, St Paul's University, Limuru, Kenya

e-mail: [kibemaguta@gmail.com](mailto:kibemaguta@gmail.com)

D. M. Nzengya · C. Mutisya · J. Wairimu

Department of Social Sciences, St Paul's University, Limuru, Kenya

e-mail: [dnzengya@yahoo.com](mailto:dnzengya@yahoo.com); [chrocncjeru@gmail.com](mailto:chrocncjeru@gmail.com); [Joycemathenge9@gmail.com](mailto:Joycemathenge9@gmail.com)

© The Author(s) 2021

W. Leal Filho et al. (eds.), *African Handbook of Climate Change Adaptation*,  
[https://doi.org/10.1007/978-3-030-45106-6\\_131](https://doi.org/10.1007/978-3-030-45106-6_131)

2611

**Abstract**

Kenya is among the world's most vulnerable countries to climate change-related stresses and extreme events. According to FAO, over 75% of the country is classified as arid and semiarid with rainfall availability and amounts quite unevenly spread across the different parts of the country. The country has very skewed distribution of water sources with the western area being relatively well endowed with abundant water resources. The exponential growth in the country's population over the years, together with rapid environmental degradation and poor water resource development programs, have worsened the country's vulnerability to the effects of climate change. Ethnic conflicts over land resources are common-place in Kenya's rural areas where majority of the people live and the effects of extreme climate change events are likely to exacerbate resource-based conflicts. In this chapter we explore the extent of climate change-induced resource conflicts in three counties along rainfall availability gradient, namely, Kiambu County which experiences relatively high rainfall and also high urban population, Machakos County, which generally experiences modest rainfall availability, and Makueni County regarded to be one of the most arid and semiarid counties in the country. Data were collected in 2017 using a closed ended questionnaire. Between-subjects MANOVA design was used to examine relationship between independent and dependent variables. Qualitative results of the open-ended question reveal that climate change impacts can be diverse, particularly for vulnerable regions such as arid and semiarid regions such as Makueni County. In this county, respondents mentioned nine ways climate change had impacted communities, with the most frequently mentioned impact being increasing food insecurity followed by increasing water shortages. Machakos followed with seven impacts mentioned starting with increased water shortages followed by scarcity of pasture. In Kiambu County, only four impacts were mentioned with food insecurity being frequently mentioned among the list of impacts of climate change in the county. Results of the descriptive and inferential statistics reveal that resource-based conflicts vary along the hydrological gradient. In Machakos County, resource-based conflicts are perceived to have risen during the last 5 years ( $M = 3.92$ ,  $SD = 0.66$ ), followed by Makueni ( $M = 4.10$ ,  $SD = 0.670$ ). Kiambu residents do not consider resource-based conflicts to have risen during the last 5 year, ( $M = 2.50$ ,  $SD = 1.38$ ). Differences in severity of climate related conflicts are statistically significant,  $F_{2, 76} = 12.78$ ,  $p < 0.01$ . Also, climate change is strongly perceived to be a factor in the rise of resource-based conflicts in Machakos County ( $M = 4.10$ ,  $SD = 0.67$ ). In Makueni County as well, climate change is perceived to be a significant contributor to resource-based conflicts ( $M = 3.98$ ,  $SD = 1.70$ ). These findings have relevance on county and national policies targeted to build capacity to cope with climate change induced resource-based conflicts among grassroot communities in Kenya.

**Keywords**

Climate change induced resource-based conflicts · Grassroot communities · Women · Adaptation projects · Kenya

## Introduction and Background

Global climate change is one of the major socioeconomic and environmental challenges facing communities in the twenty-first century. The impacts of climate variability including extreme climate events are many, complex, and wide-ranging, and include among other human conflicts. In the African continent, the impacts of global climate change are exacerbated by environmental degradation, political instability, poor governance and corruption, rapid population growth, and urbanization, largely in form of informal settlements. Impacts on the agricultural sector, especially impacts on export crops such as coffee are feared to affect the economic production and growth in different regions. Reduction in acreage under cash crops has meant low income. For the last few decades, climate change has affected many regions of the world. According to Hussein et al. (1999), climate change exacerbates conflicts. The authors have argued here that human activities coupled with droughts of the 1970s and 1980s caused a lot of tensions in Africa. Communities got into conflict with each other as they competed over diminishing resources. This view gets support from Benjaminsen and Ba (2009). According to the duo, the conflicts between farmers and herders in the Niger Delta of Mali were escalated by the droughts mentioned. Herders grazed into the grain fields of cultivators leading to conflicts that at times became violent. Such conflicts are thought to have undermined the loyalty to the government. Governments have been accused of favoring one party at the expense of the other. In the case of Mali, the government was accused of favoring farmers and it was not taken kindly by herders. This resulted to frequent conflicts leading to stagnation in development. Peters and Mayhew (2019) have mentioned the increasing conflicts in Africa and the Arabic states while Price (2019) has given details of worrying trends in Afghanistan all coming from climate change conflicts. It is evident that climate change has scared the world with the scare being more real as years pass by.

In sub-Saharan Africa, climate variability threatens to reverse the decades of government investments to eradicate extreme poverty. Africa faces some of the worst forms of conflicts, and it is feared that climate change will further confound governments' investments for peaceful coexistence amongst communities and nations. While majority of the sub-Saharan African nations failed to achieve the Millennium Development Goals, it is feared that climate variability potentially poses a significant threat to the region's efforts to achieve the Sustainable Development Goals (SDGs). Most countries in SSA rely on rain-fed agriculture for livelihoods and incomes, thus extreme events such as the increasing and more prevalent and prolonged droughts with the continent's limited surface water resources complicates achieving some of the SDGs such as ending poverty in all its forms, ending hunger and achieving food security as well as ensuring healthy lives and economic growth among others. Sub-Saharan Africa has incidentally the most rapidly growing urban population posing real threat to water available for food production and other economic activities. In the huge arid and semiarid areas of SSA that are predominantly the home of pastoral communities, growing scarcity of pasture and water for livestock is likely to remain a huge driver of conflicts. Limited investments on

technology and weak institutions and governance further comprise sources of vulnerability to Africa's development sectors which include climate change.

Kenya is among the world's most vulnerable countries to climate change-related stresses and extreme events. Seventy-five percent of Kenya's land mass is classified as arid and semiarid with rainfall availability and amounts quite unevenly spread across the different parts of the country. The country's western region is relatively well endowed with abundant water resources. The exponential growth in the country's population over the years, together with rapid environmental degradation and poor water resource development programs, have worsened the country's vulnerability to the effects of climate change. Ethnic conflicts over land resources are common-place in Kenya's rural areas where majority of the people live and the effects of extreme climate change events are likely to exacerbate resource-based conflicts. In this chapter we explore the extent of climate change-induced resource conflicts in three counties along rainfall availability gradient, namely, Kiambu County which experiences relatively high rainfall and also high urban population, Machakos County, which generally experiences modest rainfall availability, and Makueni County regarded to be one of the most arid and semiarid counties in the country.

---

## Literature Review

### Theoretical Review

This chapter draws on Strain Theory which posits that achievements of individuals and communities is pegged on goals and aspirations in life, and whenever these goals and aspirations are threatened, conflicts are bound to take place. The extreme climatic changes taking place in the world are threatening the ability to achieve the desires of different individuals and the society at large leading to tensions and conflicts. According to Agnew (2012), inability to achieve different objectives and goals lead to change in behavior. When climate changes occur, the economic status of people gets affected negatively. Increasing desertification has led to diminishing fodder for animals as well as lower production on the part of cultivators. The conflicts witnessed between farmers and herders in Tanzania attest to this. According to Benjaminsen et al. (2009), the conflicts whose source was climatic changes left a lasting mark. Enmity and killings resulted. The approach taken by Strain Theory is Malthusian. As the amount and quality of resources decline, competition between individuals as well as groups increases. Meierding (2013) contends that competition over resources result to violent clashes. In the African region, competition over pasture and water has been the main source of conflicts. Increasing desertification has also contributed to these conflicts. As cited elsewhere in this work, the conflicts have resulted to dire consequences including the loss of lives.

The Relative Deprivation Theory developed by Samuel Stouffer during World War II purports that people take action to acquire something that others possess and which they believe they too should have. According to Stouffer, opportunities, status, and desire for material gain at times lead to use of force. When resources become diminished or of lower quality, those who miss out feel disadvantaged in comparison to others. Those that are relatively deprived feel anger especially when they feel the privileged are not willing to share. Sunga (2014) contends that climate change creates conditions that make ethnic groups struggle for scarce resources. The author argues that those who fail to get the scarce resources are motivated to use violence which ends up in serious atrocities. The author views extreme climate change as a risk factor and a major cause of ethnic violence engulfing the developing countries. This argument raises serious concerns and calls for attention to the changing climate conditions across the world.

The Social Disorganization Theory has been used to explain the security implications of climate change. Due to climate change, communities have been on the move looking for less hostile weather to cultivate and herd animals. This has led to push and pull not only between man and man but also between man and wildlife. Communities become disorientated by climate change and this affects development. The energy and time that would have been devoted to economic progress is lost to look for better living conditions. Social cohesion and integration become compromised. Elsewhere in the African region, climate change has led to drought, landslides, desertification, pollution, sand storms, disease, hunger, and unusual weather (Folami and Folami 2013). In Northern Kenya, desertification has escalated with increase in sandstorms. Getting forage has become a hard task with conflicts over water increasing. The conflicts have at times led to deaths and fear. It is not uncommon for communities to attack their neighbors in the name of restocking when animals have been wiped out by drought.

## **Empirical Review**

Climate change is arguably one of most serious environmental problems facing humans in the twenty-first century. The consequences of increasingly variable climate and extreme climate events are many and complex, among them resource-based conflicts. Climate-related resource-based conflicts are extremely varied from local, regional, to global contexts. Climate variability may directly and indirectly trigger diverse conflicts. Conflicts may be triggered for instance when communities migrate as a response to cope with impacts to different areas where they exert increased competition for resources in their new destinations. The impacts of climate change are particularly more profound in communities where people rely on their immediate environment for basic needs. In Nigeria, for instance, Folami and Folami (2013) have noted that climate change has resulted into extreme droughts triggering severe water scarcity.



Although impacts of extreme climate change events are felt most in the developing nations, developed nations too experience challenges of climate variability. In the United States, damages from tornadoes, floods, droughts, hurricanes, and wildfires during 2011 caused more than \$200 billion in losses and over 1,000 deaths. Tornadoes, floods, droughts, hurricanes, and wildfires were all attributed to climate change (Scott and Andrade 2012). In South Africa, it is feared that grain production is likely to reduce due to climate change. According to Kuhlmann et al. (2012), climate change has had disastrous effects on pollination of flowering plants. Bees have been noted to shift to the more suitable areas to survive. In the same line, climate change has lowered grain production leading to starvation for the people. The increase of starvation, hunger, and want is a trigger for conflicts.

The past 10 years have witnessed conflict with nature resulting from improved technology and the fact that man is demanding more from nature. In developing countries, conflicts with wildlife have increased. Elsewhere, improved technology has enabled the powerful to clear large areas of land and exploit the natural resources at an alarming rate. Since climate change does not limit itself to a geographic region, the effects of change are felt far and wide. In sub-Saharan Africa, many communities live in economically poor and marginal regions. They therefore experience shortage of water and pasture the greater part of the year. Arable land is scarce (Serdeczny et al. 2017; Hadush 2018).

In Northern Kenya and upper Eastern region of the country, most people depend on those scarce resources for survival. Since rainfall determines the availability of water, pasture, milk, crop yields, and so on, its failure causes a lot of stress. Resources that people depend on get scarcer. Drying of shallow wells and earth dams lead to pressure that more often than not culminates into full blown fighting. Witsenburg and Adano (2009) have noted that in Marsabit region, conflicts over water and pastures have become a common phenomenon particularly during dry spells. Also, the authors have noted a rising competition between livestock and wildlife over pasture and water.

---

## Research Methodology

The study used a cross-sectional survey design to collect and analyze data. Survey method has several benefits; it allows rapid collection, analysis, and reporting of research findings over relatively short period of time. Longitudinal design may, however, be needed to allow observations of conflict related to resources use over time and the mechanism driving the conflicts.

## A Map of the Study Site



## Brief Description of the Study Sites

### Kiambu County

Kiambu County has warm weather with the warmest month being 18.7 °C and the coolest month registering 12 °C. The hottest months are January–March and September–October, while the coolest months are June and July. The rainfall aggregate for the county is 1000 mm annually. This is quite conducive for agriculture activities. Kiambu covers an area of 2,543.2 km<sup>2</sup>. It has a population of 2,417,735 people according to Kenya National Bureau of Statistics (GoK 2019). The population density is 658.14 people per km<sup>2</sup>. The population is predominantly Kikuyu community who comprise the most populous tribe in Kenya. Other ethnicities include Asian and Caucasian population working as businessmen or for various foreign missions. The county is cosmopolitan and hosts other communities such as Luhya, Luo, Maasai, Kamba, Meru, and Kalenjins, among others. The poverty index for the County is 21.3. The County relies mainly on agriculture and industries to sustain its economy.

### Machakos County

Machakos County stretches from latitudes 0° 45' south to 1° 31' South and longitudes 36° 45' east to 37° 45' east. It is mainly semiarid with temperatures between 18 °C and 29 °C, July being the coldest month while October and March are the warmest. The average rainfall is between 500 mm and 1300 mm. The short rains are expected in October and December while the long rains are expected in March to May. Machakos County suffers from periodic drought between February–March and August–September. The County covers an area of 6208.2 km<sup>2</sup> and has an estimated population of 1,421,932 (GoK 2019). The population density is 240 persons per km<sup>2</sup> -and the poverty index is 59.6%. Kambas are the predominant tribe of Machakos County although other tribes live and work in the county. The county practices subsistence farming of maize and drought-resistant crops such as sorghum, millet fruits, and vegetables.

### Makueni County

Makueni County is located within the former Eastern Province just like her neighbor Machakos. It lies between latitude 1° 35' and 3° 00' south and longitude 37° 10' and 38° 30' east. It is populated mainly by the Kamba community although many other communities live and work there. The County occupies 8,034.7 km<sup>2</sup> with a population of 987,653 people GoK (2019). Of the three counties under the study, it is more sparsely populated with population density of 120.9 per km<sup>2</sup>, though still slightly higher than the national average. The climate of the County is generally dry. The county receives low inadequate rainfall of 600 mm with the average temperature being 23 °C to sustain any meaningful agriculture. The residents hence experience constant crop failures and are consequently in the list of counties in need of support of relief food. To sustain their livelihood, the residents harvest sand, degrading the few seasonal water sources existing. Makueni suffers from a poor road network in contrast to the other two counties under study.

## Data Collection

Data was collected using closed ended questionnaires. There were eight Likert scale type of statements and participants were required to rank their responses, each statement on a scale of 1 = somewhat becoming less prevalent to 5 = becoming more prevalent. The sampler statement is “*conflicts related to scarcity of firewood, such as people illegally collecting/harvesting firewood in neighbors farms, quarrelling over collection of firewood*”. Variable two measured participants’ ranking to climate change as contributor to a list of similar statements related to conflicts to resource use according to scale 1 = does not contribute at all to 5 = contributes a lot. Additional sociodemographic data collected included gender of the respondent, education attainment, and age category. A total of 85 participants completed the questionnaires, comprising 30 from Makueni, 30 from Machakos, and 25 from Kiambu counties, respectively.

## Data Analysis

Data was analyzed using cross-tabulation to compare percent frequency distribution by county. In addition, a one-way multivariate analysis of variance (MANOVA) between-subjects design was used to investigate the relationship between dependent variables and the independent variables, region, and gender.

## Results and Discussions

### Sociodemographic Characteristics of the Sample

Results of the sociodemographic characteristics of the sample are summarized in Table 1.

**Table 1** Sociodemographic characteristics of the sample

Variable	Categories	Makueni (%)	Machakos (%)	Kiambu (%)
<b>Age</b>	18–29	30	33.3	4.2
	30–39	26.7	23.3	33.3
	40–59	40.0	43.3	41.7
	60 years or older	3.3	0.0	20.8
<b>Education attainment</b>	<b>Certificate</b>	3.3	36.7	91.7
	Diploma	23.3	30.0	8.3
	Postgraduate diploma	16.7	6.7	0.0
	Bachelor’s degree	40.0	23.3	0.0
	Postgraduate degree (Master or PhD)	16.7	3.3	0.0

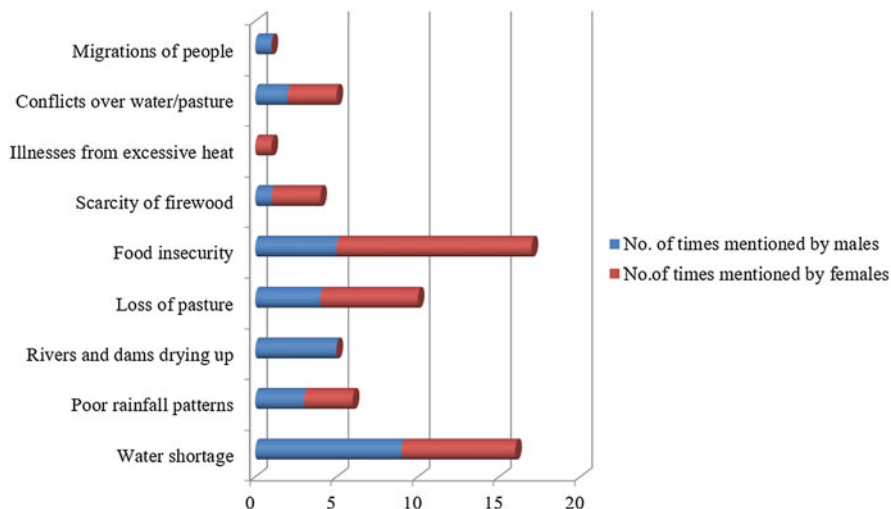
The frequency distribution in Table 1 shows that majority of respondent were in the category of age 40–59 years. Machakos had 40%, Makueni 43.3%, and Kiambu 41.7% in this category. Although the age bracket in this category was widespread in comparison to other categories, this category of respondents is made up of adults who have lived for a long time to experience changes brought about by climate change. Unlike those above 60 years who might suffer memory lapse, the 40–59 years group availed information which is quite vital. The 40–59 years category group has lived long enough to experience the changing climate patterns and conflicts over resources. It is surprising that while Kiambu had 20.8% of respondents being over 60 years, Makueni had only 3.3%, while Machakos had none. The lowest category in age had large numbers for Makueni (30%) and Machakos (33.3%), while Kiambu had only 4.2%.

The implication here is that climate change hardships might have lowered life expectancy in Makueni and Machakos. The higher percentage of those over 60 years in Kiambu is probably attributable to less climate change-related conflicts leading to longer life as a result of reduced stress. Alternatively, due to higher levels of development and probably having a more informed community, Kiambu County could be having people who are practicing more family planning hence a lower percentage of the young (age 18–29).

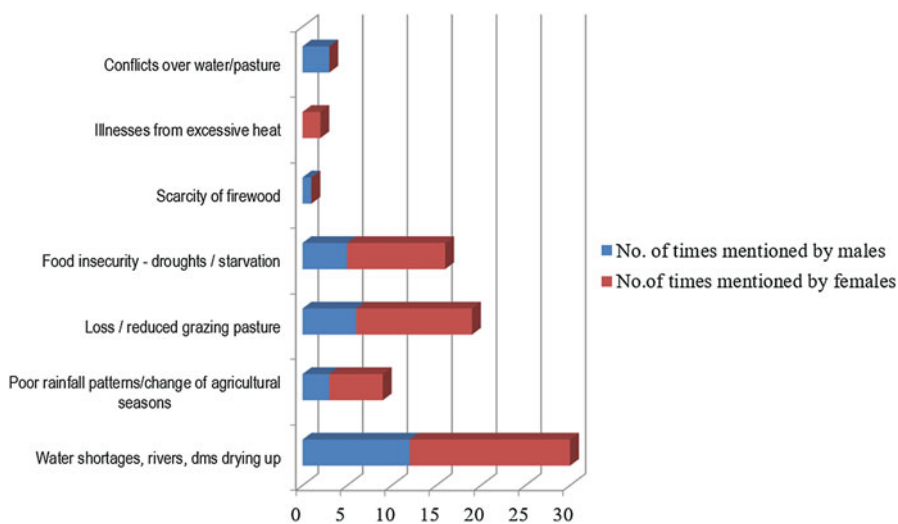
The findings in education achievement among respondents were quite amazing. It was surprising that the bulk of respondents in Kiambu had their highest education achievement being a certificate (91.7%) and diploma (8.3%). Makueni and Machakos which are not as highly developed had respondents with higher education and of degree and above at 56.7% and 26.3%, respectively. This is probably an indicator that due to conducive climate in Kiambu, people are actively involved in production in agriculture and industry and therefore do not pursue higher education despite having very good educational facilities as compared to its counter-parts. Probably in Makueni and Machakos, unreliable rainfall forced the community to seek high level of education in order to stand a better chance of employment to earn a living. The implication here is that climate change conflicts in both Makueni and Machakos have some positive contribution.

## **Perceptions of Impacts on Climate Change on Livelihoods**

Respondents were asked what they perceived to be the impacts of climate change on peoples' livelihoods. Results are summarized in Figs. 1, 2, and 3. Climate change has had varied negative impacts on people's livelihoods with the more serious ones being water shortage and food insecurity though Kiambu County appears not affected by water shortage. The number of women affected by the adverse effects of climate is more than that of men probably because men venture into other income earning activities. It is possible that because of the arid nature of Makueni and Machakos, women feel the pinch more as they are the ones who must trek long distances looking for water and searching for food. While it is only five males who mentioned food insecurity in Makueni, the number of females is worrying as it

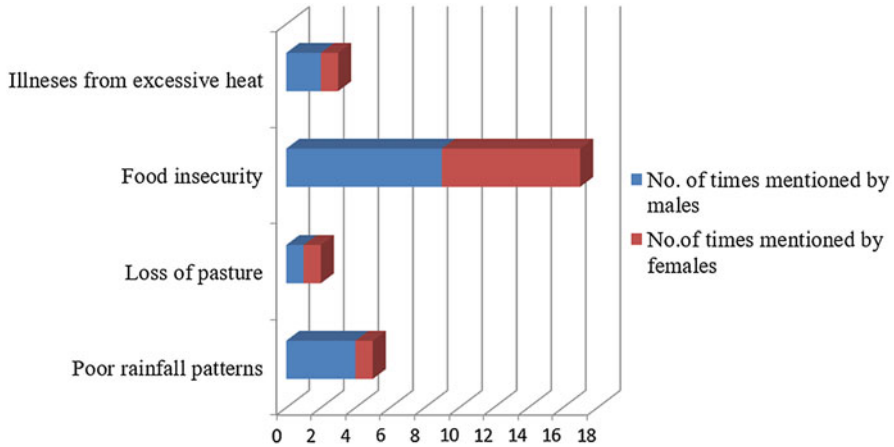


**Fig. 1** Frequently mentioned impacts of climate change on livelihoods in Makeni County



**Fig. 2** Frequently mentioned impacts of climate change on livelihoods in Machakos County

stands at ten which is double that of men. In Machakos, it is surprising that while only three males mentioned that food security emanates from climate change, ten females which are more than triple the number had a similar feeling. The case of Kiambu County is different with nine males and eight females sharing a similar view. While women shoulder almost the entire burden of feeding the family in the arid counties of Makeni and Machakos with men leaving for urban centers to look for green pastures, feeding the family appears a shared burden in Kiambu.



**Fig. 3** Frequently mentioned impacts of climate change on livelihoods in Kiambu County

On water shortage, Makueni and Machakos feel the adverse effects of climate change. While nine males and seven females have lamented on water shortage in Makueni, a similar trend is seen in Machakos where 8 men mentioned water scarcity with the number of females almost doubling at 15. For the case of Machakos, it is surprising that more men than women lamented on water shortage. It is worth researching more on this area to establish why males would feel the pinch of water scarcity more than women. For the men reporting water shortage, it is possible that water vending is an income generating activity due to the biting water shortage in the semiarid zone. In Machakos, Kamba women and children are responsible for livestock feeding and fetching water.

Probably because of being in the highlands, Kiambu does not appear affected by water shortage. For Kiambu, having embraced the technology of water harvesting and having embraced water piping, there was no respondent who mentioned water shortage.

Wilting of plants and pasture is also felt more in Makueni and Machakos with the number of men and women being 4:6 and 6:13, respectively. In Kiambu, the numbers are a paltry 1:1.

Water shortage is an issue of major concern in Makueni and Machakos counties that needs quick response. Unless climate change is addressed quickly, lives will continue being threatened. It is surprising that even an area like Kiambu which is in the highlands has started experiencing food shortages occasioned by changing rain patterns due to climate change.

### **Citizens Perceptions of the Prevalence of Climate Change Induced Resource-Based Conflicts**

Next was a Likert scale type of questions in which respondents were asked to rank prevalence of resource-based conflicts in the counties during the last 5 years.

There were eight Likert scale type of statements and participants were required to rank their responses each on a scale of 1 = somewhat becoming less prevalent to 5 = becoming more prevalent. The sampler statement is “*conflicts related to scarcity of firewood, such as people illegally collecting/harvesting firewood in neighbors farms, quarrelling over collection of firewood*”. Respondents’ responses are summarized in Table 2. Conflicts related to people illegally watering their animals in other people’s water points were perceived to be becoming somewhat prevalent or more and more prevalent in Machakos at 73.4% while Kiambu had only 28% sharing this perception. Majority in Kiambu (68% of respondents) perceived that conflicts related to a person watering their animals in someone else’s water point were becoming either less or somewhat less. It is also quite striking that conflicts related to scarcity of grazing pastures are quite high in Machakos and Makueni while Kiambu reflects a very different picture. The reason for this conflict could be that the community practices both types of farming. Arable farming covers the largest part leaving a small portion for herding/grazing, unlike Kiambu residents who use zero grazing. The kind of livestock farming is an indicator of increased conflict due to scarce grazing resources. These findings are consistent with those of other researchers (Ifejika Speranza 2010). Conflicts over resources such as grazing fields and food have been reported. Over 73% of respondents in both Makueni (73.3%) and Machakos (80%) perceived conflicts related to scarcity of grazing pastures becoming somewhat prevalent or more and more prevalent in comparison to Kiambu which had only 36% perceiving the same. While 40% of respondents in Kiambu perceived that conflicts related to scarcity of grazing pastures were becoming less and less, none of the respondents of either Makueni or Kiambu felt the same. It was also striking that while 66.7% of respondents in Kiambu felt that conflicts related to people illegally harvesting grazing materials were becoming less and less frequent or somewhat less frequent, only 6.6% of those in Machakos felt the same. Makueni posted 29.9% with similar feeling. Conflicts related to scarcity for food had even more interesting results. While none of respondents in Machakos perceived this becoming less and less, almost half of those in Kiambu (48%) perceived such conflicts becoming less and less prevalent. On the other hand, conflicts related to building materials were perceived to become less and less prevalent in both Makueni (30%) and Kiambu (40%) unlike Machakos 6.7%. Conflicts related to sand harvesting also appear to be quite interesting. While well over 80% of respondents in Makueni (80%) and Machakos (83.4%) perceived that conflicts related to sand harvesting were on the increase, only, 22.7% of respondents in Kiambu had a similar perception.

The probable reasons for these patterns could be the level of development of the different counties. Kiambu has posted different findings with both Makueni and Machakos probably because Kiambu is more developed. The infrastructure in Kiambu is more developed. With the good road network, transporting goods to the market is quite fast in comparison to Makueni and Machakos. Kiambu is also more cosmopolitan than both Makueni and Machakos. Although the population is predominantly Kikuyu, Kiambu is cosmopolitan and hosts other communities such as Luhya, Luo, Maasai, Kamba, Meru, and Kalenjins among others. Such people bring in new skills and enhance the growth of Kiambu. Other ethnicities include Asians and Caucasian population who are good businessmen. All these plus the fact that



**Table 2** Citizens perceptions of the prevalence of resource-based conflicts

County	Becoming less and less prevalent <b>1 (%)</b>	Somewhat becoming less prevalent <b>2 (%)</b>	Unsure <b>3 (%)</b>	Somewhat becoming prevalent <b>4 (%)</b>	Becoming more prevalent <b>5 (%)</b>
<b>A) Conflicts related to scarcity of firewood, such as people illegally collecting/harvesting firewood in neighbors' farms, quarrelling over collection of firewood</b>					
Makueni	13.3	13.3	3.3	26.7	43.3
Machakos	0	3.3	6.3	26.7	63.3
Kiambu	28	24	8	20	20
<b>B) Conflicts related to scarcity of water, such as fights over water at water collection points, quarrelling over water queues</b>					
Makueni	13.3	3.3	3.3	30.3	50
Machakos	0.0	13.3	6.7	33.3	46.7
Kiambu	44.0	28.0	4.0	4.0	20.0
<b>C) Conflicts related to scarcity of water for livestock, such as people illegally watering their livestock in someone's water point</b>					
Makueni	23.3	20.0	6.7	16.7	33.3
Machakos	3.3	10.0	13.3	26.7	46.7
Kiambu	52.0	16.0	4.0	0.0	28.0
<b>D) Conflicts related to scarcity of grazing pastures, such as animals straying into neighbors' farms/ plots in search for grazing pasture</b>					
Makueni	0.0	26.7	0.0	30.0	43.3
Machakos	0.0	10.0	10.0	30.0	50.0
Kiambu	40.0	20.0	4.0	24.0	12.0
<b>E) Conflicts related to scarcity of grazing pastures, such as people illegally harvesting grazing materials in a neighbor's land/pasture</b>					
Makueni	13.3	16.6	10.0	16.7	43.3
Machakos	3.3	3.3	16.7	33.3	43.3
Kiambu	41.7	25.0	4.2	16.7	12.5
<b>F) Conflicts related to scarcity for food, such as neighbors and other people illegally harvesting food resources in a neighbor's farm</b>					
Makueni	16.7	26.7	0.0	26.7	30.0
Machakos	0.0	16.7	20.0	43.3	20.0
Kiambu	48.0	20.0	4.0	12.0	16.0
<b>G) Conflicts related to scarcity of building materials, such as people illegally harvesting thatch grass or building wood in a neighbor's farm</b>					
Makueni	30.0	6.7	10.0	33.3	20.0
Machakos	6.7	40.0	16.7	20.0	16.7
Kiambu	40.0	24.0	4.0	12.0	20.0
<b>H) Conflicts over sand harvesting</b>					
Makueni	6.7	13.3	0.0	23.3	56.7
Machakos	10.0	6.7	0.0	46.7	36.7
Kiambu	59.1	4.5	13.6	0.0	22.7

Kiambu is a host to various foreign missions has ensured a higher income and better living standards. Another probable reason why findings for Kiambu differ significantly with those of Makueni and Machakos is climate. While Kiambu receives an aggregate rainfall of 1000 mm annually, both Makueni and Machakos receive less than 700 mm with Makueni receiving only 600 mm which is not adequate for a variety of crops. While Kiambu relies on major cash crops like tea and coffee and a variety of food-crops, Makueni and Machakos at times fail to harvest any food. Makueni is classified among the arid regions of Kenya.

The standard of living is higher in Kiambu as compared to Makueni and Machakos. While the poverty index is 21.75% in Kiambu, Makueni is ranked at 64.1%. People in Kiambu are relatively well off with many relying on other sources of energy other than firewood. The reliable rainfall and higher living standards might also have led to individuals having their private sources of pasture and water for their animals. Again, unlike the people of Makueni and Machakos who rely on sand harvesting and charcoal burning as a source of employment, Kiambu residents are busy in the farms, industries, or working in Nairobi which is their next-door neighbor. On the other hand, the poverty index in Ukambani indicates increase household firewood conflict and more climate effects as a result of cleared indigenous trees for charcoal burning to earn a living.

The potential implications of the above are that the simmering conflicts might soon result into full-blown conflict. With well over 80% of respondents in both Makueni and Machakos perceiving that climate-related conflicts are somewhat becoming prevalent and/or becoming more and more prevalent, an alarm is starting to ring. If climate does not improve and no interventions are put in place, signs of the region emulating war-torn countries like Sudan can be predicted.

Unlike in Makueni where major policies have been passed targeting mitigating climate change, the County government of Kiambu has bills and policies concerned with improved production. Kiambu being a major agricultural and livestock production area, a bill on Abattoirs has been passed. In April 2014, the Agricultural Department Strategic Plan was launched. Some drafts on Animal Disease Bill and Veterinary services are under discussion. Revolving funds have been set aside to improve agriculture. Machakos on its part has been seeking for partnerships and investors to help develop the County and save it from climate-induced problems. Watson and Hussein Kochore (2012) while referring to the drought situation in Northern Kenya have recommended that scholars of climate change must act with speed. In a similar vein, the situation in Makueni and Machakos requires urgent attention. These research findings corroborate Watson and Hussein Kochore (2012) findings expressed in their study of Northern Kenya where the authors reported prevalence of climate change related conflicts.

### **Citizens' Perceptions of Contribution of Climate-Change to Resource-Based Conflicts**

Next was a Likert scale type of questions in which respondents were asked to rank climate change contribution to resource-based conflicts. Results are summarized in

Table 3. While an overwhelming 88% of Kiambu respondents perceived that climate change does not contribute a lot to conflicts related to firewood collection, a higher proportion in both Machakos and Makueni Counties shared a different opinion. Similar findings were witnessed in conflicts over water and grazing fields. While Kiambu saw almost no connection or too little between climate change and increased conflicts, with a 92%, Makueni and Kiambu were in sharp contrast with 6.7% and 33%, respectively. The figures for grazing pastures stood at 96% for Kiambu, 16.7% for Makueni, and only 10% for Machakos. The same figures were posted for illegal harvesting of grazing materials except for Machakos which had nil results. The feeling of Machakos was that there was a very strong correlation between climate change and grazing pastures related conflicts. An overwhelming 90% of those in Machakos said conflicts related to scarcity of grazing pastures were either somewhat increasing or were becoming more and more prevalent. In Makueni (70%) and Machakos (70%), there was a major perception that climate change is contributing to illegal harvesting of food in other people's farms. Only 4.3% of respondents in Kiambu felt the same with majority in Kiambu (95.6%) perceiving that climate change was either contributing nothing or too little to conflicts related to scarcity of food. Respondents in Kiambu saw almost no relation or a very slight relation between climate change and conflicts relating to building materials. The figure for Kiambu in this was 92%, while only 40% and 36.7% of Makueni and Kiambu, respectively, perceived the same. While each of Makueni and Machakos had more than 20% of respondents saying climate change was contributing more and more in conflicts related to building materials, Kiambu posted a nil result in that line. Perhaps more surprising are the findings from conflicts over sand harvesting. While Kiambu respondents (96%) perceived no or very slight connection between climate change and conflicts over sand harvesting, those in Makueni (73.3%) and Machakos (76.6%) perceived that conflicts over sand harvesting were either somewhat becoming prevalent or were becoming more and more prevalent.

Basing on what has been observed in the findings in the last 5 years; climate-related conflicts are something to worry about. There are more conflicts over resources in both Makueni and Machakos where climate is harsh as compared to Kiambu where climate conditions are friendlier. The implication here is that the climate change being experienced across the world is likely to lead to increased conflicts.

A one-way multivariate analysis of variance (MANOVA) between subjects, design was used to investigate whether the observed differences in participants' perceptions of prevalence of resource-based conflicts, perceptions of contributions of climate change to perceived resource-based conflicts, and perceived measures by the government to mitigate conflicts differed statistically across the three regions. The two dependent variables were: (i) composite indicator of perceived resource-based conflicts, (ii) composite indicator of perceived contribution of climate change to resource-based conflicts. The independent variable was the study region with three levels, Makueni, Machakos, and Kiambu. Results show that the differences in perceived resource-based conflicts are statistically significant  $F_{2, 76} = 12.78$ ,  $p < 0.01$ . Residents of Machakos county have a considerably higher perception that resource-based conflicts had risen during the last 5 years,  $M = 3.90$ , followed by

**Table 3** Citizens perceptions of the prevalence of resource-based conflicts

Would say climate change is contributing a lot or not at all to the following conflicts?	Does not contribute at all <b>1</b> (%)	Somewhat less <b>2</b> (%)	Unsure <b>3</b> (%)	Somewhat contribute more <b>4</b> (%)	Contributes a lot <b>5</b> (%)
<b>A)</b> Conflicts related to scarcity of firewood, such as people illegally collecting/harvesting firewood in neighbors' farms, quarrelling over collection of firewood	Makueni 20.0 Machakos 0.0 Kiambu 64.0	6.7 3.3 24.0	3.3 3.3 4.0	30.0 50.0 8.0	40.0 43.3 0.0
<b>B)</b> Conflicts related to scarcity of water, such as fights over water at water collection points, quarrelling over water queues	Makueni 6.7 Machakos 0.0 Kiambu 80.0	0.0 3.3 12.0	6.7 3.3 4.0	30.0 36.7 0.0	56.7 56.7 4.0
<b>C)</b> Conflicts related to scarcity of water for livestock, such as people illegally watering their livestock in someone's water point	Makueni 16.7 Machakos 0.0 Kiambu 68.0	6.7 3.3 16.0	13.3 16.7 12.0	26.7 33.3 4.0	36.7 46.7 0.0
<b>D)</b> Conflicts related to scarcity of grazing pastures, such as animals straying into neighbors' farms/ plots in search for grazing pasture	Makueni 6.7 Machakos 0.0 Kiambu 64.0	10.0 10.0 32.0	3.3 3.3 0.0	30.0 30.0 4.0	50.0 56.7 0.0
<b>E)</b> Conflicts related to scarcity of grazing pastures, such as people illegally harvesting grazing materials in a neighbor's land/pasture	Makueni 10.0 Machakos 0.0 Kiambu 76.0	6.7 0.0 20.0	10.0 10.0 0.0	33.3 46.7 4.0	40.0 43.3 0.0
<b>F)</b> Conflicts related to scarcity for food, such as neighbors and other people illegally harvesting food resources in a neighbor's farm	Makueni 6.7 Machakos 3.3 Kiambu 82.6	16.7 10.0 13.0	6.7 16.7 0.0	33.3 40.0 0.0	36.7 30.0 4.3
<b>G)</b> Conflicts related to scarcity of building materials, such as people illegally harvesting thatch grass or building wood in a neighbor's farm	Makueni 23.3 Machakos 6.7 Kiambu 80.0	16.7 30.0 12.0	20.0 13.3 4.0	13.3 30.0 4.0	23.3 20.0 0.0
<b>H)</b> Conflicts over sand harvesting	Makueni 13.3 Machakos 6.7 Kiambu 92.0	13.3 3.3 4.0	0.0 13.3 4.0	13.3 33.3 0.0	60.0 43.3 0.0

**Table 4** Relationship between citizens perceptions by region

Source	Dependent variable	Sum of squares	Df	Mean square	F	Sig
Region	Prevalence of climate change-induced resource-based conflicts	24.465	2	12.73	12.78	0.01
	Contribution of climate change to resource-based conflicts	114.41	2	57.21	44.07	0.01
Error	Prevalence of climate change-induced resource-based conflicts	75.72	76	1		
	Contribution of climate change to resource-based conflicts	98.65	76	1.30		
Total	Prevalence of climate-change-induced resource-based conflicts	1035.97	79			
	Contribution of climate change to resource-based conflicts	1094.45	79			

Makueni,  $M = 3.6$ , Kiambu residents do not consider resource-based conflicts to have been on the rise during the last 5 years,  $M = 2.4$ . Post-hoc tests using Turkey HSD revealed that the difference between perceptions from Kiambu differed statistically from those of Machakos, and also statistically from those from Makueni residents.

Results also show that the differences of perceptions in climate change as a contributor to the perceived rise in resource-based conflicts are statistically significant  $F_{2,76} = 44.07, p < 0.01$ . Residents from Machakos county have a considerably higher perception that climate change is contributing to the rise in resources-based conflicts in Machakos county,  $M = 4.0$ . Results show that Makueni follows with a relatively modest perception of climate change as a contributor to the perceived rise in resource-based conflicts,  $M = 3.99$ . Climate change is not regarded as a contributor to resource-based conflicts in Kiambu county,  $M = 1.2$ . Post-hoc tests using Turkey HSD revealed that the difference between perceptions from Kiambu differed statistically from those of Machakos, and also statistically from those from Makueni residents (Table 4).

## Conclusion

This chapter explored the extent of climate change-induced resource conflicts along an hydrological gradient in three counties in Kenya, namely, Kiambu County which experiences relatively high rainfall and also high urban population, Machakos County, which generally experiences modest rainfall availability, and Makueni County regarded to be one of the most arid and semiarid counties in Kenya. Variability in the severity of climate change-induced resource-based conflicts was evident in counties along rainfall availability gradient. The impacts of climate change can be diverse, particularly for vulnerable regions such as arid and semiarid regions such as Makueni County. Respondents from Makueni County mentioned the

highest number of climate-related impacts in the county, with the most frequently mentioned impact being increasing food insecurity followed by increasing water shortages. Machakos followed with respondents mentioning seven impacts that included increased water shortages and scarcity of pasture. In Kiambu County, only four impacts were mentioned with food insecurity being frequently mentioned among the list of impacts of climate change in the county. Results of the descriptive and inferential statistics reveal that resource-based conflicts vary along the hydrological gradient. Residents in Machakos County perceived resource-based conflicts to have risen quite significantly during the last 5 years, compared to perceptions from Makeni County. Kiambu residents did not consider resource-based conflicts to have risen during the last 5 years. Also, residents of Machakos County perceived climate change to be a factor in the rise of resource-based conflicts compared to perceptions from their counter parts from Makeni County. Although Makeni is the driest of the three counties, the publicity of the government's investments towards climate change mitigation and adaptation offers a possible explanation on the differences in survey results compared to residents' perceptions from Machakos County.

---

## Suggestions for Further Research

Follow up research is needed to examine if survey results correlate with field observations in terms of reported climate change resource-based conflicts, different government and nongovernment agencies' investments and expenditures on climate change mitigation and adaptation, especially citizens participation in those projects. In addition, further studies are needed to investigate the self-reported food insecurity associated with climate change, the coping capacity under different resource, socio-economic and sociocultural settings, the consequences on malnutrition particularly on vulnerable population, and impacts on population health.

---

## References

- Agnew R (2012) Reflection on "A revised strain theory of delinquency". *Soc Forces* 91(1):33–38. Researchgate
- Benjaminsen TA, Ba B (2009) Farmer–herder conflicts, pastoral marginalisation and corruption: a case study from the inland Niger Delta of Mali. *Geogr J* 175(1):71–81. <https://doi.org/10.1111/j.1475-4959.2008.00312.x>. Wiley Press Room, Published online
- Benjaminsen TA, Maganga FP, Abdallah JM (2009) The Kilosa killings: political ecology of a farmer–herder conflict in Tanzania. *Dev Chang* 40(3):423–445. <https://doi.org/10.1111/j.1467-7660.2009.01558.x>. Wiley Online Library
- Folami OM, Folami AO (2013) Climate change and inter-ethnic conflict in Nigeria. *Peace Rev* 25(1):104–110. <https://doi.org/10.1080/10402659.2013.759783>. Published online
- GoK. (2019). 2019 Kenya Population and Housing Census Volume I: Population by County and Sub-County. Government Printer. <https://www.knbs.or.ke/?wpdmpro=2019-kenya-population-and-housing-census-volume-i-population-by-county-and-sub-county>

- Hadush M (2018) Welfare and food security response of animal feed and water resource scarcity in Northern Ethiopia. *Agric Food Econ* 6(1):22. <https://doi.org/10.1186/s40100-018-0116-2>. Norwich
- Hussein K, Sumberg J, Seddon D (1999) Increasing violent conflict between herders and farmers in Africa: claims and evidence. *Dev Policy Rev* 17(4):397. Blackwell Publishers Ltd
- Ifejika Speranza C (2010) Drought coping and adaptation strategies: understanding adaptations to climate change in agro-pastoral livestock production in Makueni District, Kenya. *Eur J Dev Res* 22(5):623–642. <https://doi.org/10.1057/ejdr.2010.39>. Bonn
- Kuhlmann M, Guo D, Veldtman R, Donaldson J (2012) Consequences of warming up a hotspot: species range shifts within a centre of bee diversity. *Divers Distrib* 18(9):885–897. <https://doi.org/10.1111/j.1472-4642.2011.00877.x>. Blackwell Publishing Ltd
- Meierding E (2013) Climate change and conflict: avoiding small talk about the weather. *Int Stud Rev* 15(2):185–203. <https://doi.org/10.1111/misr.12030>
- Peters K, Mayhew L (2019) Climate change, conflict and security scan. Overseas Development Institute, London, p 57
- Price R (2019) Climate change as a driver of conflict in Afghanistan and other fragile and conflict affected states. Institute of Development Studies, vol 18. Assets Publishing Service, Brighton, UK
- Scott SV, Andrade RCD (2012) The global response to climate change: can the security council assume a lead role? *Brown J World Aff* 18(2):215–226. University of New South
- Serdeczny O, Adams S, Baarsch F, Coumou D, Robinson A, Hare W, ... Reinhardt J (2017) Climate change impacts in sub-Saharan Africa: from physical changes to their social repercussions. *Reg Environ Chang* 17(6):1585–1600. <https://doi.org/10.1007/s10113-015-0910-2>. Berlin
- Sunga LS (2014) Does climate change worsen resource scarcity and cause violent ethnic conflict? *Int J Minor Group Rights* 21(1):1–24. <https://doi.org/10.1163/15718115-02101001.CNA>
- Watson EE, Hussein Kochore H (2012) Religion and climate change in Northern Kenya: new moral frameworks for new environmental challenges? *J Study Relig Nat Cult* 6(3):319–343. <https://doi.org/10.1558/jsmc.v6i3.319>. Equinox Publishing, Sheffield
- Witsenburg KM, Adano WR (2009) Of rain and raids: violent livestock raiding in Northern Kenya. *Civil Wars* 11(4):514–538. <https://doi.org/10.1080/13698240903403915>. Halle/Saale

**Open Access** This chapter is licensed under the terms of the Creative Commons Attribution 4.0 International License (<http://creativecommons.org/licenses/by/4.0/>), which permits use, sharing, adaptation, distribution and reproduction in any medium or format, as long as you give appropriate credit to the original author(s) and the source, provide a link to the Creative Commons license and indicate if changes were made.

The images or other third party material in this chapter are included in the chapter's Creative Commons license, unless indicated otherwise in a credit line to the material. If material is not included in the chapter's Creative Commons license and your intended use is not permitted by statutory regulation or exceeds the permitted use, you will need to obtain permission directly from the copyright holder.





# Mainstreaming Climate Adaptation in Mozambican Urban Water, Sanitation, and Drainage Sector

# 128

Pedro Muradás, María Puig, Óscar Ruiz, and Josep María Solé

## Contents

Introduction .....	2632
Institutional Strengthening .....	2634
Capacity Building .....	2636
Resilient Urban Water Management Studies .....	2648
Conclusions .....	2649
Recommendations and Further Steps .....	2650
References .....	2651

## Abstract

The Capacity Development Programme (CDP) is an agreement between the Government of Mozambique and the Nordic Development Fund, to tackle climate variability by planning and the sustainable operations and maintenance of sanitation and drainage infrastructure. The Mozambican Administration of

This chapter was previously published non-open access with exclusive rights reserved by the Publisher. It has been changed retrospectively to open access under a CC BY 4.0 license and the copyright holder is “The Author(s)”. For further details, please see the license information at the end of the chapter.

P. Muradás (✉)

IDOM, Consulting, Engineering, Architecture SAU, Madrid, Spain

Urban and Territorial Planning Department, Universidad Politécnica de Madrid. Escuela Técnica Superior de Arquitectura, Madrid, Spain

e-mail: [pmum@idom.com](mailto:pmum@idom.com)

M. Puig · Ó. Ruiz

IDOM, Consulting, Engineering, Architecture SAU, Madrid, Spain

e-mail: [maria.puig@idom.com](mailto:maria.puig@idom.com); [oruiz@idom.com](mailto:oruiz@idom.com)

J. M. Solé

Meteosim SL. Barcelona Science Park, Barcelona, Spain

e-mail: [jmsole@meteosim.com](mailto:jmsole@meteosim.com)

© The Author(s) 2021

W. Leal Filho et al. (eds.), *African Handbook of Climate Change Adaptation*,  
[https://doi.org/10.1007/978-3-030-45106-6\\_132](https://doi.org/10.1007/978-3-030-45106-6_132)

2631



Water and Sanitation Infrastructure (AIAS) is the agency responsible for this project. The international consortium in charge of developing the CDP provided consultancy services to AIAS and the vulnerable cities of Beira and Matola. The assignment included not only capacity building but also institutional strengthening activities, as well as specific studies, mainly based on climate modelling (dynamic downscaling) and mapping exercises. Important results and conclusions were achieved, and further adaptation strategies to increase the resilience of the Mozambican urban water, sanitation, and drainage sector were proposed.

---

**Keywords**

Adaptation · Urban water · Sanitation and drainage · Mozambique · Climate modelling · Adaptation options

---

**Introduction**

Mozambique is one of the top three among African countries most exposed to multiple weather-related hazards (GFDRR 2016). The country is located downstream of nine major international river basins, with extensive areas classified as arid or semiarid, and stretches of coastline on the path of tropical systems formed in the Indian Ocean. Vulnerable population, services, and assets are regularly exposed to floods and droughts, often severely. The devastating effects of Idai and Kenneth, the two intense tropical cyclones that in March and April 2019 struck central and northern provinces, will remain for a long time. According to the assessments published by the Government of Mozambique (GoM), a total of 2.8 million people were affected (GoM 2019a), with recovery and reconstruction works estimated at a total of US\$ 3.2 billion (GoM 2019b). Before these events, the country was already facing high levels of food insecurity. Between September and December 2018, 1.78 million people suffered severe food insecurity in the country (GoM 2019b). Although the provinces most affected by these events tend to show higher levels of poverty compared to those least affected (Baez et al. 2018), natural disasters may challenge development of Mozambique as a whole.

Climate variability is already modifying the regional patterns of those extreme events. During the period 1960–2005, significant positive trends in temperature change were observed across most of the country and in all four seasons (INGC 2009). Rainy seasons commenced later, and dry spells lasted longer. As a result, over the past decades, the country has experienced increased droughts, flooding, and storms.

Climate scenarios vary across models depending on assumptions; however, most climate models suggest increases in mean annual temperatures, extended dry periods, more intense storms, and sea level rise (USAID 2012). As a result of climate change, the exposure to natural disaster risk in Mozambique will increase significantly over the coming 20 years and beyond (INGC 2009). Unless adaptations strategies are implemented, relative to baseline growth in 2003, gross domestic product could fall between 4% and 14% in the period 2040–2050 (WB 2010).

Moreover, given that Mozambique is such a poor country, under a “business as usual” scenario, climate change will impact even greater on the economy, driving the majority of the poor people into further poverty (Irish Aid 2018). There is a need to design effective mechanisms to address the risks and disasters associated with climate change by introducing inclusive and climate-resilient economic models that could increase income and generate social cohesion.

Climate change adaptation is being tackled by the GoM through different ongoing policies. As a “Least Developed Country” in the United Nations Framework Convention on Climate Change (UNFCCC), Mozambique published a National Adaptation Programme of Action (NAPA) in 2007. The NAPA outlined four specific actions, which aim to reduce the negative impacts of extreme hydrometeorological events through adaptation initiatives. Two of the program’s prioritized strategies are reducing the impact on coastal zones and improving the management of water resources against climate change (MICOA 2007).

In 2012, the National Climate Change Strategy (NCCS) 2013–2025 was launched. Under the adaptation pillar of the strategy, several areas for intervention and consequent actions were identified. In terms of water resources, the strategy proposes, among other recommendations, improving rainwater drainage and sanitation systems (GoM 2012).

Mozambique ratified the Paris Agreement in 2017, and the country is defining the specific action for different goals proposed in the Intended Nationally Determined Contribution (INDC) submitted to UNFCCC in 2015 (MITADER 2015). The INDC reinforces NCCS objectives, to be implemented between 2020 and 2030. The first NDC is currently under development.

In addition, the National Disaster Risk Reduction Master Plan 2017–2030 is well-aligned with the adaptation priorities of the NCCS. The plan’s main objective is to improve the resilience for population, livelihoods, health, and infrastructures, through an established culture of prevention, preparedness, response, and recovery (GoM 2017).

To carry out these climate policies, the GoM is drawing on both national resources and external aid. The country has attracted strong donor support for reconstruction and development over the last two decades and continues to obtain high volumes of international cooperation (Irish Aid 2018).

In this sense, the Cities and Climate Change Project (CCCP), developed in recent years with the aid of the World Bank, is one of the most important international cooperation initiatives undertaken in the country. The objectives of the CCCP include reducing disaster risks in urban areas and vulnerability associated with the impact of climate related. The project was approved in 2012 and finalized in 2019. Key analytical and infrastructure works to achieve the objectives were financed by the Bank. The CCCP had two components. Component 2, specifically aimed at increasing resilience in the cities of Maputo and Beira, was implemented by the Administration of Water and Sanitation Infrastructure (AIAS). AIAS was created in 2009, under the authority of the Ministry of Public Works and Housing, to manage urban water and sanitation investments, including drainage in small- and medium-sized cities.

In terms of the agreed priority actions and building on synergies within Component 2 of the CCCP, the Nordic Development Fund (NDF) approved parallel co-financing of this World Bank project. The Grant Agreement between NDF and the GoM was signed at the end of 2012 (NDF 2015). The NDF support, called “Capacity Development Programme (CDP),” was aimed at enabling AIAS (the national counterpart) and the municipal autonomous water and sanitation services of two selected cities (Beira and Matola), within their mandate, to act on climate variability.

The international consortium comprising of IDOM (leader), Nordic Consulting Group, Meteosim, and COBA was in charge of implementing the CDP. This 26-month technical assistance (September 2017–December 2019) project greatly benefited AIAS and other relevant stakeholders.

This chapter summarizes the activities and results of the Capacity Development Programme (CDP).

---

## Institutional Strengthening

Resilience must be understood at country level involving all institutions and agencies together, in which stakeholders, decision-makers, officials, and other relevant stakeholders should understand the concept and how to put it into practice along with their specific tasks. This is the case in Mozambique, where an articulated vision of adaptation, disaster risk management, and resilience is still a challenge for national institutions (UNDP 2019).

The CDP has contributed to narrowing these gaps, with the completion of important activities.

In the first stage, a complete stakeholder mapping exercise was carried out (summarized in Table 1), including an assessment of the existing institutional influence on the decision-making processes in relation to resilience. It should be noted that a number of national agencies participate in the management of water cycle.

To develop skills in relation to resilience in AIAS, the institution needed access to available data and information on climate variability as well as coordination and cooperation with key institutions involved in climate change adaptation. The CDP facilitated inter-institutional linkages. Collaboration agreements were signed with the Ministry of Environment (MITADER), INGC, INAM, and INAHINA.

The two components or products specifically developed to improve AIAS managerial activities were an institutional website ([www.aias.gov.mz](http://www.aias.gov.mz)) and a decision support system (DSS) based on a geographic information system (GIS) (Fig. 1). The new website serves as a platform to effectively publish the activities of the institution. The website also features internal management utilities, such as the possibility of remote access to information networks (intranet) and projects or shared resources. In terms of the GIS-DSS application developed, as a first step, the geo-referenced infrastructure database managed by AIAS was included and adapted. Following this, an analysis module of the vulnerability of receptors (population and assets) sensitive

**Table 1** Key actors involved in water, sanitation, and hygiene (WASH) sector resilience (acronyms in Portuguese)

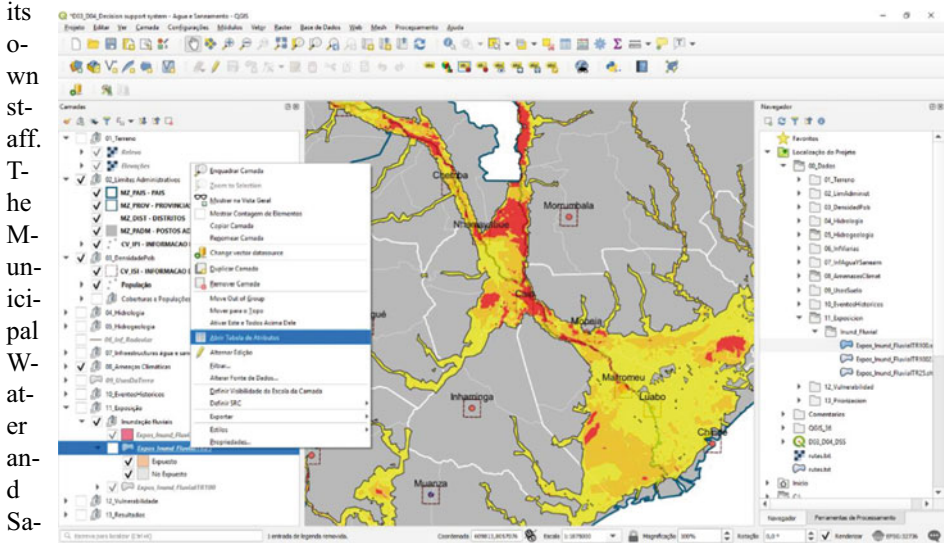
Institution/agency	Role/duties	Influence
National Directorate for Water Resources Management (DNGRH)	Water resources policies, regulations, and infrastructures	Medium
National Directorate for Water Supply and Sanitation (DNAAS)	Water supply, sanitation and drainage policies, regulations, and infrastructures in rural settlements	High
Water-Supply Asset Holding and Investment Fund (FIPAG)	Management of public investments in water systems for major urban areas	Medium
Administration of Water and Sanitation Infrastructure (AIAS)	Development of water and sanitation and drainage infrastructure in attributed secondary towns outside the FIPAG remit	High
Water Regulatory Authority (AURA, former CRA)	Urban water regulatory agency (tariffs approval, quality of service compliance)	Medium
Regional Water Administrations (ARAs)	There are four of them covering the country area (South, North, Center, Zambezi), assuming decentralized duties	Medium
Private agents	Contractors in public infrastructures and water systems for some urban areas	Low
Ministry of Health	Water supply quality standards	Low
National Directorate of Environment	Climate change policies. Focal point to UNFCCC	Very high
Natural Institute of Disaster Management (INGC)	Coordination of DRM policies and activities. Promote development in arid zones	Very high
National Institute of Meteorology (INAM)	Weather forecasts and seasonal outlooks. Alerts. Meteorological data register and exploitation	Medium
National Institute of Hydrography and Navigation (INAHINA)	Oceanography (marine weather), coastal protection, and navigation support	Low
Cities	Urban sanitation. Rural and urban water and sanitation	Low

Source: Authors, based on WB (2018)

to floods and droughts was designed. This tool also integrates geographic information provided by other institutional sources and a historical record of extreme events. The vulnerability module allows the different factors that determine the sensitivity and adaptive capacity of considered receptors to be classified/categorized. The DSS was designed using open-source GIS software. The objective of this tool was to provide support to AIAS in prioritizing new water and sanitation projects as well as operational and maintenance tasks, taking into account the climate risk component. Both products (website and GIS-DSS) were backed up with manuals on operation procedures.

Beira and Matola were the subjects of specific institutional strengthening activities. Both cities have their own water and sanitation services, which required strategic support in terms of organization and finance. In Beira, the Autonomous

Sanitation Service (SASB) was established by the municipality in 2008 and currently has its own staff. The Municipal Water and Sanitation



**Fig. 1** GIS-based decision support system. (Source: Authors)

Entity (EMAS) of Matola was constituted in 2016 and is still under development with the objective of fully addressing its agreed responsibilities. An output of the CDP was adjusted business development plans for both SASB and EMAS, including resources and recommendations on diverse key items: rates, investments, resources, organizational chart, financial scenarios, accountability practices, additional sources of finance, or key performance indicators.

Institutional strengthening activities for AIAS, SASB, and EMAS followed a knowledge, attitude, and practice (KAP) approach. Under this methodology, the baseline study provided a good framework for defining capacity building activities and goals. One of the conclusions of the mapping exercise was that from the perspective of capacity development needs, there was limited knowledge among the Mozambican institutions interviewed about climate change phenomenon and its potential consequences. After defining the existing state of the intuitions, the technical needs identified set the basis for the design of a training program which was appropriate for each.

## Capacity Building

One of the main targets of the CDP was to achieve the effective transfer of technical skills in relation to climate impact to the AIAS, municipalities, and other key stakeholders dealing with planning and management.

Water is the common denominator of the climate system (atmosphere, hydrosphere, cryosphere, land surface, and biosphere). Therefore, climate change affects water through a number of mechanisms (Bates et al. 2008) with a growing and significant impact on both the supply and demand of water, sanitation, and hygiene (WASH) delivery systems (Batchelor et al. 2011). These impacts are especially severe in African cities, with direct effects that affect people's health through waterborne diseases, damage to food, loss of income and the deterioration of sanitation, increased exposure to disease, and temporary reduction of access to health-care facilities (ActionAid 2006). Therefore, the WASH sector is highly vulnerable to potential climate effects.

Possible changes affecting WASH systems that could be expected in a changing climate can be grouped into four categories or drivers: (1) increased intensity of rainfall, (2) greater rainfall variability, (3) longer-term decline in rainfall, and (4) sea level rise. Table 2 presents the associated threats and potential impacts for each.

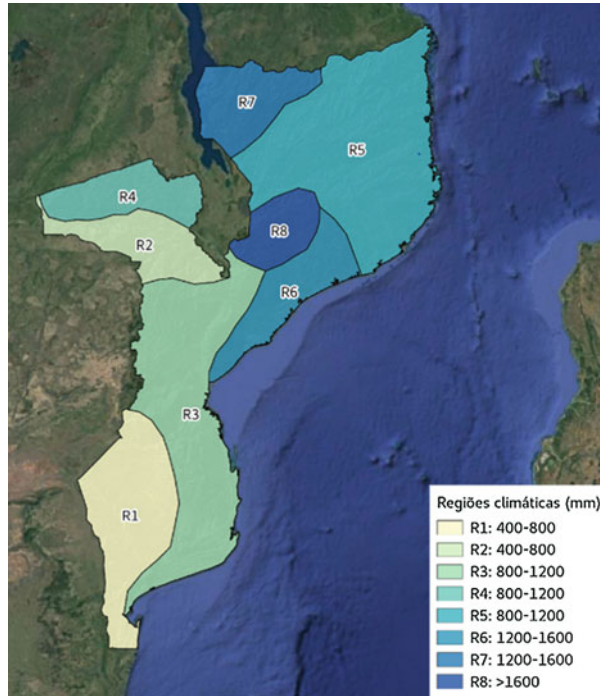
Most of these impacts are present in Mozambique. During the development of the CDP, workshops were held in Maputo and Beira where these impacts were discussed (Table 5). It is worth noting that transboundary effects were repeatedly mentioned, as the country has to deal with the effects of practices carried out upstream in the shared basins. When towns and cities experience flooding from major rivers overtopping their banks, flood protection is considered in the context of the entire river basin, and this may include more than one state (ActionAid 2006). On the contrary, some possible positive effects associated with climate variability were identified during the workshops, such as the increased availability of water in the country's dams or the opportunity to develop new technologies in the country (sea water desalination for consumption).

In order to get a clearer picture of the future climate conditions in Mozambique and their related potential impacts on WASH systems, a specific climate modelling exercise was developed within the scope of the CDP. A good assessment of past and future climate conditions serves as input for the subsequent vulnerability analysis and risk assessment.

The climate in Mozambique varies depending on the location and the time of the year. This variability is due to the interaction of different factors, namely, the atmospheric systems and the topography of the country (INAM 2019). For the analysis, eight different climate regions were defined for the development of the CDP (Fig. 2, Table 3), considering certain uniformity in the aforementioned factors.

In terms of variability over time, the annual cycle has two seasons: the rainy season starts, approximately, in November and finishes in April, while the dry season starts in May and finishes in October. This variability is due to the shift of the Intertropical Convergence Zone (ITCZ), which is located very close to the country during the November-April period, and reaches the latitudes of Mozambique around January and February, when maximum precipitation is normal. Interannually, Mozambique is influenced by the El Niño–Southern Oscillation (ENSO), in which sea surface temperature (SST) positive anomalies in the Tropical Pacific Ocean are well correlated with dry conditions, especially in central and southern Mozambique. As concluded from the 5th IPCC report (Stocker et al. 2013), significant changes in

**Fig. 2** Representation of climate regions in Mozambique.  
(Source: Authors)



ENSO are not conclusive, although there is a high confidence that ENSO will remain a dominant mode of natural variability in the twenty-first century.

Precipitation was selected as the meteorological variable most affected during flooding in the coastal cities of Mozambique. The intention of this study is to analyze the change of climatological patterns in this variable at national level and also at local level in Beira and Matola.

To assess historical changes in climate, consistent long-term meteorological observations were necessary. Since the weather station network in Mozambique is reduced (INGC 2009), with only one station per 29,000 km<sup>2</sup> and major geographical gaps in the provinces of Gaza and Tete, an alternative historical climatological database was necessary as a reference. Climate Forecast System Reanalysis (CFSR, Saha et al. 2010) was chosen as the most suitable gridded database without gaps in the historical climatology.

There are many climate scenarios as a result of running different models over long periods of time, developed by research institutes around the world, that can be used to assess the future climate. Global climate models (GCMs) are freely available through the Coupled Model Inter-comparison Project Phase 5 (CMIP5, Taylor et al. 2012), and regional climate models (RCMs) are available through the Coordinated Regional Climate Downscaling Experiment (CORDEX (<http://www.cordex.org/>)). However, due to their spatial resolution (around 100 km for CMIP5 models and 50 km for CORDEX models), they are still not capable of representing the local climate phenomena, potentially underestimating climate extremes, especially when

**Table 2** Climate impacts on WASH systems

Driver	Associated threat	Potential impacts
Increased intensity of rainfall	Flash flooding	Direct damages/losses to facilities
		Ingress of groundwater into pipe networks, septic tanks, and pit latrines
		Peaks in diarrheal diseases
		Need of modifying design standards in sanitation and drainage infrastructures
	Greater peak runoff	Erosion (direct damages/losses)
		Transport of sediments and contaminants into water bodies and groundwater
Greater rainfall variability	Longer and/or more frequent meteorological droughts	Loss of quantity and quality of resources
		Low soil moisture (agricultural drought)
		Peaks in hygiene diseases
	Increased frequency of flooding	Loss of efficiency of certain infrastructures (e.g., waste water treatment plants)
		See “Flash flooding” above
Longer-term decline in rainfall	Reduction in river flows (hydrological drought)	Loss of capacity of surface water to dilute, attenuate, and remove pollution
		Increased algal growth in surface water and reservoirs
	Alteration of groundwater recharge rates	Loss of quantity and quality of resources
Sea level rise	Saline intrusion	Loss of quantity and quality of resources
	Coastal occupation	Direct damages/losses
	Erosion	Need of additional solutions on coastal protection

Source: Authors, based on Oates et al. (2014) and Charles et al. (2010)

topography is locally complex and land uses are varying depending on the location. Aligned with the data needs of the CDP, this study was focused on the generation and analysis of higher resolution climate change scenarios: 9 km resolution dataset for Mozambique in its entirety and 3 km resolution dataset for the city of Beira.

The new climate scenarios were generated based on a dynamic downscaling approach using the Weather Research and Forecast (WRF) model and its ARW solver (Advanced Research WRF), supported by the NCAR Mesoscale and Microscale Meteorology Laboratory. In contrast with other downscaling approaches, dynamic models like WRF solve the non-hydrostatic Euler equations governing atmospheric dynamics over a limited area at very high resolution. Indeed, the WRF model is able to solve atmospheric dynamics using multiple key parametrizations such as microphysics, radiation, cumulus, surface, and planetary boundary layer (PBL) and whose proper setup is of paramount importance to optimize the performance of the model. In this sense, several experiments were evaluated following a standardized methodology defined by Arasa et al. (2016), choosing the most convenient WRF options to minimize the error in the mean precipitation and the percentile 90th (P90) of daily precipitation, as



**Table 3** Climate regions in Mozambique

Climate region	Description
R1	R1 comprises almost the whole provinces of Maputo and Gaza, in which topography is not complex and maximum altitude is around 500 m in the western part. The climatology is dry and hot and annual precipitation is normally below 600 mm/year
R2	R2 comprises the southern part of the Tete province, in which the topography is governed by the Zambezi river basin. The predominant climate is semiarid and hot and annual precipitation is normally below 800 mm/year
R3	R3 comprises Inhambane, Sofala, and Manica, whose topography is almost plain, except Manica with elevations between 600 and 1600 m. The climatology is close to tropical savanna and annual precipitation is around 1200 mm/year
R4	R4 comprises the northern part of the Tete province, in which the topography is mountainous, limited by the Cahora Bassa lake in the south. The elevations are over 2000 m at the northern boundary. The annual precipitation is over 1200 mm/year in spatial average and over 1600 mm/year in the higher areas
R5	R5 comprises Cabo Delgado, Nampula, the southeast of Nassa, and a coastal area of Zambézia. Orography is over 1000 m and annual precipitation is around 1200 mm/year
R6	R6 comprises the lower course of the Zambezi and Licungo rivers, which results in a plain topography. Precipitation is around 1200 mm/year in spatial average, although 1600 mm/year are reached in the north of the region
R7	R7 covers the northwest of Niassa and has a complex topography. The climatology is wet subtropical, and precipitations reach in average 1600 mm/year
R8	R8 is the wettest region and its topography is complex (Namuli mountains) whose highest points are the Mount Namuli (2700 m). The annual precipitation is 1600–1800 mm/year

Source: Authors

proxy of extreme precipitation. The resultant optimized WRF configuration is shown in Table 4 (central and right columns).

The WRF model was used to downscale some GCMs from CMIP5 ensemble as well as CFSR. Due to computational limitations, the three most appropriate GCMs (among tens of models available) were chosen to be downscaled from CMIP5 ensemble, according to a comprehensive validation of GCM precipitation patterns over Mozambique area. As a result, MPI-ESM-MR (Giorgetta et al. 2013), IPSL-CM5A-MR (Dufresne et al. 2013), and CanESM2 (<https://www.canada.ca/en/environment-climate-change/services/climate-change/science-research-data/modeling-projections-analysis/centre-modelling-analysis/models/second-generation-earth-system-model.html>) were selected. The validation consisted of analyzing the performance of annual cycle bias as well as spatial correlation in Mozambique's annual precipitation cycle of each CMIP5 model against the GPCC precipitation dataset (Global Precipitation Climatology Center). (GPCC global dataset were used in order to keep the same grid scale between climate models and observations in the validation exercise.) The results of the GCM validation exercise are shown in Fig. 3, displaying the good performance of the selected models in the annual cycle as well as in the spatial distribution in the Mozambique area. All selected models

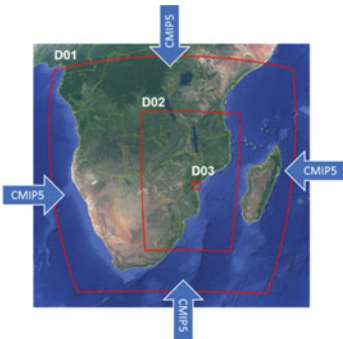
show a Pearson correlation higher than 0.98 and a normalized root-mean-square error (NRMSE) lower than 20% in the annual precipitation cycle. In the same vein, spatial distribution of precipitation climatology for the three selected models is performing correctly showing spatial correlation with GPCC higher than 0.7 for an area covering Austral Africa.

The WRF model was run considering the three previously mentioned GCMs as inputs for two different 20-year periods of time: a historical/reference period 1986–2005 using CFSR and a future period (2026–2045) using the three CMIP5 models. These periods were chosen according to the design of climate simulations within CMIP5 initiative, which define the historical period between 1850 and 2005 and future period from 2006 to 2100 under the Representative Concentration Pathway (RCP) 8.5. This RCP8.5 is considered as a “business as usual” scenario reaching a radiative forcing of  $8.5 \text{ W/m}^2$  at 2100. RCP8.5 is the most conservative scenario, since it predicts the most extreme global warming according to an increasing fossil burning and increase of greenhouse gases (GHG).

As part of WRF configuration, an optimal grid architecture is defined through three nested domains to downscale gradually the CMIP5 models (available at more than 100 km resolution); as shown in the left column of Table 4, the CMIP5 and CFSR models are used as input to the first domain D01 covering Austral Africa at a 27-km resolution. D02 is covering Mozambique at 9-km resolution, while D03 is covering the city of Beira at 3-km resolution.

The analysis of the WRF datasets is framed through the definition of a set of climate indicators, which represent the relevant climate aspects for the WASH sector, which are mean annual precipitation, annual precipitation cycle, dry spell (consecutive number of days with daily precipitation  $<1 \text{ mm}$ ), and intensity-duration-frequency curves. (IDF curves explain the relation between rainfall intensity

**Table 4** WRF running domains and options selected which optimize monthly mean precipitation

	Parametrization	WRF option
 <p>D01: 27 km resolution (Austral Africa)  D02: 9 km resolution (Mozambique)  D03: 3 km resolution (Beira)</p>	Radiation	CAM (Collins et al. 2004)
	Microphysics	WSM6 (Hong and Lim 2006)
	Cumulus	New-Tiedtke (Zhang et al. 2011)
	Surface	MM5 similarity (Monin and Obukhov 1954)
	PBL	YSU (Hong et al. 2006)

Source: Authors

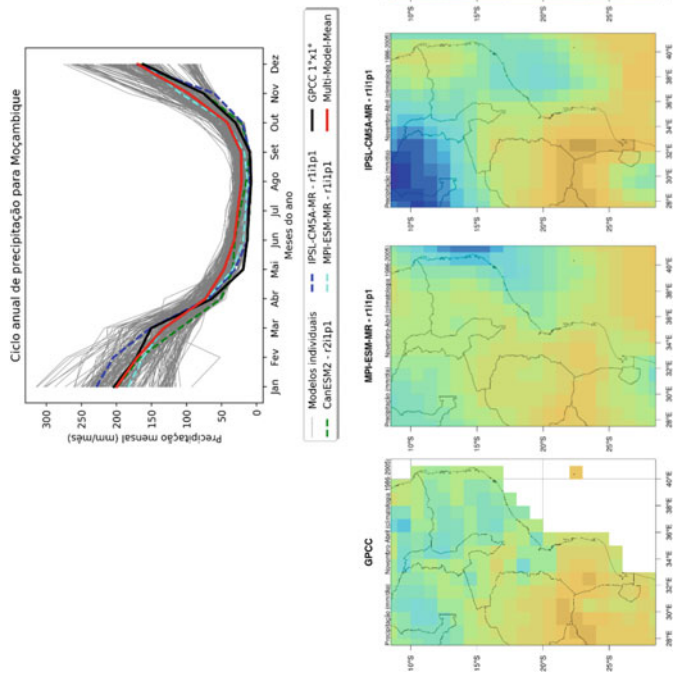
(mm/h), rainfall duration (time rained at certain intensity), and rainfall frequency or return period (time span between two consecutive rain events.) Durations from 10 min to multiple days are considered as well as recurrences from 1 to 500 years return level. The change between future and historical periods in absolute (mm) and relative (percentage) values is analyzed.

Some of the obtained results are illustrated in Fig. 4, which show the change in percentage in the climatology of annual precipitation between future and reference periods for the three downscaled models for Mozambique, Beira, and Matola. IPSL-CM5A-MR and CanESM2 indicate an increase of mean precipitation between 5% and 20% in the northern part of the country (comprising R2, R4, R5, R6, R7, and R8, located mainly in Zambézia, Niassa, and Tete provinces) and also R1 in the inner southern part of the country, while MPI-ESM-MR shows insignificant changes for those regions. By contrast, a precipitation decrease is agreed with all three models in the R3, including the provinces of Gaza and Maputo. In the city of Matola, a decrease in precipitation of between 10% and 20% is expected. Similarly, in the city of Beira, the MPI-ESM-MR and CanESM2 forecast a decrease in the mean precipitation of between 10% and 20%, whereas IPSL-CM5A-MR forecasts a decrease lower than 10%.

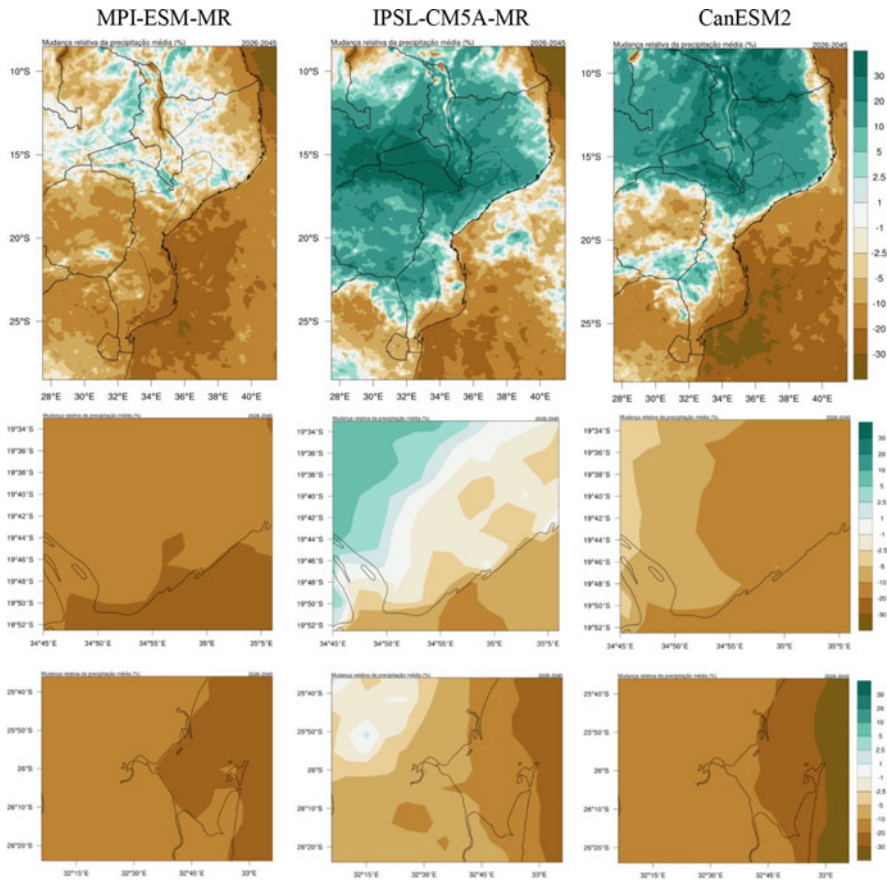
In terms of the annual variability, no significant changes are concluded from the downscaled models, which indicates that the presence of a wet season between November and April and a dry season between May and October will remain in the future. This is in line with previous studies such as GoM (2012), in which it is concluded that climate projections show a diverging change in the wet season precipitation, although they show a decrease in the dry season. In addition, the strengthening of the subtropical anticyclones during winter may lead to a delay in the southward migration of the ITCZ. It may also lead to a southward shift of midlatitude cyclones. A combination of these dynamic changes and a reduction in moisture availability during winter could lead to a delay in the start of the rains over some areas (INGC 2009).

Looking at the IDF curves, an increase in the precipitation intensity for the same return period and a general duration for all the country are agreed for all three models. The detected change is much more significant for short durations, as it is shown in Fig. 5 for 10-year return period values for Matola and Beira. This also indicates that extreme precipitation phenomena are expected to be more frequent and with a shorter recurrence time. The most abrupt changes in precipitation intensity are expected to occur in R4, R7, and R8, which corresponds to the mountainous zones of the provinces of Tete, Niassa, and Zambezia. In the case of the city of Beira, a significant increase in the precipitation intensity is detected for all return periods and durations until 1 day, although the change is much more significant for the short durations.

In terms of the projection of dry spells, an increase between 20 and 30 days in the number of consecutive dry days is agreed among the three downscaled models in the provinces of Cabo Delgado, Nampula, and the coast of Inhambane. In these areas, the number of consecutive dry days is lower than 100 in the case of Cabo Delgado and Nampula and lower than 75 in the case of Inhambane. That supposes an increase in the number of consecutive dry days in areas in the north of the country, where this phenomenon is not so frequent.



**Fig. 3** GCM validation of annual cycle of precipitation in mm/day for 1986–2005 (top, solid dark line shows GPCP, while green, blue, and cyan dashed lines show CanESM2, MPI-ESM-MR, and IPSL-CM5A-MR, respectively). GCM validation of spatial distribution of the precipitation climatology in the humid period (November to May) in mm/day (bottom, from left to right pictures show GPCP, MPI-ESM-MR, IPSL-CM5A, and CanESM2). (Source: Authors)



**Fig. 4** Change (%) in annual mean precipitation between reference (1986–2005) and future (2026–2045) periods in Mozambique (top), Beira (central), and Matola (bottom) for the three downscaled models MPI-ESM-MR (left), IPSL-CM5A-MR (central), and CanESM2 (right). Mesoscale model: WRF. RCP8.5. (Source: Authors)

Considering that modifications in design standards can substantially reduce the impacts of climate change in Mozambique, even without additional resources (WB 2010), one of the main activities carried out using the results of the climate modelling as inputs was reviewing the existing regulations, technical standards and norms, and design criteria in water, sanitation, and flood control. This task had two objectives: to identify any possible inconsistencies or gaps and include the adaptation component. A total of six official documents were analyzed:

- Water Law (Law 16/91)
- Water Policy (August 2007)
- National Strategy for Water Resources Management (August 2007)
- National Water and Sanitation Strategy 2011–2025 (January 2012)

- Regulation of Public Systems of Water Distribution and Wastewater Drainage (Decree 30/2003)
- National Program for Water Supply and Rural Sanitation (Ministerial Diploma 258/2010)

Relevant modifications were only proposed for two of these documents. Regarding the Water Law, climate change has been incorporated into water resources management, enhancing the integral management of the basins as the best way to guarantee the adequate use of these resources and emphasizing the defense of the public water domain as a preventive measure to protect them. Regulation 30/2003 is the main technical standard in force for water and sanitation projects in Mozambique. An in-depth revision was carried out, in order to include a “climate factor” within the calculation of the precipitation design value for each one of the climate regions previously defined in the climate modelling exercise. Modifications to these regulations was then proposed and subsequently reviewed and approved by AIAS and DNAAS. The bureaucratic process until the official approval and publication in an official bulletin was not completed during the development of the CDP, as a wider institutional consensus was required.

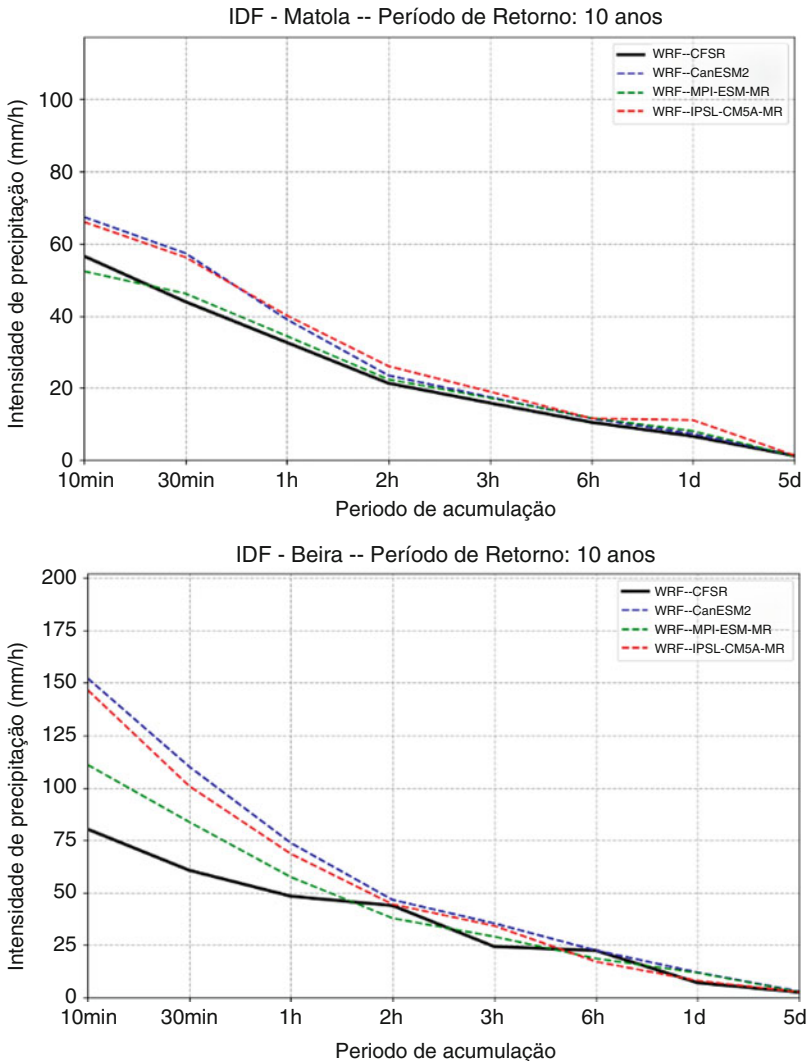
The last technical activity completed within the scope of the CDP was aimed at streamlining the process of selecting and prioritizing adaptation measures that could effectively be applied in the Mozambican urban water, sanitation and drainage sector. The existing water and sanitation facilities were found to be suitable for most climates, perhaps with minor adaptation; however, the challenge is in selecting the technology to suit the predicted future climate (Charles et al. 2010). For this purpose, a specific decision tool was implemented. Based on a multivariate matrix, the tool has been designed to be an easy-to-use worksheet (Fig. 6) that allows consultation and presents the most appropriate adaptation options according to:

- Type of adaptation measure required: planning (9 different measures), infrastructure designing (29), operation and maintenance (8)
- Related threat: flash flooding, riverine flooding, sea level rise-coastal erosion, droughts, and average temperatures raising
- Geographic scope: local or regional
- Type of infrastructure: water and/or sanitation and/or drainage

All adaptation measures are described in specific fact sheets, including widely accepted selection criteria: vulnerability, urgency, synergy, no-regret, efficacy, feasibility, flexibility, and cost-benefit (UNFCCC 2011).

In order to effectively disseminate the results of the activities mentioned above and to foster the technical capacity of AIAS and other stakeholders, a series of thematic training workshops was programmed within the CDP project. Table 5 presents the main contents of each of these workshops held in Maputo and Beira.

The number of participant institutions in the different training activities carried out was significant. In addition to the technical staff and managers of AIAS, SASB, and EMAS, representatives of DNAAS, DINAB, INAM, INAHINA, INCG, the



**Fig. 5** Change (mm/h) in the precipitation intensity between reference period (WRF-CFSR) annual mean precipitation between reference (1986–2005) and future (2026–2045) in Matola (top) and Beira (bottom) MPI-ESM-MR (green shaded line), IPSL-CM5A-MR (red shaded line), and CanESM2 (blue shaded line). Mesoscale model: WRF. RCP8.5. (Source: Authors)

ARA Center, and municipal technical professionals from Quelimane and Nacala offered regular assistance as well. The feedback received from attendants after each workshop held was satisfactory, in terms of contents, scope, training materials, and complementary resources.

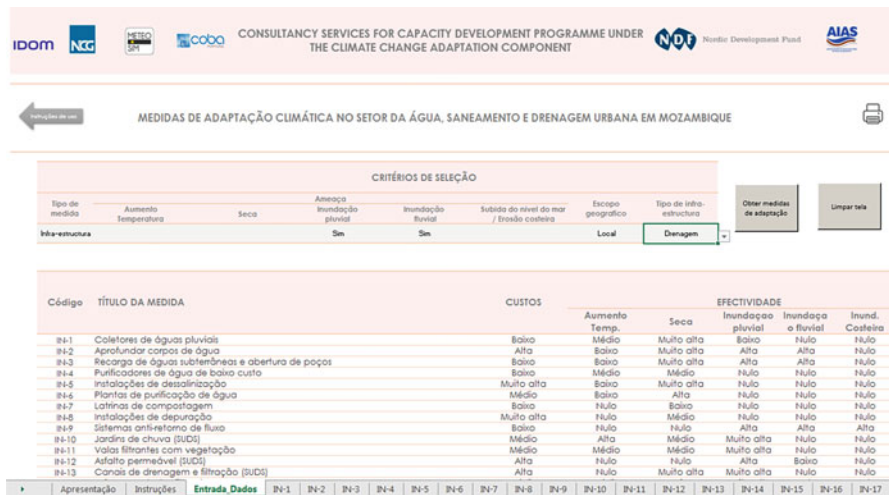


Fig. 6 Priority/decision-making tool for investments on urban water management. (Source: Authors)

Two study tours were organized in order to complete the capacity development program. The attendees were from AIAS, Beira, Matola, and other key stakeholders (ten participants each). The first trip was to Brazil, where two cities were visited. In the city of João Pessoa, some of the adaptations projects defined within the Action Plan as part of the Emerging and Sustainable Cities Initiative (ESCI) were seen. ESCI has been launched by Inter-American Development Bank in a number of Latin American and Caribbean cities, where IDOM has been actively collaborating, developing vulnerability and urban growth studies. In Rio de Janeiro, the delegation participated in the “Rio Water Week,” an important international event that served to give the group exposure to innovative initiatives and allowed them to make contact with other actors of the WASH sector. The second study tour was in Spain. The first stage of the trip included Seville, where with the collaboration of the public water and sanitation company (EMASESA), the regulatory framework of the city on drainage was shared and different infrastructures of interest (storm tanks, water and wastewater plants) were visited. In Madrid, the group was welcomed by municipal technical staff (the so-called Blue Department), who presented different projects related to sustainable urban drainage systems and held useful technical exchange sessions with Mozambican counterparts. The public company in charge of water and sanitation services in Madrid (Canal de Isabel II) also participated.

Finally, to improve the capabilities of the AIAS technical staff in the use of GIS tools, a hands-on training program “ad hoc” was organized. A specialist from the institution received specific training during the CDP project, including a 2-week internship in the GIS Division at IDOM’s headquarters in Madrid.



## Resilient Urban Water Management Studies

African countries, in particular, face twofold challenge of managing climate change risk while at the same time, using sustainable approaches to extend the services provided, housing, and infrastructure (Campos et al. 2012). Adaptation is indeed an opportunity to promote social cohesion. In this sense, the cities of Beira and Matola are representative of other urban areas in the country.

Beira is a colonial city, established as a seaport to export raw materials from the African continent. Below the sea level, the city is located on a large estuary formed by the convergence of two large rivers (Pungwe and Buzi). It is also located in the path of the periodical tropical systems formed in the Indian Ocean. The city is exposed to frequent flooding which can be very disastrous when a cyclonic situation is combined with high tide. Certain coastal areas of the city suffer high rated of erosion. The main flood protection system to protect the city from coastal hazards was constructed decades ago and has deteriorated due to limited maintenance since its construction. This system is based on a network of open channels which divide the city and are controlled by floodgates. In some cases, they are connected to the retention basins. The city was barely affected by the Idai cyclone (GoM 2019b). Fortunately, given that landfall occurred at low tide, the city did not experience widespread coastal flooding. Therefore, it is more than obvious that actions must be taken to improve the resilience in the city. This problem has been addressed for

**Table 5** Workshops held in Maputo and Beira

Topic	Main contents
Climate change	Basic concepts. Causes and consequences. International action. Presentation of national public policies and achievements exposed by DINAB/MITADER representatives
GIS. Basic concepts	Main GIS features and utilities. Projections and coordinates systems Geo-referencing. Raster and vector models. Spatial operations (geoprocessing). Layouts
Climate impacts on WASH systems	Climate risk concepts (threats, exposure, vulnerability). WASH climate vulnerability. Adaptation measures
GIS applied to hydraulic modelling	Digital elevation models. GIS hydrologic modules. Input data for hydraulic models. Outputs refinement
Climate modelling	Basic concepts on climatology and meteorology. General circulation models. Downscaling techniques (statistical, dynamic)
Urban adaptation planning	Urban planning relevance and concepts. Urban planning in Mozambique. Multidisciplinary approaches. Adaptation plans. Study cases: João Pessoa (Brazil) and Sevilla (Spain)
Adaptation measures	Sustainable Development Goals. Nature-based solutions. Sustainable urban drainage systems. Application in practice of the reviewed Regulation 30/2003, considering climate variability
Climate impacts on WASH systems	Hydrologic and hydraulic modelling. Application in practice, based on the completed drainage studies for Beira
Climate downscaling	Sharing of the obtained results from the climate modelling exercise. Operation guidelines for the climate database generated

Source: Authors

many years and various studies and projects have been carried out, funded mainly by international sources.

Matola is a city in the metropolitan area of Maputo. In the last few decades, its population has been growing exponentially due to the migratory flows both from rural areas and also from the capital city itself, since urban growth in Maputo is limited. Urban facilities do not meet the needs of this expanding residential occupancy. In particular, sanitation and drainage systems are insufficient and highly vulnerable to episodes of intense precipitation.

The CDP project has contributed to improving the urban sanitation and drainage systems of these two cities with the development of specific analysis. To achieve this, the municipal entities SASB and EMAS have been working together in agreement on the needs and action priorities of each urban area. The climate modeling that has been carried out will permit decision-makers to consider possible future impacts.

In Beira, all the completed works related to the improvement of the sanitation and drainage systems and the coast protection were firstly identified and analyzed. In the next stage, the impact of floods on the existing storm water and sanitation network in the urban and peri-urban areas of the city was assessed using climate scenarios and a combination of hydrological and hydraulic models, calibrated with existing data in order to simulate flooding scenarios. This work allowed a series of specific needs to be defined to promote and improve the system. Following a common approach with AIAS, a detailed study of the identified no-regret options was developed, improving the drainage system of a specific neighborhood in the city (Chota-Estoril). In addition, a comprehensive feasibility study (technical, economic-financial, environmental) was carried out.

The analysis and studies focusing on Matola were based on a detailed revision of the city sanitation and drainage master plan, considering the climate factor. A conclusion of this analysis is that the proposals included in the city's drainage master plan, issued in 2015, can be considered climate-proof. In addition, some improvements in technical aspects of the basic design of the sanitation and drainage system as well as some alternative solutions based on SUDS were proposed.

It may be possible to build on these activities through the projects and works, which would effectively address the needs of each urban area. In both cases, the business development plans mentioned earlier are an important component to guarantee the feasibility of the defined actions.

---

## Conclusions

According to the evaluations given by both donor agencies (the Nordic Development Fund and the World Bank) and national counterparts (AIAS and the cities of Beira and Matola), the CDP has successfully contributed to mainstreaming climate adaptation in the Mozambican urban water, sanitation, and drainage sector.

The technical output of the CDP will serve an important input for the planning and design of resilient infrastructure. The capacity building activities have served to effectively transfer knowledge and good practices to AIAS, the city of Beira and the

city of Matola, and other relevant stakeholders of the Mozambican WASH sector. To some extent, the support given during institutional strengthening will reinforce the sustainability of AIAS and other municipal entities as well as improving the success rate of their initiatives, although financial feasibility will require extensive structural reform and progress.

This type of assignment, combining institutional strengthening, capacity building and the provision of specific technical know-how, can be replicated in other African countries to promote climate resilience in other infrastructure sectors and activities.

---

## Recommendations and Further Steps

Mozambique is a country under development. In addition to those growth prospects based on an improvement in the productive activity and the sustainable exploitation of country's natural resources, international cooperation is itself a key support in order to promote new urban infrastructures and/or improve the existing ones. Climate resilience holds an important role in this support, either as principal target or as a transversal component. As an example, it is worth mentioning two recently approved support programs. One of them aims to strengthen the capacities in disaster risk management at a country level (providing effective resources for developing the National Disaster Risk Reduction Master Plan 2017–2030), and the other is focused on improving Beira's coastal protection system. For both of them, the CDP contributions will be definitely useful.

The work along more than 2 years in close collaboration with numerous Mozambican institutions gave the chance of inspiring a few ideas, proposals, or even desires that may be taken as possible future areas of interest to develop.

The first suggestion refers to explore the possibility of carrying out an institutional reformulation of the national water sector as a whole. Concentrate attributions around a fewer number of public bodies without overlooking decentralizing objectives is clearly feasible. This would ease the decision-making process regarding key aspects, such as the integration of climate concerns on policies and developments. A "hydrographic basin" management approach – including transboundary negotiations and agreements – is highly recommended.

As can be found in many other regions around the world, it is been noted that urban planning in Mozambique still does not have the necessary power to manage the "cities growing" phenomena in a proper manner. This affects negatively and doubly those who are (socioeconomically) forced to find an urban habitat in unappropriated areas, exposed to natural threats. Adaptation plans are strategic instruments that may certainly contribute to urban resilience; based on spatial risk assessments, they indicate those spaces in which it is not appropriate to develop certain land uses or activities.

Regarding international agreements and commitments assumed by Mozambique to act in climate adaptation, coordinate action within WASH sector is mandatory in order to make articulate decisions, avoid redundancies, and hold an agile sharing of information. In this sense, the creation of a "sector-based committee," with

own statutes and binding capacities, would be beneficial. In fact, this was a failed intent along CDP's enterprises, but it would be worthwhile to take this idea up in the next future.

---

## References

- ActionAid (2006) Climate change, urban flooding and the rights of the urban poor in Africa. Key findings from six African cities. ActionAid, Johannesburg
- Arasa R, Porras I, Domingo-Dalmau A, Picanyol M, Codina B, González M, Piñón J (2016) Defining a standard methodology to obtain optimum WRF configuration for operational forecast: application over the Port of Huelva (Southern Spain). *Atmos Clim Sci* 6:329–350. <https://doi.org/10.4236/acs.2016.62028>
- Baez J, Caruso G, Chiyu N (2018) Extreme weather and household well-being: evidence from multiple shocks in Mozambique. The World Bank, Washington, DC
- Batchelor C, Smits S, James AJ (2011) Adaptation of WASH services delivery to climate change and other sources of risk and uncertainty. IRC International, The Hague
- Bates B, Kundzewicz Z, Wu S, Palutikof J (2008) Climate change and water. Technical paper of the Intergovernmental Panel on Climate Change. IPCC Secretariat, Geneva
- Campos L, Ross P, Parkinson J (2012) Building climate resilience. Adapting sanitation systems to climate change through participatory research and local action in Maputo, Mozambique. ICLEI-Africa, London
- Charles K, Pond K, Pedley S (2010) Vision 2030: the resilience of water supply and sanitation in the face of climate change technology fact sheets. Robens Centre for Public and Environmental Health, University of Surrey, Guildford
- Collins W, Rasch P, Boville B, Hack J, McCaa J, Williamson D, Kiehl J, Bitz C, Lin J, Zhang M, Dai Y (2004) Description of the NCAR Community Atmosphere Model (CAM3.0). National Center for Atmospheric Research technical note, NCAR/TN-464+STR, 226pp
- Dufresne J, Foujols M, Denvil S et al (2013) Climate change projections using the IPSL-CM5 Earth System Model: from CMIP3 to CMIP5. *Clim Dyn* 40:2123–2165. <https://doi.org/10.1007/s00382-012-1636-1>
- Giorgetta MA et al (2013) Climate and carbon cycle changes from 1850 to 2100 in MPI-ESM simulations for the Coupled Model Intercomparison Project phase 5. *J Adv Model Earth Syst* 5:572–597. <https://doi.org/10.1002/jame.20038>
- Global Facility for Disaster Reduction and Recovery (GFDRR) (2016) Country adaptation profile: Mozambique. GFDRR, Washington, DC
- Government of Mozambique (GoM) (2012) National climate change mitigation and adaptation strategy. GoM, Maputo
- Government of Mozambique (GoM) (2017) National disaster risk reduction master plan 2017–2030. GoM, Maputo
- Government of Mozambique (GoM) (2019a) Annual contingency plan 2019–2020. GoM, Maputo
- Government of Mozambique (GoM) (2019b) Cyclone Idai post disaster needs assessment. GoM, Maputo
- Hong SY, Lim JO (2006) The WRF single-moment 6-class microphysics scheme (WSM6). *J Korean Meteorol Soc* 42(2):129–151. [http://www2.mmm.ucar.edu/wrf/users/phys\\_refs/MICRO\\_PHYS/WSM6.pdf](http://www2.mmm.ucar.edu/wrf/users/phys_refs/MICRO_PHYS/WSM6.pdf)
- Hong SY, Noh Y, Dudhia J (2006) A new vertical diffusion package with an explicit treatment of entrainment processes. *Mon Weather Rev* 134:2318–2341
- Irish Aid (2018) Mozambique country climate risk assessment report. Irish Aid, Dublin
- Ministry for Land, Environment and Rural Development (MITADER) (2015) Intended nationally determined contribution to the UNFCCC. MITADER, Maputo

- Ministry for the Coordination of Environmental Affairs (MICOA) (2007) National adaptation programme of action. MICOA, Maputo
- Monin AS, Obukhov AM (1954) Basic laws of turbulent mixing in the surface layer of the atmosphere. *Contrib Geophys Inst Acad Sci USSR* 151:163–187
- National Disasters Management Institute (INGC) (2009) Synthesis report. INGC climate change report: study on the impact of climate change on disaster risk in Mozambique (eds: van Logchem B, Brito R). INGC, Maputo
- National Meteorology Institute (INAM) (2019) Atlas de Precipitação de Moçambique. INAM, Maputo
- Nordic Development Fund (NDF) (2015) Terms of reference capacity development programme consultancy services. NDF, Oslo
- Oates N, Ross I, Calow R, Carter R, Doczi J (2014) Adaptation to climate change in water, sanitation and hygiene assessing risks and appraising options in Africa. Overseas Development Institute, London
- Saha S et al (2010) NCEP Climate Forecast System Reanalysis (CFSR) selected hourly time-series products, January 1979 to December 2010. Research Data Archive at the National Center for Atmospheric Research, Computational and Information Systems Laboratory, Boulder. <https://doi.org/10.5065/D6513W89>
- Stocker TF, Qin D, Plattner GK, Tignor M, Allen S, Boschung J, Nauels A, Xia Y, Bex V, Midgley PM (2013) Technical summary. In: Climate change the physical science basis. Contribution of working group I to the fifth assessment report of the Intergovernmental Panel on Climate Change. Cambridge University Press, Cambridge/New York
- Taylor KE, Stouffer RJ, Meehl GA (2012) An overview of CMIP5 and the experiment design. *Bull Am Meteorol Soc* 93:485–498. <https://doi.org/10.1175/BAMS-D-11-00094.1>
- United Nations Development Programme (UNDP) (2019) Baseline study on disaster recovery in Africa. UNDP, New York
- United Nations Framework Convention on Climate Change (UNFCCC) (2011) Assessing the costs and benefits of adaptation options. UNFCCC, Bonn
- United States Agency for International Development (USAID) (2012) Climate change adaptation in Mozambique. USAID, Washington, DC
- World Bank (WB) (2010) The economics of adaptation to climate change – Mozambique. WB, Washington, DC
- World Bank (WB) (2018) Findings of the Mozambique water supply, sanitation, and hygiene poverty diagnostic. WB, Washington, DC
- Zhang C, Wang Y, Hamilton K (2011) Improved representation of boundary layer clouds over the Southeast Pacific in ARW-WRF using a modified Tiedtke cumulus parameterization scheme. *Mon Weather Rev.* <https://doi.org/10.1175/MWR-D-10-05091.1>

**Open Access** This chapter is licensed under the terms of the Creative Commons Attribution 4.0 International License (<http://creativecommons.org/licenses/by/4.0/>), which permits use, sharing, adaptation, distribution and reproduction in any medium or format, as long as you give appropriate credit to the original author(s) and the source, provide a link to the Creative Commons license and indicate if changes were made.

The images or other third party material in this chapter are included in the chapter's Creative Commons license, unless indicated otherwise in a credit line to the material. If material is not included in the chapter's Creative Commons license and your intended use is not permitted by statutory regulation or exceeds the permitted use, you will need to obtain permission directly from the copyright holder.





# Primary Versus High School Students' Environmental Attitudes and Pro-environmental Behavior: The Case of Embu County, Kenya

# 129

Daniel M. Nzengya and Francis Rutere

## Contents

Introduction .....	2654
Literature Review .....	2656
Concept of Environmental Attitudes and Pro-environmental Behavior .....	2656
Empirical Review .....	2657
Materials and Methods .....	2659
Results and Discussion .....	2660
Perceived Prevalent Environmental Problems .....	2660
Students Environmental Attitudes (NEP Questions) .....	2660
Environmental Knowledge: <i>Perceived Seriousness of the Environmental Problems</i> .....	2661
Pro-environmental Behavior: <i>Self-Reported Willingness to Support the Government's Pro-environmental Conservation Policies</i> .....	2664
Pro-environmental Behavior: <i>Students' Self-Reported Willingness to Participate in Community-Organized Environmental Conservation Activities</i> .....	2669
Relationship Between Environmental Attitudes, Environmental Knowledge, and Pro-environmental Behavior and Participant's Gender and Level of Schooling .....	2672
Conclusion .....	2673
References .....	2674

This chapter was previously published non-open access with exclusive rights reserved by the Publisher. It has been changed retrospectively to open access under a CC BY 4.0 license and the copyright holder is "The Author(s)". For further details, please see the license information at the end of the chapter.

D. M. Nzengya (✉)  
Department of Social Sciences, St Paul's University, Limuru, Kenya  
e-mail: [dmuasya@spu.ac.ke](mailto:dmuasya@spu.ac.ke); [dnzengya@yahoo.com](mailto:dnzengya@yahoo.com)

F. Rutere  
Faculty of Social Sciences, St Paul's University, Limuru, Kenya  
e-mail: [francisrutereone@gmail.com](mailto:francisrutereone@gmail.com)

---

**Abstract**

Degradation of natural resources exacerbates a country's vulnerability to the effects of climate change. IPCC projections suggest that countries within the horn of Africa, which include Kenya, will suffer most from extreme climate change events, particularly more frequent and prolonged droughts. Women and children suffer disproportionately from the consequences of environmental degradation. Public participation is one of the strategies governments pursue to combat environmental degradation; however, there has been limited research to better understand students' environmental attitudes and pro-environmental behavior to better inform student-led participatory designs. Students comprise a significant proportion of the population in Kenya. This research conducted in 2018 at Nginda Ward, Embu County, comprised a survey of 121 students: 58 high school and 63 primary school students. The research investigated students' environmental knowledge, environmental attitudes, and pro-environmental behavior. Qualitative data were analyzed thematically. Multivariate statistics (MANOVA) were used to examine the relationship between the dependent variables and the participant's gender and level of schooling. From the results obtained, the top five most frequently mentioned *local* environmental problems by the students sampled included water pollution, deforestation, air pollution, scarcity of safe sources for water for domestic use, and soil erosion. Inferential statistical results revealed that there is a significant relationship between students' level of schooling and environmental attitudes,  $F = 11.79, (1, 120), p < 0.01$ . In addition, there is a significant relationship between students' level of schooling and environmental knowledge, *that is, perceived severity of environmental problems*,  $F = 5.33, (1, 120), p < 0.05$ . Research findings further revealed a significant relationship between gender and environmental knowledge,  $F = 9.62, (1, 120), p < 0.01$ . However, gender differences in pro-environmental behavior were not statistically significant. Also, differences between primary and high school students' pro-environmental behavior were insignificant.

---

**Keywords**

Environmental degradation · Environmental attitudes · Pro-environmental behavior · Student-led participatory environmental conservation · Primary and high school students · Embu County · Kenya

---

**Introduction**

The sub-Saharan Africa (SSA) region is among the regions of the world experiencing severe environmental degradation and deterioration. Environmental degradation exacerbates the region's vulnerability to the effects of climate change. IPCC projections suggest the SSA particularly countries within the horn of Africa are most the parts of the world that will suffer most from extreme climate change events,

particularly more frequent and prolonged droughts (IPCC 2014). While forest cover has improved remarkably in industrialized nations, the majority of the developing nations experienced severe deforestation during the last two decades. Other pervasive environmental problems in the SSA include species depletion and extinction, poor solid waste disposal, overpopulation, wide-spread soil erosion, desertification, and wide-spread pollution of surface water resources. There are many direct and indirect drivers of environmental degradation and changes in the SSA. These include rapid urbanization, overexploitation of land resources, wide-spread invasive alien terrestrial and aquatic alien species, and climate change.

There are many push-pull factors that drive urbanization in the SSA. This includes rural-urban migration driven by a mix of factors. The productivity of small-scale agriculture which was the main economic mainstay for majority of SSA residents have been declining dramatically due to poor land-husbandry practices, climate change, and environmental degradation forcing people to opt for urban life to pursue alternative economic opportunities (MEA 2005). Because of poor urban planning, pervasive urban poverty, and poor governance, urbanization in most of SSA towns and cities takes the form of proliferation of crowded informal settlements. With poor solid waste management practices and limited or lack of sewerage, most urban wastewater, stormwater runoff ends in rivers and lakes untreated or partially treated, further polluting the region's dwindling surface water resources. Rising population further drives demands for firewood for cooking, the basic energy sources for cooking for the majority of the region's rising rural population. Deforestation in the SSA has been attributed to rising demands for farmlands, rising demand for grazing land, timber, as well as places for settlement.

Environmental degradation poses a threat to efforts by governments and donor agencies towards achieving many of the SDGs by 2030. Deforestation, for instance, worsens the scarcity of firewood, increasing the time women and girl children spent in the search of the commodity. The scarcity of water, firewood, and food is reducing time for productive work among women who are generally breadwinners among the families in the region. The loss of biodiversity threatens domestic and foreign tourism which employs thousands, further threatening the socioeconomic development and livelihood of millions (Shandra et al. 2008). Rising population drives increasing demands for fodder and fuel (MEA 2005). Arid and semiarid areas (ASALs) comprise a significant proportion of land for many of the countries with the SSA region. Thus, desertification has risen during the last decade as shortages of land forced millions of people to migrate to these ecologically fragile areas for settlement and cultivation. Consequently, desertification sets in due to over-cultivation and deforestation pose threats to biodiversity and livelihood of millions of people living in drylands. Extreme droughts associated with extreme climate change events have become commonplace in the ASALs in Kenya leading to massive livestock losses.

In Embu County, drivers of environmental degradation include the Kathangariri Tea Factory located in Nginda ward. According to some reports, the tea factory is estimated to consume 1,200,000 m<sup>3</sup> of wood fuel to process tea leaves per year. This fuelwood is purchased from the local community. Because many of the rural



residents are poor, the majority are involved in the sale of firewood and charcoal for livelihoods. Rising trends in urban centers and towns in Embu County have further accelerated the use of wood since they use charcoals and wood fuel for cooking. It is estimated that biomass usage accounts for over 92.2% of energy sources in Embu County. All these degradations remain pervasive despite efforts by the national environmental management authority to educate people on the need to conserve the environment. A multi-institutional approach is necessary to combat environmental degradation. Young people comprise an important constituent in the fight against the degradation of natural resources; thus, understanding youth attitude, perception, and conservation behavior is crucial for current and future generation.

Kenya is among the world nations facing severe environmental degradation posing a huge threat to Kenya's socioeconomic development and growth. For instance, human encroachment in the country's water catchments, among them the Mau water catchment, has been blamed for the drying of springs and streams that feed river Mara. On the other hand, Mara River that waters the park is drastically reducing threatening livelihood in the park (Mango et al. 2011). Women and children suffer disproportionately from the consequences of environmental degradation. There has been a rise in efforts to mainstream environmental education. The number of nongovernmental organizations working to address environmental degradation has risen significantly over the last 10 years. Public participation is envisaged as a core strategy for combating environmental degradation; however, there has been limited research to better understand students' environmental attitudes and pro-environmental to better inform participatory environmental conservation models. Students comprise a significant proportion of the population in Kenya. The goal of this study was to primary and high school students' environmental knowledge, attitudes, and pro-environmental behavior.

---

## Literature Review

### Concept of Environmental Attitudes and Pro-environmental Behavior

Ajzen and Fishbein (1980) have attempted to provide theoretical explanations on the links between environmental attitudes and pro-environmental behavior. The researchers provided ways to overcome the challenges encountered by measuring attitude and behavior, which posed challenges to previous scholars. According to Ajzen and Fishbein, for one to measure the relationship between behavior and attitude, he/she must measure attitude toward a specific behavior. According to the authors, human beings adapt behavioral practices based upon the available information and not necessarily by unconscious drive or influential desires. Behavior is not determined by attitude directly, but rather attitude influences behavioral intention which leads to actions. Actions are influenced not only by attitude but also by social pressure. Behavioral outcomes are shaped or mediated by normative beliefs (Ajzen and Fishbein 1980).

This theory by Ajzen and Fishbein (1980) has been used in the analysis and explanation of factors leading to pro-environmental behavior. According to this theory, selfish competitive oriented people are less likely to behave proactively on environmental issues. Therefore, it is unlikely that selfish competitive integrated people consider environmental stewardship in their day-to-day decisions but rather are driven by greed to exploit resources for their gain. Thus, this theory sheds light on how to understand the pro-environmental behavior of different social groups within society.

## Empirical Review

Several authors have argued that environmental degradation is a human behavior problem. Siefer et al. (2015) works on human-environment system knowledge framework attempted to demonstrate a correlation between attitudes and pro-environmental behavior among adults and graduate students in Chile. The authors posited that more knowledge of the environment translates to more awareness of problems associated with environmental degradation and thus change of attitude and pro-environmental behavior. The researchers discovered that the more aware individual was on global environmental problems created guilty upon him or her thus changing the behavior toward conservation. The authors also reported that environmental knowledge is the level of a personal feeling that his or her actions have led to degradation thus enhancing pro-conservation behavior. The authors did not find significant correlations between an individual's income and pro-environmental behavior, despite income level enhancing the individual's formal educational attainment.

Mifsud (2011) has examined the relationship between environmental knowledge, attitudes, and behavior, among Maltese Youth. The authors' findings suggested that Maltese Youth had enough global environmental knowledge but very little of the local environmental situation. This was found to harbor their change of behavior toward the local environment that was under degradation. Mifsud (2011) found that the use of radio, television, journal, and new paper was limited which could have portrayed the environmental situation on Maltese thus creating pro-environmental behavior. The authors' findings suggested that environmental knowledge enhances pro-environmental behavior.

There are several reasons why students may be more knowledgeable about the global environment than about the local environment. Mifsud (2011) attributed the predicament to the lack of textbooks on the Maltese environment. This situation may be exacerbated by market demands and forces that force book writers to publish books that sell, especially where there is a limited market for books, as is the case in Malta. The study further revealed the important interplay between media, family and friends, and local context and knowledge in influencing students' attitudes and pro-environmental behavior.

Measurement of environmentally relevant attitude and behavior is important for serious evaluation of environmental education programs. The clear environmental education program will only spring from proper measurement instruments that will

take care of believing, attitude, values, and world view. This may depend on the pool of instruments used ranging from attitude measure, preservation, and utilization. It will allow persons to endorse environment protection and usage of natural resources. However, the author used one order; lack of measurement corresponding instrument will reduce attitude behavior consistency, which means the behavior is measured at a given level. On the other hand, the ecological situation at a given time will reduce attitude, making behavior measure either too easy or difficult. The socioeconomic status of parents was not measured; thus, little is known whether a household's socioeconomic status affects the social desirability of the youth.

Several other researchers have reported a relationship between education level and environmental attitude. According to Ugulu et al. (2013), pro-environmental behavior is influenced by many factors which include and not limited to norms, values, culture, education levels, gender customs, prevailing circumstances, and personal beliefs. Various theories that had been put forward to indicate how environmental attitude and pro-environmental attitude is influenced were put into consideration. The researchers reported gaps in the development of data collection tools to collect environmental attitudes and pro-environmental behavior data. The researcher found that female attitudes are higher than those of males, while the female student had a higher positive attitude than males (Gaye et al. 2005).

Environmental education is one way a country can prepare its youth to be responsible citizens of the environment. This will equip students to comprehend information on environmental issues; the more youth have a positive influence on conservation behavior. This is likely to enhance the required participation by students in environmental conservation and hence the positive behavioral change. Ugulu et al. (2013) has pointed out that science subjects tend to inspire desire and enlightenment amongst youth about environmental problems and knowledge on solving these problems. Ugulu et al. (2013) further argued that when youth lack knowledge on environmental issues, there is a corresponding lack of environmental stewardship. Education, therefore, seems to shape a critical positive conservation-related attitude and ecosystem conservation. Johnson-Pynn and Johnson (2010) have further examined explored environmental education among the East African Youth. The authors discovered that young people were aware of the many threats to local people and ecosystems in Tanzania and Uganda. A related study by Kioko and Kiringe (2010) on effects of education level on change of attitude and conservational behavior among Maasai Youth of Loitokitok District of southern Kenya reported that educational attainment influenced young people's actions toward the environment. The authors further reported that the gender of individuals influenced attitude toward conservation of environment and wildlife. To them, more males than females felt that wildlife and the environment should be conserved.

The level of schooling was found to enhance environmental knowledge and attitude toward wildlife and environmental conservation. Results from comparisons among formally educated youth and informally educated *moran* indicated statistical differences. High school students were higher than lower primary, while lower primary had higher attitudes than informally educated *moran*. Further, environmental clubs and visiting protected areas enhanced more coverage of wildlife and environmental topics.

The level of schooling enhanced the scope of understanding. On the other hand, the economic benefit increased levels of conservation because moran who benefited from tourism money had no problems with elephants using private land, while those who rely on crops had problems because of damage caused by elephants on their crop, and they had problems with them using private land. On the other hand, children whose parents were working in wildlife conservation had higher knowledge, awareness, and attitude than those whose parents were not working. Those who benefit from bursaries were for the idea that elephants should be protected. Females generally had a low attitude on conservation wildlife conservation because they associated the animals with danger. However, females showed more environmental concern than males. Based on the results of this study, the most prevalent method of practically engaging the Youth in environmental education appears to be participation in wildlife club activities. While all the schools had clubs, lack of funds limited club activities to gardening and tree planting within the school. Nevertheless, the clubs played an important role in environmental education. Membership increased the likelihood of students visiting protected areas such as Amboseli. However, Kioko and Kiringe's work (Kioko and Kiringe (2010) focused on the influence of the benefit of the conservation of wildlife on environmental education.

---

## Materials and Methods

The research used a survey design to collect and analyze both qualitative and quantitative data. The sample constituted 121 primary and high school students. The researchers administered the surveys face to face with the help of teachers. All the responses were filled by the researcher according to the participants' answers. Additional data collected included the gender of the participant and also whether or not a participant had visited any conservation area.

Measurement variables are environmental attitudes, environmental knowledge and pro-environmental behavior. Students' environmental attitude was measured according to the level of agreement or disagreement on (9) statements from New Environmental Paradigm (NEP) scale (Dunlap 2000). Participants were required to rate their level of agreement/disagreement with each statement based on a scale of 5 = *strongly agree* to 1 = *strongly disagree* (overall score range, 9–45). The Cronbach's alpha value for the nine statements was 0.63. A high score means an individual had a higher agreement on items related to a particular statement. Students' environmental knowledge was measured using nine statements. Participants were required to rate their environmental knowledge according to a scale of 5 = *completely agree* to 1 = *completely disagree*. The Cronbach's alpha value for the nine statements were 0.72; a high score means a particular problem was perceived to be serious. Student's pro-environmental behavior (*self-reported willingness to support potential/actual government's pro-environmental environmental conservation policies*) was measured using response to nine statements posed on willingness to support current or potential government conservation policies, based on a scale of 5 = *completely willing* to 1 = *not willing at all*. Cronbach's alpha for nine statements was 0.73.

Finally, students' participant pro-environmental behavior (*self-reported willingness to participate in community-organized conservation activities*) further measured using the response of nine statements posed on willingness to support community conservation activities, based on a scale of 5 = *completely willing* to 1 = *not willing at all*. The Cronbach's alpha value for the nine statements was 0.82.

Qualitative data were content analyzed and summarized the most frequently mentioned environmental problems by both primary and high school students. Quantitative data was analyzed using cross-tabulations to examine responses by primary and high school students. Inferential statistics, one-way MANOVA, was used to examine the relationship between environmental attitudes, environmental knowledge, and pro-environmental behavior and participant gender and schooling category.

---

## Results and Discussion

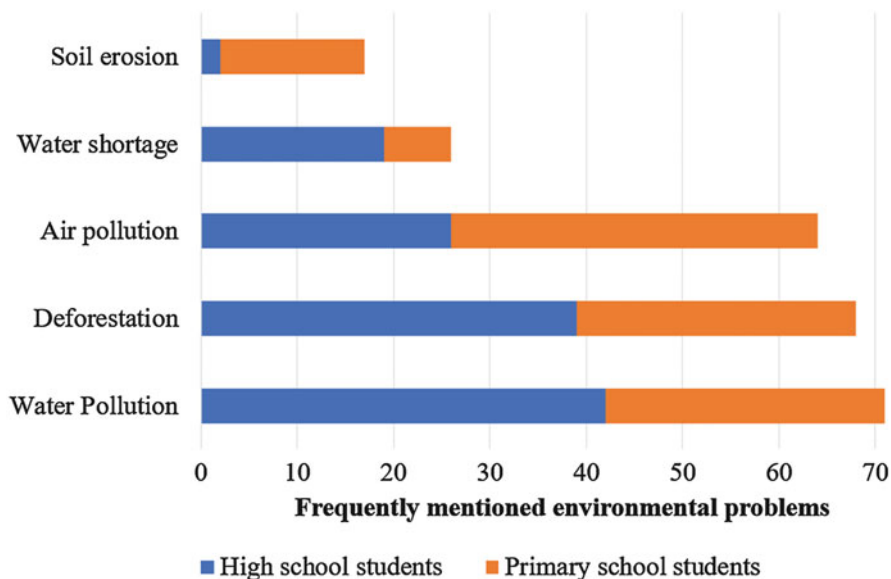
### Perceived Prevalent Environmental Problems

Study participants were asked to list what they perceived as the top three environmental problems in the local area. The lists of mentioned problems were entered in an Excel spreadsheet, and a tally was done to summarize the top five frequently mentioned environmental problems. Results obtained showed that the top five frequently mentioned environmental problems, in order of the most to least frequently mentioned problems included water pollution, deforestation, air pollution, scarcity of water, and soil erosion. Figure 1 summarizes the frequency of mention of the different environmental problems by category of the respondent (primary versus secondary). Water pollution was more frequently mentioned as a problem by the majority of high school students. Also, more high school than primary students perceived deforestation to be a priority environmental problem in the local area. Surprisingly, however, more primary than high school students perceived air pollution to be an environmental problem of concern. Also, more primary than high school students perceived soil erosion to be an environmental problem prevalent in the local area. However, water shortage was mostly mentioned many times by high school students compared to the number of times the same was mentioned by primary school students.

The pattern for different perceptions of prevalent environmental problems in the area is unclear. Deforestation is, however, a prevalent problem in the study area, and also the media in Kenya has sustained a campaign about deforestation as a priority environmental problem. Both student's daily experiences and also media publicity may explain the high mention of deforestation as a priority environmental problem.

### Students Environmental Attitudes (NEP Questions)

Table 1 summarizes students' environmental attitudes according to the nine (NEP) statements posed. The majority of high school students (85%), compared to 63% of



**Fig. 1** Top five frequently mentioned environmental problems (N = 121). (Source: Survey data 2018)

the primary students sampled, were strongly agreeable that the Earth has plenty of adequate natural resources if we just learn to develop them. The majority of the high school students (60%), compared to 58% of the sampled primary school students, were agreeable that “despite our special ability, humans are still subject to the law of nature.” Most primary school students (59%), compared to 51% of the sampled high school students, were agreeable that with the statement that “plants and animals have as much right as humans to exist.” Close to 60% of the high school students, compared to 46% of the primary school students sampled, were agreeable with the statement that “if things continue as they are present, we will soon experience a major environmental catastrophe.” Only 14% of the high school students compared to 14% of the primary school students sampled were agreeable that “the Earth is like a spaceship with very limited room.” Only 39% of the high school students sampled compared to 25% of the primary school students were agreeable with the statement that “we are approaching the limit of the number of people the Earth can support.”

**Environmental Knowledge: Perceived Seriousness of the Environmental Problems**

Table 2 summarizes students’ ratings related to the level of agreement/disagreement on the nine statements concerning the perceived seriousness of environmental problems. The majority of primary school students (66%) and 55% of high school students perceived that deforestation was a serious problem in the locality.

**Table 1** Environmental attitudes of primary and high school students (NEP questions) (N = 121)

	Category	Strongly agree (%)	Somewhat agree (%)	Unsure (%)	Somewhat disagree (%)	Strongly disagree (%)
We are approaching the limit of the number of people the Earth can support	High school	39	12	3	29	17
	Primary school	25	4	9	27	36
When humans interfere with nature, it often produces disastrous	High school	55	20	6	10	8
	Primary school	38	7	11	7	38
Humans are seriously abusing the environment	High school	59	20	6	2	14
	Primary school	46	9	2	5	38
The Earth has plenty of natural resources if we just learn to develop them	High school	85	8	2	5	2
	Primary school	63	20	4	2	13
Plant and animals have as much as a human right to exist	High school	51	23	5	6	15
	Primary school	59	13	9	4	16
Despite our special abilities, humans are still subject to the law of nature	High school	60	28	6	2	5
	Primary school	59	13	9	7	13
The Earth is like a spaceship with very limited room	High school	43	11	8	20	36
	Primary school	14	7	7	14	57
The balance of nature is very delicate and easily upset	High school	28	29	12	12	19
	Primary school	25	9	2	13	52
If things continue on their present, we will soon experience a major environmental catastrophe	High school	59	22	3	8	9.2
	Primary school	54	4	9	5	29

Source: Survey Data 2018

**Table 2** Students' environmental knowledge: *perceived seriousness of environmental problems* (N = 121)

		Completely agree (%)	Partly agree (%)	Unsure (%)	Partly disagree (%)	Completely disagree (%)
Deforestation is a serious problem in our local area	High school	55	5	5	11	17
	Primary school	66	5	4	4	21
Soil erosion is a serious problem in our local area	High school	46	9	2	6	37
	Primary school	59	5	11	5	20
Pollution of streams and rivers is a serious problem in our local area	High school	48	9	8	9	26
	Primary school	61	7	13	4	16
Pollution of water springs is a serious problem in our local area	High school	35	12	8	8	37
	Primary school	59	8	4	2	29
Cutting trees to burn charcoal is a serious problem in our local area	High school	45	12	9	14	20
	Primary school	62	5	4	2	27
Siltation of streams and small dams (meaning streams and small dams are filling up with sand due to soil erosion) is a serious problem our local area	High school	34	15	3	15	32
	Primary school	50	5	4	7	34
Degradation of swamps and marches is a serious problem in our local area	High school	40	11	8	12	29
	Primary school	45	9	13	14	20
Spreading of towns and cities over more and more rural land is a serious problem in our local area	High school	43	2	3	11	31
	Primary school	41	11	5	9	34
Degradation of local stream and rivers due to sand harvesting is a serious problem in our local area	High school	42	11	8	8	32
	Primary school	21	11	14	9	45

Source: Survey data 2018



According to Kamweti (2009), Kenya is among the countries in Africa with the highest loss of vegetation cover, with 90% of the country's indigenous forests having been lost. Drivers of deforestation in Nginda Ward include Kathangariri Tea Factory which consumes an estimated 1,200,000 m<sup>3</sup> of wood fuel to process tea leaves per year.

60% of the high school students, compared to 48% of the primary school students, completely agree that pollution of streams and rivers is a serious problem in locality.

Majority of primary school students (59%) compared to 46% of high school students sampled agreed that soil erosion is a serious problem in locality. The findings are very consistent with the previous statement because where there is deforestation, soil erosion is becoming a prevalent phenomenon.

Half of the primary school students (50.0%), compared to 34% of high school students, completely agreed that siltation of streams and small dams is a serious problem in locality. Streams are very visible in the area being on the slopes of Mount Kenya. The coloration of the water, especially during the rainy season, was very visible.

Less than half of the high school students' (43%), compared to 41% of the primary school sampled, completely agreed that the spreading of towns and cities over more and more rural land is a serious problem in the locality. This perception may be probably a result students' awareness of the current trends of the rapid spread and growth of towns and urban centers in Embu County.

Less than half of the primary school students (45%), compared to 41% of high school students sampled, completely disagree that the degradation of local streams and rivers due to sand harvesting is a serious problem at the locality. Previous studies (Mango et al. 2011) have suggested a disconnect in which students were aware of global environmental problems confronting humanity today but not local issues. This is probably a manifestation of this problem at the study site.

### **Pro-environmental Behavior: Self-Reported Willingness to Support the Government's Pro-environmental Conservation Policies**

Table 3 summarizes students' pro-environmental behavior measured according to respondent's self-reported willingness to support the government's environmental conservation policies on the nine statements posed.

#### **Willingness to Support a Government's Ban on the Use of Plastic Bags**

Plastic packaging of goods at shopping malls is a huge source of solid waste generation in cities and towns. In 2017, the Kenya government enforced a ban on plastic packaging. Participants were asked about their willingness to support the government ban on plastic packaging. Results showed that 84% of the primary school students were willing to support government ban compared to 66% of high school students.

**Table 3** Pro-environmental behavior: *students' self-reported willingness to support potential government conservation pro-environmental policy* (N = 121)

	Category	Completely willing (%)	Partly willing (%)	Neither willing nor unwilling (%)	Not willing (%)	Completely unwilling (%)
Willingness to support a government's ban forbidding the use of plastic bags	High school	66	11	3	5	1
	Primary school	84	0	2	9	5
Willingness to support a government's ban forbidding cutting trees for charcoal	High school	57	23	2	6	12
	Primary school	43	4	5	9	4
Willingness to support a government's policy requiring factories and industries that pollute streams and rivers pay charge toward cleaning our rivers and streams	High school	72	8	8	8	5
	Primary school	74	7	9	2	9
Willingness to support a government's policy to cancel the licenses of factories and industries that pollute streams and rivers	High school	43	20	0	15	22
	Primary school	60	9	9	5	16
Willingness to carry eco-friendly bags during shopping	High school	57	14	3	8	16
	Primary school	70	13	2	4	13
Willingness to support a government's policy to charge people who wash their	High school	37	31	8	8	17
	Primary school	64	7	5	2	2

(continued)

**Table 3** (continued)

	Category	Completely willing (%)	Partly willing (%)	Neither willing nor unwilling (%)	Not willing (%)	Completely unwilling (%)
clothes in streams						
Willingness to support a government's policy to charge people who wash vehicles in streams/rivers	High school	48	28	5	3	17
	Primary school	63	5	5	4	23
Willingness to support a government's policy to charge people who pump water from rivers for irrigation without permits	High school	48	28	5	3	17
	Primary school	67	13	4	4	20
Willingness to support a government's policy to charge construction companies who obtain huge amounts of water for construction from streams without permits	High school	48	12	9	11	20
	Primary school	61	13	4	4	20

Source: Survey data (2018)

### **Willingness to Support a Government's Ban Forbidding Cutting Trees for Charcoal**

Kenya has a policy that regulates charcoal burning. According to this policy, selling charcoal without a permit is prohibited. Although there are policies that require charcoal burning to obtain permits, this regulation is rarely enforced because the government lacks sufficient policing resources. Also, corruption in Kenya is pervasive further undermining the regulation of illegal charcoal burning. Participants were there asked if they were completely willing or unwilling to carry eco-friendly bags during their shopping. Results showed 57% of the high

school students were completely willing to support the regulation compared to 43% of the primary school pupil.

### **Willingness to Support County Government's Policy Requiring Factories and Industries That Pollute Streams and Rivers Pay Charge Toward Cleaning Our Rivers and Streams**

Kenya has a policy that regulates the quality of wastewater discharge into surface water bodies, streams, rivers, and lakes (GoK 2013). Polluter pay principle requires factories and other people caught discharging wastewater and other effluents in water sources to pay for the consequent cleaning. Participants were asked if they were willing to support county government's policy requiring factories and industries that pollute streams and rivers pay charge toward cleaning our rivers and streams. Results showed that 74% of primary school students and 72% of the high school students sampled were completely willing to support this hypothetical pro-environmental government policy.

### **Willingness to Support a Government Policy to Cancel the Licenses of Factories and Industries that Pollute Streams and Rivers**

Factories and other industries are major sources of point sources of water pollution. Kenya has a policy that regulations point sources related sources of water pollution. Participants were there asked if they were completely willing or unwilling to carry eco-friendly bags during their shopping. Results showed that 61% of the primary school students were completely willing to support compared to 43% of the high school students. It is however not clear why a low percent of high school students showed willingness to support a government policy mentioned. Pollution of rivers and lakes by factories benefits only a few individuals by way of cutting costs of wastewater treatment, yet the majority of the citizens pay for those consequences in terms of illnesses.

### **Willing to Carry Eco-Friendly Bags During Shopping**

The provision of packaging materials to customers in shopping malls is a huge source of solid waste generation. One method in reducing solid waste related to packaging provided by shopping malls is to provide incentives where people carry their eco-friendly bags when they go shopping. Participants were there asked if they were completely willing or unwilling to carry eco-friendly bags during their shopping. Results showed that 70% of the students were completely willing to carry eco-friendly bags during shopping, compared to 57% of the high school students.

### **Willingness to Support a Government Policy to Charge People Who Wash Clothes in Streams**

Washing clothes in rivers and streams and lakes is a common practice in many rural settings in Kenya. Many forms of detergents used for laundry have high levels of phosphates and other chemicals that pollute water and potentially trigger local eutrophication problems in water sources. Participants were there asked about their willingness to support or not to support a hypothesized scenario in which county

government enforced charges for people who wash clothes in streams in one measure to curb pollution associated with this practice. Results showed that 64% of the primary school students were completely willing to support the policy compared to 37% of the high school students. It's unclear why high school students would express low support toward a government policy that provides charges for people who wash their clothes in streams. Washing clothes in rivers and lakes contribute to localized eutrophication problems, undermining the quality of drinking water sources.

### **Willingness to Support a Government Policy to Charge People Who Wash Vehicles in Streams/Rivers**

Washing vehicles in rivers and streams and lakes is a common practice in many rural settings in Kenya. Many forms of detergents used for laundry have high levels of phosphates and other chemicals that pollute water and potentially trigger local eutrophication problems in water sources. Participants were there asked about their willingness to support or not to support a hypothesized scenario in which county government enforced charges for people who wash clothes in streams in one measure to curb pollution associated with this practice. Results showed that 63% of the primary school pupil were completely willing to support the policy compared to just 48% of the high school students.

### **Willingness to Support a Government Policy to Charge People Who Pump Water from Rivers for Irrigation Without Permits**

The abstraction of water from streams, rivers, swamps, and lakes to irrigate farm crops is a common practice. Although there are policies that require people irrigating crops to obtain water abstraction permits, this regulation is rarely enforced because the government lacks sufficient policing resources. Also, corruption in Kenya is pervasive further undermining the regulation of illegal abstraction of water from streams, rivers, lakes, and swamps for private irrigation gains. Participants were asked about their willingness to support or not to support a hypothesized scenario in which county governments enforced charges to all people found abstracting water for irrigation without permits. Results showed that 68% of the primary school students were willing to completely support compared to just 48% of the high school students.

### **Willingness to Support Policy to Charge Construction Companies Who Obtain Huge Amounts of Water for Construction from Streams Without Permits**

Rapid urbanization has been a major source of extraction of water from both underground and surface resources. In many countries, the abstraction of huge amounts of water from streams and rivers competes with other forms of water uses such as water for livestock, small scale irrigation, and also domestic use. Even though governments may have policies that regulate regulate water abstraction, these bad practices might continue because governments lack sufficient resources to enforce compliance. Participants were asked about their willingness to support or not to support a hypothesized scenario in which county governments were to begin

requiring construction companies to pay for the water they collect from streams, rivers, and boreholes. Results showed that 68% of the primary school students were completely willing to support compared to just (48%) of the high school students.

### **Pro-environmental Behavior: Students' Self-Reported Willingness to Participate in Community-Organized Environmental Conservation Activities**

Table 4 summarizes results of students' pro-environmental behavior measured according to respondent's self-reported willingness to participate in the community-organized environmental conservation activities.

Majority of the primary school students, 80%, and 74% of high school students were willing to voluntarily participate if their communities organized to clean local water streams. Most primary school students (84%) and high school students (79%) were willing to volunteer in garbage collection activities to keep their neighborhood clean. The level of response indicates and probably suggests interests for better environmental hygiene.

Majority of the high school and primary school students (75%) expressed willingness to donate some seedlings to their neighbors if they needed to plant some trees in their yards/fields. Majority (80%) of the high school and 75% of primary school students were completely willing to voluntarily participate in tree planting activities in their neighborhoods. The high-percent willingness probably suggests students' perception of the need for action to combat deforestation in their own locality. The majority of the primary school students (84%) were willing to donate some seedlings to a public primary school near where they live to plant at the school if they had tree nursery. This was an indication of conservation behavior because tree seedling is sold for monetary gain, but these respondents were selflessly willing to donate. Social studies they learn in school may also have played a major role in shaping their thought-form.

The survey also revealed that 77% of the high school students were also willing to donate some seedling to primary school. Majority (83%) of primary school students and 80% of the primary school students were willing to attend the meeting organized to discuss solutions to the environmental problem affecting their community. The impact of environmental degradation affects everyone in the ward. However, more so women and children are affected more than others because of house chores like looking for firewood and fetching water. Gill and Kewlani (2010) have reported that as the problems of deforestation worsened in India, there was a corresponding increase in the amount of time that women spent looking for firewood. Deforestation further reduced working hours in the agricultural fields thus aggravating poverty and hunger within these communities in India.

Natural environment enhances psychological satisfaction, a key ingredient for healthy lives (Bermudez et al. 2015). On the other hand, environmental degradation, particularly deforestation, can trigger the removal of the girl child from school to assist in these home activities to help in search for the scarce firewood. This can lead

**Table 4** Pro-environmental behavior: *self-reported willingness to participate in community-organized environmental conservation activities* (N = 121)

	Category	Completely willing (%)	Partly willing (%)	Neither willing nor unwilling (%)	Not willing (%)	Completely unwilling (%)
Willingness to volunteer to participate in a community organized to clean water streams near the place I stay	High school	74	6	11	0	9
	Primary school	80	14	2	0	4
Willingness to volunteer in a garbage collection activity to keep neighborhood clean	High school	79	11	5	3	3
	Primary school	84	11	2	0	4
Willingness to donate some seedlings to neighbors if they need to plant some trees in their yards/fields	High school	75	9	3	5	0
	Primary school	75	14	5	5	0
Willingness to donate some seedlings to a public primary school near where I live to plant at the school	High school	77	9	5	5	5
	Primary school	84	9	4	0	4
Willingness to volunteer to participate in a tree planting activity in my neighborhood	High school	80	6	8	3	3
	Primary school	75	9	5	22	9
Willingness to meetings organized to discuss solutions to environmental problems	High school	80	14	3	0	3
	Primary school	83	7	5	5	0

(continued)

**Table 4** (continued)

	Category	Completely willing (%)	Partly willing (%)	Neither willing nor unwilling (%)	Not willing (%)	Completely unwilling (%)
affecting my community						
Willingness to donate money toward youth environmental conservation activities such as wildlife clubs in schools	High school	59	23	8	5	6
	Primary school	55	23	5	9	7
Willingness to participate in community soil conservation activity in my neighborhood	High school	72	11	11	3	3
	Primary school	64	16	9	5	5
Willingness to donate money toward rural women groups involved in establishing tree nurseries	High school	63	14	5	8	11
	Primary school	84	5	4	4	4

Source: Survey data (2018)

to problems of gender parity in both high school and primary school enrollment. This can consequently perpetuate gender inequality in which women are unable to compete for jobs in the job market. Studies have shown that school wildlife and health clubs have positive environmental attitudes and pro-environmental behavior (Ajiboye and Silo 2008). Participants were asked to rank their willingness to donate money toward youth environmental conservation activities such as wildlife clubs in school. Results showed that barely over half of the high school students (59%) and 55% from primary were willing to donate money toward youth environmental conservation activities such as wildlife clubs in school.

Most soil conservation activities in rural areas rely on social capital for man power in undertaking various soil conservation activities. Social mobilization can take the form of men-to-men, women-to-women, but also youth mobilizing to dig trenches and holes among other soil conservation activities. Participants were asked to rank their willingness to participate in community soil conservation activities in my neighborhood. Majority (72%) of the high school and 64% of the primary school students were completely willing to voluntarily participate in soil conservation activities in their neighborhood. On the other hand, water was severely polluted by



runoff during the rainy season. During recent years, there have been increasingly more rural women groups involved with raising tree nurseries both as a source of income and as alternative sources of seedlings to plant in their farms. Participants were asked to rank the willingness to support rural women groups involved in establishing tree nurseries. Results obtained showed the majority (84%) of the primary school students and 63% from primary were willing to donate money toward rural women groups involved in establishing tree nurseries. Primary school students also appear to have understood the importance of trees.

### **Relationship Between Environmental Attitudes, Environmental Knowledge, and Pro-environmental Behavior and Participant's Gender and Level of Schooling**

A two-factor MANOVA was conducted to examine the relationship between environmental attitudes, environmental knowledge, and pro-environmental behavior and participant's gender and level of schooling. The dependent variables in the model were composite scores of environmental attitudes; environmental knowledge; and pro-environmental behavior-1 "participant's self-reported willingness to support potential a government pro-environmental policy" and pro-environmental behavior-2 "participant's self-reported willingness to participate in community-organized environmental conservation activities."

Results obtained revealed that there is a significant relationship between students' level of schooling and environmental attitudes,  $F = 11.79$ , (1, 120),  $p < 0.01$  (mean for high school students = 3.78,  $SD = 0.57$ ; mean for primary school students = 3.31,  $SD = 0.90$ ). In addition, there is a significant relationship between students' level of schooling and environmental knowledge,  $F = 5.33$ , (1, 120),  $p < 0.05$  (mean for high school students = 2.83,  $SD = 0.96$ ; mean for primary school students = 2.43,  $SD = 0.92$ ). These findings are consistent with those from previous research.

Research findings revealed a significant relationship between gender and environmental knowledge, *that is, perceived severity of environmental problems*,  $F = 9.62$ , (1, 120),  $p < 0.01$  (mean for girls = 2.91,  $SD = 0.97$ ; mean for boys = 2.39,  $SD = 0.88$ ). However, gender differences and, also, differences between primary and high school students' pro-environmental behavior were insignificant. Also, none of the interaction effects was statistically significant.

### **Lessons Learned, Study Limitations, and Recommendations for Future Research**

Four of the most prevalent environmental problems mentioned by the students, namely, water pollution, deforestation, scarcity of water, and soil erosion, are consistent with the literature on prevalent problems confronting Kenya's rural citizens. It is unclear what informed student's mention of air pollution, among the list of top environmental problems. This is probably informed by literacy gained from classes on prevalent environmental problems globally. Compared to water pollution, Kenya has had considerable media publicity and, also public attention

during *barazas*, on deforestation and soil erosion as key threats to Kenya's environment and livelihoods. It is surprising, however, to find that students ranked water pollution as a top environmental problem.

This research is among the pioneer studies to use the NEP developed by Dunlap (Dunlap 2000). NEP scales have been used largely by researchers in western countries to measure environmental attitudes. Reliability tests revealed 9 out of the 15 NEW statements met the reliability threshold for a composite environmental attitude score. Further studies are needed to further explore the reliability of NEP scales for the measurement of environmental attitudes in Kenya. Measurements scales for environmental knowledge and pro-environmental behavior were adapted from literature. Further studies are needed to validate these scales in different parts of Kenya.

There are several limitations to this study. The target population is comprised of students largely drawn from one ethnic community. This potentially limits generalizations of study findings to different parts of the country. The study sample comprised of high school students were drawn from four, and primary school students were drawn from class seven. This study relied on a survey approach to gather data on self-reported environmental knowledge, environmental attitudes, and pro-environmental behavior. Future research needs to triangulate survey data with other techniques such as participant observation, to further verify correlations among variables. Potential opportunities for participant observations include targeting groups such as members of school health clubs and wildlife/environmental clubs to compare the extent of participation in and volunteerism toward community-organized environmental conservation activities.

This potentially limits generalizations of study findings to different schooling levels. There is, therefore, a need to examine primary versus high school students' environmental attitudes and pro-environmental behavior in other parts of Kenya and compare findings.

The study findings have implications on interventions, particularly by Embu County government and donor agencies working in the county, seeking to mobilize and engage participation by primary and high school students (school health clubs and wildlife/environmental clubs), in initiatives targeted to combat environmental degradation. Also, the country government use these findings to facilitate targeted environmental education to raise students' environmental attitudes and environmental knowledge to enhance conservation behavior.

---

## Conclusion

Female students perceive environmental problems at the locality to be more severe, compared to their male counterparts. Nonetheless, gender differences in pro-environmental behavior are not statistically significant; also, between primary and high school students' pro-environmental behavior are significant. The study findings have implications on interventions by government and donor agencies seeking to mobilize student-led participatory efforts to promote environmental conservation and enhance rural communities' climate change adaptation efforts and resilience.

## References

- Ajiboye JO, Silo N (2008) Enhancing Botswana children's environmental knowledge, attitudes and practices through the school civic clubs. *Int J Environ Sci Educ* 3(3):105–114
- Ajzen I, Fishbein M (1980) *Understanding attitudes and predicting social behavior*. Prentice-Hall, Englewood Cliffs
- Bermudez BC, Santos Branco DK, Trujillo JC, De Lima JE (2015) Deforestation and infant health: evidence from an environmental conservation policy in Brazil (No. 1008-2016-80406)
- Dunlap R (2000) Measuring endorsement of the new ecological paradigm: a revised NEP scale. *J Soc Issues* 56(3):425–442
- Gaye T, Hamide E, Ceren T, Semra S (2005) Environmental attitudes of young people in Turkey: effects of school type and gender. *Environ Educ Res* 11(2):215–233
- Gill MS, Kewlani J (2010) Deforestation and its impact on women. *Int NGO J* 5(7):171–176
- Government of Kenya (GoK) (2013) *National environmental policy 2013*. Nairobi. Government Printers
- Intergovernmental panel on climate change (IPCC) (2014) *Climate change 2014: mitigation of climate change*. Cambridge University Press, New York
- Johnson-Pynn JS, Johnson LR (2010) Exploring environmental education for East African youth: do program contexts matter? *Children Youth Environ* 20(1):123–151
- Kamweti J (2009) *Causes of deforestation in Africa*. Pauline, Nairobi
- Kioko J, Kiringe JW (2010) Youth knowledge, attitudes and practices in wildlife and environmental conservation in Maasailand, Kenya. *Southern Afr J Environ Educ*, Vol. 27
- Mango LM, Melesse AM, McClain ME, Gann D, Setegn SG (2011) Land use and climate change impacts on the hydrology of the upper Mara River basin, Kenya: results of a modelling study to support better resource management. *Hydrol Earth Syst Sci* 15(7):2245–2258
- Mifsud MC (2011) *An investigation on the environmental knowledge, attitudes and behavior of Maltese Youth*. Online Submission
- Millennium Ecosystem Assessment (2005) *Ecosystem and human well-being*. World Resources Institute, Washington, DC
- Shandra JM, Shandra CL, London B (2008) Women, non-governmental organizations, and deforestation: a cross-national study. *Popul Environ* 30(1-2):48–72
- Siefer D, Neaman A, Salgado E, Juan LC, Siegmars O (2015) *Human-Environment*. In: Smilor RW (ed) *The art and science of entrepreneurship*. Ballinger, Cambridge
- Ugulu I, Sahin M, Baslar S (2013) High school students' environmental attitude: scale development and validation. *Int J Educ Sci* 5(4):415–424

**Open Access** This chapter is licensed under the terms of the Creative Commons Attribution 4.0 International License (<http://creativecommons.org/licenses/by/4.0/>), which permits use, sharing, adaptation, distribution and reproduction in any medium or format, as long as you give appropriate credit to the original author(s) and the source, provide a link to the Creative Commons license and indicate if changes were made.

The images or other third party material in this chapter are included in the chapter's Creative Commons license, unless indicated otherwise in a credit line to the material. If material is not included in the chapter's Creative Commons license and your intended use is not permitted by statutory regulation or exceeds the permitted use, you will need to obtain permission directly from the copyright holder.





# Identifying and Overcoming Barriers to Climate Change Adaptation in the Seychelles

# 130

Daniel Etongo, Vincent Amelie, Angelique Pouponneau, and Walter Leal Filho

## Contents

Introduction: The Vulnerability of Small Island Developing States to Climate Change . . . . .	2676
Climatic and Non-climatic Induced Vulnerabilities in the Seychelles . . . . .	2677
An Overview of Adaptation Measures in the Seychelles . . . . .	2681
Hard Engineering Techniques . . . . .	2681
Soft Engineering Techniques . . . . .	2682
Barriers to Climate Change Adaptation in the Seychelles . . . . .	2686
Options for Overcoming Adaptation Barriers in the Seychelles . . . . .	2688
Conclusions . . . . .	2690
References . . . . .	2690

---

This chapter was previously published non-open access with exclusive rights reserved by the Publisher. It has been changed retrospectively to open access under a CC BY 4.0 license and the copyright holder is “The Author(s)”. For further details, please see the license information at the end of the chapter.

---

D. Etongo (✉)  
James Michel Blue Economy Research Institute, University of Seychelles, Victoria, Seychelles  
e-mail: [Daniel.Etongo@unisey.ac.sc](mailto:Daniel.Etongo@unisey.ac.sc)

V. Amelie  
Seychelles Meteorological Authority (SMA), Mahé, Seychelles  
e-mail: [v.amelie@meteo.gov.sc](mailto:v.amelie@meteo.gov.sc)

A. Pouponneau  
Seychelles’ Conservation and Climate Adaptation Trust (SeyCCAT), Mahé, Seychelles  
e-mail: [ceo@seyccat.org](mailto:ceo@seyccat.org)

W. L. Filho  
Research and Transfer Centre “Sustainable Development and Climate Change Management”  
Hamburg University of Applied Sciences, Hamburg, Germany  
e-mail: [walter.leal2@haw-hamburg.de](mailto:walter.leal2@haw-hamburg.de)

---

**Abstract**

As a Small Island Developing State (SIDS), Seychelles is quite vulnerable to the impacts of climate change, and adaptation is considered a national priority. Despite efforts to enhance its adaptive capacity, a number of barriers still hamper the adaptation process such as fragile institutions and inadequate governance to climate change, financial and human resource capacity constraints, and limited scientific knowledge and understanding of how climate change affects the country. A key barrier to climate change adaptation in the Seychelles is called “remote” or “legacy” barriers – linked to land use decisions made five decades ago during which wetlands were reclaimed for property development. Therefore, 80% of Seychelles’ critical infrastructures are located on the coastline and are exposed to floods, erosion, and sea level rise. Additionally, the pros and cons of hard and soft adaptation interventions in the Seychelles ranging from rock armoring, retaining wall, groynes to ecosystem-based adaptation actions such as timber piling, beach nourishment, dune management, rainwater harvesting, and mangrove and coral restoration are assessed with recommendations on the way forward. In other words, this chapter provides some examples of actions and strategies that may assist the island nations to improve on adaptation actions. An example that addresses partly the financial constrain is the Seychelles’ Conservation and Climate Adaptation Trust (SeyCCAT) that provide funding for medium- and large-scale project in the Seychelles since 2015.

---

**Keywords**

Climate change · Limits to adaptation · Vulnerability · SeyCCAT · Seychelles

---

## **Introduction: The Vulnerability of Small Island Developing States to Climate Change**

Small Island Developing States (SIDS) are generally considered highly vulnerable to climate change, partly because they suffer from similar problems in relation to their landmasses, remoteness, and exposure to natural hazards (Scandurra et al. 2018). As far back as 1992, the United Nations Conference on Environment and Development (UNCED) was the first to recognize SIDS as a distinct group of fragile nations when it stated:

SIDS, and islands supporting small communities are a special case both for environment and development. They are ecologically fragile and vulnerable. Their small size, limited resources, geographic dispersion and isolation from markets, place them at a disadvantage economically and prevent economies of scale. UNCED (1992)

As such, SIDS are generally considered highly vulnerable to climate change as sea level raise, and/or changes in precipitation patterns lead to various negative consequences such as reduction in agriculture yields and damages to infrastructure and to properties (Robinson 2015; Nurse et al. 2014).

For SIDS, the impacts of rising temperatures, sea level rise, variability of rainfall patterns, and more frequent extreme weather events reaffirm the varied climatic and non-climatic vulnerabilities encountered in Island States (IPCC 2018; Robinson 2015). Given that the Indian Ocean is warming at a faster rate than any other tropical ocean region (Roxy et al. 2014), sustainable exploitation of resources within the framework of the Blue Economy will be greatly affected in the absence of proactive adaptation measures. Whereas practitioners and scientists within the adaptation landscape define adaptation differently, we focus on the definition of adaptation as utilized by the Intergovernmental Panel on Climate Change (IPCC), as an “adjustment in natural or human systems in response to actual or expected climatic stimuli or their effects, which moderates harm or exploits beneficial opportunities” (IPCC 2007).

Reducing the vulnerabilities of SIDS and Seychelles in particular is important for the sustainable development of its Blue Economy, livelihoods, human security, and environmental protection. Such actions are both urgent and timely especially at a time when the world is paying attention to the implementation of the Sustainable Development Goals. According to Nurse et al. (2014), SIDS are already experiencing a range of climate-related impacts, including increased coastal flooding and saltwater intrusion. Although its location and landmass sometimes exacerbate its vulnerability to the impacts of climate change, proactive adaptation interventions have been designed, tested, and implemented across SIDS including those of the Indian Ocean Region. These adaptation actions include rock armoring, retaining wall, groynes to ecosystem-based adaptation actions such as timber piling, beach nourishment, dune management, rainwater harvesting, and mangrove and coral restoration (Guillotreau et al. 2012). These adaptation measures are necessary, for instance, for disaster risk reduction (DRR), economic development, as well as terrestrial, coastal, and marine biodiversity conservation especially in this era of the Sustainable Development Goals (Berrang-Ford et al. 2011).

## Climatic and Non-climatic Induced Vulnerabilities in the Seychelles

The Republic of Seychelles, an East African archipelago made up of 115 islands in the Indian Ocean, is one of 58 SIDS around the world. Figure 1 outlines the position of the country. This SIDS suffers from climatic and non-climatic induced vulnerabilities ranging from variability in temperatures and rainfall to anthropogenic driven vulnerabilities that are linked to dependence on climate sensitive livelihoods and economic activities.

**Temperature and rainfall variability:** In the Seychelles, the annual average maximum temperatures between 1989 and 2018 was estimated at 30 °C while the minimum stood at 25 °C (Fig. 2a). Of importance to note is that the overall pattern between the maximum and minimum temperatures during the said period seems to be consistent. However, the diurnal graph (see Fig. 2b) that highlights the differences between the maximum and minimum temperatures shows a decreasing trend. This implies that the minimum temperatures are fast catching up with the maximum temperatures – an indication that the environment is getting warming over the

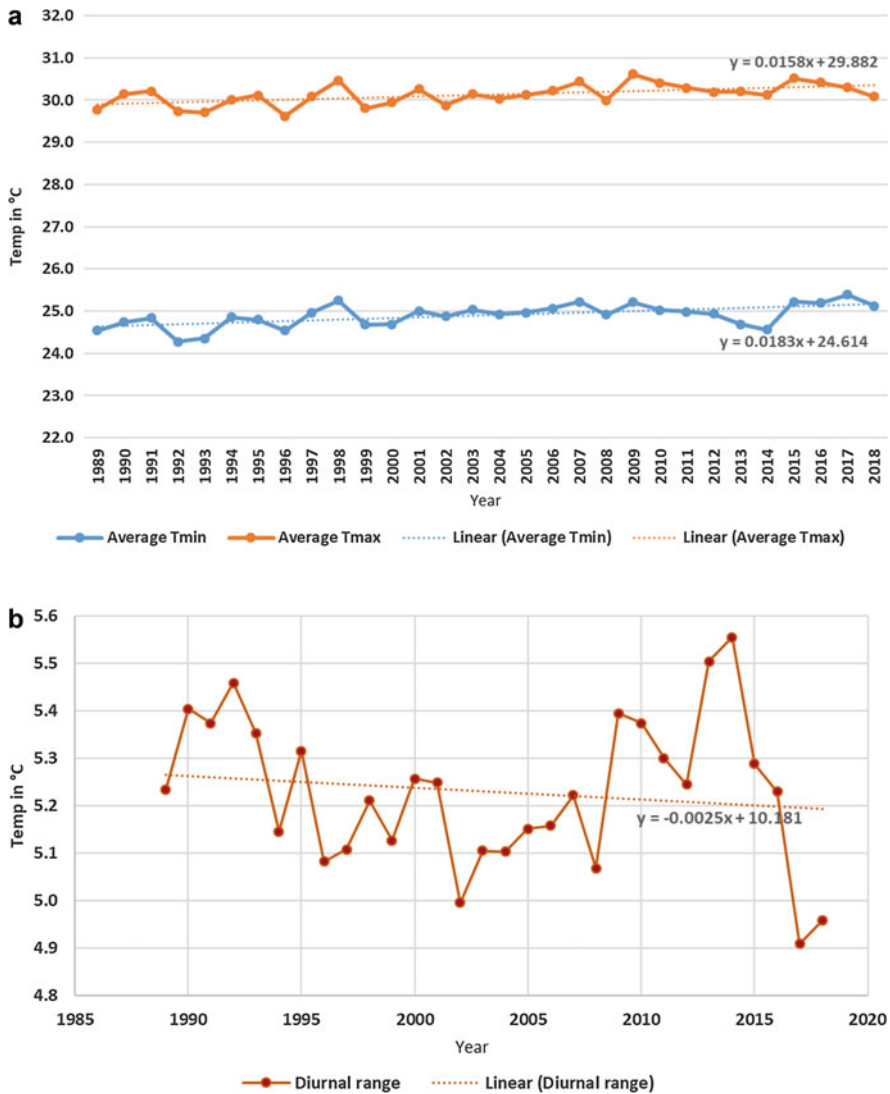


**Fig. 1** Position of the Seychelles within the East African Region. Available online at <https://www.google.com/search?q=map+of+seychelles+and+surrounding+countries>

years. The implication of such a trend in temperature could be linked to the impacts on ecosystem good and services in the Seychelles such as the recurrent coral bleaching events, drought, flash flood, etc.

Furthermore, coral reefs, seagrass meadows, and mangroves in the Seychelles, for example, are supposed to establish a belt of coastal protection and ecosystem services along the shores. However, current manifestation of coastal vulnerabilities in the form of coastal erosion (see Table 1) reinforces the point that these protective ecosystems have been degrading fast. In the Seychelles, coral reefs have been altered over decades following mass mortality events. The most recent coral bleaching event in 2016 has caused coral mortality in the upper 15–20 m in average at least 70% at the Seychelles granite Islands (Wilson et al. 2012). As a result, overall reef growth is declining exposing the coasts of many Seychelles Islands to even more erosion with rising sea levels of the twenty-first century.

**Rainfall patterns:** Annual average figures on rainfall maximum and minimum between 1980 and 2018 in the Seychelles stood at 292 mm and 140 mm respectively (Fig. 3). An interpretation based on Fig. 3 indicate that there have been no major changes over time in terms of annual averages. In other words, the total amount of rainfall, particularly during the rainy seasons compensate for the total amount of less rainfall during the dry season. However, some incident of extreme rainfalls have been recorded in Seychelles with monthly figures equivalent to annual estimates. The most recent of such occurrence was during the last 2 weeks of May 2019 with flash flood that lasted for almost a week in some neighborhoods on Mahé Island (see Etongo 2019). According to same study, flash floods in the Seychelles is linked to



**Fig. 2** (a) Average annual temperatures in the Seychelles between the years 1989 and 2018. (Source Seychelles Meteorological Authority). (b) Diurnal temperature ranges in the Seychelles between the years 1989 and 2018. (Source Seychelles Meteorological Authority)

legacy barriers to adaptation – the reclamation of wetlands for infrastructural development such as housing, resorts, roads, etc. An earlier study conducted in the Seychelles on climate change projection into 2021 indicated that the rainy seasons will be wetter and the dry seasons drier (Government of Seychelles 2009) – a clear manifestation of climate-induced vulnerability as shown in Table 1.

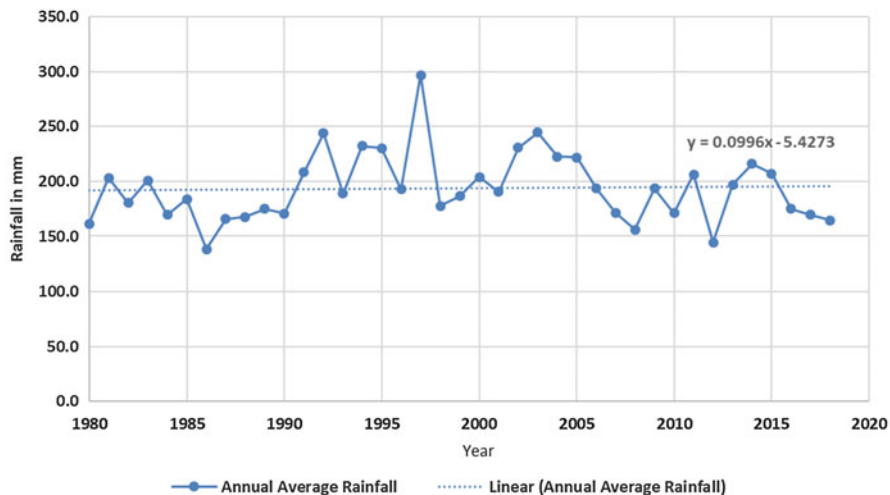


**Table 1** Climatic and non-climatic induced vulnerability in the Seychelles

	Climate or climate-induced vulnerability		Non-climatic induced vulnerability
1	Rainfall, precipitation, runoff	1	Economic, poverty
2	Monsoons, storms, winds	2	Social, cultural
3	Temperature (air and sea surface), heat, humidity	3	Human activities (general), recreational activities
4	Storm surge, coastal inundation, flood	4	Pollution, waste
5	Drought, dry conditions	5	Population growth, demographic changes
6	Sea level rise, tide, wave action	6	Food insecurity
7	Global warming	7	Lack of data/information gaps/awareness
8	Water quality and/or availability, turbidity, siltation, sedimentation	8	Agricultural activities, soil (in) fertility
9	Soil/coastal erosion, landslide	9	Human settlement, housing
10	Resource/species/biodiversity loss	10	Deforestation
11	Diseases; air-, food-, water-borne	11	Over-exploitation of resources, overfishing
12	Coral bleaching/health	12	Environmental degradation
13	Ocean acidification	13	Land use changes
14	Ocean current	14	Size
15	Cloud cover	15	Location, insularity
		16	Cost of adaptation
		17	Elevation – low
		18	Dredging, land reclamation
		19	Ownership of land, complex tenure arrangements
		20	Lack of insurance
		21	Limited credit availability

The latest country's population estimate indicates that around 98.000 people live in the country (World Bank 2019). Similar to what is observed in other SIDS, Seychelles is currently facing unprecedented threats to its viability because of the impacts of climatic and non-climatic induced vulnerabilities. The development in the Seychelles has occurred predominantly on the coastline that are vulnerable to the impacts of climate change such as sea level rise, coastal inundation, beach erosion, etc. (Rice et al. 2019). The vulnerability of the Seychelles is illustrated by the fact that it has suffered from several disasters in the last four decades, some of which are driven by climate change, while others are non-climatic (see Table 1).

Additionally, new patterns of rainfall distribution have emerged in Seychelles amidst increasing coastal development, compared to the situation two decades ago (SMA 2019). The consequences are constant flash floods that last for several days in Mahé especially during the month of May 2019. Continuous rainfall for 2–3 days wasn't a major problem some four decades ago. However, the current situation is different given the level of coastal development that has taken place especially



**Fig. 3** Average annual rainfall in the Seychelles between the years 1980 and 2018. (Source Seychelles Meteorological Authority)

during the last decade on reclaimed wetlands whose water table is very close to the surface and may require several days for water to drain into the soil after rainfall (Etongo 2019: 45). Seychelles' vulnerability to the impacts of climate change has raised concern in four main areas, and they include sea level rise, changes in rainfall patterns, coastal flooding, and extreme weather events (Government of Seychelles 2013). Adaptation is considered a priority in Seychelles and in other SIDS as a strategy to mitigate both climatic and non-climatic driven vulnerabilities through the implementation of different adaptation actions. The next section of this chapter describes some of the adaptation interventions implemented in the Seychelles together with their pros and cons.

## An Overview of Adaptation Measures in the Seychelles

A portfolio of approaches and interventions have been implemented in Seychelles, in order to adapt to the impacts of climate change. This section outlines some of them.

### Hard Engineering Techniques

Hard engineering actions to adaptation in the Seychelles include highly visible, man-made structures, such as rock armoring, retaining walls, and groynes in order to protect especially the coastal and critical infrastructures such as roads, schools, hospitals, etc. (Rice et al. 2019). It is argued that hard adaptive measures involve capital-intensive, large, complex, inflexible technology, and infrastructure, whereas



**Fig. 4** Severe erosion at Anse Marie-Louise on Praslin Island highlighting coastal erosion (a) and the construction of rock armoring (b) to mitigate the impacts of coastal erosion (MEECC 2019)

soft adaptive measures prioritize natural capital, community control, simplicity, and appropriateness (Sovacool 2011). **Rock armoring** involves the placement of large rocks piled or placed at the foot of dunes in areas prone to erosion or in areas that have been severely eroded. A good example is the case of Anse Marie-Louise on Praslin Island (Fig. 4). Geo-textile fabric is usually placed behind and across the rock placements. The rocks absorb the wave energy and hold beach material. With time, the accretion of sand could result in the formation of new beaches (MEECC 2019).

The Seychelles' sea walls have been constructed of stone, timber piling, and rock armoring (Rice et al. 2019). **Sea walls** made of stone were mostly constructed during the colonial era, are low in height, and currently compromised by wave action and, therefore, rarely used today. Timber piling has been a more recently utilized strategy, and it incorporates EbA approaches such as dune restoration and replanting of native coastal vegetation. The success rate for this type of strategy is inconsistent. Most of the recent reclamation work on Mahé has been equipped with rock armoring and sea walls. Although these methods have proved to prevent coastal erosion, however, it is frequently considered an eyesore (Government of Seychelles 2017).

## Soft Engineering Techniques

Soft engineering options are considered less expensive than hard engineering techniques. They are usually more long term with less impact on the environment. Examples of soft engineering adaptation actions implemented in the Seychelles include timber piling, beach nourishment, sand dune management, and the most recent being EbA. Due to their relevance, they are herewith described in turn:



**Fig. 5** Timber piling for coastal protection on Praslin Island (World Bank and MEECC 2019)

### **Timber Piling**

This method provides a physical barrier protecting unprotected dune-land from the direct hit of surging waves as has been implemented across the Seychelles. Geo-textile fabrics are placed behind and across the length of the wooden structures to complement the wooden pilings to trap sand that is washed up with the onshore transport of sediments by wave action (see Fig. 5). Backfilling with sand is implemented to allow the dune-land to recover more quickly than it would to further stabilize dune-land restoration and stabilize timber piling (World Bank and MEECC 2019).

### **Beach Nourishment**

Beach replenishment or nourishment is a technique used in coastal defense management schemes. It involves importing sand off the beach and piling it on top of the existing sand, and this adaptation action has been implemented at different vulnerable beaches on Mahé Island in the Seychelles (Fig. 6). The imported sand, however, must be of a similar quality to the existing beach material so that it can integrate with the natural processes occurring there without causing any adverse effects (World Bank and MEECC 2019).

### **Sand Dune Management**

Sand dune stabilization or sand dune management is used to prevent the loss of sediment on the beach. This method has been strengthened by coastal re-vegetation whereby selected coastal plants are planted to protect the dune-land vegetation and



**Fig. 6** Beach nourishment project at the North East Point beach, Mahé Island (MEECC 2019)

stability (Fig. 7a). The construction of boardwalks (Fig. 7b) and bollards (Fig. 7c) has helped to stop the removal of sediments by anthropogenic activities especially across some hotspot areas on the North-East Point beach on Mahé Island.

### **Ecosystem-Based Adaptation**

Ecosystem-based Adaptation (EbA) is a set of adaptation policies or measures that consider the role of ecosystem services to respond to the adverse impacts of climate change and can be used at multiple scales and in different sectors (Munang et al. 2013). EbA initiatives just like the Ecosystem-Based Adaptation to Climate Change in Seychelles that started in 2011 supported development aspirations and adaptation objectives through the sustainable management of biodiversity and ecosystems (Khan and Amelie 2014). This project uses nature-based methods through the application of technical solutions at specific watershed and coastal sites such as reinforcing access to water, reprofiling of wetlands, and mangrove restoration (see Etongo 2019: 53). Coral reef restoration is another example of EbA projects that often entails the utilization of species resistant to bleaching and is considered a promising technology in Seychelles. There has also been wetland restoration work around Port Launay, Roche Caiman, and the freshwater marsh at North East Point. This work often entails the cleaning and replanting of mangrove areas.

The EbA project is considered a win-win for climate change and livelihoods because the forests and wetlands of Seychelles granitic islands play an important role



**Fig. 7** Re-vegetation at *Anse à La Mouche* (a), constructed boardwalk at *Grand Anse* (b) and bollards (c) to protect dune-land from vehicles at *Anse Royale* (MEECC 2019)

in regulating stream flows and water quality. Forested land binds the soil, thereby decreasing soil erosion and increasing the capacity of soils to absorb and retain water. This allows water to penetrate deeper into the soil, allowing for less runoff and slower release. Wetlands and riparian vegetation also assist in reducing erosion while slowing water discharge over a longer period. The benefits include ameliorating the effects of climate change on water supplies by providing more regular stream flow during the lengthier dry season and, secondly, buffering against flooding following intense rainfall events. Similarly, mangroves and fringing coral reefs protect coastal land against coastal erosion, while coastal sand dunes and wetlands play an important role in controlling coastal flooding (UNEP 2017). All of these adaptation actions be it hard or soft that have been implemented in the Seychelles have their pros and cons as shown in Table 2.

Although some initiatives can potentially foster adaptation in the short term, there is a risk that they affect the environments', sectors', and people's long-term capacity and opportunities to cope with and manage the impacts of climate change (Magnan et al. 2016). Such a situation is considered as maladaptation. Climate change requires people to adjust ("adapt"), and the inability of persons and communities to adjust to environmental or economic instability is a part of maladaptation. Furthermore, people must be able to adapt not only to new hazards and changing resources, but also to new development initiatives, and to changes in access to and control over resources (Eriksen et al. 2015). It is therefore imperative to take stock of the adaptation actions that have taken place or are ongoing in the Seychelles given her vulnerability to the impacts of climate change.

**Table 2** Summary of the pros and cons of adaptation actions in the Seychelles

Adaptation actions	Pros	Cons
<b>Hard engineering techniques</b>		
Retaining wall and groynes	Protects coastal and critical infrastructure	Very expensive to set up and to maintain
Rock armoring	Rocks absorb the wave energy and hold beach material	Logistically difficult to organize
<b>Soft engineering techniques</b>		
Timber piling	Physical barrier protecting unprotected dune-land	Timber may get used up over time
Beach nourishment	Replenishment technique helpful in coastal defense management	Requires constant importing of sand
Sand dune management	Prevent the loss of sediment on the beach	Requires careful maintenance
Ecosystem-based adaptation	Use the role of ecosystem services to respond to the adverse impacts of climate change	Needs to be combined with other techniques

## Barriers to Climate Change Adaptation in the Seychelles

There are many barriers to climate change adaptation in the country. These are:

- (i) Fragile institutions and inadequate governance related to climate change
- (ii) Limited scientific knowledge and understanding of how climate change impacts the country
- (iii) Financial constraints in supporting adaptation strategies
- (iv) Human resource capacity (Etongo 2019: 55), here exemplified by limited staff trained on climate change adaptation methods

Khan and Amelie (2014) reaffirmed that a major institutional challenge to adaptation in the Seychelles is its effective integration into development planning. Aside from financial support provided by international agencies, national funding on adaptation actions is not only limited but poorly documented. This is also a trend seen elsewhere in Africa (Leal Filho et al. 2017). A recent report on climate change expenditures across government entities in Seychelles for 2018 stood at 597,953 SCR (\$ 43,828.52) of which 20% of this figure correspond to adaptation and mitigation actions implemented by a single entity – the Public Utilities Corporation (CPEIR 2019: 12–13). Such low figures on adaptation for a country like Seychelles that consider it as national priority could partly be explained as estimates that do not match actual investments or lack of information from the private sector and difficulties in accounting for climate-related expenditures on adaptation.

Scientific knowledge and understanding on climate change adaptation in the Seychelles is another barrier partly due to fragmented knowledge on adaptation,

little investment in research related to adaptation, and also difficulties encountered in the co-production of climate information for decision-making (Etongo 2019). Decision-makers from a wide variety of professional backgrounds increasingly find that their work intersects with the subject of climate change. The level of scientific expertise required to work on complex climate change adaptation problems is quite high, and most decision-makers in the Seychelles, other SIDS, and developing countries – such as city planners, resource managers, health officials, and farmers – lack a solid foundation on the science of climate change. When tasked with integrating climate information into their planning processes, decision-makers in the Seychelles and most developing countries faces two main challenges: (1) they find it difficult to know what climate information and data are best suited for a particular problem, and (2) they often perceive that climate information and data coming out of the scientific community is not usable in decisions (Briley et al. 2015).

A lack of appropriate knowledge and quality data further widens the adaptation deficit margin in Seychelles and other developing countries. This knowledge gap could be linked to the intensity of impacts that are usually beyond our range of understanding as was the case of heavy rainfall leading to flash floods that lasted for several days during the last 2 weeks of May 2019 on Mahé Island (see Etongo 2019). Furthermore, it could be the lack of technical knowledge, skills, tools, and technology and financial resources to effectively engage in proactive adaptation measures. For example, climate forecast in the Seychelles is largely based on comprehensive data collected from the airport, while such data are available in other parts of Mahé and the outer island but with lots of data gaps. Therefore, there is a growing need to improve on the early warning systems and strengthen information and decision support systems for the population in general for climate proofing in the Seychelles.

Social and cultural barriers can emerge in response to pre-existing perceptions of risk, beliefs, values, and preferences that underpin the ways individuals and societies experience, understand, and respond to climate change (Armah et al. 2015). Jones and Boyd (2011) found that socially and culturally embedded characteristics reinforce internal community structures to resist adaptation actions perceived as undesirable. Research also suggests that barriers vary according to place and culture may act as a mediating influence in resisting environmental change, particularly where change is perceived to threaten sense of belonging and place attachment (Armah et al. 2015). The role of informal institutions as barriers to adaptation in Seychelles is often ignored. Informal institutions are typically seen as the “invisible” norms that govern behavior, like customary practices or traditions and, are often embedded in a culture (Hodgson 2006). Parking of cars in the dune area across some hotspot areas on Mahé Island have led to the construction of bollards (see Fig. 7c). However, it’s not feasible to construct bollards across all of these hotspot areas, and cars could be seen parked in such places especially during the weekends.

Legacy barriers are another set of adaptation barriers that are common in the Seychelles and other developing countries. According to Moser and Ekstrom (2010), the spatial/jurisdictional and temporal origin of these barriers relative to the location of the actor are important. One of the legacy barrier in the Seychelles that put to test the nation’s capacity to adapt to climate change relate to land use planning in the past



that affects drainage of rainwater (Etongo 2019). Majority of the development in Seychelles have occurred very close to the coastline either on reclaimed wetlands or at sites whose soil characteristics and/or water table is relatively high. Flash floods after heavy rainfall despite the availability of drainage systems is common in some neighborhoods in the Seychelles and is a barrier that is both remote and a legacy.

---

## Options for Overcoming Adaptation Barriers in the Seychelles

Adaptation is a continuous process and not an outcome, and overcoming adaptation barriers could ensure proactive adaptation action that are capable of accommodating new information and or challenges linked to climate variability and change.

Climate change adaptation is not a stand-alone. Therefore, promoting synergies between adaptation and mitigation especially within the framework of EbA projects in the Seychelles has the potential of delivering a win-win solution for livelihoods and the environment. Adopting an integrated approach to community-based adaptation (CbA) and EbA have gained traction over recent years among scientist, policymakers, and development practitioners. Integrating CbA and EbA can also offer a cost-effective way to tackle climate change by capturing communities' knowledge and experience in dealing with climate variability and change. CbA is a bottom-up process that builds on local needs and capacities. It is based on human rights-based approaches that target the most vulnerable people and fully includes them in adaptation planning and implementation. It can also operate at scale, for example, through mainstreaming into government processes, but with communities remaining central to planning and action (IIED 2014). The Community Development Division in the Ministry of Local Government in the Seychelles could be used as an entry point into the various communities to improve adaptation through the integration of CbA and EbA actions.

In order to overcome the barriers that often arise during the co-production of climate information is to form direct partnerships with climate scientists to co-produce usable information for decision-making (Dilling and Lemos 2011). Collaboration between decision-makers and climate scientists offers an opportunity to leverage expertise from both parties to better serve problem-solving. Highly iterative interactions between decision-makers and scientists contribute to greater societal outcomes. The Seychelles National Climate Change Committee offers such platform for collaboration with the participation of a wide range of stakeholders from government, non-governmental organizations, research institutions, private sector, and community-based organization. However, this type of relationship requires a large investment of time, and the number of decision makers working on climate problems is much greater than the number of available partnering climate scientists (Bidwell et al. 2012).

Cross-sectoral and institutional collaboration is another option in overcoming most of the adaptation barriers that are institutionally driven. Collaboration across sectors will avoid the duplication of projects and improve on the efficient use of the limited financial resources nationally available for adaptation. Ford and Berrang-Ford (2014) are of the opinion that overcoming such barriers would require

consistency, comparability, comprehensiveness, and coherency which they described as the 4Cs of adaptation tracking. The University of Seychelles offered a three-day short course in July 2019 on the topic mainstreaming climate change adaptation into development planning. This course provided a platform for different stakeholders to gain knowledge on mainstreaming adaptation into policy, across sectors and within projects. Additionally, the Global Climate Change Alliance (GCCA+) Seychelles have provided several trainings on climate change across different institutions in Seychelles during the last 2 years. The most recent was a training on early warning system that took place in the month of August 2019 at the Seychelles Meteorological Authority (SMA) office.

Furthermore, the very first climate change policy for the Seychelles and the Third National Communication to the UNFCCC offers another opportunity to improve climate change adaptation in the country. A proactive climate policy should be coherent with other national development strategies. Some of these strategies are Seychelles Sustainable Development Strategy, National Communications in addition to Seychelles National Disaster Management Policy, and various legal mandates on environmental protection such as the Environmental Management Plan among others. Informal institutions that are rooted in culture or way of life might require new ways of doing things or a change in behavior in order to improve the adaptive capacity of Seychelles. A very good example in the Seychelles is the parking of cars in the dune area. Creating car parks in specific areas where land is available and convenient could partly address this problem. On the other hand, a wheel clamp policy could be implemented for those parking their cars in the dune area across different hotspots in the Seychelles. Institutional capacities, in particular measures of good governance such as participation, rule of law, accountability, transparency and responsiveness, etc., are the strongest predictors of national adaptation policy in the Seychelles and elsewhere (Berrang-Ford et al. 2014).

The role of local knowledge in adaptation to climate change is invaluable in reducing the vulnerabilities of communities to the impacts of climate change. However, there are concerns over its relevance for future adaptation amidst other challenges. Evidence from a study conducted in Tanzania suggests that local knowledge may contribute to adaptation to climate change in a number of ways especially when integrated with scientific knowledge (Naess 2013). Local knowledge especially among the fishing folks in the Seychelles is an important knowledge system that could be documented. Local indicators of climate change impacts based on local knowledge have the potential to improve our understandings of how climate change affects the environment and the blue economy in the Seychelles. The fishing folks interact with the ocean space frequently and have accumulated local knowledge that could feed into early warning systems.

Finally, remote/legacy barriers are those barriers that are most difficult to address in the “here and now,” as the locus of control is elsewhere and the origin of the barrier in the past. The three dominant types of such barriers include institutional ones such as the existing or missing governance structure and laws, economic and funding issues (such as the global economic crisis or state budget cuts), and attitudinal issues (the public’s attitude, awareness and understanding of climate change, or longstanding personality conflicts). Since the year 2015 of its existence,

Seychelles' Conservation and Climate Adaptation Trust (SeyCCAT) have provided financial support nationally for several research projects and small businesses in Seychelles related to climate change. Therefore, intervention in this case is remedial and compensatory by local actors: those who can and those who take it upon themselves "to break eggs" in order to make "omellette" – a view supported by Ekstrom and Moser (2014).

---

## Conclusions

Several actions have been taken to improve climate change adaptation in Seychelles such as hard and soft engineering and policy options. These actions include policy development and revision, institutional setup, rock armoring, bollards, retaining walls, mangrove and coral restoration, rainwater harvesting, EbA approaches, human resource capacity development, research, education, and outreach. Despite such efforts to reduce the vulnerability of the Seychellois population to the impacts of climate change, several barriers hamper the adaptation process. Chief among these barriers include institutional and governance issues, scientific knowledge and understanding, financial issues, and human resource capacity. Adaptation actions are likely to be hindered by poor governance which in some cases is not limited to formal but also to informal institutions that are linked to cultural belief systems or a way of life. Parking of cars in the dune areas are "invisible" norms that govern behavior like customary practices or traditions often embedded in a culture.

Some proposed strategies to overcome these barriers include promoting synergies between adaptation and mitigation into sectorial policies and national development. Collaboration across institutions should be enhanced to avoid duplication of projects and also to share resources and expertise. In order to overcome barriers that often arose during the co-production of climate information is to form direct partnerships with climate scientists to co-produce usable information for decision-making. Furthermore, the community development division under the Ministry of Local Government should serve as an entry point to promote the integration of CbA and EbA actions across all the districts in the Seychelles. This will not only re-invent the wheel but will also harness local knowledge systems that are fast eroding while strengthening community participation in a bottom-up approach in the fight against the impacts of climate change. The role of technology transfer could solve some of the legacy problems and lesson could be learned from the Netherlands on what types of drainage systems to construct given that the water table in some locations in the Seychelles especially on Mahé Island is very close to the surface.

---

## References

- Armah FA, Luginaah I, Hambati H, Chuenpagdee R, Campbell G (2015) Assessing barriers to adaptation to climate change in coastal Tanzania: does where you live matter? *Popul Environ* 37 (2):231–263

- Berrang-Ford L, Ford JD, Paterson J (2011) Are we adapting to climate change? *Glob Environ Chang* 21:25–33
- Berrang-Ford L, Ford JD, Lesnikowski A, Poutiainen C, Barrera M, Heymann SJ (2014) What drives national adaptation? A global assessment. *Climate Change* 124:441–450
- Bidwell D, Dietz T, Scavia D (2012) Fostering knowledge networks for climate adaptation. *Nat Clim Chang* 3:610–611
- Briley L, Brown D, Kalafatis SE (2015) Overcoming barriers during the co-production of climate information for decision-making. *Clim Risk Manag* 9:41–49
- Climate Public Expenditure and Institutional Review (CPEIR) (2019) Part 3: expenditures review. The global climate change alliance plus initiative. The Republic of Seychelles
- Dilling L, Lemos MC (2011) Creating usable science: opportunities and constraints for climate knowledge use and their implications for science policy. *Glob Environ Change Hum Policy Dimens* 21:680–689
- Ekstrom JA, Moser SC (2014) Identifying and overcoming barriers in urban climate adaptation: case study findings from the San Francisco Bay Area, California, USA. *Urban Clim* 9:54–74
- Eriksen SH, Nightingale AJ, Eakin H (2015) Reframing adaptation: the political nature of climate change adaptation. *Glob Environ Chang* 35:523–533. <https://doi.org/10.1016/j.gloenvcha.2015.09.014>
- Etongo D (2019) Climate change adaptation in Seychelles: actors, actions, barriers and strategies for improvement. *Seychelles Res J* 1(2):43–66
- Ford JD, Berrang-Ford L (2014) The 4Cs of adaptation tracking: consistency, comparability, comprehensiveness, Coherency. *Mitig Adapt Strat Glob Change*. <https://doi.org/10.1007/s11027-014-9627-7>
- Government of Seychelles (2009) Seychelles National Climate Change Strategy. The Seychelles National Climate Committee, Victoria, Seychelles
- Government of Seychelles (2013) Seychelles damage, loss, and needs assessment 2013 floods. A report by the Government of Seychelles. With support from the EU, UN, and World Bank. Victoria, Seychelles
- Government of Seychelles (2017) Seychelles technology needs assessment report – adaptation. Ministry of Environment, Energy and Climate Change, Victoria, Mahe Island, Republic of Seychelles
- Guillotreau P, Campling L, Robinson J (2012) Vulnerability of small island fishery economies to climate and institutional changes. *Curr Opin Environ Sustain* 4:287–291
- Hodgson GM (2006) What are institutions? *J Econ Issues* XL(1):1–25
- IIED (2014) Ecosystem- and community-based adaptation: learning from natural resource management. The International Institute for Environment and Development (IIED), London. Available online at <http://pubs.iied.org/17243IIED>
- IPCC (2007) Climate change 2007: synthesis report. Contribution of working groups I, II and III to the fourth assessment report of the intergovernmental panel on climate change (ed: Core Writing Team, Pachauri RK Reisinger A). IPCC, Geneva, 104pp
- IPCC (2018) Summary for policymakers. In: Global warming of 1.5°C. an IPCC special report on the impacts of global warming of 1.5°C above pre-industrial levels and related global greenhouse gas emission pathways, in the context of strengthening the global response to the threat of climate change, sustainable development, and efforts to eradicate poverty. World Meteorological Organization, Geneva. Retrieved from [https://report.ipcc.ch/sr15/pdf/sr15\\_spm\\_final.pdf](https://report.ipcc.ch/sr15/pdf/sr15_spm_final.pdf)
- Jones L, Boyd E (2011) Exploring social barriers to adaptation: insights from Western Nepal. *Glob Environ Chang* 21(4):1262–1274
- Khan A, Amelie V (2014) Assessing climate change readiness in Seychelles: implications for ecosystem-based adaptation mainstreaming and marine spatial planning. *Reg Environ Chang*. <https://doi.org/10.1007/s10113-014-0662-4>
- Leal Filho W, Belay S, Kalangu J, Menas W, Munishi P, Musiyiwa K (eds) (2017) Climate change adaptation in Africa- fostering resilience and capacity to adapt. Springer, Cham
- Magnan AK, Schipper ELF, Burkett M, Bharwani S, Burton I, Eriksen S, Gemenne F, Schaar J, Ziervogel G (2016) Addressing the risk of maladaptation to climate change. *WIREs Clim Change*. <https://doi.org/10.1002/wcc.409>

- Ministry of Environment, Energy and Climate Change (2019) Use of soft and hard engineering approaches to coastal zone protection in Seychelles. Available online at <http://www.meecc.gov.sc/index.php/what-we-do/coastal-protection-management/>
- Moser SC, Ekstrom JA (2010) A framework to diagnose barriers to climate change adaptation. *Proc Natl Acad Sci* 107:22026–22031
- Munang R, Thiaw I, Alverson K, Mumba M, Liu J, Rivington M (2013) Climate change and ecosystem-based adaptation: a new pragmatic approach to buffering climate change impacts. *Curr Opin Environ Sustain* 5:67–71
- Naess LO (2013) The role of local knowledge in adaptation to climate change. *WIREs Clim Change* 4:99106. <https://doi.org/10.1002/wcc.204>
- Nurse LA, McLean RF, Agard J, Briguglio LP, Duvat-Magnan V, Pelesikoti N, Tompkins E, Webb A (2014) Small islands. In: Barros VR et al (eds) *Climate change 2014: impacts, adaptation, and vulnerability part B: regional aspects contribution of working group II to the fifth assessment report of the intergovernmental panel on climate change*. Cambridge University Press, Cambridge/New York, pp 1613–1654
- Rice H, Rolf B, Rumschlang J, Xie D (2019) Evaluating the impacts of sea level rise and storm surges on Seychelles' critical infrastructure. School for Environment and Sustainability, University of Michigan, Michigan
- Robinson S (2015) Climate change adaptation trends in small island developing states. *Mitig Adapt Strat Glob Change*. <https://doi.org/10.1007/s11027-015-9693-5>
- Roxy MK, Ritika K, Terray P, Masson S (2014) The curious case of Indian Ocean Warming. *J Clim* 27:8501–8509
- Scandurra G, Romano AA, Ronghi M, Carfora A (2018) On the vulnerability of Small Island developing state: a dynamic analysis. *Ecol Indic* 84:382–392
- Seychelles Meteorological Authority (2019) New patterns of rainfall distribution are emerging in Seychelles compared to two decades ago. <https://www.meteo.gov.sc/#/newsDetails>. Accessed 28 Aug 2019
- Sovacool BK (2011) Hard and soft paths for climate change adaptation. *Clim Pol* 11(4):1177–1183
- UNEP (2017) Terminal evaluation of the UN environment project 'Building capacity for coastal ecosystem-based adaptation in Small Island developing states'. Evaluation Office of UN Environment, Nairobi
- United Nations Conference on Environment and Development (UNCED) (1992) Rio de Janeiro, Brazil, 3–14 June 1992 – AGENDA 21
- Wilson SK, Graham NAJ, Fisher R, Robinson J, Nash K, Chong-Seng K, Polunin NVC, Aumeeruddy R, Quatre R (2012) Effect of macroalgal expansion and marine protected areas on coral recovery following a climatic disturbance. *Conserv Biol* 26(6):995–1004
- World Bank Group (2019) Seychelles. World Bank Open Data, Washington, DC
- World Bank, Ministry of Environment, Energy and Climate Change of Seychelles (2019) *Seychelles Coastal Management Plan: 2019–2024*. World Bank/Ministry of Environment, Energy and Climate Change of Seychelles, Washington, DC/Victoria

**Open Access** This chapter is licensed under the terms of the Creative Commons Attribution 4.0 International License (<http://creativecommons.org/licenses/by/4.0/>), which permits use, sharing, adaptation, distribution and reproduction in any medium or format, as long as you give appropriate credit to the original author(s) and the source, provide a link to the Creative Commons license and indicate if changes were made.

The images or other third party material in this chapter are included in the chapter's Creative Commons license, unless indicated otherwise in a credit line to the material. If material is not included in the chapter's Creative Commons license and your intended use is not permitted by statutory regulation or exceeds the permitted use, you will need to obtain permission directly from the copyright holder.





# Linking Adaptation and Mitigation Toward a Resilient and Robust Infrastructure Sector in Kenya

# 131

Onkangi Ruth, David Lagat, and Ondari Lilian

## Contents

Introduction .....	2694
Climate Change Issues Affecting the Built Environment .....	2697
Study Methodology .....	2698
Results .....	2699
Climate Change Mitigation and Adaptation Interventions in Nairobi City .....	2699
Conclusion .....	2709
References .....	2710

## Abstract

Sustainable city is an oxymoron to many especially in developing nations where the ever extending urban fabric has consequently degraded natural habitats, altered species composition, changed energy flows, and immensely affected biogeochemical cycles. This dims the vision of meeting the present needs with a nondecreasing level of well-being while not compromising that of the future

This chapter was previously published non-open access with exclusive rights reserved by the Publisher. It has been changed retrospectively to open access under a CC BY 4.0 license and the copyright holder is “The Author(s)”. For further details, please see the license information at the end of the chapter.

O. Ruth (✉)  
National Construction Authority, Nairobi, Kenya  
e-mail: [konkangi@gmail.com](mailto:konkangi@gmail.com)

D. Lagat  
Construction Research and Business Development Department, National Construction Authority,  
Nairobi, Kenya  
e-mail: [dvdlagat@gmail.com](mailto:dvdlagat@gmail.com)

O. Lilian  
ClayCo, Chicago, IL, USA  
e-mail: [nyanchyond@gmail.com](mailto:nyanchyond@gmail.com)

generations to meet theirs. Nairobi as other cities in peer nations is associated with socioeconomic vulnerabilities as well as visible and “invisible” ecological problems such as pollution, climate change, spatial competition, dependency in natural capital use, and congestion. Nevertheless, this is uniquely both a problem and a solution.

Nairobi has grown from a small railway station at the turn of the twentieth century to one of Africa’s largest cities. With this growth, comes an oversized ecological footprint and complex challenges of stresses and shocks. Infrastructure development in developing nations is gaining momentum. It is one of the development indicators and a major contributor to the GDP. However, it is very vulnerable financially and functionally to extreme weather events such as intense and prolonged periods of rainfall, inundation, low retreating rates of flood waters, increased temperatures, and unpredictable wind patterns. This study sought to establish the level of integration of adaptation and mitigation measures to climate change in selected infrastructure projects. It further evaluates the performance of key action plans, projects, and efforts made to enhance resilience to climate change. The study supports the integration of broad investment flows instead of the project-by-project approach.

---

**Keywords**

Climate change · Adaptation · Mitigation · Infrastructure · Policy · Cities

---

**Introduction**

There has been increased deliberate effort to build the technical capacity within cities in developing countries to combat climate change through developing long-term national climate action plans thus creating an enabling environment for low carbon development. However, mitigation of climate change has received more financial, technical support, and mention in policy documents compared to adaptation. Climate change is a current phenomenon and no longer an anticipated occurrence. Developing countries are very vulnerable to climate change and a lot of natural resource-driven economic development is ongoing. Therefore, there is need to embrace low emission development pathways which integrate climate adaptation and mitigation activities for future proofing of the built environment.

According to UNEP, sixty-six percent (66%) of infrastructure in developing countries is yet to be built. This is an opportunity to make carbon-efficient cities a reality and not just rhetoric. This uniquely makes developing world cities both a challenge and a solution to climate change. With this unique opportunity to have mitigation and adaptation march in lockstep as well as avert high carbon stranded assets in the future, emerging economy cities need to gravitate toward sustainable development and keep their carbon footprint low. Embracing a responsible resource consumption and production approach will not only avoid locking in of unsustainable lifestyles and technologies but will also concurrently support both adequate mitigation and adaptation measures to climate change.

Linking adaptation and mitigation is imperative if developing countries are to keep their emissions low in the face of future developments and if the overall carbon emissions globally are to be reduced to safe levels in the near future.

Developing countries as far as infrastructure is concerned need to be climate wise if they aim to avert retrogression (*economically and socially*). Being climate wise in the built environment means adding the data layer to planning and designing, conducting mapping of vulnerability for infrastructure assets, as per location, exposure level to climatic changes, sensitivity, type of asset, design life and its adaptive capacity to support adaptation actions, and disaster preparedness as the built environment expands with economic growth. Also, industry professionals need to have climate change adaptation and mitigation knowledge to incorporate it in design of current and future projects.

This can be achieved through integration of climate change adaptation and mitigation knowledge in the curriculum of construction industry professionals. Conducting research on suitability of materials for adaptation and mitigation and offering a knowledge platform for the same will support timely climate proofing for the ongoing delicate economic progress.

In addition, adaptation and mitigation can march in lockstep to enhance resilience through broad investment flows in policy, education, and planning by review of physical planning policies to support a negative feedback loop in growth and expansion. Planning needs to precede infrastructure development (Yigitcanlar and Kamruzzaman 2015). Government should not authorize any project in an area without prior and authorized physical planning. Further, every mega development project needs to have reliable enforceable measures stated in the Strategic Environment Assessment Study report to counter the positive feedback loop associated with the project. Further, Nairobi can adopt a form-based code that encourages building out instead of uncontrolled infill development. Incorporating population growth data, flood estimation in the design of roads, culverts, and stormwater drainage systems as well as wastewater infrastructure enacting policy to support uptake of protective engineering in the coastal area.

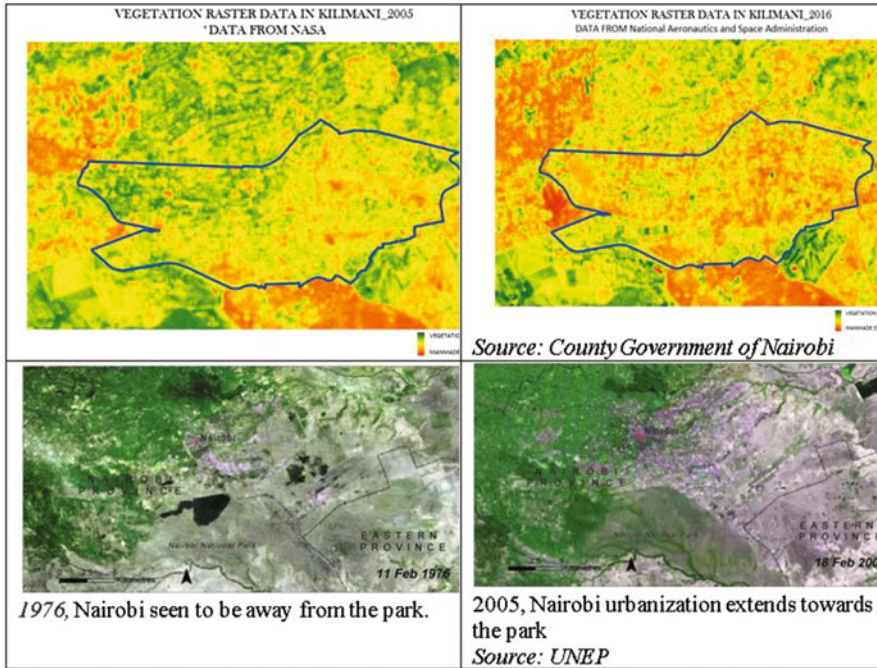
The National adaptation and mitigation plans need to have targets attached to sector-specific responses to climate change. This will support a coordinated response to climate change that will favor integration of broad investment flows instead of the project-by-project approach (*silos responses*).

The rapid growth and extending urban fabric in Nairobi bring with it an oversized ecological footprint and complex challenges including increased natural capital dependency more spatial competition and congestion. This rapid unsustainable development translates to rapid carbonization of developing country economies.

Environmental degradation in Nairobi has majorly and anecdotally manifested through:

1. Reduction in green spaces, over the years, as vegetation and trees are cleared to pave way for construction (see an attached satellite map in Fig. 1 showing the changes that have occurred over years in Kilimani area and around Nairobi National park) (*which translates to loss/reduction of carbon sinks*).
2. Shrinking and polluted blue features.





**Fig. 1** Spatial representation of decreasing green spaces in Nairobi

3. Increased use of motor transport and traffic congestion.
4. Sudden and rapid decrease of groundwater table due to less percolation as most surfaces are paved, and extraction rate of water exceeds recharge rates.
5. Flooding, water, noise, and air pollution.
6. Inadequate waste management-illegal dumping and inability to collect and dump at the designated place. The waste finds its way to drains hence causing blocking of stormwater drains and natural stream channels.
7. Heat island effect and increased energy use.

Despite devolution of the Government in Kenya, Nairobi's urban population is far from taking a plunge. Therefore, problems plaguing the city of Nairobi now need a lasting solution that will be immune to climatic changes for continuity and quality standard survival of progeny.

According to Kenya urbanization review conducted by World Bank, urban areas in Kenya at the moment play host to over ten million Kenyans. Nairobi hosts the majority with over four million people. World Bank estimates that by 2050 as many as 48.46 million people in Kenya will be living in cities this is equivalent to the country's entire present population (World Bank 2016). Rural to urban migration is informing the rapid expansion, however, the population of Kenyans migrating to cities is of a high fertility rate; this means urban population will continue to increase amid efforts to decentralize systems and discourage rural to urban migration (Hope 2012).

Consequently, as a proactive remedy, sustainable development is to be inculcated here and now in the face of future growth and expansion. Linking adaptation and mitigation in Nairobi will set precedence in other emerging urban areas as well as in two other developing cities in Kenya like Mombasa and Kisumu. If unsustainable urbanization as of the moment in Nairobi continues then the problem will be repeated in emerging urban areas hence weakening national future proofing efforts and further enhancing vulnerability. The reverse is also true; a success story of linking adaptation and mitigation to climate change in Nairobi will reverberate in the entire urban ecosystem of the country. This chapter evaluates level of integration of adaptation and mitigation measures to climate change in infrastructure projects (in three areas: climate data integration in infrastructure development, water security, and gray to green infrastructure ratio) in Kenya's capital as a partial and major contributor to the shift to sustainable city status.

### **Climate Change Issues Affecting the Built Environment**

According to the Intergovernmental Panel for Climate Change (IPCC) GCMs (Global Circulation Models), Kenya is likely to experience adverse climate changes between the late 2020s and 2100. The GCMs projections based on a grid resolution of  $200 \times 200$  km though having not included altitude modifications indicate that both rainy seasons are likely to become wetter especially the short rains that normally fall between October and December every year. Increased rainfall intensity events will lead to more flooding events in frequency and severity. Sea level rise will also have 17% of Mombasa (Kenya's second largest city) flooded.

The northern part of Kenya as per the GCMs will have 40% rainfall increases by 2100. By 2020s temperature are postulated to rise by  $1^\circ\text{C}$  and  $4^\circ\text{C}$  by 2100 (Parry et al. 2012).

These climatic changes will affect not just biodiversity, agriculture, and health aspects of the populace but infrastructure is vulnerable as well. By the fact that infrastructure underpins every sector, it is crucial to future proof assets to reinforce the efforts in other sectors to combat climate change for holistic resilience.

The infrastructure sector is vulnerable and responsible for climate change (to a large extent). Overall, the construction industry is responsible for one third of greenhouse gas (GHG) emissions. And depending on how you apportion it, buildings are contributing to almost half of GHG emissions.

Changes associated with climate changes are forecasted to contribute to degradation of infrastructure and building materials (Wilby 2007; Onkangi et al. 2019). Water availability is likely to affect demand and supply especially in prolonged dry spells; this can affect construction projects as they are heavily reliant on water. Increased precipitation will affect stormwater drainages, load, wastewater treatment systems and road networks causing project delays and reducing lifetime of infrastructure (Nelson et al. 2009; Onkangi et al. 2019). Cascading of failures due to linkages of infrastructure will have a knock-on effect on operations and the economy. Mitigation of and adaptation to climate change in the building sector are imperative (Onkangi et al. 2019).

Infrastructure more so in urban areas is interdependent especially through the water and wastewater systems as well as the drainage system. Infrastructure-to-infrastructure ties are also very present (water or non-water); therefore, weather-related disruptions whose genesis is hydrologic floods and intense precipitation can reverberate through the entire system. Therefore, management practices in one infrastructure will impact another (Onkangi et al. 2019; Wilbanks and Fernandez 2014).

The building sector like other sectors needs to play its part in lowering global temperatures to below 2 °C above preindustrial levels as agreed in the Paris Agreement 2015 in which Kenya is signatory to. The Building's day in the COP 21 gave birth to a commitment among participating nations that the construction sector will reduce emissions by 84 GtCO<sub>2</sub> by 2050 (Paris Agreement 2015).

Through “adaptable architecture” or “adaptable buildings,” both adaptation and mitigation can be adequately addressed in the built environment. Mitigation can be addressed through adaptation. “Adaptable architecture” or “adaptable buildings” are “concepts that feature flexibility in the function, physical form or experience in buildings along with a desire to develop systems for mass customization as well as pre-fabrication of building components with the end-use of buildings in mind” (Dave et al. 2016).

Where there is adequate planning, infrastructure informs cities. Greening infrastructure is the ignition key of a sustainable city. Nonetheless, mitigation and adaptation efforts in developing countries are biased to agriculture, human health, and biodiversity. Infrastructure is yet to be looped in adequately. It is crucial to ensure food security in the future, but if connectivity in the transport and communication is lost due to climate and weather-related interruptions then the farmer's produce fails to reach the market, and food security is jeopardized.

People spend 90% of the time in buildings, when adaptation to climate change is not incorporated in design and implementation then challenges due to extreme weather events compromise user comfort and threaten overall well-being (Klepeis et al. 2001). The research on building failures in Kenya indicated that more collapses happened in the rainy season. With climate projections indicating increased rain intensity and flash flooding in the future, a major threat looms for nonresilient assets whose numbers are evidently not few neither are the users (NCA 2017).

---

## Study Methodology

Through desktop study and literature review, criteria for evaluating mitigation and adaptation measures shown in Fig. 2 were adopted. In the period of August 2016 and November 2016, a descriptive survey tool of 72 structured questionnaires assessing the measure was administered to contractors, engineers, architects, quantity surveyors, construction firms, project managers, and construction managers. 51 questionnaires dully filled were collected giving a response rate of 71%. Further, desktop study, observation, and assessment of infrastructure more so where failures were reported yield information to complement the feedback from questionnaires on

Infrastructure Adaptation	Infrastructure Mitigation
<ul style="list-style-type: none"> <li>• Policy and legislation on adaptation of infrastructure to Climate Change (CC)</li> <li>• Infrastructure climate change adaptation plan</li> <li>• Incorporation of adaptation to CC in the Building code</li> <li>• Capacity building of industry professionals on adaptation to CC</li> <li>• Integration of adaptation measures to climate change</li> <li>• Political goodwill</li> <li>• City specific Climate data availability</li> <li>• Level of integration of climate data in design and construction</li> <li>• Disaster response system for infrastructure</li> <li>• Level of integration of the data layer in infrastructure development</li> </ul>	<ul style="list-style-type: none"> <li>• Sector specific policy and legislation on mitigation</li> <li>• Infrastructure climate change mitigation plans</li> <li>• Perceptions and attitudes to incorporating mitigation measures</li> <li>• Sectoral mitigation targets</li> <li>• Grey to green infrastructure ratio</li> <li>• Operational Knowledge</li> <li>• Commitments to Multilateral agreements on sustainable and climate resilient cities</li> <li>• Level of integration of climate data in design and construction</li> </ul>

**Fig. 2** Adaptation and mitigation evaluation criteria

integration of mitigation and adaptation. These findings gathered from the expert community were analyzed using SPSS, and the evaluation forms the bulk of this chapter.

## Results

### Climate Change Mitigation and Adaptation Interventions in Nairobi City

#### Gray to Green Infrastructure Ratio

The green infrastructure concept is an integrated approach that connects services, ecology, land use, and heritage. This “joined up” thinking delivers critical environmental services presenting a sustainable alternative to growth and development while upholding both mitigation and adaptation measures. Green infrastructure is multifunctional compared to gray infrastructure that is mostly single function. Both are critical and investment in both should be simultaneous. With decreasing green spaces, Nairobi has increasingly experienced the harshness associated with their reduction and loss.

Nairobi’s builtscape was previously nested in green spaces. The world’s only urbanite national park, an array of city parks, botanical gardens, and arboretum earned Nairobi the title “green city in the sun.” However, the spaces have been decreasing as shown in Fig. 1.

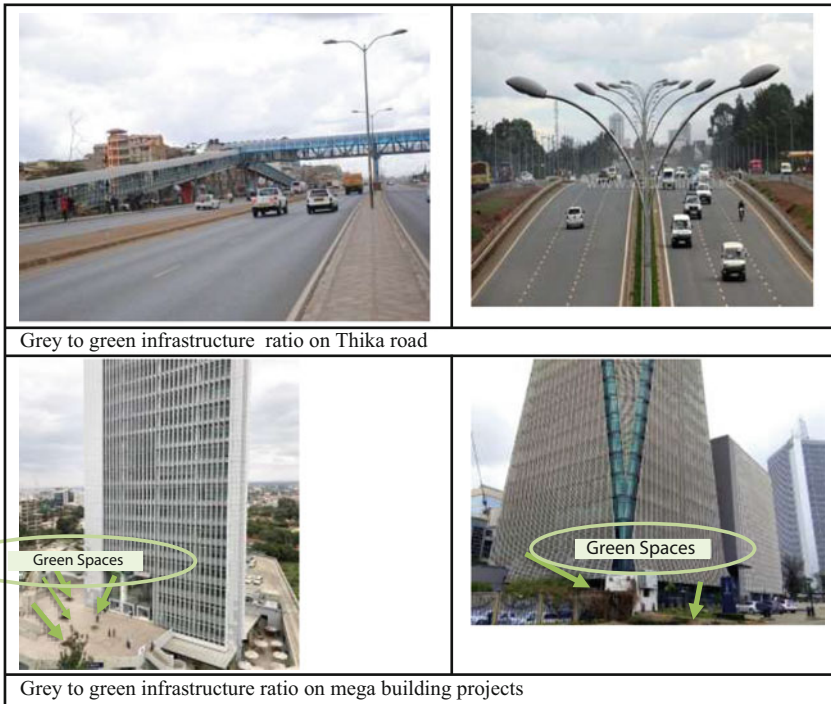
The new construction projects including roads in Kenya such as Thika road have a high gray to green infrastructure ratio, see Fig. 3.

As the urban fabric continues to extend, green spaces continue to shrink (see Fig. 1). The concrete jungle is gaining dominance. In many Environmental Impact

Assessment project reports, developers commit to landscaping and site restoration as far as possible. In the Environment Impact Assessment (EIA) reports, each project needs to state and commit to adaptation and mitigation measures adopted to combat climate change. But there are no set targets of the percentage of the project area that should be landscaped in the EIA reporting. This indirectly encourages the high gray to green infrastructure ratio. As seen in Fig. 3, lofty expansive buildings have dots of green spaces as part of landscaping and for aesthetics.

However, there is lack of targets on what percentage of the project area should have open spaces. Neither is there a policy push to have pervious spaces given a percentage priority in open space management. To create space for parking, many of the spaces surrounding are highly paved. The green to gray ratio in projects needs to be given a baseline per square meters of gray space; there should be greening of an equivalent space to counter negative impacts guided by adaptation and mitigation targets. The Government is yet to offer incentives to encourage sustainable construction to counter high paving of buildings. Policy to encourage silo parking and green roofing is a better option.

Illegally, numerous projects more so in low income neighborhoods construct beacon to beacon. And in upmarket areas, service paving is widespread. Increased paved surfaces ushered by rapid urbanization with gray infrastructure has aggravated



**Fig. 3** Green to gray infrastructure ratio in mega projects



**Fig. 4** Poor solid waste management has aggravated inundation in Nairobi

inundation as flood waters flow rapidly to rivers rather than being slowed by natural means through underground seepage and uptake by vegetation (green infrastructure). In addition, natural and manmade channels have been obstructed due to poor management of solid waste as shown in the Fig. 4.

The old concept of draining water away from cities through stormwater collection is not only contributing to pollution of water bodies but water insecurity in the face of climate change as aquifers are not recharging at the same rate as extraction. Population explosion has also overwhelmed the drainage system and increased urbanization of river catchment areas through illegal settlements and encroachments (Douglas et al. 2008). Consequently, small downpours translate to flash floods due to surface runoff from the paved surfaces and drains. Wastewater systems get overwhelmed, and sewage overflows are a common site. Further, in cases where rivulets and stormwater flows through a series of concrete passages and culverts, they are unable to adjust to rain intensity and frequency as natural streams do. This is largely attributed to lack of incorporation of the demographic data layer in city planning, infrastructure design, and construction.

### Depleting Aquifers

With the heavy downpour in certain periods of the year, the water table in Nairobi is still receding at a fast rate threatening subsidence of buildings. According to numerous studies and the National Environment Management Authority, increased hard paving and construction of buildings has reduced percolation to recharge the groundwater. Vegetation, soft landscaping, or pervious paving systems are crucial for recharge and cooling. However, wide hard paving as is the case in Nairobi at the moment causes most of the rainwater flows as surface runoff and is rapidly conducted to streams and rivers due to a high gray to green infrastructure ratio.

As the built environment has extended, the groundwater level has decreased, this is evidenced in various studies. Through the years with growing demand the number of boreholes sunk in Nairobi has increased drastically from 2 in 1927 to over 2500 in the year 2009 (Mathu et al. 2014). Also, the average depth of the water table has alarmingly decreased. In 1920s boreholes were sunk to a depth of only 20–22 m.

As of 1950, the groundwater level was 80 m deep while in 1996 it was about 140 m. This has been receding further at a rate of 1.8 m per month or even faster (Mathu et al. 2014; Olingo 2011; Foster and Tuinhof 2005).

The study by Mathu, Onyancha, Mwea, and Ngecu (2014) on “Effects of Drilling Deep Tube Wells in The Urban Areas of Nairobi City, Kenya” where the researchers used Surfer 9 software to analyze level of groundwater static variations in space and time in boreholes between 1927 and 2009, established that “groundwater rest levels have dropped with an average of 79 m in the last 80 years and a probable settlement of 0.34 m to 5.9 m could result from groundwater depletion from aquifers and clay aquitards over a long period of time. This should serve as a wakeup call to put up measures that can mitigate subsidence and the related consequences in Nairobi City.” The study also verified that 67% of the drop in groundwater rest levels has happened in the last two decades with sinking of boreholes in thousands (Mathu et al. 2014). The law requiring boreholes to be sunk at least 100 m apart is also not observed (Kenyan Parliament 2016). There is a continued scramble and siphoning of the Nairobi groundwater. The biophysical transformation due to urban sprawl is not making it better due to little recharge.

### Heat Island Effect

The heat island effect serves as the basic climate response to urbanization. Due to Nairobi’s location at the tropics, the heat island effect is not as significant as it is in cities located in the temperate regions. “An investigation of urban heat island phenomenon in Nairobi” by Reginald Ambona over the period of 1991–2011 using the wind rose technique to examine presence of the heat island plume confirmed that Nairobi experiences heat island effect though not large enough (Amboga 2013). This was similarly observed in an earlier study which warned that with current trends of population increase, greater motor vehicle density and higher industrialization and urban spread, the anthropogenic waste heat ejection would be large enough to modify the heat balance of Nairobi city appreciably by the year 2030 (Opijah et al. 2008).

In 2009, Makokha and Shisanya found that cooling and warming rates were highest at the suburban study site and lowest at the urban canyon study site. The built environment in the study sites explained the differential cooling and warming rates. The study recommended proper planning of the built environment to ameliorate the problem of excessive nocturnal heat loads within the built environment (Makokha and Shisanya 2010).

A similar study by Silas Owiti in 2016 indicated that there is a growing distribution of heat islands in Nairobi. There was negative correlation between land surface temperature (LST) and normalized difference vegetation index (NDVI) implying that vegetation alleviated the heat island effect, while the positive correlation between LST and urbanization indicated that the urbanization increases the heat island effect. Owiti’s study concluded that with the rate of urbanization, the distributed heat island effect, with time will conglomerate into a large heat island in the city (Owiti 2016).

These results are attributed to infill development as well as urban sprawl in Nairobi which is causing enormous vegetation loss. Impervious surfaces such as buildings, parking spaces, and tarmac roads have affected the heat balance regulated by the natural ecosystem.

Passing environmental laws, policies, action plans that are definite and give project specific binding targets on mitigation will help foster sustainability. In addition, project environmental audit reports should include mitigation and adaptation achievements and opportunities. Providing a business case for integrating climate action in city projects as well as creating a knowledge platform and increase awareness on adaptation and mitigation for infrastructure projects will support adoption of environmental stewardship in the built environment in Kenya.

### **Transport Infrastructure**

The 1997/1998 El Niño rains are estimated to have caused the country's roads, water supply infrastructure, buildings, and telecommunication infrastructure damage of US\$0.8–1.2 billion equivalent to 11% of Kenya's GDP (MoE 2010, 2013). "Other losses amounting to US\$9 million arose from flooding, property destruction, soil erosion, mudslides and landslides, surface and groundwater pollution and sedimentation of dams and water reservoirs" (MoE 2013).

The National Climate Change Action Plan 2013–2017 directs that "new investments in infrastructure must consider expected changes in temperature and precipitation." According to the Plan for a low carbon climate-resilient pathway, infrastructure should be "climate proofed" the plan elaborates on climate proofing to mean "designed, constructed and operated in a way that accounts for anticipated risks and opportunities that result from climate change, ensuring that infrastructure investments are not compromised in the future." Further, it states the need to account for sea levels rise in infrastructure, port facilities, roads, railways, and bridges.

However, emerging from this study is that there is low integration of climate data in new infrastructure development. The sector is yet to adopt action plan measures to enhance resilience, ongoing, and newly completed projects use historical data, but future predictions are not factored in. This is attributed to level of availability of meteorological (met) data. Many study respondents indicated that they do not have access to meteorological data and that which is available is expensive thus adding to the project costs.

A price-based economy is seemingly not supporting many key interventions that could be costly in the short term but avert bigger costs in the long term. Also, the met stations are few, monitor particular elements and inconsistencies in data records affect reliability.

The Government is building a sea wall to protect a monumental site (Fort Jesus) from sea level rise. The reactive adaptation to sea level rise on this centuries old monument is a step in the right direction; however, new developments are not taking up proactive adaptation measures against sea level rise as seen in the new Mombasa road by the seaside (see Fig. 5). Prioritizing maintenance of infrastructure in vulnerable areas, incorporating climate change in maintenance, and retrofitting of structures are recommended proactive measures for state and non-state entities to increase adaptation to climate change.





**Fig. 5** The new Mombasa road by the seaside in Mombasa city

### **Thika Superhighway Case Study**

The 8-lane highway project by the Kenyan Government was done to reduce congestion and increase connectivity between the capital city and the industrial town of Thika. Endless hours were spent in traffic to and from the city when the road was only two lanes. However, the problem of traffic congestion still persists.

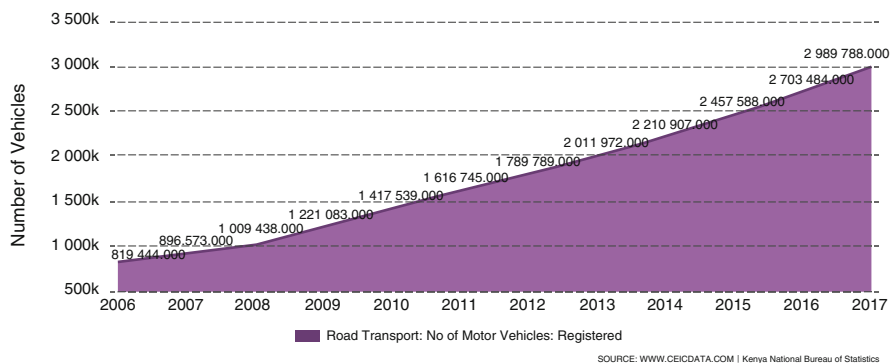
The climate action plan recommends a mass transit system Bus Rapid Transit (BRT) complemented with a light rail as mitigation measure against climate change. This measure is estimated to abate approximately 2.8 MtCO<sub>2</sub> emissions by 2030. At the moment there is a sharp increase in car ownership in Kenya. On average at least 20,000 cars are added to the Kenyan roads every month as illustrated in Fig. 6 majority of which are used in Nairobi metropolis.

The Government of Kenya is aiming to introduce BRTs in 2019 and has already marked dedicated lanes in the superhighway for the BRTs (see Fig. 7).

In addition, the Kenyan Government sought to introduce two car-free days every Wednesday and Saturday with the introduction of BRTs in 2019. These car-free days policy was dead on arrival due to lack of alternative means of transportation as the BRT is yet to arrive, and public consultation was not conducted. There has been wide resistance among the masses on the same leading to cancelation of the two car-free days (Okinda 2019; Ondieki 2019).

If the BRT system proves reliable in the long run, it will contribute to promoting sustainable transport and reduce emissions associated with personal car use. A major boost to mitigation efforts.

Introduction of BRT will also enable decongestion of the city roads and reducing traffic snarl ups. Laudable mitigation efforts. Nonetheless, the transport infrastructure needs to adapt to climate change. This same superhighway with lanes



**Fig. 6** Yearly number of motor vehicles registered in Kenya Road Transport. (Source: Kenya National bureau of Statistics)



**Fig. 7** Lanes marked on Thika superhighway for BRT buses to be introduced by the Kenyan Government in early 2019

marked for BRT has faced inundation challenges (see Fig. 8), as adaptation measures were not incorporated in design. The gray to green infrastructure is high, and future climatic predictions did not inform the design. Poor solid waste management exacerbates the problem due to blocking of drainages. Without



**Fig. 8** A flooded Thika superhighway after a downpour

incorporating adaptation measures, mitigation measures laudable as they may be will soon become laughable as the climate changes and weather events become extreme.

The Government is currently constructing bypasses around the city to manage traffic as well as expanding city roads. This is a short-term solution as seen from Thika superhighway case. More road networks, more expansion, and more cars and BRT lanes adding to climate change. Any magnitude of rainfall even light showers causes unprecedented traffic snarl ups in all Nairobi city roads. One can only imagine how chaotic the scenario will be as the climate continues to change in an unpleasant manner. The impact that will have on the economy is big due to productivity losses as the human capital is wasted in traffic jams that also contribute to more carbon emissions – a double loss.

To adapt and mitigate accordingly the Government needs to implement policies that counter this positive feedback loop associated with road expansion or “reliable” transport. In the Thika road scenario after road expansion, settlement along the highway exploded. The population shifted to Thika roadside and mostly young people, with young families hence more and more cars on the road. Infrastructure in every aspect has been stretched, wastewater systems are strained, and sewage overflows are common and worse when it rains. Clean water supply to homes is increasingly inadequate as more apartments are added per mile. Adequate physical planning and dedicated implementation to guide human settlement will support mitigation measures and enhance adaptation.

### Non-motor Transport

Among the incremental investments required to ensure that all infrastructure developed is climate-resilient, Kenya's National Climate Change Action Plan envisions that bicycle lanes and sidewalks, to be developed in parallel with the transit system, will contribute to an emission reduction of 4.1 MtCO<sub>2</sub> of emissions by 2030 (MoE 2013).

New roads outside the central business district (including sections of Thika road) have cycling lanes; the old roads and those running through the central business district were not designed for cyclists as they lack cycling lanes. At some point a cyclist has to share a road with motorists as they make their way into the city. Cycling is a risky affair in most of Nairobi as motorists and cyclists have to share roads (see Figs. 9 and 10).

Cycling lanes are invaded by motorcycles that poorly observe road discipline. Pedestrians also leave sidewalks for cycling lanes. This fails to encourage uptake of non-motor transport in form of cycling.

This has not triggered nor supported a cycling culture. Besides cycling being viewed to be very risky, road discipline is very low for motorists and cyclists to share a road. The fact that the older roads were not designed for cyclists and lack of sufficient secure bicycle parking spaces indicates that local government leadership was not pro-cycling. The local government has banned public transport a couple of



**Fig. 9** Motorcycles using lanes designated for non-motor transport

**Fig. 10** Cyclist sharing a road with oncoming motorists



times which led to great inconvenience to commuters and the labor force. The idea succumbed to lack of alternative means for connectivity. Not once did the local government introduce bike share program as an alternative transport mode. Majority of the buildings also do not have cloak rooms with public showers to encourage a “cycle to work” culture, lack of pro-cycling policies do not favor a cycling culture or thinking to thrive. Legislating a policy to make accessories in every building that will encourage sustainable living basic is recommended. The policy can have a percentage of parking spaces and rest rooms dedicated for secure bicycle parking spaces, shower, and changing rooms.

Negative perceptions to cycling greatly contribute to its adoption level. A study by Mitullah and Makajuma (2013) analyzing non-motorized travel conditions on the Jogoo Road corridor in Nairobi established that 66% of the participants expressed views that riding a bicycle shows that one is poor: 3% of these strongly agreed to this, 19% agreed to it, and 44% felt somehow riding a bicycle is an indication of poverty. Therefore, to shift to sustainable modes of transportation requires education of the masses and example setting by the leadership to help eliminate such perceptions. Politicians embracing non-motorized transport will manage perceptions usher attitude change and show political good will.

### **Level of Integration of Climate Change Concerns in Design**

Temperature rise received the highest percentage in design consideration and material use as 53.8% of the respondents indicated. Anecdotally, following registered complaints from a number of occupants some new buildings are designed for a hot

climate. During cold season they are very cold necessitating use of heaters which raises energy use that upsets the sustainability message. But in hot season they have excellent occupant comfort.

A large number of participants (61.5%) indicated not giving high consideration to indoor climate in design aspects of a building. Water efficiency to improve water security was a high consideration to 38.5% of the participants and increased wind strengths was factored in design by 23.1% of the respondents.

Energy audit study jointly conducted by UN Habitat, University of Nairobi and Makerere established that buildings in East Africa designed before 1990 are more energy efficient while most of the buildings designed in the 90s are less energy efficient. This was attributed to abandoning of vernacular architecture for what is trending like glass building envelopes as they are aesthetically appealing without considering which materials the local environment supports or which materials support the local environment for occupant comfort.

### **Integration of Climate Adaptation into Transport Infrastructure Projects**

Thirty-one percent (31%) of study participants were very confident that culverts and stormwater drains can handle some percent increase inflow due to intense rainfall. Use of insurance schemes against flooding damages was reported by fifteen percent (15%) of the respondents. Insuring of buildings against collapses was reported by twenty-three percent (23%) of the participants.

---

## **Conclusion**

There is less target action in mainstreaming climate change in the infrastructure sector in Kenya. Climate change integration in infrastructure construction is very low. Barriers to taking action include low accessibility of met data to industry professionals, lack of sector specific laws and policies enforcing mainstreaming, low awareness of adaptation and mitigation measures for infrastructure, and perceptions of sustainability as a soft and foreign concept.

Uptake of measures stated in the National Climate Change Action Plan is very low in the infrastructure sector. The measures need to have targets attached to them. A low carbon development pathway is within reach of developing countries if they embrace both adaptation and mitigation measures in matching strength. The infrastructure sector in Nairobi has low resilience to climate change. Physical planning inadequacies and weak complimentary policies are reinforcing these weaknesses enhancing the city's vulnerabilities.

Overall mitigation has better attention than adaptation (Fig. 11).

There is a need to balance the equation (as shown in Figure 11) for a robust and resilient outcome in growth and development.

Climate change adaptation and mitigation in cities should not be addressed in isolation; attention should be given to all sectors to manage interlinkages and interconnectivities. While pockets of leadership are witnessed through a project by



**Fig. 11** Mitigation and adaptation need to be adopted in marching strength for climate resilience to be realized

project approach (*tokenism*), broad investment flows yield synergy that is more impactful, realize greater resilience, and harness robustness.

## References

- Amboga R (2013) An investigation of urban heat island phenomenon in Nairobi. Unpublished manuscript. University of Nairobi
- Dave M, Varshney A, Graham P (2016) Assessing the climate change adaptability of buildings. City Futures Research Centre, Sydney
- Douglas I, Alam K, Maghenda M, McDonnell Y, McLean L, Campbell J (2008) Unjust waters: climate change, flooding and the urban poor in Africa. *Environ Urban* 20(1):187–205
- Foster SSD, Tuinhof A (2005) The role of groundwater in the water supply of Greater Nairobi, Kenya. World Bank, GW-MATE Case Profile No 13
- Government of Kenya, Ministry of Environment (MoE) (2010) National climate change response strategy executive brief
- Government of Kenya, Ministry of Environment (MoE) (2013) National climate change action plan 2013–2017
- Hope K (2012) Urbanisation in Kenya. *Afr J Econ Sustain Dev* 1:4. <https://doi.org/10.1504/AJESD.2012.045751>
- Klepeis NE, Nelson WC, Ott WR, Robinson JP, Tsang AM, Switzer P, . . . Engelmann WH (2001) The National Human Activity Pattern Survey (NHAPS): a resource for assessing exposure to environmental pollutants. *J Exposure Sci Environ Epidemiol* 11(3):231
- Makokha GL, Shisanya CA (2010) Trends in mean annual minimum and maximum near surface temperature in Nairobi City, Kenya. *Adv Meteorol* 2010
- Mathu EM, Onyanha C, Mwea S, Ngecu W (2014) Effects of drilling deep tube wells in the urban areas of Nairobi city, Kenya. *ARPN J Earth Sci* 3(1):17–24
- Mitullah W, Makajuma G (2013) Analysis of non-motorised travel conditions on the Jogoo Road corridor in Nairobi. Retrieved from: [http://erepository.uonbi.ac.ke/bitstream/handle/11295/61279/Mitullah\\_Analysis%2bof%2bnon%2bmotorised%2btravel%2bconditions.pdf?sequence=1&isAllowed=y](http://erepository.uonbi.ac.ke/bitstream/handle/11295/61279/Mitullah_Analysis%2bof%2bnon%2bmotorised%2btravel%2bconditions.pdf?sequence=1&isAllowed=y)
- National Construction Authority (2017) Research on building failures in Kenya. Unpublished manuscript
- Nelson KC et al (2009) Forecasting the combined effects of urbanization and climate change of stream ecosystems: from impacts to management options. *J Appl Ecol* 46(1):154–163
- Okinda B (2019) Nairobi announces car-free days as BRT plan shapes up. Monday January 28 2019. Retrieved from: <https://www.nation.co.ke/news/Nairobi-finally-gets-car-free-days/1056-4955054-d42b8d/index.html>
- Olingo A (2011) Is your borehole water safe? Retrieved from: <https://www.standardmedia.co.ke/business/article/2000040134/is-your-borehole-water-safe>

- Ondieki E (2019) Kenyans oppose plan to have two car-free days in the city. Wednesday January 30 2019. Retrieved from: <https://www.nation.co.ke/news/Kenyans-oppose-plan-to-have-two-car-free-days-in-the-city/1056-4957582-12urcjcZ/index.html>
- Onkangi RN, Njiiri MP, Maklago E, Lilian O (2019) Vulnerability and adaptation levels of the construction industry in Kenya to climate change. In: Leal FW (ed) Handbook of climate change resilience. Springer, Cham
- Opijah FJ, Ng'ang'a JK, Omedo G, Mukabana JR (2008) Contribution to the heat budget in Nairobi-metro area by the anthropogenic heat component. *J Kenya Meteorol Soc* 2:1
- Owiti SO (2016) Urban heat island: investigation of urban heat island effect. A case study of Nairobi. Unpublished manuscript. University of Nairobi
- Paris Agreement, 2015
- Parry JE, Echeverria D, Dekens J, Maitima J (2012) Climate risks, vulnerability and governance in Kenya: a review. Commissioned by: Climate Risk Management Technical Assistance Support Project (CRM TASP), joint initiative of Bureau for Crisis Prevention and Recovery and Bureau for Development Policy of UNDP
- Wilbanks TJ, Fernandez S (2014) Climate change and infrastructure, Urban Systems, and vulnerabilities: technical report for the US Department of Energy in support of the National Climate Assessment. Island Press, Washington, DC
- Wilby RL (2007) A review of climate change impacts on the built environment. *Built Environ* 33:1
- World Bank (2016) Kenya urbanization review. World Bank, Washington, DC. © World Bank. <https://openknowledge.worldbank.org/handle/10986/23753>. License: CC BY 3.0 IGO
- Yigitcanlar T, Kamruzzaman M (2015) Planning, development and management of sustainable cities: a commentary from the guest editors. *Sustain* 7(11):14677–14688. <https://doi.org/10.3390/su71114677>

**Open Access** This chapter is licensed under the terms of the Creative Commons Attribution 4.0 International License (<http://creativecommons.org/licenses/by/4.0/>), which permits use, sharing, adaptation, distribution and reproduction in any medium or format, as long as you give appropriate credit to the original author(s) and the source, provide a link to the Creative Commons license and indicate if changes were made.

The images or other third party material in this chapter are included in the chapter's Creative Commons license, unless indicated otherwise in a credit line to the material. If material is not included in the chapter's Creative Commons license and your intended use is not permitted by statutory regulation or exceeds the permitted use, you will need to obtain permission directly from the copyright holder.







# Integrating Climate Adaptation, Poverty Reduction, and Environmental Conservation in Kwale County, Kenya

# 132

Chiara Ambrosino, Ben Hufton, Benson Okinyi Nyawade, Harriet Osimbo, and Phanuel Owiti

## Contents

Introduction .....	2714
Climate, Poverty, and Nature: Three Interconnected Societal Challenges .....	2714
Context: Kenya and Kwale .....	2716
Conservation and Sustainable Management of Marine Ecosystems in Kwale County Project .....	2719
A People-Centered Approach to Address the Triple Crisis at Local Level .....	2720
Local Environmental Stewardship .....	2721
Women's Inclusion and Agency .....	2723
Pro-poor Responsible Value Chain Development .....	2724
Findings and Recommendations .....	2725
Limitations of the Study .....	2727
Conclusions .....	2728
References .....	2728

## Abstract

Shoreline erosion, flood surges, river sediments, and water pollution are only a few of the common threats to many coastal areas, with extreme climate-related events exacerbating the intensity and urgency of the resulting negative impacts. In

This chapter was previously published non-open access with exclusive rights reserved by the Publisher. It has been changed retrospectively to open access under a CC BY 4.0 license and the copyright holder is "The Author(s)". For further details, please see the license information at the end of the chapter.

C. Ambrosino (✉) · B. Hufton  
Plan International UK, London, UK  
e-mail: [chiara.ambrosino@plan-uk.org](mailto:chiara.ambrosino@plan-uk.org); [ben.hufton@plan-uk.org](mailto:ben.hufton@plan-uk.org)

B. O. Nyawade · H. Osimbo · P. Owiti  
Plan International Kenya, Nairobi, Kenya  
e-mail: [benson.okinyi@plan-international.org](mailto:benson.okinyi@plan-international.org); [harriet.osimbo@plan-international.org](mailto:harriet.osimbo@plan-international.org); [phanuel.owiti@plan-international.org](mailto:phanuel.owiti@plan-international.org)

addition, some coastal areas are excessively mined for sand, protective mangroves are destroyed, and coastal waters are overfished, affecting the well-being, safety, and livelihoods of local communities. These threats disproportionately affect the poorest and most marginalized groups, including women and children, leading to their increased vulnerability to climate change and adoption of negative coping mechanisms.

This chapter proposes an integrated people-centered approach, with a particular focus on women, to address the triple crisis – poverty, climate change, and nature – at the local level. Findings will be shared from a 2-year project implemented in the southernmost coastal region of Kwale County in Kenya, which aimed to achieve beneficial and interconnected social, environmental, and climate outcomes. The chapter discusses findings, successes, and lessons learned from the action and the requirement to position vulnerable groups at the center of initiatives designed to address the triple crisis. Limitations of the study and main recommendations for future programming in similar contexts are also shared.

---

**Keywords**

Triple crisis · Climate change · Ecosystems · Nature · Coastal livelihoods · Poverty

---

**Introduction****Climate, Poverty, and Nature: Three Interconnected Societal Challenges**

Originally, 2020, now running into 2021 – due to the ongoing global pandemic – is expected to be a pivotal year for the promotion of a more sustainable and climate-resilient future. Major events are scheduled where decisions will be made around development targets (UN Sustainable Development Goals will be revised), conservation of biodiversity (UN Convention on Biological Diversity), and climate actions (review of the Paris Agreement targets).

In the last few years, there has been growing recognition among the scientific and development community that climate change, nature, and poverty are interconnected – often described as *triple crisis*, *triple emergency*, or *triple jeopardy*. Various publications and institutions are attempting to identify the linkages between the three areas and are currently promoting integrated approaches to better inform the Sustainable Development Goals (SDGs) and advocate for national and international policy changes (WWF-UK 2018; People and Nature Campaign 2019). In a review of recent literature, Howe et al. (2013) attempted to elucidate the linkages between climate change, ecosystem services, and poverty alleviation. The authors identified the need for further

research to focus on how those pathways work to promote policy changes and ways to adapt to and mitigate climate change on the ground.

There is significant evidence climate change has already affected and is likely to drive even more biodiversity and ecosystem services loss (Turner et al. 2012; Gosling 2013; Boone et al. 2018; van der Geest et al. 2019) over the coming decades. This disproportionately affects the poorest people and communities who rely on sustainable ecosystems for their livelihoods, health, climate regulation, shelter, security, and social relations. Worsening biophysical conditions such as ecosystem degradation, biodiversity loss, and less productive agricultural lands compromises people's ability to move out of poverty (Barbier and Hochard 2018; Hansen et al. 2019). Conversely, increased poverty is widely recognized as a key factor contributing to increased climate change vulnerability (Leichenko and Silva 2014).

While ecosystem services are essential to sustainable development and human well-being, they are also a key component in helping to adapt to changes in climate patterns, providing carbon sinks, and reducing disaster risk (MEA 2005; Munang et al. 2011; Temmerman et al. 2013; Lo 2016). According to the IPCC Special Report on Global Warming of 1.5 °C, there is high confidence that constraining global warming to 1.5 °C instead of 2 °C will result in many benefits for the preservation of ecosystem services to humans (Hoegh-Guldberg et al. 2018). With this in mind, the 14th UN Convention for Biological Diversity (CBD) in 2018 formally integrated climate change issues into national biodiversity strategies and vice versa, stating "that climate change is a major and growing driver of biodiversity loss, and that biodiversity and ecosystem functions and services, significantly contribute to climate change adaptation, mitigation and disaster risk reduction" (CBD 2018).

The role of ecosystem losses in the loss and damage to human well-being has also been a new emerging topic that needs further investigation (UNEP 2016). Since 2016, nature-based solutions (NbS) have received increasing levels of attention as sustainable solutions to meet societal challenges. A global standard for NbS is currently under public consultation, but two definitions are presented below. The IUCN defines NbS from the perspective of societal good as "actions to protect, sustainably manage and restore natural or modified ecosystems that address societal challenges effectively and adaptively, simultaneously providing human well-being and biodiversity benefits."

The EC definition of NbS focuses on an element of cost-effectiveness: "inspired and supported by nature, and which simultaneously provide environmental, social and economic benefits and help build resilience, with positive benefits in urban environments, landscapes and seascapes" (EC 2018). A further report released in May 2019 by the Intergovernmental Science-Policy Platform on Biodiversity and Ecosystem Services (IPBES) on biodiversity and ecosystem services highlighted the importance of promoting nature protection and restoration and its critical contribution to the global economy and people's ability to withstand future climate-related, economic, social, and additional environmentally driven shocks that a changing world may bring (IPBES 2019). Healthy mangroves, as an example, and the restoration of mangrove habitats, in particular, have been identified as important resources to help coastal regions withstand climate-related hazards and promote carbon sequestration (McIvor

et al. 2013; Murdiyarso et al. 2015) as well as support rich biodiversity and contribute to replenishing decreasing fish stocks (Hutchison et al. 2014; IUCN 2017).

While interest and investment in people-centered bottom-up approaches to address any one of those challenges have slowly increased, little attention has been paid to the potential those interventions have in helping people manage the triple crisis (Reid and Swiderska 2008).

This chapter provides an overview on the interconnections between climate-, nature-, and poverty-related challenges at the local level and in a coastal context and the role and benefits from taking an integrated pro-poor people-centered approach in addressing them.

Main findings are presented from a case study in coastal Kenya (Kwale County) where Plan International is working with local stakeholders. The limitations of the study and recommendations for similar interventions are also shared.

## **Context: Kenya and Kwale**

The blue economy is a relatively new concept that promotes better management of the oceans and coastal resources and includes all economic activities related to oceans, seas, and coastal areas. As Kenyan national and local government departments are now recognizing the growth potential of the blue economy, it is important to understand how biodiversity and ecosystem service loss, climate change, and poverty intersect with this. According to the Kwale County Integrated Development Plan (Kwale County Government 2018), the blue economy demonstrates a potential for growth that could positively impact on peoples' income levels and contribute to climate change adaptation and mitigation outcomes in the coming years. This potential can only be achieved by investing in fisheries, improved regulations, ocean monitoring and surveillance, coastal protection, and improved waste management (Kwale County Government 2018), and it should be assessed through a people-centered approach that looks at the local challenges and linkages across the triple crisis.

As in most contexts, men and women, girls and boys, experience and respond to challenges differently – this includes natural resources, social structures, and physical environment. Women and girls relate to forests, rivers, and land differently than men (Kimani and Kombo 2010). Gender considerations are included in more recent Kenyan government policy (Republic of Kenya 2018), but the link between gender and climate change and, to a lesser extent, environmental considerations is still not well established despite an understanding the unequal impact climate change has on women and girls and their adaptation capacity. Likewise, child protection risks are starting to be understood in economic activities in Kwale – with the fishing sector and tourism being self-identified by children as being among the most harmful to them. The “sex-for-fish” phenomenon – which refers to the practice by which poor and vulnerable women and young women fish processors and traders are at risk of being coerced into sex in order to buy and/or sell fish products – has been widely reported over the past few years and remains an issue in Kwale County (Nyawade et

al. 2019). This practice (alongside the sex trade) often affects underage boys and girls, some of whom are at risk of being victims of human trafficking (IOM 2018), and has been identified as one of the harmful consequences of poverty and a lack of income-generating activities (UNICEF and the Government of Kenya 2006). There is also increased reporting of children being forced to drop out of school and co-opted into mangrove cutting, charcoal production, and agricultural activities for household and community income generation (Nyawade et al. 2019).

Fisheries research, management, and policy have traditionally focused on direct, formal, and paid fishing activities that are often dominated by men, ignoring roles performed by women that are indirect, informal, and/or unpaid (Harper et al. 2017). Indeed, the economic activities related to fisheries value chains are still very much determined by the traditional gender division of labor, power, and the patriarchal system of male dominance (Kizito et al. 2017). The gendered labor pattern concentrates production in hands of men with women at the periphery of postharvest processing and retailing. The role of women is largely marginalized to *fish mummies* or *mama karanga* in terms of resources and training (Nyawade et al. 2019). In Kenya, *mama karanga* is the name given to women who buy fish from fishermen, process the fish (usually through deep frying it), and sell it in their local communities or those nearby. Women report that they engage in this activity due to the lack of alternative income-earning options as the work does not require much education and skills, and although the barriers to entry are low, the profit margins are also very small (Matthews et al. 2012).

The case study for this chapter draws on Plan International's experience of working in Kwale County in Southeast Kenya. Situated along the southernmost Kenya coast and bordering Tanzania, Kwale County is divided into 4 constituencies and 20 county assembly wards. The total population of Kwale County was estimated at 820,199 (397,841 of which were males and 422,358 were females) in 2017 and is projected to rise to 909,929 in 2022. The County is one of the poorest, and youngest, in Kenya: as of 2013, 48% of the population of Kwale County was 0–14 years old, and the poverty rate was 71% (UNICEF 2013) – with high levels of unemployment or underemployment (30% of the total labor force between 15 and 64) (Kwale County Government 2018). In coastal communities, the population is exposed to rapid-onset weather-related events such as flash floods and slow-onset ones such as rising temperatures, recurrent droughts, rising sea levels, land and forest degradation, and loss of biodiversity. The economy in Kwale is highly sensitive to its climate, with water, agriculture, forestry, health, and tourism among the most affected sectors by weather and climate extremes (Ngaruiya et al. 2018).

Coastal communities suffer from high-income inequality, and fishing communities are highly impoverished. Artisanal fishers earn around \$3–4/day and retain some of the fish catch to take home as food. Low economic returns have contributed to the emergence of destructive fishing practices to reef habitats and fishery resources (Global Coral Reef Monitoring Network 2017). Outside of the four marine parks (fully protected) and six marine reserves (partially protected), fishing has been difficult to regulate. Beach Management Units (BMUs), established under The National Kenyan Fisheries Act of 2007, were introduced in order to provide

increased community participation in inshore marine management. This relatively new initiative still has a way to go and requires additional support in areas of reporting, record-keeping, financial sustainability, resources, and cooperation (SmartFish 2011). The lack of resources and pursuit of short-term goals prevalent in most fishing communities means that harmful practices persist.

Kwale County has suffered from significant deforestation over the past few decades: since 2000, the county has witnessed the loss of 20% of tree cover. Local communities engage in tree cutting for a myriad of reasons: agricultural expansion, rapidly growing populations, charcoal production, overreliance on wood energy, and, to a lesser extent, mining – exacerbated by weak governance (Ministry of Forestry and Wildlife 2013). Deforestation contributes to soil erosion by water, wind, and activities associated with land-use change, increasing soil degradation, and water resource loss and exposes vulnerable populations to the more extreme climate and weather events. Likewise, mangrove forests have been subject to alarming levels of destruction in Kwale over the past few decades – generally for firewood and pole production despite their importance to the region's biodiversity. According to the 2017 National Mangrove Ecosystem Management Plan, the mangroves of Kwale County comprise Vanga-Funzi, Gazi Bay, and Ukunda areas covering an area of approximately 8354 ha, with 3725 ha (45% of the area) of mangroves requiring rehabilitation.

Mangrove destruction results in a decreasing amount of coastal wood, fish and prawn stocks, shoreline erosion, storm surges, and eventual reduction of seagrass and coral reefs, which could have a damaging effect on coastal livelihoods and tourism. Recent government initiatives are promoting reforestation activities, and carbon offsetting provides direct financial incentives for tree planting alongside the indirect benefits of greater forest and mangrove cover.

Kenya has been at the forefront of climate change strategy development and launched the National Climate Change Response Strategy (NCCRS) in 2010 and the National Climate Change Action Plan (NCCAP 2013–2017) in 2013 and submitted its intended nationally determined contributions (INDC) in 2016. Specifically, in Kwale County, historical records indicate a significant increase in average temperatures over the past 20 years, with the number of heat- and drought-stressed days expected to continue to increase under future climate projections. At the same time, extreme precipitation is expected to become more frequent (MoALF 2016).

Over the past couple of decades, the Kenyan government has developed a raft of policies and legislation addressing poverty, environment, and climate change. The 1999 Environmental Management and Coordination Act (EMCA) provided the foundation for Kenya's first framework environmental law – the National Environmental Policy – launched in 2013. The Poverty Environment Initiative (a joint UNDP-UNEP program launched in 2005 in nine countries, including Kenya) began to detail the poverty-environment nexus and suitability of using economic valuation of environmental and natural resources. Likewise, Kenya's National Environmental Policy in 2013 referenced poverty, climate change, and environment in its situational analysis – although it was yet to draw on the triple crisis as interconnected factors. In the past few years, national policies and frameworks

have addressed specific components of Kenya's environmental policy, the 2005 Forests Act for preparation of management plans for all gazetted forests, the National Climate Change Framework Policy of 2016, and the National Mangrove Ecosystem Management Plan of 2017, which provides a road map toward sustainable management of mangrove ecosystems in Kenya for enhanced livelihoods and climate regulation.

---

## **Conservation and Sustainable Management of Marine Ecosystems in Kwale County Project**

In 2016, Plan International Kenya and Plan International UK developed the *Conservation and Sustainable Use of Marine Ecosystems in Kwale County* project – from now on referred to as the COSME project – as a response to a lack of viable income-generating activities, increasing environmental degradation, climate threats, and dwindling fishing returns along the southernmost coast of Kwale County. The project aimed to improve the lives – and livelihoods – of coastal communities, particularly women, through participatory and sustainable development (including the introduction of diversified responsible economic opportunities), promoting environmental conservation and management of environmental risks and increasing resilience to climate-related extremes. The project activities formally started in January 2017 and closed in May 2019, with the final evaluation finalized in June 2019. An ex-post-evaluation exercise was conducted in February–April 2020.

The COSME project mobilized groups in the Lunga Lunga and Msambweni constituencies and reached the community groups listed in Table 1.

Overall, the COSME project reached 4145 people (1440 directly and 2705 people indirectly).

In partnership with the Kenya Marine and Fisheries Research Institute (KMFRI), the project sought to introduce improved and environmentally sustainable fishing techniques and promote alternative and supplementary income-generating activities (seaweed farming being the most prominent and successful intervention) among communities heavily reliant on the fishing economy – and alleviate the pressures on the stressed fishing waters. The activities were informed by research into current and alternative livelihood practices, the viability of local fisheries, and child protection and gender dynamics in the local coastal economy.

Interventions also included awareness raising and education in local schools and communities aiming to increase knowledge and capacity around natural resource management and environmental protection – particularly focusing on the impacts of illegal forest cutting, mangrove destruction, and unsustainable fishing practices. As referenced previously, engaging in illegal practices and natural resource degradation are partially a result of negative coping mechanisms of community members and fishing groups when the returns from fishing are inadequate. With technical support from the Kenya Forestry Service (KFS), the project worked with schools and community-based organizations to promote tree and mangrove seedling production with the long-term goal of encouraging a rejuvenation of fish stocks, reestablishing

**Table 1** Project communities and community group by main initiative

Group	Number of groups	Names
Responsible fishing	10	Gazi
		Chale Jeza
		Mgwani
		Mwandamo
		Nyumba Sita
		Bodo
		Mwazaro
		Kibuyuni
		Majoreni Aleni
		Mkuphani
Mangrove forest regeneration	4	Shangani-Amani self-help group
		Mwazaro Beach Management Unit
		Bodo Beach Management Unit
		Cheichakale self-help group
Seaweed farming	3	Shangani-Amani self-help group
		Tujuane seaweed farmers
		Imani seaweed farmers
Terrestrial tree planting	4	Mkanda Primary School group
		Lukore Primary School group
		Jirani charcoal producers
		Mkurumudzi

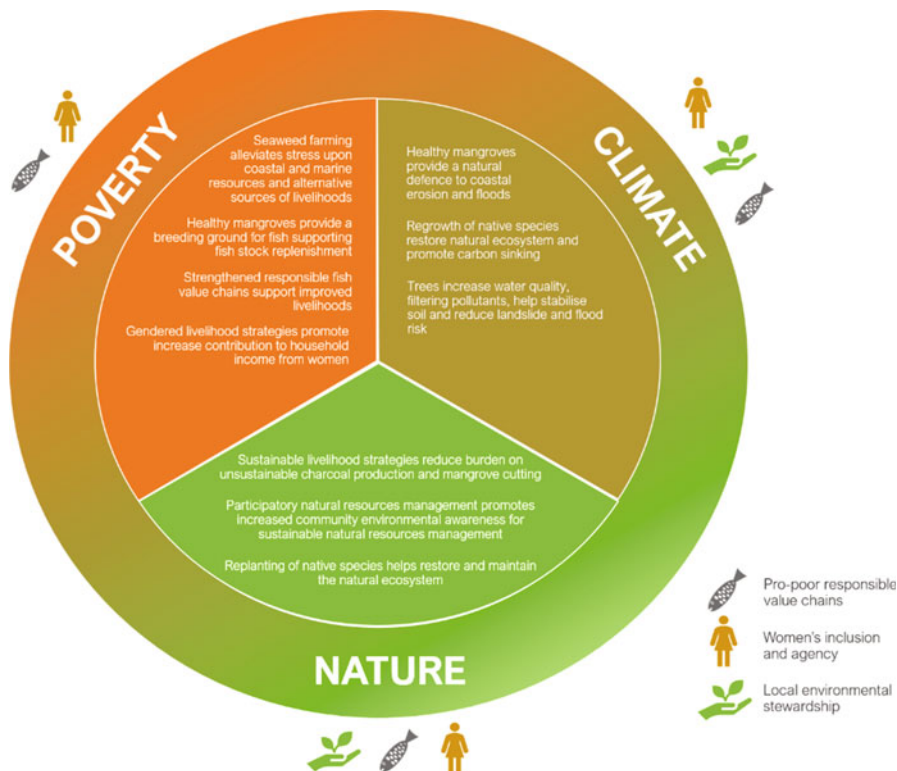
natural defenses against flooding, and promoting soil and water resource management.

## A People-Centered Approach to Address the Triple Crisis at Local Level

Figure 1 illustrates the integrated people-centered approach developed and used in the COSME project (2017–2019) to bring together actions that seek to address climate, nature, and poverty issues at the local level.

In the diagram, the main activities of the project and their contributions are listed at the center of the pie, under the domain of the main challenge they explicitly aim to tackle. The integrated nature of the project means that subsidiary results of the activities will contribute to addressing other challenges and was a key project goal. The diagram also identifies the components of the approach that promote community ownership and leadership, facilitated through engagement with self-managed community groups. Those components have been grouped under three categories, represented in the diagram using icons: (i) local environmental stewardship, (ii) women's inclusion and agency, (iii) pro-poor responsible value chain development. The emphasis placed on the role of local communities in catalyzing social,





**Fig. 1** People-centered approach to address the triple crisis in coastal Kwale County, Kenya. (Adapted from WWF-UK 2018)

economic, and ecological transformation is central to the approach – promoting ownership of local natural capital and transparency in its management while valuing and strengthening traditional knowledge and ability to identify solutions. Local communities are critical to the design and implementation of interventions due to their wealth of knowledge and experience in dealing with localized climate and ecological risks and their role as long-term stewards of natural resources. Local ownership is also central to ensuring long-term sustainability and scale-up of the project interventions.

### Local Environmental Stewardship

Local environmental stewardship is defined as the sum of the actions taken by individuals, groups, or networks of actors, with various motivations and levels of capacity, to protect or responsibly use the environment in pursuit of environmental and/or social outcomes (Bennett et al. 2018).

Restoration of local natural capital, particularly in the form of mangrove ecosystems, which has been emphasized as one of the planet's most efficient carbon sequestration ecosystems, helps mitigate the risks of coastal erosion and coastal floods and promote breeding grounds for local fish species (Kumar 2019).

Over the years, illegal logging, charcoal production, encroachment of forested areas, overgrazing, and other human activities have all contributed to forest loss and degradation. Along the Kwale coast, mangrove forest has been degraded and overexploited primarily for timber and firewood from within and outside the communities. In Kwale County, most of the mangrove forest are currently found in the Shimoni-Vanga area where a number of successful community-based conservation initiatives have been established, notably the Mikoko Pamoja project in Gazi.

Led by coastal community mangrove groups and tree planting groups in the upstream communities, the COSME planting activities have returned increasing yields in terms of numbers of trees growing and their survival rate. Over the 2-year period, 127 people across 4 groups, of which 50% members are women, planted 137,000 seedlings of mangroves, with an additional 56,000 since the project formally closed. Additionally, 820 (women, girls, boys, and men – with a 50% female participation rate) have planted 7940 seedlings for reforestation of fruit-bearing trees, native forest species, and sustainable charcoal replacement trees. Although there has been some attrition rate with seedlings being lost at the project start due to poor management, the survival rate has subsequently grown and stabilized at 80% on average. In addition to this, one of the groups – a charcoal cooperative – involved in tree production and planting has decided to cease with charcoal production all together and is now focusing their income-generating activities on goat-rearing and beekeeping. The group is now hoping to work with the local government partners to identify and receive further training on additional alternative and sustainable income-generating activities.

Community groups have shown a high level of understanding of the relevance of the activities, the expected positive ecological and disaster risk reduction outcomes, and the beneficial effects resulting on their well-being and livelihoods. Since project closure, 80% of the groups continue to be active. Additionally, a number of mangrove groups have, independent of the project, started to engage in money-saving practices through village savings schemes to invest in project-related activities. Individuals contribute funds which have been used to secure formal registration of the savings group, which will allow the group to access additional funds and purchase products to continue and expand operations – including signs to identify the sites under rehabilitation, seedling inputs, record-keeping material, and a boat to reach the areas under rehabilitation. The engagement of fisherfolk through the community BMUs and mangrove groups has been critical to ensuring commitment from the wider community demonstrating the beneficial effects of a healthy mangrove forest for the local economy and livelihoods. These activities have been complemented with sensitization on the negative effects of illegal fishing practices, particularly the use of explosives, seine nets, and poison. Orientating fishing groups around destructive fishing practices that have a degrading effect on the ecological balance of the reef and the seafloor has been complemented by the promotion of

responsible fishing techniques which contribute to long-term environmental benefits attached to a key economic activity.

## Women's Inclusion and Agency

Gender consideration is particularly important in coastal communities as (i) the responsible management and use of marine and coastal resources can offer an important entry point and opportunity for women's economic and social empowerment, alongside strengthening resource governance and conservation, and (ii) gender-based violence (GBV) is a specific concern in the fisheries sector (Siles et al. 2019). FAO estimates that women directly engaged in some form of primary fishery production account for more than 15% of the people engaged in fisheries and aquaculture, with 90% of those engaged in processing activities. However, while women often play significant roles both in the fisheries value chain and in providing support to the organization – e.g., repairing fish nets, processing, and marketing fish – they often have limited decision-making power and tend to be absent from leadership positions (FAO 2016a). Additionally, failure to engage women in management efforts, coupled with women's prominent roles as environmental stewards, results in lost opportunities to improve conservation practices and sustainably manage natural resources upon which these communities' livelihoods depend. Integrating gendered considerations into conservation and development interventions increases the likelihood that they will achieve targeted outcomes of poverty alleviation and improved food security in coastal communities (Matthews et al. 2012).

Findings from the project highlighted high vulnerability of women and girls to GBV, particularly exacerbated by decreasing fishery resources – women and girls are at greater risk of GBV from fish sellers and traders in order to be able to sell or purchase fish (Siles et al. 2019). Women reported supplementing the household income through activities such as soap-making, animal husbandry, farming, and selling firewood.

Through analysis of the women's unique contribution to the local economy, their capacities, needs, and constraints placed upon them, the project has identified strategies to better involve women and uphold women's interests at varying stages of the intervention.

The project was largely successful in reaching women and girls through awareness-raising and education initiatives – where they have been prominently involved in promoting reforestation activities and in-school education. Further to this, women have been supported and have strongly engaged in seaweed farming and the monitoring, management, and promotion of environmental conservation activities. The project evaluation also found reports of improvement on issues related to children and girls' welfare at the local level, including a reduction in reported cases of child trafficking, a reduction in reported child pregnancy among fishing communities, a reduction in girls dropping out of school to engage in fish processing and marketing, a reduction of children (especially boys) dropping out of school to

engage in local touristic activities, and a reduction of children supporting parents in boat and local furniture production and in mangrove harvesting.

## **Pro-poor Responsible Value Chain Development**

Value chain development refers to extending or improving the productive operations of a value chain and generating social benefits – e.g., poverty reduction, income and employment generation, economic growth, environmental performance, and gender equity (UNIDO 2011). A value chain refers to the full range of activities that are required to bring a product, or a service, from conception through production, delivery to final consumers, and disposal after use. Pro-poor value chain initiatives often try to overcome entry barriers for poor producers to inputs and services, including technical capacity, and help them gain access to output markets.

As part of the project, research activities were conducted to investigate feasible alternative livelihood activity (a completely different occupation from the usual primary occupation practiced by the individual household), supplemental livelihood activities (a portfolio of activities that are added to and complement the usual primary occupation practiced by the individual household), and strategies and barriers that stop income diversification within coastal households. As part of the research, extensive consultations were held with key actors, including community members, KMFRI, and other relevant local government agencies. Researchers reported that discussions on alternative livelihoods are not straightforward with fishing groups, referencing that fisherfolk “will continue to fish till the last fish species is caught” (Nyawade et al. 2019). Identifying sustainable livelihood options in co-participation with the local communities, therefore, was one of the main objectives of the COSME project.

Findings from the research study reported a declining trend in fish productivity and diversity, and a low level of income diversification among coastal community households. That led to an increase in vulnerability to climate-related, idiosyncratic, and economic stresses. Willingness and readiness to diversify to supplemental and enhanced livelihoods, rather than alternative livelihoods, has been indicated as preferential by the interviewed households (Nyawade et al. 2019). As part of this exploration into income diversification, the COSME project explored opportunities to decrease gender inequalities within the household and community – to ensure that unequal power relations between men and women did not negatively impact diversification activities. Likewise, assessing, and adapting interventions that address the roles men, women, girls, and boys play in the value chain, contributes to increased household income that is increasingly more resilient to economic and climate risks.

Seaweed farming emerged as one of the preferred supplemental livelihoods. With that in mind, the Kenya Coastal Development Project (KCDP), a World Bank project that set up the Kibuyuni seaweed farmers association and individual seaweed farms in Kibuyuni, offered insights on the viability of the businesses and value chain market.

Historically, seaweed farming was considered “not [to be] a major livelihood and is mainly left for the women to perform,” according to respondents from a male focus group discussion.

Seaweed farming is characterized by low barriers to entry and low risk for the poor while being particularly promising in its potential for scaling up across the communities. Seaweed farming provided an opportunity for the women to exploit the blue economy and meaningfully contribute to household earnings. In the last year of implementation, however, the COSME project has seen an increase in popularity of seaweed farming among men. This will need to be closely monitored and managed to ensure that seaweed value chains do not start to reflect the gender disparity witnessed in fishing value chains.

The initial cost of investment is very small, with only a few tools needed – e.g., ropes, footwear, knives – and a growing cycle of roughly 45 days. On average seven cycles are expected per year with a productivity of 600 kg on average per cycle as reported by the interviewed group members. Since October 2018, the seaweed farmers have been selling to a single buyer for 25 KES/kg.

Among the communities, there is a supportive environment for seaweed farming and interest to expand their operations. One seaweed farming group was able to leverage public investment from the county government for the construction of a seaweed drying and processing facility, which is under planning. The end-line survey revealed that women participating in seaweed farming had increased their base of consumer and household assets. During focus group discussions, some women stated that they had used some of the additional seaweed income to purchase land and build permanent houses (a rare phenomenon before the COSME project in the local communities) and to pay school fees and medical expenses, and a number of female seaweed farmers have shown an interest in possibly expanding their farms.

---

## Findings and Recommendations

The 2-year-long COSME project has shown encouraging results and demonstrated some positive outcomes that address poverty-, climate-, and nature-related issues. Experiential knowledge, monitoring reports, case studies, final qualitative evaluation, and a research exercise underpin the conclusions and recommendations for future initiatives and are shared here for consideration:

- While the ability – and appetite – to save income has sporadically been recorded in a number of community groups reached by the project activities, it has always been through independent actions and not formally facilitated by the project activities. Interviewed group members reported limited knowledge and increased desire to engage in community-level saving and loan schemes to reinvest capital to expand their businesses and increase their asset base. Financial literacy skills development and village savings and loan association (VSLA) schemes could offer a secure saving facility and access to loans to be reinvested into the family or group businesses, as well as to absorb any shocks the household may face.

- Seaweed farming has proved a viable and sustainable option, particularly successful in increasing economic and social empowerment of local women. Women have reported feeling proud to be able to contribute to the household needs and able to use the profits to purchase food for the family. Due to increased interest from men, it's critical to manage any potential conflict that might arise due to an increased product offer as well as the competition with other coastal users for surface area needed to develop viable operations.
- A lack of a ready market to sell harvested seaweed and tree seedlings from the nurseries set up in the upstream communities proved challenging during the project. It's important to identify any existing and foreseeable constraints to sustainable income-generating opportunities to ensure uptake in the long term is achievable. A detailed and contextualized value chain analysis, including buyers, distribution, and consumption markets for seaweed, particularly exploring monopsony (a situation in the market where there is only one buyer for a given product who is able to determine prices and exert power over sellers) power that could affect market prices, is advised.
- A number of seaweed farms had to be moved to new coastal locations less exposed from the impacts of storm surges and heavy rains. A feasibility study and coastal mapping in the design phase of the project would help identify those locations at a lower risk of weather hazards.
- Gender inclusion in the value chain promotes women's empowerment and increases their contribution to household income. At the end of the COSME project, women reported investing their earning in paying for their children's school fees and health-related expenses and improving their quality of life (e.g., safe water access, house improvements) with clear outcomes for the wider household and community, including household-level risk diversification, children's well-being, and a shift to more sustainable livelihoods. Based on the importance of women's roles in the coastal economy, their inclusion in the sustainable development of value chains should be promoted through addressing gender issues, community dynamics, and cultural norms and systematically examine gender-based constraints that prevent them from accessing the same opportunities as men. An increase understanding of vulnerabilities, including those to climate-related shocks and stresses, should also be sought.
- GBV prevention training and sensitization at community level and for relevant local authorities may help address the risk of GBV in coastal communities and promote preventive action. Likewise, any technical or advocacy training should include a strong gender mainstreaming thread.
- Robust environmental monitoring and data collection activities – e.g., monitoring of restored areas of forest using geographical information systems, geocoordinates, and monitoring of fish catch species and amounts and fish sold – particularly involving women, should be encouraged to improve information transparency and decision-making at community and local level.
- Anecdotal evidence of more frequent occurrence of dry spells and shortening of the rainy season has been reported from within the communities and matches

county-level historical records. Alternative and supplemental livelihood strategy diversification implemented through the COSME project has the power to enhance the ability to withstand climate and economic risks. To better understand their contribution to household-level climate resilience, initial analysis aimed to identify the drivers of household climate resilience should be conducted at the start of the initiative. Climate shocks and stresses that individuals, households, communities, and larger systems are exposed to, and the severity and duration of these, should also be analyzed to enable a more robust measurement of household-level climate resilience.

- Worldwide, payments for environmental services (PES) have been identified as a viable income-generating option with major potential to promote sustainable ecosystem management and forest conservation (FAO 2016b). Learning from existing payment schemes for ecosystem services in Kwale – e.g., Mikoko Pamoja in Gazi – should be facilitated, and the possibility for increasing participating households’ earnings through selling carbon credits should be explored with the potential of improving environmental outcomes, specifically through the increase in carbon stock trading.
- Local government engagement is particularly important to ensure that continued technical support and innovation are promoted to local groups and new approaches and learnings are informing policy, regulatory, and legal changes. Civil society and local government partners are working together to provide a much stronger, coherent approach to natural resource management and environmental stewardship and opportunities for learnings and best practice to be shared more widely.
- Waste management needs to be explicitly incorporated into environmental and conservation activities. Increasing levels of plastic waste is affecting mangroves and fisheries; therefore targeting beach clearing and education among upstream communities, as well as coastal communities, regarding waste disposal is strongly advised.

## Limitations of the Study

While the project has yielded promising results in addressing the triple crisis at the local level, it’s important to note that the limited duration in formal project activities meant only limited short-term outcomes were measured by the project closure. Additionally, the narrow geographical extent and scale of the project mean the initiative remains limited in scope. Likewise, the relatively small population sample the project reached, and the corresponding qualitative methods used in the research, means that any causality to positive change needs to be understood within these restrictions. While the team is confident in linking those positive results directly to project interventions, it does consider attribution with caution, and an ex-post-evaluation is in process to better understand the contributions of the initiatives to the recorded outcomes.

## Conclusions

In recent years, the triple crisis concept has emerged in response to the acknowledgment that climate change, degradation of nature, and poverty are fundamentally interdependent of each other and among the biggest global challenges.

The proposed people-centered approach developed under the COSME project draws from previous publications and research and attempts to address the triple crisis at the local level. The study specifically looks at those components that promote community ownership and leadership in order to catalyze social, economic, and ecological transformation at the local level. The central role women play with regard to natural resource management and coastal economies has been recognized. Understanding gendered dynamics of environmentally minded interventions and strengthening their decision-making and leadership capabilities and providing them with the skills and knowledge to meaningfully participate in coastal economy value chains could have a multiplying co-benefit on future initiatives.

While the study has been limited due to the geographical scope and size of the project, encouraging results have been recorded in relation to the ability of the communities to respond to climate risks, promote environmental stewardship, and enhance their household economic empowerment.

Initial findings are discussed, and recommendations for similar initiatives have been shared. Furthermore, an ex-post-evaluation is currently in progress and expected to be completed in the first half of 2020 that will focus on the medium-term outcomes of the project through the triple crisis lens.

**Acknowledgment** This work was funded through the Future Plan Fund, a Plan International UK programme supported by an anonymous donor with initiatives in Kenya, Colombia, and East Timor.

---

## References

- Barbier E, Hochard JP (2018) Poverty, rural population distribution and climate change. *Environ Dev Econ* 23(3):234–256
- Bennett NJ, Whitty TS, Finkbeiner E, Pittman J, Bassett H, Gelcich S, Allison EH (2018) Environmental stewardship: a conceptual review and analytical framework. *Environ Manag* 61(4):597–614
- Boone RB, Conant RT, Sircely J, Thornton PK, Herrero M (2018) Climate change impacts on selected global rangeland ecosystem services. *Glob Chang Biol* 24(3):1382–1393
- CBD (Conference of the Parties to the Convention on Biological Diversity) (2018) Biodiversity and climate change. Available [go.nature.com/2SJPzkc](https://www.nature.com/2SJPzkc)
- EC (European Commission) (2018) Nature-based solutions. Available <https://ec.europa.eu/research/environment/index.cfm?pg=nbs>
- FAO (2016a) The State of the World's Fisheries and Aquaculture 2016: contributing to food security and nutrition for all. Rome. Available <http://www.fao.org/3/a-i5555e.pdf>
- FAO (2016b) Payments for forest environmental services in sub-Saharan Africa: a practical guide. In: Nantongo P. Accra. Available <http://www.fao.org/3/a-i5578e.pdf>
- Global Coral Reef Monitoring Network (2017) Coral reef status report for the Western Indian Ocean. Mauritius. Available [https://wedocs.unep.org/bitstream/handle/20.500.11822/28371/Coral\\_Reef\\_2017.pdf?sequence=1&isAlloyouy](https://wedocs.unep.org/bitstream/handle/20.500.11822/28371/Coral_Reef_2017.pdf?sequence=1&isAlloyouy)



- Gosling SN (2013) The likelihood and potential impact of future change in the large-scale climate-earth system on ecosystem services. *Environ Sci Pol* 27(1):S15–S31
- Hansen J, Hellin J, Rosenstock T, Fisher E, Cairns J, Stirling C, Lamanna C, van Etten J, Rose A, Campbell B (2019) Climate risk management and rural poverty reduction. *Agric Syst* 172:28–46
- Harper S, Grubb C, Stiles M, Sumaila UR (2017) Contributions by women to fisheries economies: insights from five maritime countries. *Coast Manag* 45(2):91–106
- Hoegh-Guldberg O, Jacob D, Taylor M, Bindi M, Brown S, Camilloni I, Diedhiou A, Djalante R, Ebi KL, Engelbrecht F, Guiot J, Hijioka Y, Mehrotra S, Payne A, Seneviratne SI, Thomas A, Warren R, Zhou G (2018) Impacts of 1.5°C global warming on natural and human systems. In: Masson-Delmotte V, Zhai P, Pörtner HO, Roberts D, Skea J, Shukla PR, Pirani A, Moufouma-Okia W, Péan C, Pidcock R, Connors S, Matthews JBR, Chen Y, Zhou X, Gomis MI, Lonnoy E, Maycock T, Tignor M, Waterfield T (eds) *Global warming of 1.5°C. An IPCC special report on the impacts of global warming of 1.5°C above pre-industrial levels and related global greenhouse gas emission pathways, in the context of strengthening the global response to the threat of climate change, sustainable development, and efforts to eradicate poverty*. [Masson-Delmotte, V., P. Zhai, H.-O. Pörtner, D. Roberts, J. Skea, P.R. Shukla, A. Pirani, W. Moufouma-Okia, C. Pean, R. Pidcock, S. Connors, J.B.R. Matthews, Y. Chen, X. Zhou, M.I. Gomis, E. Lonnoy, T. Maycock, M. Tignor, and T. Waterfield (eds.)]. In Press.
- Howe C, Suich H, van Gardingen P, Rahman A, Mace GM (2013) Elucidating the pathways between climate change, ecosystem services and poverty alleviation. *Curr Opin Environ Sustain* 5(1):102–107
- Hutchison J, Spalding M, zu Ermgassen P (2014) The role of mangroves in fisheries enhancement. The Nature Conservancy and Wetlands International, Cambridge. Available <https://www.conservationgateway.org/ConservationPractices/Marine/crr/library/Documents/The%20Role%20of%20Mangroves%20in%20Fisheries%20Enhancement.pdf>
- IOM (2018) Assessment report on the human trafficking situation in the coastal region of Kenya, Nairobi. Available [http://kenya.iom.int/sites/default/files/ASSESSMENT%20REPORT%20ON%20HUMAN%20TRAFFICKING%20SITUATION%20-%20-%20COASTAL%20REGION%20KENYA%20REVISED%20LOWRES%2023072018%20F\\_0.pdf](http://kenya.iom.int/sites/default/files/ASSESSMENT%20REPORT%20ON%20HUMAN%20TRAFFICKING%20SITUATION%20-%20-%20COASTAL%20REGION%20KENYA%20REVISED%20LOWRES%2023072018%20F_0.pdf)
- IPBES (2019) Summary for policymakers of the global assessment report on biodiversity and ecosystem services of the Intergovernmental Science-Policy Platform on Biodiversity and Ecosystem Services. IPBES Secretariat, Bonn. Available [https://ipbes.net/system/tdf/ipbes\\_7\\_10\\_add.1\\_en\\_1.pdf?file=1&type=node&id=35329](https://ipbes.net/system/tdf/ipbes_7_10_add.1_en_1.pdf?file=1&type=node&id=35329)
- IUCN (2017) Mangroves: nurseries for the world's seafood supply. Available <https://www.iucn.org/news/forests/201708/mangroves-nurseries-world%E2%80%99s-seafood-supply>
- Kimani EN, Kombo DK (2010) Gender and poverty reduction: a Kenyan context. *Educ Res Rev* 5(1):24–30
- Kizito P, Kimani E, Lodiaga MJA (2017) Socio-economic determinants of men and women's participation in fisheries value chain in Nairobi City County, Kenya. *J Sci Eng Res* 4(4):91–98
- Kumar P (2019) Nature-based solutions: the missing ingredient in climate adaptation?. <https://blogs.ei.columbia.edu/2019/06/28/nature-based-solutions-climate-adaptation/>
- Kwale County Government (2018) Kwale county integrated management plan 2018–2022. Kwale. Available <https://bit.ly/32IqN9c>
- Leichenko R, Silva JA (2014) Climate change and poverty: vulnerability, impacts, and alleviation strategies. *WIREs Clim Chang* 5(4):539–556
- Lo V (2016) Synthesis report on experiences with ecosystem-based approaches to climate change adaptation and disaster risk reduction. Technical series no. 85. Secretariat of the Convention on Biological Diversity, Montreal, p 106. Available <https://www.cbd.int/doc/publications/cbd-ts-85-en.pdf>
- Matthews E, Bechtel J, Britton E, Morrison K, McClennen C (2012) A gender perspective on securing livelihoods and nutrition in fish-dependent coastal communities. Report to The Rockefeller Foundation from Wildlife Conservation Society, Bronx
- McIvor AL, Spencer T, Möller I, Spalding M. (2013) The response of mangrove soil surface elevation to sea level rise. Natural coastal protection series: report 3. Cambridge Coastal Research Unit working paper 42. Published by The Nature Conservancy and Wetlands

- International. Available <http://coastalresilience.org/science/mangroves/surface-elevation-and-sea-level-rise>
- MEA (Millennium Ecosystem Assessment) (2005) Ecosystem and human well-being synthesis. Island Press, Washington, DC. Available <https://www.millenniumassessment.org/documents/document.356.aspx.pdf>
- MoALF (2016) Climate risk profile for Kwale County, Kenya County climate risk profile series. The Ministry of Agriculture, Livestock and Fisheries (MoALF), Nairobi
- Munang RT, Thiaw I, Rivington M (2011) Ecosystem management: tomorrow's approach to enhancing food security under a changing climate. *Sustainability* 3:937–954
- Murdiyarto D, Purbopuspito J, Kauffman JB, Warren MW, Sasmito SD, Donato DC, Manuri S, Krisnawati H, Taberima S, Kurnianto S (2015) The potential of Indonesian mangrove forests for global climate change mitigation. *Nat Clim Chang* 5:1089–1092
- Ngaruiya G, Oremo F, Ochieng B (2018) Devolving climate change governance in Kwale County, Kenya. Devolution of climate change guide. ILEG, Nairobi
- Nyawade BO, Okeyo-Owuor JB, Were PK, Paul JO (2019) Drivers and barriers for adoption of alternative environmentally sustainable livelihood options among coastal communities of Kwale, Kenya. Plan International Kenya, Nairobi. Unpublished
- People and Nature Campaign (2019) Available [peopleandnature.co.uk](http://peopleandnature.co.uk)
- Reid H, Swiderska K (2008) Biodiversity, climate change and poverty: exploring the links. IIED, London. Available <https://pubs.iied.org/pdfs/17034IIED.pdf>
- Republic of Kenya (2018) Submission by Kenya to SBI 48 on gender and climate change: A2 (capacity building) and E1 (monitoring and evaluation). Available [https://www4.unfccc.int/sites/SubmissionsStaging/Documents/201805051028%2D%2D-Kenya%20Submission%20on%20Gender%20and%20Climate%20Change\\_25th\\_April\\_2018.pdf](https://www4.unfccc.int/sites/SubmissionsStaging/Documents/201805051028%2D%2D-Kenya%20Submission%20on%20Gender%20and%20Climate%20Change_25th_April_2018.pdf)
- Siles J, Prebble M, Wen J, Hart C, Schuttenberg H (2019) Advancing gender in the environment: gender in fisheries – a sea of opportunities. IUCN and USAID. USAID, Washington, DC
- SmartFish (2011) IRFS Kenya fisheries governance. Available <http://www.fao.org/3/a-az379e.pdf>
- Temmerman S, Meire P, Bouma TJ, Herman PMJ, Ysebaert T, De Vriend HJ (2013) Ecosystem-based coastal defence in the face of global change. *Nature* 504:79–83
- Turner WR, Brandon K, Brooks TM, Gascon C, Gibbs HK, Lawrence KS, Mittermeier RA, Selig ER (2012) Global biodiversity conservation and the alleviation of poverty. *Bioscience* 62(1):85–92
- UNEP (2016) Loss and damage: the role of ecosystem services. United Nations Environment Programme, Nairobi. Available [https://collections.unu.edu/eserv/UNU:5614/loss\\_and\\_damage\\_meta.pdf](https://collections.unu.edu/eserv/UNU:5614/loss_and_damage_meta.pdf)
- UNICEF (2013) Kenya, Kwale County. Available [https://www.unicef.org/kenya/KWALE\(1\).pdf](https://www.unicef.org/kenya/KWALE(1).pdf)
- UNICEF and the Government of Kenya (2006) The extent and effect of sex tourism and sexual exploitation of children on the Kenyan Coast, Nairobi, Kenya. Available [http://lastradainter-national.org/lsidocs/418%20extent\\_n\\_efect\\_1007.pdf](http://lastradainter-national.org/lsidocs/418%20extent_n_efect_1007.pdf)
- UNIDO (2011) Pro-Poor Value Chain Development: 25 guiding questions for designing and implementing agroindustry projects. United Nations Industrial Development Organization (UNIDO), Vienna
- van der Geest K, de Sherbinin A, Kienberger S, Zommers Z, Sitati A, Roberts E, James R (2019) The impacts of climate change on ecosystem services and resulting losses and damages to people and society. In: Mechler R, Bouwer L, Schinko T, Surminski S, Linnerooth-Bayer J (eds) Loss and damage from climate change. Climate risk management, policy and governance. Springer, Cham
- WWF-UK (2018) Avoiding triple jeopardy: developing a joined-up future for climate, food and nature. Available [https://www.wwf.org.uk/sites/default/files/2018-07/WWF\\_Avoiding\\_Triple\\_Jeopardy\\_Report.pdf](https://www.wwf.org.uk/sites/default/files/2018-07/WWF_Avoiding_Triple_Jeopardy_Report.pdf)

**Open Access** This chapter is licensed under the terms of the Creative Commons Attribution 4.0 International License (<http://creativecommons.org/licenses/by/4.0/>), which permits use, sharing, adaptation, distribution and reproduction in any medium or format, as long as you give appropriate credit to the original author(s) and the source, provide a link to the Creative Commons license and indicate if changes were made.

The images or other third party material in this chapter are included in the chapter's Creative Commons license, unless indicated otherwise in a credit line to the material. If material is not included in the chapter's Creative Commons license and your intended use is not permitted by statutory regulation or exceeds the permitted use, you will need to obtain permission directly from the copyright holder.





# Land Use Cover Types and Forest Management Options for Carbon in Mabira Central Forest Reserve

# 133

Aisha Jjagwe, Vincent Kakembo, and Barasa Bernard

## Contents

Introduction: Land Use Change and Carbon .....	2734
Mabira Central Forest Reserve: Location and Management .....	2735
Estimating Biomass and Soil Organic Carbon Stocks in Mabira CFR .....	2737
Estimating Above-Ground Biomass and Carbon Stocks .....	2737
Estimating Soil Organic Carbon .....	2740
AGB and Carbon Stocks .....	2741
Discussion .....	2744
Conclusion .....	2750
References .....	2750

## Abstract

Mabira Central Forest Reserve (CFR), one of the biggest forest reserves in Uganda, has increasingly undergone encroachments and deforestation. This chapter presents the implications of a range of forest management options for carbon stocks in the Mabira CFR. The effects of forest management options were reviewed by comparing above-ground biomass (AGB), carbon, and soil organic carbon (SOC) in three management zones. The chapter attempts to provide estimates of AGB and carbon stocks (t/ha) of forest (trees) and SOC using

---

This chapter was previously published non-open access with exclusive rights reserved by the Publisher. It has been changed retrospectively to open access under a CC BY 4.0 license and the copyright holder is “The Author(s)”. For further details, please see the license information at the end of the chapter.

---

A. Jjagwe (✉) · V. Kakembo  
Department of Geoscience, Nelson Mandela University, Port Elizabeth, South Africa  
e-mail: [aishajagwea@hotmail.com](mailto:aishajagwea@hotmail.com); [vincent.kakembo@mandela.ac.za](mailto:vincent.kakembo@mandela.ac.za)

B. Bernard  
Institute of Environment and Natural Resources, Makerere University, Kampala, Uganda  
e-mail: [barasagis@gmail.com](mailto:barasagis@gmail.com)

sampling techniques and allometric equations. AGB and carbon were obtained from a count of 143 trees, measuring parameters of diameter at breast height (DBH), crown diameter (CW), and height (H) with tree coordinates. It also makes use of the Velle (Estimation of standing stock of woody biomass in areas where little or no baseline data are available. A study based on field measurements in Uganda. Norges Landbrukshoegskole, Ås, 1995) allometric equations developed for Uganda to estimate AGB.

The strict nature reserve management zone was noted to sink the highest volume of carbon of approximately 6,771,092.34 tonnes, as compared to the recreation zone (2,196,467.59 tonnes) and production zone (458,903.57 tonnes). A statistically significant relationship was identified between AGB and carbon. SOC varied with soil depth, with the soil surface of 0–10 cm depth registering the highest mean of 2.78% across all the management zones. Soil depth and land use/cover types also had a statistically significant effect on the percentage of SOC ( $P = 0.05$ ). A statistically significant difference at the 95% significance level was also identified between the mean carbon stocks from one level of management zones to another. Recommendations include: demarcating forest boundaries to minimize encroachment, enforcement of forestry policy for sustainable development, promote reforestation, and increase human resources for efficient monitoring of the forest compartments.

---

**Keywords**

Above-ground biomass · Allometric equations · Soil organic carbon · Land use/cover change

---

**Introduction: Land Use Change and Carbon**

Representing 33% of the global land area (FAO 2011) and containing more carbon per unit area than any other land cover type (Hairiah et al. 2011), forests comprise the biggest percentage of biomass and play a big role in mitigating greenhouse gas emissions, especially carbon dioxide. According to the FAO (2010), biomass is the organic matter both above and below the ground. Forest biomass assessment is very important for national development planning, as well as scientific studies of ecosystem productivity and carbon budgets (Parresol 1999; Zheng et al. 2004). Considering climate change trends, there is a growing need for information on forest carbon stocks. Olson et al. (1983), Thornes (2002), and Schimel et al. (2001) point out that forests contain nearly 85% of the global above-ground carbon, and 40% of the below-ground terrestrial carbon stocks (Brown and Lugo 1984; Dixon et al. 1994). Land use/cover change (LUCC) has led to destruction of habitats, forests, exposed land to erosion, and affected human well-being (Foley et al. 2005; Kerr et al. 2007; Ellis and Pontius 2007; Arsanjani 2012). Alterations caused by LUCC account for the release of greenhouse gases into the atmosphere, resulting into global warming. Further effects are manifest in climate variability and change (Hashim and Hashim

2016). Studies by Watson et al. (2000), UNEP (2002), and Lambin and Geist (2008) have cautioned about instant and threatening effects of LUCC on agriculture, biodiversity, human health, and well-being. Despite its importance, accurate statistics on LUCC are not available in tropical countries (Ochoa-Gaona and Gonzalez-Espinosa 2000). Agriculture is still the most significant driver of global deforestation. Given the importance to the planet's future of both agriculture and forests, there is an urgent need to promote positive interactions between these two land uses (FAO 2016).

The rate of deforestation, estimated at 0.4–0.7% per year (Shrestha et al. 2004; Parry et al. 2007), constitutes immense environmental stress. Between 2000 and 2010, 13 million ha of world forest were lost (FAO 2010), implying an increase in the amount of carbon dioxide into the atmosphere. According to Baccini et al. (2012) and Harris et al. (2012), deforestation and forest degradation contribute about 20% of the greenhouse emissions. Land use change leads to alterations in carbon storage in soils and vegetation. Consequently, it strongly influences emissions and fixation of carbon in these ecosystems (Jandl et al. 2007). Jjagwe et al. (2017) identify the significant drivers of land use/cover changes in and around the Mabira CFR as: high household size, loss of soil fertility, poor agricultural practices, establishment of roadside markets, industrialization, and the unclear CFR boundary. Against the above background, that the main aim here is to estimate and compare total tree biomass and carbon stocks among the three management zones of the Mabira CFR.

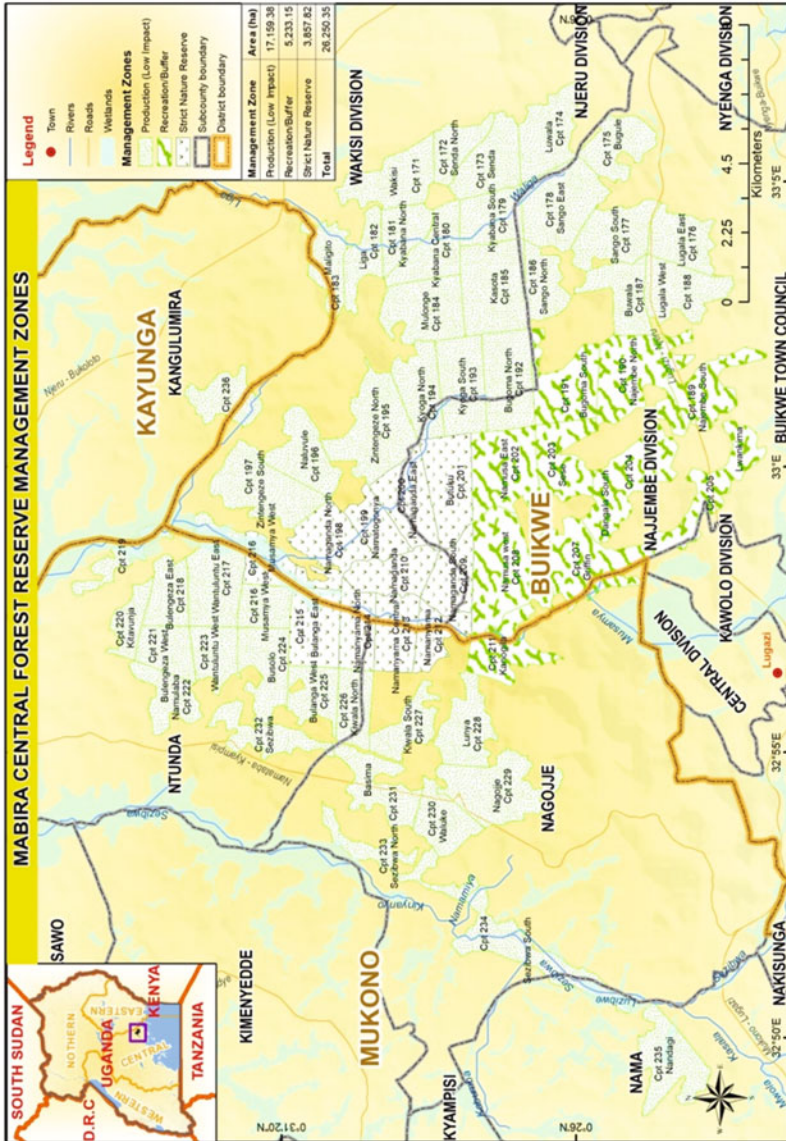
---

## Mabira Central Forest Reserve: Location and Management

Mabira Central Forest Reserve (CFR) is currently the largest natural rainforest region found in the Lake Victoria crescent of Uganda, spanning the districts of Mukono, Buikwe, and Kayunga (Fig. 1). It lies 54 km east and 26 km west of the cities of Kampala and Jinja, respectively. It covers about 26,250 ha and is situated between 32° 52'–33° 07' E and 0° 24'–0° 35' N, at an altitude of 1070–1340 m above sea level. The topography is characterized by gently undulating plains that have numerous flat topped hills and wide shadow valleys. Temperatures are fairly constant throughout the year, with an average of 26 °C. It has two peak rain seasons between March–May and September–November. Rainfall ranges between 1250 and 1400 mm per annum.

The forest is globally recognized as an important conservation biome rich in biodiversity, with over 300 bird species (Lepp et al. 2011) and 365 plant species (Howard and Davenport 1996). Currently, the forest has 27 enclaves; considering its proximity to Kampala city, the area has attractions for commercial utilization. Uganda's population growth rate of 3.2%, as per the 2002 population census (UBOS 2010), is one of the highest globally.

Mabira CFR was gazetted as a CFR in the 1900 under the Buganda agreement. It has been protected as a Forest Reserve since 1932 and is currently managed by the National Forest Authority (NFA). Forest management is under three main zones, namely: the strict nature reserve where no extraction is permitted except for research activities; the recreation buffer zone where activities like ecotourism and limited harvesting are permitted; and the production zone which accommodates agriculture,



**Fig. 1** A map showing the management zones of Mabira CFR and environs

livestock grazing, legal and unregulated harvesting of timber. The forest has undergone dramatic changes, especially since the early 1970s, in the form of encroachments and deforestation. These activities resulted from the desire by the government of the time to expand agriculture and permit free settlement anywhere. This forest region is estimated to have quite a high population density, with some places having an average of up to 15,122 people/sq. km in Parishes like Nakazadde (Schwarz and Fakultät für Geomatik, Hochschule Karlsruhe-Technik und Wirtschaft 2010) and an average of seven members per household. Over 80% of the population is heavily dependent on the forest ecosystem for their livelihood (Bush et al. 2004) in form of agriculture, lumbering, and brick laying. Studies by NFA (2009) indicate that population pressure coupled with high levels of poverty continue to constrain the remaining forest cover by way of conversion to other land uses. The high resistance over the proposal by government in 2007 to convert 7186 ha of forest to sugar production by the Sugar Corporation of Uganda Limited (SCOUL) is a case in point.

As a means to improve management in the forest reserve, several mechanisms have been devised in the revised forest management plan (MWE 2017), which include but not limited to: yield control and harvest, Collaborative Forest Management (CFM), licenses, silviculture, and rehabilitating encroachments. Despite the few success stories where CFM has been adopted, it is noteworthy that in the many communities where CFM agreements are implemented, no tangible economic benefits have been realized (Turyahabwe et al. 2012).

---

## **Estimating Biomass and Soil Organic Carbon Stocks in Mabira CFR**

### **Estimating Above-Ground Biomass and Carbon Stocks**

In order to determine the above-ground biomass (AGB) stocks, living biomass was considered. Studies by Djomo et al. (2010) and Brown (2002) have identified challenges of using the direct/destructive approach to estimate biomass. Consequently, we applied the indirect approach to estimate biomass content. The approach is not time consuming, cheap, and nondestructive, as borne out in studies by Tackenberg (2007), Chen et al. (2009), and Henry et al. (2011). The use of generalized allometric equations is proven and reliable in estimating AGB and carbon stocks and a number of them have been developed for different purposes, species, and regions.

More than 95% of the variation in AGB is explained by diameter at breast height (DBH) alone (Brown 2002). Studies by Djomo et al. (2010, 2016) and Ngomanda et al. (2014) show that the input of tree height improves the quality of AGB estimation. Biomass equations have been preferred, if a representative sample of tree-wise data is acquired (Brown 1997; Basuki et al. 2009; Djomo et al. 2010; Beets et al. 2012; Chave et al. 2014; Ngomanda et al. 2014; Mokria et al. 2015).

A team of eight people was employed in this process to survey management zones and take tree measurements. An NFA official with a security guard per management zone led the team in this exercise. Three management zones were



surveyed, each representing unique but homogeneous blocks. From the three zones, four compartments were considered as summarized in Table 1.

Resource utilization and management in the respective zones varies. Under the strict nature reserve, no extraction is permitted except for research activities, undertaken under very restrictive measures. Whereas the recreation buffer zone permits activities like ecotourism and limited harvesting, the production zone accommodates agriculture, livestock grazing, legal and unregulated harvesting of timber.

Field sites were randomly selected, taking 20 square plots of 30 m × 30 m from the strict nature reserve, where 63 trees were sampled. The same number of square plots of 50 m × 50 m was considered from the recreation/buffer and production zones, where measurements of 50 and 30 trees were taken, respectively. The plot sizes varied, considering variations in tree densities and sampling intensity. Consequently, bigger plot sizes were designated in areas where the trees were more scattered (recreation/buffer zone) to enable capturing of more trees for assessment. Tree measurements by height, diameter at breast height (DBH), canopy, and coordinates were taken and recorded. The tools used in determining AGB included GPS receivers, Suunto clinometers, a compass, caliper, and diameter tape (Fig. 2).

The measurements taken were then used to calculate biomass using allometry. For trees with multi-stems, the quadratic mean diameter (QMD) was calculated using Eq. (1) below:

$$\text{QMD} = \sqrt{(\pi * BA)/(4 * N)} \quad (1)$$

**Table 1** Sampled compartments

Management zone	Name and compartment number	Number of trees
Strict nature reserve	Compartment 209	63
	Compartment 212	
Recreation/buffer zone	Compartment 208	50
Production zone	Compartment 211	30
<b>Total number of trees samples</b>		<b>143</b>



**Fig. 2** Measurements for tree parameters

Where:

QMD is quadratic mean diameter.

BA is total basal area =  $ba_1 + ba_2 + ba_3 \dots$   $ba_N$  is the number of stems.

To estimate AGB, a number of models were explored and tested in relation to the variables. Models which included the diameter as predictor variable, a combination of diameter and tree height, diameter and crown diameter, and finally the diameter, tree height, and crown diameter were tested. These models are the most commonly used for allometry development (Brown et al. 1989; Chave et al. 2005; 2014; Djomo et al. 2010, 2016). The generalized allometric equation by Velle (1995) equations developed for Uganda to estimate AGB was applied as stated in Eq. (2).

$$\text{Ln (PWF)} = a + b * \text{Ln (D)} + c * \text{Ln (HT)} + d * \text{Ln (CR)} \quad (2)$$

Where:

PWF is fresh weight of a stem and branches in kg

D is DBH in cm

HT is height of the tree in m

CR is the width of the crown in meters.

a, b, c, and d are constants for all the pooled trees which may vary according to the diameter class as indicated in Table 2 below.

The application of the generalized allometric equation is avouched by its use even in highly diverse systems, where more than 95% of the variation in AGB is explained by DBH alone (Brown 2002). The fresh weight was then converted to dry weight for biomass detection by taking 50% of the wet weight (Gates et al. 1982). Below-ground biomass (BGB) was estimated by taking 20% of AGB (Mokany et al. 2006). From this, the total biomass per tree and per hectare was also calculated. Subsequently, carbon was converted into carbon sequestered (CO equivalents) by multiplying it with a factor of (44/12), which is the carbon dioxide-carbon molecular weight ratio (Penman et al. 2003). To assess the variation in biomass and carbon stocks for the different management zones, Anova for XLSTAST (version 3.1.3) was applied.

**Table 2** Constants for the varying diameter classes used to convert field vegetation measures

Diameter class	Constants			
	a	b	c	D
DBH <20 cm	-0.85989	1.5445	0.50663	0.333346
20 ≥ DBH ≤ 60 cm	-1.750891	1.943912	0.473731	0.245776
DBH ≥60 cm	-2.166502	2.032931	0.31292	0.436348

After Velle (1995)

The UBOS 2017 shapefile was used to estimate the total size of areas covered by the three management zones as indicated in Fig. 1. Data collected were analyzed using XLSTAST. The biomass was converted to carbon (C) by assuming a 50% biomass to carbon content (Brown 1997; Losi et al. 2003; Penman et al. 2003; Change 2006; FAO 2005).

## Estimating Soil Organic Carbon

According to Rau et al. (2011), the excavation of soil pits has been identified as a widely applicable and universally accepted method for the assessment of soil organic carbon (SOC). Samples of 50 m × 50 m plots up to 30 cm deep for the SOC pool were taken from the three management zones of the Mabira CFR and environs. Four dominant land use types, viz.: built-up area, plantations (sugarcane and/tea), subsistence farming, and forest were considered in each management zone. From each zone, 44 samples were taken, considering at least 3 points in each land use/cover type. A total of 132 soil samples were extracted from the 44 spots, taking three replicates from soil depth of 0–10 cm, 10–20 cm, and 20–30 cm. On completion of sample collection, the unwanted materials like stones, granules, plant parts, leaves, etc. were discarded. The soil samples were kept in polythene bags, tightly closed and well labeled. The bags were stored at 5 °C to limit microbial degradation, oxidation, and volatilization activities.

In the laboratory, samples were air dried and sieved through a 2-mm sieve. The sieved sample was used for SOC estimation. The samples were analyzed using wet oxidation method (Walkley and Black 1934), using potassium dichromate ( $K_2Cr_2O_7$ ) and concentrated sulfuric acid ( $H_2SO_4$ ). The samples were oven dried and a sample reagent mixture was prepared using standard laboratory procedures. The mixture was titrated with ferrous ammonium sulfate to determine the amount of organic carbon. Back titration was then performed until the color of the solution turned brown, which marked the end point. A standardization blank (without soil) was also run in the same way. Equation (3) was used to extract the carbon content.

$$BT - ST(0.3 \times 5)/0.3 \times 9.8 \quad (3)$$

Where:

BT = blank titer, which was considered at 9.8

ST = unused dichromate

All data were analyzed using SPSS statistical software version 16.0. Analysis of variance (ANOVA) was carried out using the two-factor randomized complete plot design. Significant F-values were obtained; differences between individual means were tested using the least significant difference (LSD) test. To assess variations in biomass and carbon stocks for the different management zones, Anova for XLSTAST (version 3.1.3) was applied.

## AGB and Carbon Stocks

Average AGB and AGC based on tree parameters comprising height, DBH, and crown diameter, as presented in Table 3 were 890.9 and 445.63 kg, respectively. Biomass and carbon totals of 1069.1 and 534.6 kg, respectively are also evident. A linear relationship between biomass and carbon stocks is presented in Fig. 3. The R-Squared statistic indicates that the model as fitted explains 100.0% of the variability in carbon stocks (tonnes per hectare). The correlation coefficient is 1.0, signifying a perfectly strong relationship between the two variables. Since the P-value is greater than 0.05, there is no indication of serial autocorrelation in the residuals at the 95.0% confidence level. BGB was estimated by applying the 20% conversion rate to AGB (Mokany et al. 2006). Similarly, 50% of the BGB is taken as the estimation for BGC, results of which are presented in Table 3.

Variations of biomass and carbon stocks were noted in the different management zones. The highest average total AGB was found in the strict nature reserve, where values of the multiparameters of DBH, height and crown diameter were highest as well. The production zone, which had scattered trees with smaller parameters registered the lowest average total AGB (Table 4). Whereas the strict nature reserve had the highest carbon stocks, the production zone registered the least (Tables 5 and 6).

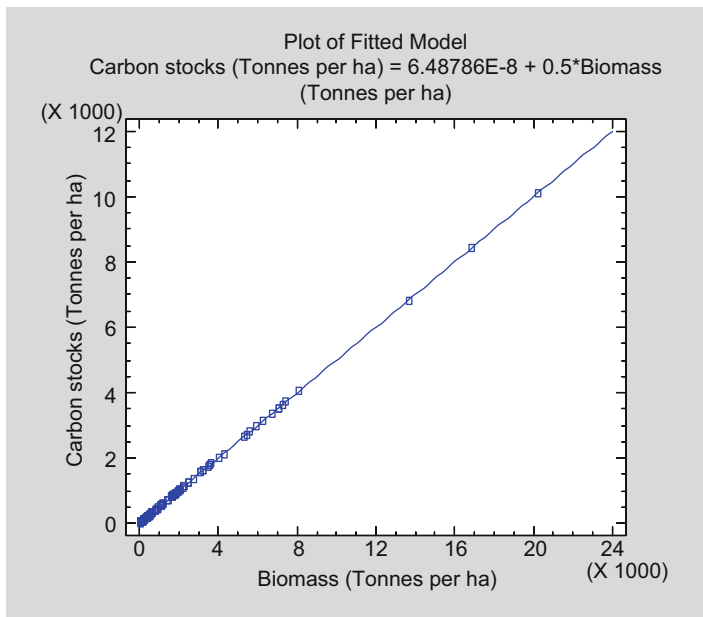
The ANOVA (Table 7) decomposes the variance of carbon stocks (kg per tree) into two components: a between-group and within-group components. The F-ratio, which in this case is 13.97, is a ratio of the between-group estimate to the within-group estimate. Since the P-value of the F-test is less than 0.05, there is a statistically significant difference between the mean carbon stocks (tonnes per hectare) from one management zone to another at the 5% significance level. To determine which means are significantly different from others, multiple range tests were selected from the list of tabular options.

The multiple comparison procedure is applied (Table 8) to determine which means are significantly different from others. The bottom half of the output shows the estimated difference between each pair of means. An asterisk to signify statistically significant differences at the 95.0% confidence level has been placed next to the pairs. In the table, two homogenous groups are identified using columns of Xs. Within each column, the levels containing Xs form a group of means within which there are no statistically significant differences. According to Fisher's least significant difference (LSD) procedure used to discriminate among the means, there is a 5% risk of calling each pair of means significantly different when the actual difference is 0 (Fig. 4).

A comparison of tree carbon stocks and sequestration per management zone was also done, and it was revealed that the highest carbon is in the strict nature reserve and least in the production zone as shown in Table 9.

It is noticeable from Tables 9 and 10 that carbon sinking varies between the management zones. Table 10 shows that the strict nature reserve management zone sinks the highest volume of carbon of approximately 6,771,092.34 tonnes, despite its small coverage in comparison to the recreation/buffer (2,196,467.59 tonnes) and production zones (458,903.57 tonnes).





**Fig. 3** Relationship between biomass and carbon

**Table 4** Summary statistics for average tree biomass stocks (kg)

Management zones	Count	Average biomass (kg)	Standard deviation	Coeff. of variation (%)	Minimum	Maximum
Production zone	30	181.436	319.433	176.059	24.124	1783.39
Recreation/ buffer zone	50	506.0548	627.4903	123.9965	36.3592	3117.55
Strict nature reserve	63	1534.23	1895.35	123.537	37.1147	10,121.2
Total	143	887.516	1439.42	162.186	24.124	10,121.2

It is also important to compare SOC in forest environments. Comparison for variations of soil organic carbon in Mabira forest was done basing on the SOC percentage content. It was noted that there was no variation in the mean SOC for the three management zones. In terms of soil depth, the 0–10 cm and 10–20 cm soil layers had relatively similar variations of least square means for carbon than the 20–30 cm soil layer. The highest SOC was observed in the soil surface of 0–10 cm depth, with the highest mean of 2.78% across all the management zones. As expected, soil organic matter decreases with depth and varies with land use/cover type. Whereas the forest and subsistence farming land use/cover types had relatively higher means of SOC (with legumes and bananas as dominant crops), low mean variations for

**Table 5** Descriptive statistics for carbon stocks (kg per tree) by management zones

Description								
Carbon								
	N	Mean	Std. deviation	Std. error	95% Confidence interval for mean		Min.	Max.
					Lower bound	Upper bound		
Strict nature reserve	63	920.54	1137.21	143.275	634.14	1206.94	22	6073
Recreation buffer	50	303.63	376.49	53.244	196.63	410.63	22	1871
Production zone	30	108.86	191.66	34.992	37.29	180.43	14	1070
Total	143	534.56	862.69	72.142	391.95	677.17	14	6073

**Table 6** Variance of carbon stocks (kg per tree) by management zone

Source of variations	Sum of squares	d.f.	Mean square	F-ratio	Sig.
Between groups	1.749E7	2	8,744,327.239	13.881	0.000
Within groups	8.819E7	140	629,941.672		
Total (corr.)	1.057E8	142			

**Table 7** Analysis of variance for carbon stocks (kg per tree) – type III sums of squares

Source	Sum of squares	d.f.	Mean square	F-ratio	<i>P</i> -value
Main effects					
Management zones	4.89	2	2.44	13.97	0.0000
Residual	2.45	140	1.75		
Total (corrected)	2.94	142			

All F-ratios are based on the residual mean square error

carbon were recorded in both the tea and sugarcane plantations, and built-up areas (Table 11 and Fig. 5).

Among the three factors (soil depth, management zones, land use/cover types) assessed for SOC variations, it was soil depth and land use/cover types that had a statistically significant effect on the percentage of carbon ( $P = 0.05$ ), as presented in Table 12.

## Discussion

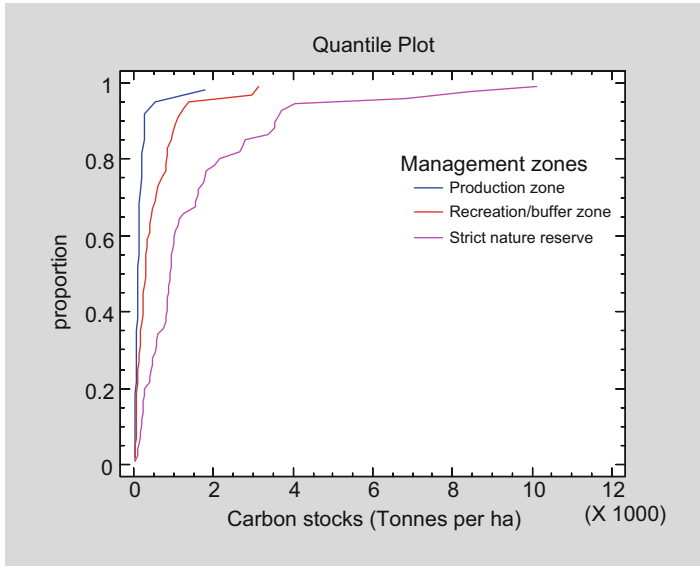
Velle (1995) allometric equation was adopted and here combinations of tree parameters are applied. Similar recommendations for specific diameter–height allometries are made in studies by Feldpausch et al. (2011) and Banin et al. (2012). According to Sharifi et al. (2016), blending parameters may give better results. Although DBH was found to be a significant parameter in determining AGB and C (Dudley and

**Table 8** Multiple range tests for carbon stocks (tonnes per hectare) by management zones – method: 95.0% LSD

Level	Count	Mean	Homogeneous groups			
Production zone	30	181.43	X			
Recreation/buffer zone	50	496.30	X			
Strict nature reserve	63	1534.23	X			
<b>Multiple comparisons</b>						
Carbon LSD						
(I) Zone	(J) Zone	Mean difference (I-J)	Std. error	Sig.	95% confidence interval	
SNR	Recreation buffer	616.90 <sup>a</sup>	150.326	0.000	Lower bound	Upper bound
	Production zone	811.67 <sup>a</sup>	176.06	0.000	319.70	914.11
Recreation buffer	SNR	-616.90 <sup>a</sup>	150.33	0.000	463.60	1159.76
	Production zone	194.77	183.30	0.290	-914.11	-319.70
Production zone	SNR	-811.68 <sup>a</sup>	176.06	0.000	-167.61	557.15
	Recreation buffer	-194.77	183.30	0.290	-1159.76	-463.60
					-557.15	167.61

<sup>a</sup>The mean difference is significant at the 0.05 level





**Fig. 4** Carbon stocks in the different management zones, indicating highest carbon concentrations in the strict nature reserve

**Table 9** Average biomass, carbon, and carbon sequestered per tree in the management zones of Mabira CFR

Management zone	Biomass/kg	Carbon stock/kg	Carbon sequestered
Strict nature reserve	1841 ± 321.7	920.5 ± 160.8	3375 ± 589.7
Recreation/buffer	607.2 ± 106.5	303.6 ± 53	1113 ± 195
Production	217.7 ± 54.2	108.9 ± 27.1	399.2 ± 99.4

Fownes 1992), it was also noted that higher estimations of AGB and carbon were indicated where DBH and H were combined. It was also noted that a coefficient of 1.0 indicated a perfectly strong relationship between AGB and carbon. Such a significant logarithmic relationship was also identified by Clark et al. (2001) and Krisnawati et al. (2012).

The results reveal a positive relationship between land use/cover and carbon sequestration, since the strict nature reserve has more AGB stocks. Therefore, conservation of forests with large carbon stocks would reduce carbon dioxide emissions than the production zone, where pockets of degradation are evident, despite isolated afforestation and reforestation attempts. The findings are in keeping with Sharma et al. (2010), implying that preserving old growth strands maintains large amounts of carbon stocks and also promotes sequestration of much more carbon than exotic forests.

The strict nature reserve covering 3857 ha sinks approximately 6,771,092.34 tonnes. However, government plans to reduce this area to 3189 ha and increase the production

**Table 10** Total tree carbon estimates per management zone

Management zone	Estimated coverage (ha)	Average tree counts per hectare	Average tree carbon (kg)	Total carbon per hectare (kg)	Average carbon per management zone	Average carbon per hectare (tonnes)	Average carbon sequestered (tonnes) per zone
Strict nature reserve	3857.82	520	920.5	478,680	1,846,661,548	1,846,661.55	6,771,092.34
Recreation/ buffer	5233.15	337	303.6	114,469.6	599,036,614.3	599,036.61	2,196,467.58
Production	17,159.38	67	108.8	7293.7	125,155,501.8	125,155.50	458,903.57

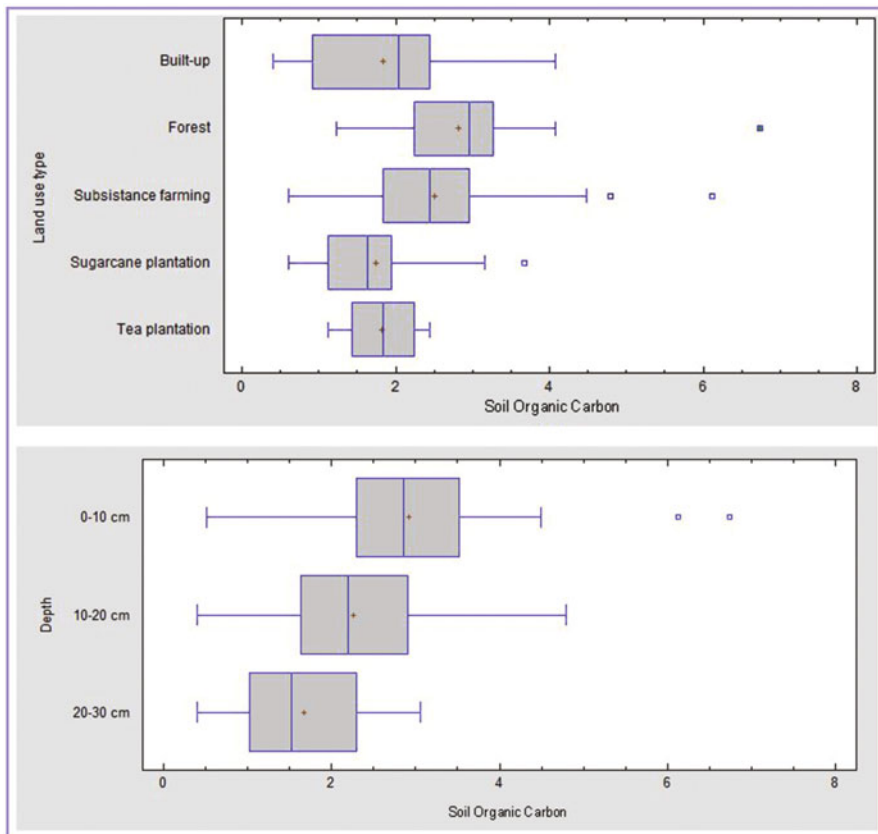
**Table 11** Least squares means for SOC with 95.0% confidence intervals

Level	Count	Mean (%)	Std. error	Lower limit	Upper limit
Grand mean	132	2.17994			
<b>Soil depth</b>					
0–10 cm	44	2.78	0.16	2.47	3.09
10–20 cm	44	2.17	0.15	1.87	2.47
20–30 cm	44	1.59	0.15	1.28	1.89
<b>Management zones</b>					
Production zone	24	2.25	0.21	1.82	2.67
Recreation/buffer zone	60	2.11	0.12	1.88	2.35
Strict nature reserve	48	2.18	0.14	1.88	2.47
<b>Land use/cover types</b>					
Built-up	24	1.88	0.19	1.49	2.26
Forest	36	2.81	0.15	2.52	3.10
Subsistence farming	40	2.45	0.14	2.17	2.73
Sugarcane plantation	26	1.86	0.19	1.50	2.25
Tea plantation	6	1.89	0.38	1.14	2.63

zone to 26,785 ha (NFA 2017). This would reduce the carbon sink and pave the way for further global warming, related to unsustainable agricultural practices, which include deforestation, bush burning, overgrazing, monoculture, and overcultivation, all of which degrade the environment.

Soils are the main terrestrial carbon sink; the conservation of soil carbon reduces carbon emissions, as well as the risks of climate change. Land use and cover change are noted to significantly influence carbon variations. Under the strict nature reserve, where the dominant land cover type is forest, most of the activities are conservation, hence more carbon stocks, as opposed to the plantation area, which is more commercial with lower carbon stocks. This is in keeping with studies by Desjardins et al. (2004) and Meyer et al. (2012). Furthermore, SOC was found highest in the top layer of soil (0–10 cm). This is explained by the rapid decomposition of forest litter, which provides abundant organic matter. This is corroborated by studies by Mendoza-Vega et al. (2003) and Chowdhury et al. (2007), where more SOC was identified as located at the soil depth of 0–14 cm. Furthermore, the highest and lowest AGC concentration was identified in the strictly managed and production zones, respectively. This is in conformity with findings by Brakas and Aune (2011), who noted that AGC stocks were very low in degraded, as opposed to preserved forests.

Land management practices can significantly affect the content and distribution of SOC in different vegetation types (Li et al. 2014; Zhang et al. 2014; Baritz et al. 2010). The highest SOC concentrations were noted in the production zone and lowest in the recreation/buffer zone. By implication, if well managed through conservation attempts such as afforestation, reforestation, longer fallows and mulching, agricultural soils have a great potential for carbon sinking. Studies by McKinley et al. (2011) and Ryan et al. (2010) indicate that reducing the amount of



**Fig. 5** Percentage SOC variations per land use/cover type, management zone, and soil depth

**Table 12** Analysis of variance for SOC – type III sums of squares

Source	Sum of squares	d.f.	Mean square	F-ratio	P-value
<b>Main effects</b>					
Soil depth	31.0391	2	15.5195	19.89	0.0000 <sup>a</sup>
Management zone	0.282212	2	0.141106	0.18	0.8348
Land use type	17.1589	4	4.28971	5.50	0.0004 <sup>a</sup>
Residual	95.985	123	0.780366		
Total (corrected)	152.692	131			

All F-ratios are based on the residual mean square error

<sup>a</sup>Significant at 0.05% level of significance

forest harvest can decrease carbon losses to the atmosphere. As stated by Schwilk et al. (2009) and Stephens et al. (2012), forest disturbances can lead to additional soil carbon losses through soil erosion inducement.

## Conclusion

The main aim of this chapter was to assess the effect of forest management options on biomass and SOC variations in Mabira CFR. AGB and carbon stocks (t/ha) of forest (trees) and SOC were estimated using allometric equations and sampling techniques. A multiparameter assessment of DBH, H, and crown diameter, and soil samples of 0–30 depth provided replicable results for tree stand AGB and SOC.

The highest AGB was evident in areas where forest was still intact (strict nature reserve), as opposed to the degraded and encroached areas (production zone). SOC varied with soil depth and land use/cover types. Another important revelation in this chapter is that SOC concentration is greatest in the production zone. By implication, if well managed through conservation measures such as afforestation, reforestation, longer fallow periods, and mulching, SOC in legume enhanced agricultural soils have a great potential as carbon sinks. The lowest SOC was noted in the recreation/buffer zone (0.4%). Land use type, AGB, and forest management in the different zones are identified as the key drivers of carbon stock variations in Mabira CFR. Priority should be given to reducing deforestation and restore degraded areas. This can be achieved through demarcating forest boundaries to minimize encroachment, enforcement of policy on forestry for sustainable development, and promotion of reforestation programs.

---

## References

- Arsanjani JJ (2012) Analysis of results. In: Dynamic land use/cover change modelling. Springer, Berlin/Heidelberg, pp 109–130
- Baccini AGSJ, Goetz SJ, Walker WS, Laporte NT, Sun M, Sulla-Menashe D, Hackler J, Berk PSA, Dubayah R, Friedl MA, Samanta S (2012) Estimated carbon dioxide emissions from tropical deforestation improved by carbon-density maps. *Nat Clim Chang* 2(3):182
- Banin L, Feldpausch TR, Phillips OL (2012) Cross-continental comparisons of maximum tree height and allometry: testing environmental, structural and floristic drivers. *Glob Ecol Biogeogr* 21:1179–1190
- Baritz R, Seufert G, Montanarella L, Van Ranst E (2010) Carbon concentrations and stocks in forest soils of Europe. *For Ecol Manag* 260(3):262–277
- Basuki TM, Van Laake PE, Skidmore AK, Hussin YA (2009) Allometric equations for estimating the above-ground biomass in tropical lowland Dipterocarp forests. *For Ecol Manag* 257(8):1684–1694
- Beets PN, Kimberley MO, Oliver GR, Pearce SH, Graham JD, Brandon A (2012) Allometric equations for estimating carbon stocks in natural forest in New Zealand. *Forests* 3(3):818–839
- Brakas SG, Aune JB (2011) Biomass and carbon accumulation in land use systems of Claveria, the Philippines. In: Carbon sequestration potential of agroforestry systems. Springer, Dordrecht, pp 163–175
- Brown S (1997) Estimating biomass and biomass change of tropical forests: a primer. FAO forestry paper 134. Food and Agriculture Organization of the United Nations, Rome
- Brown S (2002) Measuring carbon in forests: current status and future challenges. *Environ Pollut* 116(3):363–372
- Brown S, Lugo AE (1984) Biomass of tropical forests: a new estimate based on forest volumes. *Science* 223(4642):1290–1293
- Brown S, Gillespie AJ, Lugo AE (1989) Biomass estimation methods for tropical forests with applications to forest inventory data. *For Sci* 35(4):881–902

- Bush G, Nampindo S, Aguti C, Plumptre A (2004) The value of Uganda's forests: a livelihoods and ecosystems approach. Wildlife Conservation Society, Kampala
- Change IPOC (2006) IPCC guidelines for national greenhouse gas inventories. Institute for Global Environmental Strategies, Hayama, Kanagawa, Japan.
- Chave J, Andalo C, Brown S, Cairns MA, Chambers JQ, Eamus D, Fölster H, Fromard F, Higuchi N, Kira T, Lescure JP (2005) Tree allometry and improved estimation of carbon stocks and balance in tropical forests. *Oecologia* 145(1):87–99
- Chave J, Réjou-Méchain M, Búrquez A, Chidumayo E, Colgan MS, Delitti WB, Duque A, Eid T, Fearnside PM, Goodman RC, Henry M (2014) Improved allometric models to estimate the aboveground biomass of tropical trees. *Glob Chang Biol* 20(10):3177–3190
- Chen W, Li J, Zhang Y, Zhou F, Koehler K, LeBlanc S, Fraser R, Olthof I, Zhang Y, Wang J (2009) Relating biomass and leaf area index to non-destructive measurements in order to monitor changes in Arctic vegetation. *Arctic* 62:281–294
- Chowdhury MSH, Biswas S, Halim MA, Haque SS, Muhammed N, Koike M (2007) Comparative analysis of some selected macronutrients of soil in orange orchard and degraded forests in Chittagong Hill Tracts, Bangladesh. *J For Res* 18(1):27–30
- Clark DA, Brown S, Kicklighter DW, Chambers JQ, Thomlinson JR, Ni J, Holland EA (2001) Net primary production in tropical forests: an evaluation and synthesis of existing field data. *Ecol Appl* 11(2):371–384
- Desjardins T, Barros E, Sarrazin M, Girardin C, Mariotti A (2004) Effects of forest conversion to pasture on soil carbon content and dynamics in Brazilian Amazonia. *Agric Ecosyst Environ* 103(2):365–373
- Dixon RK, Solomon AM, Brown S, Houghton RA, Trexler MC, Wisniewski J (1994) Carbon pools and flux of global forest ecosystems. *Science* 263(5144):185–190
- Djomo AN, Ibrahima A, Saborowski J, Gravenhorst G (2010) Allometric equations for biomass estimations in Cameroon and pan moist tropical equations including biomass data from Africa. *For Ecol Manag* 260(10):1873–1885
- Djomo AN, Picard N, Fayolle A, Henry M, Ngomanda A, Ploton P, McLellan J, Saborowski J, Adamou I, Lejeune P (2016) Tree allometry for estimation of carbon stocks in African tropical forests. *Forestry* 89(4):446–455
- Dudley NS, Fownes JH (1992) Preliminary biomass equations for eight species of fast-growing tropical trees. *J Trop For Sci* 5:68–73
- Ellis E, Pontius R (2007) Land-use and land-cover change. *Encyclopedia of earth* 1–4
- FAO (2010) Global forest resources assessment 2000. FAO forestry paper, 140. FAO, Rome. Agriculture Organization of the United Nations. (2001)
- FAO (2011) La situation des forêts dans le bassin amazonien, le bassin du Congo et l'Asie du Sud-Est. FAO, ITTO, Sommet des trois Bassins Forestiers Tropicaux, Brazzaville
- FAO (2016) State of the World's Forests 2016. Forests and agriculture: land-use challenges and opportunities. FAO, Rome
- Feldpausch TR, Banin L, Phillips OL, Baker TR, Lewis SL, Quesada CA, Affum-Baffoe K, Arets EJ, Berry NJ, Bird M, Brondizio ES (2011) Height-diameter allometry of tropical forest trees. *Biogeosciences* 8:1081–1106
- Foley JA, DeFries R, Asner GP, Barford C, Bonan G, Carpenter SR, Chapin FS, Coe MT, Daily GC, Gibbs HK, Helkowski JH (2005) Global consequences of land use. *Science* 309(5734):570–574
- Gates MA, Rogerson A, Berger J (1982) Dry to wet weight biomass conversion constant for *Tetrahymena elliotti* (Ciliophora, Protozoa). *Oecologia* 55(2):145–148
- Hairiah K, Dewi S, Agus F, Velarde S, Ekadinata A, Rahayu S, van Noordwijk M (2011) Measuring carbon stocks across land use systems. World Agroforestry Centre, Bogor
- Harris NL, Brown S, Hagen SC, Saatchi SS, Petrova S, Salas W, Hansen MC, Potapov PV, Lotsch A (2012) Baseline map of carbon emissions from deforestation in tropical regions. *Science* 336(6088):1573–1576
- Hashim JH, Hashim Z (2016) Climate change, extreme weather events, and human health implications in the Asia Pacific region. *Asia Pac J Public Health* 28(2 Suppl):8S–14S
- Henry M, Picard N, Trotta C, Manlay R, Valentini R, Bernoux M, Saint André L (2011) Estimating tree biomass of sub-Saharan African forests: a review of available allometric equations. *Silva Fennica* 45(3B):477–569

- Howard PC, Davenport TRB (1996) Forest biodiversity reports. Uganda Forest Department, Kampala
- Jandl R, Lindner M, Vesterdal L, Bauwens B, Baritz R, Hagedorn F, Johnson DW, Minkinen K, Byrne KA (2007) How strongly can forest management influence soil carbon sequestration? *Geoderma* 137(3–4):253–268
- Jjagwe A, Kakembo V, Barasa B (2017) An assessment of the spatial and temporal changes of Mabira tropical forest reserve and its environs, Central Uganda. *Tanzania J Dev Stud* 15(1–2):32–52
- Kerr JT, Kharouba HM, Currie DJ (2007) The macroecological contribution to global change solutions. *Science* 316(5831):1581–1584
- Krisnawati H, Adinugroho WC, Imanuddin R (2012) Monograph allometric models for estimating tree biomass at various forest ecosystem types in Indonesia. Research and Development Center for Conservation and Rehabilitation, Forestry Research and Development Agency, Ministry of Forestry, Bogor
- Lambin EF, Geist HJ (eds) (2008) Land-use and land-cover change: local processes and global impacts. Springer Science & Business Media, Dordrecht
- Lepp A, Gibson H, Lane C (2011) Image and perceived risk: a study of Uganda and its official tourism website. *Tour Manag* 32(3):675–684
- Li Y, Zhang J, Chang SX, Jiang P, Zhou G, Shen Z, Wu J, Lin L, Wang Z, Shen M (2014) Converting native shrub forests to Chinese chestnut plantations and subsequent intensive management affected soil C and N pools. *For Ecol Manag* 312:161–169
- Losi CJ, Siccama TG, Condit R, Morales JE (2003) Analysis of alternative methods for estimating carbon stock in young tropical plantations. *For Ecol Manag* 184(1–3):355–368
- McKinley DC, Ryan MG, Birdsey RA, Giardina CP, Harmon ME, Heath LS, Houghton RA, Jackson RB, Morrison JF, Murray BC, Pataki DE (2011) A synthesis of current knowledge on forests and carbon storage in the United States. *Ecol Appl* 21(6):1902–1924
- Mendoza-Vega J, Karlton E, Olsson M (2003) Estimations of amounts of soil organic carbon and fine root carbon in land use and land cover classes, and soil types of Chiapas highlands, Mexico. *For Ecol Manag* 177(1–3):191–206
- Meyer S, Leifeld J, Bahn M, Fuhrer J (2012) Free and protected soil organic carbon dynamics respond differently to abandonment of mountain grassland. *Biogeosciences* 9(2):853–865
- Mokany K, Raison RJ, Prokushkin AS (2006) Critical analysis of root: shoot ratios in terrestrial biomes. *Glob Chang Biol* 12(1):84–96
- Mokria M, Gebrekirstos A, Aynekulu E, Bräuning A (2015) Tree dieback affects climate change mitigation potential of a dry afro-montane forest in northern Ethiopia. *For Ecol Manag* 344:73–83
- MWE (2017) Mabira central forest reserves. 26 Jun 2020, Retrieved from: <https://www.mwe.go.ug/library/forestry-documents>
- National Forestry Authority (2009) National Biomass Study Technical Report
- Ngomanda A, Obiang NLE, Lebamba J, Mavouroulou QM, Gomat H, Mankou GS, Loumeto J, Iponga DM, Ditsouga FK, Koumba RZ, Bobé KHB (2014) Site-specific versus pantropical allometric equations: which option to estimate the biomass of a moist central African forest? *For Ecol Manag* 312:1–9
- Ochoa-Gaona S, Gonzalez-Espinosa M (2000) Land use and deforestation in the highlands of Chiapas, Mexico. *Appl Geogr* 20:17–42
- Olson JS, Watts JA, Allison LJ (1983) Carbon in live vegetation of major world ecosystems (no. 1997). Oak Ridge National Laboratory, Oak Ridge
- Parresol BR (1999) Assessing tree and stand biomass: a review with examples and critical comparisons. *For Sci* 45(4):573–593
- Parry M, Parry ML, Canziani O, Palutikof J, Van der Linden P, Hanson C (eds) (2007) Climate change 2007 – impacts, adaptation and vulnerability: working group II contribution to the Fourth Assessment Report of the IPCC, vol 4. Cambridge University Press, Cambridge, UK
- Penman J, Gytarsky M, Hiraishi T, Krug T, Kruger D, Pipatti R, Buendia L, Miwa K, Ngara T, Tanabe K, Wagner F (2003) Good practice guidance for land use, land-use change and forestry. Good practice guidance for land use, land-use change and forestry

- Rau BM, Melvin AM, Johnson DW, Goodale CL, Blank RR, Fredriksen G, Miller WW, Murphy JD, Todd Jr, DE, Walker RF (2011) Revisiting soil carbon and nitrogen sampling: Quantitative pits versus rotary cores. *Soil science* 176(6):273–279
- Ryan MG, Harmon ME, Birdsey RA, Giardina CP, Heath LS, Houghton RA, Jackson RB, McKinley DC, Morrison JF, Murray BC, Pataki DE (2010) A synthesis of the science on forests and carbon for US forests. *Ecol Soc Am: Issues Ecol* 13:1–16
- Schimmel DS, House JI, Hibbard KA, Bousquet P, Ciais P, Peylin P, Braswell BH, Apps MJ, Baker D, Bondeau A, Canadell J (2001) Recent patterns and mechanisms of carbon exchange by terrestrial ecosystems. *Nature* 414(6860):169
- Schwarz S, Fakultät für Geomatik, Hochschule Karlsruhe-Technik und Wirtschaft (2010) The BIOTA East Africa atlas: rainforest change over time. Faculty of Geomatics, Karlsruhe University of Applied Sciences, Karlsruhe
- Schwilk DW, Keeley JE, Knapp EE, McIver J, Bailey JD, Fettig CJ, Fiedler CE, Harrod RJ, Moghaddas JJ, Outcalt KW, Skinner CN (2009) The National Fire and Fire Surrogate Study: effects of fuel reduction methods on forest vegetation structure and fuels. *Ecol Appl* 19(2):285–304
- Sharifi A, Amini J, Tateishi R (2016) Estimation of forest biomass using multivariate relevance vector regression. *Photogramm Eng Remote Sens* 82(1):41–49
- Sharma CM, Baduni NP, Gairola S, Ghildiyal SK, Suyal S (2010) Tree diversity and carbon stocks of some major forest types of Garhwal Himalaya, India. *For Ecol Manag* 260(12):2170–2179
- Shrestha DP, Zinck JA, Van Ransst E (2004) Modelling land degradation in the Nepalese Himalaya. *Catena* 57(2):135–156
- Stephens SL, McIver JD, Boerner RE, Fettig CJ, Fontaine JB, Hartsough BR, Kennedy PL, Schwilk DW (2012) The effects of forest fuel-reduction treatments in the United States. *Bioscience* 62(6):549–545
- Tackenberg O (2007) A new method for non-destructive measurement of biomass, growth rates, vertical biomass distribution and dry matter content based on digital image analysis. *Ann Bot* 99(4):777–783
- Thornes JE (2002) In: McCarthy JJ, OF Canziani, Leary NA, Dokken DJ, White KS (eds) IPCC 2001. Climate change 2001: impacts, adaptation and vulnerability, contribution of working group II to the Third Assessment Report of the Intergovernmental Panel on Climate Change. Cambridge University Press, Cambridge, UK/New York, p 1032. ISBN 0-521-01500-6 (paperback), ISBN 0-521-80768-9 (hardback). *Int J Climatol: J R Meteorol Soc* 22(10):1285–1286
- Turyahabwe N, Agea JG, Tweheyo M, Tumwebaze SB (2012) Collaborative forest management in Uganda: benefits, implementation challenges and future directions. *Sustainable Forest Management: Case Studies* 51.
- UBOS, U. (2010) 2010 Statistical abstract
- UNEP (2002) Global environmental outlook: 3. Past, present and future perspectives. Earthscan Publications, London
- Velle K (1995) Estimation of standing stock of woody biomass in areas where little or no baseline data are available. A study based on field measurements in Uganda. Norges Landbrukshøgskole, Ås
- Walkley A, Black IA (1934) An examination of the Degtjareff method for determining soil organic matter, and a proposed modification of the chromic acid titration method. *Soil Sci* 37(1):29–38
- Watson RT, Noble IR, Bolin B, Ravindranath NH, Verardo DJ, Dokken DJ (2000) Land use, land-use change and forestry: a special report of the Intergovernmental Panel on Climate Change. Cambridge University Press, Cambridge, UK
- Zhang J, Li Y, Chang SX, Jiang P, Zhou G, Liu J, Wu J, Shen Z (2014) Understorey vegetation management affected greenhouse gas emissions and labile organic carbon pools in an intensively managed Chinese chestnut plantation. *Plant Soil* 376(1–2):363–375
- Zheng D, Rademacher J, Chen J, Crow T, Bresee M, Le Moine J, Ryu SR (2004) Estimating aboveground biomass using Landsat 7 ETM+ data across a managed landscape in northern Wisconsin, USA. *Remote Sens Environ* 93(3):402–411



**Open Access** This chapter is licensed under the terms of the Creative Commons Attribution 4.0 International License (<http://creativecommons.org/licenses/by/4.0/>), which permits use, sharing, adaptation, distribution and reproduction in any medium or format, as long as you give appropriate credit to the original author(s) and the source, provide a link to the Creative Commons license and indicate if changes were made.

The images or other third party material in this chapter are included in the chapter's Creative Commons license, unless indicated otherwise in a credit line to the material. If material is not included in the chapter's Creative Commons license and your intended use is not permitted by statutory regulation or exceeds the permitted use, you will need to obtain permission directly from the copyright holder.





# Women Participation in Farmer Managed Natural Regeneration for Climate Resilience: Laisamis, Marsabit County, Kenya

# 134

Irene Ojuok and Tharcisse Ndayizigiye

## Contents

Introduction .....	2757
Findings and Recommendations .....	2761
To Identify Potential Risks Associated with Climate Change and Land Degradation Facing the Communities in Laisamis (Mention the Key Threats, Who Is Most at Risk, Why) .....	2761
Assess the Opportunities FMNR Has in Increasing the Resilience of the Communities to these Risks (Define FMNR, Its Key Benefits from an Environmental, Economic, Social View, etc.) .....	2763
What Are the Roles of Men and Women in Uptake of FMNR .....	2764
What Drives Women to Participate in or to Adopt FMNR .....	2765
Key Barriers Affecting Women Participation in FMNR .....	2766
Recommendations for Enhancing Women Participation in FMNR Uptake .....	2768
Limitation of the Study .....	2769
Conclusion .....	2770
References .....	2773

This chapter was previously published non-open access with exclusive rights reserved by the Publisher. It has been changed retrospectively to open access under a CC BY 4.0 license and the copyright holder is “The Author(s)”. For further details, please see the license information at the end of the chapter.

I. Ojuok (✉)

National Technical specialist Environment and Climate Change, World Vision Kenya, Nairobi, Kenya

e-mail: [Irene\\_ojuok@wvi.org](mailto:Irene_ojuok@wvi.org); [barrackawino@yahoo.com](mailto:barrackawino@yahoo.com)

T. Ndayizigiye

SMHI/Swedish Meteorological and Hydrological Institute, Nairobi, Kenya

e-mail: [Tharcisse.Ndayizigiye@smhi.se](mailto:Tharcisse.Ndayizigiye@smhi.se)

© The Author(s) 2021

W. Leal Filho et al. (eds.), *African Handbook of Climate Change Adaptation*,  
[https://doi.org/10.1007/978-3-030-45106-6\\_152](https://doi.org/10.1007/978-3-030-45106-6_152)

2755

---

**Abstract**

Despite the fact that land degradation is both natural and human-induced, it is proven that human activities pose greatest threat and these include unsustainable land management practices such as destruction of natural vegetation, over-cultivation, overgrazing, poor land husbandry, and excessive forest conversion. Other than reduced productivity, land degradation also leads to socioeconomic problems such as food insecurity, insufficient water, and regular loss of livestock which exacerbate poverty, conflicts, and gender inequalities that negatively impact mostly women and children especially the rural population. Increased efforts by governments, donors, and partners toward reversing land degradation through community-led, innovative, and effective approaches therefore remain to be crucial today than never before!

Farmer-managed natural regeneration (FMNR) is a proven sustainable land management technology to restore degraded wasteland and improve depleted farmland. This approach has been tested across Africa with high success rates. In spite of the huge local, regional, and global efforts plus investments put on promoting FMNR across different landscapes among vulnerable communities for climate resilience, the implementation of such projects has not been as successful as intended due to slow women uptake and participation in the approach. In order of ensuring women who are mostly at highest risk to impacts of climate change enjoy the multiple benefits that come along with FMNR, the success rate for uptake of FMNR especially among women need to be enhanced.

This chapter seeks to explore drivers and barriers of women participation in uptake of FMNR for climate resilience. Findings will be shared from a 3-year project dubbed Integrated Management of Natural Resources for Resilience in ASALs and a Food and Nutrition project both in Laisamis, Marsabit County, Kenya. The program interventions on natural resource management for livelihoods seek to integrate gender and conflict prevention and prioritize sustainable, market-based solutions to address the persistent challenges. The chapter discusses findings, successes, and lessons learned from the actions and the requirement to position women as vulnerable groups at the center of initiatives designed to address the climate change crisis. The outcome of this chapter will enhance gender-responsive FMNR programing through awareness creation, effective organization/project designs, strategies, and plans together with advocacy and policy influence. Limitations of the study and main recommendations for future programing in similar contexts are also shared.

---

**Keywords**

Gender · Mainstreaming · Women · Participation · FMNR Uptake · Climate resilience · Marsabit · Kenya

## Introduction

Climate change is so far viewed as one of the greatest challenges facing humanity manifested in the form of variation in amount and distribution of precipitation, ocean salinity, wind patterns, and aspects of extreme weather leading to droughts and flooding, among others. These changes threaten community livelihoods, economy, ecosystems, and social cohesion. Africa is particularly viewed to bear the brunt of the climate change threats mainly due to its poor economic development and low institutional capacity. Vulnerable communities especially women and children within the continent are facing the highest pressure following conspicuous threats like decline in crop production, livestock deaths due to droughts, malnutrition, resource-based conflicts, and migration (Fig. 1).

Globally, women are underrepresented in natural resource management (NRM) and peace building, and they are also disproportionately affected by poor NRM because of gendered power relations that deny women access to resources such as land. Women especially in the rural areas are primary providers of water, food, and energy at the household level and therefore bear heaviest impact of poor resource management. In many of the ASALS areas of Kenya, the frequency and magnitude of droughts, floods, and famine have increased significantly in the recent past. This has impacted nega-



**Fig. 1** Women in search of firewood, Marsabit, Kenya, February 2019. (Photo: Irene Ojuok, World Vision Kenya)

tively on the pastoralist communities and especially the women whose vulnerability to the impacts of climate change is necessitated by their roles at household level as caregivers. In Kenya, tens of thousands of hectares of farmlands have become so degraded that they no longer produce adequate or regular crops or pasture for livestock. Historically, there has been a male bias in development program research, planning, and implementation activities, which ignore women's role in dryland development and the challenges that they face. Moreover, women generally do not participate in the decision-making processes in the community. Increasingly, women and youth are usually the most marginalized groups often suffering first in situations of severe food and water shortage. They carry the largest burden of searching for fuelwood, pasture, cooking food, and gathering wild fruits, among others. Poor management of natural resources can lead to overuse and degradation, desertification, deforestation, soil erosion, declining water tables, and other effects that can threaten livelihoods and peace. Sometimes, this leads to conflict at household or even between communities. Forest goods and services are largely public in nature and therefore depend to a large extent on public funding. However, prioritization of public investment and incentives to the private sector for forestry development has been low partly as a result of low valuation of forestry goods and services leading to very slow growth of the sector. This has sometimes accounted for the increased utilization of the forest resources beyond its capacity to sustainably be replenished especially due to the fact that increased population and urbanization are largely dependent on these resources. In forest management, women's traditional roles (e.g., collecting water, growing food, etc.) are particularly crucial in drylands in terms of natural resource management and food security. Men have usually been responsible for decision-making and planning of farming activities especially where land is productive with high economic returns, but with the increasing land degradation, they leave the degraded areas to look for jobs in urban areas, leaving women to assume new roles and responsibilities on the farm. In such a changing context, it is fundamental to be aware of the obstacles hindering full participation of disadvantaged groups, including women in the adverse climate change conditions (Figs. 2 and 3).

Kenya has cited climate change as one of the most serious challenges affecting achievement of its development goals as described under Vision 2030. Toward this end, in 2010, Kenya developed a National Climate Change Response Strategy (NCCRS) followed by the National Climate Change Action Plan (NCCAP) in 2012, which recognized the importance of climate change impacts on the country's development and identifies significant adaptation measures in various sectors of the economy. However, there has been lack of gender-sensitive targets and indicators purposefully set to track progress. There is also need for capacity-building with respect to climate change and its implications for achieving Kenya's gender and development targets. Climate risk management efforts could equally be strengthened by improving understanding of the implications of climate change for Kenyan women and other vulnerable groups, deepening analysis of how to develop and implement adaptation measures that minimize adverse impacts on these groups, and integrating this knowledge into policy and program implementation. Creation of this understanding will likely need to be supported by extensive research and more awareness-raising with policy-makers and experts in this field.



**Fig. 2** Displaced family moving to new place for settlement due to drought extreme in Marsabit County. (Photo: Irene Ojuok)



**Fig. 3** Women practising FMNR in Laisamis, Marsabit County. (Photo: Irene Ojuok)

Farmer-managed natural regeneration is a low-cost, sustainable land restoration technique used to combat poverty and hunger among poor subsistence farmers in developing countries by increasing food and timber production and resilience to climate extremes. It involves the systematic regeneration and management of trees and shrubs from tree stumps, roots, and seeds. World Vision has successfully implemented FMNR as a sustainable forest management approach among communities with tremendous uptake by communities especially in ASAL areas due to the sustainable benefits derived from the tree management systems. Among the tree based value chains are like sale of fuelwood, pasture bulking, and beekeeping which are some of the drivers identified that have motivated farmers to increase restoration efforts due to increased returns from wood and non-wood products. The main beneficiaries of this approach are those who depend more on tree resources: farmers, herders, and particularly women and children who harvest wood and non-timber forest products, which are based on documented economic values of FMNR.

There is, however, a need for in-depth analysis and dissemination of findings on the role of women in natural resource management with focus on drivers of women participation on FMNR for increased climate change resilience in ASAL counties of Kenya. In every society, there are marginalized groups, often including women and children, people with disabilities, and minorities. External parties can play a critical role in opening the eyes of all to the benefits of inclusion and in facilitating positive change sensitively hence need for this chapter in the climate adaptation hand book.

The case study for this chapter draws on World Vision that has wealth of experience in implementing FMNR approach which has been successful in different contexts in Kenya over the last 8 years including in semiarid areas. Between 2018 and 2021, World Vision Kenya (WVK) in partnership with Northern Rangeland Trust (NRT) and Stockholm Environment Institute (SEI) will be implementing a project dubbed Integrated Management of Natural Resources for Resilience in ASALs (IMARA). The goal of the project is toward increasing resilience of about 35,000 marginalized households to climate change-related shocks through diversified livelihoods and improved natural resource management and use in the ASAL Counties of Isiolo, Laikipia, Marsabit, and Samburu through funding from SIDA. The key objectives are as follows: (1) secure livelihoods and strengthened market systems (including for women and youth) that support sustained management of natural resources; (2) sustainable management and rehabilitation of land, forest, and water sources for strengthened ecosystem services; and (3) strengthened governance systems and structures for sustainable NRM at community, county, and national levels. As part of baseline and program intervention mapping, a gender and social inclusion assessment were conducted in the target program area to establish key sociocultural, economic, political, and technological issues that affect participation of women and youth. This is in line with the Swedish Development Cooperation Strategy for Kenya (2016–2020) which includes a focus on “A better environment, limited climate impact and greater resilience to environmental impacts, climate change and natural disasters.”

To complement these objectives, the proposed case study will be limited to identifying the key factors that drive or bar women participation in adoption of FMNR approach for climate resilience in Marsabit County. The findings will be used to develop strategies to effectively and meaningfully engage women in all stages of program implementation cycle. The study findings will strive to enhance women,

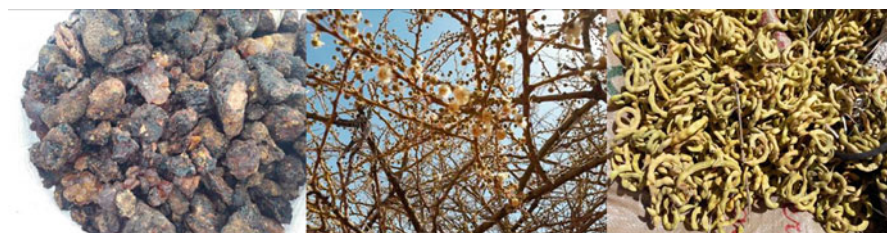
girls, boys, and men in the community participate in a process which allows them to express their needs and to decide their own future with a view to their empowerment in sustainable NRM, livelihoods, and governance domains for increased resilience to impacts of climate change.

The study opted social research using qualitative survey approach. The main method was through interviews using focused group discussions (FGD) and key informant interviews (KII). In this process, KII guide and FGD guides were the main tools adopted for use during the research. The sampling was purposive since it was intended to get information from targeted audience with knowledge on natural resource management and FMNR approach. The interviews entailed for ten sets of respondents (three FGD comprising women only, men only, and mixed group of men and women of different age groups, KIIs including two government officers from environment and agriculture departments, woman FMNR champion, youthful male and female practicing FMNR, World Vision staff implementing the project in Marsabit, and a local chief). An interpreter from the local community supported translations during the interviews due to language barriers in some instances. Summary tables based on the study themes were employed for analysis using the QDA Miner Lite version 2.0.6. The analysis results were presented in terms of tables, graphs, and pie charts. Secondary data sources sourced from document review using document review matrix guide aligned with the key study objectives. Observations were conducted during field travels while doing data collection in the villages of Marsabit. Photography was equally used to obtain general status of the landscape encompassing key features, e.g., vegetation and habitat, migrations, human settlement, and human activities, e.g., trade, livestock rearing, land restoration efforts, etc. (Fig. 4).

## Findings and Recommendations

### To Identify Potential Risks Associated with Climate Change and Land Degradation Facing the Communities in Laisamis (Mention the Key Threats, Who Is Most at Risk, Why)

Overall, *extreme climatic conditions* linked to climate change mostly mentioned by the respondents include severe and prolonged drought, increased flood occurrences (El Niño), extreme heat caused by high temperatures, low and irregular rainfall



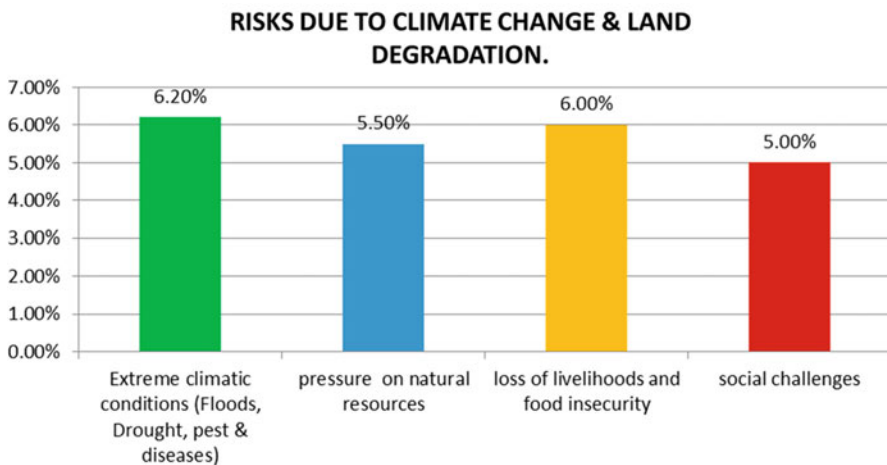
**Fig. 4** FMNR benefits – gums and resins, flowers, and seeds used as livestock feed critical in drought season. (Photo: Irene Ojuok)



patterns, and disease outbreaks, e.g., malaria and diarrhea. In the month of April 2019 (Kenya 2019), seven people were confirmed dead following the outbreak of **kala-azar** vector (sand fly) disease in **Marsabit County mainly** in Laisamis sub-county. This insect is most active in humid environments during the warmer months and at night, from dusk to dawn. According to the World Health Organization (WHO) 14 March 2019 report, this disease which mainly affects the poorest people on Earth is linked to environmental changes such as deforestation, building of dams, irrigation schemes, and urbanization. Environmental management hence cited important in reducing or interrupting transmission of this disease (Fig. 5).

Intensified **pressure on natural resources** is attributed to water scarcity, limited pasture, increased deforestation, limited access to firewood, soil and wind erosion, and along the river beds overharvesting of sand. Risks associated with climate change have also led to **loss of livelihoods and food insecurity** leading to death or poor health of livestock, low crop yields, increased charcoal burning for sale, and loss of wild fruits and seeds/fodder usually consumed by human and livestock during severe drought. Hunger and malnutrition manifest itself in these cases. Some of the social challenges include **displacements/migration; conflict over natural resources; increased crime**, e.g., cattle raiding; **school dropouts; family breakdown; and poverty**. One of the respondents emphasized that during drought “only one out of five children attends schools” hence higher levels of illiteracy in the region. In a men FGD, one respondent expressed threats associated *with morans marrying their women* since the younger men can offer better living conditions than the older ones.

91% of the respondents reported that **women and children are the most at risk** in these circumstances. The reproductive roles undertaken solely by women were emphasized to increase their vulnerability in negative climate change impacts. For instance, when men migrate in search of pasture, women take up full responsibility



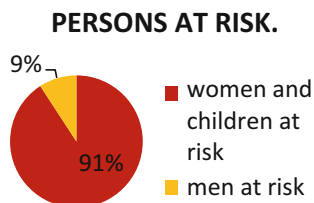
**Fig. 5** Analysis of risks associated with climate change

for households; conflicts due to pressure on natural resources leave women most affected because of their weak levels of defense, and hunger caused by drought deteriorates health of pregnant and lactating mothers including children under five. The men-only FGD confirmed that a *woman had been killed in the process of protecting her children* when an enemy attacked their household and the man had migrated with large herds in search of pasture. Limitations on decision-making and utilization of valuable resources that can help support them while in need, e.g., livestock, land, and large-scale sale of tree value chains, are mainly men-dominated, and they shared justifications to this. This emphasizes the critical need of enhancing women participation in sustainable natural resource management while exploring the potentials FMNR has in increasing their resilience to climate change (Fig. 6).

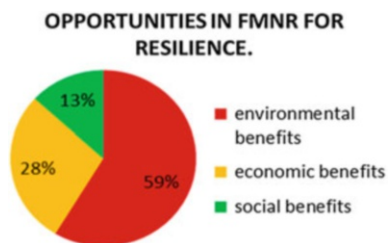
**Assess the Opportunities FMNR Has in Increasing the Resilience of the Communities to these Risks (Define FMNR, Its Key Benefits from an Environmental, Economic, Social View, etc.)**

The FGDs and KIIs were sought to explore FMNR benefits in resilience-building among the communities (Fig. 7). Adaptation and mitigation opportunities came out strongly with environmental conservation benefits leading, followed by enhanced availability of pasture for livestock and increased food security which aside from addressing the domestic household needs also offered better economic opportunities. Respondents confirmed that FMNR is an **adaptable approach to land restoration** especially in an ASAL context since it is easy to apply and inclusive (done by men, women, people living with disabilities, and children) and has high success rates,

**Fig. 6** Analysis of the most affected gender in climate change risk scenarios



**Fig. 7** Opportunities FMNR provide for enhanced resilience



community bylaws, and regulation control in tree harvesting, thus reducing pressure caused by overharvesting of trees. Invasion of *Prosopis juliflora* (*mathenge*) in Marsabit is a menace, but FMNR management practices applied to this species have enabled better management. Increased **access to high-value indigenous trees**, e.g., wild fruits and Acacia pods, was cited by the pastoralists especially women as a critical feed for human and livestock especially during severe drought and for medicinal purposes. Often, women are the repository of extensive botanical knowledge since they know the traditional uses of many species. One woman says “Such trees are a mystery to us, without which we perish. Acacia tree pods and flowers can feed livestock for 10 months in scarcity of grass.” **Less migration of people and livestock** is experienced where FMNR is practiced due to availability of pasture/fodder throughout the year. This reduced the burden of women being household heads during prolonged drought. They also mentioned the link between **improved health and productivity of their livestock** which ultimately addresses food security and economic empowerment since their livestock fetches higher market rates and increased milk and meat production offers nutrition needs as well as excess for markets. FMNR strengthens knowledge in tree-based value chains, thus enhancing **diversification of livelihood opportunities** from wood and non-wood forest products (NWFPs), e.g., trade in gums and resins, honey, gum arabic, firewood, acacia pods, wild fruits, etc. Respondents also brought out the FMNR social aspects in which cultural and religious attachments to specific species of trees enhanced their protection and management, e.g., there are species used during marriage, circumcision, and sacred events.

## What Are the Roles of Men and Women in Uptake of FMNR

The objective explored the different roles played by men and women in the uptake of FMNR practice. This was based on the domestic chores undertaken by men and women in the family and community setup. It was evident that women are directly responsible for **care and management of trees** due to many derived benefits they accrue from the trees that enable them run their families. In all the mentioned roles of women, protection and use of the tree resources were most significant. Men, on the other hand, mainly offer **administrative roles in control of the natural resource**. Out of the nine roles played by men in uptake of the practice, five are mainly in management and control of use of the resources. Both men and women have equally **economic interest** role rates in the practice of FMNR. **Trade** in livestock, gum and resin, seeds, and wild fruit collection is done by both. **Management and utilization** of tree resources especially in large scale is reserved for men. It was interesting to note that **development and enforcement of bylaws or regulations** for environmental protection significantly sit on men (Fig. 8).

Generally, women often manage sheep and goats as they tend to be kept closer to the homestead. Women also tend to be left responsible for the home herd of cattle and camels when men take others on migration. As such, women's roles in livestock and environmental management should not be underestimated, and often their

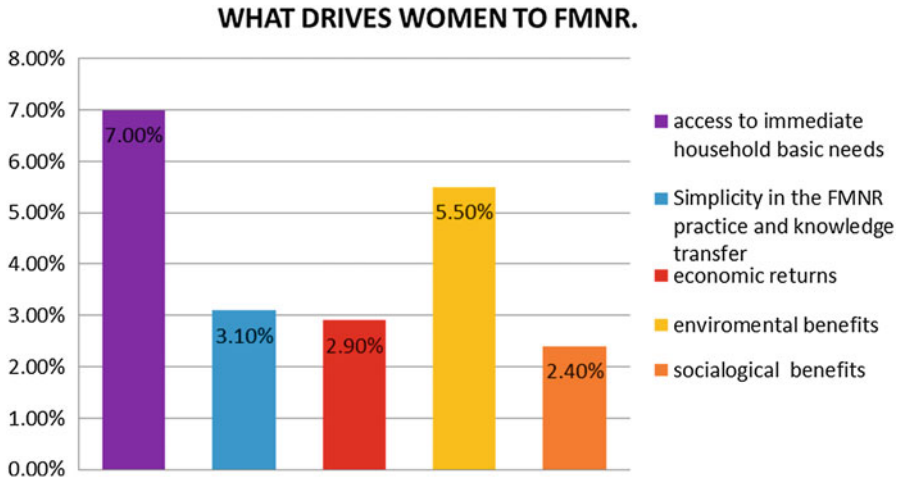
No.	Men	Women	Both Men and Women
1.	Decision making on management and use of trees	Taking care of trees	Pruning and thinning of trees
2.	Control over the tree resources	Feeding the family and small stock from tree products	Offer education on environmental conservation
3.	Administration of justice especially for tree offenders	Putting up shelter for the family using tree branches	Harvesting of Wood and NWFPs
4.	Only men practise bee keeping	Creating awareness and trainings to other women on FMNR	Trading in wood and NWFPs
5.	Guide ceremonies in which specific trees are used	Reporting tree offences to men/elders	
6.	Educating young boys on importance of taking care of the earth during initiation ceremonies e.g. circumcision	Small scale harvesting of Wood and NWFPs (firewood, acacia pods, wild fruits, herbs, gums and resins)	
7.	Long and short distance grazing for large herds especially during drought	Trading in wood and NWFPs to feed the family	
8.	Large scale Harvesting of trees especially mature/very old ones	Short distance grazing especially for small stock	
9.	Developing bylaws/regulations for tree management and use	Protecting and watering of trees e.g. the wildings	

**Fig. 8** Roles of men and women in uptake of FMNR

knowledge on livestock as well as grazing areas, migration routes, and water points is rich. Women and men typically have different objectives for keeping animals, different authorities and responsibilities, and different abilities to access and use new information and improved technologies. These differences may lead them to have different priorities regarding investments in the adoption of new technologies and practices and/or different ideas about how best food and livelihood security can be attained through embracing FMNR.

### What Drives Women to Participate in or to Adopt FMNR

From both FGD and KII interviews, FMNR ability to enhance **access to immediate household basic needs**, e.g., firewood, feeds (for human and livestock), building and fencing materials, and beddings, was cited as the most important driver to women participation in uptake of this practice (Fig. 9). Continued deforestation in Laisamis has led women walking long distances in search of firewood; one woman reported walking 8 h (to and fro) to collect water and firewood from far off hills. Acacia pods offer nutritious feed for livestock especially during drought when pasture is limited, wild fruits have been a significant source of food in households, both seeds and wild fruits are also sold in the market, and women are mostly involved in this business. Alongside this, **economic returns from sale of products** from the environmental services accrued as a result of FMNR boosts women to participate in savings and loaning schemes, thus enabling them to expand and diversify their businesses/livelihood opportunities and increase their income levels. As they easily access basic immediate need through FMNR, women have more time to explore participating in other interventions like poultry keeping and kitchen gardening for nutrition and markets. One of the respondents noted that “Women

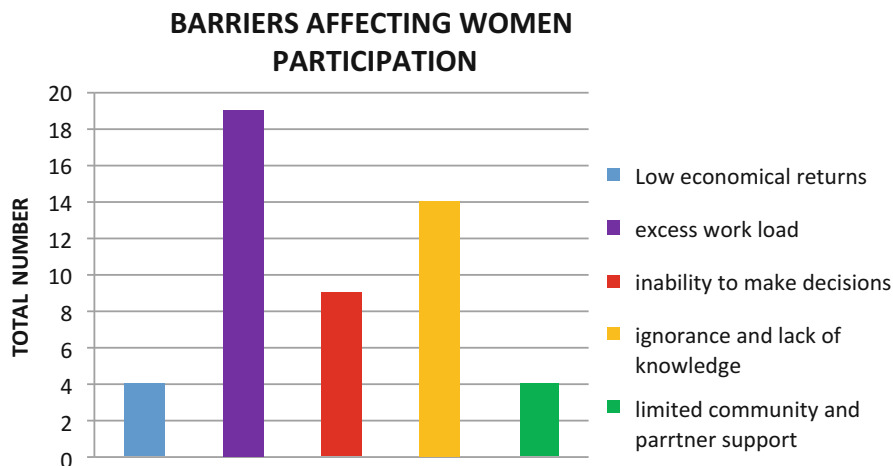


**Fig. 9** Key drivers of women uptake and participation in FMNR

will go to great lengths to extract resources they need to take care of their families including entering dangerous insecure areas such as no-go zones which put them at risk of rape, kidnapping and killing.” Improved health of livestock enhances the prices and increases milk production which is valuable to women. **Ease in application and transferring of knowledge** and practice of FMNR including its **social benefits was ranked third** in women drivers in uptake of FMNR. Participants affirmed the low-cost approach would best suit women since they are most vulnerable, and the more expensive an approach, the lesser application they would have of it. Majority of women in the region are illiterate; hence, the simplicity in the practice enhances women participation. **Environmental benefits** from FMNR were equally a factor since severely degraded landscapes are key threats to women because this deprives them access to basic ecosystem services. Marsabit is generally a dry place with high temperatures; FMNR increases tree cover that provides shade required by human and livestock. Women appreciated the importance of shade for resting and relaxing after daily chores. In some instances, goats have equally died due to prolonged exposure to very high temperatures, thus underpinning the importance of trees offering shade. Bare land exposes the community to excessive dust which further than contaminating food and causes eye and respiratory problems. Strong winds in the area have led to destruction of property; hence, trees play an important role as they serve as wind breaks.

### **Key Barriers Affecting Women Participation in FMNR**

The main barrier limiting effective women participation in uptake of FMNR mentioned by all the respondents is **excess workload** on women which affects their concentration and consistency in rollout of FMNR since their attention is



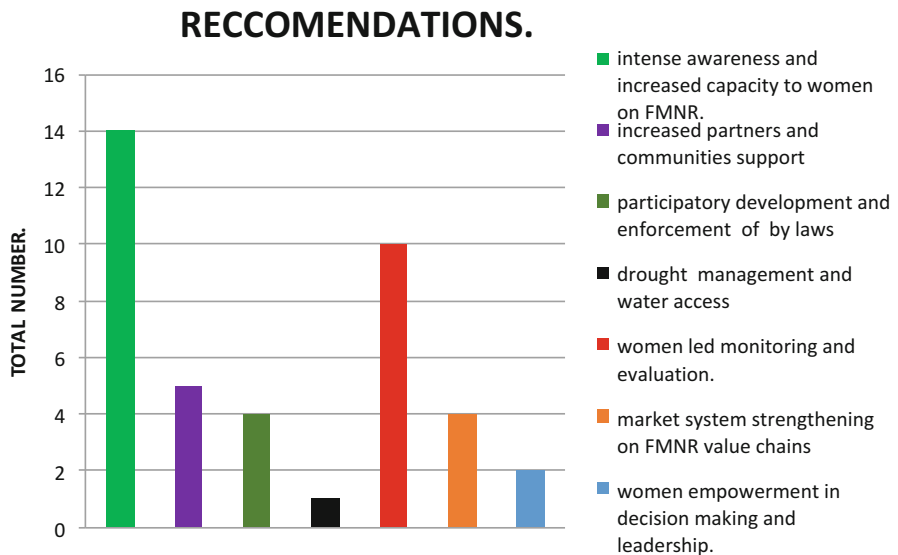
**Fig. 10** Barriers affecting women participation in FMNR

diverged to addressing domestic chores and reproductive roles at household (Fig. 10). Severe drought and increased water stress necessitate this challenge overburdening women the more. **Ignorance and lack of knowledge** was cited as threat to uptake of this approach since it is likely to limit transfer of knowledge and skills. Most women in this community are illiterate, for instance, in women-only FGD, 90% of the respondents were only exposed to informal education and could only speak their local language, hence causing communication barriers in new knowledge transfers. Inability to make full decisions over management and utilization of tree resources as well as livestock that have direct linkage to success of FMNR was equally a challenge the women faced as observed by the respondents. Women's subordinate position in society, and their diminished access to information, education, and training, affects their participation in decision-making and public life. This is sometimes attributed to the cultural norms like overstocking by men depicting wealth and pride. Land ownership also rests on men; hence, women have limited power to make decisions on resources on land. Traditional institutions that offer guidance and leadership are mainly comprised of men; in fact, council of elders which is the highest traditional institution is purely composed of men. Women also need the security of knowing that they will have equal decision-making power in how resources and incomes from FMNR work will be used. This is especially important for women-headed households. **Low economic returns** and long-term benefits expected from trees and NWFPs minimize the interest of women in land restoration efforts including FMNR. The respondents acknowledged the many income sources from tree-based value chains, but the low market prices make the venture not worthwhile. For instance, they cited case of gums and resins which cost 200/kg in their locality, yet the same goes for 1000/= in the urban areas. This makes them feel exploited. Lack of organized market systems for the FMNR value chains limits women's return on the investments in the practice, thus

derailing their efforts. **Vastness of the area and limited transport** means makes it even more difficult for knowledgeable people to create awareness of the approach due to logistical challenges. **Minimal community and least concerted partner support** to address this challenges derails passion among the existing women champions who strive to promote uptake of FMNR in the community.

### Recommendations for Enhancing Women Participation in FMNR Uptake

**Intense awareness and improved capacity for women** to participate in FMNR was identified as most critical need in influencing their uptake of this approach (Fig. 11). This could be achieved through trainings, exposure to successful sites, and increased access to quality germplasm required by women. Gaps in effective monitoring and evaluation of projects have previously affected success of the projects; the respondents emphasized the need to have **community-led monitoring, evaluation, and learning model** for FMNR approach which are women-led, inclusive, and responsive. This will ensure women own this approach and integrate it in their daily activities. For instance, women are main beneficiaries of firewood; it’s easy for them to include pruning and protecting of trees as they harvest firewood. The respondents also noted low **involvement of community and partners** in environmental conservation initiatives which then becomes a barrier to success of implementing this approach since it requires everyone. **Drought management and increased water access** is key in reducing pressure



**Fig. 11** Key recommendations for women participation in FMNR

women are exposed to in addressing household needs which would then give them time to get fully involved in FMNR activities. This continues to emphasize the need to invest more in adaptation and mitigation efforts to improve community resilience to climate change effects. More efforts are also required to **ensure women meaningfully participate in decision-making and have leadership roles** in natural resource management as they are the most at risk and have the ability to offer best solutions. In circumstances where women and men have equal access to productive resources, control over those resources is usually vested in men. Across all the above objectives, economic returns have been mentioned driver to investments by community in land restoration. While interrogating this further in the recommendations, respondents cited the need to strengthen the **market systems and value chains along FMNR** and other sustainable natural resource management approaches as this will attract more people to invest in the models. There are very many opportunities in FMNR that both address mitigation and adaptation which economic incentives would propel greatly. “Why can’t private sector and research actors explore marketing or adding value to acacia pods from acacia tree that is proved to enhance milk production and health in goats and is the main livestock feed of all pastoral communities that take them from one drought season into the rainy seasons? The market for this product is disorganized hence no adequate return on investment, yet this can be big driver for pastoralists to bring back acacia trees on land which provide other multiple benefits” reiterates one of the respondents.

---

### **Limitation of the Study**

While the case study has established significant findings and recommendations in enhancing women participation in uptake of FMNR for climate resilience, it’s important to note that the limited duration in implementation of such findings may not yield to desired outcomes. The study also targeted a narrow geographical extent with small population applying the quantitative and quantitative data collection methods to derive the results; hence, the outcomes need to be understood within this scope. Intended, IMARA project evaluation in 2021 will additionally establish the contributions of these findings to the outcome of women participation in FMNR within Marsabit County. Additionally, it is important to note that in many communities living in ASALs, the status of women and girls is subordinate to that of men and boys. Key assets and resources, such as land, livestock, water, and cash, are generally controlled by older men rather than by women or youth, reflecting the subordinate position of women in society and the cultural limitations placed on their public role. The welfare of women and girls is also directly threatened by environmental problems, which increase the pressures of providing for the household, particularly water and fuelwood collection. Further studies are hence recommended in this field to bridge the gender gaps that continue to challenge women participation climate resilience initiatives or programs.



## Conclusion

About 80% of Kenyan women spend about 1–5 h per day per household looking for fuelwood (p. vi), and in some rural locations (particularly in the ASALs), they spend 3–5.25 h a day collecting water (p. 20). Climate disasters can increase women's household responsibilities and cause disproportionate economic losses. During periods of drought, especially in the ASALs, women and children need to walk greater distances to fetch water and fuelwood. The household responsibilities of women can also increase, even more so if the able-bodied male members of a household leave in search of economic opportunities. Greater resource scarcity can also increase the likelihood of women and children being affected by conflict and violence. Women are at greater risk as well during periods of flood, when the occurrence of malaria, cholera, and dysentery – to which pregnant women and children are more vulnerable – can increase, particularly in areas where access to health care is inadequate. Despite women's multiple burdens, they have proved their capacity for effective collective action at the local level and shown that investment in their empowerment generates positive multiplier effects across communities in ways that improve human welfare.

IMARA program interventions on natural resource management for livelihoods seek to integrate gender and conflict prevention and prioritize sustainable, market-based solutions to address the persistent challenges. The efforts will transform the lives of communities and households in the four target counties and revitalize/preserve rangeland assets for the benefit of future generations especially women who are mostly affected by the negative impacts of climate change. According to the County Integrated Development Plans (CIDP) for Marsabit 2017, one of the key social problems in Marsabit County is high gender inequality as women and youth participation in development is low and there are few women and youth involved in leadership and decision-making; traditional and cultural practices are dominant. It is on this basis that the case study sought to investigate the factors affecting women participation in uptake of FMNR for climate resilience with the below summarized conclusion:

- There is evidence of risks associated with climate change linked to climate variability (drought, floods, high temperatures, disease outbreak), increased pressure on natural resources leading to resource-based conflicts, loss of livelihoods intensifying poverty, and social disintegrations causing lack of cohesion among communities. These increase vulnerabilities of communities, and 91% of the respondents noted that women and children as the most affected.
- Environmental, economic, and social benefits proved greatest opportunities FMNR has in increasing resilience of farmers to impacts of climate change.
- Women were cited to be more involved in the actual restoration and exploitation of the tree resources due to reproductive roles which are heavily dependent on sustainable landscapes. On the other hand, men are mainly into overall administration and management of the resources. This means women invest in what they have limited gains especially when there are huge returns.

- Main drivers to women participation in FMNR included access to immediate practical needs, environmental benefits, simplicity and adaptability of the approach, and economic and social benefits. These are in order of priority.
- The greatest barrier threatening women participation in FMNR is excess work load on women in the household following limited efforts to address the burden of women especially in ASAL communities. Ignorance attributed to high illiteracy levels, low decision-making powers, low economic returns, and inadequate partner and community support limits women participation.
- Recommendations, intense gender-responsive FMNR campaigns, women-led monitoring, evaluation and learning, partner and community support, market systems strengthening for FMNR value chains, participatory development and enforcement of bylaws, women empowerment in leadership and decision-making, and finally drought management and increased water access (Figs. 12, 13, 14, 15, 16, and 17).



**Fig. 12** FGD participants in sampled sessions. (Photo: Irene Ojuok)



**Fig. 13** Typical house in Laisamis constructed by woman and children enjoying on tree. (Photo: Irene Ojuok)



**Fig. 14** Bare land that is severely degraded in Laisamis and another on FMNR practice. (Photo: Irene Ojuok)



**Fig. 15** Alternative livelihoods women engage in where FMNR is working with their support. (Photo: Irene Ojuok)



**Fig. 16** On the left the “Tony Rinaudo” tree – as the community call it in July 2019. On the right, the same tree in January 2020, Iltepes women group FMNR site in Korr, Marsabit County. (Photo by Wesley Koskei WVK Communications Officer)



**Fig. 17** Tony Rinaudo right livelihood laureate and founder of FMNR on the right with communities and World Vision staff in the field demonstrating FMNR practice, on the left is FMNR integrated with reseedling in Laisamis, Marsabit County. (Photo by Wesley Koskei WVK Communications officer)

**Acknowledgments** Special appreciation to SIDA for sponsoring this program through the International Training Program for Climate change Adaptation and Mitigation with support from World Vision Kenya and World Vision Australia FMNR Hub.

## References

- Coppock D et al (2013) Cross-border interaction spurs innovation and Hope among pastoral and agro-pastoral women of Ethiopia and Kenya. *Rangelands* 35(6):22–28  
[https://www.google.com/url?sa=t&rct=j&q=&esrc=s&source=web&cd=8&cad=rja&uact=8&ved=2ahUKewjkhaiszmiAhWNERQKHcjXBHYQFjAHegQIBBAC&url=http%3A%2F%2Fwww.icpac.net%2Fimages%2Fpublications%2Fadministrative%2FICPAC\\_MAJOR\\_ACHIEVEMENTS\\_2018.pdf&usq=AOvVaw3xGTmRPrVJUfb4IFKd4nL4](https://www.google.com/url?sa=t&rct=j&q=&esrc=s&source=web&cd=8&cad=rja&uact=8&ved=2ahUKewjkhaiszmiAhWNERQKHcjXBHYQFjAHegQIBBAC&url=http%3A%2F%2Fwww.icpac.net%2Fimages%2Fpublications%2Fadministrative%2FICPAC_MAJOR_ACHIEVEMENTS_2018.pdf&usq=AOvVaw3xGTmRPrVJUfb4IFKd4nL4)  
<https://www.the-star.co.ke/.../2019-04-24-seven-people-die-of-kala-azar-in-marsabitfmmnrhub.com.au/wp-content/uploads/2013/09/Rinaudo-2007-Development-of-FMNR.pdf>  
<https://www.unenvironment.org/news-and-stories/press-release/livelihoods-development-critical-post-conflict-peacebuilding>  
 ICPAC and the World Food Programme (WFP) Atlas (2017) Atlas of Climate Risk and Food Security in the Greater Horn of Africa Region  
 Nicholson SE (2001) Climatic and environmental change in Africa during the last two centuries. *Clim Res* 17:123–144  
 Republic of Kenya (ROK) (2000) National gender and development policy. Ministry of Gender, Sports, Culture and Social Services. Retrieved from <http://bit.ly/P1CtN1>

**Open Access** This chapter is licensed under the terms of the Creative Commons Attribution 4.0 International License (<http://creativecommons.org/licenses/by/4.0/>), which permits use, sharing, adaptation, distribution and reproduction in any medium or format, as long as you give appropriate credit to the original author(s) and the source, provide a link to the Creative Commons license and indicate if changes were made.

The images or other third party material in this chapter are included in the chapter's Creative Commons license, unless indicated otherwise in a credit line to the material. If material is not included in the chapter's Creative Commons license and your intended use is not permitted by statutory regulation or exceeds the permitted use, you will need to obtain permission directly from the copyright holder.





# Climate Change Adaptation and Community Development in Port Harcourt, Nigeria

# 135

Julie Greenwalt, Michael Dede, Ibinabo Johnson, Prince Nosa,  
Abi Precious, and Barbara Summers

## Contents

Introduction .....	2776
Port Harcourt, Nigeria .....	2777
Communities First: Effective Community-Led and Data-Driven Change .....	2779
Community Mapping and Data .....	2780
Documenting Sanitation and Exacerbating Conditions .....	2783
Data and Media Advocacy .....	2787
Climate Change in Nigeria .....	2788
Climate Change Adaptation: Voices from the Community and Global Recommendations ...	2791
Global Recommendations for Advancing Adaptation .....	2791
Port Harcourt in Focus: Climate Change Adaptation Awareness and Action .....	2792
Climate Change Impacts Observed .....	2795
Adaptation Actions .....	2796
Proposed Adaptation Solutions .....	2798
Conclusions and Recommendations .....	2798
References .....	2800

---

This chapter was previously published non-open access with exclusive rights reserved by the Publisher. It has been changed retrospectively to open access under a CC BY 4.0 license and the copyright holder is “The Author(s)”. For further details, please see the license information at the end of the chapter.

---

J. Greenwalt (✉)  
Go Green for Climate, Amsterdam, Netherlands  
e-mail: [julie@gogreenforclimate.com](mailto:julie@gogreenforclimate.com)

M. Dede · I. Johnson · P. Nosa · A. Precious  
Chicoco Collective, Port Harcourt, Nigeria

B. Summers  
CMAP, Port Harcourt, Nigeria  
e-mail: [barbara@cmapping.net](mailto:barbara@cmapping.net)

---

**Abstract**

Port Harcourt, Nigeria, as with many cities in Africa, is already experiencing impacts from climate change while also facing development challenges and compounding vulnerabilities. There is often a gap between the adaptation recommendations of academia and international organizations and the conditions needed to achieve these recommendations given the realities on the ground in cities with vulnerable populations, pressing challenges, and minimal capacity. This gap can make it difficult to translate theoretically persuasive plans and guidance into practically sustainable actions. This chapter builds on the experience of CMAP, a Port Harcourt-based NGO leading participatory mapping, community media, and public space design programs in the city's informal waterfront settlements. Drawing on the perspectives of Chicoco Collective, the youth-led volunteer network which CMAP supports, and the datasets that they have built, the chapter explores local awareness and skills for climate change adaptation. This chapter concludes with recommendations relevant for Port Harcourt and similar African cities to build on such local skills and experiences and advocates for a partnership-based approach that brings together adaptation professionals and community-based actors for more effective critical analysis of local conditions and prioritization of actions to meet the development and climate change needs of local communities.

---

**Keywords**

Community development · Port Harcourt · Nigeria · Flooding · Community data · Awareness raising · Informal settlements

---

**Introduction**

There is growing global awareness and urgency about the need to accelerate action to adapt to climate change. Many cities and local communities, especially in Africa, are already experiencing the impacts of climate change, and risks and vulnerabilities are increasing. This chapter focuses on Port Harcourt, Nigeria, which is a secondary city in the most populous country in Africa and the oil capital of Nigeria. The chapter will share data and information gathered by CMAP, a local NGO, and Chicoco Collective, the youth-led volunteer network that it supports, to explore the risks and vulnerabilities in Port Harcourt, as well as the ongoing work of CMAP and the perspective of local communities, to identify some of the key challenges and to propose recommendations for how Port Harcourt and similar African cities could accelerate action on climate change.

The chapter also explores the gap between the adaptation recommendations of academia and international organizations and the conditions needed to achieve these recommendations given the realities on the ground in cities with vulnerable populations, pressing challenges, and minimal capacity. This gap can make it

difficult to translate theoretically persuasive plans and guidance into practically sustainable actions. However, a partnership-based approach that brings together adaptation professionals and community-based actors for more effective critical analysis of local conditions and prioritization of actions can help to advance both the development and climate change adaptation needs of local communities.

This chapter presents findings from focus groups, mapping, surveys, and transect walks undertaken by CMAP and Chicoco Collective related to community development, vulnerability, and climate change awareness. It also provides a brief introduction to Port Harcourt, climate change in Nigeria, and a brief review of some of the latest literature and recommendations produced at the global level on adaptation to climate change in cities, Africa, and informal settlements.

## Port Harcourt, Nigeria

Port Harcourt is the capital of Rivers State and is located in the Niger Delta region. The city lies at the mouth of the River Bonny. It is located approximately 25 km from the Atlantic Ocean and is situated between the Dockyard creek/Bonny River and the Amadi creek. It lies at an average altitude of about 12 m above mean sea level, although the waterfront communities tend to be below 4 m (Fig. 1).



**Fig. 1** Map of the Niger Delta highlighting Port Harcourt's location 25 km inland from the Atlantic Ocean (created by CMAP in March 2020 using QGIS and data from Rivers State Office of the Surveyor General)

Port Harcourt was founded in 1912 during the colonial era as a railroad terminus and deep-water port for exporting coal, then later, oil and gas, after their discovery in the late 1950s in the Niger Delta. The oil and gas sector continues to dominate the local formal economy. However, despite the economic wealth generated in the region, many people in the city and state live in impoverished conditions. IMF-imposed structural adjustment in the 1980s and 1990s saw Nigerian cities such as Port Harcourt simultaneously grow and physically deteriorate. Even as they absorbed newcomers, they often lacked the resources to provide appropriate infrastructure and services to growing populations. With an economy so closely connected to resource extraction, long term plans are vulnerable to disruption by oil and gas-market downturns, as well as changes in state government. Historically, a drop in oil prices has corresponded to a shortage of resources for housing, water supply, security, or waste management in Port Harcourt and is often linked with the proliferation of informal settlements (Bloch et al. 2015). A series of abandoned Port Harcourt master plans and infrastructure projects, most notably the monorail, which starts and ends abruptly and has never been used, are testament to the absence of sustained urban planning and action as a result of low economic and political investment.

Despite its current ranking as one of the largest economies in Africa, Nigeria has failed to translate growth in output into an increase in formal employment, and this failure has resulted in significant underemployment. This is an even greater challenge for the country's growing share of youth. Fifty-five percent of the population is under the age of 20 (World Bank 2016). This nationwide trend is evidenced in employment rates in Port Harcourt where not only has youth unemployment increased, but is coupled with significant underemployment and a lack of productive opportunities for young workers. For many youth, participation in the illegal/informal crude oil refining process in the creeks around the city is seen as one of the few – but most lucrative – options in the local economy. Further exacerbating the issues, the city once known as the Garden City is now characterized by degradation of waterways, soil, and air largely due to the oil and gas industry (both legal and illegal).

Nigeria is a federal state with much of the governance power resting in state governments which have ministries for environment, urban development, education, etc. Despite this decentralized governance system, active city governments are largely nonexistent, and state governments have primacy over physical development in urban areas. This is the case in Port Harcourt.

The city of Port Harcourt has an estimated population of over 1.8 million, making it the sixth largest city in Nigeria and the largest in the South-South region (OECD/SWAC 2020). The climate is tropical monsoon with an annual mean maximum temperature 30.9 °C and mean minimum temperature 22.6 °C ([www.wmo.int](http://www.wmo.int)).

As noted in the 2009 Max Lock Centre study by Theis et al., spontaneous and uncontrolled physical growth driven by rapid urbanization in Port Harcourt over the last several decades has increased the settlement of the areas alongside swamps in the waterfront. Faced with high-cost inner-city rentals and a shortage of housing, many new urban dwellers are forced to settle in high-risk neighborhoods exposed to



flooding and the adverse effects of climate change. These waterfront communities are now the largest informal settlements in the city, with some population estimates of over 480,000 people (Theis et al. 2009). While they have varying levels of development, with little to no government intervention or service provision, they can be characterized as lacking in many basic services including sanitation, water, and waste disposal. These communities also regularly face the threat of forced eviction with several large-scale demolitions taking place in 2009, 2012, and 2016.

---

## **Communities First: Effective Community-Led and Data-Driven Change**

Collaborative Media Advocacy Platform (CMAP) has been working with residents of informal waterfront communities in Port Harcourt for over 10 years. CMAP began as an informal association motivated by building both local and global awareness of, and halting, massive forced evictions in waterfront communities. The project's animating impulse was the response of community members to the camera of the organization's now-project director when he found himself in the middle of a large-scale forced eviction. In the middle of the demolition, residents rallied around the camera, protecting it from the police and directing what it filmed.

In 2009, the then Governor of Rivers State announced the planned demolition of all the city's waterfront settlements. These settlements were not represented on municipal maps. They featured in the city's development plan only as undifferentiated zones marked for "clearance" through "major relocations." The resultant forced evictions and demolitions triggered not only widespread displacement, but also a conflict that threatened to become militant. In response, a group of local activists and international campaign organizations started to support mobilization of these marginalized waterfront communities, making visible the violence and disregard of state agencies through documentary photography, film, and recorded testimonies.

Following initial campaigning and legal advocacy work, there was a systematic broadening of engagement with different forms of representation – from the cinematic to the cartographic, from the voice on the street to the voice on the airwaves, and from architectural design to legal representation – and a strategic exploration of how they could be layered to support the struggle of Port Harcourt's waterfront settlements to be seen and heard. After several years of ad hoc activities, programs were solidified into the Human City Project, led by CMAP and a local community-registered trust. The project's programs – Chicoco Cinema, Chicoco Radio, Chicoco Sound, Chicoco Maps, and soon Chicoco Solar – are the focus of the Chicoco Collective. In its over 9 years of work, the project has established highly trained community mapping and media teams, including reporters, writers, presenters, broadcasters, filmmakers, photographers, actors, musicians, surveyors, and technical producers, with the capacity to manage a community radio and music studio.

The Chicoco Maps program, which launched as a direct response to communities not being recognized on any map or in official statistics, focuses on building the



**Fig. 2** Household unit map of Ibiapu Polo Waterfront Community (CMAP 2018)

capacity of young waterfront residents to put their communities on the map, capture the information to tell their story on their terms, and generate the necessary data to negotiate with government authorities. Over the past 6 years, the volunteer community cartographers have created base maps of six waterfront communities and, for three of those communities, have developed the most thorough dataset on any community in the greater Port Harcourt area. An example of one of the community maps can be seen below which details structures and land use (Fig 2).

Their work has involved indexing every building, as well as conducting household surveys, gathering detailed community-level data on population, land use, employment, health, and service provision, among others. This data is fed into an encounter and exchange program in which civil society, government representatives, and community members are brought together in solution-focused discussions facilitated by project participants around their data and map outputs in each community.

## Community Mapping and Data

The Chicoco Mapping team carried out detailed demographic and structure/infrastructure surveying of three waterfront communities. The team was able to survey

**Table 1** Demographics of three waterfront communities in Port Harcourt: Ibiapu, Darick, and Amatari Polos (CMAP 2018)

	Ibiapu Polo	Darick Polo	Amatari Polo
Population	4,079	1,922	1,846
Number of households	969	447	504
Population density (ppl/km <sup>2</sup> )	73,833	35,900	67,000
Number of businesses	126	69	97

77–80% of households in each community, which gave a representative number of responses to extrapolate total population as well as to understand the major trends in the community. The following overview statistics of Ibiapu Polo, Darick Polo, and Amatari Polo communities can be seen in Table 1.

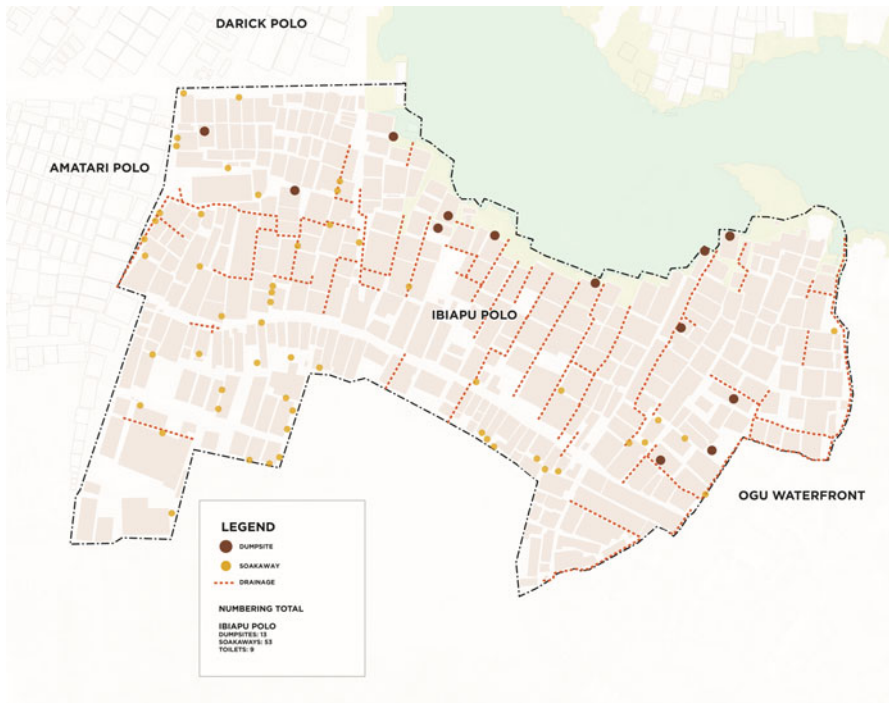
These communities share similar topographical characteristics with other waterfront communities throughout the city, being 10–15 m below the rest of the city on land reclaimed from mangroves. Amatari Polo is the oldest of the three, settled over 60 years ago. Ibiapu Polo is approximately 40 years old, while Darick Polo is less than 20 years old and is the only community that has been sand-filled. The others are built on “chicoco” mud, extracted from the mangroves. Despite the majority of residents having lived in their communities for 5 years or longer, households predominately reported having only informal or community-granted documentation of rent or ownership.

All three communities have a young population, with over 50% of residents under the age of 25. Unemployment rates were reported as 10–12%, but it is likely that actual unemployment rates are higher, with many people reporting self-employed and not employed full-time. These waterfront communities are all managed by an Okrikan system of community leadership led by an elected community chairman and supported by a range of committee members including a woman leader, youth leader, sanitation chairman, light chairman, etc.

While the community mapping project was initially focused on collecting data for preventing forced evictions or negotiating with the government on security of tenure or service provision, it is a useful basis for understanding some of the existing climate change impacts or highlighting potential vulnerabilities. For instance, the household surveys found that over half of households reported that flooding after a rainfall event restricts their movement. Furthermore, 29% of households reported that they always have to wait a while after it rains before they can leave their home. The chart below highlights the impacts of flooding on individual households (Fig. 3).

Infrastructure networks including roads and pathways, electrical, water, and waste networks have also been documented in detail in the mapping process. This is often the first time community scale infrastructures have been documented. This aggregation of infrastructure often highlights the ad hoc manner in which drainage is implemented in the community and between bordering communities when the various community data are collated. For example, the map below indicates that the drainage network in Ibiapu Polo, one of the neighborhoods intensively mapped and surveyed by the Chicoco team, is not integrated and few of its channels are

**Fig. 3** Households in Ibiapu, Darick, and Amatari Polo reporting the ability to leave their home after a rainfall event. The response options were that yes, they can always leave their home; yes, they sometimes have to wait; or no, they always have to wait for flooding to recede (CMAP 2018)



**Fig. 4** Waste network map of Ibiapu Polo Waterfront Community, CMAP (2018)

ultimately connected to the larger network. These maps can serve as a base for understanding flooding bottlenecks and planning for improvements in each community. Insights into impacts of the poor drainage system and flooding are deepened by the household survey. Between 60% and 78% of households reported that drainage was one of the major problems facing their household (Fig. 4).

Another major problem raised by residents in the household survey was access to drinking water because the majority of households reported needing more than one source of drinking water. The two most significant sources of water reported are sachet water (i.e., water sold in small, sealed plastic bags) and private boreholes/taps outside their house. Less than one third of all households surveyed had access to piped water within their home.

Other issues raised by households in the survey included sewage leakage/lack of toilet facilities and management of solid waste. While these issues may not directly link to impacts of climate change at this time, they are likely to continue to exacerbate the impacts of climate change in these already vulnerable communities.

## **Documenting Sanitation and Exacerbating Conditions**

There have been impacts at the community scale of the mapping work, but more significantly a shift in the citywide development dialogue. An African Development Bank-funded state water and sanitation services project in Port Harcourt claimed to be planning to reach 1.5 million people in Port Harcourt with improved WASH services. Yet, no waterfront communities or informal settlements were included in the initial designs. Data gathered by the Chicoco Maps team demonstrated the impossibility of reaching that many people unless the informal spaces of the city were included. In response, the project design was revised to include the city's waterfront settlements. Subsequently, as part of this larger project, in 2017, the mapping team led the data collection component of the World Bank-funded study "Technical Assistance to Fecal Sludge Management (FSM) Services in Port Harcourt, Nigeria."

While the data collection of this FSM study covered a range of urban morphologies, socio-economic conditions, and geographic locations, the project included a focus on low-income communities in Port Harcourt, and therefore a significant focus on waterfront communities. While the attention was primarily on documenting sanitation conditions and service provision, a number of climate-change-related risks and coping mechanisms were documented throughout the data collection process.

Both quantitative and qualitative research methods were employed to explore FSM practices along the entire service chain of collection, transport, treatment, and safe end use or disposal (World Bank 2017a). One of the data collection instruments used was a transect walk, during which enumerators walked through a community with several local residents to identify risks to public health, particularly with regard to the presence of fecal material and solid waste, and the proximity of these wastes to drainage channels and water resources. The World Bank defined objective was to observe environmental and public health risks along specified routes throughout the community.

The tool was revised by the community mapping team to fit the local context with revised survey questions and local terminology and piloted in two waterfront communities. The transect walk process was designed so that information on



**Fig. 5** A flash flood in Port Harcourt Old Town during rainy season (photo credit CMAP 2016). (Permission obtained)

community characteristics, observed risks, and an estimate of how frequently these risks occur could be documented for each route and supplemented with GPS points and photo documentation. Observed risks were scored on a scale of “1 to 5,” with a score of “5” denoting a particularly high risk.

Moreover, transect walks were helpful in: identifying and explaining the cause and effect of relationships among water uses, wastewater treatment, and sanitation conditions; identifying major problems and possibilities perceived by community members in relation to features or areas along the transect; providing an understanding of local technology and practices; and helping to triangulate and/or validate data collected through other tools.

Of the mix of 15 low-income informal settlements, middle-income neighborhoods, and high-income gated communities documented through transect walks, 73% experienced persistent flooding as a result of heavy rainfall and/or high tide (World Bank 2017a) (Fig. 5).

Furthermore, high risks were found to be more prevalent in low-income communities than middle- or high-income communities. Observed risks in these areas included unofficial dumpsites containing both solid and fecal wastes, pit latrines emptying into open drains, and evidence of open defecation. Low-income communities received a “high risk” rating of “4” or “5” for 75.8% of the observed conditions. In comparison, middle- and high-income communities received a high-risk rating for only 17.3% of the observed conditions (World Bank 2017a) (Figs. 6 and 7).



**Fig. 6** The Chicoco mapping team conducting transect walks with community members to observe and record sanitation conditions in Tonipriama Ama Waterfront (photo credit CMAP 2017). (Permission obtained)



**Fig. 7** The Chicoco mapping team conducting transect walks with community members to observe and record sanitation conditions in Baptist Waterfront (photo credit CMAP 2017). (Permission obtained)

The community team also received significant training on facilitating focus group discussions and developed a comprehensive questionnaire to gather qualitative data to compliment, validate, and/or challenge responses reported in the household survey. Information obtained from these discussions provided insight into household and community practices, service levels, and perceptions of past efforts to improve FSM services.

A focus group discussion was conducted at all 15 transect walk sites. Some focus group discussions were gender-specific. This was done because in mixed-gender sessions, men frequently dominated the discussions. Some men-only sessions were also held. Findings from these community focus group discussions stressed flooding challenges in the communities and informal methods being used to cope. Respondents in several communities mentioned that they themselves or others in the community were using nets or palm fronds to try to keep the solid waste and other debris that comes with floodwaters out of their homes. In three of the waterfront communities, it was mentioned that the community constructed a barrier, in some cases a metal plate or berm made of solid waste, along the riverbank to prevent flooding from seasonal high tides (seen below in Fig. 8) (World Bank 2017a).

Through the discussions, it was further revealed that flooding issues in waterfront communities were from the river and its high tide, as well as from drainage issues from upland areas and in the community. One respondent emphasized that, during rainy season, nets and barriers are removed to allow for waste to flow into the river (seen below in Fig. 9). A number of people also mentioned it was common practice in their community for people to use sticks or brooms to push the stagnant water and waste back out to the river after a rainfall (Fig. 9).



**Fig. 8** A solid waste berm being created along the waterfront in Afikpo waterfront community (photo credit CMAP 2017)



**Fig. 9** Nets installed in Baptist waterfront community to protect from waste flowing back into the community (photo credit CMAP 2017)



These focus group responses on flooding and their associated sanitation risks are supported by the findings of the Shit/Excreta Flow Diagram (SFD) created for this FSM project, which highlighted that other than the 13% of fecal sludge that remains unemptied in soak pits, there is no existing treatment of fecal sludge in low income areas of Port Harcourt, and it is directly entering the environment (World Bank 2017b).

## Data and Media Advocacy

One of the unique aspects of the Chicoco Collective is that it brings together mapping and data collection with a range of advocacy platforms. The community mapping team has worked to analyze their data and has developed presentations to help the community and broader stakeholders think about how to best use the information to improve their community. In Ibiapu Polo, for example, the team was able to tally up all of the daily household expenses on drinking water into a yearly cost for the community. This totaled over 18 million Naira (approximately USD 50,000). Working with the community leadership, the cohort developed a proposal that is now being used by the community. The proposal seeks support to bring together these resources at a community level to implement a solar-powered public borehole, which is estimated to cost around seven million Naira, to serve the entire neighborhood's potable water needs.

A group of community mappers and journalists have built pilot air quality monitoring devices to document air quality conditions throughout the city. While their homemade devices do not yet yield data of sufficient accuracy or compositional detail to support rigorous analysis, their data does evidence alarming air conditions and reveals telling temporal and spatial pollution patterns. A team of campaigning

citizen scientists has been working on how to use the data to create community awareness of air quality issues and is developing a citywide campaign. They have been able to further support this work through audiovisual documentation of illegal oil refining activities and their impacts on air quality, as well as interviews with community members and government representatives, including the then Rivers State Commissioner for environment.

These themes have also come together powerfully in other cultural and communicational forms, including as issues addressed through an original radio drama series “Angala Community,” set in a fictional waterfront community. The most recent season of the radio drama, which will be aired citywide on partner stations, is focused on the gendered dynamics of waterfront communities, with an emphasis on sanitation and environmental conditions, including air quality. Numerous radio programs have been written, recorded, and produced by the community mapping and media teams addressing environmental issues in waterfront communities. One program in particular investigated the causes of flooding in the community, exploring the consistent blockage of drains and creeks with solid waste and the construction of unapproved buildings on waterways. This is an issue worsening rapidly as the waterfronts densify and expand into the mangroves, further compromising the capacity of these ecosystems to maintain hydrological balance, further undermining local livelihoods, and exacerbating entrenched economic and environmental inequalities.

The Chicoco Collective deploys a range of creative research, outreach, and engagement methods to bring climate-change-related issues to the forefront of community concern and broader popular conversation. Chicoco Cinema has used an inflatable pop-up movie theatre to raise awareness and keep local communities in the picture, increasing the accessibility of the discourse. The Chicoco Band, which includes a number of mappers, is currently working on their own cover of the well-known Nigerian artist, Fela Kuti’s, “Water No Get Enemy” to address the current and looming issues of access to potable water in their waterfront communities and the country. Music can be a powerful medium of movement-building and a critical way of translating research findings into adaptation action.

The Chicoco team has established a program for prioritizing focal areas for their work each year. Focal issues have included housing, gender dynamics, and most recently, climate change. These issues are discussed through weekly sessions: “Bringing It Home: local impacts of global issues.” These sessions focus on cohort-led research and discussion to understand the global context of the issues and how they can be contextualized in Nigeria and in their communities. CMAP has supported these research efforts by connecting participants with area specialists and staging expert-led workshops and trainings. Climate change has been a sustained focus of CMAP’s engagement and capacity-building programs since 2017.

---

## Climate Change in Nigeria

Climate change is a global problem, but the effects vary from place to place, based on different climate change threats. According to the IPCC Fifth Assessment Report (AR5), the extent of climate change effects on individual regions will vary over time

based on different socio-economic and ecological systems for mitigation and adaptation (2014a). The same assessment stated that Africa is one of the most vulnerable continents to climate change (2014a). This vulnerability of Africa to climate change is driven by several factors of which weak/poor adaptation capacity is one (Ofoegbu and Chirwa 2019). Other studies revealed that the vulnerability of Africa can also be attributed to inadequate access to climate data, institutions, finance resources, and poverty (Ojomo et al. 2015).

Nigeria signed the 2015 Paris Agreement on September 22, 2016 and ratified it on May 6, 2017. Nigeria subsequently developed its nationally determined contributions (NDCs) and submitted it in May 2017. The NDC includes a section on adaptation but focuses primarily on mitigation actions. Nigeria has not submitted a National Adaptation Plan to the UNFCCC; however, it does have a National Adaptation Strategy and Plan for Action which was developed in 2011. This strategy suggests that large urban areas, including Port Harcourt, should develop and implement their own climate change adaptation plans. However, one has not yet been developed for the city.

In order to meet the required implementation of the stipulated provisions under the climate conventions, the department of climate change unit in the Federal Ministry of Environment was created to handle national climate initiatives (Nigerian Conservation Foundation 2008).

In 2003, upon realizing the need to produce observable information on climate change, the Nigerian Meteorological Agency (NIMET) was created, with a department for the development and delivery of climate information.

The majority of analysis on the potential impacts of climate change has been done at the national level. However, in some cases there is evidence of specific impacts in Port Harcourt, Rivers State, and/or the Niger Delta.

Increase in temperature is cited by several sources, with projections that Nigeria may experience as much as 2.5–4.5 °C by 2100 (Akande et al. 2017; Odjugo 2010; FME 2014). Variability in rainfall and the potential for the number of rainy days to decrease throughout the country and around 14% in the Niger-Delta coastal areas has been observed (BNRCC 2011; Odjugo 2005). While the number of rainy days may be decreasing, the frequency and magnitude of wind and rainstorms is increasing (Odjugo 2009).

The rise in sea level and flooding, especially in coastal regions like the Niger Delta, is another major concern (Matemilola 2019; Akande et al. 2017; Duru and Emetumah 2016, 2; Ebele and Emodi 2016, 7; FME 2014, 31; Odemerho 2014). This also impacts agriculture and provision of water due to salt-water intrusion (Odjugo 2010).

Frequent droughts, as the result of climate change, although mostly in the northern part of Nigeria, also have a negative impact on agricultural production and water security (Dioha and Emodi 2018; Elisha et al. 2017; Amanchukwu et al. 2015). Given some of the supply chain connections between Port Harcourt and the north of Nigeria, the impacts may still be felt by residents in Port Harcourt even if the impacts are not projected to take place in the Delta region.

There is some evidence that excessive heat, water stress, and air pollution will have an impact on health in Nigeria, especially in terms of water-related diseases

(diarrhea, cholera, and skin diseases), respiratory diseases, exhaustion, skin cancer, and cataract according to one source (Odjugo 2010). Another study found that the four diseases most likely to be exacerbated by climate change in Nigeria are cholera, meningitis, malaria, and pneumonia (Omoruyi and Kunle 2012). A WHO report on climate change and health noted in the country profile on Nigeria that its “peculiarity as one of the leading exporter[s] of oil in Africa, faces [it with] the challenge of balancing global energy demands with the need to address climate and environmental considerations” (WHO 2015).

In Nigeria, the Federal Ministry of Environment defines vulnerability as the element of sensitivity to climate change that relates to how ready a specific system is to respond to changes in the climate, whereas exposure refers to the extent of climate stress to which a particular unit or system is exposed or the presence of people, livelihoods, species, environmental functions, services and resources, infrastructure, or economic, social or cultural assets in places and settings that could be adversely affected (FME 2014).

In an assessment of African cities’ capacity to adapt to climate change, Nigeria as a country was ranked 157 out of 192 countries for overall vulnerability based on exposure, sensitivity, ability to adapt, human habitat, and governance readiness (Leal Filho et al. 2018). The ND-GAIN index ranked Nigeria slightly higher, at 127 for vulnerability, but the ranking fell to 148 due to low readiness.

The adaptation gap is the difference between the level of adaptation action in progress and the anticipated needs given the projected climate change impacts. The African Adaptation Initiative’s discussion paper from 2018, *Enhancing Action on Adaptation in Africa*, found that Nigeria is one of the countries with the highest gaps, over 90%.

An analysis by IIED (Satterthwaite et al. 2018) for the 2018 Cities and Climate Change Science Conference assessed likely impacts of climate change specifically on urban populations living in informal settlements and working in the informal economy. This covers a range of climate change impacts that are observed for Nigeria and therefore is relevant to the waterfront communities of Port Harcourt. With higher maximum temperatures, the report notes that the high density, lack of open space, poor ventilation, and corrugated roofs of many informal settlements could contribute to even higher indoor temperatures in these communities. Many informal settlements are in areas at high risk of flooding. These risks are increased by projected intensifications of precipitation. Low-lying waterfront communities in Port Harcourt are clearly particularly vulnerable, and poor quality housing and lack of insurance exacerbate the impact in such communities.

The main outcome of that conference was the Global Research and Action Agenda on Cities and Climate Change Science which highlighted informality as one of six key research gaps as well as the importance of coproducing this knowledge to fill these gaps (World Climate Research Programme 2019). This chapter aims to contribute to the knowledge gap of informality and climate change action as well as the recommendation for the co-production of knowledge as the methodology of the paper, cowritten by community members of the Chicoco Collective with international experts and based on local data collection and global sources reflects this approach.

## Climate Change Adaptation: Voices from the Community and Global Recommendations

### Global Recommendations for Advancing Adaptation

Adaptation, especially in cities and developing countries, has increasingly become a focus of international organizations and academia, which has resulted in the production of recommendations, guidelines, and priority areas for action.

The recent report *Adapt Now: A Global Call for Leadership on Climate Resilience* from the Global Commission on Adaptation states that a revolution is needed in three areas to advance adaptation action: understanding, planning, and finance. As part of the revolution on understanding, a better understanding of risks, solutions, and increased knowledge is cited.

In the report's chapter on cities, the main recommendations for the way forward are (1) mainstream information on climate risks in the planning and delivery of urban services, while strengthening local capacity; (2) harness the power of nature to respond to both water and heat risks; (3) build climate resilience by upgrading living conditions in vulnerable communities and informal settlements, drawing on community knowledge; and (4) increase climate-resilient investments and capture value from adaptation benefits (GCA 2019).

An in-depth analysis of several cities around the world and their adaptive capacity determined that cities should focus on the following: the need to prioritize actions, the importance of proper planning, the need for an integrated approach that takes into account structural and development issues, and emphasis on the poorer and more vulnerable communities (Leal Filho et al. 2019).

There has also been an increasing recognition internationally of the need to focus specifically on small and medium-sized cities; however, in a study of European cities, it was found that larger and more prosperous cities are the ones engaged in climate planning, whereas vulnerable cities are less engaged (Reckien et al. 2015). Although the study focused on Europe, the situation in Africa is likely the same and perhaps more so, however data and analysis on this is scarce.

There is not only a discrepancy between types of cities but also on the inequalities within cities and how this affects adaptation. The World Resources Institute (WRI) (2018) highlighted that “[c]ities around the world can thrive when they invest in climate-resilient infrastructure, information management system and risk-reduction programs. But, most often residents who live in risk-prone areas are often left out of the planning and implementation process, leaving them even more vulnerable.”

This report highlights that reducing vulnerability is not only about reducing exposure to hazards but also includes a socio-political aspect. Findings from the Urban Community Resilience Assessment program highlight the importance of social cohesion to increase individual and community resilience. This is one reason why relocation can be so damaging to resilience levels. Poor access to information communication systems for early warning and awareness of risks has also been shown to lower resilience (WRI 2018).

Given the importance of public awareness, a report by BNRCC (2011) revealed that the level of public awareness on issues related to climate change in Nigeria is considered to be low. Inadequate information is considered to be one of the key constraints encountered in adapting to climate change in Africa (Otitoju and Enete 2016). Anabaraonye et al. (2019) recommend that information and knowledge about climate change, its causes, and its impacts, as well as mitigation and adaptation strategies, should be made available in simplified, more accessible, forms and translated into local languages. Other technological tools and platforms, such as mobile phone applications and social media, should be utilized in improving information literacy, access to information, and awareness creation (Ayanlade et al. 2017; Duru and Emetumah 2016).

These reports and recommendations suggest some key areas of action that a city like Port Harcourt and organizations like CMAP and the Chicoco Collective could focus on to initiate and strengthen climate change mitigation and adaptation measures, principally: (1) increase understanding about climate change through both the collection and dissemination of locally relevant data and information; (2) carry out long-term and integrated planning; (3) build the local capacity of diverse stakeholders; and (4) prioritize vulnerable communities living in waterfront communities.

Unfortunately, despite the risks and vulnerabilities and the clear need for adaptation measures in Nigeria broadly and Port Harcourt specifically, actions to date have been limited. The reality on the ground presents many challenges to effective action. However, building on the overview of CMAP's work above, the next two sections will further explore the perspectives of local communities and then summarize how the work of CMAP, Chicoco Collective, and local communities can provide a basis for effective action.

## Port Harcourt in Focus: Climate Change Adaptation Awareness and Action

The Chicoco Collective devised and conducted a focus group research program to establish a baseline understanding of local perceptions of climate change impacts and adaptation approaches undertaken at the household and community level.

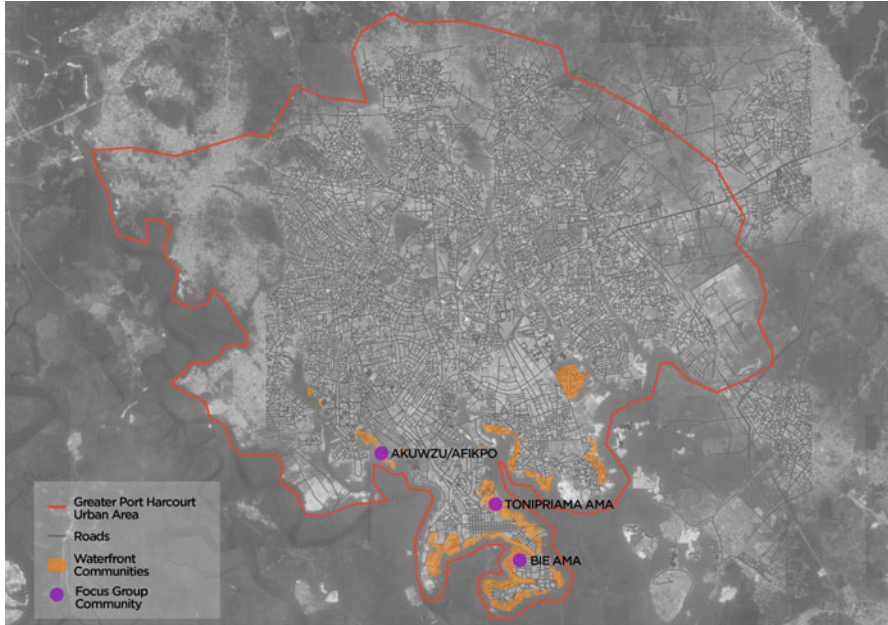
The sessions offered rich insights into local knowledge of climate change, and the various adaptation methods already adopted by informal waterfront communities. The following focus group questionnaire was created to guide the discussion.

Topic	Primary question	Secondary question	Tertiary question	Other question
Climate change awareness	Have you heard about climate change?	What have you heard about		

(continued)

Topic	Primary question	Secondary question	Tertiary question	Other question
		climate change?		
	What do you know about the impacts of climate change?			
Effects of climate change	Have there been changes in your community or city that you can attribute to climate change?	If yes, what are the impacts?	If no, have you experienced extreme heat or cold, flooding, changes in rainfall, more extreme storms, etc.?	
Adaptation	Are you or your household doing anything to adapt to the impacts of climate change? If yes, please explain. If no, why not?	What about your community?	Is the government doing anything?	
Solutions	Can you think of any solutions to adapt to the impacts of climate change?	At the household scale?	Community scale?	Government scale?

The focus group sessions were staged in three different parts of the city. Another session was held for members of the various Chicoco programs. The Chicoco cohort is drawn from waterfront communities across the city. Five men and five women of the Chicoco cohort were randomly selected to participate in that session. Focus group sites were selected to achieve a cross section of neighborhood types and to capture a holistic range of experience across age, socio-economic status, ethnicity, and location. Two communities were chosen from the Old Port Harcourt Township, one of the older colonial areas of the city, which is ringed by over half of, and some of the oldest, waterfront communities in the city. One community was selected from the Diobu axis of Port Harcourt, which is home to over 20 waterfront communities. These communities were selected based on their diverse situations, but also due to existing knowledge of and relationships with community leadership, which facilitated access. Importantly, each of the communities is also host to some aspect of the informal oil and gas industry. The discussions were held in a community space, either a town hall or central area in each community, and participants were recruited



**Fig. 10** Map of the greater Port Harcourt highlighting waterfront communities and selected focus group community locations (created by CMAP in March 2020 using QGIS and data from Rivers State Office of the Surveyor General)

with the help of community leadership to include a mix of men and women. A map of Port Harcourt highlighting the focus-group communities can be seen below (Fig. 10).

Akwuzu/Afikpo is a low-income waterfront community in the Diobu area established over 40 years ago. Entrance to the community is through a community market at the top of a steep laterite slope. The community is only accessible by pedestrians on poorly maintained concrete steps. The community has had minimal government-led interventions and minimal community provision of drainage systems, security, schools, and toilet facilities or potable drinking water. Along with other waterfront communities in the Diobu axis, in 2009, Akwuzu/Afikpo was faced with the threat of demolition. Many residents of the community are actively involved in the fishing industry. The community is also a major hub for oil bunkering activities, also known as kpo-fire. The area is predominantly occupied by Kalabari people.

Ten people, five men and five women, attended the focus group session in Akwuzu/Afikpo: the community chief, four fishermen/women, two higher institution students, a retired nurse, and two traders.

Bie Ama Community is a mixed middle- and low-income community in the Old Port Harcourt Township located on a reclaimed wetland area. Bie Ama is made up of five smaller communities or “polos” and is predominantly occupied by Okrikan people. Bie Ama is popularly known as New Road in Borokiri and was established



on a sand-fill project in the early 1980s. This community has over 800 structures and has been developed with some regard to a layout plan. It is comprised primarily of cement block structures with aluminum, asbestos, and zinc roofing materials. The community has several churches and a mix of private nursery, primary and secondary schools. Residents include civil servants, teachers, artisans, traders, and contractors. As a waterfront community, the trading of illegally refined or bunkered products is prevalent.

Ten people, seven men and three women, participated in the focus group: two medical doctors, the community youth leader, two bunkerers (workers in the informal oil sector), a retired Nigerian national petroleum company worker, the former Radio Rivers/Nigerian Tide managing director, the female community leader, and two traders.

Tonipriama Ama is the host community of the Chicoco Collective. This waterfront community is comprised of seven smaller communities or “polos.” It is predominately occupied by Okrikan people and has existed for over 60 years. This community has over 2,000 structures, constructed from a mix of concrete block and less durable materials such as zinc or wood. The community has a busy commercial dock that is a hub for ferries, fishermen, and oil bunkering boats. There are also several marine companies located in the community. The community has had several government interventions, including the paving of several access roads and the construction of a private government jetty. There are two roads running through the community, and it is easily accessible by motor vehicle. There is one major community public toilet facility and several public boreholes.

The Tonipriama session also comprised ten participants, four women and six men: the Ama (the collective administrative unit containing the polos) chairman, four traders, a teacher, two fishermen, a bunkerer, and a student.

In the focus groups, participants were first asked if they had heard of climate change and what they understood by the term and of the phenomenon. Responses evidenced a general familiarity with the term and an understanding that climate change is related to changing weather conditions and caused by humans. Despite some familiarity with the term climate change, it was evident that many respondents used the phrase to describe any environmental issue, without a clear understanding of the differentiation between degradation (air quality issues, water pollution, etc.) and changes in climate (changes in precipitation, flooding, increased temperature, etc.).

## **Climate Change Impacts Observed**

All of the communities shared experiences that they attributed to climate change and the sense that its impacts are felt citywide, increasing in intensity and frequency. Heat and flooding (both from sea level rise and excessive rainfall) were raised across groups as an observable impact of climate change, popular perceptions aligning with current scientific research on impacts of climate change in Nigeria.

Food insecurity and hunger, as a result of food scarcity, increased food prices, difficulty of farmers to predict the weather for planting seasons, scarcity of seafood due to decrease in catch or the catching of dead fish, and food storage and spoilage issues were raised by all groups. More research is needed to ascertain what links, if any, these issues have to climate change. However, these are clearly primary concerns for communities and should be addressed in adaptation and/or development research and action.

Health issues were also raised by all groups: Disease burden increase, with measles and chicken pox cited specifically, rashes, dehydration, respiratory issues, cancer, and eye conditions were all perceived by participants as being linked to climate change. While such attribution is far from clear for all the conditions mentioned, connections to air pollution seem to be a reasonable assumption, and it is likely that the dehydration and rash conditions are related to heat and/or water quality and access. More research would be needed to confirm such links. Nevertheless, it is clear that here too, adaptation and development measures would need to address community-identified health priorities.

The issues of pollution and environmental degradation were another focus of all groups. The black soot crisis has gained citywide attention recently, and this was reflected in the group discussions. The toxicity of rainwater, rendering it unusable for consumption or cooking, was mentioned by many. Marine habitat pollution and its impact on fish stocks were another commonly voiced concern for waterfront communities with members who still depend directly on aquatic urban ecosystems for their livelihoods. Again, while air and water quality may be linked to climate change-driven dynamics, not all of these issues are necessarily directly attributable to climate change. Nevertheless, it is likely that climate change exacerbates these problems. It is clear that environmental degradation is a major concern and in Port Harcourt the drivers of climate change are the same causes of environmental degradation. Therefore both mitigation and adaptation efforts should address these environmental issues.

Other issues raised in different groups, relating to migration, cost of living increases, and security, may involve interesting direct or indirect relationships to climate change. For instance, migration is a much researched topic in this connection, but more area-specific data would need to be gathered to determine causality and appropriate adaptation actions.

## **Adaptation Actions**

As the effects of the climate crisis intensify, residents of Port Harcourt have developed different coping techniques for them. The participants of the focus group highlighted some of the ways they or their neighbors are changing their behavior. For increased heat and rising temperatures, coping techniques included: bathing with cold water three to four times a day, showering multiple times at night, and sleeping outside till late in the night to get some cooler air before going indoors and then sleeping on relatively cool mud or stone floors.

Increases in water intake to mitigate dehydration caused by the heat have significant financial impacts on households that spend disproportionately high proportions of their income on food and water essentials. Participants reported that water is also used to keep food cool and to slow its spoiling in the absence of reliable power for refrigeration. Other practices of drying food with salt were also emphasized as a way to preserve their food and kill pests, such as worms. Additionally, as a result of increased food prices, some respondents say that they are eating only once a day. Self-rationing is increasingly common.

Adaptation methods to address flooding include improving waste management by methods such as establishing more designated dumping sites to discourage people from throwing waste in waterways. Other discussed methods included community gutter cleaning efforts, construction of high tables to store personal belongings, blocks to raise beds, and raised doorsteps to prevent water ingress.

Respondents discussed their discomfort with and concern for the black soot air quality crisis facing their city. Concern for their health has prompted some to start wearing facemasks on days when air quality was visibly bad. The wearing of facemasks was practiced before the recent coronavirus pandemic.

Despite being asked about their adaptive practices, several of the responses were not necessarily relevant as adaptation measures, but really more about other impacts related to a changing climate, particularly increasing temperatures. Many focus group participants brought up the issue of increased lethargy and unproductivity at work from the higher temperatures. Others mentioned the need to increase their use of generators, which although not explicitly said, is likely related to needing to run fans.

It is clear that most adaptation efforts are at an individual level or household level. Knowledge of adaptive practices at community or broader scale was quite limited. But, as noted in the findings from the fecal sludge management study, some communities are undertaking collective adaptation actions, such as managing flooding issues in a coordinated manner with berms and nets. It is unclear as to whether focus group participants are simply unaware of any actions that their community or the government may be undertaking or whether they are not able to relate any actions specifically to a response to a changing climate. This highlights the need for more awareness raising of potential adaptation actions as well as planning for more coordinated efforts.

One of the communities is making efforts to curb issues of poor sanitation and dumping by discouraging the act of disposing waste in waterways by fining offenders. Two of the communities have active community leadership committees and subcommittees in charge of sanitation, and community electricity and light, among other specialized issues. These committees are tasked with maintaining community infrastructure and solving challenges that arise in the community by enacting rules and regulations, sometimes including fines or punishments for breaking these rules, or introducing levies to construct new infrastructure. Tonipriama Ama, for example, has been charging for use of and maintaining a public toilet, and likewise through its light committee, has organized levies to replace light poles and broken transformers. Although currently these committees have not addressed impacts directly related to a changing climate, these initiatives demonstrate a capacity to develop and deploy adaptations at community level.

---

## Proposed Adaptation Solutions

When asked about other potential solutions for addressing climate change, the participants highlighted the need for education, behavior change, infrastructure projects, and government intervention. They proposed that, to tackle the effect of the climate crisis, government and relevant stakeholders needed to be more responsive, accountable, and active. They criticized lack of action, insufficient resourcing, and lack of human and technical capacity. Government and relevant stakeholders were urged to lead sensitization efforts and to provide basic amenities. There was a clear understanding of interplay between behavior and infrastructure. For example, on the one hand, the need for changed waste dumping practices, particularly regarding waterways, and for waste disposal practices that facilitate recycling and reuse was recognized. On the other hand, groups also stressed the need for better waste management systems including the placement of proper disposal containers within the communities and the construction of better gutters and drainage systems.

Groups proposed awareness-through-action and learning-by-doing approaches, as well as the need for more active community debate. Tree planting and community town hall programs were mentioned in this connection. Community sanitation exercises – the mobilization of the entire community to clean streets, drains, and public spaces – were also mentioned. Indeed, this capacity to mobilize, *en masse*, as a community is one of the significant resources that such settlements can draw on.

Energy was a perennial topic of debate. Gas flaring has long been a highly visible example of the violent environmental externalizations of the hydrocarbon economy in the Niger Delta. People linked the demand to end flaring with the desire to transition to renewable energy. Respondents wanted to see oil and gas companies halt polluting activities and proposed “trapping” carbon emissions. The technical approaches to doing so were not detailed. Security forces tasked with policing the informal oil industry often spill confiscated hydrocarbon products directly into waterways or set them ablaze. Respondents voiced strong opposition to these practices and proposed that, instead, confiscated product should be taken to official refineries. The retraining of bunkerers and the regulation of the informal economy to improve the environmental standards of operations were also proposed. While these are not strictly adaptation efforts, they can be considered as modest mitigation efforts and community actions aimed at a cleaner community environment.

---

## Conclusions and Recommendations

Port Harcourt and many other cities in Africa face a multitude of climate change, environment and development challenges. These challenges are greatest in informal settlements. As informality is the dominant mode of African urbanism, it is critical that interventions respond to the situated constraints and potentials of informality and how it is variously manifested in communities and neighborhoods across the continent. To date, climate change adaptation has not necessarily been a priority in and for informal urban settlements. Many of the requirements for effective action –

from data to finance – are often lacking. Too often, the priorities, knowledge, skills, and participation of local residents themselves are missing from external interventions. However there is growing awareness of the problems and initial steps and information that can be built upon for effective solutions. Below are recommendations drawn from the experience of CMAP, Chicoco, and the waterfront communities in Port Harcourt. As the formulation of these recommendations has been led by residents and through partnership with international experts, we hope they might serve as a basis for mobilization and action in other African cities facing similar constraints and opportunities.

- *Awareness and local knowledge.* There is a lot of consistency between scientific findings on the impacts of climate change in Nigeria and those observed and recorded in local focus groups. This suggests that, while innovation is needed in the popular dissemination of research findings, many residents in informal settlements may not be aware of the latest research on climate change, they are acutely aware of direct impacts from their own lived experience and are developing local adaptations. This experience, critical awareness, and approach to situated adaptation are a potentially valuable asset for climate change response efforts.
- *Building awareness through local methods.* International organizations and governments should draw on locally established information sharing and storytelling initiatives and networks. Chicoco Radio and Chicoco Maps' Encounter and Exchange program are examples of the potential of community media and action programs not only to raise awareness and strengthen networks locally, but also to catalyze citywide dialogue. The roadshows, concerts, town hall listening clubs, broadcasts, and live discussion programs that were part of Chicoco's first radio drama season successfully stimulated citywide debate around issues of forced evictions and police brutality. Such a platform could easily be mobilized for climate change adaptation and environmental justice issues.
- *Inclusive data and knowledge collection and sharing.* There is a need for more institutional investment in knowledge and data gathering efforts on climate change impacts in Nigeria at the national and local levels. To collect and disseminate knowledge and data relevant to informal urban settlements in Nigeria, residents of those settlements need to be successfully involved. The deep, detailed, accurate, and appropriate datasets gathered by the young Chicoco Maps team with CMAP's support demonstrate a successful methodological approach to, and effective methods of, participatory data gathering and sharing in Nigeria's informal settlements. This participatory, partnership-based approach can be mobilized in a more focused way on climate change research and the development of sustainable local adaptations.
- *Integrated solutions and local context.* Adaptation solutions need to tackle development and environmental justice issues alongside climate change adaptation action, especially health issues. It is also important to recognize the context of the local economy – both formal and informal. In the case of Port Harcourt, this includes reckoning with the economic domination of the oil and gas industry.

- *Small and local efforts can be compounded for larger impact.* Some routes to scale involve a concert of small-scale interventions. CMAP and Chicoco Maps' citywide sanitation research found that the solution to Port Harcourt's sanitation crisis is not a billion-dollar central sewerage system. Rather, onsite community solutions, manageable at neighborhood-level and network-scalable, offer a sustainable approach through which many small actors can coordinate to achieve scale. As found in the focus groups, individuals and households will take adaptive measures that can be effective for reducing loss and vulnerability.
- *Large-scale responses are also necessary, with community involvement and input.* Local communities have devised some effective individual or neighborhood-level adaptation techniques, but larger infrastructure interventions, requiring access to significant capital and technologies, are necessary. Yet, for these solutions to achieve sustainability, they nonetheless need to engage and involve community actors. In a city like Port Harcourt, where the government suffers a deep trust deficit, large-scale interventions often fail because of a lack of local cooperation or even active resistance. The trust and involvement of community actors is crucial to large-scale climate change responses, particularly as large-scale behavior changes and cultural shifts are necessary for success.
- *Bottom-up collaboration to build accountability.* A bottom-up approach follows from the previous recommendation. While community members have raised the need for government intervention and effective government service provision, heavily top-down approaches to external interventions in communities with already strained relationships with their representatives are going to be difficult. Involving communities, not merely in consultation exercises, but actively in project design, is key. This is likely both to increase the appropriateness of adaptation measures, and importantly, to build a robust demand for duty bearer accountability. Demand-side platforms for accountability for climate change action in cities like Port Harcourt are critical to counter a culture of flourishing impunity that has allowed staggering environmental degradation and unsustainable exploitation to go unchecked for decades.

**Acknowledgments** In-kind financial support was provided by the Chicoco mapping team for research, data collection and analysis, and the focus group discussion support team, namely the recording technician, George Sosipiriala, and community engagement specialist, Fubara Tokuibiyeh Samuel. Michael Uwemedimo, Ana Bonaldo, and the rest of the CMAP team also provided in-kind support and guidance for this chapter.

---

## References

- African Adaptation Initiative (2018) Enhancing action on adaptation in Africa. Discussion paper for Africa state of adaptation report
- Akande A, Costa AC, Mateu J, Henriques R (2017) Geospatial analysis of extreme weather events in Nigeria (1985–2015) using self-organizing maps. *Adv Meteorol* 2017(2):1–11
- Amanchukwu RN et al (2015) Climate change education in Nigeria: the role of curriculum review. *Education* 5(3):71–79

- Anabaraonye B et al (2019) Educating farmers and fishermen in rural areas in Nigeria on climate change mitigation and adaptation for global sustainability. *Int J Sci Eng Res* 10(4):1391–1398
- Ayanlade A et al (2017) Comparing smallholder farmers' perception of climate change with meteorological data: a case study from southwestern Nigeria. *Weather Climate Extremes* 15:24–33
- Bloch R, Monroy J, Fox S, Ojo A (2015) Urbanisation and urban expansion in Nigeria. Project report. ICF International, London
- BNRCC (Building Nigeria's Response to Climate Change) (2011) National adaptation strategy and plan of action on climate change for Nigeria (NASPA-CCN). Prepared for the Federal Ministry of Environment Special Climate Change Unit
- Collaborative Media Advocacy Platform (CMAP) (2018) Ibiapu Polo, Amatari Polo, and Darick Polo. Household Survey Data Summary Report
- Dioha MO, Emodi NV (2018) Energy-climate dilemma in Nigeria: options for the future. *IAEE Energy Forum* 2018(2):29–32
- Duru NP, Emetumah CF (2016) Evaluating the effects of information literacy on climate change awareness among students in Imo State University. *Arch Current Res Int* 4(3):1–10
- Ebele NE, Emodi NV (2016) Climate change and its impact in Nigerian economy. *J Sci Res Rep* 10(6):1–13
- Elisha I et al (2017) Evidence of climate change and adaptation strategies among grain farmers in Sokoto State, Nigeria. *IOSR J Environ Sci Toxicol Food Technol (IOSR-JESTFT)* 11(3):1–7
- Federal Ministry of Environment (FME) (2014) United Nations climate change Nigeria. National Communication (NC). NC 2. 2014
- Global Commission on Adaptation (2019) *Adapt now: a global call for leadership on climate resilience*, Washington, DC
- IPCC (2014a) Summary for policymakers. In: Field CB et al (eds) *Climate change 2014: impacts, adaptation, and vulnerability. Part A: global and sectoral aspects. Contribution of working group II to the fifth assessment report of the intergovernmental panel on climate change field*. Cambridge University Press, Cambridge/New York, pp 1–32
- Leal Filho W et al (2018) Strengthening climate change adaptation capacity in Africa-case studies from six major African cities and policy implications. *Environ Sci Pol* 86:29–37
- Leal Filho W, Balogun AL, Olayide OE et al (2019) Assessing the impacts of climate change in cities and their adaptive capacity: towards transformative approaches to climate change adaptation and poverty reduction in urban areas in a set of developing countries. *Sci Total Environ* 692:1175–1190
- Matemilola S (2019) Mainstreaming climate change into the EIA process in Nigeria: perspectives from projects in the Niger Delta region. *Climate* 7(2):29
- Nigerian Conservation Foundation (2008) Climate change. <http://www.ncfnigeria.org/component/content/article/90-programmes/127-Climate-Change>. Accessed Mar 2020
- Odemerho FO (2014) Building climate change resilience through bottom-up adaptation to flood risk in Warri, Nigeria. *Environ Urban* 27(1):139–160
- Odjugo PA (2005) An analysis of rainfall patterns in Nigeria. *Glob J Environ Sci* 4(2):139–145
- Odjugo PAAO (2009) Quantifying the cost of climate change impact in Nigeria: emphasis on wind and rainstorms. *J Hum Ecol* 28(2):93–101
- Odjugo O (2010) General overview of climate change impacts in Nigeria. *J Hum Ecol* 29(1):47–55
- OECD/SWAC (2020) Africapolis (database), [www.africapolis.org](http://www.africapolis.org). Accessed 11 Feb 2020
- Ofoegbu C, Chirwa PW (2019) Exploring the potential for green growth uptake in the South African forest sector. *Reg Environ Chang* 19(5):1469–1480
- Ojomo E, Elliot M, Amjad U, Bartram J (2015) Climate change preparedness: a knowledge and attitudes study in southern Nigeria. *Environment* 2(4):435–448
- Omoruyi EP, Kunle OA (2012) Effects of climate change on health risks in Nigeria. *Asian J Bus Manag Sci* 1(1):204–215
- Otitaju MA, Enete AA (2016) Climate change adaptation: uncovering constraints to the use of adaptation strategies among food crop farmers in South-west, Nigeria using principal component analysis (PCA). *Cogent Food Agric* 2(1):1–11

- Reckien D, Flacke J, Olazabal M, Heidrich O (2015) The influence of drivers and barriers on urban adaptation and mitigation plans—an empirical analysis of European cities. *PLoS One* 10(8):1–21
- Satterthwaite D, Archer D, Colenbrander S, Dodman D, Hardoy J, Patel S (2018) Responding to climate change in cities and in their informal settlements and economies. Consultant report presented at the IPCC international scientific conference on cities and climate change, Edmonton. International Institute for Environment and Development, London
- Theis M, Lloyd-Jones T, Adenekan S, Gusah S, Moor M, Mulyawan B, Gusah D (2009) Port Harcourt waterfront urban regeneration: scoping study. Project Report. MLC Press, Max Lock Centre, University of Westminster, London
- World Bank (2016) From oil to cities: Nigeria's next transformation. *Directions in development*. World Bank Group, Washington, DC
- World Bank (2017a) Sustainable WSS services in Nigeria (Vol. 2): Data collection report (English). World Bank Group, Washington, DC
- World Bank (2017b) Sustainable WSS services in Nigeria: fecal sludge management – a practical guide for evaluating needs and developing solutions (English). World Bank Group, Washington, DC
- World Climate Research Programme (2019) Global research and action agenda on cities and climate change science – full version. In: Prieur-Richard AH, Walsh B, Craig M, Melamed ML, Colbert M, Pathak M, Connors S, Bai X, Barau A, Bulkeley H, Cleugh H, Cohen M, Colenbrander S, Dodman D, Dhakal S, Dawson R, Espey J, Greenwalt J, Kurian P, Lee B, Leonardsen L, Masson-Delmotte V, Munshi D, Okem A, Delgado Ramos GC, Sanchez Rodriguez R, Roberts D, Rosenzweig C, Schultz S, Seto K, Solecki W, van Staden M, Ürge-Vorsatz D (eds) *WCRP Report No. 3/2019*, 31pp
- World Health Organization (2015) Climate change and health: country profile. United Nations Framework Convention on Climate Change, Nigeria
- World Resources Institute (2018) Prepared communities: implementing the Urban Community resilience assessment in vulnerable neighborhoods in three communities, Washington, DC

**Open Access** This chapter is licensed under the terms of the Creative Commons Attribution 4.0 International License (<http://creativecommons.org/licenses/by/4.0/>), which permits use, sharing, adaptation, distribution and reproduction in any medium or format, as long as you give appropriate credit to the original author(s) and the source, provide a link to the Creative Commons license and indicate if changes were made.

The images or other third party material in this chapter are included in the chapter's Creative Commons license, unless indicated otherwise in a credit line to the material. If material is not included in the chapter's Creative Commons license and your intended use is not permitted by statutory regulation or exceeds the permitted use, you will need to obtain permission directly from the copyright holder.





---

# Index

## A

- Above ground biomass
  - and carbon stocks, 2749
  - estimation of, 2737–2740
- Accra
  - climate change adaptation measures to flooding, 2397–2399
  - description, 2390–2393
  - flood control and adaptation measures, 2395
  - flooding impact on socio-economic livelihoods, 2394–2395
  - individual and community, 2396
  - limits and barriers to adaptation to flooding, 2399
  - metropolitan assembly/government, 2397–2398
  - vulnerability to perennial floods, 2389–2391
- Accumulated growth index, 621
- Adansi North District, 1510
- Adaptation, 5, 177, 214–222, 682, 1055, 1057, 1062, 1064, 1068, 1072, 1074, 1077, 1113, 1856, 1901, 2027, 2791
  - climate change, 364, 376
  - definition, 2100
  - to environmental change, 375
  - measures, 729
  - policy, 1769
  - of reservoir operations, 2376
  - techniques, 1586, 1597
  - tracking, 1557, 1576
- Adaptation strategy(ies), 237, 341, 474, 514, 870, 1847, 1939, 1949–1950, 2144–2147, 2149, 2150, 2156, 2162, 2165, 2595, 2602, 2606
  - climate change, 474, 483
  - UIVs farmers, 474
  - West Africa, 1549–1550
  - in Zimbabwe, 643–644
- Adaptive capacity, 1499, 2027, 2100, 2101, 2103, 2105, 2107, 2108, 2112, 2118, 2198
  - community, 51
  - by farmers, 54
  - host communities, 58
  - to mitigate climate variability impacts, 54
  - policy maker, 51
  - SSA challenges, 50
  - vulnerable communities, 52
- Adaptive capacity, Africa’s small-scale farmers
  - binary logistic regression model, 105–106
  - farmer perceived factors, 100–101
  - non-cause-effect relationship, 103–105
- Adaptive measures, 550
- Adaptive strategies, of farmers, 2171
- Addis Ababa’s urban planning, 866
- Administration of Water and Sanitation
  - Infrastructure (AIAS), 2633–2636, 2645, 2647, 2649
- Adoption, 516, 1857
- Aerobic composition, 1098
- Aerobiotics, 1112, 1115
- Aeroponic method, 80
- Aerosol monitoring, 2250–2252
- Aerosol optical depth (AOD), 1526, 1529
- Aerosol Radiation and Clouds in southern Africa (AEROCLO-SA) project, 2251
- Afforestation, 2307
- Africa
  - CIS in, 1249
  - climate sensitive sectors, 1248
  - regional scope on, 1250
  - smallholder farmers in, 1250

- Africa, climate change  
 animal and farmer resilience and adaptation, 1846–1848  
 animal physiology, 1839–1840  
 aquatic non-vector borne diseases, 1844–1845  
 climatic zones, 1837–1838  
 livestock production and health, 1838–1839  
 meteorological, vector and health data, 1845–1846  
 midge-borne diseases, 1842  
 mosquito-borne diseases, 1842  
 pathogen transmission ecology, 1840  
 terrestrial non-vector borne diseases, 1844  
 tick-borne diseases, 1843  
 tsetse fly-transmitted diseases, 1842–1843  
 vector ecology, 1840–1841  
 vulnerability of livestock production systems, 1839
- Africa Climate Smart Agriculture (ACSA), 227
- African Academy of Sciences (AAS), 1304
- African cities, 850–852, 854, 856, 857
- African countries  
 bioeconomy production determinants, 2525–2528  
 bioeconomy readiness, 2528  
 bioeconomy related activities, 2523
- African Easterly Jet (AEJ), 1129, 1130, 1132, 1145, 1153
- African Easterly Waves (AEW), 1129
- African yam bean  
 climate change resilience, 462–465  
 in-situ or ex-situ, 465  
 nomenclatural etymology, 459–464  
 nutritional potentials, 459–462  
 policy and conservation, 465  
 underutilized plant genetic resources, 458–461
- Africa's Infrastructure Diagnostic Report, 505
- Africa's small-scale farmers, climate change, 106–107  
 adaptive measures, 94–95  
 adverse effects, 91–92, 102  
 barriers to adaptation, 95–96  
 binary logistic regression model, 105–106  
 continuous independent variables, 103–104  
 effectiveness of, 96  
 farmer perceived factors, 100–101  
 non-cause-effect relationship, 107  
 perceptions, 90–91  
 qualitative independent variables, 104–105  
 vulnerability, 92–93
- Agenda 2030 Sustainable Development Goals, 784–785
- Aggregate energy consumption, 1426
- Agrarian communities, livelihoods of, 2170
- Agricultural bio-diversification, 2489
- Agricultural biodiversity, 748
- Agricultural Development Program (ADP), 2108
- Agricultural development project (ADP), 301
- Agricultural Extension Officers (AEOs), 217
- Agricultural production systems, CCAM conservation agriculture, 1454–1455  
 organic farming, 1455–1456  
 sustainable intensification, 1452–1454
- Agricultural, Technical and Extension services (AGRITEX) department, 2426
- Agricultural Training Centre (ATC), 773
- Agriculture, 586, 1109, 1111–1113, 1115, 1498, 1790, 2029, 2507  
 in Cameroon, 263  
 vulnerability, 318
- Agriculture, Forestry and Other Land Use (AFOLU), 876
- Agriculture sector, sub-Saharan Africa, 1010–1011
- Agriculture value chain (AVC), 1817–1818  
 dimensions of climate change impacts, 1818–1821  
 indigenous climate change adaptation strategies, 1822–1823
- Agri-preneurship, 2147
- Agro-ecological lower midlands zone IV and V in Kenya  
 climate change, 966–972  
 climate smart crop management, 970–972  
 climate variability, 972–978  
 evapotranspiration variations, 982–983  
 GIS and remote sensing in, 984–985  
 precipitation amount, rate and soil moisture variations, 978–981
- Agro-ecological zones, 475, 2171
- Agroecology, 1723  
 adoption and practising of, 373  
 and climate change, 375  
 experiences of, 364  
 implementation of, 368  
 smallholder farmer, 369  
 training on, 366  
 villages implementing, 371
- Agroforestry, 79, 842, 1450, 1796, 1797, 1827  
 practices, 94, 106
- Agro-pastoralism, 2119, 2593, 2597, 2605
- Agro-pastoralists, 1632, 1633, 1638
- Agro-pastoral Keita department, 2127–2131
- Aguleri community, 1713
- AirQo, 1118

- Akwuzu/Afikpo, 2794
- Algeria
- future climate projections, 1976–1980
  - future water needs, 1974
  - immediate water needs, 1974
  - impact of climate change on superficial and underground water resources, 1975–1976
  - location, 1970
  - palliative measurements, 1980–1981
  - population, 1972
  - seawater desalination, 1981
  - water consumption in agricultural sector, 1971
  - water potential and climate change, 1973–1974
- Algorithms, 1109, 1111, 1112, 1115, 1118–1120, 1122
- Allometric equations, 2737, 2739, 2744
- Ambient air temperature measurements, 1589
- Ammonium acetate method, 1474
- Analysis of variance
- carbon stocks, 2744
  - soil organic carbon, 2749
- Anglophone community(ies), 2179–2180
- Women and climate change adaptation, 2183–2184
- Animal health, 1838
- animal management adaptations, 1847–1848
  - community resilience and adaptation, 1846–1847
  - disease prevention practices, 1848
  - meteorological, vector and health data, 1845–1846
  - non-vector borne diseases, 1843–1845
  - vector-borne infections, 1841–1843
- Animal husbandry, 2507
- Anomaly correlation coefficient (ACC), 1623–1625
- ANOVA, 1669, 1672, 1674, 1675
- Anthropogenic activities, 89
- Anticipated Energy Penetration (AEP), 1280
- Anticipatory adaptation, 2410
- Anticipatory climate change adaptation coping strategies, 1025–1026
- Apollo Agriculture, 1112
- Application Programming Interfaces (APIs), 1253
- Aquaculture, 790, 791
- challenges, 803
- Aquatic non-vector borne diseases, 1844–1845
- Aquifer(s), 717, 729, 731, 2701–2702
- confined and unconfined, 814
  - in rural areas, 814
- Aquifer recharge management
- infiltration systems, 820–823
  - irrigation water, 823–824
  - storm-water runoff, 822–823
- Arable and plant cultivation methods, 1442–1444, 1447, 1451–1452
- Arable farmers, in Rwenzori region, Western Uganda
- climate change perceptions, 1694–1698
  - sample size, data collection and analysis, 1690–1691
  - socio-economic characteristics, 1691–1693
- Arduino stations with DHT sensor only, 1745
- Arid and semi-arid lands (ASALs), 780
- Arid rangelands, 1855
- Artificial intelligence, 1823
- Artificial intelligence (AI), in Africa, 1110, 1119
- academic and private sector, 1111
  - AirQo, 1118
  - data inadequacies, 1121–1122
  - ethical issues, climate change impacts, 1120–1121
  - farming, 1111
  - fintech, 1112
  - international organizations and global technology companies, 1116–1118
  - public-private partnerships, 1115–1116
  - R&D, 1110
  - UN agencies, 1114–1115
  - WIMEA-ICT, 1118–1119
- Arusha, 2597
- Assets, 168, 178
- financial, 169
  - and food production nexus, 172–174
  - household, 171
  - human, 169
  - natural, 169
  - physical, 169
  - social, 169
- Atmospheric CO<sub>2</sub> concentration, 2252
- Atmospheric radon concentration, 449
- Autonomous adaptation, 2345, 2348, 2353, 2410
- Pearson correlations of, 2349
  - strategies by surveyed households, 2351
- Autonomous climate change adaptation measures, 1024–1025
- Autonomous Sanitation Service, 2636

- Availability of legal, regulatory and administrative frameworks, 997, 998, 1000–1004
- Average peak sunshine, 912
- Average variance extracted (AVE), 1001
- Avoided emissions, 1388, 1391–1392, 1396
- Awareness  
and local knowledge, 2799  
through local methods, 2799
- B**
- Bacillus thuringiensis israelensis* (*Bti*), 2496
- Balanced incomplete block design (BIBD), 1633
- Bamenda I, Cameroon, 714  
adaptation measures, water supply, 728–731  
data collection, 719  
inter-annual rainfall variability and anomalies, 720  
location, 717–719  
monthly rainfall variability and anomalies, 721–722  
rainfall variability on water supply, 725–728  
rainy days and rainfall intensity, 722–723  
seasonality index, 724–725  
standardized precipitation index, 723–724
- Barriers to climate change adaptation, pastoralists  
credit facilities, 668, 670  
data collection methods and sample size, 663–664  
demand-driven extension service, 667  
high cost, 666, 669  
insecure land tenure/property rights, 668, 670  
labor shortages, 668, 670  
origins of barriers, 670–672  
pastoralists' land tenure and access to land, 666  
sources of barriers, 668–670
- Beach nourishment, 2683
- Behavior Change Communication, 2491
- Behavioral changes, 176
- Beira, 2331
- Benguela system, 2249
- Beni Haroun Development, 1981
- Benin, 2223
- Binary logistic regression, 1502, 1506  
model, 98, 105–106
- Bin El Ouidane  
dam reservoir of, 2365  
evaporation calculation, 2371  
geographical location map, 2365  
hydraulic complex of, 2365  
intra-annual evolution, 2375  
intra-annual evolution of evaporation, 2377  
typical Top-Down procedure, 2366
- Bio-char, 1097–1098, 1314  
applications, 1410  
ash content, 1323  
*Daniella oliviera* wood, 1412  
moisture content, 1321  
preparation, 1410  
proximate analysis, 1319  
remediation on the growth parameters of *T. occidentalis* c, 1413–1415  
remediation on the heavy metal concentration of *T. occidentalis*, 1414  
stability of, 1409  
tree species for production, 1318  
uses, 1408, 1409  
yield, 1317, 1321–1322
- Biocontrol agents (BCA), 748
- Biodigester, 1383–1390, 1392, 1395
- Biodiversity, 316, 1111, 1443, 1450, 1455, 1457, 1459, 1461
- Bioeconomy, 2520, 2523  
BRI, 2524–2525  
as climate action, 2521–2522  
definition, 2524  
forest-based, 2522  
production determinants, 2523–2528
- Bioeconomy readiness index (BRI), 2524–2525, 2529, 2530
- Bioenergy, 1092–1094, 1961
- Bio fertilizers, 69, 1471
- Biogas digesters, 1297, 1299, 1302
- Biogas production, 1383, 1390, 1391  
up-scaling, 1386–1387
- BioGreen, 2524
- Biological nitrogen fixation (BNF), 1471
- Biomass burning (BB), 1086, 1518, 1519  
adaptation and mitigation strategies, 1528–1529  
atmospheric composition, impact on, 1524–1528  
emissions data, 1522  
experiment, 1522–1523  
meteorology, impact on, 1523–1524
- Biomass energy  
OLS model, 1432  
ordered logit models, 1431
- Biomass-integrated gasifier/steam-injected gas turbine (BIG/STIG), 2521

- Bio-oil  
ash content, 1323  
moisture content, 1321  
tree species for production, 1318  
yield, 1317, 1321–1322
- Biophysical climate change vulnerability, 642
- Biophysical factors, 510
- Bioremediation, 1162, 1163  
organisms involved in, 1164  
PET, 1165  
in situ and ex situ, 1164
- Blockchain technology, 1108
- Bobirwa, Botswana, 344, 348  
alternative livelihoods, 348–354  
indigenous knowledge of agricultural practices, 354–357
- Boteti, Botswana, 344, 346  
alternative livelihoods, 348–354  
indigenous knowledge of agricultural practices, 354–357  
spatial distribution, farming systems, 350
- Botswana, 1201  
baseline biodiversity in, 1207–1209  
biodiversity sector, 1200  
climate change impacts, 1212–1213  
wildlife tourism in, 1210
- Botswana, farming systems, 344  
alternative livelihoods, 348–354  
flow of methods, 346  
fodder production, implementation plan for, 360  
indigenous knowledge of agricultural practices, 357  
spatial distribution, 349, 350
- Bracharia* grass cultivars, in Kenya, 762  
dry matter yield, 765  
farm trials, 767  
forage quality composition, 766  
MAP, 772  
on-farm evaluation, 762  
participatory selection of, 768–771  
plant height, 763  
soil nutrients, 767  
statistical data analysis, 763  
tiller numbers, 764  
treatments, field design and management, 760  
VKC, 772
- Breeding  
productive animals, 552  
program, 628
- Broiler chickens, 280  
adaptation options to climate change for, 283–292  
adverse effects of heat stress in, 282–283  
breeding for thermo-tolerant strains, 291  
epigenetic adaptation to thermal assaults, 288–289  
feed and feeding manipulation, 285–286  
and heat stress, 281–282  
honey and other phyto-chemicals, 289  
housing system and climate amelioration, 283–285  
organization of enlightenment programmes, workshops and trainings, 292  
stocking density, 287  
water supply, 286–287
- Building Nigeria's Response to Climate Change (BNRCC) project, 2550  
components, 2554  
goals of, 2554  
objectives, 2554  
pilot projects component, 2556–2557  
research component, 2555–2556
- Bundle of assets, 168–170, 174, 177
- Buses in Rapid Transit (BRTs), 2705
- Business model, 1269  
formulation, 1389–1390, 1393–1395
- Bus Rapid Transit (BRTs), 2704, 2706
- C**
- Call detail records (CDRs), 1253
- Cameroon, 93, 106  
agrarian economy, 2171  
agro-ecological zones of, 2174  
data sources and collection, 97–98  
off-farm adaptation strategies, 2177  
on-farm adaptation strategies, 2177  
study site selection and sampling methods, 97  
topography, 97  
women and land tenure in, 2177
- Cameroon agrarian communities in, 2173
- Cameroon coastal region, 263
- Capacity building, 1800
- Capacity Development Programme (CDP), 2634, 2636, 2637, 2639, 2645, 2647, 2649
- Carbon dioxide, 1082–1084, 1097, 1753  
emissions, 2522
- Carbon dioxide fertilization, 619, 634
- Carbon emissions, 741, 851
- Carbon storage, 1325
- Carbon tax, 1064

- Carboxy methyl cellulose (CMC), 1474
- Cashew cultivation, 1795
- Cassava, 65
  - cropping, 1724–1726
  - as food security crops, 242
  - growing season, 627
  - growth, 619
  - in Kenya, 243
  - modelled and actual total yield and production, 631
  - optimum growing temperature, 627
  - planting and harvesting time, 627
  - standard errors of fitted models, 628
  - trends in production and yields, 623–626
- Catfish, 798
- Cattle farmers
  - adaptation strategies to climate change, 207
  - determinants, 205–206
  - perception of climate change indicators, 204–205
  - socio-demographic characteristics of, 203
- Cattle rearing, 570
- Centralized nature, 2030
- Centrifuging pyrolysis oil, 1327
- Cereal production
  - climate change adaptation strategies, 516
  - improved variety, 517
  - livelihood diversification, 519
  - livelihood of farmers, 515
  - in Nigeria, 513
  - productivity, 517
  - rainfall, 515
  - temperature, 515
- Charcoal, in Nigeria, *see* Nigeria
- Charcoal Producer Association (CPA), 1655
- Chicoco Mapping team, 2780, 2785
- Chicoco Maps programme, 2779
- Child commodification, 1827
- CHIRPS, 1619, 1620, 1623
- Chirumanzu resettlement areas
  - adaptation measures by maize farmers in, 405–408
  - additional and unplanned cost of production, 417
  - burden on household members, 413
  - changing planting dates, 406
  - characteristics of A1 maize farmers, 403
  - conservation farming, 407
  - diversification, 408
  - effort spent to facilitate smooth implementation of adaptation measures, 415
  - family labour opportunity cost, 416–417
  - farmers' pain and suffering, 415
  - good crop establishment practices, 407
  - health, wellbeing and safety concerns, 411
  - high cost and scarcity of inputs, 410
  - huge investment costs for adaptation practices, 418
  - increased risk and uncertainty, 410
  - indecision during allocation of scarce resources, 415
  - intangible and indirect costs associated with adaptation measures, 412–414
  - labour related and timing issues, 411
  - lack of mechanical equipment, 410
  - location and climate, 401–403
  - negative effects on productivity and profits, 411
  - problems and dangers associated with adaptation measures, 408–411
  - threat to safety and wellbeing, 410
  - use of drought tolerant varieties, 406
  - wetland farming, 407
  - yield losses related to risks, 417
- Chromolaena odorata*, 1663, 1673, 1674, 1677–1680
- Chronic food insecurity, 572
- Cities and Climate Change Project (CCCP), 2633, 2634
- City of Cape Coast, 2202
- Clean cooking energy, 1281–1284
- Clean development mechanisms (CDM), 1068
- Clean energy, 1425, 1426, 2255, 2257, 2265
- Clean energy technology (CET), characteristics, 1280
- CLEWS, 1057, 1064–1066, 1073, 1076
- Climate adaptation
  - barrier to, 2069
  - low levels of awareness, 2069
  - measures, 1027
  - private sector engagement in, 2066
- Climate change, 4, 153, 163, 172, 176, 263, 341, 342, 344, 354, 357, 359, 424, 516, 618, 622, 714–717, 737–738, 830, 831, 834–837, 839, 841, 843–845, 870, 995–997, 1003, 1054–1056, 1058, 1060, 1061, 1063–1067, 1069, 1072, 1294–1296, 1301, 1304, 1305, 1310, 1366, 1368, 1471, 1557, 1560, 1576, 1586, 1597, 1660–1663, 1677, 1769, 1816, 1938, 1939, 1942, 1947–1950, 2026, 2520–2522, 2524, 2592, 2601–2603, 2715
- adaptation options for broiler chickens, 283–292

- adaptation policy, 1634
- African continent, 851
- on agriculture, 472
- breeding, 135–137
- coastal areas, 264
- crop diseases and effects on crop yields, 745–746
- definition, 276
- direct impact on poultry production, 279–280
- equity and environmental justice, 1074–1076
- and evidences in Africa, 277–278
- and extremes, 1855
- food accessibility, impact on, 743
- food availability, impact on, 742–743
- food security, 133–135
- and food security in coastal Cameroon, 265–269
- food system, impact on, 744
- food utilization, impact on, 743–744
- on forests, 741
- and gender, 2716
- impacts along agriculture value chain, 1818–1821
- impacts on gender roles, 1822–1823
- indirect impact on poultry production, 280
- management, 2409–2411
- microbial biodiversity, 747–749
- mitigation, 739
- Nationally Determined Contributions, 869
- Paris agreement, 1055–1056
- plant and animal pests and diseases, 746
- policy and governance, 1073–1074
- post-harvest, 747
- and sea level rise (CC/SLR), 263
- smallholder farmers, in southern Africa  
(*see* Smallholder farmers, in southern Africa)
- strategy development in Kenya, 2718
- sustainable development strategies, 854
- technology adaptation, 1068
- vulnerability of SIDS to, 2676–2677
- wheat rust disease, 746–747
- Climate change adaptation, 118, 779, 1736–1738, 1753, 1890, 2294, 2567, 2568
- definition, 1498
- and gender (*see* Gender)
- wise water management, 781–782
- Climate change adaptation, Southwest Nigeria
- coping and adaptation strategies, in rural livelihoods, 2507–2510
- data analysis, 2506
- data sources and collection methods, 2506
- perception and coping strategies of respondents, 2513–2515
- perception of climate change, rural households, 2510–2513
- study site selection and sampling methods, 2505
- Climate change adaptation and mitigation (CCAM), 1443, 1456
- agroforestry, 1450
- barriers for adoption, 1457–1459
- cattle, dairy, sheep and goat systems, 1452
- conservation agriculture, 1454–1455
- crop diversity and crop rotations, 1444–1446
- FYM, 1448–1449
- markets, policies and education, for diversified production, 1459–1460
- mulching strategies and green manure cover crops, 1446–1447
- organic farming, 1455–1456
- pH regulation, arable and plant cultivation methods on, 1451–1452
- (silvo-) pastoral systems, 1450–1451
- soil tillage, 1449–1450
- sustainable intensification, 1452–1454
- Climate Change Adaptation Strategy Technical Report (CCASTR), 2554, 2559, 2560
- Climate change and variability, 380
- impact on food security, 390–391
- rural household perception of, 389–390
- Climate change-charcoal chain sector, 2304–2305
- Climate extremes indices analysis, 1942
- Climate finance, 660, 667, 669–671, 673
- Climate Forecast System Reanalysis (CFSR), 2638, 2640, 2641
- Climate Hazards Group InfraRed Precipitation with Station data (CHIRPS), 1941
- Climate-induced food crisis and adaptation, in Africa
- agriculture product diversification, 1795
- capacity building, 1800
- change of pattern, 1800
- climate advisory and extension, 1799
- credit facilities, 1800
- crop diversification, 1795, 1796
- ecosystem-based adaptation, 1796–1797
- increasing acreage, 1799
- multi-sectoral policies, 1801
- national-level policies, for adoption of ecosystem-based initiatives, 1801–1802

- Climate-induced food crisis and adaptation,  
 in Africa (*cont.*)  
 national-level policies, for technology  
 adoption, 1803  
 regional level policies and treaties, 1802  
 regional policies and trade-offs,  
 1803–1804  
 sector diversification, 1795  
 spatial trends, 1792–1793  
 technology and innovation adoption,  
 1797–1799
- Climate induced migration, global perspectives,  
 2047–2049
- Climate Information Services (CIS), 1799
- Climate-land-water-energy-food nexus, 1057  
 biophysical and biogeochemical effects,  
 1063–1064  
 C40 cities programme, 1057  
 energy security, 1058–1059  
 food security, 1062–1063  
 reliable IWM and data, 1059–1061  
 resource planning and management, 1056
- Climate modelling, 2637, 2644, 2645, 2648
- Climate prediction model, 1130
- Climatepreneurship, 2147, 2148, 2150,  
 2159–2164
- Climate resilience, 781  
 water management, 782–784
- Climate resilient, 2040
- Climate services  
 envisioned scheme of, 2462  
 feature of, 2462  
 livelihood security, 2461  
 manifestation of, 2462  
 ‘transformations’ in terms of, 2465
- Climate-smart adaptation practices, 1607
- Climate-smart agriculture (CSA), 226, 595,  
 679, 1443, 1454, 1457  
 aims, 501  
 benefits of, 501–503  
 breeding, 135–137  
 capital investment, 689  
 challenges of, 504–505  
 climate change, 137–138  
 climate change problems, 501  
 criticism directed at, 680–681  
 cropping season, 139  
 crop relocation, 141  
 definition, 497  
 in disaster risk reduction, 681–682  
 diversity of livelihoods, 690  
 ecosystem management, 501  
 efficient resource management, 137–138  
 empowerment of diverse women  
 farmers, 691  
 exploratory-sequential mixed methods  
 design, 682–684  
 food security, 501  
 gender-equal farmer participation, 688  
 gender-equitable resilience capitals,  
 691–692  
 gender-sensitive adoption model, 686–688  
 gender-sensitive policies, 688  
 GIS mapping, 142–143  
 goals for farmers, 685–686  
 integrated renewable energy  
 technologies, 139  
 land use management, 140, 141  
 local-level institutions, 689  
 operationalization, 694–695  
 options available for farmers, 685  
 participatory action research, 690  
 pest management, 142  
 practices by rural farmers in Nigeria,  
 503–504  
 private-sector and viable markets, 690  
 recommendations, 505  
 resource conserving technologies, 140  
 risk information, 692–693  
 risk-informed decision-making, 693  
 technology development, 684–685, 693
- Climate-smart agriculture (CSA)  
 approach, 1813  
 in Africa, 2065, 2066  
 concept of, 2067–2070  
 countries selection, 2070–2074  
 opportunities and impeding challenges,  
 2069–2070  
 perspectives, 2065
- Climate Smart Lending Platform, 2579
- Climate technology, 1057, 1061, 1068, 1076
- Climate variability, 50, 2593, 2601, 2606, 2613,  
 2615, 2616, 2632  
 adaptation to, 716–717  
 on cropping calendar, 1179–1183  
 and water supply, 715–716
- Climate variability and change, 168, 169, 1856  
 challenges, 2322
- Climate variability and rural livelihood security  
 ageds’ experience, 427–433  
 multi-stage selection of ecological zones  
 and aged, 426–427
- Climate variation, 1959
- Climatic risks, livelihood vulnerability to,  
 171–172
- Cloud condensation nuclei (CCN), 1518



- Cloud droplets number concentration (CDNC), 1523, 1529
- Cluster-randomized controlled trial (cRCT), 2490, 2493
- Coastal communities  
livelihoods, 4  
socioeconomic status, 4
- Coastal lagoons, 2222
- Coastal livelihoods, 2718
- Coastal policy, 2223
- Cocoyam (*Colocasia esculenta* (L.) Schott.), 67
- Coffee Directorate, 40
- Coffee production  
adaptation and mitigation, small-scale farmers, 40–42  
climate change challenges, 31–32  
in Kenya, 38–42
- Coffee Taskforce, 43
- Cointegration test, 957, 958
- Collaborative forest management (CFM), 2737
- Collaborative media advocacy platform (CMAP), 2779
- Combustible gases, 1314
- Commercial eco-credit, 2579
- Commercial farms, 79
- Committee on Spatial Information (CSI), 1115
- Communication/climate information element factor, 2286
- Communication for development (C4D), 2149
- Community adaptation to climate change  
crop based autonomous adaptation, 2345–2348  
forest resources based adaptation strategies, 2353–2354  
information assortment techniques, 2344–2345  
livestock based adaptation strategy, 2348–2353  
Metekel Zone, 2342–2344  
off farm activities as an adaptation, 2354–2355  
policy driven and autonomous community resilience, 2355–2359  
recommendations, 2360
- Community-based adaptation (CbA), 2688
- Community-based adaptation projects, 2556–2557
- Community development, CMAP and Chicoco Collective related to, 2777
- Community Earth System Model version 1 (CESMv1), 2473, 2474
- Community eco-credit, 2567
- Community Environment Conservation Fund (CECF), 2573, 2574
- Community-level, 215
- Community rating system (CRS), 1355
- Community resilience, 2177
- Community seed banks, 75
- Composite varieties, maize, 623
- Comprehensive Africa Agriculture Development Programme (CAADP), 1802
- Comprehensive approach, 1357
- Confined aquifers, 814
- Consecutive dry days (CDD), 1942–1946, 1948, 1950
- Consecutive wet days (CWD), 1942–1946, 1948
- Conservation agriculture (CA), 228,  
1454–1455, 1460  
aims, 1335  
barriers to effective uptake of, 1346–1348  
benefits of, 1336–1338  
description, 1335  
economic benefits, 1337  
to enhance adaptation in Taita hills, 1345–1346  
impact on soil carbon, 1336–1337  
impact on soil quality, 1336  
limitations and recommendations for future research, 1348  
soil disturbance principle of, 1335
- Conservation farming, 407
- Conservation tillage, 1827
- Consortium for Small-scale Modelling–Aerosols and Reactive Traces gases (COSMO-ART), 1518, 1521, 1525
- Constraints to adaptation strategies, of farmers, 603  
crop rotation, 611, 613  
harvest date, change in, 610, 612  
intercropping, use of, 611, 613  
irrigation, 609  
mixed cropping, 611, 612  
mulching materials, use of, 611, 612  
non-farm income diversification, 611, 613  
planting date, change in, 610, 612  
planting of cover crops, 609, 610  
resistant crop varieties, use of, 610, 612  
sand bags by river banks, use of, 611, 612  
weather forecasting, use of, 609, 610
- Construct reliability, 1000
- Content analysis, 2028, 2051  
method, 427
- Convective available potential energy (CAPE), 1130, 1132, 1134, 1145–1146, 1149–1156  
environment, 1711, 1716

- Convective days  
 CAPE, 1145–1146  
 moisture flux analysis, 1134–1137  
 vertical wind profile, 1145–1147  
 vertical wind shear, 1138–1143  
 wind divergence analysis, 1138–1140  
 wind vector, 1144
- Cooking energy source, Kenya, 1645–1649  
 cow dung and crop waste, 1649–1650  
 future trends, 1651–1653  
 kerosene, LPG and biogas, 1650
- Cool roof coatings, 2492
- COordinated Regional Climate Downscaling  
 EXperiment (CORDEX), 2368,  
 2382, 2638
- Coordination structures (CS), 997, 998,  
 1000–1004
- Coping strategies  
 challenges, 8  
 governance mechanisms, 17  
 short-term, 17, 18
- CORDEX-Africa, 1941
- Corona virus disease of 2019 (COVID-19),  
 564–566  
 climate change on food security, 573–574  
 cough, 566  
 diagnosis, 568  
 difficulty in breathing, 566  
 fatigue, 566  
 headache, 566  
 high temperature/fever, 566  
 joint pains, 566  
 loss appetite, 566  
 mitigation strategies, 567  
 online survey on Covid-19 awareness and  
 food security, 574–576  
 preventive measures, 567  
 running nose, 566  
 sneezing, 566  
 sore throat, 567
- COSME project, 2719  
 people-centred approach (*see* People-  
 centred approach)  
 recommendations, 2725–2727
- Cost stream, 1392, 1393
- Cote D'Ivoire, 2223
- Coupled Model Inter-comparison Project Phase  
 5 (CMIP5), 2638, 2640, 2641
- Cronbach alpha, 1924–1925
- Cronbach's alpha value, 2659, 2660
- Crop(s)  
 based autonomous adaptation, 2345–2348  
 damage, 2136  
 diversification, 518  
 early planting, 517  
 farming, 2506  
 relocation, 141  
 rotation, 517, 1086  
 yield variability, 628
- Crop livestock farming systems, 228
- Crop-livestock integration systems, 551
- Cropping seasons, 970–972, 982, 983, 986
- Cropping systems, 76
- Cross Border Initiatives (CBI), 1801
- Cross-sector partnerships (CSPs), 1068
- Crowdsourcing technologies, 1117
- Cultural constraints Factor, 2286
- Cycle efficiency, 1962
- D**
- Daily precipitation variability, 1544–1548
- Data desert, 1121
- Data-driven nexus, climate resilient,  
 1065–1066
- Dataset, 1109–1112, 1119–1121
- Decentralization, 2125  
 challenge of, 2464  
 claim for, 2454  
 impact of, 2454  
 process of, 2457  
 targeted processes of, 2454
- Decision making, 1813, 1814, 1816
- Decision support system (DSS), 2634, 2636
- Deep Learning Indaba, 1110
- Deforestation, 510, 1315, 1326, 2032, 2298
- Democratization, 2136
- Demographic Explosion Factor, 2283
- Demolition, 2397
- Dendrochronological studies, 2435–2436
- Desalination of seawater, 1981
- Detention ponds, 822
- DHT sensor, 1744
- Diazotrophy, 1490
- Dichrostachys cinerea* growth rings, 2442  
 climatic variation, growth ring responses to,  
 2439–2441  
 precipitation, 2437–2439  
 samples and data processing, 2436–2437
- Difficult hydrologies, 2330
- Digester design and development, 1385–1386
- Digital elevation model, 1359, 1362–1363
- Digital platforms, delivery of climate  
 information services, 1254
- Dimethyl sulfide (DMS), 1522
- Disability factor, 2285

- Disaster risk reduction, 681–682
- Discount rates, 2327
- Diversification, 408, 2034, 2035, 2038–2041  
of crop, 2307
- Diversity, 832
- Divine Command Theory of Morality (DCTM), 1281
- Do-it-yourself (DIY) adaptation, 1370–1372
- Donor/NGO governance approach, 1267
- Drainage, 2633, 2645, 2647, 2649
- Dredging  
in Accra, 2397  
cost of, 2396  
of drainage channels, 2397
- Drivers, 215, 221
- Drought, in Kenya  
identification and historical trend analysis, 1015–1018  
impact on average food value production, 1019  
impact on gross domestic product, 1020–1021  
impact on maize production, 1018–1019  
impact on undernourished people, 1019–1020  
impact on water security, 1022  
statistical analysis on economic indicators, 1022–1024
- Drought(s), 385, 390, 628, 1968  
North African countries, 1972  
in Tunisia, 1969
- Drought-tolerant maize (DTM), 228
- Drugs, 566
- Dual pathways of responses, 554
- Dynamics-Aerosol-Chemistry-Cloud Interactions in West Africa (DACCIIWA), 1520, 1526, 1528, 1529
- E**
- Earth observation data, 968, 969, 973, 980
- Earth observation (EO) methods, 1115
- East African Community (EAC), and climate change impacts, 779–780
- Ecocentrism, 1287
- Ecological vulnerability, 316
- Ecological zones, 426–427, 433
- Economic(s), 2327  
growth, in Kenya, 950, 952  
plants, 317  
system, 1199
- Economic Community of West African States (ECOWAS), 1802
- Ecopreneurship, 2147
- Ecosystem(s), 514, 1054, 1062, 1063, 1069, 2715  
marine ecosystem in Kwale Country project, 2719–2720
- Ecosystem-based adaptation (EbA), 1757–1758, 1796–1797, 2684–2685
- Ecosystem-based approach, 2199
- Ecosystem health  
CC/SLR constitute a nuisance in, 269  
to CC/SLR induced hazards, 263  
in coastal areas, 268  
and socio-economic and touristic activities, 269
- Ecosystem services, 2198  
and functioning, 2032
- Educational challenge factor, 2283
- Education and awareness, 2109–2110
- Egypt  
environmental changes impacts, on fish production, 799–801  
fish farmer households, 794  
fish farmers' socio-economic characteristics, 796  
location, 791, 792  
scale of operation and purpose for rearing fish, 796  
types of pond, 798  
water sources, 798, 799
- Elaeis guineensis*, 1663, 1673, 1675–1677, 1679, 1680
- Electrical conductivity (EC), 1474
- Electricity generation, 1956
- Electricity generation potential, in Zambia  
available suitable land area, 921–927  
district solar energy theoretical and geographical potential, 929  
district solar PV technical electricity generation potential, 938  
district solar PV technical power potential, 934  
national solar PV technical electricity generation potential, 942  
provincial solar energy theoretical and geographical potential, 933  
provincial solar PV technical electricity generation potential, 937, 940  
provincial solar PV technical power potential, 936  
PV system performance, 913–917  
solar PV potential sites and mapping, 921
- Elalame, 172, 177
- El Nino, 1620, 1625–1628

- El-Nino Southern Oscillation (ENSO), 1615, 1617, 1619, 1620, 1625, 1627, 1628, 2637
- Emanation, 448
- Emerging and Sustainable Cities Initiative (ESCI), 2647
- Emission(s), 851, 855, 858, 859, 866, 871
- Emission Database for Global Atmospheric Research Hemispheric Transport of Air Pollution version 2 (EDGAR HTAP\_v2) dataset, 1522
- Emission factors (EF), 881
- Emission Reduction Purchase Agreement (ERPA), 36
- Energy sources, 1958
- Energy utilization, 1426, 1963
- Engineering solutions, 2401
- Enugu state, 2105, 2106
- Environment, 742, 746–748, 1084, 1085, 1088, 1097, 1098, 1102
- attitudes, 2656, 2658–2662, 2671–2673
  - education, 2658
  - ethics, 1287
  - knowledge, 2658, 2659, 2661–2663
  - shock, 2198
  - temperature, 279, 281, 283
- Environmental changes, fish production, in Egypt and Nigeria, 799–801
- Environmental degradation, 2654–2657, 2669, 2673
- in Nairobi, 2695
- Environmental Geographical Information Systems (E-GIS), 1115
- Environmental justice
- decentralization, 2454
  - field of, 2450
  - societal transformation, 2464
  - societal transformation in terms of, 2449
  - and sustainability, 2457
- Environment impact assessment (EIA), 2700
- Epizootic Ulcerative Syndrome (EUS), 1844
- Erosion, 1443, 1446, 1448, 1449, 1451, 1452, 1454, 1455, 1461
- Essential Nutrition Action (ENA), 2491
- Ethiopia, 380
- household food security status, 391–393
  - location, 381
  - rural household perceptions of climate change and variability, 389–390
  - variability and trends in rainfall and temperature, 384–388
- Ethnicity, 2178
- Ethnobotany, 317
- European Centre for Medium-range Weather Forecast (ECMWF), 1616–1617
- ACC, 1623–1625
  - bias, 1622–1623
  - data analysis, 1619–1620
  - data sources and collection methods, 1619
  - El Nino, and La Nina years, 1625–1627
  - observation and forecast, 1621–1622
  - peak rainfall and dry season, 1627
  - RMSE, 1623
- Evidence-based policy
- development of, 2553
  - importance of, 2551–2552
  - making, 2551
  - in Nigeria, 2554
  - vs. non-evidence-based policy, 2552
  - public policy, 2550
  - public policy making process, 2551
- Exotic vegetables, 473
- Expert-based human intelligence, 1823
- Expert Team on Climate Change Detection Monitoring Indices (ETCCDMI), 202, 1942
- Exposure, 2026
- Extension and advisory services (EAS), 762
- Extreme temperature indices, 1944, 1947
- Extreme weather, 1585, 1602
- events, 700, 709
- F**
- Factor analysis (FA) findings, 2014
- Fadden, 797
- Fairtrade certification, 42
- Fallow system, 1827
- Family labor opportunity cost, 416–417
- Family structure factor, 2283
- Farmer(s)
- in Benue State, 122
  - empowerment, 42
  - in Nigeria, 120
  - smallholder, 120
- Farmer Managed Natural Regeneration (FMNR), 2760
- adaptable approach to land restoration, 2763
  - barriers affecting women participation, 2766
  - benefits in resilience, 2763
  - economic values of, 2760
  - environmental benefits, 2766
  - excess workload, 2766
  - limitation of study, 2769
  - low economic returns, 2767
  - men and women in uptake of, 2764

- recommendations, 2768
- women to participate in, 2765
- Farmer organization provision, 1269
- Farmers, in Ondo State, Nigeria
  - constraints to choice of adaptation strategies, 609–611
  - data analysis, 605
  - limitations, 605
  - socio-economic characteristics, 606–608, 613
- Farmers' participation in climate-smart agriculture, 688
- Farm Input Subsidy Program (FISP), 618, 623
- Farm input supplies, 613, 614
- Farm-led management, 824
- Farm-level GHG
  - emissions, 887
  - mitigation strategies, 879
  - trade-offs, 886
- Farm-level tree-crop-livestock production, 893
- Farm yard manure (FYM), 1448–1449
- Fauna, 510
- Fecal Sludge Management (FSM) Services, 2783
- Female-headed households
  - access to credit and loan, 2110–2111
  - education and awareness, 2109–2110
  - land tenure system, 2109
- Feminist, 2186
- Fertilizer Act, 844
- Financial capital, 174, 176, 177
- Fintech, 1112
- Fipronil, 1662, 1663, 1667, 1673, 1676, 1677
- Fire radiative power (FRP) measurements, 1522
- Firewood
  - ash content, 1323
  - calorific value, 1321
  - CO<sub>2</sub> emission factors, 1315
  - end use emission, 1324
  - tree species for production, 1318
- Fish, 740
- Fisheries, 2032
- Fisheries Commission of West Central of Gulf of Guinea (FCWC), 2237, 2238
- Fish farmers, in Egypt and Nigeria
  - data collections, 795
  - gender, 795
  - households, 794
  - occupation, 795–796
- Fish farming system and operation, in Egypt and Nigeria, 797
  - scale of operation and purpose for rearing fish, 796–798
  - types of pond, 798
  - water sources, 798–799
- Fishing, 2506
  - activities, 1922, 1923
- Fish production, in Egypt and Nigeria, 799–801
- Flood, 2537
  - control, 2395
  - victims, 2538
- Flood disasters, 1706
  - in Burkina Faso, 1708–1712
  - in Nigeria, 1712–1717
- Flooding
  - and adverse effects, 2779
  - in Nigeria, 1355
- Flood-prone areas in Accra, 2390, 2393, 2396
- Flood risk adaptation, Nigeria
  - climate and hydrology, 1359
  - at community level, 1372–1373
  - conceptualization of, 1356–1357
  - digital elevation model, 1362–1363
  - institutional flood adaptation response strategies in, 1372–1375
  - nature of flood risk situation in Kano city, 1357–1358
  - post-flood community response on, 1372–1375
  - public and institutional response to floods, 1369–1371
  - public perception and current state of flood risks and adaptation, 1366–1370
  - relief and geology, 1358
  - socioeconomic characteristics of the residents, 1363–1366
- Flora, 510
- Focus group discussion (FGD), 171, 217, 220, 794, 795, 1697, 2028, 2761
- Food, Agriculture, and Natural Resources Policy Analysis Network, 2103
- Food accessibility, 571, 743
- Food and Agriculture Organization (FAO), 736, 1097, 2520
- Food availability, 736, 742–743
- Food-based farming systems, 89
- Food contamination, 572
- Food fairs, 466
- Food insecurity, 51, 53, 57, 571–573, 1812
- Food production and climate change, 739–742
  - food accessibility, impact on, 743
  - food availability, impact on, 742–743
  - food system, impact on, 744
  - food utilization, impact on, 743–744
- Food safety, 739

- Food security, 133–135, 169, 175–178, 319, 380, 381, 514, 571, 623, 1498, 1790, 1791, 2199, 2226, 2488  
 across sub-Saharan Africa, 243  
 cassava, 242  
 in coastal Cameroon, 265–269  
 consequence of climate change, 570  
 definition, 1791  
 dimensions, 263  
 food accessibility, 571  
 food stability, 571  
 food utilization, 571  
 impact of climate change and variability on, 390–391  
 improvement of, 252  
 and income generation crops, 243  
 prevalence, 262  
 and safety, 263  
 socioeconomic impacts of, 381  
 sweetpotato as, 242
- Food security and nutrition, climate change impact, 744–745  
 crop diseases and effects on crop yields, 745–746  
 microbial biodiversity, 748–749  
 plant and animal pests and diseases, 746  
 post-harvest, 747  
 wheat rust disease, 746–747
- Food shortage, 564  
 Food stability, 571  
 Food system, 744  
 Food utilization, 571, 743–744  
 Forage legume-based crop rotations, 1443, 1455  
 Forage quality analysis, 761, 766  
 Forest-based bioeconomy, 2522  
 Forest ecosystem adaptation, 2348  
 Forest landscape restoration, 2567  
 Forest resources based adaptation strategies, 2353–2354  
 Forestry Research Institute of Nigeria (FRIN), 882  
 Forest sector policy, 2303  
 Fourth industrial revolution (4IR), 1108, 1109, 1122  
 Francophone communities, 2180  
 daughters, 2180  
 Francophone community, women and climate change adaptation, 2185–2186  
 Fully Modified Ordinary Least Squares (FMOLS) method, 956  
*Fushai*, 2416
- G**
- Gantsi, Botswana, 344  
 alternative livelihoods, 348–354  
 indigenous knowledge of agricultural practices, 354–357  
 spatial distribution, farming systems, 349
- Garri*, 172, 173, 175
- Gaseous emissions, 1294, 1302
- Gas flaring, 1402, 2798  
 acid rain, 1406  
 global warming arising from, 1404  
 pollutants from, 1404  
 revenue loss in, 1403  
 rules and regulations governing, 1403  
 threat to, 1403  
 on vegetable cultivation and farmers' livelihood, 1411
- Gender, 1822–1823, 2102  
 access to credit and loan, 2110–2111  
 barriers, 2111–2112  
 biases, 16  
 education and awareness, 2109–2110  
 equality, 7, 2031  
 gaps, 2769  
 gender schema theory, 2104  
 inequality(ies), 7, 2036  
 land tenure system, 2109  
 mainstreaming, 2111  
 power dynamics, 17  
 roles and stereotypes, 2103  
 roles/norms, 2170  
 schema theory, 2104  
 smallholder farmers, in Nigeria, 2106–2107  
 and social inclusion assessment, 2760
- Gender-based violence (GBV), 2723
- Gendered-vulnerability(ies), 680, 2057, 2059, 2060
- Gender-equitable resilience in, 686–688
- Gender response theory (GRT), 1815–1816
- Gender-sensitive policies, 688
- Genetically modified (GM) crops, 2522
- Geographic information system (GIS), 2634, 2636, 2647, 2648  
 mapping, 142  
 spatial analysis, 941
- Germplasm, 467
- Ghana, 2196, 2223  
 agro-ecological locations, 1035, 1036  
 agro-ecological zones in, 1271  
 CIS delivery in, 1267  
 CIS in, 1251  
 farmers in, 1268  
 languages in, 1271

- rural communities in, 1264
  - smallholder farmers, 1250, 1251
  - Sudan savanna agroecological zone of, 1268
  - telecommunications infrastructure in, 1252
  - temperatures, 1248
  - Ghana, climate change adaptation in, 1500
    - binary logistic regression analysis, 1502
    - multistage sampling, 1500
    - predictors of adaptation strategies, 1506–1507
    - predictors of effective adaptation, 1507–1508
    - preliminary regression model, 1501
    - quantitative primary data, 1500
    - respondents' adaptation strategies, 1505
    - variables description and coding, 1501
  - Ghana's Shared Growth Development Agenda, 1803
  - GLDAS model, 970
  - Global Agriculture and Food Security Program (GAFSP), 37
  - Global circulation models (GCMs), 1939, 1941, 1959, 2471, 2477, 2478, 2480–2482, 2697
  - Global climate change, 2613
  - Global climate models (GCMs), 2638, 2640, 2643
  - Global climate system, 700
  - Global Deal for Nature (GDN), 1200
  - Global emissions, 855
  - Global Fire Assimilation System (GFAS), 1522
  - Global fish forecast model, 790
  - Global Framework for Climate Services (GFCS), 1249, 2449
  - Global greenhouse gas (GHG), 133
  - Global positioning system (GPS), 1085, 1252, 1359
  - Global poverty line, 174–176
  - Global Precipitation Climatology Project 1° Daily (GPCP 1dd), 2474
  - Global Pulse, 1114
  - Global solar radiation, 901
  - Global strategy, 1396
  - Global warming, 660, 1535, 1538, 1550, 1838, 2510
  - Governance, 661, 2034
  - Government of Mozambique (GoM), 2632–2634, 2642
  - Government response, 2538, 2544
  - Grains, 513
  - Green economy, 1056, 1064
  - Green gardens, 812
  - Green house emission, 2299
  - Greenhouse gas emissions, 900, 1294–1296, 2521, 2697
    - factors in, 881
    - from agriculture in Nigeria, 876–878
    - from cattle production, 551
  - Greenhouse gases (GHG), 89, 496, 497, 501, 502, 510, 739, 741, 1956, 2145
  - Greenhouse gases (GHG) emissions and climate change, in SSA
    - barriers, 1100–1101
    - biochar, 1097–1098
    - bioenergy, 1092–1094
    - carbon-sequestering grass species, 1087
    - genetic selection of animals, 1094
    - integrated farming system, 1099–1100
    - isotopic tracers, in agricultural field, 1094–1095
    - livestock and manure management strategies, 1088–1092
    - management of residue and adoption of tillage methods, 1086–1087
    - minimizing enteric fermentation and food wastes, 1097
    - nutrient management, in agricultural lands, 1084–1086
    - rice, 1095–1096
    - solid manure, 1098
    - technology-forcing regulations, 1096
  - Green infrastructure, 2199
  - Green manure cover crops (GMCC), 1447, 1448
  - Green roofs, 818
  - Green technology approach, 1295–1296
  - Gross domestic product (GDP), 1296, 2487
  - Groundwater, 715–717, 727
    - discharge, 824
  - GROWEST growth index model, 620–622
  - Guinea Coast, 2479–2481
  - Guinea Current Large Marine Ecosystem (GCLME) programme, 2237
- ## H
- Hassan Addakhil Dam, 1986
  - Hazards, 2027
  - Health and demographic surveillance sites, 2488
  - Health and Demographic Surveillance Systems (HDSS), 2487
  - Heat stress
    - adverse effects in broiler chickens, 282–283
    - and broiler chickens, 281–282
  - Heavy metal determination, 1410–1411

- Heavy rainfall, 169, 171, 176  
 Heckman Probit model, 1605–1606  
 Henties Bay Aerosol Observatory (HBAO), 2251  
 Hierarchical linear regression model, 219–221  
 Horizontal moisture flux divergence (HMF<sub>D</sub>), 1133, 1134, 1136–1138, 1144, 1148, 1149, 1152, 1155  
 Horizontal role dynamics, 1827  
 Hosmer and Lemeshow test, 1502  
 Household(s), 1355, 1360, 1364, 1366, 2176, 2782
  - biomass energy, 1429–1430
  - economic status, 1426
  - electricity, 1428
  - food security status, 391–393
  - formal education attainment, 1437
  - gas, 1428–1429
  - global poverty line, 174–176
  - household energy switching, 1433–1435
  - household traditional energy use, 1435–1436
  - liquid fuel, 1429
  - socio-demographic factors, 1426
  - utility maximization, 1430
 Household food balance model (HFBM), 391  
 Human capital, 169, 172–174, 177, 837  
 Human health, 2029  
 Humic acids, 2261  
 Humid tropics, 715, 724  
 Humus colloids, 2261  
 Hybrid varieties, maize, 623  
 Hydro-climatology, 2370, 2380  
 Hydrogeomorphic approach, 820  
 Hydrological cycle, 714, 732  
 Hydrological droughts, 716, 726, 730  
 Hydrologic variability, 2007, 2021  
 Hydrology
  - characterisation, 2315
  - difficult, 2321
  - stationary, 2313, 2318
 Hydropower, 2030
  - dam, 2327
  - production, 2328
  - reservoirs, 2330
  - sector, 2333
  - Zambezi, 2327, 2332
- I**
- Ibadan, Nigeria
  - Kube Atenda, 1304–1305
  - waste picking activities, at dumpsites, 1306–1309
 Ibiapu Polo Waterfront Community, 2780, 2782  
 IEEE 802.15.4, 1739  
 Ikpo-Obibi, 1662–1664  
 Impact pathways, 2490, 2494  
 Improved cooking stoves, in Kenya, 1644, 1653–1657
  - availability of charcoal, 1655
  - availability of stove, 1656
  - cost of charcoal, 1655
  - high cost, 1655
  - stove design, 1655–1656
 Incentive mechanisms, 2570  
 Incineration, 1302  
 Inclusive, 1814  
 In-depth interview (IDIs), 2151, 2153, 2154  
 Index-based weather insurance (IBWI), 2494  
 Index of biological integrity, 820  
 Indices, 1110  
 Indigenous climate change adaptation strategies, 1822–1823, 1829  
 Indigenous early warning meteorological adaptation strategies, 1829  
 Indigenous farmers, 169, 170, 177  
 Indigenous forecasts (IFs), 663, 665, 1687, 1689, 1691, 1692, 1694, 1695, 1697–1699  
 Indigenous knowledge (IK), 1755–1757, 1760, 1761, 1823  
 Indigenous knowledge systems (IKS), 1753, 1755, 1756  
 Indigenous plant species, 334  
 Indigenous technology, 120
  - structural model of, 126
 Indoor human thermal comfort, 1592, 1596  
 Indoor temperature, 1585
  - air temperature measurements, 1588
  - monitoring sensors, 1588
 Indoor thermal environments, low-cost dwellings
  - ambient air temperature measurements, 1589
  - density distribution, 1590–1594
  - descriptive statistics, 1589–1590
  - indoor air temperature measurement, 1588
  - indoor temperature monitoring sensors, 1588
  - location of Agincourt, 1586
 Inductively coupled plasma optical emission spectrometer, 1411  
 Industrial revolution, 2297  
 Infestation, 482, 484  
 Infiltration systems, 820
  - municipal wastewater, 820–822



- Informal education, 1364  
 Informal waste collectors, 867–868  
 Information requirements (IR), 997, 998, 1000–1004  
 Infrastructure, 2029, 2030, 2033, 2035, 2392, 2400  
 Inland waters, 1925  
 InnovAfrica project, 773  
 Insect-borne diseases  
   midge-borne diseases, 1842  
   mosquito-borne diseases, 1842  
   tsetse fly-transmitted diseases, 1842–1843  
 Institutional arrangements, 2036  
 Institutional environment, 1442, 1460  
 Institutional-socio-earth-economical-technical-systems (ISEETS), 1198–1199  
 Institutional theory, 2104–2105  
 Integrated Data Services Limited (IDSL), 172  
 Integrated farming system, 1099–1100  
 Integrated Management of Natural Resources in ASAL (IMARA), 2760  
 Integrated production and protection (IPP), 2204  
 Integrated renewable energy technology, 139  
 Integrated solid waste management (ISWM), 1294  
 Integrated waste management (IWM), 1060  
 Integrated water resource management (IWRM), 996  
 Intended Nationally Determined Contribution (INDC), 2238, 2633  
 Interactive voice response (IVR), 1255  
 Intercropping, 1827  
 Intergovernmental Panel on Climate Change (IPCC), 342, 473, 474, 570, 739, 1097, 1248, 1759, 2047, 2100, 2272, 2697  
 Intermediary CIS providers, 1251  
 International Coffee Organization (ICO), 41  
 International Energy Agency (IEA), 900  
 International Food Policy Research Institute, 778  
 International Poverty Line (IPL), 1901  
 International Programme on Climate Change (IPCC), 2236  
 Internet of Things (IoTs), 1108, 1738  
 Interpolated climate, 620  
 Intersectionality, 1832, 2171  
   and climate change adaptation, 2181  
 Inter Tropical Convergence Zone (ITCZ), 2637, 2642  
 Inter Tropical Discontinuity (ITD), 1131, 1132  
 IPCC's Fourth Assessment (AR4), 50  
 Irish potato (*Solanum tuberosum* L.), 66  
 Irrigation, 518, 609, 610  
 Irrigation method, 77  
*Isoko*, 170
- J**
- 13-Jan-21, 1472  
 Job market, 1064  
 Joint Africa-EU Strategy (JAES), 2091, 2092
- K**
- Kala azar, 2762  
 Kangundo sub-county, 759  
 Kano State Urban Planning and Development Authority (KNUPDA), 1359  
 Kebele/local level development agents, 2356  
 Kenya, 1642, 1645, 2614, 2656  
   agriculture in, 30–31  
   *Brachiaria* grass cultivars in (*see Brachiaria* grass cultivars, in Kenya)  
   cassava production, 243  
   climate and water profile, climate change impacts, 780–781  
   climate change, 949, 960, 2757  
   climate change contribution to resource-based conflicts, 2625–2628  
   climate change induced resource-based conflicts, prevalence of, 2622–2625  
   climate change policies and regulations in, 31–32  
   coffee sector in, 38–42  
   cow dung and crop waste, 1649–1650  
   economic growth, 950  
   economy, 949  
   energy demand, 1643  
   forms of energy sources, future trends, 1651–1653  
   gender and development targets, 2758  
   Gross Domestic Product (GDP), 949  
   improved cooking stoves, barriers to adoption of, 1653–1654  
   kerosene, LPG and biogas, 1650  
   Kiambu County, 2618  
   land mass, 2614  
   livelihoods, impacts of climate change on, 2620–2622  
   Machakos County, 2618  
   Makueni County, 2618  
   Nairobi city, climate change mitigation and adaptation interventions in (*see Nairobi* city, climate change mitigation and adaptation interventions)

- Kenya (*cont.*)
- rainfall, 950
  - root and tuber crop production in, 67
  - sectoral output, 950
  - sectoral output (measured using GDP per sector), 954
  - semi-arid area in, 246
  - socio-demographic characteristics, 1645, 2619–2620
  - source of energy for cooking, 1645–1649
  - sweetpotato production, 245
  - tea sector in, 32–38
  - temperature, 949, 950
  - tourism in, 949
  - urbanization, 2696
  - weather variability, 950
  - women's perceptions of health risks, firewood stoves, 1650–1651
- Kenya, climate change
- causes and implications, 2049–2050
  - climate smart agriculture, 2058
  - diversifying livelihoods, 2058
  - humanitarian assistance, 2058
  - non-governmental agencies, 2058–2059
  - sharing meteorological information/data with rural households, 2058
  - soil and water conservation, 2058
  - strengthening households' water adaptative capacity, 2057
  - strengthening rural institutions, 2058
  - tree planting, 2057
  - women empowerment, 2057
  - women's livelihood, 2052
- Kenya Coastal Development Project (KCDP), 2724
- Kenya Off-Grid Solar Access Project (KOSAP), 1882, 1884
- Key informant Interviews (KII), 2761
- Kiambu County, 2051, 2618, 2628
- livelihoods, impacts of climate change on, 2622
  - resource-based conflicts, prevalence of, 2624
  - socio-demographic characteristics, 2619, 2620
- Kilimanjaro region, Tanzania
- administrative structure, 834
  - agro-ecological zones, 832, 833
  - data sources, collection methods and analysis, 834–835
  - small-holder farmers' livelihood resilience (*see* Small-holder farmers' livelihood resilience, Kilimanjaro region, Tanzania)
- Kirinyaga County, 758–759
- Kitui County, Kenya
- climate change, 1736
  - pollution, 1741
- Knowledge, attitude and practice (KAP), 2636
- Knowledge Economy Index (KEI), 2524
- Kuzikus, 2435–2443
- Kwale County project, 2719–2720
- Kwara, 300
- crop yield data, 301
  - economic activity, 300
  - location, 299
  - minimum temperature variability, 304
  - rainfall variability, 302
  - State, 512
- L**
- Lagoon
- adaptations, 2232
  - autonomous adaptations, 2229
  - communities, 2222, 2225
  - environments, 2224
  - evolution of storage strategies, 2232
  - flood risk, 2227
  - Muni Lagoon case study, 2233–2234
  - policy implementation and participatory governance, 2235–2240
  - rainfall projections, 2227
  - sea level rise, 2226–2227
  - tropical and sub-tropical regions, 2224
  - vulnerability, 2228
- Laikipia county
- biogas, 1650
  - cowdung and crop residue, 1650
  - firewood collection, 1648
  - health risks, traditional firewood stoves for cooking, 1651
  - household expenses on firewood, 1648
  - households' sources of firewood, 1646
  - kerosene, 1650
  - LPG, 1650, 1653
  - marketing of charcoal, 1655
- Laisamis, 1889
- Lake Otjikoto, 2435–2440, 2442, 2443
- Lake Victoria Basin (LVB), 994, 995, 997–999, 1003, 1004
- Land, 1817, 1818, 1826
- abandonment concept, 78
  - degradation, 2034, 2568, 2569
  - degradation neutrality, 2569
  - grabbing, 2458
  - management sector, 741

tenure system, 2109

Land, water, energy and food (LWEF) sectors  
policy-making and decision making, 1055

Landfill, 855, 859, 861, 865, 866, 868, 869

Landscapes, 2198

Land surface temperature (LST), 2702

Land use, 1723–1731  
management, 140, 141

Land use/cover change (LUCC), 2734

Land-use change and forestry (LUCF) sector, 877

Langrangian multiplier function, 1428

La Nina, 1620, 1625–1628

Large Ensemble Community Project  
(LENS), 2473

Larviciding, 2496

Least significant difference (LSD) procedure, 2741

Length of growth periods, 968, 982

Lesotho Highlands Water Project (LHWP), 2326

Level of adaptation, 215, 217, 219–222

Liberal institutionalism, 2087, 2088

Life cycle assessment (LCA), 2522

Life cycle cost (LCC)  
and return streams, 1388–1389, 1392, 1394

Lifted index, 1710

Lightning imaging sensor (LIS), 1712

Likert scale, 1037

Likert-type scale, 2506

Linear regression, 383

Linking social capital, 215, 219, 221

Liquid applied membrane (LAM), 2492

Livelihood(s), 4, 1498, 1921, 1933, 2226, 2597  
activities, 1236  
concept of, 1229  
definition, 1229  
displacement, 2537  
diversification, 843, 1827  
document community knowledge on, 1234  
and economic diversification, 2038–2039  
household, 1231  
household adaptation to, 1231  
insecurity, 1231  
nature-based, 1243  
negative, 1230  
rural, 1229  
security, 427–433  
shocks and household, 1229  
and social development, 1237  
strategies, 1177  
support, 1228  
sustainable, 1229  
types of, 1236, 1238  
vulnerability, 171–172, 1242  
vulnerability context, 1230

Livelihood resilience, small-holder farmers,  
Kilimanjaro region, Tanzania, *see* Small-  
holder farmers' livelihood resilience,  
Kilimanjaro region, Tanzania

Livestock, 2592, 2593, 2597, 2598, 2601  
based adaptation strategy, 2348  
breeders, 1858, 1859, 1863, 1869  
vulnerability, 1839

Livestock health management and welfare, 550

Livestock production, 883, 1045  
activities toward climate change, 547, 548  
climate change on, 545

Living Standards Measurement Study  
(LSMS), 2488

Loans, 174, 175, 177, 178

Local action, 1383, 1396

Local actors, 2027

Local environmental stewardship, 2721–2723

Local Government Areas (LGAs), 604,  
605, 879

Local varieties, maize, 623

Lodging factor, 2285

Logistic regression model, 1014, 1023

Lokoja of Kogi state, 1716–1717

Long-run relationship, 950

## M

Maasai, 2593

Maasailand, 2598, 2603

Mabira central forest reserve (CFR)  
above ground biomass and carbon  
stocks, 2749  
biomass and soil organic carbon stocks,  
2737–2740  
location and management, 2735–2736

Machakos County, 2051, 2618, 2628  
biogas, 1650  
cowdung for cooking, 1649  
crop waste for cooking, 1650  
health risks, traditional firewood stoves for  
cooking, 1651  
high cost of stoves, 1655  
households' sources of firewood, 1646  
kerosene, 1650, 1653  
livelihoods, impacts of climate change  
on, 2621  
LPG, 1650, 1653  
resource-based conflicts, prevalence  
of, 2624  
socio-demographic characteristics,  
2619, 2620  
stove design, 1655

- Machine learning (ML), 1111, 1115–1119
- Macro fungi, 2258–2260
- Madaoua, 2133
- Madden Julian Oscillation (MJO), 1615, 1616, 1625, 1627
- Maghreb countries  
   water resources and climate change, 1969–1973 (*see also* Algeria; Morocco; Tunisia)
- Mahé Island  
   beach nourishment, 2684  
   sand dune management, 2684  
   in Seychelles, 2683
- Maize, 226  
   climate dependencies, 632  
   cropping, 1724, 1726  
   determinants, 227  
   farming, 402, 405, 406  
   growing seasons, 626  
   growth, 619  
   modelled and actual total yield and production, 630  
   production, in Nigeria, 513  
   profitability, 227  
   profit efficiency, 227  
   Return on Investment (ROI), 230  
   temperature index, 630  
   trends in production and yields, 623–626  
   varieties of, 623
- Makerere University Artificial Intelligence Research Group, 1118
- Makueni country, 2051, 2054, 2618, 2628  
   anticipatory climate change adaptation coping strategies, 1025–1026  
   autonomous climate change adaptation measures, 1024  
   livelihoods, impacts of climate change on, 2621  
   resource-based conflicts, prevalence of, 2624  
   socio-demographic characteristics, 2619, 2620
- Makueni District, Kenya  
   cassava production, 245, 246  
   method of utilization of cassava, 247  
   origin of cassava, 248  
   sweetpotato production, 245, 249  
   types of sweetpotato cultivars, 249
- Maladaptation, 2027, 2118
- Malaria, 2490, 2600  
   control strategies, 837  
   cross-border transmission, 1229  
   fight against, 1228  
   household vulnerability to, 1229  
   morbidity, 1228  
   occurrence, 1235  
   outbreaks, 1228  
   prevalence of, 1228  
   prevention, 1236  
   in Shakawe and Ngarange, 1238  
   transmission, 1244  
   treatment of, 1228  
   vector-borne diseases, 1228
- Mango, 1725
- Mann–Kendall and Sen methods, 2012
- Mara River, 2656
- Marginalization, 2119
- Mariculture, 2253
- Marine environment, 2249, 2265
- Market gardening, 701, 710
- Market survey, 317, 319
- Market vendors, 317
- Marsabit, Kenya, 1883–1884, 2762  
   energy access in, 1884–1886  
   Illaut, 1887–1888  
   Laisamis, 1889  
   Marsabit Town, 1886–1887
- Material recycling facilities (MRF), 851  
   in Addis Ababa, 867  
   definition, 859  
   financing and economic instruments, 861  
   in Johannesburg, 867  
   role-players and decision-makers, 859  
   technical design considerations, 861
- Matobo, 644  
   constraints to small livestock rearing, 650–653  
   feminization of small livestock rearing, 650  
   goat production, 645–649  
   institutional mandate response on small livestock production, 653–654  
   sheep production, 649–650
- Meher, 384
- Mehlich III method, 1474, 1475
- Mesh topology, 1740
- Mesoscale convective systems (MCSs), 1129, 1130, 1132, 1134, 1138, 1145, 1154
- Meteorological agencies, 520
- Meteorological data, 439
- Meteorological drought, 716, 725–727, 729
- Meteorological parameters, 1152–1155
- Meteorology information, 1813
- Methane, 856, 869, 1083, 1086, 1088, 1089, 1091, 1092, 1094, 1096, 1097, 1102  
   reducing feed additives, 552
- Metrics, 1616, 1617, 1622–1628

- Microbial biodiversity, climate change  
  impact, 748  
  biocontrol of plant diseases, 748  
  ocean acidification, 749
- Microfinance banks (MFB), 174, 175, 178
- Micro-financing, 2111
- Micro nutrients solubilizers, 71
- MicroVeg, 473
- Midge-borne diseases, 1842
- Migration, 1110, 1113, 1120
- Mikando*, 2416
- Millennium Development Goals, 2613
- Mineral, 1668
- Ministry of Food Agriculture (MoFA), 1048
- MINITAB software, 1726
- Mitigation, 739, 750, 1086–1088, 1092–1094, 1098, 1100–1102, 1754, 1755, 1758  
  behaviors, 375  
  planning, 1355  
  policies, 1536
- Mixed cropping, 2306, 2508
- Mixed logit models, 1632, 1635
- Mkomazi catchment, 2008
- Mobile-Based-Only platforms, 1255
- Mobile pastoralism, 669, 671
- Mobile phone technology, 2567
- Mobility, 1831  
  factor, 2285
- Model for Ozone and Related Chemical Tracers (MOZART), 1522
- Modeling tools, 1958
- Modelling, 1084, 1085, 1093
- Model standard error, 628
- Moderate resolution imaging spectroradiometer (MODIS), 976, 1522
- Moisture convergence, 1709
- Moisture flux analysis, 1134–1137, 1148–1149
- Mombasa, 2323
- Monthly average solar radiation, 912
- Morocco  
  Bin El Ouidane-Ait El Ouarda, 2365  
  dam construction policy, 2364  
  desalination of seawater, 1989  
  future climate projection, 1987–1988  
  groundwater resources, 1985–1987  
  location, 1970  
  palliative measurements, 1988–1989  
  population, 1972  
  reuse of treated water, 1989  
  surface water resources, 1984–1985  
  temperature variation, 2380  
  water potential and climate change, 1982–1984
- Mosquito-borne diseases, 1842
- Motility test medium (MTM), 1472
- Mountain chains, 719
- Mozambique, 2632, 2633  
  capacity building, 2636–2647  
  climate regions in, 2638, 2640  
  institutional strengthening, 2634–2636  
  Paris Agreement, 2633  
  resilient urban water management studies, 2648–2649
- Mulching, 73
- Mulch ripping, 189
- Multi-actor platform (MAP), 772
- Multi-functional edible urban landscapes, 2198  
  project achievement, 2206–2208  
  project implementation, 2203–2206  
  to resilience, 2197–2200  
  scaling up landscape transformation projects, 2212–2214  
  transformation in practice, 2201–2210  
  urban food security and livelihoods, 2208–2210
- Multilinear regression, 620
- Multi-parent advanced generation inter-cross (MAGIC) & training populations, 137
- Multiple sub-national governance arrangements, 2125
- Multi-Sector Investment Opportunities Analysis (MSIOA), 2328
- Multistage sampling, 1500  
  technique, 2344
- Multivariate analysis of variance (MANOVA), 2619, 2626
- Municipalities, 854, 856, 858, 859, 861
- Municipal Solid Waste Composition, 857
- Municipal wastewater infiltration process, 820–822
- Municipal Water and Sanitation Entity, 2636
- Muni Lagoon case study, 2233
- Muslim community(ies)  
  decision-making power, 2179  
  divorcees, 2179  
  socio-cultural norms, 2179  
  widows, 2179  
  wives, 2178  
  women and climate change adaptation, 2181
- N**
- Nairobi city, climate change mitigation and adaptation interventions  
  depleting aquifers, 2701–2702  
  grey to green infrastructure ratio, 2699–2701

- Nairobi city, climate change mitigation and adaptation interventions (*cont.*)  
 heat island effect, 2702–2703  
 non-motor transport, 2707–2708  
 Thika superhighway, 2704–2706  
 transport infrastructure, 2703–2704  
 transport infrastructure projects, 2709
- Namibia, 2248–2250, 2434  
 aerosol monitoring in, 2250–2252  
 availability of water, 2254–2255  
 climate change and oceans, 2252–2254  
*Dichrostachys cinerea* growth rings  
 (*see Dichrostachys cinerea* growth rings)  
 mushroom cultivation, 2258–2261  
 organic agriculture, 2261–2263  
 seawater desalination in, 2255–2257  
 temperature in, 2434
- Namibian Climate Change Committee (NCCC), 2249
- Namibian mariculture industry, 2254
- National Adaptation Plan of Action (NAPA), 2176
- National Adaptation Program (NAP), 782
- National Adaptation Programme of Action (NAPA) plans, 2238, 2633
- National Adaptation Strategy and Plan of Action on Climate Change (NASPA-CCN) for Nigeria, 2558  
 limitations, 2561  
 process of developing, 2558–2559  
 rating of the process of developing, 2559–2560
- National Agricultural Advisory Services (NAADS), 666, 667, 669, 671
- National Climate Change Action Plan (NCCAP), 782, 2703, 2758
- National Climate Change Policy (NCCP), 2249
- National Climate Change Response Strategy (NCCRS), 782, 2758
- National Climate Change Strategy (NCCS), 2633
- National Climate Change Strategy and Action Plan (NCCSAP), 1801
- National Disaster Management Organization, 1048
- National Disaster Risk Reduction Master Plan, 2633
- National Environmental Management Authority (NEMA), 31
- Nationally Determined Contributions (NDCs), 2789
- National Water Policy of Kenya, 780
- National yield, 622
- Natural environment, 2029
- Natural environmental sustainability, 900
- Natural regions (NR), 216
- Natural Resource Management (NRM), 2757
- Natural resources, 2032
- Natural Resources Conservation Service, 1385
- Nature, 2714, 2715
- Nature-based solution, 2199, 2568
- Nature resources, 903
- Neo-Malthusian concepts, 2137
- Nesting, 215
- Net calorific value, 1320
- Net Food Importing Developing Country (NFIDC), 341
- New Environmental Paradigm (NEP), 2659, 2660, 2662
- Newtonian physics, 1755
- Nexus, concept of  
 analytics framework, 1069–1072  
 climate resilient, 1065  
 nexus securities and environmental protection, 1072–1073  
 research gap, 1069–1070
- Nexus Regional Dialogues Programme (NRDP), 1057
- N-free media (NFM), 1473
- NiCanVeg, 473, 475–477
- Niger  
 agropastoralism in, 2122  
 conflict in, 2119  
 export earnings, 2119  
 lower-tier institutions in, 2120  
 pastoral and agro-pastoral legislation, 2124  
 rainfall, 2119  
 region of, 2122  
 rural code system, 2125  
 sparseness of documentation in, 2120  
 sub-national institutions in, 2122  
 Tahoua Region, 2119
- Nigeria, 168, 170, 176, 426, 456, 457, 602, 792, 793, 1130, 1618, 2223  
 adaptive/palliative measures, 472  
 adaptive management, 1172  
 AET period, 1283  
 afforestation, 2307  
 agricultural adaptation strategies to climate change that reduce charcoal production, 2306–2307  
 agricultural systems, 1171  
 agro-ecological zones, 475, 1186  
 alternative environmental energy, 2302–2303  
 annual variability in rainfall minimum and maximum temperature, 301–306

- cases of deaths, population displacement, damages and victims by flooding, 2538–2543
- catfish, 798
- charcoal production importance, 2295–2296
- climate and crop yield, 306–307
- climate change-charcoal chain sector, 2304–2305
- climate change in, 1170, 1771, 2788–2790
- climate change on agriculture in, 877–878
- climatology and sources of sub-seasonal predictability, 1617–1618
- cooking in urban and rural areas, 1282
- diversification of crop, 2307
- ECMWF sub-seasonal to seasonal precipitation forecast (*see* European Centre for Medium-range Weather Forecast (ECMWF))
- ecological zones, climate change assessment in, 299–301
- ecosystem components, 1185
- effects of charcoal production on agriculture, 2298
- environmental changes impacts, on fish production, 799–801
- environmental problems due to charcoal production, 2298–2299
- equity and justice perspective, 1773
- factors affect production and utilization of charcoal, 2297–2298
- farmers' adaptive strategy, 308–309
- farming communities, 1172
- farming communities' adaptation, 1188
- fish farmer households, 794
- fish farmers' socio-economic characteristics, 795–796
- fish farming operation, 797
- food security, 1174
- forest communities, 1171
- gender and climate change adaptation, rural households (*see* Gender)
- government responses to victims of flooding and challenges, 2544
- greenhouse gas emissions from agriculture in, 876–878
- health implications of charcoal production, 2298
- indigenous adaptation techniques in, 125, 126
- livestock population in, 540–545
- location, 1617
- mangrove, rainforest and savannah agro-ecological zones of, 1179–1183
- map, 1131, 1774
- mixed cropping, 2306
- national adaptation policy, 1769
- natural resource utilization, 1171
- non-biodegradable fuel source in, 1282
- panacea for greening charcoal value chain, 2305–2306
- policy on charcoal production, 2300–2302
- smallholder farmers in, 120
- social vulnerability in, 1174–1175
- strategic recommendations, victims of floods, 2544
- strategies to review forest policy, 2303–2304
- study site selection and sampling methods, 1619
- sudano-sahelian zones of, 529
- tree planting, 2307
- types of pond, 798
- vulnerability and impact of climate change in, 1775
- water sources, 798, 799
- Nigerian agriculture, adaptation and mitigation strategies for, 878–879
- Nigerian Meteorological Agency (NIMET), 2789
- Nigerian national petroleum corporation (NNPC), 172
- Nitrous oxide, 1083, 1084, 1092, 1094, 1097
- Nkonkobe Integrated Development Plan, 1560
- Non-convective day CAPE, 1149–1151
- divergence analysis, 1147–1148
- moisture flux analysis, 1148–1149
- vertical wind shear analysis, 1148–1150
- wind vector, 1149–1151
- Non-governmental organizations (NGOs), 216, 1459
- Nordic Development Fund (NDF), 2634
- Normalized difference vegetation index (NDVI), 2702
- Normalized root mean square error (NRMSE), 2641
- North-East Point beach, 2684
- Northern Rangeland Trust (NRT), 2760
- Number of strategies, 216
- Nutrient management, in agricultural lands, 1084–1086
- Nutrient use efficiency (NUE), 80
- Nutrition, 736, 738, 743, 748, 749
- Nyeri County, 41

**O**

Ocean acidification, 748–749, 2253  
 Oceanic Nino Index (ONI), 1619, 1620, 1625  
 Off-farm income, 2177  
 Ogbomoso metropolis, 439–442, 445  
 Ogun, 300  
   characterization, 299  
   crop yield data, 301  
   location, 299  
   minimum temperature variability, 304  
   rainfall variability, 302  
 Oil exploration, 172, 175, 176  
 Oil palm plantation, 1724, 1725  
 Okavango, 2325  
 Okavango Delta, 1213  
 Okrikan system, 2781  
 Omdena, 1117  
 Omnibus test of model coefficient, 1501  
 Ondo, 300  
   climate of, 299  
   correlation coefficient for cassava, 307  
   crop yield data, 301  
   location, 299  
   minimum temperature variability, 304  
   rainfall variability, 302  
 Ondo State  
   econometric model, 1605–1606  
   farmers' use of weather forecast information, 1607–1608  
   location, 1604  
   policy recommendations, weather information, 1608–1609  
 Ondo State, Nigeria  
   climate, 604  
   constraints to farmers' choice of climate change adaptation strategies (*see* Constraints to adaptation strategies, of farmers)  
   natural vegetation, 604  
   study site selection and sampling methods, 604–605  
 On-farm agricultural practices, 2176  
 Optical densities (OD), 1473  
 Optimum growing temperatures, 626  
 Ordered logit models, 1431–1432  
 Ordinary least squares (OLS), 1432, 1436  
 Organic agriculture (OA), 72, 1453, 1456, 1457, 2261–2263  
 Organic carbon (OC), 1474  
 Organic farming (OF), 1455–1456  
 Organic loading rate (OLR), 1387  
 Organic manure application, 1827  
 Organic matter (OM), 1474

Organic soils, 1085  
 Organic waste, 1060  
 Organization for Economic Co-operation and Development (OECD), 779, 2270, 2525  
*Osusu*, 174, 177  
 Overheating, 1585, 1596  
 Owena, Nigeria  
   age distribution of respondents, 1925, 1926  
   climate variability on fish catch in, 1927–1928  
   fisher folks, climate variability on, 1929–1930  
   fishing equipment, climate variability on, 1932  
   fishing techniques, 1931  
   gender distribution of respondents, 1925  
   inhabitants of, 1922  
   location, 1922–1924  
   secondary occupation and monthly income of respondent in, 1925–1927  
   wind trends and rainfall pattern in, 1933–1934  
 Oxidative stress, 1839

**P**

Pacific oysters, 2253  
 Panel data, 950, 956  
 Paris Agreement, 869, 1217, 2086–2089, 2091, 2094, 2633  
 Partial least square-structural equation modelling (PLS-SEM), 997, 1000  
 Participatory action research, 690  
 Participatory approach, 2241  
 Participatory/co-production approaches, 1269  
 Participatory rural appraisal (PRA), 245, 879  
 Pastoral Code, 2123  
 Pastoralism, 1866  
 Pastoralists, barriers to climate change adaptation, *see* Barriers to climate change adaptation, pastoralists  
 Pastoralists, 2132  
 Pastoral vulnerability, 2593  
 Path dependence, 2318  
 Pathway of responses, 553  
 Payments for ecosystem services (PES), 2570  
 Pearson's correlation coefficient, 725  
 People-centred approach, 2720  
   local environmental stewardship, 2721–2723  
   pro-poor responsible value chain development, 2724–2725  
   women's inclusion and agency, 2723–2724



- Perception(s), 2559, 2561  
farmers, 478–487
- Performance criteria, reservoir, 2366, 2367, 2379, 2382
- Permaculture, 373
- Permeable floors, 813
- Personal protective equipment (PPE), 1308
- Phosphate-solubilizing microorganisms (PSM), 70
- Phosphorus mobilizing fungi, 70
- Photovoltaic (PV) system, 913  
capacity factor model, 917  
energy model, PV array, 914–915  
performance ratio model, 915–916  
technology parameters, 919
- Physical capital, 175
- Planetary boundary layer (PBL), 2639
- Planned adaptation, 2347, 2348, 2410
- Planning, 1371, 1376
- Plans and strategies, 870
- Plantain, 1724
- Plant breeding, 619, 634
- Plant disease, 1112
- Plant diversity, 326, 328  
in local markets within Benin City and environs, 320–328  
utilization pattern in local markets with Benin City and environs, 328–329
- Plant germplasm, 319
- Plant growth index, 632
- Plant growth promotion (PGP), 1471, 1472, 1490–1492
- Plant growth promoting rhizobacteria (PGPR), 71, 1471
- Plant pests, 1112
- Plant products  
description, 316  
local markets in Benin City and environs, 318–335
- Policy, 1055–1057, 1060–1062, 1064–1066, 1068, 1071, 1073, 1076, 2694, 2695, 2700, 2703, 2704, 2706, 2708, 2709  
framework, 2306  
gap, 2240  
makers, 79  
and regulation, 1878
- Political economy analysis (PEA), 2495
- Polyethylene terephthalate (PET), 1160  
bioremediation, 1163–1165  
plastic waste and environmental pollution, 1161
- “Poor man’s food”, 466
- Port Harcourt, Nigeria  
Diobu axis of, 2793  
employment rates in, 2778  
flash flood in, 2784  
informal waterfront communities in, 2779  
location, 2776, 2777  
low-income communities in, 2783  
low-lying waterfront communities in, 2790  
rapid urbanization in, 2778  
sanitation services project in, 2783  
waterfront communities in, 2781, 2799
- Positive feedback loops, 2030
- Potassium hydroxide, 1472
- Potato rhizobacterial isolates  
cultural, microscopic, biochemical and carbohydrate utilization properties, 1475–1479, 1488–1489  
*in vitro* plant growth promoting abilities, 1479, 1481, 1489–1490  
strains, sources and species, 1472
- Potential sites, in Zambia  
available land area, 911–912  
and electricity generation potential, 921–942  
solar PV potential site identification and mapping, 907–910
- Poverty, 2150, 2297, 2537, 2714, 2715, 2718, 2724  
in Africa, 1899  
and diseases through global cooperation, 1898  
in Nigeria, 1899  
through Adaptation mechanism, 1904–1906  
World Bank definition, 1901
- Power relations, 2170
- Praslin Island  
erosion at Anse Marie-Louise on Praslin Island, 2682  
timber piling for coastal protection on, 2683
- PRCPTOT, 1942–1946, 1948
- Precipitation, 439, 1958  
amount, 1621, 1627, 1628  
rates, 970
- Precipitation concentration degree (PCD), 1535  
computation of, 1539  
variability, 1544–1545
- Precipitation concentration index (PCI), 1535  
annual precipitation concentration, 1540–1541  
calculation of, 1538–1539  
model’s robustness, 1542–1543  
seasonal precipitation concentration, 1542  
variability, 1540–1543

Precipitation concentration period (PCP), 1535  
 computation of, 1539  
 variability, 1544–1545

Preliminary regression model, 1501

Prevalence of undernourishment (PoU), 1792

Price and demand management (PDM),  
 1000–1004

Primary and high school students, Embu  
 County, Kenya  
 environmental attitudes, 2660–2662  
 environmental knowledge, 2661–2663  
 perceived prevalent environmental  
 problems, 2660–2661  
 pro-environmental behavior, 2664–2671

Private sector  
 adaptation engagement, 2066  
 in climate adaptation, 2066  
 climate finance, 2066  
 in climate smart agriculture, 2073  
 climate-smart sectors, 2074  
 co-financing role, 2069

Proactive adaption, 2410

Probit model, 1691

Problem Confrontation Index (PCI),  
 1037, 1039

Problemshed, 2331

Production determinants, 2523–2524,  
 2529, 2530

Pro-environmental behavior, primary and high  
 school students  
 community-organized environmental  
 conservation activities, 2669–2671  
 government's pro-environmental  
 conservation policies, 2664–2666

Projected climate change, 634

Proper functioning condition (PFC), 820

Property rights, 2177

Proximate analysis, 1319

Pseudo-global warming (PGW), 2471,  
 2473–2475, 2479–2482

Public-private partnership(s), 1115–1116, 1268

Public water investment (PWI), 997, 998,  
 1000–1004

Push & pull system, 1444

Pyrolysis, 1303, 1314

## Q

Quadratic mean diameter (QMD), 2738

Qualitative information, 473

Quantitative data, 997  
 analysis, 217

Quantitative information, 473

## R

Radon flux density, 439–441, 448, 449

Rainfall, 382, 2471, 2472, 2474, 2477–2481  
 in Algeria, 1973  
 in Maghreb, 1970  
 in Morocco, 1971  
 projections, 1948  
 and temperature trends, 383  
 variability at Oran and Tiaret stations, 1974  
 variability in the Mediterranean region, 1972

Rainfall variability, in Bamenda I  
 inter-annual rainfall variability and  
 anomalies, 720  
 monthly rainfall variability and anomalies,  
 720–722  
 rainy days and rainfall intensity, 722–723  
 seasonality index, 724–725  
 standardized precipitation index, 723–724  
 water supply (*see* Water supply, in  
 Bamenda I)

Rainfall variability, in Santa, 700  
 interannual anomalies, 704  
 monthly basis, 704  
 rainy days and rainfall intensity, 705–706  
 tomatoes production (*see* Tomatoes  
 production, in Santa)

Rain fed agriculture, 380

Rainforest Alliance, 38

Rainwater harvesting, 818, 841

Rainy season, 2227

Ramsar Convention, 2236

Ranching, 553

Random-effects model, 217–218

Random intercept model, 218

R and SAS estimates, 1638

Raymond Mhlaba Local Municipality  
 (RMLM), 1557  
 access to water, 1574  
 adaptive capacities changes, 1569–1570  
 adaptive capacity levels for individual  
 communities, 1574  
 age profiles on resilience, 1576  
 annual income levels, 1575  
 automated allocation of scores for  
 community income levels, 1562–1564  
 automated creation of new shapefile and  
 attribute table, 1564  
 automated creation of new shapefile and  
 saving adaptive capacity, 1567  
 datasets, 1560  
 demographic indicators for assessing and  
 tracking adaptation, 1561  
 literacy levels, 1575

- location of, 1559
- Nkonkobe Integrated Development Plan, 1560
- summation and ranking of IndicatorsScores table, 1566
- RCA4 model, 1977
- Recombinant Inbred Lines (RILs), 136
- Reducing Emissions from Deforestation and Forest Degradation (REDD+), 1758–1759, 1762, 2570
- Redundancy, 834
- Redundancy analysis (RDA), 1670, 1672, 1673, 1675
- Refuse derived fuel (RDF) plant, 1303
- Regional climate models (RCMs), 1939, 1941–1943, 1950, 2638
- Relation-based indigenous adaptation strategies, 1826–1829
- Relative deprivation theory, 2615
- Relative operative characteristics (ROC), 1616
- Reliability, 2367
- Relocation from climate risk zones, 503
- Renewable energy (RE), 900, 901, 904, 1957 technologies, 1384
- Renewable Resource Centre (RRC), 1297, 1298
  - biogas generation and compression, 1299–1300
  - high-temperature incinerator, 1302–1303
  - home composter, 1303–1304
  - mushroom cultivation, 1300
  - refuse derived fuel plant, 1303
  - wood charcoal kiln, 1301–1302
- Research and development (R&D), 2524, 2528
- Research Unit (RU), 2487
- Reservoir(s), 1958
  - BEO-AEO complex, 2365
  - Bin El Ouidane, 2365
  - compensatory, 2365
  - evaporation from, 2369
  - management model, 2366
  - operations, 2369, 2376, 2380
  - sediment, 2369
- Resident age factor, 2284
- Residential dwellings, 1585
- Residue management methods, 1723
- Resilience, 342, 359, 681, 695, 1035, 1056, 1057, 1071, 1076, 1759–1760, 2197–2200, 2367, 2603–2606
- Resilience-building, 681, 691, 692
- Resilient, 474
- Resource-based indigenous adaptation strategies, 1826–1828
- Resource conserving technologies (RCTs), 140
- Resource management, 137
- Restoring ecosystems, 1758
- Retention systems, 824
  - redirecting water in, 819
- Reverse osmosis (RO) desalination, 2256
- Reverse osmosis system, 824
- Rhizobacterial cultures
  - cultural, microscopic and biochemical characterization, 1472
  - in vitro* experiments, 1472–1473
  - potted experiment, 1473–1475
- Rhizobacterial treatments, 1481, 1484, 1488
  - growth and yield of potted potatoes, 1490–1491
  - physicochemical properties of potato nutrient contents, 1487
  - physicochemical properties of potato rhizospheric soils, 1485
  - potato biometric parameters, 1482
- Rice production, Nigeria, 513
- Rift Valley Fever (RVF), 1842
- Rising temperatures, 171, 172, 176
- Risk-informed decision-making (RIDM), 693
- Risk management, 1038, 1960
- Riskscape, 2450
- Robotics technology, 1058
- Rock armoring, 2682
- Role commodification, 1831
- Role diversification, 1827
- Root mean square error (RMSE), 1616, 1619, 1623, 1626–1628, 2016
- Rotation cropping, 1798
- Rural aged, 427, 428, 431–433
- Rural electrification in Kenya, 1881–1883
- Rural farmers' drought adaptation, in Ghana
  - adaptation measures, agro-ecological locations, 1042
  - constraints to drought adaptation, 1039–1041
  - data processing and analysis, 1037
  - descriptive statistics, of farm household characteristics, 1039
  - drought monitoring, 1047
  - farm household characteristics and adaptation capacity, 1037–1039
  - migration, 1044
- Rural households, 1387, 1390, 1396
- Rural livelihoods, 2046, 2059, 2502–2504, 2507–2511, 2515
- Rural population characterization, in Akwa Ibom State, 2273–2275
- Rural resilience, 1651

- Rural-urban, 1830, 1831  
 transformation, 811
- Rural women entrepreneurship development, in  
 Nigeria  
 awareness of climate change and impacts on  
 business activities, 2153–2156  
 climate adaptation strategies, 2145–2146  
 climatepreneurship intervention,  
 2159–2164  
 coping strategies, 2159  
 experiences of participants and livelihood  
 practices, 2156–2158  
 socio-demographic characteristics of  
 respondents, 2153–2154
- Rwenzori region, Western Uganda  
 agro-ecological diversity, 1689  
 arable farmers in (*see* Arable farmers, in  
 Rwenzori region, Western Uganda)  
 barriers to climate change adaptation,  
 pastoralists (*see* Barriers to climate  
 change adaptation, pastoralists)
- S**
- Sahel, 2120, 2475, 2479–2482
- Samasource, 1109
- Sand dams, 822
- Sand dune management, 2683–2685
- 2017 SAN Standard, 44
- Santa agrarian basin, Cameroon  
 data collection, 702  
 location, 702–703  
 rainfall variability, 704–706  
 tomatoes production, 706–709
- Satellite rainfall products (SRPs), 2474
- Savannah, 2479–2482  
 atmospheric temperature, 534  
 categories of, 525  
 features of, 539  
 livestock production, 544  
 livestock production characteristics,  
 536–540  
 livestock stakeholders in, 529  
 precipitation, 531  
 rainfall trend/patterns, 533  
 relative humidity, 534  
 temperature humidity index, 535, 537
- Savings and credit organizations (SACOs), 670
- Scientific forecasts (SFs), 663, 665, 1686–1689,  
 1691, 1692, 1694, 1698, 1699
- Sea level rise, 2226  
 climate change and, 268  
 climatic and non-climatic factors, 263  
 on developing countries, 267  
 and sea wave heights, 264
- Seasonal classifier, 2008
- Seasonal food insecurity, 572
- Seasonal forecasting, 2422
- Seasonality, 2375, 2376
- Seasonality index (SI), 724–725
- Seasonal variations, 328
- Sea surface temperature (SST), 2637
- Seawater desalination, in Namibia, 2255–2257
- Seaweed farming, 5, 2724–2725
- Secretion, 566
- Sectoral output in Kenya, 950
- Sedentary pastoralism, 669
- Sedimentation, 715, 717, 720, 725, 823
- Seeds Act, 844
- Seed varieties, 75
- Semi-arid region of Cameroon  
 characterization of sorghum farmers’  
 adaptation strategies, 157–163  
 climate hazards and sorghum farmers’  
 adaptation strategies, 149–153  
 Sahelian farmers’ adaptation strategies  
 typologies, 153–157  
 socioeconomic characteristics of sorghum  
 farmers, 149
- Senegal Agriculture Programme, 1803
- Sensitivity, 2026
- Sensor node, 1742
- Sentientism, 1287
- Seychelles  
 adaptation measures in, 2681–2685  
 barriers to climate change adaptation,  
 2686–2688  
 beach nourishment, 2683  
 climatic and non-climatic-induced  
 vulnerability, 2677–2681  
 ecosystem-based adaptation, 2684–2685  
 hard engineering techniques, 2681–2682  
 options for overcoming adaptation barriers  
 in, 2688–2690  
 rainfall patterns, 2678–2681  
 sand dune management, 2683–2684  
 soft engineering techniques, 2682–2685  
 temperature and rainfall variability,  
 2677–2678  
 timber piling, 2683
- Seychelles’ Conservation and Climate  
 Adaptation Trust (SeyCCAT), 2690
- Shellfish, 2253, 2254
- Shit/Excreta Flow Diagram (SFD), 2787
- Short Message Services (SMS), 1255
- Short-rotation woody crops (SRWC), 2521

- Siderophore(s), 1490  
production index, 1473  
units, 1473
- Silvopastoral systems, 1450–1451
- Simanjiro District, 2593
- Simulating and forecasting, 450
- Skill, 1614–1617, 1620, 1623, 1625, 1627–1629
- Smallholder farmers, 340–342, 346, 354, 646, 649, 654, 1791, 1795–1800, 1802, 1805  
demographics, 372  
to implement agroecology, 368  
researcher and participant, 369  
skills and knowledge, 366  
in South African, 364
- Smallholder farmers, in Nigeria, 2106–2107
- Smallholder farmers, in southern Africa  
data gathering and analytical framework, 216–217  
hierarchical linear regression model, 219–221  
multi-level estimation of determinants of level of adaptation, 217–221  
public and private extension services, 222  
random-effects model, 217–218  
random intercept model, 218
- Small-holder farmers' livelihood resilience, Kilimanjaro region, Tanzania  
conservation of water sources, 840  
government, role of, 843–844  
household decision making and female empowerment, 836–837  
human capital, 837  
livelihood diversification, 843  
planting crops, climate variability, 840  
rainwater harvesting, 841  
social capital, 838–839  
soil fertility, management of, 841–842
- Smallholder farming, 682  
CIS delivered with ICTs, 1263  
communities, 403  
governance model, 1267  
and household food security, 1248
- Small island developing states (SIDS), 2676
- Small livestock, Matobo, 640  
and climate change nexus, 645–650  
constraints to rearing, 650–653  
feminization, 650  
goat production, 645–649  
institutional mandate response on, 653–654  
sheep production, 649–650
- Small-scale farmers, adaptation and mitigation measures  
coffee production, 40  
tea production, 34
- Small-scale farmers, in Africa, 107  
adaptive measures, 94–95  
adverse effects of climate change, 91–92, 102  
barriers to adaptation, 95–96  
binary logistic regression model, 105–106  
continuous independent variables, 103–104  
direct cause-effect relationship, 107  
effectiveness of, 96  
farmer perceived factors, 100–101  
non-cause-effect relationship, 107  
perceptions of climate change, 90–91  
qualitative independent variables, 104–105  
vulnerability to climate change, 92–93
- Small-scale fishing (SSF) communities, 2225
- Smart agricultural practices, 1499
- Smart agriculture, 2058
- Smart decisions, 1607–1608
- Social and gender relation, 1818
- Social capital, 174, 175, 177, 215, 219, 221, 838–839, 1348, 2418
- Social cohesion, 2615
- Social disorganization theory, 2615
- Social ecological systems (SES), 831
- Social-economic status, 2658
- Social inequalities, 2425
- Social protection systems, 2420
- Social vulnerability, to climate variation, 2281
- Societal transformation  
analytical concept, 2450  
beneficial, 2461  
enforced, 2463  
environmental justice, 2449  
fatal, 2463  
hailing processes of, 2455  
hotspot of, 2449  
integrative, 2463  
irrevocable, 2449  
processes of, 2464  
sustainability in, 2457
- Socio-ecological model (SEM), 2148
- Socio-ecological system, 661, 2037
- Socio-economic characteristics, 664–666
- Socio-economic inequalities, 851
- Socio-economic livelihoods, 2389, 2390, 2394
- Soil  
carbon stocks, 1730  
chemical properties, 1666, 1670, 1672–1675  
composition, 746  
conservation management measures, 1826

- Soil (*cont.*)  
erosion, 737  
fertility, 841–842, 2262  
mineral analysis, 761  
physical properties, 1666  
sampling, 1668
- Soil fertility status in Taita Hills, 1343
- Soil moisture, 739, 745  
to agricultural performance, 438  
and climate, 439  
climate change and, 439–440  
forecasted, 439  
forecasting, 443  
hydrological processes, 440  
investigation, 443  
observation, 444–445  
over Ogbomoso, 440  
precipitation, 439  
simulation, 439, 443, 445  
statistics, 438  
variability, 439
- Soil organic carbon  
analysis of variance for, 2749  
estimation, 2740  
least squares means for, 2748
- Soil organic matter (SOM), 72
- Soil productivity, 1723
- Soil properties, 1728–1731
- Soil Water Assessment Tool model (SWAT model), 440, 441, 443, 450
- Soil water balance, 622
- So-Klin application, 1503, 1504
- Solar power, 1960
- Solar PV systems, in Zambia  
district solar PV technical power potential, 934  
electricity generation technical potential model, 920–921  
environmental and social impacts, 904  
land elevation, 909  
land use/cover, 908  
provincial solar PV technical power potential, 936  
restricting issues, 904–907  
roads and railways network, 909  
settlement and community interest sites, 909  
surface water bodies, 909  
transmission line network, 910  
wildlife sites, 908
- Solar radiation intensity, 901
- Solar reflectance, 2492
- Solar reflectance indices (SRIs), 2492
- Solubilization index (SI), 1473
- Sorghum farmers  
characterization and adaptation strategies, 157–163  
climate hazards and adaptation strategies, 149–153  
socioeconomic characteristics of, 149
- Source control, 817–820
- South Africa, 1557
- Southern Africa, climate change adaptation, 1760–1761  
ecosystem-based adaption, 1757–1758  
knowledge, 1755–1757, 1761  
mitigation, 1754, 1755  
REDD+, 1758–1759  
resilience, 1759–1760  
vulnerability, 1757
- Southern Africa, 2026, 2028
- Southern Ghana  
effect of site location on soil properties, 1728–1731  
farming sites, 1723–1725  
sampling and analysis, 1726
- Southern Nigeria  
experimental design, yam cultivation and treatments, 1666–1668  
mean annual rainfall and temperature, 1665  
soil chemical properties, 1666, 1669–1675  
soil physical properties, 1666  
soil sampling and chemical properties analyses, 1668–1669  
termites sampling, 1669  
yam tuber yield and termites, 1670–1676  
yam yields, 1669
- Southern West Africa (SWA), 1520  
adaptation and mitigation strategies, 1528–1529  
atmospheric composition, impact on, 1524–1528  
biomass burning experiment, 1522–1523  
meteorology, impact on, 1523–1524
- Southwest Nigeria  
primary livelihoods of rural households, 2506–2507  
vegetation, 2505  
wet and dry seasons, 2505
- Spatial equilibrium models, 1073
- SPI, *see* Standardized precipitation index (SPI)
- Spontaneous adaptation, 2410
- Stakeholder(s), 2558–2561  
dissemination event, 2206
- Standard Assessment of Mitigation Potentials and Livelihoods in Smallholder System (SAMPLES), 881

- Standardized precipitation index (SPI), 723–724
- Stationarity, 2318
- dynamic, 2318, 2333
- Statistical analysis, 1475
- Statistical Package for Social Sciences (SPSS), 1625
- version 17, 202
- Stereotypes, 2102–2104
- Stochastic techniques, 2319
- Stockholm Environment Institute (SEI), 2760
- Storm-water runoff, 822–823
- Strain theory, 2614
- Stranger neighbouring households, 416
- Stratospheric Ozone Experiment (STRATOZ), 1519
- Stream flow, 716, 726, 727, 2006
- Stressors, 2027
- Students' pro-environmental behavior
- community-organized environmental conservation activities, 2669–2671
- government's pro-environmental conservation policies, 2664–2666
- Sub-Saharan Africa (SSA), 50
- adaptation strategies, 2486
- climate smart agriculture in, 2067–2069
- climate smart agriculture opportunities and impeding challenges in, 2069–2070
- GHG emissions, in agricultural systems (*see* Greenhouse gases (GHG) emissions and climate change, in SSA)
- national governments in, 2080
- population growth in, 2065
- Sub-seasonal to seasonal (S2S) forecast, 1616–1617, 1628
- Sub-seasonal to seasonal (S2S) prediction, 2020
- Subsistence agriculture, 2171
- Subsurface dams, 822
- Sudano-sahelian* zones of Nigeria, 540, 544, 546
- Sulfur indole motility (SIM), 1472
- Surveyed respondents characteristics, 1635
- Sustainability, 2367
- Sustainable agriculture, 319
- Sustainable Agriculture Network (SAN), 35
- Sustainable climate change adaptation, 2504
- Sustainable development, 782, 1900, 2027
- Sustainable development goals (SDGs), 89, 133, 169, 564, 572, 1055, 1057, 1058, 1061, 1063, 1069, 1071, 1073, 1076, 1115, 1877, 2100, 2236, 2568, 2613
- Sustainable ecosystem management, 1758
- Sustainable environmental development, 316, 335
- Sustainable intensification (SI), 1452–1454
- Sustainable land (use) management (SLM), 1454
- Sustainable livelihood framework, 1175, 2594
- Sustainable livelihoods approach (SLA), 2234
- Sustainable national energy mix, 943
- Sustainable technologies, 1295
- Sustainable urban drainage systems, 811
- Sustainable water allocation, 2007
- Sweet potato, 65
- across sub-Saharan Africa, 243
- constraints to production, 245
- in East African region, 245
- as food security crops, 242
- growth, 619
- international trade in, 245
- modelled and actual total yield and production, 631
- model standard error, 628
- post-analysis, 253
- production in Matiliku Division, 248
- trends in production and yields, 623–626
- SWOT analysis, 355
- Synthetic fertilizers, 1470
- T**
- Taita hills
- climate variability in, 1339–1341
- conservation agriculture to enhance adaptation in, 1345–1346
- crop production trends, 1341–1344
- location, 1338
- Tanzania, 2592
- climate change adaptive strategies, 2601–2603
- climatic trends, 2595–2597
- household vulnerability, 2597–2601
- livelihood profiles, 2597
- local institutional mechanisms and climate change resilience, 2603–2606
- sustainable livelihood framework, 2594
- Tanzania Coffee Research Institute, 835
- Tea production
- adaptation and mitigation measures by small-scale farmers, 34
- climate change challenges, 34
- in Kenya, 32–38
- Technology combinations, CSA, 234

- Telfairia occidentalis*, 1409  
 growth indices on gas flared soil and non-gas flared soil, 1412–1415  
 heavy concentration on biochar remediated soils from gas-flare and non-gas flare, 1412–1414  
 procurement, cultivation and growth indices of, 1410
- Temperature, 1938–1943, 1946, 1948–1950, 2473, 2475–2477  
 response function, 626  
 variation, 99
- Temporary food insecurity, 572
- Termites, 1661–1663, 1669, 1670, 1672, 1675–1677  
 mounds, 1662, 1665, 1668  
 sampling, 1669
- Terrestrial non-vector borne diseases, 1843–1844
- The high plateaus of eastern Morocco, 1855
- Thermal comfort zone, 281
- Thermal discomfort, 1590, 1591
- Thermal emittance, 2492
- Thermal plants, 1963
- Thermochron iButton, 1588
- Thermodynamic parameters, 1709, 1712
- Thermoregulation, 279, 289
- Tick-borne diseases, 1843
- Tie-ridging, 74
- Tilapia, 798
- Timber piling, 2683
- Time series analysis, 1339
- Tipping points  
 anthropocene risks, 1194  
 biodiversity, 1202  
 for climate change, 1214  
 ecosystem management, 1202  
 and emergence, 1195–1196  
 emergence and innovation, 1196–1198
- Tissue culture, 80
- Togo, 2223
- Tomatoes production, in Santa, 701  
 agrochemicals and fertilizers, 708  
 cropping system, 708  
 farm level adaptation strategies, 706  
 improved varieties of tomatoes, adaptation to, 707  
 irrigation method, 707–708  
 off farm and nonfarm level activities adaptation strategies, 709
- Top-Down assessment procedure, 2364, 2366, 2382
- Trace elements, 1663, 1668–1670, 1673, 1677
- Traditional biomass energy, 1431–1437
- Traditional knowledge, 1755
- Transformation, 682
- Tree-crop-livestock production optimization model, 890
- Tree planting, 2307
- Triple crisis  
 description, 2714  
 people-centred approach, 2721  
 (*see also* People-centred approach)
- Triple Helix (TH), 1876  
 in Africa, 1877–1879  
 interaction model, 1877  
 for sustainability and climate change, 1879  
 university role, 1876
- Tropical Easterly Jet (TEJ), 1129, 1132, 1145
- Tropical Pesticides Research Institute Act, 844
- Tropical Rainfall Measuring Mission (TRMM), 1132, 1134, 1135, 1141–1143, 1150, 2474, 2477, 2479, 2480  
 3B43 products, 979
- Tropospheric Ozone Experiment (TROPOZ), 1519
- Tsetse fly-transmitted diseases, 1842–1843
- T-test approach, 1001
- T-test statistics, 103
- Tunisia  
 agriculture, 1972  
 climate of, 1971  
 future climate projections, 1992–1997  
 location, 1970  
 population, 1972  
 water for irrigation, 1971  
 water potential and climate change, 1990–1992  
 water saving measures, 1997–1998
- Twenty-fifth Conference of Parties (COP 25), 2086–2088
- U**
- Uganda, climate change adaptation  
 economic, 672  
 human resources, 672  
 institutions, 672  
 political will, 672
- Uganda Wildlife Authority, 662
- UK Department for International Development, 831
- U.N. 2030 Agenda for Sustainable Development, 1115
- Undernutrition, 2488



- Underutilized indigenous vegetables (UIVs), 473  
 African, 484  
 negative effects, 474
- UN Environment Adaptation Gap Finance Report, 779
- Unintended adaptation effects, 416
- United Nations Development Programme (UNDP), 1759, 2107
- United Nations Framework Convention on Climate Change (UNFCCC), 785, 1790, 1900, 2047, 2249
- United Nations Millennium Project, 1425
- United Nations World Food Programme (UNWFP), 572
- Universalistic science, 1756
- Universal primary education (UPE), 671
- University of Namibia, 2257
- Unlocking Climate Finance, 2079
- UN World Data Forum, 1115
- UN World Water Development Report, 779
- Upepo Technology, 1118
- Urban agriculture, 2199
- Urban Community Resilience Assessment programme, 2791
- Urban greenspace, 2199
- Urbanization, 326, 2194–2195
- Urban landscapes  
 evolution of, 2195–2197  
 multi-functional edible, 2198  
 (*see also* Multi-functional edible urban landscapes)
- Urban morphology, 851, 854, 856, 861, 863
- Urban Planning, 852
- Urban sustainability, 2199
- US Environmental Protection Agency, 1082
- Ushahidi, 1116
- V**
- Vaal River System, 2320
- Value-added chain, 1306
- Value chain, 2570, 2724
- Vea catchment, Ghana, 1940  
 adaptation strategies, poverty and sustainable livelihoods, 1949–1950  
 annual rainfall and temperature projections and trends, 1942–1943  
 climate change and climate extremes impacts, 1946–1949  
 climate extremes indices analysis, 1942  
 extreme rainfall indices, trends and projected changes in, 1943–1946  
 map, 1940  
 temperature extreme indices projections and trends, 1944–1948
- Vector control, 2496
- Vegetative cover, 1961
- Vernonia amygdalina*, 1663, 1673, 1678–1680
- Vertical wind shear, 1132–1134, 1138–1143, 1148–1150, 1152
- Village knowledge centre (VKC), 758, 762, 772
- Village savings and loan association (VSLA) schemes, 2725
- Village savings and loans associations (VSLA) model, 2580
- Voice/audio and video messages, 1255
- Volumetric rainfall, 1708
- Vulnerability(ies), 515, 583, 585, 591, 692, 716, 1343, 1354, 1357, 1366, 1377, 1499, 1757, 1821–1822, 1860, 2027, 2198, 2597–2601, 2676–2677  
 assessments, 688  
 context, 1176  
 definition, 2272  
 and gender (*see* Gender)  
 hotspots, 1959  
 lagoon, 2228  
 vulnerability, 2273
- Vulnerability index (VI), 2105, 2107, 2108
- W**
- Wald statistics, 1506
- 2007 Warehouse Receipt System (WRS), 844
- Waste management, 850–856, 859, 861, 863–866, 868–870, 1294–1296, 1304, 1305, 1391, 1396  
 carbon emissions effects, 851  
 daily ratio, 855  
 disposal methods, 858  
 industrial emissions, 851  
 informal waste collectors, 867–868  
 material recycling facilities, 851, 859  
 private contractors and informal waste pickers, 858  
 sustainable urban planning, 852–853  
 urban waste impediments, 864–865  
 and utilization, 550  
 waste collection, 857  
 waste composition, 856  
 waste generation, 856  
 waste services and infrastructure, 856
- Wastepickers Empowerment Programme, 868

- Waste picking, dumpsites  
 business apprenticeship, method of, 1307  
 business optimization and improvement, 1308  
 category of workers and prices of items, 1307  
 factors, 1308  
 quantity, 1308–1309
- Water, sanitation and hygiene (WASH), 2635, 2637, 2641, 2647, 2648, 2650  
 climate impacts on, 2639
- Waterberg, 2436–2439, 2443
- Water catchment, 729  
 construction of life fences, 730  
 local population in catchment protection, 730–731  
 slanting and enlarging riverbanks, 730  
 water friendly trees, planting of, 730
- Water–energy–food (WEF), 1798
- Water harvesting techniques, 644
- Water pricing, 1062
- Water resource management frameworks  
 adaptation and ICT frameworks, 996–997  
 analytical framework, 996  
 AVE, 1001  
 data analysis, 998–999  
 data collection, 998  
 demographic information of respondents, 1000  
 discriminant validity, 1001  
 estimation of path coefficients, 1001–1002  
 outer loading, 1000–1001  
 respondents' profile, 999  
 study hypotheses, 997–998
- Water resources  
 in Algeria, 1974  
 availability, 2317  
 climate change impact on, 2330  
 climate change on, 2313  
 diversity of, 2318  
 impact of climate change on superficial and underground, 1975–1976  
 lifetime of, 2318  
 Maghreb countries and climate change, 1969–1973  
 physical context, 2321  
 and services dependent, 2312
- Water Resources Authority (WRA), 780
- Water Resources Management Authority (WRMA), 780
- Water resources management, in Kenya  
 Agenda 2030 SDGs, 784–785  
 climate resilience, 782–784  
 wise water management, climate change adaptation, 781–782
- Water risks, 152, 158
- Water security, 1061, 2315
- Water shortage, 722, 726, 729
- Water source control, 817–820
- Water supply, 2323  
 mining or agricultural business, 2322  
 urban, 2325  
 Windhoek's, 2325
- Water supply, in Bamenda I  
 catchment protection and water management measures, 729–731  
 distribution facilities, adaptation on, 731  
 drilling of boreholes wells, 728  
 droughts and natural supply, 726–728  
 high rainfall intensity and water system, 726  
 Pearson's correlation coefficient, 725  
 rainwater collection system, use of, 728–729  
 spring source coverage, 728  
 storage facilities, adaptation on, 731
- Water use efficiency system, 1950
- Waterways, 2397, 2400
- Weather, 438, 737, 740, 742, 747  
 apps, 1255  
 information, 1603, 1605–1607
- Weather Research and Forecasting (WRF), 2472–2475, 2477, 2478, 2480, 2639–2641
- Weather variability  
 on economic growth, 954  
 effects of, 956  
 impact of, 950  
 in Kenya, 960  
 and sectoral output, 956, 958
- Weather variation, 568, 569  
 environment and agriculture, in Nigeria, 569–570
- West Africa  
 Benin, 199  
 cattle farmers' perception of climate change indicators, 204–205  
 climate change indicators, 202  
 climatic zones, 199  
 data collection, 201  
 socio-demographic characteristics of the cattle farmers, 203
- West Africa Coastal Areas Management Program (WACA), 2237, 2238
- West African Monsoon (WAM), 1519, 1521
- West African monsoon (WAM) rainfall, global warming datasets, 2474  
 model domain and numerical experiment setup, 2472–2474  
 precipitation characteristics, 2477–2481  
 temperature characteristics, 2475–2477

- West African Regional Fisheries Program (WARFP), 2225
- Western Cape Water Supply System (WCWSS), 2322
- Western science, 1755, 1756
- Wetland, 824
  - communities, 1228
  - farming, 407
  - of sub-Saharan Africa, 1244
- Wildlife protected areas (WPAs), 662
- WIMEA-ICT, 1118–1119
- Wind divergence analysis, 1138–1140
- Wind energy, 1961
- Windhoek, 2324
- Wind speeds, 1961
- Wind vector, 1138–1144, 1149–1151
- Wireless sensor network, 1739
- Women, 2620, 2622
- Women empowerment, 2057
- Women farmers, 1814
- Women's roles, 1814
- Wood charcoal, 1301–1302
- Woodlot/plantation, 1724, 1728
- World Bank (WB), 36
- World Bank Climate Change portal, 956
- World Climate Conference (WCC), 2449
- World Development Indicators (WDI), 1792
- World Meteorological Organization (WMO), 132, 1614, 1616, 1622
- World Politics Review, 1113
- World Research and Climate program (WRCP), 1614
- World Resources Institute (WRI), 2791
- World Vision Kenya (WVK), 2760
- World Weather Research program (WRWP), 1614
- X**
- Xbee connection to RPi, 1746
- Xbee devices, 1743
- Y**
- Yams (*Dioscorea spp.*), 66
- Yield improving bacteria (YIB), 71
- Z**
- Zambezi River, 2327
- Zambia
  - available suitable areas, 923, 924
  - geographical description, 903–904
  - geographical solar energy potential model, 919
  - potential site and electricity generation potential, 921–942
  - potential site identification and mapping, 907–921
  - solar photovoltaic power plant, 904–907
  - solar PV technical power potential model, 919–920
  - theoretical solar energy potential model, 918–919
- Zambia, climate change and sustainable development
  - agricultural risk, 2031–2032
  - culturally-and policy-driven practices, 2035
  - cumulative barriers and positive feedback loops, 2036–2037
  - cumulative risks and positive feedback loops, 2033
  - environmental change risk, 2032–2033
  - human health risk, 2031
  - inadequate infrastructure, 2035
  - infrastructure risk, 2030
  - land degradation, high rates of, 2034
  - livelihood and economic diversification, 2038–2039
  - maladaptation potential, 2037–2038
  - persistent inequalities, 2036
  - poor livelihood and economic diversification, 2033–2034
  - socio-economic risk, 2030–2031
  - technical and technological capacities, low levels of, 2034–2035
  - weak policy implementation, 2035–2036
- Zanzibar, 5
- Zero tillage, 73
- ZigBee protocol, 1740
- Zimbabwe
  - adaptation strategies, 643–644
  - agricultural production methods, 187
  - agro-ecological regions and potential land use, 183
  - availability of institutions, 2419
  - availability of technologies, 2419
  - barriers for climate change management in rural communities, 2420–2427
  - CIMMYT researchers in, 228
  - climate change, 227
  - climate change and vulnerability, 641–642
  - climate change effect in, 583
  - climate change management at local level, 2412–2416
  - climate change management at national level, 2411–2412
  - cotton production under climate change, 189
  - cotton varieties on branch number, 192

Zimbabwe (*cont.*)

crop genetic diversity and climate change, 185–186  
 CSA in, 227  
 economic resources, 2417  
 equity, 2418  
 gender inequalities, 2424  
 goat breeds in, 648  
 inadequate extension support, 2425–2426  
 inadequate information about the climate change, 2421–2423  
 indicators of adaptive capacity to climate change, 2416–2419  
 in-field moisture harvesting, 188  
 infrastructure availability, 2419  
 lack of institutions that support adaptation, 2423–2424  
 M577, 193  
 M579, 193  
 maize in, 228  
 maize production zones, 184  
 materials and methodology for study, 644–645  
 Matobo district in (*see* Matobo)  
 mulch ripping, 189  
 outbreak of health emergencies, 2426–2427  
 planting basins, 188  
 sectorial vulnerabilities, 185  
 smallholder faming in, 584–586  
 social capital, 2418

soil water content, 190  
 status of cotton, 186  
 stochastic frontier models, 231  
 tied ridges, 188  
 training and awareness, 2417  
 water harvesting on soil moisture content, 189  
 Zvishavane district in (*see* Zvishavane)

Zinc solubilization assays, 1472

Zvishavane

barriers to small grain production, 591–594  
 challenge of quela birds, 592–593  
 characteristics and impact of small grain production on climate change adaptation, 589–591  
 farmers' lack of knowledge, 593  
 farmers' perceptions on climate change in, 586–588  
 food preferences, 594  
 interventions to overcome barriers to small grains adoption, 595  
 labor intensiveness, 592  
 lack of inputs, 591–592  
 lack of markets, 593  
 lower productivity of small grains, 593  
 low extension services and government support, 594  
 smallholder solutions for climate change, 588–589