

Chapter 6

John of Glogów



Peter Barker

Abstract John of Glogów taught at Kraków from 1468 until his death. He wrote on grammar, logic, medicine and especially astronomy, including a commentary on Johannes de Sacrobosco's *Sphaera* (1506). An unusual feature of his Sacrobosco commentary is the extended use of the three-dimensional orb models popularized in Peurbach's *Theoricae novae planetarum* (Nuremberg 1474) and also used by Glogów's colleague Albert of Brudzewo. To situate Glogów's work, I describe the development of celestial orbs in astronomy by Islamicate followers of Ptolemy and their European reception. Early modern Europeans debated the physical reality of eccentrics, epicycles, and the corresponding orbs with the followers of Averroes. After reviewing Glogów's criticisms of Sacrobosco, I conclude that he clearly sides with Ptolemy, Peurbach and Brudzewo against Averroes. His work shows that astronomers after Peurbach attributed physical reality to their theories, and claimed increasing autonomy for mathematical sciences against physics.

1 Introduction

In 1506 John of Glogów (Jan Głogowczyk, Johannes Glogoviensis, ca. 1445–1507) completed a commentary on the *Sphaera* of Johannes de Sacrobosco (died ca. 1256). Glogów's commentary was printed at Kraków, reprinted there in 1513, and again in Strasbourg in 1518. His commentary was typical of many new works on Sacrobosco written during this period. Rather than simply presenting and explaining Sacrobosco's text, fifteenth and sixteenth century commentaries frequently presented new material, as Kathleen Crowther has recently shown in detail (Crowther et al. 2015). In the case of Glogów, the new material was the system of celestial orbs that had first appeared in print in Georg von Peurbach's (1423–1461) *Theoricae*

P. Barker (✉)
University of Oklahoma, Norman, OK, USA
e-mail: barkerp@ou.edu

© The Author(s) 2020
M. Valleriani (ed.), *De sphaera of Johannes de Sacrobosco in the Early Modern Period*, https://doi.org/10.1007/978-3-030-30833-9_6

novae planetarum (Nuremberg, 1474).¹ As Robert Westman points out, the term ‘*theorica*’ should be read in contrast to the term ‘*practica*’ (Westman 2011, 40–43), which correspond roughly to the modern ‘theory’ versus ‘practice’ or ‘application.’ For the science of the stars, astrology formed the *practica*, in contrast to the astronomy presented in the *theorica*. Both the *Sphaera* of Sacrobosco and its commentaries fall on the astronomy side of this divide, although, in the case of Glogów he clearly indicates its connection to astrology. The term ‘*practica*’ was also used for a genre of astrological prognostications, including most importantly the annual prognostications drawn up for a particular place or nation by German speaking astrologers. Glogów contributed a large number of items to this genre (Glogów 1478–1479, 1479–1480, 1480–1481, 1499–1500, 1501–1502, 1502–1503). Indeed, for most Renaissance scholars, it would be fair to say that their main motive for contributing to astronomy was to support astrology, and this connection appears in the work of both Glogów and his student and colleague Albert of Brudzewo (ca. 1445–1495).

Peurbach’s book reignited a long running dispute in the Latin West between followers of the Alexandrian astronomer Claudius Ptolemy (ca. 100–ca. 160) and followers of the Iberian philosopher Averroes (1126–1198). Glogów took a clear position on one side of this dispute in his commentary. Followers of Ptolemy used physical orbs representing eccentrics and epicycles to produce the motions described mathematically in Ptolemy’s *Almagest*. Followers of the Iberian philosopher insisted that all celestial orbs must be centered on the earth. After a brief biography of Glogów, I will describe the historical development of the orb models used in Peurbach’s *Theorica* and Glogów’s commentary on Sacrobosco. I will go on to examine the latter book’s significance in the wider context of the dispute with the Averroists, and finally consider how the celestial orbs appear in Glogów’s book, comparing his presentation with the text of Sacrobosco that he comments on.

Glogów was educated at the Jagiellonian University of Kraków from 1462–1468 and subsequently became an influential teacher there until his death in 1507 (Goddu 2010, 27). His nearly 40 years of teaching overlapped the career of his student Albert of Brudzewo, as well as Nicolaus Copernicus’s (1491–1495) early education (Barker 2013a, b; Malpangotto 2016; Sylla 2017). Glogów’s duties are known in detail for 1487–1506. Between 1487 and 1500 he taught logic and grammar, with the addition of *De anima* in 1491, *De caelo* in 1493 and Aristotelian physics in 1499 (Szczegola 1967, 23–24; Goddu 2010, 31). He spent the academic year 1497–1498 at the University of Vienna (Goddu 2010, 36). He seems to have taught Sacrobosco only in 1506, the year his commentary was printed.

¹As I am not satisfied with any of the terms that might be used translate it into modern English, in the present paper I will retain the contemporary term *theorica* (pl. *theoricae*) as far as possible, for a variety of uses. A *theorica* (small ‘t’) is a model offering a basis for calculating planetary positions against the fixed stars, expressed as angles from a fixed line of reference. The *theoricae* for individual planets may be quite separate; the appearance of particular features in one should lead to no expectation that a similar feature will appear in adjacent planets, or as universal feature of the *theoricae* of all planets. Second, a *Theorica* (capital ‘T’) is a book presenting *theoricae*. The most important instances are the anonymous traditional *Theorica planetarum* often attributed to (Gerard of Cremona 1472), and Georg Peurbach’s *Theoricae novae planetarum* (Peurbach 1474).

John of Glogów was what is now called an “early adopter” of the new technology of printing. The first publications I have found were in astronomy and astrology, beginning with a description of solar and lunar eclipses, including a *practica*, a yearly list of astrological prognostications, covering the weather, health and politics, for the year 1479. This, and several later *practica* by Glogów (e.g. for the years 1480, 1481), were published by Marcus Brandis (flourished after 1473; otherwise known as “the printer of Isidoru’s *Soliloquia*”), at Merseburg in Saxony, which lies south of Halle and west of Leipzig. Shortly before 1500 Glogów established a working relationship with Jan Haller (ca. 1467–1525), who became the most important bookseller and publisher in Kraków itself, and began to publish books on many of the subjects fundamental to university education for early sixteenth century students (Benzing 1966). Glogów’s book on Aristotle’s (348–322 BCE) *Posterior analytics* as treated by Johannes Versoris (died ca. 1485) was printed by Wolfgang Stöckel (died ca. 1539) in Leipzig, for Haller, in 1499. Glogów’s commentary on the second of four parts of the versified Latin grammar of Alexander de Villa Dei (1170–1250), and his books on Donatus’s *Ars minor*, and Peter of Spain’s *Parva logicalia* were printed in the same way in 1500. Haller was also credited as publisher of the book on the *Posterior analytics* in 1501, when it was republished by Hartfelder in Metz. Haller himself, in Kraków, produced a new version of the Donatus in 1503, and a new work on Porphyry’s *Isagoge* plus another edition of Villa Dei’s grammar in 1504. In 1506–1507 Haller published another of Glogów’s prognostications, which like the 1502 version gave times for blood-letting and other medical procedures. In 1507, the year of Glogów’s death, Haller published another new work, the *Computus Chiometralis*, with a revised edition in 1510. In fact the Haller firm continued to publish Glogów’s books after it absorbed the press of Florian Ungler (died 1536), and there is no evidence that Glogów used any other publisher in Kraków. Hence, although the 1506 *Introductorium compendiosum in Tractatum Spere* identifies only its place of publication, which is Kraków, we may be fairly certain that Haller was the publisher. And the case is strengthened by the second edition in 1513, which was printed by Ungler for Haller. Johann Knoblauch (died 1528) in Strasbourg began to republish the books on Donatus, Peter of Spain, and other topics in the humanities, in 1515. He apparently published the third edition of Glogów’s commentary on Sacrobosco in 1518 (again reasoning from the city, and the printer’s prior activity).

Szczegola, Glogów’s modern biographer, claims that his contributions to the science of the stars included “between 50 and 60 titles” published at Leipzig, Merseburg, and Kraków, including many *practica*, the *Computus Chiometralis* (Glogów 1507, 1511a, b), the posthumous *Introductorium Astronomie in Ephemerides* (Glogów 1514a, b), which Szczegola calls an *Introductorium cosmographiae*, a *Summa astrologiae* (perhaps the *Tractatus preclarissimus in iudiciis astrorum*, Glogów 1514b) and a *Defensio astrologiae* (“Persuasio brevis quomodo astrologiae studium religioni christianae non est adversus”/“A brief argument on how the study of astrology is not contrary to the Christian religion”), which I have been unable to locate, as well as the Sacrobosco commentary (Szczegola 1967, 72–73, 78–90).

2 Astronomical Orbs from Ptolemy to Peuerbach

Glogów's commentary on Sacrobosco takes a position in a dispute that goes back to the origins of astronomy as an exact science in the West. The very earliest mathematical models of planetary motion were developed by Aristotle's contemporary Eudoxus of Cnidos (died 347 BCE), who devised sets of earth centered circles, rotating about their diameters, and suspended one inside another so that a planet carried on the innermost circle accrued all the motions of the circles supporting it. Eudoxus seems to have provided only the bare mathematical model. Aristotle, however, physicalized it, by replacing each of Eudoxus's original circles with an orb of the same diameter and rotating on the same axis. However, it was already accepted that some planets were further away than others. Saturn, for example, was assumed to be the outermost planet because it took more than 30 years to return to the same point relative to the stars. Jupiter was inside it, with a period of about 12 years. But the orbs carrying Jupiter could not simply be attached to the innermost orb of Saturn, without unintentionally transmitting all the motions of Saturn to the orbs of Jupiter. To prevent this, Aristotle inserted counteracting orbs between the sets moving each planet, giving a grand total of 55 spheres for all the planets (North 2008, 73–84).

In addition to moving against the background of fixed stars, the outer planets Mars, Jupiter and Saturn also vary in brightness. The most obvious explanation for this was that they changed their distance from the earth, something that could not happen in Eudoxus's and Aristotle's constructions, where all motions were centered on the earth and strictly concentric. By the time Claudius Ptolemy synthesized and improved contemporary astronomy, earth centered models had been replaced by models using a large circle (the carrying circle or deferent) to carry the center of a small circle (called the epicycle). The center of the deferent was located at or near the center of the earth, but displacing its center, and especially placing the planet on the smaller epicycle it carried, allowed planets to vary their distances from the center of the cosmos. A carrying circle with a displaced center was termed an eccentric, thus the basic mathematical tools in astronomy at the time of Ptolemy, eccentrics and epicycles, both used circles with centers that were not the center of the earth. To this, Ptolemy added his own unique contribution—the equant—probably in an attempt to align the directions and durations of planets' reverse motions (Evans 1998, 384–92; North 2008, 114–18). Taking a diameter of the deferent through the geometrical center of the deferent itself and the center of the earth, the equant is a point on this line that is the same distance away as the earth but on the opposite side of the deferent center. Ptolemy made this point the center of uniform rotation for the epicycle, greatly improving empirical accuracy, but at a cost in physical terms.

In his major book on astronomy, now known as the *Almagest*, Ptolemy, like Eudoxus, provided only mathematical models (Toomer 1998). Taking the same step that Aristotle had for Eudoxus, Ptolemy attempted to provide a physical basis for these models in a subsequent book, now known as the *Planetary Hypotheses* (Goldstein 1967). Basically he showed that eccentric and epicycle circles could be generated by sets of orbs—the partial orbs printed for the first time in Johannes

Regiomontanus' (1436–1476) version of Peurbach 1474, and illustrated in the images later in this paper taken from Glogow's commentary on Sacrobosco. However, there are two complications to this simple story. First, the circles generated by rotating orbs are the traces of points, usually on the equator of the orb, which itself rotates about a diameter corresponding to the poles, each 90 degrees from the equator. This diameter passes through the geometrical center of the orb, perpendicular to the plane of the equator. But the equant is not at the center of the eccentric circle or the corresponding orb, so the equant motion cannot be represented by the natural rotation of an orb, about an axis through its geometrical center. In fact, it is not clear that the motion about the equant point has any physical significance for an orb with a different geometrical center (Andersen et al. 2006, 117–46). These difficulties were unresolved by Ptolemy but assumed a special significance as astronomy developed in the Islamicate world.

As in the case of Ptolemy, the development of astronomy in the Islamicate world was motivated by the needs of astrology. Initially, Islamicate scholars drew on sources from India, Persia, Byzantium, and, in translation, the earlier Greek tradition (Saliba 2007, Chaps 1–3). From Ptolemy they received both his works on astronomy and astrology, the *Almagest*, the *Planetary Hypotheses*, and the *Tetrabiblos*. Between the reign of Caliph al-Ma'mun (reigned 813–833) and the career of Abū Sa'īd Aḥmad ibn Muḥammad ibn 'Abd al-Jalīl al-Sijzī (ca. 945–ca. 1020), Ptolemy's works became the paradigm defining all Islamicate astronomy (Sayili 1960, 79–80; Brummelen and Glen 2007). Sijzī wrote the first Ptolemaic introduction to astronomy, or *hay'a*, without using partial orb models like those found in later in Peurbach and Glogow. But by this time advanced practitioners of astronomy had begun to recognize the problem posed for orb models by the equant. Ibn al-Haytham (965–1040), who spent the latter part of his life in Cairo, wrote a comprehensive critique of Ptolemy's models, pointing out, among others, the problem with the equant (Voss 1985). Ibn al-Haytham's critique had two outcomes.

After more than a century of uncertainty Naṣīr al-Dīn al-Ṭūsī (1201–1274) and his colleagues at the Marāgha observatory in northern Persia provided a variety of solutions to the problems raised by Ibn al-Haytham (Ragep 1993, 50, Table 1, for a list of the problems). One major method, developed by Ṭūsī himself, used two circular motions to produce reciprocating motion on a straight line.² Replacing the circles by orbs gave a three dimensional device that, when added to the partial orbs representing eccentrics and epicycles, yielded results comparable to the equant, but used only orbs that rotated about their own diameters. A second device, developed by Ṭūsī's colleague Mu'ayyad al-Dīn al-'Urḍī (died ca. 1266), eliminated the equant by redefining the eccentricity of the deferent circle, again allowing an orb model with components that rotated about diameters (Schmidl 2007). Both of these methods later appeared (without attribution) in the work of Copernicus in Poland (Swerdlow 1973; Swerdlow and Neugebauer 1984). The methods introduced by Ṭūsī's and his colleagues rapidly became the new paradigm in Islamicate astronomy

²For Ṭūsī's method, see the animations at: <https://people.sc.fsu.edu/~dduke/models>. Accessed June 2019.

East of Cairo. This change has been described as a scientific revolution (Saliba 1987). Although Ptolemy was still used as a source book, advanced treatments of astronomy all employed devices that avoided the equant and all gave orb models based on these devices that had no objectionable features. Work in this new tradition continued as late as the eighteenth century, when the astronomer of Mughal prince-practitioner Sawai Jai Singh (reigned 1699–1743) wrote a commentary on the section the Ṭūsī's book where he introduced the device that replaced the equant (Sharma 1995; Kusuba and Pingree 2002). Although this new paradigm reached the Latin West in various ways, it never became dominant (Barker and Heidarzadeh 2016; Ragep 2017). Instead, the astronomical tradition in Europe modeled itself on Islamic astronomy before Ṭūsī. The most important advanced text remained Ptolemy's *Almagest*. The two most common introductory book's Sacrobosco's *Sphaera* and the *Theorica planetarum*, both presented themselves as introductions to the *Almagest*. None of these books used orb models.³ Although the orb models that were now a standard feature of Islamicate astronomy did appear in Europe, their supporters had to counter criticisms directed at the very legitimacy of epicycles and eccentrics. These criticisms, made by Averroes (Ibn Rushd) were a second consequence of Ibn al-Haytham's work, and they had much greater influence in Western Europe than they did in the Islamicate world.

3 The Dispute with the Averroists in Europe

Averroes's primary criticisms of Ptolemaic astronomy depended on the alleged physical impossibility of eccentrics and epicycles, according to a strict reading of Aristotle's physics. Eccentrics and epicycles, whether circles or orbs, rotated about centers that were not the center of the earth. But according to Averroes's reading of Aristotle, all celestial motion had to be centered on the earth. Hence, according to Averroes, eccentrics and epicycles were physically impossible even if they produced predictions in accord with observation. Averroes's contemporary Alpetragius (al-Biṭrūjī, flourished ca. 1150–1200) attempted to revive Eudoxus's earth-centered orbs as a technical alternative to Ptolemaic models, and his work was well known in Europe (Goldstein 1971). Attempts to develop a strictly geocentric astronomy continued in the Andalusian Jewish community into the early modern period, and a Jewish scholar was also responsible for a new translation of Alpetragius as late as 1531 (Morrison 2016; Calonymus 1531). Despite these efforts no real alternative to Ptolemaic astronomy emerged in Europe, and Averroes's criticisms and Alpetragius's theories were ignored east of Cairo, probably for several reasons. First, as in Europe, Islamicate followers of Ṭūsī and his colleagues recognized that the Averroists failed to provide any mean of calculating planetary positions. Ptolemaic astronomy in

³During the discussion at the conference from which this book derives, Angela Axworthy suggested that the ontological discussion of spheres and substances in Sacrobosco Books I-III might predispose students to 'ontologize' the circles in Book IV.

Europe, and Ptolemaic astronomy as modified by Tūsī elsewhere, remained the only practical method of making predictions. Second, in the Eastern Islamicate world annular eclipses were a generally recognized phenomenon. Usually, during a total eclipse, the moon completely covers the sun. However sometimes, when the center of the moon coincides with the center of the sun, the moon does not completely cover the sun, but leaves a bright ring (Latin: *annulus*) all around the moon's edge. Islamicate astronomers agreed that this phenomenon demonstrated that the moon was further from the earth during an annular eclipse. Variation of distance ruled out the possibility that the moon was carried by an orb concentric to the earth, and seemed to require eccentrics and epicycles.

Almost from the time of their appearance, Averroes's commentaries on Aristotle's *De caelo* created a school of philosophers writing in Latin who supported his strict geocentrism and attacked Ptolemaic eccentrics and epicycles as physically impossible, which, by default, supported an astronomy using only earth-centered orbs. While most supporters of Averroes were people whose main professional interest was philosophy or theology, they included people who worked in technical astronomy, for example, Richard of Wallingford (ca. 1292–1336) (North 2008, 258–62). This is surprising, as Europeans also recognized that no strictly geocentric astronomer, including Alpetragius, was ever able to convert their physical models into algorithms that would accurately predict the positions of celestial bodies. A younger contemporary of Glogów and Brudzewo described the situation in a book that appeared in 1543:

Some use only earth-centered circles, others eccentrics and epicycles, but they do not fully achieve what they seek. For although those who rely on earth-centered circles demonstrated that some non-uniform motions could be compounded from them, they were unable to establish anything certain that indisputably corresponded to the phenomena from this.⁴

Although there may have been earlier Latin exponents of partial orbs, who have not yet come to light, a convenient starting point to understand the dispute with the Averroists in Europe is the work of Roger Bacon (ca. 1214–1294), who was a contemporary of both Sacrobosco and the author of the *Theorica planetarum*. In his *Opus tertium*, Bacon presented the partial orb construction later used in the *Theoricae novae*, although Bacon himself rejected such devices in favor of concentric spheres (Grant 1996, 278ff; Lerner 2008, I:115). Bacon testifies to one of the accidents of history. Although Ptolemy's *Almagest* was available in Europe by the twelfth century, the *Planetary Hypotheses* was never available in its entirety (Goldstein 1967). Consequently, people like Roger Bacon presented the orb models as the *ymaginatio modernorum*, something thought up by contemporaries, and specifically their Islamicate contemporaries. In addition to the attacks by Averroes, the seeming lack of endorsement by Ptolemy further undermined the status of orb

⁴(Copernicus 1543, iii V): “Alii namque circulis homocentris solum, alii eccentricis et epicyclis, quibus tamen quaesita ad plenum no asequuntur. Nam qui homocentris consisti sunt, etsi motus aliquos diversos ex eis componi posse demonstraverint, nihil tamen certi, quod nimirum phaenomenis responderet, inde statuere potuerunt.”

models in Europe. The result was a controversy that lasted until the time of Galileo Galilei (1564–1642) (Andersen et al. 2006, 117–29).

While William of Auvergne (died 1249) defended the Averroist concentric approach, Thomas Aquinas (1225–1274), and John of Jandun (died 1328), who both taught at Paris, denied or qualified the orbs' reality (Grant 1996, 280–81 and n. 34). However the partial orbs, much as they appear in Peurbach, were presented at length by Bernard of Verdun. Bernard's dates are uncertain, but his book was probably written after Bacon's work and towards the end of the twelfth century (Bernard of Verdun, ed. Hartmann 1961). Lerner notes Duhem's claim that Bernard had many supporters in Paris from the end of the thirteenth century into the fourteenth century (Lerner 2008, I:117–18, text to n. 44). Another Parisian, Henry of Langenstein (also known as Henry of Hesse, ca. 1325–1397), who opposed epicycles and eccentrics, went on to teach at the University of Vienna, which was the academic home of Peurbach and Regiomontanus (Kren 1968, 269–81; Lerner 2008, I:114). So Peurbach's lectures ending in 1454, which became the basis for the *Theoricae novae* both in manuscript and in print, may be as seen as a response to Averroist denials of eccentrics and epicycles that were comparatively recent and local. In the interval between Langenstein and Peurbach, Pierre d'Ailly (ca. 1350–1420) presented the partial orbs with particular clarity, supporting their existence as real parts of the heavens, in a set of questions on the *Sphaera* that would be frequently republished after the advent of printing (Ciruellus 1498; Grant 1996, 281–83; Shank 2009) (Chap. 3). Another intermediary was Prosdocimo de Beldomandi (ca. 1380–1428), whose commentary on Sacrobosco circulated in manuscript and was printed in 1531 (Prosdocimus de Beldomando 1531; Markowski, 1981; Axworthy 2016) (Chap. 8).

The early years of printing supported a wave of new initiatives to improve classic texts and to supply university students, one of the few captive markets for the new technology (Crowther and Barker 2013). Peurbach's *Theoricae novae* was printed no later than 1474 at Nuremberg by his student Regiomontanus as part of a project to provide printed editions of works in mathematics and astronomy (Zinner 1990, 22; Aiton 1987). The original *theorica*, which now became known as the *theorica veteres*, was also printed in 1472, in Ferrara, attributed to Gerard of Cremona (ca. 1114–1187), and in Padua, attributed to Gerard of Sabbioneta, showing the uncertainty about its author. The original *Theorica* was rapidly supplanted by the *Theoricae novae* and its commentaries. The older *theorica* was printed only eight times between 1467 and 1531, while the *Theoricae novae* and its commentaries went into hundreds of editions from 1474 through the mid seventeenth century (Aiton 1987, 7, n. 8; Barker 2011, 11–12). However, the opportunities presented by printing were also used by a new generation of Averroists, especially in Italy. New editions of both Aristotle's and Averroes's work appeared beginning in 1472–1474 (exactly the same period as the printing of Peurbach's *Theoricae novae* in Nuremberg), and including Aristotle's work with Averroes's commentaries appended to or surrounding them (Hasse 2016, 78–79, 347–54). Consequently Averroes's objections to eccentrics and epicycles reached a new audience and were articulated in new ways.

Among the most influential Averroists of the late fifteenth century were Agostino Nifo (ca. 1470–ca. 1540) and Alessandro Achillini (1463–1512). Nifo took the Averroist side in debates with Francesco de Capuano (flourished 1496–1531), who was writing his own commentaries on Sacrobosco and Peurbach (Barker 2011, 14–17) (Chap. 4). The latter contained the most detailed rebuttal of Averroes that I have found in the *theorica* and *sphaera* literature, which may go some way to explaining why it was printed at least seven times between 1496 and 1531, despite its size (Aiton 1987, 7). At the same time that Nifo and Capuanus were at work, Achillini composed a book on the nature of the celestial orbs, using Averroes’s arguments in the technical vocabulary of Peurbach to attack the celestial orbs (Barker 2011, 17). Nifo drew attention to the continuing importance of the objections to eccentrics and epicycles by adding figures in his edition of Averroes commentary on Aristotle’s *Metaphysics* (Nifo 1496, Images: 117r, Comment 45).⁵

This brief history of the dispute between the followers of Averroes and the followers of Ptolemy, and Peurbach, shows that Glogów’s Sacrobosco commentary was composed, and printed, in the context of the dispute over the structure of the celestial orbs. Both parties accepted the reality of total orbs—the orbs concentric to the earth corresponding to the zones of each planet in turn. The dispute was about the inner structure of these orbs. The Averroists insisted that these orbs could only be divided, like the layers of an onion, into other concentric orbs. The followers of Peurbach divided them into spherical epicycles carried by uniform eccentric orbs, enclosed by non-uniform complementary orbs. Glogów asserts the reality of this alternative configuration of the heavens.

Glogów’s commentary was composed for the use of students learning astronomy at the University of Kraków. Several other major figures taught astronomy there in the same period. The most important was Albert of Brudzewo who completed a parallel commentary, not on Sacrobosco, but on the *Theorica novae planetarum* itself, no later than 1482 (Barker 2013a). Brudzewo’s work is one of the most significant pieces of evidence for the reception of Peurbach’s ideas, and the first full length commentary written after the appearance of the *Theoricae novae* itself. It begins with criticisms of Averroes and then presents Peurbach’s ideas in a positive light, asserting the physical reality of the orbs. So Brudzewo not only sides with the followers of Ptolemy by supporting Peurbach, he explicitly attacks the opposing camp. But Glogów’s commentary on Sacrobosco is not quite the first to advocate Peurbach’s orbs. An important antecedent is the version by Pedro Ciruelo (1470–1554) that appeared in Paris in 1498 (Barker 2011, 15–16) (Chap. 3). Glogów too was taking a position that was pro-Ptolemy and anti-Averroes, by introducing Peurbach’s orbs in a commentary on Sacrobosco. His long association with Kraków, and with Brudzewo, suggests that he would be explicitly aware of the Ptolemaist-Averroist dispute.

⁵This dispute continued well after the death of Glogów. See, for example (Chap. 8).

4 Sacrobosco on the Celestial Circles, and Glogów on the Celestial Orbs

In the fourth chapter, or part, of the *Tractatus de sphaera*, Sacrobosco gives a very brief introduction to the mathematical tools used by Claudius Ptolemy in the *Almagest*, and all subsequent astronomers, to describe the motions of the sun, moon and planets. Sacrobosco's exposition is barely more than a list the main concepts, all of which are presented as circles of various types. It takes up less than 400 words in Latin and a mere four paragraphs in the English translation by Thorndike (Thorndike 1949, 113–15, 140–41). In his commentary, Glogów greatly extends Sacrobosco's presentation, arguing that Sacrobosco is wrong about several fundamental issues. He insists that the circles mentioned by Sacrobosco are not real things, but that the orbs introduced by Peurbach are, implicitly assuming that any astronomical model must be (in principle) adequate to explain the *causes* of planetary motion. As circles and other mathematical objects have no causal powers they cannot be what moves the planets. In their place, Glogów introduces the same sets of celestial orbs that students would encounter in Peurbach's book and Brudzewo's *Little Commentary* on it (Barker 2013a), and he provides his own illustrations. As the study of the *Sphaera* always preceded study of the *Theorica*, we must assume that for students at Kraków, the exposition in Glogów's commentary on the *Sphaera* was intended to be their first introduction to these matters.

Sacrobosco begins with the model for the sun, which in Ptolemy consists of a single eccentric circle. Sacrobosco defines the term 'eccentric' and also the furthest and nearest points of the circle from the center of the world, which are termed '*auxes*' in Latin. He goes on to describe two motions of the sun: its daily motion of about one degree and its precessional motion (although he does not call it that) of one degree in 100 years. Sacrobosco fails to note that the first motion is recurrent while the second is cumulative, or to give any real explanation for the second motion. But about the first he says:

It should be noted that the sun has a single circle in which it is moved in the plane of the ecliptic, and it is eccentric.⁶

To this Glogów replies:

It should be understood, therefore, that when the author [Sacrobosco] says in the text that the sun has a single orb or circle in which it is moved, this comment of the author should be understood to be about the total orb. For each planet has at least three orbs. The total orb is constituted by the three partial orbs. Hence in this way [*unde sicut*] the author of the *Theoricae* [Peurbach] says "The sun has three orbs...."⁷

⁶(Glogów 1506, [I v R]): "Notandum q[uam] sol habet unicum circulum p[er] que[m]moveretur in sup[er]ficie linee ecliptice et est eccentricus." Although (Thorndike 1949, 113 n. 3), has two sources that include 'linee,' he omits it, as do I in translating his line.

⁷(Glogów 1506, [I v R–V]): "Scie[n]du[m] igit[ur] qu[od] autor in textu dicit qu[am] sol hab[et] unicu[m] orbem vel circulu[m] i[n] quo movet[ur] hoc dictu[m] auctoris intellige[n]du[m] e[st] de orbe totali. Quilib[et] enim planeta hab[et] tres [I v V] orbis ad min[us]: ex quib[us] trib[us] partialib[us] co[n]stituit[ur]: et e[st] orbis totalis un[de] sic[ut] i[n]q[ui]t autor theorica[rum] Sol

Fig. 6.1 *Theorica* figure for the sun. From (Glogów 1506, fol. [1 v V]). Bavarian State Library, Res/4 A.gr.b. 430#Beibd.2. [urn:nbn:de:bvb:12-bsb10198086-2](http://nbn:de:bvb:12-bsb10198086-2)



Glogów goes on to quote the first paragraphs of Peurbach’s *Theoricae novae*, explaining that the body of the sun is fixed in an eccentric orb and moved by it in its annual motion, while two complementary orbs, that together make the three-orb system concentric to the center of the world, also rotate slowly and keeping pace with each other so that they shift the direction of the *auxes* (nearest and farthest points) of the eccentric. He illustrates the partial orbs with (Fig. 6.1) which is a redrawn version of the figure on the first page of Peurbach’s *Theoricae* (Fig. 6.2). It is sometimes difficult to decipher these images. The figures show a cross-section through the set of three orbs that move the sun. It is perhaps easier to recognize the various parts if the entire image is rotated, and the parts separated, making their three-dimensionality more apparent (Fig. 6.3). Note the correlation between colors of the parts in the image from Peurbach (Fig. 6.2) and the rotated version (Fig. 6.3). Considered as three-dimensional objects, the image shows three hemispheres, or more correctly, hemi-orbs. One of these (white) is a conventional orb with both surfaces centered on the same point, and hence a uniform thickness. The remaining two objects, or complementary orbs, are colored uniformly. Because their spherical surfaces have different centers they are not uniform in thickness, giving them their characteristic ‘crescent moon’ appearance when shown in cross section (Figs. 6.1 and 6.2). Looking at (Fig. 6.3) you should be able to see that if the existing

habet tres orbes...;” (Glogów 1518, K ii R): “Sciendum igitur qu[od] autor in textu dicit qu[am] sol habet unicum orbem vel circulus in quo movetur, hoc dictum auctoris intelligendum est de orbe totali. Quilibet enim planeta habet tres orbes ad minus: ex quibus tribus partialibus constituitur: et est orbis totalis. Unde sicut inquit autor theoricarum: Sol habet tres orbes...”

Fig. 6.2 *Theorica* figure for the sun. From (Sacrobosco et al. 1482, fol. e 1 V). Bavarian State Library, 4 Inc.c.a. 256, [urn:nbn:de:bvb:12-bsb00054605-7](http://nbn:de:bvb:12-bsb00054605-7)

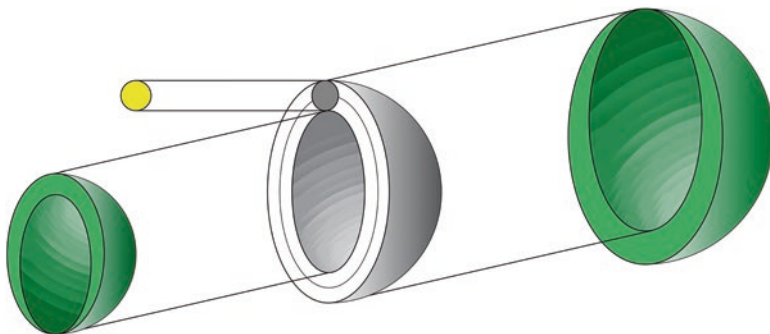
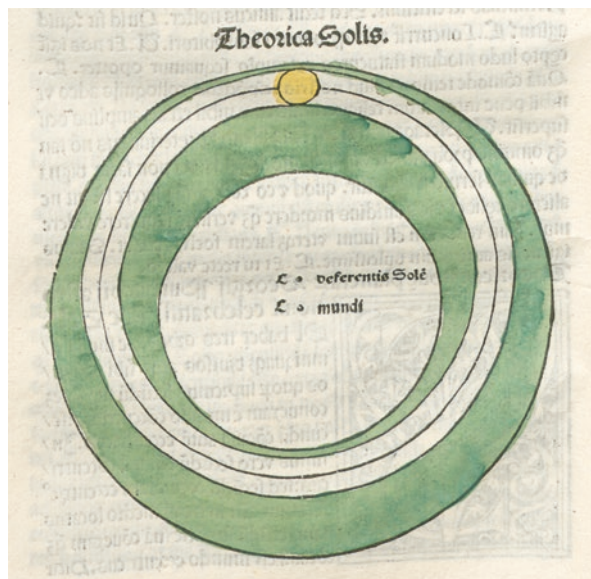

Fig. 6.3 Peuerbach *theorica* figure for the sun, rotated and separated. <http://astronomy.voxcanis.com/>

hemi-orbs are reflected in the plane of the original figure, they would become complete orbs, that is solid objects bounded by two spherical surfaces. The inner white orb carries the body of the sun and rotates, without friction, between the colored complementary orbs to create the annual motion of the sun. The two complementary orbs rotate so that they always maintain the same relative orientation—the thinnest part of one is always nearest the thickest part of the other—creating the motion of precession by moving the direction of the *auxes* of the white orb.⁸

⁸To see these motions, visit <http://astronomy.voxcanis.com> and scroll down to see the animation. Accessed June 2019.

Looking now at Glogów's figure and comparing it to Peurbach's (Figs. 6.1 and 6.2), we note that the center of the world is indicated at the center of the figure, with the center of the deferent slightly above it. The latter is the geometrical center for the white part of the figure, which is the cross-section of the eccentric orb of uniform thickness carrying the sun. The sun is shown by the small circle touching both edges of the white orb at 12 o'clock. The complementary orbs—shown in black—are not very well drawn. Although the figure clearly conveys the important information that the thickest part of the outer orb is closest to the thinnest part of the inner orb, and *vice versa*, the thinnest parts of both orbs should be much thinner than shown here. In fact the two surfaces of the complementary orbs and the concentric orb should all meet at a point. Note also that a circle has been drawn down the center of the white part of the figure (the cross section of the eccentric orb). This line traces the motion of the center of the sun and corresponds to the eccentric circle that appears in Ptolemy's *Almagest* model and Sacrobosco's description. As we will see, Glogów makes an explicit comparison between this circle and the orbs he is presenting.

Sacrobosco and Peurbach follow the order of Ptolemy and the older *Theorica* in introducing the model for the sun first. In Peurbach's case, however, this is doubly important, because the orb model for the sun forms the basis for the planetary models. In addition to the eccentric circle, the *Almagest* planetary models require an epicycle, a subsidiary circle the center of which is 'carried' by the eccentric circle. In the orb models this is achieved by replacing the body of the sun with a solid sphere, which carries the planet embedded within its outer surface, so that the sphere of the planet's body and the sphere of the epicycle touch internally at a single point. The first application of this construction is to the moon (Fig. 6.4).

Sacrobosco says this about epicycles:

Every planet except the sun has three circles, namely, an equant, deferent, and epicycle.... Also every planet except the sun has an epicycle. An epicycle is a small circle the circumference of which carries the body of the planet and the center of the epicycle is always carried along the circumference of the deferent.⁹

Referring to (Fig. 6.4) and treating the concepts in the reverse of Sacrobosco's order, look first at the three circles at 12 o'clock. The largest of these circles touches each of the complementary spheres at one point (12 o'clock and six o'clock for that circle itself). Imagine that this circle is the circumference of a hemisphere, embedded in the white eccentric orb in the same way that the body of the sun was embedded in the previous model. Now imagine embedding a much smaller spherical planet inside this sphere, so that it touches the surface of the epicycle sphere internally at a single point (for simplicity, say, again, 12 o'clock). Next imagine that the epicycle sphere rotates about its center around an axis that is perpendicular to the

⁹(Glogów 1506, [I vi V]): "Quilibet aute[m] planeta tres habet circulos pr[a]eter solem s[e]c[un]dum equa[n]tem, deferentem et epiculum." (Thorndike 1949, 114) has 'scilicet' for 'secundum'. (Glogów 1506, m ii R): "Quilibet etiam planeta p[rae]ter solem habet epiculum. Est autem epicul[us] circulus parvul[us] p[er] cuius circumferentiam defertur corpus planete et centrum epiculi semper defertur in circumferentia deferentis."

Fig. 6.4 *Theorica* diagram for the moon. From (Glogów 1506, fol. [1 vi V]). Bavarian State Library, 1,550,533 Res/4 A.gr.b. 430#Beibd.2. urn:nbn:de:bvb:12-bsb10198086-2



plane of the image on the paper. Then, as the epicycle sphere rotates, the inner edge of the planet will describe a second circle. This is the smallest of the three circles we are examining. Finally, as the planet is carried around by the epicycle, its center will describe the third circle in the figure, intermediate in size between the larger and smaller ones. This circle will correspond to the epicycle circle in Ptolemy's *Almagest* model, just as the line down the center of the eccentric orb's cross section corresponds to the eccentric deferent circle.

So actually the introduction of epicycles in the orb models is an iterative procedure. The epicycle—formerly the body of the sun—is carried around the center of the cosmos by an eccentric orb the thickness of which is defined by the size of the epicycle, and in so doing, its center traces out the circle drawn down the center of the cross section of the eccentric. Within the epicycle, the planet is carried in an exactly similar way, so that its center traces out its own circle. In principle, no more of the epicycle is required than the depth needed to accommodate the planet. Using only this part of the epicycle sphere would make the orb carrying the planet isomorphic to the orb carrying the epicycle itself. The only real difference is that the larger mechanism (the eccentric orb) cannot be represented by a solid orb, because there needs to be a space inside the eccentric. The inner complementary orb makes this space concentric with the center of the world. In the case of the sun, the orb set for Venus fits inside the inner complementary orb. The orb set for Mercury fits inside the inner complementary orb for Venus, and the orb set for the moon fits inside the inner complementary orb for Mercury. However, there was no practical need for a space in the center of the epicycle orb, so it was usually treated as solid all the way through. The epicycle sphere is used in the orb models for all the planets except the sun, although there are special complications in the cases of the moon and Mercury.

Sacrobosco says several unhelpful things about the moon, trying to ignore the peculiarities of the lunar model and treat all the remaining planets and the moon using the same terms, and, by implication, concepts:

Every planet except the sun has three circles, namely, equant, deferent, and epicycle. The equant of the moon is a circle concentric with the earth and in the plane of the ecliptic. Its deferent is an eccentric circle not in the plane of the ecliptic. Indeed, one of its halves slants toward the north and the other toward the south. Consequently the deferent intersects the equant in two places, and the figure of that intersection is called the “dragon” because it is wide in the middle and narrow toward the ends. That intersection, then, through which the moon is moved from south to north is called the “head of the dragon,” while the other intersection through which it is moved from north to south is called the “tail of the dragon.” The deferent and equant of each planet are equal.¹⁰

There are so many near falsehoods and infelicities in this passage it is hard to know where to begin. The equant is the main mathematical innovation in the *Almagest*, and this is the worst possible way to introduce it to novices. In the *planetary* models Ptolemy was faced with the problem that using an eccentric circle and an epicycle did not produce predictions that fitted observation. By a process that probably compared directions of retrogressions with durations of retrogressions, Ptolemy introduced equant points (Evans 1998, 384–92). The equant point is symmetrically placed at the same distance from the center of the eccentric as the center of the cosmos but on the opposite side. Each planet has one. These points, not the geometrical centers of the deferents, now serve as the centers of uniform rotation for any point on the circumference of the eccentric circle, and especially the point which is the center of the epicycle. However these are *points*, not *circles*. It is true that there is a circle in the moon model which has a somewhat similar function, and that it is sometimes referred to as the moon’s equant. This circle is one of the differences between (Fig. 6.1) and (Fig. 6.4); it is the circle closest to the center of the (Fig. 6.4) that has no corresponding circle in (Fig. 6.1). But this is utterly misleading about the equants that occur in all the other models, which the student will now also expect to be circles.

To make matters worse Sacrobosco goes on to explain the Head and Tail of the Dragon using the equant. As the moon’s path is slanted with respect to the sun’s path across the sky, the moon crosses the sun’s path twice each month. The passage from South to North (or ascending node) is rather grandiloquently called the Head of the Dragon, and the passage from North to South the Tail of the Dragon. These points are important because a total eclipse can only occur when the moon is in one of them. They are usually defined as the intersection points of the plane of the moon’s

¹⁰(Glogów 1506, [I vi V]): “Quilibet aute[m] planeta tres habet circulos pr[a]eter solem s[e] c[un]dam equa[n]tem deferentem et epiculum. Equa[n]s quidem lune est circulus co[n]centricus cum terra et est in sup[er]ficie ecliptice. Eius aute[m] deferens est circulu[s] ece[n]tricus nec est in sup[er]ficie ecliptice immo una eius p[ar]s et mediatas declinat v[er]sus septe[n]trione[m] et alia v[er]sus austrum et intersecat defere[n]s equante[m] in duobus locis. [m i R] Et figura intersectionis appelelatur draco quoniam lata et in medio et angustior versus finem. Intersectio ig[itu]r illa p[er] qua[m] movetur [l]una ab austro versus aquilonem appellatur caput draconis. Reliqua [ver]o intersectio p[er] q[uam] movetur a septe[n]trio[n]e i[n] aust[rorum] d[icitu]r cauda draconis. [m i V] Defere[n]tes quidem et equantes cuius ub[er]m] planete sunt equales.”

Fig. 6.5 Diagram for the Head and Tail of the Dragon. From (Glogów 1506, fol. m [i] V). Bavarian State Library, Res/4 A.gr.b. 430#Beibd.2. [urn:nbn:de:bvb:12-bsb10198086-2](http://nbn:de:bvb:12-bsb10198086-2)

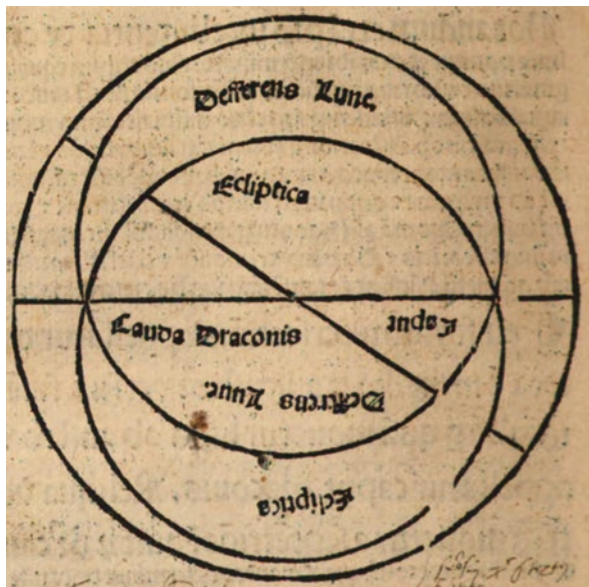

path and the plane of the sun's path (or ecliptic). However Sacrobosco tells us that they are defined by the intersection of the plane of the moon's path and the equant circle he has just introduced. Now it is true that the moon's equant circle is in the plane of the sun's path (as Sacrobosco says). And it is true that the circles drawn about equant points may be any size you please, *in all the other models except the moon*. But it is not true for the moon's equant circle that it can be made any size. One of the circle's main functions is to carry the center of the eccentric deferent which carries the epicycle that carries the moon (this device is now known colloquially as a 'crank,' because of its similarity to the mounting of a bicycle pedal). So the size of the moon's equant circle is constrained by the size of the eccentric. Hence Sacrobosco's comment "Deferent and equant of each planet are equal," is simply not true in the case of the moon. Considered as circles, the deferent of the moon and the equant circle of the moon will never intersect, although of course their planes do. It is for this reason that the Head and Tail of the Dragon are usually explained using the ecliptic, which may be drawn to any arbitrary size, and made to intersect the deferent of the moon whether ecliptic and deferent are considered circles or planes. Glogów corrects this in his own figure for the Head and Tail of the Dragon (Fig. 6.5).

More importantly, in his discussion Glogów introduces a firm line between mathematical objects and physical objects. "Let it be noted," he says, "for understanding the text, that the Head and Tail of the Dragon is neither a star nor a real part of the sky" (*non est stella nec pars celi realis*).¹¹

¹¹ (Glogów 1506, m [i] R): "Notandum p[ro] intellectu text[us] q[uo]d caput et cauda draconis no[n] e[st] stella nec p[ar]s celi realis." See also (Glogów 1518, K iii R, para 1): "Notandum pro intellectu textus q[uo]d caput et cauda draconis non est stella nec pars celi realis."

Sacrobosco tells his students that the motion of the moon can be defined by three circles, the equant, the deferent and the epicycle. By contrast Glogów tells us that understanding the motion of the moon requires four orbs and a small sphere. The epicycle sphere is self explanatory. But why *four* orbs? Three of these orbs are the eccentric deferent and the two complementary orbs required to line up the center of the orb system with the center of the cosmos. These look just like the orbs introduced in the case of the sun. However, if you look again at (Fig. 6.4), you will see an additional (white) orb encompassing the whole system, which serves an important function in connection with the Head and Tail of the Dragon. Quite simply, the moon does not cross the ecliptic in the same position every month; the Head and Tail of the Dragon move consistently more than one degree each month and more than 19 degrees each year. The fourth and outermost orb of the moon carries the entire inner orb system around with it, at this speed. Having corrected the annual motion by the precession rate of one degree per century for the sun, Sacrobosco completely ignores this much larger correction for the precession of the moon's nodes. Glogów does not mention these numbers, but his figure and text include the crucial fourth orb.¹²

Sacrobosco's text runs on from the passages about the moon to the other planets:

The deferent and equant of each planet are equal. And understand that both the deferent and equant of Saturn, Jupiter, Mars, Venus, and Mercury are eccentric and outside the plane of the ecliptic, and yet those two [deferent and equant] are in the same plane.¹³

The unwary student might read the first sentence as a continuation of the claims about the moon and its equant, but as we have already seen the deferent and equant of the moon are *not* equal. The situation is different in the case of the other planets. After identifying the center of the eccentric, which will be some distance from the center of the cosmos, and the equant, which is a symmetrical point twice as far away, it was common practice to construct an equant circle (Fig. 6.6). This was done by taking the radius of the deferent and drawing a circle of same radius centered on the equant point. As the epicycle center projects equal arcs in equal times on this circle, it is a handy device for finding the unequal arcs that the epicycle center describes on the eccentric; mark equal intervals on the equant circle and join them by lines to the deferent center, to find the corresponding points on the deferent circle. However, there is nothing special about choosing this radius for the equant circle; a circle of any radius will work. The choice to make it the same size as the deferent is mere convenience, and makes it sure to fit in the same figure. And, of course, as it is a tool for use with the eccentric circle, the equant circle is in the same plane, which is not the plane of the ecliptic. Except for this last point, almost all of this is lost in Sacrobosco, who never mentions equant points, nor that the equant

¹²(Glogów 1506, [l vi V]): “Deinde habet orbe[m] mundo co[n]centricum, aggregatum ex aliis tribus ambiente[m].” See also: (Glogów 1518, K iii V, line 1): “Deinde habet orbem mundum concentricum, aggregatum ex aliis tribus ambientem. (“Next [the moon] has an orb concentric to the [center of the] world, holding together and surrounding the other three”).

¹³(Glogów 1506, [m i] V): “Defere[n]tes quidem et equantes cuius ub[ique] planete sunt equales. Et sciendum q[uod] tam defferens [sic] q[uam]que eq[ua]ns Saturni Jovis Martis Veneris et Mercurii sunt eccentrici et extra superficie[m] ecliptice et tame[n] illi duo sunt in eadem sup[er]ficie.”

Fig. 6.6 Diagram for stations and retrogressions showing epicycle orb, eccentric and equant circles. From (Glogów 1506, fol. m iii R). Bavarian State Library, Res/4 A.gr.b. 430#Beibd.2. [urn:nbn:de:bvb:12-bsb10198086-2](https://nbn-resolving.org/urn:nbn:de:bvb:12-bsb10198086-2). Neither the red spot nor the impressed lines are part of the original image

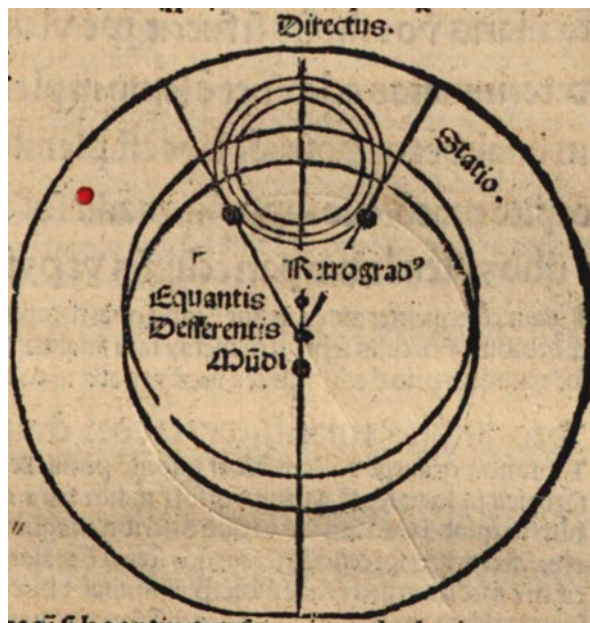

circle is constructed to an arbitrary scale, in contrast to the size the eccentric which is constrained by the motion of the planet, and especially by the need to nest the models for each planet in the correct order, from the moon on the inside to Saturn on the outside. Here again Sacrobosco treats the mathematical concept ‘equant circle’ as if it was on the same level as ‘deferent’ or ‘epicycle’ which have physical counterparts. Glogów sharply contradicts him. In contrast to the real physical orbs corresponding to the deferent and epicycle:

The equant is an imaginary circle, the imagining of which is devised in this way by astronomers, [since] each planet does not move uniformly around the center of the world, nor move uniformly around the center of its deferent, orbs have been imagined by astronomers for the other planets apart from the sun through which their irregularity can be reduced to regularity.¹⁴

Sacrobosco gives no details about the deferents of the planets, beyond saying they are eccentric circles. For Glogów however:

The three outer planets [each] have three real (*realis*) orbs separated from each other and imagined similarly (*similem imaginationem*) to the three orbs of the sun. And in the middle of the orb which is eccentric in the simple sense [each planet] has an epicycle in which the

¹⁴(Glogów 1506, m [i] R para. 1): “[E]quans est circulus imaginarius cuius imaginatio ab astronomis sic est inventa q[uem] eni planete non equaliter moventur semp[er] sup[er] ce[n]tro mu[n]di, nec semp[er] move[n]tur eq[ua]liter sup[er] ce[n]tro deferentiu[m] su[orum] Astronomi ymaginati sunt in aliis planetis a sole per quem illa difformitas reduceretur ad uniformitatem.” See also (Glogów 1518, K iii V): “Equans est circulus imaginarius cuius imaginatio ab astronomis sic est inventa q[uem] a eadem planete non equaliter moventur super super [sic] centro mundi.”

body of the planet is fixed, and from its motion the body of the planet is moved. The author of the *Theoricae* asserts the same thing in the same way for Venus and Mercury. So it should be understood that they call these orbs of the planets “circles” in the old *Theorica*, which are real orbs having a thickness in their substance, but then in truth they are not circles.¹⁵

Sacrobosco, of course, goes on, “An epicycle is a small circle the circumference of which carries the body of the planet and the center of the epicycle is always carried along the circumference of the deferent,” seeming to say, perhaps here most clearly, that the circles move the planets. Glogów responds again, “Last [the author of the *Theoricae novae*] has an immense sphere which is called an epicycle in the depth of the third [eccentric] orb. The body of the moon is fixed in this epicycle.”¹⁶

The main point of Glogów’s corrections to Sacrobosco is his insistence that the parts of *theorica* models must be physically real, while mathematical concepts like points (the Head and Tail of the Dragon) and lines (the eccentric and epicycle circles) are not. Glogów emphasizes the point again by quoting Euclid’s definition of a circle, showing the parts of the definition do not apply to orbs, and repeating: “In the *Theoricae [novae]* there is a real sphere in sky, which leads us to knowledge of the heavens, but the *Theorica [veteres]* call [it] a circle.”¹⁷

Glogów’s commentary on Sacrobosco asserts the reality of Peurbach’s configuration of the heavens against the claims of contemporary Averroists like Nifo and Achillini. From this we can deduce two further claims, made explicitly or implicitly by astronomers like Glogów. To begin with, and contrary to most historians of science throughout the twentieth and into the twenty-first century (North 2008, 335–36), Copernicus was not the first early modern astronomer to insist that astronomical models had to correspond to real physical things. Glogów’s criticisms of Sacrobosco show clearly, as does Brudzewo’s *Little Commentary* on Peurbach, that, well before Copernicus, European astronomers who adopted the *New Theorica*

¹⁵(Glogów 1506, m [i] V): “Quilibet triu[m] superiorum tres orbes habet reales a se divisos secundu[m] ymaginatione[m] triu[m] orbiu[m] solis. In orbe tame[n] medio qui ecce[n]tric[us] e[st] simplicit[er] epicyclu[m] h[ab]et in quo corp[us] planete figit[ur], et ab cuius motu[m] movetur corpus planete, hoc ide[m] in Venere et Mercurio esse idem. Autor theoricarum affirmat. Sciendu[m] etiam q[uam] theoriste [m ii R] orbes istas planetarum qui sunt reales orbes spissitudinem in ea[rum] substa[n]tia habent[es] vocant circulos cu[m] tame[n] secu[n]dum veritatem non sunt circuli[.]” See also (Glogów 1518, K iiiii R para 4): “[Quilibet] trium superiorum tres orbes habet reales a se divisos secundum ymaginationem trium orbes solis. In orbe tamen medio qui eccentricus est simpliciter[,] epicyclum habet in quo corporum planete figitur, et cuius motum movetur corpus planete. Hoc idem in Venere et Mercurio esse idem autor theoricarum affirmat. Sciendum etiam quam theoriste orbes istas planetarum qui sunt reales orbes spissitudinem in earum substantia habentes vocant circulos, cum tunc secundum veritatem non sunt circuli.”

¹⁶(Glogów 1506, [I vi V]): “Ultimo habet sperulam que vocat epicyculus, p[ro]fund[itate] orbis tercii in me[n]sam in quo q[ui]de[m] epicyculo corpus lunare figitur.” See also (Glogów 1518, KiiiV: lines 2–5): “Ultimo habet spherulam que vocat epicyculus, profunditate orbis tertii immensam: in quo epicyculo corpus lunare figitur.”

¹⁷(Glogów 1506, m ii R, para. 1): “...in celo e[st] realis orbis in theoricis q[uam] maneducu[n]t nos in cognitionem celestium apud theoristas vocant circulus.” See also (Glogów 1518, K iiiii R para 4): “...in celo est realis orbis in theoricis que maneducunt nos in cognitionem celestium, apud theoristas vocant circulus.”

were attributing physical reality to the elements of their models. These views were widely shared in commentaries on both Sacrobosco and Peurbach published in Germany, France and Venice (Faber de Budweyß 1495; Capuanus de Manfredonia 1495; Ciruellus 1498; Faber Stapulensis 1503; Barker 2011).

Second, as these author's assertions about celestial orbs did not conform to Aristotle's physics, as understood by many influential contemporaries, their reasoning about the existence of eccentrics and epicycles claimed for astronomy (and other mathematical sciences) the ability to arrive at conclusions that had once been the sole preserve of traditional physics. Copernicus's views on these matters should therefore be located within an existing astronomical tradition. Copernicus contributed to this movement, even if he did not begin it (Barker 2013b). However the most important consequences of these changes may be seen in the program initiated in the sixteenth century by figures from Christophorus Clavius (1538–1612) to René Descartes (1596–1650), to establish science on a new basis that derived its certainty from mathematics applied to observation, rather than prior physical principles (Dear 1995; Schuster 2012). Until quite recently it was common for historians of astronomy to insist that requiring physical significance of mathematical theories was a novelty introduced by Copernicus himself, and that all previous astronomy offered no more than mathematical fictions. As we have seen, there were contemporaries of Peurbach's followers claiming that the orbs were fictitious, but they were adherents of another school in astronomy. They followed Averroes in rejecting eccentrics and epicycles not because they illegitimately substituted orbs for circles or *vice versa*, but because they were regarded as physically impossible, whether as circles or as orbs. Glogów's commentary is an important example of many works that rejected this orthodoxy.¹⁸

References

Primary Sources

- Calonymus, Calo. 1531. *Alpetragii Arabi Theorica planetarum...absque eccentricis et epicyclis*. Venice: L. A. Junta.
- Capuanus de Manfredonia, Franciscus. 1495. *Theoricae novae planetarum Georgii purbachii*. Venice: S. Bevilaqua.
- Ciruellus, Petrus. 1498. *Uberimum sphere mundi*. Paris: Guy Marchant for Jean Petit.
- Copernicus, Nicolaus. 1543. *De revolutionibus orbium coelestium*. Nuremberg: Petreius.
- Cremona, Gerard of. 1472. *Magistri Gerardi Cremonensis viri clarissimi theorica planetarum feliciter incipit*. Ferrara: Andreas Belfortis.

¹⁸I would like to thank Angela Axworthy, Matteo Valleriani and, especially, Kathleen Crowther, for noteworthy help, and the other participants for valuable discussion at the at the 2018 conference "The Authors of the Early Modern Commentaries on *De sphaera*," February 13–15, 2018, at the Max Planck Institute for the History of Science in Berlin.

- de Sacrobosco, Johannes, Georg von Peurbach, and Johannes Regiomontanus. 1482. *Novicijs adolescentibus: ad astronomicam rempublicam capessendam aditum impetrantibus*. Venice: Erhard Ratdolt. <http://hdl.handle.net/21.11103/sphaera.100692>.
- Faber de Budweyß, Wenceslaus. 1495. *Opusculum Ioannis de Sacro Bosco spericum*. Leipzig: Martin Landsberg. <http://hdl.handle.net/21.11103/sphaera.100886>.
- Faber Stapulensis, Jacobus. 1503. *Astronomicon*. Paris: W. Hopyl and H. Estienne.
- Glogów, John of. 1478–1479. *Eclipsis luna gemine totales et una solis p[ar]cial[is] hoc anno testimonio celoru[m] eveniet...accidentia stellaru[m]...Anno d[omi]ni millesimoquadrin-ge[n]tesimo septuagesmonono evenien[ti]a. Ego magister Johannes de Glogovia maori scibere institui*. [Merseburg: By the printer of Isidorus' *Soliloquia* (Marcus Brandis)] HAB shelfmark: H: N 128.4° Helmst. (12).
- . 1479–1480. *Accidentia stellarum...Anno d[omi]ni Mccclxxx ventura. Ego magister johan[n]es de glogovia maiori...scribere institui...*[Merseburg: By the printer of Isidorus' *Soliloquia* (Marcus Brandis), 1479–80.] HAB shelfmark: H: N 128.4° Helmst. (13).
- . 1480–1481. [*Prognosticon*, for Kraków, 1481]. [Leipzig: Marcus Brandis].
- . 1499. *Johannes Versoris Quaestiones super Posteriora analytica Aristotelis (cum textu) Johannes Glogoviensis*. Leipzig: Wolfgang Stöckel, for Johannes Haller.
- . 1499–1500. *Iudicium Cracoviense ad annum 1500*. [Leipzig: Martin Landsberg]. Jagiellonian University Library, call number: BJ. St. Dr. Inc. 2673.
- . 1500a. *Doctrinale puerorum, pars secunda, cum commento Ioannis Glogoviensis*. Leipzig: Wolfgang Stöckel for Ioannes Haller. Jagiellonian University Library, call number: BJ. St. Dr. Inc. 3254.
- . 1500b. *Exercitium super omnes tractatus Parvorum logicalium Petri Hispani, cum textu*. Leipzig: Wolfgang Stöckel for Johannes Haller. Jagiellonian University Library, call number: BJ. St. Dr. Inc. 2596.
- . 1500c. *De octo partibus grammaticis Donati*. Leipzig: Wolfgang Stöckel for Johannes Haller.
- . 1501–1502. *Ad honorem cel[e]situdinemque dei omnipotentis qui omnium rerum naturas prudentissime instituit et ut celestia inferiora gubernarent [et]ordinavit[.] Ego Magister Johannes Glogouiensis Tempora electa ad fleubothomandum et medicinarum solutivarum observanda iuxta motum lune in duodecim signis zodiaci ad annum domini. 1502. currentem describere institui*. [Leipzig: Martin Landsberg]. Jagiellonian University Library, call number: BJ. St. Dr. Cim. vol. 49.
- . 1502–1503. *Accidentia stellarum anno christi Hiesu saluatoris benedicti illesimoquingentesimotertio currente in mundo inferiori nutu dei ventura per magistrum Johannem Glogouiensem iuxta priscorum sapientu[m] experientias et regulas...feliciter recollecta*. Leipzig: Martin Landsberg.
- . 1503. *Minoris Donati de octo p[ar]tibus or[at]ionis co[m]pe[n]diosa interp[re]tatio p[er] magistrum Johanne[m] Glogouie[n]sem p[ro] iuniorum institutio[n]e in Florigera Cracouie[nsis]. Vniue[r]sitate breuiter in vnum recollecta*. Kraków: Jan Haller. <http://jbc.bj.uj.edu.pl/publication/390295/content>. Accessed June 2019.
- . 1504a. *Argumentu[m] i[n] libru[m] porphiry peripatetici ysagogicum in Kathegorias arestotilis...Ego magister Johannes Glogoviensis universitatis...Cracoviensis-collegiatus...magistri Johannis Versoris super veteri arte questiones in levioem modu resolvare institui...* Kraków: Jan Haller.
- . 1504b. *Exercitium secundae partis Alexandri per magistrum Joannem Glogouiensem*. Kraków: Kaspar Hochfeder for Jan Haller.
- . 1506. *Introductorium Compendiosum in Tractatum Spere material magni Joannis de Sacrobusto Qui abbreviauit ex almagesti Sapientis Ptholomei Claudij alexandrini ex pheludio et geniti et magistrum Joannem Glogouiensem...Anno 1506; In vniuersitate Cracouiensi feliciter Recollectum*. [Haller]: Cracow. <http://hdl.handle.net/21.11103/sphaera.100920>.
- . 1506–1507. *Tempora electa ad fleubothomandum et medicinarum solutivarum observanda iuxta motum Lune in duodecim signis celi Zodiaci. Almanach ad annum 1507*. Kraków: Jan Haller. Jagiellonian University Library, call number: BJ St. Dr. Cim. vol. 39.

- . 1507. *Computus Chirometralis, in fine: habes...lector co[m]puti Chirometralis opus (resolutu[m] emendatu[m] et...castigatum ad unum ciclum...76. Annoru[m] qui incipit a. 1482 et durabit ad a. 1558 per magistru[m] Joanne[m] Glogociensem...Anno 1507, quo datu est in luce et impressum.* Kraków: Jan Haller. http://www.wbc.poznan.pl/dlibra/applet?mimetype=image%2Fxdjvu&sec=false&handler=djvu_html5&content_url=%2FContent%2F254559%2Fdirectory.djvu&p=5. Last accessed 13 June 2018.
- . 1511a. *Computus Chirometralis, Denuo reuisum et impressum.* Kraków: Jan Haller.
- . 1511b. *Exercitium nove logice seu librorum priorum et elenchorum Magistri Johannis Glogovia: pro Junioribus recollectum ac noviter emendatum.* Kraków: Jan Haller. HAB shelfmark: M: Lg Sammelbd. 2 (2).
- . 1513. *Introductorium Compendiosum in tractatum Spere materialis magistri Joannis de Sacrobusto quem abbreviauit ex almagesti Sapientis Ptholomei Claudij alexandrine...magistrum Joannem Glogovinensem feliciter recollectum.* Kraków: Florian Ungler & Jan Haller. <http://hdl.handle.net/21.11103/sphaera.100913>.
- . 1514a. *Introductorium Astronomie in Ephemerides, p[er] Magistru[m] Ioanne[m] Glogouiensem in commune[m] studentu[m] in arte stellaru[m] & studio Astronomie p[er] ficere cupientiu[m] vtilitatem In achademia Cracouiensi fauste recollectum].* Kraków: Florian Ungler & Jan Haller.
- . 1514b. *Tractatus preclarissimus in judiciis astrorum de mutationibus aeris, ceterisque accidentibus singulis annis evenientibus...per Ioannem Glogoviensem...atque noviter bene rev.* Kraków: Florian Ungler & Jan Haller.
- . 1518. *Introductorium compendiosum in tractatu[m] sphere materialis m[a]g[ist]r[i] Joannis de Sacrobusto...per m[a]g[ist]r[u]m Joannem Glogouiensem feliciter recollectu[m].* Argentine: Knoblauch. <http://hdl.handle.net/21.11103/sphaera.100260>.
- Nifo, Agostino. 1496. *Summi philosophi Aristotelis...cum Averrois Cordubensis expositionibus.* Venice: Octavian Scot.
- Peurbach, Georg. 1474. *Theoricae novae planetarum.* Nuremberg: Regiomontanus.
- Prosdocimus de Beldomando. 1531. *Patavinus Astronomiae studiosus. S.P.D. Sphaerae mundi.* Fols. 1 R to 56 R in *Sphaerae tractatus. Ioannis de Sacrobusto Anglici viri clariss.* Venice: Lucantonio Giunta. <http://hdl.handle.net/21.11103/sphaera.100999>.
- Sabbioneta, Gerard of. 1472. *Sphaera mundi.* [Venice]: [Florentius de Argentina]. <http://hdl.handle.net/21.11103/sphaera.100685>.
- Verdun, Bernard of. 1961. In *Bernardus de Viriduno Tractatus super totam astrologiam*, ed. Hartmann. Werl, Westf: Dietrich-Coelde.

Secondary Literature

- Aiton, Eric J. 1987. Peurbach's *Theoricae novae planetarum*: A translation with commentary. *Osiris* 3: 5–43.
- Andersen, Hanne, Peter Barker, and Xiang Chen. 2006. *The cognitive structure of scientific revolutions.* Cambridge: Cambridge University Press.
- Axworthy, Angela. 2016. *Prosdocimo de' Beldomandi and Bartolomeo Vespucci on the geometrical definitions of the sphere in Sacrobosco's Sphaera*, Lecture, History of Science Department, University of Oklahoma, 28 April 2018.
- Barker, Peter. 2011. The reality of Peurbach's orbs. In *Change and continuity in early modern cosmology*, ed. Patrick J. Boner, 7–32. New York: Springer.
- . 2013a. Albert of Brudzewo's *Little commentary* on George Peurbach's *Theoricae novae planetarum.* *Journal for the History of Astronomy* 44: 1–24.
- . 2013b. Why was Copernicus a Copernican? *Metascience* 2: 1–6.
- Barker, Peter, and T. Heidarzadeh. 2016. Copernicus, the Tūsi couple and east-west exchange in the fifteenth century. In *Man and cosmos*, ed. M.A. Grenada and P. Boner, 19–57. Barcelona: University of Barcelona Press.

- Benzing, Josef. 1966. Haller, Johann. *Neue Deutsche Biographie* 7:552. <https://www.deutsche-biographie.de/pnd123913934.html#ndbcontent>. Accessed June 2019.
- Crowther, Kathleen, and Peter Barker. 2013. Training the intelligent eye: Understanding illustrations in early modern astronomy texts. *Isis* 104: 429–470.
- Crowther, Kathleen M., et al. 2015. The book everyone read. *Journal for the History of Astronomy* 46 (1): 4–28.
- Dear, Peter. 1995. *Discipline and experience: The mathematical way in the scientific revolution*. Chicago: University of Chicago Press.
- Evans, James. 1998. *Theory and practice of ancient astronomy*. Oxford: Oxford University Press.
- Goddu, André. 2010. *Copernicus and the Aristotelian tradition*. Leiden: Brill.
- Goldstein, Bernard R. 1967. The arabic version of Ptolemy's Planetary hypotheses. *Philadelphia: Transactions of the American Philosophical Society* 57 (4): 3–55.
- . 1971. *Al-Bīrūnī: On the principles of astronomy*. Vol. 2. New Haven: Yale University Press.
- Grant, Edward. 1996. *Planets, stars and orbs*. Cambridge: Cambridge University Press.
- Hasse, Dag N. 2016. *Success and suppression*. Cambridge, MA: Harvard University Press.
- Kren, Claudia. 1968. Homocentric astronomy in the Latin west: The *De reprobatione ecentricorum et epiciclorum* of Henry of Hesse. *Isis* 59: 269–281.
- Kusuba, Takanori, and David Pingree. 2002. *Arabic astronomy in Sanskrit: Al-Birjandi on the Tadhkira II, chapter II and its Sanskrit translation*. Leiden: Brill.
- Lerner, Michel-Pierre. 2008. *Le monde des sphères*. Vol. 2. Paris: Les Belles Lettres.
- Malpangotto, Michela. 2016. The original motivation for Copernicus's research: Albert of Brudzewo's *Commentariolum super Theoricarum novarum Georgii Peurbachii*. *Archive for History of Exact Sciences* 70 (4): 361–411.
- Markowski, Mieczysław. 1981. Die kosmologischen Anschauungen des Prosdocimo de' Beldomandi. In *Studi sul XIV secolo in memoria di Anneliese Maier*, ed. Alfonso Maierù and Agostino Paravicini Bagliani, 263–273. Rome: Edizioni di Storia e Letteratura.
- Morrison, Robert G. 2016. *Joseph ibn Nahmias—the light of the world: Astronomy in al-Andalus*. Berkeley: University of California Press.
- North, John D. 2008. *Cosmos: An illustrated history of astronomy and cosmology*. Chicago: University of Chicago Press.
- Ragep, F. Jamil. 1993. *Nasir al-Din al-Ṭūsī's memoir on astronomy*, 2 vols. New York: Springer.
- Ragep, F. Jamil. 2017. From Tūn to Torun: The twists and turns of the Ṭūsī couple. In *Before Copernicus: The cultures and contexts of scientific learning in the sixteenth century*, ed. R. Feldhay and F.J. Ragep, 161–197. Montreal and Kingston: McGill-Queens University Press.
- Saliba, G. 1987. The rôle of Maragha in the development of Islamic astronomy: A scientific revolution before the Renaissance. *Revue de Synthèse* 108 (3–4): 361–373.
- Saliba, G. 2007. *Islamic science and the making of the European Renaissance*. Boston: MIT Press.
- Sayili, Aydin. 1960. *The observatory in Islam and its place in the general history of the observatory*. Ankara: Türk Tarih Kurumu Basimevi.
- Schmidl, Petra G. 2007. Urđī. In *The biographical encyclopedia of astronomers*, ed. T. Hockey et al., 1161–1162. New York: Springer. https://doi.org/10.1007/978-0-387-30400-7_1404.
- Schuster, John. 2012. Physico-mathematics and the search for causes in Descartes' optics - 1619–1637. *Synthese* 185 (3): 467–499.
- Shank, Michael. 2009. Setting up Copernicus? Astronomy and natural philosophy in Giambattista Capuano da Manfredonia's *Expositio* on the *Sphere*. *Early Science and Medicine* 14 (1): 290–315.
- Sharma, Virendra Nath. 1995. *Sawai Jai Singh and his astronomy*. Delhi: Motilal Banarsidass Publishers.
- Swerdlow, Noel M. 1973. The derivation and first draft of Copernicus's planetary theory: A translation of the *Commentariolus* with commentary. *Proceedings of the American Philosophical Society* 117: 423–512.
- Swerdlow, Noel M., and O. Neugebauer. 1984. *Mathematical astronomy in Copernicus's De revolutionibus*. New York: Springer.

- Sylla, Edith Dudley. 2017. The status of astronomy as a science in fifteenth century Cracow: Ibn al-Haytham, Peurbach and Copernicus. In *Before Copernicus: The cultures and contexts of scientific learning in the sixteenth century*, ed. R. Feldhay and F.J. Ragep, 45–78. Montreal and Kingston: McGill-Queens University Press.
- Szczegola, Hieronim. 1967. *Jan Glogowczyk*. Katowice: Wydawnictwo “Slask”.
- Thorndike, Lynn. 1949. *The Sphere of Sacrobosco and its commentators*. Chicago: University of Chicago Press.
- Toomer, G.J. 1998. *Ptolemy’s Almagest*. Princeton: Princeton University Press.
- van Brummelen, Glen. 2007. Sijzī. In *The biographical encyclopedia of astronomers*, ed. T. Hockey et al., vol. 1059. New York: Springer. https://doi.org/10.1007/978-0-387-30400-7_1279.
- Voss, Don L. 1985. *Ibn al-Haytham’s “Doubts concerning Ptolemy:” A translation and commentary*. PhD dissertation, University of Chicago, Chicago.
- Westman, Robert R. 2011. *The Copernican question*. Berkeley: University of California Press.
- Zinner, E. 1990. *Regiomontanus: His Life and Work*. Trans. E. Brown. Amsterdam: Elsevier.

Open Access This chapter is licensed under the terms of the Creative Commons Attribution 4.0 International License (<http://creativecommons.org/licenses/by/4.0/>), which permits use, sharing, adaptation, distribution and reproduction in any medium or format, as long as you give appropriate credit to the original author(s) and the source, provide a link to the Creative Commons license and indicate if changes were made.

The images or other third party material in this chapter are included in the chapter’s Creative Commons license, unless indicated otherwise in a credit line to the material. If material is not included in the chapter’s Creative Commons license and your intended use is not permitted by statutory regulation or exceeds the permitted use, you will need to obtain permission directly from the copyright holder.

