

TEST RESULTS ON THE VIKING GAS CHROMATOGRAPH-MASS SPECTROMETER EXPERIMENT

K. BIEMANN

Dept. of Chemistry, Massachusetts Institute of Technology, Cambridge, Mass. 02139, U.S.A.

Abstract. The gas chromatograph-mass spectrometer instrument to be utilized in the Viking 1975 Molecular Analysis experiment has undergone preliminary testing in its flight configured version. A synthetic mixture of 24 components as well as a sample of the Murchison meteorite has been used for this purpose. The resulting data did not only allow the identification of most of the organic compounds known to be present, but also revealed the identity of a few unexpected ones. Thus, the sensitivity and reliability of the instrument and data system are satisfactorily demonstrated. Shortcomings revealed by these tests are in the process of being remedied.

Since the last conference on the Origin of Life where the basic principle and design parameters of the instrument to be used in the Viking 1975 molecular analysis experiment had been discussed (Biemann, 1971), its development has reached the flight hardware state. Briefly, the experiment is designed (Anderson *et al.*, 1972) to deter-

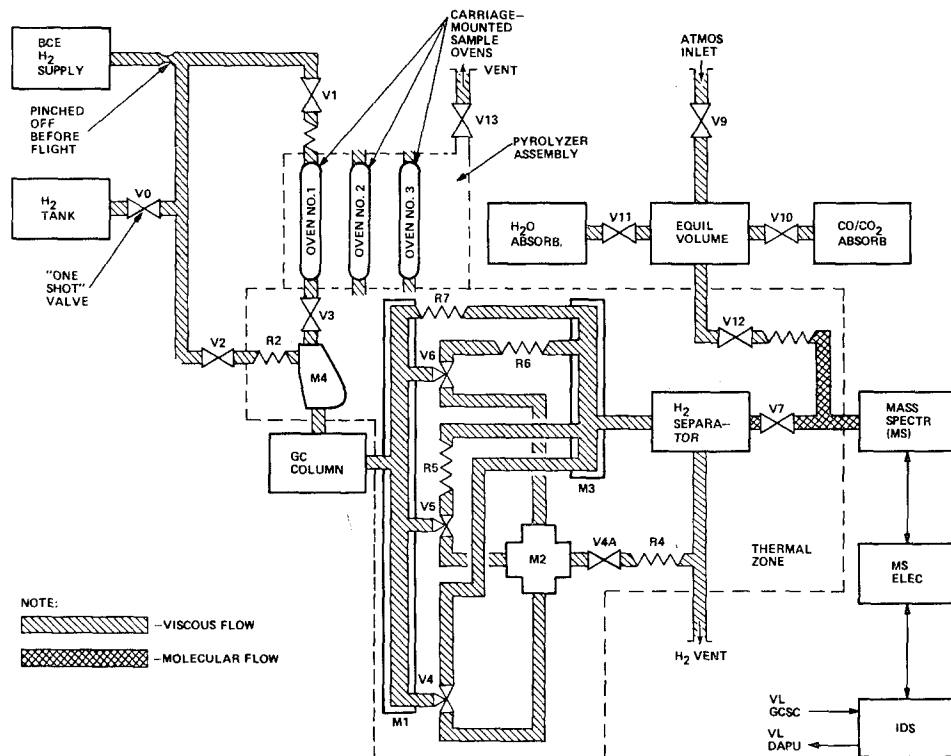

Fig. 1. Gas Flow Block Diagram. Dotted line delineates the heated zone (4 in Figure 2). M1, M2, V4-6 and R4-7 represent the effluent divider (see text).

mine the organic constituents of surface samples by expelling them at 200°C, 350°C and 500°C, respectively into a gas chromatographic column and recording the mass spectra of the components. The mass spectrometer covers the mass range from m/e 12 to m/e 200 with adequate resolution. Water and other inorganic volatiles are detected at the same time. For the analysis of the atmosphere the mass spectrometer without the gas chromatograph is utilized. Practical considerations involving a realistic assessment of the feasibility within the time and funding constraints led to a simplification of the original plans which involved mainly the reduction of the number of samples to be analyzed (from eight to three) and the elimination of the capability to analyze one single sample directly rather than through the gas chromatographic system.

A block diagram of the final design is shown in Figure 1. In addition to the deletions referred to above, the most important sub-component that had been developed since our previous report is the so-called effluent divider. It serves to protect the mass spectrometer and its capacity-limited pump from sudden overpressures that would arise when a large component elutes from the chromatograph and, if permitted to enter the mass spectrometer in its entirety, would temporarily exceed the pumping capacity of the instrument. The effluent divider represents, in effect, a multi-stage gas stream splitter which automatically vents certain fractions of the effluent to the atmosphere. The divider ratio is controlled by the ion pump current to the values 1:0, 1:20, 1:400 and 1:8000. The very high divide ratios of 1:400 and 1:8000 are designed to protect the mass spectrometer in case relatively large quantities of water or carbon dioxide may be evolved from the sample upon heating. Needless to say that the effective sensitivity of the instrument is decreased by the same ratio. It is thus important to choose a gas chromatographic system which is as efficient as possible in the separation of those two substances from the organic compounds of the sample.

A number of units have been built, representing various stages ranging from the so-called science breadboard which was discussed earlier to almost completely flight-configured units. One of those, the development test unit (DTU), is shown in Figure 2. It represents all components of the instrument including the electronics and the data system. It measures $27.5 \times 33 \times 25$ cm and weighs about 20 kg. Its predecessor, the engineering breadboard, in which all essential parts with the exception of the electronics and the data system are in or near flight configuration, has now undergone functional testing using a variety of test samples. These experiments permitted the assessment of its performance, and a preliminary evaluation of its capability to produce interpretable mass spectral data.

Before discussing some of these results it should be noted that the data acquisition and transmission modes have been modified. Rather than greatly condensing the large bulk of the primary data (the electron multiplier output of the mass spectrometer) on board of the Viking Lander, first by mass peak computation to generate the mass spectra (ion abundance vs mass-to-charge ratio) and selectively storing and transmitting to Earth only those spectra recorded when a substance elutes from the chromatograph, all 3800 data points accumulated during each of up to 500 mass spectral scans (10.3 s each) of a gas chromatogram are recorded on a digital tape on board of the

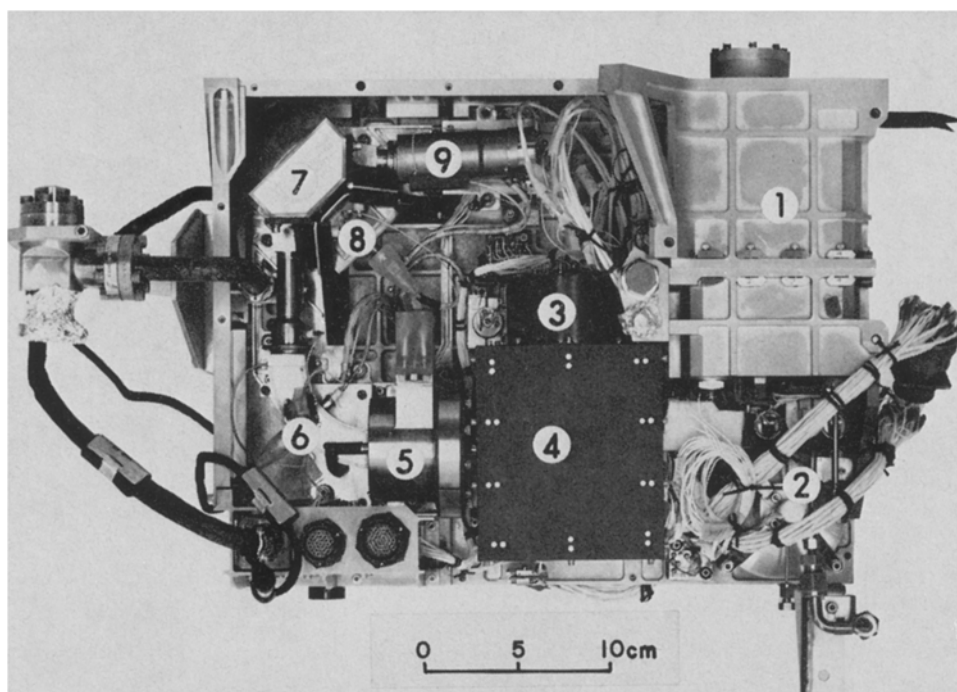

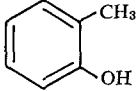
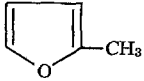
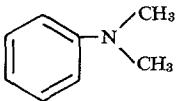



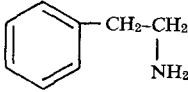
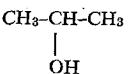
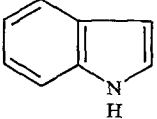
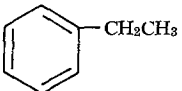
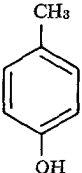
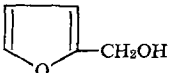
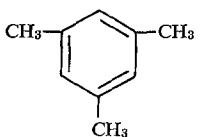
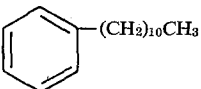

Fig. 2. Development Test Unit of the Viking GC-MS instrument (side view). (1) Sample oven housing. (2) Hydrogen tank. (3) GC-column. (4) Valving, effluent divider, separator (in housing held at 200°C). (5) Ion source housing. (6) Electric sector. (7) Magnet. (8) Ion pump. (9) Electron multiplier.

lander and transmitted to Earth via the Orbiter link. Similarly, all data of an atmospheric experiment are being transmitted. While this may appear to result in the transmission of a large number of unimportant data bits it has the overriding advantage that no information can be lost in the automatic condensation of the original data which can be refined later to any extent desired. Thus, if for one reason or another, the mass calibration would have changed, it could be recognized and corrected at any later time. Transmission of all mass spectra continuously recorded during the gas chromatogram assures that a complete record of every single compound emerging from the gas chromatograph, regardless of its resolution characteristics, will be obtained and one will be able to bring to bear all the computer based evaluation techniques which have been developed over the recent years in our laboratories for very complex gas chromatograph-mass spectrometer data (Hites and Biemann, 1970; Hertz *et al.*, 1971). A unique feature of the Viking mass spectrometer is its wide dynamic range which covers seven orders of magnitude. This range is retained in the data which are recorded and transmitted on a logarithmic scale and converted to linear data on Earth where the data handling computers can easily cope with such a wide dynamic range. This is particularly important in view of the requirement that the instrument has to be capable of detecting minute amounts of organic compounds in the presence of relatively large amounts of others, such as water or carbon dioxide.

TABLE I
24-Component Test Mixture

1.		Furan	13.		ortho-Cresol
2.	$\text{CH}_3=\text{CH}-\text{CN}$	Acrylonitrile	14.	$\text{CH}_3(\text{CH}_2)_9\text{CH}_3$	Undecane
3.		2-Methylfuran	15.		Dimethylaniline
4.		Benzene	16.		Benzylnitrile
5.		2,5-Dimethylfuran	17.		Phenylethylamine
6.	$\text{CH}_3\text{CH}_2\text{CH}_2\text{CH}_2\text{CH}_2\text{CH}_2\text{CH}_2\text{CH}_3$	Octane	18.	$\text{CH}_3(\text{CH}_2)_{11}\text{CH}_3$	Tridecane
7.		Isopentanol	19.		Indole
8.		Ethylbenzene	20.		para-Cresol
9.	$\text{CH}_3(\text{CH}_2)_7\text{CH}_3$	Nonane	21.	$\text{CH}_3(\text{CH}_2)_{13}\text{CH}_3$	Pentadecane
10.		Furfuryl alcohol	22.	$\text{CH}_3(\text{CH}_2)_{13}\text{CH}=\text{CH}_2$	Hexadecene
11.	$\text{CH}_3(\text{CH}_2)_8\text{CH}_3$	Decane	23.	$\text{CH}_3(\text{CH}_2)_{14}\text{CH}_3$	Hexadecane
12.		Mesitylene	24.		Phenylundecane (Solvent)

For the atmospheric experiment both pure gases and mixtures thereof have been admitted through the atmospheric inlet system and their mass spectra measured. These experiments have shown that sensitivity and resolution of the system are adequate and that the carbon monoxide-carbon dioxide adsorption system incorporated in the atmospheric inlet is sufficiently efficient to remove 99% of carbon monoxide and 99.9% of carbon dioxide from an atmospheric sample and thus should permit one to detect nitrogen down to a level of 100 ppm. For the organic experiment both a synthetic test mixture that can be injected into the gas chromatographic system as well as a sample of the Murchison meteorite has been used. The latter permits, in addition to the injection experiments, the evaluation of the performance of the sample oven.

The components of the test mixture (Table I) were chosen to cover the range of organic compounds which the gas chromatograph-mass spectrometer system should be capable of handling and thus to test the adequacy of its performance rather than to represent plausible components of the Martian surface. Phenylundecane was chosen as the solvent because it would elute at the end of the gas chromatogram rather than at the beginning. The gas chromatogram (representing about 5×10^{-8} g of components 1-23 of Table I) is obtained upon plotting the sum of all data points per mass spectrum

24 - COMPONENT TEST

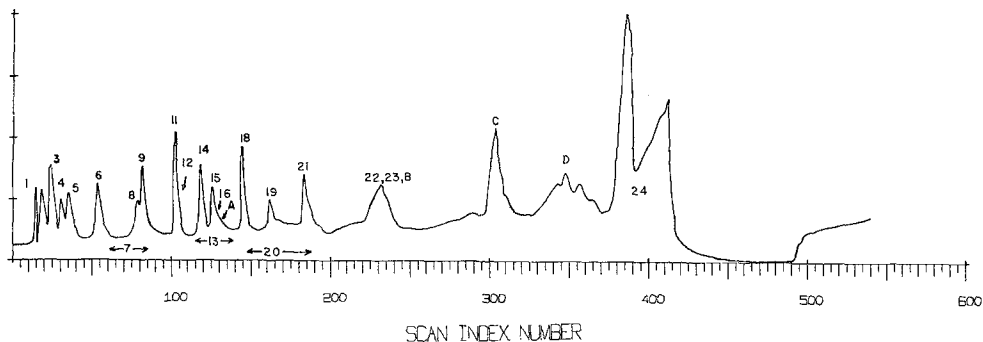

Fig. 3. Gas chromatogram of the 24 component test mixture. Carrier gas flow (hydrogen) 2 ml min^{-1} . Column temperature: 10 min at 50°C , 18 min programmed to 180°C , isothermal at 180°C for 54 min (scan index number $\times 10.3 =$ time elapsed in s).

vs the scan index number of the mass spectrum as shown in Figure 3. Upon conversion of the original data to mass vs intensity values for each mass spectrum as well as further conversion to mass chromatograms, that is plots of individual masses throughout the gas chromatogram (Hites and Biemann, 1970), the various components could be identified. The arabic numbers in Figure 3 relate to those in Table I. Comparison of Figure 3 with Table I reveals, however, that at the 50 ng level three of the components (acrylonitrile, furfurylacohol and phenylethylamine) did not appear in the gas chromatogram. Only a relatively small amount of benzyl cyanide reached the mass spectrometer and other polar compounds like isopentanol and the two cresols emerged as broad peaks. Particularly the latter two could easily be detected by inspec-

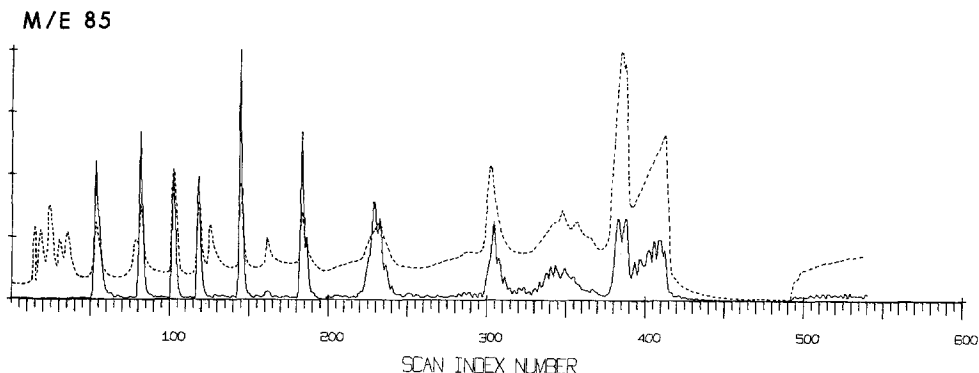

Fig. 4. Mass chromatogram of m/e 85 superimposed on GC-trace of 24-component mixture.

tion of the mass chromatograms of their molecular ions and abundant fragment ions but the same technique did not reveal any of the more polar components (2, 10 and 17 of Table I). Thus, this test revealed that substances of that type are not transmitted through the gas chromatographic column used in these experiments (Chromosorb coated with DEXSIL 300 as the liquid phase and a small amount of a polyester, High-F8, to increase its polarity). These shortcomings revealed by the test experiments are expected to be eliminated by a change of the material to TENAX coated with PMP.

Inspection of the data recorded during the emergence of those portions of the chromatogram labeled A, B, C and D in Figure 3 revealed the presence of four components not previously known to be part of the mixture. Their identification, which is outlined below demonstrates the capability of the Viking-instrument to produce data which can indeed be unambiguously interpreted. The interpretation of continuously recorded mass spectra, particularly after their transformation into mass chromatograms is best illustrated in these examples.

Figure 4 represents a mass chromatogram of m/e 85 which corresponds to $C_6H_{13}^+$, one of the homologous alkyl ions in aliphatic saturated hydrocarbons and other substances having a long saturated alkyl chain. The first few maxima of the solid line (the dotted trace always corresponds to the gas chromatogram that is shown in Figure 3)

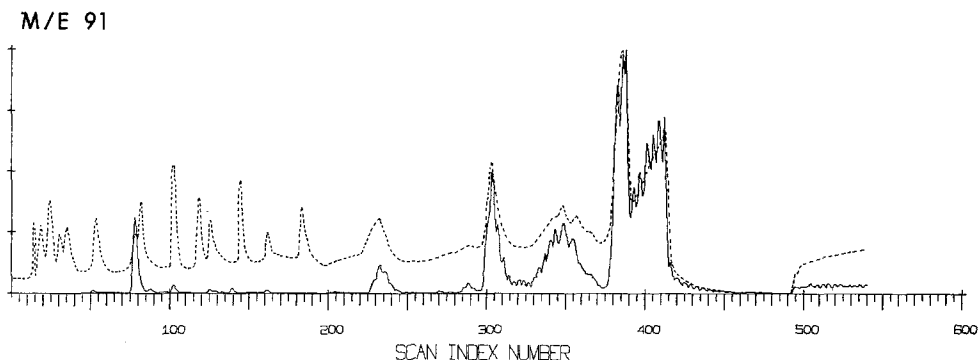

Fig. 5. Mass chromatogram of m/e 91 superimposed on GC-trace of 24-component mixture.

are due to the seven aliphatic hydrocarbons of the test mixture and an inspection of related mass chromatograms of other alkyl ions (m/e 43, 57, 71 and 99, etc.) confirm this identification. The last peak in the gas chromatogram which ranges from scan number 375 to 415 (an appears as a multiplet but only because this large component caused the effluent divider to switch into the 1:20 and 1:400 mode at about scan 385 and 390 respectively) is also paralleled by the m/e 85 trace due to the C_{11} chain in this molecule. The gas chromatographic peaks near scan 302 and around 350 also appear to contain such an aliphatic chain. While none of the components of the test mixture were expected to elute in that area of the gas chromatogram inspection of the mass chromatogram of mass 91 (Figure 5) immediately suggested their identity. The $C_7H_7^+$ ion is, of course, a very abundant one in alkyl benzenes and thus the species where mass 91 maximizes must have such a partial structure. Obviously, phenylundecane does and so does ethylbenzene which is component 8 emerging shortly before nonane. The other maxima of the mass chromatogram of mass 91 which are found around scan 235, 302 and 350 reveal alkyl benzenes not expected in the test mixture. Inspection of mass spectrum number 235 (Figure 6) clearly shows the presence of an aliphatic saturated hydrocarbon as evident from the series of alkyl ions (m/e $43 + 14n$, where $n=0, 1, 2, \dots$) in decreasing intensity as well as of an phenylalkane as deduced from the abundant ions of m/e 91 and 92. The unexpected peak at m/e 204 corresponds to an alkyl benzene with a saturated C_9 substituent.

On the basis of these data one can conclude that phenylnonane elutes almost unresolved from hexadecane and hexadecene, but that the data clearly reveal its presence. While this at first was surprising because phenylnonane had not been added to the test mixture its source is quite obvious. Considering the high sensitivity of the instrument and the fact that phenylundecane has been used as a solvent, i.e., in relatively large quantities, a trace of phenylnonane present in the solvent would of course be

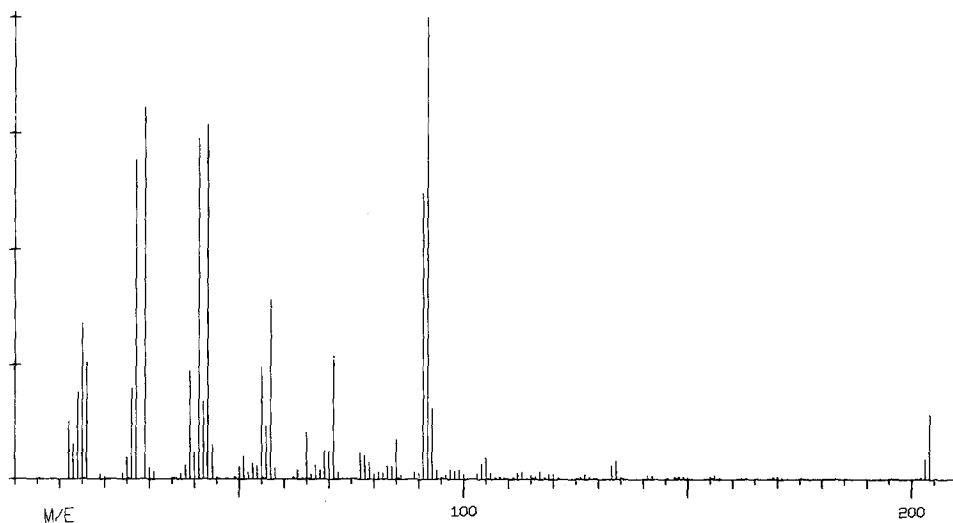

Fig. 6. Mass spectrum corresponding to scan 235 in Figure 3.

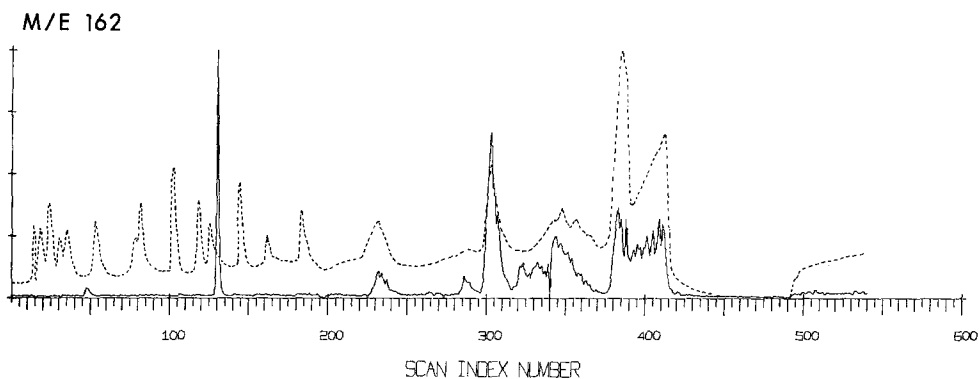

Fig. 7. Mass chromatogram of m/e 162 superimposed on GC-trace of 24-component mixture.

detected. In a similar way the fractions emerging around scan index number 302 and 340 were identified as phenyldecane (component C) and a mixture of isomeric phenylundecanes (component D). Since the latter must have branched alkyl substituents they emerge before the unbranched phenylundecane (solvent, component 24) and are not well resolved thus giving rise to a broader peak.

The utility of mass chromatograms, all of which are generated automatically and available for inspection, is further demonstrated by the detection of another component (A) of the test mixture. Figure 7 represents a mass chromatogram of mass 162 and indicates that a component giving rise to an ion of that mass emerges sharply around scan 130 although this ion is not expected of any of the components of the test mixture (except as the ^{13}C -isotope peak of $\text{C}_6\text{H}_5\text{-C}_7\text{H}_{13}^+$ of the phenylalkanes). Inspection of the mass spectra recorded in that region of the gas chromatogram (which is where dimethylaniline is eluted) showed indeed the sudden appearance of a peak

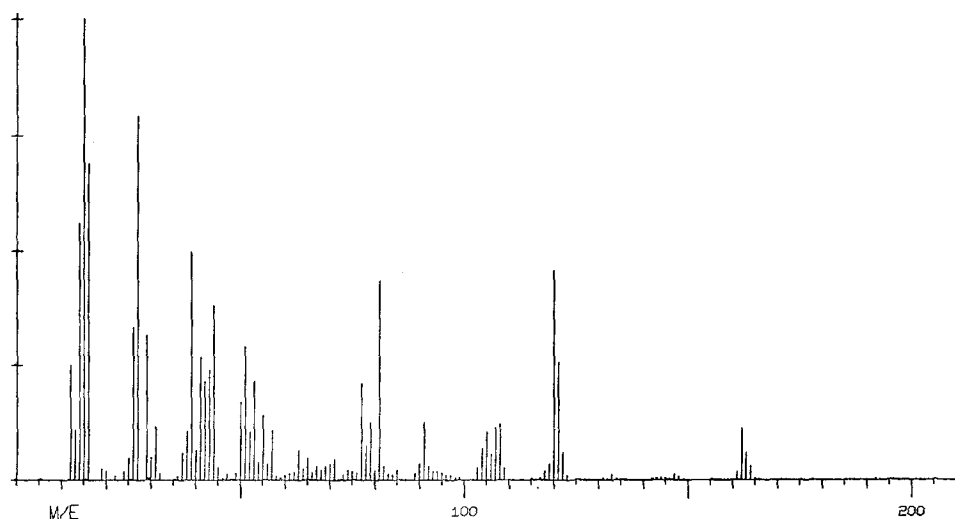
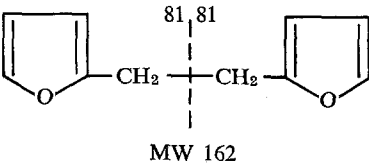

Fig. 8. Mass spectrum corresponding to scan 130 in Figure 3.

at mass 162 (Figure 8) and the only other peak that is not associated with the mass spectrum of dimethylaniline is that at mass 81. Thus, there must be present a trace of a compound which gives rise to abundant ions of mass 162 and mass 81 and both their mass and intensity indicates that it should be a symmetrical aromatic compound with an easily cleaved central bond. Mass 81 is an abundant ion in alkyl furanes and difurylthane is a compound that would be expected to give rise to this mass spectrum. Again it must have been an impurity present in one of the alkyl furanes (most likely methyl furane) of the test mixture. The structures of components A, B, C and D are summarized in Table II.

TABLE II
Additional Components detected in Test Mixture

A.	Difurylthane	
B.	Phenylnonane	$C_6H_5-(CH_2)_8CH_3$
C.	Phenyldecane	$C_6H_5-(CH_2)_9CH_3$
D.	Branched Phenylundecanes	$C_6H_5-C_{11}H_{23}$

These examples indicated that the data generated by the Viking gas chromatograph-mass spectrometer system are such that traces of rather complex organic molecules can be identified without prior knowledge of their presence although the purpose of the test originally was merely to show whether or not the components listed in Table

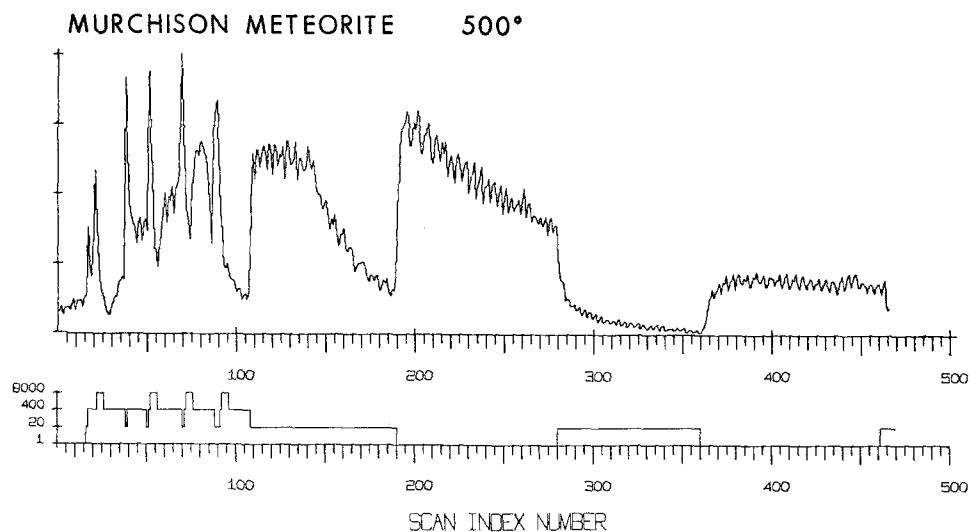

Fig. 9. 'Gas chromatogram' obtained from the effluent of a sample of Murchison meteorite heated to 500°C for 30 s. (top). Effluent divider status (bottom). For explanation see text.

I are transmitted by the system and that the mass spectrometer produces useful mass spectra. In order to evaluate the performance of the instrument on the next level of resemblance to the actual Martian soil sample, a specimen of the Murchison meteorite (approximately 100 mg) was analyzed by placing it into the sample oven of the instrument and heating it to 500°C over a period of 30 s in a stream of hydrogen, the carrier gas for the gas chromatograph.

The 'gas chromatogram' obtained on plotting total ion intensity (summation of individual data points) is shown in Figure 9. Although it appears like a well structured gas chromatogram over the first 100 scans the function of the effluent divider represented on the lower trace in Figure 9 should be taken in to account. It is clear that the sharp peaks around scan index numbers 39, 51, 71 and 90 are due to the divider briefly switching into the 1:20 ratio. The step functions at scan index numbers 108, 190, 280, 360 and 461 are similarly due to changes in divider ratio. Factoring these changes into the total ion intensity plot (top of Figure 9) reveals that the bulk of the signal reaches a maximum around scan index number 80 and decays first rapidly and then slowly during the entire experiment (the ripple on the trace is an artifact introduced by the test equipment). Inspection of the mass spectra reveals the major component to be water released from the sample and eluted from the gas chromatograph in this manner. The data processing techniques developed for such situations permit, however, the detection of individual gas chromatographic fractions eluting 'under' such tails. As an example, the mass chromatogram of m/e 128 is shown in Figure 10 (solid line) superimposed on the total ion plot (broken line) corresponding to Figure 9. Clearly, a substance generating an abundant ion of mass 128 emerges as a sharp peak around scan index numbers 140–144, and the mass spectra recorded at this point are clearly that of naphthalene.

The gas chromatographic trace can be enhanced by removing the contribution of water. The broken line in Figure 11 is obtained when plotting the sum of all ions above m/e 45 and now some fine structure appears. The solid line (mass chromatogram of

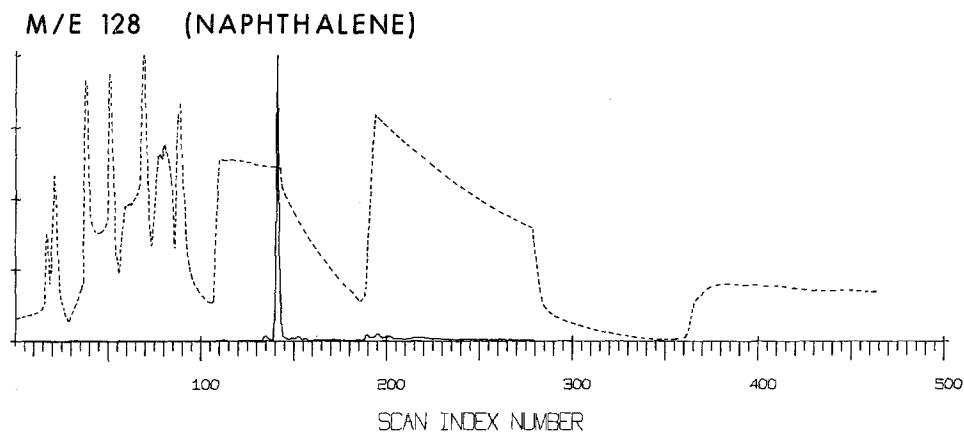

Fig. 10. Mass chromatogram of m/e 128 superimposed on Figure 9.

TABLE III

Viking GCMS	Mol. Mt.	Literature (by benzene extraction and GC; Pering and Ponnampereuma, 1971)
Acetone	58	
Benzene	78	
Thiophene	84	
Toluene	92	
Methylthiophene	98	
C ₂ -Benzene (2 isom.)	106	
C ₂ -Thiophene	112	
C ₃ -Benzene	120	
Indene	118	
	√ ^a 128	Naphthalene
	? 132	?
	√ 142	2-Methyl Naphthalene
	√ 142	1-Methyl Naphthalene
	152	? Not Acenaphthylene or Biphenylene
	180	? Not Stilbene
	√ 154	2,6 Dimethyl Naphthalene
	√ 156	Diphenyl
	√ 156	Dimethyl Naphthalene
	√ 156	1,3 Dimethyl Naphthalene
	168	Diphenyl Methane
	156	1,4 and/or 2,3 Dimethyl Naphthalene
	170	C-3 Naphthalene
	√ 154	Acenaphthene
	168	? Not a Methyl Biphenyl
	√ 166	Fluorene
	184	C-4 Naphthalene
	184	C-4 Naphthalene
	√ 178	Phenanthrene
	178	Anthracene
	192	Methyl Phenanthrene
	192	Methyl Phenanthrene
	192	1-Methyl Phenanthrene
	202	Fluoranthene
	202	Pyrene

^a √ indicates compound listed in left column also detected by Viking GCMS.

m/e 141 due to loss of H from methylnaphthalene and loss of alkyl from higher homologs thereof) represent the elution of the two isomeric methylnaphthalenes around scan index numbers 160 and 164. Mass 156 indicates the emergence of five dimethylnaphthalenes (or, generally speaking, C₂-naphthalenes) at scan index numbers 173, 185, 190, 195 and 201 and inspection of the corresponding mass spectra confirms this conclusion. Using this approach, the components indicated by a check mark in Table III were identified.

Inspection of the mass chromatograms in the region before the emergence of naphthalene revealed the presence of a series of compounds (see Table III) not pre-

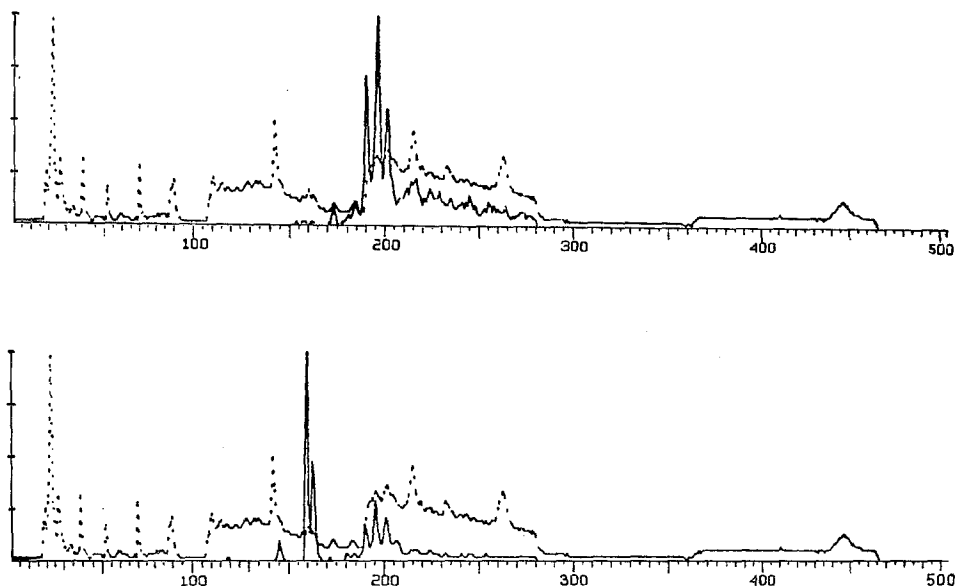

Fig. 11. Mass chromatogram of m/e 141 (bottom) and 156 (top) superimposed on plot of summed ion intensity above m/e 45 (dotted lines) in the Murchison experiment.

viously identified by the wet chemical analysis of the Murchison meteorite (Pering and Ponnampertuma, 1971). Certain ions clearly maximized during the earlier scans and the mass chromatogram of m/e 84 (Figure 12), although obviously enhanced by the effluent divider, is a typical example. Inspection of the mass spectra emerging in this region reveal the presence of thiophene. Similarly, a methylthiophene is detected at scan index number 61 (Figure 13). By deletion of m/e 16, 17, 18, 28 and 44, before plotting the spectrum, the wide dynamic range of the instrument and of the logarithmic recording is taken advantage of.

M/E 84

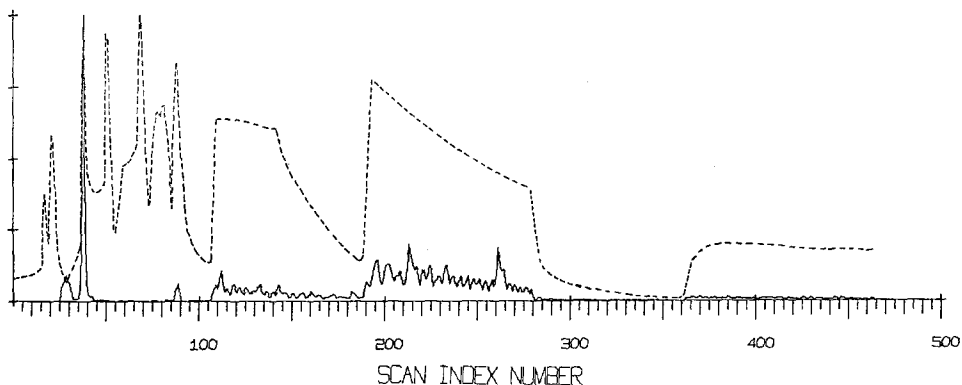

Fig. 12. Mass chromatogram of m/e 84 superimposed on the Figure 9.

As outlined in Table III, benzene and thiophene, along with their lower homologues are released upon heating of the meteorite samples. The good coincidence of the identification of the naphthalenes and higher aromatics by heating as well as extraction suggests that under the conditions of the Viking experiment, no thermal synthesis occurred. The fact that the components more volatile than naphthalene were not

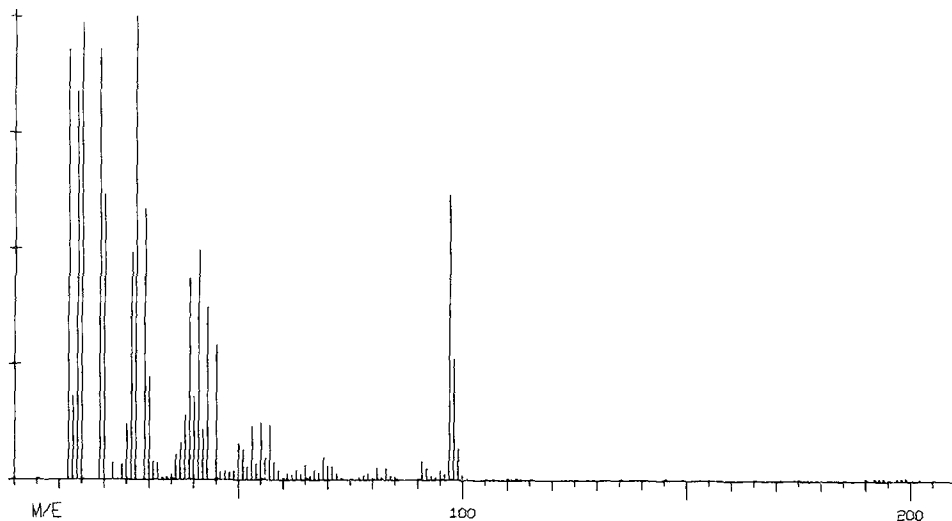

Fig. 13. Mass spectrum corresponding to scan 61 in Figure 9.

detected in the extraction experiment is, of course, due to their loss during solvent removal. Their presence in the Murchison meteorite is not surprising; thiophenes have been found previously in the Murray Meteorite (Hayes and Biemann, 1968).

Both types of test experiments, injection of mixtures and heating of solids, demonstrates that the flight-configured Viking-GC-MS system generates data which make it possible to identify reasonably complex compounds present at the ppm level, or somewhat below, in a 100 mg soil sample. These preliminary tests also revealed a number of shortcomings of the present design, such as the limitations of the gas chromatographic column (DEXSIL 300) with respect to very polar substances, particularly primary and secondary amines and a severely tailing water peak. As pointed out earlier, this is already being remedied. Refinement of the data processing techniques, for example, by incorporation of the effluent divider status (which obviously causes large, abrupt changes in ion intensity) will further facilitate the interpretation of the spectra of minor components emerging simultaneously with major ones. Finally, an extended series of experiments is planned for the very near future, which are designed to evaluate the performance of the instrument in much greater detail (and with the exercise of all the operational modes) than was possible in the tests described here which had to be carried out within the framework of engineering performance tests.

Acknowledgements

The author is indebted to the other members of the Viking Molecular Analysis Team (D. M. Anderson, A. O. C. Nier, L. E. Orgel, J. Oro, T. Owen, G. P. Shulman, P. Toulmin III, and H. C. Urey) Associates of the Team (D. A. Flory, R. A. Hites, A. Lafleur, and P. G. Simmonds) and the personnel of the NASA Contractors (Litton/Ind., Beckman Inst. and Perkin-Elmer Corp.), particularly D. Rushneck and A. Fine, for their contributions, and to the Viking Project for support.

References

- Anderson, D. M., Biemann, K., Orgel, L. E., Oro, J., Owen, T., Shulman, G. P., Toulmin, III, P., and Urey, H. C.: 1972, *Icarus* **16**, 111.
- Biemann, K.: 1971, *Chemical Evolution and the Origin of Life*, p. 541.
- Hayes, J. M. and Biemann, K.: 1968, *Geochim. Geophys. Acta* **32**, 239.
- Hertz, H. S., Hites, R. A., and Biemann, K.: 1971, *Analyt. Chem.* **43**, 681.
- Hites, R. A. and Biemann, K.: 1970, *Analyt. Chem.* **42**, 855.
- Pering, K. L. and Ponnampereuma, C.: 1971, *Science* **173**, 237.