



Evaluation of a mobile-based scaffolding board game developed by scaffolding-based game editor: analysis of learners' performance, anxiety and behavior patterns

Huei-Tse Hou¹ · Chung-Sheng Wu¹ · Chang-Hsin Wu¹

Received: 12 August 2021 / Revised: 23 February 2022 / Accepted: 25 March 2022 /
Published online: 13 April 2022
© Beijing Normal University 2022

Abstract Game-based learning with scaffolding is expected to provide learners with an effective and positive learning environment. This study developed a scaffold-oriented educational game editor that allows teachers to design educational game activities that combine physical board game cards. Players could obtain mobile-based scaffolding by manipulating and scanning the cards. We used the editor to develop a game activity, "Return," for a high school chemistry course, and conducted a preliminary empirical evaluation of the mobile-based scaffolding game. Participants were students in a high school in northern Taiwan. The study analyzed the learning effectiveness, anxiety level, and learning behavior patterns of the learners. Results showed that learners' learning effectiveness improved significantly, and their anxiety level decreased after using the game. Analysis of learning behavior patterns revealed that learners were able to fully utilize the mobile-based cognitive scaffolding and real-time feedback provided in the game to try to combine various hidden clues to solve problems.

Keywords Game-based learning · Educational game editor · Scaffolding · Learning anxiety · Board games

Introduction

Studies have pointed out that a one-way lecture-oriented teaching method may curb students' interest in learning and lead to low learning motivation (Lee & Brophy, 1996). When students continue to lack motivation for learning or have excessive

✉ Huei-Tse Hou
hthou@mail.ntust.edu.tw

¹ Graduate Institute of Applied Science and Technology, National Taiwan University of Science and Technology, #43 Keelung Road, Section 4, Taipei, Taiwan

anxiety about learning, it may have a negative impact on their cognition and emotion (McKeachie, 1984; Vitasari et al., 2010). Previous research has found that the use of games facilitates motivation (Bawa et al., 2018; McLaren et al., 2017) and scaffolding facilitates cognitive thinking (Hou & Keng, 2021; Maryam et al., 2020). Therefore, designing a teaching activity that integrates game mechanics and scaffolding is expected to simultaneously promote learner motivation, reduce anxiety, and enhance learning effectiveness. In this section, this study discuss the design of scaffolding-oriented game-based instructional activities from the literature review and present the research objectives and questions of this study.

Learning anxiety and game-based learning

Learning anxiety can make learners feel nervous, challenged, or scared, and it can therefore affect their learning performance (Ashcraft, 2002). Learners' anxiety about the subject matter affects the learning process. It is one of the important factors that cause students' low self-efficacy (Britner & Pajares, 2006; Lopez & Lent, 1992). For example, Gil-Doménech and Berbegal-Mirabent (2019) found that when teaching in a traditional lecture-oriented way, students showed negative attitudes towards the course and had a low degree of participation. Results of their research indicated that the combination of game-based learning allowed students to generate learning interest and motivation. Combining game-based learning can not only improve learners' learning motivation and learning effectiveness (Bawa et al., 2018), but can also reduce their cognitive load (Chang et al., 2018).

Some studies have found that game-based learning is one of the effective ways to improve students' self-efficacy and reduce their learning anxiety (Chow & Yong, 2013; Meluso et al., 2012). Many research results have shown that teaching with game-based learning strategies can improve learners' learning motivation and learning effects (Bawa et al., 2018; McLaren et al., 2017). Games allow learners to revise learning strategies through independent learning and repeated practice which can cultivate their creativity, problem-solving skills and higher level thinking skills (Hsieh et al., 2015; Hwang et al., 2012; Kim & Chang, 2010). Many research results have indicated that digital game-based learning is more able to improve learning outcomes than traditional teaching (Byun & Joung, 2018; Chang et al., 2018). In addition, the design quality of the scaffolding is a key research issue to promote the cognitive thinking of the learners in game-based learning.

Scaffolding design for game-based learning

The purpose of scaffolding is to provide temporary support while learners solve problems, but also to help gain skills to be able to solve problems independently in the future (Collins et al., 1989; Wood et al., 1976). Appropriate scaffolding design can improve learners' learning motivation and learning effectiveness (Maryam et al., 2020). Puntambekar and Hubscher (2005) believed that scaffolding has two goals: (1) To provide temporary support when learners encounter problems, and (2) To

improve learners' own abilities. Therefore, the scaffold design can guide learners of different levels to break through difficulties when the learning process is blocked, so that they will be able to continue learning.

Digital games can provide scaffolding and real-time evaluation functions. The game can provide real-time diagnosis based on learners' various operation records. The game can give feedback based on the diagnosis result as a form of scaffolding to help them acquire the correct knowledge to improve their abilities and produce better learning effects (Shute, 2008). Studies have also proposed a dual scaffolding educational game architecture that combines cognitive scaffolding and peer scaffolding (Hou & Keng, 2021). In the era of mobile learning, digital games can provide timely scaffolding through mobile vehicles. Learners with different prior knowledge can be provided with adaptive assistance when facing different learning tasks in the game. These scaffolds may reduce learning anxiety when learners are faced with challenging tasks, and can promote the balance between challenges and skills. The balance of challenges and skills can help learners reach a state of flow (Kiili, 2006). Previous research has also found that scaffolding can help students successfully reflect on and correct their mistakes, which in turn effectively reduces student anxiety (Mitchell et al., 2017; Kusmaryono et al., 2020), and that scaffolding can increase student motivation and learning outcomes in collaborative game-based learning environments (Chen & Law, 2016).

However, many studies have found that digital game-based learning still has its limitations, including the lack of face-to-face peer-to-peer interaction and collaboration (Hwang et al., 2012; Lopez & Caceres, 2010). Board games emphasize face-to-face peer-to-peer interaction. Many studies have also found the positive effects of board game-assisted teaching (Hou & Keng, 2021; Kuo et al., 2020; Li et al., 2018). Board games can adapt to the learning content of various subjects, using cards, boards, and simple accessories, making it easy for teachers to design and use them in their teaching practice. Even teachers who do not have a background in information technology can create their own card game activities to match the course teaching. Therefore, many scholars have adopted board games as a learning aid tool, and have actively invested in the research of board game-oriented teaching (e.g., Kuo et al., 2020; Martín-Lara & Calero, 2020; Wang et al., 2019). However, the information content that can be presented by the graphics cards of board games is limited, and it is difficult for board games to present learners with more multimedia information in an adaptive manner as can be done with digital games.

Mobile-based scaffolding for educational game

Therefore, if we can combine the features of face-to-face peer-to-peer interaction in tabletop games with the real-time scaffolding of mobile technology (e.g., augmented reality or image scanning and recognition of cards; e.g., Hou & Keng, 2021; Wu et al., 2018), we may be able to promote learners' collaborative learning motivation through face-to-face game mechanisms, and reduce the anxiety caused by learning challenges through the scaffolding provided by mobile

technology. Therefore, the purpose of this study is to investigate the learning effectiveness and learning process of an educational board game using mobile technology to provide scaffolding.

However, without the expertise of information software or the use of specific editing tools, it is difficult for teachers to design the above-mentioned board games with mobile-based scaffolding. In addition, the general way of scanning card images to present information on mobile devices (such as common QR-codes) can only be used to scan a single card image to display the corresponding information. The existing software cannot perform operations such as combining, sorting, and matching the scaffold information obtained after scanning the images on multiple different cards. These operations can provide more dimensional scaffolding, can be used to evaluate the learning process and status of learners at the same time, and can provide learners with more appropriate and real-time guidance.

Therefore, in this research we also developed an editing tool, the Mobile-Scaffolding-based Educational Card Game Editor (MSECGE), which allows teachers to easily design mobile-based scaffolding card educational games without programming skills.

Research purpose and research questions

To evaluate the mobile scaffolding educational game framework proposed by this research, this research evaluates the educational game by implementing an empirical analysis. The researcher and a high school chemistry teacher used the editor to design a chemistry education board game, and actually used this game to implement game-based learning activities in a high school chemistry course. This research developed an educational game editing tool for teachers to design an educational game with real-time mobile scaffolding, and use it to design a chemistry educational game that combines cognitive scaffolding, a real-time feedback mechanism, and mobile technology. The game is called "Return," and we analyzed learners' learning effectiveness, learning anxiety (Anxiety about studying chemistry) and learning behavior patterns while playing the game. As for the learning behaviors, sequential analysis (e.g., Hou, 2012, 2013, 2015) was used to analyze a large number of learners' operation records to understand their problem-solving behavior patterns in the game.

To explore and evaluate learners' learning effectiveness, anxiety, and behavior patterns in depth, the research questions of this study are as follows:

- 1) After the mobile scaffolding game-based learning activity, did the learners' learning effectiveness improve significantly?
- 2) After the mobile scaffolding game-based learning activity, was there a significant reduction in learners' learning anxiety?
- 3) What is the overall behavioral pattern of learners in the mobile scaffolding game-based learning activity?

Educational board game with mobile-based scaffolding and educational game editor

The proposed mobile scaffolding-oriented board game and its editing tool framework are shown in Fig. 1, the educational game is based on scaffolding design principles and cognitive scaffolding theory (Brush & Saye, 2002; Puntambekar & Hubscher, 2005; Shin et al., 2020; Wood et al., 1976). Teachers can quickly set up the appropriate cognitive scaffolding mechanism, multimedia content and instant feedback mechanism, which can be promoted and widely used in the teaching

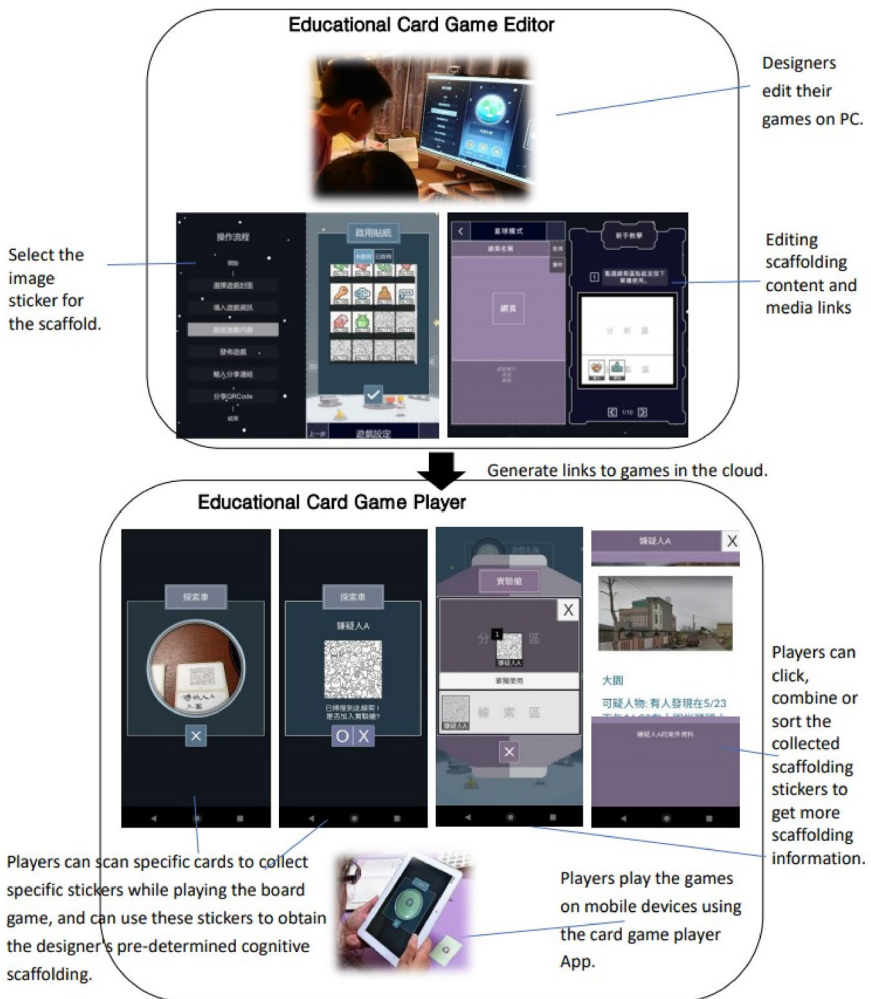

Fig. 1 Framework of educational board game with mobile-based scaffolding and educational game editor

curriculum of various subjects. The Augmented reality (AR) module in this system can scan and recognize some specific image stickers to allow users to obtain specific scaffolding content. Teachers can use this module to set the multimedia content that can be obtained after scanning each sticker scaffold. Teachers can paste image stickers on the board game cards designed by the teachers to allow learners to manipulate, scan, check, assemble, and manage scaffold information to expand the content of pure board game card information. The development of this editing tool aims to allow teachers to design more educational board games that can promote learning effectiveness and reduce learning anxiety. In addition, when using the board game developed by this tool for assisted teaching, the system has an automatic learning action recording function. This function can help teachers conduct formative evaluation (Rowe et al., 2017) to explore the learning process in depth, and it can assist in adjusting teaching strategies and revising the content of teaching materials in a timely manner. Initial tests in the pilot studies (Li, Huang, et al., 2021; Li, Lee, et al., 2021) revealed that there was initial engagement and acceptance of the game activities completed by this editor, but the pilot studies did not describe the theoretical framework and did not conduct a multidimensional analysis of learners' anxiety, learning effectiveness, and learning behavior patterns. Therefore, this study not only completely revised and presented the theoretical framework of mobile scaffolding, but also evaluated the learning outcomes in multiple dimensions.

As shown in Fig. 1, the tool is divided into two applications, the editor and the player, in which users can use the game editor on a personal computer (PC) to set the scaffolding structure in the game. The designer can set those images of stickers to be scanned, the player can scan these stickers and decide whether to collect them in the application (app), and by clicking, combining, or sorting these stickers, they can get various kinds of information content as scaffolding to complete the game tasks in the board game. Designers can also design the content of these cognitive scaffolds (including text, pictures, audio and video, multimedia links.). The designer will use the cards with these images as part of the classroom gamification activities or tabletop games. The designed scaffolding structure will be stored in the cloud, and a link and QR code will be generated for players to scan the code in the player app to get the game-specific scaffolding data. When playing the game, players can use the player app on a mobile device. In the game, players can use the app to scan the cards and get the corresponding scaffolding stickers. After scanning the cards once, players can click on the stickers, or combine and sort the stickers to obtain and read the scaffolding. For example, in Fig. 2, players can combine three cards (two suspect stickers and one police car sticker) to check and obtain intelligence or check if the case was correctly solved. These scaffolds allow players to access additional learning content or guide students to think in more diverse or deeper ways.

In order to evaluate the game and explore the learning process of the players, we designed an educational game named "Return." The game was created using the abovementioned educational game editing tool, MSECGE. This game can be used as a card game teaching activity for chemistry teaching. The context, objectives, procedures and scaffolding of the game are as follows:

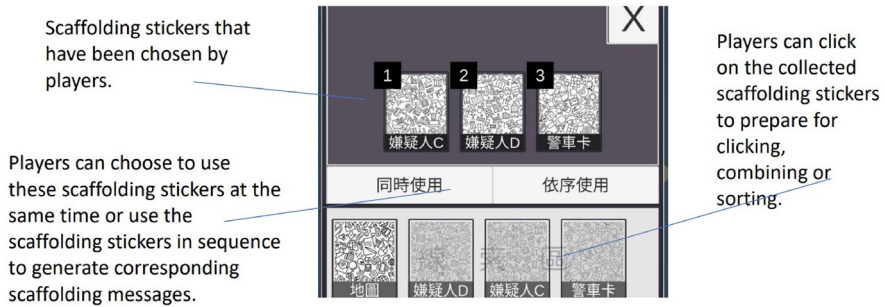

Fig. 2 Players manage and use the collected scaffolding stickers

- (1) **Game scenario:** Learners take on the role of participants in a hot air balloon tournament and go through pre-training. In order to help the participants reach the finish line, return safely to the starting point, and lift the balloon correctly to win the competition, the activity officials provided a board game package called "Return" to help the learners understand the concepts of gas and pressure gauges beforehand.
- (2) **Game procedure and objective:** Players must use the mobile devices, cards, tokens, documents, and other accessories in the provided table game package (as shown in Fig. 3) to solve the various tasks in the game in a group collaboration. Players in each group were first given a certain amount of game points, as shown in Fig. 3, and had to read the game story in the Game App and solve the game tasks within a limited time. They can discuss and analyze the puzzles in the game tasks by reading the information in the given game book and using the

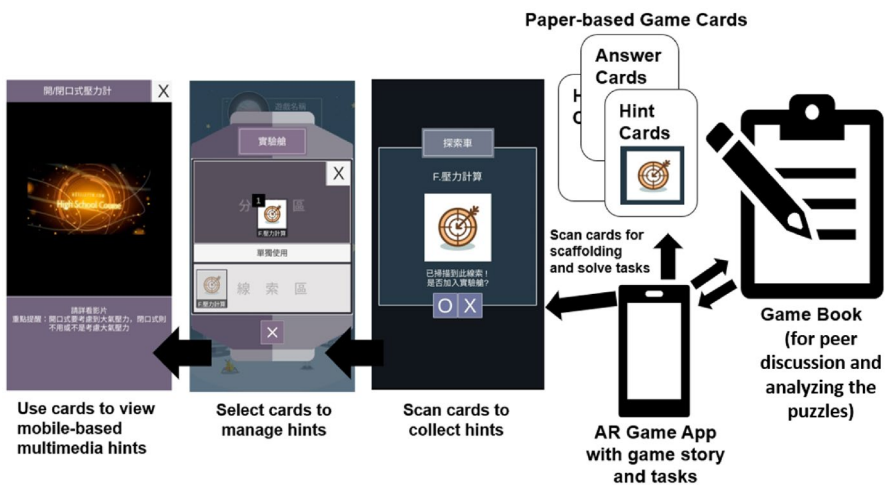

Fig. 3 The procedure of mobile scaffold-oriented educational game—"Return"

tables for analyzing cues in the game book. The game points can be exchanged for hint cards. Players can collect scaffolding hints and think about the answers, and scan and combine the correct answer cards to solve the puzzles.

(3) Scaffolding structure:

This game is based on Hou and Keng's (2021) dual scaffolding framework for AR educational board games, and provides both peer scaffolding and cognitive scaffolding. Of the two types of scaffolding, peer scaffolding is based on Nelson's (1999) collaborative problem-solving teaching method, which provides tasks that groups need to discuss collaboratively with limited time and resources. To solve problems, groups must discuss clues and make decisions. Peers need to provide each other with more information and perspectives to serve as peer scaffolds. The cognitive scaffolding is set by the designer in the editor; players can scan hint cards to gain knowledge and clues to help solve the problem, and can also scan and correctly combine answer cards to instantly check whether the answer is correct, helping learners to get immediate feedback to assist in learning the concepts and knowledge related to gas and pressure gauges. The above two types of card scanning and combination can be used as cognitive scaffolding. Figure 4 shows a player playing a game and scanning a hint card to obtain a cognitive scaffold.

Research methodology

Because this study was affected by the Covid-19 pandemic, the limited time and classroom arrangements were sufficient to conduct only the experimental group analysis without a control group. In order to ensure the overall validity of the study, a behavioral pattern analysis of the behavioral history was conducted for cross-checking to improve the overall validity of the study. Therefore, the research design of this case study is a one group pretest and posttest design. The study was conducted by conducting a preliminary evaluation of

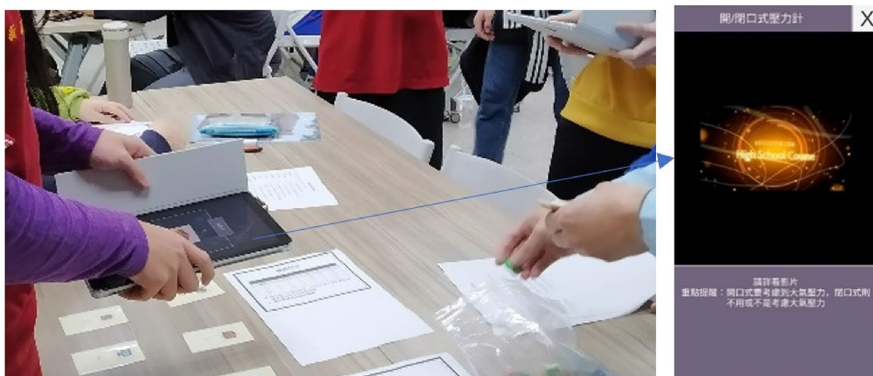

Fig. 4 A player is playing the game and scanning a hint card to get cognitive scaffolding

the learning effectiveness, anxiety and behavioral patterns of players in a game developed using the proposed editor.

Participants

In this study, a high school sophomore class of 31 students (20 boys and 11 girls; average age = 16.5 years old, youngest = 16, oldest = 17) in northern Taiwan were the participants. These students had not previously learned the concept of gas and pressure gauges, and had never played similar educational games. The game was a collaborative problem-solving educational game, so we divided the students into pairs and conducted a collaborative problem-solving game. Participants were grouped into 16 pairs. (Originally, there were 32 participants, but one of them was classified as an invalid sample because of incomplete participation records and completed scale information).

Research instruments

The instruments used in the study included a pre- and post-test evaluation of learning effectiveness, anxiety questionnaires, and a coding scheme of behavior patterns.

(1) Learning effectiveness test

In order to ensure the validity of the questions, the content was designed based on the high school chemistry curriculum standards in Taiwan, and the questions were reviewed by high school chemistry teachers and experts in the field of learning science to ensure expert validity. The scope of the questions was based on the second grade chemistry unit "Gases," and the total number of questions was 20, with 1 point per question. The content of the pretest and posttest was the same.

(2) Anxiety Questionnaire

The anxiety scale used in this study was referenced and adapted from the mAMAS Anxiety Scale (Modified Abbreviated Math Anxiety Scale), which is an anxiety scale developed by Carey et al. (2017) based on the AMAS developed by previous scholars (Hopko et al., 2003). It was modified to examine the anxiety level of the subject (Chemistry in this study). In order to allow learners to compare their pre-game and post-game anxiety about academic subjects, the anxiety questionnaire in this study was administered after the game with nine questions, each of which asked students about their pre-game anxiety and post-game anxiety (both on a five-point scale). In terms of reliability, the overall reliability was .868

(Cronbach's $\alpha=0.868$) after analyzing the questionnaires completed by the learners in this study, which indicates a high degree of internal consistency.

(3) Behavior pattern analysis coding scheme

In order to understand learners' behavior in the game, each mobile device will automatically record each of the learner's actions. The coding schema in this study (Table 1) was modified based on the coding schema of existing studies on game-based learning or learning behaviors (Hou, 2015; Cheng & Tsai, 2014; Hou & Keng, 2021; Chou et al., in press).

Procedure

In this study, a set of board games and mobile devices was used for each pair of students. The study procedure is shown in Table 2, and the process took approximately 100 min. Before the experimental activity started, the purpose and schedule of the experiment were explained to the participants, and they were asked to fill out an informed consent form and then take a pretest of learning effectiveness. The researcher then proceeded to the activity description and game configuration, during which students could ask questions immediately if they had any. Afterwards, participants started the game activities. After the game, they filled out the anxiety questionnaire and finally took the learning effectiveness posttest. There was a certain length of instructional activity time (i.e., 65 min) between the pre and post-tests (Table 3).

Research findings

Learning effectiveness

In terms of learning effectiveness, the results of the dependent sample t test are shown in Table 4, with a mean score of 3.29 and a standard deviation of 2.81 for the pretest of learning effectiveness, and a mean score of 4.52 and a standard deviation of 3.03 for the posttest of learning effectiveness knowledge. It was found that the posttest scores of learning effectiveness were significantly higher than the pretest ($t = -3.26$, $p < 0.01$), indicating that the learners had achieved significant improvement in gas and manometer-related knowledge after learning with the educational game, "Return," designed for this study.

Learning anxiety

In terms of learners' anxiety about chemistry learning before and after using the game, the study used the dependent sample t test to compare learners' anxiety before and after the game. The results are shown in Table 4. The mean score of anxiety

Table 1 Behavior pattern analysis coding scheme

Code	Behavior	Details
GC	Receives scaffold stickers	Scans stickers on cue cards and adds them to the player's sticker library
GA	Gets answer sticker	Scans the sticker on the answer card and adds it to the player's sticker library
SC	Selects scaffold stickers	Selects the scaffold stickers the player wants to use
SA	Selects answer stickers	Selects the answer stickers that the player wants to use
CS	Cancel the selected stickers	Cancel the selected stickers
CI	Obtains scaffolding information successfully	Triggers and obtains scaffolding information successfully
AI	Success in using answer stickers	Success in triggering the correct answer
FI	Uses sticker—no response	No trigger information

Table 2 Research procedure

Steps	Item	Time (min)
Step1	Fill out the consent form for the test	5
Step2	Conduct the learning effectiveness assessment (pre-test)	15
Step3	Set up the game and explain the game	10
Step4	Conducting the game activity	40
Step5	Fill in the anxiety questionnaire (pre- and post-game anxiety comparison)	15
Step6	Conduct the learning effectiveness assessment (post-test)	15
Tota		100

Table 3 Results of learning effectiveness

Variable	Pretest ($N=31$)		Posttest ($N=31$)		t	p	Cohen's d
	M	SD	M	SD			
Pre-post- Posttest	3.29	2.81	4.52	3.03	-3.26	0.003**	0.586

** $p < 0.01$

Table 4 Learners' anxiety about chemistry learning before and after using the game

Variable	Pre-game anxiety ($N=31$)		Post-game anxiety ($N=31$)		t	p	Cohen's d
	M	SD	M	SD			
Pre-anxiety-post-anxiety	26.32	7.73	23.3	8.18	3.02	0.005**	0.544

* $p < 0.05$, ** $p < 0.01$

before the activity was 26.32 with a standard deviation of 7.73, and the mean score of anxiety after the activity was 23.38 with a standard deviation of 8.18. The results indicated that the learners' anxiety level in chemistry learning decreased significantly after learning with the educational game, "Result," designed for this study ($t = 3.02$, $p < 0.01$).

Analysis of overall learner behavior patterns

In this section, we report the analysis of the behaviors of each group of learners during the use of the game, "Return." We used lag sequential analysis, which is commonly used to analyze learning behaviors, to analyze the patterns of learning behaviors. The data analysis step of this analysis method consists of calculating (1) behavior transfer frequency matrix (2) behavior transfer conditional probability matrix (3) behavior transfer expectation matrix (4) behavior transfer residual

(z-score) matrix. In the z-score matrix, a z value greater than 1.96 indicates a statistically significant ($p < 0.05$) continuity from the behavior of the "row" to the behavior of the "column" in the table (Bakeman & Gottman, 1997; Hou, 2012).

Based on the coding results, the significant sequences with z-values greater than 1.96 ($p < 0.05$) (Table 5) were used to map the overall learner behavior patterns (Fig. 5). This study also illustrates and discusses the key behavioral sequences in the overall learners' main learning and problem-solving behavioral patterns. In particular, these behavioral patterns are used to understand the behavior, manner, and timing of the learner's use of scaffolding.

In the overall learner behavior pattern diagram, the sequences of GC → GC, GC → SC, GA → GA, GA → SA, SC → SC, SC → CS, SC → CI, SC → FI, SA → SA, SA → AI, SA → FI, CS → SC, CI → GC, CI → SC, AI → GC, AI → GA, FI → GA, FI → SC, FI → SA are all related to the learning and problem-solving processes of learners during the game. In the behavior mode, GC → GC, GC → SC, SC → CI, and CI → GC is a series of sequences in which players get hints for scaffolding. Learners obtain scaffolding stickers by continuously exchanging hint cards for scanning, and use these stickers to assemble corresponding hints to learn related knowledge. These behavioral patterns also illustrate the process by which learners select and use scaffolds to think about these cues to learn the correct knowledge to facilitate problem solving. The SC → SC, SC → CS, CS → SC, SC → CI, CI → SC, SC → FI, and FI → SC in the overall behavior mode are all related to the behavior code SC (Select Scaffold Sticker). Learners continuously select and deselect scaffolding stickers (SC → CS, CS → SC) to try to obtain more clues, and they continue to try multiple times even though the attempts fail to yield valid information. The above behavioral pattern also illustrates that the SC (scaffolding selection) behavior intersects with other problem-solving behaviors, indicating that learners may repeatedly use scaffolding to learn knowledge. The GA → GA, GA → SA, SA → AI, and AI → GA behaviors show that learners obtain answer stickers by continuously scanning the answer cards, and use them to try to assemble the answers to the levels, while the SA → SA, SA → AI, SA → FI, and FI → SA behaviors show that learners

Table 5 Sequential analysis of all learners (Z-value table)

Z	GC	GA	SC	SA	CS	CI	AI	FI
GC	12.36*	-3.51	7.26*	-3.56	-2.05	-2.01	-0.87	-2.77
GA	-1.95	24.68*	-11.56	3.82*	-5.91	-5.79	-2.52	-7.98
SC	-3.65	-11.67	4.28*	-12.85	11.36*	19.60*	-2.91	2.78*
SA	-3.47	-11.09	-12.61	12.23*	0.89	-6.36	9.17*	16.39*
CS	-0.59	-4.62	10.46*	-0.31	-0.96	-2.61	-1.44	-4.03
CI	7.67*	-1.79	11.12*	-4.45	-3.29	-3.22	-1.40	-4.43
AI	2.20*	6.02*	-2.67	-0.45	-1.33	-1.30	-0.57	-1.80
FI	-0.97	4.39*	4.56*	2.28*	-3.99	-4.44	-1.93	-6.13

* $p < 0.05$

Based on the sequential analysis (see Table 5), the significant sequences with z-values greater than 1.96 ($p < 0.05$) (numbers in bold in Table 5)

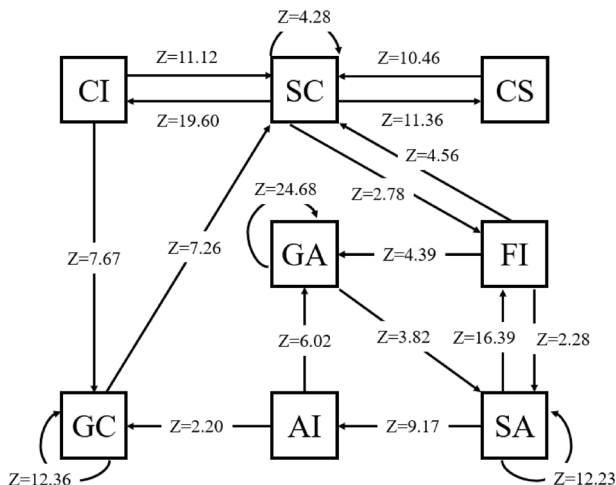

Fig. 5 Sequential behavior pattern of all learners

continuously select answer stickers to try to solve the levels. The AI→GC behavior mode shows that after solving the puzzle, the learner continues to redeem other hint stickers to obtain hints to continue solving the next level.

Discussion

In terms of learning effectiveness, learners' posttest of learning effectiveness was significantly higher than their pretest of learning effectiveness after using the "Return" game, indicating that the game led to a significant improvement in learning effectiveness, and had a positive impact on learners' learning of chemistry knowledge. Appropriate scaffolding design can enhance learners' motivation and learning effectiveness (Maryam et al., 2020). This game was designed using the mobile scaffolding architecture and editor proposed in our research, using mobile online scaffolding with a physical board game. This study makes reference to the dual scaffolding structure (Hou & Keng, 2021), and considers that the peer scaffolding provided by the board game and the cognitive scaffolding provided by the mobile scaffolding should have a positive effect on the learning effectiveness, at least to a certain extent. Mobile scaffolding is also more dynamic than cognitive scaffolding of paper cards in general board games, and can be combined with multimedia. In addition, mobile devices as scaffolding providers can be more portable than desktop computers and can be easily implemented in general classrooms.

In terms of anxiety, learners' anxiety about chemistry after the "Return" game experience was significantly lower than their anxiety before the activity, representing a significant reduction in anxiety about the subject. Studies have found that the use of game-based learning can increase student self-efficacy and reduce their anxiety (Chow & Yong, 2013; Meluso et al., 2012; Young & Wang, 2014). However, the

mechanisms of anxiety reduction have been less explored. In this study, we further propose the use of an immediate online cognitive scaffolding design to try to reduce learners' anxiety when they encounter excessive learning challenges. Scaffolds are helpful in alleviating learning anxiety (Kusmaryono et al., 2020; Mitchell et al., 2017), and the scaffolds in this study provide information about problem solving, which are key cues for learners when they experience difficulty solving problems. These cues are key hints for learners when they encounter problem-solving difficulties. When learners actively explore and collect the scaffolds, they may be able to alleviate their learning anxiety when they experience frustration in problem solving.

In terms of behavioral analysis, this study conducted behavioral pattern analysis through learners' operation process in the game. The behavioral pattern analysis revealed that learners were able to fully utilize the cognitive scaffold and real-time feedback function provided in the game to try to combine various hidden clues to solve the problem. When the answer was wrong, the behavioral pattern also showed that the players would keep actively searching for the unobtained hints to reflect and correct the solution strategy, and further explore and learn in the game. Using this editor, teachers can design dynamic cognitive scaffolding cues to facilitate students' learning. From the above behavior patterns in this case study (e.g., GC → GC, GC → SC, SC → CI, and CI → GC), we can initially understand that learners, with the help of the game's scaffolding, may have a certain degree of repeatedly choosing, correcting, and combining behaviors to solve problems and crack levels. A previous study also found positive effects of scaffolding in educational games on learners' sequential behavior patterns (Hou & Keng, 2021). The above behavioral patterns in this study also illustrate the potential effectiveness of the proposed scaffolding framework in terms of promoting learning effectiveness and reducing anxiety during the learning process. In addition, previous research found that learners' problem-solving sequences in games with high levels of flow showed more reflective processes (Hou, 2015), and the design of scaffolding based on flow elements is a future topic worth exploring to promote a deeper learning process.

Conclusion and Recommendations

This study investigated the learning effectiveness and learning process of an educational board game using the proposed mobile-based scaffolding framework. This study also developed an educational game editing tool for teachers to design educational games with mobile scaffolding, and used it to design an educational game for the subject of chemistry with cognitive scaffolding and a real-time checking mechanism. The study analyzed learners' learning effectiveness, learning anxiety, and learning behavior patterns. It was found that the game significantly improved students' learning effectiveness and reduced their anxiety about chemistry. The behavioral pattern was also found to have a scaffolding, reflection, and problem-solving learning process during the game.

The following recommendations are made for teachers, educational game developers, and future research:

- (1) In teaching practice: The scaffolding framework and editor proposed in this study can be a reference for teachers to design relevant educational games. At present, although there are educational games that integrate scaffolding (e.g., Hou & Keng, 2021; Wu et al., 2018), mobile educational game editors that integrate scaffolding editing functions are still limited. It is suggested that design tools can provide not only learning content, but also scaffolding based on cognitive theory. Formative assessment in games (Rowe et al., 2017) is gaining importance, and scaffolding or diagnostics can be useful for formative assessment. The tools in this study can provide scaffolding and diagnostics, as well as learning history recording, which can help teachers to assess the learning process. In addition, since the learning units studied in the game are smaller in size, the learning content is smaller and therefore significant improvement in learning can be achieved in a shorter period of time. For more learning content, it may be recommended that more learning time is needed to ensure the effectiveness of learning.
- (2) In terms of future research: This study is an initial evaluation of the mobile scaffolding framework, and after confirming the positive impact on learning, a cross-group comparison with various other teaching methods will be conducted in the future. In addition, the system recorded the process when the learners were playing, but it could not record the discussion among learners. Therefore, in the future, we can use audio-recording equipment to record the activity for video-based behavior pattern analysis (e.g., Hou, 2015; Hou & Keng, 2021) to explore deeper learning behaviors.

In addition, regarding the limitations of the study, since this study is only a preliminary case study with a single group pre-post test, there may be an effect on the intrinsic validity due to the same test. Future studies may include a control group for comparison to explore the differences with other teaching methods in more depth or to analyze the usefulness of each scaffold in more depth (e.g., Hou, Fang & Tang, in press). In addition, new digital tools may increase students' motivation for the first time usage, and in the future, it is recommended that longer or continuous weeks of instructional activities be taken to assess whether students have a long-term positive effect (e.g., learning effectiveness promotion) on the games and scaffolding. Future studies can explore whether there is a reduction in anxiety in the discipline after a longer intervention time, or even whether a reduction in anxiety can be achieved consistently. In the future, this study will also evaluate teachers' acceptance of the editor for teaching and learning. The effectiveness of using this approach in other regions' educational approaches and policies is also worth studying.

Funding This study funded by Ministry of Science and Technology, Taiwan (MOST-108-2511-H-011-003 -MY3, Huei-Tse Hou, MOST-107-2511-H-011 -003 -MY3, Huei-Tse Hou, MOST-110-2511-H-011 -004 -MY3, Huei-Tse Hou).

References

- Ashcraft, M. H. (2002). Math anxiety: Personal, educational, and cognitive consequences. *Current Directions in Psychological Science*, 11(5), 181–185.
- Bakeman, R., & Gottman, J. M. (1997). *Observing Interaction: An Introduction to Sequential Analysis* (2nd ed.). Cambridge University Press.
- Bawa, P., Watson, S. L., & Watson, W. (2018). Motivation is a game: Massively multiplayer online games as agents of motivation in higher education. *Computers & Education*, 123, 174–194.
- Britner, S. L., & Pajares, F. (2006). Sources of science self efficacy beliefs of middle school students. *Journal of Research in Science Teaching*, 43(5), 485–499.
- Brush, T. A., & Saye, J. W. (2002). A summary of research exploring hard and soft scaffolding for teachers and students using a multimedia supported learning environment. *The Journal of Interactive Online Learning*, 1(2), 1–12.
- Byun, J., & Joung, E. (2018). Digital game-based learning for K–12 mathematics education: A meta-analysis. *School Science and Mathematics*, 118(3–4), 113–126.
- Carey, E., Hill, F., Devine, A., & Szűcs, D. (2017). The modified abbreviated math anxiety scale: A valid and reliable instrument for use with children. *Frontiers in Psychology*, 8, 11.
- Chang, C. C., Warden, C. A., Liang, C., & Lin, G. Y. (2018). Effects of digital game-based learning on achievement, flow and overall cognitive load. *Australasian Journal of Educational Technology*, 34(4), 2961.
- Chen, C. H., & Law, V. (2016). Scaffolding individual and collaborative game-based learning in learning performance and intrinsic motivation. *Computers in Human Behavior*, 55, 1201–1212.
- Cheng, K. H., & Tsai, C. C. (2014). Children and parents' reading of an augmented reality picture book: Analyses of behavioral patterns and cognitive attainment. *Computers & Education*, 72, 302–312.
- Chou, Y. S., Hou, H. T., Chang, K. E. & Su, C. L. (in press) Designing a cognitive-based game mechanism for mobile educational games to promote cognitive thinking: an analysis of flow state and game-based learning behavioural patterns, *Interactive Learning Environment*.
- Chow, S. J., & Yong, B. C. S. (2013). Secondary school students' motivation and achievement in combined science. *US China Education Review B*, 3(4), 213–228.
- Gil-Doménech, D., & Berbegal-Mirabent, J. (2019). Stimulating students' engagement in mathematics courses in non-STEM academic programmes: A game-based learning. *Innovations in Education and Teaching International*, 56(1), 57–65.
- Collins, A., Brown, J. S., & Newman, S. E. (1989). Cognitive apprenticeship: Teaching the crafts of reading, writing, and mathematics. In L. B. Resnick (Ed.), *Knowing, Learning, and Instruction: Essays in Honor of Robert Glaser* (pp. 453–494). Lawrence Erlbaum Associates.
- Hopko, D. R., Mahadevan, R., Bare, R. L., & Hunt, M. K. (2003). The abbreviated math anxiety scale (AMAS) construction, validity, and reliability. *Assessment*, 10(2), 178–182.
- Hou, H. T. (2012). Exploring the behavioral patterns of learners in an educational massively multiple online role-playing game (MMORPG). *Computers & Education*, 58(4), 1225–1233.
- Hou, H. T. (2013). Analyzing the behavioral differences between students of different genders, prior knowledge, and learning performance with an educational MMORPG: A longitudinal case study in an elementary school. *British Journal of Educational Technology*, 44(3), E85–E89.
- Hou, H. T. (2015). Integrating cluster and sequential analysis to explore learners' flow and behavioral patterns in a simulation game with situated-learning context for science courses: A video-based process exploration. *Computers in Human Behavior*, 48, 424–435.
- Hou, H. T., & Keng, S. H. (2021). A dual-scaffolding framework integrating peer-scaffolding and cognitive-scaffolding for an augmented reality-based educational board game: An analysis of learners' collective flow state and collaborative learning behavioral patterns. *Journal of Educational Computing Research*, 59(3), 547–573.
- Hou, H. T., Fang, Y. S. & Tang, J. T. (in press) Designing an alternate reality board game with augmented reality and multi-dimensional scaffolding for promoting spatial and logical ability, *Interactive Learning Environment*.
- Hsieh, Y. H., Yi-Chun, L., & Hou, H. T. (2015). Exploring elementary-school students' engagement patterns in a game-based learning environment. *Journal of Educational Technology & Society*, 18(2), 336.

- Hwang, G. J., Wu, P. H., & Chen, C. C. (2012). An online game approach for improving students' learning performance in web-based problem-solving activities. *Computers & Education*, 59(4), 1246–1256.
- Kiili, K. (2006). Evaluations of an experiential gaming model. *Human Technology: An Interdisciplinary Journal on Humans in ICT Environments*. <https://doi.org/10.17011/ht/urn.2006518>
- Kim, S., & Chang, M. (2010). Computer games for the math achievement of diverse students. *Journal of Educational Technology & Society*, 13(3), 224.
- Kuo C. C., Fang, Y. S., Wang, S. M., Li, Y. Y., & Hou, H. T. (2020). A preliminary study of a business-management/strategic-planning board game with situated learning mechanisms. In 14th European Conference on Games Based Learning (ECGBL20), 24th – 25th September 2020, Brighton, UK.
- Kusmaryono, I., Gufron, A. M., & Rusdiantoro, A. (2020). Effectiveness of scaffolding strategies in learning against decrease in mathematics anxiety level. *Numerical Jurnal Matematika Dan Pendidikan Matematika*. <https://doi.org/10.25217/numerical.v4i1.770>
- Lee, O., & Brophy, J. (1996). Motivational patterns observed in sixth-grade science classrooms. *Journal of Research in Science Teaching: The Official Journal of the National Association for Research in Science Teaching*, 33(3), 303–318.
- Li, C. T., Keng, S. H., Li, Y. Y., Fang, Y. S., Hou, H. T. (2018). The development and evaluation of an educational board game integrated with augmented reality, role-playing, and situated cases for anti-drug education. Paper presented at ICCE International Conference on Computers in Education (ICCE2018), Nov 26–30, 2018, Manila, the Philippines.
- Li, C. T., Lee, L. H., & Hou, H. T. (2021a). Designing an augmented reality educational board game learning activity with dual-scaffolding teaching strategy to enhance EFL reading comprehension. Paper presented at IIAI International Congress on Advanced Applied Informatics (IIAI LTLE 2021a), July 11th–16th, Online, Japan.
- Li, C. T., Huang, Y. J., Lai, Y. R., Zheng, S. T., Wang, C. J., & Hou, H. T. (2021b). Designing an Augmented Reality-based Educational Board Game Integrated with Dual-Scaffolding Framework for High school History Course: The Evaluation of Learning Performance and Flow State. Paper presented at IIAI International Congress on Advanced Applied Informatics (IIAI LTLE 2021b), July 11th–16th, Online, Japan.
- Lopez, F. G., & Lent, R. W. (1992). Sources of mathematics self efficacy in high school students. *The Career Development Quarterly*, 41(3), 3–12.
- López, J. M. C., & Cáceres, M. J. M. (2010). Virtual games in social science education. *Computers & Education*, 55(3), 1336–1345.
- Martín-Lara, M. A., & Calero, M. (2020). Playing a board game to learn bioenergy and biofuels topics in an interactive, engaging context. *Journal of Chemical Education*, 97(5), 1375–1380.
- Maryam, B., Sören, H., & Gunilla, L. (2020). Putting scaffolding into action: Preschool teachers' actions using interactive whiteboard. *Early Childhood Education Journal*, 48(1), 79–92.
- McKeachie, W. J. (1984). Does anxiety disrupt information processing or does poor information processing lead to anxiety? *International Review of Applied Psychology*, 33, 187–203.
- McLaren, B. M., Adams, D. M., Mayer, R. E., & Forlizzi, J. (2017). A computer-based game that promotes mathematics learning more than a conventional approach. *International Journal of Game-Based Learning (IJGBL)*, 7(1), 36–56.
- Meluso, A., Zheng, M., Spires, H. A., & Lester, J. (2012). Enhancing 5th graders' science content knowledge and self efficacy through game based learning. *Computers & Education*, 59(2), 497–504.
- Mitchell, K. M., Harrigan, T., Stefansson, T., & Setlack, H. (2017). Exploring self-efficacy and anxiety in first-year nursing students enrolled in a discipline-specific scholarly writing course. *Quality Advancement in Nursing Education-Avancées En Formation Infirmière*, 3(1), 4.
- Nelson, L. M. (1999). Collaborative problem solving. *Instructional Design Theories and Models: A New Paradigm of Instructional Theory*, 2, 241–267.
- Puntambekar, S., & Hubscher, R. (2005). Tools for scaffolding students in a complex learning environment: What have we gained and what have we missed? *Educational Psychologist*, 40(1), 1–12.
- Rowe, E., Asbell-Clarke, J., Baker, R. S., Eagle, M., Hicks, A. G., Barnes, T. M., & Edwards, T. (2017). Assessing implicit science learning in digital games. *Computers in Human Behavior*, 76, 617–630.
- Shin, S., Brush, T. A., & Glazewski, K. D. (2020). Examining the hard, peer, and teacher scaffolding framework in inquiry-based technology-enhanced learning environments: impact on academic achievement and group performance. *Educational Technology Research and Development*, 68, 2423–2447.

- Shute, V. J. (2008). Focus on formative feedback. *Review of Educational Research*, 78(1), 153–189.
- Vitasari, P., Wahab, M. N. A., Othman, A., Herawan, T., & Sinnadurai, S. K. (2010). The relationship between study anxiety and academic performance among engineering students. *Procedia-Social and Behavioral Sciences*, 8, 490–497.
- Wang, S. M., Wu, C. H., & Hou, H. T. (2019). Integrating broad game elements, collaborative discussion, and mobile technology to a gamification instructional activity—a case of high school chemical course. *International Journal of Learning Technology and Learning Environment*, 2(2), 11–20.
- Wood, D., Bruner, J. S., & Ross, G. (1976). The role of tutoring in problem solving. *Journal of Child Psychology and Psychiatry*, 17(2), 89–100.
- Wu, C. H., Chen, C. C., Wang, S. M., & Hou, H. T. (2018, July). The design and evaluation of a gamification teaching activity using board game and QR code for organic chemical structure and functional groups learning. In 2018 7th International Congress on Advanced Applied Informatics (IIAI-AAI) (pp. 938–939). IEEE.
- Young, S. S. C., & Wang, Y. H. (2014). The game embedded CALL system to facilitate English vocabulary acquisition and pronunciation. *Journal of Educational Technology & Society*, 17(3), 239–251.

Publisher's Note Springer Nature remains neutral with regard to jurisdictional claims in published maps and institutional affiliations.

Huei-Tse Hou is a Distinguished Professor of Graduate Institute of Applied Science and Technology, National Taiwan University of Science and Technology, Taiwan. He is also the Director of Mini-Educational Game development Group in E-learning Research Center in National Taiwan University of Science and Technology (NTUST MEG). His research interest focuses on e-Learning systems, behavioral pattern analysis and game-based learning systems.

Chung-Sheng Wu is a master student of National Taiwan University of Science and Technology. His research interests include game-based learning and educational board game design.

Chang-Hsin Wu is a PHD student of National Taiwan University of Science and Technology. His research interests include game-based learning and educational board game design.