

Roald Dahl's contribution to neurosurgery: the Wade-Dahl-Till shunt

Dennis R. Buis · Ellen S. Mandl

Received: 28 September 2010 / Accepted: 29 September 2010 / Published online: 12 October 2010
© The Author(s) 2010. This article is published with open access at Springerlink.com

Although most physicians know Roald Dahl (1916–1990) for the many wonderful novels and short stories he wrote, due to a personal tragedy, he is also one of the inventors of the modern ventricular catheters and shunt valves.

In 1960, while living in New York, his then 4-month-old son Theo was hit by a New York taxi and suffered traumatic brain injury with multiple skull fractures and cerebral damage [2]. Theo survived, but developed secondary hydrocephalus. When his condition stabilized after implantation of a ventriculo-atrial shunt, the Dahl family moved back to the United Kingdom in January 1961 [2]. Back in the UK, Theo suffered from hydrocephalus due to multiple shunt obstructions with debris clogging the silicone slits of his Holter valve [2, 5].

Dahl was determined to find a solution to this problem. He contacted Stanley Wade, a toymaker who specialized in making small hydraulic pumps that supplied fuel to model aeroplane engines [2]. Meanwhile Theo's treatment was taken over by pediatric neurosurgeon Kenneth Till at the Hospital for Sick Children at Great Ormond Street in London, who invited both Dahl

and Wade in his operating room so they could see how the shunts were used in clinical practice [2]. Together, they designed a new introducer device for the ventricular catheter and a valve for the treatment of hydrocephalus in young children [3, 4].

The inventors had observed that the valve became obstructed by cerebral debris, which was introduced through the slits of the ventricular catheter when the catheter was inserted through the brain into the ventricles. In order to prevent this, the openings (slits) of the ventricular shunt should not come in contact with brain during the initial placement [4]. A cannula (A) carrying a hollow tube (B) or trocar (D) was inserted through a small dural opening into the ventricles (Fig. 1). The “plug of brain” inside the hollow tube should be removed by the release of cerebrospinal fluid (CSF) or by withdrawal of the tube [4]. With the cannula in place, the hollow tube or trocar was removed, and the ventricular catheter with a stilette (C) was placed into the ventricles (Fig. 1). The cannula was then removed over the ventricular drain with the stilette holding the catheter in place. After removal of the stilette, the ventricular shunt was in place without ever having touched brain [4].

The commercially available valves had another problem: they were expensive and often had plastic components that could not be sterilized [3]. The Wade–Dahl–Till (WDT) valve was made of stainless steel, and patients were only charged the costs to produce the valve [2, 3]. Therefore, the WDT valve cost less than a third of its predecessors [2, 3].

In order to prevent obstruction of the valve, no non-return slits, such as were used in the Holter valve [1], but a moving steel disk was used, therefore CSF could be drained through the widest possible surface. The valve consisted of only six moving parts: a steel disk (E) placed in a four-pronged cage (D) topped with a seat (B) placed in a

D. R. Buis
Neurosurgical Center Amsterdam, VU University Medical Center,
Amsterdam, The Netherlands

E. S. Mandl
Department of Neurosurgery, St. Elisabeth Hospital,
Tilburg, The Netherlands

D. R. Buis (✉) · E. S. Mandl (✉)
Department of Neurosurgery, St. Elisabeth Ziekenhuis Tilburg,
P.O. Box 90151, 5000 LC Tilburg, The Netherlands
e-mail: drbuis@gmail.com

E. S. Mandl
e-mail: ellensmandl@gmail.com

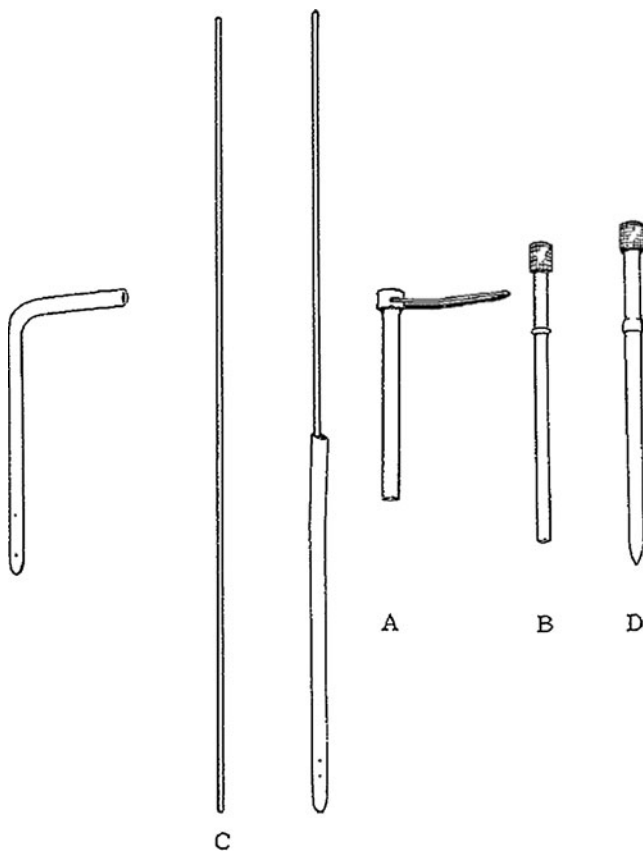

Fig. 1 Introducer system for intraventricular catheter placement. *A* cannula, *B* hollow tube, *C* rigid stilette, *D* trocar (taken from Till [4], with permission)

cylinder (*A*) (Fig. 2). On the side of the seat, the steel disk had a knife-edge round its rim to prevent backflow.

The valve was designed to shunt CSF into a cerebral sinus and thus had an extremely low opening pressure of 0.2–0.5 cm water. When necessary, CSF could be pumped out of the ventricles by applying digital pressure on the valve through the scalp. The inventors explicitly mention the risk of causing subdural hematomas when doing this in older children with a closed fontanel [3].

The WDT valve was taken into production in 1962, and the first patient was treated around June 1962. The WDT valve was estimated to have been used in two to 3,000 children worldwide in the next couple of years, before it became superseded by novel types of valve. Fortunately for

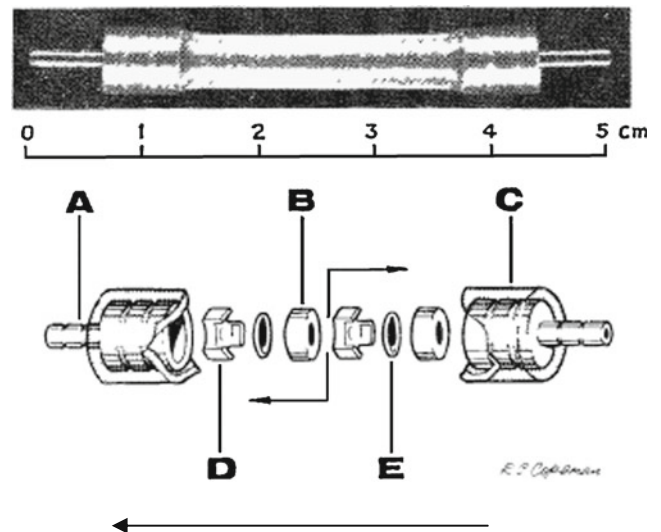

Fig. 2 The Wade–Dahl–Till valve: *A* narrow exit, *B* seat, *C* cylinder, *D* four-pronged cage, *E* steel disk (taken from Till [4], with permission). The bottom arrow represents the direction of flow

Roald Dahl, in 1962, Theo's hydrocephalus turned into an arrested state, and he never received the carefully designed WDT shunt.

Conflicts of interest None.

Open Access This article is distributed under the terms of the Creative Commons Attribution Noncommercial License which permits any noncommercial use, distribution, and reproduction in any medium, provided the original author(s) and source are credited.

References

1. Drake JM, Sainte-Rose C (1995) History of cerebrospinal fluid shunts. In: Drake JM, Sainte-Rose C (eds) *The shunt book*. Blackwell Science, Cambridge, pp 3–12
2. Sturrock D (2010) A tornado of troubles. *Storyteller*. The life of Roald Dahl. Harper Press, London, pp 356–385
3. Till K (1964) A valve for the treatment of hydrocephalus. *Lancet* 283:202
4. Till K (1964) Introducer for intraventricular catheter used in treatment of hydrocephalus. *Lancet* 1:202
5. Treglown J (1995) Punishment and pain, unhappiness and despair. Roald Dahl: a biography. Harvest/HBJ Book, Orlando, pp 136–157