



A Metrological Study of the Late Roman Fort of Umm al-Dabadib, Kharga Oasis (Egypt)

Corinna Rossi¹  · Fausta Fiorillo¹

Published online: 25 May 2018
© The Author(s) 2018

Abstract This article contains a first metrological analysis of the Late Roman Fort of Umm al-Dabadib, built at the beginning of the 4th century AD at the outskirts of the Kharga Oasis, in the Egyptian Western Desert. This site is currently under study by the Italian Archaeological Mission to Umm al-Dabadib; after completing the 3D survey of the building, the team moved to the study of its dimensional patterns. The resulting 3D model was tested for the use of Roman and Egyptian units of measurement, and revealed that the building was planned and built according to the Egyptian Reformed Cubit. The Fort of Umm al-Dabadib, therefore, currently represents the latest attestation of the use of the Egyptian cubit in architecture.

Keywords Building type: Late Roman fort · Geographical area: Egypt · Egyptian Western Desert · Historical era: Late Roman Period · Commensurable ratios · Dimensions · Geometric analysis · Metrology

Introduction

Umm al-Dabadib is a vast and isolated settlement located at the outskirts of the Kharga Oasis, in Egypt's Western Desert (Fig. 1). Its remote position and the dry desert environment allowed both the built-up areas and its associated agricultural system to survive in excellent conditions until today.

Its first mention dates to the early 20th century, when the British explorers John Ball and Hugh Beadnell worked in the Kharga Oasis for the Geological Survey of

✉ Corinna Rossi
corinna.rossi@polimi.it

Fausta Fiorillo
fausta.fiorillo@polimi.it

¹ Department ABC, Politecnico di Milano, Via Ponzio 31, 20133 Milan, Italy

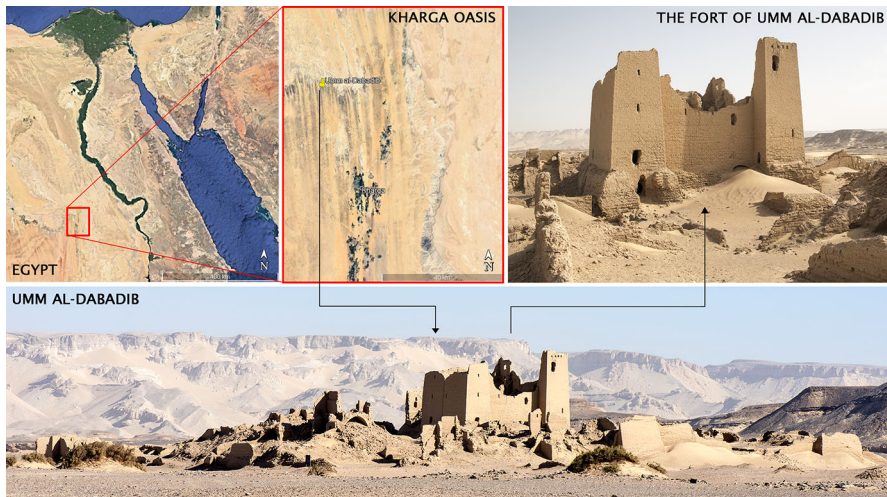

Fig. 1 Position of the Kharga Oasis and of Umm al-Dabadib, and view of the Fort

Egypt (Ball 1900; Beadnell 1909). After a break of over 90 years, Corinna Rossi became interested in the site and started a first general investigation (Rossi 2000); she then co-founded and co-directed the North Kharga Oasis Survey (NKOS) with Salima Ikram from 2001 until 2007 (Ikram and Rossi 2004, 2006, 2007; Rossi and Ikram 2006, 2010, 2013). NKOS performed the first scientific surveys of all the archaeological sites located in the northern portion of the Kharga Oasis, including Umm al-Dabadib (Rossi and Ikram 2018). C. Rossi then focused on Umm al-Dabadib thanks to a grant from National Geographic and Waitt Institute (Fassi et al. 2015; Rossi et al. 2015; Rossi 2016), and in 2016 started the project Living In a Fringe Environment (LIFE), sponsored by a European Research Council Consolidator Grant.

LIFE is organised in two groups, the Archaeological/Architectural Unit, based at the Politecnico di Milano (Host Institution), and the Environmental Unit, based at the Università di Napoli Federico II (Partner Institution). This article presents the first results of the study carried out at the Politecnico di Milano on the 3D survey of the Fort of Umm al-Dabadib.

The Site

Located along the ancient caravan route known today as Darb Ain Amur (Rossi and Ikram 2002, 2013), Umm al-Dabadib might have started its life as a water station between the main core of the oasis and the tiny, isolated water station of Ain Amur, located half-way up the escarpment dividing Kharga and Dakhla oases. The site was probably inhabited in the Late Ptolemaic Period, as suggested by ceramics and grave goods found in the largest and wealthiest cemetery. By the 3rd century AD a

substantial settlement (the Northern Settlement) had grown in a hollow, near an ancient water source accompanied by a small temple.

In the early 4th century AD the site was chosen to host one of the aggressive-looking settlements, consisting of well-built houses laid out on a gridded pattern around a central fortlet, that were built in the desert around Hibis, the capital of the oasis, along the caravan routes that converged there. Others were built at Ain al-Lebekha, Qasr al-Nessima, Mohamed Tuleib and Qasr al-Baramoudy; in the last two cases, this result might have been achieved by modifying existing settlements. In all cases, the central buildings have a sturdy and aggressive appearance and for this reason they are called ‘forts’; however, they are likely to have played a complex role, including (but not confined to) the military component (Rossi and Ikram 2018: Chapters III.1 and III.9).

In the early 4th century AD Umm al-Dabadib thus benefited from a substantial investment that resulted in the construction of the Fortified Settlement (a compact cluster of houses set around the central Fort, located to the south of the older settlement), the enlargement of the Temple (with the addition of a large assembly hall), and the installation of a two vast cultivations fed by a network of seven underground aqueducts that tapped the water under the northern escarpment (Rossi and Ikram: Chapter II.6). These building phase is the focus of the project LIFE and of the study presented here, centred on the Fort.

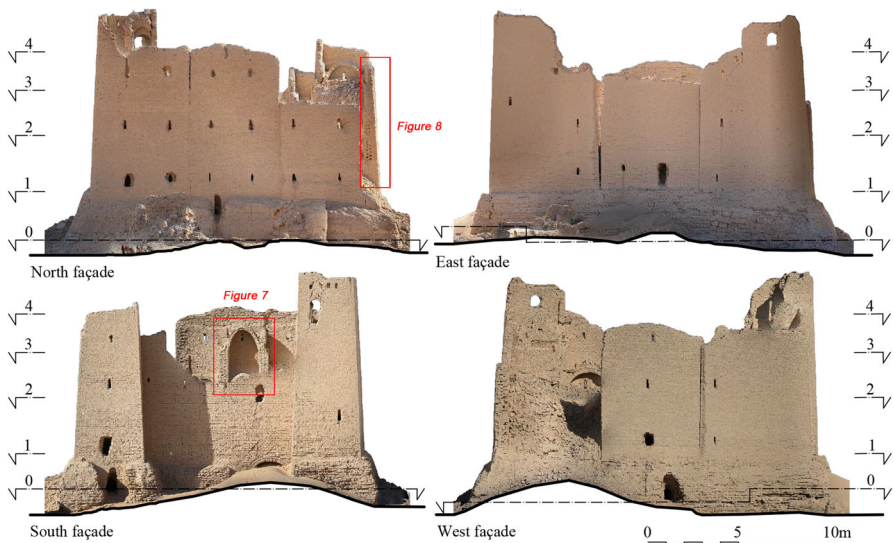

Fig. 2 Elevations of the four façades of the Fort

The Building

The Fort at Umm al-Dabadib is a compact, well-built construction, consisting of five floors, including the ground and the roof levels (Fig. 2). Two square towers protrude from its southern façade; the western one contains a vertical sequence of rooms, whilst the eastern one, taller than the other, contains the staircase and gave access to a window with a commanding view of the southern plain, and to the roof level, now completely collapsed. Both the Fort and the entire Fortified Settlement were visually designed to face south and offer to the approaching travellers the impression of a sturdy, well-defended site (cf. Fig. 1). The few, small entrances to the settlement are in fact located towards the ‘back’, and are nearly concealed from view.

The solid appearance of the Fort is enhanced by the slight slope of the external wall and by the small number of openings that interrupt its surface along the eastern, southern and western sides. Only the northern façade is punctuated by rows of little windows, meant to make the most of the northern, cooler breeze (Rossi and Magli, forthcoming). The external wall (and perhaps the interior structure as well) was subdivided into sections by vertical joints, probably meant to absorb the natural shrinkage of mudbrick walls (cf. Fig. 2; see also Rossi and Ikram: Chapter II.6).

Inside, the building consisted of a ring of rooms distributed around a central courtyard, now filled by the debris of the upper levels. All rooms, with perhaps the exception of some at the uppermost level, were covered by parabolic barrel vaults, that started at a height of about 1 m from the floor level, and all reached more or less the same height; this means that in the smaller rooms the vaults had a marked parabolic shape, whilst in the larger rooms they were similar (but not exactly identical) to round arches. Corridors and doorways were covered by tiny vaults made of three mudbricks, the central one laid flat and supported by two laid diagonally, that gave to the resulting vault a slightly trapezoidal shape (Fig. 3).

Some rooms were endowed with small windows, located high on the wall just under the apex of the vault. The upper levels were served by a staircase running around a central pillar, located in the southeastern tower, near the only entrance to the building. The rooms at ground floor were probably entered directly from the courtyard, whereas it is possible that open-air passages served the rooms of the upper levels (Rossi and Ikram: Chapter III.1).

The excellent state of preservation of this building allowed a precise 3D survey of its volume, both inside and outside; the precision of the resulting survey, in turn, represented a unique chance to perform the metrological study presented in this paper.

The Survey

A first plan and a section of the Fort of Umm al-Dabadib were sketched by Rossi by eye in 1998 (Rossi 2000). In 2003 Rossi and Ikram performed the theodolite survey of the entire site of Umm al-Dabadib; the Fortified Settlement and the Fort were tied

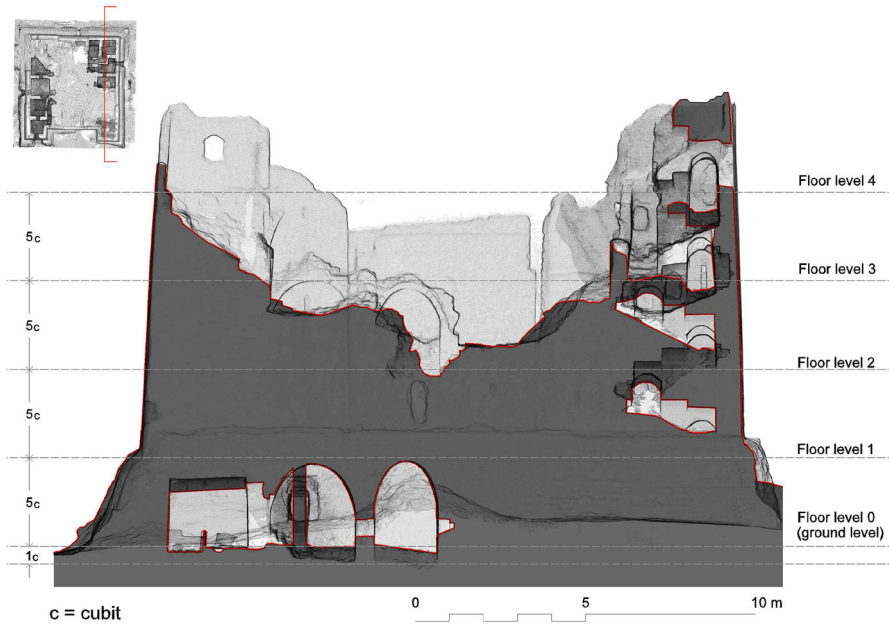

Fig. 3 North-south section of the Fort showing the floor levels and the outline of the parabolic vaults

to the overall survey by means of a loose network of points, and surveyed in detail by laser distance meter by Rossi (Rossi and Ikram 2006).

In 2014 and 2015 Francesco Fassi and Alessandro Mandelli (3D Survey Group at the Politecnico di Milano), under the supervision of C. Rossi, performed the 3D survey of the entire Fortified Settlement (Fassi et al. 2015); the overall accuracy of the survey was 1 cm, with a peak of 3 mm in the Fort (Fiorillo and Rossi 2017). The survey presented significant challenges, both from a logistic and a technical point of view. In particular, the survey of the small, dark interior of the Fort represented the occasion to test on the field the use of fisheye lenses; the satisfactory results of this experiment allowed the 3D Survey Group to successfully apply the same system to the survey of the Minguzzi Staircase, a poorly-lit, 25 m-tall, only 75 cm-wide service staircase running in the façade of the Duomo di Milano (Perfetti et al. 2017).

In 2017 Fausta Fiorillo started the detailed elaboration of the survey data of the Fort and produced a measurable 3D model of the building: a series of dense point clouds and textured mesh models of both the interior and the exterior of the Fort were referenced in the same coordinate system; the unified 3D model, consisting of over 150 million points, was subsampled in order to obtain a manageable point cloud, from which horizontal and vertical sections of the building could be more easily extracted (Fiorillo and Rossi 2017). These represented the basis for the study of the metrology of the building, presented here, and will be used to analyse its structure and to plan the future archaeological activities.

The Identification of the Unit of Measurement

In order to identify the unit of measurement employed in the building, it was necessary first of all to extract plans from the 3D model that would represent each level in the most comprehensive way. Each level had its own issues. Some rooms at ground floor, for instance, are half-filled by sand, whereas others are empty: differently from all the other levels, in order to avoid the sand and yet to keep the horizontal cut below the impost of the vaults, the plan of level 0 (the ground floor) was cut at two different heights in the south-west and north-east areas (cf. Fig. 2). The identification of the best point to horizontally cut the upper floors was decided by combining the scant evidence of the rooms, destroyed or made inaccessible by the internal collapse, and the position of the few windows that punctuate the outer wall.

Then we tested the plans for the presence of the Roman foot (*pes*) of ca 29.5 cm and the Egyptian cubit of ca 52 cm. The ‘precise’ length of these two units of measurement has been the subject of extensive discussions. Measurements of the Roman *pes monetalis*, generally employed in civil and military contexts, vary between 29.1 and 29.7 cm, with a preponderance of the value 29.6 cm (Duncan-Jones 1980; Wilson Jones 2000); average measurements of the Egyptian cubit have been established as about 52.3 cm in the Old Kingdom and Middle Kingdom, about 52.3–53.5 cm in the New Kingdom, and about 53.3 cm in the Greco-Roman Period (Pommerening 2013: 2, see also Hirsch 2013: 1).

Extremely precise measurements, moreover taken at the scale of a building, make, in our opinion, little sense: as the modern expectations on the concept of precision are quite different from the ancient ones (cf. Rossi 2010, Johnstone 2011: 36–8), we believe that the safest choice is to speak about their average (rather than ‘precise’) length.

In our study, we therefore used the approximate values of 29.5 and 52 cm without (further) decimals, for this and for three additional reasons. The first is that detecting and discussing millimetric differences in a mudbrick building makes, again, little sense, as mudbricks get easily eroded in comparison with stone. The second is that we do not believe that in a complex and yet small construction like this one, the fractions of centimetre that we might be ignoring would make any cumulative, significant difference. The third is that plotting errors absorb small details: to a scale 1:50, details smaller than 1 cm cannot be represented; to a scale of 1:100 the plotting error reaches 2 cm: therefore, any measure smaller than these values cannot be properly evaluated and discussed on paper.

This final point finds an obvious correspondence in the architectural practice: extreme precision makes sense in case neat joints must be achieved among rigid elements (e.g. stone elements in ancient architecture, steel components in modern buildings), and in case of astronomic alignments (e.g. the sun hitting the deepest part of the Abu Simbel Temple in two precise days of the year, to remain on Egyptian ground). In the case of a mudbrick building, small variations in the mudbrick dimensions, the varying thickness of the mortar and of the plaster, and the thickness of any cord that might have been used to outline the spaces correspond to

a small amount of centimetres that cannot be fully controlled during the construction. And that, probably, were not taken into any consideration either. For all these reasons, we decided to stick to the average measures of 29.5 and 52 cm.

In order to check both units of measurements, first of all we tested the plans by superimposing on them two grids, one of 29.5 cm, corresponding to the Roman foot, and the other of 52 cm, corresponding to the Egyptian cubit. It is important to highlight that these two grids presented here must be considered as visual tools to highlight the possible presence of their corresponding units of measurements; they are not meant to suggest that the ancient builders actually laid them out on the ground. The use of cords to fix alignments and right angles and to generally mark on the ground the outline of a building is a well-known procedure, for which there is substantial textual and iconographic evidence from ancient Egypt (Rossi 2004: 148–59). The resulting network of cords on the ground might have eventually had the appearance of some sort of grid, but not necessarily corresponding to strict 1-cubit squares (Rossi 2004: 122–8).

We tested the *pes* first, and obtained a number of good matches in terms of internal dimensions of the rooms, especially in the western portion of the building (Fig. 4). The cubit yielded slightly more convincing results: the niches appeared to be exactly 1 cubit wide; the basins containing rests of food supplies both in the north-eastern and south-western rooms appeared to measure exactly 2×2 cubits; the cubit made a better match with the plan of the staircase; and, finally, the grid fitted very well with the internal outline of the building, being perfectly aligned to the interior of the walls of the ground floor rooms (Fig. 5).

By themselves, however, none of these data appeared to be conclusive. The breakthrough for our research was represented by the analysis of the masonry. It is well known that most of the Late Roman constructions in northern Kharga were built using mudbricks which were ca 33–34 cm long, 16–17 cm wide and 8–9 cm high, with the width corresponding to $2/3$ of the length. It has also been noted that the vast majority of the walls of the Fort and of the entire Fortified Settlement, as well as of all the other settlements and forts of northern Kharga, are $1 + 1/2$ mudbrick thick, laid out as one header plus one stretcher (Ikram and Warner 2012; Rossi and Ikram 2018: Chapters III.1 and III.2, esp. pp. 445 and 458).

To our knowledge, so far no attention was paid to the fact that such walls, 52 cm thick, correspond to one Egyptian cubit.

This fact allows us to elaborate further on the type of cubit we are dealing with. 52 cm is the standard length of the ancient Royal Cubit, originally divided into 7 palms (in turn divided into 4 fingers). The ancient Egyptian cubit, however, did not remain the same for its entire history (cf. Hirsch 2013); at the time of the Twenty-sixth Dynasty (7th century BC), the decision was taken to ‘reform’ the cubit: the length remained the same, but it was divided into 6 larger palms (each divided into 4 larger fingers).

Commensurability had always been the moving force behind the evolution of the Egyptian units of measurements (Hirsch 2013) and its importance certainly grew in progression together with trade, that forged contacts between different cultures. One of the reasons behind this change, in fact, might have been the necessity to adopt a

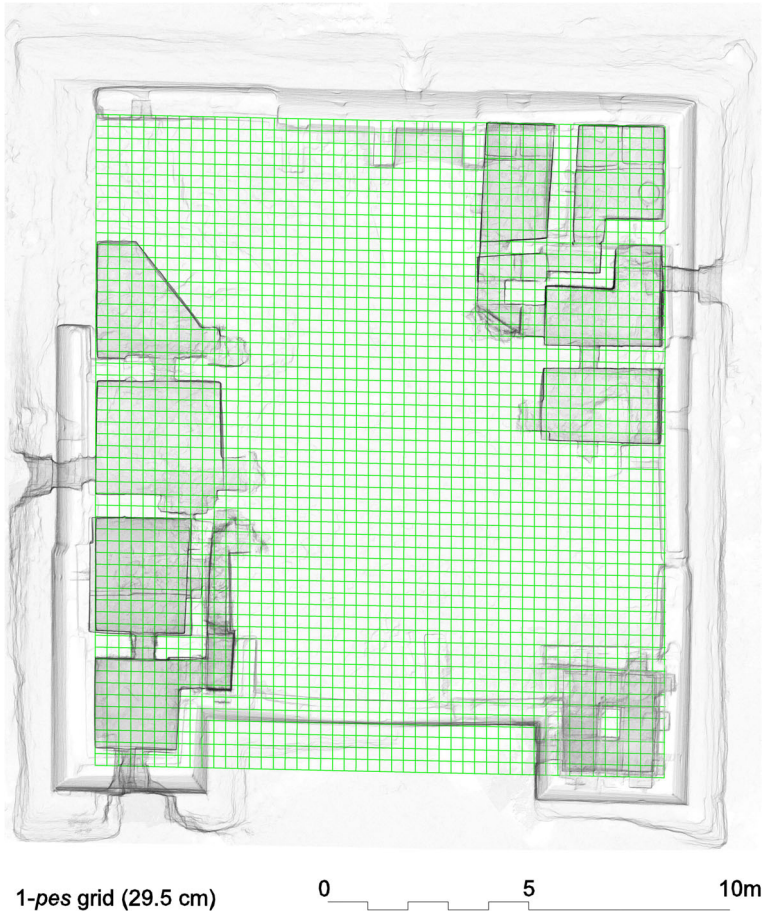

Fig. 4 Top view of the point cloud with 1-pes grid superimposed

unit of measurement that could be more easily commensured with other units of measurements used in the Mediterranean (cf. Wilson Jones 2000: 80–1). To be precise, as the length of the cubit remained the same, the facilitating element corresponded to the subdivision into an even number of parts, 6, instead of the odd number 7.

In the Roman Period several cubits and feet continued to exist alongside one another (cf. Hirsch 2013: 82–5). An important source of information is represented by the metrological papyrus Oxyrhynchus 669, that mentions the foot corresponding to 4 reformed palms (to distinguish it from the Roman or Italic foot of $3 + 1/2$ palms); although the usual label for it was Royal or Ptolemaic, in this instance it is probably called Egyptian (Grenfell and Hunt 1904: 116–21; see also Hirsch 2013: 78). Written around AD 285–287, at the beginning of the reign of Diocletian, this papyrus dates to the same period in which the reinforcement of the Egyptian frontier

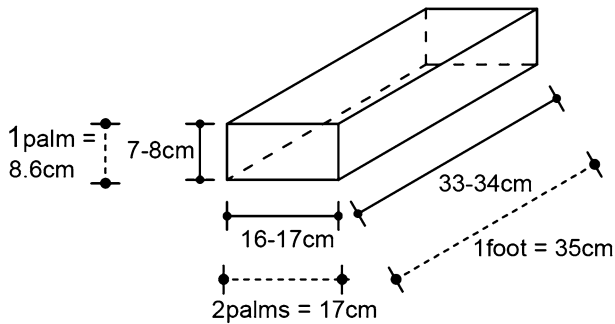

Fig. 5 Top view of the point cloud with 1-cubit grid superimposed

was conceived and carried out by Diocletian himself (Colin 2012: Conclusions; Rossi and Ikram 2018: Chapters III.1 and III.9).

The construction of the Fort at Umm al-Dabadib (and of the other similar installations in northern Kharga) is likely to date to only a few years later, between the very end of the 3rd and the beginning of the 4th century AD: these building operations are therefore compatible not only with the use of the Egyptian (reformed) cubit of ca 52 cm, but also with that of the Egyptian foot of 4 (reformed) palms, corresponding to 35 cm.

The mudbricks employed in the construction of all these sites appear to have been based on the Ptolemaic/Egyptian foot mentioned in p.Oxy. 669: their length was 33–34 cm (just below 1 foot of 35 cm), their width (the head of the mudbrick) was 16–17 cm, corresponding to slightly less than half a foot, that is, two palms (17 cm), and their height, 7–8 cm, to a bit less than one palm (nearly 9 cm) (Fig. 6). It is possible that the mould used to shape the mudbricks was, in fact, just 1 palm



palm = reformed palm
foot = Ptolemaic/Egyptian foot

Fig. 6 Dimensions of the average mudbrick used in the construction of the Fort and the Fortified Settlement of Umm al-Dabadib

high, 2 palms wide, and 1 foot long, thus producing a slightly smaller mudbrick. When laid out as one header plus one stretcher, including the mortar layers, these mudbricks built a one-cubit-thick wall (Fig. 7).

To our knowledge, this is the latest attestation, so far, of the use of the Egyptian cubit in architecture.

The same unit of measurement is likely to have been used not only in the other contemporary installations in the Kharga Oasis (Qasr al-Lebekha and the Gridded Settlement, Mohamed Tuleib, Qasr al-Gib, Qasr al-Sumayra) but also in all the cases in which 52-cm-thick walls (made of one header and one stretcher) appear. Further, detailed studies focusing on all these remains will have to be performed before a final conclusion can be reached, but the outlook is definitely promising.

Even if important elements and details of the Fort of Umm al-Dabadib are buried under sand and debris, it is nevertheless possible to reconstruct the original dimensions of all the accessible rooms and some aspects of the planning and building process, which will be discussed in the following paragraph. From here onwards, ‘cubit’ refers to the reformed cubit (always ca 52 cm), and therefore ‘palm’ refers to the reformed palm of ca 8.6 cm; finally, ‘foot’ refers to the Ptolemaic/Egyptian foot corresponding to 4 palms, for a total length of ca 35 cm.

The Metrological Analysis

The majority of the walls which outline the ground floor rooms of the Fort are 1 cubit thick, corresponding to 1 header and 1 stretcher, or a total of 3 headers (cf. Fig. 7), with the exception of one thinner and one thicker wall, both to be found in the north-eastern rooms (cf. Fig. 5). These are solid and plastered, and thus we have no visibility on their internal structure. However, their dimensions suggest how they were built: the thinner wall is ca 37 cm thick, corresponding most probably to 2 headers plus mortar and plaster (and therefore to 1 foot/4 palms); the thicker wall



Fig. 7 Axonometric view of a detail of the point cloud (along the interior of the northern side of the Fort) showing the mudbrick pattern and its dimensions (cf. Fig. 2 for the position of this wall)

measures ca 68 cm including mortar and plaster, a measure that can be achieved by 2 headers and 1 stretcher, or a total of 4 headers (also corresponding to 2 feet, or to 1 cubit + 2 palms).

These three types of wall (corresponding to 2, 3 and 4 headers) appear also in other contemporary constructions in northern Kharga (Rossi and Ikram 2018: 459). The corridors of the Forts, too, follow this pattern, as they are either 1 cubit or 2 feet wide.

The western wall of the Fort, partly collapsed, offers interesting evidence on the way the mudbricks were assembled to achieve different thicknesses (Fig. 8, see also Fig. 2 for the position of this wall). Here it is possible to see that the lowest

Fig. 8 Orthoimage of the vertical section of the wall along the western side of the Fort, showing how the decreasing thickness was obtained (cf. Fig. 2 for the position of this wall)

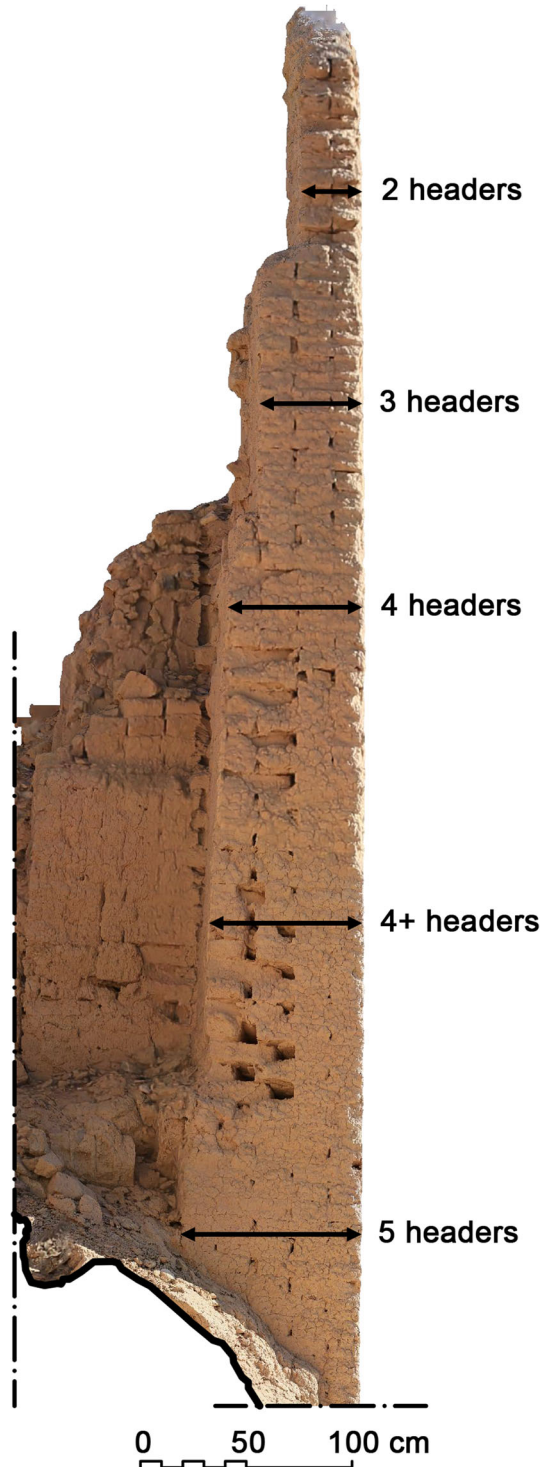

(exposed) portion of the wall is 5 headers wide; then the thickness is reduced to a bit more than 4 headers thanks to the presence of voids in the masonry; above this section, the voids disappear and the wall becomes 4 headers thick; then the wall continues with the standard thickness of 3 headers (one cubit); and finally the uppermost level is only 2 headers thick. The passage from 3 to 2 headers at this level is also visible in Fig. 7: after the impost of the upper vaults, the wall resumes as only 2 headers thick.

The internal dimensions of the accessible rooms show a high degree of correspondence with simple numbers of cubits: length and width of the rooms include values of 3, 3 + 1/2, 4, 4 + 1/2, 5, 5 + 1/2, and 6 cubits (Fig. 9). It is interesting that the measure 2 feet (found in some walls) can be also expressed as 1 + 1/3 cubit (thus mirroring the presence of measures involving the fraction 1/2



Fig. 9 Plan of the ground level showing internal dimensions of the accessible rooms in Egyptian cubits

cubit in the rooms); the same measures can be expressed using palms instead, and correspond to the addition of either 2 or 3 palms to the whole cubit. In Fig. 10 we chose to express these measurements using palms as, in this way, they better reflect the use of mudbricks designed on the foot/palm system.

The niches were 1 cubit wide, whilst the doorways were either 8 or 9 palms wide (corresponding to 4 headers and to $4 + 1/2$ headers; the latter is odd as it does not appear to correspond to a modular break in the mudbrick texture of the wall).

The vertical distance between two consecutive floor levels is precisely 5 cubits, with the exception of the ground floor, where two ground lines can be detected: the deeper lies exactly one cubit below the other one (cf. Fig. 3).

Inside the vaulted rooms, the discrepancies between the real measurements and the theoretically precise dimensions correspond to maximum 5 cm; this may be due to several reasons. Mudbrick architecture is less regular than stone architecture, and



Fig. 10 Reconstruction of the geometrical scheme of the plan of the Fort, based on Egyptian cubits

the addition of plaster smooths surfaces and alignments, as well as edges and corners. Moreover, once the overall dimensions of the building and of the rooms had been established, there was probably no need to be obsessively precise in terms of measurements. The tendency to bring to the extreme the search for a mathematical rule makes sense up to a certain point, from where probably more practical and prosaic considerations took over (e.g. Coulton 1977, Rossi 2004, Cuomo 2016).

In this case, it is possible to reconstruct the overall geometrical scheme, shown in Fig. 10: the plan, at ground floor, outlines an area of 27×27 cubits, that extends for 3 more cubits to the south to create the two towers (thus reaching a total north-south length of 30 cubits). These 3 additional cubits can be clearly measured at the ground level of the western tower; as the building grows taller, the outer wall becomes thinner, and at the third level the internal space of the room was half a cubit wider in all directions (cf. Fig. 8). This might have happened also in the eastern tower: here the ground level is engulfed by sand and cannot be measured, but the internal width and depth of the upper level is the same as its counterpart in the western tower, thus suggesting that the ground floors might have been similarly designed (cf. the internal outline of the two towers in Fig. 5).

It is interesting to note that the protruding towers can also be expressed as the result of the intersection of the 27×27 square with two spaces, most probably 5 cubit long and 4 cubits wide at ground level (cf. Fig. 10). This is a first hint that the plan was not based on a single geometrical scheme; this issue will be addressed again below.

Concerning the entire building, we took its internal (and not the external) outline as a reference for two reasons: one is that we have precise measurements of two opposite corners of this geometrical figure, and the second is that the ancient builders might have started from this outline, rather than the outer one, as the outer wall was meant to be slightly sloping. The internal face of the outer wall did step back at every level, but rose vertically. The outer slope was calculated in combination with the internal reduction of the thickness of the wall since the beginning so that, at the uppermost level, they aligned themselves into a one-mudbrick (two headers) thick wall.

The thickness of the wall at the ground level, therefore, must have been carefully planned since the beginning; however, as the basement of the building is surrounded by a thick buttress added later all around it, the outer baseline of the wall cannot be measured, but can only be theoretically reconstructed by projecting the alignments derived from the 3D survey. From our calculations, it seems that the thickness of the wall at ground level could correspond to 2 cubits; two small protruding 'steps', detected in the plan along the two southernmost opposite vertical cuts in the masonry, might indicate that the external wall of the entire southern block of the Fort, including the two towers, might have been slightly thicker ($2 + 1/2$ cubits, or 2 cubits + 3 palms). It is unclear, however, if these small 'steps' correspond to the original design, or are just due to a movement of the outer wall, pushed towards the outside by the mass of debris that fill the interior of the building.

The east, north and west walls of the Fort were each built in three separate sections, divided by vertical joints probably meant to absorb the natural shrinkage of the mudbrick masonry (Rossi and Ikram 2018: Chapter III.1). Along the 27 cubit-

long north side, the two vertical cuts are located every 9 cubits, whereas on the two 30 cubit-long western and eastern sides (inclusive of towers), they are located every 10 cubits (cf. Fig. 10).

The interior of the building (or at least the visible part) does not seem to blindly follow the alignment suggested by the geometry of the external walls. The division into three parts is quite clear in the northern portion of the building, where the north-eastern rooms appear to be more or less nestled into the 9-cubit spacing. The other rooms, however, do not appear to follow a precise scheme: there is a vague alignment of some features on a 5 + 5 cubit spacing, but it is not at all binding.

The latest investigations carried out in the deepest accessible spaces of the Fort revealed alignments and additional features suggesting that the design of this building was more complex than it may seem at first sight. One example is the presence of a wooden log nested in the masonry in the corridor serving the rooms in the north-eastern corner, that intercepts the vault at a level higher than its natural impost, thus allowing more vertical space to the narrow corridor (Rossi, forthcoming). How many of these details were planned in advance and how many were instead the result of reasoning and evaluations carried out directly during the construction, remains to be seen.

Only future excavations might reveal further information on the design of the interior of this building, and will allow this metrological analysis to be extended and refined.

For the moment, we may conclude that the building was designed on the basis of two overlapping geometrical patterns, based on modules of 3 and 5 cubits. Their mutual relationship is unclear: future investigations might reveal the existing connection between them, or its absence; if this is the case, it means that the construction followed a general scheme, but that the dimensions of the various portions could be freely aligned to the geometrical scheme that, in each case, would better suit the desired results, in relation with the construction technique and the inherent geometry of the mudbricks.

Discussion

Undoubtedly, the use of the Egyptian cubit in a Late Roman fort in a Western Desert oasis offers a number of interesting clues. The north Kharga fortified settlements belonged to a large-scale strategy of control over the Western Desert, and worked in connection with the network of legionary fortresses scattered in the other western oases and along the Nile (Rossi 2013). The strategic plan underlying these building operations, and the resources employed to implement them must have been Roman, but the fact that the Egyptian unit of measurement was not Roman, but Egyptian, cannot be simply explained as a consequence of the use of local workmen.

The north Kharga forts and settlements were built by ingeniously combining a set of architectural solutions and elements, that might or might not appear in different combinations: the gates of the main buildings, for instance, are all identical; vertical joints dividing the walls into sectors appear in some of them; sharp corners alternate with round buttresses; narrow passages hidden in the thickness of the external walls

appear in some forts; and virtually all rooms were covered by the same type of parabolic vault (Rossi and Ikram 2018: Chapter III.1).

The choice of the unit of measurement, therefore, must have been made by those whom we would now identify as the ‘architects’, that is, those who worked first at the project, and then, possibly, at the construction. The question, at this point, concerns the identity of these ‘architects’: were they Egyptian? Were they Roman and did they choose Egyptian cubits to facilitate the building operations carried out by local workmen?

Only future investigations in the area, and hopefully the discovery of written sources, might clarify these points. In the meanwhile, it is interesting to note that the survey of the 4th century AD fortified settlements in northern Kharga did not yield any evidence that may be classified as ‘non-Egyptian’. Tombs, grave goods, human remains, ceramics, the scant written sources, all point to an Egyptian community. The few ceramic imports indicate that trade was active along the caravan routes that crossed the oasis, but this is not surprising (Rossi and Ikram 2018: Chapter III.9).

The presence of the Roman army in the area is attested by an ostrakon from Ain al-Lebekha indicating that the *annona militaris* was raised locally, and by two papyri: one mentions the *Ala Prima Abasgorum* (listed again in the *Notitia Dignitatum*) and the other a *cohors* captained by an officer called Diphilos; the latter includes the names of many soldiers, all typical of 4th century AD Egypt (Rossi and Ikram 2018: 451). As its name implies, the *ala* stationed in Kharga was originally made of *Abasgi*, a population stationed on the coast of the Black Sea; if, as the decades dividing this papyrus from the *Notitia Dignitatum* appear to suggest, this *ala* remained officially stationed in the oasis for a long time, it is likely that it blended into the local population and raised new soldiers locally (Bagnall 1993: 176–7; Alston 1995: 156–62). This means that, in the long run, the presence of the Roman army does not necessarily imply the constant presence of non-Egyptian soldiers, at least not in the lower ranks.

In conclusion, the Late Roman fortified settlements of northern Kharga were conceived and sponsored by the Romans, were built and inhabited by Egyptians, and surveilled by garrisons of the Roman army mainly made of Egyptian soldiers. The identity of their ‘architects’, that is, of those who designed them, remains for the moment unknown. Hopefully future investigations will uncover evidence able to fill this gap and cast further light on this complex strategic operations that focused on the Kharga Oasis in the 4th century AD.

Acknowledgements This article is the outcome of a research funded by the European Research Council Consolidator Grant 681673. We wish to thank, first of all, both our granting body and our home institution, the Politecnico di Milano. Thanks also to the two anonymous referees, who offered precious insights into the subject of this article.

Open Access This article is distributed under the terms of the Creative Commons Attribution 4.0 International License (<http://creativecommons.org/licenses/by/4.0/>), which permits unrestricted use, distribution, and reproduction in any medium, provided you give appropriate credit to the original author(s) and the source, provide a link to the Creative Commons license, and indicate if changes were made.

References

- Alston R. 1995. *Soldier and Society in Roman Egypt: A Social History*. London, Routledge.
- Bagnall R. S. 1993. *Egypt in Late Antiquity*. Princeton, Princeton University Press.
- Ball, J. 1900. *Kharga Oasis: Its Topography and Geology*. Egypt Geological Survey 1899, Report 2. Cairo, National Printing Department.
- Beadnell, H. J. L. 1909. *An Egyptian Oasis: An Account of the Oasis of Kharga in the Libyan Desert, with Special Reference to its History, Physical Geography and Water-supply*. London, Murray.
- Colin, F. (ed.) 2012. *Bahariya I. Le fort romain de Qaret el-Toub I*. Fouilles de l'Institut français d'archéologie orientale 62. Cairo, IFAO.
- Coulton J. J. 1977. *Greek Architects at Work: Problems of Structure and Design*. Ithaca, Cornell University Press.
- Cuomo, S. 2016. Tacit knowledge in Vitruvius, *Arethusa* 49, no. 2: 125-43.
- Duncan-Jones, R. P. 1980. Length-units in Roman Town Planning. The Pes Monetalis and the Pes Drusianus, *Britannia* 11: 127-33.
- Fassi, F., C. Rossi, A. Mandelli. 2015. Emergency survey of endangered or logistically complex archaeological sites. *The International Archives of Photogrammetry, Remote Sensing and Spatial Information Sciences* 2015, 40.5: 85-91.
- Fiorillo F. and C. Rossi 2017. Metric analysis and interpretation of the unit of measurement in the Late Roman fort of Umm al-Dabadib (Egypt), in *Proceedings of the IMEKO International Conference on Metrology for Archaeology and Cultural Heritage 2017*: 139-44. Best Paper Award.
- Grenfell, B. P and A. S. Hunt, 1904. *The Oxyrhynchus Papyri* IV. London: Egypt Exploration Fund.
- Hirsch, A. P. 2013. *Ancient Egyptian Cubits – Origin and Evolution*. PhD Dissertation. University of Toronto, unpublished.
- Ikram S. and C. Rossi. 2004. North Kharga Oasis Survey 2001-2002 Preliminary Report: Ain Gib and Qasr el-Sumayra. *Mitteilungen des Deutschen Archaologischen Instituts Abteilung Kairo* 60: 69-92.
- Ikram S. and C. Rossi. 2006. North Kharga Oasis Survey 2003 Preliminary Report: Umm al-Dabadib. *Mitteilungen des Deutschen Archaologischen Instituts Abteilung Kairo* 62: 279-306.
- Ikram, S. and C. Rossi 2007. North Kharga Oasis Survey 2004 Preliminary Report: Ain el-Tarakwa, Ain el-Dabashiya and Darb Ain Amur. *Mitteilungen des Deutschen Archaologischen Instituts Abteilung Kairo* 63: 167-84.
- Ikram, S. and N. Warner. 2012. A Palace for Pigeons: Restoring a Roman Dovecote in the Kharga Oasis. *Bulletin of the American Research Center in Egypt* 20: 1-6.
- Johnstone S. 2011. *A History of Trust in Ancient Greece*. Chicago and London, The University of Chicago Press.
- Perfetti, L., C. Polari, F. Fassi. 2017. Fisheye Photogrammetry: Tests and Methodologies for the Survey of Narrow Spaces, *ISPRS-International Archives of the Photogrammetry, Remote Sensing and Spatial Information Sciences* 2017: 573-80.
- Pommerening T. 2913. Weights and Measures, Pharaonic Egypt. In R. S. Bagnall, K. Brodersen, C. B. Champion, A. Erskine and S. R. Huebner (eds.), *The Encyclopedia of Ancient History*. Oxford, Blackwell: 7087-92.
- Rossi, C. 2000. Umm el-Dabadib, Roman Settlement in the Kharga Oasis: Description of the Visible Remains, with a Note on 'Ayn Amur. *Mitteilungen des Deutschen Archaologischen Instituts Abteilung Kairo* 56: 235-52.
- Rossi, C. 2004. *Architecture and Mathematics in Ancient Egypt*. Cambridge, Cambridge University Press.
- Rossi, C. 2010. Science and technology', in A. B. Lloyd (ed.), *The Blackwell Companion to Ancient Egypt*, vol. I, chapter 21. Oxford, Blackwell: 390-408.
- Rossi, C. 2013. Controlling the borders of the empire: the distribution of Late-Roman 'forts' in the Kharga oasis. In: R. Bagnall, P. Davoli, and C. Hope (eds.), *The Oasis Papers 6, Proceedings of the Sixth Conference of the Dakhla Oasis Project*, Dakhla Oasis Project Monograph 15. Oxford, Oxbow: 331-6.
- Rossi C. 2016. Italian Mission to Umm al-Dabadib, Season 2014 – Preliminary Report. *Mitteilungen des Deutschen Archaologischen Instituts Abteilung Kairo* 72: 153-72.
- Rossi C. forthcoming. Italian Mission to Umm al-Dabadib, Season 2015 – Preliminary Report. Submitted to *Mitteilungen des Deutschen Archaologischen Instituts Abteilung Kairo*.
- Rossi, C. and S. Ikram. 2002. Petroglyphs and Inscriptions along the Darb Ain Amur, Kharga Oasis. *Zeitschrift der Ägyptischen Sprache* 129: 142-51.

- Rossi, C. and S. Ikram. 2006. North Kharga Oasis Survey 2003 Preliminary Report: Umm El-Dabadib. *Mitteilungen des Deutschen Archäologischen Instituts Abteilung Kairo* 62: 279-306.
- Rossi, C. and S. Ikram. 2010. North Kharga Oasis Survey 2007: Preliminary Report, Ain Lebekha and Ain Amur. *Mitteilungen des Deutschen Archäologischen Instituts Abteilung Kairo* 66: 235-42.
- Rossi, C. and S. Ikram. 2013. Evidence of Desert Routes across Northern Kharga: Egypt's Western Desert. In F. Förster and H. Riemer (eds.), *Desert Road Archaeology in Ancient Egypt and Beyond*. Africa Praehistorica 27. Köln, Heinrich-Barth-Institut: 265-82.
- Rossi, C. and S. Ikram. 2018. *North Kharga Oasis Survey: Explorations in Egypt's Western Desert*, British Museum Publications on Egypt and Sudan 5. Leuven, Peeters.
- Rossi, C. and G. Magli, forthcoming. Wind, Sand and Water: the Orientation of the Late Roman Forts in the Kharga Oasis (Egyptian Western Desert), in G. Magli, E. Antonello, J. A. Belmonte, A. César González-García, *Archaeoastronomy in the Roman World*. Berlin, Springer.
- Rossi, C., A. Migliozzi, F. Fassi, A. Mandelli, G.B. Chirico, C. Achille, S. Mazzoleni. 2015. Archeologia, scienza e tecnologia: lo studio del sito tardo-Romano di Umm al-Dabadib (Oasi di Kharga, Egitto). *Proceedings of the seminar L.O.S.A.I. (Laboratori Open su Scienza, Arte e Innovazione) 2015*. Napoli, Artstudiopaparo: 221-8.
- Wilson Jones, M. 2000. Doric Measure and Architectural Design 1: The Evidence of the Relief from Salamis. *American Journal of Archaeology* 104, no. 1: 73-93.

Dr. Corinna Rossi Architect (BA from the Università di Napoli Federico II, 1994) and Egyptologist (M.Phil. and Ph.D. from Cambridge University, 2000), Associate Professor of Egyptology at the Politecnico di Milano since 2016, P.I. of the ERC-funded project LIFE (Living In a Fringe Environment) and Director of the Italian Archaeological Mission to Umm al-Dabadib, Kharga Oasis, Egypt's Western Desert. She started her research with an in-depth study of the relationship between architecture and mathematics in ancient Egypt, that culminated in the publication of several articles on major Egyptological journals and of the book *Architecture and Mathematics in Ancient Egypt*, CUP 2004. She became interested in Egypt's Western Desert in the late '90s, with a special focus on the Kharga Oasis, where she has been working continuously until today, producing regular reports on peer-reviewed journals and the book *North Kharga Oasis Survey: Explorations in Egypt's Western Desert*, BMPES 5, 2018 (with S. Ikram).

Dr. Fausta Fiorillo Research fellow at ABC Department for the LIFE project, her main research activities focus on advanced techniques reality-based 3D survey, 3D data post-processing and 3D modelling. Graduated in Civil Engineering at the University of Salerno, she continued her research at the Laboratory of Architectural Photogrammetry of the University of Valladolid (Spagna) and at the Fondazione Bruno Kessler. After a PhD in Architecture and Urban Phenomenology at the University of the Basilicata she worked as research fellow at Department of Civil Engineering of the University of Salerno. She took part in different research projects (PRIN, FARB) and was in charge of the laser scanner survey and post-fieldwork processing in the 'Grande Progetto Pompei' (2015).