

Every Graph Admits an Unambiguous Bold Drawing

János Pach*

EPFL, Lausanne and Rényi Institute, Budapest
pach@cims.nyu.edu

Abstract. Let r and w be a fixed positive numbers, $w < r$. In a *bold drawing* of a graph, every vertex is represented by a disk of radius r , and every edge by a narrow rectangle of width w . We solve a problem of van Kreveld [K09] by showing that every graph admits a bold drawing in which the region occupied by the union of the disks and rectangles representing the vertices and edges does not contain any disk of radius r other than the ones representing the vertices.

1 Introduction

In this note, we adopt a “realistic” view of graph drawing, proposed by Marc van Kreveld [K09]. Let G be a graph with vertices v_1, \dots, v_n , represented by points in the plane, and let the edges be drawn as possibly crossing straight-line segments. Now fix two positive numbers r and w , $w < 2r$, and replace each vertex by a disk of radius r centered at v_i , and each edge $v_i v_j$ by a rectangle such that its midsegment is $v_i v_j$ and its width, the length of its side perpendicular to $v_i v_j$, is w . We call the union D of these disks and rectangles a *bold drawing* of G . A bold drawing is said to be *unambiguous* if it satisfies the following two conditions.

1. No two disks representing vertices of G intersect.
2. The set D contains no disk of radius r other than the disks representing its vertices.

The first condition is equivalent to saying that $2r$ is smaller than the minimum distance between two points v_i and v_j . It follows from the second condition that a bold drawing of a graph which has at least one edge can be unambiguous only if $w < 2r$. It was shown in [K09] that if $w > r$, then the maximum degree of the vertices of all graphs that admit an unambiguous bold drawing is bounded from above by a constant depending only on w and r . On the other hand, van Kreveld proved that for $w < r$, any *star* consisting of a central vertex connected to an arbitrary number of other vertices admits an unambiguous bold drawing.

* Supported by NSF Grant CCF-08-30272, by NSA, by OTKA under EUROGIGA project GraDR 10-EuroGIGA-OP-003, and by Swiss National Science Foundation Grant 200021-125287/1.

He also raised the question whether there exists a fixed pair of values w, r with $w < r$ such that with these parameters every finite graph admits an unambiguous bold drawing. The aim of this note is to answer this question in the affirmative in the following strong sense.

Theorem 1. *Let w and r be any positive constants with $w < r$. Then, for every positive integer n , the complete graph K_n admits an unambiguous bold drawing, in which the vertices are represented by disks of radius r and the edges by rectangles of width w .*

In the next statement, we describe our construction in full detail.

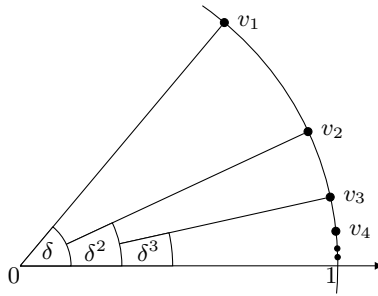

Fig. 1. Construction for Theorem 2

Theorem 2. *Let w and r be any positive constants with $w < r$. Let C be a circle of radius 1 around the origin, and let v_i ($1 \leq i \leq n$) denote the intersection point of C and the ray obtained from the positive x -axis by a counterclockwise rotation through angle δ^i , where $\delta = \min(\frac{1}{2}, 1 - \frac{w}{r})$.*

For every n , there exists a sufficiently small $\varepsilon = \varepsilon(n) > 0$ such that replacing each v_i by a disk of radius εr centered at v_i and each edge $v_i v_j$ by a rectangle of width εw with midsegment $v_i v_j$, the union of these disks and rectangles contains no disk of radius εr other than the ones representing the vertices.

Theorem 2 immediately implies Theorem 1. Indeed, if we choose $\varepsilon(n) > 0$ so small that in addition to the property in Theorem 2, it satisfies the inequality $2\varepsilon r < \min_{1 \leq i < j \leq n} |v_i v_j| = |v_{n-1} v_n|$, and we blow up the drawing described in Theorem 2 by a factor of $1/\varepsilon$, then we obtain a bold drawing of K_n that meets both requirements for unambiguity stated above.

In [K09], van Kreveld listed seven properties that a “good” bold drawing of a graph G must satisfy. These include the two conditions for unambiguous drawings stated above, so that every good bold drawing of G is also unambiguous. It is easy to see that if we choose the constant $\varepsilon(n)$ small enough, then our drawing of K_n will also meet the five additional properties formulated in [K09].

Before turning to the proof, we would like to argue that in some sense we are “forced” to consider constructions of the type described in Theorem 2. We say

that a set of points in the plane is in *general position* if no three of them are collinear. According to the Erdős-Szekeres theorem [ES35], for any integer K , every sufficiently large set of points in general position in the plane contains K elements that form the vertex set of a convex K -gon. This readily implies, that for any K there exists $N(K)$ such that any set of $N(K)$ points in general position has K elements that lie on a convex curve whose total turning angle is small. By rotating the coordinate axes if necessary, the coordinates of these points can be written as $(x_i, f(x_i))$, where $x_1 < x_2 < \dots < x_K$ and $f(x)$ is a smooth convex function whose derivative is bounded by a small constant. Let $\gamma = \frac{\sqrt{5}+1}{2} \approx 1.618$, the golden ratio. Color the triples (i, j, k) , $1 \leq i < j < k \leq K$, with *red*, *blue*, or *green*, according to whether $\frac{x_k - x_j}{x_j - x_i}$ is at most γ^{-1} , belongs to the interval (γ^{-1}, γ) , or is at least γ , respectively. According to Ramsey's theorem [R30, GRS90], for every $n \geq 4$ we can choose $K = K(n)$ so large that there is a sequence $1 \leq i_1 < i_2 < \dots < i_n \leq K$ with the property that all triples determined by its members are of the same color. It is easy to check that there exists no sequence of length 4 such that all of its triples are blue. Therefore, we can assume that all triples determined by the sequence $1 \leq i_1 < i_2 < \dots < i_n \leq K$ are red or all of them are green. In the first case the distances $x_{i+1} - x_i$ decrease, in the second one increase at least exponentially fast, as i grows ($1 \leq i \leq n$). Summarizing: for every $n \geq 4$, there is an integer N with the property that from any set of N points in general position in the plane we can select a sequence of length n which lies on an arc of a convex curve with small total turning angle and the distances between its consecutive elements decrease at least exponentially. (We can reverse the numbering of the elements, if necessary.) Suppose now that K_N admits an unambiguous bold drawing. Applying the last statement to the centers of the disks representing the vertices, we obtain an unambiguous bold subdrawing of a complete graph K_n such that the centers of the disks representing its vertices lie on a convex curve and the distances between them are fast decreasing. Our construction in Theorem 2 is motivated by this observation.

The proof of Theorem 2 is somewhat subtle. In Sect. 2, we introduce some definitions that simplify the presentation and we state two easy but useful lemmas that can be proved by direct computation. The heart of the proof lies in Lemma 5, stated and established in Sect. 3. After this preparation, the proof of Theorem 2 presented in Sect. 4 is rather straightforward.

Several graph drawing programs for straight-line drawing offer the option to draw the vertices and the edges bold (see, for example, NEATO [N04]). Some algorithmic aspects of bold drawing were addressed in [K09]. In particular, given a drawing of a graph G with possibly crossing straight-line edges, van Kreveld applied a line segment intersection algorithm [CE92], [CS89], [M88] to find the smallest w for which, if we draw the edges as closed rectangles of width w , we find three edges, not all incident to the same vertex, such that the corresponding rectangles have a point in common. Duncan, Efrat, Kobourov, and Wenk [DEKW06] presented an efficient algorithm to determine the largest w ,

for a given planar embedding of a graph G , such that G admits an equivalent drawing in which the edges are represented by nonoverlapping, not necessarily straight bold curves of width w .

2 Terminology and Two Preliminary Lemmas

In the rest of this note, w and r are fixed positive numbers with $w < r$. Throughout the next two sections, we also fix the parameter $\varepsilon > 0$, which will be varied only in Sect. 4, in the proof of Theorem 2.

First, we introduce some notation and terminology. Let v be a point of the plane, and let R_1, \dots, R_s be a set of infinite rays (half-lines) emanating from v , listed in clockwise order. Assume that all rays R_i point into the same half-plane bounded by a line passing through v . Replace v by a closed disk of radius εr centered at v , and replace each R_i by a closed one-way infinite half-strip of width εw with R_i as its mid-ray. The union of the disk and these half-strips is called a *palm* and is denoted by $P = P(v, R_1, \dots, R_s)$. The point v is said to be the *apex* of the palm, the half-strips are said to be its *fingers*, and the largest angle between the rays defining two (not necessarily consecutive) fingers is the *angle* of the palm.

If we go far enough from v , the fingers start to bifurcate. For any two consecutive fingers corresponding to the rays R_i and R_{i+1} , we define the *distance* from v at which they *bifurcate*, as the maximum radius of a disk centered at v with the property that its intersection with the complement of the union of the fingers (half-strips) is connected. Analogously, for any two (two-way infinite) *strips* S and S' such that their midlines cross at a point v , we define the distance from v at which they bifurcate as the maximum radius of a disk centered at v with the property that its intersection with the complement of $S \cup S'$ has at most *two* connected components.

The following two simple statements can be established by straightforward trigonometric calculations.

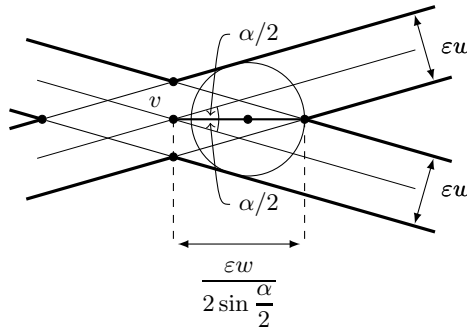

Fig. 2. For Lemma 3

Lemma 3. Let S and S' be two strips of width εw such that their midlines cross at a point v and the angle between them is $\alpha \leq \frac{\pi}{2}$. Then

1. $S \cup S'$ contains no disk of radius εw ;
2. S and S' bifurcate at distance $\frac{\varepsilon w}{2 \sin \frac{\alpha}{2}}$ from v ;
3. any two consecutive fingers of a palm such that the angle between the rays defining them is $\alpha \leq \pi/2$ bifurcate at distance $\frac{\varepsilon w}{2 \sin \frac{\alpha}{2}}$ from the apex.

Lemma 4. Let $P = P(v, R_1, \dots, R_s)$ be a palm as above, and assume that its angle is smaller than $2 \arcsin \frac{1}{4} < \frac{\pi}{6}$. Let $\bar{P} \supset P$ denote the union of the disk of radius εr centered at v and the convex hull of the union of the first and last fingers, corresponding to R_1 and R_s .

Then \bar{P} contains no disk of radius εr that intersects the disk of radius εr centered at its apex v . Hence, the same is true for P .

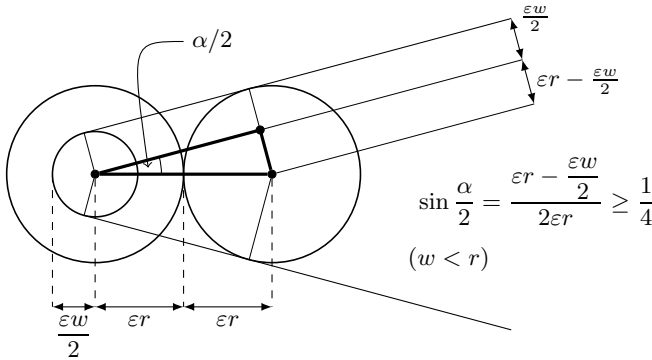

Fig. 3. For Lemma 4

3 The Main Lemma

As in the previous section, w, r , and ε are fixed positive constants, $w < r$. The main component of the proof of Theorem 2 is the following lemma, which guarantees that if the angles between the consecutive fingers of a palm P decrease sufficiently fast, then P cannot contain a disk of radius εr . The proof of this fact requires some detailed calculations, but heuristically it is clear that in this case only the first two fingers play an important role, and the situation is similar to the setting of Lemma 3, part 1.

Lemma 5. Let $\delta = \min(\frac{1}{2}, 1 - \frac{w}{r})$, and let $P = P(v, R_1, \dots, R_s)$ be a palm of angle $\alpha < \delta^{1/2}$. Let α_i denote the angle between R_i and R_{i+1} , and assume that for every i ($1 \leq i < s$) we have $\frac{\alpha_{i+1}}{\alpha_i} \leq \delta$.

Then P contains no disk of radius εr .

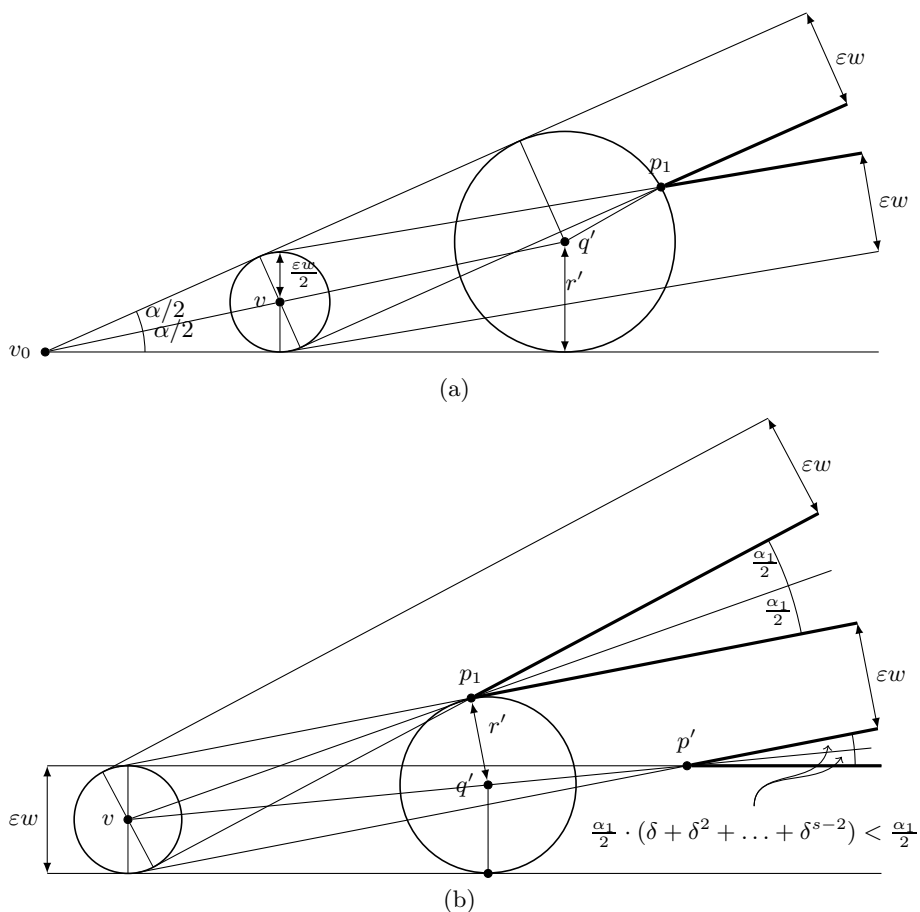

Fig. 4. For Lemma 5

Proof. If the fingers corresponding to R_i and R_{i+1} bifurcate at distance d_i from v , then they share a boundary point p_i with $|vp_i| = d_i$ ($1 \leq i < s$). These points are called *points of bifurcation*. It follows from the condition in Lemma 5 about the ratios α_{i+1}/α_i that $d_1 < d_2 < d_3 < \dots$ is a fast increasing sequence. If P has at most 2 fingers, then Lemma 5 is true by Lemma 3, part 1. Therefore, we can assume that s , the number of fingers, is at least 3 and that we have already proved the lemma for all palms with fewer than s fingers.

Suppose that $|vp_1| = d_1 = \min_{1 \leq i < s} d_i \leq \epsilon r$. Then P is the union of two palms $P(v, R_1)$ and $P(v, R_2, \dots, R_s)$, each having fewer than s fingers, so that any disk of radius ϵr other than the one centered at v must belong to one of them. Thus, in this case we are done, by induction. From now on assume that p_1 and hence all other points p_i lie outside of the disk of radius ϵr centered at v . Note that the part of the ray vp_i beyond the point p_i does not belong to P .

In fact, it lies in an infinite *open cone* C_i , symmetric about vp_i , which belongs to the complement of P . By rotating the coordinate system if necessary, we can assume without loss of generality that R_s is parallel to the positive x -axis, so that all other rays R_1, \dots, R_{s-1} point into the positive quadrant $x, y \geq 0$. Then it makes sense to talk about the *lower* and the *upper boundary* of a finger. The cone C_i is bounded by two half-lines: one belongs to the lower boundary of the finger corresponding to R_i and the other to the upper boundary of the finger corresponding to R_{i+1} .

Suppose for contradiction that P contains a disk D of radius at least εr , other than the disk of radius εr centered at v . It follows from Lemma 4 that D cannot intersect the disk of radius εr centered at v . We also know that D must have a point that belongs only to the first finger, but not to the second one, otherwise we can remove the first finger and obtain a contradiction using the induction hypothesis.

Let \overline{P} be the same as in Lemma 4, and let $P' \supset P$ denote the region obtained from \overline{P} by deleting all points that belong to the infinite cone C_1 with apex p_1 . Let D' be a disk of *maximum radius* in P' with the property that it has a point that belongs to the first finger of P , but not to the interior of the second one. Let q' and r' denote the center and the radius of D' . By our assumption, we have that $r' \geq \varepsilon r$, and it follows from Lemma 4 that D' does not intersect the disk of radius εr centered at v .

It is easy to verify that

1. p_1 lies on the boundary of D' ;
2. D' is tangent to the lower (horizontal) boundary half-line of \overline{P} ;
3. D' is tangent either to the upper boundary half-line of the second finger or to the upper boundary half-line of \overline{P} .

Indeed, it follows from the maximality of D' that D' is “fixed” by the boundary of P' . One point cannot fix a disk. The same is true for two points, one lying on the lower, one on the upper boundary half-line of \overline{P} . In other words, if D' is tangent to the lower and to the upper boundary half-lines of \overline{P} , by maximality, it must also touch the boundary of the cone C_i . Suppose first that D' is tangent to the upper boundary half-line of \overline{P} and to the upper boundary half-line of C_1 . If condition 1 is not satisfied, that is, D' touches a point of the upper boundary half-line of C_1 other than p_1 , then D' must lie entirely in the first finger, and its radius cannot exceed $\varepsilon w/2 < \varepsilon r$, which is impossible. Therefore, condition 1 is satisfied and, unless D' also satisfies condition 2, D' can be enlarged without violating the requirements.

Suppose next that D' is not tangent to the upper boundary half-line of \overline{P} . Then D' must be tangent to the lower boundary half-line of \overline{P} and to the lower boundary half-line of C_1 . Moreover, the point at which D' touches the lower boundary half-line of C_1 must be p_1 , otherwise D' cannot have a point that belongs to the first finger of P , but not to the interior of the second one. If D' has such a point *strictly* above the upper boundary of the second finger then it could be slightly enlarged without violating the conditions. Indeed, q' belongs to the locus of all points equidistant from p_1 and the (horizontal) supporting line

of the lower boundary half-line of \overline{P} , which is a parabola Π with a vertical axis of symmetry. If q' is on the left side of this parabola, then we can enlarge the radius of D' by moving q' along Π slightly to the left, if it is on the right side of Π , then by moving it slightly to the right. Therefore, we can conclude that D' must be tangent to the upper boundary of the second finger at point p_1 , and condition 3 holds.

Now we can easily complete the proof of Lemma 5.

If conditions 1, 2, and the first option in condition 3 hold, then consider the triangle vp_1q' . Using that $\delta \leq 1/2$, we obtain

$$\begin{aligned} \angle vp_1q' &= \frac{\pi}{2} - \frac{\alpha_1}{2} \leq \frac{\pi}{2} - \frac{\delta\alpha_1}{2(1-\delta)} \\ &< \frac{\pi}{2} - \frac{\alpha_1}{2}(\delta + \delta^2 + \dots + \delta^{s-2}) \\ &\leq \frac{\pi}{2} - \frac{\alpha_2 + \alpha_3 + \dots + \alpha_{s-1}}{2} = \angle vq'p_1 . \end{aligned}$$

This yields that $|vq'| < |vp_1|$. As was used above, the angle α_1 between R_1 and R_2 is larger than $\alpha_2 + \dots + \alpha_{s-1}$, the angle between R_2 and R_s . Therefore, the fingers corresponding to R_2 and R_s bifurcate at a point p' which is farther away from v than p_1 is. This implies that $|vq'| < |vp_1| < |vp'|$. The points v, q' , and p' are collinear, so that it follows from the last inequality that q' lies in the interior of the second finger. Since $r' = |q'p_1|$ is equal to the distance of q' from the upper boundary half-line of the second finger, we obtain that $r' < \varepsilon w < \varepsilon r$, which is a contradiction.

In the other case, when conditions 1, 2, and the second option in condition 3 hold, just like in the first case, we have $|vq'| < |vp_1|$. (In fact, it is easy to argue that the part of the parabola Π which lies below the line vp_1 and to the left of the line through p_1 perpendicular to R_s is entirely contained in the interior of the circle through p_1 centered at v . The point q' belongs to this arc.)

Let v_0 denote the intersection point of the supporting lines of the upper boundary ray of the first finger (that corresponds to R_1) and the lower boundary ray of the last finger (that corresponds to R_s). The points v_0, v , and q' are collinear. Using the notation $\alpha = \alpha_1 + \dots + \alpha_{s-1}$, we have

$$\begin{aligned} r' &= |v_0q'| \sin \frac{\alpha}{2} = (|v_0v| + |vq'|) \sin \frac{\alpha}{2} < (|v_0v| + |vp_1|) \sin \frac{\alpha}{2} \\ &\leq \left(\frac{\varepsilon w}{2 \sin \frac{\alpha}{2}} + \frac{\varepsilon w}{2 \sin \frac{\alpha_1}{2}} \right) \sin \frac{\alpha}{2} = \frac{\varepsilon w}{2} \left(1 + \frac{\sin \frac{\alpha}{2}}{\sin \frac{\alpha_1}{2}} \right) . \end{aligned}$$

Here we used Lemma 3, part 2 to estimate $|vp_1|$.

In view of the assumption on the angles between consecutive fingers, we have that

$$\alpha = \alpha_1 + \alpha_2 + \dots + \alpha_{s-1} = \alpha_1(1 + \delta + \dots + \delta^{s-2}) < \frac{\alpha_1}{1 - \delta} .$$

Hence, the above upper bound on r' can be rewritten as

$$r' < \frac{\varepsilon w}{2} \left(1 + \frac{\sin \frac{\alpha_1}{2(1-\delta)}}{\sin \frac{\alpha_1}{2}} \right) < \frac{\varepsilon w}{2} \left(1 + \frac{\frac{\alpha_1}{2(1-\delta)}}{\sin \frac{\alpha_1}{2}} \right) .$$

Using the Taylor series of the $\sin x$ function, it is easy to verify that, given any δ , $0 < \delta < 1$, the inequality $\sin \frac{\alpha_1}{2} > \frac{\alpha_1}{2(1+\delta)}$ holds for all $\alpha_1 \leq \delta^{1/2}$. By the assumptions in the lemma, this condition is satisfied, so that we have

$$r' < \frac{\varepsilon w}{2} \left(1 + \frac{1+\delta}{1-\delta} \right) = \frac{\varepsilon w}{1-\delta} .$$

By our choice of δ , we have $\delta \leq 1 - \frac{w}{r}$. That is,

$$r' < \frac{\varepsilon w}{1-\delta} \leq \varepsilon r ,$$

the desired contradiction. □

4 The Proof of Theorem 2

In the previous two sections, apart from n , w , and r , we also fixed the constant $\varepsilon > 0$. In the proof of Theorem 2 presented in this section, we keep n , w , and r fixed, but we will vary ε .

Let $S(\varepsilon)$ denote the union of the disks of radius εr representing the vertices v_i ($1 \leq i \leq n$) and the rectangles of width εw representing the edges $v_i v_j$ ($1 \leq i < j \leq n$).

For a given v_i , consider the rectangles representing the edges incident to v_i and extend them to one-way infinite half-strips pointing away from v_i . More precisely, for any $j \neq i$, let $R_{i,j}$ denote the ray $\overrightarrow{v_i v_j}$ emanating from v_i and pointing to the direction of v_j . Let $F_{i,j}(\varepsilon)$ be the half-strip of width εw , the mid-ray of which is $R_{i,j}$. The union of the disk of radius εr centered at v_i and the sets $F_{i,j}(\varepsilon)$ for all $j \neq i$ is denoted by $P_i(\varepsilon)$. Any two distinct half-strips $F_{i,j}(\varepsilon)$ and $F_{i,j'}(\varepsilon)$ bifurcate at a certain distance from v_i . Let $\varrho_i(\varepsilon)$ denote the maximum of these $\binom{n-1}{2}$ distances plus εr .

Let us fix a small $\varepsilon > 0$ such that the following three conditions are satisfied.

1. No three rectangles representing distinct edges, not all of which are incident to the same vertex, have a point in common.
2. Any rectangle representing an edge $v_j v_k$ is disjoint from any disk of radius $\varrho_i(\varepsilon)$ centered at v_i , for all $i \neq j, k$.
3. For every pair $i \neq j$, the disk of radius $\varrho_i(\varepsilon)$ centered at v_i is disjoint from the disk of radius $\varrho_j(\varepsilon)$ centered at v_j .

It follows from the second condition that no rectangle representing an edge $v_j v_k$ can intersect any disk representing a vertex v_i with $i \neq j, k$. The last condition implies that the disk of radius $\varrho_i(\varepsilon)$ centered at v_i cannot contain any disk of

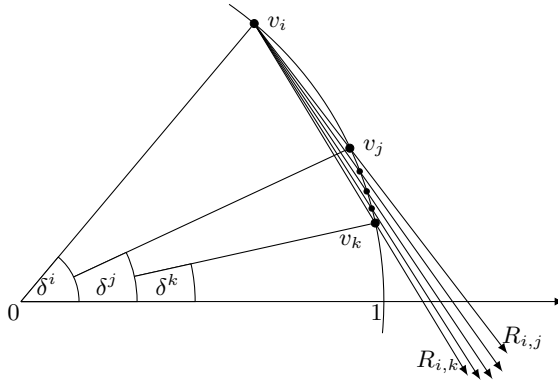

Fig. 5. For Proof of Theorem 2

radius εr representing a vertex v_j with $j \neq i$. If three edges share an interior point, then the first condition cannot be satisfied. However, it is easy to argue that in our case this cannot occur.

From now on ε will be fixed, so that in notation we can drop the parameter ε . In particular, instead of $S(\varepsilon)$, $\varrho_i(\varepsilon)$, and $P_i(\varepsilon)$, we will write S , ϱ_i , and P_i .

Suppose for contradiction that the set S contains a disk D of radius εr which is not one of the disks representing the vertices. Where can such a disk D lie? The only possibility is that for some i ($1 \leq i \leq n$), it lies in the part of S contained in the disk of radius ϱ_i centered at v_i . Otherwise, by the conditions listed above, D would be contained in the union of two strips of width w , contradicting part 1 of Lemma 3. Observe that the part of S contained in the disk of radius ϱ_i centered at v_i is exactly the same as the part of P_i contained in the disk of radius ϱ_i centered at v_i . Therefore, to finish the proof of Theorem 2, it is sufficient to show that no set P_i contains a disk of radius εr ($1 \leq i \leq n$).

To see this, notice that for every i $1 \leq i \leq n$, the set P_i can be written as the union of at most two palms of angle smaller than δ (see the beginning of Sect. 2). We have $P_1 = P(v_1, R_{1,2}, R_{1,3}, \dots, R_{1,n})$, $P_n = P(v_n, R_{n,1}, R_{n,2}, \dots, R_{n,n-1})$, and

$$P_i = P(v_i, R_{i,1}, R_{i,2}, \dots, R_{i,i-1}) \cup P(v_i, R_{i,i+1}, R_{i,i+2}, \dots, R_{i,n}) ,$$

for every i , $1 < i < j$. If $i \neq 1, n$, then the smallest angle between a finger of $P(v_i, R_{i,1}, R_{i,2}, \dots, R_{i,i-1})$ and a finger of $P(v_i, R_{i,i+1}, R_{i,i+2}, \dots, R_{i,n})$ is the angle between $R_{i,1}$ and $R_{i,n}$, which is equal to $\pi - \frac{\delta - \delta^n}{2} > \pi - \frac{\delta}{2}$. It follows from here that the fingers corresponding to $R_{i,1}$ and $R_{i,n}$ bifurcate within the disk of radius εr centered at v_i . This, in turn, implies that any disk D of radius εr which lies in P_i and is different from the disk representing v_i is entirely contained in one of the two palms comprising P_i . Applying Lemma 5 to this palm, we obtain the desired contradiction. The only thing that remains to be checked is that the conditions of the lemma about the angles α and α_i are satisfied.

The maximum angle of the palms of the form $P(v_i, R_{i,i+1}, R_{i,i+2}, \dots, R_{i,n})$ and $P(v_i, R_{i,1}, R_{i,2}, \dots, R_{i,i-1})$, for $1 \leq i \leq n$, is the angle of $P(v_n, R_{n,1}, R_{n,2}, \dots, R_{n,n-1})$, which is equal to

$$\angle v_1 v_n v_{n-1} = \frac{\angle v_1 0 v_{n-1}}{2} = \frac{\delta - \delta^{n-1}}{2} < \frac{\delta}{2},$$

so that the condition on the angle of the palm is satisfied. (Here 0 denotes the origin, the center of the circle containing all points v_i .) As for the condition on the angles α_i , we have that the angle between two consecutive rays $R_{i,t}$ and $R_{i,t+1}$ is equal to

$$\frac{\angle v_t 0 v_{t+1}}{2} = \frac{\delta^t - \delta^{t+1}}{2} = \frac{1 - \delta}{2} \delta^t.$$

Analogously, the angle between $R_{i,t+1}$ and $R_{i,t+2}$ is equal to $\frac{1-\delta}{2} \delta^{t+1}$. Hence, all ratios $\frac{\alpha_s}{\alpha_{s+1}}$ are equal to δ , and the conditions of Lemma 5 are satisfied.

This completes the proof of Theorem 2. \square

Acknowledgement. The author is grateful to Mark van Kreveld for calling his attention to the problem addressed in this paper, and to Radoslav Fulek, Fabrizio Frati, and Deniz Sariöz for valuable discussions, and Deniz Sariöz also for coding the figures in TikZ.

References

- [BGR04] Barequet, G., Goodrich, M.T., Riley, C.: Drawing planar graphs with large vertices and thick edges. *J. Graph Algorithms Appl.* 8, 3–20 (2004)
- [CE92] Chazelle, B., Edelsbrunner, H.: An optimal algorithm for intersecting line segments in the plane. *J. ACM* 39, 1–54 (1992)
- [CS89] Clarkson, K.L., Shor, P.W.: Application of random sampling in computational geometry, II. *Discrete & Computational Geometry* 4, 387–421 (1989)
- [DEKW06] Duncan, C.A., Efrat, A., Kobourov, S.G., Wenk, C.: Drawing with fat edges. *Int. J. Found. Comput. Sci.* 17, 1143–1164 (2006)
- [ES35] Erdős, P., Szekeres, G.: A combinatorial problem in geometry. *Compositio Mathematica* 2, 463–470 (1935)
- [GRS90] Graham, R., Rothschild, B., Spencer, J.H.: *Ramsey Theory*. John Wiley and Sons, New York (1990)
- [K09] van Kreveld, M.: Bold graph drawings. In: *Proc. Canadian Conference on Computational Geometry, CCCG 2009* (2009), http://cccg.ca/proceedings/2009/cccg09_31.pdf; Also *Computational Geometry: Theory & Applications* (to appear)
- [M88] Mulmuley, K.: A fast planar partition algorithm, I. In: *Proc. 29th FOCS*, pp. 580–589 (1988)
- [N04] North, S.C.: *Drawing Graphs with Neato* (2004), <http://www.graphviz.org/Documentation/neatoguide.pdf>
- [R30] Ramsey, F.P.: On a problem of formal logic. *Proc. London Math. Soc. Series* 30(2), 264–286 (1930)